

Special Board of Education Meeting

Tuesday, February 27, 2024 12:00 PM

Gering Public Schools - Central Office
1519 10th St
Gering, NE 69341



Minutes

1. **GPS Board of Education Information**

Absent: John Maser, Tracy Wiese, **Present:** Brian Copsey, Josh Lacy, B.J. Peters, Greg Trautman. **Absent:** John Maser, Tracy Wiese, **Present:** Brian Copsey, Josh Lacy, B.J. Peters, Greg Trautman.

2. **Opening Procedures**

2.1. Call to Order

President, Brian Copsey, called this meeting to order at 12:00 p.m.

2.2. Roll Call

2.3. Open Meetings Act

3. **Reports and Discussions**

3.1. 2022-23 Audit Report by Stacy Rodriguez

Stacy Rodriguez presented the Board of Education with a recap of the 2022-23 school year audit.

3.2. 2024-2029 Strategic Plan Report by Dr. Nicole Regan

Dr. Nicole Regan- On July 24th 2023, the Board of Education and district leadership began the journey with JNW Consulting to begin the Stakeholder Discovery Work and vision casting the hopes and dreams for Gering Public Schools. After 37 hours of planning sessions, 540 family survey feedback, and 92 staff and student focus group feedback, a Unified Strategic Plan was created. Five areas of focus are Academic Excellence, Investing in Staff, Modernizing Infrastructure, Operational Excellence, and Inspired Community Engagement. In the next five years, we have a vision-driven process to highlight our academic excellence, innovation, and responsiveness to the evolving needs of the community and education landscape. Our next steps will be executing the plan.

At 12:50 pm, a motion to go into closed session in regard to the approval of the 2024-25 school year negotiations, along with Dr. Regan and Stacy Rodriguez, were made by BJ Peters and the 2nd by Greg Trautman.

At 1: 25 pm, BJ Peters made a motion to exit closed session, and a 2nd was made by Josh Lacy.

4. **Action Items**

- 4.1. Discuss, consider, and take action regarding the approval of the 2024-25 school year calendar.
- 4.2. Discuss, consider, and take action regarding the GEA 2024-2025 school year negotiations.
- 4.3. Discuss, consider, and take action regarding the approval of the 5 yr Strategic Plan.
- 4.4. Discuss, consider, and take action regarding the approval of the purchase of a new Audio Enhancement Camera.

5. **Adjourn**

This meeting was adjourned at 1:31 p.m.

JANUARY 2024



Gering Public Schools

Learners today. Leaders tomorrow.

STRATEGIC PLAN 2024-2029



JNW CONSULTING, LLC

EXECUTIVE SUMMARY

CONSULTANT'S REPORT

Phase I: Vision Crafting and Review (July-August 2023)

On July 24th, 2023, the Gering Public Schools Superintendent, Leadership Team, and Board of Education gathered to begin Phase One of a three-phase Strategic Planning Initiative, facilitated by Jamie Weingart of JNW Consulting. The purpose of GPS' initial planning session was to review their current mission, vision, and values, as well as to begin to shape a compelling vision for Gering Public Schools' future. The in-depth evaluation of the mission, vision, and values resulted in a collective decision to adapt the language of the vision, as well as the core values of GPS. The team was assigned committee work to critically examine and refine these items for better alignment with the District's evolving needs and aspirations.

The planning team reconvened for continued work on August 26th, beginning with an in-depth presentation of language options for a new set of GPS core values, as well as a new vision that could redefine the future focus of student outcomes at GPS. These items are noted below.

Gering Public Schools Vision, Mission, and Values for 2024 and Beyond:

Vision: Gering Public Schools is a community where all students feel valued, respected, and inspired to develop to their fullest potential.

Mission: Gering Public Schools exists to equip today's learners with the skills necessary to be tomorrow's leaders.

Values:

- Culture of Pride
- Growth and Opportunity
- Resource Management and Fiscal Responsibility
- Trust and Integrity
- Quality

Phase II: Discovery Work with Stakeholders (September-November, 2023)

GPS' second phase involved extensive discovery work with diverse stakeholder groups, including principals, assistant principals, certified and classified staff, community leaders, parents and students. Through focused engagement in various forms, including targeted focus groups and surveys, valuable insights were gathered to understand the unique perspectives and expectations of each group. This inclusive approach ensured that the strategic planning process incorporated the diverse voices that will contribute to the success of both students and staff at Gering Public Schools for the next three to five years.

EXECUTIVE SUMMARY (CONTINUED)

Phase III: Strategic Planning Retreat (1.5 Days, [December, 2023-January, 2024])

GPS' third phase involved extensive discovery work with diverse stakeholder groups, including principals, assistant principals, certified and classified staff, community leaders, parents, and students. Through focused engagement in various forms, including targeted focus groups and surveys, valuable insights were gathered to understand the unique perspectives and expectations of each group. This inclusive approach ensured that the strategic planning process incorporated the diverse voices that will contribute to the success of both students and staff at Gering Public Schools for the next three to five years.

Outcome: A Robust 5-Year Strategic Plan

From the strategic priorities identified in the retreat, a robust and forward-looking 5-year strategic plan emerged. An action plan, along with deadlines and responsible parties, have been created under the five following areas of focus:

1. Academic Excellence
2. Investing in Staff
3. Modernizing Infrastructure
4. Operational Excellence
5. Inspired Community Engagement

It is anticipated that over the next five years, GPS' five strategic priorities and 21 defining objectives identified from the planning team's work will result in a quantitative outcome of at least 27 measurable, outcome-driven success indicators within the Gering Public School District. With these in mind, this plan will serve as a roadmap for Gering Public Schools leadership, staff, and stakeholders.

We believe that this strategic plan will position Gering Public Schools to capitalize on long-standing strengths and assets, provide an exceptional educational experience for students, and navigate challenges of the future.

In summary, the three-phase strategy process undertaken by Gering Public Schools has successfully produced a vision-driven, stakeholder-informed, and data-driven 5-year strategic plan. This plan sets the foundation for continued excellence, innovation, and responsiveness to the evolving needs of the community and the educational landscape.



Jamie Weingart
Jamie Weingart
Principal Consultant
JNW Consulting

GERING PUBLIC SCHOOLS

MISSION STATEMENT

Gering Public Schools exists to equip today's learners with the skills necessary to be tomorrow's leaders.

VISION

Gering Public Schools is a community where all students feel valued, respected, and inspired to develop to their fullest potential.

CORE VALUES

Culture of Pride:

At GPS, we believe that the core of who we are is a culture based on strong relationships and family, driven by Bulldog pride; therefore, we must tell our story, be secure and confident in who we are, and hold one another to a high standard.

Growth and Opportunity

At GPS, we believe in creating growth opportunities for our students; therefore, we must provide teachers and students with the resources necessary to develop workforce and college readiness skills

Resource Management and Fiscal Responsibility

At GPS, we believe that we are trusted stewards of local, state, and federal resources; therefore, we must be accountable to our stakeholders to effectively manage these resources and invest in a brighter future for students.

Trust and Integrity

At GPS, we believe in fostering an environment of trust; therefore, we must be consistent in communication and decision-making, while actively engaging our stakeholders.

Quality

At GPS, we believe that our students deserve a high-quality learning experience; therefore, we must create a learning environment where all students can thrive.



2024-2029 STRATEGIC PRIORITIES

1. Academic Excellence
2. Investing in Staff
3. Modernizing Infrastructure
4. Operational Excellence
5. Inspired Community Engagement

PRIORITY STATEMENTS

1. Gering Public School District will invest in **safe and inviting facilities** for the purpose of fostering an optimal learning environment.
2. The Gering Public School District is committed to creating high quality learning opportunities for the purpose of **student success and achievement**.
3. Develop and uplift talented **staff**.
4. Gering Public School District commits to maximizing **fiscal resources** for the purpose of enhancing operational excellence.
5. Gering Public Schools will strengthen **community engagement** for the purpose of inspiring involvement and pride.

KEY DEFINITIONS

Strategic Plan

A Strategic Plan outlines the future direction of an organization. It identifies how an organization will allocate their resources to achieve a desired future state, while positioning itself to be competitive and sustainable.

Strategic Priority

Each Strategic Priority represents and details the organization's focused commitment in pursuing the organizational Mission, Vision, and Values. These priorities are conceptual targets that the organization must successfully hit in order for the plan to have served its purpose.

Measures of Success

Measures of Success, also known as Key Performance Indicators (KPIs), represent a quantifiable measure of performance over time for each strategic priority.

Defining Objective

Defining Objectives within this plan refers to the overarching goals through which each strategic priority will be addressed.

Action Items

Action Items within this plan refer to the specific steps for action required to execute on Defining Objectives. Defining Objectives will often consist of several action items related to specific, measurable, achievable results. Action items will also be tied to responsible parties, deadlines, and status updates.

Responsible Party

The Responsible Party within this Strategic Plan represents the person/organizational role responsible for the execution of each Action Item. In partnership with the Superintendent, the Responsible Party has the authority to add tactics that will support the action plan, as well as to select additional team members to execute on each item.

HIGHLIGHTS OF GERING'S STRATEGIC PROCESS

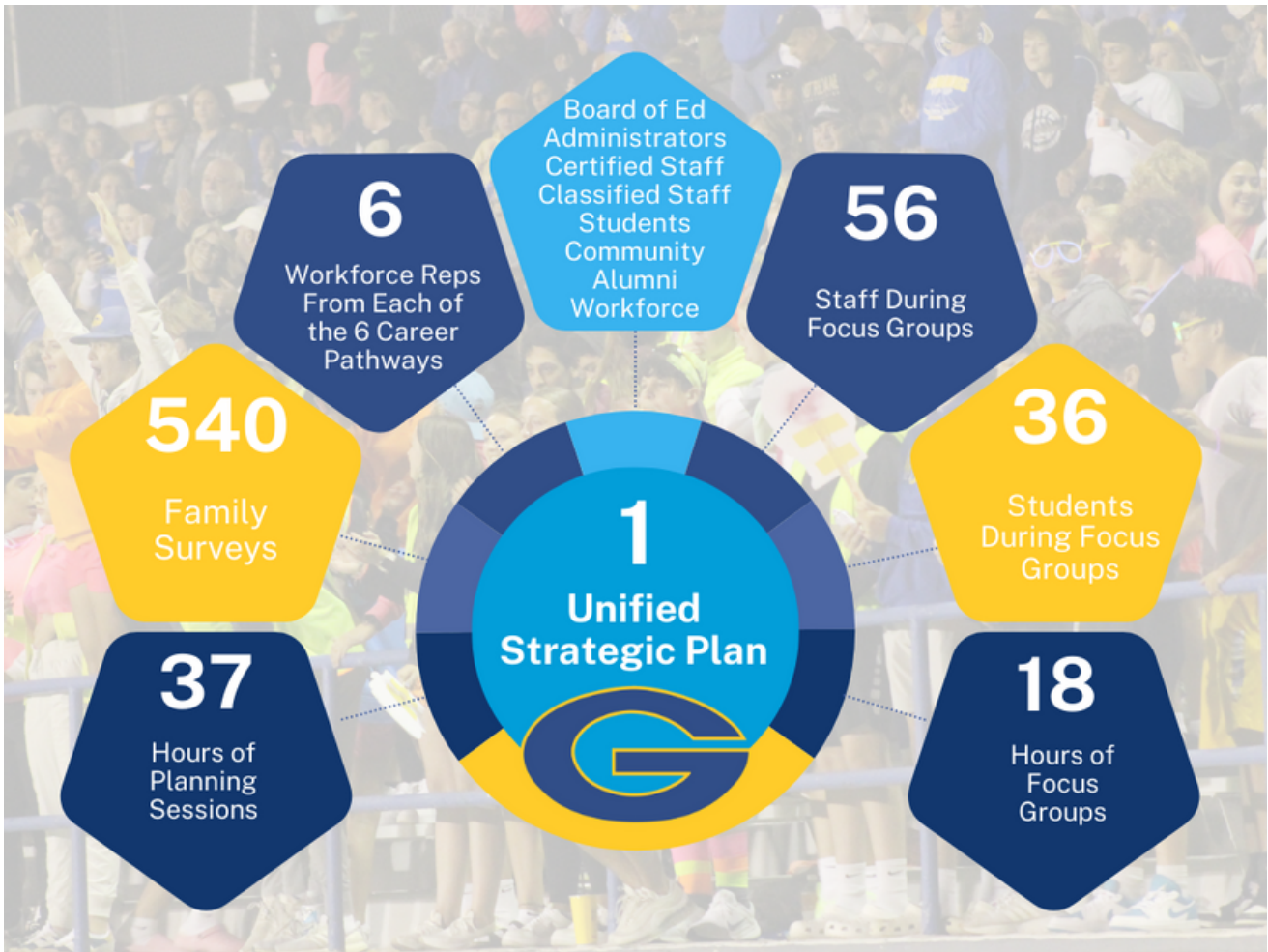

STRATEGIC PRIORITY #1

ACADEMIC EXCELLENCE

The Gering Public School District is committed to creating high quality learning opportunities for the purpose of **student success and achievement.**

MEASURES OF SUCCESS:

- Academic growth and proficiency increase
- Equitable opportunities - cradle to graduation cap
- Development of additional career pathway opportunities
- Social Emotional programming offered in all buildings
- Increase in activity participation

DEFINING OBJECTIVE	ACTION ITEMS
1. High-Quality Instruction: Focus on Consistent Implementation of High-Quality Instruction and Programming to Improve Student Outcomes.	A. Use data to measure and communicate student achievement and success <ol style="list-style-type: none"> 1. Teacher clarity 2. PLC (Continue, Review, and Refine) 3. Annual Report
	B. Invest in Behavioral Supports and Interventions <ol style="list-style-type: none"> 1. Review and Refine Existing Practices in Each Building 2. Through Data, Evaluate Effectiveness of Current Behavior Models 3. Continue PBIS initiatives
	C. Continue efforts to recognize and celebrate student achievement
	D. Accelerate student growth and achievement through technology education (i.e. Digital Citizenship, STEM, etc.)
2. Eliminate Opportunity Gaps	A. Address needs of student groups (EL, Special Ed, Etc.) <ol style="list-style-type: none"> 1. Define support needs 2. Create a plan to explore resource possibilities
	B. Align early childhood programming practices across the district
	C. Explore and Evaluate Curriculum Needs for Early Childhood
	D. Explore and Evaluate Transitional Kindergarten Options
3. College and Career Readiness: Champion Multiple Pathways for College and Career Readiness for All Students.	A. Continue to Evaluate and Grow Career Pathways
	B. Continue to Engage in Dual-Credit Partnerships and Opportunities <ol style="list-style-type: none"> 1. Define and Refine Institutional Processes and Partnerships
4. Cultivate and Model Strong Social-Emotional Skills	A. Create intentional strategies for bringing SEL resources and behavioral interventions, and wellbeing tools to students in all buildings. (i.e. Circle Groups, Peer Connections, Character Strong, Behaviors, Bullying, Emotional Safety)
	B. Within Building Goals, Create Strategies to Build and Improve Individual Relationships Between Staff and Students <ol style="list-style-type: none"> 1. Staff PD that will help with student support (i.e. Trauma-Informed)

STRATEGIC PRIORITY #1

ACADEMIC EXCELLENCE (CONT.)

The Gering Public School District is committed to creating high quality learning opportunities for the purpose of **student success and achievement.**

DEFINING OBJECTIVE	ACTION ITEMS
5. Enriching Experiences: Deliver Well-Rounded, Inspiring Educational and Comprehensive Experiences to Instill and Maintain Engagement in Learning.	A. Create building communication plan to educate students and families on club/org opportunities <ol style="list-style-type: none"> 1. Utilize multiple channels of communication 2. Develop an Opportunity Fair/Event
	B. Increase targeted, intentional outreach to connect and engage all students <ol style="list-style-type: none"> 1. Establish and communicate sponsor expectations 2. Improve access for students interested in extracurricular activities
	C. Educate families and students on opportunities available at key building transitions (Elementary to Middle School, Middle School to High School)

STRATEGIC PRIORITY #2

INVESTING IN STAFF

Develop and uplift talented staff.

MEASURES OF SUCCESS:

- Establish a “Grown Our Own” Career Ladder
- Implementation of classified staff professional network
- Existence of performance development tool and practices
- Differentiated, meaningful professional development opportunities
- Improvement in data measuring education profession pride
- Continued success in employee recruitment and retention

DEFINING OBJECTIVE	ACTION ITEMS
1. Effectively Recruit a Highly Qualified Workforce	<p>A. Elevate the perspective of teaching as a worthwhile and fulfilling career (more specific)</p> <ol style="list-style-type: none"> 1. Mentoring 2. Storytelling 3. Recruitment Fairs 4. Communication platforms 5. Career Pathway
	<p>B. Invest in marketing, recruitment, selection, of staff</p> <ol style="list-style-type: none"> 1. Follow recruitment and selection best practices leveraging our unique advantages <ol style="list-style-type: none"> a. Certified Staff b. Classified Staff c. Subs 2. Grow Your Own and Leverage Generational Pride by creating pathways for students to transition to district careers. 3. For recruitment and retention purposes, explore childcare as a possible employee benefit
2. Cultivate Staff Retention and Wellbeing Through Responsive and Affirming Practices.	<p>A. Convene a collaborative network of employees to develop and inform challenges for staff</p> <ol style="list-style-type: none"> 1. Continue Listening Opportunities (i.e. Superintendent Forums, Surveys, Peer Discussion Groups, 1:1s, etc.) 2. Create building-specific action-items for addressing needs.
	<p>B. Continually elevate, celebrate and recognize employee accomplishments and contributions</p> <ol style="list-style-type: none"> 1. Bulldogs Going Beyond 2. #TeacherFeature Series 3. Empower building level recognition strategies 4. Mentor of the Quarter
	<p>C. Develop Infrastructure to Elevate Classified Staff as an Essential Part of the Educational Team</p> <ol style="list-style-type: none"> 1. Establish PLCs 2. Develop Networking Cohorts 3. Create Relevant Training 4. Continue Onboarding

STRATEGIC PRIORITY #2

INVESTING IN STAFF (CONT.)

Develop and uplift talented staff.

DEFINING OBJECTIVE	ACTION ITEMS
2. Cultivate Staff Retention and Wellbeing Through Responsive and Affirming Practices (<i>cont.</i>)	D. Create Opportunities to Support Positive Peer Collaboration and Relationship-Building <ol style="list-style-type: none"> 1. Continue Teacher-Mentor Programs 2. Enhance Onboarding Program 3. Support building specific efforts and initiatives
	E. Promote career growth and tools to assist employees in planning and achieving their goals. <ol style="list-style-type: none"> 1. Explore and Develop career ladder opportunities
3. Invest in Relevant Professional Training and Development	A. Develop differentiated professional development plans for staff based on analysis of student need, staff interest and experience.
	B. Support and build capacity of all campus staff to implement welcoming trauma-informed practices. <ol style="list-style-type: none"> 1. Utilize Trauma Informed Team and tools to provide PD
	C. Build capacity of employees to promote individual wellness strategies. <ol style="list-style-type: none"> 1. Evaluate bringing in Burned-In Teacher Training 2. Continue to Communicate EAP Options 3. Invest in Crucial Conversations Training 4. Continue to evaluate other wellness tools and opportunities
4. Communicate and Maintain Consistent High Performance Standards	A. Foster a district wide culture of shared responsibility for student success. <ol style="list-style-type: none"> 1. Communicate the “why” behind goals, initiatives and district changes
	B. Strengthen the implementation of performance evaluation systems for teachers and administrators rooted in instruction frameworks that outline best-practices for teaching. <ol style="list-style-type: none"> 1. Launch online performance management tool 2. Update administrator evaluation tool

STRATEGIC PRIORITY #3

MODERNIZING INFRASTRUCTURE

Gering Public School District will invest in **safe and inviting facilities** for the purpose of fostering an optimal learning environment.

MEASURES OF SUCCESS:

- Gering Middle School Facility Improvement
- Prioritize preventative maintenance measures in all schools
- Enhanced safety-specific related infrastructure
- Continued positive data related to perception of school safety
- Progress made on facilities master plan
- Technology resources adequately aligned with current instructional practices

DEFINING OBJECTIVE	ACTION ITEMS
1. Maintain Preventative Maintenance Plan	A. Continue to identify our facilities' needs and prioritize improvements
2. Leverage Resources to Act on Facilities Master Plan and Improvements	A. Create a building-specific improvement plan and timeline for Gering Middle School
	B. Create a communication plan to effectively outline the need for facility improvements
	C. Address high-priority building and facility improvement needs (i.e. Track.)
3. Invest in Safety and Security Infrastructure	A. Create Infrastructure Inventory and Action Plan 1. (i.e., Expand and Update Safety Hardware)
4. Utilize Innovative and Modern Technology Tools and Resources	A. Align with Technology Plan and Replacement Cycle
	B. Meet with Principals to Address Student and Staff Technology Needs

STRATEGIC PRIORITY #4

OPERATIONAL EXCELLENCE

Gering Public School District commits to maximizing **fiscal resources** for the purpose of enhancing operational excellence.

MEASURES OF SUCCESS:

- Existence of sound budgeting practices
- Long-term financial stability driven by data-based decision-making
- Increase in stakeholder trust
- Resources aligned to meet the needs of students

DEFINING OBJECTIVE	ACTION ITEMS
1. Data-Driven Decision-Making	A. Sustain Budget
	B. Utilize Trending Data, Legislation Changes, Financial Aid, and Enrollment Information to Create Annual Financial Forecasts
	C. Continue to adapt to cash flow fluctuations
	D. Prioritize efficient, student-focused spending
	E. Continue to look for ways to streamline efficiencies
2. Provide Transparency to Stakeholders	A. Increase communication with staff and community regarding budget and financials
	B. Educate/inform taxpayers on impact of policy and legislative changes
	C. Share/communicate positive efforts and results
3. Sustain Funding with an Eye on Growing and Diversifying Funding Opportunities	A. Communicate our vision, strategy, and needs
	B. Engage our community, the private sector, and grantors for financial support 1. GPS Boosters & Foundation
4. Continue to Evaluate Right-Sizing our District with a Priority of Maintaining Ideal Class Size	A. Review Existing and Upcoming Enrollment
	B. Evaluate Resources and Capacity 1. Staff 2. Facilities 3. Class Size
	C. Align Budget

STRATEGIC PRIORITY #5

INSPIRED COMMUNITY ENGAGEMENT

Gering Public Schools will strengthen **community engagement** for the purpose of inspiring involvement and pride.

MEASURES OF SUCCESS:

- Create multiple opportunities for stakeholders to engage and share perspectives
- Increase community involvement within school district
- Existence of a measure to define and grow Gering Bulldog Pride
- Engagement within at local, state and national communities
- Grow meaningful work-based learning opportunities
- Increase family partnership opportunities

DEFINING OBJECTIVE	ACTION ITEMS
1. Honoring Perspectives: Honor and Actively Seek the Perspectives of the Students, Staff, Families and Community We Serve.	A. Establish advisory councils with students, families, staff and community to inform action plans at the school and district levels.
	B. Ensure multiple methods of participation for accessing community events, Board of Education Meetings and opportunities to provide feedback.
	C. Collaborate with community partners and students to continue meaningful work-based learning and leadership opportunities to advance development and experiences. <ol style="list-style-type: none"> 1. Continue to Support Relevant Career Pathways and Curriculum informed by workforce needs
2. Elevate Community Pride for GPS	A. Define, communicate and celebrate our Gering difference and our ongoing progress <ol style="list-style-type: none"> 1. Alumni Events 2. Hiring 3. Enrollment 4. Community Activities 5. Annual Report
	B. Create more intentional “ambassadorship” opportunities for stakeholders <ol style="list-style-type: none"> 1. Student Ambassador 2. Foundation Partnership 3. “Highlight Reels” 4. Annual Report
	C. Celebrate models of success through storytelling <ol style="list-style-type: none"> 1. Alumni Spotlight 2. “Homecoming” 3. #TeacherFeature 4. Retiree Network 5. Media Days
	D. Increase communication platforms and channels while they're here

STRATEGIC PRIORITY #5

INSPIRED COMMUNITY ENGAGEMENT

(CONT.)

Gering Public Schools will strengthen **community engagement** for the purpose of inspiring involvement and pride.

DEFINING OBJECTIVE	ACTION ITEMS
3. Leading for Impact	A. Lead and leverage our role as an impactful, key member of local, state and national communities
	B. Build Alignment Between City and School District Strategies
	C. Convene regular discussions with elected officials and governmental agencies to strengthen relationships and understanding that may influence policy making
	D. Build relationships with local community-based organizations and educational partners <ol style="list-style-type: none"> 1. Develop Teacher fair 2. Maximize dual credit opportunities 3. Booster Clubs
	E. Participate in statewide network of schools districts to be better informed of policies and practices
4. Strengthen Relationships Between Families, Students and Their School	A. Develop resources and activities to promote regular school community events to engage family and staff
	B. Expand school reach to build on community assets and relationships (Meet families in their communities)
	C. Establish learning opportunities to equip families with skills, information and networking opportunities to support students academic and social-emotional success. <ol style="list-style-type: none"> 1. Circle of Security 2. Explore other options
	D. Through professional development for educators, strengthen relationship and communication home to families. <ol style="list-style-type: none"> 1. Opening session training 2. PLC 3. Teacher Workdays 4. Proactive and positive communication best practices

GPS STRATEGIC PLANNING COMMITTEE

- Brian Copsey, Board member
- Kory Knight, Director of Curriculum and Assessment
- Josh Lacy, Board member
- John Maser, Board member
- Lindsey Mashek, Board secretary
- Byron Olsen, Director of Student Services
- BJ Peters, Board member
- Nicole Regan, Superintendent
- Stacy Rodriguez, Director of Business/Finance
- Jennifer Sibal, Director of Community Engagement
- Greg Trautman, Board member
- Tracy Wiese, Board member

CONSULTANT OBSERVATIONS & RECOMMENDATIONS

In the spirit of reflection and shared perspective regarding the planning process and future long-term success of GPS, the following observations and recommendations are offered by JNW Consulting, LLC:

Observations:

GPS is advantaged by a highly engaged, cohesive, and passionate Administration and an engaged, supportive Board of Education whose focus is strongly aligned with the GPS vision. The GPS Board of education seems to encompass a high level of trust and regard for the experience and expertise of GPS leadership and staff, and was fully involved throughout the planning process. Furthermore, GPS' planning efforts were detailed and discerning, with every strategic decision painstakingly made with students identified as first priority and top of mind.

Notably, the Gering Public Schools District upholds a long-standing sense of school pride that is deeply embedded into its culture. GPS seems highly committed to cultivating a distinctive identity, rooted in authentically embracing its strengths, developing its students, maintaining a financially-stable future, and building a healthy and mutually-beneficial relationship with the families and community members. Overall, GPS is highly invested in maximizing the individual strengths, abilities, and accomplishments of the students, staff, families, and community partners.

COMMUNICATION PLANNING

“Our strategy is only as effective as our ability to articulate it.”

At the formal adoption of the Strategic Plan by the Board of Education, Administration should develop and execute an all-encompassing communication plan that will ensure timely and appropriate communication of the new five-year initiatives, strategic priorities, and action items. It will be vital that effective communication of this plan is offered to GPS leaders and staff, with opportunities for questions, dialogue, and feedback. Once the plan has been formally adopted by the Board and fully presented

to GPS staff, other stakeholders of GPS (i.e. parents, community members, the GPS Foundation and Booster club, etc.) may benefit from access to a high-level version of this plan.

As GPS moves into future years, all parties should be informed of the plan's progress at a level appropriate to their engagement with the District.

TIMELINES AND STATUS UPDATES

JNW Consulting recommends that each Defining Objective is assigned a designated individual role that will be responsible for the ultimate execution of related action items and tactics. It is then recommended that the Defining Objective lead work with additional team members to refine action items and establish realistic, achievable deadlines for tactics.

This may be executed by requesting that each responsible party lead submit their action and timeline recommendations to the GPS Administration and Board of Education by August, 2024. An expanded, deadline-driven version of the Strategic Plan should then be presented to the Board of Education for formal approval in Fall of 2024.

For additional support with communication planning and the creating of formal timelines, JNW Consulting would be happy to extend its partnership with Gering Public Schools.

After Board approval, committees may find benefit in monitoring their work on a quarterly basis, in conjunction with the school calendar. GPS may benefit from the purchase or creation of a strategy progress dashboard, and it may prove beneficial to utilize a version of following language as GPS measures progress on each action item.

Status	Description
Hold	No Action Being Taken During This Quarter
In Development	The Development of Action Items & Tactics are in Progress
Discover, Research, and Recommend	Discovery Work and Research are in Progress, Implementation Pending
Implementation	Action Items and Tactics are Being Implemented by Responsible Parties
Sustain and Monitor	Defining Objectives, Action Items, and Tactics are Executed. *This Phase May Require Additional Monitoring to Measure Success and Effectiveness
Complete	Defining Objectives, Action Items, and Tactics are Fully Operationalized within the School District
KPIs Met	The Action Plan is in Progress or Completion, and Measures of Success identified within the original Strategic Plan have been fully realized.

TIMELINES AND STATUS UPDATES (CONTINUED)

A Potential Revised Strategy Table or Dashboard May Look Similar to the Following:

Strategic Priority #1									
Measures of Success:									
	Action Item	Responsible Party Leader	Responsible Party Members	Deadline	Status 2023-2024	Status 2024-2025	Status 2025-2026	Status 2026-2027	Status 2027-2028
Defining Objective #1									
Defining Objective #2									

Upon the first anniversary of the Strategic Plan (Winter, 2025), JNW Consulting recommends that Administration, Board, and Relevant Strategy Partners/Leaders meet for a retreat-style session to review progress on the plan and make modifications as necessary to meet the evolving needs of the School District.

A suggested annual retreat outline is as follows:

1. Introductions and Check-Ins
2. Review of Mission, Vision, and Values
3. Review of Progress Made on Each Strategic Priority, Defining Objective, and Action Item (prepared in advance by Responsible Party Leaders)
4. Celebration of Successes
5. Identification of Opportunities to Modify, Revise, or Recalibrate Plan
6. Formal Decision-Making Regarding Modifications to Existing Plan
7. Formal Report Written as Addendum to original Plan, to be Presented to the Board of Education for Review and Approval.
8. Development and Execution of updated Constituent Communication Plan and/or annual report

Listed below are recommended next steps in the strategy process for Gering Public Schools.

Winter, 2024	<ul style="list-style-type: none"> • Board Approval with Formal Adoption of Strategic Plan
Spring	<ul style="list-style-type: none"> • Timelines Added • Creation of Communication Plan
End of Year Meetings, 2024	<ul style="list-style-type: none"> • Communication Plan Rollout; Formal Introduction of Strategic Plan to Leaders, Staff, and Students
Spring, 2024	<ul style="list-style-type: none"> • Adoption of Data-Tracking Dashboard • Formal Selection of and Delegation to Action Planning Committees • Begin Work on Strategic Objectives
Winter, 2024	<ul style="list-style-type: none"> • Annual Progress Review of Strategic Plan

FINAL THOUGHTS AND MESSAGE OF GRATITUDE

This report is presented with special gratitude for the GPS Administration and Board of Education in regard to their extensive involvement and engagement in the planning process.

Further appreciation is owed to the GPS Leaders, Staff, Students, Parents, and Community partners who volunteered their time to provide insights, perspectives, advice, and feedback that could lead to a successful future for all GPS constituents.

A special thanks is owed to Charles Lieske, Mediation West Executive Director, and Judy Amoo, Mediation West Community Mediation and Restorative Practices Specialist. Through their correlating community partnership project and longstanding partnership with Gering Public Schools, Judy and Charles provided instrumental support, resources, and research findings throughout the Strategy process.

As GPS moves further into their plan, it is with hope that all who will be affected by this plan feel a sense of clarity regarding Gering Public Schools' priorities and future steps, as well as a sense of hope and optimism for continued growth and success. Most importantly, through effective communication and impactful leadership, the Gering Public Schools Administration and Board hope that this plan inspires trust and faith that the decisions of the GPS District over the next five years will be made with students, families, educators, and the community overall top of mind.

We extend our best wishes to GPS as they continue the pursuit of a compelling vision, to become "...a community where all students feel valued, respected, and inspired to develop to their fullest potential."

Best Regards,
Jamie N. Weingart

This plan is a living document that provides strategic direction and guidance for Gering Public Schools. The Gering Public School Superintendent, Leadership, Board, staff and community are committed to successfully implementing these objectives in the pursuit of Gering Public Schools mission to “equip today's learners with the skills necessary to be tomorrow's leaders.”



Jamie N. Weingart
JNW Consulting, LLC.

Let's explore what you do well so that you can do more of it.



NEW TEACHER ORIENTATION

STAFF DEVELOPMENT

HOLIDAY

EARLY RELEASE

Work/Comp Day

[] BEGIN/END NINE WEEKS

AUGUST 2024

S	M	T	W	TH	F	S
				1	2	3
4	5	6	7	8	9	10
11	12	13	14	15	16	17
18	19	20	21	22	23	24
25	26	27	28	29	30	31

Aug 5-7 New Teacher Orientation
 Aug 12-15 Staff Development
 Aug 16 Workday
 Aug 19 K-12 First Day of School
 1st Qtr Begins
 Aug 21 PreK First Day of School

Students: 10 Staff: 15

SEPTEMBER 2024

S	M	T	W	TH	F	S
1	2	3	4	5	6	7
8	9	10	11	12	13	14
15	16	17	18	19	20	21
22	23	24	25	26	27	28
29	30					

Sept 2 No School: Labor Day
 Sept 16 No School: Staff Develop.

Students: 19 Staff: 20

OCTOBER 2024

S	M	T	W	TH	F	S
		1	2	3	4	5
6	7	8	9	10	11	12
13	14	15	16	17	18	19
20	21	22	23	24	25	26
27	28	29	30	31		

Oct 16 Early Release @ 11:30am
Academic Focus 1/2 Workday
 Oct 17 No School: Staff Workday
 Oct 18 No School: Staff Develop.
 Oct 21-23 PT Conferences
 Oct 25 No School
Students & Staff

Students: 19.5 Staff: 23

NOVEMBER 2024

S	M	T	W	TH	F	S
					1	2
3	4	5	6	7	8	9
10	11	12	13	14	15	16
17	18	19	20	21	22	23
24	25	26	27	28	29	30

Nov 27-29 No School:
Thanksgiving Break

Students: 18 Staff: 18

DECEMBER 2024

S	M	T	W	TH	F	S
1	2	3	4	5	6	7
8	9	10	11	12	13	14
15	16	17	18	19	20	21
22	23	24	25	26	27	28
29	30	31				

Dec 20 End 2nd Qtr/Semester
 *Dec 23-31 No School: Holiday
 (*Continues into January)

1st Sem: 81.5 Days

Students: 15 Staff: 15

2024 • 2025
 CALENDAR

JANUARY 2025

S	M	T	W	TH	F	S
			1	2	3	4
5	6	7	8	9	10	11
12	13	14	15	16	17	18
19	20	21	22	23	24	25
26	27	28	29	30	31	

Jan 1-3 No School: Holiday
 Jan 6 No School: Staff Workday
 Jan 7 1st Qtr Begins

Students: 19 Staff: 20

FEBRUARY 2025

S	M	T	W	TH	F	S
						1
2	3	4	5	6	7	8
9	10	11	12	13	14	15
16	17	18	19	20	21	22
23	24	25	26	27	28	

Feb 14 No School: Staff Workday
 Feb 17 No School
 (ESU Mid-Winter Conf.)
 Feb 21 No School: Staff Develop.

Students: 17 Staff: 20

MARCH 2025

S	M	T	W	TH	F	S
						1
2	3	4	5	6	7	8
9	10	11	12	13	14	15
16	17	18	19	20	21	22
23	24	25	26	27	28	29
30	31					

Mar 12 Early Release @ 11:30am
Academic Focus 1/2 Workday
 Mar 13 End of 3rd Qtr
 Mar 14 No School: Staff Workday
 Mar 17-19 PT Conferences
PreK No School - Home Visits
 Mar 21 No School
Students & Staff

Students: 18.5 Staff: 21

APRIL 2025

S	M	T	W	TH	F	S
		1	2	3	4	5
6	7	8	9	10	11	12
13	14	15	16	17	18	19
20	21	22	23	24	25	26
27	28	29	30			

Apr 4 No School
1/2 Staff Dev. 1/2 Wrkdy
 Apr 18-21 No School: Spring Break

Students: 19 Staff: 20

MAY 2025

S	M	T	W	TH	F	S
				1	2	3
4	5	6	7	8	9	10
11	12	13	14	15	16	17
18	19	20	21	22	23	24
25	26	27	28	29	30	31

May 17 Graduation
 May 21 PreK Graduation
 May 22 Early Release @ 11:30am
 K-12 Last Day of School
1/2 Staff Workday
 May 23 Staff Workday

2nd Sem: 89 Days

Students: 15.5 Staff: 17





GEA Proposal February 19th, 2024

Article IV: Salaries

C. BASE SALARY

The base salary for the ~~2022-23~~ **2024-2025** school year shall be ~~\$38,150~~, and for the ~~2023-24~~ school year shall be ~~\$39,000~~ **\$39,500**. Each teacher covered by this agreement shall receive an additional flat salary or fringe benefit amount of \$10,000 for ~~2022-2024~~ **2024-2025** school years, subject to the terms of the Flat Dollar Salary and Fringe Benefit. The compensation will be prorated to the percentage of time worked. Part-time teachers with FTE status of 0.5 or greater shall receive a flat dollar salary amount based on FTE position.

D. FLAT DOLLAR SALARY AMOUNT

For all employees subject to this agreement through employment by the Gering Public School District **employed at any time prior to January 1, 2012**, the District shall pay such Employee a flat dollar salary amount of \$833.33 per month per full-time certificated employee as part of the salary package for the ~~2022-24~~ **2024-2025** school years, unless the employee elects to receive the Fringe Benefit outlined in the following section.

E. FRINGE BENEFIT

For all employees subject to this agreement through employment by the Gering Public School District **employed at any time after January 1, 2012**, the District shall pay such employees a Fringe Benefit amount of \$833.33 per month per full-time certificated employee as part of the salary package for ~~2022-24~~ **2024-2025** school years. An Employee hired at any time prior to or during the 2011-2012 school year may make a one-time irrevocable election to receive the Fringe Benefit.

Rationale: These changes are to reflect the tentative verbal agreement reached between the BOE and GEA at the previous negotiations meeting.

Article V: Fringe Benefits

All teachers with FTE status of 0.5 or greater shall have the right to exercise the option of participating in any of the fringe benefits offered by the District.

A. HEALTH INSURANCE

The Association will choose the insurance carrier and deductible for health and accident insurance.

For the ~~2022-24~~ **2024-2025** school years, the School District shall contract the Educators Health Alliance (EHA) **Blue Preferred \$1,050 Deductible / \$3,800 HSA Eligible Dual Choice** health insurance, or its equivalent successor deductible plan, and Option 2 PPO 100% A, 75% B, with 50% C dental coverage at the premium cost established annually by the EHA for such fiscal plan years.

All employees, whether receiving Flat Dollar salary amount or the Fringe Benefit, that chose to accept the EHA health insurance plan through Gering Public Schools will receive a health insurance benefit pursuant to this paragraph:

- **The District shall pay 50% of the annual single health premium,** with dental coverage, at the \$1,050 deductible premium level pursuant to the EHA schedule for the ~~2022-24~~ **2024-2025** school years if the individual teacher chooses that this fringe benefit is to be covered as part of the "125" IRS Cafeteria Plan. The remaining premium is to be covered as part of the "125" IRS Cafeteria Plan at the teacher's expense. If the teacher chooses to participate, he/she shall complete the necessary form for enrollment and authorization of payroll deductions. In addition, if the teacher desires to make any changes after the initial application, it will be their responsibility to amend the original enrollment.

JANUARY 2024



Gering Public Schools

Learners today. Leaders tomorrow.

STRATEGIC PLAN 2024-2029



JNW CONSULTING, LLC

EXECUTIVE SUMMARY

CONSULTANT'S REPORT

Phase I: Vision Crafting and Review (July-August 2023)

On July 24th, 2023, the Gering Public Schools Superintendent, Leadership Team, and Board of Education gathered to begin Phase One of a three-phase Strategic Planning Initiative, facilitated by Jamie Weingart of JNW Consulting. The purpose of GPS' initial planning session was to review their current mission, vision, and values, as well as to begin to shape a compelling vision for Gering Public Schools' future. The in-depth evaluation of the mission, vision, and values resulted in a collective decision to adapt the language of the vision, as well as the core values of GPS. The team was assigned committee work to critically examine and refine these items for better alignment with the District's evolving needs and aspirations.

The planning team reconvened for continued work on August 26th, beginning with an in-depth presentation of language options for a new set of GPS core values, as well as a new vision that could redefine the future focus of student outcomes at GPS. These items are noted below.

Gering Public Schools Vision, Mission, and Values for 2024 and Beyond:

Vision: Gering Public Schools is a community where all students feel valued, respected, and inspired to develop to their fullest potential.

Mission: Gering Public Schools exists to equip today's learners with the skills necessary to be tomorrow's leaders.

Values:

- Culture of Pride
- Growth and Opportunity
- Resource Management and Fiscal Responsibility
- Trust and Integrity
- Quality

Phase II: Discovery Work with Stakeholders (September-November, 2023)

GPS' second phase involved extensive discovery work with diverse stakeholder groups, including principals, assistant principals, certified and classified staff, community leaders, parents and students. Through focused engagement in various forms, including targeted focus groups and surveys, valuable insights were gathered to understand the unique perspectives and expectations of each group. This inclusive approach ensured that the strategic planning process incorporated the diverse voices that will contribute to the success of both students and staff at Gering Public Schools for the next three to five years.

EXECUTIVE SUMMARY (CONTINUED)

Phase III: Strategic Planning Retreat (1.5 Days, [December, 2023-January, 2024])

GPS' third phase involved extensive discovery work with diverse stakeholder groups, including principals, assistant principals, certified and classified staff, community leaders, parents, and students. Through focused engagement in various forms, including targeted focus groups and surveys, valuable insights were gathered to understand the unique perspectives and expectations of each group. This inclusive approach ensured that the strategic planning process incorporated the diverse voices that will contribute to the success of both students and staff at Gering Public Schools for the next three to five years.

Outcome: A Robust 5-Year Strategic Plan

From the strategic priorities identified in the retreat, a robust and forward-looking 5-year strategic plan emerged. An action plan, along with deadlines and responsible parties, have been created under the five following areas of focus:

1. Academic Excellence
2. Investing in Staff
3. Modernizing Infrastructure
4. Operational Excellence
5. Inspired Community Engagement

It is anticipated that over the next five years, GPS' five strategic priorities and 21 defining objectives identified from the planning team's work will result in a quantitative outcome of at least 27 measurable, outcome-driven success indicators within the Gering Public School District. With these in mind, this plan will serve as a roadmap for Gering Public Schools leadership, staff, and stakeholders.

We believe that this strategic plan will position Gering Public Schools to capitalize on long-standing strengths and assets, provide an exceptional educational experience for students, and navigate challenges of the future.

In summary, the three-phase strategy process undertaken by Gering Public Schools has successfully produced a vision-driven, stakeholder-informed, and data-driven 5-year strategic plan. This plan sets the foundation for continued excellence, innovation, and responsiveness to the evolving needs of the community and the educational landscape.



Jamie Weingart
Jamie Weingart
Principal Consultant
JNW Consulting

GERING PUBLIC SCHOOLS

MISSION STATEMENT

Gering Public Schools exists to equip today's learners with the skills necessary to be tomorrow's leaders.

VISION

Gering Public Schools is a community where all students feel valued, respected, and inspired to develop to their fullest potential.

CORE VALUES

Culture of Pride:

At GPS, we believe that the core of who we are is a culture based on strong relationships and family, driven by Bulldog pride; therefore, we must tell our story, be secure and confident in who we are, and hold one another to a high standard.

Growth and Opportunity

At GPS, we believe in creating growth opportunities for our students; therefore, we must provide teachers and students with the resources necessary to develop workforce and college readiness skills

Resource Management and Fiscal Responsibility

At GPS, we believe that we are trusted stewards of local, state, and federal resources; therefore, we must be accountable to our stakeholders to effectively manage these resources and invest in a brighter future for students.

Trust and Integrity

At GPS, we believe in fostering an environment of trust; therefore, we must be consistent in communication and decision-making, while actively engaging our stakeholders.

Quality

At GPS, we believe that our students deserve a high-quality learning experience; therefore, we must create a learning environment where all students can thrive.



2024-2029 STRATEGIC PRIORITIES

1. Academic Excellence
2. Investing in Staff
3. Modernizing Infrastructure
4. Operational Excellence
5. Inspired Community Engagement

PRIORITY STATEMENTS

1. Gering Public School District will invest in **safe and inviting facilities** for the purpose of fostering an optimal learning environment.
2. The Gering Public School District is committed to creating high quality learning opportunities for the purpose of **student success and achievement**.
3. Develop and uplift talented **staff**.
4. Gering Public School District commits to maximizing **fiscal resources** for the purpose of enhancing operational excellence.
5. Gering Public Schools will strengthen **community engagement** for the purpose of inspiring involvement and pride.

KEY DEFINITIONS

Strategic Plan

A Strategic Plan outlines the future direction of an organization. It identifies how an organization will allocate their resources to achieve a desired future state, while positioning itself to be competitive and sustainable.

Strategic Priority

Each Strategic Priority represents and details the organization's focused commitment in pursuing the organizational Mission, Vision, and Values. These priorities are conceptual targets that the organization must successfully hit in order for the plan to have served its purpose.

Measures of Success

Measures of Success, also known as Key Performance Indicators (KPIs), represent a quantifiable measure of performance over time for each strategic priority.

Defining Objective

Defining Objectives within this plan refers to the overarching goals through which each strategic priority will be addressed.

Action Items

Action Items within this plan refer to the specific steps for action required to execute on Defining Objectives. Defining Objectives will often consist of several action items related to specific, measurable, achievable results. Action items will also be tied to responsible parties, deadlines, and status updates.

Responsible Party

The Responsible Party within this Strategic Plan represents the person/organizational role responsible for the execution of each Action Item. In partnership with the Superintendent, the Responsible Party has the authority to add tactics that will support the action plan, as well as to select additional team members to execute on each item.

HIGHLIGHTS OF GERING'S STRATEGIC PROCESS

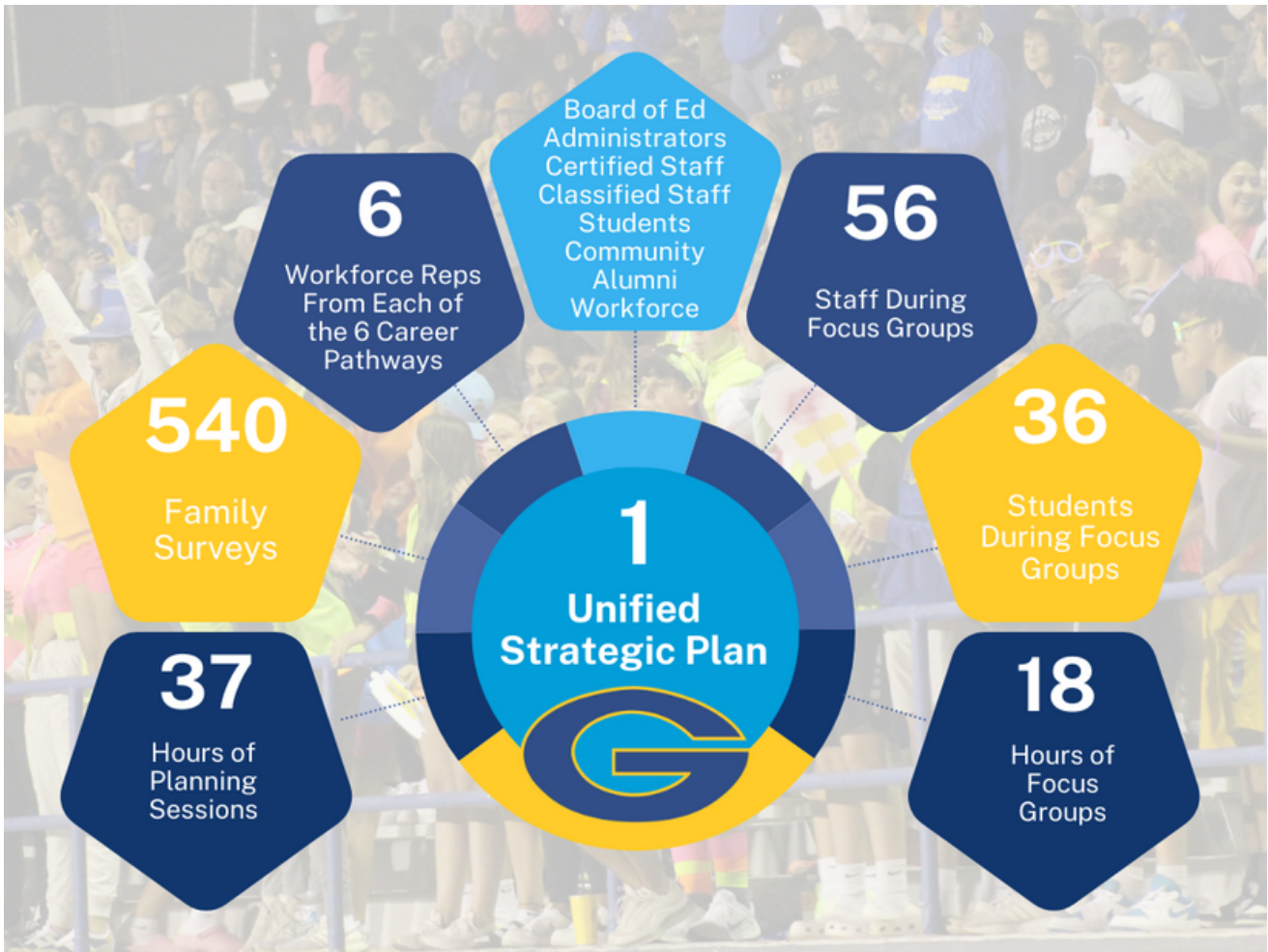

STRATEGIC PRIORITY #1

ACADEMIC EXCELLENCE

The Gering Public School District is committed to creating high quality learning opportunities for the purpose of **student success and achievement.**

MEASURES OF SUCCESS:

- Academic growth and proficiency increase
- Equitable opportunities - cradle to graduation cap
- Development of additional career pathway opportunities
- Social Emotional programming offered in all buildings
- Increase in activity participation

DEFINING OBJECTIVE	ACTION ITEMS
1. High-Quality Instruction: Focus on Consistent Implementation of High-Quality Instruction and Programming to Improve Student Outcomes.	A. Use data to measure and communicate student achievement and success <ol style="list-style-type: none"> 1. Teacher clarity 2. PLC (Continue, Review, and Refine) 3. Annual Report
	B. Invest in Behavioral Supports and Interventions <ol style="list-style-type: none"> 1. Review and Refine Existing Practices in Each Building 2. Through Data, Evaluate Effectiveness of Current Behavior Models 3. Continue PBIS initiatives
	C. Continue efforts to recognize and celebrate student achievement
	D. Accelerate student growth and achievement through technology education (i.e. Digital Citizenship, STEM, etc.)
2. Eliminate Opportunity Gaps	A. Address needs of student groups (EL, Special Ed, Etc.) <ol style="list-style-type: none"> 1. Define support needs 2. Create a plan to explore resource possibilities
	B. Align early childhood programming practices across the district
	C. Explore and Evaluate Curriculum Needs for Early Childhood
	D. Explore and Evaluate Transitional Kindergarten Options
3. College and Career Readiness: Champion Multiple Pathways for College and Career Readiness for All Students.	A. Continue to Evaluate and Grow Career Pathways
	B. Continue to Engage in Dual-Credit Partnerships and Opportunities <ol style="list-style-type: none"> 1. Define and Refine Institutional Processes and Partnerships
4. Cultivate and Model Strong Social-Emotional Skills	A. Create intentional strategies for bringing SEL resources and behavioral interventions, and wellbeing tools to students in all buildings. (i.e. Circle Groups, Peer Connections, Character Strong, Behaviors, Bullying, Emotional Safety)
	B. Within Building Goals, Create Strategies to Build and Improve Individual Relationships Between Staff and Students <ol style="list-style-type: none"> 1. Staff PD that will help with student support (i.e. Trauma-Informed)

STRATEGIC PRIORITY #1

ACADEMIC EXCELLENCE (CONT.)

The Gering Public School District is committed to creating high quality learning opportunities for the purpose of **student success and achievement.**

DEFINING OBJECTIVE	ACTION ITEMS
5. Enriching Experiences: Deliver Well-Rounded, Inspiring Educational and Comprehensive Experiences to Instill and Maintain Engagement in Learning.	A. Create building communication plan to educate students and families on club/org opportunities <ol style="list-style-type: none"> 1. Utilize multiple channels of communication 2. Develop an Opportunity Fair/Event
	B. Increase targeted, intentional outreach to connect and engage all students <ol style="list-style-type: none"> 1. Establish and communicate sponsor expectations 2. Improve access for students interested in extracurricular activities
	C. Educate families and students on opportunities available at key building transitions (Elementary to Middle School, Middle School to High School)

STRATEGIC PRIORITY #2

INVESTING IN STAFF

Develop and uplift talented staff.

MEASURES OF SUCCESS:

- Establish a “Grown Our Own” Career Ladder
- Implementation of classified staff professional network
- Existence of performance development tool and practices
- Differentiated, meaningful professional development opportunities
- Improvement in data measuring education profession pride
- Continued success in employee recruitment and retention

DEFINING OBJECTIVE	ACTION ITEMS
1. Effectively Recruit a Highly Qualified Workforce	<p>A. Elevate the perspective of teaching as a worthwhile and fulfilling career (more specific)</p> <ol style="list-style-type: none"> 1. Mentoring 2. Storytelling 3. Recruitment Fairs 4. Communication platforms 5. Career Pathway
	<p>B. Invest in marketing, recruitment, selection, of staff</p> <ol style="list-style-type: none"> 1. Follow recruitment and selection best practices leveraging our unique advantages <ol style="list-style-type: none"> a. Certified Staff b. Classified Staff c. Subs 2. Grow Your Own and Leverage Generational Pride by creating pathways for students to transition to district careers. 3. For recruitment and retention purposes, explore childcare as a possible employee benefit
2. Cultivate Staff Retention and Wellbeing Through Responsive and Affirming Practices.	<p>A. Convene a collaborative network of employees to develop and inform challenges for staff</p> <ol style="list-style-type: none"> 1. Continue Listening Opportunities (i.e. Superintendent Forums, Surveys, Peer Discussion Groups, 1:1s, etc.) 2. Create building-specific action-items for addressing needs.
	<p>B. Continually elevate, celebrate and recognize employee accomplishments and contributions</p> <ol style="list-style-type: none"> 1. Bulldogs Going Beyond 2. #TeacherFeature Series 3. Empower building level recognition strategies 4. Mentor of the Quarter
	<p>C. Develop Infrastructure to Elevate Classified Staff as an Essential Part of the Educational Team</p> <ol style="list-style-type: none"> 1. Establish PLCs 2. Develop Networking Cohorts 3. Create Relevant Training 4. Continue Onboarding

STRATEGIC PRIORITY #2

INVESTING IN STAFF (CONT.)

Develop and uplift talented staff.

DEFINING OBJECTIVE	ACTION ITEMS
2. Cultivate Staff Retention and Wellbeing Through Responsive and Affirming Practices (<i>cont.</i>)	D. Create Opportunities to Support Positive Peer Collaboration and Relationship-Building <ol style="list-style-type: none"> 1. Continue Teacher-Mentor Programs 2. Enhance Onboarding Program 3. Support building specific efforts and initiatives
	E. Promote career growth and tools to assist employees in planning and achieving their goals. <ol style="list-style-type: none"> 1. Explore and Develop career ladder opportunities
3. Invest in Relevant Professional Training and Development	A. Develop differentiated professional development plans for staff based on analysis of student need, staff interest and experience.
	B. Support and build capacity of all campus staff to implement welcoming trauma-informed practices. <ol style="list-style-type: none"> 1. Utilize Trauma Informed Team and tools to provide PD
	C. Build capacity of employees to promote individual wellness strategies. <ol style="list-style-type: none"> 1. Evaluate bringing in Burned-In Teacher Training 2. Continue to Communicate EAP Options 3. Invest in Crucial Conversations Training 4. Continue to evaluate other wellness tools and opportunities
4. Communicate and Maintain Consistent High Performance Standards	A. Foster a district wide culture of shared responsibility for student success. <ol style="list-style-type: none"> 1. Communicate the “why” behind goals, initiatives and district changes
	B. Strengthen the implementation of performance evaluation systems for teachers and administrators rooted in instruction frameworks that outline best-practices for teaching. <ol style="list-style-type: none"> 1. Launch online performance management tool 2. Update administrator evaluation tool

STRATEGIC PRIORITY #3

MODERNIZING INFRASTRUCTURE

Gering Public School District will invest in **safe and inviting facilities** for the purpose of fostering an optimal learning environment.

MEASURES OF SUCCESS:

- Gering Middle School Facility Improvement
- Prioritize preventative maintenance measures in all schools
- Enhanced safety-specific related infrastructure
- Continued positive data related to perception of school safety
- Progress made on facilities master plan
- Technology resources adequately aligned with current instructional practices

DEFINING OBJECTIVE	ACTION ITEMS
1. Maintain Preventative Maintenance Plan	A. Continue to identify our facilities' needs and prioritize improvements
2. Leverage Resources to Act on Facilities Master Plan and Improvements	A. Create a building-specific improvement plan and timeline for Gering Middle School
	B. Create a communication plan to effectively outline the need for facility improvements
	C. Address high-priority building and facility improvement needs (i.e. Track.)
3. Invest in Safety and Security Infrastructure	A. Create Infrastructure Inventory and Action Plan 1. (i.e., Expand and Update Safety Hardware)
4. Utilize Innovative and Modern Technology Tools and Resources	A. Align with Technology Plan and Replacement Cycle
	B. Meet with Principals to Address Student and Staff Technology Needs

STRATEGIC PRIORITY #4

OPERATIONAL EXCELLENCE

Gering Public School District commits to maximizing **fiscal resources** for the purpose of enhancing operational excellence.

MEASURES OF SUCCESS:

- Existence of sound budgeting practices
- Long-term financial stability driven by data-based decision-making
- Increase in stakeholder trust
- Resources aligned to meet the needs of students

DEFINING OBJECTIVE	ACTION ITEMS
1. Data-Driven Decision-Making	A. Sustain Budget
	B. Utilize Trending Data, Legislation Changes, Financial Aid, and Enrollment Information to Create Annual Financial Forecasts
	C. Continue to adapt to cash flow fluctuations
	D. Prioritize efficient, student-focused spending
	E. Continue to look for ways to streamline efficiencies
2. Provide Transparency to Stakeholders	A. Increase communication with staff and community regarding budget and financials
	B. Educate/inform taxpayers on impact of policy and legislative changes
	C. Share/communicate positive efforts and results
3. Sustain Funding with an Eye on Growing and Diversifying Funding Opportunities	A. Communicate our vision, strategy, and needs
	B. Engage our community, the private sector, and grantors for financial support 1. GPS Boosters & Foundation
4. Continue to Evaluate Right-Sizing our District with a Priority of Maintaining Ideal Class Size	A. Review Existing and Upcoming Enrollment
	B. Evaluate Resources and Capacity 1. Staff 2. Facilities 3. Class Size
	C. Align Budget

STRATEGIC PRIORITY #5

INSPIRED COMMUNITY ENGAGEMENT

Gering Public Schools will strengthen **community engagement** for the purpose of inspiring involvement and pride.

MEASURES OF SUCCESS:

- Create multiple opportunities for stakeholders to engage and share perspectives
- Increase community involvement within school district
- Existence of a measure to define and grow Gering Bulldog Pride
- Engagement within at local, state and national communities
- Grow meaningful work-based learning opportunities
- Increase family partnership opportunities

DEFINING OBJECTIVE	ACTION ITEMS
1. Honoring Perspectives: Honor and Actively Seek the Perspectives of the Students, Staff, Families and Community We Serve.	A. Establish advisory councils with students, families, staff and community to inform action plans at the school and district levels.
	B. Ensure multiple methods of participation for accessing community events, Board of Education Meetings and opportunities to provide feedback.
	C. Collaborate with community partners and students to continue meaningful work-based learning and leadership opportunities to advance development and experiences. <ol style="list-style-type: none"> 1. Continue to Support Relevant Career Pathways and Curriculum informed by workforce needs
2. Elevate Community Pride for GPS	A. Define, communicate and celebrate our Gering difference and our ongoing progress <ol style="list-style-type: none"> 1. Alumni Events 2. Hiring 3. Enrollment 4. Community Activities 5. Annual Report
	B. Create more intentional “ambassadorship” opportunities for stakeholders <ol style="list-style-type: none"> 1. Student Ambassador 2. Foundation Partnership 3. “Highlight Reels” 4. Annual Report
	C. Celebrate models of success through storytelling <ol style="list-style-type: none"> 1. Alumni Spotlight 2. “Homecoming” 3. #TeacherFeature 4. Retiree Network 5. Media Days
	D. Increase communication platforms and channels while they're here

STRATEGIC PRIORITY #5

INSPIRED COMMUNITY ENGAGEMENT

(CONT.)

Gering Public Schools will strengthen **community engagement** for the purpose of inspiring involvement and pride.

DEFINING OBJECTIVE	ACTION ITEMS
3. Leading for Impact	A. Lead and leverage our role as an impactful, key member of local, state and national communities
	B. Build Alignment Between City and School District Strategies
	C. Convene regular discussions with elected officials and governmental agencies to strengthen relationships and understanding that may influence policy making
	D. Build relationships with local community-based organizations and educational partners <ol style="list-style-type: none"> 1. Develop Teacher fair 2. Maximize dual credit opportunities 3. Booster Clubs
	E. Participate in statewide network of schools districts to be better informed of policies and practices
4. Strengthen Relationships Between Families, Students and Their School	A. Develop resources and activities to promote regular school community events to engage family and staff
	B. Expand school reach to build on community assets and relationships (Meet families in their communities)
	C. Establish learning opportunities to equip families with skills, information and networking opportunities to support students academic and social-emotional success. <ol style="list-style-type: none"> 1. Circle of Security 2. Explore other options
	D. Through professional development for educators, strengthen relationship and communication home to families. <ol style="list-style-type: none"> 1. Opening session training 2. PLC 3. Teacher Workdays 4. Proactive and positive communication best practices

GPS STRATEGIC PLANNING COMMITTEE

- Brian Copsey, Board member
- Kory Knight, Director of Curriculum and Assessment
- Josh Lacy, Board member
- John Maser, Board member
- Lindsey Mashek, Board secretary
- Byron Olsen, Director of Student Services
- BJ Peters, Board member
- Nicole Regan, Superintendent
- Stacy Rodriguez, Director of Business/Finance
- Jennifer Sibal, Director of Community Engagement
- Greg Trautman, Board member
- Tracy Wiese, Board member

CONSULTANT OBSERVATIONS & RECOMMENDATIONS

In the spirit of reflection and shared perspective regarding the planning process and future long-term success of GPS, the following observations and recommendations are offered by JNW Consulting, LLC:

Observations:

GPS is advantaged by a highly engaged, cohesive, and passionate Administration and an engaged, supportive Board of Education whose focus is strongly aligned with the GPS vision. The GPS Board of education seems to encompass a high level of trust and regard for the experience and expertise of GPS leadership and staff, and was fully involved throughout the planning process. Furthermore, GPS' planning efforts were detailed and discerning, with every strategic decision painstakingly made with students identified as first priority and top of mind.

Notably, the Gering Public Schools District upholds a long-standing sense of school pride that is deeply embedded into its culture. GPS seems highly committed to cultivating a distinctive identity, rooted in authentically embracing its strengths, developing its students, maintaining a financially-stable future, and building a healthy and mutually-beneficial relationship with the families and community members. Overall, GPS is highly invested in maximizing the individual strengths, abilities, and accomplishments of the students, staff, families, and community partners.

COMMUNICATION PLANNING

“Our strategy is only as effective as our ability to articulate it.”

At the formal adoption of the Strategic Plan by the Board of Education, Administration should develop and execute an all-encompassing communication plan that will ensure timely and appropriate communication of the new five-year initiatives, strategic priorities, and action items. It will be vital that effective communication of this plan is offered to GPS leaders and staff, with opportunities for questions, dialogue, and feedback. Once the plan has been formally adopted by the Board and fully presented

to GPS staff, other stakeholders of GPS (i.e. parents, community members, the GPS Foundation and Booster club, etc.) may benefit from access to a high-level version of this plan.

As GPS moves into future years, all parties should be informed of the plan's progress at a level appropriate to their engagement with the District.

TIMELINES AND STATUS UPDATES

JNW Consulting recommends that each Defining Objective is assigned a designated individual role that will be responsible for the ultimate execution of related action items and tactics. It is then recommended that the Defining Objective lead work with additional team members to refine action items and establish realistic, achievable deadlines for tactics.

This may be executed by requesting that each responsible party lead submit their action and timeline recommendations to the GPS Administration and Board of Education by August, 2024. An expanded, deadline-driven version of the Strategic Plan should then be presented to the Board of Education for formal approval in Fall of 2024.

For additional support with communication planning and the creating of formal timelines, JNW Consulting would be happy to extend its partnership with Gering Public Schools.

After Board approval, committees may find benefit in monitoring their work on a quarterly basis, in conjunction with the school calendar. GPS may benefit from the purchase or creation of a strategy progress dashboard, and it may prove beneficial to utilize a version of following language as GPS measures progress on each action item.

Status	Description
Hold	No Action Being Taken During This Quarter
In Development	The Development of Action Items & Tactics are in Progress
Discover, Research, and Recommend	Discovery Work and Research are in Progress, Implementation Pending
Implementation	Action Items and Tactics are Being Implemented by Responsible Parties
Sustain and Monitor	Defining Objectives, Action Items, and Tactics are Executed. *This Phase May Require Additional Monitoring to Measure Success and Effectiveness
Complete	Defining Objectives, Action Items, and Tactics are Fully Operationalized within the School District
KPIs Met	The Action Plan is in Progress or Completion, and Measures of Success identified within the original Strategic Plan have been fully realized.

TIMELINES AND STATUS UPDATES (CONTINUED)

A Potential Revised Strategy Table or Dashboard May Look Similar to the Following:

Strategic Priority #1									
Measures of Success:									
	Action Item	Responsible Party Leader	Responsible Party Members	Deadline	Status 2023-2024	Status 2024-2025	Status 2025-2026	Status 2026-2027	Status 2027-2028
Defining Objective #1									
Defining Objective #2									

Upon the first anniversary of the Strategic Plan (Winter, 2025), JNW Consulting recommends that Administration, Board, and Relevant Strategy Partners/Leaders meet for a retreat-style session to review progress on the plan and make modifications as necessary to meet the evolving needs of the School District.

A suggested annual retreat outline is as follows:

1. Introductions and Check-Ins
2. Review of Mission, Vision, and Values
3. Review of Progress Made on Each Strategic Priority, Defining Objective, and Action Item (prepared in advance by Responsible Party Leaders)
4. Celebration of Successes
5. Identification of Opportunities to Modify, Revise, or Recalibrate Plan
6. Formal Decision-Making Regarding Modifications to Existing Plan
7. Formal Report Written as Addendum to original Plan, to be Presented to the Board of Education for Review and Approval.
8. Development and Execution of updated Constituent Communication Plan and/or annual report

Listed below are recommended next steps in the strategy process for Gering Public Schools.

Winter, 2024	<ul style="list-style-type: none"> • Board Approval with Formal Adoption of Strategic Plan
Spring	<ul style="list-style-type: none"> • Timelines Added • Creation of Communication Plan
End of Year Meetings, 2024	<ul style="list-style-type: none"> • Communication Plan Rollout; Formal Introduction of Strategic Plan to Leaders, Staff, and Students
Spring, 2024	<ul style="list-style-type: none"> • Adoption of Data-Tracking Dashboard • Formal Selection of and Delegation to Action Planning Committees • Begin Work on Strategic Objectives
Winter, 2024	<ul style="list-style-type: none"> • Annual Progress Review of Strategic Plan

FINAL THOUGHTS AND MESSAGE OF GRATITUDE

This report is presented with special gratitude for the GPS Administration and Board of Education in regard to their extensive involvement and engagement in the planning process.

Further appreciation is owed to the GPS Leaders, Staff, Students, Parents, and Community partners who volunteered their time to provide insights, perspectives, advice, and feedback that could lead to a successful future for all GPS constituents.

A special thanks is owed to Charles Lieske, Mediation West Executive Director, and Judy Amoo, Mediation West Community Mediation and Restorative Practices Specialist. Through their correlating community partnership project and longstanding partnership with Gering Public Schools, Judy and Charles provided instrumental support, resources, and research findings throughout the Strategy process.

As GPS moves further into their plan, it is with hope that all who will be affected by this plan feel a sense of clarity regarding Gering Public Schools' priorities and future steps, as well as a sense of hope and optimism for continued growth and success. Most importantly, through effective communication and impactful leadership, the Gering Public Schools Administration and Board hope that this plan inspires trust and faith that the decisions of the GPS District over the next five years will be made with students, families, educators, and the community overall top of mind.

We extend our best wishes to GPS as they continue the pursuit of a compelling vision, to become "...a community where all students feel valued, respected, and inspired to develop to their fullest potential."

Best Regards,
Jamie N. Weingart

This plan is a living document that provides strategic direction and guidance for Gering Public Schools. The Gering Public School Superintendent, Leadership, Board, staff and community are committed to successfully implementing these objectives in the pursuit of Gering Public Schools mission to “equip today's learners with the skills necessary to be tomorrow's leaders.”



Jamie N. Weingart
JNW Consulting, LLC.

Let's explore what you do well so that you can do more of it.

Audio Enhancement Solutions Proposal



December 20, 2023

Proposal ID# 114570
SAP Quote# 58607

Prepared For Gering Public Schools



Dear Gering Public Schools,

I want to personally thank you for inviting us to submit a proposal to Gering Public Schools!

When my mother, Claudia Anderson, founded Audio Enhancement over 40 years ago, we never imagined the impact our services would have on education today. Through customer feedback, we have grown from offering classroom audio solutions to providing district-wide communication and safety technology. We have impacted over 4,000 districts, 39,000 schools, and over 1,200,000 classrooms across the world. We are excited for the opportunity to help you!

Our team focuses on hiring employees with a passion to make a difference in education. We look forward to developing a deeper partnership with Gering Public Schools through building friendship and trust during the ongoing stages of your project.

It is our pleasure to submit this proposal to Gering Public Schools. As with all proposals, revisions can be made at any time.

We look forward to your response and are available to answer any questions during the review process.

From all of us here at Audio Enhancement, thank you!

Sincerely yours,



A handwritten signature in blue ink that reads "Jeff Anderson".

Jeff Anderson
Audio Enhancement, CEO



Making a Difference in Education

For more than forty years, Audio Enhancement has served the schools throughout the United States, providing both classroom audio enhancement systems as well as integration services for classroom technology. Audio Enhancement is headquartered in Salt Lake City Utah and has facilities in Georgia and Florida.

Audio Enhancement was founded in 1978 by Claudia Anderson around the simple idea that “learning begins with hearing.” Having two hearing impaired children; the first Audio Enhancement systems were designed specifically for the hearing impaired. Early in our history, technological advancements made it possible to also provide whole classroom sound systems, benefiting all students. Audio Enhancement has been the innovator and leader in this field.

By 2004, it was clear that classroom audio enhancement systems were a key part of the overall technology landscape in the classroom. Based on our high level of support, outstanding customer service, and training that was provided for the audio systems, several school districts came to us and requested that we expand our product offerings. Based on these requests, we undertook an initiative to increase our capabilities in order to provide a complete integrated technology package for the classroom. These offerings include display devices, control, video/audio playback devices and interactive technologies. By utilizing the principles developed over thirty years of providing classroom audio systems to the schools, we were able to provide both technical integration, teacher in-servicing, training, and professional development to help the schools ensure the success of their technology goals.

Moving the company forward, in 2008, Audio Enhancement was incorporated: Jeff Anderson, President and CEO, Jennifer Crum, CFO, Jeremy Anderson, CAO and Justin Anderson, COO. Today, the Audio Enhancement product line improves student achievement, decreases teacher vocal fatigue and absenteeism, and creates positive student behavior. Audio Enhancement systems also increase focus and attention and supports classroom management.



The Anderson Family



Classroom Audio

A classroom Audio Enhancement system provides teachers with benefits seen in documented sound field system research with the consistency and clarity of the newest classroom technology—XD Audio. Teachers wear an XD Microphone with confidence of zero signal drop-outs. This delivers their voices to each student as clearly as if the teacher were sitting right next to them. With Classroom Audio, you can expect more time on task, fewer behavior issues, less teacher verbal repetition, and better content understanding. These provide an increase in actual instructional time, one thing every teacher can use more of. Clear and equitably distributed audio in the classroom contributes to the overall quality of instruction, targeting gaps in learning.

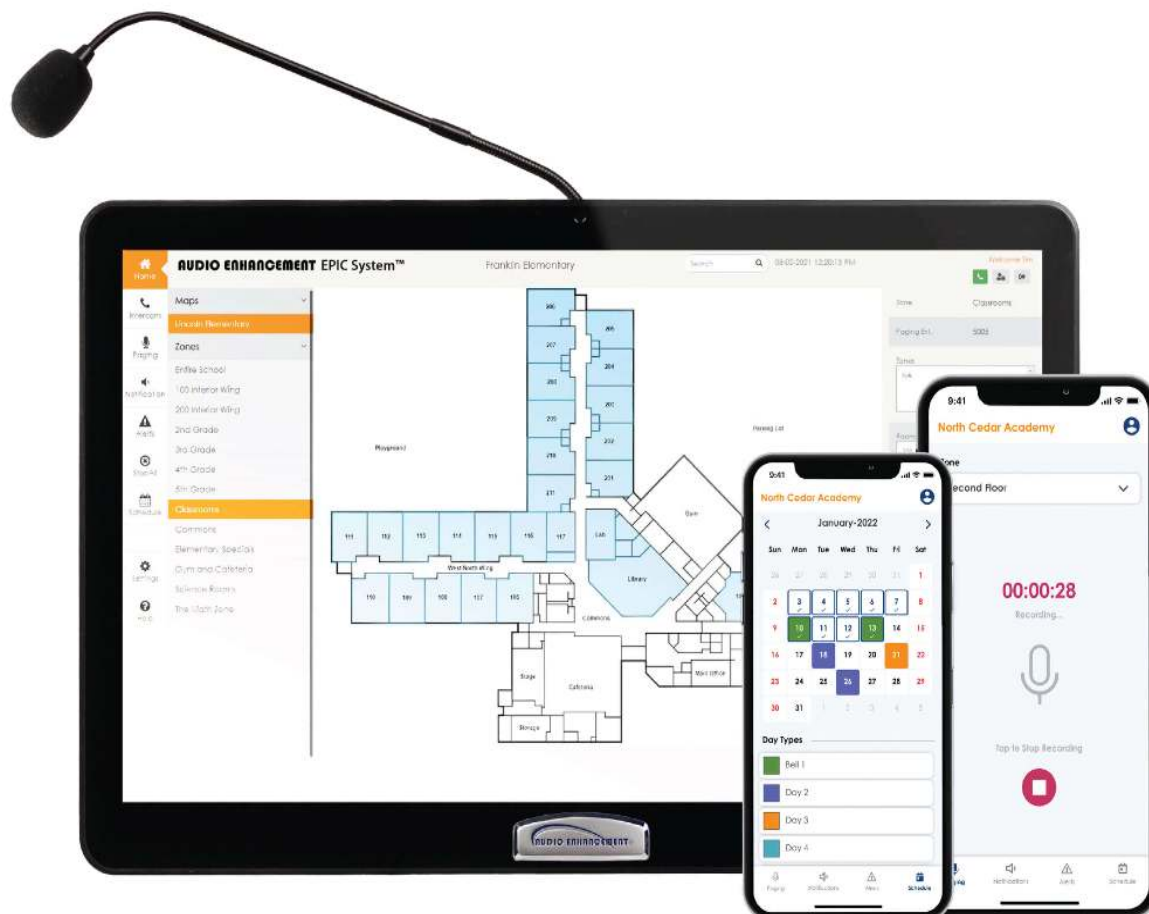

EPIC System

EPIC System allows schools to effectively and efficiently manage and schedule student movement within the school. By customizing bells and announcements on an individual classroom level, schools can eliminate unnecessary distractions to the learning environment, maximizing allocated learning time. EPIC system can be controlled from the Kiosk or the EPIC mobile app. Optional InfoView expands your EPIC System to include customizable classroom clocks, visual emergency notifications, and digital signage around your campus.

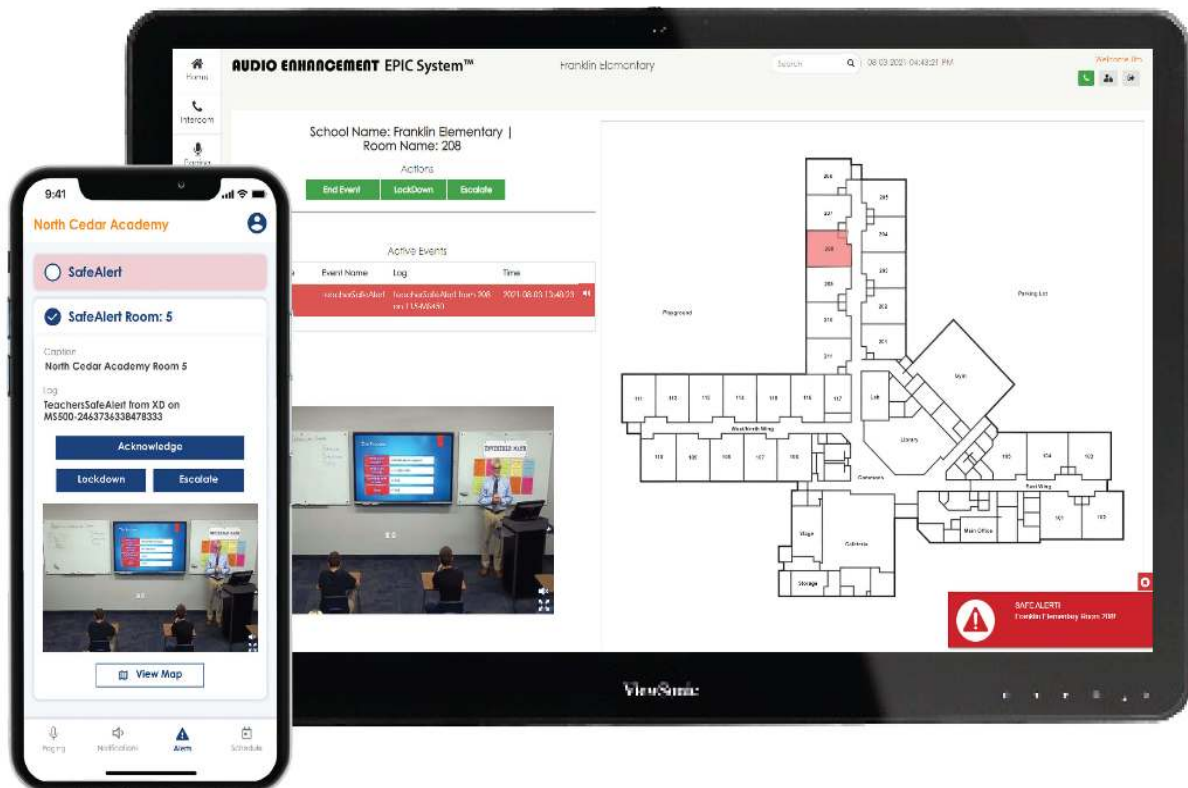

SAFE System

SAFE System™ (Signal Alert For Education) System™ is an alert and notification solution that connects teachers and classrooms to first responders for quick response and communication. The integration of SAFE System with our teacher microphone gives teachers a personal duress button to send alerts instantly from anywhere in the school. Office staff can discreetly acknowledge the alert, letting teachers know that help is on the way. The web-based interface gives administrators the ability to provide direction and maintain situational awareness of the entire campus, even in the most challenging emergency conditions. Give everyone on your campus peace of mind with the reassurance that SAFE is ready when seconds count.

Selected Systems and Products

4 Speaker Optimum System

QTY - 24

COMPATIBILITY



The MS-700 Optimum Amplifier is a fully integrated networked classroom amplifier and wireless microphone receiver. This amplifier has network-based intercom, paging and emergency notification, and provides full-duplex audio. It is easy-to-use, easy-to-install, and has simple user interface software. The entire unit utilizes Power over Ethernet (PoE+). Intercom and paging functionalities[†] are built-in. During emergencies, paging can still be heard, even when the power goes out.

INCLUDED COMPONENTS



Wiring Bundle for CA-30/60/70 Amplifiers



XD Teacher Box with Teacher Pendant and Student Handheld Microphone

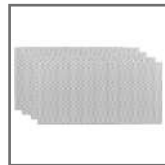

FS-22 Ceiling Speaker, 1x2 Tile Replacement, Plenum Rated, Set of 4



WBA-602 Call Button, Emergency Button, Ambient Mic with Access Panel



MS-700 Network Amp with Integrated XD Receiver with Programming

Full System Product Details

Wiring Bundle for CA-30/60/70 Amplifiers, XD Teacher Box with Teacher Pendant and Student Handheld Microphone, FS-22 Ceiling Speaker, 1x2 Tile Replacement, Plenum Rated, Set of 4, WBA-602 Call Button, Emergency Button, Ambient Mic with Access Panel, MS-700 Network Amp with Integrated XD Receiver with Programming.

8 Speaker Optimum System

QTY - 02

COMPATIBILITY



The MS-700 Optimum Amplifier is a fully integrated networked classroom amplifier and wireless microphone receiver. This amplifier has network-based intercom, paging and emergency notification, and provides full-duplex audio. It is easy-to-use, easy-to-install, and has simple user interface software. The entire unit utilizes Power over Ethernet (PoE+). Intercom and paging functionalities[†] are built-in. During emergencies, paging can still be heard, even when the power goes out.

INCLUDED COMPONENTS



75' Speaker Wire Plenum Rated, White



50' Speaker Wire Plenum Rated, White



Wiring Bundle for CA-30/60/70 Amplifiers



XD Teacher Box with Teacher Pendant and Student Handheld Microphone

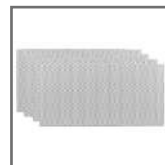

FS-22 Ceiling Speaker, 1x2 Tile Replacement, Plenum Rated, Set of 4

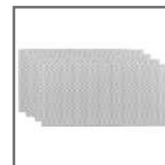

FS-22 Ceiling Speaker, 1x2 Tile Replacement, Plenum Rated, Set of 4

+ More

Full System Product Details

75' Speaker Wire Plenum Rated, White, 50' Speaker Wire Plenum Rated, White, Wiring Bundle for CA-30/60/70 Amplifiers, XD Teacher Box with Teacher Pendant and Student Handheld Microphone, FS-22 Ceiling Speaker, 1x2 Tile Replacement, Plenum Rated, Set of 4, FS-22 Ceiling Speaker, 1x2 Tile Replacement, Plenum Rated, Set of 4, WBA-602 Call Button, Emergency Button, Ambient Mic with Access Panel, MS-700 Network Amp with Integrated XD Receiver with Programming.

2nd Floor Hallway

QTY - 01

COMPATIBILITY



MS-300 Network Interface with 7' Cat6 & 3.5 to RCA Cables (KIT) used for paging. Also includes a variety of 70v Amplifier for areas with multiple 70v speakers like hallways, gyms, internal/external horns etc. Add optional wall plate for 2 way calling functionality.

INCLUDED COMPONENTS



EPIC Common Zone Amplifier 1 X 80W 70V, 1U HALF-RACK



MS-300 Network Interface with Programming (Requires PoE)

Full System Product Details

EPIC Common Zone Amplifier 1 X 80W 70V, 1U HALF-RACK, MS-300 Network Interface with Programming (Requires PoE),

First Floor Hallway

QTY - 01

COMPATIBILITY



MS-300 Network Interface with 7' Cat6 & 3.5 to RCA Cables (KIT) used for paging. Also includes a variety of 70v Amplifier for areas with multiple 70v speakers like hallways, gyms, internal/external horns etc. Add optional wall plate for 2 way calling functionality.

INCLUDED COMPONENTS



MS-300 Network Interface with Programming (Requires PoE)

Full System Product Details

MS-300 Network Interface with Programming (Requires PoE),



MS-300 Network Interface with 7' Cat6 & 3.5 to RCA Cables (KIT) used for paging. Also includes a variety of 70v Amplifier for areas with multiple 70v speakers like hallways, gyms, internal/external horns etc. Add optional wall plate for 2 way calling functionality.

INCLUDED COMPONENTS



EPIC Common Zone Amplifier 4 X 250W 70V - 1U



MS-300 Network Interface with Programming (Requires PoE)

Full System Product Details

EPIC Common Zone Amplifier 4 X 250W 70V - 1U, MS-300 Network Interface with Programming (Requires PoE),



MS-300 Network Interface with 7' Cat6 & 3.5 to RCA Cables (KIT) used for paging. Also includes a variety of 70v Amplifier for areas with multiple 70v speakers like hallways, gyms, internal/external horns etc. Add optional wall plate for 2 way calling functionality.

INCLUDED COMPONENTS



MS-300 Network Interface with Programming (Requires PoE)

Full System Product Details

MS-300 Network Interface with Programming (Requires PoE),



MS-300 Network Interface with 7' Cat6 & 3.5 to RCA Cables (KIT) used for paging. Also includes a variety of 70v Amplifier for areas with multiple 70v speakers like hallways, gyms, internal/external horns etc. Add optional wall plate for 2 way calling functionality.

INCLUDED COMPONENTS



MS-300 Network Interface with Programming (Requires PoE)

Full System Product Details

MS-300 Network Interface with Programming (Requires PoE),



MS-300 Network Interface with 7' Cat6 & 3.5 to RCA Cables (KIT) used for paging. Also includes a variety of 70v Amplifier for areas with multiple 70v speakers like hallways, gyms, internal/external horns etc. Add optional wall plate for 2 way calling functionality.

INCLUDED COMPONENTS



EPIC Common Zone Amplifier 1 X 300W 70V, 2U



MS-300 Network Interface with Programming (Requires PoE)

Full System Product Details

EPIC Common Zone Amplifier 1 X 300W 70V, 2U, MS-300 Network Interface with Programming (Requires PoE),

Virtual EPIC Head End System

QTY - 01

COMPATIBILITY



Everything you need in order for an EPIC System central head-end.

INCLUDED COMPONENTS



EPIC Grandstream Enterprise Phone with Programming



EPIC Kiosk with Programming



CLAUDIA, EPIC Front Office Media Player with Programming (Requires AC Power)



EPIC System Platform License



SAFE System License (Requires EP-0009)



EPIC System Intercom Paging & Bells License (Requires EP-0009)

Full System Product Details

EPIC Grandstream Enterprise Phone with Programming, EPIC Kiosk with Programming, CLAUDIA, EPIC Front Office Media Player with Programming (Requires AC Power), EPIC System Platform License, SAFE System License (Requires EP-0009), EPIC System Intercom Paging & Bells License (Requires EP-0009),

2 Speaker Optimum System

QTY - 01

COMPATIBILITY



The MS-700 Optimum Amplifier is a fully integrated networked classroom amplifier and wireless microphone receiver. This amplifier has network-based intercom, paging and emergency notification, and provides full-duplex audio. It is easy-to-use, easy-to-install, and has simple user interface software. The entire unit utilizes Power over Ethernet (PoE+). Intercom and paging functionalities[†] are built-in. During emergencies, paging can still be heard, even when the power goes out.

INCLUDED COMPONENTS



Wiring Bundle for CA-30/60/70 Amplifiers



XD Teacher Box with Teacher Pendant and Student Handheld Microphone

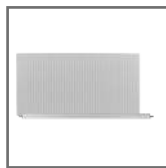

FS-22 Ceiling Speaker, 1x2 Tile Replacement, Plenum Rated, Set of 2



WBA-602 Call Button, Emergency Button, Ambient Mic with Access Panel



MS-700 Network Amp with Integrated XD Receiver with Programming

Full System Product Details

Wiring Bundle for CA-30/60/70 Amplifiers, XD Teacher Box with Teacher Pendant and Student Handheld Microphone, FS-22 Ceiling Speaker, 1x2 Tile Replacement, Plenum Rated, Set of 2, WBA-602 Call Button, Emergency Button, Ambient Mic with Access Panel, MS-700 Network Amp with Integrated XD Receiver with Programming,

Selected Systems and Products

25/70V Volume Control

QTY - 06



25 Watt 70V/100V/25V Rotary Volume Control white wall plate

70V Wall Mount Speaker, White

QTY - 07



70V Wall Mount Speaker in white.

70V Indoor Fixed Angled Horn Speaker and Enclosure

QTY - 06



This kit includes one 70 Volt H16 SVP angled front speaker and one SE2WVP slanted enclosure.

70V Outdoor Horn Speaker and Enclosure

QTY - 07



The SYSTEM 6VPS is a complete, vandal resistant horn assembly featuring a double re-entrant, compression horn with an integrated 16W, 25/70V, multi-tap transformer that is mounted on a vandal resistant, stainless steel baffle. It also includes a square, heavy gauge stainless steel, surface mount enclosure.

70V 2x2 Tile Replacement Speaker

QTY - 34



SYSTEM 19 is a complete, UL Listed, 2-way, shallow depth, lightweight, 2' x 2' lay-in ceiling tile replacement loudspeaker system consisting of an 6 1/2" O.D. woofer, 1" dome tweeter, and a 20W, 70V, rotary select transformer with an 8 Ohm position. The molded fiber enclosure is 1,283 CID. The SYSTEM 19 has a powder coated steel baffle with standard perforation and four (4) seismic tie-off points.



Lincoln Elementary

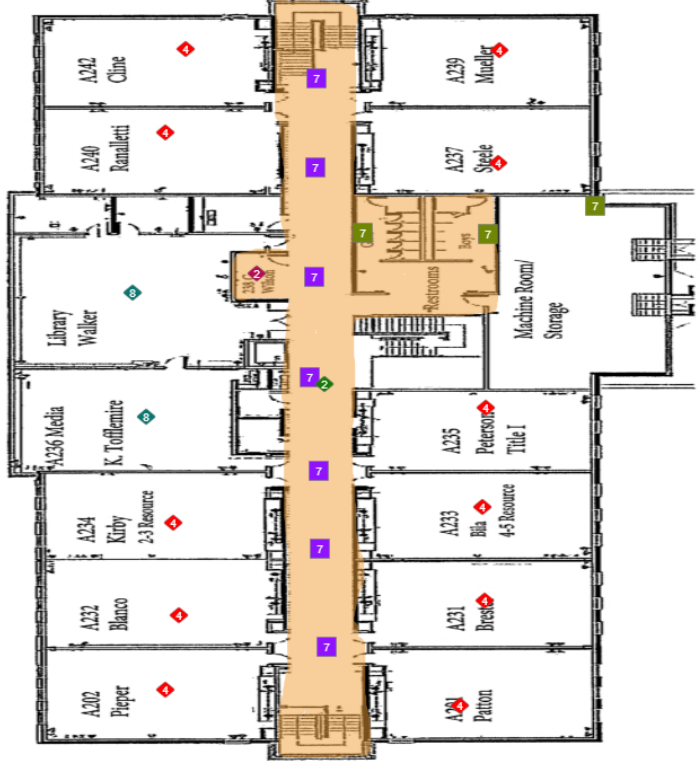

2ND FLOOR PLAN

Lincoln Elementary

Pricing Proposal

Pricing Valid for 90 Days - March 19, 2024



Quote **58607**

Gering Public Schools - NE - Gering Lincoln ES EPIC Audio SAFE

Classroom Equipment	\$87,134.64
EPIC System School Equipment	\$25,580.75
Services	\$50,104.00
Software Licensing	\$11,543.46
Training	\$5,900.00
<hr/>	
Discount	(\$36,952.62)
Taxes	\$0.00
Shipping	\$3,675.12
<hr/>	
Gering Public Schools Price	\$146,985.35

By sending in a Purchase Order in response to this proposal, the customer is agreeing to the Audio Enhancement terms and conditions which can be viewed at Audioenhancement.com/terms.

Audio Enhancement will invoice equipment at the time of shipment with payment due within terms. Services completed by Audio Enhancement will be invoiced upon substantial completion with payment due within terms.

If there are any questions about this process, please reach out to our Receivables Team – receivables@audioenhancement.com

*****Audio Enhancement will not be responsible for removal of existing equipment and cabling.*****

BoM 1

Part#	Product Name	Qty	Unit Price	Total
	Category : Classroom Equipment			
	System : 4 Speaker Optimum System			
CK-4010	Wiring Bundle for CA-30/60/70 Amplifiers	24	\$104.77	\$2,514.48
ST-XD-9060	XD Teacher Box with Teacher Pendant and Student Handheld Microphone	24	\$510.19	\$12,244.56
ST-SP-0211	FS-22 Ceiling Speaker, 1x2 Tile Replacement, Plenum Rated, Set of 4	24	\$381.88	\$9,165.12
NE-0016	WBA-602 Call Button, Emergency Button, Ambient Mic with Access Panel	24	\$110.60	\$2,654.40
AM-3250.P	MS-700 Network Amp with Integrated XD Receiver with Programming	24	\$2,096.64	\$50,319.36
	System : 8 Speaker Optimum System			
AC-0003	50' Speaker Wire Plenum Rated, White	2	\$25.83	\$51.66
CK-4010	Wiring Bundle for CA-30/60/70 Amplifiers	2	\$104.77	\$209.54
ST-XD-9060	XD Teacher Box with Teacher Pendant and Student Handheld Microphone	2	\$510.19	\$1,020.38
ST-SP-0211	FS-22 Ceiling Speaker, 1x2 Tile Replacement, Plenum Rated, Set of 4	2	\$381.88	\$763.76
ST-SP-0211	FS-22 Ceiling Speaker, 1x2 Tile Replacement, Plenum Rated, Set of 4	2	\$381.88	\$763.76
NE-0016	WBA-602 Call Button, Emergency Button, Ambient Mic with Access Panel	2	\$110.60	\$221.20
AM-3250.P	MS-700 Network Amp with Integrated XD Receiver with Programming	2	\$2,096.64	\$4,193.28
	System : 2 Speaker Optimum System			
CK-4010	Wiring Bundle for CA-30/60/70 Amplifiers	1	\$104.77	\$104.77
ST-XD-9060	XD Teacher Box with Teacher Pendant and Student Handheld Microphone	1	\$510.19	\$510.19
ST-SP-0212	FS-22 Ceiling Speaker, 1x2 Tile Replacement, Plenum Rated, Set of 2	1	\$190.94	\$190.94
NE-0016	WBA-602 Call Button, Emergency Button, Ambient Mic with Access Panel	1	\$110.60	\$110.60
AM-3250.P	MS-700 Network Amp with Integrated XD Receiver with Programming	1	\$2,096.64	\$2,096.64
	Category : EPIC System School Equipment			
	System : 8 Speaker Optimum System			
AC-0002	75' Speaker Wire Plenum Rated, White	2	\$32.57	\$65.14
	System : 2nd Floor Hallway			
AM-1003	EPIC Common Zone Amplifier 1 X 80W 70V, 1U HALF-RACK	1	\$563.85	\$563.85
ST-AM-8003.P	MS-300 Network Interface with Programming (Requires PoE)	1	\$657.33	\$657.33
	System : First Floor Hallway			

Part#	Product Name	Qty	Unit Price	Total
ST-AM-8003.P	MS-300 Network Interface with Programming (Requires PoE)	1	\$657.33	\$657.33
	System : Gym			
ST-AM-1025	EPIC Common Zone Amplifier 4 X 250W 70V - 1U	1	\$1,874.31	\$1,874.31
ST-AM-8003.P	MS-300 Network Interface with Programming (Requires PoE)	1	\$657.33	\$657.33
	System : Cafeteria			
ST-AM-8003.P	MS-300 Network Interface with Programming (Requires PoE)	1	\$657.33	\$657.33
	System : Admin			
ST-AM-8003.P	MS-300 Network Interface with Programming (Requires PoE)	1	\$657.33	\$657.33
	System : Exterior			
AM-1012	EPIC Common Zone Amplifier 1 X 300W 70V, 2U	1	\$1,050.00	\$1,050.00
ST-AM-8003.P	MS-300 Network Interface with Programming (Requires PoE)	1	\$657.33	\$657.33
	System : Virtual EPIC Head End System			
PA-0095.P	EPIC Grandstream Enterprise Phone with Programming	1	\$170.42	\$170.42
EP-0020.P	EPIC Kiosk with Programming	1	\$1,755.06	\$1,755.06
EP-0105.P	CLAUDIA, EPIC Front Office Media Player with Programming (Requires AC Power)	1	\$757.80	\$757.80
PA-0045	UPS 425VA 6-Outlet 120V for use with EPIC Kiosk	1	\$111.20	\$111.20
	Miscellaneous			
PA-0191	25/70V Volume Control	6	\$31.45	\$188.70
SP-1022	70V Wall Mount Speaker, White	7	\$103.33	\$723.31
SP-1094	70V Indoor Fixed Angled Horn Speaker and Enclosure	6	\$229.13	\$1,374.78
SP-1091	70V Outdoor Horn Speaker and Enclosure	7	\$249.60	\$1,747.20
SP-1095	70V 2x2 Tile Replacement Speaker	34	\$175.00	\$5,950.00
	Category : Services			
	System : Virtual EPIC Head End System			
SE-1002	EPIC Custom Map Development Services	1	\$525.00	\$525.00
SE-1047	Virtual Server Programming	1	\$1,700.00	\$1,700.00
SE-1043	EPIC System Third Party System Integration	1	\$1,050.00	\$1,050.00
SE-1024	Engineering and Design Services	1	\$1,495.00	\$1,495.00
	Category : Software Licensing			
	System : Virtual EPIC Head End System			
EP-0009	EPIC System Platform License	1	\$5,054.40	\$5,054.40

Part#	Product Name	Qty	Unit Price	Total
EP-0010	SAFE System License (Requires EP-0009)	1	\$3,994.10	\$3,994.10
EP-0022	EPIC System Intercom Paging & Bells License (Requires EP-0009)	1	\$1,460.16	\$1,460.16
EP-0034	EPIC Phone Integration License	1	\$1,034.80	\$1,034.80
	Category : Training			
	System : Virtual EPIC Head End System			
EP-0035	EPIC Administrator Training	1	\$500.00	\$500.00
EP-0019	EPIC Experience Training	1	\$5,400.00	\$5,400.00

Quote **58607**

Additional BOM Items

Part#	Product Name	Qty	Unit Price	Total
	Category : EPIC System School Equipment			
AC-0004	18/2 Spooled Speaker Wire Plenum Rated Per Foot, White	5000	\$0.71	\$3,550.00
SE-0083.	Install Supply Kit	27	\$65.00	\$1,755.00
	Category : Services			
SE-0012	Lift Rental	1	\$550.00	\$550.00
SE-0067	Optional Contingency	69	\$100.00	\$6,900.00
SE-0025	Travel Services	1	\$1,650.00	\$1,650.00
SE-0073	Project Management Services	34	\$120.00	\$4,080.00
SE-1068	Installation of 70V Equipment	60	\$257.00	\$15,420.00
SE-0032	Commissioning Service	34	\$110.00	\$3,740.00
SE-0080	Installation of Kiosk	1	\$172.00	\$172.00
SE-0035	Installation of Audio System	27	\$416.00	\$11,232.00
SE-0038	Installation of MS-300 for Common Zone Amplifier	6	\$265.00	\$1,590.00



**Product
Spec Sheets**

Specifications

Power Output	40W/80W/120W
Output Channels	1
Input Sensitivity	1.4Vrms for 8-ohms
Phantom Power	27VDC
AC Line Voltage	100 - 240V, 50/60 Hz
Input Impedance	20K ohms/50K ohms
Dimensions	1.7" x 8.6" x 11.9" (43.3mm x 218.5mm x 303.4mm)
Included Accessories	Rack mounting kit

Performance	CSA 1300Z	CSA 2300Z
Rated Power into 4 Ω or 8 Ω ; 1kHz, \leq 0.5% THD	300W	300W
Number of Output Channels	1	2
Insertion Loss (70V & 100V outputs)	1 dB maximum	
Input Sensitivity (8 Ω Load)	Balanced line input: 775mV _{RMS} ; RCA Mono Sum input: 300mV _{RMS}	
Frequency Response (8 Ω , 20Hz - 20kHz, tone ctrls set to flat response)	+/- 1.0 dB	
Total Harmonic Distortion (THD) (@ Full rated power, 20Hz-20kHz)	<0.5%	
Signal-to-Noise Ratio (Ref. rated output, 22kHz BW, A-weighted)	>97dB	
Input Impedance (nominal)	Euro Block: 20 k Ω (balanced); RCA: 10 k Ω	
Maximum Input Level	+22dBu (Nominal)	
Crosstalk (Ref. rated power, A-weighted, 1kHz)	<-70 dB	
Tone Controls (Bass and Treble non-detented potentiometers on each channel)	Bass +/-12dB @100Hz Treble +/-12dB @10kHz	
Nominal AC Line Voltages	100V, 120V, 220V, 230-240V, 50/60 Hz	
Minimum Load Impedance Low-Z Output 70V Output 100V Output	4 Ω 12 Ω 24 Ω	4 Ω 12 Ω 24 Ω
Operating Temperature/Humidity	0°C to 35°C @ 95% R.H. (non-condensing)	
Storage Temperature	-20°C to 85°C	
Dimensions & Weight		
Net Weight (preliminary estimate)	13.1 lb (5.95 kg)	17.8 lb (8.05 kg)
Dimensions	Width: 17.0 in. (432 mm) Depth: 10.8 in. (274 mm) Height: 3.5 in. (89 mm)	
Shipping Weight	16.4 lb (7.45 kg)	20.6 lb (9.35 kg)



GXP2130 v2

A flexible Enterprise IP Phone

The GXP2130 v2 is a standard enterprise-grade IP phone that features up to 3 lines, 4 XML programmable soft keys, 8 programmable BLF extension keys, dual Gigabit network ports and 4-way voice conferencing. This Enterprise IP Phone comes equipped with Bluetooth, Electronic Hook Switch (EHS) support for Plantronics headsets to allow for flexibility. Ideal for SMBs, enterprises and SOHOs, the GXP2130 v2 is the perfect choice for users looking for a high quality, feature rich IP phone with advanced functionality that is simple to use.



3 lines, with up to 3 SIP accounts, 3 dual-colored line keys



Dual-switched auto-sensing 10/100/1000mbps network ports



Includes 8 dual-colored BLF/speed dial keys



Built-in Bluetooth for syncing headsets and mobile devices for contact books, calendars & call transferring



HD audio to maximize audio quality and clarity, full-duplex speakerphone



Built-in PoE to power the device and give it a network connection



Electronic Hook Switch (EHS) support for Plantronics headsets



Automated provisioning options include TR-069 and XML config files



TLS and SRTP security encryption technology to protect calls and accounts



4-way audio conferencing for easy conference calls

Protocols/Standards	SIP RFC3261, TCP/IP/UDP, RTP/RTCP, HTTP/HTTPS, ARP, ICMP, DNS (A record, SRV, NAPTR), DHCP, PPPoE, TELNET, TFTP, NTP, STUN, SIMPLE, LLDP, LDAP, TR-069, 802.1x, TLS, SRTP, IPv6
Network Interfaces	Dual switched auto-sensing 10/100/1000 Mbps Gigabit Ethernet ports with integrated PoE
Graphic Display	2.8 inch (320x240) TFT color LCD
Bluetooth	Yes, Bluetooth V2.1
Feature Keys	3 line keys with up to 3 SIP accounts, 8 speed-dial/BLF extension keys with dual-color LED, 4 programmable context sensitive softkeys, 5 navigation/menu keys, 11 dedicated function keys for: MESSAGE (with LED indicator), PHONEBOOK, TRANSFER, CONFERENCE, HOLD, HEADSET, MUTE, SEND/REDIAL, SPEAKERPHONE, VOL+, VOL-
Voice Codexs	Support for G.729A/B, G.711 μ /a-law, G.726, G.722 (wide-band), in-band and out-of-band DTMF (in audio, RFC2833, SIP INFO)
Auxiliary Ports	RJ9 headset jack (allowing EHS with Plantronics headsets), USB
Telephony Features	Hold, transfer, forward, 4-way audio conference, call park, call pickup, shared-call-appearance (SCA)/bridged-line-appearance (BLA), downloadable phonebook (XML, LDAP, up to 2000 items), call waiting, call log (up to 500 records), customization of screen, off-hook auto dial, auto answer, click-to-dial, flexible dial plan, hot desking, personalized music ringtones and music on hold, server redundancy and fail-over
Sample Applications	Weather, currency, news, XML
HD Audio	Yes, both on handset and speakerphone
Base Stand/Wall Mountable	Yes, allow 2 angle positions
QoS	Layer 2 (808.1Q, 802.1p) and Layer 3 (ToS, DiffServ, MPLS) QoS
Security	User and administrator level passwords, MD5 and MD5-sess based authentication, AES based secure configuration file, SRTP, TLS, 802.1x media access control
Multi-language	English, Arabic, Chinese, Croatian, Czech, Dutch, German, French, Hebrew, Hungarian, Italian, Japanese, Korean, Polish, Portuguese, Russian, Slovenia, Spanish, Turkish
Upgrade/Provisioning	Firmware upgrade via TFTP/HTTP/HTTPS, mass provisioning using TR-069 or encrypted XML configuration file
Power & Green Energy Efficiency	Universal power adapter included: Input: 100-240VAC; Output: +12VDC, 0.5A (6W) Integrated PoE (Power-over-Ethernet) 802.3af, Class 2
Physical	Dimension: 193mm (W) x 211mm (L) x 85mm (H) Unit weight: 0.81kg; Package weight: 1.44kg
Temperature and Humidity	0 ~ 40°C (32 ~ 104°F), 10 ~ 90% (non-condensing)
Package Content	GXP2130 phone, handset with cord, base stand, universal power supply, network cable, Quick Start Guide
Compliance	FCC Part 15 ClassB, EN55022 ClassB, EN61000-3-2, EN61000-3-3, EN55024, EN60950-1, EN62479 RCM: AS/ACIF S004; AS/NZS CISPR22/24; AS/NZS 60950

Classroom CLAUDIA



Front

Front Office CLAUDIA



Front

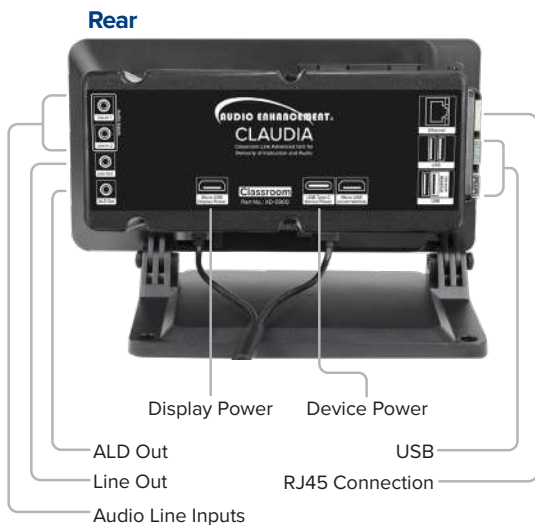

Rear

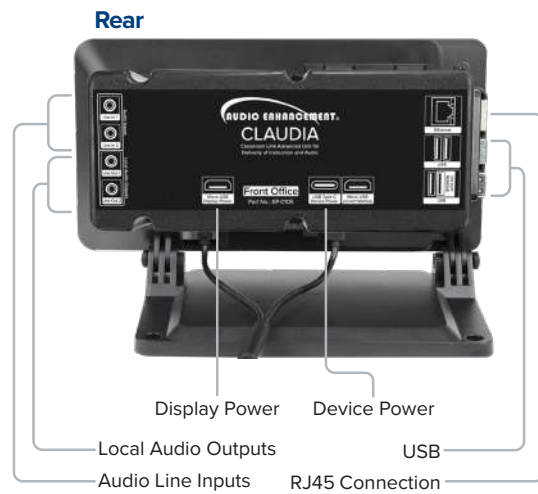

Rear

CLAUDIA in your Classroom

CLAUDIA provides connectivity and control of the local sound system from an easy to use touchscreen interface right at the teacher's desk. The teacher can connect their computer through the integrated audio input or a device such as their phone through the advanced Bluetooth® Link technology. Additionally, it provides simple integration for use with teleconference services such as Zoom, Google Meets™, and other platforms used for remote learning. Optional features such as SAFE (Signal Alert For Education) System® alerts and VIEWpath® (Video Interactive Education Window) recordings can be activated directly from the 7" touchscreen interface.

CLAUDIA in your Front Office

CLAUDIA in your front office provides an easy interface for streaming music to designated parts of your campus through EPIC System. CLAUDIA will allow music to be played from a local device connected directly, or through a device using the advanced Bluetooth® Link technology. CLAUDIA will also store 200+ songs directly on the device which can be played directly from the 7" touchscreen interface.



Features

- Wireless connectivity to your installed XD Classroom Audio System provides 2-way audio between CLAUDIA and the installed XD Classroom Audio System
- Connect a Bluetooth® device to any Audio Enhancement XD Classroom Audio System through CLAUDIA
- Audio sources such as the teacher's computer, large front of classroom display, or tablet device can be integrated wirelessly between CLAUDIA and the installed XD Classroom Audio System
- 7" Touchscreen display provides for an easy user interface to manage all functions of CLAUDIA
- Managed Bluetooth®: through the web interface, the broadcast name of the CLAUDIA system can be customized to more easily manage to which unit a teacher's device is connected
- Multiple Inputs/Outputs: CLAUDIA provides 2 line level inputs and outputs ensuring that both educational functions and assistive listening applications can be accommodated at the same time

CLAUDIA Specifications*

Power Supply	USB-C Power Supply (Included) 5.1 Volt 3.5 Amp 5ft Power Cable (18 AWG) UL Listed
Touchscreen	7" Capacitive touch display Resolution: 800 x 480 Full Color Display Size: <ul style="list-style-type: none"> • Physical Screen Size: 4.33 (H) x 7.63 (W) x 0.78 (D) in. (110 x 194 x 20 mm) • Viewable Screen Size: 3.38 (H) x 6.10 (W) (86 x 155 mm)
System Specifications	
Processor	Broadcom BCM2711, quad-core Cortex-A72 (ARM v8) 64-bit SoC @ 1.5GHz
Memory	2GB
Connectivity	2.4 GHz and 5.0 GHz IEEE 802.11b/g/n/ac wireless Bluetooth® 5.0 Gigabit Ethernet 2 x USB 3.0 ports 2 x USB 2.0 ports
Environment	Operating temperature 32–120°F (0–50°C)
Audio Input	2 X 3.5mm Line Level Inputs with independent volume control Bluetooth® Audio
Audio Output	2 x 3.5mm Line Level Outputs with independent volume control
Wireless Transceiver	XD Technology 1.9 GHz DECT Based Wireless Transceiver (Classroom version only)
Temperature/Humidity	Storage: -40 to 158°F (-40 to +70°C) / 10-90% non-condensing Operating: -32-122°F (0 to +50°C) / 10-90%
Weight	1.5 lbs (0.68 kg)
Dimensions	5.50 (H) x 8.75 (W) x 4.125 (D) in. (Fully Upright) (139.7 x 222.25 x 104.78 mm)

* All specifications subject to change.



Share:



BE425M

Average Customer Review 5

36 of 36 (100%) reviewers would recommend this product to a friend.

[Read all reviews](#) | [Write a review](#)

Share this Product:



Description: Battery Backup & Surge Protector for Electronics and Computers

Includes : User Manual

Product Overview

Technical Specifications

Documentation

Options

Ratings & Reviews

Output

[Print Technical Specification](#)

Output power capacity	255Watts / 425VA
Max Configurable Power (Watts)	255Watts / 425VA
Nominal Output Voltage	120V
Output Frequency (sync to mains)	50/60Hz +/- 3 Hz
Topology	Standby
Waveform type	Square wave
Output Connections	
(4) NEMA 5-15R (Battery Backup)	
(2) NEMA 5-15R (selector_surgetitle)	
Transfer Time	6ms typical : 10ms maximum

Input

Nominal Input Voltage	120V
Input frequency	50/60 Hz +/- 3 Hz (auto sensing)
Input Connections	NEMA 5-15P
Cord Length	5ft (1.52meters)
Input voltage range for main operations	88 - 139V
Number of Power Cords	1
Maximum Input Current	5.0A

Batteries & Runtime

Battery type	Maintenance-free sealed Lead-Acid battery with suspended electrolyte : leakproof	
Typical recharge time	8hour(s)	
Expected Battery Life (years)	3 - 5	
Runtime	View Runtime Graph	View Runtime Chart
Efficiency	View Efficiency Graph	

Communications & Management

Control panel	LED Status display with On Line : On Battery
Audible Alarm	Alarm when on battery : distinctive low battery alarm

Surge Protection and Filtering

Surge energy rating	180Joules
---------------------	-----------

Physical

Maximum Height	5.52inches (140mm , 14.02CM)
Maximum Width	9.98inches (253mm , 25.35CM)
Maximum Depth	4.13inches (105mm , 10.5CM)
Net Weight	5.73lbs. (2.6KG)
Shipping weight	6.61lbs. (3.0KG)
Shipping Height	8.66inches (220mm , 22.0CM)

Shipping Width	12.4inches (315mm , 31.5CM)
Shipping Depth	5.51inches (140mm , 14.0CM)
Color	Black
Master Carton Units	2.0
Master Carton Weight	14.33lbs. (6.5)
Units per Pallet	96.0
SCC Codes	1073130432934 0

Environmental

Operating Temperature	32 - 104 °F (0 - 40 °C)
Operating Relative Humidity	0 - 95 %
Operating Elevation	0-10000ft (0-3000meters)
Storage Temperature	-20 - 50 °C
Storage Relative Humidity	0 - 95 %
Storage Elevation	0-50000ft (0-15000meters)
Audible noise at 1 meter from surface of unit	40.0dBA

Conformance

Approvals	California (CEC) Battery Charger, cTUVus, ENERGY STAR V1.0 (USA), FCC Part 15 Class B
Equipment protection policy	Lifetime : \$75000
Standard warranty	3 years repair or replace

Sustainable Offer Status

RoHS	Compliant
REACH	REACH: Contains No SVHCs



Audio Enhancement's

Upcoming EPIC Experience Training

EPIC Experience training is designed to help school districts get the most out of their EPIC System's intercom, paging, bells and notifications capabilities, back-end administrative event management, SAFE System, and VIEWpath. Participants will learn about device installation, programming, setup, maintenance, and troubleshooting.

Only \$5,400 per attendee: Flights, Lodging, transportation, and meals are included in cost.

EPIC Experience Schedule

Monday	Travel Day
Tuesday	Classroom Audio System devices and connections, EPIC System devices and connections, and labs.
Wednesday	Network and configuration, EPIC Maps and Bells, labs, EPIC roles and permissions, and backups.
Thursday	Notifications, EPIC Events and logs, SAFE alerts, AND Devices & strobes, VIEWpath devices and software, troubleshooting, labs, and resources.
Friday	Travel Day



Scan for More Info
and Registration

Side View



Front View

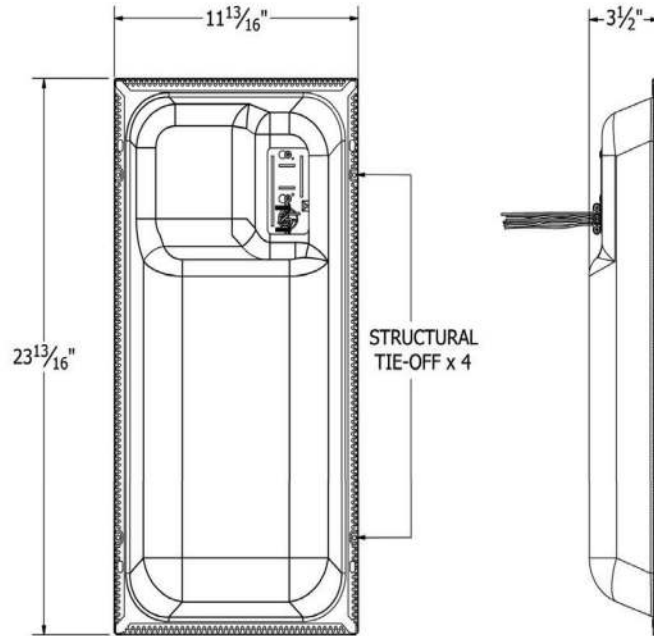
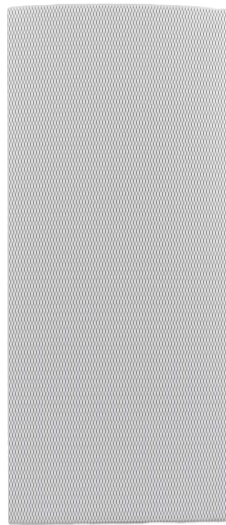

Back View



Tie-Off Tabs

Wiring Access

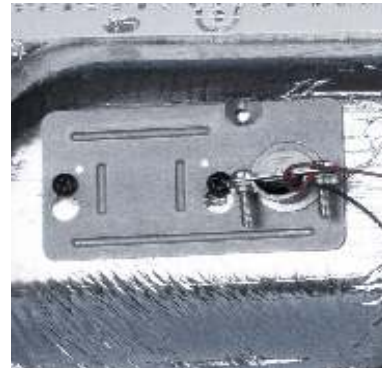

The **FS-22 Flat Panel Speaker** is a custom, fully assembled speaker. Enjoy crystal-clear audio in schools and district buildings. This speaker is designed to be a ceiling tile replacement speaker and fits into a standard grid ceiling. A replacement 24", "T" rail is included, allowing the installer to make one simple cut across a tile to create the 1-foot opening for the speaker. Includes four (4) secure tie-off tabs for additional security. Meets UL2043 criteria for plenum installation.



Speaker Specifications



Frequency Response	70 Hz - 15 kHz (-10 dB) 100 Hz - 14 kHz +/-2 dB
Power Handling	50 W continuous pink noise
Sensitivity	88 dB (1W/1M)
Impedance	8 Ohm nominal
Mounting	Lay in, four tie-off tabs for additional mounting integrity (1) 24", "T" rail included
Plenum Rated Back Can	Speaker back can meets UL2043 criteria for plenum installation
Speaker Wire Terminals	Speaker wires
Weight	4.6 lbs. (1.2 kg)
Dimensions	Height 24 in. (609.6 mm) Width 12 in. (304.8 mm) Depth 3.75 in. (95.25 mm)



Back can is RoHS and UL compliant.



Audio Enhancement, Inc. is pleased to offer the following warranty.

A standard Five (5) year limited manufacturer's warranty ("Limited Warranty") against malfunction due to manufacturing defects in materials or workmanship on the IR and XD teacher and student microphone, XD receiver (K-SRC14), CA-30, CA-60, GL-300, Hydra II, XDSolo™, BEAM, BEAM Pro, Handheld Microphone Holder, and Ceiling and Wall speakers ("Audio Enhancement Products"). The Limited Warranty applies only if: (1) the Audio Enhancement Products are installed according to manufacturer's instruction provided to Customer and (2) the Audio Enhancement Products are not misused or abused, and there is no evidence of mishandling, neglect, modification, or repair without the approval of Audio Enhancement.

A standard three (3) year limited manufacturer's warranty ("Limited Warranty") against malfunction due to manufacturing defects in materials or workmanship on the EduCam360, EduCam 360-A, EduCam360-B, EduCam360-C, EduCamPTZ, EduCamPTZ-B, MS-1000 Monitoring Station (MS-1000), AVConnect (HDBaseT), SAFE System, EPIC System Server, MS-300, MS-500, and CLAUDIA. The Limited Warranty applies only if (1) the Audio Enhancement product is installed according to manufacturer's instructions and by an Audio Enhancement certified installer and (2) the Audio Enhancement Products are not misused or abused, and there is no evidence of mishandling, neglect, modification, or repair without the approval of Audio Enhancement.

A standard one (1) year limited manufacturer's warranty ("Limited Warranty") against malfunction due to manufacturing defects in materials or workmanship on our General Electronics (including but not limited to: NVRs, Classroom Wall Box, MS-400, Hydra Adapter (SC-12-24VACDC), Wall Plate Accessories (WPA), Alert Notification Button, Mic360™, UPS (Uninterrupted Power Supply)), specialty cables and adapters. EPIC System Console Touchscreen, Server Drives, and EPIC System Console Paging Microphone. The Limited Warranty applies only if (1) the General Electronics is installed according to manufacturer's instructions and by an Audio Enhancement certified installer and (2) the General Electronics has not been misused or abused, and there is no evidence of mishandling, neglect, modification or repair without the approval of the manufacturer.

The EduCam390 camera SD card and 'AA' NiMH and lithium-ion batteries supplied by Audio Enhancement, Inc., carry a 90-day warranty from date of purchase.

The following is not included under this Limited Warranty: (1) Misuse or abuse by the Customer; (2) normal wear and tear; (3) physical damage to Audio Enhancement's Products because of unreasonable use and/or negligence; and (4) damage caused by service or repairs by the customer or a person who is not authorized for such service or repairs by Audio Enhancement.

This Limited Warranty is provided by Audio Enhancement, and it contains the only express warranty provided to Customer by Audio Enhancement. Audio Enhancement does not authorize any other person, including distributors, to give any other warranties on

Audio Enhancement's behalf. The repair or replacement as provided under the express limited warranty is the sole and exclusive remedy of the Customer and Audio Enhancement's sole and exclusive liability hereunder.

Audio Enhancement disclaims any express warranty not provided herein and any implied warranty, guarantee, or representation as to performance, quality and absence of hidden defects, and any remedy for breach of contract, which but for this provision, might arise by implication, operation of law, custom of trade or course of dealing, including implied warranties of merchantability and fitness for a particular purpose. In no event shall Audio Enhancement be liable, whether in contract, tort (including negligence) or otherwise, for damages more than the purchase price of the product giving rise to the damages, or for any direct, indirect, incidental, special, punitive, exemplary, or consequential damages of any kind. Audio Enhancement further disclaims any responsibility for losses, expenses, inconveniences, special, indirect, secondary, or consequential, incidental, and contingent damages whatsoever, including damages arising from ownership or use of Audio Enhancement's products.

Audio Enhancement shall bear no responsibility or obligation with respect to the manner of use of any equipment sold by Audio Enhancement.

Audio Enhancement specifically disclaims and negates any warranty of fitness for a particular purpose of such equipment including, without limitation, any warranty that the use of such equipment for any purpose will comply with applicable laws and regulations or overcome any specific hearing/auditory processing deficit. When returning units for service, use adequate packaging to prevent shipping damage. Shipping damage is not covered under warranty.



Technical Support

Audio Enhancement Technical Support Representatives are available to assist by phone, chat, and email. With offices in West Jordan, Utah; Apopka, Florida; and Alpharetta, Georgia, we offer additional regional resources to ensure our local customers have all the support to meet their needs. Here is our companies technical support information and FAQ's.

Contact Support:

Hours: Monday-Friday 8:00am-7:00pm EST.

Phone: 800.932.3578

Email: Support@AudioEnhancement.com

Chat and RMA: www.AudioEnhancement.com/Support/

Additional Support:

Training Website: www.training.AudioEnhancement.com

YouTube Site: www.youtube.com/user/AudioEnhancementInc

Support Levels:

Level 1 Level 1 support is for basic audio systems. Tickets are created when a phone call is made, RMA is submitted, or an email is sent to support. Level 1 support services include troubleshooting with microphones, batteries, cabling, volume levels, information requests, and basic EPIC troubleshooting and setup.

Level 2 When a higher level of support is required, tickets are escalated to Level 2 support. This type of support includes advanced audio troubleshooting. Enhanced EPIC support including device configuration, SIP integration, LDAP integration, and configuration of VIEWPath and VIEWPath Live.

Level 3 Level 3 support is for final escalations and is handled by Audio Enhancement engineers and developers with 10+ years of experience.

Additional Support Personnel:

Audio Enhancement headquarters is located in West Jordan, Utah with two satellite offices in Apopka, Florida and Alpharetta, Georgia. Between our three offices and field services reps across the country, Audio Enhancement can provide additional onsite support when needed.

Project Information

- **Project Summary ***
NE - Gering Lincoln ES EPIC Audio SAFE
- **Opportunity Number**
23647
- **Request design team to design your school? ***
No
- **Will this project be using a Contract? ***
No
- **Will Audio Enhancement be Installing? ***
Yes
- **Does this project utilize Davis Bacon rates or Prevailing Wage?**
No
- **Site Status at Any Point During Implementation ***
None of the above
- **Are there any drawings or specifications we are required to meet for this project? ***
No

This proposed design was finalized by Audio Enhancement. The customer approval of original design was bypassed by Taylor Noyes at 20 Dec, 2023 5:59 PM.

Explanation:

Approved by Nicole Regan via email., Bypassed by Taylor Noyes on 20 Dec, 2023 5:59 PM

Audio Enhancement Solutions Proposal



December 20, 2023

Proposal ID# 114571
SAP Quote# 58611

Prepared For Gering Public Schools



Dear Gering Public Schools,

I want to personally thank you for inviting us to submit a proposal to Gering Public Schools!

When my mother, Claudia Anderson, founded Audio Enhancement over 40 years ago, we never imagined the impact our services would have on education today. Through customer feedback, we have grown from offering classroom audio solutions to providing district-wide communication and safety technology. We have impacted over 4,000 districts, 39,000 schools, and over 1,200,000 classrooms across the world. We are excited for the opportunity to help you!

Our team focuses on hiring employees with a passion to make a difference in education. We look forward to developing a deeper partnership with Gering Public Schools through building friendship and trust during the ongoing stages of your project.

It is our pleasure to submit this proposal to Gering Public Schools. As with all proposals, revisions can be made at any time.

We look forward to your response and are available to answer any questions during the review process.

From all of us here at Audio Enhancement, thank you!

Sincerely yours,



Jeff Anderson

Jeff Anderson
Audio Enhancement, CEO



Making a Difference in Education

For more than forty years, Audio Enhancement has served the schools throughout the United States, providing both classroom audio enhancement systems as well as integration services for classroom technology. Audio Enhancement is headquartered in Salt Lake City Utah and has facilities in Georgia and Florida.

Audio Enhancement was founded in 1978 by Claudia Anderson around the simple idea that “learning begins with hearing.” Having two hearing impaired children; the first Audio Enhancement systems were designed specifically for the hearing impaired. Early in our history, technological advancements made it possible to also provide whole classroom sound systems, benefiting all students. Audio Enhancement has been the innovator and leader in this field.

By 2004, it was clear that classroom audio enhancement systems were a key part of the overall technology landscape in the classroom. Based on our high level of support, outstanding customer service, and training that was provided for the audio systems, several school districts came to us and requested that we expand our product offerings. Based on these requests, we undertook an initiative to increase our capabilities in order to provide a complete integrated technology package for the classroom. These offerings include display devices, control, video/audio playback devices and interactive technologies. By utilizing the principles developed over thirty years of providing classroom audio systems to the schools, we were able to provide both technical integration, teacher in-servicing, training, and professional development to help the schools ensure the success of their technology goals.

Moving the company forward, in 2008, Audio Enhancement was incorporated: Jeff Anderson, President and CEO, Jennifer Crum, CFO, Jeremy Anderson, CAO and Justin Anderson, COO. Today, the Audio Enhancement product line improves student achievement, decreases teacher vocal fatigue and absenteeism, and creates positive student behavior. Audio Enhancement systems also increase focus and attention and supports classroom management.



The Anderson Family



Classroom Audio

A classroom Audio Enhancement system provides teachers with benefits seen in documented sound field system research with the consistency and clarity of the newest classroom technology—XD Audio. Teachers wear an XD Microphone with confidence of zero signal drop-outs. This delivers their voices to each student as clearly as if the teacher were sitting right next to them. With Classroom Audio, you can expect more time on task, fewer behavior issues, less teacher verbal repetition, and better content understanding. These provide an increase in actual instructional time, one thing every teacher can use more of. Clear and equitably distributed audio in the classroom contributes to the overall quality of instruction, targeting gaps in learning.

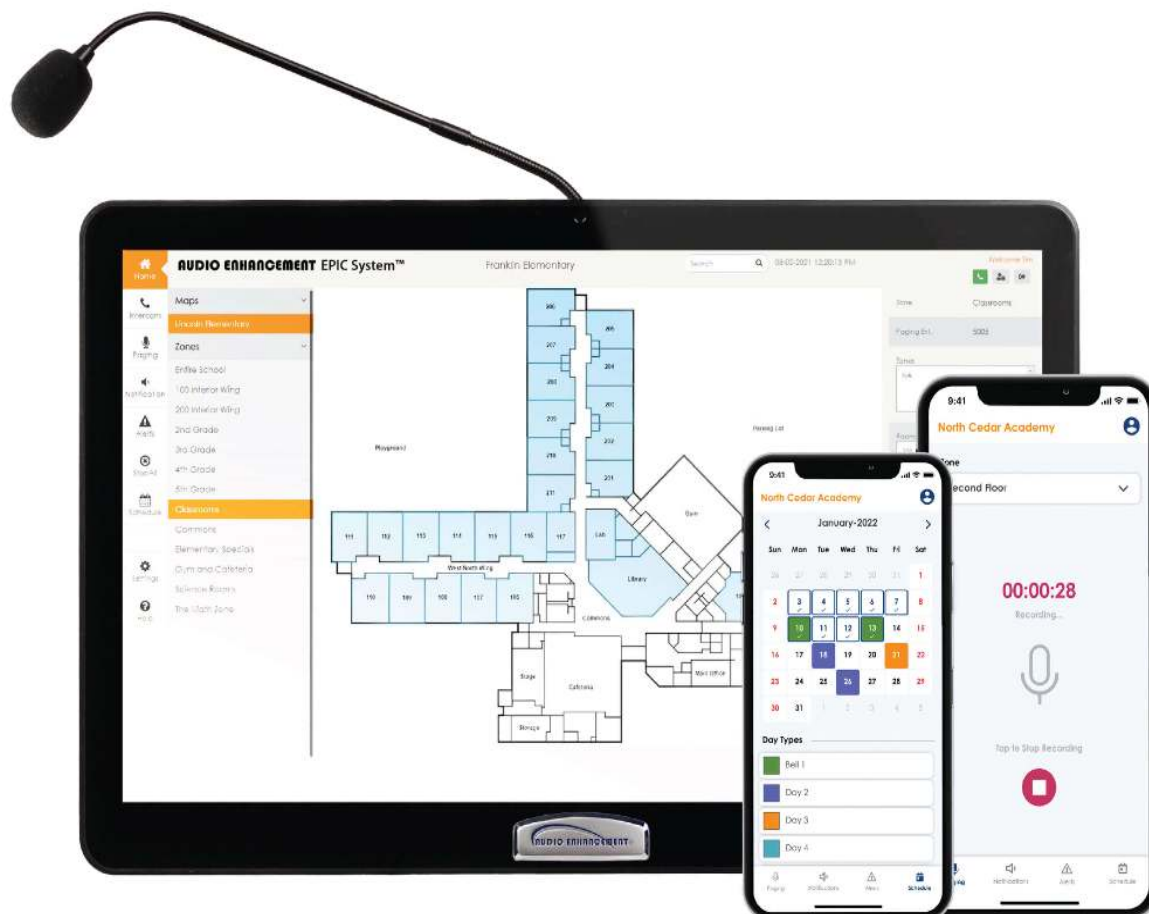

EPIC System

EPIC System allows schools to effectively and efficiently manage and schedule student movement within the school. By customizing bells and announcements on an individual classroom level, schools can eliminate unnecessary distractions to the learning environment, maximizing allocated learning time. EPIC system can be controlled from the Kiosk or the EPIC mobile app. Optional InfoView expands your EPIC System to include customizable classroom clocks, visual emergency notifications, and digital signage around your campus.

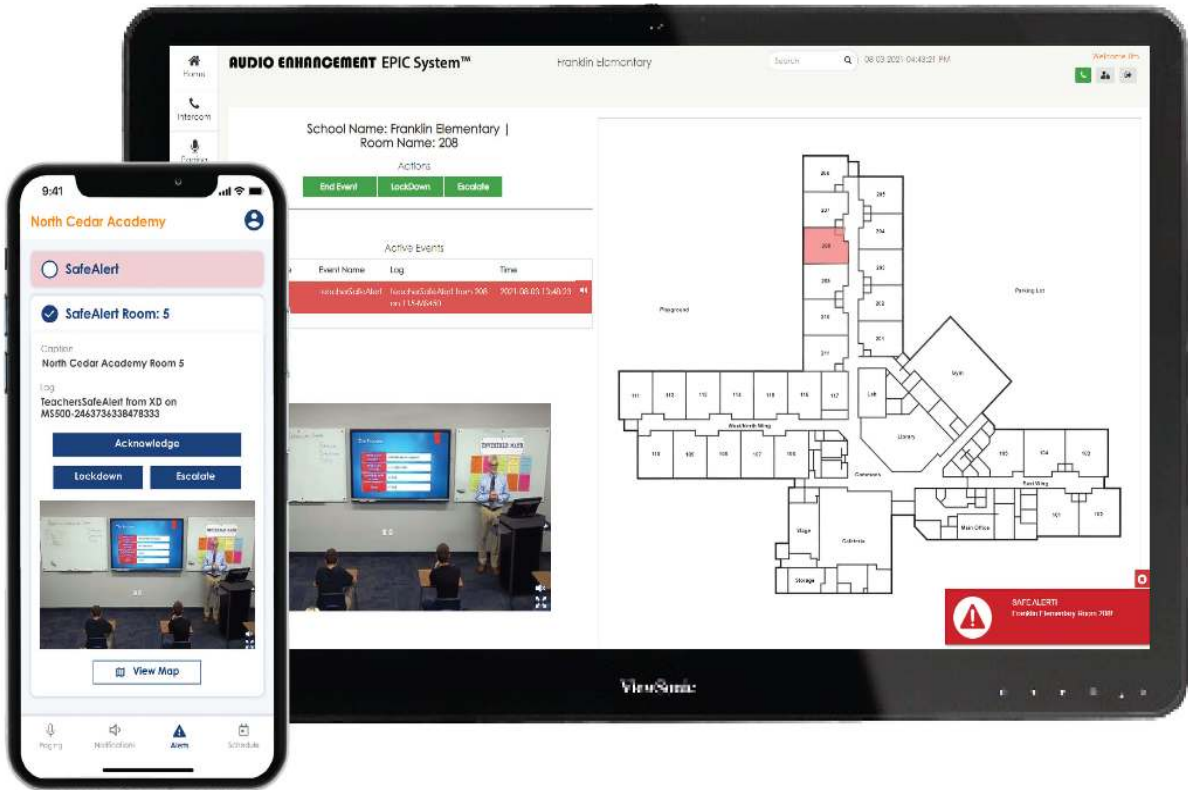

SAFE System

SAFE System™ (Signal Alert For Education) System™ is an alert and notification solution that connects teachers and classrooms to first responders for quick response and communication. The integration of SAFE System with our teacher microphone gives teachers a personal duress button to send alerts instantly from anywhere in the school. Office staff can discreetly acknowledge the alert, letting teachers know that help is on the way. The web-based interface gives administrators the ability to provide direction and maintain situational awareness of the entire campus, even in the most challenging emergency conditions. Give everyone on your campus peace of mind with the reassurance that SAFE is ready when seconds count.

Selected Systems and Products

4 Speaker Optimum System

QTY - 23

COMPATIBILITY



The MS-700 Optimum Amplifier is a fully integrated networked classroom amplifier and wireless microphone receiver. This amplifier has network-based intercom, paging and emergency notification, and provides full-duplex audio. It is easy-to-use, easy-to-install, and has simple user interface software. The entire unit utilizes Power over Ethernet (PoE+). Intercom and paging functionalities[†] are built-in. During emergencies, paging can still be heard, even when the power goes out.

INCLUDED COMPONENTS



Wiring Bundle for CA-30/60/70 Amplifiers



XD Teacher Box with Teacher Pendant and Student Handheld Microphone

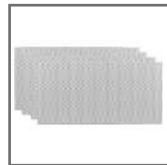

FS-22 Ceiling Speaker, 1x2 Tile Replacement, Plenum Rated, Set of 4



WBA-602 Call Button, Emergency Button, Ambient Mic with Access Panel



MS-700 Network Amp with Integrated XD Receiver with Programming

Full System Product Details

Wiring Bundle for CA-30/60/70 Amplifiers, XD Teacher Box with Teacher Pendant and Student Handheld Microphone, FS-22 Ceiling Speaker, 1x2 Tile Replacement, Plenum Rated, Set of 4, WBA-602 Call Button, Emergency Button, Ambient Mic with Access Panel, MS-700 Network Amp with Integrated XD Receiver with Programming.

8 Speaker Optimum System

QTY - 01

COMPATIBILITY



The MS-700 Optimum Amplifier is a fully integrated networked classroom amplifier and wireless microphone receiver. This amplifier has network-based intercom, paging and emergency notification, and provides full-duplex audio. It is easy-to-use, easy-to-install, and has simple user interface software. The entire unit utilizes Power over Ethernet (PoE+). Intercom and paging functionalities[†] are built-in. During emergencies, paging can still be heard, even when the power goes out.

INCLUDED COMPONENTS



75' Speaker Wire Plenum Rated, White



50' Speaker Wire Plenum Rated, White



Wiring Bundle for CA-30/60/70 Amplifiers



XD Teacher Box with Teacher Pendant and Student Handheld Microphone

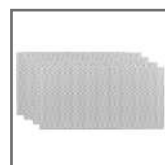

FS-22 Ceiling Speaker, 1x2 Tile Replacement, Plenum Rated, Set of 4

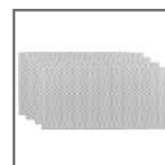

FS-22 Ceiling Speaker, 1x2 Tile Replacement, Plenum Rated, Set of 4

+ More

Full System Product Details

75' Speaker Wire Plenum Rated, White, 50' Speaker Wire Plenum Rated, White, Wiring Bundle for CA-30/60/70 Amplifiers, XD Teacher Box with Teacher Pendant and Student Handheld Microphone, FS-22 Ceiling Speaker, 1x2 Tile Replacement, Plenum Rated, Set of 4, FS-22 Ceiling Speaker, 1x2 Tile Replacement, Plenum Rated, Set of 4, WBA-602 Call Button, Emergency Button, Ambient Mic with Access Panel, MS-700 Network Amp with Integrated XD Receiver with Programming.



MS-300 Network Interface with 7' Cat6 & 3.5 to RCA Cables (KIT) used for paging. Also includes a variety of 70v Amplifier for areas with multiple 70v speakers like hallways, gyms, internal/external horns etc. Add optional wall plate for 2 way calling functionality.

INCLUDED COMPONENTS



EPIC Common Zone Amplifier 1 X 80W 70V, 1U HALF-RACK



MS-300 Network Interface with Programming (Requires PoE)



50' Cat6, Plenum Rated, Purple



Wall Plate, WPA-701, Ambient Mic with Decora Plate



Viking E-30-IP VoIP Entry Phone with Programming

Full System Product Details

EPIC Common Zone Amplifier 1 X 80W 70V, 1U HALF-RACK, MS-300 Network Interface with Programming (Requires PoE), 50' Cat6, Plenum Rated, Purple, Wall Plate, WPA-701, Ambient Mic with Decora Plate, Viking E-30-IP VoIP Entry Phone with Programming,

2-Way Intercom System with Programming (MS-320)



The MS-320 is a network interface that has intercom, paging and emergency notification, providing full-duplex audio. It is easy-to-use and easy-to-install. The entire unit is Powered over Ethernet (PoE). Intercom and paging functionalities** are built-in. During emergencies, paging can still be heard, even when the power goes out. This unit can be installed as part of the SAFE (Signal Alert For Education) System™.

INCLUDED COMPONENTS



MS-320 Network Interface for 2-Way Intercom with Programming (Requires PoE+)



Wiring Bundle for MS-600 Optimum Amplifier with Integrated XD Receiver

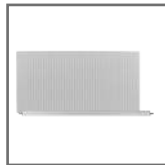

FS-22 Ceiling Speaker, 1x2 Tile Replacement, Plenum Rated, Set of 2



Wall Plate, WPA-702, Call Button, Emergency Button, Ambient Mic with Decora Plate

Full System Product Details

MS-320 Network Interface for 2-Way Intercom with Programming (Requires PoE+), Wiring Bundle for MS-600 Optimum Amplifier with Integrated XD Receiver, FS-22 Ceiling Speaker, 1x2 Tile Replacement, Plenum Rated, Set of 2, Wall Plate, WPA-702, Call Button, Emergency Button, Ambient Mic with Decora Plate,



MS-300 Network Interface with 7' Cat6 & 3.5 to RCA Cables (KIT) used for paging. Also includes a variety of 70v Amplifier for areas with multiple 70v speakers like hallways, gyms, internal/external horns etc. Add optional wall plate for 2 way calling functionality.

INCLUDED COMPONENTS



EPIC Common Zone Amplifier 1 X 300W 70V, 2U



MS-300 Network Interface with Programming (Requires PoE)

Full System Product Details

EPIC Common Zone Amplifier 1 X 300W 70V, 2U, MS-300 Network Interface with Programming (Requires PoE),



MS-300 Network Interface with 7' Cat6 & 3.5 to RCA Cables (KIT) used for paging. Also includes a variety of 70v Amplifier for areas with multiple 70v speakers like hallways, gyms, internal/external horns etc. Add optional wall plate for 2 way calling functionality.

INCLUDED COMPONENTS



EPIC Common Zone Amplifier 1 X 80W 70V, 1U HALF-RACK



MS-300 Network Interface with Programming (Requires PoE)

Full System Product Details

EPIC Common Zone Amplifier 1 X 80W 70V, 1U HALF-RACK, MS-300 Network Interface with Programming (Requires PoE),

Exterior Zone

QTY - 01

COMPATIBILITY



MS-300 Network Interface with 7' Cat6 & 3.5 to RCA Cables (KIT) used for paging. Also includes a variety of 70v Amplifier for areas with multiple 70v speakers like hallways, gyms, internal/external horns etc. Add optional wall plate for 2 way calling functionality.

INCLUDED COMPONENTS



EPIC Common Zone Amplifier 1 X 80W 70V, 1U HALF-RACK



MS-300 Network Interface with Programming (Requires PoE)

Full System Product Details

EPIC Common Zone Amplifier 1 X 80W 70V, 1U HALF-RACK, MS-300 Network Interface with Programming (Requires PoE),

East Hallway

QTY - 01

COMPATIBILITY



MS-300 Network Interface with 7' Cat6 & 3.5 to RCA Cables (KIT) used for paging. Also includes a variety of 70v Amplifier for areas with multiple 70v speakers like hallways, gyms, internal/external horns etc. Add optional wall plate for 2 way calling functionality.

INCLUDED COMPONENTS



EPIC Common Zone Amplifier 1 X 80W 70V, 1U HALF-RACK



MS-300 Network Interface with Programming (Requires PoE)

Full System Product Details

EPIC Common Zone Amplifier 1 X 80W 70V, 1U HALF-RACK, MS-300 Network Interface with Programming (Requires PoE),



Everything you need in order for an EPIC System central head-end.

INCLUDED COMPONENTS



EPIC Grandstream Enterprise Phone with Programming



EPIC Kiosk with Programming



CLAUDIA, EPIC Front Office Media Player with Programming (Requires AC Power)



EPIC System Platform License



SAFE System License (Requires EP-0009)



EPIC System Intercom Paging & Bells License (Requires EP-0009)

Full System Product Details

EPIC Grandstream Enterprise Phone with Programming, EPIC Kiosk with Programming, CLAUDIA, EPIC Front Office Media Player with Programming (Requires AC Power), EPIC System Platform License, SAFE System License (Requires EP-0009), EPIC System Intercom Paging & Bells License (Requires EP-0009),

Selected Systems and Products

25/70V Volume Control

QTY - 03



25 Watt 70V/100V/25V Rotary Volume Control white wall plate

70V Wall Mount Speaker, White

QTY - 08



70V Wall Mount Speaker in white.

70V Indoor Fixed Angled Horn Speaker and Enclosure

QTY - 02



This kit includes one 70 Volt H16 SVP angled front speaker and one SE2WVP slanted enclosure.

70V Outdoor Horn Speaker and Enclosure

QTY - 05



The SYSTEM 6VPS is a complete, vandal resistant horn assembly featuring a double re-entrant, compression horn with an integrated 16W, 25/70V, multi-tap transformer that is mounted on a vandal resistant, stainless steel baffle. It also includes a square, heavy gauge stainless steel, surface mount enclosure.

70V 2x2 Tile Replacement Speaker

QTY - 36



SYSTEM 19 is a complete, UL Listed, 2-way, shallow depth, lightweight, 2' x 2' lay-in ceiling tile replacement loudspeaker system consisting of an 6 1/2" O.D. woofer, 1" dome tweeter, and a 20W, 70V, rotary select transformer with an 8 Ohm position. The molded fiber enclosure is 1,283 CID. The SYSTEM 19 has a powder coated steel baffle with standard perforation and four (4) seismic tie-off points.

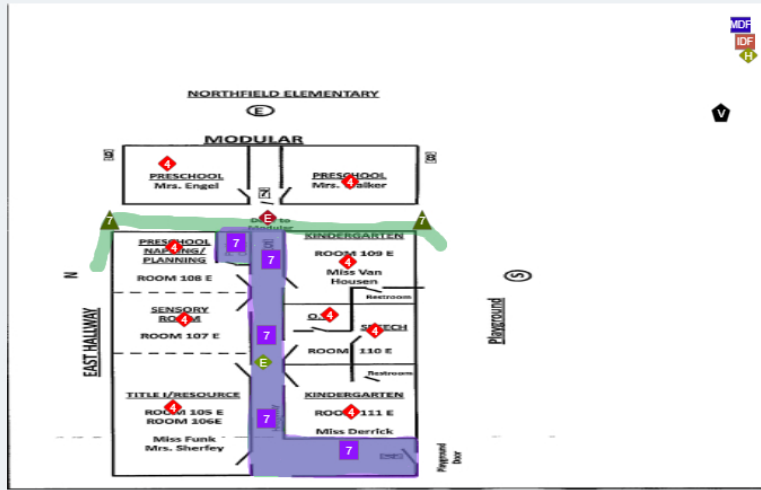

Pricing Proposal

Pricing Valid for 90 Days - March 19, 2024



Quote **58611**

Gering Public Schools - NE - Gering Northfield ES EPIC Audio SAFE

Classroom Equipment	\$79,487.95
EPIC System School Equipment	\$22,746.35
Services	\$46,450.00
Software Licensing	\$11,543.46
Training	\$5,900.00
<hr/>	
Discount	(\$33,524.66)
Taxes	\$0.00
Shipping	\$3,366.53
<hr/>	
Gering Public Schools Price	\$135,969.63

By sending in a Purchase Order in response to this proposal, the customer is agreeing to the Audio Enhancement terms and conditions which can be viewed at Audioenhancement.com/terms.

Audio Enhancement will invoice equipment at the time of shipment with payment due within terms. Services completed by Audio Enhancement will be invoiced upon substantial completion with payment due within terms.

If there are any questions about this process, please reach out to our Receivables Team – receivables@audioenhancement.com

*****Audio Enhancement will not be responsible for removal of existing equipment and cabling.*****

Quote **58611**

BoM 1

Part#	Product Name	Qty	Unit Price	Total
	Category : Classroom Equipment			
	System : 4 Speaker Optimum System			
CK-4010	Wiring Bundle for CA-30/60/70 Amplifiers	23	\$104.77	\$2,409.71
ST-XD-9060	XD Teacher Box with Teacher Pendant and Student Handheld Microphone	23	\$510.19	\$11,734.37
ST-SP-0211	FS-22 Ceiling Speaker, 1x2 Tile Replacement, Plenum Rated, Set of 4	23	\$381.88	\$8,783.24
NE-0016	WBA-602 Call Button, Emergency Button, Ambient Mic with Access Panel	23	\$110.60	\$2,543.80
AM-3250.P	MS-700 Network Amp with Integrated XD Receiver with Programming	23	\$2,096.64	\$48,222.72
	System : 8 Speaker Optimum System			
AC-0003	50' Speaker Wire Plenum Rated, White	1	\$25.83	\$25.83
CK-4010	Wiring Bundle for CA-30/60/70 Amplifiers	1	\$104.77	\$104.77
ST-XD-9060	XD Teacher Box with Teacher Pendant and Student Handheld Microphone	1	\$510.19	\$510.19
ST-SP-0211	FS-22 Ceiling Speaker, 1x2 Tile Replacement, Plenum Rated, Set of 4	1	\$381.88	\$381.88
ST-SP-0211	FS-22 Ceiling Speaker, 1x2 Tile Replacement, Plenum Rated, Set of 4	1	\$381.88	\$381.88
NE-0016	WBA-602 Call Button, Emergency Button, Ambient Mic with Access Panel	1	\$110.60	\$110.60
AM-3250.P	MS-700 Network Amp with Integrated XD Receiver with Programming	1	\$2,096.64	\$2,096.64
	System : Gym/Cafeteria			
AC-0115	50' Cat6, Plenum Rated, Purple	1	\$37.07	\$37.07
WP-0001	Wall Plate, WPA-701, Ambient Mic with Decora Plate	1	\$67.70	\$67.70
PA-1061.P	Viking E-30-IP VoIP Entry Phone with Programming	1	\$759.26	\$759.26
	System : 2-Way Intercom System with Programming (MS-320)			
AM-3244.P	MS-320 Network Interface for 2-Way Intercom with Programming (Requires PoE+)	1	\$754.95	\$754.95
CK-4011	Wiring Bundle for MS-600 Optimum Amplifier with Integrated XD Receiver	1	\$141.84	\$141.84
ST-SP-0212	FS-22 Ceiling Speaker, 1x2 Tile Replacement, Plenum Rated, Set of 2	1	\$190.94	\$190.94
WP-0002	Wall Plate, WPA-702, Call Button, Emergency Button, Ambient Mic with Decora Plate	1	\$67.70	\$67.70
	Category : EPIC System School Equipment			
	System : 8 Speaker Optimum System			
AC-0002	75' Speaker Wire Plenum Rated, White	1	\$32.57	\$32.57
	System : Gym/Cafeteria			

Part#	Product Name	Qty	Unit Price	Total
AM-1003	EPIC Common Zone Amplifier 1 X 80W 70V, 1U HALF-RACK	1	\$563.85	\$563.85
ST-AM-8003.P	MS-300 Network Interface with Programming (Requires PoE)	1	\$657.33	\$657.33
	System : Hallway			
AM-1012	EPIC Common Zone Amplifier 1 X 300W 70V, 2U	1	\$1,050.00	\$1,050.00
ST-AM-8003.P	MS-300 Network Interface with Programming (Requires PoE)	1	\$657.33	\$657.33
	System : Admin			
AM-1003	EPIC Common Zone Amplifier 1 X 80W 70V, 1U HALF-RACK	1	\$563.85	\$563.85
ST-AM-8003.P	MS-300 Network Interface with Programming (Requires PoE)	1	\$657.33	\$657.33
	System : Exterior Zone			
AM-1003	EPIC Common Zone Amplifier 1 X 80W 70V, 1U HALF-RACK	1	\$563.85	\$563.85
ST-AM-8003.P	MS-300 Network Interface with Programming (Requires PoE)	1	\$657.33	\$657.33
	System : East Hallway			
AM-1003	EPIC Common Zone Amplifier 1 X 80W 70V, 1U HALF-RACK	1	\$563.85	\$563.85
ST-AM-8003.P	MS-300 Network Interface with Programming (Requires PoE)	1	\$657.33	\$657.33
	System : Virtual EPIC Head End System			
PA-0095.P	EPIC Grandstream Enterprise Phone with Programming	1	\$170.42	\$170.42
EP-0020.P	EPIC Kiosk with Programming	1	\$1,755.06	\$1,755.06
EP-0105.P	CLAUDIA, EPIC Front Office Media Player with Programming (Requires AC Power)	1	\$757.80	\$757.80
PA-0045	UPS 425VA 6-Outlet 120V for use with EPIC Kiosk	1	\$111.20	\$111.20
	Miscellaneous			
PA-0191	25/70V Volume Control	3	\$31.45	\$94.35
SP-1022	70V Wall Mount Speaker, White	8	\$103.33	\$826.64
SP-1094	70V Indoor Fixed Angled Horn Speaker and Enclosure	2	\$229.13	\$458.26
SP-1091	70V Outdoor Horn Speaker and Enclosure	5	\$249.60	\$1,248.00
SP-1095	70V 2x2 Tile Replacement Speaker	36	\$175.00	\$6,300.00
	Category : Services			
	System : Virtual EPIC Head End System			
SE-1002	EPIC Custom Map Development Services	1	\$525.00	\$525.00
SE-1047	Virtual Server Programming	1	\$1,700.00	\$1,700.00

Part#	Product Name	Qty	Unit Price	Total
SE-1043	EPIC System Third Party System Integration	1	\$1,050.00	\$1,050.00
SE-1024	Engineering and Design Services	1	\$1,495.00	\$1,495.00
	Category : Software Licensing			
	System : Virtual EPIC Head End System			
EP-0009	EPIC System Platform License	1	\$5,054.40	\$5,054.40
EP-0010	SAFE System License (Requires EP-0009)	1	\$3,994.10	\$3,994.10
EP-0022	EPIC System Intercom Paging & Bells License (Requires EP-0009)	1	\$1,460.16	\$1,460.16
EP-0034	EPIC Phone Integration License	1	\$1,034.80	\$1,034.80
	Category : Training			
	System : Virtual EPIC Head End System			
EP-0035	EPIC Administrator Training	1	\$500.00	\$500.00
EP-0019	EPIC Experience Training	1	\$5,400.00	\$5,400.00

Quote **58611**

Additional BOM Items

Part#	Product Name	Qty	Unit Price	Total
	Category : Classroom Equipment			
PA-0164	Black Surface Mount Box	1	\$162.86	\$162.86
	Category : EPIC System School Equipment			
AC-0004	18/2 Spooled Speaker Wire Plenum Rated Per Foot, White	4000	\$0.71	\$2,840.00
SE-0083.	Install Supply Kit	24	\$65.00	\$1,560.00
	Category : Services			
SE-0002	Installation Labor Per Hour	1	\$86.00	\$86.00
SE-0012	Lift Rental	1	\$550.00	\$550.00
SE-0067	Optional Contingency	64	\$100.00	\$6,400.00
SE-0025	Travel Services	1	\$1,650.00	\$1,650.00
SE-0073	Project Management Services	30	\$120.00	\$3,600.00
SE-1068	Installation of 70V Equipment	54	\$257.00	\$13,878.00
SE-0032	Commissioning Service	31	\$110.00	\$3,410.00
SE-0080	Installation of Kiosk	1	\$172.00	\$172.00
SE-0081	Installation of Wallplate	2	\$86.00	\$172.00
SE-0035	Installation of Audio System	24	\$416.00	\$9,984.00
SE-0037	Installation of 2-Way Intercom System	1	\$453.00	\$453.00
SE-0038	Installation of MS-300 for Common Zone Amplifier	5	\$265.00	\$1,325.00

Audio Enhancement, Inc. is pleased to offer the following warranty.

A standard Five (5) year limited manufacturer's warranty ("Limited Warranty") against malfunction due to manufacturing defects in materials or workmanship on the IR and XD teacher and student microphone, XD receiver (K-SRC14), CA-30, CA-60, GL-300, Hydra II, XDSolo™, BEAM, BEAM Pro, Handheld Microphone Holder, and Ceiling and Wall speakers ("Audio Enhancement Products"). The Limited Warranty applies only if: (1) the Audio Enhancement Products are installed according to manufacturer's instruction provided to Customer and (2) the Audio Enhancement Products are not misused or abused, and there is no evidence of mishandling, neglect, modification, or repair without the approval of Audio Enhancement.

A standard three (3) year limited manufacturer's warranty ("Limited Warranty") against malfunction due to manufacturing defects in materials or workmanship on the EduCam360, EduCam 360-A, EduCam360-B, EduCam360-C, EduCamPTZ, EduCamPTZ-B, MS-1000 Monitoring Station (MS-1000), AVConnect (HDBaseT), SAFE System, EPIC System Server, MS-300, MS-500, and CLAUDIA. The Limited Warranty applies only if (1) the Audio Enhancement product is installed according to manufacturer's instructions and by an Audio Enhancement certified installer and (2) the Audio Enhancement Products are not misused or abused, and there is no evidence of mishandling, neglect, modification, or repair without the approval of Audio Enhancement.

A standard one (1) year limited manufacturer's warranty ("Limited Warranty") against malfunction due to manufacturing defects in materials or workmanship on our General Electronics (including but not limited to: NVRs, Classroom Wall Box, MS-400, Hydra Adapter (SC-12-24VACDC), Wall Plate Accessories (WPA), Alert Notification Button, Mic360™, UPS (Uninterrupted Power Supply)), specialty cables and adapters. EPIC System Console Touchscreen, Server Drives, and EPIC System Console Paging Microphone. The Limited Warranty applies only if (1) the General Electronics is installed according to manufacturer's instructions and by an Audio Enhancement certified installer and (2) the General Electronics has not been misused or abused, and there is no evidence of mishandling, neglect, modification or repair without the approval of the manufacturer.

The EduCam390 camera SD card and 'AA' NiMH and lithium-ion batteries supplied by Audio Enhancement, Inc., carry a 90-day warranty from date of purchase.

The following is not included under this Limited Warranty: (1) Misuse or abuse by the Customer; (2) normal wear and tear; (3) physical damage to Audio Enhancement's Products because of unreasonable use and/or negligence; and (4) damage caused by service or repairs by the customer or a person who is not authorized for such service or repairs by Audio Enhancement.

This Limited Warranty is provided by Audio Enhancement, and it contains the only express warranty provided to Customer by Audio Enhancement. Audio Enhancement does not authorize any other person, including distributors, to give any other warranties on

Audio Enhancement's behalf. The repair or replacement as provided under the express limited warranty is the sole and exclusive remedy of the Customer and Audio Enhancement's sole and exclusive liability hereunder.

Audio Enhancement disclaims any express warranty not provided herein and any implied warranty, guarantee, or representation as to performance, quality and absence of hidden defects, and any remedy for breach of contract, which but for this provision, might arise by implication, operation of law, custom of trade or course of dealing, including implied warranties of merchantability and fitness for a particular purpose. In no event shall Audio Enhancement be liable, whether in contract, tort (including negligence) or otherwise, for damages more than the purchase price of the product giving rise to the damages, or for any direct, indirect, incidental, special, punitive, exemplary, or consequential damages of any kind. Audio Enhancement further disclaims any responsibility for losses, expenses, inconveniences, special, indirect, secondary, or consequential, incidental, and contingent damages whatsoever, including damages arising from ownership or use of Audio Enhancement's products.

Audio Enhancement shall bear no responsibility or obligation with respect to the manner of use of any equipment sold by Audio Enhancement.

Audio Enhancement specifically disclaims and negates any warranty of fitness for a particular purpose of such equipment including, without limitation, any warranty that the use of such equipment for any purpose will comply with applicable laws and regulations or overcome any specific hearing/auditory processing deficit. When returning units for service, use adequate packaging to prevent shipping damage. Shipping damage is not covered under warranty.



Technical Support

Audio Enhancement Technical Support Representatives are available to assist by phone, chat, and email. With offices in West Jordan, Utah; Apopka, Florida; and Alpharetta, Georgia, we offer additional regional resources to ensure our local customers have all the support to meet their needs. Here is our companies technical support information and FAQ's.

Contact Support:

Hours: Monday-Friday 8:00am-7:00pm EST.

Phone: 800.932.3578

Email: Support@AudioEnhancement.com

Chat and RMA: www.AudioEnhancement.com/Support/

Additional Support:

Training Website: www.training.AudioEnhancement.com

YouTube Site: www.youtube.com/user/AudioEnhancementInc

Support Levels:

Level 1 Level 1 support is for basic audio systems. Tickets are created when a phone call is made, RMA is submitted, or an email is sent to support. Level 1 support services include troubleshooting with microphones, batteries, cabling, volume levels, information requests, and basic EPIC troubleshooting and setup.

Level 2 When a higher level of support is required, tickets are escalated to Level 2 support. This type of support includes advanced audio troubleshooting. Enhanced EPIC support including device configuration, SIP integration, LDAP integration, and configuration of VIEWPath and VIEWPath Live.

Level 3 Level 3 support is for final escalations and is handled by Audio Enhancement engineers and developers with 10+ years of experience.

Additional Support Personnel:

Audio Enhancement headquarters is located in West Jordan, Utah with two satellite offices in Apopka, Florida and Alpharetta, Georgia. Between our three offices and field services reps across the country, Audio Enhancement can provide additional onsite support when needed.

Project Information

- **Project Summary ***
NE - Gering Northfield ES EPIC Audio SAFE
- **Opportunity Number**
23649
- **Request design team to design your school? ***
No
- **Will this project be using a Contract? ***
No
- **Will Audio Enhancement be Installing? ***
Yes
- **Does this project utilize Davis Bacon rates or Prevailing Wage?**
No
- **Site Status at Any Point During Implementation ***
None of the above
- **Are there any drawings or specifications we are required to meet for this project? ***
No

This proposed design was finalized by Audio Enhancement. The customer approval of original design was bypassed by Taylor Noyes at 20 Dec, 2023 5:59 PM.

Explanation:

Approved by Nicole Regan via email., Bypassed by Taylor Noyes on 20 Dec, 2023 5:59 PM

Audio Enhancement Solutions Proposal



December 20, 2023

Proposal ID# 114561
SAP Quote# 58609

Prepared For Gering Public Schools



Dear Gering Public Schools,

I want to personally thank you for inviting us to submit a proposal to Gering Public Schools!

When my mother, Claudia Anderson, founded Audio Enhancement over 40 years ago, we never imagined the impact our services would have on education today. Through customer feedback, we have grown from offering classroom audio solutions to providing district-wide communication and safety technology. We have impacted over 4,000 districts, 39,000 schools, and over 1,200,000 classrooms across the world. We are excited for the opportunity to help you!

Our team focuses on hiring employees with a passion to make a difference in education. We look forward to developing a deeper partnership with Gering Public Schools through building friendship and trust during the ongoing stages of your project.

It is our pleasure to submit this proposal to Gering Public Schools. As with all proposals, revisions can be made at any time.

We look forward to your response and are available to answer any questions during the review process.

From all of us here at Audio Enhancement, thank you!

Sincerely yours,



Jeff Anderson

Jeff Anderson
Audio Enhancement, CEO



Making a Difference in Education

For more than forty years, Audio Enhancement has served the schools throughout the United States, providing both classroom audio enhancement systems as well as integration services for classroom technology. Audio Enhancement is headquartered in Salt Lake City Utah and has facilities in Georgia and Florida.

Audio Enhancement was founded in 1978 by Claudia Anderson around the simple idea that “learning begins with hearing.” Having two hearing impaired children; the first Audio Enhancement systems were designed specifically for the hearing impaired. Early in our history, technological advancements made it possible to also provide whole classroom sound systems, benefiting all students. Audio Enhancement has been the innovator and leader in this field.

By 2004, it was clear that classroom audio enhancement systems were a key part of the overall technology landscape in the classroom. Based on our high level of support, outstanding customer service, and training that was provided for the audio systems, several school districts came to us and requested that we expand our product offerings. Based on these requests, we undertook an initiative to increase our capabilities in order to provide a complete integrated technology package for the classroom. These offerings include display devices, control, video/audio playback devices and interactive technologies. By utilizing the principles developed over thirty years of providing classroom audio systems to the schools, we were able to provide both technical integration, teacher in-servicing, training, and professional development to help the schools ensure the success of their technology goals.

Moving the company forward, in 2008, Audio Enhancement was incorporated: Jeff Anderson, President and CEO, Jennifer Crum, CFO, Jeremy Anderson, CAO and Justin Anderson, COO. Today, the Audio Enhancement product line improves student achievement, decreases teacher vocal fatigue and absenteeism, and creates positive student behavior. Audio Enhancement systems also increase focus and attention and supports classroom management.



The Anderson Family



Classroom Audio

A classroom Audio Enhancement system provides teachers with benefits seen in documented sound field system research with the consistency and clarity of the newest classroom technology—XD Audio. Teachers wear an XD Microphone with confidence of zero signal drop-outs. This delivers their voices to each student as clearly as if the teacher were sitting right next to them. With Classroom Audio, you can expect more time on task, fewer behavior issues, less teacher verbal repetition, and better content understanding. These provide an increase in actual instructional time, one thing every teacher can use more of. Clear and equitably distributed audio in the classroom contributes to the overall quality of instruction, targeting gaps in learning.

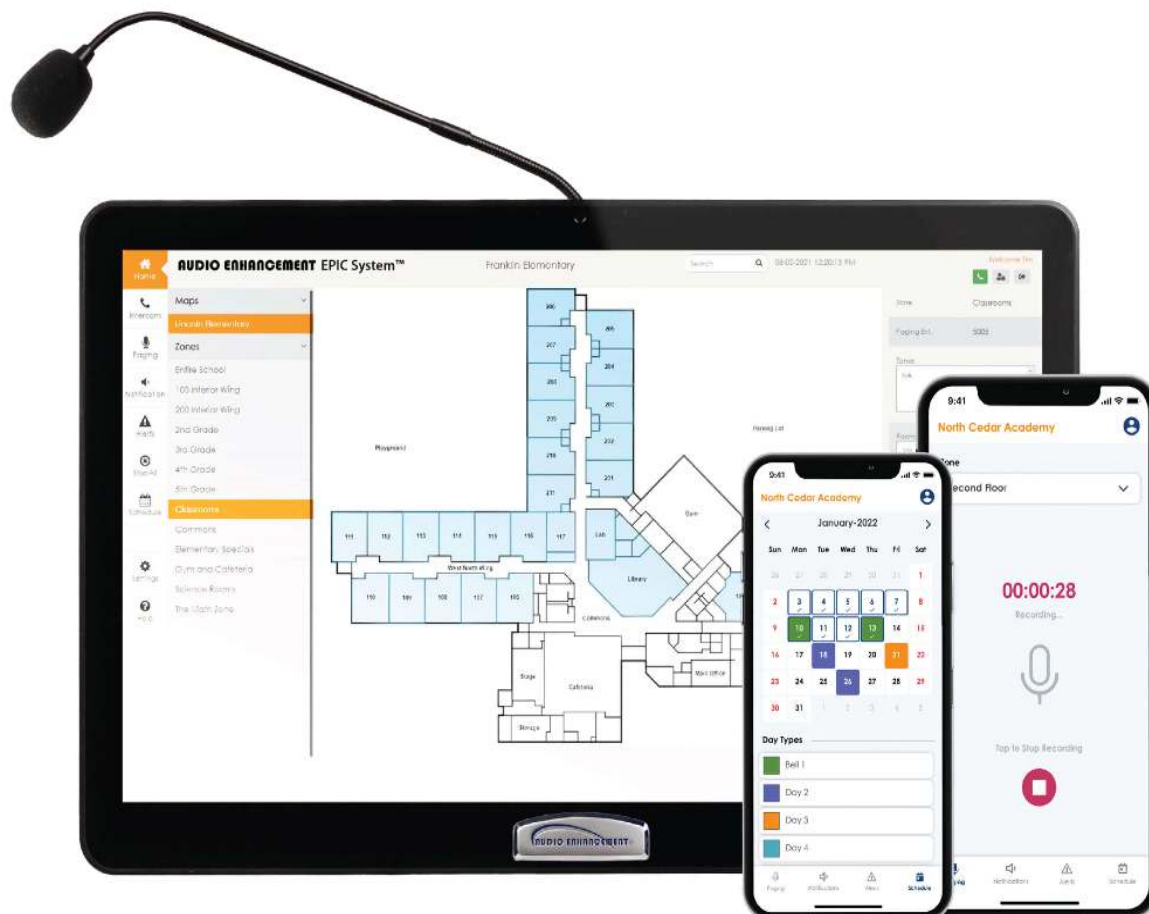

EPIC System

EPIC System allows schools to effectively and efficiently manage and schedule student movement within the school. By customizing bells and announcements on an individual classroom level, schools can eliminate unnecessary distractions to the learning environment, maximizing allocated learning time. EPIC system can be controlled from the Kiosk or the EPIC mobile app. Optional InfoView expands your EPIC System to include customizable classroom clocks, visual emergency notifications, and digital signage around your campus.

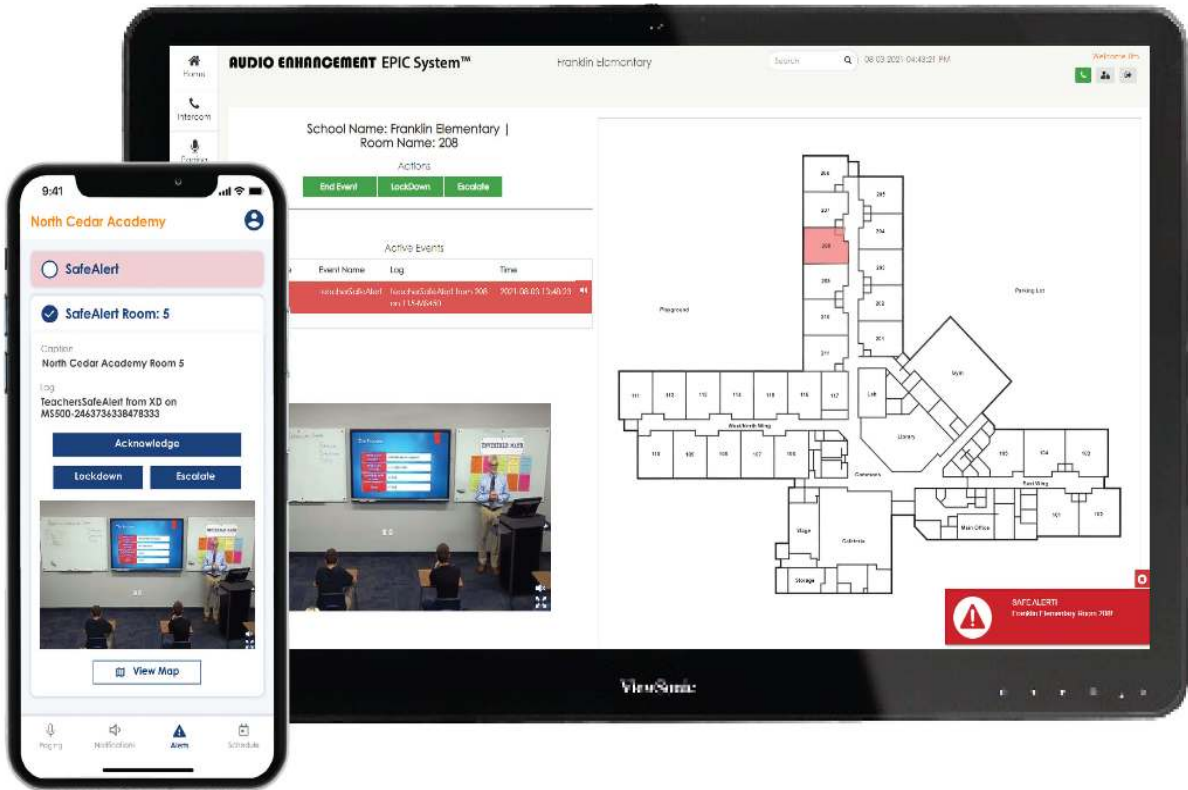

SAFE System

SAFE System™ (Signal Alert For Education) System™ is an alert and notification solution that connects teachers and classrooms to first responders for quick response and communication. The integration of SAFE System with our teacher microphone gives teachers a personal duress button to send alerts instantly from anywhere in the school. Office staff can discreetly acknowledge the alert, letting teachers know that help is on the way. The web-based interface gives administrators the ability to provide direction and maintain situational awareness of the entire campus, even in the most challenging emergency conditions. Give everyone on your campus peace of mind with the reassurance that SAFE is ready when seconds count.

Selected Systems and Products

4 Speaker Optimum System

QTY - 19

COMPATIBILITY



The MS-700 Optimum Amplifier is a fully integrated networked classroom amplifier and wireless microphone receiver. This amplifier has network-based intercom, paging and emergency notification, and provides full-duplex audio. It is easy-to-use, easy-to-install, and has simple user interface software. The entire unit utilizes Power over Ethernet (PoE+). Intercom and paging functionalities[†] are built-in. During emergencies, paging can still be heard, even when the power goes out.

INCLUDED COMPONENTS



Wiring Bundle for CA-30/60/70 Amplifiers



XD Teacher Box with Teacher Pendant and Student Handheld Microphone

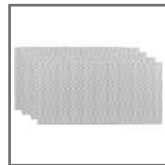

FS-22 Ceiling Speaker, 1x2 Tile Replacement, Plenum Rated, Set of 4



WBA-602 Call Button, Emergency Button, Ambient Mic with Access Panel



MS-700 Network Amp with Integrated XD Receiver with Programming

Full System Product Details

Wiring Bundle for CA-30/60/70 Amplifiers, XD Teacher Box with Teacher Pendant and Student Handheld Microphone, FS-22 Ceiling Speaker, 1x2 Tile Replacement, Plenum Rated, Set of 4, WBA-602 Call Button, Emergency Button, Ambient Mic with Access Panel, MS-700 Network Amp with Integrated XD Receiver with Programming.

2-Way Intercom System

QTY - 02

COMPATIBILITY



The MS-320 is a network interface that has intercom, paging and emergency notification, providing full-duplex audio. It is easy-to-use and easy-to-install. The entire unit is Powered over Ethernet (PoE). Intercom and paging functionalities^{**} are built-in. During emergencies, paging can still be heard, even when the power goes out. This unit can be installed as part of the SAFE (Signal Alert For Education) System[™].

INCLUDED COMPONENTS



MS-320 Network Interface for 2-Way Intercom with Programming (Requires PoE+)



Wiring Bundle for MS-600 Optimum Amplifier with Integrated XD Receiver



FS-22 Ceiling Speaker, 1x2 Tile Replacement, Plenum Rated, Set of 2



Wall Plate, WPA-702, Call Button, Emergency Button, Ambient Mic with Decora Plate

Full System Product Details

MS-320 Network Interface for 2-Way Intercom with Programming (Requires PoE+), Wiring Bundle for MS-600 Optimum Amplifier with Integrated XD Receiver, FS-22 Ceiling Speaker, 1x2 Tile Replacement, Plenum Rated, Set of 2, Wall Plate, WPA-702, Call Button, Emergency Button, Ambient Mic with Decora Plate.

Hallway Zone

QTY - 01

COMPATIBILITY



MS-300 Network Interface with 7' Cat6 & 3.5 to RCA Cables (KIT) used for paging. Also includes a variety of 70v Amplifier for areas with multiple 70v speakers like hallways, gyms, internal/external horns etc. Add optional wall plate for 2 way calling functionality.

INCLUDED COMPONENTS



EPIC Common Zone Amplifier 1 X 80W 70V, 1U HALF-RACK



MS-300 Network Interface with Programming (Requires PoE)

Full System Product Details

EPIC Common Zone Amplifier 1 X 80W 70V, 1U HALF-RACK, MS-300 Network Interface with Programming (Requires PoE).

Gym Zone

QTY - 01

COMPATIBILITY



MS-300 Network Interface with 7' Cat6 & 3.5 to RCA Cables (KIT) used for paging. Also includes a variety of 70v Amplifier for areas with multiple 70v speakers like hallways, gyms, internal/external horns etc. Add optional wall plate for 2 way calling functionality.

INCLUDED COMPONENTS



EPIC Common Zone Amplifier 1 X 80W 70V, 1U HALF-RACK



MS-300 Network Interface with Programming (Requires PoE)



50' Cat6, Plenum Rated, Purple



Wall Plate, WPA-701, Ambient Mic with Decora Plate



Viking E-30-IP VoIP Entry Phone with Programming

Full System Product Details

EPIC Common Zone Amplifier 1 X 80W 70V, 1U HALF-RACK, MS-300 Network Interface with Programming (Requires PoE), 50' Cat6, Plenum Rated, Purple, Wall Plate, WPA-701, Ambient Mic with Decora Plate, Viking E-30-IP VoIP Entry Phone with Programming,

Exterior Zone

QTY - 01

COMPATIBILITY



MS-300 Network Interface with 7' Cat6 & 3.5 to RCA Cables (KIT) used for paging. Also includes a variety of 70v Amplifier for areas with multiple 70v speakers like hallways, gyms, internal/external horns etc. Add optional wall plate for 2 way calling functionality.

INCLUDED COMPONENTS



EPIC Common Zone Amplifier 1 X 80W 70V, 1U HALF-RACK



MS-300 Network Interface with Programming (Requires PoE)

Full System Product Details

EPIC Common Zone Amplifier 1 X 80W 70V, 1U HALF-RACK, MS-300 Network Interface with Programming (Requires PoE).

Virtual EPIC Head End System

QTY - 01

COMPATIBILITY



Everything you need in order for an EPIC System central head-end.

INCLUDED COMPONENTS



EPIC Grandstream Enterprise Phone with Programming



EPIC Kiosk with Programming



CLAUDIA, EPIC Front Office Media Player with Programming (Requires AC Power)



EPIC System Platform License



SAFE System License (Requires EP-0009)



EPIC System Intercom Paging & Bells License (Requires EP-0009)

Full System Product Details

EPIC Grandstream Enterprise Phone with Programming, EPIC Kiosk with Programming, CLAUDIA, EPIC Front Office Media Player with Programming (Requires AC Power), EPIC System Platform License, SAFE System License (Requires EP-0009), EPIC System Intercom Paging & Bells License (Requires EP-0009),

Selected Systems and Products

25/70V Volume Control

QTY - 01



25 Watt 70V/100V/25V Rotary Volume Control white wall plate

70V Wall Mount Speaker, White

QTY - 05



70V Wall Mount Speaker in white.

70V Indoor Fixed Angled Horn Speaker and Enclosure

QTY - 02



This kit includes one 70 Volt H16 SVP angled front speaker and one SE2WVP slanted enclosure.

70V Outdoor Horn Speaker and Enclosure

QTY - 04



The SYSTEM 6VPS is a complete, vandal resistant horn assembly featuring a double re-entrant, compression horn with an integrated 16W, 25/70V, multi-tap transformer that is mounted on a vandal resistant, stainless steel baffle. It also includes a square, heavy gauge stainless steel, surface mount enclosure.

70V 2x2 Tile Replacement Speaker

QTY - 17



SYSTEM 19 is a complete, UL Listed, 2-way, shallow depth, lightweight, 2' x 2' lay-in ceiling tile replacement loudspeaker system consisting of an 6 1/2" O.D. woofer, 1" dome tweeter, and a 20W, 70V, rotary select transformer with an 8 Ohm position. The molded fiber enclosure is 1,283 CID. The SYSTEM 19 has a powder coated steel baffle with standard perforation and four (4) seismic tie-off points.

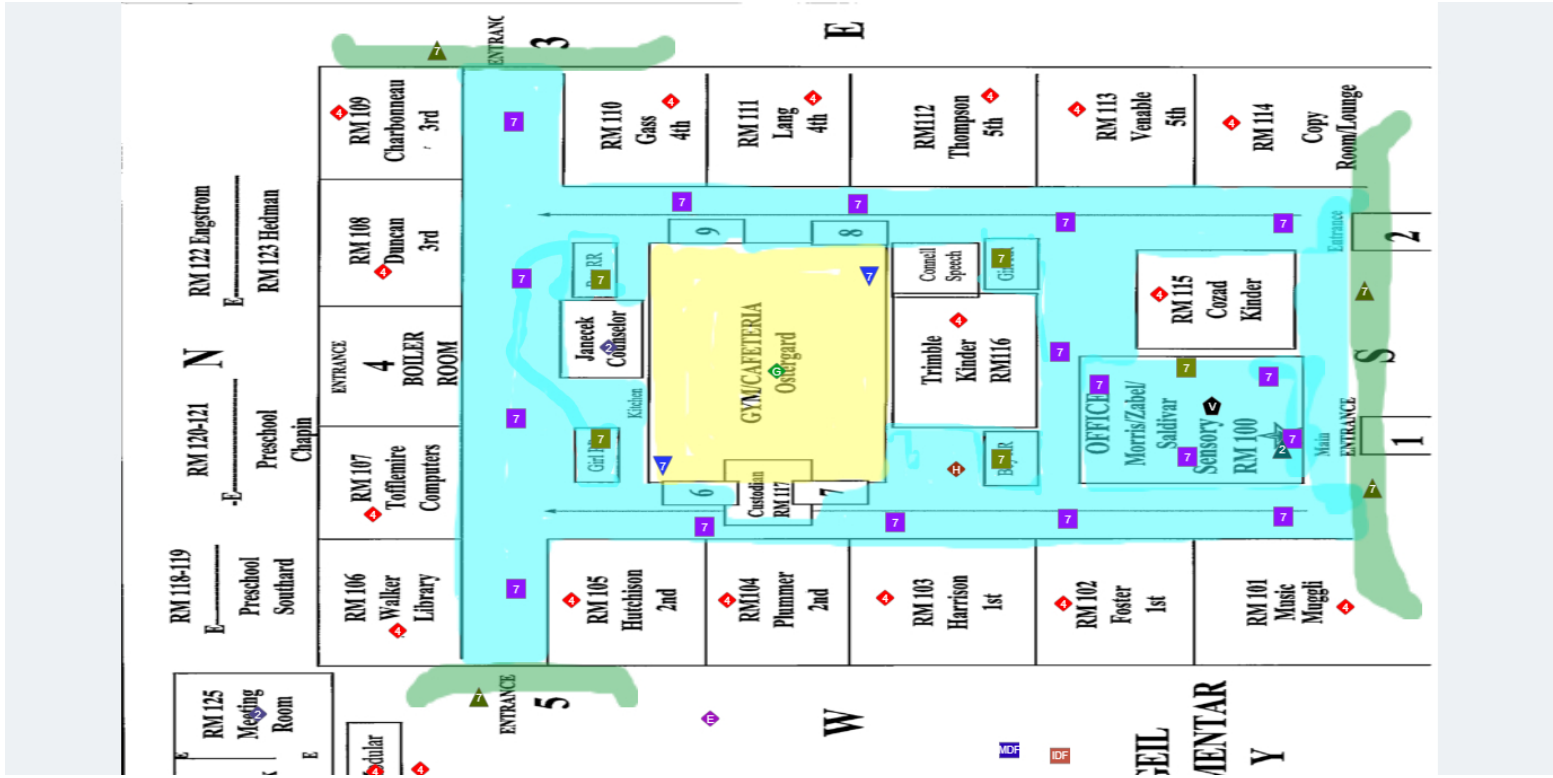

Pricing Proposal

Pricing Valid for 90 Days - March 19, 2024



Quote **58609**

Gering Public Schools - NE - Gering Geil ES EPIC

Classroom Equipment	\$64,215.27
EPIC System School Equipment	\$15,127.78
Services	\$35,394.00
Software Licensing	\$11,543.46
Training	\$5,900.00
<hr/>	
	Discount (\$27,017.71)
	Taxes \$0.00
	Shipping \$2,679.80
<hr/>	
Gering Public Schools Price	\$107,842.60

By sending in a Purchase Order in response to this proposal, the customer is agreeing to the Audio Enhancement terms and conditions which can be viewed at Audioenhancement.com/terms.

Audio Enhancement will invoice equipment at the time of shipment with payment due within terms. Services completed by Audio Enhancement will be invoiced upon substantial completion with payment due within terms.

If there are any questions about this process, please reach out to our Receivables Team – receivables@audioenhancement.com

*****Audio Enhancement will not be responsible for removal of existing equipment and cabling.*****

Quote **58609**

BoM 1

Part#	Product Name	Qty	Unit Price	Total
	Category : Classroom Equipment			
	System : 4 Speaker Optimum System			
CK-4010	Wiring Bundle for CA-30/60/70 Amplifiers	19	\$104.77	\$1,990.63
ST-XD-9060	XD Teacher Box with Teacher Pendant and Student Handheld Microphone	19	\$510.19	\$9,693.61
ST-SP-0211	FS-22 Ceiling Speaker, 1x2 Tile Replacement, Plenum Rated, Set of 4	19	\$381.88	\$7,255.72
NE-0016	WBA-602 Call Button, Emergency Button, Ambient Mic with Access Panel	19	\$110.60	\$2,101.40
AM-3250.P	MS-700 Network Amp with Integrated XD Receiver with Programming	19	\$2,096.64	\$39,836.16
	System : 2-Way Intercom System			
AM-3244.P	MS-320 Network Interface for 2-Way Intercom with Programming (Requires PoE+)	2	\$754.95	\$1,509.90
CK-4011	Wiring Bundle for MS-600 Optimum Amplifier with Integrated XD Receiver	2	\$141.84	\$283.68
ST-SP-0212	FS-22 Ceiling Speaker, 1x2 Tile Replacement, Plenum Rated, Set of 2	2	\$190.94	\$381.88
WP-0002	Wall Plate, WPA-702, Call Button, Emergency Button, Ambient Mic with Decora Plate	2	\$67.70	\$135.40
	System : Gym Zone			
AC-0115	50' Cat6, Plenum Rated, Purple	1	\$37.07	\$37.07
WP-0001	Wall Plate, WPA-701, Ambient Mic with Decora Plate	1	\$67.70	\$67.70
PA-1061.P	Viking E-30-IP VoIP Entry Phone with Programming	1	\$759.26	\$759.26
	Category : EPIC System School Equipment			
	System : Hallway Zone			
AM-1003	EPIC Common Zone Amplifier 1 X 80W 70V, 1U HALF-RACK	1	\$563.85	\$563.85
ST-AM-8003.P	MS-300 Network Interface with Programming (Requires PoE)	1	\$657.33	\$657.33
	System : Gym Zone			
AM-1003	EPIC Common Zone Amplifier 1 X 80W 70V, 1U HALF-RACK	1	\$563.85	\$563.85
ST-AM-8003.P	MS-300 Network Interface with Programming (Requires PoE)	1	\$657.33	\$657.33
	System : Exterior Zone			
AM-1003	EPIC Common Zone Amplifier 1 X 80W 70V, 1U HALF-RACK	1	\$563.85	\$563.85
ST-AM-8003.P	MS-300 Network Interface with Programming (Requires PoE)	1	\$657.33	\$657.33
	System : Virtual EPIC Head End System			
PA-0095.P	EPIC Grandstream Enterprise Phone with Programming	1	\$170.42	\$170.42

Part#	Product Name	Qty	Unit Price	Total
EP-0020.P	EPIC Kiosk with Programming	1	\$1,755.06	\$1,755.06
EP-0105.P	CLAUDIA, EPIC Front Office Media Player with Programming (Requires AC Power)	1	\$757.80	\$757.80
PA-0045	UPS 425VA 6-Outlet 120V for use with EPIC Kiosk	1	\$111.20	\$111.20
	Miscellaneous			
PA-0191	25/70V Volume Control	1	\$31.45	\$31.45
SP-1022	70V Wall Mount Speaker, White	5	\$103.33	\$516.65
SP-1094	70V Indoor Fixed Angled Horn Speaker and Enclosure	2	\$229.13	\$458.26
SP-1091	70V Outdoor Horn Speaker and Enclosure	4	\$249.60	\$998.40
SP-1095	70V 2x2 Tile Replacement Speaker	17	\$175.00	\$2,975.00
	Category : Services			
	System : Virtual EPIC Head End System			
SE-1002	EPIC Custom Map Development Services	1	\$525.00	\$525.00
SE-1047	Virtual Server Programming	1	\$1,700.00	\$1,700.00
SE-1043	EPIC System Third Party System Integration	1	\$1,050.00	\$1,050.00
SE-1024	Engineering and Design Services	1	\$1,495.00	\$1,495.00
	Category : Software Licensing			
	System : Virtual EPIC Head End System			
EP-0009	EPIC System Platform License	1	\$5,054.40	\$5,054.40
EP-0010	SAFE System License (Requires EP-0009)	1	\$3,994.10	\$3,994.10
EP-0022	EPIC System Intercom Paging & Bells License (Requires EP-0009)	1	\$1,460.16	\$1,460.16
EP-0034	EPIC Phone Integration License	1	\$1,034.80	\$1,034.80
	Category : Training			
	System : Virtual EPIC Head End System			
EP-0035	EPIC Administrator Training	1	\$500.00	\$500.00
EP-0019	EPIC Experience Training	1	\$5,400.00	\$5,400.00

Quote **58609**

Additional BOM Items

Part#	Product Name	Qty	Unit Price	Total
	Category : Classroom Equipment			
PA-0164	Black Surface Mount Box	1	\$162.86	\$162.86
	Category : EPIC System School Equipment			
AC-0004	18/2 Spooled Speaker Wire Plenum Rated Per Foot, White	3000	\$0.71	\$2,130.00
SE-0083.	Install Supply Kit	24	\$65.00	\$1,560.00
	Category : Services			
SE-0002	Installation Labor Per Hour	1	\$86.00	\$86.00
SE-0012	Lift Rental	1	\$550.00	\$550.00
SE-0067	Optional Contingency	51	\$100.00	\$5,100.00
SE-0025	Travel Services	1	\$1,650.00	\$1,650.00
SE-0073	Project Management Services	25	\$120.00	\$3,000.00
SE-1068	Installation of 70V Equipment	29	\$257.00	\$7,453.00
SE-0032	Commissioning Service	25	\$110.00	\$2,750.00
SE-0080	Installation of Kiosk	1	\$172.00	\$172.00
SE-0081	Installation of Wallplate	3	\$86.00	\$258.00
SE-0035	Installation of Audio System	19	\$416.00	\$7,904.00
SE-0037	Installation of 2-Way Intercom System	2	\$453.00	\$906.00
SE-0038	Installation of MS-300 for Common Zone Amplifier	3	\$265.00	\$795.00



Product Spec Sheets

Specifications

Power Output	40W/80W/120W
Output Channels	1
Input Sensitivity	1.4Vrms for 8-ohms
Phantom Power	27VDC
AC Line Voltage	100 - 240V, 50/60 Hz
Input Impedance	20K ohms/50K ohms
Dimensions	1.7" x 8.6" x 11.9" (43.3mm x 218.5mm x 303.4mm)
Included Accessories	Rack mounting kit



GXP2130 v2

A flexible Enterprise IP Phone

The GXP2130 v2 is a standard enterprise-grade IP phone that features up to 3 lines, 4 XML programmable soft keys, 8 programmable BLF extension keys, dual Gigabit network ports and 4-way voice conferencing. This Enterprise IP Phone comes equipped with Bluetooth, Electronic Hook Switch (EHS) support for Plantronics headsets to allow for flexibility. Ideal for SMBs, enterprises and SOHOs, the GXP2130 v2 is the perfect choice for users looking for a high quality, feature rich IP phone with advanced functionality that is simple to use.



3 lines, with up to 3 SIP accounts, 3 dual-colored line keys



Dual-switched auto-sensing 10/100/1000mbps network ports



Includes 8 dual-colored BLF/speed dial keys



Built-in Bluetooth for syncing headsets and mobile devices for contact books, calendars & call transferring



HD audio to maximize audio quality and clarity, full-duplex speakerphone



Built-in PoE to power the device and give it a network connection



Electronic Hook Switch (EHS) support for Plantronics headsets



Automated provisioning options include TR-069 and XML config files



TLS and SRTP security encryption technology to protect calls and accounts



4-way audio conferencing for easy conference calls

Protocols/Standards	SIP RFC3261, TCP/IP/UDP, RTP/RTCP, HTTP/HTTPS, ARP, ICMP, DNS (A record, SRV, NAPTR), DHCP, PPPoE, TELNET, TFTP, NTP, STUN, SIMPLE, LLDP, LDAP, TR-069, 802.1x, TLS, SRTP, IPv6
Network Interfaces	Dual switched auto-sensing 10/100/1000 Mbps Gigabit Ethernet ports with integrated PoE
Graphic Display	2.8 inch (320x240) TFT color LCD
Bluetooth	Yes, Bluetooth V2.1
Feature Keys	3 line keys with up to 3 SIP accounts, 8 speed-dial/BLF extension keys with dual-color LED, 4 programmable context sensitive softkeys, 5 navigation/menu keys, 11 dedicated function keys for: MESSAGE (with LED indicator), PHONEBOOK, TRANSFER, CONFERENCE, HOLD, HEADSET, MUTE, SEND/REDIAL, SPEAKERPHONE, VOL+, VOL-
Voice Codexs	Support for G.729A/B, G.711 μ /a-law, G.726, G.722 (wide-band), in-band and out-of-band DTMF (in audio, RFC2833, SIP INFO)
Auxiliary Ports	RJ9 headset jack (allowing EHS with Plantronics headsets), USB
Telephony Features	Hold, transfer, forward, 4-way audio conference, call park, call pickup, shared-call-appearance (SCA)/bridged-line-appearance (BLA), downloadable phonebook (XML, LDAP, up to 2000 items), call waiting, call log (up to 500 records), customization of screen, off-hook auto dial, auto answer, click-to-dial, flexible dial plan, hot desking, personalized music ringtones and music on hold, server redundancy and fail-over
Sample Applications	Weather, currency, news, XML
HD Audio	Yes, both on handset and speakerphone
Base Stand/Wall Mountable	Yes, allow 2 angle positions
QoS	Layer 2 (808.1Q, 802.1p) and Layer 3 (ToS, DiffServ, MPLS) QoS
Security	User and administrator level passwords, MD5 and MD5-sess based authentication, AES based secure configuration file, SRTP, TLS, 802.1x media access control
Multi-language	English, Arabic, Chinese, Croatian, Czech, Dutch, German, French, Hebrew, Hungarian, Italian, Japanese, Korean, Polish, Portuguese, Russian, Slovenia, Spanish, Turkish
Upgrade/Provisioning	Firmware upgrade via TFTP/HTTP/HTTPS, mass provisioning using TR-069 or encrypted XML configuration file
Power & Green Energy Efficiency	Universal power adapter included: Input: 100-240VAC; Output: +12VDC, 0.5A (6W) Integrated PoE (Power-over-Ethernet) 802.3af, Class 2
Physical	Dimension: 193mm (W) x 211mm (L) x 85mm (H) Unit weight: 0.81kg; Package weight: 1.44kg
Temperature and Humidity	0 ~ 40°C (32 ~ 104°F), 10 ~ 90% (non-condensing)
Package Content	GXP2130 phone, handset with cord, base stand, universal power supply, network cable, Quick Start Guide
Compliance	FCC Part 15 ClassB, EN55022 ClassB, EN61000-3-2, EN61000-3-3, EN55024, EN60950-1, EN62479 RCM: AS/ACIF S004; AS/NZS CISPR22/24; AS/NZS 60950

Classroom CLAUDIA



Front

Front Office CLAUDIA



Front

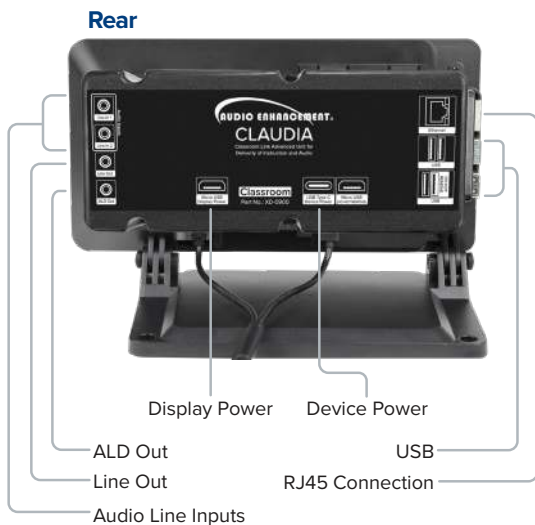

Rear



Rear

CLAUDIA in your Classroom

CLAUDIA provides connectivity and control of the local sound system from an easy to use touchscreen interface right at the teacher's desk. The teacher can connect their computer through the integrated audio input or a device such as their phone through the advanced Bluetooth® Link technology. Additionally, it provides simple integration for use with teleconference services such as Zoom, Google Meets™, and other platforms used for remote learning. Optional features such as SAFE (Signal Alert For Education) System® alerts and VIEWpath® (Video Interactive Education Window) recordings can be activated directly from the 7" touchscreen interface.

CLAUDIA in your Front Office

CLAUDIA in your front office provides an easy interface for streaming music to designated parts of your campus through EPIC System. CLAUDIA will allow music to be played from a local device connected directly, or through a device using the advanced Bluetooth® Link technology. CLAUDIA will also store 200+ songs directly on the device which can be played directly from the 7" touchscreen interface.



Features

- Wireless connectivity to your installed XD Classroom Audio System provides 2-way audio between CLAUDIA and the installed XD Classroom Audio System
- Connect a Bluetooth® device to any Audio Enhancement XD Classroom Audio System through CLAUDIA
- Audio sources such as the teacher's computer, large front of classroom display, or tablet device can be integrated wirelessly between CLAUDIA and the installed XD Classroom Audio System
- 7" Touchscreen display provides for an easy user interface to manage all functions of CLAUDIA
- Managed Bluetooth®: through the web interface, the broadcast name of the CLAUDIA system can be customized to more easily manage to which unit a teacher's device is connected
- Multiple Inputs/Outputs: CLAUDIA provides 2 line level inputs and outputs ensuring that both educational functions and assistive listening applications can be accommodated at the same time

CLAUDIA Specifications*

Power Supply	USB-C Power Supply (Included) 5.1 Volt 3.5 Amp 5ft Power Cable (18 AWG) UL Listed
Touchscreen	7" Capacitive touch display Resolution: 800 x 480 Full Color Display Size: <ul style="list-style-type: none"> • Physical Screen Size: 4.33 (H) x 7.63 (W) x 0.78 (D) in. (110 x 194 x 20 mm) • Viewable Screen Size: 3.38 (H) x 6.10 (W) (86 x 155 mm)
System Specifications	
Processor	Broadcom BCM2711, quad-core Cortex-A72 (ARM v8) 64-bit SoC @ 1.5GHz
Memory	2GB
Connectivity	2.4 GHz and 5.0 GHz IEEE 802.11b/g/n/ac wireless Bluetooth® 5.0 Gigabit Ethernet 2 x USB 3.0 ports 2 x USB 2.0 ports
Environment	Operating temperature 32–120°F (0–50°C)
Audio Input	2 X 3.5mm Line Level Inputs with independent volume control Bluetooth® Audio
Audio Output	2 x 3.5mm Line Level Outputs with independent volume control
Wireless Transceiver	XD Technology 1.9 GHz DECT Based Wireless Transceiver (Classroom version only)
Temperature/Humidity	Storage: -40 to 158°F (-40 to +70°C) / 10-90% non-condensing Operating: -32-122°F (0 to +50°C) / 10-90%
Weight	1.5 lbs (0.68 kg)
Dimensions	5.50 (H) x 8.75 (W) x 4.125 (D) in. (Fully Upright) (139.7 x 222.25 x 104.78 mm)

* All specifications subject to change.



Share:



BE425M

Average Customer Review 5

36 of 36 (100%) reviewers would recommend this product to a friend.

[Read all reviews](#) | [Write a review](#)

Share this Product:



Description: Battery Backup & Surge Protector for Electronics and Computers

Includes : User Manual

Product Overview

Technical Specifications

Documentation

Options

Ratings & Reviews

Output

[Print Technical Specification](#)

Output power capacity	255Watts / 425VA
Max Configurable Power (Watts)	255Watts / 425VA
Nominal Output Voltage	120V
Output Frequency (sync to mains)	50/60Hz +/- 3 Hz
Topology	Standby
Waveform type	Square wave
Output Connections (4) NEMA 5-15R (Battery Backup) (2) NEMA 5-15R (selector_surgetitle)	
Transfer Time	6ms typical : 10ms maximum

Input

Nominal Input Voltage	120V
Input frequency	50/60 Hz +/- 3 Hz (auto sensing)
Input Connections	NEMA 5-15P
Cord Length	5ft (1.52meters)
Input voltage range for main operations	88 - 139V
Number of Power Cords	1
Maximum Input Current	5.0A

Batteries & Runtime

Battery type	Maintenance-free sealed Lead-Acid battery with suspended electrolyte : leakproof	
Typical recharge time	8hour(s)	
Expected Battery Life (years)	3 - 5	
Runtime	View Runtime Graph	View Runtime Chart
Efficiency	View Efficiency Graph	

Communications & Management

Control panel	LED Status display with On Line : On Battery
Audible Alarm	Alarm when on battery : distinctive low battery alarm

Surge Protection and Filtering

Surge energy rating	180Joules
---------------------	-----------

Physical

Maximum Height	5.52inches (140mm , 14.02CM)
Maximum Width	9.98inches (253mm , 25.35CM)
Maximum Depth	4.13inches (105mm , 10.5CM)
Net Weight	5.73lbs. (2.6KG)
Shipping weight	6.61lbs. (3.0KG)
Shipping Height	8.66inches (220mm , 22.0CM)

Shipping Width	12.4inches (315mm , 31.5CM)
Shipping Depth	5.51inches (140mm , 14.0CM)
Color	Black
Master Carton Units	2.0
Master Carton Weight	14.33lbs. (6.5)
Units per Pallet	96.0
SCC Codes	1073130432934 0

Environmental

Operating Temperature	32 - 104 °F (0 - 40 °C)
Operating Relative Humidity	0 - 95 %
Operating Elevation	0-10000ft (0-3000meters)
Storage Temperature	-20 - 50 °C
Storage Relative Humidity	0 - 95 %
Storage Elevation	0-50000ft (0-15000meters)
Audible noise at 1 meter from surface of unit	40.0dBA

Conformance

Approvals	California (CEC) Battery Charger, cTUVus, ENERGY STAR V1.0 (USA), FCC Part 15 Class B
Equipment protection policy	Lifetime : \$75000
Standard warranty	3 years repair or replace

Sustainable Offer Status

RoHS	Compliant
REACH	REACH: Contains No SVHCs



Audio Enhancement's

Upcoming EPIC Experience Training

EPIC Experience training is designed to help school districts get the most out of their EPIC System's intercom, paging, bells and notifications capabilities, back-end administrative event management, SAFE System, and VIEWpath. Participants will learn about device installation, programming, setup, maintenance, and troubleshooting.

Only \$5,400 per attendee: Flights, Lodging, transportation, and meals are included in cost.

EPIC Experience Schedule

Monday	Travel Day
Tuesday	Classroom Audio System devices and connections, EPIC System devices and connections, and labs.
Wednesday	Network and configuration, EPIC Maps and Bells, labs, EPIC roles and permissions, and backups.
Thursday	Notifications, EPIC Events and logs, SAFE alerts, AND Devices & strobes, VIEWpath devices and software, troubleshooting, labs, and resources.
Friday	Travel Day



Side View



Front View

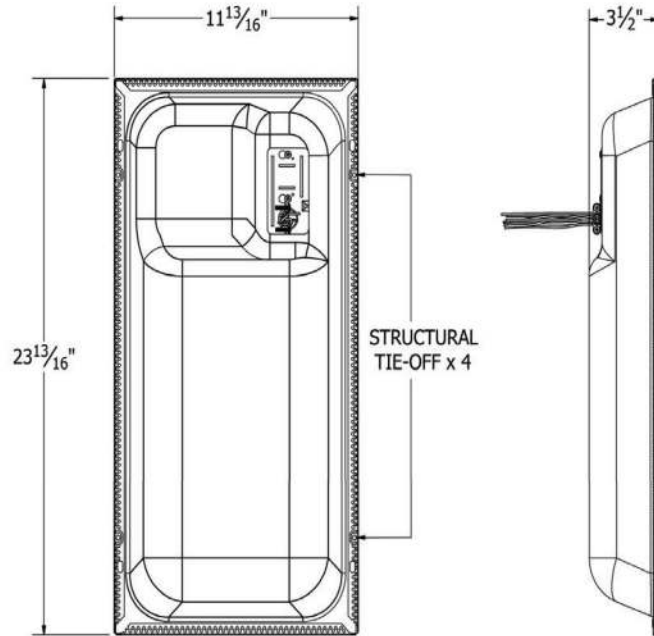
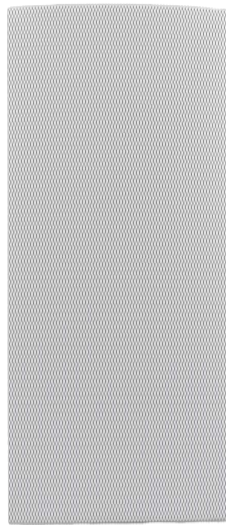

Back View



Tie-Off Tabs

Wiring Access

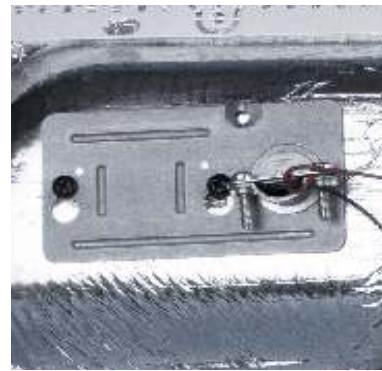

The **FS-22 Flat Panel Speaker** is a custom, fully assembled speaker. Enjoy crystal-clear audio in schools and district buildings. This speaker is designed to be a ceiling tile replacement speaker and fits into a standard grid ceiling. A replacement 24", "T" rail is included, allowing the installer to make one simple cut across a tile to create the 1-foot opening for the speaker. Includes four (4) secure tie-off tabs for additional security. Meets UL2043 criteria for plenum installation.



Speaker Specifications

Frequency Response	70 Hz - 15 kHz (-10 dB) 100 Hz - 14 kHz +/-2 dB
Power Handling	50 W continuous pink noise
Sensitivity	88 dB (1W/1M)
Impedance	8 Ohm nominal
Mounting	Lay in, four tie-off tabs for additional mounting integrity (1) 24", "T" rail included
Plenum Rated Back Can	Speaker back can meets UL2043 criteria for plenum installation
Speaker Wire Terminals	Speaker wires
Weight	4.6 lbs. (1.2 kg)
Dimensions	Height 24 in. (609.6 mm) Width 12 in. (304.8 mm) Depth 3.75 in. (95.25 mm)



Back can is RoHS and UL compliant.



Audio Enhancement, Inc. is pleased to offer the following warranty.

A standard Five (5) year limited manufacturer's warranty ("Limited Warranty") against malfunction due to manufacturing defects in materials or workmanship on the IR and XD teacher and student microphone, XD receiver (K-SRC14), CA-30, CA-60, GL-300, Hydra II, XDSolo™, BEAM, BEAM Pro, Handheld Microphone Holder, and Ceiling and Wall speakers ("Audio Enhancement Products"). The Limited Warranty applies only if: (1) the Audio Enhancement Products are installed according to manufacturer's instruction provided to Customer and (2) the Audio Enhancement Products are not misused or abused, and there is no evidence of mishandling, neglect, modification, or repair without the approval of Audio Enhancement.

A standard three (3) year limited manufacturer's warranty ("Limited Warranty") against malfunction due to manufacturing defects in materials or workmanship on the EduCam360, EduCam 360-A, EduCam360-B, EduCam360-C, EduCamPTZ, EduCamPTZ-B, MS-1000 Monitoring Station (MS-1000), AVConnect (HDBaseT), SAFE System, EPIC System Server, MS-300, MS-500, and CLAUDIA. The Limited Warranty applies only if (1) the Audio Enhancement product is installed according to manufacturer's instructions and by an Audio Enhancement certified installer and (2) the Audio Enhancement Products are not misused or abused, and there is no evidence of mishandling, neglect, modification, or repair without the approval of Audio Enhancement.

A standard one (1) year limited manufacturer's warranty ("Limited Warranty") against malfunction due to manufacturing defects in materials or workmanship on our General Electronics (including but not limited to: NVRs, Classroom Wall Box, MS-400, Hydra Adapter (SC-12-24VACDC), Wall Plate Accessories (WPA), Alert Notification Button, Mic360™, UPS (Uninterrupted Power Supply)), specialty cables and adapters. EPIC System Console Touchscreen, Server Drives, and EPIC System Console Paging Microphone. The Limited Warranty applies only if (1) the General Electronics is installed according to manufacturer's instructions and by an Audio Enhancement certified installer and (2) the General Electronics has not been misused or abused, and there is no evidence of mishandling, neglect, modification or repair without the approval of the manufacturer.

The EduCam390 camera SD card and 'AA' NiMH and lithium-ion batteries supplied by Audio Enhancement, Inc., carry a 90-day warranty from date of purchase.

The following is not included under this Limited Warranty: (1) Misuse or abuse by the Customer; (2) normal wear and tear; (3) physical damage to Audio Enhancement's Products because of unreasonable use and/or negligence; and (4) damage caused by service or repairs by the customer or a person who is not authorized for such service or repairs by Audio Enhancement.

This Limited Warranty is provided by Audio Enhancement, and it contains the only express warranty provided to Customer by Audio Enhancement. Audio Enhancement does not authorize any other person, including distributors, to give any other warranties on

Audio Enhancement's behalf. The repair or replacement as provided under the express limited warranty is the sole and exclusive remedy of the Customer and Audio Enhancement's sole and exclusive liability hereunder.

Audio Enhancement disclaims any express warranty not provided herein and any implied warranty, guarantee, or representation as to performance, quality and absence of hidden defects, and any remedy for breach of contract, which but for this provision, might arise by implication, operation of law, custom of trade or course of dealing, including implied warranties of merchantability and fitness for a particular purpose. In no event shall Audio Enhancement be liable, whether in contract, tort (including negligence) or otherwise, for damages more than the purchase price of the product giving rise to the damages, or for any direct, indirect, incidental, special, punitive, exemplary, or consequential damages of any kind. Audio Enhancement further disclaims any responsibility for losses, expenses, inconveniences, special, indirect, secondary, or consequential, incidental, and contingent damages whatsoever, including damages arising from ownership or use of Audio Enhancement's products.

Audio Enhancement shall bear no responsibility or obligation with respect to the manner of use of any equipment sold by Audio Enhancement.

Audio Enhancement specifically disclaims and negates any warranty of fitness for a particular purpose of such equipment including, without limitation, any warranty that the use of such equipment for any purpose will comply with applicable laws and regulations or overcome any specific hearing/auditory processing deficit. When returning units for service, use adequate packaging to prevent shipping damage. Shipping damage is not covered under warranty.



Technical Support

Audio Enhancement Technical Support Representatives are available to assist by phone, chat, and email. With offices in West Jordan, Utah; Apopka, Florida; and Alpharetta, Georgia, we offer additional regional resources to ensure our local customers have all the support to meet their needs. Here is our companies technical support information and FAQ's.

Contact Support:

Hours: Monday-Friday 8:00am-7:00pm EST.

Phone: 800.932.3578

Email: Support@AudioEnhancement.com

Chat and RMA: www.AudioEnhancement.com/Support/

Additional Support:

Training Website: www.training.AudioEnhancement.com

YouTube Site: www.youtube.com/user/AudioEnhancementInc

Support Levels:

Level 1 Level 1 support is for basic audio systems. Tickets are created when a phone call is made, RMA is submitted, or an email is sent to support. Level 1 support services include troubleshooting with microphones, batteries, cabling, volume levels, information requests, and basic EPIC troubleshooting and setup.

Level 2 When a higher level of support is required, tickets are escalated to Level 2 support. This type of support includes advanced audio troubleshooting. Enhanced EPIC support including device configuration, SIP integration, LDAP integration, and configuration of VIEWPath and VIEWPath Live.

Level 3 Level 3 support is for final escalations and is handled by Audio Enhancement engineers and developers with 10+ years of experience.

Additional Support Personnel:

Audio Enhancement headquarters is located in West Jordan, Utah with two satellite offices in Apopka, Florida and Alpharetta, Georgia. Between our three offices and field services reps across the country, Audio Enhancement can provide additional onsite support when needed.

Project Information

- **Project Summary ***
NE - Gering Geil ES EPIC Audio SAFE
- **Opportunity Number**
22857
- **Request design team to design your school? ***
No
- **Will this project be using a Contract? ***
No
- **Will Audio Enhancement be Installing? ***
Yes
- **Does this project utilize Davis Bacon rates or Prevailing Wage?**
No
- **Site Status at Any Point During Implementation ***
None of the above
- **Are there any drawings or specifications we are required to meet for this project? ***
No

This proposed design was finalized by Audio Enhancement. The customer approval of original design was bypassed by Taylor Noyes at 20 Dec, 2023 6:01 PM.

Explanation:

Approved by Nicole Regan via email., Bypassed by Taylor Noyes on 20 Dec, 2023 6:01 PM