

Board of Education Regular Meeting

Monday, January 11, 2016 7:00 PM

1. Call the meeting to order
2. Roll Call
3. Verification of Open Meetings Act Notice
4. Verification of publication of meeting notice
5. Consider and approve the current board meeting agenda
6. Reorganization of Board of Education
 - 6.1. Annual Election of Officers as per Franklin Public School Board Policy #8130
 - Scott Herrick made motion to nominate John Siel as President. Second by Raquel. Yes - Scott, Raquel, James, Les, and Kim. Abstain - John -Scott Herrick made motion to nominate Raquel Felzien as Vice President. Second by Les. Yes - Scott, Les, James, Kim, John. Abstain - Raquel. -James Haussermann made motion to nominate Kim Molzahn as Secretary. Second by Raquel. Yes - James, Raquel, John, Les, Scott. Abstain - Kim -Raquel Felzien made a motion to nominate Scott Herrick as Treasurer. Second by James. Yes - Raquel, James, John, Les, Kim. Abstain - Scott passed with a motion by Scott Herrick and a second by Raquel Felzien.
 - Raquel Felzien: Yea, James Haussermann: Yea, Scott Herrick: Yea, Kim Molzahn: Yea, Les Sidlo: Yea, John Siel: Yea
 - 6.2. Consider and approve selecting Greg Perry as legal counsel for Franklin Public Schools
 - Motion to approve Greg Perry as legal counsel passed with a motion by Raquel Felzien and a second by Les Sidlo.
 - Raquel Felzien: Yea, James Haussermann: Yea, Scott Herrick: Yea, Kim Molzahn: Yea, Les Sidlo: Yea, John Siel: Yea
 - Motion to consider and approve selecting Greg Perry as legal counsel for Franklin Public Schools passed with a motion by Raquel Felzien and a second by Les Sidlo.
 - Raquel Felzien: Yea, James Haussermann: Yea, Scott Herrick: Yea, Kim Molzahn: Yea, Les Sidlo: Yea, John Siel: Yea
 - 6.3. Consider and approve appointments to the Franklin Board of Education Committees as presented by Superintendent Candace Conradt
 - Approval of school board committees as presented by Dr. Conradt passed with a motion by Raquel Felzien and a second by Scott Herrick.
 - Raquel Felzien: Yea, James Haussermann: Yea, Scott Herrick: Yea, Kim Molzahn: Yea, Les Sidlo: Yea, John Siel: Yea
 - 6.4. Consider and approve selecting Franklin State Bank, South Central State Bank, and Cornerstone Bank as depository banks for Franklin Public Schools for 2016
 - Motion to consider and approve selecting Franklin State Bank, South Central State Bank, and Cornerstone Bank as depository banks for Franklin Public Schools for 2016 passed with a motion by Scott Herrick and a second by James Haussermann.
 - Raquel Felzien: Yea, James Haussermann: Yea, Scott Herrick: Yea, Kim Molzahn: Yea, Les Sidlo: Yea, John Siel: Yea
 - 6.5. Consider and approve selecting the Franklin Chronicle as the Franklin Public School District's newspaper of record for 2016

Motion to consider and approve selecting the Franklin Chronicle as the Franklin Public School District's newspaper of record for 2016 passed with a motion by Raquel Felzien and a second by James Haussermann.

Raquel Felzien: Yea, James Haussermann: Yea, Scott Herrick: Yea, Kim Molzahn: Yea, Les Sidlo: Yea, John Siel: Yea

6.6. Approval of current Board policies and regulations

Motion to consider and approve all current board policies passed with a motion by Les Sidlo and a second by Scott Herrick.

Raquel Felzien: Yea, James Haussermann: Yea, Scott Herrick: Yea, Kim Molzahn: Yea, Les Sidlo: Yea, John Siel: Yea

6.7. Dissemination of conflict of interest statutes to each board member as per Franklin Public Schools Board Policy 8130

7. Ace Recipients Recognition

8. Action Items

8.1. Consent Agenda

Motion to approve consent agenda passed with a motion by Kim Molzahn and a second by Raquel Felzien.

Raquel Felzien: Yea, James Haussermann: Yea, Scott Herrick: Yea, Kim Molzahn: Yea, Les Sidlo: Yea, John Siel: Yea

8.1.1. Minutes of previous meetings

8.1.2. Monthly Financial Report

8.1.3. Claims

8.1.4. Consider and approve declaring items as surplus for immediate disposal or sale

8.1.5. Consider and approve payment in the amount of \$2104.04 to Uline for locker room benches from the Depreciation Fund.

8.2. Consider and approve the purchase of a 16 case Milk Cooler

Motion to purchase a new 16 case milk cooler from Lee's refrigeration for \$2,117.00 passed with a motion by James Haussermann and a second by Scott Herrick.

Raquel Felzien: Yea, James Haussermann: Yea, Scott Herrick: Yea, Kim Molzahn: Yea, Les Sidlo: Yea, John Siel: Yea

9. Discussion Items

9.1. Discuss FPS Roof Options

9.2. Affordable Care Act

10. Visitor Comments

11. Elementary Principal's Report

12. Secondary Principal/Activities Director's Report

13. Superintendent's Report

14. Positive Comments

15. Adjournment

The motion to adjourn at 7:57 pm passed with a motion by Raquel Felzien and a second by James Haussermann.

Raquel Felzien: Yea, James Haussermann: Yea, Scott Herrick: Yea, Kim Molzahn: Yea, Les Sidlo: Yea, John Siel: Yea

Internal Board Policies - OrganizationAnnual Organizational Meeting

- A. An organizational meeting of the Franklin School District Board of Education shall be held on or before the third Monday of January of each year for the purposes of seating any new members and electing officers.

The following are procedures for election of officers and other business to take place at the annual organizational meeting of the Board:

1. After new Board members are sworn in, the Board will elect from its members a President, Vice President, Secretary and Treasurer, and if it is determined by the Board of Education to be needed an ex officio secretary and treasurer and those elected will assume office at the organizational meeting.
 2. Upon call for nominations for each office by the Chair, nominations shall be made by written or oral ballot. Voting will be by oral or written ballot on all members nominated and repeated until a majority is achieved for a nominee. If the tie is not broken after five ballots, the Chair will determine the winner by the flip of a coin, followed by a vote ratifying such selection. The vote may be taken by secret ballot, but the total number of votes for each candidate shall be recorded in the minutes of the meeting.
 3. The President shall assume the chair immediately upon the President's election.
- B. The order of business for meeting shall be as follows:
1. Call to Order and Roll Call
 2. Oath of office for most recently elected
 3. Elections
 - a. President
 - b. Vice President
 - c. Treasurer
 - d. Secretary
 4. Approval of committees, positions, and designations
 - a. Consider, discuss and take action to elect Secretary to the BOE
 - b. Consider, discuss and take action to select Legal counsel
 - c. Consider, discuss and take action to elect Committees as determined by the BOE

- d. Consider, discuss and take action to select Depository bank(s)
 - e. Consider, discuss and take action to select District newspaper(s) of record
5. Approval of current Board policies and regulations
 6. Designate date for the annual review of BOE policies
 7. Dissemination to each Board member of conflict of interest statutes
 8. Adjournment

Date of Adoption: April 9, 2012

RESOLUTION

RESOLVED, that the official depository of school funds for this School District is hereby designated to be _____, and that the designation of any other institution as the depository of school funds is hereby withdrawn.

The above Resolution, having been read in its entirety, member _____ moved for its passage and adoption, and member _____ seconded the same. After discussion and roll call vote, the following members voted in favor of passage and adoption of the above Resolution: _____

_____.
The following members voted against the same: _____

_____.
The following members were absent or not voting: _____

_____.
The above Resolution, having been consented to and approved by more than a majority of the members of the School Board of this School District, was declared as passed and adopted by the President at a duly held and lawfully convened meeting in full compliance with the Nebraska open meetings law.

DATED this ____ day of _____, 20__.

Franklin Public Schools

BY: _____
President

Attest:

Secretary

Legal Reference: Neb. Rev. Stat. §§ 77-2350 and 77-2350.01

Date of Adoption: April 9, 2012

Franklin Public Schools Board of Education 2016 Officers & Committee Assignments

President:_____

Vice President:_____

Secretary:_____

Treasurer:_____

Curriculum, Americanism, Staff Relations, & Policy Development Committee

James Haussermann, Chairperson

Les Sidlo

Kim Molzahn

Humpert Scholarship

Kim Molzahn, Chairperson

Les Sidlo

Raquel Felzien

Legislative Committee

Les Sidlo, Chairperson

James Haussermann

Kim Molzahn

Negotiations Committee

Raquel Felzien, Chairperson

Scott Herrick

John Siel

Transportation & Building and Grounds Committee

John Siel, Chairperson

James Haussermann

Scott Herrick

Finance Committee

Scott Herrick, Chairperson

Raquel Felzien

John Siel

CORPORATE AUTHORIZATION RESOLUTION

CORNERSTONE BANK
 529 LINCOLN AVENUE-P O BOX 69
 YORK, NEBRASKA 68467-0069

By: FRANKLIN PUBLIC SCHOOL DIST R #506

1001 M ST
 FRANKLIN NE 68939-1120

Referred to in this document as "Financial Institution"

Referred to in this document as "Corporation"

I, CANDACE M CONRADT, certify that I am Secretary (clerk) of the above named corporation organized under the laws of NEBRASKA, Federal Employer I.D. Number _____, engaged in business under the trade name of FRANKLIN PUBLIC SCHOOL DIST R #506, and that the resolutions on this document are a correct copy of the resolutions adopted at a meeting of the Board of Directors of the Corporation duly and properly called and held on _____ (date). These resolutions appear in the minutes of this meeting and have not been rescinded or modified.

AGENTS Any Agent listed below, subject to any written limitations, is authorized to exercise the powers granted as indicated below:

Name and Title or Position	Signature	Facsimile Signature (if used)
A. <u>CANDACE M CONRADT</u>	X _____	X _____
B. <u>MONICA A JAMES</u>	X _____	X _____
C. <u>PRESIDENT</u>	X _____	X _____
D. <u>TREASURER</u>	X _____	X _____
E. _____	X _____	X _____
F. _____	X _____	X _____

POWERS GRANTED (Attach one or more Agents to each power by placing the letter corresponding to their name in the area before each power. Following each power indicate the number of Agent signatures required to exercise the power.)

Indicate A, B, C, D, E, and/or F	Description of Power	Indicate number of signatures required
_____	(1) Exercise all of the powers listed in this resolution.	_____
_____	(2) Open any deposit or share account(s) in the name of the Corporation.	_____
_____	(3) Endorse checks and orders for the payment of money or otherwise withdraw or transfer funds on deposit with this Financial Institution.	_____
_____	(4) Borrow money on behalf and in the name of the Corporation, sign, execute and deliver promissory notes or other evidences of indebtedness.	_____
_____	(5) Endorse, assign, transfer, mortgage or pledge bills receivable, warehouse receipts, bills of lading, stocks, bonds, real estate or other property now owned or hereafter owned or acquired by the Corporation as security for sums borrowed, and to discount the same, unconditionally guarantee payment of all bills received, negotiated or discounted and to waive demand, presentment, protest, notice of protest and notice of non-payment.	_____
_____	(6) Enter into a written lease for the purpose of renting, maintaining, accessing and terminating a Safe Deposit Box in this Financial Institution.	_____
_____	(7) Other _____	_____

LIMITATIONS ON POWERS The following are the Corporation's express limitations on the powers granted under this resolution.

EFFECT ON PREVIOUS RESOLUTIONS This resolution supersedes resolution dated _____ NA _____. If not completed, all resolutions remain in effect.

CERTIFICATION OF AUTHORITY
 I further certify that the Board of Directors of the Corporation has, and at the time of adoption of this resolution had, full power and lawful authority to adopt the resolutions on page 2 and to confer the powers granted above to the persons named who have full power and lawful authority to exercise the same. (Apply seal below where appropriate.)

If checked, the Corporation is a non-profit corporation. In Witness Whereof, I have subscribed my name to this document and affixed the seal of the Corporation on _____ (date).

 Attest by One Other Officer

 Secretary

CORNERSTONE BANK

529 LINCOLN AVENUE-P O BOX 69
YORK, NEBRASKA 68467-0069

OWNERSHIP OF ACCOUNT - PERSONAL (Select One and Initial):

- Single-Party Account _____ Trust-Separate Agreement _____
- Multiple-Party Account _____
- Other _____

RIGHTS AT DEATH (Select One and Initial):

- Single-Party Account _____
- Multiple-Party Account With Right of Survivorship _____
- Multiple-Party Account Without Right of Survivorship _____
- Single-Party Account With Pay On Death _____
- Multiple-Party Account With Right of Survivorship and Pay On Death _____

PAY-ON-DEATH BENEFICIARIES: To Add Pay-On-Death Beneficiaries Name One or More:

OWNERSHIP OF ACCOUNT - BUSINESS PURPOSE

- SOLE PROPRIETORSHIP PARTNERSHIP
- CORPORATION: FOR PROFIT NOT FOR PROFIT
- LIMITED LIABILITY COMPANY
- PUBLIC

BUSINESS: _____
 COUNTY & STATE: _____
 OF ORGANIZATION: _____
 AUTHORIZATION DATED: _____

DATE OPENED 12/22/2015 BY DANIELLE COX

INITIAL DEPOSIT \$ _____

- CASH CHECK _____

HOME TELEPHONE # _____

BUSINESS PHONE # _____

DRIVER'S LICENSE # _____

E-MAIL _____

EMPLOYER _____

MOTHER'S MAIDEN NAME _____

Name and address of someone who will always know your location: _____

BACKUP WITHHOLDING CERTIFICATIONS

TIN:

TAXPAYER I.D. NUMBER - The Taxpayer Identification Number shown above (TIN) is my correct taxpayer identification number.

BACKUP WITHHOLDING - I am not subject to backup withholding either because I have not been notified that I am subject to backup withholding as a result of a failure to report all interest or dividends, or the Internal Revenue Service has notified me that I am no longer subject to backup withholding.

EXEMPT RECIPIENTS - I am an exempt recipient under the Internal Revenue Service Regulations.

SIGNATURE: I certify under penalties of perjury the statements checked in this section and that I am a U.S. citizen or other U.S. person (as defined in the instructions).

X _____ (Date)
BY MONICA A JAMES

ACCOUNT NUMBER

PORTFOLIO NUMBER

ACCOUNT OWNER(S) NAME & ADDRESS

FRANKLIN PUBLIC SCHOOL DIST R #506

1001 M ST
FRANKLIN, NE 68939-1120

- | | | |
|-----------------|--|--|
| TYPE OF ACCOUNT | <input checked="" type="checkbox"/> NEW | <input type="checkbox"/> EXISTING |
| | <input checked="" type="checkbox"/> CHECKING | <input type="checkbox"/> SAVINGS |
| | <input type="checkbox"/> MONEY MARKET | <input type="checkbox"/> CERTIFICATE OF DEPOSIT |
| | <input type="checkbox"/> NOW | <input checked="" type="checkbox"/> REGULAR CKG - PUBLIC |

Account Name: _____
 This is a Temporary account agreement.

Number of signatures required for withdrawal 1

FACSIMILE SIGNATURE(S) ALLOWED? YES NO

X

SIGNATURE(S) - The undersigned certifies the accuracy of the information he/she has provided and acknowledges receipt of a completed copy of this form. The undersigned authorizes the financial institution to verify credit and employment history and/or have a credit reporting agency prepare a credit report on the undersigned, as individuals. The undersigned also acknowledge the receipt of a copy and agree to the terms of the following agreement(s) and/or disclosure(s):

- Terms & Conditions Truth in Savings Funds Availability
- Electronic Fund Transfers Privacy Substitute Checks
- Common Features _____

(1): MONICA A JAMES Auth Signer
 I.D. # ON SYSTEM D.O.B. _____

(2): CANDACE M CONRADT Auth Signer
 I.D. # ON SYSTEM D.O.B. _____

(3): PRESIDENT
 I.D. # ON SYSTEM D.O.B. _____

(4): TREASURER
 I.D. # ON SYSTEM D.O.B. _____

AGENCY (POWER OF ATTORNEY) DESIGNATION (Optional): To Add Agency Designation To Account, Name One or More Agents:

- (Select One and Initial):
- Agency Designation Survives Disability or Incapacity of Parties _____
 - Agency Designation Terminates on Disability or Incapacity of Parties _____

529 LINCOLN AVENUE-P O BOX 69
YORK, NEBRASKA 68467-0069

TRUTH IN SAVINGS DISCLOSURE

Terms following a apply only if checked.

Acct: 21 REGULAR CHECKING - PUBLIC FUNDS

Acct #:

Date: 12/22/2015

The interest rate and annual percentage yield stated below are accurate as of the date printed above. If you would like more current rate and yield information please call us at (402)363-7411.

This disclosure contains the rules which govern your deposit account. Unless it would be inconsistent to do so, words and phrases used in this disclosure should be construed so that the singular includes the plural and the plural includes the singular.

We reserve the right to at any time require not less than _____ days notice in writing before any withdrawal from an interest bearing account.

FIXED RATE

The interest rate for your account is _____ % with an annual percentage yield of _____ %. We will pay this rate _____ . We will not decrease this rate unless we first give you at least 30 days notice in writing.

The interest rate and annual percentage yield for your account depend upon the applicable rate tier. We will pay these rates _____ .

We will not decrease these rates unless we first give you at least 30 days notice in writing.

VARIABLE RATE

The interest rate for your account is _____ % with an annual percentage yield of _____ %. Your interest rate and annual percentage yield may change.

The interest rate and annual percentage yield for your account depend upon the applicable rate tier. The interest rate and annual percentage yield for these tiers may change.

Determination of rate

At our discretion, we may change the interest rate on your account.

The interest rate for your account _____

The fixed initial rate is not determined by this rule.

The initial interest rate on your account _____

Subsequent rates _____

Frequency of rate change

We may change the interest rate on your account _____

Your initial interest rate will not change _____

We may change the interest rate on your account at that time and _____ thereafter.

Limitations on rate changes

The interest rate for your account will not _____ by more than _____ each _____ .

The interest rate will not be less than _____ % or more than _____ %.

The interest rate will not _____

_____ the interest rate initially disclosed to you.

Minimum Balance Requirements

To open the account. You must deposit at least \$ _____ to open this account.

To avoid imposition of fees.

To avoid the imposition of the _____ you must meet _____ following requirements:

A _____ of \$ _____ will be imposed every _____

if the balance in the account falls below \$ _____ any day of the _____ .

A _____ of \$ _____ will be imposed every _____

if the average daily balance for the _____ falls below \$ _____ . The

average daily balance is calculated by adding the principal in the account for each day of the period and dividing that figure by the number of days in the period.

The period we use is _____ .

To avoid the imposition of the _____ you must meet _____ following requirements:

A _____ of \$ _____ will be imposed for _____

transaction (withdrawal, check paid, automatic transfer or payment out of your account) if the balance in the account

falls below \$ _____ any day of the _____ .

A _____ of \$ _____ will be imposed for _____

transaction (withdrawal, check paid, automatic transfer or payment out of your account) if the average daily balance for the

_____ falls below _____

Franklin Public Schools
Resolution To Transact Financial Business with Franklin State Bank on the District's
Behalf

Let it be resolved at the Regular January 11, 2016 Board Meeting of the Franklin Public Schools Board of Education that Franklin Public School Board President, _____; Franklin Public School Board Treasurer, _____; Franklin Public School Bookkeeper, Monica James; and Franklin Public School Superintendent, Candace Conradt, be authorized and directed to transact any and all necessary financial business on behalf of the Franklin Public School District on the following Franklin State Bank accounts: Activity Account #_____, Lunch Account #_____, Cafeteria Account #_____, General Fund Account #_____, Building Fund Account #_____, Depreciation Fund Account #_____, Unemployment Account #_____, and investments CD #'s: _____, _____, _____ and _____ including but not limited to:

1. Open and maintain accounts;
2. Make deposits to the accounts;
3. Endorse for negotiation, negotiate, and receive the proceeds of any negotiable instrument, check, draft, or order for the payment of money payable to or belonging to the school by writing, stamp, or other means permitted by this resolution without the designation of the person endorsing;
4. Make withdrawals from the accounts in any manner permitted by the accounts;
5. Transfer funds from the accounts to any account whether or not held at Franklin State Bank and whether or not held by the school;
6. Transfer funds to the accounts from any account whether or not held at Franklin State Bank;
7. Approve, endorse, guarantee, and identify the endorsement of any payee or any endorser of any negotiable instrument, check, draft or order for the payment of money whether drawn by the school or anyone else and guarantee the payment of any negotiable instrument, check, draft, or order for the payment of money, and;
8. Delegate to others the authority to approve, endorse, guarantee, and identify the endorsement of any payee or endorser on any negotiable instrument, check, draft, or order for the payment of money and to guarantee the payment of any such negotiable instrument, check, draft, or order for the payment of money.

The undersigned certifies that _____, _____, Monica James, Ingrid Lennemann, & Candace Conradt are the duly appointed Board President, Board Treasurer, Bookkeeper, Activity Fund Bookkeeper, and Superintendent, respectively, of the Franklin Public Schools District and that this resolution is being duly adopted by a majority vote at a meeting of the Franklin Public School Board, which is being held in accordance with the State Open Meetings Act Law and the Bylaws of the Franklin Board of Education.

Dated: January 11, 2016

President's Signature: _____
(_____)

Treasurer's Signature: _____
(_____)

Bookkeeper's, Signature: _____
(Monica James)

Assistant Bookkeeper's Signature _____
(Ingrid Lennemann)

Superintendent's Signature _____
(Candace Conradt)

RESOLUTION OF ASSOCIATION OR ORGANIZATION

DATE 1/11/2016

TO: NAME/ ADDRESS OF FINANCIAL INSTITUTION ("Financial Institution") SOUTH CENTRAL STATE BANK-FRANKLIN PO BOX 173 FRANKLIN NE 68939 (308) 425-6215 01 FROM: NAME / ADDRESS OF ASSOCIATION OR ORGANIZATION ("Organization") FRANKLIN PUBLIC SCHOOLS DISTRICT #506 GENERAL FUND 1001 M STREET FRANKLIN, NE 68939

Use this Resolution Of Association Or Organization to Open Account(s), to Deposit and Withdraw Funds, and to Open and Have Access to Safe Deposit Boxes, as well as sign Agreements on behalf of the Association or Organization for ATM or Debit Cards, Night Depository services, Lock Box services, and Cash Management.

Words, numbers or phrases preceded by a [] are applicable only when marked, i.e., [X]

THIS IS TO CERTIFY THAT, I am the duly elected and qualified [X] Secretary [] Clerk and keeper of the records of the above-named Organization and that the following is a true copy of this Resolution duly adopted by the officers of said Organization at a meeting held on the 11TH day of JANUARY, 2016, at which a quorum was present, and that such Resolution is still in full force and effect and has not been amended or rescinded.

This is a [] For Profit [X] Nonprofit Organization.

IT IS RESOLVED THAT:

Pursuant to authority contained in the By-Laws of the Organization, the said officers of the Organization have duly designated Financial Institution as a depository of the funds of the Organization. By virtue of said election, the By-Laws and the afore-said designation, the following described officers, and designated parties or agents, if any, referred to below as "Authorized Signer" or "Authorized Signers" and whose names and signatures appear below, are authorized for and on behalf of the Organization to have the following indicated powers as contained in this Resolution:

DEPOSITORY ACCOUNT. Perform the following for the account(s) indicated on Page 2, in the name of the Organization, subject to any terms and conditions governing the account(s), such as: -Authorized Signers

- 1. Open and maintain the account(s);
2. Make deposits to the account(s);
3. Endorse for negotiation, negotiate, and receive the proceeds of any negotiable instrument, check, draft, or order for the payment of money payable to or belonging to the Organization by writing, stamp, or other means permitted by this Resolution without the designation of the person endorsing;
4. Make withdrawals from the account(s) in any manner permitted by the account(s);
5. Transfer funds from the account(s) in Financial Institution to any account whether or not held at this Financial Institution and whether or not held by this Organization;
6. Transfer funds to the account(s) in Financial Institution from any account whether or not held at this Financial Institution and whether or not held by this Organization;
7. Approve, endorse, guarantee, and identify the endorsement of any payee or any endorser of any negotiable instrument, check, draft or order for the payment of money whether drawn by the Organization or anyone else and guarantee the payment of any negotiable instrument, check, draft, or order for the payment of money; and
8. Delegate to others the authority to approve, endorse, guarantee, and identify the endorsement of any payee or endorser on any negotiable instrument, check, draft, or order for the payment of money and to guarantee the payment of any such negotiable instrument, check, draft, or order for the payment of money.
9. All of the above.

ALL SIGNERS

SAFE DEPOSIT BOX. Lease a Safe Deposit Box(es) with Financial Institution, make inspections of, deposits to and removals from Box(es); and exercise all rights and be subject to all responsibilities under the Lease.

NIGHT DEPOSITORY. Enter into a Night Depository Agreement with Financial Institution and exercise all rights and be subject to all responsibilities under the Agreement.

LOCK BOX. Enter into a Lock Box Agreement with Financial Institution and exercise all rights and be subject to all responsibilities under the Agreement.

DEBIT CARD/ATM CARD. Apply for, receive and utilize debit cards, automated teller machine cards, or other access devices to exercise those powers authorized by this Resolution or other Resolutions then in effect.

CASH MANAGEMENT. Enter into a Cash Management Agreement with Financial Institution, and exercise all rights and be subject to all responsibilities under the Agreement.

OTHER AUTHORITY describe: ONLINE BANKING AND BILL PAY

Further, this Resolution continues on Page 2 of this document, and all of the power and authority granted are incorporated in this Resolution.

RESOLUTION APPLIES TO (check all that apply): ALL ACCOUNTS SAFE DEPOSIT BOX NUMBER(S):
 ALL FUTURE ACCOUNTS SPECIFIC ACCOUNTS - NUMBER(S):

NAME AND TITLE	SIGNATURE	LIMITATIONS
1. DR. CANDACE CONRADT SUPERINTENDENT	X	COUNTERSIGNERS: X
2. MONICA JAMES AUTHORIZED SIGNER	X	COUNTERSIGNERS: 1
3. PRESIDENT	X	COUNTERSIGNERS: 1
4. TREASURER	X	COUNTERSIGNERS: 1
5.	X	COUNTERSIGNERS:
6.	X	COUNTERSIGNERS:
7.	X	COUNTERSIGNERS:
8.	X	COUNTERSIGNERS:

SIGNATURE CERTIFICATION. The undersigned certifies that he/she is the Secretary/Clerk and keeper of the above-named Organization's official records, and is duly authorized to make this certification on its behalf.

By X _____ Attest By X _____
Secretary/Clerk Date President Date

IT IS FURTHER RESOLVED AS FOLLOWS, the Secretary/Clerk of this Organization certifies to the Financial Institution that:

- The Secretary/Clerk and keeper of the records of this Organization shall certify to the Financial Institution the names of the persons who are at present authorized to act on behalf of this Organization under this Resolution and shall from time to time hereafter, as changes in the personnel of said officers are made, immediately certify such changes to the Financial Institution. The Financial Institution shall be fully protected in relying on such certifications of the Secretary/Clerk and shall be indemnified and held harmless from any claims, demands, expenses, loss or damage resulting from, or growing out of, honoring the signature of any officer so certified, or refusing to honor any signature not so certified;
- Unless specifically designated, each of the Authorized Signers whose signature appears above may sign without the other(s);
- (Select if applicable) **FACSIMILE SIGNATURES.** The Financial Institution shall be entitled to honor and charge the Organization for all such negotiable instruments, checks, drafts, or other orders for payment of money drawn in the name of the Organization, on the indicated account(s), including an order for electronic debit, whether by electronic tape or otherwise, regardless of by whom or by what means a facsimile signature or other non-manual signature (collectively, "Facsimile Signatures") may have been affixed, or electronically communicated, if such Facsimile Signatures resemble the specimens duly certified to or filed with the Financial Institution for any of the named Authorized Signers, regardless of whether any misuse is with or without the negligence of the Organization. The Specimen Facsimile Signature Exhibit, when attached, is incorporated into and is an integral part of this Resolution. The Organization agrees that the duty of maintaining the security of any such Facsimile Signatures or device by which they are affixed is solely that of the Organization. Your authorization notwithstanding, Financial Institution is not obligated to accept or pay any items bearing Facsimile Signatures;
- As used herein, any pronouns relative to the signers for the Organization shall include the masculine, feminine, and neutral gender, and the singular and plural number, wherever the context so admits or requires;
- All items deposited with prior endorsements are guaranteed by the Organization;
- All items not clearly endorsed by the Organization may be returned to the Organization by the Financial Institution or, alternatively, the Financial Institution is granted a power of attorney in relation to any such item to endorse any such item on behalf of the Organization in order to facilitate collection;
- Financial Institution shall have no liability for any delay in the presentment or return of any negotiable instrument or other order for the payment of money, that is not properly endorsed;
- Financial Institution is directed and authorized to act upon and honor any withdrawal or transfer instructions issued and to honor, pay and charge to any depository account or accounts of the Organization, all checks or orders for the payment of money so drawn when signed consistent with this Resolution without inquiring as to the disposition of the proceeds or the circumstances surrounding the issuance of the check or the order for the payment of the money involved, whether such checks or orders for the payment of money are payable to the order of, or endorsed or negotiated by any one or more of the Authorized Signers signing them or such party in their individual capacities or not, and whether they are deposited to the individual credit of or tendered in payment of the individual obligation of any one or more of the Authorized Signers signing them or of any other such party or not;
- All transactions by any of the officers, employees or agents of the Organization on its behalf, and in its name, with the Financial Institution prior to the delivery to the Financial Institution of a certified copy of the foregoing Resolution are, in all respects, hereby ratified, confirmed, approved and adopted; and
- Notwithstanding any modification or termination of the power of any Authorized Signer of the Organization, this Resolution shall remain in full force and bind the Organization and its legal representatives, successors, assignees, receivers, trustees or assigns until written notice to the contrary signed by, or on behalf of, the Organization shall have been received by the Financial Institution, and that receipt of such notice shall not affect any action taken by the Financial Institution prior to receipt of such notice in reliance on this Resolution.

Additional comments or instructions:

See attachment for additional instructions or comments. Attachment must be dated and properly authorized.

<p style="text-align: center;">NEBRASKA ACCOUNTABILITY AND DISCLOSURE COMMISSION 11th Floor, State Capitol P.O. Box 95086 Lincoln, NE 68509 (402) 471-2522</p>	<h1 style="margin: 0;">EMPLOYMENT OF IMMEDIATE FAMILY MEMBERS DISCLOSURE STATEMENT</h1> <h2 style="margin: 10px 0 0 0;">NADC FORM C-4</h2>	<table border="1" style="width:100%; border-collapse: collapse;"> <tr> <td style="width:50%; font-size: small;">POSTMARK DATE</td> <td style="width:50%;"></td> </tr> <tr> <td style="font-size: small;">MICROFILM NUMBER</td> <td></td> </tr> <tr> <td colspan="2" style="text-align: center; font-size: small;">OFFICE USE ONLY</td> </tr> <tr> <td colspan="2" style="height: 80px;"></td> </tr> </table>	POSTMARK DATE		MICROFILM NUMBER		OFFICE USE ONLY			
POSTMARK DATE										
MICROFILM NUMBER										
OFFICE USE ONLY										
<p style="text-align: center;">BEFORE COMPLETING THIS FORM READ THE FILING REQUIREMENTS ON PAGE 3</p>										

- Public officials and employees employing, recommending employment, or supervising the employment of an immediate family member must disclose the employment either in writing or on the record to the governing body employing the immediate family member.
- File this form or other written disclosure with the person in charge of keeping records for the governing body employing the immediate family member.
- Person who fail to disclose the employment of immediate family members or who otherwise do not comply with the law are subject to penalties.

ITEM 1	NAME, ADDRESS AND TELEPHONE NUMBER OF PUBLIC OFFICIAL OR PUBLIC EMPLOYEE
---------------	---

Name _____	Telephone No. _____
<div style="display: flex; justify-content: space-between;"> Last First Middle </div>	
Address _____	
STREET ADDRESS OR RURAL ROUTE	City
STATE	ZIP CODE

ITEM 2	OFFICE OR POSITION, ADDRESS, TELEPHONE, TERM OF OFFICE
---------------	---

Office or Position: _____	Term: _____
Identify City, County, District, or State Agency: _____	
Address: _____	
Telephone _____	

ITEM 3	MEMBER OF YOUR IMMEDIATE FAMILY WHOM YOU INTEND TO EMPLOY, RECOMMEND FOR EMPLOYMENT, OR SUPERVISE (Use ITEM 5 CONTINUATION, if necessary)
---------------	--

A. Name _____	Relationship _____
Position _____	Employer _____ (IDENTIFY CITY, COUNTY, DISTRICT OR STATE AGENCY)
B. Name _____	Relationship _____
Position _____	Employer _____ (IDENTIFY CITY, COUNTY, DISTRICT OR STATE AGENCY)
C. Name _____	Relationship _____
Position _____	Employer _____ (IDENTIFY CITY, COUNTY, DISTRICT OR STATE AGENCY)

ITEM 4 | FOR NEWLY ELECTED OR APPOINTED PUBLIC OFFICIALS AND EMPLOYEES

List members of your immediate family who were employed before your election or appointment, or prior to July 17, 1986 and are now employed or supervised by you.

A. Name _____ Relationship _____

Position _____ Employer _____
(IDENTIFY CITY, COUNTY, DISTRICT OR STATE AGENCY)

Date Hired _____

B. Name _____ Relationship _____

Position _____ Employer _____
(IDENTIFY CITY, COUNTY, DISTRICT OR STATE AGENCY)

Date Hired _____

(Use ITEM 5, CONTINUATION, if necessary)

ITEM 5 | CONTINUATION

Empty space for continuation of information.

(Signature)

(Date)

General Information - Filing Requirements

A public official or public employee may employ, recommend the employment of, or supervise the employment of an immediate family member if:

- 1) he or she does not abuse his or her official position; and
- 2) makes a written disclosure with the person in charge of keeping records for the governing body or a disclosure on the record to the governing body; and
- 3) he or she has first made a reasonable solicitation and consideration of applications for such employment:

NOTE: Examples of abuse of one's position could include, but are not limited to, (1) providing an unreasonably high salary, (2) not requiring the employee to actually perform the duties of his or her position, (3) terminating another employee to make a position available for an immediate family member, (4) hiring an immediate family member who is not qualified to hold the position.

I. Who Must File:

- A. Public officials and employees employing, recommending employment, or supervising the employment of an immediate family member must make a disclosure to the person in charge of keeping records for the governing body of the entity. Where applicable the disclosure may be made on the record to the governing body of the entity in lieu of a written disclosure.
- B. Public officials and employees who currently employ or supervise an immediate family member(s) employed prior to the election or appointment of the public official or public employee or prior to July 17, 1986.

II. When to File:

- A. Public officials and employees must file prior to employing, recommending employment, or supervising the employment of an immediate family member.

Governing body means the village board of a village, the city council of a city, the board of commissioners or board of supervisors of a county, the board of directors of a public power district, or any body with the ultimate power to determine the entity's policies and control its activities.

Immediate Family Member means a child residing in an individual's household, a spouse of an individual, or an individual claimed by the public official or employee or his or her spouse as a dependent for federal income tax purposes.

Public employee means an employee of the state or a political subdivision thereof.

Public official shall mean an official in the executive branch, an official in the legislative branch, or an elected or appointed official in the judicial branch of the state government or a political subdivision thereof; any elected or appointed members of a governing body of a state institution of high education.

- B. Newly elected or appointed public officials or employees shall file prior to or as soon as reasonably possible after the official date of taking office.

III. Where to File:

This form or other written disclosure should be filed with the person in charge of keeping records for the governing body of the entity served. (i.e., state officials and employees file with the head of their agency or department; officials and employees of public power districts file with the district office; county officials and employees file with the county clerk; city or village officials or employees file with the city or village clerk; officials and employees of natural resource districts file with the office of the district manager; school district officials and employees file with the district superintendent or secretary of the school board. **Disclosure need not be made to the Nebraska Accountability and Disclosure Commission.**

Disclosure of Contractual Interests by Local Officers. If you are disclosing an interest in a contract to which a local governing body on which you serve is a party, use NADC Form C-3, Contractual Interest Statement.

Disclosure of Potential Conflict of Interest by State Executive Branch Officials, Employees, and Others Required to file Statements of Financial Interests. If you are disclosing a potential conflict of interest under section 49-1499 of the Accountability Act, use NADC Form C-2, Potential Conflict of Interest Statement.

Definitions

Official in the executive branch means an official holding a state executive office as provided in Article IV, Constitution of Nebraska, including Governor, Lieutenant Governor, Secretary of State, Auditor of Public Accounts, State Treasurer, Attorney General, Tax Commissioner, the heads of such other executive departments as set forth in the Constitution or as may be established by law, a deputy thereto, or a member of any state board or commission.

Official in the legislative branch means a member or member-elect of the Legislature, a member of an official body established by and responsible to the Legislature, or employee thereof other than an individual employed by the state in a clerical or nonpolicymaking capacity.

Statutory Authority: Section 49-1499.01 Revised Statutes of Nebraska.

Conflicts of Interest

State and local public officials and public employees are subject to the conflicts of interest provisions of the Nebraska Political Accountability and Disclosure Act (NPADA). Not all of the conflicts provisions of the NPADA apply to all categories of public officials and public employees. The following are the main categories of the conflicts provisions:

- 1 Conflicts of Interest - Certain categories of public officials have a potential conflict of interest if they are faced with taking an official action or making an official decision which may result in a financial benefit or detriment to the public official or public employee, a member of his or her immediate family, or business with which he or she is associated. A public official or employee with a potential conflict of interest is required to disclose the conflict in writing. If he or she has an actual conflict of interest, he or she is required to abstain from participating or voting on the matter. For specific information in this area, contact the Commission General Counsel.
- 2 Interest in a Contract - Generally public officials and public employees may not have an interest in a contract with the governmental entity which they serve. An official or employee may have an interest in a contract if he or she, a member of his or her family, or a business with which he or she is associated. The prohibition against having an interest in a contract does not apply if the public official or public employee takes certain steps to disclose the interest and abstains from taking action to approve the contract, make payment under the contract, or act on behalf of the governmental entity to insure performance of the contract. For specific information, contact the Commission General Counsel.
- 3 Use of Public Resources - Public officials and public employees may not use, or authorize the use of public resources, personnel, property or funds under their official care and control for:
 - 1 Personal Financial gain or the financial gain of an immediate family member or business association.
 - 2 Purpose other than those provided by law; or
 - 3 The Purpose of supporting or opposing the nomination or election of a candidate or the qualification, passage or defeat of a ballot question.
- 4 Employment of Immediate Family Members (State) - State officials and state employees are prohibited from employing, recommending the employment of, or supervising the employment of an immediate family member. State law provides certain exceptions. For specific information contact the Commission General Counsel.
- 5 Hiring of Immediate Family Members (Local Government) - Local officials and local employees may employ, recommend the employment of, or supervise the employment of an immediate family member. However, certain disclosures must be made and other requirements met. For specific information contact the Commission General Counsel.
- 6 Statements of Financial Interests - Certain categories of public officials and public employees must file Statements of Financial Interests. A Statement

of Financial Interests discloses the sources of income, business associations and financial holdings of the filing public official or public employee. To view or secure copies of a Statement of Financial Interests, contact the Commission Office.

Applicable Forms

- Statement of Financial Interests (NADC Form C-1)
- Potential Conflict of Interest Statements (NADC Form C-2)
- Contractual Interest Statement (NADC Form C-3)
- Employment of Immediate Family Member Disclosure Statement (NADC Form C-4)

For specific information contact the Commission General Counsel. Disclosure forms under the Conflict of Interest provisions can be viewed or downloaded by clicking on Download Forms.



FRANKLIN PUBLIC SCHOOLS
IS PLEASED TO ANNOUNCE OUR
DECEMBER FLYER A.C.E.s
(ABOVE COMMON EXPECTATIONS)



Allison Boettcher was selected as the Elementary ACE Flyer for the month of December. Her teacher, Mrs. James, shared that Allison is a fantastic role model in the classroom and in the hallways. She is terrific at keeping her area clean and loves to help others. Keep it up!



Breanna Brandt was selected as the MS/HS ACE Flyer for the month of December. Breanna was nominated by Mrs. Simmons for her pleasant smile and helping personality. Mrs. Simmons shared that Breanna always has a contagious smile. Breanna is helpful to others as well.

The monthly ACE winner is drawn randomly from a group of students that were recognized in their classroom for their positive behavior.

This ad is sponsored by Franklin Public Schools.

Franklin Public Schools Board Of Education Meeting Minutes

December 14, 2015 @ 7:00 PM
Franklin Public Schools Media Center

Board Members Present & Absent

1. Call the meeting to order

Discussion:

The regular, meeting of the Franklin Public School Board was opened at 7:00 PM.

2. Roll Call

3. Verification of Open Meetings Act Notice

Discussion:

Board Member Les Sidlo verified that the Open Meetings Notice was posted in the Franklin Public School's Media Center.

4. Verification of publication of meeting notice

Discussion:

Board Member Scott Herrick verified that the meeting notice was published in the Franklin Chronicle.

5. Consider and approve the current board meeting agenda

Motion Passed: Motion to approve the current month's board meeting agenda as presented passed with a motion by Raquel Felzien and a second by Les Sidlo.

Raquel Felzien	Yes
James Haussermann	Yes
Scott Herrick	Yes
Kim Molzahn	Yes
Les Sidlo	Yes
John Siel	Yes

6. Action Items

6.1. Consent Agenda

Motion Passed: Motion to approve consent agenda passed with a motion by Scott Herrick and a second by Raquel Felzien.

Raquel Felzien	Yes
James Haussermann	Yes
Scott Herrick	Yes
Kim Molzahn	Yes
Les Sidlo	Yes
John Siel	Yes

6.1.1. Minutes of previous meetings

6.1.2. Monthly Financial Report

6.1.3. Claims

6.1.4. Consider and approve payment in the amount of \$1,122.86 from the Depreciation Fund to Omaha Stage Equipment, Inc.

6.1.5. Consider and approve payment in the amount of \$4368.00 from the Depreciation Fund to Lee French Bleacher Repair.

6.1.6. Consider and approve declaring items as surplus for immediate disposal or sale

6.2. Consider and approve setting up an account with Cornerstone Bank and identifying account signers for payroll.

Motion Passed: Motion to approve the setup of a payroll account with Cornerstone Bank for the purpose of direct deposits. passed with a motion by Raquel Felzien and a second by Les Sidlo.

Raquel Felzien	Yes
James Haussermann	Yes
Scott Herrick	Yes
Kim Molzahn	Yes
Les Sidlo	Yes
John Siel	Yes

6.3. Consider and Approve Board Policy 9320 "Order of Business"

Motion Passed: To approve board policy 9320 "Order of Business". passed with a motion by Kim Molzahn and a second by Scott Herrick.

Raquel Felzien	Yes
James Haussermann	Yes
Scott Herrick	Yes
Kim Molzahn	Yes
Les Sidlo	Yes
John Siel	Yes

6.4. Consider and approve "Negotiated Agreement" with the Franklin Teachers Association for the 2016-17 School Year

Motion Passed: Motion to approve "Negotiated Agreement" with the Franklin Teachers Association for the 2016-17 School Year passed with a motion by Raquel Felzien and a second by Kim Molzahn.

Raquel Felzien	Yes
James Haussermann	Yes
Scott Herrick	Yes
Kim Molzahn	Yes
Les Sidlo	Yes
John Siel	Yes

6.5. Identify Board Expectations for the School/Community Partnership for Essential Planning

Motion Passed: Motion to approve board expectations as community involvement, information about current programs and course offerings, and obtain information about current programs, course offerings, and demographics including facilities and finances, passed with a motion by Scott Herrick and a second by Raquel Felzien.

Raquel Felzien	Yes
James Haussermann	Yes
Scott Herrick	Yes
Kim Molzahn	Yes
Les Sidlo	Yes
John Siel	Yes

6.6. Consider and Approve Superintendent's Contract

Discussion:

I have attached the 2015/16 Superintendent Salaries. The schools in the array we used for teacher negotiations are highlighted on this list.

I have also attached a copy of my current contract.

Motion Passed: Motion to approve superintendent's contract as discussed. passed with a motion by Raquel Felzien and a second by Les Sidlo.

Raquel Felzien	Yes
James Haussermann	Yes
Scott Herrick	Yes

Kim Molzahn	Yes
Les Sidlo	Yes
John Siel	Yes

7. Discussion Items

7.1. ACE Recipients Recognition

7.2. FCCLA Presentation

7.3. FFA Presentation

7.4. Presentation of 2014/15 Audit

7.5. Board Members Terms & 2015 Committee Assignments

Discussion:

Please have committee preferences turned in by January meeting.

7.6. Superintendent's Evaluation (Possible Executive Session)

8. Visitor Comments

9. Board Members' Reports from State Education Conference

10. Elementary Principal's Report

11. Secondary Principal/Activities Director's Report

Discussion:

Benches can be ordered.

12. Superintendent's Report

13. Positive Comments

Discussion:

Elementary concert was excellently! –Kim

Thank you to the administration and teachers for their work on the social committee! - Raquel

Thank you to Gary Holmes for his years of service! You will be greatly missed! – Monica

Thank you to Monica and everyone who assisted with the recent audit. – Scott

Thank you to Clark Vetter and his classes for the excellent work on the completion of the concrete work out by the ball field! - John

Congratulations to the basketball teams and wrestling teams on a great start to the season! - James

14. Adjournment

Motion Passed:

Motion to adjourn passed with a motion by Scott Herrick and a second by Les Sidlo.

Raquel Felzien	Yes
James Haussermann	Yes
Scott Herrick	Yes
Kim Molzahn	Yes
Les Sidlo	Yes
John Siel	Yes

Franklin Public Schools Board Of Education Meeting Minutes

School/Community Partnership for Essential Planning Meeting

January 04, 2016 @ 6:00 PM

Franklin Public Schools Media Center

Board Members Present & Absent

Attendance Taken at 6:03 PM:

Present Board Members:

Raquel Felzien

James Haussermann

Scott Herrick

Kim Molzahn

Les Sidlo

John Siel

1. Call the meeting to order

Discussion:

The regular, meeting of the Franklin Public School Board was opened at 6:03 PM.

2. Roll Call

3. Verification of Open Meetings Act Notice

Discussion:

Board Member Scott Herrick verified that the Open Meetings Notice was posted in the Franklin Public School's Media Center.

4. Verification of publication of meeting notice

Discussion:

Board Member Raquel Felzien verified that the meeting notice was published in the Franklin Chronicle.

5. Consider and approve the current board meeting agenda

Motion Passed: Motion to approve the current month's board meeting agenda as presented by passed with a motion by Raquel Felzien and a second by Kim Molzahn.

Raquel Felzien Yes

James Haussermann Yes

Scott Herrick Yes

Kim Molzahn Yes

Les Sidlo Yes

John Siel Yes

6. School/Community Partnership for Essential Planning Meeting Facilitated by Mr. Don Fritz

Discussion:

Mr. Don Fritz facilitated the School/Community Partnership for Essential Planning meeting.

7. Adjournment

Motion Passed: Adjournment at 8:21 pm was passed with a motion by Raquel Felzien and a second by Scott Herrick.

Raquel Felzien Yes

James Haussermann Yes

Scott Herrick Yes

Kim Molzahn Yes

Les Sidlo Yes

John Siel Yes

General Fund
December 31, 2015

Check Beginning Balance		11/30/15		\$628,507.79	
	Claims for 12/14/15 Meeting			(\$114,563.66)	
	December Local PPD Claims			(\$1,029.76)	
	Payroll			(\$309,462.17)	
	Lunch Fund Reim for Payroll			\$6,294.98	
	Dir Dep's, Deposits & Int			\$66,417.48	
	NPERS rounding adjustment			(\$0.01)	
	End of Month Checking Balance				\$276,164.65
		11/30/15		\$921,440.92	
	12/2015 Interest			\$105.42	
		12/31/15			\$921,546.34
Total General Fund 12/31/15					\$1,197,710.99
				\$329,816.72	
	Checking FSB 12/31/15			(\$53,652.07)	
	Less Outstanding checks			\$0.00	
	Plus Outstanding Deposits				\$276,164.65
	12/31/15				
FSB	CD # 33723			\$106,957.05	2/1/16 3 Mths
FSB	CD # 34032			\$316,907.11	3/1/16 6 Mth
FSB	CD # 34800			\$300,264.66	2/26/16
SCSB	CD # 402352			\$123,224.15	2/1/16 Mthly
SCSB	CD # 402354			\$74,193.37	2/1/16 Mthly
	Investment Total 12/31/15				\$921,546.34
Recon Total		12/31/15			\$1,197,710.99

Regular; Processing Month 12/2015; Fund Number 01

Fund: 01 GENERAL FUND

Account Number	Description	Revised Budget	During Month	To Date	% of Budget	Budget Balance
01 1110	LOCAL PROPERTY TAX	4,637,500.00	14,361.66	1,225,630.01	26.43	3,411,869.99
01 1115	CARLINE TAX	0.00	0.00	38.33	0.00	(38.33)
01 1125	MOTOR VEHICLE TAX	135,000.00	4,865.92	32,422.46	24.02	102,577.54
01 1240	TUITION REC FROM INDIVID - SP ED	2,500.00	0.00	0.00	0.00	2,500.00
01 1270	PRE-SCHOOL TUITION	0.00	0.00	680.00	0.00	(680.00)
01 1410	INTEREST	5,000.00	222.18	1,897.30	37.95	3,102.70
01 1610	LOCAL LICENSES AND FEES	1,000.00	0.00	1,078.00	107.80	(78.00)
01 1620	POLICE COURT FINES	0.00	684.00	834.00	0.00	(834.00)
01 1920	CONTRIBUTIONS & DONATIONS	0.00	0.00	1,500.00	0.00	(1,500.00)
01 1990	OTHER LOCAL RECEIPTS	0.00	0.00	0.00	0.00	0.00
Subtotal: LOCAL RECIEPTS		4,781,000.00	20,133.76	1,264,080.10	26.44	3,516,919.90
01 2110	COUNTY FINES AND LIC. FEES	5,000.00	1,196.06	2,818.84	56.38	2,181.16
01 2130	OTHER COUNTY RECEIPTS	0.00	0.00	0.00	0.00	0.00
01 2210	ED SERVICE UNIT RECEIPTS	0.00	0.00	585.00	0.00	(585.00)
Subtotal: COUNTY AND ESU RECEIPTS		5,000.00	1,196.06	3,403.84	68.08	1,596.16
01 3110	STATE AID	45,959.00	4,595.86	18,383.44	40.00	27,575.56
01 3120	S.P.E.D.	200,000.00	35,483.00	35,483.00	17.74	164,517.00
01 3125	SPECIAL ED TRANSPORTATION SCHOOL AGE	0.00	0.00	0.00	0.00	0.00
01 3130	HOMESTEAD EXEMPTION	0.00	0.00	0.00	0.00	0.00
01 3131	RELIEF TO PROPERTY TAX	0.00	0.00	0.00	0.00	0.00
01 3135	HIGH ABILITY LEARNERS	4,256.00	0.00	4,326.00	101.64	(70.00)
01 3180	PRO-RATE MOTOR VEHICLE	5,000.00	0.00	1,040.33	20.81	3,959.67
01 3200	STATE APPORTIONMENT	35,000.00	0.00	0.00	0.00	35,000.00
01 3300	IN-LIEU OF SCH. LAND TAX	0.00	309.41	2,004.57	0.00	(2,004.57)
01 3500	STATE CATEGORICAL PROGRAMS	9,000.00	0.00	0.00	0.00	9,000.00
01 3510	EDUC INNOVATION FUNDS-Coor School Health	0.00	0.00	0.00	0.00	0.00
01 3512	DISTANCE EDUCATION INCENTIVE PAYMENTS	0.00	0.00	4,000.00	0.00	(4,000.00)
01 3540	EARLY CHILDHOOD	0.00	0.00	0.00	0.00	0.00
01 3990	OTHER STATE RECEIPTS	0.00	0.00	0.00	0.00	0.00
Subtotal: STATE RECEIPTS		299,215.00	40,388.27	65,237.34	21.80	233,977.66
01 4200	TITLE I	149,592.00	0.00	71,933.00	48.09	77,659.00
01 4310	TITLE IIA	12,500.00	0.00	0.00	0.00	12,500.00
01 4315	TITLE II, PART B NCLB	0.00	0.00	0.00	0.00	0.00
01 4320	Innovation Ed Prog(Include NCLB TitleV)	0.00	0.00	0.00	0.00	0.00
01 4404	IDEA BASE	125,000.00	0.00	0.00	0.00	125,000.00
01 4406	IDEA PRESCHOOL(619) BASE ALLOCATION	0.00	0.00	0.00	0.00	0.00
01 4410	IDEA ENROLLMENT/POVERTY	0.00	0.00	0.00	0.00	0.00
01 4450	MEDICAID IN SCHOOLS	10,000.00	1,625.70	3,277.11	32.77	6,722.89
01 4455	MEDICAID ADMIN. ACTIV.	15,000.00	1,625.80	1,625.80	10.84	13,374.20
01 4593	IDEA ENROLLMENT POVERTY	0.00	0.00	0.00	0.00	0.00
01 4599	FED STIMULUS/STATE AID	0.00	0.00	0.00	0.00	0.00
01 4610	ARRA: IDEA PART B(611) ENROLL/POV	0.00	0.00	0.00	0.00	0.00
01 4630	ARRA: IDEA PRESCHOOL(619) ENROLL/POV	0.00	0.00	0.00	0.00	0.00
01 4690	OTHER FEDERAL NON-CATEGORICAL RECEIPTS	22,890.00	0.00	12,278.52	53.64	10,611.48
01 4810	ARRA TITLE I PART D	0.00	0.00	0.00	0.00	0.00
01 4850	UNIVERSAL SERVICE FUND (E-RATE)	0.00	680.00	680.00	0.00	(680.00)
01 4940	HEAD START	0.00	0.00	350.00	0.00	(350.00)
01 4960	DRUG FREE SCHOOLS	0.00	0.00	0.00	0.00	0.00
01 4985	TITLE II PART D	0.00	0.00	0.00	0.00	0.00
01 4990	OTHER FEDERAL CATEGORICAL RECEIPTS	0.00	0.00	3,500.00	0.00	(3,500.00)
01 4992	REAP	26,778.00	0.00	4,645.00	17.35	22,133.00
Subtotal: FEDERAL RECEIPTS		361,760.00	3,931.50	98,289.43	27.17	263,470.57

Regular; Processing Month 12/2015; Fund Number 01

Fund: 01 GENERAL FUND

<u>Account Number</u>	<u>Description</u>	<u>Revised Budget</u>	<u>During Month</u>	<u>To Date</u>	<u>% of Budget</u>	<u>Budget Balance</u>
01 5200	LONG TERM LOANS	0.00	0.00	0.00	0.00	0.00
01 5300	INSURANCE ADJUSTMENTS	0.00	0.00	2,280.46	0.00	(2,280.46)
01 5400	SALE OF PROPERTY	500.00	0.00	0.00	0.00	500.00
01 5500	TRANSFERS FROM FUNDS (INCOMING)	0.00	0.00	0.00	0.00	0.00
01 5690	OTHER NON-REVENUE REC.	0.00	0.00	36.15	0.00	(36.15)
Subtotal: NON-REVENUE RECEIPTS		500.00	0.00	2,316.61	463.32	(1,816.61)
Fund Total:		5,447,475.00	65,649.59	1,433,327.32	26.31	4,014,147.68

Building Fund

December 31, 2015

Balance on hand:	11/30/15	\$6,892.78
Receipts:	Interest	\$0.88
	Misc	\$6.32
Disbursements:		<u>\$0.00</u>
Balance on hand:	12/31/15	\$6,899.98

Reconciliation:		\$6,899.98
FSB Super Now Acct Ckg		\$0.00
less outstanding cks		<u>\$0.00</u>
Recon Total	12/31/15	\$6,899.98

Depreciation Fund

December 31, 2015

Balance on hand:	11/30/15	\$14,501.33
Receipts:		\$0.00
Disbursements:	Claims	<u>(\$5,490.86)</u>
Balance on hand:	12/31/15	\$9,010.47

End Balance \$9,010.47

Reconciliation:		\$9,010.47
FSB Checking		\$9,010.47
plus outstanding dep		\$0.00
less outstanding cks		\$0.00

Recon Total 12/31/15 \$9,010.47

End Balance \$9,010.47

Employee Benefit/Unemployment Ins Fund

December 31, 2015

Balance on hand:	11/30/15	\$3,461.21
Receipts:	Interest	\$0.29
Disbursements:		<u>\$0.00</u>
Balance on hand:	12/31/15	\$3,461.50

	11/30/15	\$3,921.76
	Interest	<u>\$4.45</u>
12/31/15 Investments		<u>\$3,926.21</u>

Recon Total 12/31/15 \$7,387.71

Reconciliation:			Matures	Next Mature
FSB Checking Account		\$3,461.50		
Less Outstanding Ck		\$0.00		
Plus Outstanding Deposits		<u>\$0.00</u>		
	12/31/15			
FSB CD#33386		\$3,926.21	6 Mths	1/1/16
Investment 12/31/15		\$3,926.21		

Recon Total 12/31/15 \$7,387.71

Lunch Fund

December 31, 2015

Balance on hand:	11/30/15	\$37,803.84
Receipts:		
	Meals, milk & juice	\$8,235.10
	Transfer from General Fund	\$0.00
	Fed Reim	\$8,469.78
	State Reim	\$0.00
	Interest Checking	\$5.15
	Misc Deposits AF Reim's to Lunch	\$276.15
	Disbursements	(\$7,708.47)
	Payroll Reim to GF	(\$6,294.98)
	NSF	\$0.00

Balance on hand:	12/31/15	\$40,786.57
-------------------------	-----------------	--------------------

Reconciliation:

FSB	Super Now Acct Ckg	\$40,786.57
	plus outstanding deposits	\$0.00
	less outstanding checks	\$0.00

Recon Total	12/31/15	\$40,786.57
--------------------	-----------------	--------------------

	O/S claims, estimate due	\$0.00
	Payroll Estimates	(\$7,000.00)
	outstanding Receipts	
	Net Estimate Cash Resource	\$33,786.57

Cafeteria Plan

December 31, 2015

Balance on hand:	11/30/15	\$21,743.40
Receipts:	Transfer frm General Fund for 2015-16 SY	
	Reim from Employees Payroll-December	\$1,939.98
	Reim from Employees Non-Qualified Exp	\$0.00
	Debit Card Expense Reimb	\$0.00
Disbursements:	Claims Checks for 2015-2016 SY	(\$2,969.02)
	Claims Checks for 2014-2015 SY	\$0.00
	Reimb GF for 2015-16 Start-up	\$0.00
	Check Supply Order	\$0.00
AMGL & Employees	Non-Qualified fee	\$0.00
	Claims Debit Cards	(\$282.31)
Balance on hand:	12/31/15	\$20,432.05
Reconciliation:		
FSB Checking		\$21,434.54
	less outstanding receipts	\$0.00
	less outstanding chks	(\$1,002.49)
Recon Total	12/31/15	\$20,432.05

Activity Fund

December 31, 2015

Balance on hand:	11/30/15	\$84,363.72
Receipts:	Dep/Interest	\$14,145.18
Disbursements:	November	(\$24,784.69)

Checking Account Balance 12/31/15 \$73,724.21

11/30/15 Investments	\$21,034.60
Interest	\$0.00
12/31/15	\$21,034.60

Total Activity Fund Balance \$94,758.81

Reconciliation:

FSB	Now Acct Ckg	\$75,453.73
	Plus Outstanding Dep	\$0.00
	Less Outstanding Ck	(\$1,729.52)

Recon Total 12/31/15 \$73,724.21

CD #404519 \$21,034.60

Recon Total 12/31/15 \$94,758.81

Regular; Beginning Month 12/2015; Processing Month 12/2015; Active Chart of Account Number True; Fund Number 05

Fund: 05 ACTIVITY FUND

<u>Chart of Account Number</u>	<u>Chart of Account Description</u>	<u>Beginning Balance</u>	<u>Expenses</u>	<u>Revenues</u>	<u>Balance Change</u>	<u>Balance</u>
05 704 0001	ATHLETICS	(2,653.02)	2,318.50	998.00	0.00	(3,973.52)
05 704 0002	CAMPS	5,370.00	0.00	0.00	0.00	5,370.00
05 704 0003	CROSS COUNTRY	541.83	0.00	0.00	0.00	541.83
05 704 0004	BASKETBALL/BOYS	1,025.52	0.00	0.00	0.00	1,025.52
05 704 0005	BASKETBALL/GIRLS	4,701.75	360.00	455.52	0.00	4,797.27
05 704 0006	Football	2,696.60	0.00	0.00	0.00	2,696.60
05 704 0007	GOLF	1,124.10	12.71	(6.67)	0.00	1,104.72
05 704 0008	TRACK/GIRLS	2,287.55	(11.97)	0.00	0.00	2,299.52
05 704 0010	VOLLEYBALL	1,361.48	5.82	0.00	0.00	1,355.66
05 704 0011	WRESTLING	2,292.48	615.00	1,557.00	0.00	3,234.48
05 704 0015	ANNUAL	(3,003.53)	0.00	1,060.00	0.00	(1,943.53)
05 704 0016	BAND	7,612.81	57.83	0.00	0.00	7,554.98
05 704 0017	CHEER SQUAD	13.68	0.00	237.10	0.00	250.78
05 704 0019	CONCESSIONS	(1,348.41)	401.31	816.83	0.00	(932.89)
05 704 0020	FCCLA	2,320.61	560.16	243.96	0.00	2,004.41
05 704 0021	FFA	21,741.53	15,209.23	3,874.80	0.00	10,407.10
05 704 0022	FOREIGN LANGUAGE	2,113.91	0.00	0.00	0.00	2,113.91
05 704 0023	FRESHMAN	382.56	12.71	(20.00)	0.00	349.85
05 704 0024	JUNIORS	2,655.67	761.55	886.87	0.00	2,780.99
05 704 0025	SENIOR BANNERS	0.00	0.00	0.00	0.00	0.00
05 704 0026	NHS	5,838.35	300.02	1,231.00	0.00	6,769.33
05 704 0027	OM/GIFTED	(80.00)	0.00	0.00	0.00	(80.00)
05 704 0028	SCIENCE CLUB	320.10	0.00	0.00	0.00	320.10
05 704 0029	SENIORS	1,188.36	0.00	0.00	0.00	1,188.36
05 704 0030	SOPHMORES	505.11	0.00	0.00	0.00	505.11
05 704 0031	STUDENT COUNCIL	(638.30)	0.00	0.00	0.00	(638.30)
05 704 0032	VOCAL	125.16	23.00	23.00	0.00	125.16
05 704 0034	CAPS/GOWNS	2,759.81	0.00	0.00	0.00	2,759.81
05 704 0037	GREENHOUSE	9,457.98	0.00	487.00	0.00	9,944.98
05 704 0038	COURTESY	2,095.94	89.99	0.00	0.00	2,005.95
05 704 0039	ELEMENTARY TEACHERS	2,005.10	302.00	0.00	0.00	1,703.10
05 704 0040	INDUSTRIAL ARTS	1,387.19	789.13	648.97	0.00	1,247.03
05 704 0041	INVESTMENTS	21,034.60	0.00	0.00	0.00	21,034.60
05 704 0043	LIBRARY	103.99	0.00	0.00	0.00	103.99
05 704 0046	SPECIAL PROJECTS	9,132.81	1,416.27	1,426.80	0.00	9,143.34
05 704 0047	SPEECH/DRAMA	(1,073.76)	1,404.46	0.00	0.00	(2,478.22)
05 704 0048	ENTREPRENEURSHIP	73.86	0.00	0.00	0.00	73.86
05 704 0049	ACE, 40 Dev Assets	(77.00)	0.00	0.00	0.00	(77.00)
05 704 0050	IND ARTS/DONATIONS	169.45	0.00	0.00	0.00	169.45
05 704 0051	QUIZ BOWL	(167.55)	156.97	225.00	0.00	(99.52)
Fund Total: 05		105,398.32	24,784.69	14,145.18	0.00	94,758.81

<u>PO Number</u>	<u>Invoice</u>	<u>Vendor Name</u>	<u>Invoice Date</u>	<u>Amount</u>
<u>Account Number</u>		<u>Description</u>	<u>Amount</u>	
Checking		1		
Checking		1		
	006773-190797	Fund: 01 GENERAL FUND ALMQUIST M.G. & LUTH, P.C.	12/16/2015	149.00
01 2510 660 0		DATA PROCESSING, December Flex	149.00	
		Vendor Total:		149.00
	1096	ALPHA REHABILITATION PC	12/31/2015	888.68
01 4450 313 2		Puch Srvs, PUPIL SERVICES, OT J Riley	22.94	
01 4450 313 2		Puch Srvs, PUPIL SERVICES, SpT J Riley	210.37	
01 4450 313 2		Puch Srvs, PUPIL SERVICES, PT J Riley	31.00	
01 4450 313 2		Puch Srvs, PUPIL SERVICES, OT A Wagner	24.80	
01 4450 313 2		Puch Srvs, PUPIL SERVICES, SP A Wagner	236.87	
01 4450 313 1		Puch Srvs, PUPIL SERVICES, OT B Wagner	152.33	
01 4450 313 1		Puch Srvs, PUPIL SERVICES, SP B Wagner	210.37	
		Vendor Total:		888.68
4846Chad	15929	ASK SUPPLY CO., LLC	12/23/2015	570.20
01 2610 410 0		SUPPLIES, cleaner	570.20	
		Vendor Total:		570.20
	27882	AURORA COOPERATIVE	12/08/2015	4,389.34
01 2750 336 0		GAS & OIL, December	4,389.34	
		Vendor Total:		4,389.34
1215Linea	928618	AUTO WAY BOWL	12/21/2015	162.00
01 1100 419 0		STUDENT FEES/OTHER, 6th Bonham	162.00	
		Vendor Total:		162.00
	20151214	BOETTCHER, HEATHER	12/14/2015	14.00
01 2310 410 0		SUPPLIES, ACE	14.00	
		Vendor Total:		14.00
	53510	CAMELOT TRANSPORTATION INC.	11/02/2015	1,190.00
01 2760 331 0		CONTRACTED PUPIL TRANSPORT, J Riley	1,190.00	
		Vendor Total:		1,190.00
	17910	CAMERA DOCTOR, THE	12/17/2015	85.00
01 1100 338 2		REPAIRS AND MAINTENANCE, camera	85.00	
		Vendor Total:		85.00
	20151224	CHARTER COMMUNICATIONS	12/24/2015	110.01
01 1100 382 2		DISTANCE ED, MBPS Opt Ethr	514.26	

<u>PO Number</u>	<u>Invoice</u>	<u>Vendor Name</u>	<u>Invoice Date</u>	<u>Amount</u>
<u>Account Number</u>		<u>Description</u>	<u>Amount</u>	
01 1100 382 2		DISTANCE ED, NE Univ Srv	35.74	
01 1100 382 2		DISTANCE ED, NE Univ Srv	(28.59)	
01 1100 382 2		DISTANCE ED, Erate 80%	(411.40)	
Vendor Total:				110.01
	20151226	CHASE CARD SERVICES	12/26/2015	193.06
01 2610 410 0		SUPPLIES, cleaning	39.90	
01 2510 690 0		SUPPLIES, Labor Law Posters	77.25	
01 1100 418 2		FCS, sewing mach parts, McDowell	75.91	
Vendor Total:				193.06
	20151231	CITY OF FRANKLN	12/31/2015	7,223.43
01 2610 322 0		ELECTRICITY, 11/15-12/15	6,512.73	
01 2610 323 0		WATER & SEWER, 11/15-12/15	236.70	
01 2610 324 0		GARBAGE DISPOSAL, 11/15- 12/15	474.00	
Vendor Total:				7,223.43
	20151228	CULLIGAN OF KEARNEY	12/28/2015	82.50
01 2610 410 0		SUPPLIES	82.50	
Vendor Total:				82.50
	20151215	DEARBORN NATIONAL LIFE INSURANCE COMPANY	12/15/2016	258.00
01 1100 260 1		LIFE INSURANCE	45.30	
01 1100 260 2		LIFE INSURANCE	98.70	
01 1160 260 1		LIFE INSURANCE	6.00	
01 1190 260 0		LIFE INSURANCE	3.00	
01 1200 260 1		LIFE INSURANCE	15.00	
01 1200 260 2		LIFE INSURANCE	6.00	
01 1310 260 0		LIFE INSURANCE	1.20	
01 2120 260 1		LIFE INSURANCE	3.00	
01 2120 260 2		LIFE INSURANCE	3.00	
01 2222 260 0		LIFE INSURANCE	4.80	
01 2320 260 0		LIFE INSURANCE	18.00	
01 2410 260 1		LIFE INSURANCE	6.00	
01 2410 260 2		LIFE INSURANCE	6.00	
01 2610 260 0		LIFE INSURANCE	18.00	
01 4200 260 0		LIFE INSURANCE	6.00	
01 4310 260 0		LIFE INSURANCE	6.00	
01 4404 260 0		LIFE INSURANCE	3.00	
01 4410 260 1		LIFE INSURANCE	3.00	
01 9001 260 0		LIFE INSURANCE	6.00	
Vendor Total:				258.00
4821Chad-1	20151218	DECKER INC.	12/18/2015	272.31
01 2610 410 0		SUPPLIES, wastebaskets	272.31	
Vendor Total:				272.31

<u>PO Number</u>	<u>Invoice</u>	<u>Vendor Name</u>	<u>Invoice Date</u>	<u>Amount</u>
<u>Account Number</u>		<u>Description</u>	<u>Amount</u>	
	S118609	EAKES INC.	12/28/2015	4,424.18
01 1100 410 1		SUPPLIES, copies	2,212.09	
01 1100 410 2		SUPPLIES, copies	2,212.09	
		Vendor Total:		4,424.18
	20151209	ESU #9	12/09/2015	2,643.61
01 1219 313 2		Purch Serv,PUPIL SERVICES, + 18 Jackson	1,150.28	
01 3540 313 0		Early Chldhd Purch PUPIL SERVICES	1,493.33	
		Vendor Total:		2,643.61
	2763	ESU 11	12/17/2015	39.89
01 1100 413 2		INDUSTRIAL ARTS, 3D printing	39.89	
		Vendor Total:		39.89
	20151231	FRANKLIN AUTO PARTS	01/05/2016	283.44
01 2750 690 0		MISCELLANEOUS, towels, lube, guage	141.66	
01 2750 336 0		GAS & OIL, filters	141.78	
		Vendor Total:		283.44
	20151130	FRANKLIN COUNTY CHRONICLE	11/30/2016	396.82
01 2510 350 0		ADVERTISING/PRINTING, November	396.82	
		Vendor Total:		396.82
	20151221	FRONTIER	12/21/2015	539.67
01 2510 342 0		TELEPHONE, 11/21-12/20	539.67	
		Vendor Total:		539.67
4834Chad-1	108882075	GLOBAL EQUIPMENT CO., INC.	12/10/2015	159.40
01 2610 410 0		SUPPLIES, filters	159.40	
		Vendor Total:		159.40
	20151231	HASTINGS TRIBUNE	12/31/2015	40.00
01 2510 350 0		ADVERTISING/PRINTING, Winter Sports	40.00	
		Vendor Total:		40.00
	20150105	HEAD START CHILD & FAMILY DEVELOPMENT PROGRAM, INC.	01/05/2016	197.24
01 4404 410 0		SUPPLIES, December	197.24	
	20151204	HEAD START CHILD & FAMILY DEVELOPMENT PROGRAM, INC.	12/04/2015	227.92
01 4404 410 0		SUPPLIES, November	227.92	
		Vendor Total:		425.16
	20150131	HOMETOWN LEASING	12/31/2015	1,460.31
01 5000 610 0		REDEMPTION OF PRINCIPAL, copier	1,460.31	
		Vendor Total:		1,460.31

<u>PO Number</u>	<u>Invoice</u>	<u>Vendor Name</u>	<u>Invoice Date</u>	<u>Amount</u>	
<u>Account Number</u>		<u>Description</u>	<u>Amount</u>		
	00164935	HTMC	12/18/2015	85.00	
01 2510 350 0		ADVERTISING/PRINTING, School Board	85.00		
				Vendor Total:	85.00
4818Monica	52641	JAYMAR BUSINESS FORMS, INC	12/29/2015	78.93	
01 2510 660 0		DATA PROCESSING, 1099/1095C	78.93		
				Vendor Total:	78.93
4835Melody	03461551	JW PEPPER & SON INC.	12/14/2015	97.49	
01 1100 412 2		VOCAL MUSIC, Antholz	97.49		
4835Melody-1	03462524	JW PEPPER & SON INC.	12/23/2015	44.00	
01 1100 412 2		VOCAL MUSIC, Antholz	44.00		
				Vendor Total:	141.49
	S101213285.002	KRIZ DAVIS CO	12/14/2015	146.00	
01 2610 410 0		SUPPLIES, clear lens	146.00		
4822chad-1	S101230378.001	KRIZ DAVIS CO	12/21/2015	126.54	
01 2610 410 0		SUPPLIES, manual controller lcking	126.54		
4822chad-rtn	S101230389.001	KRIZ DAVIS CO	12/08/2015	(95.34)	
01 2610 410 0		SUPPLIES, sp toggle return	(95.34)		
				Vendor Total:	177.20
4837Shelley	116736068	MASTER TEACHER, INC., THE	12/17/2015	119.85	
01 2310 690 0		MISCELLANEOUS, G Holmes	119.85		
				Vendor Total:	119.85
	50939508	MATHESON TRI-GAS, INC	12/31/2015	36.66	
01 1100 418 2		Vo Ag, Rocker	18.33		
01 1100 413 2		INDUSTRIAL ARTS, Vetter	18.33		
				Vendor Total:	36.66
	95860	MENARDS, INC.	12/06/2015	375.42	
01 2610 410 0		SUPPLIES, building	375.42		
	96387	MENARDS, INC.	12/13/2015	22.42	
01 2610 410 0		SUPPLIES, building	22.42		
	96702	MENARDS, INC.	12/17/2015	8.09	
01 2610 410 0		SUPPLIES, building	8.09		
	96820	MENARDS, INC.	12/19/2015	330.83	
01 2610 410 0		SUPPLIES, building	330.83		
	97548	MENARDS, INC.	12/30/2015	218.22	
01 2610 410 0		SUPPLIES, building	218.22		
				Vendor Total:	954.98
	20151230	MIDWEST COMMUNICATIONS	12/30/2015	236.00	
01 2620 315 0		ELECTRICAL WORK, annual	236.00		
				Vendor Total:	236.00

<u>PO Number</u>	<u>Invoice</u>	<u>Vendor Name</u>	<u>Invoice Date</u>	<u>Amount</u>
<u>Account Number</u>		<u>Description</u>	<u>Amount</u>	
	51806	MIDWEST CONNECT LLC	12/11/2015	195.00
01 2510 341 0		POSTAGE, meter ink	195.00	
		Vendor Total:		195.00
4845Chad	13530	MIDWEST FLOOR SPECIALISTS, INC	01/05/2016	873.40
01 2610 410 0		SUPPLIES, cleaner/detergent	873.40	
		Vendor Total:		873.40
	22206	MIERAU & CO PC	12/31/2015	350.00
01 2510 660 0		DATA PROCESSING, Dec PR	350.00	
		Vendor Total:		350.00
	AXT1215-JR	MOSAIC	12/31/2015	3,460.38
01 1200 370 2		TUITION PD OTH AGENCIES SPED, J Riley-Oc	823.90	
01 1200 370 2		TUITION PD OTH AGENCIES SPED, J Riley-No	2,636.48	
	AXT1215AW	MOSAIC	12/31/2015	2,636.48
01 4450 370 2		TUITION PD OTH SPED, A Wagner	2,636.48	
	AXT1215BW	MOSAIC	12/31/2015	3,011.89
01 4450 370 1		TUITION OTH AGENCIES SPED, B Wagner	2,966.04	
01 4450 313 1		Puch Srvs, PUPIL SERVICES, OT B Wagner	45.85	
		Vendor Total:		9,108.75
	Emtg2016#49	NETS	12/10/2015	1,500.00
01 2310 630 0		DUES/FEES, Jan-Dec 2016 emeetings	1,500.00	
		Vendor Total:		1,500.00
	77586	OK TIRE STORE	12/03/2015	16.50
01 2760 338 0		VEHICLE REPAIRS, SPED	16.50	
		Vendor Total:		16.50
	2169	PALMER INSTRUMENTAL REPAIR INC.	12/31/2015	125.00
01 1100 411 2		BAND, repairs	125.00	
		Vendor Total:		125.00
	23927	PAULSEN AUTOMOTIVE	12/23/2015	192.00
01 2760 338 0		VEHICLE REPAIRS, 3 inspect	72.00	
01 2750 338 0		VEHICLE REPAIRS, 5 inspect	120.00	
		Vendor Total:		192.00
	67737	PAVELKA TRUCK & TRAILER REPAIR	12/30/2015	4,495.42
01 2750 338 0		VEHICLE REPAIRS, O4 Intl ABS	4,495.42	
		Vendor Total:		4,495.42
	78	PERRY, GUTHERY, HAASE & GESSFORD, PC, LLO	12/20/2015	910.00

<u>PO Number</u>	<u>Invoice</u>	<u>Vendor Name</u>	<u>Invoice Date</u>	<u>Amount</u>	
<u>Account Number</u>		<u>Description</u>	<u>Amount</u>		
01 2330 317 0		LEGAL SERVICES, December	910.00		
				Vendor Total:	910.00
	20151229	PITSTOP & SHOP, INC.	12/29/2015	113.76	
01 2760 336 0		GAS & OIL, December	113.76		
				Vendor Total:	113.76
1142Dave-Dec	20151229	PLANK LUMBER & HARDWARE	12/29/2015	7.96	
01 1100 418 2		Vo Ag, Rocker	7.96		
	20151229-B	PLANK LUMBER & HARDWARE	01/07/2016	183.59	
01 2610 410 0		SUPPLIES, building	183.59		
	20151229-G	PLANK LUMBER & HARDWARE	12/29/2015	3.98	
01 2610 410 0		SUPPLIES, grounds	3.98		
				Vendor Total:	195.53
	20151217	PRINCIPAL LIFE/DEPT. 900	12/17/2015	1,207.55	
01 1100 290 1		DISABILITY INSURANCE	184.29		
01 1100 290 2		DISABILITY INSURANCE	394.60		
01 1160 290 1		DISABILITY INSURANCE	40.13		
01 1200 290 1		DISABILITY INSURANCE	67.95		
01 1200 290 2		DISABILITY INSURANCE	72.57		
01 1190 290 0		DISABILITY INSURANCE	12.32		
01 4404 290 0		DISABILITY INSURANCE	20.55		
01 1310 290 0		DISABILITY INSURANCE	6.31		
01 2120 290 1		DISABILITY INSURANCE	12.99		
01 2120 290 2		DISABILITY INSURANCE	13.00		
01 2130 290 1		DISABILITY INSURANCE	5.12		
01 2130 290 2		DISABILITY INSURANCE	5.11		
01 2222 290 0		DISABILITY INSURANCE	25.23		
01 2320 290 0		DISABILITY INSURANCE	97.76		
01 2410 290 1		DISABILITY INSURANCE	40.54		
01 2410 290 2		DISABILITY INSURANCE	52.12		
01 2610 290 0		DISABILITY INSURANCE	53.66		
01 2760 290 0		DISABILITY INSURANCE	6.55		
01 4200 290 0		DISABILITY INSURANCE	31.05		
01 4310 290 0		DISABILITY INSURANCE	25.10		
01 4410 290 1		DISABILITY INSURANCE	12.41		
01 9001 290 0		DISABILITY INSURANCE	28.19		
				Vendor Total:	1,207.55
1008Becky-Dec	20151229-1	RIGHTWAY INC.	12/29/2015	31.77	
01 1100 410 2		SUPPLIES, Cleveland	31.77		
1103Shannett e-D	20151229-2	RIGHTWAY INC.	12/29/2015	4.28	
01 1100 410 2		SUPPLIES, Kahrs	4.28		
1150Kathy-Dec	20151229-3	RIGHTWAY INC.	12/29/2015	33.59	
01 1100 410 2		SUPPLIES, Schmidt	33.59		
1132Theresa-	20151229-372	RIGHTWAY INC.	12/29/2015	124.99	

<u>PO Number</u>	<u>Invoice</u>	<u>Vendor Name</u>	<u>Invoice Date</u>	<u>Amount</u>
<u>Account Number</u>		<u>Description</u>	<u>Amount</u>	
Dec				
01 1100 418 2		FCS, McDowell	124.99	
1200Lacey- Dec	20151229-4	RIGHTWAY INC.	12/29/2015	10.96
01 1100 410 1		SUPPLIES, L Hoffman	10.96	
	20151229G	RIGHTWAY INC.	12/29/2015	1,130.37
01 2610 410 0		SUPPLIES, grounds	261.81	
01 2610 410 0		SUPPLIES, building	836.66	
01 2310 690 0		MISC, Staff Christmas	31.90	
		Vendor Total:		1,335.96
	2015Nov-Dec	RILEY, THOMAS	12/31/2015	340.00
01 2760 332 0		MILEAGE TO PARENTS, J Riley	340.00	
		Vendor Total:		340.00
	20151231	S.E. SMITH & SONS	12/31/2015	257.07
01 2610 410 0		SUPPLIES, building	257.07	
		Vendor Total:		257.07
4843Angie	208115652621	SCHOOL SPECIALTY	12/18/2015	67.64
01 1100 410 1		SUPPLIES, laminator	33.82	
01 1100 410 2		SUPPLIES, laminator	33.82	
		Vendor Total:		67.64
	20151226	Schutz, Jennifer	12/26/2015	215.49
01 1218 313 2		Purch Serv,PUPIL SERVICES, OT Ignowski	215.49	
		Vendor Total:		215.49
	201448140189	SOURCE GAS	12/30/2015	578.81
01 2610 321 0		FUEL/NATURAL GAS, 12/1- 12/30	578.81	
	201626100093	SOURCE GAS	12/30/2015	3,374.10
01 2610 321 0		FUEL/NATURAL GAS, 12/1- 12/30	3,374.10	
	201626100094	SOURCE GAS	12/30/2015	346.22
01 2610 321 0		FUEL/NATURAL GAS, 12/1- 12/30	346.22	
		Vendor Total:		4,299.13
4833Chad	72951840	ULINE, INC.	12/10/2015	628.05
01 2610 410 0		SUPPLIES, boot scraper/trash cans	628.05	
4848Chad	73198402	ULINE, INC.	12/18/2015	161.72
01 2610 410 0		SUPPLIES, boot scraper/trash cans	161.72	
		Vendor Total:		789.77
	06056384	VERIZON BUSINESS	12/25/2015	173.60
01 2510 342 0		TELEPHONE, 11/15-12/14	173.60	
		Vendor Total:		173.60

<u>PO Number</u>	<u>Invoice</u>	<u>Vendor Name</u>	<u>Invoice Date</u>	<u>Amount</u>
<u>Account Number</u>		<u>Description</u>	<u>Amount</u>	
01 2510 342 0	9757793862	VERIZON WIRELESS	12/23/2015	186.57
		TELEPHONE, 11/24-12/23	186.57	
		Vendor Total:		186.57
01 2750 336 0	20151231	WEX BANK	12/31/2015	1,027.95
01 2760 336 0		GAS & OIL, December	562.28	
		GAS & OIL, December	465.67	
		Vendor Total:		1,027.95
01 2510 690 0	NO8647-1841	WOODWARD'S DISPOSAL SERV INC	12/22/2015	47.50
		MISCELLANEOUS, December	47.50	
		Vendor Total:		47.50
		Fund Total:		55,853.71
		Checking Account Total:		55,853.71

Franklin Public Schools
Board of Education
District 506
Franklin, Nebraska 68939

Regular January Meeting

**Monday – January 11th, 2016
7:00 Regular Meeting**

**Franklin Public Schools
Media Center
1001 M Street
Franklin, NE 68939**

Bills Committee: December & January (Scott & Kim)

Uline - \$2123.54 – Depreciation – Locker Room Benches



1-800-295-5510

uline.com

PO Box 88741 • Chicago IL 60680-1741

INVOICE NO.

73244265

**

SHIPPING SUPPLY SPECIALISTS

INVOICE

ULINE FED ID#: 36-3684738

THANK YOU FOR YOUR ORDER. ULINE CUSTOMER SINCE 2014

YOUR ORDER # 77329008

Dep

SOLD TO:

SHIP TO:

MDG2014 00015845 1 MB 0439 10303797



FRANKLIN PUBLIC SCHOOLS
1001 M ST
FRANKLIN NE 68939-1120

FRANKLIN PUBLIC SCHOOLS
1001 M ST
FRANKLIN NE 68939-1120

U100-9-2013

CUSTOMER NO.	PURCHASE ORDER NO.	SHIP VIA	ORDER DATE	DATE SHIPPED	TERMS	INVOICE DATE
10303797	4841CHAD	CONWAY FRT	12/16/15	12/20/15	NET 30 DAYS	12/21/15

QUANTITY			ITEM NUMBER	DESCRIPTION	UNIT PRICE	EXTENDED PRICE
ORDERED	U/M	BACK ORDERED				
3	EA		H-2295BL	6' BENCH WITHOUT BACK - BLACK SHIPPING CHG AMT 132.66	212.00	636.00
4	EA		H-3503BL	8' BENCH WITHOUT BACK - BLACK	292.00	1168.00

ORDER PLACED BY: CHAD SCHMIDT

AORTIZ /C

SUB-TOTAL	SALES TAX	FRT/HNDLING	AMOUNT DUE
1804.00	19.50	300.04	2104.04 2123.54

PLEASE PAY FROM THIS INVOICE REFER TO THIS INVOICE NUMBER WHEN CONTACTING US REGARDING THIS TRANSACTION.

CUSTOMER NAME	CUSTOMER NUMBER	INVOICE NUMBER	INVOICE DATE	AMOUNT DUE
FRANKLIN PUBLIC SCHOOLS	10303797	73244265	12/21/15	2123.54 2104.04

AMOUNT ENCLOSED IF DIFFERENT THAN AMOUNT DUE \$
EXPLAIN DIFFERENCES ON REVERSE SIDE



MAKE CHECK PAYABLE AND MAIL TO:

ULINE
ATTN: ACCOUNTS RECEIVABLE
PO BOX 88741
CHICAGO IL 60680-1741

IMPORTANT - PLEASE DETACH AND RETURN THIS PORTION TO INSURE PROPER CREDIT

1030379700732442651512210002123547

nnnnnn 01 01 015845 017550P

Mail

COMPOSE

Inbox (900)

Starred

Sent Mail

Drafts (2)

More

John Werner BEV AIRE SM49N-W 12 CASE M 1:21 PM (2 hours ago)

Candace Conradt Could you send a quote for a 16 ca 2:06 PM (1 hour ago)

John Werner 3:19 PM (17 minutes ago)

to me

BEV AIRE SM58N-W 16 CASE MILK COOLER UNIT COST \$2,117.00
FREIGHT INCLUDED



Click here to [Reply](#) or [Forward](#)

using 0.92 GB
of storage

[Program Policies](#)

Powered by

Last account activity: 20 minutes ago
[Detail:](#)

sales@leesrefrigeration.com

Mail

Move to Inbox

COMPOSE

Inbox (910)

Starred

Sent Mail

Drafts

More

to sales

Thanks in advance for the quotes.

John Werner <john@leesrefrigera to me

Jan 5 (1 day ago)

BEV AIRE SM49N-W 12 CASE MILE COOLER
WHITE EXTERIOR, SINGLE SIDE ACCESS

UNIT COST \$1,949.00 FREIGHT INCLUDED

CURRENTLY IN STOCK AT FACTORY IN S.C.
ESTIMATED LEAD TIME 5 DAYS

SEE ATTACHED SPEC
LET ME KNOW IF YOU HAVE ANY QUESTIONS. THANKS JOHN

Item No. _____
Quantity _____



BEVERAGE-AIR
1975 Reynolds Blvd., Winston-Salem, NC 27157
Call Toll Free 1-800-845-5551
1400 New Rivergate Dr. Winston-Salem, NC 27157

Commercial Refrigeration Equipment
General Specification

SCHOOL MILK COOLERS
24" DEEP

MODEL:
SM49N
SM49W

3 Year Parts/Labor Warranty
Additional 3 Year Comprehensive Warranty

SEE SPECIFICATIONS FOR COMPLETE DETAILS
SPECIFICATIONS AND UNIT CAPACITY ARE SUBJECT TO CHANGE WITHOUT NOTICE.
© 1999 BEVERAGE-AIR. ALL RIGHTS RESERVED.



BEVERAGE-AIR



BEVERAGE-AIR

3779 Champion Blvd., Winston-Salem, NC 27105
1-888-845-9800 Fax# 1-336-245-6453
http://www.Beverage-Air.com

Item No. _____

Quantity _____

Commercial Refrigeration Equipment General Specification

SCHOOL MILK COOLERS SM SERIES

MODELS:
SM34N
SM49N
SM58N

3 Year Parts/Labor Warranty Additional 2 Year Compressor Warranty

SM SERIES—SINGLE ACCESS, COLD WALL

Single access, cold wall milk coolers are designed to hold milk between 36°F and 38°F until ready to serve. Produced in three sizes to hold 8, 12, and 16 milk cases (13" x 13" x 11") per unit.

CABINET CONSTRUCTION

Standard SM models include lids, doors, adjustable hinges, and door latches made from stainless steel. Balance of exterior is white finish on steel. One-piece, reinforced stainless steel floor for maximum milk crate support. Balance of interior is galvanized steel. Heavy-duty, epoxy coated steel wire floor racks are provided for added floor protection. Floor drain is centrally located for easy cleaning, connecting to drain hose with hose adapter.

Exterior thermometer, cylinder lock, bottom drain, and 4" swivel casters (2 with locks) are provided as standard.

Foamed-in-place CFC and HCFC-free polyurethane insulation enhances the structural strength of the cabinet and helps increase energy efficiency. This insulation helps to prevent liquid penetration that results in foul odors. Overall depth of 31" allows easy mobility and clear passage through most doorways.

Models are also offered with stainless steel exterior in place of white finish on steel. A stainless steel interior is optionally available. Additional options include wrap around and corner bumpers.

REFRIGERATION

Refrigeration system uses R404A refrigerant, which is CFC and HCFC-free for compliance with environmental safety concerns.

ELECTRICAL

Units wired at factory and ready for connection to a 115/60/1 phase, 15 amp dedicated outlet. 8' long cord and plug set included.

SPECIAL FEATURES

- One-piece, reinforced stainless steel floor for maximum support of milk crates.
- SM models have earned the ENERGY STAR®.
- Stainless options available.



SM34N (white exterior shown)

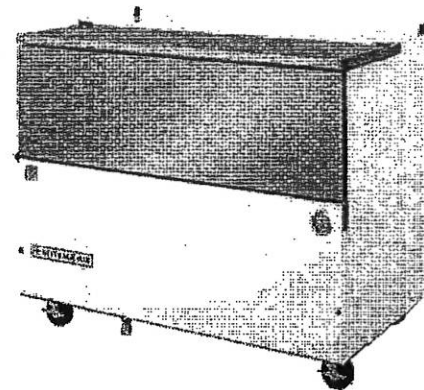

SM49N (white exterior shown)

ELECTRICAL CONNECTION



115/60/1
NEMA-5-15P

Units pre-wired at factory and include 8' long cord and plug set.



*Note: Not all markings

may apply to all

Available From:

Model Specified _____	Store# _____
Location _____	Quantity _____



BEVERAGE-AIR

SM SERIES School Milk Coolers
Models: SM34N, SM49N, SM58N

MODEL	SM34N	SM49N	SM58N
EXTERNAL DIMENSIONAL DATA			
Length Overall (inches)	34 1/2"	49 1/2"	58 1/2"
Length Overall (mm)	878	1257	1486
Depth Overall (inches)	31"	31"	31"
Depth Overall (mm)	787	787	787
Height Overall—(inches)	39 1/2"	39 1/2"	39 1/2"
Height Overall—(mm)	1003	1003	1003
Number of doors/lids	Single/Access	Single/Access	Single/Access
INTERNAL DIMENSIONAL DATA			
NET Capacity (cubic ft.)	13.6	20	24
NET Capacity (Liters)	385	566	679
CASE CAPACITIES			
13" x 13" x 11"	8	12	16
19" x 13" x 11"	4	8	10
ELECTRICAL DATA			
Full Load Amperes 115/60/1	4	7.5	7.5
ENERGY CONSUMPTION (KWH)	2	1.8	2.25
REFRIGERATION DATA			
Horsepower	1/4	1/4	1/3
WEIGHT DATA			
Gross Weight (Crated lbs)	277	339	376
Gross Weight (Crated kg)	126	154	171

PLAN VIEWS

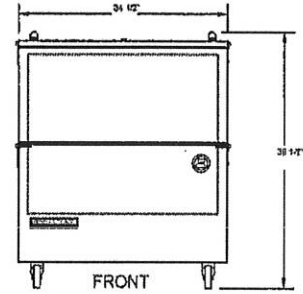

FRONT

SM34N

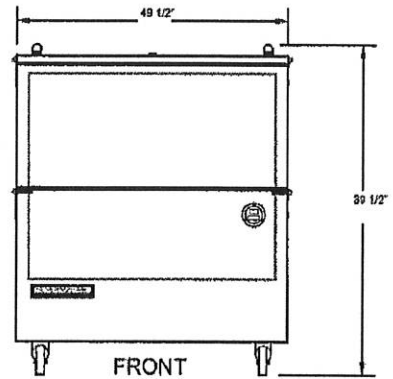

FRONT

SM49N

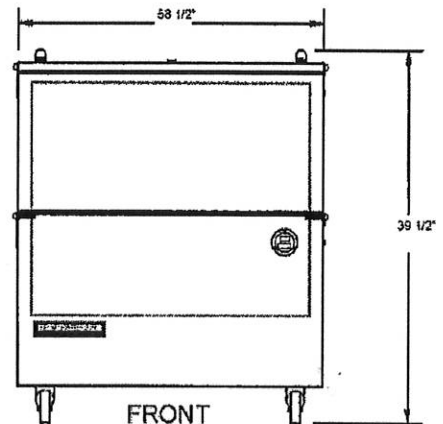

FRONT

SM58N

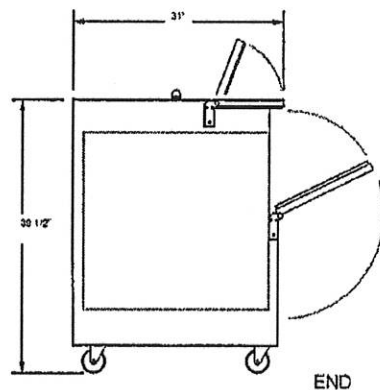

END



*Note: Not all markings may apply to all model variations.

ELECTRICAL CONNECTION

Units pre-wired at factory and include 8' long cord and plug set.



BEVERAGE-AIR® CORPORATION

3779 Champion Blvd. • Winston-Salem, NC 27105 USA • (336) 245-6400 • Fax (336) 245-6453 • (888) 845-9800 • www.beverage-air.com
 Specifications are subject to change without prior notice. 08/13

Business OperationsProcedures—Bidding Construction Projects

The District shall bid every project for the construction, remodeling, or repair of any school-owned building or for site improvements when the contemplated expenditures for the project is in excess of \$100,000.00, or such sum as adjusted pursuant to §73-106. The bidding procedures shall comply with the requirements of state law and shall include the following:

1. Notice to Bidders: The Administration shall prepare a notice to bidders containing a general description of the scope of the project being bid; the location of the project; the means of obtaining project documents, including plans and specifications; the date and hour bids will close; and the date, hour and place bids are to be returned, received and opened, and a provision that such bids will be immediately and simultaneously opened in the presence of the bidders or representatives of the bidders, when the hour is reached for the bids to close.
2. Regular Manner of Advertisement for Bids: The notice to bidders shall be published one time in a newspaper of general circulation in the School District. The notice shall be published at least seven (7) days prior to the date designated for the opening of such bids. The Board of Education or Administration may, in its sole discretion, elect to utilize further advertisement for bids as it may determine appropriate to secure a sufficient number of qualified bidders for the scope of the project.
3. Bid Opening: When the hour is reached for such bids to close, bids will be immediately and simultaneously opened in the presence of the bidders or representatives of the bidders.
4. Contract Award: The contract shall be awarded to the lowest responsible bidder as to the extent required by law. When not so required, the award shall be made on the basis of consideration of the contract award criteria determined appropriate by the Board or administration.
5. Performance and Payment Bonds. Whenever any contract is entered into for the erecting, furnishing, or repairing of any building or other public structure or improvement, the contractor shall be required, before commencing such work, to furnish a performance, labor and material payment bond. The bond requirement shall not apply, however, to any project bid or proposed which has a total cost of \$10,000 or less unless the School Board or Administration includes a bond requirement in the specifications for the project. The bond shall be in an amount not less than the contract price. The bond shall be conditioned on the faithful performance of the contract and the payment by the contracting party of all laborers and mechanics for labor that is performed and of all material and equipment rental that is actually used or rented in connection with the improvement project and the performance of the contract. Such bond shall contain such provisions as are required by statutes, and be in a form prescribed and required by the district.

6. Retention of an Architect or Engineer. The School District shall not engage in the construction of any public works involving architecture or engineering unless the plans, specifications, and estimates have been prepared and the construction has been observed by an architect, a professional engineer, or a person under the direct supervision of an architect, professional engineer, or those under the direct supervision of an architect or professional engineer; provided that such requirement shall not apply to any public work in which the contemplated expenditure for the complete project does not exceed one hundred thousand dollars (\$100,000), as adjusted from time to time by § 81-3445 or other applicable law.

7. Additional Procedures. Each bid for which a labor and material bond is required shall be accompanied by a bid bond or certified check in the amount of five percent (5%) of such bid unless the School Board or Administration waives such requirement. The Board of Education or Administration may provide for additional procedures for the procurement, opening and acceptance of bids as deemed appropriate for a particular project.

Legal Reference: Neb. Rev. Stat. ' 52-118; Neb. Rev. Stat. ' 73-101 *et seq.*; Neb. Rev. Stat. ' 73-106; Neb. Rev. Stat. ' 81-3445

Date of Adoption: November 9, 2015

Springer Roofing Inc.

**804 E 15th St
Kearney, NE 68847**

Phone 308-237-4498 Fax 308-237-5274

Estimate-Proposal

Date	Estimate #
12/17/2015	4638

Proposal Submitted To:

FRANKLIN PUBLIC SCHOOLS
1001 M ST
FRANKLIN NE 68939

Phone 402-746-4036 CELL
Cell
Contact

Project/Job Name
'15---TPO-

Specifications and Estimate for:	Proposed Total
<p>ESTIMATE IS FOR THE 2 SMALL HAIL DAMAGED ROOF SECTIONS ON THE SCHOOL</p> <p>GAF 15YR RHINO-BOND TPO ROOF SYSTEM GAF RHINO-BOND ATTACHED 60MIL TPO SYSTEM</p> <p>ROOFING: . INSTALL LAYER OF 1/2" FIBERBOARD INSULATION OVER ENTIRE DECK. . RHINO BOND 1 LAYER OF 60MIL, ENERGY STAR RATED TPO OVER ENTIRE ROOF TO SYSTEM SPECS. . HEAT WELD ALL SEAMS WITH ROBOTIC WELDER USING THE RHINO-BOND SYSTEM.</p> <p>FLASHING: . FLASH ALL CURBS, WALLS, PIPES & OPENINGS WITH 60MIL TPO. . INSTALL TERMINATION BAR ON WALLS AS NECESSARY. FIFTEEN (15)YR ROOF SYSTEM GUARANTEE.</p> <p>*GAF DIAMOND PLEDGE 15YR NDL (NO DOLLAR LIMIT) EDGE TO EDGE WARRANTY* ROOF WILL BE INSPECTED BY A GAF REPRESENTATIVE. AFTER APPROVAL, A FORMAL 15YR NDL SYSTEM & LABOR WARRANTY WILL BE ISSUED FROM THE SYSTEM'S MANUFACTURER.....ADD.....\$950.00</p> <p>** ANY WET INSULATION FOUND WILL BE REPLACED AT AN ADDITIONAL \$1.15 CENTS PER SQ/FT PER 1" LAYER OF INSULATION.</p> <p>** OWNER TO BE RESPONSIBLE FOR ANY DIS-CONNECTION/RE-CONNECTION OF ELECTRICAL OR UNIT WORK</p>	<p>17,946.00</p>
<p>We Propose to hereby furnish material and labor--complete in ccordance with the above specifications, for the sum of:</p>	<p>Proposed Total</p> <p>\$17,946.00</p>

All material is guaranteed to be as specified. All Work to be completed in a workmanlike manner according to standard practices. All alteration or deviation from the above specifications involving extra cost will be executed only upon written or agreed upon verbal orders, and will become an extra charge over and above the estimates. All agreements contingent upon strikes, accidents, or delays beyond our control. Owner to carry fire, tornado and other necessary insurance. Our workers are fully covered by Workman's Compensation Insurance. Due to pricing volatility, all vender price increases will be passed through at the time we receive them.

Authorized Signature: _____

Note: This proposal may be withdrawn by us if not accepted within _____ days.

Acceptance of Proposal: The above prices, specifications and conditions are satisfactory and are hereby accepted. You are authorized to do the work as specified.

Signature: _____

Date Accepted: _____

Roof Repair



Visit us at: www.springerroofing.com

Magnum Builders

17207 Harney St
Omaha, NE 68118



PROPOSAL

PROPOSAL # 1026
DATE 12/29/2015

ADDRESS
Franklin Public School
1001 M Street
Franklin, NE 68939

Please detach top portion and return with your payment.

DESCRIPTION	QTY	RATE	AMOUNT
Job Location Areas A, B and C (14,140 sq ft) (remainder of lower roof)	1	0.00	0.00
Metal roof with steel framework Build a steel framework over existing roof and install standing seam galvalume roof panels to cover.	1	155,000.00	155,000.00
Flashing Flashing, wall panels, gutter and downspouts to be lightstone color. (included)	1	0.00	0.00
Warranty Includes manufacturers 25 year warranty on steel and Magnum Builders 20 year weather tight warranty.	1	0.00	0.00
Payment Terms 20% down payment when work is scheduled, balance due within 15 days of completion. Interest charges accrue beginning 16 days after invoice date.	1	0.00	0.00

All material is guaranteed to be as specified. All work to be completed in a workmanlike manner according to standard practices. Any changes or additions to the above specifications will be executed only by written change order and will incur additional cost. All agreements are contingent upon strikes, accidents or delays beyond our control.

TOTAL **\$155,000.00**



Accepted By

P = PHANAPST
B" 10' x 32" H.

Area "A" = ~~\$75,000~~
Area "B" = ~~\$20,000~~
Area "C" = ~~\$69,000~~
\$155,000

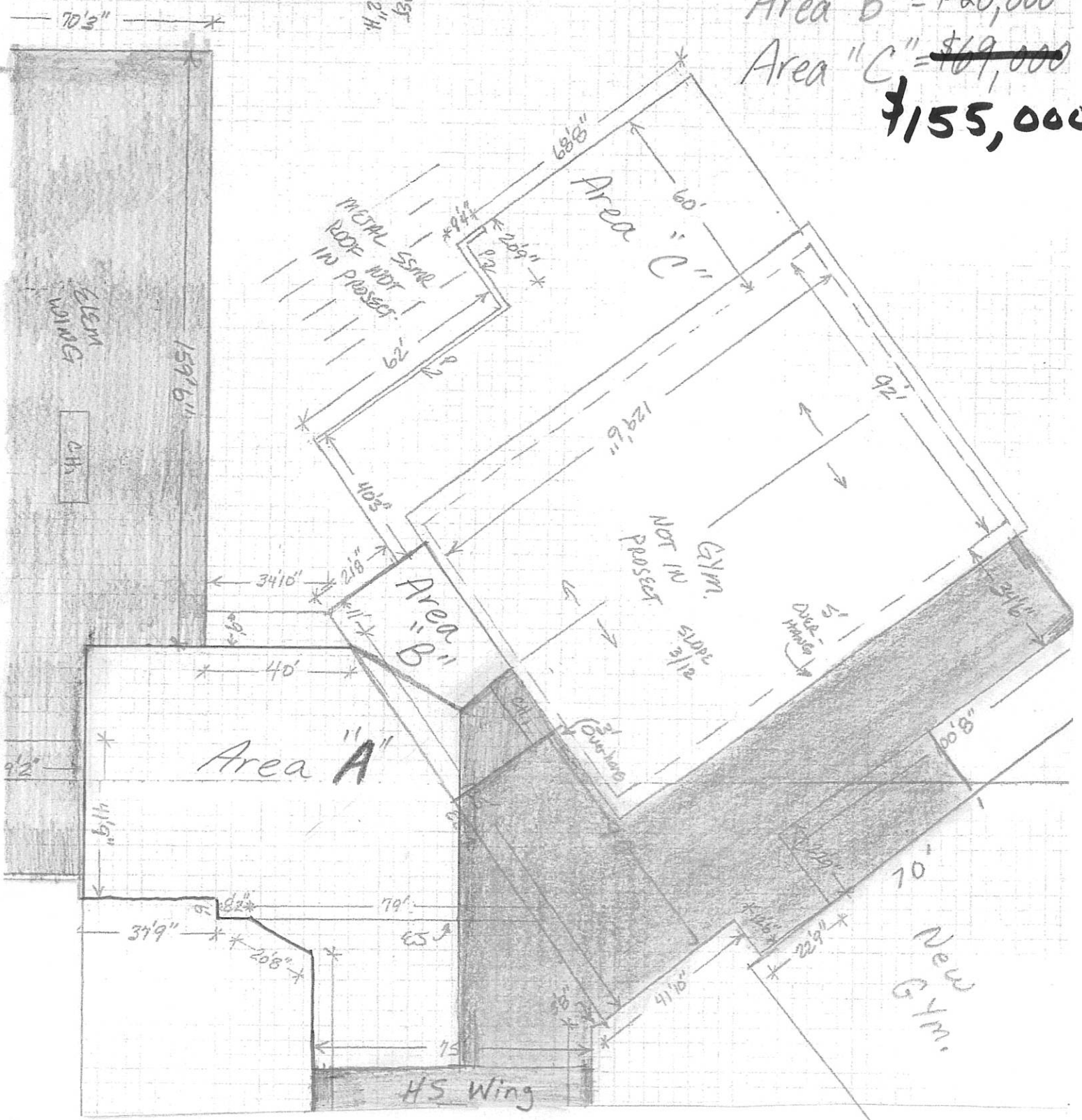

From: Magnum Builders
To: Ken Schroeder



Financing Options

Qualified Capital Purpose Undertaking Fund Bonds (QCPUF)

- Limited Tax Building Improvement Bonds
- Authorized under Nebraska State Statute 79-10,110:

Max Term: 10 Levy Years

Authority: Majority vote of the Board of Education

Max Levy: 5.2 cents per \$100 of taxable valuation

Public Hearing: NONE

Qualifying Projects: Environmental hazard, accessibility barrier exists, life safety code violation, indoor air quality and mold abatement and prevention.

Exempt from Levy Limitation

Qualified Capital Purpose Undertaking Fund (QCPUF)

Facility Improvement Measures:

- Energy Conservation Measure Projects
- Lighting Upgrade Retrofits
- Roof Replacement
- Mold Abatement
- HVAC Retrofits
- Temperature Control Upgrades
- In Door Air Quality (IAQ) Projects • Adding of A/C
- Adding Fresh Air / Ventilation
- Mechanical Retrofit Projects
- Security & Life Safety Projects
- Window Upgrade Retrofits
- Fire Alarm, Building Codes & Life Safety Projects
- Accessibility Barrier Exists
- Environmental Hazard

Affordable Care Act

- Any organization that has 50 or more employees must follow the rules.
- Full Time employees must be offered single insurance. They are not required to take the insurance.
- Full Time Employee is an employee who is works at least 30 hours per week.
- Fifteen (15) of our classified employees fall into this category would be eligible to take the insurance.
- The lowest cost single insurance offered is priced at \$401.09/month. Their cost would be \$93.18/month (poverty level % cost). The district would pay the balance of \$307.91/month. The cost to the district for a full year of single insurance for each employee would be \$3,694.92. If all 15 eligible employees took the insurance the total cost to the district would be \$55,423.80. The above figures are based on the 2016/17 premiums for a \$4,000 Deductible.
- Reasons to offer the insurance:
 - Avoid being penalized by the government
 - It is the moral thing to do for our employees
 - Hiring more qualified part time employees is nearly impossible
 - Most schools are offering the insurance

**Elementary Principal's Report
January 11, 2016**

Math Curriculum Guides

The Elementary teaching staff are in the process of creating new Math Curriculum Guides. The guides are established to communicate the following questions:

What do we want students to learn?

- Identify the essential standards at each grade level which have become our objectives for the lesson.

How will we know that they have learned it?

- created formative assessments and proficiency scales that allow teachers to assess student learning.

How will we respond when the don't know it?

- the proficiency scales provide a communication tool for students to evaluate their own learning.

- it allows for teachers to provide direct intervention to the student of the skill not learned.

How will we respond when they know it?

- the scales provide an opportunity for students to expand their knowledge and application level of the skill to enrich learning.

The math curriculum guides should be completed by the end of the school year. I have provided a sample of a proficiency scale for you to look at.

The Zones of Regulations

As Mrs. Simmons and the elementary classroom teachers continue teaching lessons about The Zones of Regulations we continue to add more support materials in the classroom for students and at recess. I will share the "talking point" materials we are using with students at the meeting. These tools allows for all staff to use the same language when addressing behaviors with students.

Upcoming Events

The honors ceremony is scheduled for the 13th of January. Our annual St. Jude's Math-A-Thon started on January 6th and will run through January 20th.

High School Principal's Report - January 2016
Board of Education

1. Academic Information

- ✓ January 4th In-Service - We focused on defining our curriculums and working with the ideals we have learned from both our Marzano training as well as our PLC training. Staff was guided on four essential questions for each of their classes:
 - o What is it that we want students to learn?
 - o How do we know that students have learned it?
 - o How do we respond when students haven't learned it?
 - o How do we respond when students already know it?

2. Activity Information

- ✓ NSAA Meeting and a vote on a new Transgender Policy - See attached information. I need guidance on how you would like Franklin Public Schools to vote on this major issue facing the state as well as our nation as a whole.

3. Other Information

- ✓ None this month

Nebraska School Activities Association – Gender Participation Policy

The Nebraska School Activities Association (NSAA) has developed this policy to address the eligibility and participation of students in NSAA-sponsored athletics based upon gender.

A. Purpose: The NSAA has as one of its central purposes the fostering and maintenance of a level playing field for the students competing in the activity programs of member high schools. The NSAA's rules-making process involves educators who are specialists in the field of fostering, promoting and caring for the safety and best interests of students, and assuring that students participating in school activities are provided a fair chance to participate in a manner that enhances their education. The principle of competitive equity and the maintenance of a level playing field, and the safety and preservation of the personal privacy interests of student athletes are basic values of schools, and our society as a whole, and is clearly a "substantial interest"¹ of activity associations. To such end, this Gender Participation Policy seeks to balance the important goals of:

- Equal Opportunity: Providing equal opportunities in all aspects of school programming for all students is a core value in education.
- Physical Safety of Student: Protecting the health and safety of all students by assuring that female students are protected from physical injury as a result of participation in activities with biological males or androgen-supplemented biological females who are generally stronger and faster than biological females²; and,
- Competitive Equity: Maintaining a "level playing field" is an inherent expectation at all levels of sport competition and a key value of the schools that are members of the NSAA. Maintaining such competitive equity in NSAA-sponsored activities is indispensable in:
 - Preserving Title IX protections for female activities;³ and,
 - Preserving protections of female athletic activities through the contact sport exclusion to Title IX.⁴
- Personal Privacy: Protecting the personal privacy of all student athletes participating in NSAA activities.⁵

¹ See *Clark v. Arizona Interscholastic Asso.*, 695 F.2d 1126, 1131 (9th Cir. Ariz. 1982); citing *Petrie*, 75 Ill.App.3d at 989, 394 N.E.2d at 862 (Redressing past discrimination against women in athletics is a legitimate and important government interest); Neb. Rev. Stat. § 79-2,104; Family Educational Rights and Privacy Act (FERPA), 20 U.S.C. §1232g; *Johnston v. University of Pittsburgh*, 2015 U.S. Dist. LEXIS 41823, (U.S. Dist. Court, Western District of Penn.), March 31, 2015.

² See *Clark v. Arizona Interscholastic Asso.*, *Supra* at 1131; *Kahn v. Shevin*, 416 U.S. at 355, 94 S. Ct. at 1737, 40 L. Ed. 2d at 193; *Michael M. v. Sonoma County Superior Court*, 450 U.S. at 469, 101 S. Ct. at 1204, 67 L. Ed. 2d at 442; *Orr v. Orr*, 440 U.S. 268, 280-82, 99 S. Ct. 1102, 1112-13, 59 L. Ed. 2d 306, 319-21 (1979)(The court has recognized average real differences between the sexes).

³ ARTICLE: The Title IX Athletic Regulations and the Ideal of a Gender-free Society, 11 U. Denv. Sports & Ent. Law J. 3, 36. citing *O'Connor v. Board of Education*, 645 F.2d 578 (7th Cir. Ill. 1981).

⁴ *Springs Exempted Village School Dist. Bd. of Education v. Ohio High School Athletic Asso.*, 647 F.2d 651 (6th Cir. Ohio 1981).

⁵ See *Johnston v. University of Pittsburgh*, 2015 U.S. Dist. LEXIS 41823, (U.S. Dist. Court, Western District of

B. Definitions: The following definitions apply to this policy:

1. "Gender" means the state of being male or female.
2. "Transgender" means having a gender identity or gender expression that differs from societal expectations based on gender assigned at birth.
 - a. Female-to-Male (FTM) transgender person means one who was born with a female body but who identifies as a boy or man.
 - b. Male-to-Female (MTF) transgender person means one who was born with a male body but who identifies as a girl or woman.
3. "Gender identity" means an innate sense of one's own gender.
4. "Gender expression" means external appearance, characteristics or behaviors typically associated with a specific gender.

C. Gender Based Participation:

1. **Gender Eligibility:** A student's gender for purposes of eligibility for NSAA-sponsored athletic activities shall be determined by the sex noted on the student's birth certificate.⁶

2. **Cross-Gender Participation:** Girls may participate on boys' teams when there is no girls sport or comparable sport (e.g., softball and baseball) or team offered in that sport by the member school. Boys are not allowed to play girls sports or on girls teams even when there is no corresponding boys sport.⁷

D. Transgender Student Participation: The NSAA Gender Participation Policy only addresses bona fide transgender students and does not alter the foregoing cross-gender participation rule.

1. **Privacy Statement:** As stated under the "Purpose" section of this policy, it is a fundamental tenant of the NSAA to protect the personal privacy of all student athletes participating in NSAA activities. Pursuant to such Purpose, protecting the privacy of transgender student athletes must be a priority for all athletic departments and affiliated school personnel. Information regarding a student's transgender status, legal name, or gender assignment at birth may constitute medical information. All medical information

Penn.), March 31, 2015; and, *Grimm v. Gloucester County School Board*, 2015 U.S. Dist. LEXIS 124905 U.S. Dist. Court, Eastern District of Virginia), September 17, 2015.

⁶ Neb. Rev. Stat. § 71-604.01 (2005). "Upon receipt of a notarized affidavit from the physician that performed sex reassignment surgery on an individual born in this state and a certified copy of an order of a court of competent jurisdiction changing the name of such person, the Department of Health and Human Services Finance and Support shall prepare a new certificate of birth in the new name and sex of such person in substantially the same form as that used for other live births. The evidence from which the new certificate is prepared and the original certificate of birth shall be available for inspection only upon the order of a court of competent jurisdiction."

⁷ *Saint v. Nebraska School Activities Association*, 684 F. Supp. 626 (1988), holding that the NSAA was restrained from refusing to permit female student from wrestling on boys' wrestling team.

shall be kept confidential in accordance with applicable state, local and federal privacy laws. All discussions and documentation at each level of the process by the member school, Gender Identity Eligibility Committee and the NSAA shall be kept confidential unless the student and family make a specific request otherwise.

2. Procedures: The following procedures shall apply to participation by a transgender student in NSAA activities:

a. Notice to the School: The student and/or parent shall contact the member school administrator or athletic director, in writing, indicating that the student is a transgender individual, having a consistent gender identity different than the sex on the student's birth certificate, and list the NSAA sport(s) in which the student would like to participate.

b. Member School Determination: The member school shall determine if the student meets the activity eligibility standards for participation established by the NSAA and whether the student meets the requirements of participation established by the member school.

c. Application for Participation to the NSAA: Upon receipt of notice from the transgender student and/or parent of a transgender student wishing to participate in interscholastic sports in a manner consistent with his/her gender identity, the member school, if the member school determines that the student meets the requirements for initial eligibility under standards of participation established by the member school, shall file an application for participation in NSAA activities by the transgender student (Transgender Student Application) on a form provided by the NSAA, providing the information required by this policy. The member school shall be responsible to pay all costs related to the Transgender Student Application, ~~including the costs of the NSAA Gender Identity Eligibility Committee.~~

d. Review and Required Approval by NSAA Gender Identity Eligibility Committee: Upon receipt of such notice the NSAA shall take the following actions:

(1) Gender Identity Eligibility Committee: The NSAA shall convene the Gender Identity Eligibility Committee (Committee) specifically trained to respond to gender identity eligibility inquiries to review the Transgender Student Application. The Committee shall make written findings and determinations approving or disapproving the Transgender Student Application to be set forth in writing and delivered confidentially to the member school and the Executive Director of the NSAA. The eligibility of the student to participate in NSAA activities must be approved unanimously by the Committee considering the Transgender Student Application. This Committee will be comprised of the following persons:

i. Physician with experience in transgender health care.
ii. Psychiatrist, psychologist, or licensed mental health professional.

- iii. School administrator from a non-appealing school.
- iv. NSAA staff member.

(2) Information to be provided to the Committee: The following information shall be provided by the member school to the Committee with regard to the Transgender Student Application:

- i. Current school registration information;
- ii. A written statement from the student and parent(s)/guardian(s) affirming the consistent gender identity and expression to which the student self-relates;
- iii. Documentation from individuals such as, but not limited to, parents, friends and/or teachers, affirming the actions, attitudes, dress and manner and demonstrate the student's consistent gender identification and expression;
- iv. Written verification from an appropriate health-care professional (physician, psychologist) of the student's consistent gender identification and expression;
- v. Medical documentation of hormonal therapy, sexual re-assignment surgery, physiological testing, counseling, and other medical or psychological interventions on behalf of the student.
- vi. Any other relevant documentation or information provided by the member school or the student or the student's parents or guardians.

(3) Review Criteria: The following review criteria should be used by the Committee to review and determine whether to approve or disapprove the Transgender Student Application:-

- i. For the Committee to approve the Transgender Student Application the information presented must establish to the members of the Committee that the transgender student has met each of the following criteria:
 - (a) That the transgender student affirms and exhibits the consistent gender identity and expression to which the student self-relates;
 - (b) That there has been submitted credible documentation from individuals such as, but not limited to, parents, friends and/or teachers, affirming the actions, attitudes, dress and manner and demonstrate the student's consistent gender identification and expression;

(c) That there has been submitted credible written verification from an appropriate health-care professional (physician, psychologist) of the student's consistent gender identification and expression; and,

(d) For a transgender female (or Male-to-Female) (MTF) student only, that there has been submitted credible medical documentation of hormonal therapy, sexual re-assignment surgery and physiological testing; such documentation must establish that the transgender female has either completed a minimum of one year of hormone treatment related to gender transition⁸ or undergone medically confirmed gender reassignment procedure, and, demonstrated to the Committee through a medical examination and testing and physiological testing that the transgender female student athlete does not possess physical (bone structure, muscle mass, and/or testosterone hormonal levels, etc.) or physiological advantages over genetic females of the same age group.

(4) Further Policies:

i. Hormone supplementation/suppression therapy under supervision of a licensed physician when taken as prescribed does not violate the NSAA Performance Enhancing Supplement policy.

ii. In any case where a transgender student athlete is taking hormone treatment related to gender transition, that treatment must be monitored by a physician, and the NSAA must receive regular reports about the athlete's eligibility according to these guidelines.

iii. Once a student is approved as a transgender student athlete in an NSAA sport(s), the student may not return to his/her gender identified on the birth certificate for athletics participation purposes unless another evaluation is undertaken by the NSAA Gender Identity Eligibility Committee because of a change in circumstances. A transgender female (Male-to-Female or MTF) student may participate on a boys' team pursuant to paragraph C.2. above [e.g. when there is no girls sport or comparable sport (e.g., softball and baseball) or team offered in that sport by the member school]. A transgender male (Female-to-Male or FTM) student who has been approved for participation on male teams under this policy shall not be eligible for participation on female teams pursuant to paragraph C.2. above.

iv. If the student is denied participation as a transgender student athlete in an NSAA sport(s), the student's eligibility remains with the school's teams as determined by the individual's birth certificate.

v. Nothing in this policy shall be construed to encourage parents and guardians of students or the students themselves to undergo sex

⁸ See, World Professional Association for Transgender Health, "Standards of Care for the Health of Transsexual, Transgender, and Gender Non-Conforming People", 2012 Edition, pages 36-38.

reassignment surgery, hormone treatment or other medical treatment resulting in change to the student's gender, as such treatments have obvious physical, psychological and social implications.

5. Appeal Process: If the initial Committee review results in a disapproval by the Committee of the Transgender Student Application, the member school on behalf of the student may seek review of the student's Transgender Student Application for eligibility for participation by an Appeals Committee through the following appeals procedure. The member school shall be responsible to pay all costs related to the appeal of the disapproval of the Transgender Student Application, ~~including the costs of the Appeals Committee.~~

i. The student will be scheduled for an appeal hearing before a second NSAA Gender Identity Eligibility Committee (Appeals Committee) specifically trained to hear gender identity appeals. The NSAA shall schedule a hearing as expeditiously as possible, but in no case later than five (5) school business days prior to the first full interscholastic contest that is the subject of the petition, or within a reasonable time thereafter in cases of emergency, including, but not limited to, any unforeseeable late student enrollment.

ii. The Appeals Committee will be comprised of the individuals identified in subparagraph D.2.d.(1), provided, at least two of the individuals chosen must not have been on the Committee that initially considered the student's Transgender Student Application.

iii. The Appeals Committee shall be provided all information provided to the initial Committee along with the determination of the initial Committee, and such additional information that the member school or the student through the member school wishes to provide the Appeals Committee.

iv. The Appeals Committee shall apply the same review criteria as utilized by the initial Committee, and shall make written findings and determinations approving or disapproving the Transgender Student Application to be set forth in writing and delivered confidentially to the member school and the Executive Director of the NSAA. The eligibility of the student to participate must be approved unanimously by the Appeals Committee considering the Transgender Student Application for participation. The student/student's family and the school on whose sports team the student would be participating will be notified of the Appeals Committee's decision in writing within forty-eight (48) hours once that decision has been reached.

v. Upon completion of the appeal to and through the Appeals Committee, the student will have exhausted all administrative remedies available to him/her. No further appeals with or through the NSAA exist at that point. However, due to the nature of these issues, the same student may have her/his case revisited by the

NSAA as the facts and circumstances of the student evolve or change. The NSAA would not anticipate revisiting a case without a sufficient lapse of time such that the circumstances of the case have changed significantly.

E. Use of restrooms and locker rooms at NSAA athletic contests based upon student gender: It is the purpose of this policy to allow all students to participate fairly and equally in high school athletics and activities, while also upholding the basic principles of privacy and personal dignity held by each student.⁹ While accommodations may be necessary to meet the unique needs of individual students, it is the goal that all students will be able to comfortably participate while respecting the privacy rights of others.

The NSAA acknowledges that many member schools' facilities have been outfitted with changing areas and locker rooms, including restrooms and showers, separated by gender. It has been widely recognized that restrooms and locker rooms are places where students have an expectation of privacy.¹⁰ Maintaining separate restroom and shower facilities for each gender is a cost effective way to retain the reasonable expectation of privacy that students have while using the restroom and changing and showering before and after physical activity.¹¹

A transgender student who has been granted permission by the NSAA to participate in activities of the gender with which the student identifies, but has not undergone sex reassignment surgery, shall at NSAA-sponsored contests be permitted to use the restrooms and locker rooms associated with their birth sex or shall be assigned private toilet, locker and shower room facilities appropriate for the student's gender identity, as appropriate and available.

Coaches are encouraged to use spaces outside the locker room for team meetings or other events where important information is shared with the team. When a member school is traveling, school representatives should identify safe spaces to accommodate a transgender student's need for restrooms and locker rooms and privacy.

⁹ *Iowa Civil Rights Commission v. Burlington Area Community YMCA*, (Administrative Decision) Iowa Department of Inspections and Appeals; *Goins v. West Group*, 635 N.W. 2d 717 (Minn. 2001).

¹⁰ See *Koeppel v. Speirs*, 808 N.W. 2d 177, 181 (Iowa 2011), *Stuart v. Metropolitan Government of Nashville*, 679 F. Supp. 2d 851, 859-60.

¹¹ See *State v. Dennison*, 2012 WL 1580610 (Ohio App. 2012).

C. The proposal deals with: Yearbook: Article 2 Section: 2.14.1 Page: 30

2.14.1 In accordance with Federal and State Laws and the interpretation of these laws, the Association, through its membership shall support equal opportunities for all students regardless of race, gender, national origin, or disability. A STUDENT'S GENDER IS DETERMINED BY THE SEX NOTED ON HIS/HER CERTIFICATE AT BIRTH.

Will this proposal impact cost to the School? NO

Will this proposal impact cost to the NSAA? NO

Will this proposal increase travel for the participating schools? NO

Will this proposal impact a student or coach's loss of instruction time? NO

Rationale for the proposed change:

PROS: This legislative proposal would maintain the Association's current practice that supports a student's equal opportunity to participate in NSAA activities based on the sex noted on the student's birth certificate at the time of birth. There are several reasons for maintaining this practice and for stipulating this policy in the Association's bylaws:

- It enables all students in current member schools to continue to participate in NSAA activities, and would help to maintain the membership of the current member schools of the Association;
- It acknowledges that all students have legitimate safety and fairness concerns in participation in NSAA activities, and a right to bodily privacy and to perceived and actual safety in the use of sex-segregated facilities in conjunction with those activities;
- It recognizes the obligation of member schools to provide a protective environment for their students, including safe activities and safe and appropriate facilities to be used in conjunction with those activities;
- It avoids supporting or encouraging psychological or medical interventions, the long-term effects of which are largely unknown, for students with gender dysphoria, while still allowing these students to participate in NSAA activities in accordance with the sex indicated on their birth certificate at the time of birth;
- It would avoid the creation of legal liability for the Association in the future, if the NSAA were to adopt a participation policy for students with gender dysphoria based on current but scientifically unproven psychological or medical treatments for gender dysphoria in adolescents that may later prove to be inappropriate or harmful;
- It respects the First Amendment free exercise rights of religiously-affiliated member schools;
- It respects the conscience rights of individual staff, parents and students at public schools, and would not require them to participate in potentially objectionable "gender sensitization" education and training; and,
- It reflects the policy that has been adopted in other states, including Georgia and North Carolina.

CONS: None

PROPOSED IMPLEMENTATION DATE: 2016-2017

Proposal Passed by Districts IV.

D. The proposal deals with: Yearbook: Article 2 Section: 2.14.1 Page: 30

2.14.1 In accordance with Federal and State Laws and the interpretation of these laws, the Association, through its membership shall support equal opportunities for all students regardless of race, gender, national origin, or disability. A STUDENT'S GENDER IS DETERMINED BY THE SEX NOTED ON HIS/HER CERTIFICATE..

Will this proposal impact cost to the School? NO

Will this proposal impact cost to the NSAA? NO

Will this proposal increase travel for the participating schools? NO

Will this proposal impact a student or coach's loss of instruction time? NO

Rationale for the proposed change:

PROS: This legislative proposal would maintain the Association's current practice that supports a student's equal opportunity to participate in NSAA activities based on the sex noted on the student's

birth certificate at the time of birth. There are several reasons for maintaining this practice and for stipulating this policy in the Association's bylaws:

- It enables all students in current member schools to continue to participate in NSAA activities, and would help to maintain the membership of the current member schools of the Association;
- It acknowledges that all students have legitimate safety and fairness concerns in participation in NSAA activities, and a right to bodily privacy and to perceived and actual safety in the use of sex-segregated facilities in conjunction with those activities;
- It recognizes the obligation of member schools to provide a protective environment for their students, including safe activities and safe and appropriate facilities to be used in conjunction with those activities;
- It avoids supporting or encouraging psychological or medical interventions, the long-term effects of which are largely unknown, for students with gender dysphoria, while still allowing these students to participate in NSAA activities in accordance with the sex indicated on their birth certificate at the time of birth;
- It would avoid the creation of legal liability for the Association in the future, if the NSAA were to adopt a participation policy for students with gender dysphoria based on current but scientifically unproven psychological or medical treatments for gender dysphoria in adolescents that may later prove to be inappropriate or harmful;
- It respects the First Amendment free exercise rights of religiously-affiliated member schools;
- It respects the conscience rights of individual staff, parents and students at public schools, and would not require them to participate in potentially objectionable "gender sensitization" education and training; and,
- It reflects the policy that has been adopted in other states, including Georgia and North Carolina.

CONS: None

PROPOSED IMPLEMENTATION DATE: 2016-2017

Proposal Passed by Districts III.

E. The proposal deals with: Yearbook: Article 3 Section 1.1 Page 1

For the sports of Volleyball and Baseball: A season begins on the first day of allowable practices for that sport, as designated in 3.1.1.2 below. The season officially ends with the conclusion of the State Championship in that sport. Students may not participate in outside group instruction or competition until the school VARSITY team has been completely eliminated from further participation in the sport. STUDENTS WHO ARE NOT LISTED ON THE NSAA DISTRICT ENTRY FORM MAY PARTICIPATE IN OUTSIDE GROUP INSTRUCTION OR COMPETITION OF THE SAME SPORT BEFORE THE COMPETITION. THOSE STUDENTS WHO HAVE PARTICIPATED IN OUTSIDE GROUP INSTRUCTION OR COMPETITION FOLLOWING THEIR REGULAR SEASON SCHEDULED, WOULD NOT BE ELIGIBLE TO BE PLACED ON THE DISTRICT OR STATE ENTRY FORM OF THE SAME SPORT AND WOULD NOT BE ALLOWED TO PRACTICE WITH THE VARSITY TEAM.

Will the proposal impact cost to School? NO

Will this proposal impact cost to the NSAA? NO

Will this proposal increase travel for the participating schools? NO

Will this proposal impact a student or coach's loss of instruction time? NO

Rationale for the proposed change:

Pros: Eliminates the restriction placed on students whose high school season is officially over and are no longer practicing or playing with the varsity team. These students will not be placed on the district/state entry form.

Currently, the bylaw allows students to participate in outside group instruction or competition once the varsity team loses in districts/state. This proposal would give that opportunity to all students who are not members of a varsity team that is still participating in districts/state.

Eliminates the potential of having to penalize a varsity team or a member school for the actions of a student who is not on the varsity team and is no longer under the direct supervision of a high school coach.

Prior to heading off for our holiday break, most of us superintendents will be putting finishing touches on some items from the fall semester that might still need a little attention, and will soon begin the full steam ahead process of making sure the school year finishes smoothly and we are ready to begin again next fall.

While you are gearing up for the run ahead, I would ask that you take time to give thought to a very important topic we will be called upon to decide in the very near future. At our January NSAA district meetings Nebraska schools will be asked to vote on a couple of transgender participation policies. That vote will ultimately decide where Nebraska goes as a state with respect to this topic.

I'm sure most of you are aware of what has transpired to bring us to this pivotal vote, but I will give a quick review. At the fall NSAA meetings two transgender policy proposals were advanced from two separate districts. Simply stated one of those policies said that NSAA participation would be determined by a student's "certificate at birth", the other said that participation would be determined by a student's "birth certificate". While a subtle difference, the wording does matter. With the "certificate at birth" wording all participation would be based on the sex of a child when they are born. "Birth certificate" wording would allow for participation based on what is currently on a student's certificate. Nebraska statute 71-604.01 allows for a birth certificate to be changed if a sex reassignment surgery is performed. These two proposals will be voted upon at the NSAA district meetings to be held between January 6th and January 13th.

At the December 9th meeting of the NSAA Board of Directors another transgender participation policy was considered and advanced for a final reading at their January 14th meeting. The policy being considered by the Board of Directors would allow for the participation of transgender students (view this 7 page proposed policy at <http://nsaahome.org/gender-participation-policy-draft/>). This policy is being considered as an Approved Ruling, which means that it would only be considered by the Board of Directors and would not go through the legislative process that involves a vote of all the NSAA member schools. This policy proposal is a very elaborate document that spells out a review by an NSAA established Gender Identity Eligibility Committee, and may involve statements of gender association from parents, friends, teachers and health-care professionals. The policy also has provisions for Medical documentation of hormonal therapy, sexual re-assignment surgery, and physiological testing. This proposal further states, that for male to female transgender students physiological testing indicates the transgender female student athlete does not possess physical (bone structure, muscle mass, and/or testosterone hormonal levels, etc.) or physiological advantages over genetic females of the same age group.

While I have the utmost respect for the members of the NSAA Board of Directors and for Dr. Tenopir, I feel compelled to encourage schools across the state to move in the direction promoted by the proposals that have come out of the district meetings. Here are some points I would like you to consider as you prepare to direct your school's vote on this important issue:

- The safeguards that the Board of Directors' proposal puts in place are a clear indicator that they have grave concerns about creating situations where female athletes are put at a disadvantage. Despite these provisions there is certainly the chance that one transgender athlete could dramatically impact the equitable landscape for female athletes that schools have worked for years to create. (Bruce Jenner would be a clear example of this. Suppose he had changed his gender as a high school student.) Is there universal agreement on when the bone structure, muscle mass or testosterone hormonal levels are such that no advantage exists? Further, once a tall or a muscular transgender student challenges a denial to participate will those safeguards be thrown out all together?
- I appreciate the concern that the NSAA has about ending up being sued by an individual or an organization if a restrictive policy is put in place. However, I believe that the language in the Board of Directors policy creates as many, if not more, openings for litigation. There are clearly defined expectations for discrimination based on physical characteristics. The language that exists in this proposal with regard to locker room and restroom facilities are also logical openings for attack.

- Basing participation on the sex of an individual as indicated by their birth certificate is a much less discriminatory practice. The NSAA, nor any member school, has had anything to do with defining how that standard is determined. I would encourage the “certificate at birth” terminology as I see it as the least discriminatory. Every student is given an equal opportunity based on the sex they are born with. If you allow a different set of guidelines for a changed certificate then you have now created an unfair advantage for those students who have the financial means to afford surgeries, hormone treatments, and legal wrangling.

- Finally, and maybe most importantly, I think this type of significant, defining legislation for the NSAA should come through the membership. The NSAA is a member driven organization and those members should be driving this decision.

One of the ideals that makes Nebraska a great place to live and raise families is that we are a state that is willing to stand up for the values we feel are important. This is why we have a Unicameral legislature and have not adopted the common core standards. I want every student in Nebraska to have the best possible educational experience, including transgender students. In order to provide the best possible for all I feel it is incumbent upon us to not bow down to political correctness and to stand on the values that makes our state great.

When the January NSAA district meetings come I would encourage your school to vote for the “certificate at birth” proposal. If that direction is too fraught with concern as to make it unlikely to pass in your district then please consider putting your support behind the “birth certificate” proposal. Perhaps the best scenario would be to have both proposals move forward so that the representative assembly can weigh pros and cons and pin down the best proposal.

Thank you for your consideration!

Matt Fisher, Superintendent
Northwest Public Schools
[\(308\) 385 - 6398](tel:3083856398)

Fellow administrators

First, I would like to say Thank You to Matt Fisher for sharing his thoughts about the Transgender topic with everyone, and in helping open the dialogue on a very touchy topic. Second, I want to inform the constituency that Ogallala Public Schools will be supporting the proposal submitted during the November District meetings. I agree with Matt when he stated, “basing participation on the sex of an individual as indicated by their birth certificate is a much less discriminatory practice.” I also agree that every student is given an equal opportunity based on the sex they are born with. If you allow a different set of guidelines for a changed certificate then you have now created an unfair advantage for those students who have the financial means to afford surgeries, hormone treatments, and legal wrangling.

Carl Dietz

My name is John Noble. I am a former resident of Nebraska and a committed Catholic. I am writing you today in order to encourage you to **oppose** the “sex at birth” bylaw proposal being proposed for the NSAA, which disrespects the dignity of transgender Nebraskan students, and disallows their full participation in important activities across the state.

I am a Catholic. I believe in the life and dignity of all persons, including our transgender siblings. This proposal disrespects these fundamental tenets of Catholicism by denying transgender students' life and dignity. Why should transgender students be turned away from full participation in school activities? This proposal is based on fear-mongering that has no basis in reality.

I am also a Nebraskan by birth, and a former participant in NSAA activities (speech team and tennis). These activities changed who I am as a person, they shaped who I am and how I see the world. I cannot bear the thought of someone being turned away from these activities because they felt unsafe. The sex at birth bylaw proposal would create an unsafe environment for transgender students, and would not allow them to participate in the activities that changed my life.

Please **oppose** the sex-at-birth bylaw proposal and **support** the Gender Participation Policy. The safety, life, and dignity of transgender Nebraskans depend upon it.

Sincerely,
John Noble



NEBRASKA SCHOOL ACTIVITIES ASSOCIATION

Gender Participation Policy



PURPOSE OF POLICY

- Provide participation opportunities for ALL students, to the extent possible
- Key purposes: safety, competitive equity, preservation of privacy
- Reportedly there are transgender students in Nebraska high schools wishing to participate
- NSAA bylaws do not address participation by transgender students
- It's deemed preferable for NSAA to have protocol, rather than have the courts make every participation decision
- Need policy to assist schools who are dealing with transgender issues

NSAA Gender Participation Board Policy



INPUT FROM MANY...

- Executive Director has taken time to interact with many groups and individuals: administrators, school board members, NDE, state senators, church groups, ACLU & physicians—many with closely held beliefs on all sides
- General observations: schools dealing with transgender issue and seeking leadership; issue will not go away; competitive equity and fairness are concerns; restroom and dressing facilities are hot button topics

NSAA Gender Participation Board Policy

WHAT SHOULD POLICY BE?



- Types of "transgender participation" policies across the country:
 - how a student identifies; birth certificate policy; hormonal treatments; sex reassignment surgery/procedures
- Two policy considerations in January District meetings
 - Sex stated on certificate "at birth"
 - Sex stated on birth certificate subject to Application for Participation by member school on behalf of transgender student
- To our knowledge, no state has strict "birth certificate" policy without options for modifications

NSAA Gender Participation Board Policy

WHAT NEBRASKA LAW OR REGULATION MAY APPLY TO AN NSAA POLICY?



- Neb. Rev. Stat. § 71-604.01 (2005). "Upon receipt of a notarized affidavit from the physician that performed sex reassignment surgery on an individual born in this state and a certified copy of an order of a court of competent jurisdiction changing the name of such person, the Department of Health and Human Services Finance and Support shall prepare a new certificate of birth in the new name and sex of such person in substantially the same form as that used for other live births. The evidence from which the new certificate is prepared and the original certificate of birth shall be available for inspection only upon the order of a court of competent jurisdiction."

On Board Policy

WHAT IS THE PROCESS?



- Under the NSAA Constitution the Board has the authority to establish policy in the form of an Approved Ruling
- Board is considering policy (Approved Ruling) addressing "gender participation" which includes participation by a transgender student
- Gender Participation Policy presented to Board on First Reading on December 9, 2015
- Final reading and action by the Board scheduled for January 14, 2016
- Board action scheduled AFTER January district meetings.

NSAA Gender Participation Board Policy

CONTENTS OF GENDER PARTICIPATION POLICY



- Participation initially determined by sex on birth certificate
- Girls may participate on boys teams when there is no girls' sport or comparable sport
- Boys are not allowed to play girls sports or on girls teams even when there is no corresponding boys sport
- Procedures for transgender participation begins with student/parent requesting in writing ability for student to participate as transgender athlete

NSAA Gender Participation Board Policy

SEQUENCE OF POLICY STEPS



- School initially makes decision whether they are in agreement with such student participating and assures NSAA eligibility
- School petitions NSAA for participation considerations if school deems they are OK with student participating
- NSAA "Gender Identity Eligibility Committee" would be convened
- Gender Identity Eligibility Committee comprised of physician, psychologist/psychiatrist, NSAA staff, school administrator not from application school

NSAA Gender Participation Board Policy

INFO PROVIDED TO COMMITTEE



- Current school registration information
- Written statement from student/parents affirming consistent gender identity/expression
- Documentation from others to affirm actions, attitudes, dress demonstrating consistent gender identity
- Written verification from appropriate healthcare professional of the student's consistent gender identity

NSAA Gender Participation Board Policy

INFO PROVIDED TO COMMITTEE



- Medical documentation of hormonal therapy, sex reassignment surgery, counseling, and other medical or psychological interventions
- Other relevant information or documentation from member school, student or parents

NSAA Gender Participation Board Policy

COMMITTEE - APPROVAL/DISAPPROVAL

For the Committee to approve the Transgender Student Application, the information presented must establish to the members of the Committee that the transgender student has met each of the following criteria:



- (a) That the transgender student affirms and exhibits the consistent gender identity and expression to which the student self-relates;

NSAA Gender Participation Board Policy

COMMITTEE - APPROVAL/DISAPPROVAL



- (b) That there has been submitted credible documentation from individuals such as, but not limited to, parents, friends and/or teachers, affirming the actions, attitudes, dress and manner and demonstrate the student's consistent gender identification and expression;

NSAA Gender Participation Board Policy

COMMITTEE - APPROVAL/DISAPPROVAL



(c) That there has been submitted creditable written verification from an appropriate health-care professional (physician, psychologist) of the student's consistent gender identification and expression; and,

NSAA Gender Participation Board Policy

COMMITTEE - APPROVAL/DISAPPROVAL



(d) For a transgender female (or Male-to-Female or MTF) student only, that there has been submitted creditable medical documentation of hormonal therapy, sexual re-assignment surgery and physiological testing; . . .

NSAA Gender Participation Board Policy

COMMITTEE - APPROVAL/DISAPPROVAL



... continued (d) such documentation must establish that:

- the transgender female (MTF) has either completed a minimum of one year of hormone treatment related to gender transition or undergone medically confirmed gender reassignment procedure, and,
- demonstrated to the Committee through a medical examination and testing and physiological testing that the transgender female student athlete does not possess physical (bone structure, muscle mass, and/or testosterone hormonal levels, etc.) or physiological advantages over genetic females of the same age group.

NSAA Gender Participation Board Policy

FURTHER POLICIES



- Hormone therapy under supervision of licensed physician doesn't violate Performance Enhancing Supplement policy
- Hormone treatment **MUST** be under supervision of physician
- NOTHING** in policy to be construed as encouragement to undergo any gender modification procedures—obvious physical, psychological and social implications

NSAA Gender Participation Board Policy

FURTHER POLICIES



- Once approved as transgender athlete, student may not revert to original gender without another evaluation.
- A MTF student may participate on a boys' team pursuant to paragraph C.2. of the Policy [e.g. when there is no girls sport or comparable sport (e.g., softball and baseball) or team offered in that sport by the member school].
- A FTM student who has been approved for participation on male teams under this policy shall not be eligible for participation on female teams pursuant to paragraph C.2. of the Policy.

NSAA Gender Participation Board Policy

FURTHER POLICIES



- Student denied participation as transgender athlete has eligibility as determined by birth certificate
- Schools may access appeal process for denied transgender student
- Appeal Committee same make-up as original committee with at least two of the committee members being new
- Appeal exhausts NSAA administrative remedies

NSAA Gender Participation Board Policy

RESTROOMS/LOCKER ROOMS



- Policy to allow fair and equal participation, still maintaining privacy—for athlete and others
- Students have general expectation of privacy in restrooms and locker rooms
- A transgender student granted permission to participate and not had sex reassignment surgery shall at NSAA-sponsored events be permitted birth-sex restrooms and locker rooms, or assigned private facilities

District V Leadership:

As all of you are aware, next week is the January District V Managing Committee meeting in Holdrege, NE (The Tassel) at 1:00 p.m. (C.S.T.)/12:00 p.m. (M.S.T.). With that being less than a week away, I have heard from some of you in regards to the Transgender issue so I am sending this e-mail out that will hopefully give you some information to work with.

The two by-law proposals ("C" and "D" in your packet) will be presented for the membership to vote on. Item "C" is "Birth Certificate at Birth" and Item "D" is "Birth Certificate". The "C" proposal has no option for a change thus providing no opportunity for a transgender student to participate other than what their gender is listed as at birth. Proposal "D" would allow participation for a person that has had the birth certificate amended according to the Nebraska State Statute that provides for such following a sex reassignment surgery.

In addition to the two proposals that will be voted on, there is a Gender Participation Policy (Approved Ruling) that the Board of Directors passed on first reading on 12/09/2015. The second reading of this policy is scheduled for the January Board meeting on 01/14/2016. A copy of that policy was sent to the District V membership following the December meeting. Hopefully you have had an opportunity to read that policy in its entirety. Dr. Tenopir and NSAA legal counsel prepared and sent out a webinar explaining the Gender Participation Policy on Friday, 12/18/2015. Again, I hope that you have taken the time to watch the webinar in its entirety. At the end of this e-mail, I am attaching a powerpoint presentation as well as the corresponding handout's that were prepared to present the Gender Participation Policy at the December board meeting.

In looking ahead, should the Gender Participation Policy (Approved Ruling) be passed on second reading by the Board of Directors at the January Board meeting, it would go into effect immediately. If one, or both, of the by-law proposals pass through district membership voting and Representative Assembly, that proposal would supersede the Approved Ruling passed by the Board. However, a proposal that is

passed by Representative Assembly will not take effect until August of the next school year (August 2016).

This is a lot of information but I certainly want you to be a well-informed as possible. I am looking forward to seeing all of you in Holdrege next week. If you have questions, please let me know.

Alan Garey
NSAA Board of Directors District V

NEBRASKA DEPARTMENT OF EDUCATION
SCHOOL FINANCE & ORGANIZATION SERVICES

2016/17 CURRENT STATUTE MODEL OF STATE AID CALCULATED BY SYSTEM ON JANUARY 8, 2016

LER : 1.00

SYSTEM COUNTY/DISTRICT NUMBER	SYSTEM NAME	FORMULA NEEDS	YIELD FROM LOCAL EFFORT RATE	NET OPTION FUNDING	INCOME TAX REBATE	OTHER RECEIPTS	MINIMUM LEVY ADJUSTMENT	TOTAL RESOURCES	EQUALIZATION AID	NON-EQUAL MINIMUM LEVY ADJUSTMENT	TOTAL STATE AID CALCULATED
DODGE											
27-0594-000	LOGAN VIEW PUBLIC SCHOOLS	6,786,233	8,145,237	378,314	52,365	889,164	1,936,937	11,402,017	0	(52,365)	378,314
27-0595-000	NORTH BEND CENTRAL PUBLIC SCHS	7,307,392	10,113,640	858,126	56,503	921,574	4,129,399	16,079,242	0	(56,503)	858,126
DUNDY											
29-0117-000	DUNDY CO STRATTON PUBLIC SCHS	5,429,847	10,114,588	0	50,930	599,038	4,404,903	15,169,459	0	(50,930)	0
FILLMORE											
30-0001-000	EXETER-MILLIGAN PUBLIC SCHOOLS	3,007,633	6,851,078	0	42,746	418,889	2,528,733	9,841,446	0	(42,746)	0
30-0025-000	FILLMORE CENTRAL PUBLIC SCHS	6,786,666	10,998,062	0	84,276	1,641,761	4,124,273	16,848,372	0	(84,276)	0
30-0054-000	SHICKLEY PUBLIC SCHOOLS	2,431,519	5,074,141	36,909	25,415	348,395	2,256,978	7,741,838	0	(25,415)	36,909
FRANKLIN											
31-0506-000	FRANKLIN PUBLIC SCHOOLS	4,186,552	4,740,705	202,998	31,033	521,831	0	5,496,567	0	0	234,031
FRONTIER											
32-0046-000	MAYWOOD PUBLIC SCHOOLS	2,790,426	3,430,353	156,862	10,893	184,636	447,661	4,230,405	0	(10,893)	156,862
32-0095-000	EUSTIS-FARNAM PUBLIC SCHOOLS	3,137,479	4,314,596	230,679	24,473	357,981	1,556,275	6,484,004	0	(24,473)	230,679
32-0125-000	MEDICINE VALLEY PUBLIC SCHOOLS	3,340,591	2,813,047	110,726	17,353	348,397	0	3,289,523	51,068	0	179,147
FURNAS											
33-0018-000	ARAPAOE PUBLIC SCHOOLS	4,642,853	4,912,560	0	31,539	585,873	980,056	6,510,028	0	(31,539)	0
33-0021-000	CAMBRIDGE PUBLIC SCHOOLS	4,725,632	3,376,291	378,314	27,379	621,980	337,291	4,741,255	0	(27,379)	378,314
33-0540-000	SOUTHERN VALLEY SCHOOLS	6,018,146	8,153,170	0	36,975	768,630	1,263,741	10,222,516	0	(36,975)	0
GAGE											
34-0001-000	SOUTHERN SCHOOL DIST 1	5,522,656	3,830,671	0	28,408	826,300	0	4,685,379	837,277	0	865,685
34-0015-000	BEATRICE PUBLIC SCHOOLS	20,110,512	11,247,789	0	232,236	3,237,325	0	14,717,350	5,393,162	0	5,625,398
34-0034-000	FREEMAN PUBLIC SCHOOLS	5,422,302	4,923,727	516,721	43,136	594,247	614,481	6,692,312	0	(43,136)	516,721
34-0100-000	DILLER-ODELL PUBLIC SCHOOLS	3,696,623	6,476,416	0	27,963	482,052	2,456,505	9,442,936	0	(27,963)	0
GARDEN											
35-0001-000	GARDEN COUNTY SCHOOLS	3,933,799	6,701,819	0	28,689	656,833	3,572,740	10,960,081	0	(28,689)	0
GARFIELD											
36-0100-000	BURWELL PUBLIC SCHOOLS	4,486,826	4,057,189	332,178	29,641	374,159	527,029	5,320,196	0	(29,641)	332,178
GOSPER											
37-0030-000	ELWOOD PUBLIC SCHOOLS	3,424,316	4,532,966	0	34,560	479,490	1,111,936	6,158,972	0	(34,560)	0
GRANT											
38-0011-000	HYANNIS AREA SCHOOLS	2,531,829	4,707,900	64,590	32,831	331,135	2,324,290	7,460,746	0	(32,831)	64,590
GREELEY											
39-0060-000	CENTRAL VALLEY PUBLIC SCHOOLS	5,082,184	7,831,660	0	29,150	600,086	2,897,714	11,358,610	0	(29,150)	0

**2016/2017 PROJECTED BUDGET AUTHORITY AND ALLOWABLE RESERVE PERCENTAGE
 BASED ON CURRENT STATUTE**

DRAFT

COUNTY/ DISTRICT NUMBER	DISTRICT NAME	CLASS	2016/17 BUDGET AUTHORITY	METHOD	RESERVE %
28-0059-000	BENNINGTON PUBLIC SCHOOLS	3	20,025,849	SGA	35
28-0066-000	WESTSIDE COMMUNITY SCHOOLS	3	56,185,283	B	25
29-0117-000	DUNDY CO STRATTON PUBLIC SCHS	3	6,459,859	B	45
30-0001-000	EXETER-MILLIGAN PUBLIC SCHOOLS	3	4,305,174	B	45
30-0025-000	FILLMORE CENTRAL PUBLIC SCHS	3	6,414,898	B	35
30-0054-000	SHICKLEY PUBLIC SCHOOLS	3	2,531,994	B	45
31-0506-000	FRANKLIN PUBLIC SCHOOLS	3	4,875,931	B	45
32-0046-000	MAYWOOD PUBLIC SCHOOLS	3	2,950,073	F	45
32-0095-000	EUSTIS-FARNAM PUBLIC SCHOOLS	3	4,371,646	B	45
32-0125-000	MEDICINE VALLEY PUBLIC SCHOOLS	3	3,361,843	B	45
33-0018-000	ARAPAHOE PUBLIC SCHOOLS	3	4,482,526	B	45
33-0021-000	CAMBRIDGE PUBLIC SCHOOLS	3	4,871,846	B	45
33-0540-000	SOUTHERN VALLEY SCHOOLS	3	6,316,648	B	45
34-0001-000	SOUTHERN SCHOOL DIST 1	3	5,349,482	B	45
34-0015-000	BEATRICE PUBLIC SCHOOLS	3	25,355,425	B	35
34-0034-000	FREEMAN PUBLIC SCHOOLS	3	5,342,870	F	45
34-0100-000	DILLER-ODELL PUBLIC SCHOOLS	3	3,978,657	B	45
35-0001-000	GARDEN COUNTY SCHOOLS	3	5,314,277	B	45
36-0100-000	BURWELL PUBLIC SCHOOLS	3	5,127,072	B	45
37-0030-000	ELWOOD PUBLIC SCHOOLS	3	3,395,880	B	45
38-0011-000	HYANNIS AREA SCHOOLS	3	2,714,519	B	45
39-0060-000	CENTRAL VALLEY PUBLIC SCHOOLS	3	5,864,039	B	45
40-0002-000	GRAND ISLAND PUBLIC SCHOOLS	3	90,539,783	F	25
40-0082-000	NORTHWEST PUBLIC SCHOOLS	3	15,288,900	B	35
40-0083-000	WOOD RIVER RURAL SCHOOLS	3	7,048,159	B	35
40-0126-000	DONIPHAN-TRUMBULL PUBLIC SCHS	3	5,844,111	F	35
41-0002-000	GILTNER PUBLIC SCHOOLS	2	2,870,373	F	45
41-0091-000	HAMPTON PUBLIC SCHOOLS	3	2,609,038	B	45

2015-16 Budget Authority \$4,768,656

2016-17 Projected Budget Authority is \$4,875,931 Based on current statute = **\$107,275 more**

2015-17 State Aid is \$45,958.55

2016-17 Projected State Aid is \$234,031 Based on current statute = **\$188,072.45 more**

Superintendent's Report
January 11, 2016

Candy's Contact Information

E-mail: candace.conradt@fpsflyers.org

Cell Phone: 402-340-6103

Mtgs. & Activities Attended

Tuesday, December 29	Holiday Basketball Tournament - Superior
Monday, January 4	Professional Development – Teachers Community/School Partnership for Essential Planning Meeting
Thursday, January 7	Basketball vs Alma
Saturday, January 9	Franklin Wrestling Tournament

Community/School Partnership for Essential Planning Meeting

I was very pleased with the meeting Monday evening and look forward to the remaining meetings.

Legislative Session

The Nebraska Legislature convened this past week. The sixty-day ("short") session is scheduled to adjourn on April 20th.

Bill introduction began and will continue for 10 session days (until January 20th). The typical number of bills introduced in a short session is between 400 to 500 new pieces of legislation. One of the first items of business was the election of Sen. Kolterman, as new Chair of the Legislature's Retirement Committee. The previous Chair, Senator Jeremy Nordquist, resigned his seat in the Legislature last year.

I will be attending the Legislative Conference on Sunday, January 31 & Monday, Feb 1.

I will keep you informed as the session progresses.

Comments on My First Semester Evaluation

I was very pleased with my evaluation. The first 6 months have flown by and I believe that the faculty and staff have developed a great working relationship. We have excellent people in our school.