

CITY OF CRETE, NEBRASKA  
CITY COUNCIL REGULAR MEETING  
February 5, 2013

Notice of the meeting was given by posting and publishing in The Crete News, the appointed method for giving notice as shown by the Proof of Publication attached to the minutes. Advance notice of the meeting was also given to the Mayor and City Council. Pursuant to Section 84-1412(8) of the Nebraska Open Meetings Act, the City has posted a current copy of the Open Meetings Act, Laws of the State of Nebraska in the back of the Council Chambers. Additional copies are available to read. The City may consider items listed on the agenda in random order. All proceedings shown were taken while the meeting was open to the attendance of the public.

Those in attendance pledged allegiance to the flag.

1. Open Meeting
2. Roll Call
3. Petitions - Communications - Citizen Concern
4. Special Order of Business
- 4.A. Public Hearing - Special Exception - 6:05 PM

Open public hearing Carried with a motion by Tom Busboom and a second by Jack Oelschlager.  
Tom Busboom: Aye, Kyle Frans: Aye, Jack Oelschlager: Aye, Travis Sears: Aye, Dale Strehle: Aye  
Aye: 5, No: 0

Close hearing at 6:25 PM Carried with a motion by Tom Busboom and a second by Dale Strehle.  
Tom Busboom: Aye, Kyle Frans: Aye, Jack Oelschlager: Aye, Travis Sears: Aye, Dale Strehle: Aye  
Aye: 5, No: 0

Approve special exception Withdrawn with a motion by Tom Busboom and a second by Tom Busboom.  
Refer special use exception to Public Works and Public Safety Committees to explore possible issues  
Carried with a motion by Dale Strehle and a second by Tom Busboom.  
Tom Busboom: Aye, Kyle Frans: Aye, Jack Oelschlager: Aye, Travis Sears: Aye, Dale Strehle: Aye  
Aye: 5, No: 0

City Attorney - description of commercial 3 zoning, broadest in City zoning, includes C1 and C2 exceptions. description of special exception considerations. jose diaz 208 juniper - current location too small - opportunity for larger building - make an offer and ask for exception - will purchase property - 80 adults and 50 children - attorney - allowing use will not change zoning - allowing use does not allow making any other changes - churches are primary use in all residential areas and a2 John Mardock - 5411 s 88th lincoln - in favor of allowing, property has been for sale for quite some time - egress and parking are more than adequate - adequate area to add commercial properties to west 6 years in Crete - congregation is growing - laura bell - broker - in favor - ashland - 25 years commercial sales - increase traffic will help bring business to the area Jack - will sidewalks be required - attorney, would be condition of ordinance if desired Jack - is the building sprinkled

- 4.B. Heartland Natural Gas Contract

Approve purchase of natural gas commodity from Heartland Carried with a motion by Tom Busboom and a second by Dale Strehle.  
Tom Busboom: Aye, Kyle Frans: Aye, Jack Oelschlager: Aye, Travis Sears: Aye, Dale Strehle: Aye  
Aye: 5, No: 0

- 4.C. Electric Rate Review Agreement

Approve electric retail rate review by JK Energy Consulting Carried with a motion by Tom Busboom and a second by Jack Oelschlager.  
Tom Busboom: Aye, Kyle Frans: Aye, Jack Oelschlager: Aye, Travis Sears: Aye, Dale Strehle: Aye

Aye: 5, No: 0

4.D. Economic Development Financial Assistance Requests

4.D.1. Carl's Boot Repair

Approve recommendation Carried with a motion by Dale Strehle and a second by Travis Sears.

Tom Busboom: Aye, Kyle Frans: Aye, Jack Oelschlager: Aye, Travis Sears: Aye, Dale Strehle: Aye

Aye: 5, No: 0

4.D.2. City of Crete Baseball Field

Approve recommendation Carried with a motion by Dale Strehle and a second by Travis Sears.

Tom Busboom: Aye, Kyle Frans: Aye, Jack Oelschlager: Aye, Travis Sears: Aye, Dale Strehle: Aye

Aye: 5, No: 0

4.D.3. Isis Theater

Approve recommendation Carried with a motion by Kyle Frans and a second by Dale Strehle.

Tom Busboom: Aye, Kyle Frans: Aye, Jack Oelschlager: Aye, Travis Sears: Aye, Dale Strehle: Aye

Aye: 5, No: 0

Approve recommendation Carried with a motion by Dale Strehle and a second by Travis Sears.

Tom Busboom: Aye, Kyle Frans: Aye, Jack Oelschlager: Aye, Travis Sears: Aye, Dale Strehle: Aye

Aye: 5, No: 0

4.D.4. Tutti Frutti

Approve recommendation Carried with a motion by Kyle Frans and a second by Jack Oelschlager.

Tom Busboom: Aye, Kyle Frans: Aye, Jack Oelschlager: Aye, Travis Sears: Aye, Dale Strehle: Aye

Aye: 5, No: 0

4.D.5. Winterlude

Approve recommendation Carried with a motion by Dale Strehle and a second by Travis Sears.

Tom Busboom: Aye, Kyle Frans: Aye, Jack Oelschlager: Aye, Travis Sears: Aye, Dale Strehle: Aye

Aye: 5, No: 0

4.E. Economic Development Program Director Job Description

4.F. Economic Development Plan Amendment

Set a public hearing for March 5th to consider plan recommendations Carried with a motion by Travis Sears and a second by Jack Oelschlager.

Tom Busboom: Aye, Kyle Frans: Aye, Jack Oelschlager: Aye, Travis Sears: Aye, Dale Strehle: Aye

Aye: 5, No: 0

Set a public hearing for March 5, 2013 at 6:05 PM for the recommended changes to the Economic Development Plan Carried with a motion by Travis Sears and a second by Tom Busboom.

Tom Busboom: Aye, Kyle Frans: Aye, Jack Oelschlager: Aye, Travis Sears: Aye, Dale Strehle: Aye

Aye: 5, No: 0

4.G. Trailer/Spotlight on Right-of-Way February 16

Approve request Carried with a motion by Tom Busboom and a second by Jack Oelschlager.

Tom Busboom: Aye, Kyle Frans: Aye, Jack Oelschlager: Aye, Travis Sears: Aye, Dale Strehle: Aye

Aye: 5, No: 0

4.H. 119 West 13th Street Nuisance Abatement

refer to public works committee with owner Carried with a motion by Jack Oelschlager and a second by Kyle Frans.

Tom Busboom: Aye, Kyle Frans: Aye, Jack Oelschlager: Aye, Travis Sears: Aye, Dale Strehle: Aye

Aye: 5, No: 0

5. Resolutions & Ordinances

5.A. Ordinance 1848 - Water Rates

Introduce and move waive of rules Carried with a motion by Tom Busboom and a second by Dale Strehle.

Tom Busboom: Aye, Kyle Frans: Aye, Jack Oelschlager: Aye, Travis Sears: Aye, Dale Strehle: Aye  
Aye: 5, No: 0

Final approval Carried with a motion by Tom Busboom and a second by Dale Strehle.

Tom Busboom: Aye, Kyle Frans: Aye, Jack Oelschlager: Aye, Travis Sears: Aye, Dale Strehle: Aye  
Aye: 5, No: 0

5.B. Resolution 2013-07 - MEAN Representatives

Introduce and approve Carried with a motion by Dale Strehle and a second by Tom Busboom.

Tom Busboom: Aye, Kyle Frans: Aye, Jack Oelschlager: Aye, Travis Sears: Aye, Dale Strehle: Aye  
Aye: 5, No: 0

5.C. Resolution 2013-08 - Surplus Equipment

Introduce and approve Carried with a motion by Tom Busboom and a second by Jack Oelschlager.

Tom Busboom: Aye, Kyle Frans: Aye, Jack Oelschlager: Aye, Travis Sears: Aye, Dale Strehle: Aye  
Aye: 5, No: 0

6. Officers' Reports

Steve - run hide fight across the city and schools Tom - meeting with usda and engineer about cost estimates for plant also meeting with cold storage about compliace 13th Street project starts early on trees generation rice compliace done by march 30 sendd - downpayment assistance for homes JEO - certified community for development DED visited Crete purina and novel 800,000 Deb - thank you Jacque - thank you for support Jerry - audit firms Mayor - testifying at legislature airport authority - first round biennial budget - first round flood control study - will go to NRDs personnel issue for closed session

7. Consent Agenda

Approve Carried with a motion by Tom Busboom and a second by Travis Sears.

Tom Busboom: Aye, Kyle Frans: Aye, Jack Oelschlager: Aye, Travis Sears: Aye, Dale Strehle: Aye  
Aye: 5, No: 0

7.A. City Council Meeting Minutes

7.A.1. January 15, 2013

7.B. City Council Committee Meeting Minutes

7.B.1. January 15, 2013 Public Works

7.B.2. January 24, 2013 Public Works

7.B.3. January 28, 2013 Public Works

7.C. City Treasurer's Report

7.D. Claims Against the City

8. Adjournment

closed session at 7:00 PM Carried with a motion by Tom Busboom and a second by Dale Strehle.

Tom Busboom: Aye, Kyle Frans: Aye, Jack Oelschlager: Aye, Travis Sears: Aye, Dale Strehle: Aye  
Aye: 5, No: 0

Exit closed session 7:25 Carried with a motion by Tom Busboom and a second by Dale Strehle.

Tom Busboom: Aye, Kyle Frans: Aye, Jack Oelschlager: Aye, Travis Sears: Aye, Dale Strehle: Aye  
Aye: 5, No: 0

Mayor

(SEAL)

City Clerk-Treasurer

I, Jerry Wilcox, City Clerk for the City of Crete, hereby certify that the foregoing is a true and correct copy of the proceedings had and done by the Mayor and Council. I hereby certify that a copy of the Open Meetings Act was posted in the back of the Council Chambers. I certify that all of the subjects included in the foregoing proceedings were contained in the agenda for the meeting, kept continually current and available for public inspection at the office of the City Clerk. I certify that such subjects were contained in said agenda for at least twenty-four hours prior to said meeting and that at least one copy of all reproducible material discussed at the meeting was available at the meeting for examination and copying by members of the public. I certify that the minutes were in written form and available for public inspection within ten working days and prior to the next convened meeting of the City Council. I certify that all news media requesting notification concerning meetings of the City Council were provided with advance notification of the time and place of said meeting and the subjects to be discussed.

---

City Clerk-Treasurer

(S E A L)

January 16, 2013

City of Crete, Nebraska  
City Council Members  
243 E. 13th Street  
PO Box 86  
Crete, NE 68333

Dear Members:

We would like to purchase the building and part of the land located at 2151 Cardinal Lane, Crete, NE 68333 (formerly a car dealership).

We do not currently own this Property and would like to purchase it to be used for our church, Ministerios Pentecostes Maranatha, currently located at 705 West 12th Street, Crete, NE 68333.

This letter is in conjunction with the Application for Special Exception Permit attached.

Sincerely,

  
Guilfo F. Penate, Pastor

  
Asiria Penate, Pastor

Enclosure



243 East 13th Street  
P.O. Box 63  
Crete, NE 68333-0063  
Telephone (402) 618-4312

### CITY OF CRETE APPLICATION FOR SPECIAL EXCEPTION PERMIT

DATE OF APPLICATION: 1/16/13 APPLICATION #: SE 13-1  
ADDRESS OR LOCATION: 2151 Cardinal Lane, Crete, NE 68333

UNDER THE PROVISIONS OF SECTION 11-230 OF THE CITY OF CRETE ZONING REGULATIONS  
THE UNDERSIGNED HEREBY APPLIES FOR A SPECIAL EXCEPTION PERMIT TO:  
Have a church

ON THE PROPERTY DESCRIBED AS LOT(S) A portion of the Property described  
as Crete City (10.5517 AC) Crete Ind. Park Subd. Lots 1-4, Pt 5 & Crete Ind.  
Block Park First Lots 9-10 ADDITION Crete, Saline County, NE (as described in  
the Crete Industrial Park subdivision plat of 1999)  
PROPOSED DEVELOPMENT OF THE PROPERTY IS SHOWN AND PLANS ATTACHED HERETO.  
TYPE AND PROPOSED USE IS AS FOLLOWS:  
For a church service and church offices

APPLICANT NAME: Guilio F. Penate and Asiria Penate  
ADDRESS: Pastors of Ministerios Pentecostes Maranatha  
1855 Arthur Drive, Crete, NE 68333

TELEPHONE #: (402) 314-5172 SIGNATURE: Guilio Penate Asiria Penate

**FOR OFFICIAL USE ONLY BELOW THIS LINE**

DATE PUBLISHED & POSTED:	<u>January 23, 2013</u>	
DATE OF CITY COUNCIL HEARING:	<u>February 5, 2013</u>	
CONDITIONS:	_____	
APPROVED:	_____	DENIED: _____
COPY TO:	BUILDING INSPECTOR: <input checked="" type="checkbox"/>	DATE _____
	CITY CLERK: <input checked="" type="checkbox"/>	DATE _____

# CARDINAL LANE COMMERCIAL SUBDIVISION

## FINAL PLAT

A REPLATTING OF LOT 5 AND ALL OF LOTS 6-9 CRETE INDUSTRIAL PARK SUBDIVISION  
& PART OF LOT 9 AND ALL OF LOT 10 CRETE INDUSTRIAL PARK SUBDIVISION  
CITY OF CRETE, SALINE COUNTY, NEBRASKA

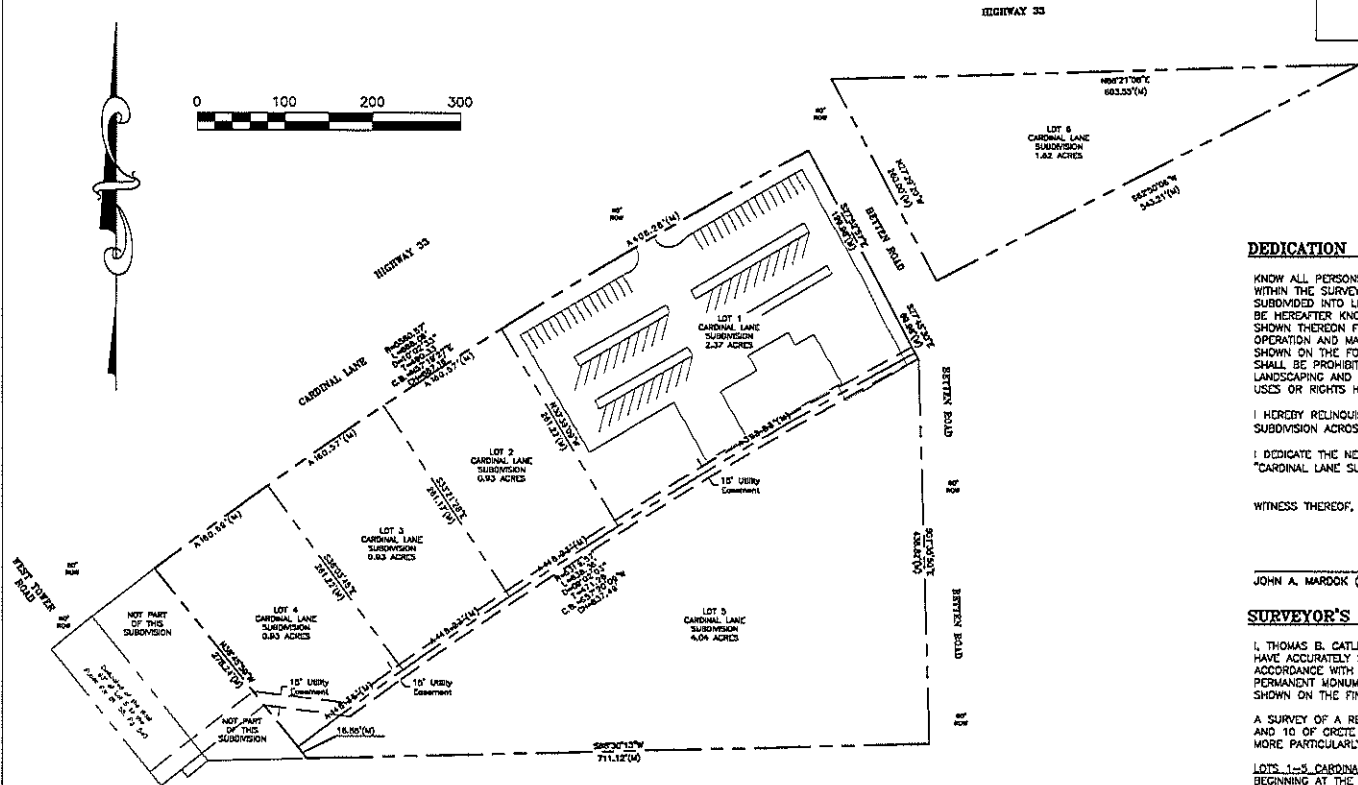

- LEGEND**
- - SET SURVEY POINT AS INDICATED
  - - FOUND SURVEY POINT AS INDICATED
  - △ - CALCULATED SURVEY POINT
  - CTP - CRIMPED TOP PIPE
  - OTP - OPEN TOP PIPE
  - L - MEASURED DISTANCE
  - C - CALCULATED DISTANCE
  - P - PLAT DISTANCE
  - R - RECORDED DISTANCE
  - BOUNDARY LINE

**DEDICATION**

KNOW ALL PERSONS BY THESE PRESENTS, THAT I, JOHN A. MARDOK, OWNER OF THE LAND DESCRIBED WITHIN THE SURVEYORS CERTIFICATE AND ENGRAVED WITHIN THIS PLAT HAVE CAUSED SAID LAND TO BE SUBDIVIDED INTO LOTS AND STREETS, TO BE NUMBERED AND NAMED AS SHOWN, SAID SUBDIVISIONS TO BE HEREAFTER KNOWN AS CARDINAL LANE SUBDIVISION, AND I DO HEREBY DEDICATE THE EASEMENT SHOWN THEREON FOR THE LOCATION, CONSTRUCTION, RECONSTRUCTION, REPLACEMENT, REPAIR, OPERATION AND MAINTENANCE OF PUBLIC SERVICE UTILITIES, OVER UPON OR UNDER THE EASEMENT AS SHOWN ON THE FOREGOING PLAT, THE CONSTRUCTION OR LOCATION OF ANY BUILDINGS OR TREES SHALL BE PROHIBITED IN SAID EASEMENTS, BUT THE SAME MAY BE USED FOR GARDENS, SHRUBS, LANDSCAPING AND OTHER PURPOSES THAT DO NOT THEN OR LATER INTERFERE WITH THE AFORESAID USES OR RIGHTS HEREIN GRANTED.

I HEREBY RELINQUISH THE EXISTING 20' UTILITY EASEMENT PER THE PLAT OF CRETE INDUSTRIAL PARK SUBDIVISION ACROSS THE NEW SUBDIVISION KNOWN AS "CARDINAL LANE SUBDIVISION".

I DEDICATE THE NEW 15' UTILITY EASEMENT AS SHOWN ACROSS THE NEW SUBDIVISION KNOWN AS "CARDINAL LANE SUBDIVISION"

WITNESS THEREOF, I/WE DO HEREBY SET OUR HAND(S) THIS \_\_\_\_\_ DAY OF \_\_\_\_\_, 2013.

JOHN A. MARDOK (OWNER)

**SURVEYOR'S CERTIFICATE**

I, THOMAS B. CATLETT, A REGISTERED LAND SURVEYOR IN THE STATE OF NEBRASKA, DO CERTIFY THAT I HAVE ACCURATELY SURVEYED THE FOLLOWING SUBDIVISION AND THAT THE SURVEY WAS DONE IN ACCORDANCE WITH THE MOST RECENT MINIMUM STANDARDS FOR PROPERTY SURVEYS, AND THAT PERMANENT MONUMENTS HAVE BEEN FOUND OR PLACED AT EACH OF THE FINAL PLAT CORNERS, AS SHOWN ON THE FINAL PLAT.

A SURVEY OF A REPLAT OF LOTS 5 THROUGH 9 OF CRETE INDUSTRIAL PARK SUBDIVISION AND LOTS 9 AND 10 OF CRETE INDUSTRIAL PARK 1ST ADDITION, LOCATED IN CRETE, SALINE COUNTY, NEBRASKA AND MORE PARTICULARLY DESCRIBED BY METES AND BOUNDS AS FOLLOWS:

**LOTS 1-5 CARDINAL LANE SUBDIVISION**  
BEGINNING AT THE SOUTHEAST CORNER OF SAID LOT 9 OF CRETE INDUSTRIAL PARK 1ST ADDITION, THENCE S88°30'13"W A DISTANCE OF 711.12 FEET; THENCE N38°45'59"W A DISTANCE OF 278.24 FEET TO THE SOUTH RIGHT OF WAY OF CARDINAL LANE; THENCE ON THE SOUTH RIGHT OF WAY OF CARDINAL LANE ON A CURVE TO THE RIGHT, HAVING A RADIUS OF 5580.87 FEET, AN ARC LENGTH OF 888.09 FEET, A CHORD BEARING OF N57°19'27"W, AND A CHORD DISTANCE OF 887.16 FEET, TO THE WEST RIGHT OF WAY OF BITTEN ROAD; THENCE ON THE WEST RIGHT OF WAY OF BITTEN ROAD FOR THE NEXT 3 COURSES; S27°52'57"E A DISTANCE OF 199.98 FEET; THENCE S27°45'30"E A DISTANCE OF 89.98 FEET; THENCE S01°35'50"E A DISTANCE OF 438.82 FEET TO THE SOUTHEAST CORNER OF SAID LOT 9 OF CRETE INDUSTRIAL PARK 1ST ADDITION AND THE POINT OF BEGINNING, SAID TRACT CONTAINING 9.20 ACRES MORE OR LESS.

**LOT 6 CARDINAL LANE SUBDIVISION**  
BEGINNING AT THE SOUTHWEST CORNER OF SAID LOT 10 OF CRETE INDUSTRIAL PARK 1ST ADDITION, THENCE ON THE EAST RIGHT OF WAY OF BITTEN ROAD, N27°29'29"W A DISTANCE OF 280.00 FEET TO THE SOUTH RIGHT OF WAY OF HIGHWAY 33; THENCE ON THE SOUTH RIGHT OF WAY OF HIGHWAY 33, N82°21'08"E A DISTANCE OF 603.55 FEET; THENCE S62°50'08"W A DISTANCE OF 543.21 FEET TO THE EAST RIGHT OF WAY OF BITTEN ROAD AND THE POINT OF BEGINNING, SAID TRACT CONTAINING 1.82 ACRES MORE OR LESS.

SIGNED THIS \_\_\_\_\_ DAY OF \_\_\_\_\_, 2013.

THOMAS B. CATLETT, LS #502

**ACKNOWLEDGMENT OF NOTARY**

STATE OF NEBRASKA  
COUNTY OF SALINE  
SS  
ON THIS \_\_\_\_\_ DAY OF \_\_\_\_\_, 2013, A.D.; BEFORE ME A NOTARY DULY COMMISSIONED AND QUALIFIED IN AND FOR SAID COUNTY, APPEARED THE ABOVE SIGNED PERSON(S) WHO IS/ARE PERSONALLY KNOWN TO ME TO BE THE IDENTICAL PERSON(S) WHOSE NAME(S) IS/ARE AFFIXED TO THE ABOVE DEDICATION ON THIS PLAT AS OWNER(S), PROPRIETOR(S) AND OR TRUSTEE(S) OF THE PROPERTY DESCRIBED IN THE LEGAL DESCRIPTION ON THIS PLAT AND THEY ACKNOWLEDGE THE SIGNING OF SAID DEDICATION TO BE THEIR VOLUNTARY ACTS AND DEEDS, WITNESS MY HAND AND OFFICIAL SEAL OF NEBRASKA IN SAID COUNTY, THE DATE LAST AFORESAID.

MY COMMISSION EXPIRES: \_\_\_\_\_

NOTARY PUBLIC

**APPROVAL OF CRETE CITY PLANNING BOARD**

THIS PLAT OF CARDINAL LANE SUBDIVISION WAS APPROVED BY THE CRETE CITY PLANNING BOARD ON THIS \_\_\_\_\_ DAY OF \_\_\_\_\_, 2013.

ATTEST: \_\_\_\_\_ CHAIRPERSON \_\_\_\_\_ DATE

**APPROVAL OF CRETE CITY COUNCIL**

THIS PLAT OF CARDINAL LANE SUBDIVISION WAS APPROVED BY THE CRETE CITY COUNCIL ON THIS \_\_\_\_\_ DAY OF \_\_\_\_\_, 2013.

ATTEST: \_\_\_\_\_ CITY CLERK \_\_\_\_\_ MAYOR

This Natural Gas Purchase Agreement is between the City of Crete, having an address at 305 E. 13<sup>th</sup> Street, Crete, NE 68333 (Buyer) and Heartland Natural Gas, LLC., having an address at 8540 Executive Woods Drive, Suite 200, Lincoln, NE 68512 (Seller).

**Buyer's Obligations:**

- Provide Seller with advanced notice of any significant change in Buyer's expected natural gas usage.
- Pay all invoices due to Seller at the time of receipt.
- To purchase all natural gas delivered, to the locations listed below according to the terms on Exhibit A (pricing), from Seller for a period of 12 billings months; 12 billing months will not coincide with the signature date of this Agreement due to time needed by the Utility to enroll Buyer for service.

**See Exhibit B for service location details**

**Seller's Obligations:**

- Secure necessary transport capacity in accordance with Buyer's MDQ as defined by the Utility.
- Provide the necessary nominations and balancing procedures for Buyer's locations listed above pursuant to the Utility and pipeline requirements and tariffs.
- Invoice Buyer according to volumes presented to Seller by the local LDC and at the terms set forth in this agreement and any amendment following.

**Volume Obligations:** Seller agrees to provide all necessary gas to meet Buyer's daily requirements. Buyer is making no commitment to consume any certain amount of natural gas during the term of this agreement provided Buyer's Utility account remains. Should buyer's Utility account close indefinitely this will constitute a Default by Buyer.

**Payment:** Seller shall invoice Buyer for all commodity costs associated with supplying natural gas to Buyer's local LDC Citygate. Invoices will be sent to Buyer electronically. Seller's billing cycle will coincide with Buyer's utility meter read cycle. All payments are due immediately upon receipt of invoice and will be considered past due following 20 days after issuance. Any late payment will be assessed either a \$25 charge or a 12% annual interest on any unpaid amounts, whichever is greater. NSF and return payments will be assessed a \$65 fee. Buyer is solely responsible to the local delivery company (LDC) for other charges relating to the delivery of gas to their facility. The local LDC (Utility) will bill Buyer directly for delivery charges to Buyer's location.

**Extension:** Following the original, or amended term, this contract shall continue on a month to month basis. Buyer's month to month price will be determined by the pricing set forth in the original OR most current amended term prior to the month to month continuance. Either party may terminate the month to month extension with 30 days (prior to next meter read) written notice delivered to the other party. Termination prior to original or amended term shall be considered an Event of Default.

**GENERAL CONDITIONS**

**Credit:** Should Buyer submit two (2) late payments within a six (6) month period the Seller has the ability to request up to sixty (60) days security deposit from Buyer. Deposits will be calculated as follows ((MDQ x (Market Value + Seller's fees)). Should Buyer not be able to provide deposit within twenty (20) days from written notice, then Buyer is considered in Default.

**Dispute Resolution:** Buyer and Seller agree to conduct good faith negotiations to resolve any and all disputes, controversies, or claims. Should good faith negotiations fail, Buyer and Seller agree to Arbitration. All disputes, controversies, or claims arising out of or relating to this contract shall be submitted binding arbitration in accordance with the applicable rules of the American Arbitration Association then in effect. Arbitration shall have a limit of two (2) days and shall be held in Lancaster County in the state of Nebraska.

**Assignment:** Neither Party will assign its obligations to this Agreement without written consent from other Party.

**Force Majeure:** Force Majeure shall include, but not be limited to, the following: (i) physical events such as acts of God, landslides, lightning, earthquakes, fires, storms or storm warnings, such as hurricanes or tornados, which result in evacuation of the affected area, floods, washouts, explosions, breakage or accident or necessity of repairs to machinery or equipment or lines of pipe; (ii) weather related events affecting an entire geographic region, such as low temperatures which cause freezing or failure of wells or lines of pipe; (iii) interruption and/or curtailment of Firm transportation and/or storage by Transporters;

(iv) acts of others such as strikes, lockouts or other industrial disturbances, riots, sabotage, insurrections or wars; and (v) governmental actions such as necessity for compliance with any court order, law, statute, ordinance, regulation, or policy having the effect of law promulgated by a governmental authority having jurisdiction. Seller and Buyer shall make reasonable efforts to avoid the adverse impacts of a Force Majeure and to resolve the event or occurrence once it has occurred in order to resume performance.

**Event of Default:** In the Event of Default by Buyer, Buyer is responsible for all previously invoiced amounts, all costs associated with Buyer's pro-rata share of future obligations already committed to by Seller (such obligations include, but are not limited to, capacity reservations, Seller's margin). Seller has 10 business days following the Default date to provide an accounting to Buyer of all amounts due. In the Event of Default by Seller, Buyer's service location(s) are returned to Utility, per Utility tariff, without fees, interruption of service, or delay. In the Event of Default by Seller all unpaid invoices are still owed by Buyer.

**Limitations of Liability:** LIABILITY IS LIMITED TO DIRECT ACTUAL DAMAGES (INCLUDING ANY TERMINATION PAYMENT) AS THE SOLE AND EXCLUSIVE REMEDY, AND ALL OTHER REMEDIES OR DAMAGES AT LAW OR IN EQUITY ARE EXPRESSLY WAIVED, REGARDLESS OF CAUSE. NEITHER PARTY WILL BE LIABLE FOR INCIDENTAL, CONSEQUENTIAL, PUNITIVE, EXEMPLARY OR INDIRECT DAMAGES, LOST PROFITS OR ANY OTHER BUSINESS INTERRUPTION DAMAGES, IN TORT, CONTRACT OR OTHERWISE.

THE PARTIES INDICATE THEIR AGREEMENT TO THE TERMS AND CONDITIONS SET FORTH IN THIS AGREEMENT BY SIGNING BELOW:

**Seller: Heartland Natural Gas, LLC**

**Buyer: City of Crete**

BY: \_\_\_\_\_

BY: \_\_\_\_\_

TITLE: \_\_\_\_\_

TITLE: \_\_\_\_\_

DATE: \_\_\_\_\_

DATE: \_\_\_\_\_

**Exhibit A**

Exhibit A to the base Natural Gas Purchase Agreement the City of Crete, having an address at 305 E. 13<sup>th</sup> Street, Crete, NE 68333 (Buyer) and Heartland Natural Gas, LLC, having an address at 8540 Executive Woods Drive, Suite 200, Lincoln, NE 68512 (Seller).

**PRICING TERMS:**

Buyer's natural gas price will change monthly as determined by Ventura Monthly Index plus Seller's fee of \$ 0.14 per therm for the summer months (Apr-Oct) and \$ 0.18 per therm for the winter months (Nov-Mar).

There are no true ups.

**PLEASE PROVIDE AN EMAIL ADDRESS FOR ELECTRONIC BILLING:**

Name: \_\_\_\_\_ email: \_\_\_\_\_

Name: \_\_\_\_\_ email: \_\_\_\_\_

Name: \_\_\_\_\_ email: \_\_\_\_\_

**Seller: Heartland Natural Gas, LLC**

**Buyer: City of Crete**

BY: \_\_\_\_\_

BY: \_\_\_\_\_

TITLE: \_\_\_\_\_

TITLE: \_\_\_\_\_

DATE: \_\_\_\_\_

DATE: \_\_\_\_\_

**Exhibit B**

Exhibit B to the base Natural Gas Purchase Agreement between the City of Crete, having an address at 305 E. 13<sup>th</sup> Street, Crete, NE 68333 (Buyer) and Heartland Natural Gas, LLC, having an address at 8540 Executive Woods Drive, Suite 200, Lincoln, NE 68512 (Seller).

<b>Service Address</b>	<b>City</b>	<b>State</b>	<b>Zip Code</b>	<b>Account</b>
305 E 13TH ST	Crete	NE	68368	7117708418
210 E 14TH ST	Crete	NE	68368	7515072340
1426 MAIN AVE	Crete	NE	68368	2392338765
1001 S MAIN AVE,*** 015722	Crete	NE	68368	5200449815
1001 S MAIN AVE	Crete	NE	68368	3534066481
485 S MAIN AVE	Crete	NE	68368	4432102811
239 E 13TH ST	Crete	NE	68368	9755616366
701 E 4TH ST,*** 080873	Crete	NE	68368	7206414930
515 E 1ST ST	Crete	NE	68368	6528433113



## Consumption Trend Report CITY OF CRETE

<b>Company</b>	CITY OF CRETE
<b>Address</b>	305 E 13TH ST CRETE NE 68333-2240
<b>HNG Rep</b>	Keith DeMara

Service Address	City	State	Zip Code	Account

Month	Days	Avr	Total
December-11	29	92	2,675
January-12	28	93	2,604
February-12	29	103	2,985
March-12	30	76	2,282
April-12	33	51	1,690
May-12	29	49	1,423
June-12	32	47	1,517
July-12	30	56	1,684
August-12	30	54	1,614
September-12	33	76	2,507
October-12	30	27	800
November-12	34	44	1,483
<b>Total</b>	<b>367</b>	<b>63</b>	<b>23,264</b>

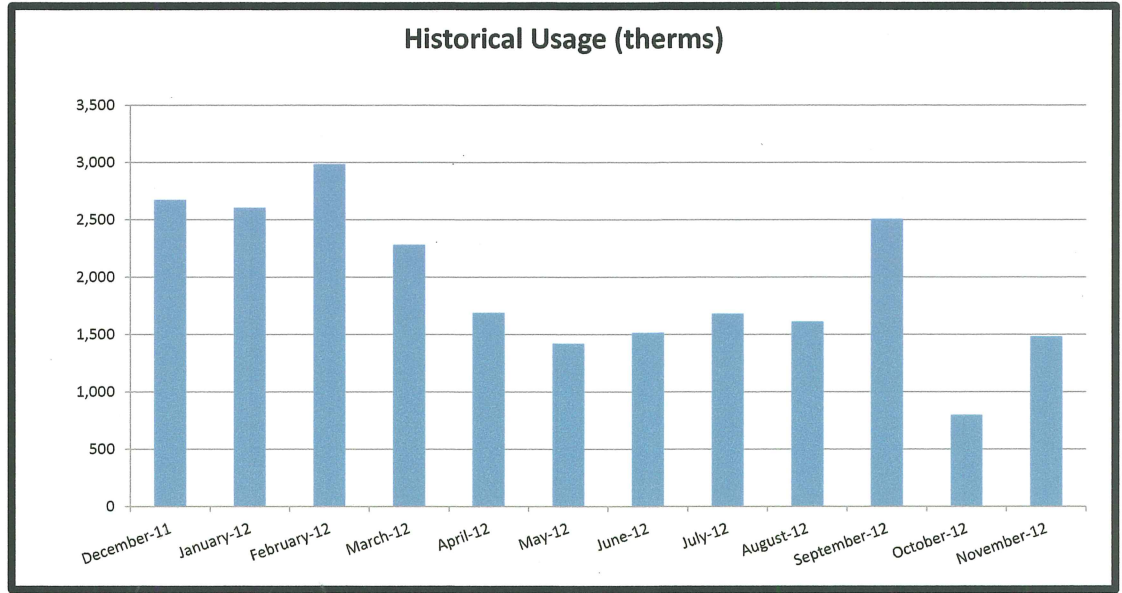

Notes:



**Black Hills Energy**  
**Next 12 Months - Estimate**  
**CITY OF CRETE**  
**Rate Area III - Traditional Sales Service - Commercial**  
**Unit of measurement - "therm"**

BHE Delivery Charge (therm)	\$ 0.17245
Customer Charge	\$ 18.50
Franchise Fee (per therm)	\$ 0.03214
State Regulatory Assessment	\$ 0.10
State	5.5%
City	1.5%

Effective Date	Usage	Gas Cost Component	Total Commodity Cost	Customer Charge (monthly)	Delivery Charge (Base Rate)	Franchise Fee	State Regulatory Assessment	Sub-Total (pre-tax)	State Sales Tax (5.5%)	City Sales Tax	Total Costs
January-13	2,797	\$0.54088	\$1,512.83	\$18.50	\$482.33	\$89.89	\$0.10	\$2,103.65	\$115.70	\$31.55	\$2,250.91
February-13	2,159	\$0.54513	\$1,177.07	\$18.50	\$372.36	\$69.40	\$0.10	\$1,637.43	\$90.06	\$24.56	\$1,752.05
March-13	1,526	\$0.54088	\$825.20	\$18.50	\$263.10	\$49.03	\$0.10	\$1,155.93	\$63.58	\$17.34	\$1,236.85
April-13	1,509	\$0.54513	\$822.88	\$18.50	\$260.31	\$48.52	\$0.10	\$1,150.31	\$63.27	\$17.25	\$1,230.83
May-13	1,466	\$0.54588	\$800.17	\$18.50	\$252.78	\$47.11	\$0.10	\$1,118.66	\$61.53	\$16.78	\$1,196.97
June-13	1,726	\$0.54813	\$946.15	\$18.50	\$297.67	\$55.48	\$0.10	\$1,317.90	\$72.48	\$19.77	\$1,410.16
July-13	1,823	\$0.55438	\$1,010.64	\$18.50	\$314.37	\$58.59	\$0.10	\$1,402.20	\$77.12	\$21.03	\$1,500.35
August-13	2,082	\$0.55613	\$1,157.80	\$18.50	\$359.02	\$66.91	\$0.10	\$1,602.34	\$88.13	\$24.04	\$1,714.50
September-13	911	\$0.55613	\$506.87	\$18.50	\$157.17	\$29.29	\$0.10	\$711.94	\$39.16	\$10.68	\$761.78
October-13	1,449	\$0.56238	\$815.12	\$18.50	\$249.95	\$46.58	\$0.10	\$1,130.25	\$62.16	\$16.95	\$1,209.37
November-13	2,863	\$0.58138	\$1,664.22	\$18.50	\$493.64	\$92.00	\$0.10	\$2,268.46	\$124.77	\$34.03	\$2,427.26
December-13	2,953	\$0.59963	\$1,770.43	\$18.50	\$509.16	\$94.89	\$0.10	\$2,393.09	\$131.62	\$35.90	\$2,560.60
<b>Total</b>	<b>23,264</b>	<b>\$0.55921</b>	<b>\$13,009.38</b>					<b>\$17,992.16</b>	<b>\$989.57</b>	<b>\$269.88</b>	<b>\$19,251.61</b>



**Heartland Natural Gas**  
**Next 12 Months - Estimate**  
**CITY OF CRETE**  
**Rate Area III - Energy Options - Commercial**  
**Unit of measurement - "therm"**

BHE Delivery Charge (therm)	\$ 0.17245
Customer Charge	\$ 18.50
Franchise Fee (per therm)	\$ 0.03214
State Regulatory Assessment	\$ 0.10
State	5.5%
City	1.5%

Effective Date	Usage	Gas Cost Component	Total Commodity Cost	Customer Charge (monthly)	Delivery Charge (Base Rate)	Franchise Fee	State Regulatory Assessment	Sub-Total (pre-tax)	State Sales Tax (5.5%)	City Sales Tax	Total Costs
January-13	2,797	\$0.51650	\$1,444.62	\$18.50	\$482.33	\$89.89	\$0.10	\$2,035.45	\$111.95	\$30.53	\$2,177.93
February-13	2,159	\$0.52075	\$1,124.42	\$18.50	\$372.36	\$69.40	\$0.10	\$1,584.78	\$87.16	\$23.77	\$1,695.71
March-13	1,526	\$0.51650	\$788.00	\$18.50	\$263.10	\$49.03	\$0.10	\$1,118.73	\$61.53	\$16.78	\$1,197.04
April-13	1,509	\$0.48075	\$725.69	\$18.50	\$260.31	\$48.52	\$0.10	\$1,053.12	\$57.92	\$15.80	\$1,126.84
May-13	1,466	\$0.48150	\$705.79	\$18.50	\$252.78	\$47.11	\$0.10	\$1,024.29	\$56.34	\$15.36	\$1,095.99
June-13	1,726	\$0.48375	\$835.02	\$18.50	\$297.67	\$55.48	\$0.10	\$1,206.77	\$66.37	\$18.10	\$1,291.24
July-13	1,823	\$0.49000	\$893.26	\$18.50	\$314.37	\$58.59	\$0.10	\$1,284.83	\$70.67	\$19.27	\$1,374.77
August-13	2,082	\$0.49175	\$1,023.76	\$18.50	\$359.02	\$66.91	\$0.10	\$1,468.30	\$80.76	\$22.02	\$1,571.08
September-13	911	\$0.49175	\$448.19	\$18.50	\$157.17	\$29.29	\$0.10	\$653.26	\$35.93	\$9.80	\$698.99
October-13	1,449	\$0.49800	\$721.80	\$18.50	\$249.95	\$46.58	\$0.10	\$1,036.93	\$57.03	\$15.55	\$1,109.52
November-13	2,863	\$0.55700	\$1,594.42	\$18.50	\$493.64	\$92.00	\$0.10	\$2,198.66	\$120.93	\$32.98	\$2,352.57
December-13	2,953	\$0.57525	\$1,698.44	\$18.50	\$509.16	\$94.89	\$0.10	\$2,321.09	\$127.66	\$34.82	\$2,483.57
<b>Total</b>	<b>23,264</b>	<b>\$0.51597</b>	<b>\$12,003.42</b>					<b>\$16,986.20</b>	<b>\$934.24</b>	<b>\$254.79</b>	<b>\$18,175.23</b>

Commodity Savings	\$ 1,005.96
	7.7%

Total Savings	\$1,076.38
	5.6%



Heartland Natural Gas

Previous 12 Months

CITY OF CRETE

Rate Area III - EO

Unit of measurement - "therm"

BHE Delivery Charge (therm)	\$	0.17245
Customer Charge	\$	18.50
Franchise Fee (per therm)		5%
State Regulatory Assessment	\$	0.10
Taxes	State	0.0%
	City	0.0%

Month	Bill Read Dates	Usage	Usage (Cal Mo)	Gas Cost Component	Total Commodity Cost	Customer Charge (monthly)	Delivery Charge (Base Rate)	Franchise Fee	State Regulatory Assessment (Monthly)	Sub-Total (pre-tax)	State Sales Tax	City Sales Tax	Total Costs
December-11	11/28/11	184	2,675	\$0.54900	\$101.28	\$166.50	\$461.30	\$110.38	\$0.90	\$2,177.77	\$0.00	\$0.00	\$2,177.77
	12/27/11	2,491		\$0.53700	\$1,337.41								
January-12	12/27/11	372	2,604	\$0.53700	\$199.76	\$166.50	\$449.06	\$107.34	\$0.90	\$2,028.40	\$0.00	\$0.00	\$2,028.40
	01/24/12	2,232		\$0.49500	\$1,104.84								
February-12	01/24/12	721	2,985	\$0.49500	\$356.66	\$166.50	\$514.76	\$122.05	\$0.90	\$2,182.16	\$0.00	\$0.00	\$2,182.16
	02/22/12	2,264		\$0.45100	\$1,021.28								
March-12	02/22/12	532	2,282	\$0.45100	\$240.14	\$166.50	\$393.53	\$96.87	\$0.90	\$1,646.74	\$0.00	\$0.00	\$1,646.74
	03/23/12	1,750		\$0.42800	\$748.80								
April-12	03/23/12	410	1,690	\$0.42800	\$175.35	\$166.50	\$291.44	\$73.36	\$0.90	\$1,169.74	\$0.00	\$0.00	\$1,169.74
	04/25/12	1,280		\$0.36100	\$462.19								
May-12	04/25/12	245	1,423	\$0.36100	\$88.57	\$166.50	\$245.40	\$49.43	\$0.90	\$947.67	\$0.00	\$0.00	\$947.67
	05/24/12	1,178		\$0.33700	\$396.87								
June-12	05/24/12	332	1,517	\$0.33700	\$111.83	\$166.50	\$261.61	\$52.54	\$0.90	\$1,056.77	\$0.00	\$0.00	\$1,056.77
	06/25/12	1,185		\$0.39100	\$463.40								
July-12	06/25/12	281	1,684	\$0.39100	\$109.74	\$166.50	\$290.41	\$59.71	\$0.90	\$1,198.41	\$0.00	\$0.00	\$1,198.41
	07/25/12	1,403		\$0.40700	\$571.16								
August-12	07/25/12	323	1,614	\$0.40700	\$131.38	\$166.50	\$278.33	\$60.16	\$0.90	\$1,210.56	\$0.00	\$0.00	\$1,210.56
	08/24/12	1,291		\$0.44400	\$573.29								
September-12	08/24/12	532	2,507	\$0.44400	\$236.11	\$166.50	\$432.33	\$86.91	\$0.90	\$1,722.72	\$0.00	\$0.00	\$1,722.72
	09/26/12	1,975		\$0.40500	\$799.96								
October-12	09/26/12	107	800	\$0.40500	\$43.20	\$166.50	\$137.96	\$34.31	\$0.90	\$687.94	\$0.00	\$0.00	\$687.94
	10/26/12	693		\$0.44000	\$305.07								
November-12	10/26/12	218	1,483	\$0.44000	\$95.96	\$166.50	\$255.74	\$63.15	\$0.90	\$1,260.25	\$0.00	\$0.00	\$1,260.25
	11/29/12	1,265		\$0.53600	\$677.99								
<b>Total</b>		<b>23,264</b>	<b>23,264</b>	<b>\$0.44499</b>	<b>\$10,352.24</b>								<b>\$17,289.13</b>

Supply Savings **\$1,951.25**  
15.86%

Total Savings **\$1,951.25**  
10.14%



**Black Hills Energy**  
**Previous 12 Months**  
**CITY OF CRETE**  
**Rate Area III - Traditional Sales Service - Commercial**  
**Unit of measurement - "therm"**

BHE Delivery Charge (therm)	\$ 0.17245
Customer Charge	\$ 18.50
Franchise Fee (per therm)	5%
State Regulatory Assessment	\$ 0.10
Taxes	State 0.0%
	City 0.0%

Month	Bill Read Dates	Usage (split)	Usage (Cal Mo)	Gas Cost Component	Total Commodity Cost	Customer Charge (monthly)	Delivery Charge (Base Rate)	Franchise Fee	State Regulatory Assessment (Monthly)	Sub-Total (pre-tax)	State Sales Tax	City Sales Tax	Total Costs
December-11	11/28/11	184	2,675	\$0.59575	\$109.91	\$166.50	\$461.30	\$110.38	\$0.90	\$2,317.97	\$0.00	\$0.00	<b>\$2,317.97</b>
	12/27/11	2,491		\$0.58983	\$1,468.98								
January-12	12/27/11	372	2,604	\$0.58983	\$219.42	\$166.50	\$449.06	\$107.34	\$0.90	\$2,254.09	\$0.00	\$0.00	<b>\$2,254.09</b>
	01/24/12	2,232		\$0.58731	\$1,310.88								
February-12	01/24/12	721	2,985	\$0.58731	\$423.17	\$166.50	\$514.76	\$122.05	\$0.90	\$2,563.13	\$0.00	\$0.00	<b>\$2,563.13</b>
	02/22/12	2,264		\$0.58987	\$1,335.75								
March-12	02/22/12	532	2,282	\$0.58987	\$314.09	\$166.50	\$393.53	\$96.87	\$0.90	\$2,034.27	\$0.00	\$0.00	<b>\$2,034.27</b>
	03/23/12	1,750		\$0.60724	\$1,062.39								
April-12	03/23/12	410	1,690	\$0.60724	\$248.78	\$166.50	\$291.44	\$73.36	\$0.90	\$1,540.63	\$0.00	\$0.00	<b>\$1,540.63</b>
	04/25/12	1,280		\$0.59333	\$759.64								
May-12	04/25/12	245	1,423	\$0.59333	\$145.57	\$166.50	\$245.40	\$49.43	\$0.90	\$1,038.08	\$0.00	\$0.00	<b>\$1,038.08</b>
	05/24/12	1,178		\$0.36537	\$430.28								
June-12	05/24/12	332	1,517	\$0.36537	\$121.25	\$166.50	\$261.61	\$52.54	\$0.90	\$1,103.27	\$0.00	\$0.00	<b>\$1,103.27</b>
	06/25/12	1,185		\$0.42229	\$500.48								
July-12	06/25/12	281	1,684	\$0.42229	\$118.52	\$166.50	\$290.41	\$59.71	\$0.90	\$1,253.82	\$0.00	\$0.00	<b>\$1,253.82</b>
	07/25/12	1,403		\$0.44023	\$617.79								
August-12	07/25/12	323	1,614	\$0.44023	\$142.11	\$166.50	\$278.33	\$60.16	\$0.90	\$1,263.29	\$0.00	\$0.00	<b>\$1,263.29</b>
	08/24/12	1,291		\$0.47653	\$615.30								
September-12	08/24/12	532	2,507	\$0.47653	\$253.41	\$166.50	\$432.33	\$86.91	\$0.90	\$1,825.13	\$0.00	\$0.00	<b>\$1,825.13</b>
	09/26/12	1,975		\$0.44809	\$885.07								
October-12	09/26/12	107	800	\$0.44809	\$47.80	\$166.50	\$137.96	\$34.31	\$0.90	\$720.52	\$0.00	\$0.00	<b>\$720.52</b>
	10/26/12	693		\$0.48037	\$333.06								
November-12	10/26/12	218	1,483	\$0.48037	\$104.76	\$166.50	\$255.74	\$63.15	\$0.90	\$1,326.16	\$0.00	\$0.00	<b>\$1,326.16</b>
	11/29/12	1,265		\$0.58115	\$735.10								
<b>Total</b>		23,264	23,264	<b>\$0.52886</b>	<b>\$12,303.49</b>							<b>\$19,240.38</b>	

January 9, 2013

Tom Ourada  
Director of Public Works  
City of Crete  
PO Box 86  
Crete, NE 68333

RE: Cost of Service Update Letter Proposal

Dear Tom:

JK Energy Consulting, LLC (JKEC) is pleased to submit this proposal to prepare a limited Cost of Service update focusing on power supply costs for the City of Crete (City) and its electric utility (Utility). This proposal provides the scope of services, cost proposal, deliverables and proposed schedule.

### ***Background***

In early 2012, JKEC prepared a Cost of Service Update for the City. Based on the analysis done at that time, JKEC recommended the City implement a rate increase of 4.2% in October 2012 and a 4.1% rate increase in October 2013. It appears that the City's power supplier, the Municipal Energy Agency of Nebraska (MEAN), plans to implement rate increases of 9.75% in 2013 and 2014 (effective April 1 of each year). Based on the fact that the MEAN rate increase is almost double what was anticipated when the cost of service update was prepared less than a year ago, the City would like to re-evaluate rates for 2013 and 2014 to ensure sufficient revenues are being collected to pay for projected operating expenses and the ongoing debt service.

### ***Proposed Scope of Services***

**Task 1: Data Collection.** This task would involve collecting operating expense, purchased power and retail customer usage data necessary to complete the analysis. The City would need to provide JKEC with the following data:

1. Copies of wholesale purchased power invoices from the Municipal Energy Agency of Nebraska (MEAN) and Western Area Power Administration (WAPA).
2. Updated rate schedules for MEAN and, if applicable, WAPA.

**Task 2: Calculate Revenue Requirements for FY 2012.** This task would involve comparing projected expenses to the most recent rate study, taking into account the change in MEAN's projected rates for April 2013. The proposed rate increase for FY 2013 would be reviewed to determine if it is adequate to cover projected operating expenses. Modifications to the proposed

rate change would be recommended, if necessary. If necessary based on the planned increases in power supply costs, a rate change for FY 2014 would be prepared, if necessary.

**Task 3: Update Rate Schedule.** This task involves preparing a rate schedule to implement the proposed rate change identified in Task 2, if appropriate. The proposed rate schedule format from the most recent rate study would form the basis for the updated rate schedule.

**Task 4: Prepare Rate Comparisons.** This task would involve preparing rate comparisons for typical residential customers. Projected costs under existing and proposed rates would be calculated to determine projected changes in monthly and annual bills.

**Task 5: Summarize Findings.** This task would involve preparing a letter report, summarizing the findings of the analysis. An updated rate ordinance would also be prepared to implement proposed rate changes, if any.

### ***Deliverables***

1. One electronic copy of the letter report and work papers in Adobe Acrobat (.pdf) format.
2. One electronic copy of proposed rate ordinance in Microsoft Word format.

### ***Fee***

The cost to provide the above-listed Scope of Services would be \$1,500, which includes all billable time and out-of-pocket travel expenses. No travel expenses are anticipated. If a meeting with the Utility Committee is necessary, time and actual expenses would be billed in addition to the proposed fee.

Invoices are due upon receipt and would be sent via email. Interest would accrue on unpaid balances after 30 business days at a rate of 1% per month.

### ***Schedule***

A letter report would be completed within 45 days of receipt of all requested data.

### ***City Responsibility***

The City would be responsible for providing requested data (see Task 1 above) on a timely basis, including timely response to any questions or clarifications regarding the provided data.

### ***Additional Services***

Any services not included in the Scope of Services would only be provided upon written agreement (email authorization is acceptable) by the City and JKEC. Such services would be billed at JKEC's Standard Billing Rate Schedule (see Attachment 1).

Tom Ourada  
January 9, 2013  
Page 3

JKEC appreciates the opportunity to provide this proposal to you. If it is acceptable, please print two copies of this letter, sign both copies, return one copy to JKEC and retain the other for your records.

Sincerely yours,



John A. Krajewski, P.E.  
JK Energy Consulting, LLC

JAK/kam

PROPOSAL ACCEPTED:

By: \_\_\_\_\_

Name: \_\_\_\_\_

Title: \_\_\_\_\_

Date: \_\_\_\_\_

## ATTACHMENT 1 – STANDARD BILLING RATE SCHEDULE

The following rate schedule will be used to determine monthly billings, unless an alternative fixed-fee or other billing arrangement is specified. It will also be used to determine charges for additional services requested by the City, but not included in the agreed-upon Scope of Services.

<u>Billable Item</u>	<u>Billing Rate</u>
John A. Krajewski, P.E.	\$125.00 per hour
Administrative staff	\$50.00 per hour
Mileage	IRS standard rate for business use 2013: \$0.565/mile
Lodging, meals, other travel	Actual cost, without markup
Copies, faxes, postage, phone, other office overheads	Included in hourly billing rate
Outside professional services	Actual cost, plus 10%

**CITY OF CRETE, NEBRASKA**  
**ECONOMIC DEVELOPMENT ADVISORY BOARD**  
**JANUARY 23, 2013**

Notice of the meeting was given by posting, the appointed method for giving notice as shown by the attached notice, at the following locations:

City Hall, 243 East 13<sup>th</sup> Street  
US Post Office, 1242 Linden Avenue  
City Bank & Trust, 1135 Main Avenue

Advance notice of the meeting also given to the committee members. Pursuant to Section 84-1412(8) of the Nebraska Open Meetings Act, the City has posted a current copy of the Open Meetings Act, Laws of the State of Nebraska, in the back of the Council Chambers. Additional copies are available to read. The committee may consider items listed on the agenda in random order. All proceedings shown were taken while the meeting was open to the attendance of the public.

The meeting was called to order by Chairperson Shaylene Smith. Other board members present were Ken Marvin, Eric Rasgorshek and Amy Vertin. Members absent were Jacque Pomajzl, Victor Alarcon and Jody Pence. A quorum being present, the meeting was called to order. Also present were City Clerk Jerry Wilcox and representatives of grant applicants.

**Financial Report** – The total funds available were reviewed. Also reviewed were the funds already obligated for the remainder of the year. Shaylene Smith stated that with the funds available, all the requests would not be funded in full.

**Presentations:**

**Isis Theater** – Thom Reeves was present to explain that the theater was not a profitable venture, but was acquired to get the 100 year history of a movie theater in Crete alive. Changes in the movie industry now require theaters to have digital equipment. 35 mm films are not being made in the numbers as before, so there are fewer movies to go around. Many smaller theaters are closing instead of updating the equipment. The \$42,786.93 request is 1/2 of the funds needed to buy the digital equipment, upgrade the sound system and make some structural changes required to get the new equipment in.

**VFW** – Representatives of the VFW were present to request funds to replace the compressor on the walk in cooler and the other equipment in hopes of cutting the electricity costs in half. Some marketing to get more of the public interested in eating at the hall would be beneficial.

**City of Crete** – Tom Ourada explained that the City is requesting \$11,063 to build one of the dugouts required at the Legion Baseball Field in Tuxedo Park, owned by the City and operated by the American Legion. The American Legion has generated the funds required to build the other dugout.

Ken Marvin made a motion for the board to go into executive session at 12:45 PM to discuss the financial information available for each application. Eric Rasgorshek seconded the motion. Voting aye: Smith, Marvin, Rasgorshek, Vertin. Voting no: None. Absent: Alarcon, Pence and Pomajzl. Motion carried. Smith stated that the board would go into executive session to discuss the financial information made available with the applications.

Ken Marvin made a motion for the board to exit executive session at 1:05 PM. Eric Rasgorshek seconded the motion. Voting aye: Smith, Marvin, Rasgorshek, Vertin. Voting no: None. Absent: Alarcon, Pence and Pomajzl. Motion carried. Smith stated that the board met in executive session to discuss the financial information made available with the applications and no action was taken.

**Recommendations for Funding:**

**Carl's Boot Repair** – Eric Rasgorshek moved that the board recommend to the City Council approval of the following funds:

\$2,595	Equipment
\$ 250	Technology upgrades
<u>\$5,000</u>	Veteran training
\$7,845	

with the verification of purchases and the verification of a veteran's training program participation. Ken Marvin seconded the motion. Voting aye: Smith, Marvin, Rasgorshek, Vertin. Voting no: None. Absent: Alarcon, Pence and Pomajzl. Motion carried.

**City of Crete** – Ken Marvin moved that the board recommend to the City Council approval of the funds for the construction of a dugout at Tuxedo Park in the amount of \$11,063. Eric Rasgorshek seconded the motion. Voting aye: Smith, Marvin, Rasgorshek, Vertin. Voting no: None. Absent: Alarcon, Pence and Pomajzl. Motion carried.

**Isis Theater** – Amy Vertin moved that the board recommend to the City Council approval of the funds for equipment in the Isis Theater in the amount of \$43,000 upon verification that the matching funds have been raised. Ken Marvin seconded the motion. Voting aye: Smith, Marvin, Rasgorshek, Vertin. Voting no: None. Absent: Alarcon, Pence and Pomajzl. Motion carried.

**Tutti Frutti** – Eric Rasgorshek moved that the board recommend to the City Council approval of the following funds:

\$10,000	Equipment
<u>\$ 2,500</u>	Technology upgrades
\$12,500	

with the verification of purchases. Amy Vertin seconded the motion. Voting aye: Smith, Marvin, Rasgorshek, Vertin. Voting no: None. Absent: Alarcon, Pence and Pomajzl. Motion carried.

**VFW** – Eric Rasgorshek moved to table this application until a legal opinion is obtained about making a grant to a restricted membership organization. Ken Marvin seconded the motion. Voting aye: Smith, Marvin, Rasgorshek, Vertin. Voting no: None. Absent: Alarcon, Pence and Pomajzl. Motion carried.

**Winterlude** – Ken Marvin moved that the board recommend to the City Council approval of \$3,500 for advertising the Winterlude Festival of 2012 with the understanding that if funds are requested again, it will be done in a timely fashion and funds would be planned to be spent locally. Eric Rasgorshek seconded the motion. Voting aye: Smith, Marvin, Rasgorshek, Vertin. Voting no: None. Absent: Alarcon, Pence and Pomajzl. Motion carried.

**Whistle Stop Cafe** – Eric Rasgorshek moved to table this application until information about a permanent location for the mobile coffee shop with a lease is obtained. Amy Vertin seconded the motion. Voting aye: Smith, Marvin, Rasgorshek, Vertin. Voting no: None. Absent: Alarcon, Pence and Pomajzl. Motion carried.

**Program Director Job Description** – The part time position is now vacant and discussion has been that it might be beneficial to make the position full time. The job description developed for a full time position was reviewed. An addition was discussed to encourage the individual to develop funding for continued operation of the position. The position would be a City employee and eligible for City benefits. It has been discussed that office space might be available at City Hall. An amendment to the plan to provide up to 10% of the funding for administration was discussed. Amy Vertin moved to recommend to the City Council for approval of the job description with the change discussed and amending the plan to allow for up to 10% of the funds for administration. Eric Rasgorshek seconded the motion. Voting aye: Smith, Marvin, Rasgorshek, Vertin. Voting no: None. Absent: Alarcon, Pence and Pomajzl. Motion carried.

Ken Marvin moved for adjournment at 1:25 PM.

Recorded by Jerry Wilcox

**CITY OF CRETE – ECONOMIC DEVELOPMENT  
APPLICATION FOR FUNDS**

223 W 13<sup>th</sup> St – Crete NE 68333  
402-826-2566

Please Answer Each Question (If Question Does Not Apply – Mark N/A). Please Type or Print Clearly.

**Please Note:** The Information Contained in this portion of the document is Public Information and will **NOT** be Considered Confidential.

**A. APPLICANT INFORMATION**

Name of Entity Applying for Assistance: Carl's Boot and Shoe Repair  
Business Address: 1344 Main Street

(City) Crete (State) NE (Zip Code) 68333

Contact Person: Carl DeHaven Fax Number: NA, Phone Number: 402-826-6163, Email Address: NA,  
Crete residence: 2489 Boswell Apt C, Crete NE 68333

Federal Tax ID Number: I will use my Social Security Number until a Federal Tax ID is issued. My Social Security number will be attached to a page in the application that will not be made public.

Type of Entity:  Start-Up  Buyout  Existing

If Existing, Number of Years in Business in Crete: \_\_\_\_\_

**Business Classification: (Please Choose One)**

- |   |   |   |
|---|---|---|
| <input checked="" type="checkbox"/> Retail      | <input type="checkbox"/> Manufacturing      | <input type="checkbox"/> Research & Development |
| <input type="checkbox"/> Headquarter            | <input type="checkbox"/> Telecommunications | <input type="checkbox"/> Tourism                |
| <input type="checkbox"/> Warehouse/Distribution | <input type="checkbox"/> Government         | <input type="checkbox"/> Other                  |

**Business Type: (Please Choose One)**

- |  |  |                                      |
|--|--|--------------------------------------|
| <input checked="" type="checkbox"/> Proprietorship | <input type="checkbox"/> Corporation         | <input type="checkbox"/> Partnership |
| <input type="checkbox"/> LLC                       | <input type="checkbox"/> Governmental Entity | <input type="checkbox"/> Other       |

Does the Company have a Parent or Subsidiaries?  Yes  No

If Yes, Please List Name: \_\_\_\_\_

Address: \_\_\_\_\_  
(City) 23 (State) (Zip Code)

Ownership Identification: Please List all Officers, Directors, Partners, Owners, Co-owners and Stockholders.

Full Name	Title	Ownership Percentage
Carlton Duffalon	Proprietor	100%

Which type of assistance is the entity applying for?

Grant       Loan Guarantee If so, Lender? \_\_\_\_\_       Other

Explain: \_\_\_\_\_

What is the general purpose of the request (must be an allowed LB840/Economic Dev. Plan Project)?

- New Development     New Business Startup     Building Renovation     Public Works  
 Professional/Employee Recruitment     Promotion/Tourism     Job Training  
 Technology     Working Capital     Low - Moderate Income Housing     Plan Management

Does the business qualify to receive any incentives from the State of Nebraska?  Yes  No  DK

Has the business applied for any incentives from the State of Nebraska?  Yes  No

If yes, please explain: \_\_\_\_\_

Employee Information: (FTE = Full-Time Equivalent = 2,080 Hours/Per Year)

Number of Existing Full-Time Equivalent Employees: 2.25: Carlton will be involved as the full time employee \_

Number of Full-Time Equivalent Positions to Be Created: Plans include developing a training program for shoe repair and I will identify a disabled veteran to be an apprentice who will work 1/2 time to full time. The 0.25% employee would be a part time employee for shoe shining and other work assignments if the business grows and there is a need for these services.

Will all of the Full-Time Equivalent Positions be Physically Located within the City of Crete, their Two-Mile Extraterritorial Jurisdiction or on Land Held in the Name of the City of Crete?  Yes  No

If no, please explain: \_\_\_\_\_

Does the Company Employ Any Seasonal Employees?  Yes  No Carl will be open to part time employment if business develops to require more than the identified 2.25 employees.

If Yes, How Many: I would expect three as the maximum number of seasonal employees. Once again this growth would be based on future growth of the business and justified by continued business generated needs to support the growth of the business.

(Seasonal employees must work for at least three continuous months and the position must reoccur annually)

**B. PROJECT INFORMATION**

Please provide a Brief Project Description: I have been a professional Shoe Repair Technician for sixty years in the state of California. I retired in 2009 and relocated to Crete, Nebraska in September of 2009. I have been active in the shoe repair business since I relocated to Crete as a voluntary assistant to the former owner of the Brand Shoe Repair. Recently the Shoe Repair Shop in Crete was closed following the owner relocating his shop outside of Crete. I evaluated my options related to reopening the shop but learned that all of the equipment was moved to the new location. My plan calls for the renovation of the shop by completing the following tasks; 1) general cleaning and painting the interior shop walls, ceiling and floors, 2) relocating shoe repair equipment from Reno, Nevada, 3) rebuilding, repairing or performing maintenance to the equipment to prevent downtime when the shop opens, 4) purchase a finishing machine and relocate it to Crete from Fremont, 5) installing all of the equipment (the prior business located in this building was a Shoe Repair Shop so little to no electrical or building modifications are required to set up the shop, 5) order supplies, 6) advertise and promote the new shop in Crete and the surrounding communities by offering coupons worth \$10.00 off any shoe service over \$40.00. My intent is to work with the Disabled Veterans Group to set up a program for training vets to become shoe repair technicians and potential owners of the business so it will remain a viable service for the citizens of Crete. I think that two people would be the maximum number of apprentices that could be trained during a calendar year.

Use of Funds	Total Project Cost	Econ Dev Funds Requested
Land or Facility Acquisition (Lease a shop in Crete)	\$ 7,200.00 per year	\$ 3,600.00
Facility Renovation (cleaning and painting the shop)	\$ 600.00	\$ 300.00
New Facility Construction	\$ 0	\$ 0.00
Machinery / Equipment Acquisition & relocation	\$ 5,190.00	\$ 2,595.00
Business / Employee Recruitment Activities	\$	\$
Technology Costs	\$ 500.00	\$ 250.00
Small Business Development	\$	\$
Working Capital (Includes Inventory)	\$ 5,000.00	\$ 2,500.00
Job Training -Apprentice Program for Disabled Vets.	\$ 10,000.00	\$ 5,000.00
Other Advertisements and coupon discounts	\$ 3,500.00	\$ 1,750.00
Total Project Cost	\$ 31,990.00	\$ 15,995.00
	Total LB840 Funds Requested:	\$ 15,995.00

**C. FUNDING SOURCES AND EQUITY INJECTION**

If Borrowing, Name of Lender: None NA \_\_\_\_\_

Loan Amount: \_\_\_\_\_ Loan Term (Years): \_\_\_\_\_

Amount Injected into the Project by Business/Partners/Owners: \$15,995.00 by the owner. \_\_\_\_\_

Other Funding Source(s) and Amount(s): Providing Machinery and Equipment as in kind contributions in place of cash \$5,190.00 (shoe repair equipment owned or being purchased for the shop).

**C. PROJECT LOCATION**

- Within the Crete City Limits?  Yes  No
- Within the Crete Two-Mile Jurisdiction?  Yes  No
- Land Owned by the City of Crete?  Yes  No
- Not Located in Crete but for area benefit?  Yes  No

If Not in City Jurisdiction, please explain local benefit: \_\_\_\_\_

**D. ATTACHMENTS: - Please Include the Attachments that Apply to Your Entity**

**Please Note:** The Information provided pursuant to this Section **Will** be Deemed Confidential and will not be Available for Public Disclosure.

- Brief Description of the Business
- Resumes of all Owners/Co-Owners/Directors/Partners/Stockholders
- For Existing Businesses – Three (3) Yearly Financial Statements
- For Existing Businesses – Current Financial Statements (Less Than Sixty (60) Days Old)
- For Start-Up Businesses – Current Business Plan
- For Start-Up Businesses – Three Year Projections
- For Existing Businesses - List of Current Obligations (Include Company Names and Amounts)
- \* Tax Returns – Previous Three (3) Years – Personal Tax Returns May be Required for Proprietorship
- Letter from Lending Institution if applicable
- If a Corporation, LLC or Other Legal Entity - Copy of Organizational Documents (Articles, Bylaws)
- Please Note that Other Financial Documents May Be Required

\* My current work status is as a retired person. I have not been required to file Tax Returns for last 3 years. years.

Please see attached documentation of information required.

**E. APPLICANT SIGNATURE**

I certify that the information contained in this application and all attachments are correct to the best of my knowledge. By signing below, I authorize the City of Crete or their contracted representative to check my credit and the credit of all who are listed within this application. I understand that I must update my credit information if my financial situation changes.

*Carlton R. DeHaven Sr*

Applicant's Signature

*Aug 5 - 2012*

Date

## **ATTACHMENTS**

### **Description of the Business**

Carl's Boot & Shoe Repair will focus on providing a service to the citizens of Crete that is currently not available to them. The shop will be a full service repair facility which will focus on the standard shoe services for all family members which includes the following: replacement of heels and soles, shoe shining services, repairing all surface blemishes, repairing purses, luggage repairs, and zipper replacements. These services will be provided to the residents of Crete at fair and reasonable prices. The shop will be the only shoe repair shop located in Crete.

### **Resume of Carlton DeHaven**

I started my career working as a Shoe Shine Boy working in California, throughout my career which exceeded sixty years, I advanced in the shoe repair business until I became the owner of the business in 1999. I owned and operated the business in Ukiah, California for thirteen years until relocating in 2002 to the Reno, Nevada area.

I relocated to Reno, Nevada in 2002 and worked with local shoe repair shops until 2009.

I relocated to Crete, Nebraska in September of 2009, where I worked as a volunteer in Brand Shoe Repair.

When the existing Shoe Repair business closed, I began evaluating my options and decided to pursue a grant from the community of Crete to open a new Shoe Repair Shop in Crete.

### **Current Business Plan**

My immediate plans for the business are as follows:

1. Relocate my shoe repair equipment from Nevada to Crete, Nebraska within the next sixty days.
2. Purchase a used finishing machine for sanding, trimming and polishing of shoes and have it moved to Crete from Fremont, Nebraska.
3. I have negotiated and signed a lease for a location for the shop in Crete. The future site for my shop is the former location of the Shoe Repair facility that closed in Crete. This location was selected because it did not require extensive modifications to be adapted to a functional Shoe Repair shop since it was a functional shop for years. The owner of the building and I reached terms on the lease that included all utilities along with the ability to adjust the terms of the lease if the electrical bill remains below the estimated usage contained in the current lease.
4. Evaluated the need for a Shoe Repair business in Crete and determined that fair and reasonable pricing for my services could lead to a profitable business.
5. Evaluated the requirements for submitting a business development grant for starting a new business in Crete.
6. Developed a time line for relocation, preventive maintenance on the relocated equipment and located a finishing machine that I have a purchase agreement with the owner to buy the equipment and have it delivered to the location of my new shop in Crete.
7. Identified the potential suppliers of shoe repair materials that service Southeastern Nebraska.
8. Initiated contact with the shoe supply vendor to determine the level of service that is available to a start up shoe repair business.
9. Plan to submit a grant application in early August to Crete for Economic Development Funds.

## **Marketing**

My marketing plans include advertising in printed media that serves Crete and the immediate surrounding communities. Based on past operations of a shoe repair business the best marketing plan is to heavily rely on **Word of Mouth referrals from satisfied customers**. A coupon for \$10.00 off of shoe repairs costing \$40.00 or more will be the initial attempt to generate customers for the new shoe repair shop. By offering fair and reasonable prices for my services, I expect to develop a local reputation as being an honest businessman.

## **Personnel**

All employees required to support the business will be hired from the Crete area whenever possible. The only exception may come from the apprentice position. The first step in the apprentice program is to find an interested person that is eligible for VA training programs which would pay the individual while participating in learning a skill that will make them self sufficient in today's society.

## **Business Insurance**

I have discussed the type and costs of insurance with my current insurance man. The company that he represents has a general liability policy for small businesses that can be purchased for approximately \$30.00 per month.

## **Capital Equipment**

I currently own or have options on the machinery and equipment required to open and operate a shoe repair facility. I plan to purchase a cash register and other business related technological equipment that will be needed for the business. The majority of the technological equipment will be justified by shop cash flow and recordkeeping requirements to document earnings for tax purposes.

## **Financial projections**

First year - my immediate plans are to take a minimal salary from the business not to exceed \$400.00 a month. The balance of funds (after expenses are paid) will be reinvested into the business to buy equipment, hand tools or supplies to help the business grow. Gross income generated during the first year is projected to be \$18,000.00.

The second and third year currently project gross income at \$21,000.00 and \$24,000.00. These numbers are estimates that are conservative numbers that should be obtainable.

Assumptions used in the generation of the above numbers included the following fixed costs:

1. shop rental
2. all utilities are included in the rent agreement with the building owner. If electricity costs are below the projections used to calculate the rent the landlord will reduce the monthly costs based on the lower cost of the electricity.
3. Carl is limiting his income from the business to \$400.00 a month to provide funding for reinvestment in the business.
4. Apprentice costs were based upon the identification of a person that is a disabled vet that is eligible for training assistance funds while enrolled in the apprentice program. Carl is not charging for his time for instruction and recordkeeping to satisfy the government requirements.
5. Customer demand for services located within the Crete boundaries has been conservatively estimated to calculate the anticipated gross income.

**Supplier Identification**

Baltor and Sons is a wholesale supplier of shoe repair materials and equipment. They are located in San Francisco, California. Local vendors that serve the Crete area will be identified and evaluated based upon comparison to Baldor's cost and service response times.

**Social Security Number: 562-44-4456**

# United States Citizenship Attestation Form

For the purpose of complying with Neb. Rev. Stat. §§ 4-108 through 4-114, I attest as follows:

<input checked="" type="checkbox"/> I am a citizen of the United States.
— OR —
<input type="checkbox"/> I am a qualified alien under the federal Immigration and Nationality Act, my immigration status and alien number are as follows: _____, and I agree to provide a copy of my USCIS documentation upon request.

I hereby attest that my response and the information provided on this form and any related application for public benefits are true, complete, and accurate and I understand that this information may be used to verify my lawful presence in the United States.

PRINT NAME	<u>CARLTON Royce DeHAVEN Sr.</u> <small>(first, middle, last)</small>
SIGNATURE	<u><i>Carlton Royce DeHaven Sr.</i></u>
DATE	<u>Aug 5 - 2012</u>

Economic Development Program  
Recommendation Form

Applicant: Carl DeHaven

Public Hearing Date: 1/30/13 (previously tabled 9/11/12)

Criteria Met:

- Allowed Activity: services/retail (#1-15)
- Eligible Entity: Qual Business (#1-11)
- Entity: Part startup/  
Part Buyout (startup, buyout, existing)

Request:

- Application Amount: \$15,995 (grant or income guarantee)
- Term: Lump Sum (lump sum or number of years)
- Matching Funds: self/VA Program: \_\_\_\_\_
- Economic Impact: \_\_\_\_\_ (dollars) and/or 2.25 (jobs) and/or  
only such  
new service provider (other value)  
in area

Recommendation:

- Recommend funding \$ \_\_\_\_\_
- Recommend partially funding \$ 2845 for equipment, startup now
- Do not recommend funding \$5000 for job training subject to VA or other funding and hire

Expenditure Category:  Infrastructure/Real Estate Purchase/Development verification  
 Promotion/Tourism  
 Business/Professional Recruitment & Retention

Council Meeting date: \_\_\_\_\_

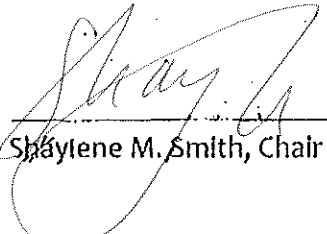
  
Shaylene M. Smith, Chair

**CITY OF CRETE – ECONOMIC DEVELOPMENT  
APPLICATION FOR FUNDS**

223 W 13<sup>th</sup> St – Crete NE 68333  
402-826-2566

Please Answer Each Question (If Question Does Not Apply – Mark N/A). Please Type or Print Clearly.

**Please Note:** The Information Contained in this portion of the document is Public Information and will **NOT** be Considered Confidential.

**A. APPLICANT INFORMATION:**

Name of Entity Applying for Assistance: City of Crete

Business Address: 243 East 13th Street, Crete, NE 68333

Contact Person: Tom Ourada (City) (State) (Zip Code)  
Telephone Number: 402 826-4312

Fax Number: 402 826-4334 Email Address: tourada@crete-ne.gov

Federal Tax ID Number: 476006154

Type of Entity:       Start-Up       Buyout       Existing

If Existing, Number of Years in Business in Crete: over 100 years

**Business Classification: (Please Choose One)**

- |   |  |   |
|---|--|---|
| <input type="checkbox"/> Retail                 | <input type="checkbox"/> Manufacturing         | <input type="checkbox"/> Research & Development |
| <input type="checkbox"/> Headquarter            | <input type="checkbox"/> Telecommunications    | <input type="checkbox"/> Tourism                |
| <input type="checkbox"/> Warehouse/Distribution | <input checked="" type="checkbox"/> Government | <input type="checkbox"/> Other                  |

**Business Type: (Please Choose One)**

- |   |   |                                      |
|---|---|--------------------------------------|
| <input type="checkbox"/> Proprietorship | <input type="checkbox"/> Corporation                    | <input type="checkbox"/> Partnership |
| <input type="checkbox"/> LLC            | <input checked="" type="checkbox"/> Governmental Entity | <input type="checkbox"/> Other       |

Does the Company have a Parent or Subsidiaries?     Yes       No

If Yes, Please List Name: \_\_\_\_\_

Address: \_\_\_\_\_  
(City) (State) (Zip Code)

Ownership Identification: Please List all Officers, Directors, Partners, Owners, Co-owners and Stockholders.

<i>Full Name</i>	<i>Title</i>	<i>Ownership Percentage</i>
Roger Foster	Mayor	N/A

Which type of assistance is the entity applying for?

Grant       Loan Guarantee If so, Lender? \_\_\_\_\_       Other

Explain: \_\_\_\_\_

What is the general purpose of the request (must be an allowed LB840/Economic Dev. Plan Project)?

- New Development     New Business Startup       Building Renovation       Public Works  
 Professional/Employee Recruitment       Promotion/Tourism       Job Training  
 Technology     Working Capital       Low - Moderate Income Housing       Plan Management

Does the business qualify to receive any incentives from the State of Nebraska?  Yes  No  DK

Has the business applied for any incentives from the State of Nebraska?  Yes  No

If yes, please explain: \_\_\_\_\_

Employee Information: (FTE = Full-Time Equivalent = 2,080 Hours/Per Year)

Number of Existing Full-Time Equivalent Employees: \_\_\_\_\_

Number of Full-Time Equivalent Positions to Be Created: \_\_\_\_\_

Will all of the Full-Time Equivalent Positions be Physically Located within the City of Crete, their Two-Mile Extraterritorial Jurisdiction or on Land Held in the Name of the City of Crete?  Yes  No

If no, please explain: \_\_\_\_\_

Does the Company Employ Any Seasonal Employees?  Yes  No

If Yes, How Many: \_\_\_\_\_  
 (Seasonal employees must work for at least three continuous months and the position must reoccur annually)

**B. PROJECT INFORMATION:**

Please provide a Brief Project Description:

The City of Crete is requesting funding to be applied toward renovation of the Legion Field dugouts.

Over the past five years the City of Crete has had to cut funding for some services, including reductions in the Parks Department. Although the City does fund maintenance activities at the Legion Field, special improvements are evaluated economically and while the appearance of the existing dugouts are not attractive they are still serviceable. Given that, the City has opted to use its limited resources on more pressing needs.

In the past the Legion Board has done a very good job of investing in improvements on the field that are above the level the City maintains. This partnership has worked very well in the past and the Legion Board wishes to continue to do so, in this case by partially funding new dugouts.

Below, you will see that the Legion Board would like to build one new dugout and the City would ask assistance from the LB840 Committee to approve funding for the other dugout.

Attached are the price estimates and layout of

Use of Funds	Total Project Cost	Econ Dev Funds Requested
Land or Facility Acquisition	\$	\$
Facility Renovation - Downtown revitalization and redevelopment	\$ 22,126	\$ 11,063
New Facility Construction	\$	\$
Machinery / Equipment Acquisition	\$	\$
Business / Employee Recruitment Activities	\$	\$
Technology Costs	\$	\$
Small Business Development	\$	\$
Working Capital (Includes Inventory)	\$	\$
Job Training	\$	\$
Other	\$	\$
Total Project Cost	\$	
	Total LB840 Funds Requested:	\$ 11,063

**C. FUNDING SOURCES AND EQUITY INJECTION:**

If Borrowing, Name of Lender: \_\_\_\_\_

Loan Amount: \_\_\_\_\_ Loan Term (Years): \_\_\_\_\_

Amount Injected Into the Project by Business/Partners/Owners: \_\_\_\_\_

Other Funding Source(s) and Amount(s): \_\_\_\_\_

---

**C. PROJECT LOCATION:**

- |  |   |                             |
|--|---|-----------------------------|
| Within the Crete City Limits?              | <input type="checkbox"/> Yes            | <input type="checkbox"/> No |
| Within the Crete Two-Mile Jurisdiction?    | <input type="checkbox"/> Yes            | <input type="checkbox"/> No |
| Land Owned by the City of Crete?           | <input checked="" type="checkbox"/> Yes | <input type="checkbox"/> No |
| Not Located in Crete but for area benefit? | <input type="checkbox"/> Yes            | <input type="checkbox"/> No |

If Not in City Jurisdiction, please explain local benefit: \_\_\_\_\_

---

**D. ATTACHMENTS: - Please Include the Attachments that Apply to Your Entity**

**Please Note:** The Information provided pursuant to this Section Will be Deemed Confidential and will not be Available for Public Disclosure.

- Brief Description of the Business
- Resumes of all Owners/Co-Owners/Directors/Partners/Stockholders
- For Existing Businesses – Three (3) Yearly Financial Statements
- For Existing Businesses – Current Financial Statements (Less Than Sixty (60) Days Old)
- For Start-Up Businesses – Current Business Plan
- For Start-Up Businesses – Three Year Projections
- For Existing Businesses - List of Current Obligations (Include Company Names and Amounts)
- Tax Returns – Previous Three (3) Years – Personal Tax Returns May be Required for Proprietorship
- Letter from Lending Institution if applicable
- If a Corporation, LLC or Other Legal Entity - Copy of Organizational Documents (Articles, ByLaws)
- Please Note that Other Financial Documents May Be Required

**E. APPLICANT SIGNATURE:**

I certify that the information contained in this application and all attachments are correct to the best of my knowledge. By signing below, I authorize the City of Crete or their contracted representative to check my credit and the credit of all who are listed within this application. I understand that I must update my credit information if my financial situation changes.

  
\_\_\_\_\_  
Applicant's Signature

January 16, 2013  
\_\_\_\_\_  
Date

# United States Citizenship Attestation Form

For the purpose of complying with Neb. Rev. Stat. §§ 4-108 through 4-114, I attest as follows:

<input checked="" type="checkbox"/> I am a citizen of the United States.
— OR —
<input type="checkbox"/> I am a qualified alien under the federal Immigration and Nationality Act, my immigration status and alien number are as follows: _____, and I agree to provide a copy of my USCIS documentation upon request.

I hereby attest that my response and the information provided on this form and any related application for public benefits are true, complete, and accurate and I understand that this information may be used to verify my lawful presence in the United States.

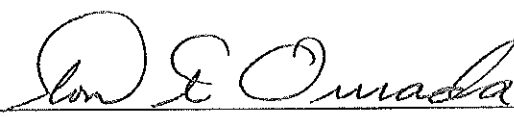
PRINT NAME	Tom Ourada <i>F.</i> _____ (first, middle, last)
SIGNATURE	 _____
DATE	January 16, 2013 _____

1/19/2010

### Estimate cost per Dugout

8.5 yds Concrete for footing \$1,000.00  
Laobr \$1,800.00

Concerte Block \$760.00  
Mortor Mix \$90.00  
Laobr \$2,700.00

### Building Materials

2- 30' x 12" LVL beams \$360.00  
26 - 2"x6"x8' CCA \$115.00  
10 PP 10" (tin) \$320.00  
2"x6"x16 (facia) \$20.00  
3 apron piece \$18.00  
(2 -10" )trim for metel roof \$30.00  
Miscellaneous nails screws \$50.00  
Aluminum benching (30ft) \$1,900.00  
6Ft chain link fence w/post ( front protection) \$700.00  
Labor to construct \$1,200.00

Total price for single dug out \$11,063.00

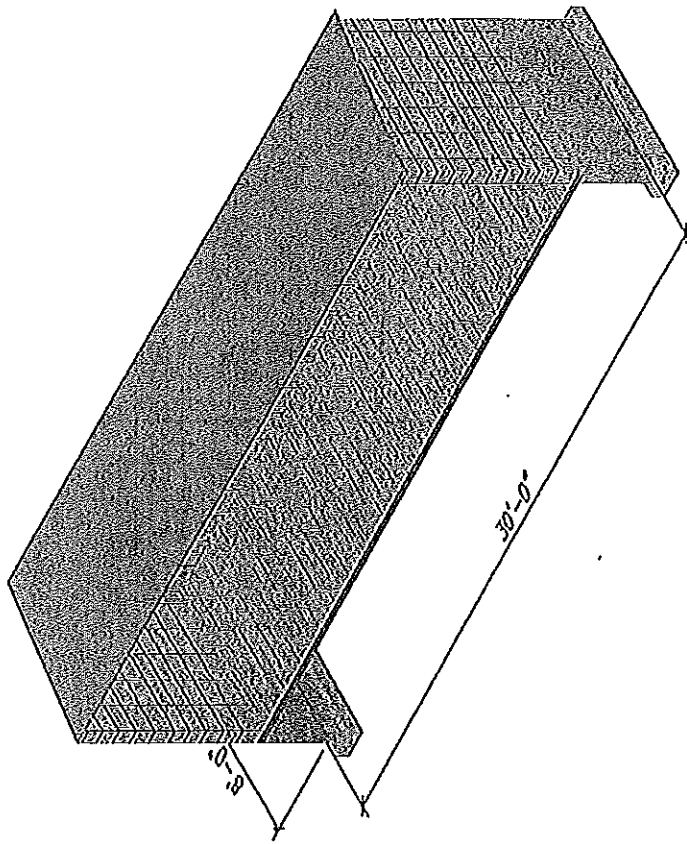

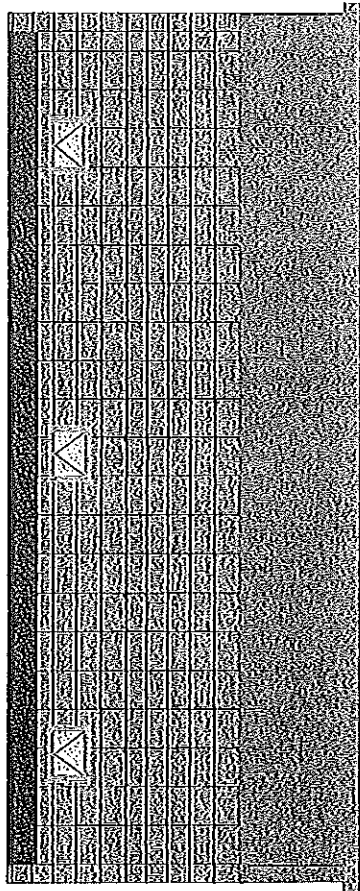

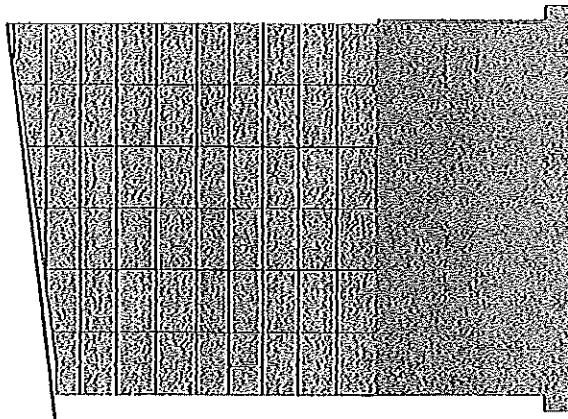

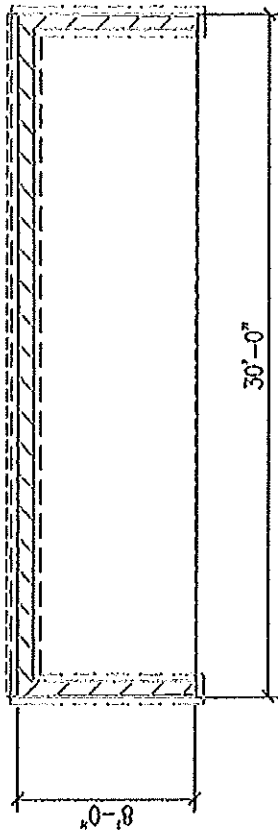

Economic Development Program  
Recommendation Form

Applicant: City of Crete

Public Hearing Date: 1/23/13 June 1/30/13

Criteria Met:

Allowed Activity: Rehab (#1-15)

Eligible Entity: City (#1-11)

Entity: Existing (startup, buyout, existing)

Request:

Application Amount: \$11,063- (grant or income guarantee)

Term: Lump (lump sum or number of years)

Matching Funds: \$11,063- Program: Legion providing

Economic Impact: \_\_\_\_\_ (dollars) and/or \_\_\_\_\_ (jobs) and/or  
City Image, Tournament (other value)

Recommendation:

Recommend funding \$ 11,063- Recruitment

Recommend partially funding \$ \_\_\_\_\_

Do not recommend funding

- Expenditure Category:
- Infrastructure/Real Estate Purchase/Development
  - Promotion/Tourism
  - Business/Professional Recruitment & Retention

Council Meeting date: \_\_\_\_\_

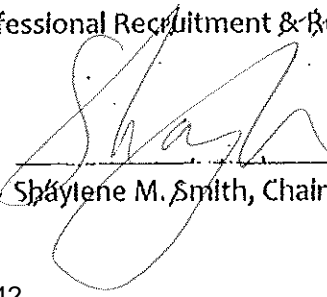
  
Shaylene M. Smith, Chair

**CITY OF CRETE – ECONOMIC DEVELOPMENT  
APPLICATION FOR FUNDS**

223 W 13<sup>th</sup> St – Crete NE 68333  
402-826-2566

Please Answer Each Question (If Question Does Not Apply – Mark N/A). Please Type or Print Clearly.

**Please Note:** The Information Contained in this portion of the document is Public Information and will **NOT** be Considered Confidential.

**A. APPLICANT INFORMATION**

Name of Entity Applying for Assistance: ISIS THEATRE

Business Address: 139 W 13TH STREET CRETE NE 68333  
(City) (State) (Zip Code)

Contact Person: THOMAS REEVES Telephone Number: 402-484-7702

Fax Number: NA Email Address: treeves@amerityas.com

Federal Tax ID Number: 47-0732410

Type of Entity:  Start-Up  Buyout  Existing

If Existing, Number of Years in Business in Crete: 86

**Business Classification: (Please Choose One)**

- Retail  Manufacturing  Research & Development  
 Headquarter  Telecommunications  Tourism  
 Warehouse/Distribution  Government  Other

**Business Type: (Please Choose One)**

- Proprietorship  Corporation  Partnership  
 LLC  Governmental Entity  Other

Does the Company have a Parent or Subsidiaries?  Yes  No

If Yes, Please List Name: NA

Address: NA  
(City) (State) (Zip Code)

Ownership Identification: Please List all Officers, Directors, Partners, Owners, Co-owners and Stockholders.

Full Name	Title	Ownership Percentage
THOMAS ROLAND REEVES	OWNER-MANAGER	100%

Which type of assistance is the entity applying for?

Grant       Loan Guarantee If so, Lender? \_\_\_\_\_       Other

Explain: IMPLEMENT NEW TECHNOLOGY REQUIRED BY INDUSTRY

What is the general purpose of the request (must be an allowed LB840/Economic Dev. Plan Project)?

New Development     New Business Startup       Building Renovation       Public Works

Professional/Employee Recruitment       Promotion/Tourism       Job Training

Technology     Working Capital       Low - Moderate Income Housing       Plan Management

Does the business qualify to receive any incentives from the State of Nebraska?  Yes  No  DK

Has the business applied for any incentives from the State of Nebraska?  Yes  No

If yes, please explain: NA

Employee Information: (FTE = Full-Time Equivalent = 2,080 Hours/Per Year)

Number of Existing Full-Time Equivalent Employees: 2,375 (10 PART TIME EMPLOYEES MANG)

Number of Full-Time Equivalent Positions to Be Created: .5 (ESTIMATE OF 2 ADDITIONAL PT EES)

Will all of the Full-Time Equivalent Positions be Physically Located within the City of Crete, their Two-Mile Extraterritorial Jurisdiction or on Land Held in the Name of the City of Crete?  Yes  No

If no, please explain: NA

Does the Company Employ Any Seasonal Employees?  Yes  No

If Yes, How Many: NA  
(Seasonal employees must work for at lease three continuous months and the position must reoccur annually)

**B. PROJECT INFORMATION:**

Please provide a Brief Project Description:

INSTALLATION OF NEW TECHNOLOGY NEEDED TO STAY IN BUSINESS. FILM INDUSTRY IS CHANGING TO ALL DIGITAL PRINTS FROM 35MM FILM. THIS REQUIRES DIGITAL PROJECTOR, SERVER, SOUND EQUIPMENT AND SPEAKERS, AND SCREEN.

Use of Funds	Total Project Cost	Econ Dev Funds Requested
Land or Facility Acquisition	\$	\$
Facility Renovation	\$ 5,000 EST	\$ 2500
New Facility Construction	\$	\$
Machinery / Equipment Acquisition	\$ 79,573.86	\$ 39,786.93
Business / Employee Recruitment Activities	\$	\$
Technology Costs	\$	\$
Small Business Development	\$	\$
Working Capital (Includes Inventory)	\$	\$
Job Training	\$ 1,000 EST	\$ 500
Other	\$	\$
Total Project Cost	\$ 85,573.86	
	Total LB840 Funds Requested:	\$ 42,786.93

**C. FUNDING SOURCES AND EQUITY INJECTION:**

If Borrowing, Name of Lender: NA

Loan Amount: NA Loan Term (Years): NA

Amount Injected Into the Project by Business/Partners/Owners: NA

Other Funding Source(s) and Amount(s): DONATIONS (30,000 TO DATE) PERSONAL LINE OF CREDIT

**C. PROJECT LOCATION:**

- Within the Crete City Limits?  Yes  No  
Within the Crete Two-Mile Jurisdiction?  Yes  No  
Land Owned by the City of Crete?  Yes  No  
Not Located in Crete but for area benefit?  Yes  No

If Not in City Jurisdiction, please explain local benefit: NA - BUILDING LOCATED  
IN DOWNTOWN CRETE

**D. ATTACHMENTS: - Please Include the Attachments that Apply to Your Entity**

**Please Note:** The Information provided pursuant to this Section **Will** be Deemed Confidential and will not be Available for Public Disclosure.

- Brief Description of the Business
- Resumes of all Owners/Co-Owners/Directors/Partners/Stockholders
- For Existing Businesses – Three (3) Yearly Financial Statements
- For Existing Businesses – Current Financial Statements (Less Than Sixty (60) Days Old)
- For Start-Up Businesses – Current Business Plan
- For Start-Up Businesses – Three Year Projections
- For Existing Businesses - List of Current Obligations (Include Company Names and Amounts)
- Tax Returns – Previous Three (3) Years – Personal Tax Returns May be Required for Proprietorship
- Letter from Lending Institution if applicable
- If a Corporation, LLC or Other Legal Entity - Copy of Organizational Documents (Articles, ByLaws)
- Please Note that Other Financial Documents May Be Required

**E. APPLICANT SIGNATURE:**

I certify that the information contained in this application and all attachments are correct to the best of my knowledge. By signing below, I authorize the City of Crete or their contracted representative to check my credit and the credit of all who are listed within this application. I understand that I must update my credit information if my financial situation changes.

*Mark L. ...*  
Applicant's Signature

1/19/2013  
Date

Economic Development Program  
Recommendation Form

Applicant: Isis Theater

Public Hearing Date: 1/23/13 and 1/30/13

Criteria Met:

- Allowed Activity: Renovation (#1-15)
- Eligible Entity: Service Business (#1-11)
- Entity: Existing (startup, buyout, existing)

Request:

- Application Amount: \$ 42,786.93 (grant or income guarantee)
- Term: Lump (lump sum or number of years)
- Matching Funds: \$ 42,786.93 Program: Community Fundraising
- Economic Impact: \_\_\_\_\_ (dollars) and/or 2-4 PT (jobs) and/or  
Keeps local entertainment (other value)

Recommendation:

- Recommend funding \$ 43,000.00 dollars local Contingent on verifying
- Recommend partially funding \$ \_\_\_\_\_ Balance raised
- Do not recommend funding before payment

- Expenditure Category:
- Infrastructure/Real Estate Purchase/Development
  - Promotion/Tourism
  - Business/Professional Recruitment & Retention

Council Meeting date: \_\_\_\_\_

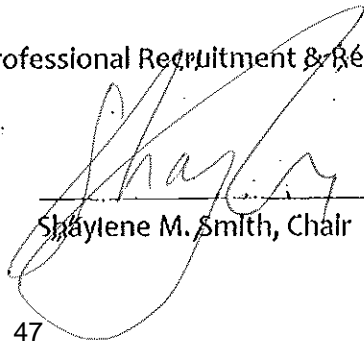
  
Shaylene M. Smith, Chair

**CITY OF CRETE – ECONOMIC DEVELOPMENT**  
**APPLICATION FOR FUNDS**  
223 W 13<sup>th</sup> St – Crete NE 68333  
402-826-2566

Please Answer Each Question (If Question Does Not Apply – Mark N/A). Please Type or Print Clearly.

**Please Note:** The Information Contained in this portion of the document is Public Information and will **NOT** be Considered Confidential.

**A. APPLICANT INFORMATION:**

Name of Entity Applying for Assistance: Tutti Frutti

Business Address: 1238 Main Ave Crete NE 68333  
(City) (State) (Zip Code)

Contact Person: Adelina Baires Telephone Number: 402-418-2623

Fax Number: N/A Email Address: Kenny.baires@hotmail.com

Federal Tax ID Number: \_\_\_\_\_

Type of Entity:       Start-Up       Buyout       Existing

If Existing, Number of Years in Business in Crete: 3 years

**Business Classification: (Please Choose One)**

- |   |   |   |
|---|---|---|
| <input checked="" type="checkbox"/> Retail      | <input type="checkbox"/> Manufacturing      | <input type="checkbox"/> Research & Development |
| <input type="checkbox"/> Headquarter            | <input type="checkbox"/> Telecommunications | <input type="checkbox"/> Tourism                |
| <input type="checkbox"/> Warehouse/Distribution | <input type="checkbox"/> Government         | <input type="checkbox"/> Other                  |

**Business Type: (Please Choose One)**

- |   |  |                                      |
|---|--|--------------------------------------|
| <input type="checkbox"/> Proprietorship | <input type="checkbox"/> Corporation         | <input type="checkbox"/> Partnership |
| <input type="checkbox"/> LLC            | <input type="checkbox"/> Governmental Entity | <input type="checkbox"/> Other       |

Does the Company have a Parent or Subsidiaries?     Yes     No

If Yes, Please List Name: N/A

Address: N/A  
(City) (State) (Zip Code)

Ownership Identification: Please List all Officers, Directors, Partners, Owners, Co-owners and Stockholders.

Full Name	Title	Ownership Percentage
Ajelina Baires	proposed owner	100%

Which type of assistance is the entity applying for?

Grant       Loan Guarantee If so, Lender? \_\_\_\_\_       Other

Explain: Requesting Funds to help with purchase.

What is the general purpose of the request (must be an allowed LB840/Economic Dev. Plan Project)?

New Development     New Business Startup       Building Renovation       Public Works  
 Professional/Employee Recruitment       Promotion/Tourism       Job Training  
 Technology       Working Capital       Low - Moderate Income Housing       Plan Management

Does the business qualify to receive any incentives from the State of Nebraska?  Yes  No  DK

Has the business applied for any incentives from the State of Nebraska?  Yes  No

If yes, please explain: \_\_\_\_\_

Employee Information: (FTE = Full-Time Equivalent = 2,080 Hours/Per Year)

Number of Existing Full-Time Equivalent Employees: 2 morning shift / 2 evening shift

Number of Full-Time Equivalent Positions to Be Created: 5 - five

Will all of the Full-Time Equivalent Positions be Physically Located within the City of Crete, their Two-Mile Extraterritorial Jurisdiction or on Land Held in the Name of the City of Crete?  Yes  No

If no, please explain: N/A

Does the Company Employ Any Seasonal Employees?  Yes  No

If Yes, How Many: 5 - five  
(Seasonal employees must work for at lease three continuous months and the position must reoccur annually)

**B. PROJECT INFORMATION:**

Please provide a Brief Project Description:

Please see attached resume  
sheet.

Use of Funds	Total Project Cost	Econ Dev Funds Requested
Land or Facility Acquisition	\$	\$
Facility Renovation	\$	\$
New Facility Construction	\$	\$
Machinery / Equipment Acquisition	\$ 40,000. <sup>00</sup>	\$ 20,000. <sup>00</sup>
Business / Employee Recruitment Activities	\$	\$
Technology Costs	\$ 5,000. <sup>00</sup>	\$ 2,500. <sup>00</sup>
Small Business Development	\$	\$
Working Capital (Includes Inventory)	\$ 5,000. <sup>00</sup>	\$ 2,500. <sup>00</sup>
Job Training	\$	\$
Other	\$	\$
Total Project Cost	\$	\$
	Total LB840 Funds Requested:	\$ 25,000. <sup>00</sup>

**C. FUNDING SOURCES AND EQUITY INJECTION:**

If Borrowing, Name of Lender: Pinnacle Bank - economic Development - loan

Loan Amount: \$ 10,000.<sup>00</sup> Loan Term (Years): \_\_\_\_\_

Amount Injected Into the Project by Business/Partners/Owners: \$ 5,000.<sup>00</sup>

Other Funding Source(s) and Amount(s): Seller will finance \$10,000.-

**C. PROJECT LOCATION:**

- Within the Crete City Limits?  Yes  No
- Within the Crete Two-Mile Jurisdiction?  Yes  No
- Land Owned by the City of Crete?  Yes  No
- Not Located in Crete but for area benefit?  Yes  No

If Not in City Jurisdiction, please explain local benefit: N/A

**D. ATTACHMENTS:** - Please Include the Attachments that Apply to Your Entity

**Please Note:** The Information provided pursuant to this Section **Will** be Deemed Confidential and will not be Available for Public Disclosure.

- Brief Description of the Business
- Resumes of all Owners/Co-Owners/Directors/Partners/Stockholders
- For Existing Businesses – Three (3) Yearly Financial Statements
- For Existing Businesses – Current Financial Statements (Less Than Sixty (60) Days Old)
- For Start-Up Businesses – Current Business Plan
- For Start-Up Businesses – Three Year Projections
- For Existing Businesses - List of Current Obligations (Include Company Names and Amounts)
- Tax Returns – Previous Three (3) Years – Personal Tax Returns May be Required for Proprietorship
- Letter from Lending Institution if applicable
- If a Corporation, LLC or Other Legal Entity - Copy of Organizational Documents (Articles, ByLaws)
- Please Note that Other Financial Documents May Be Required

**E. APPLICANT SIGNATURE:**

I certify that the information contained in this application and all attachments are correct to the best of my knowledge. By signing below, I authorize the City of Crete or their contracted representative to check my credit and the credit of all who are listed within this application. I understand that I must update my credit information if my financial situation changes.

Cedellina Daines  
Applicant's Signature

12-26-12  
Date

# United States Citizenship Attestation Form

For the purpose of complying with Neb. Rev. Stat. §§ 4-108 through 4-114, I attest as follows:

<input type="checkbox"/> I am a citizen of the United States.
— OR —
<input checked="" type="checkbox"/> I am a qualified alien under the federal Immigration and Nationality Act, my immigration status and alien number are as follows: <u>WAC 05224 90045</u> , and I agree to provide a copy of my USCIS documentation upon request.

I hereby attest that my response and the information provided on this form and any related application for public benefits are true, complete, and accurate and I understand that this information may be used to verify my lawful presence in the United States.

PRINT NAME	<u>Adelina Baites</u> (first, middle, last)
SIGNATURE	<u>Adelina Baites</u>
DATE	<u>12-26-12</u>

### **Brief Project Description**

My name is Adelina Baires and I have lived in the Crete for almost Four years now with my two sons. My son Kenny R. Baires will be the manager of Tutti Frutti. This will continue until he turns nineteen where he will then become part owner of the restaurant.

Tutti Frutti is a contemporary café with a big city feel. It will be a great asset to the Crete Community, which will be located in downtown. This is also important because it will be the only one in the downtown area. As a member of the community, Tutti Frutti has been seen as a part of the community for me and others I have spoken to.

Tutti Frutti has an extensive menu composed of health natural smoothies, natural fresh juices, and a frozen dipping ice cream bar which is the old fashion way of serving ice-cream. The old fashion dipping ice-cream is not offered anywhere else in Crete. They also serve Panini sandwiches, soups, and salads. It will also include a variety of Mexican and Mexican-American entrées with its own menu set. I will also receiving help from my significant other and two sons. My significant other has twenty nine years of restaurant experience which will be a benefit to Tutti Frutti.

It also provides for seasonal and part-time work for students as well as a part-time hang out for the student body in the community. Also Tutti Frutti's logo is "eat smart", which promotes healthy eating habits and tries to appeal to everyone. Tutti Frutti also serves as a meeting place for community based organizations and family events.

# Kenny R. Baires

1846 Main Ave  
Crete, Nebraska 68333  
402-418-2623  
GPA 3.13

## HONORS & AWARDS

Honor Roll.....	9-12
Music Letter.....	9-12
Academic Letter.....	11-12
Nebraska Music Educators Association; All-State Band.....	11-12
Conference Honor Band.....	9-11
University of Nebraska at Kearney Honor Band.....	11-12
Doane College Honor Band.....	9-12
Lincoln Elks Lodge No.80; Elks Youth Program- Instrumental Music Award.....	11
Latino Leaders (Latino Honors Program).....	11-12
Gallery of Stars-Omaha Latino Summit.....	11
Homecoming King.....	12

## EXTRA CURRICULAR ACTIVITIES

Band.....	6-12
• Pep Band.....	7-12
• Marching Band.....	9-12
• Concert Band.....	6-12
• Jazz Band.....	9-12
Student Council (Band Representative).....	12
Prizm Club (Diversity Club).....	11-12
F.B.L.A (Future Business Leaders of America).....	11-12
Senior PAL (Mentor Elementary Student).....	12

## SPORTS

Football.....	10-12
• Letter...10-12	
Track.....	10-12

## VOLUNTEERISM/COMMUNITY SERVICE

Community Service-F.B.L.A Breakfast with Santa, elementary school.....	11-12
Crete Cares (food donation service; pack & delivery).....	12
(LDS)Church Project-Paint homes for the homeless.....	9-10
Nursing Homes-entertainment with a band.....	9-10
Saving Isis (Fund raising activity for local theatre) .....	12
Community Service Cleaning; Storm Lake, Iowa.....	11
(LDS) church volunteer cleaning; Lincoln, NE.....	12

## WORK EXPERIENCE

Detasseling.....	9-11–Approximately 120 hours per summer
Roca Berry Farm.....	11–Approximately 80 hours per summer

## **Adelina Baires**

1846 Main Ave  
Crete, Nebraska 68333  
402-418-1905

### **RECENT WORK EXPERIENCE**

*Liberty Foods* (chef in the Crete Farmland Foods, Inc. cafeteria) -one year

*V.V.S Inc.* (chef in the Crete Farmland Foods, Inc. cafeteria) -one year

*Farmland Foods, Inc.* (currently assembly line worker) -two years

### **EDUCATION**

Received a 9<sup>th</sup> grade Education- San Salvador, El Salvador

Graduated-*Marinello Beautiful School*; Los Angeles, California

Six months course-*Cosmetology* license

Six months of *G.E.D courses*-Crete, NE

*Certificate of Merit* for the completed four courses in Pastry-Buford, Georgia

- Variety of cake pastry
- Decoration courses for design and arrangement for cakes

## Business Lease With Option To Purchase

This Lease Agreement (this "Lease") is dated December 15, 2012, by and between Tutti Frutti, LLC ("Landlord"), and Adelina Baires and Kenny Robert Baires (acknowledged by the parties to be a minor with a date of birth 10-07-1994), ("Tenants"). It is the desire of the parties for the Tenants to purchase the Company of Tutti Frutti, LLC, A Nebraska Limited Liability Company, but the Tenants are in need of additional time to investigate financing options. Therefore, the parties agree as follows:

**PREMISES.** Landlord, in consideration of the payment of \$5,000 for the Option to Purchase, to be paid at the time of signing of this Lease, and in further consideration of the lease payments provided in this Lease, leases to Tenant the business assets and subleases the property located at 1238 Main Street, Crete, Nebraska (the "Premises").

**TERM.** The lease term will begin on December 15, 2012, and will terminate on March 15, 2013, or upon closing of the sale of the Company, whichever first occurs.

**DEPOSIT AMOUNT.** No Deposit shall be required as the Landlord shall continue to assist with and have access to the business for the duration of the lease.

**LEASE PAYMENTS.** Business assets lease payments of \$750 per month commencing on January 1, 2013, shall be made to the Landlord at 1238 Main Ave., Crete, NE 68333, which address may be changed from time to time by the Landlord. In the event the Tenant exercises the option to purchase the Landlord agrees to credit the amount of \$750.00 from each paid monthly lease payment towards the purchase price of the business assets.

The parties acknowledge that the Seller is in possession of the premises of 1238 Main Ave. as a result of a lease for the same. As additional consideration for the lease of the business assets, the Tenants shall pay the building rent due directly to Terri White in the sum due on or before the first of each month of this lease. In the event of purchase the Tenant is not given any credit therefor. The Tenant is free to negotiate a separate lease directly with the real estate landlord but in the event a new lease is not negotiated, the Tenant shall pay the Landlord rental balance for said real estate and shall be a sublessee subject to all of the terms of conditions of the Landlord's lease of the premises so long as the Tenant is in possession of the business assets, which lease is attached hereto and incorporated herein by reference.

**POSSESSION.** Tenant shall be entitled to possession of the business assets on December 15, 2012, for purposes of readying the business to reopen by January 2, 2012, and shall yield possession to Landlord on the last day of the term of this Lease, unless successful in purchasing the business and obtaining an assignment of the real estate lease or a new written lease for the premises prior to the conclusion hereof or unless agreed by both parties in writing. At the expiration of the term, Tenant shall peaceably yield up the Premises and business assets to Landlord in as good a condition as when delivered to Tenant, ordinary wear and tear excepted.

**USE OF PREMISES.** Tenant may use the Premises only for operation of the business known as Tutti Frutti in its current location. The Premises may be used for any other purpose only with the prior written consent of Landlord. Tenant shall manage the business affairs of Tutti Frutti during the term of this lease as if they were the owner and shall keep any earned profit after payment of all expense subject to the Landlord's written confirmation of profit at least bi-weekly before the Tenant is allowed to draw the same. Tenant may make reasonable changes to the menu and sale practices of Tutti Frutti so long as the business and assets may be returned to the Landlord in the same condition at the conclusion of this Lease as it was at the commencement.

**BUSINESS EXPECTATION.** Tenant is expected to maintain the business hours, condition and reputation in as good a condition as it is at the commencement of this lease and they shall notify Landlord of any unanticipated absence from the Premises not later than the first day of the absence and allow the Landlord to immediately terminate this Lease and Option and resume possession of the Premises for purposes of resuming business operations if deemed necessary at the option of the Landlord. extended absence.

**ASSETS.** The following business assets will be provided: Attached As Exhibit "A"

**INSURANCE: PROPERTY.** Landlord and Tenant shall each maintain appropriate insurance for their respective interests in the business and property located on the Premises. Landlord shall be named as an additional insured in such policies. Tenant shall deliver appropriate evidence to Landlord as proof that adequate insurance is in force issued by companies reasonably satisfactory to Landlord. Landlord shall receive advance written notice from the insurer prior to any termination of such insurance policies. Tenant shall also maintain any other insurance which Landlord may reasonably require for the protection of Landlord's interest in the Premises. Tenant is responsible for maintaining casualty insurance on its own property.

**INSURANCE: LIABILITY.** Tenant shall maintain liability insurance on the Premises in a total aggregate sum of at least \$1,000,000.00. Tenant shall deliver appropriate evidence to Landlord as proof that adequate insurance is in force issued by companies reasonably satisfactory to Landlord. Landlord shall receive advance written notice from the insurer prior to any termination of such insurance policies.

**MAINTENANCE.** Tenant shall have the responsibility to maintain the Premises and all business assets in good repair at all times during the term of this Lease. Any asset requiring repair shall be fixed in a good, commercial and timely manner at the Tenant's cost.

**UTILITIES AND SERVICES.** Tenant shall be responsible for all utilities and services incurred in connection with the Premises from and after December 15, 2012. The utilities shall remain in the Landlord's name through closing on the anticipated purchase by the Tenant shall reimburse the Landlord within 5 days of receipt of the utility bill(s) for their term of possession.

**COMPANY IN IT'S ENTIRETY.** Should the Buyer exercise the option to purchase Tutti Frutti, LLC, as set forth herein, the Buyer acknowledges that they are acquiring the full Limited Liability Company including all of its accounts, inventory, assets and liabilities.

**PAYMENT WARRANTY.** The current members of Tutti Frutti, LLC, hereby warrant to the Tenants that all operating expenses, debts, sales tax, employment obligations, personal property taxes and other liabilities of the business due or incurred on or before December 14, 2012, excluding the cost of any inventory transferred to the Tenant on December 15, 2012, shall be paid for in full prior to the anticipated closing should the Tenant exercise the option granted to them hereunder.

**EMINENT DOMAIN.** If the whole or any part of the leased premises shall be taken by eminent domain, the term of this Lease shall terminate from the date title vests in the governmental authority. Tenant shall have no claim against Landlord for the value of any unexpired term of this Lease. No part of any award shall belong to Tenant.

**DEFAULTS.** Tenant shall be in default of this Lease if Tenant fails to fulfill any lease obligation or term by which Tenant is bound. Subject to any governing provisions of law to the contrary, if Tenant fails to cure any financial obligation within 5 days (or any other obligation within 10 days) after written notice of such default is provided by Landlord to Tenant, Landlord may take possession of the Premises without further notice (to the extent permitted by law), and without prejudicing Landlord's rights to damages. In the alternative, Landlord may elect to cure any default and the cost of such action shall be added to Tenant's financial obligations under this Lease. Tenant shall pay all costs, damages, and expenses (including reasonable attorney fees and expenses) suffered by Landlord by reason of Tenant's defaults. All sums of money or charges required to be paid by Tenant under this Lease shall be additional rent, whether or not such sums or charges are designated as "additional rent". The rights provided by this paragraph are cumulative in nature and are in addition to any other rights afforded by law.

**LATE PAYMENTS.** For any payment that is not paid within 5 days after its due date, Tenant shall pay a late fee of \$25.00.

**CUMULATIVE RIGHTS.** The rights of the parties under this Lease are cumulative, and shall not be construed as exclusive unless otherwise required by law.

**REMODELING OR STRUCTURAL IMPROVEMENTS.** Tenant shall not complete any construction or remodeling unless given prior written permission by the Landlord. If such permission is granted all remodeling shall be at Tenant's expense and the Tenant shall insure that no mechanic's or construction lien may be placed on the premises.

**ACCESS BY LANDLORD TO PREMISES.** Subject to Tenant's consent (which shall not be unreasonably withheld), Landlord shall have the right to enter the Premises to make inspections or provide necessary services. However, Landlord does not assume any liability for the care or supervision of the Premises or business assets. As provided by

law, in the case of an emergency, Landlord may enter the Premises without Tenant's consent.

**INDEMNITY REGARDING USE OF PREMISES.** To the extent permitted by law, Tenant agrees to indemnify, hold harmless, and defend Landlord from and against any and all losses, claims, liabilities, and expenses, including reasonable attorney fees, if any, which Landlord may suffer or incur in connection with Tenant's possession, use or misuse of the Premises, except Landlord's act or negligence.

**COMPLIANCE WITH REGULATIONS.** Tenant shall promptly comply with all laws, ordinances, requirements and regulations of the federal, state, county, municipal and other authorities, and the insurance underwriters. Because the business operates as a restaurant, the Buyer acknowledges that they will hold all necessary food handler permits and any other required permissions to continue to operate the business. However, Tenant shall not by this provision be required to make alterations to the exterior of the building or alterations of a structural nature.

**RELATIONSHIP OF PARTIES.** Landlord and Tenant shall not be considered or deemed to be joint venturers or partners and neither shall have the power to bind or obligate the other except as set forth herein.

**PURCHASE.** Tenant shall, at any time during the term of this lease, have the option to purchase the Company of Tutti Frutti, LLC, A Nebraska Limited Liability Company, including all of its accounts, assets, interests and going business described herein, for the additional purchase price of \$45,000.00, reduced by any rental payments made hereunder, provided that the Tenant timely executes a purchase agreement and pays at least \$35,000 of the purchase price prior to the expiration of the lease as part of the closing. The Landlord will agree that should the Buyer not be in a position to pay the remaining \$10,000 due prior to the expiration of the lease, the Landlord/Seller will agree to personally carry not more than \$10,000 provided the Buyer/Tenant executes a promise to pay the same with interest at the rate of 6% per annum in equal monthly installments for not more than twenty-four months.

**NOTICE REQUIRED TO EXERCISE OPTION.** To exercise the Option to Purchase, the Tenant must deliver to the Landlord, a written notice of Tenant's intent to purchase. In addition, the written notice must specify a valid closing date and set forth that portion of the purchase price which the Tenants are able to pay at closing and that portion which the Landlord would be asked to carry for an additional term of not more than two (2) years at 6% per annum. The closing date must occur before the original expiration date of the Lease Agreement.

**EXCLUSIVITY OF OPTION.** This Option to Purchase Agreement is exclusive and non-assignable and exists solely for the benefit of the named parties above. Should Tenant attempt to assign, convey, delegate, or transfer this option to purchase without the Landlord's express written permission, any such attempt shall be deemed null and void.

**CLOSING AND SETTLEMENT.** Tenant agrees that any financing-related closing costs, including any points, fees, and other charges required by a third-party lender, shall be the sole responsibility of Tenant. The Landlord shall pay for the legal fees incurred for preparation of this Lease and all legal documents necessary to close the sale.

**DISCLAIMER.** THE PARTIES ACKNOWLEDGE THAT IT IS IMPOSSIBLE TO PREDICT THE AVAILABILITY OF OBTAINING FINANCING TOWARDS THE PURCHASE OF THIS COMPANY. THE PARTIES FURTHER AGREE THAT THIS OPTION TO PURCHASE AGREEMENT IS NOT ENTERED INTO IN RELIANCE UPON ANY REPRESENTATION OR WARRANTY MADE BY EITHER PARTY EXCEPT AS PROVIDED HEREIN.

**REMEDIES UPON DEFAULT.** If Tenant defaults under the terms of this Lease Agreement or fails to exercise the Option to Purchase, then in addition to any other remedies available to Landlord at law or in equity, Landlord may terminate this Option to Purchase by giving written notice of the termination. If terminated, the Tenant shall lose entitlement to any refund of rent paid or option consideration paid. For this Option to Purchase Agreement to be enforceable and effective, the Tenant must comply with all terms and conditions of the Lease Agreement.

**RECORDING OF AGREEMENT.** Tenant shall not record this Option to Purchase Agreement on the Public Records of any public office without the express and written consent of Landlord. Tenant shall not record this Option to Purchase Agreement on the Public Records of any public office without the express and written consent of Landlord.

**ACKNOWLEDGMENTS.** The parties are executing this Option to Purchase Agreement voluntarily and without any duress or undue influence. The parties have carefully read this Lease and Option to Purchase Agreement and have asked any questions needed to understand its terms, consequences, and binding effect and fully understand them and have been given an executed copy.

**NOTICE.** Notices under this Lease shall not be deemed valid unless given or served in writing and forwarded by mail, postage prepaid, addressed as follows:

LANDLORD:  
Tutti Frutti, LLC  
1238 Main Street  
Crete, NE 68333

TENANT:  
Adelina Baires  
Kenney Robert Baires  
1848 Main Ave.  
Crete, NE 68333

Such addresses may be changed from time to time by either party by providing notice as set forth above. Notices mailed in accordance with the above provisions shall be deemed received on the third day after posting.

**GOVERNING LAW.** This Lease shall be construed in accordance with the laws of the State of Nebraska.

**ENTIRE AGREEMENT/AMENDMENT.** This Lease Agreement contains the entire agreement of the parties and there are no other promises, conditions, understandings or other agreements, whether oral or written, relating to the subject matter of this Lease. This Lease may be modified or amended in writing, if the writing is signed by the party obligated under the amendment.

**SEVERABILITY.** If any portion of this Lease shall be held to be invalid or unenforceable for any reason, the remaining provisions shall continue to be valid and enforceable. If a court finds that any provision of this Lease is invalid or unenforceable, but that by limiting such provision, it would become valid and enforceable, then such provision shall be deemed to be written, construed, and enforced as so limited.

**WAIVER.** The failure of either party to enforce any provisions of this Lease shall not be construed as a waiver or limitation of that party's right to subsequently enforce and compel strict compliance with every provision of this Lease. The failure of either party to enforce any provisions of this Lease shall not be construed as a waiver or limitation of that party's right to subsequently enforce and compel strict compliance with every provision of this Lease.

**BINDING EFFECT.** The provisions of this Lease shall be binding upon and inure to the benefit of both parties and their respective legal representatives, successors and assigns.

LANDLORD:  
Tutti Frutti, LLC

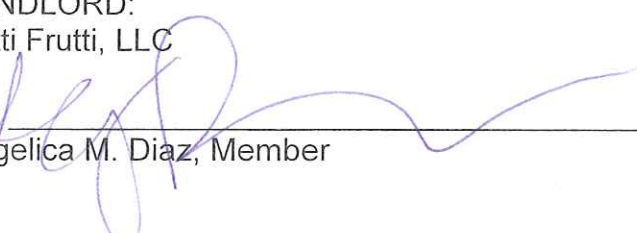
By:   
Angelica M. Diaz, Member

Date: 12-13-12

TENANT:

  
Adelina Baires

Date: 12-14-12

TENANT:

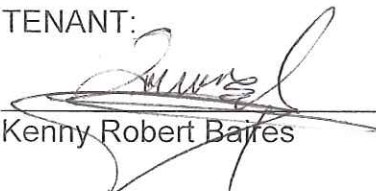
  
Kenny Robert Baires

Date: 12-14-12

Economic Development Program  
Recommendation Form

Applicant: Tutti Frutti - Baires Family

Public Hearing Date: 1/23/13 and 1/30/13

Criteria Met:

Allowed Activity: Equipment Purchase (#1-15)

Eligible Entity: Commercial Diner (#1-11)

Entity: Buyout (startup, buyout, existing)

Request:

Application Amount: \$25,000 (grant or income guarantee)

Term: Lump (lump sum or number of years)

Matching Funds: own money / seller financing Program: \_\_\_\_\_

Economic Impact: \_\_\_\_\_ (dollars) and/or 2.5 (jobs) and/or

Main Street Business (other value)

Recommendation:

Recommend funding \$ \_\_\_\_\_

Recommend partially funding \$ 12,500

10,000 Acquisition  
2,500 Technology

Do not recommend funding

Expenditure Category:

Infrastructure/Real Estate Purchase/Development

Promotion/Tourism

Business/Professional Recruitment & Retention

Council Meeting date: \_\_\_\_\_

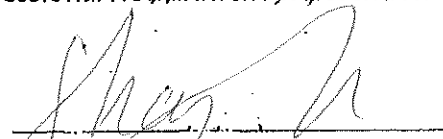
  
Shaylene M. Smith, Chair

Economic Development Board  
c/o Shaylene Smith, Chair  
PO Box 272  
Crete, NE 68333

# CITY OF CRETE

## Application for Funds

Please Answer Each Question (If Question Does Not Apply – Mark N/A). Please Type or Print Clearly.

Please Note: The Information Contained in this portion of the document is Public Information and will NOT be Considered Confidential.

### A. APPLICANT INFORMATION:

Name of Entity Applying for Assistance: Winterlude Committee / Crete Chamber

Business Address: 239 East 13<sup>th</sup> St., Crete NE 68333  
(City) (State) (Zip Code)

Contact Person: Deb Polacek Telephone Number: 402.826.2136

Fax Number: 402-826-2136 Email Address: cretechamber@neb.rr.com

Federal Tax ID Number: \_\_\_\_\_

Type of Entity:  Start-Up  Buyout  Existing

If Existing, Number of Years in Business in Crete: Winterlude (1)

Business Classification: (Please Choose One)

- |   |   |   |
|---|---|---|
| <input type="checkbox"/> Retail                 | <input type="checkbox"/> Manufacturing      | <input type="checkbox"/> Research & Development |
| <input type="checkbox"/> Headquarter            | <input type="checkbox"/> Telecommunications | <input type="checkbox"/> Tourism                |
| <input type="checkbox"/> Warehouse/Distribution | <input type="checkbox"/> Government         | <input checked="" type="checkbox"/> Other       |

Business Type: (Please Choose One)

- |   |  |  |
|---|--|--|
| <input type="checkbox"/> Proprietorship | <input type="checkbox"/> Corporation         | <input type="checkbox"/> Partnership                       |
| <input type="checkbox"/> LLC            | <input type="checkbox"/> Governmental Entity | <input checked="" type="checkbox"/> Other <u>Nonprofit</u> |

Does the Company have a Parent or Subsidiaries?  Yes  No

If Yes, Please List Name: \_\_\_\_\_

Address: \_\_\_\_\_  
(City) (State) (Zip Code)

Ownership Identification: Please List all Officers, Directors, Partners, Owners, Co-owners and Stockholders.

Full Name	Title	Ownership Percentage
Deb Polacek	Chamber Director	
Preston Meints	President Chamber	
See attached listing of Board Members.		

Which type of assistance is the entity applying for?

Grant       Loan Guarantee If so, Lender? \_\_\_\_\_       Other

Explain: \_\_\_\_\_

What is the general purpose of the request (must be an allowed LB840/Economic Dev. Plan Project)?

- New Development       New Business Startup       Building Renovation       Public Works  
 Professional/Employee Recruitment       Promotion/Tourism       Job Training  
 Technology       Working Capital       Low - Moderate Income Housing       Plan Management

? Does the business qualify to receive any incentives from the State of Nebraska?  Yes  No  DK

? Has the business applied for any incentives from the State of Nebraska?  Yes  No

If yes, please explain: \_\_\_\_\_

? Employee Information: (FTE = Full-Time Equivalent = 2,080 Hours/Per Year)

Number of Existing Full-Time Equivalent Employees: \_\_\_\_\_

Number of Full-Time Equivalent Positions to Be Created: \_\_\_\_\_

Will all of the Full-Time Equivalent Positions be Physically Located within the City of Crete, their Two-Mile Extraterritorial Jurisdiction or on Land Held in the Name of the City of Crete?  Yes  No

If no, please explain: \_\_\_\_\_

Does the Company Employ Any Seasonal Employees?  Yes  No

If Yes, How Many: 1 Part Time Position

(Seasonal employees must work for at least three continuous months and the position must reoccur annually)

**B. PROJECT INFORMATION:**

Please Provide a Brief Project Description:

Winterlude is a community wide celebration of the history, arts, music and food of Crete.  
 See attached Flier for listing of activities.

Use of Funds	Total Project Cost	EconDev Funds Requested
Land or Facility Acquisition	\$	\$
Facility Renovation	\$	\$
New Facility Construction	\$	\$
Machinery/Equipment Acquisition	\$	\$
Business/Employee Recruitment Activities	\$	\$
Technology Costs	\$	\$
Small Business Development	\$	\$
Working Capital (Includes Inventory)	\$	\$
Job Training	\$	\$
Other Promotional materials; posters, newspaper ads, radio, inserts	\$ 7000.00	\$ 3500.00
<b>Total Project Cost:</b>	\$	
	<b>Total LB840 Funds Requested:</b>	\$ 3500.00

**C. FUNDING SOURCES AND EQUITY INJECTION:**

If Borrowing, Name of Lender: N/A

Loan Amount: \_\_\_\_\_ Loan Term (Years): \_\_\_\_\_

Amount Injected Into the Project by Business/Partners/Owners: \_\_\_\_\_

Other Funding Source(s) and Amount(s): \_\_\_\_\_

**D. PROJECT LOCATION:**

- |  |   |                             |
|--|---|-----------------------------|
| Within the Crete City Limits?              | <input checked="" type="checkbox"/> Yes | <input type="checkbox"/> No |
| Within the Crete Two-Mile Jurisdiction?    | <input checked="" type="checkbox"/> Yes | <input type="checkbox"/> No |
| Land Owned by the City of Crete?           | <input checked="" type="checkbox"/> Yes | <input type="checkbox"/> No |
| Not Located in Crete but for area benefit? | <input type="checkbox"/> Yes            | <input type="checkbox"/> No |

If Not in City Jurisdiction, please explain local benefit: \_\_\_\_\_

**E. ATTACHMENTS: - Please Include the Attachments that Apply to Your Entity**

Please Note: The Information provided pursuant to this Section Will be Deemed Confidential and will not be Available for Public Disclosure.

- Brief Description of the Business
- Resumes of all Owners/Co-Owners/Directors/Partners/Stockholders
- For Existing Businesses – Three (3) Yearly Financial Statements
- For Existing Businesses – Current Financial Statements (Less Than Sixty (60) Days Old)
- For Start-Up Businesses – Current Business Plan
- For Start-Up Businesses – Three Year Projections
- For Existing Businesses - List of Current Obligations (Include Company Names and Amounts)
- Tax Returns – Previous Three (3) Years – Personal Tax Returns May be Required for Proprietorship
- Letter from Lending Institution if applicable
- If a Corporation, LLC or Other Legal Entity - Copy of Organizational Documents (Articles, ByLaws)
- Please Note that Other Financial Documents May Be Required

**F. APPLICANT SIGNATURE:**

I certify that the information contained in this application and all attachments are correct to the best of my knowledge. By signing below, I authorize the City of Crete or their contracted representative to check my credit and the credit of all who are listed within this application. I understand that I must update my credit information if my financial situation changes.

  
\_\_\_\_\_  
Applicant's Signature

1-17-13  
\_\_\_\_\_  
Date

City of Crete Economic Development Plan  
Application for Funds Attachment  
NE 331899 TIN 47-6006154

## United States Citizenship Attestation Form

For the purpose of complying with Neb. Rev. Stat. § 4-108 through 4-114, I attest as follows:

I am a citizen of the United States.

**-OR-**

I am a qualified alien under the federal Immigration and Nationality Act, my immigration status and alien number are as follows: \_\_\_\_\_, and I agree to provide a copy of my USCIS documentation upon request.

I hereby attest that my response and the information provided on this form and any related application for public benefits are true, complete, and accurate and I understand that this information may be used to verify my lawful presence in the United States.

PRINT NAME ARESTON MEINTS  
(first, middle, last)

SIGNATURE 

DATE 1-17-13

1st Annual Winterlude Festival			
November 30 - December 1, 2012			
as of January 10, 2013			
Received	Income	2012	
8/16/2012	Jr. Jaycees Money Order	212.94	
	Donations for Lights		
9/27/2012	Nestle Purina Petcare Co.	550.00	
	Horse & Carriage Ride Sponsor		
11/7/2012	Crete Community Foundation	1200.00	
	Lights for Living Christmas Tree		
12/18/2012	CAMC	700.00	
	Ice Sculpting & Facebook Sponsor		
12/18/2012	Wine & Cheese Deposit	512.00	
	Total Deposit from this Event		
1/8/2013	Pinnacle Bank	500.00	
	Misc. Donation		
	Saline Co. Tourism Grant	1000.00	Requested 1/3/2012
	Advertising Support		Will be paid 1/25/13 per Kerry @ Saline Co Clerk's Office
	LB 840 Grant Funds	?	Who's requesting these funds?
	Doane College	?	Marilea is checking with Dr. Carter
	Crete Chamber of Commerce	?	Board Meeting is 1/15/13
	<b>TOTAL RECEIPTS</b>	<b>4674.94</b>	
Paid	Income	2012	
11/27/2012	Not Forgotten Farms LLC	550.00	Ck#1004
	Horse & Carriage Ride Co.		
11/27/2012	Ginney Backs	350.00	Ck#1005
	Ice Sculpture Artist		
1/10/2013	Dennis Isernhagen	135.39	Ck#1006
	Sunday Soup Luncheon Exp's		
1/10/2013	Prime Country Winery LLC	326.00	Ck#1007
	Wine for Wine & Cheese Event		
1/10/2013	Printing Plus	1179.64	Ck#1008
	5,000 Winterlude Posters 11X17		
1/10/2013	Voice News	502.00	Ck#1009
	Adv. Costs for Ads & Inserts		
	Crete True Value	1022.64	
	Lights,Cords,Chair Rental for Tree Lighting Ceremony		
	Jody Vondra	279.98	
	Facebook Page Costs		
	Crete News	3998.21	
	Adv.-Display Ads, Inserts, Posters		
	<b>TOTAL EXPENSES</b>	<b>8343.86</b>	
	<b>NET INCOME</b>	<b>-3668.92</b>	

KUTT

297

Doane Owl

68

75

Thursday folder inserts

200.<sup>00</sup>

*Monthly*

*Tutti Frutti  
ATTN: snay*

CATEGORY	BUDGET AMOUNT	ACTUAL AMOUNT	DIFFERENCE
Sales Revenue	\$ 10,000		
Interest Income	0		
Investment Income	0		
Other Income	0		
<b>TOTAL INCOME</b>			
<b>EXPENSES</b>	<b>\$10,000.00</b>		
Accounting Services	50.00		
Advertising	50.00		
Bank Service Charges	7.00		
Credit Card Fees	275.00		
Delivery Charges	0		
Deposits for Utilities	0		
Estimated Taxes	750.00		
Health Insurance	0		
Hiring Costs	0		
Installation/Repair of Equipment	250.00		
Interest on Debt	0		
Inventory Purchases	\$800.00		
Legal Expenses	\$100.00		
Licenses/Permits	\$200.00		
Loan Payments	\$700.00		
Office Supplies	25.00		
Payroll	\$800.00		
Payroll Taxes	200.00		
Printing	0		
Professional Fees	0		
Rent/Lease Payments	750.00		
Retirement Contributions	0		
Subscriptions and Dues	0		
Utilities and Telephone	530.00		
Vehicle Expenses	0		
Other	0		
Other	0		
<b>TOTAL EXPENSES</b>	<b>\$5487.00</b>		
<b>TOTAL INCOME MINUS TOTAL EXPENSES</b>	<b>\$4513.00</b>		



# Crete Winterlude Festival

Nov. 30, Dec. 1-2

## Friday, Nov. 30

- 5:30 p.m. CRETE - IMAGES OF AMERICA COFFEE HOUR**  
A historical presentation by Janet Jeffries - Kava Korner, 445 E. 13th Street
- 7 p.m. COMMUNITY TREE LIGHTING & TREE OF LIGHTS CEREMONY**  
Celebrate Crete as the home of the first The First Living Christmas Tree - light the town and enjoy a Community Choir and Live Nativity. Honor or remember a loved one with a personalized ornament. Contact Jody (402) 826-6581 for more information (Cost \$25). Sponsored by the Crete Area Health Care Foundation.
- 5 - 9 p.m. PHONE HOME FOR THE HOLIDAYS - City Hall**  
Reach out to your family far and near this holiday season by making FREE international & domestic phone calls. Sponsored by Time Warner Cable.

## Saturday, Dec. 1

- 8 - 11 a.m. BREAKFAST WITH SANTA - Crete Elementary School**  
Visit Santa and enjoy a complimentary nutritious breakfast. Sponsored by Crete FBLA, Crete Chamber of Commerce & Public Health Solutions District Health Dept. Purchase home baked goods at the Crete Area Medical Center Ladies Auxiliary bake sale and gift drawing. Kids can shop for mom and dad at the Beta Sigma Phi Children's Gift Shop in the school library.
- 11 a.m. & 1 p.m. HOLIDAY STORY HOUR - Crete Public Library**  
Enjoy holiday stories, crafts & snacks (recommended ages 3 - 8, FREE). Sponsored by Bunge Milling.
- 9 a.m. - 3 p.m. HOLIDAY ARTS & CRAFT SHOW - Doane College/Fuhrer Field House**  
Start your holiday shopping early at the Crete Chamber of Commerce annual Arts & Craft Show.
- 10 a.m. - 2 p.m. WINTER FUN IN THE PARK - City Park**  
Ice Sculpting, Horse & Carriage Rides (FREE), International Tree Display, K.c. Memorial Railway Train Rides (FREE), Music & more. Sponsored by Doane College, Nestle Purina Pet Care Company, Crete Area Medical Center & Crete Sertama Club.
- 9 a.m. - 2 p.m. PHONE HOME FOR THE HOLIDAYS - City Hall**  
Reach out to your family far and near this holiday season by making FREE international & domestic phone calls. Sponsored by Time Warner Cable.
- 2 p.m. HOLIDAY MOVIE AT THE ISIS - "POLAR EXPRESS"**  
Free will admission: A can of food, new toy for Toys for Tots, or cash for Crete Cares. Sponsored by Pinnacle Bank.
- 2 - 5 p.m. CELEBRATE CRETE PHOTOGRAPHY CONTEST SHOWING - Crete ATA Academy**  
Entry forms available at local businesses, or contact Bob Muckel at (402) 643-0255. Sponsored by Doane College.
- 7 - 9 p.m. WINE & CHEESE RECEPTION**  
View the work of local photographers at Crete ATA Academy. Enjoy a sampling of wine and cheese (Cost \$10). Sponsored by Doane College & Prime Country Winery.

## Sunday, Dec. 2

- 11 a.m. & 1:30 p.m. WINTER WONDERLAND WALK**  
Enjoy the fresh fall air and explore Crete's newest trail system at Tuxedo Park (FREE). Bring your binoculars! Sponsored by Crete Youth Governance Team.
- 11 a.m. - 4 p.m. COMMUNITY SOUP LUNCHEON - Crete High School**  
Enjoy home-cooked soup & help raise funds for the Crete Backpack Program (Free Will Donation). Sponsored by the Crete Ministerial Association.
- 1 - 5 p.m. HOLIDAY TOUR OF HOMES**  
Tour area homes who's owners have decked the halls. Contact Cheryl Retherford for tickets (402) 826-5451 (Cost \$10). Sponsored by Crete Area Medical Center Ladies' Auxiliary
- 4 p.m. FESTIVAL OF LESSONS & CAROLS**  
Enjoy scripture and song, celebrating the birth of Christ - Presented by Trinity Memorial Church (14th & Juniper). Dessert reception to follow.
- 5 - 6 p.m. BENNE MUSEUM OPEN HOUSE & EXHIBIT DEDICATION**  
Be among the first to see new historical museum exhibits, including an exhibit in honor of Mrs. Benjamin Miller - Founder of the first Living Christmas Tree in Crete and the designer of the Nebraska State Flag (Cost \$5 - included with Tour of Home ticket). Refreshments provided. Sponsored by Crete Heritage Society.

**SHOP CRETE FIRST PROMOTION • HOLIDAY LIGHTS CONTEST •  
LOCAL FOOD & DINING SPECIALS • CRETE WINTERLUDE COMMEMORATIVE ORNAMENT  
• KIDS COLOR CONTEST • "SNOWMEN AT NIGHT" STORYWALK • AND MORE.**

For more information, call Marilea at (402) 826-6775.  
[www.crete-ne.gov](http://www.crete-ne.gov)

**WINTER FUN IN THE PARK**  
SATURDAY, DEC. 1  
10 A.M. TO 2 P.M.

Sip some hot cocoa and enjoy the sites and sounds of the season at City Park.

- Ice Sculpting beginning at 10 a.m.
- Free horse and carriage rides
- K.C. Jones Memorial Railway Train Rides
- International Tree Display
- Entertainment on the hour - 10 a.m., 11 a.m., 12 p.m., 1 p.m. & 2 p.m.

**SHOP CRETE FIRST & WIN**

Win \$1,000 in Crete Holiday Bucks or other great prizes by shopping Crete First! Pick up your Shop Crete First punch card at local retailers. For every \$10 you spend, you will receive a punch. Ten punches completes your card and makes you eligible for the prize drawing.

**CELEBRATE CRETE PHOTO CONTEST**

Celebrate the people, places, pets and nature that make Crete special.

- 1ST PLACE AWARDS IN EACH CATEGORY (\$50)
- OVERALL GRAND PRIZE WINNER "BEST PHOTO DEPICTING CRETE" (\$100)

Rules and Entry forms available by contacting Robert Muckel at [robert.muckel@doane.edu](mailto:robert.muckel@doane.edu) or visit [www.crete-ne.gov](http://www.crete-ne.gov)

**KIDS COLORING CONTEST**  
11/20 through 12/20

Showcase the talents of your little artist at the True Value Kids Coloring Contest. Pick up coloring pages ONLY at True Value.

AGE GROUPS:

- 0-3 YEARS, 4-6 YEARS, 7-9 YEARS, 10-14 YEARS, 15 YEARS OR OLDER

Prize for 1st in each group.

**DOWNTOWN STORYWALK**

Enjoy Crete Public Library's downtown StoryWalk! The entire family can start at Crete Foodmart for the beginning of "Snowmen at Night" by Caralyn Buehner. Continue walking up and down Main Street to read the story. There are 15 businesses in all with part of the story in their window.

**COMMEMORATIVE WINTERLUDE ORNAMENT**

Remember this Winterlude Festival with a commemorative ornament designed by local artist, Echo Easton. This holiday keepsake will become a Winterlude tradition, depicting memorable moments of each passing festival. Ornaments will be available at local businesses and at events throughout the weekend. Cost \$20.

**HOLIDAY LIGHTS CONTEST**

Winterlude Holiday Lighting and Decorating Contest sponsored by The Crete News. The contest will have two divisions, residential and business, to encourage participation in Crete's neighborhoods as well as with our merchants. Register your location prior to the Winterlude Festival, when all locations must be ready for viewing. Each participant must turn in the following information to The Crete News by, Nov. 30:

- Residential - Name, address and phone number,
- Business - Name of business/contact, address and phone number.

Please submit information to:  
The Crete News office or  
e-mail to [newsdesk@creteneews.net](mailto:newsdesk@creteneews.net)

**TREE OF LIGHTS CELEBRATION**  
FRIDAY, NOV. 30 • 7 P.M.

Remember and honor your loved ones this holiday season at the Crete Area Health Care Foundation's annual Tree of Lights. With a \$25 donation, your loved one's name will be read during the tree lighting ceremony. You will receive a personalized ornament etched with your loved one's name. Ornaments will be displayed on the Christmas Tree at Crete Area Medical Center throughout the holiday season. Your personalized ornament is yours to keep for years to come. Visit [www.bryanhealth.org/CAHCF](http://www.bryanhealth.org/CAHCF) to download a donation form or call Jody at (402) 826-6581.

**HOLIDAY TOUR OF HOMES**  
SUNDAY, DEC. 2 • 1-5 P.M.

The Holiday Tour of Homes will feature the homes of Drs. Jason & Kate Hesser, Mr. & Mrs. Steve Teget, Mr. & Mrs. Ron Schroeder, and Mr. & Mrs. Terry Petracek. In addition to these homes, the historic Jesse C. Bickel House (the "Maples") joins the tour, as well as District #1 Star School house which will be decorated with traditional holiday fare by local elementary students. No photos are allowed. The tour concludes at the Benne Memorial Museum with refreshments and the dedication of new museum exhibits. Cost is \$10. Contact Cheryl Retherford at (402) 826-5451 for tickets. - Sponsored by Crete Area Medical Center Ladies Auxiliary

Economic Development Program  
Recommendation Form

Applicant: Crete Chamber of Commerce

Public Hearing Date: 1/23/13 and 1/30/13

Criteria Met:

Allowed Activity: Tourism (#1-15)

Eligible Entity: Nonprofit (#1-11)

Entity: Startup (startup, buyout, existing)

Request:

Application Amount: 3500 (grant or income guarantee)

Term: Lump (lump sum or number of years)

Matching Funds: Funds Raised Program: \_\_\_\_\_  
with events + donations

Economic Impact: \_\_\_\_\_ (dollars) and/or \_\_\_\_\_ (jobs) and/or \_\_\_\_\_ (other value)

Recommendation:

Recommend funding \$ 3500 : Expressed budgeting in

Recommend partially funding \$ \_\_\_\_\_ advance and use of

Do not recommend funding \_\_\_\_\_ local businesses

Expenditure Category:  Infrastructure/Real Estate Purchase/Development

Promotion/Tourism

Business/Professional Recruitment & Retention

Council Meeting date: \_\_\_\_\_

Shayla  
Shaylene M. Smith, Chair

**Crete Economic Development Advisory Board  
Executive Director Job Description**

**Job Title:** City of Crete Economic Development Director  
**Reports to:** Crete Economic Development Advisory Board  
**Prepared by:** Crete Economic Development Advisory Board  
**Prepared Date:** January 30, 2013

**SUMMARY**

Under the direction of the Crete Economic Development Advisory Board, the Director coordinates all activities, programs, and operations of the Crete Economic Development Advisory Board in an efficient and effective manner. The Director implements activities focusing on business retention and economic development while preserving the quality of life in Crete, Nebraska. The Director also serves as a Liaison to the Chamber of Commerce, the Crete Area Improvement and Development Corporation and the City Planning Commission and assists to carry out the overarching mission of the Crete Economic Development Plan as approved by the voters in 2011 and additional plans and goals adopted by various factions of the community. This position will be a three year contract to be funded in part by the Economic Development Board administration budget and in part by other factions of the Crete community. The funding for this position will be self-limited, therefore, the successful candidate will work to seek additional revenue sources for the position subsequent to the first contract.

**ESSENTIAL DUTIES AND RESPONSIBILITIES** include the following (other duties may be assigned):

- 1.10 Work with state, federal, and utility resource entities to serve all of Crete in search of project assistance.
- 1.11 Handle distribution of LB 840 funding applications and assist applicants as needed through the application process.
- 1.12 Assisting with scheduling of quarterly Economic Development Advisory Board meetings and prepare materials necessary for the meeting, including scanning and disseminating notices, reports and applications.
- 1.13 Attend City Council, Economic Development Advisory Board, Chamber of Commerce Board, CAIDC and City Planning Commission meetings when able to do so.
- 1.14 Develop material to be included in Crete News and the Chamber of Commerce newsletter and/or develop and disseminate a separate Economic Development newsletter for the key players in Crete as well as other key contacts in the State.
- 1.15 Oversee compilation of information for publication and timely update of the community.
- 1.16 Develop and maintain a web presence for the purpose of fostering economic development and the City of Crete and coordinate weblinks for the benefit of the various factions of the community with an interest in economic development. This may include adding community updates to NEDI (Nebraska Economic Development Information) Community Profile System online.

- 1.17 Emphasize the importance of community updates to LOIS (Location One Information System) online.
- 1.18 Monitor and assist when appropriate for city-wide events which promote the community and increase tourism in Crete.
- 1.19 Develop marketing tools for Crete in conjunction with other community entities.
- 1.20 Attend meetings, conferences, and workshops that are determined to enhance the skills and encourage networking necessary for this position.
- 1.21 Gather information from area newspapers and newsletters as they relate to the Crete area projects and applications and update all applicant files through project completion as needed for public records and/or audit purposes.
- 1.22 Develop and maintain a comprehensive inventory of available buildings and sites in the Crete area for economic purposes and to track business movement into and out of the area.
- 1.23 Encourage business retention and expansion through personal contact.
- 1.24 Maintain visibility at the community level.
- 1.25 Form partnerships with area businesses, service organizations and Doane College to promote Crete Economic Development and business training participation.
- 1.26 Promote improvement of business conditions.
- 1.27 Write grants, or assist in consolidating information from resource entities to use in writing grants that will benefit Crete.
- 1.28 Develop an annual action plan through as a result of an annual Strategic Planning process with the Economic Development Board.
- 1.29 Assist the Chamber of Commerce and City Council in development of a coordinated marketing plan.
- 1.30 Develop Economic Development committees as deemed appropriate to incorporate other community leaders with special skills.
- 1.31 React to community business concerns quickly by offering personalized assistance.
- 1.32 Conduct general office practices to maintain efficiency.
- 1.33 Maintain an office schedule that encourages the open door policy but allows for attendance at required evening meetings.
- 1.34 Monitor and respond to email and telephone contacts in a timely manner.
- 1.35 Maintain and develop good contacts with State and Local officials, government entities, organizations, districts and the media.
- 1.36 Prioritize duties to accommodate requests for proposals and site prospect visits as opportunity presents.
- 1.37 Develop both short term and long term economic plans and programs not only to enhance current activity in the area, but to encourage future activity.
- 1.38 Monitor local, state, and federal legislation and regulations relating to economic development, and report findings and trends to the Economic Development Advisory Board and other community factions and leaders when prudent.
- 1.39 Promote a positive interaction with community groups and the media.
- 1.40 Participate in the promotion of tourism in Crete.
- 1.41 Encourage youth involvement in city planning.

- 1.42 Administer the .5% sales tax fund for Economic Development and comply with the budgeting and reporting requirements of the Crete Economic Development Advisory Board.
- 1.43 Collaborate with the City of Crete, the Economic Development Advisory Board, CAIDC and the Chamber of Commerce with annual or other consolidated meetings which benefit the City of Crete.
- 1.44 Coordinate fundraising efforts from public and private sources to secure a strong financial foundation for development.
- 1.45 Prioritize housing and commercial real estate needs within the city and work with the City of Crete to develop a plan to address those needs.
- 1.46 Represent Crete Economic Development at State and Regional Chamber and Economic Development organization meetings and seminars

### **QUALIFICATIONS**

To perform this job successfully, an individual must be able to accomplish essential duties satisfactorily. The requirements listed below are representative of the knowledge, skill, and/or ability needed. Reasonable accommodations may be made to enable individuals with disabilities to perform the essential functions. Individual must exhibit independence in duties that require travel or night meeting times.

### **EDUCATION AND/OR EXPERIENCE**

- 2.10 Completion of Bachelor's Degree is required.
- 2.11 Advanced education will be considered but is not required.
- 2.12 Previous experience in community work, grant writing, fund raising, marketing, and other related fields will be considered.

### **LANGUAGE SKILLS**

- 3.10 Requires the ability to communicate clearly and accurately in both written and verbal formats.
- 3.11 Bi-lingual abilities are encouraged.

### **MATHEMATICAL SKILLS**

- 4.10 Requires the ability to create and interpret an annual budget.
- 4.11 Requires competence in basic mathematical skills.
- 4.12 Computer spreadsheet skills are required to create, update, and maintain financial data.

### **COMPUTER SKILLS**

- 5.10 Must be proficient in Microsoft Office programs, including Word, Excel, Publisher and Power Point
- 5.11 Must be proficient in QuickBooks
- 5.12 Proficiency in pdf conversion and consolidation of multiple file types
- 5.13 Proficiency in email transmission, document attachment, and maintenance of email contact database is required. Communication with committees and resource providers via email is encouraged.

## **OTHER SKILLS AND ABILITIES**

- 6.10 Must exhibit knowledge and ability to operate all office equipment.
- 6.11 Ability to personally cover expenses for certain activities and costs associated with the position pending monthly reimbursement.
- 6.12 Ability to be bonded.
- 6.13 Strong organization, planning and time management skills.
- 6.14 Ability to maintain confidentiality.
- 6.15 Ability to establish and maintain effective working relations with community leaders, board members and general members of the public.
- 6.16 Ability to be a self-starter with initiative, drive and ambition. Sales and Marketing skills are encouraged as well as interpersonal skills.
- 6.17 Ability to maintain regular attendance on the job.
- 6.18 Must have a valid Nebraska driver's license.

## **PHYSICAL DEMANDS**

The physical demands described here are representative of traits deemed necessary to successfully perform the essential functions of this job. Reasonable accommodations may be made to enable individuals with disabilities to perform the essential functions. The position will require extended driving, typing, reading a computer monitor and small lifting.

## **WORK ENVIRONMENT**

- 7.10 Reasonable accommodations may be made to enable individuals with disabilities to perform the essential functions.
- 7.11 Modifications to work space may be considered to allow for work efficiency.

## **ADDITIONAL SPECIFICS OF POSITION:**

- 7.10 Executive Director is required to live in the Crete area.
- 7.11 Evening and weekend hours required.
- 7.12 Some travel required.
- 7.13 Salary commensurate with experience.
- 7.14 All skills, qualities and duties subject to annual review.

ORDINANCE NO. 1834

AN ORDINANCE OF THE CITY OF CRETE, NEBRASKA, TO AMEND ORDINANCE #1812; PERTAINING TO MUNICIPAL WATER DEPARTMENT; RATES; CHANGING EFFECTIVE DATE FROM AUGUST 1, 2012 TO OCTOBER 1, 2012; PROVIDING FOR THE REPEAL OF ALL ORDINANCES AND PARTS OF ORDINANCES IN CONFLICT HEREWITH; PROVIDING FOR PUBLICATION OF THIS ORDINANCE IN PAMPHLET FORM; AND PROVIDING WHEN THIS ORDINANCE SHALL BE IN FULL FORCE AND EFFECT.

BE IT ORDAINED BY THE MAYOR AND COUNCIL OF THE CITY OF CRETE, NEBRASKA:

Section 1. That the effective date of change in water rates set forth in ordinance #1812 is hereby amended from August 1, 2012 to October 1, 2012.

Section 2: That ordinance #1812 be amended as set forth herein and all other ordinances and parts of ordinances in conflict herewith are hereby repealed.

Section 3: That this ordinance shall take effect and be in full force and effect from and after its passage, approval and publication in pamphlet form, as provided by law.

PASSED AND APPROVED this 21st day of August, 2012.

ATTEST:

\_\_\_\_\_  
MAYOR

\_\_\_\_\_  
CITY CLERK

(SEAL)

**CHAPTER 3  
DEPARTMENTS  
Article 2. Water Department**

shall use due and reasonable diligence to provide and supply uninterrupted service to customers, but shall not be liable for damages resulting from interruption of service due to line breaks, freezing, or other causes over which the City has no control, for damages arising out of any plumbing or equipment inside any building whether inspected by agents of the City or not, and the City expressly reserves the right to refuse to connect or to discontinue or disconnect customer's service without any preliminary notice, for reasons set forth in this Article or for any other reason. The customer shall have interior house plumbing or other plumbing about the place or premises in which water service is to be used, done by a licensed and bonded plumber, but under no circumstances shall connections be made with the pipes of the water distribution system and supply pipes of the City and the pipes of the customer except at the order of the Public Works Director. All plumbing of customers shall be installed in accordance with the rules of the Uniform Plumbing Code incorporated by reference in Chapter 9.

**§3-223 MUNICIPAL WATER DEPARTMENT; RATES.** The following monthly rate schedules shall apply to all customers of the Municipal Water Department, according to the applicable service classifications:

A. MINIMUM MONTHLY SERVICE CHARGE: This charge is determined by the size of the meter through which the customer receives service according to the following table for service under all classifications except CASH WATER SALES:

Beginning October 1, 2012

METER SIZE	METER EQUIVALENT	MONTHLY SERVICE CHARGE
5/8"	1 (Standard)	\$ 10.20
3/4"	1.67	16.68
1"	2.67	16.68
1 1/2"	3.33	33.78
2"	5.33	54.00
3"	10.00	100.80
4"	16.66	168.35

Beginning August 1, 2013

METER SIZE	METER EQUIVALENT	MONTHLY SERVICE CHARGE
5/8"	1 (Standard)	\$ 12.75
3/4"	1.67	20.85

CHAPTER 3  
DEPARTMENTS  
Article 2. Water Department

1"	2.67	20.85
1 1/2"	3.33	42.23
2"	5.33	67.50
3"	10.00	126.00
4"	16.66	210.44

Beginning August 1, 2014

METER SIZE	METER EQUIVALENT	MONTHLY SERVICE CHARGE
5/8"	1 (Standard)	\$ 14.45
3/4"	1.67	23.63
1"	2.67	23.63
1 1/2"	3.33	47.86
2"	5.33	76.50
3"	10.00	142.80
4"	16.66	238.49

Beginning August 1, 2015

METER SIZE	METER EQUIVALENT	MONTHLY SERVICE CHARGE
5/8"	1 (Standard)	\$ 16.15
3/4"	1.67	26.41
1"	2.67	26.41
1 1/2"	3.33	53.49
2"	5.33	85.50
3"	10.00	159.60
4"	16.66	266.55

B. COMMODITY CHARGE: This charge is determined by the amount of water measured through the meter which the customer receives according to the following table for all classifications except CASH WATER SALES:

Beginning October 1, 2012

- \$1.43 per 1,000 gallons for the first 50,000 gallons used per month;
- 1.19 per 1,000 gallons for the next 50,000 gallons used per month;
- 1.19 per 1,000 gallons for over 100,000 gallons used per month

Beginning August 1, 2013

- \$1.28 per 1,000 gallons for the first 50,000 gallons used per month;
- 1.06 per 1,000 gallons for the next 50,000 gallons used per month;

CHAPTER 3  
DEPARTMENTS

Article 2. Water Department

1.06 per 1,000 gallons for over 100,000 gallons used per month

Beginning August 1, 2014

\$1.13 per 1,000 gallons for the first 50,000 gallons used per month;

1.94 per 1,000 gallons for the next 50,000 gallons used per month;

1.94 per 1,000 gallons for over 100,000 gallons used per month

Beginning August 1, 2015

\$0.98 per 1,000 gallons for the first 50,000 gallons used per month;

0.81 per 1,000 gallons for the next 50,000 gallons used per month;

0.81 per 1,000 gallons for over 100,000 gallons used per month

C. OFF-PEAK SERVICE: BL In addition to the minimum monthly service charge the following shall be paid for water metered.

\$0.60 per 1,000 gallons per month for all use

D. CASH WATER SALES: CW

\$3.00 per 1,000 gallons for all use, with a \$3.00 minimum per request

*(Amended by Ord. Nos. 1035, 5/9/87; 1193, 7/20/93; 1276, 7/5/95; 1686, 08/07/07; 1812, 11/15/11; 1834, 8/21/12)*

**§3-224 MUNICIPAL WATER DEPARTMENT; MULTIPLE-OCCUPANCY SERVICE.**

Individual water meters must be installed for each occupancy in all multiple occupancy facilities, i.e., apartment houses, trailer courts, mobile homes, apartments, condominiums, or other multiple family dwellings constructed from and after the passage of this ordinance. The owner of all such multiple occupancy facilities in existence at the time of the passage of this ordinance are required to install individual water meters for each occupancy by January 1, 1996, or pay a rate adjusted on a "per occupancy" basis. (Ord. No. 1066, 2/7/89) (Amended by Ord. No, 1194, 7/6/93)

**§3-225 MUNICIPAL WATER DEPARTMENT; FEES AND CHARGES.**

ORDINANCE NO. 1848

AN ORDINANCE OF THE CITY OF CRETE, NEBRASKA, TO AMEND ORDINANCE #1812; PERTAINING TO MUNICIPAL WATER DEPARTMENT; RATES; CHANGING EFFECTIVE DATE FROM AUGUST 1 TO OCTOBER 1; PROVIDING FOR THE REPEAL OF ALL ORDINANCES AND PARTS OF ORDINANCES IN CONFLICT HEREWITH; PROVIDING FOR PUBLICATION OF THIS ORDINANCE IN PAMPHLET FORM; AND PROVIDING WHEN THIS ORDINANCE SHALL BE IN FULL FORCE AND EFFECT.

BE IT ORDAINED BY THE MAYOR AND COUNCIL OF THE CITY OF CRETE, NEBRASKA:

Section 1. That the effective date of the yearly change in water rates - minimum monthly service charge and commodity charge, set forth in ordinance #1812 are hereby amended as follows, to-wit:

- August 1, 2012 to October 1, 2012;
- August 1, 2013 to October 1, 2013;
- August 1, 2014 to October 1, 2014; and
- August 1, 2015 to October 1, 2015;

Section 2: That ordinance #1812 be amended as set forth herein and all other ordinances and parts of ordinances in conflict herewith are hereby repealed.

Section 3: That this ordinance shall take effect and be in full force and effect from and after its passage, approval and publication in pamphlet form, as provided by law.

PASSED AND APPROVED this 5th day of February, 2013.

ATTEST:

\_\_\_\_\_  
MAYOR

\_\_\_\_\_  
CITY CLERK

(SEAL)

(This page left intentionally blank)

**Resolution 2013-07**  
**Member Resolutions for Appointments**

***Representative and Alternate Representative to MEAN Management Committee***

WHEREAS, the City of Crete, State of Nebraska, is a part to the Electrical Resource Pool Agreement and, pursuant to the terms of such Agreement, it is the responsibility of the City of Crete to designate a representative and alternate representative to the Municipal Energy Agency of Nebraska Management Committee provided for under the terms of said Agreement.

NOW THEREFORE, BE IT RESOLVED by the City Council of the City of Crete, State of Nebraska, that:

1. The City Clerk is hereby directed to give written notice to the Municipal Energy Agency of Nebraska of the appointment of Tom Ourada as representative to said MEAN Management Committee.
2. The City Clerk is hereby directed to give written notice to the Municipal Energy Agency of Nebraska of the appointment of Mike Kalkwarf as alternate representative to said MEAN Management Committee.

***Director and Alternate Director to MEAN Board of Directors***

This is to certify that the City Council of the City of Crete, State of Nebraska duly appointed Tom Ourada to serve as director to represent the City of Crete on the Board of Directors of the Municipal Energy Agency of Nebraska. The appointment will run for a term of three (3) years with the powers and duties incident to such office. This certificate is issued in compliance with the Municipal Cooperative Financing Act contained in the Nebraska Revised Statutes §18-2401 et. seq. (1987).

This is to certify that the City Council of the City of Crete, State of Nebraska duly appointed Mike Kalkwarf to serve as alternate director to represent the City of Crete on the Board of Directors of the Municipal Energy Agency of Nebraska. The appointment will run for a term of three (3) years with the powers and duties incident to such office. This certificate is issued in compliance with the Municipal Cooperative Financing Act contained in the Nebraska Revised Statutes §18-2401 et. seq. (1987).

*This is to certify that the appointments set out above were approved by the City Council of the City of Crete, State of Nebraska, at their meeting on February 5, 2013.*

ATTEST:

\_\_\_\_\_  
Mayor

\_\_\_\_\_  
City Clerk  
(SEAL)

RESOLUTION \_\_\_\_\_

WHEREAS, the City of Crete (City) is the owner of certain item(s) of personal property (property), to-wit:

1. 1996 Street Sweeper (P2033D)
2. 1961 Dump Truck (SB208076E),

and

WHEREAS, the property is no longer used and or/ needed for use by the City and it is in the best interest of the City that the property be declared to be surplus personal property and sold.

NOW, THEREFORE, BE IT RESOLVED BY THE CITY OF CRETE, NEBRASKA:

That said property more specifically described herein is/ are hereby declared to be surplus personal property, that it is in the best interest of the City that said property be sold and that the Mayor is authorized to deliver a bill of sale after sale of the property and upon payment of the sale price to the City.

Dated this \_\_\_ day of February, 2013.

\_\_\_\_\_  
MAYOR

ATTEST: \_\_\_\_\_  
CITY CLERK

**CITY OF CRETE, NEBRASKA**  
**Planning Commission**  
**January 28, 2013**

Notice of the meeting was given by posting and publishing in The Crete News, the appointed method for giving notice as shown by the Proof of Publication attached to the minutes. Advance notice of the meeting also given to the board members. Pursuant to Section 84-1412(8) of the Nebraska Open Meetings Act, the City has posted a current copy of the Open Meetings Act, Laws of the State of Nebraska, in the back of the Council Chambers. Additional copies are available to read. The board may consider items listed on the agenda in random order. All proceedings shown were taken while the meeting was open to the attendance of the public.

The meeting was called to order by Chairman Hanson. Members present: Dave Hanson, Harold Jones, Scott Kuncl, Ryan Jindra, Ron Dittmer and Shirley Siedhoff. Members absent: Sharon Scusa and Janet Bonneau. Also present: Public Works Director Tom Ourada, Building Inspector Ray Sueper and City Attorney Steve Reisdorff.

**Approval of December 17, 2012 Minutes**

Kuncl made a motion, seconded by Siedhoff to approve the minutes of December 17, 2012 as written. Voting “aye”: Jones, Kuncl, Jindra, Dittmer, Siedhoff and Hanson. Voting no: None. Absent: Scusa and Bonneau.

**Mardock request for replat of Crete Industrial Park subdivision**

After some discussion, Reisdorff informed the Commissioners that Mayor Foster would like time for the Council to review the special exception request. Siedhoff made a motion to table the request for replat until the City Council reviews the special exception request. This was seconded by Jones. Voting “aye”: Jones, Kuncl, Jindra, Dittmer, Siedhoff and Hanson. Voting no: None. Absent: Scusa and Bonneau.

**Building Code update presentation**

Sueper gave a power point presentation on the 2009 building code updates. Dittmer made a motion to schedule a public hearing for February 25, 2013 at 7:05 p.m. Kuncl seconded the motion. Voting “aye”: Jones, Kuncl, Jindra, Dittmer, Siedhoff and Hanson. Voting no: None. Absent: Scusa and Bonneau.

**Discuss Comprehensive Plan Update**

Ourada stated Council is in favor of a new comprehensive plan. Hiring a comprehensive planner was discussed by the commissioners. The Economic Development Committee recommended waiting until the 2<sup>nd</sup> quarter to apply to LB840 for funding for this. In preparation for hiring a planner Kuncl made a motion to request Ourada draft a RFP (Request for Proposal), with Siedhoff seconding the motion. Voting “aye”: Jones, Kuncl, Jindra, Dittmer, Siedhoff and Hanson. Voting no: None. Absent: Scusa and Bonneau.

**Set Hearing Date for 1 – 6 Year Plan**

The commissioners have the opportunity to add, change or discuss changes with Ourada for the 1 – 6 Year Plan. Kuncl made a motion to schedule the public hearing for February 25, 2013 at 7:15 p.m. The motion was seconded by Dittmer. Voting “aye”: Jones, Kuncl, Jindra, Dittmer, Siedhoff and Hanson. Voting no: None. Absent: Scusa and Bonneau.

Meeting adjourned.

Recorded by Jera Novak

# Crete Fire & Rescue Department

P.O. Box 411  
Crete, Nebraska 68333  
(402) 826-FIRE (3473)



January Officers Meeting  
January 29, 2013

1900 hours

President Oelschlager called the officers meeting of the Crete Volunteer Fire & Rescue Department to order at 1912 hours with 9 officers in attendance.

President Oelschlager read the open meeting rules: The Fire & Rescue Department has posted a copy of the open meetings ACT. Laws of the State of Nebraska, in the back of the meeting room, additional copies are available to read. If anyone wishes one during this meeting please advise. As each agenda item is considered, if there are any questions concerning the agenda item please make us aware of this request.

## Officers Reports

### Chief Tod Allen:

#### 1. Presented Mutual Aid Meeting Report.

- Saline County is looking into having a "mini-fire school. There will be a meeting in Wilber on February 6<sup>th</sup>. At this meeting the purchase of a tanker from the Forestry Service for county mutual aid use will also be discussed. Details and specifics will be discussed in greater depth at the meeting.
- Training grounds will be open for utilization by any department that wishes. We will also offer to staff their station during the time that they are training.
- Dewitt has a mobile outhouse that may be utilized by other department as needed.
- Saline County Emergency Management is attempting to obtain an Emergency Management trailer with rehabilitation capabilities.

2. Discussed E-Dispatch and interest in potential use in the future. County may share in cost of the program with the department; Jordan will conduct research on the system and report back at February officers meeting.

3. Discussed "Storm Spotter" program. This program will be discussed with department at February meeting. Additional training will need to be pursued.

4. Farmland walk through will be February 11, 2013. A signup sheet will be posted.

5. Milford Road construction will resume April 15, 2013. Discussed use of current and updated maps.

6. Command Structure reinforcement. We will utilize a formal command structure on all calls. Officers are to speak with the Chief if any clarification is needed.

7. Apparatus committee needs to be created to begin specifications for progression with engine purchase.

8. Missing diesel charge receipt issue has been resolved within another department.

9. We now have a hard copy of our supplemental insurance policy. A copy will be provided to all department members. Chief will look into having the agent speak at February department meeting

10. Gantry Crane will be moved to the training grounds.

### Assistant Chief Rod Kuss:

1. Training burn of cabin at Tuxedo park in December. Reinforced safety issues and proper gear for trainings.

2. Dorchester training burn in December was a good experience. Productive training.

### Fire Captain Josh Page:

1. Discussed possible purchases from Forestry Service including flood light system. Fire officers will meet with contact with in the month and report back.

2. Discussed 90 leaving first on MVC. Topic will be researched and discussed at February officers meeting.

3. Presented possible options for new forms to be utilized for fire reports. MVC form will need to be amended/reformatted; Steph will look into MVC forms and report back.
4. Discussed who will fill out fire field reports. Commanding officer will be responsible for completing the form/report. Possible monthly rotation for entering written reports into electronic form.
5. Gas monitor: Researching new monitor. Potential cost could range from \$1200-\$1400 for the Altar 4 gas monitor. This will be reviewed as budget allows.

**Fire 1<sup>st</sup> Lieutenant Tim McFarland:**

1. Doane students have notified us of STOP day changes. Due to last year's events STOP day will now be centered around community service. They are requesting projects that will take 3-5 hours. Please notify Chief if you have any ideas and we can reply to Doane contact.
2. Implementation of recruit class and establishment of goals/standards for progression discussed.

**Fire 2<sup>nd</sup> Lieutenant Matt Bakker**

1. Implementation of vehicle certification process discussed: class time as well as supervised driving time. Field officers will meet Thursday, January 31, 2013 for further discussion.

**Rescue Captain James Yost:** Absent.

**Rescue 1<sup>st</sup> Lieutenant Terry Petracek:** Leave of Absence.

**Rescue 2<sup>nd</sup> Lieutenant Jordan Lampila:** Nothing to report at this time.

**Secretary Stephanie Weis:**

1. Please have any special order of business items or other items needing to be added to agenda turned in no later than the Sunday before scheduled meeting time.

**Treasurer Ashley Leeper:** Absent.

**Vice President Kirk Keller:**

1. Bunker gear
  - Need to finalize list and complete fitting.
  - Discussed cost vs budget for this year.
  - Possible 5 year rotation for gear replacement
  - Surplus gear: discussed options of what to do with gear that is no longer approved for service.

**President Jack Oelschlager:**

1. Budget Discussion:
  - Auditing committee – Investments; how to pursue legally.
  - Will present thoughts and ideas to department.
  - Explanation of reimbursement pay stubs.

**Committee Reports**

**Building Committee:**

- Bay lighting bid received. Approved to proceed and begin project. Discussed looking into obtaining bids for outdoor lighting as well.
- Tool room update: Discussed purchasing a parts washer ; tabled until next month.
- Still awaiting Smartboard cover bid.

**BBQ Committee:**

- Band contract has been signed.

**Scholarship Committee:**

- Applications need to be taken to the High School.
- Deadline for submitting applications will be April 1, 2013

**Dinner Dance Committee:**

- Discussed this years event and possible relocation for next years event.

#### Officers Meeting Minutes

The November officer's meeting minutes were presented to the officers. There was a motion by Tod Allen to approve meeting minutes as presented, 2<sup>nd</sup> by Kirk Keller motion carried.

#### Old Business

No old business to be discussed at this time.

#### New Business

- Disciplinary system for department discussed. Will review by-laws and consider amendments if needed.
- Brandon Smejdir and Adam Kuss have requested an extension on their EMT deadline .Motion to grant a six month extension by Josh Page. 2<sup>nd</sup> by Tim McFarland. Six month extension granted.
- City Wide Auction is in the works.
- Change of apparatus order presented. 90 will no longer be first out on structure fires. Tod will make contact with Public Safety Committee. New order will be presented to department at February department meeting before changes are implemented.

#### Special Order of Business

- Lafrance Update: Discussed tire purchase options. Will purchase tires for \$1400. Will present and update department at February meeting as purchase was previously approved.
- Job Descriptions : New job descriptions will be complete and presented to department for approval at February department meeting.
- Scuba Team. Dissolve? Will discuss with department before further action.
- Fire year plan discussed.

Motioned to adjourn at 2145 by Tod Allen, 2<sup>nd</sup> by Kirk Keller, motion carried. Meeting adjourned at 2145 hours.

Jack Oelschlager  
President Jack Oelschlager

Stephanie M. Weis  
Secretary Stephanie M. Weis

# LEGISLATIVE BULLETIN

## LEAGUE OF NEBRASKA MUNICIPALITIES

103rd Legislature, First Session

Jan. 18, 2013 - Bulletin 2



### ITEMS OF INTEREST TO MUNICIPALITIES

- **Governor delivers State of the State Address Jan. 15.**
- **Please note that in addition to the weekly *Legislative Bulletin*, the League staff will be holding weekly legislative briefings by telephone conference call starting Tuesday, Jan. 22, at 9 a.m. CST/8 a.m. MST. The purpose is for the League staff to update League members on key legislative issues and respond to questions. To participate, please call 1-916-209-4534 and enter access number 3971829.**
- **Bill introduction continues through Jan. 23.**
- **Committee hearings begin Jan. 22.**
- **Check the Legislature's web site for more information about your state Senators and the session. The web site address is <http://nebraskalegislature.gov/web/public/home>.**

**NOT ALL ITEMS OF INTEREST ARE INCLUDED ON THIS LIST.  
ALSO SEE THE REMAINDER OF THE LEGISLATIVE BULLETIN.**

## Governor delivers State of the State Address

*Heineman calls for increase in budget of 5.1% in FY 2013-2014 and 4.7% in FY 2014-2015. Also wants to eliminate income tax and corporate income tax.*

Gov. Dave Heineman Jan. 15 called for an increase in the state budget of 5.1 percent in FY 2013-2014 and 4.7 percent in FY 2014-15 during his annual State of the State Address before the Legislature. Separate from the Governor's budget proposal, Heineman called for eliminating the income tax and corporate income tax, asserting that Nebraska's tax system is outdated in a technology-driven, global economy.

"Life has changed drastically since the 1960s. We were operating in a completely different economic environment then," Heineman told lawmakers.

### **Budget increases**

During FY 2013-2014, Heineman called for an annual budget increase of \$185.3 million with \$77.6 million, or 41.8 percent of the increase, going for education, and \$98.7 million, or 53.3 percent of the increase going for health and human services costs. In FY 2014-2015, the Governor proposed a \$180.8 million annual increase with \$81.1 million, or 44.9 percent of the increase going for education, and \$89.1 million, or 49.3 percent of the increase, going for health and human services costs. The Governor's plan did not call for any tax increases.

"My proposed budget continues to make K-12 education a priority by increasing state aid to education from \$852 million to \$895 million in FY 2014 and to \$939 million in FY 2015," he said, adding that he also is proposing a 5 percent increase in special education funding in each of the next two years.

### **Tuition freeze**

Heineman told Senators that he and higher education leaders announced last week that they are prepared to implement a two-year tuition freeze for Nebraska students, if his proposed budget is adopted.

"My recommendation provides the necessary state funding to achieve this two-year tuition freeze for UNL, UNK, UNO, UNMC, Chadron State, Wayne State and Peru State," he said. "This is very good news for Nebraska families who are working very hard to ensure that their sons and daughters can afford to go to college."

### **Health care act costs**

Heineman said that it would cost more than \$170 million in federal and state funds over the next eight years to implement the technology and administration required for the Affordable Health Care Act. He also said it would cost the state \$72 million in general funds in this budget



*Gov. Dave Heineman*

to cover the growth of the current Medicaid program stemming from the federal health care act.

Heineman ended his address by promoting his tax reform proposal, contending that his proposal would be budget and revenue neutral by reducing some of the state's current business sales tax exemptions.

"By adopting a modern, simpler and fairer tax code, we have the opportunity to make Nebraska a top 10 business tax climate state so that our sons and daughters and new citizens can find jobs and careers right here in Nebraska," he said. "Let's begin this statewide conversation and together we will find a Nebraska common sense solution."

# 2013 legislative bills

One-line descriptions of bills are provided by the Clerk of the Legislature's Office.

◆ = Bills monitored by the League  
(League) = League-backed bills

## Introduction date: Jan. 11, 2013

**LB 115** (Lautenbaugh) Change provisions relating to homicide

**LB 116** (Harms) Provide requirements for dual-enrollment courses

◆ **LB 117** (Harms) Change provisions relating to permits for overweight vehicles

◆ **LB 118** (Harms) Change texting enforcement provisions

**LB 119** (Cook) State intent relating to appropriations for Public Health Aid

◆ **LB 120** (Lautenbaugh) Change provisions of the Uniform Residential Landlord and Tenant Act

**LB 121** (Lautenbaugh) Provide for waiver of a Nebraska certificate to administer

◆ **LB 122** (Lautenbaugh) Appropriate funds to the Department of Economic Development

**LB 123** (Lautenbaugh) Change distribution of indigent defense fees

**LB 124** (Lautenbaugh) Change provisions relating to grandparent visitation

**LB 125** (Lautenbaugh) Change provisions relating to boards of education of Class V school districts

**LB 126** (McGill) Provide for grants from the Court Appointed Special Advocate Fund

**LB 127** (McGill) Provide for preregistration to vote for 16 and 17 year olds

◆ **LB 128** (Coash) Create the offense of disarming a peace officer

**LB 129** (Haar) Change the compensation for members of the Board of Educational Lands and Funds

◆ **LB 130** (Mello) Eliminate Cash Reserve Fund transfers

**LB 131** (Nordquist) Adopt the Tobacco-Free Schools Act

**LB 132** (Nordquist) Adopt the Skin Cancer Prevention Act

◆ **LB 133** (Hadley) Provide priority of insurance coverage relating to motor vehicle dealer loaner vehicles

**LB 134** (Avery) Provide for inheritance by issue conceived after death

**LB 135** (Avery) Change membership provisions relating to Community College Boards of Governors

◆ **LB 136** (Avery) Provide for the distribution of administrative fines and costs and forfeited property

**LB 137** (Avery) Establish state fleet card programs

◆ **LB 138** (Krist) Create the Group Health Trust Fund and provide for investment and provide duties for the State Treasurer

**LB 139** (Krist) Change vital statistics information relating to annulment and dissolution of marriage

◆ **LB 140** (Krist) Change provisions of the Airport Zoning Act

◆ **LB 141** (Lathrop) Change court procedures for the Nebraska Workers' Compensation Court

◆ **LB 142** (Lathrop) Provide that probation records are not subject to disclosure as prescribed

**LB 143** (Bloomfield) Authorize schools to adopt a child sexual abuse policy as prescribed

**LB 144** (Brasch) Provide for write-in candidacy by defeated candidate

◆ **LB 145** (Brasch) Change valuation of agricultural land and horticultural land

# 2013 legislative bills

◆ **LB 146** (Gloor) Change provisions relating to funds transfers under the Uniform Commercial Code

**LB 147** (Gloor) Adopt the Health Carrier External Review Act

◆ **LB 148** (Ashford) Include ammunition in certain offenses involving firearms

◆ **LB 149** (Pirsch) Provide for biennial reviews of state agency programs and services

◆ **LB 150** (Nordquist) Change provisions relating to the sale of natural gas by metropolitan utilities districts and exempt certain purchases of energy and fuel from sales tax

**LB 151** (Seiler) Provide a hearsay exception for certain documents and data kept in the regular course of business

◆ **LB 152** (Dubas) Change eminent domain negotiations

◆ **LB 153** (Dubas) Change the Civic and Community Center Financing Act

◆ **LB 154** (Dubas) Redefine road assistance vehicle relating to drivers' duties to move over

◆ **LB 155** (Gloor) Change provisions relating to deposits of public funds in excess of insured or guaranteed amounts

◆ **LR 12CA** (Harms) Constitutional amendment to authorize a county manager form of county government

**LR 20** (Lathrop) Provide for continuation of the Developmental Disabilities Special Investigative Committee

## Introduction date: Jan. 14, 2013

**LB 156** (Watermeier) Eliminate a report made to the Department of Health and Human Services by counties utilizing a community service program

**LB 157** (Cook) State intent relating to the appropriation of funds in support of dental services

◆ **LB 158** (Seiler) Change provisions relating to eligibility for and use of ignition interlock devices

◆ **LB 159** (Schumacher) Provide and change sales tax provisions relating to gold, silver, and platinum and provide a tax amnesty

◆ **LB 160** (Schumacher) Provide for electronic signatures on recall, initiative, and referendum petitions

◆ **LB 161** (McGill) Change a penalty for violation of building ordinances or regulations of a city of the metropolitan class

**LB 162** (McGill) Provide for notification of eligibility for an associate degree as prescribed

**LB 163** (McGill) Provide for a report on education credentials and workforce needs

**LB 164** (Dubas) Change motor vehicle auction provisions

**LB 165** (Dubas) Change provisions relating to motor vehicle dealer warranty service

◆ **LB 166** (Schilz) Change labeling requirements for lawn and turf seed containers

**LB 167** (McCoy) Change balloting and vacancy provisions for presidential electors

**LB 168** (Larson) Authorize series limited liability companies

**LB 169** (Gloor) Change provisions relating to jury commissioners

◆ **LB 170** (Gloor) Rename and expand the purpose of the Nebraska Educational Finance Authority Act

◆ **LB 171** (Bloomfield) Provide for an expedited concealed handgun permit process for applicants who are victims of domestic violence

**LB 172** (Coash) Change court filings for guardianships and conservatorships

◆ **LB 173** (Coash) Change provisions relating to documentary proof of age under the Nebraska Liquor Control Act

# 2013 legislative bills

- ◆ **LB 174** (Mello) Change provisions relating to vehicle load contents and spillage
- ◆ **LB 175** (Smith) Change the persons authorized to represent Nebraska under the streamlined sales and use tax agreement
- ◆ **LB 176** (Smith) Exempt military retirement benefits from taxation as prescribed
- ◆ **LB 177** (Smith) Provide enforcement and penalty provisions to the Nebraska Wage Payment and Collection Act
- LB 178** (Kintner) Change provisions relating to transportation reimbursement and state aid relative to learning communities
- LB 179** (Kintner) Eliminate learning communities
- LB 180** (Adams) Provide for the waiver of education-related fees for dependents of veterans
- ◆ **LB 181** (Avery) Prohibit motorcycle passengers less than eight years old
- LB 182** (Avery) Change paternity provisions for a child conceived as a result of sexual assault
- ◆ **LB 183** (Karpisek) Provide for county board appointment of election commissioners
- ◆ **LB 184** (Haar) Appropriate funds for the Nebraska Wind Applications Center
- ◆ **LB 185** (Christensen) Authorize state assistance for streamflow enhancement projects undertaken by natural resources districts
- ◆ **LB 186** (Christensen) Restrict rule and regulation authority of natural resources districts
- LB 187** (Nelson) Appropriate funds to the Department of Health and Human Services to fund the Dental Health Director
- ◆ **LB 188** (Karpisek) Require legislative approval of gubernatorially appointed election commissioners
- ◆ **LB 189** (Harms) Change provisions and penalties relating to occupant protection systems
- LB 190** (Harms) Appropriate funds for the Early Childhood Education Endowment Cash Fund

- ◆ **LB 191** (Nordquist) Adopt the Nebraska Job Creation and Mainstreet Revitalization Act and provide tax credits
- ◆ **LB 192** (Karpisek) Change provisions relating to requests for information by the Auditor of Public Accounts
- ◆ **LB 193** (Nelson) Change funding for the Nebraska Cultural Preservation Endowment Fund

## Introduction date: Jan. 15, 2013

- ◆ **LB 194** (Speaker Adams) Provide for deficit appropriations
- ◆ **LB 195** (Speaker Adams) Appropriate funds for state government expenses
- LB 196** (Speaker Adams) Appropriate funds for salaries of members of the Legislature
- LB 197** (Speaker Adams) Appropriate funds for salaries of constitutional officers
- ◆ **LB 198** (Speaker Adams) Appropriate funds for capital construction and property acquisition
- ◆ **LB 199** (Speaker Adams) Provide fund transfers, create funds, and authorize the sale of land
- ◆ **LB 200** (Speaker Adams) Provide for transfers from the Cash Reserve Fund
- LB 201** (Haar) Authorize emergency expenditures by school districts and educational service units
- ◆ **LB 202** (Coash) Change provisions relating to DNA collection
- ◆ **LB 203** (Scheer) Change provisions relating to solid waste under the Environmental Protection Act
- ◆ **LB 204** (Larson) Change and provide criminal sanctions regarding animals and animal facilities
- LB 205** (Schumacher) Change provisions relating to application of the Securities Act of Nebraska
- ◆ **LB 206** (Schumacher) Require secret-ballot envelopes for mailed ballots
- ◆ **LB 207** (McCoy) Change motor vehicle registration provisions

# 2013 legislative bills

- ◆ **LB 208** (Harr) Change provisions relating to metropolitan utilities districts
  - ◆ **LB 209** (Harr) Change provisions relating to publication of trade names
  - LB 210** (Harr) Provide remedies and procedures regarding unauthorized financing statement filings
  - LB 211** (Adams) Change and eliminate provisions relating to statewide coordination of community college boards
  - LB 212** (Karpisek) Change court-ordered parenting plan provisions of the Parenting Act
  - LB 213** (Gloor) Change provisions relating to financial institutions
  - LB 214** (Gloor) Change provisions relating to securities and seller-assisted marketing plans
  - LB 215** (Schilz) Change provisions relating to use of the County Visitors Promotion Fund
  - LB 216** (McGill) Adopt the Young Adult Voluntary Services and Support Act
  - LB 217** (Avery) Change constitutional officers' salaries
  - LB 218** (Avery) Require insurance coverage for certain food formulas as prescribed
  - ◆ **LB 219** (Avery) Change petition requirements for general election ballot
  - LB 220** (Avery) Change children's eligibility provisions relating to the Medical Assistance Act
  - LB 221** (Karpisek) Change dental hygienist training and authorized functions
  - ◆ **LB 222** (McCoy) Change provisions regarding certain reports submitted electronically to the Legislature
  - ◆ **LB 223** (Janssen) Redefine utility-type vehicles
  - ◆ **LB 224** (Janssen) Provide veterans preference for public contracts as prescribed
  - LB 225** (Smith) Adopt the Newborn Critical Congenital Heart Disease Screening Act
  - ◆ **LB 226** (Smith) Regulate dealers in the business of purchasing and reselling precious items
  - ◆ **LB 227** (Kintner) Exclude retirement benefits from state income taxation
  - ◆ **LB 228** (Nordquist) Provide requirements relating to copayments, coinsurance, and deductibles relating to certain services
  - LB 229** (Nordquist) Change the Nebraska Retirement Fund for Judges fee
  - ◆ **LB 230** (Karpisek) Change shipping license provisions under the Nebraska Liquor Control Act
  - LB 231** (Nelson) Establish a uniform reimbursement rate for adult day services
  - LB 232** (Lathrop) Change judges' salaries
  - ◆ **LB 233** (Pirsch) Change award and report provisions under the Nebraska Crime Victim's Reparations Act
  - LB 234** (Howard) State intent relating to appropriations for nurse visitation
  - ◆ **LB 235** (Howard) Change precinct size requirements and procedures for drawing political subdivision boundaries and changing polling places and provide for election advisory committees
  - ◆ **LB 236** (Howard) Appropriate funds to Department of Labor to establish an individual development accounts pilot project
  - ◆ **LB 237** (Karpisek) Change provisions relating to a property tax exemption
  - ◆ **LB 238** (Crawford) Exempt social security and certain retirement benefits from state income taxation
- Introduction date: Jan. 16, 2013**
- LB 239** (Wightman) Adopt the Nebraska All-Payer Patient-Centered Medical Home Act

# 2013 legislative bills

- LB 240** (Harms) Change work activity requirements for self-sufficiency contracts under the Welfare Reform Act
- ◆ **LB 241** (Sullivan) Authorize voters to change election of county offices from partisan to nonpartisan
- ◆ **LB 242** (Howard) Change provisions relating to adoption of administrative rules and regulations
- LB 243** (Howard) Redefine nurse practitioner practice
- LB 244** (Brasch) Require apprentice electricians to complete continuing education
- LB 245** (Nordquist) Change preferred drug list provisions under the Medical Assistance Act
- ◆ **LB 246** (Larson) Provide for a health care copayment for jail and prison inmates
- ◆ **LB 247** (Larson) Change Nebraska Juvenile Code provisions relating to reimbursement by parents for costs of care and treatment
- ◆ **LB 248** (Larson) Provide for seasonal employers under the Employment Security Law
- ◆ **LB 249** (Dubas) Change motor vehicle provisions relating to farm vehicles and drivers transporting agricultural commodities or farm supplies
- ◆ **LB 250** (Dubas) Change motor vehicle provisions relating to issuance of trip permits
- ◆ **LB 251** (Hansen) Change a fee relating to the rental of motor vehicles
- LB 252** (Adams) Correct and change subdivision references and references to governmental entities related to postsecondary education
- LB 253** (Adams) Correct references in school statutes
- LB 254** (Adams) Correct references related to the Nebraska Educational Telecommunications Commission
- ◆ **LB 255** (McGill) Change provisions relating to hearsay, child abuse, and offenses relating to morals
- ◆ **LB 256** (McGill) Eliminate criminal forfeiture and provide for civil forfeiture as prescribed
- ◆ **LB 257** (McCoy) Change provisions relating to creation of municipal counties
- LB 258** (Sullivan) Prohibit use of certain wireless devices by school bus drivers as prescribed
- ◆ **LB 259** (Karpisek) Exempt keno writers from licensure under the Nebraska County and City Lottery Act
- LB 260** (Gloor) Change requirements for a data and information system under the Nebraska Behavioral Health Services Act
- LB 261** (Gloor) Adopt the Medicaid Insurance for Workers with Disabilities Act
- LB 262** (Cook) Provide duties relating to sharing of student information
- ◆ **LB 263** (Nebraska Retirement Systems Committee) Change provisions relating to government retirement systems
- ◆ **LB 264** (Bolz) Provide an income tax credit for individuals caring for dependents
- ◆ **LB 265** (Coash) Change foster care licensure and kinship home and relative home provisions
- ◆ **LB 266** (Chambers) Eliminate provisions relating to increases in local option sales tax rates
- ◆ **LB 267** (Chambers) Prohibit persons on parole, probation, or work release from acting as undercover agents or employees of law enforcement and prohibit admissibility of certain evidence
- LB 268** (Campbell) State intent to appropriate funds for upgrade of an electronic data collection system related to child welfare and other economic assistance programs

# 2013 legislative bills

**LB 269** (Campbell) Change provisions relating to children and families

**LB 270** (Campbell) Provide for a Medicaid state plan amendment relating to services for children with serious emotional disturbance

◆ **LB 271** (Lautenbaugh) Change provisions relating to early voting

◆ **LB 272** (Carlson) Change provisions relating to chemigation permits and fees

◆ **LB 273** (Karpisek) Change keno time limits

**LB 274** (Nordquist) Adopt the Education Compensation Transparency Act

**LB 275** (Nordquist) Adopt the Nebraska Coordinated School Health Act

**LB 276** (Nordquist) Change reimbursement provisions under the Early Intervention Act and require a Medicaid state plan amendment

**LB 277** (Harr) Change provisions relating to presentation of a false medicaid claim

◆ **LB 278** (Pirsch) Change provisions relating to fees charged by the Secretary of State

**LB 279** (Pirsch) Change provisions relating to loan brokers, delayed deposit services, and installment loans

◆ **LB 280** (Pirsch) Change domestic assault provisions

◆ **LB 281** (Pirsch) Change the amount of tax credits allowed under the Angel Investment Tax Credit Act

◆ **LB 282** (Pirsch) Exempt motor vehicle washing and waxing from sales taxation

**LB 283** (Conrad) Eliminate the Limited Liability Company Act

◆ **LB 284** (Conrad) Change provisions of the Political Subdivisions Tort Claims Act relating to limits on actions and amounts recoverable

**LB 285** (Conrad) Change authorized transfers to the Nebraska Health Care Cash Fund

◆ **LB 286** (Conrad) Provide for Cash Reserve

Fund transfers for affordable housing, homeless shelter assistance, and legal aid

◆ **LB 287** (Carlson) Change rabies vaccination provisions

◆ **LB 288** (Carlson) Change provisions of the Commercial Dog and Cat Operator Inspection Act

**LB 289** (Lathrop) Change provisions relating to duration of real estate improvement contract liens

**LB 290** (Pirsch) Change provisions relating to the Residential Mortgage Licensing Act

**LB 291** (Nordquist) Change medical payment provisions of the Nebraska Workers' Compensation Act

◆ **LB 292** (Karpisek) Change population restrictions for conducting elections by mail

◆ **LB 293** (Kintner) Prohibit disclosure of any applicant or permitholder information regarding firearms registration, possession, sale, or use as prescribed

◆ **LB 294** (Seiler) Change provisions relating to use of public resources by public officials and public employees

◆ **LB 295** (Sullivan) Redefine a term under the Local Option Municipal Economic Development Act

**LB 296** (Hadley) Change provisions of the educational savings plan relating to income tax reductions and participation agreements

◆ **LB 297** (Bolz) Change mental injuries and mental illness compensation under the Nebraska Workers' Compensation Act

**LR 22** (Campbell) Provide the Health and Human Services Committee and the Banking, Commerce and Insurance Committee be designated to convene a Partnership Towards Nebraska's Health Care System Transformation

# 2013 legislative bills

**Introduction date: Jan. 17, 2013**

- ◆ **LB 298** (McCoy) Change provisions relating to controlled substances schedules
- ◆ **LB 299** (Seiler) Change political subdivision election provisions
- LB 300** (Krist) Provide licensure requirements for health care facilities and require Department of Health and Human Services to provide abortion information
- LB 301** (Carlson) Change provisions relating to transfer of property between school districts
- ◆ **LB 302** (Wallman) Change total disability income benefits under the Nebraska Workers' Compensation Act
- LB 303** (Wallman) Change registration requirements for land surveyors
- ◆ **LB 304** (Wallman) Change requirements relating to gasohol and provide requirements for use of E15 by the Department of Roads
- LB 305** (Nordquist) Change provisions relating to State Patrol retirement
- LB 306** (Nordquist) Change judges' contribution for retirement as prescribed
- ◆ **LB 307** (Nelson) Change provisions of the Nebraska Workers' Compensation Act
- ◆ **LB 308** (Schumacher) Change income tax calculations relating to the federal alternative minimum tax
- LB 309** (Bolz) Adopt the Department of Health and Human Services Delivery Improvement and Efficiency Act
- ◆ **LB 310** (Bolz) Clarify compensation for shoulder injuries under the Nebraska Workers' Compensation Act
- ◆ **LB 311** (Scheer) Change filing requirements for official bonds and oaths
- ◆ **LB 312** (Scheer) Designate certain acts as unfair insurance trade practices
- ◆ **LB 313** (Christensen) Change provisions relating to incarceration work camps
- ◆ **LB 314** (Christensen) Adopt the Escort Services Accountability and Permit Act
- ◆ **LB 315** (Christensen) Redefine massage therapy and change licensure requirements
- ◆ **LB 316** (Harr) Redefine automobile liability policy
- ◆ **LB 317** (Price) Change a duty of county assessors relating to real property valuation
- ◆ **LB 318** (McGill) Change duties of law enforcement officers and agencies relating to the taking and distribution of fingerprints
- (League) **LB 319** (McGill) Change certain permitholder penalty provisions under the Concealed Handgun Permit Act
- ◆ **LB 320** (McGill) Change temporary custody without a warrant provisions of the Nebraska Juvenile Code
- ◆ **LB 321** (Crawford) Change a provision relating to disability retirement payments
- LB 322** (Karpisek) Require the Department of Natural Resources to conduct an environmental study relating to the Blue River
- LB 323** (Haar) Create the School Finance Review Committee
- ◆ **LB 324** (Lautenbaugh) Change provisions of the Nebraska Workers' Compensation Act
- ◆ **LB 325** (Brasch) Change provisions relating to approval of natural resources district boundary changes
- LB 326** (Howard) Change provisions of Pharmacy Practice Act and Automated Medication Systems Act
- ◆ **LB 327** (Pirsch) Change income tax rates
- ◆ **LB 328** (Pirsch) Change corporate income tax rates

# 2013 legislative bills

◆ **LB 329** (Howard) Change provisions relating to criminal offenses against animals

**LB 330** (Howard) Change eligibility provisions relating to the Supplemental Nutrition Assistance Program

**LB 331** (Harms) Change provisions relating to the Nebraska Opportunity Grant Act

**LB 332** (Harms) Change application provisions relating to the Access College Early Scholarship Program

◆ **LB 333** (Schumacher) Change the sales and use tax collection fees

**LB 334** (Nordquist) Appropriate funds for the Nebraska Opportunity Grant Program

◆ **LB 335** (Christensen) Authorize possession of firearms as prescribed

◆ **LB 336** (Carlson) Change sickness and accident insurance provisions for policies subject to the federal Patient Protection and Affordable Care Act

**LB 337** (Schumacher) Change provisions relating to the Nebraska Insurers Supervision, Rehabilitation, and Liquidation Act

**LB 338** (Gloor) Prohibit certain practices by health care professionals and health care facilities

**LB 339** (Schilz) Change fence dispute provisions

**LR 23** (Avery) Memorialize Congress to support a constitutional amendment responding to the U.S. Supreme Court decision in *Citizens United v. Federal Election Commission*

## 2013 Committee Hearings Schedule

**Tuesday, January 22, 2013**

**Agriculture**

**Room 2102 - 1:30 p.m.**

**LB 60** (Larson) Change the livestock brand inspection area boundaries

**LB 70** (Schilz) Change Nebraska Dairy Industry Development Board membership provisions

**LB 67** (Schilz) Change provisions of the Nebraska Milk Act

**Banking, Commerce and Insurance**

**Room 1507 - 1:30 p.m.**

**LB 72** (McCoy) Extend the authorization for interest-bearing trust accounts under the Nebraska Real Estate License Act

**LB 100** (Watermeier) Eliminate a notice requirement with respect to automatic teller machines

**LB 146** (Gloor) Change provisions relating to funds transfers under the Uniform Commercial Code

**LB 155** (Gloor) Change provisions relating to deposits of public funds in excess of insured or guaranteed amounts

**Transportation and Telecommunications**

**Room 1113 - 1:30 p.m.**

**LB 30** (Hadley) Change distribution of motor vehicle certificate of title fees

**LB 35** (Hadley) Adopt and update references to certain federal provisions related to motor vehicles

**Urban Affairs**

**Room 1510 - 1:30 p.m.**

**LB 87** (McGill) Change procedures for filling certain airport authority board vacancies

**LB 111** (McGill) Authorize a city of the first or second class or village to adopt a biennial budget

**LB 112** (McGill) Change powers and duties of city and village clerks and treasurers as prescribed

**LB 113** (McGill) Provide for mayors of cities of the second class to vote in certain situations

**LB 48** (Ashford) Change provisions relating to housing agencies

**LB 49** (Ashford) Change provisions relating to housing agencies

**Wednesday, January 23, 2013**

**Government, Military and Veterans Affairs**

**Room 1507 - 1:30 p.m.**

**LB 41** (Cook) Provide for permanent early voting request list and return of early voting ballots to polling places

**LB 56** (Larson) Provide for automatic nomination of certain county officers

**LB 144** (Brasch) Provide for write-in candidacy by defeated candidate

**LR 12CA** (Harms) Constitutional amendment to authorize a county manager form of county government

**Health and Human Services**

**Room 1510 - 1:30 p.m.**

**LB 7** (Krist) Change and eliminate provisions relating to signatures and seals under the Engineers and Architects Regulation Act

**LB 13** (Krist) Require radon resistant construction and radon mitigation statements for residential construction and create a building codes task force

**LB 139** (Krist) Change vital statistics information relating to annulment and dissolution of marriage

## 2013 Committee Hearings Schedule

### Judiciary

#### Room 1113 - 1:30 p.m.

- LB 128** (Coash) Create the offense of disarming a peace officer
- LB 148** (Ashford) Include ammunition in certain offenses involving firearms
- LB 50** (Ashford) Prohibit unreasonable placement of a firearm where a minor may unlawfully possess it
- LB 142** (Lathrop) Provide that probation records are not subject to disclosure as prescribed
- LB 99** (Mello) Change provisions relating to racial profiling information reviews

### Natural Resources

#### Room 1525 - 1:30 p.m.

- LB 102** (Watermeier) Change requirements for certain water permit applications
- LB 16** (Christensen) Change provisions relating to title to Champion Mill State Historical Park

### Revenue

#### Room 1524 - 1:30 p.m.

- LB 24** (Hadley) Update references to the Internal Revenue Code
- LB 33** (Hadley) Change and eliminate certain revenue laws and authorize agreements relating to tax collection
- LB 34** (Hadley) Change provisions of the Nebraska Advantage Act

**Thursday, January 24, 2013**

### Government, Military and Veterans Affairs

#### Room 1507 - 2:00 p.m.

- LB 78** (Avery) Eliminate a task force, an authority, a board, committees, a commission, and a council
- LB 125** (Lautenbaugh) Change provisions relating to boards of education of Class V school districts

### Health and Human Services

#### 1510 - 1:30 p.m.

- LB 225** (Smith) Adopt the Newborn Critical Congenital Heart Disease Screening Act
- LB 23** (Hadley) Change allocations of the ICF/MR Reimbursement Protection Fund
- LB 156** (Watermeier) Eliminate a report made to the Department of Health and Human Services by counties utilizing a community service program

### Judiciary

#### Room 1113 - 1:30 p.m.

- LB 3** (Krist) Change filing provisions relating to nonconsensual liens
- LB 12** (Krist) Change product liability action statute of limitations
- LB 37** (Wightman) Change provisions relating to powers of personal representative with respect to a decedent's Internet sites
- LB 45** (Ashford) Change judge eligibility requirements for the Court of Appeals
- LB 51** (Ashford) Change provisions relating to publication of court opinions

### Natural Resources

#### Room 1525 - 1:30 p.m.

- LB 91** (Haar) Change provisions regarding geologists
- LB 203** (Scheer) Change provisions relating to solid waste under the Environmental Protection Act

### Revenue

#### Room 1524 - 1:30 p.m.

- LB 25** (Hadley) Change provisions relating to the cigarette tax and the tobacco products tax
- LB 26** (Hadley) Change the commission allowed to stamping agents for the cigarette tax

## 2013 Committee Hearings Schedule

Friday, January 25, 2013

**Government, Military and Veterans Affairs  
Room 1507 - 1:30 p.m.**

**LB 140** (Krist) Change provisions of the Airport Zoning Act

**LB 40** (Harms) Update references to Government Auditing Standards

**LB 79** (Avery) Change political accountability and disclosure provisions and repeal campaign finance laws

**LB 137** (Avery) Establish state fleet card programs

**Health and Human Services  
Room 1510 - 1:30 p.m.**

**LB 132** (Nordquist) Adopt the Skin Cancer Prevention Act

**LB 54** (Wightman) Change display of credential and advertisement provisions under the Uniform Credentialing Act

**LB 42** (Cook) Change credentialing requirements for administrators of facilities for persons with head injuries

**Judiciary**

**Room 1113 - 1:30 p.m.**

**LB 89** (Haar) Provide immunity from liability for providing shelter during a weather event

**LB 120** (Lautenbaugh) Change provisions of the Uniform Residential Landlord and Tenant Act

**LB 123** (Lautenbaugh) Change distribution of indigent defense fees

**LB 52** (Christensen) Change employment provisions for persons committed to the Department of

Correctional Services

**LB 151** (Seiler) Provide a hearsay exception for certain documents and data kept in the regular course of business

**Revenue**

**Room 1524 - 1:30 p.m.**

**LB 28** (Hadley) Change a late filing penalty relating to personal property tax

**LB 29** (Hadley) Provide a duty for county treasurers relating to recording tax assessments and collections

**LB 36** (Wightman) Change an exemption to the documentary stamp tax

**TENTATIVE SCHEDULE**

Monday, January 28, 2013

**Banking, Commerce and Insurance  
Room 1507 - 1:30 p.m.**

**LB 213** (Gloor) Change provisions relating to financial institutions

**LB 214** (Gloor) Change provisions relating to securities and seller-assisted marketing plans

**LB 279** (Pirsch) Change provisions relating to loan brokers, delayed deposit services, and installment loans

**LB 290** (Pirsch) Change provisions relating to the Residential Mortgage Licensing Act

**Business and Labor  
2102 - 1:30 p.m.**

**LB 58** (Larson) Adopt the Workplace Privacy Act

**LB 297** Bolz Change mental injuries and mental illness compensation under the Nebraska Workers' Compensation Act

**LB 21** (Lathrop) Eliminate a Nebraska Workers' Compensation Act sunset provision for certain benefits

**LB 141** (Lathrop) Change court procedures for the Nebraska Workers' Compensation Court

**LB 291** (Nordquist) Change medical payment provisions of the Nebraska Workers' Compensation Act

## 2013 Committee Hearings Schedule

### Education

#### Room 1525 - 1:30 p.m.

- LB 121** (Lautenbaugh) Provide for waiver of a Nebraska certificate to administer
- LB 135** (Avery) Change membership provisions relating to Community College Boards of Governors
- LB 211** (Adams) Change and eliminate provisions relating to statewide coordination of community college boards
- LB 252** (Adams) Correct and change subdivision references and references to governmental entities related to postsecondary education

### Executive Board

#### Room 2102 - 12:00 p.m.

- LB 39** (Harms) Change and eliminate references to the Legislative Performance Audit Section
- LB 149** (Pirsch) Provide for biennial reviews of state agency programs and services
- LR 20** (Lathrop) Provide for continuation of the Developmental Disabilities Special Investigative Committee

### General Affairs

#### Room 1510 - 1:30 p.m.

- LB 173** (Coash) Change provisions relating to documentary proof of age under the Nebraska Liquor Control Act
- LB 230** (Karpisek) Change shipping license provisions under the Nebraska Liquor Control Act
- LB 259** (Karpisek) Exempt keno writers from licensure under the Nebraska County and City Lottery Act
- LB 273** (Karpisek) Change keno time limits

### Transportation and Telecommunications

#### Room 1113 - 1:30 p.m.

- Appointment** Lahm, Rhonda - Department of Motor Vehicles
- LB 32** (Hadley) Change provisions relating to historical vehicle license plates
- LB 207** (McCoy) Change motor vehicle registration provisions
- LB 249** (Dubas) Change motor vehicle provisions relating to farm vehicles and drivers transporting agricultural commodities or farm supplies
- LB 250** (Dubas) Change motor vehicle provisions relating to issuance of trip permits

Tuesday, January 29, 2013

### Agriculture

#### Room 2102 - 1:30 p.m.

- LB 15** (Krist) Change Pesticide Act provisions
- LB 68** (Schilz) Change provisions of the Plant Protection and Plant Pest Act
- LB 69** (Schilz) Change provisions of the Pesticide Act

*If auxiliary aids or reasonable accommodations are needed for attendance at a hearing, please call the office of the Clerk of the Legislature, (402) 471-2271, or for persons with hearing impairments, please call the Nebraska Relay System, (800) 833-7352 TTY or (800) 833-0920 Voice. Advance notice of ten business days is needed when requesting an interpreter.*

# LEGISLATIVE BULLETIN

## LEAGUE OF NEBRASKA MUNICIPALITIES

103rd Legislature, First Session

Jan. 25, 2013 - Bulletin 3



### ITEMS OF INTEREST TO MUNICIPALITIES

- **LB 474 (Krist) and LB 488 (Revenue Committee):** These two bills would restrict municipalities on the imposition of occupation taxes; the bill introduced by the Revenue Committee is less restrictive than Sen. Krist's proposal. Notwithstanding, **PLEASE send the League office an updated copy of your occupation taxes.** Attached is a copy of what Mike Morgan from the City of Kearney sent us, which is a good format for providing this information. **Please make this a high priority since the hearings will be scheduled sooner than later. Thank you.**
- **LB 21 (Lathrop):** On Jan. 28, the Business and Labor Committee will hold a hearing on LB 21 to eliminate a Workers' Compensation Act sunset provision for mental injury benefits for first responders. This law is referred to as the "mental-mental law." The law provides workers' compensation coverage for first responders with mental injuries or mental illness unaccompanied by physical injury. The provisions of the law are scheduled to "sunset" or terminate on June 30, 2014. The intent of the sunset was to give the Legislature a chance to review the legislation to see its fiscal impact. LB 21 would continue the coverage permanently. **Please let the League know as soon as possible if you have had any mental injury workers compensation claims filed by first responders; please let us know if any of your first responders have discussed filing claims with you or others.**  
Another bill will be heard the same day, **LB 297**, which would extend Workers' Compensation mental injury and mental illness benefits to coroners.
- **Bill introduction ended Jan. 23; 655 bills introduced**

NOT ALL ITEMS OF INTEREST ARE INCLUDED ON THIS LIST.  
ALSO SEE THE REMAINDER OF THE LEGISLATIVE BULLETIN.

## LB 87: Urban Affairs Committee hears League bill on city airport authority vacancies

**LB 87** addresses a concern with filling a vacancy on a city airport authority in cities of the primary, first, and second class and villages. The bill was introduced by **Sen. Amanda McGill** of Lincoln on behalf of the League.

City airport authority members are elected, but a vacancy appointment is made by the mayor and confirmed by the council until the next election. **LB 87** provides that the appointment is for the whole unexpired term rather than just until the next election. Airport authority members serve six-year terms.

Some cities are having trouble filling vacancies because potential authority members do not want to

run for election shortly after being appointed. Serving the remainder of the term will make the appointment more attractive and provide stability to the authority.

**LB 87** will make a vacancy appointment to the city airport authority consistent with a vacancy appointment to the city council in cities of the first and second classes and to the city airport authority in a city of a metropolitan class. Under current law, these appointments are for the remainder of the term.

Thanks to **Sen. McGill** for introducing **LB 87**. Thanks also to **Jerry Wilcox**, Crete City Clerk/Treasurer, and **Rod Storm**, Blair City Administrator, for testifying with a **League representative** in



*Sen. Amanda McGill*

support of the bill. **Storm** testified on behalf of the city of Blair and the Nebraska Association of Airport Officials. Thanks also to **Mike Lang**, Economic Development Aide for the Mayor of the city of Lincoln, for sending a letter of support on behalf of the city.

## LB 111: Urban Affairs Panel holds hearing on League bill to allow cities, villages to file biennial budgets

Lincoln **Sen. Amanda McGill**, Urban Affairs Committee Chair, introduced **LB 111** on behalf of the League to amend the State Budget Act to authorize cities of the first and second class and villages to file biennial budgets with the State Auditor's Office and County Clerk. Under the bill, the decision to change to a biennial budget can be made by

a vote of the city council or village board.

On Jan. 22, the committee held a hearing on the bill.

Budgeting for two years rather than one will give municipalities the opportunity to do more long-range fiscal planning to stabilize expenditures and taxes. In 2000, the Legislature enacted **LB 1116** to authorize cities of the metropolitan (Omaha)

and primary (Lincoln) classes to adopt biennial budgeting if the voters authorize the change in the city charter. In 2010, the citizens of Lincoln voted to amend the city charter to allow the city council to file biennial budgets.

Thanks to Crete **Mayor Roger Foster** for testifying with a **League representative** in support of the bill.

## LB 112: Hearing held on League bill to transfer duties from city clerk to city treasurer

Lincoln **Sen. Amanda McGill**, Urban Affairs Committee Chair, introduced a bill on behalf of the League, **LB 112**, to change bond recording duties of city clerks and city treasurers.

On Jan. 22, the Urban Affairs Committee held a hearing on the bill.

LB 112 transfers duties from a city clerk to a city treasurer in cities of the first and second class and villages. The duties relate to keeping records and reporting on the outstanding bonds of the city or village.

Current law requires the clerk to keep a record of all outstanding bonds and to list the bonds issued and sold during the year in the clerk's annual report. This is infor-

mation that is generally generated by the treasurer and, therefore, it is more efficient to have the treasurer keep the records and make the report.

LB 112 simply transfers these requirements from the clerk to the treasurer.

LB 112 also expands the duties of the treasurer to require the treasurer to prepare lists of all special assessments and collect all special assessments. Current law requires the treasurer prepare only lists of paving and curbing taxes. An obsolete reference to school funds is deleted.

The provisions of LB 112 were in a bill, LB 864, in the 2012 legislative session. Although that bill was advanced by the committee to General



*Sen. Amanda McGill*

File, the Legislature adjourned before it was considered by the body.

Thanks to Sen. McGill for introducing LB 112. Thanks also to **Kay Dammas**, Bellevue City Clerk, for testifying with a **League representative** in support of the bill.

## LB 113: Urban Affairs Panel holds hearing on League bill to change when a mayor of a city of second class can vote on issue before city council

**LB 113** proposed to make changes regarding when the mayor of a city of the second class can vote on an issue before the city council.

The bill was introduced by **Sen. Amanda McGill** of Lincoln on behalf of the League.

Under current law, a mayor may vote when the council is evenly divided. LB 113 would authorize the mayor to vote when his or her vote will provide the additional vote required to create a number of votes equal to a majority of the members

elected to the council.

On Jan. 22, the Urban Affairs Committee held a hearing on LB 113. Testifying in favor of the bill were **Doug Walker**, Alma City Attorney, and a **League representative**.

Most cities of the second class have four council members. When a vote is 2-2, a mayor may vote to break the tie. However, when one member is absent or has to abstain, the vote can be 2-1. Ordinances, resolutions, contracts, and other matters require three votes to pass. Because

the council is not evenly divided, the mayor cannot vote. A 2-1 vote leaves the question in limbo.

LB 113 would allow the mayor to vote in situations where his or her vote would be the additional vote needed to equal the needed majority.

This is the current law for mayors in a city of the first class. LB 113 would make the voting authority of a mayor of a city of the second class consistent with that of the mayor of a city of the first class.

## League Bills – 2013 Legislative Session

The Executive Board of the League of Nebraska Municipalities met before the 2013 legislative session to review recommendations of the League Larger and Smaller Cities Legislative Committees. The League Executive Board directed that the following bills be introduced on behalf of the League.

**LB 87** (Sen. McGill) Changes the process for filling vacancies on the airport authority. The appointment by the mayor and confirmed by the council should be for the unexpired term rather than just until the next general election. **Urban Affairs Comm., Hearing Jan. 22, 2013.**

**LB 111** (Sen. McGill) Authorize a city of the first class to adopt a biennial budget. **Urban Affairs Comm., Hearing Jan. 22, 2013.**

**LB 112** (Sen. McGill) Change bond recording duties of city clerks and city treasurers. **Urban Affairs Comm., Hearing Jan. 22, 2013.**

**LB 113** (Sen. McGill) Gives the mayor of a city of the second class the right to vote on a city council action when his or her vote will provide the additional vote required to create a number of votes equal to a majority of the council. **Urban Affairs Comm., Hearing Jan. 22, 2013.**

**LB 319** (Sen. McGill) Change certain permitholder penalty provisions under the Concealed Handgun Permit Act to include property owned or leased by the state or any political subdivision of the state. **Judiciary Comm.**

**LB 377** (Sen. Johnson) Change provisions relating to annexation of a county road by a city or village. **Urban Affairs Comm.**

**LB 462** (Sen. Ashford) Change provisions relating

### 2013 LEGISLATIVE SESSION



to contracts for joint law enforcement services. **Judiciary Comm.**

**LB 473** (Sen. Bloomfield) Authorize certain residency restrictions near parks under the Sexual Predator Residency Restriction Act. **Judiciary Comm.**

**LB 574** (Sen. Burke Harr) Provide that certain assessments are levied and collected as special assessments. **Revenue Comm.**

**LB 510** (Sen. Scheer) Change Open Meeting Act telephone conference call provisions and authorization for videoconferencing and teleconferencing. **Government Comm.**

**LB 580** (Sen. Johnson) Change certain condemnation procedures. **Judiciary Comm.**

**LB 614** (Sen. Schumacher) Provide for withholding insurance proceeds for demolition costs. **Banking Comm.**

**LB 621** (Sen. Karpisek) Exempt certain information from disclosure under the Intergovernmental Risk Management Act. **Banking Comm.**

**LB 643** (Sen. Davis) Change certain provisions regarding nuisances in cities and villages. **Urban Affairs Comm.**

**LR 12CA: Thanks to Chris Anderson, Brett Baker for joining the League, others in support of proposed constitutional amendment sponsored by Sen. Harms to authorize option for county manager form of county government**

On Jan. 23, the Government, Military and Veterans Affairs Committee received testimony relating to **LR 12CA**. **Sen. John Harms** of Scottsbluff again introduced this proposed constitutional amendment to provide an option for a county manager form of county government. Sen. Harms provided a quick summary of how this proposed constitutional amendment developed over the years. In 1933, the Legislature passed a statute allowing any county to adopt a county manager plan. After Douglas County did so in 1933, a lawsuit was successfully filed challenging the constitutionality of the Douglas County manager plan. In 1939, the Legislature placed a proposed constitutional amendment on the ballot to amend Article IX, Section 4 to allow a county the option of having a county manager plan. In 1940, the proposed constitutional amendment failed and the voters rejected the proposal again statewide in 1944. Former state Sen. Joyce Hillman, who represented Scotts Bluff County before Sen. Harms, also tried to place a similar constitutional amendment on the ballot. Unfortunately, Sen. Hillman's efforts were unsuccessful. Sen. Harms said LR 12CA is not self-executing; it would simply allow the Legislature the authority to pass enabling legislation to allow counties the option of having a county manager plan.

Thanks to **Chris Anderson**, City Administrator of Central City and member of the ICMA Board of Directors, who testified in strong support of LR 12CA. Chris stated that about 27 percent of counties in the United States operate under some type of county manager plan. Anderson emphasized that a city or county manager provides management expertise in a nonpartisan and professional manner. He outlined how professional managers and administrators implement the policies of the governing bodies they serve.

Thanks also to **Brett Baker**, Seward City Administrator, NCMA President and League Executive Board Member, for his testimony in favor of LR 12CA. Baker also underscored the importance of professional management and said professional managers try to

**2013**  
**LEGISLATIVE**  
**SESSION**



build fairness and consensus to implement the policy choices of the governing body. Both Baker and Anderson discussed the ethical commitment of professional managers.

A **League representative** testified in strong support of LR 12CA emphasizing that professional management for municipalities occurs in two forms: 1) with mayors and councils appointing city administrators and providing their responsibilities by ordinance or 2) with citizens electing a city manager form of government as provided in Chapter 19, Article 6. The League representative said that many city administrators have the same, if not more, authority granted to them by ordinance as city managers have outlined in Chapter 19, Article 6

There are 10 cities with a city manager form of government. There are eight cities of the first class: Alliance, Chadron, Kearney, Lexington, McCook, Ogallala, Scottsbluff and Sidney. There are two cities of the second class with a city manager form of government: Gordon and Valentine. In addition, about 90 other municipalities have city administrators, many of whom have additional duties. For example, many city administrators also serve as clerk/treasurer. The League representative provided an historic perspective on how and why this issue has developed over the years. If the Legislature places this issue on the ballot and it passes in November 2014, the Legislature could then pass enabling legislation to authorize counties the option of having a county manager form of government tailored

*Continued on page 6*

**LR 12CA: Thanks to Chris Anderson, Brett Baker for joining the League, others in support of proposed constitutional amendment sponsored by Sen. Harms to authorize option for county manager form of county government**

*Continued from page 5*

to the needs of the respective county.

**Linda Duckworth**, representing the League of Women Voters of Nebraska (LWV), also testified in support of LR 12CA. She stated that LWV studied the issues in the 1970s, recommending that county government needed to have major structural changes. LWV reaffirmed its position in 1991, stating that each county should be able to choose its own structure and a county manager plan should be one option for consideration.

**Wayne Stott**, Scotts Bluff County Surveyor, supported LR 12CA. Stott is an elected official as well as an appointed official. He said “there is a human tendency for turf preservation within county government,” which sometimes inhibits cooperation and limits progress, especially in the area of Information Technology. He also said many county offices do not require any training or qualifications, which is problematic.

**Dr. John Bartle**, UNO Professor, testified in support of LR 12CA, in his individual capacity, not on behalf of the university. He outlined many advantages of professional management and discussed some of his recent research on related issues.

**Mark Masterton**, current Chair of the Scotts Bluff County Commission, provided compelling testimony to the committee in favor of LR 12CA. He was first elected in 1983 and now, as chair of the board, he has been involved in numerous issues that underscore the need for professional county management. For example, three years ago, the Scotts Bluff County Assessor took the Scotts Bluff County Board to the Tax Equalization Review Commission (TERC). Obviously, the county board was against the county assessor doing so. It cost the county \$17,000 in legal fees to defend itself. The county assessor spent another \$19,000 on the effort. Taxpayers paid for both sides of the controversy. Masterton stated that there are 11 officials in Scotts Bluff County in charge of their own “kingdoms” who do not have to comply with requests from the county

**2013  
LEGISLATIVE  
SESSION**



board. The county board does have some control over their respective budgets. Masterton strongly advocated that the Legislature let local taxpayers decide whether they want professional county management.

**There was no opposition testimony.** However, Larry Dix, Executive Director of the Nebraska Association of County Officials (NACO), testified in a neutral position since his executive board had not yet met. It should be noted that NACO has consistently opposed this legislation in the past.

Tom Cavanaugh, Douglas County Clerk for 27 years, testified in a neutral capacity stating that he is in favor of changing county government. He supports LR 12CA with the provision that the position of county manager in Douglas County should be elected, not appointed. He believes the county manager in Douglas County should be elected to provide added accountability to the citizens. He emphasized that he is the only county clerk who also is required to be the county comptroller. The Legislature made this requirement because of allegations of corruption in Douglas County years ago.

Sen. Harms, in his closing, said he would be happy to work with the committee to advance this important proposal. **Sen. Bill Avery** of Lincoln, Chair of the Government Committee, said he had three letters in support of LR 12CA, including one from the **Mayor of Lexington**. Sen. Avery told the committee that he received two letters in opposition to the measure from county officials.

# 2013 legislative bills

One-line descriptions of bills are provided by the Clerk of the Legislature's Office.

◆ = Bills monitored by the League  
(League) = League-backed bills

## Introduction date: Jan. 18, 2013

◆ **LB 340** (Natural Resources Committee) Change a hearing requirement related to the Nebraska Power Review Board

◆ **LB 341** (Wightman) Change tax sale procedures

**LB 342** (Coash) Change right to counsel provisions under the Nebraska Juvenile Code

**LB 343** (Coash) Change terminology related to mental retardation

**LB 344** (Sullivan) Change moratorium exceptions for long-term care beds

**LB 345** (Wightman) Change transfer on death deed requirements and filings

◆ **LB 346** (Kolowski) Authorize school districts to levy a tax and exceed budget authority for school security measures

◆ **LB 347** (Gloor) Provide for a moratorium on issuance of licenses under the Health Care Facility Licensure Act

◆ **LB 348** (Harr) Change provisions relating to the assessment of certain rent-restricted housing projects

**LB 349** (Murante) Change ballot status and write-in provisions for presidential and vice-presidential candidates

◆ **LB 350** (Murante) Add members to the Nebraska Police Standards Advisory Council

◆ **LB 351** (Harms) Require cognitive tests for persons eighty years of age or older obtaining motor vehicle operator's licenses

◆ **LB 352** (Christensen) Provide signage requirements and duties for the Nebraska State

Patrol under the Concealed Handgun Permit Act

◆ **LB 353** (Christensen) Restrict rule and regulation authority of natural resources districts

**LB 354** (Larson) Adopt the Nebraska Corn Promotion Act

◆ **LB 355** (Larson) Change the age of majority and certain age requirements

**LB 356** (Karpisek) Prohibit participation in extracurricular and co-curricular activities as prescribed

**LB 357** (Haar) Change a budget limitation exemption under the Tax Equity and Educational Opportunities Support Act

◆ **LB 358** (Dubas) Redefine excavation for purposes of the One-Call Notification System Act

**LB 359** (Cook) Change eligibility redeterminations relating to a child care subsidy

◆ **LB 360** (Karpisek) Change court fees, sheriff's fees, identification inspection fees, and handgun certificate fees

**LB 361** (Howard) Name the Child and Maternal Death Review Act and change review procedures

**LB 362** (Avery) Change state park entry permit provisions and provide for a motor vehicle registration fee

◆ **LB 363** (Avery) Change provisions relating to access to public records

◆ **LB 364** (Avery) Permit government bodies to set limits on certain contracts

**LB 365** (Avery) Require instruction in certain emergency procedures as a prerequisite to high school graduation

**LB 366** (Cook) Adopt the Remedial Adult Education Innovation Act

# 2013 legislative bills

**LB 367** (Cook) Adopt the Twenty-First Century Developmental Education Act

**LB 368** (Crawford) Create a subsidized employment pilot program within the Department of Health and Human Services

**LB 369** (Lathrop) Require licensed service providers for services to probationers and parolees as prescribed

◆ **LB 370** (Lathrop) Create the County Property Tax Assistance Program and the Municipal Property Tax Assistance Program

◆ **LB 371** (Mello) Adopt the Transparency in Government Procurement Act

◆ **LB 372** (Mello) Adopt the Buy Nebraska Act and eliminate provisions relating to resident bidder preferences

◆ **LB 373** (Mello) Change Nebraska Construction Prompt Pay Act provisions

**LB 374** (Nelson) Provide for a delinquent child support payment lien on an appearance bond as prescribed

**LB 375** (Lathrop) Appropriate funds to the Department of Health and Human Services to be used for services for persons with developmental disabilities

◆ **LB 376** (Johnson) Appropriate funds to the Department of Economic Development

**(League) LB 377** (Johnson) Change provisions relating to annexation of a county road by a city or village

◆ **LB 378** (Smith) Eliminate fees for the issuance of certain license plates

◆ **LB 379** (Nelson) Change furlough and reduction of sentence provisions as prescribed

**LB 380** (Howard) Provide for adoption by two adult persons jointly

◆ **LB 381** (Janssen) Require photographic identification to vote

**LB 382** (Janssen) Change presidential elector selection and voting requirements

◆ **LB 383** (Janssen) Provide for Nebraska Armed Forces Pride Plates

◆ **LB 384** (Nordquist) Adopt the Nebraska Exchange Transparency Act

**LB 385** (Nordquist) Prohibit certain bases for discrimination relating to child placement

◆ **LB 386** (Christensen) Require notice of road maintenance by counties as prescribed

◆ **LB 387** (Christensen) Eliminate provisions relating to constructing drainage facilities and taking other control measures on public roads

◆ **LB 388** (Natural Resources Committee) Change provisions relating to public power and provide for construction of certain transmission lines

◆ **LB 389** (Bolz) Provide an income tax credit for adoption and guardianship costs

◆ **LB 390** (Christensen) Change provisions relating to Governor's powers regarding restrictions on firearms and ammunition under the Emergency Management Act

◆ **LB 391** (Davis) Change water law provisions relating to water storage

◆ **LB 392** (Lathrop) Eliminate certain firearms provisions no longer authorized by federal law

◆ **LB 393** (Bloomfield) Change helmet and eye protection provisions regarding motorcycles

◆ **LB 394** (Conrad) Authorize use of Affordable Housing Trust Fund for vocational training

**LB 395** (Conrad) Redefine the term "school-based health center" for purposes of the Medical Assistance Act

◆ **LB 396** (Conrad) Change Nebraska Workers' Compensation Court powers

**LB 397** (Conrad) Require insurance coverage for screening for amino acid-based formulas

◆ **LB 398** (Brasch) Change provisions and penalties relating to certain excessively loaded vehicles

◆ **LB 399** (Lautenbaugh) Permit members of

# 2013 legislative bills

certain organizations to use flashing amber lights on motor vehicles

**LB 400** (Lautenbaugh) Appropriate funds for aid to community colleges

**LB 401** (Lautenbaugh) Adopt the School Purchasing Act

**(League) LR 29CA** (Adams) Constitutional amendment to change provisions relating to redevelopment projects

**LR 31** (Campbell) Provide the Executive Board appoint the Children's Behavioral Health Oversight Committee as a special committee

## Introduction date: Jan. 22, 2013

◆ **LB 402** (Mello) Change power purchase agreement provisions relating to rural community-based energy development

◆ **LB 403** (Seiler) Prohibit retail sale of novelty lighters

◆ **LB 404** (McGill) Change State Natural Gas Regulation Act provisions relating to infrastructure system replacement cost recovery charges

◆ **LB 405** (McCoy) Eliminate certain sales tax exemptions, corporate and individual income taxes, and the franchise tax and change other tax provisions

◆ **LB 406** (McCoy) Change tax provisions

**LB 407** (Sullivan) Change calculation provisions under the Tax Equity and Educational Opportunities Support Act

**LB 408** (Sullivan) Change dates and provisions relating to certification and distribution of state aid

**LB 409** (Sullivan) Change distribution provisions for core services and educational technology funds

**LB 410** (Sullivan) Change and eliminate provisions relating to education

◆ **LB 411** (Nordquist) Change a renewable energy tax credit

◆ **LB 412** (Schumacher) Adopt the Freedom from Unwarranted Surveillance Act

◆ **LB 413** (Schumacher) Change license violation provisions under the Nebraska Liquor Control Act

◆ **LB 414** (Schumacher) Change funding for the Municipal Equalization Fund

**LB 415** (Seiler) Change provisions relating to financial institutions and attachment and garnishment

**LB 416** (Kolowski) Change teacher education allowance provisions relative to the state aid formula

◆ **LB 417** (Kolowski) Provide for guidelines for election workers

◆ **LB 418** (Kolowski) Change powers and duties of election commissioners, chief deputy election commissioners, and county boards

◆ **LB 419** (Hadley) Change provisions relating to the nameplate capacity tax

◆ **LB 420** (McGill) Provide authorization for disposition of human remains based on military documents

◆ **LB 421** (McGill) Provide powers and duties for professional boards regarding credentialing veterans

◆ **LB 422** (McGill) Provide duties for credentialing boards and temporary practice permits for military spouses

◆ **LB 423** (Agriculture Committee) Change seizure provisions of the Livestock Animal Welfare Act

◆ **LB 424** (Coash) State intent to appropriate funds to the Nebraska State Patrol Internet Crimes Against Children Unit

◆ **LB 425** (Campbell) State intent to appropriate funds for intervention services for at-risk children and youth

**LB 426** (Howard) Change provisions relating to fraternal benefit societies

# 2013 legislative bills

- ◆ **LB 427** (Howard) Adopt the Carbon Monoxide Safety Act
- LB 428** (Haar) Change permitted practice provisions for certified nurse midwives
- ◆ **LB 429** (Crawford) Require disclosure of state contracts
- LB 430** (Crawford) Change asset limitation for the aid to dependent children program, child care subsidy, and the Welfare Reform Act
- ◆ **LB 431** (Karpisek) Change definition of food establishment under the Nebraska Pure Food Act
- LB 432** (Price) Appropriate funds for the Interstate Compact on Educational Opportunity for Military Children
- ◆ **LB 433** (Price) Require a report and change administration procedures for ballots at hospitals and nursing homes
- ◆ **LB 434** (Price) Provide for emergency management registries for persons with special needs
- LB 435** (Hansen) Provide for out-of-state brand permits under the Livestock Brand Act
- LB 436** (Hansen) Redefine franchisee under the Franchise Practices Act
- ◆ **LB 437** (Hansen) Transfer administration of mechanical safety inspection programs to the State Fire Marshal
- LB 438** (Adams) Provide for priority schools, operating councils, and community schools
- ◆ **LB 439** (Gloor) Change cigarette and tobacco tax provisions
- ◆ **LB 440** (Gloor) Adopt the Volunteer Emergency Responders Incentive Act and provide an income tax credit
- ◆ **LB 441** (Seiler) Change provisions relating to control of dead human remains
- LB 442** (Schumacher) Change provisions relating to homeowners' associations and the Nebraska Condominium Act
- ◆ **LB 443** (Cook) Adopt the Children's Residential Facilities and Placing Licensure Act
- ◆ **LB 444** (Krist) Require certification and presence of authorized personnel by retail liquor licensees
- ◆ **LB 445** (Karpisek) Provide funding to the Department of Motor Vehicles to purchase a vehicle titling and registration computer system
- ◆ **LB 446** (Avery) Define the term flood damage for purposes of the Motor Vehicle Certificate of Title Act
- ◆ **LB 447** (Avery) Provide for sales tax on soft drinks, change the distribution of sales tax proceeds, and provide funding for projects to help children
- ◆ **LB 448** (Avery) Prohibit contributions by lobbyists to candidates or members of the Legislature during legislative session
- ◆ **LB 449** (Avery) Redefine high elective office for restrictions on multiple office holding
- LB 450** (Avery) Change political party convention and caucus provisions
- ◆ **LB 451** (Janssen) Prohibit federal restrictions on firearms, magazines, and firearm accessories as prescribed
- LB 452** (Conrad) Require a Medicaid waiver to provide coverage for family planning services
- ◆ **LB 453** (Karpisek) Change provisions relating to motor vehicle headlights
- ◆ **LB 454** (Haar) Adopt the Electronics Extended Producer Responsibility and Job Creation Act
- ◆ **LB 455** (Lautenbaugh) Provide procedures for termination of a lease based upon clear and present danger
- ◆ **LB 456** (Lautenbaugh) Provide for removal of containers of draft beer from licensed premises as prescribed

# 2013 legislative bills

- ◆ **LB 457** (Krist) Change provisions relating to deductions for net operating losses and capital losses
- LB 458** (Krist) Require general acute hospitals to offer tetanus-diphtheria-pertussis vaccinations as prescribed
- LB 459** (Krist) Require certain health care facilities to offer onsite vaccination services
- LB 460** (Krist) Require a booster meningococcal conjugate vaccine for students as prescribed
- ◆ **LB 461** (Karpisek) Provide liability limitation for bucking bull activities
- (League) **LB 462** (Ashford) Change provisions relating to contracts for joint law enforcement services
- LB 463** (Ashford) Change the number of separate juvenile court judges
- LB 464** (Ashford) Change court jurisdiction over juveniles and indictment procedures
- LB 465** (Lautenbaugh) Adopt the College Choice Grant Program
- LB 466** (Avery) Redefine a term under the Postsecondary Education Act
- LB 467** (Avery) Provide for interstate reciprocity agreements under the Postsecondary Education Act
- ◆ **LB 468** (Scheer) Allow an income tax deduction for tuition payments
- LB 469** (Scheer) Change an exemption to school budget lid relating to payments for a voluntary termination
- LB 470** (Scheer) Adopt the Superintendent Pay Transparency Act
- LB 471** (Coash) Change provisions relating to juvenile commitment evaluations
- ◆ **LB 472** (Karpisek) Prohibit flying lanterns
- (League) **LB 473** (Bloomfield) Authorize certain residency restrictions near parks under the Sexual Predator Residency Restriction Act
- ◆ **LB 474** (Krist) Change provisions relating to occupation taxes
- ◆ **LB 475** (Carlson) Change the Angel Investment Tax Credit Act and the Business Innovation Act
- ◆ **LB 476** (Carlson) Change provisions relating to grants for internships
- ◆ **LB 477** (Carlson) Change sunset for the Riparian Vegetation Management Task Force
- LB 478** (Smith) Provide requirements for awards under the Access College Early Scholarship Program Act
- ◆ **LB 479** (Lathrop) Prohibit policy and contract terms relating to contractual rights and insurance proceeds
- LB 480** (Lathrop) Adopt the Nebraska Career Technical Education Grant Program Act
- LB 481** (Lathrop) Create the Career Education Task Force
- ◆ **LB 482** (Kintner) Prohibit the state and political subdivisions from adopting certain policy recommendations
- ◆ **LB 483** (Bolz) Provide for a reentry planning program in adult correctional facilities
- LB 484** (Karpisek) Change dental hygienist training and authorized functions
- ◆ **LB 485** (Conrad) Prohibit discrimination based upon sexual orientation as prescribed
- LB 486** (Dubas) Appropriate funds to the Legislative Council to pay dues under the Midwest Interstate Passenger Rail Compact
- ◆ **LR 34CA** (Schumacher) Constitutional amendment authorizing gaming and directing use of the proceeds

# 2013 legislative bills

**Introduction date: Jan. 23, 2013**

**LB 487** (Wightman) Change health care certificate of need provisions

◆ **LB 488** (Revenue Committee) Change provisions relating to municipal occupation taxes

◆ **LB 489** (Revenue Committee) Change the sales tax rate

◆ **LB 490** (Revenue Committee) Change income tax rates

**LB 491** (Cook) Change calculation of target level of funds under the Nebraska Opportunity Grant Act

◆ **LB 492** (Cook) Appropriate funds to carry out the Nebraska Youth Conservation Program

**LB 493** (Davis) Authorize transfer of portions of the Cowboy Trail

**LB 494** (Davis) Change number of districts and members of Game and Parks Commission

**LB 495** (Sullivan) Change provisions relating to the Education Innovation Fund and early childhood grant reporting

**LB 496** (Sullivan) Change provisions relating to school reorganization incentive payments

**LB 497** (Sullivan) Change distribution and provide for a study of the Education Innovation Fund

**LB 498** (Brasch) Provide for declaratory judgment and injunctive relief against foreign defamation judgments

◆ **LB 499** (Brasch) Change powers and duties of Game and Parks Commission

◆ **LB 500** (Brasch) Change school bus operation provisions

◆ **LB 501** (Hadley) Redefine a term in the Nebraska Advantage Act

◆ **LB 502** (Hadley) Change a sales tax exemption for health clinics

◆ **LB 503** (Coash) Rename the Child Protection Act and provide for alternative response to a report of child abuse or neglect

◆ **LB 504** (Coash) Change Commission on Indian Affairs state assistance for political subdivisions provisions

**LB 505** (Coash) Provide requirement for insurance coverage of autism spectrum disorders

**LB 506** (Bolz) Change elementary class size allowance in the state aid formula

◆ **LB 507** (Campbell) Adopt the Step Up to Quality Child Care Act

**LB 508** (Campbell) Change provisions relating to the aid to dependent children program

**LB 509** (Murante) Change election of learning community coordinating council

(League) **LB 510** (Scheer) Change Open Meeting Act telephone conference call provisions and authorization for videoconferencing and teleconferencing

**LB 511** (Scheer) Change allocation provisions relating to the Education Innovation Fund

**LB 512** (Scheer) Change provisions relating to academic content standards and statewide assessment and reporting

◆ **LB 513** (Carlson) Change notice provisions under the Nebraska Ground Water Management and Protection Act

◆ **LB 514** (Carlson) Provide for new funding mechanisms under the Wastewater Treatment Facilities Construction Assistance Act

**LB 515** (Carlson) Change provisions relating to irrigation district elections

◆ **LB 516** (Carlson) Adopt the Nebraska Water Legacy Act

◆ **LB 517** (Carlson) Create the Water Sustainability Project Task Force

# 2013 legislative bills

**LB 518** (Janssen) Change certain eligibility provisions of the medical assistance program

**LB 519** (Krist) Appropriate funds for improvements at the Nebraska History Museum

◆ **LB 520** (Christensen) Allow land surveyors to enter upon public or private lands or waters as prescribed

◆ **LB 521** (Christensen) Require cities and villages and other public bodies that maintain web sites to publish ordinances and other information as prescribed

◆ **LB 522** (Christensen) Provide state financial assistance to irrigation districts to compensate water appropriators

**LB 523** (Christensen) Provide requirements for copayments, coinsurance, and deductibles relating to certain services

**LB 524** (Christensen) Adopt the Pharmacy Audit Integrity Act

◆ **LB 525** (Haar) Change deadlines under the Election Act

**LB 526** (Howard) Change optometry licensure and certification to perform minor surgery and use pharmaceutical agents

**LB 527** (Howard) Change optometry licensure and certification to use pharmaceutical agents

**LB 528** (Howard) Provide for partner treatment relating to sexually transmitted diseases

◆ **LB 529** (Dubas) Change requirements for approval of redevelopment plans under the Community Development Law

**LB 530** (Dubas) Add, change, and eliminate provisions relating to foster care reimbursements

◆ **LB 531** (Conrad) Change distribution of sales and use tax revenue and repeal the Build Nebraska Act

◆ **LB 532** (Conrad) Change income tax rates

◆ **LB 533** (Avery) Require oil and gas pipeline eminent domain condemnors to provide notice to property owners

◆ **LB 534** (Avery) Change provisions relating to the Auditor of Public Accounts and the Legislative Performance Audit Section

**LB 535** (Lathrop) Adopt Prescription Monitoring Program Act and repeal prescription monitoring provisions

◆ **LB 536** (Business and Labor Committee) Approve claims against the state

◆ **LB 537** (Business and Labor Committee) Deny claims against the state

◆ **LB 538** (Chambers) Change provisions relating to revocation and suspension of law enforcement training certificates or diplomas

**LB 539** (Chambers) Prohibit requiring teaching experience for superintendents

**LB 540** (Chambers) Prohibit rules and regulations requiring teachers to lead pledge of allegiance

◆ **LB 541** (Chambers) Prohibit arbitration of claims involving disciplinary actions against peace officers

**LB 542** (Chambers) Eliminate an aggravating circumstance regarding death penalty sentencing hearings

**LB 543** (Chambers) Change a penalty from death to life imprisonment or life imprisonment without possibility of parole

**LB 544** (Hansen) Require notifications regarding bovine trichomoniasis

◆ **LB 545** (Dubas) Change Public Service Commission appeal procedures

**LB 546** (Kolowski) Eliminate review of postsecondary capital construction projects as prescribed

**LB 547** (Kolowski) Provide an income tax credit for payments to school districts for extracurricular activities and character education programs

# 2013 legislative bills

- ◆ **LB 548** (Schilz) Change a length exception for semitrailers transporting baled livestock forage
- ◆ **LB 549** (Schilz) Change the scrap tire recycling sunset provision and fees
- ◆ **LB 550** (Schilz) Adopt the Livestock Growth Act and change provisions of the Nebraska Advantage Rural Development Act
- ◆ **LB 551** (Schilz) Change recreational liability provisions
- LB 552** (Nordquist) Adopt the Cities of the First Class Firefighters Cash Balance Retirement Act
- LB 553** (Nordquist) Change provisions relating to school employee retirement
- LB 554** (Nordquist) Change provisions relating to school employee retirement
- LB 555** (Nordquist) Adopt the Preparing Students for Educational Success Act
- LB 556** (McGill) Provide for telehealth services for children, change the medical assistance program, and provide duties for the Department of Health and Human Services
- ◆ **LB 557** (McGill) Change provisions relating to net metering and authorize community solar gardens
- ◆ **LB 558** (Kintner) Change provisions relating to certain declaratory judgments and illegal taxes paid
- ◆ **LB 559** (Mello) Adopt a short-time compensation program under the Employment Security Law
- ◆ **LB 560** (Mello) Provide enforcement provisions to certain labor and employment acts
- ◆ **LB 561** (Ashford) State findings and intent for changes to the juvenile justice system and a funding mechanism
- ◆ **LB 562** (Ashford) Change provisions of the juvenile justice system
- ◆ **LB 563** (Krist) Change provisions relating to contracts for services
- ◆ **LB 564** (Nelson) Adopt the Health Care Freedom of Conscience Act
- ◆ **LB 565** (Nelson) Prohibit registering to vote and voting early on the same day
- ◆ **LB 566** (Karpisek) Create the Educational Technology Infrastructure Grant Program
- ◆ **LB 567** (Haar) Change provisions relating to approval of electric generation facilities and transmission lines
- LB 568** (Harr) Provide for licensure of insurance navigators
- LB 569** (Harr) Appropriate funds to the Supreme Court for county court employees
- ◆ **LB 570** (Harr) Adopt the Employers Certainty in Records Act
- ◆ **LB 571** (Harr) Adopt the Community Enhancement Financing Assistance Act
- ◆ **LB 572** (Harr) Change the Nebraska Advantage Act and provisions relating to extraordinary dividends and capital gains on certain capital stock
- ◆ **LB 573** (Harr) Change provisions relating to an adjustment to income for certain capital gains and extraordinary dividends
- (League) LB 574** (Harr) Provide that certain assessments are levied and collected as special assessments
- LB 575** (Harr) Provide for professional development training for school board and learning community coordinating council members
- ◆ **LB 576** (Harr) Require flagging of area near polling places and change restrictions on electioneering
- LB 577** (Campbell) Change provisions relating to the medical assistance program

# 2013 legislative bills

**LB 578** (Nordquist) Create a fund to provide funding for medicaid services and change distribution of premium tax revenue

◆ **LB 579** (Karpisek) Provide a duty regarding administration and enforcement of the Nebraska Liquor Control Act

**(League) LB 580** (Johnson) Change certain condemnation procedures

◆ **LB 581** (Crawford) Change the sales and use tax collection fees

◆ **LB 582** (Carlson) Appropriate funds to the Nebraska Tourism Commission

◆ **LB 583** (Haar) Change provisions relating to membership on the Climate Assessment Response Committee and provide duties for the committee

**LB 584** (Smith) Change Nebraska Workers' Compensation Act medical guidelines and independent medical examiner provisions

**LB 585** (Smith) Provide, change, and eliminate provisions relating to learning councils

**LB 586** (Mello) Provide content for rules and regulations relating to child care and preschools

**LB 587** (Schilz) Change provisions of the Livestock Brand Act

◆ **LB 588** (Watermeier) Change veteran employment preference provisions and name the act

◆ **LB 589** (Watermeier) Change provisions of the One-Call Notification System Act

◆ **LB 590** (Lautenbaugh) License and regulate wagering on historic horseracing

◆ **LB 591** (Lautenbaugh) Change civil service commission membership

◆ **LB 592** (Lautenbaugh) Authorize the carrying of concealed handguns by qualified law enforcement officers and qualified retired law enforcement officers

**LB 593** (Lautenbaugh) Adopt the Charter Schools Act

**LB 594** (Price) Provide Nebraska Investment Council duties relating to administration of the Nebraska Veterans' Aid Fund

◆ **LB 595** (Price) Provide for a Public Service Commission study of next-generation 911

◆ **LB 596** (Price) Change provisions relating to specialty license plates and Purple Heart license plates

**LB 597** (Larson) Change provisions relating to county agricultural societies

◆ **LB 598** (Larson) Change provisions relating to net metering

**LB 599** (Sullivan) Change exemptions relating to school budget limitations

**LB 600** (Wightman) Change inheritance tax rates

**LB 601** (Bloomfield) Require notice for natural resources district subcommittee meetings

◆ **LB 602** (Bloomfield) Adopt the Nebraska Firearms Freedom Act

◆ **LB 603** (Chambers) Include affirmation as an alternative when an oath is required

**LB 604** (Haar) Change computation of the cost growth factor relating to state aid to schools

**LB 605** (Pirsch) Provide for Telehealth Behavioral Health Services Program

◆ **LB 606** (Pirsch) Adopt the Nebraska Technology Entrepreneur Act to provide sales and use tax refunds to certain businesses

◆ **LB 607** (Pirsch) Change provisions relating to protection order violations and conditions of release violations

◆ **LB 608** (Pirsch) Change provisions relating to stalking

◆ **LB 609** (Pirsch) Create the Nebraska's Emerging Future Subcommittee of the Legislature's Planning Committee

◆ **LB 610** (Pirsch) Change provisions relating to terroristic threats

# 2013 legislative bills

- ◆ **LB 611** (Pirsch) Redefine serious bodily injury for purposes of domestic assault
- ◆ **LB 612** (Schumacher) Require the Department of Revenue to present reports to legislative committees
- ◆ **LB 613** (Schumacher) Create the Tax Modernization Commission
- (League) LB 614** (Schumacher) Provide for withholding insurance proceeds for demolition costs
- LB 615** (Schumacher) Provide for summary guardianships
- LB 616** (Schumacher) Adopt the Nebraska Money Transmitters Act and eliminate the Nebraska Sale of Checks and Funds Transmission Act and provide penalties
- ◆ **LB 617** (Schumacher) Change provisions of the Nebraska Telecommunications Universal Service Fund Act
- ◆ **LB 618** (Karpisek) Create the Agricultural Land Valuation Task Force
- LB 619** (Haar) Require instruction in sexual health education
- LB 620** (Legislative Performance Audit Committee) Require the Department of Administrative Services and University of Nebraska to present health insurance management plans to the Appropriations Committee
- (League) LB 621** (Karpisek) Exempt certain information from disclosure under the Intergovernmental Risk Management Act
- ◆ **LB 622** (Haar) Change provisions relating to a report filed with the Nebraska Power Review Board
- ◆ **LB 623** (Price) Change provisions relating to bridge construction and road improvements
- ◆ **LB 624** (Pirsch) Provide for fees for copies of motor vehicle accident reports
- LB 625** (Conrad) Change income eligibility provisions relating to federal child care assistance
- ◆ **LB 626** (Conrad) Eliminate an income reduction for extraordinary dividends and certain capital gains
- ◆ **LB 627** (Conrad) Provide for termination of certain tax incentives as prescribed
- ◆ **LB 628** (Conrad) Change and extend the Small Business Innovation Act
- ◆ **LB 629** (Conrad) Provide an additional requirement for the Governor's budget submission
- ◆ **LB 630** (Kolowski) Redefine place of employment for Nebraska Clean Indoor Air Act
- LB 631** (Harr) Change provisions relating to garnishment
- LB 632** (Bolz) Change funding for county offices relating to public assistance programs
- ◆ **LB 633** (Nordquist) Include contract violations under disciplinary provisions of Civil Service Act
- ◆ **LB 634** (Davis) Adopt the Wildfire Control Act of 2013
- ◆ **LB 635** (Wallman) Provide powers and duties regarding hydraulic fracturing to the Nebraska Oil and Gas Conservation Commission
- ◆ **LB 636** (Wallman) Provide restrictions for application of certain herbicides
- ◆ **LB 637** (Wallman) Require an economic analysis of rules and regulations proposed by the Department of Environmental Quality
- ◆ **LB 638** (Nelson) Provide a cash balance retirement system for school employees
- ◆ **LB 639** (Nelson) Make new judges and state patrol officers members of the state employees retirement system
- LB 640** (Hadley) Change provisions relating to the Tax Equity and Educational Opportunities Support Act

# 2013 legislative bills

**LB 641** (Sullivan) Appropriate funds to the Nebraska State Historical Society

◆ **LB 642** (Mello) Prohibit receiving certain types of wagers on horseracing

**(League) LB 643** (Davis) Change certain provisions regarding nuisances in cities and villages

◆ **LB 644** (Davis) Adopt the Contract Carrier Safety Act

**LB 645** (Haar) Change teacher education allowance and fall personnel report provisions

◆ **LB 646** (Murante) Change election provisions for public power districts

◆ **LB 647** (Davis) Change cattle identification provisions of the Animal Importation Act

◆ **LB 648** (Pirsch) Change penalty for public indecency

◆ **LB 649** (Karpisek) Change certain penalties relating to operating a motor vehicle during a revocation period and tampering with an ignition interlock device

◆ **LB 650** (Karpisek) Include asphalt crack filler trailers in the definition of trailer under the Motor Vehicle Registration Act

◆ **LB 651** (Davis) Eliminate property tax levy and provide for state funding of community colleges

◆ **LB 652** (Lautenbaugh) Provide procedures for taking grievances by certain county corrections officers to the Civil Service Commission

◆ **LB 653** (Davis) Change and provide for distribution of the gallonage tax on beer

**LB 654** (Davis) Change the brand inspection area under the Livestock Brand Act

◆ **LB 655** (Carlson) Permit collection of fees for insurance consultants

**LR 40** (Davis) Request the United States Forest Service to reconsider its original decision not to pay a proportionate share of the replacement

costs of fences destroyed by wildfires between private and public lands in certain counties

◆ **LR 41CA** (Lautenbaugh) Constitutional amendment to authorize enactment of laws relating to wagering on live, replayed, and delayed horseraces

**LR 42** (Brasch) Urge Congress to pass the Parental Rights Amendment to the United States Constitution and submit it to the states for ratification

## 2013 Committee Hearings Schedule

**Monday, January 28, 2013**

### **Banking, Commerce and Insurance Room 1507 - 1:30 p.m.**

- LB 213** (Gloor) Change provisions relating to financial institutions  
**LB 214** (Gloor) Change provisions relating to securities and seller-assisted marketing plans  
**LB 279** (Pirsch) Change provisions relating to loan brokers, delayed deposit services, and installment loans  
**LB 290** (Pirsch) Change provisions relating to the Residential Mortgage Licensing Act

### **Business and Labor Room 2102 - 1:30 p.m.**

- LB 58** (Larson) Adopt the Workplace Privacy Act  
**LB 297** (Bolz) Change mental injuries and mental illness compensation under the Nebraska Workers' Compensation Act  
**LB 21** (Lathrop) Eliminate a Nebraska Workers' Compensation Act sunset provision for certain benefits  
**LB 141** (Lathrop) Change court procedures for the Nebraska Workers' Compensation Court  
**LB 291** (Nordquist) Change medical payment provisions of the Nebraska Workers' Compensation Act

### **Education Room 1525 - 1:30 p.m.**

- LB 121** (Lautenbaugh) Provide for waiver of a Nebraska certificate to administer  
**LB 135** (Avery) Change membership provisions relating to Community College Boards of Governors  
**LB 211** (Adams) Change and eliminate provisions relating to statewide coordination of community college boards  
**LB 252** (Adams) Correct and change subdivision

references and references to governmental entities related to postsecondary education

### **Executive Board Room 2102 - 12:00 p.m.**

- LB 39** (Harms) Change and eliminate references to the Legislative Performance Audit Section  
**LB 149** (Pirsch) Provide for biennial reviews of state agency programs and services  
**LR 20** (Lathrop) Provide for continuation of the Developmental Disabilities Special Investigative Committee

### **General Affairs Room 1510 - 1:30 p.m.**

- LB 173** (Coash) Change provisions relating to documentary proof of age under the Nebraska Liquor Control Act  
**LB 230** (Karpisek) Change shipping license provisions under the Nebraska Liquor Control Act  
**LB 259** (Karpisek) Exempt keno writers from licensure under the Nebraska County and City Lottery Act  
**LB 273** (Karpisek) Change keno time limits

### **Transportation and Telecommunications Room 1113 - 1:30 p.m.**

- Appointment** Lahm, Rhonda - Department of Motor Vehicles  
**LB 32** (Hadley) Change provisions relating to historical vehicle license plates  
**LB 207** (McCoy) Change motor vehicle registration provisions  
**LB 249** (Dubas) Change motor vehicle provisions relating to farm vehicles and drivers transporting agricultural commodities or farm supplies  
**LB 250** (Dubas) Change motor vehicle provisions relating to issuance of trip permits

# 2013 Committee Hearings Schedule

**Tuesday, January 29, 2013**

**Agriculture**

**Room 2102 - 1:30 p.m.**

- LB 15** (Krist) Change Pesticide Act provisions
- LB 68** (Schilz) Change provisions of the Plant Protection and Plant Pest Act
- LB 69** (Schilz) Change provisions of the Pesticide Act

**Banking, Commerce and Insurance**

**Room 1507 - 1:30 p.m.**

- LB 209** (Harr) Change provisions relating to publication of trade names
- LB 210** (Harr) Provide remedies and procedures regarding unauthorized financing statement filings
- LB 147** (Gloor) Adopt the Health Carrier External Review Act
- LB 336** (Carlson) Change sickness and accident insurance provisions for policies subject to the federal Patient Protection and Affordable Care Act

**Education**

**Room 1525 - 1:30 p.m.**

- LB 47** (Ashford) Change provisions relating to career academies
- LB 116** (Harms) Provide requirements for dual-enrollment courses
- LB 162** (McGill) Provide for notification of eligibility for an associate degree as prescribed
- LB 254** (Adams) Correct references related to the Nebraska Educational Telecommunications Commission

**Transportation and Telecommunications**

**Room 1113 - 1:30 p.m.**

- Appointment** Gerber, Paul - Motor Vehicle

Industry Licensing Board

- Appointment** Pearson, Ricky - Motor Vehicle Industry Licensing Board

**Appointment** Quinn, Angela - Motor Vehicle Industry Licensing Board

- Appointment** Scherer, Jeff - Motor Vehicle Industry Licensing Board

**LB 164** (Dubas) Change motor vehicle auction provisions

**LB 165** (Dubas) Change provisions relating to motor vehicle dealer warranty service

**Urban Affairs**

**Room 1510 - 1:30 p.m.**

- LB 66** (Schilz) Authorize cities of the first class to annex certain noncontiguous property
- LB 88** (McGill) Change zoning provisions for cities of the primary class
- LB 295** (Sullivan) Redefine a term under the Local Option Municipal Economic Development Act
- LB 31** (Hadley) Change provisions relating to parking permits for temporarily handicapped or disabled persons

**Wednesday, January 30, 2013**

**Government, Military and Veterans Affairs**

**Room 1507 - 1:30 p.m.**

- Appointment** Conway, Sean - Nebraska Accountability and Disclosure Commission
- LB 65** (Schilz) Authorize counties to set sheriff's fees and commissions
- LB 108** (Karpisek) Prohibit counties, cities, and villages from imposing credentialing requirements
- LB 257** (McCoy) Change provisions relating to creation of municipal counties
- LB 311** (Scheer) Change filing requirements for official bonds and oaths

## 2013 Committee Hearings Schedule

### Health and Human Services

#### Room 1510 - 1:30 p.m.

Public Briefings by the Department of Health and Human Services directors, Foster Care Review Office, and the Inspector General of Child Welfare Invited Testimony Only

### Judiciary

#### Room 1113 - 1:30 p.m.

**LB 61** (Murante) Change provisions relating to the Financial Data Protection and Consumer Notification of Data Security Breach Act of 2006

**LB 136** (Avery) Provide for the distribution of administrative fines and costs and forfeited property

**LB 134** (Avery) Provide for inheritance by issue conceived after death

**LB 152** (Dubas) Change eminent domain negotiations

**LB 172** (Coash) Change court filings for guardianships and conservatorships

### Natural Resources

#### Room 1525 - 1:30 p.m.

**Appointment** Reida, Frank - Nebraska Power Review Board

**LB 186** (Christensen) Restrict rule and regulation authority of natural resources districts

**LB 353** (Christensen) Restrict rule and regulation authority of natural resources districts

### Revenue

#### Room 1524 - 1:30 p.m.

**LB 17** (Nordquist) Exempt social security benefits from state income taxation

**LB 74** (Janssen) Exempt social security benefits from state income taxation

**LB 238** (Crawford) Exempt social security and certain retirement benefits from state income taxation

Thursday, January 31, 2013

### Government, Military and Veterans Affairs

#### Room 1507 - 1:30 p.m.

**LB 160** (Schumacher) Provide for electronic signatures on recall, initiative, and referendum petitions

**LB 167** (McCoy) Change balloting and vacancy provisions for presidential electors

**LB 183** (Karpisek) Provide for county board appointment of election commissioners

**LB 188** (Karpisek) Require legislative approval of gubernatorially appointed election commissioners

### Health and Human Services

#### Room 1510 - 1:30 p.m.

**LB 216** (McGill) Adopt the Young Adult Voluntary Services and Support Act

**LB 269** (Campbell) Change provisions relating to children and families

**LB 265** (Coash) Change foster care licensure and kinship home and relative home provisions

### Judiciary

#### Room 1113 - 1:30 p.m.

**LB 226** (Smith) Regulate dealers in the business of purchasing and reselling precious items

**LB 46** (Ashford) Provide for consolidation and coordination of crime laboratories

**LB 106** (Lathrop) Adopt the Uniform Unsworn Foreign Declarations Act and change provisions relating to perjury

**LB 109** (McGill) Provide requirements for precious metals dealers

**LB 161** (McGill) Change a penalty for violation of building ordinances or regulations of a city of the metropolitan class

## 2013 Committee Hearings Schedule

### Natural Resources

#### Room 1525 - 1:30 p.m.

**LB 322** (Karpisek) Require the Department of Natural Resources to conduct an environmental study relating to the Blue River

### Nebraska Retirement Systems

#### Room 1525 - 12:00 p.m.

**LB 638** (Nelson) Provide a cash balance retirement system for school employees

**LB 639** (Nelson) Make new judges and state patrol officers members of the state employees retirement system

### Revenue

#### Room 1524 - 1:30 p.m.

**LB 5** (Krist) Exempt social security benefits and military retirement income from income taxation

**LB 75** (Janssen) Exempt military retirement benefits from taxation as prescribed

**LB 176** (Smith) Exempt military retirement benefits from taxation as prescribed

**LB 227** (Kintner) Exclude retirement benefits from state income taxation

### Friday, February 1, 2013

### Appropriations

#### Room 1003 - 1:30 p.m.

**LB 185** (Christensen) Authorize state assistance for streamflow enhancement projects undertaken by natural resources districts

### Government, Military and Veterans Affairs

#### Room 1507 - 2:00 p.m.

**LB 180** (Adams) Provide for the waiver of education-related fees for dependents of veterans

**LB 224** (Janssen) Provide veterans preference for public contracts as prescribed

### Health and Human Services

#### Room 1510 - 1:30 p.m.

**Appointment** Boldt, Gary (Randy) - Board of Emergency Medical Services

**Appointment** Miller, Michael - Board of Emergency Medical Services

**Appointment** Keely, Sheree - Foster Care Advisory Committee

**Appointment** Timm, Craig - Foster Care Advisory Committee

**LB 245** (Nordquist) Change preferred drug list provisions under the Medical Assistance Act

**LB 484** (Karpisek) Change dental hygienist training and authorized functions

**LB 326** (Howard) Change provisions of Pharmacy Practice Act and Automated Medication Systems Act

### Judiciary

#### Room 1113 - 1:30 p.m.

**LB 277** (Harr) Change provisions relating to presentation of a false medicaid claim

**LB 345** (Wightman) Change transfer on death deed requirements and filings

**LB 289** (Lathrop) Change provisions relating to duration of real estate improvement contract liens

**LB 103** (Lathrop) Change judges' general powers

**LB 232** (Lathrop) Change judges' salaries

### Natural Resources

#### Room 1525 - 1:30 p.m.

**LB 388** (Natural Resources) Change provisions relating to public power and provide for construction of certain transmission lines

## 2013 Committee Hearings Schedule

### Revenue

#### Room 1524 - 1:30 p.m.

**LB 264** (Bolz) Provide an income tax credit for individuals caring for dependents

**LB 296** (Hadley) Change provisions of the educational savings plan relating to income tax reductions and participation agreements

**LB 389** (Bolz) Provide an income tax credit for adoption and guardianship costs

*If auxiliary aids or reasonable accommodations are needed for attendance at a hearing, please call the office of the Clerk of the Legislature, (402) 471-2271, or for persons with hearing impairments, please call the Nebraska Relay System, (800) 833-7352 TTY or (800) 833-0920 Voice. Advance notice of 10 business days is needed when requesting an interpreter.*

### TENTATIVE SCHEDULE

Wednesday, February 6, 2013

### Judiciary

#### Room 1113 - 1:30 p.m.

**LB 22** (Hadley) Change Parenting Act provisions relating to parenting plans

**LB 212** (Karpisek) Change court-ordered parenting plan provisions of the Parenting Act

**LB 124** (Lautenbaugh) Change provisions relating to grandparent visitation

**LB 182** (Avery) Change paternity provisions for a child conceived as a result of sexual assault

**LB 107** (Lathrop) Change waiver of hearing provisions under the Parenting Act

# LEGISLATIVE BULLETIN

## LEAGUE OF NEBRASKA MUNICIPALITIES

103rd Legislature, First Session

Feb. 1, 2013 - Bulletin 4



### ITEMS OF INTEREST TO MUNICIPALITIES

- **LB 21:** Due to negotiated agreement between Sen. Lathrop and insurance companies' lobbyists, League testified in neutral position on bill to remove sunset provision for workers' comp benefits on "mental-mental" claims, but keep June 30, 2014 operative date in original bill passed in 2010
- **LB 108:** League opposes bill to prohibit credentialing of professions and occupations
- **LB 295:** League supports allowing LB 840 economic development programs to include 'relocation incentives for new residents'
- **LB 87, LB 111, LB 112, LB 113:** 4 League bills advance to Select File
- **LB 66:** Urban Affairs Committee hears skip annexation bill
- **LB 273:** General Affairs Committee holds hearing on bill to change keno time limit
- **LB 152:** Judiciary Committee hears bill to add restrictions to eminent domain process

**Please note that in addition to the weekly *Legislative Bulletin*, the League staff will be holding weekly legislative briefings by telephone conference call on the first day of the legislative week (either Monday or Tuesday, if Monday is a recess day) at 9 a.m. CST/8 a.m. MST. The purpose is for the League staff to update League members on key legislative issues and respond to questions. To participate, please call 1-916-209-4534 and enter access number 3971829.**

**LB 21: Due to negotiated agreement between Sen. Lathrop and insurance companies' lobbyists, League testified in neutral position on bill to remove sunset provision for workers' comp benefits on "mental-mental" claims, but keep June 30, 2014 operative date in original bill passed in 2010**

On Jan. 28, the Business and Labor Committee held a hearing on **LB 21**, introduced by **Sen. Steve Lathrop** of Omaha, to repeal a sunset provision on workers' comp claims which allow for compensation for mental injuries and mental illness unaccompanied by physical injury for an employee who is a first responder. Sen. Lathrop testified that in 2010, the Legislature passed LB 780, the "mental-mental" bill. Before LB 780 passed, first responders could only get workers' compensation for emotional injuries if they also had physical injuries.

Sen. Lathrop introduced LB 21 to keep the same operational date that was in LB 780, but repeal the sunset this year in order to prevent a gap in coverage if the Legislature waited to repeal the sunset in 2014. **Section 4 of LB 780 states as follows "the changes made by this legislative bill to the Nebraska Workers' Compensation Act apply only to personal injuries that occurred on or after the effective date of this act and before June 30, 2014." Section 1 of LB 21 states that "this act becomes operative on June 30, 2014."**

Three years ago, the League, lobbyists for the insurance industry and others testified in strong opposition to the initial "mental-mental" bill, predicting that it would create huge liability for state and local govern-

ments with first responders. The bill defined first responders to include police officers, sheriffs, volunteer or paid firefighters, officers of the Nebraska State Patrol and others. In order to obtain coverage for mental injuries without a physical injury, the first responder has to 1) establish, by a preponderance of the evidence, that the employee's employment conditions causing the mental injury or mental illness were "extraordinary and unusual" in comparison to the normal conditions of the particular employment and 2) establish, by a preponderance of the evidence, the medical causation between the mental injury or mental illness and the employment conditions by medical evidence.

Sen. Lathrop emphasized that lobbyists for insurance companies, the League and others three years ago predicted that there would be numerous mental-mental cases and large employer liability. Sen. Lathrop stated that the predictions were a fair consideration three years ago which is why the original sunset was placed in LB 780. However, the predictions have proven to be unfounded. Consequently, he negotiated with lobbyists for the insurance industry to remove the sunset one year earlier than provided in the original bill in order to avoid a gap in coverage. The operational date for LB 780 (2010) and LB 21 (2013)



*Sen. Steve Lathrop*

is June 30, 2014. Unfortunately, there is no way for the League to prevent passage of LB 21 since the lobbyists for the insurance industry and others negotiated an agreement with Sen. Lathrop.

John Corrigan, representing the Nebraska AFL-CIO, testified in strong support of the bill as did the following individuals: Michael Dwyer, an Arlington EMT; Dave Engler, President of the Nebraska Professional Firefighters Association; Jerry Stilmock, representing the Nebraska State Volunteer Firefighters Association and the Nebraska State Volunteer Fire Chiefs Association; and Rick Hitz, representing the Nebraska Association of Trial Attorneys. It was stated that the Nebraska Workers' Comp Court reported that in 2010, there were 42,552 claims of injury and in 2011, there were 43,659 claims of

*Continued on page 3*

## LB 58: League testifies neutral, but outlined serious concerns about the Workplace Privacy Act

On Jan. 28, the Business and Labor Committee held a hearing on **LB 58**, introduced by **Sen. Tyson Larson** of O'Neill, to adopt the Workplace Privacy Act.

Sen. Larson said employers should have very limited rights in accessing an employee's or applicant's social networking site profile or account. Section 4 of the bill provides that:

"An employer or an agent of the employer shall not require an employee or applicant to waive or limit any protection granted under the Workplace Privacy Act as a condition of continued employment or of applying for or receiving an offer of employment. Any agreement to waive any right or protection under the act is against the public

policy of this state and is void and unenforceable."

LB 58 has numerous provisions regarding social networking sites. Representatives on behalf of the Nebraska State Education Association (teachers' union) and the American Civil Liberties Union (ACLU) testified in favor of LB 58.

*Continued on page 4*

## LB 21 advances

*Continued from page 2*

injury. There was only one claim for workers' compensation based on a mental-mental injury.

**Tim Himes**, Assistant City Attorney for Omaha, testified against the bill stating that Omaha opposes early repeal of the sunset provision. Contrary to proponent testimony, he stated that the Omaha Police Department has had two claims for coverage due to mental-mental injuries relating to shootings.

**Mike Nolan**, representing LARM, testified in a neutral position stating that LARM has one member city currently facing a mental-mental claim. He emphasized that it would be important for the committee to consider allowing an employer to review the circumstances of an individual receiving workers' compensation for a mental-mental injury after a period of time has

passed. Nolan stated there should at least be a structure in place for periodic review.

There were two letters submitted in favor of LB 21 and one letter opposing LB 21 from **Joe Patterson**, City Administrator of Hastings. Patterson noted in his letter that Hastings and LARM are currently involved in a case and the sunset should not be eliminated. He suggested that the sunset should be extended to give additional time to determine the original bill's effect on claims statewide.

**Immediately following the hearing, the Business and Labor Committee advanced LB 21 to General File with no dissenting votes. LB 21 was debated on General File on Feb. 1. Sen. Lathrop again stated that the reason for the bill was to avoid**

**a gap in coverage. LB 780, which passed in 2010, and LB 21 have the same operative date of June 30, 2014.**

Sen. Lathrop stated that the lobbyist for the city of Omaha was no longer opposing LB 21. (In discussions with the lobbyist for the city of Omaha, it is clear that the reason for withdrawing opposition is because there was no way to stop the bill in light of the negotiated agreement between Sen. Lathrop and lobbyists for the insurance companies.)

During floor debate, Sen. Tom Carlson of Holdrege stated that if there are numerous mental-mental claims filed between now and next year, there will be legislation to reconsider the issues relating to LB 21.

The Legislature advanced LB 21 to Select File on a vote of 34-0-11.

## LB 58: League testifies neutral, but outlined serious concerns about the Workplace Privacy Act

*Continued from page 3*

Police Chief **Steve Lamken** of Grand Island testified against LB 58 on behalf of the Police Chiefs Association of Nebraska (PCAN). Chief Lamken stated that LB 58 goes too far in limiting the rights of employers. He noted several examples where individuals who were “friends” with a police officer on Facebook contacted the chief or others expressing concern that the police officer had posted highly inappropriate information and pictures on Facebook. Chief Lamken underscored the many unintended consequences of LB 58.

A **League representative** testified in a neutral capacity on LB 58, but outlined serious concerns about the bill. The bill, as originally introduced, states that no employer

shall access an employee’s or applicant’s social networking site profile or account “indirectly through any other person who is a social networking contact of the employee or applicant.”

The overall purpose of the bill is well intended, but the League representative emphasized that the bill would prevent an employer from learning valuable information that might cause liability for the employer. For example, an employer might learn directly or indirectly from an employee’s social networking site that the employee intends to bring guns to the work site or that an employee posted pictures or information that was racist or even information that clearly constitutes sexual harassment of another employee.

Omaha **Sen. Steve Lathrop**, Chair of the Business and Labor Committee, stated that employers might have an affirmative obligation to check an applicant’s or employee’s Facebook account to limit liability for the employer. Sen. Ernie Chambers of Omaha and other members of the committee noted that individuals placing items on social networking sites should assume that it is in the public domain.

Representatives of the Nebraska Realtors Association and Nebraska Chamber of Commerce also testified in a neutral position, but outlined concerns about the bill.

The Nebraska Dept. of Corrections and the Lincoln Police Department sent letters to the committee outlining concerns about the bill.



### Legislative resources

Visit [www.NebraskaLegislature.gov](http://www.NebraskaLegislature.gov) to:

- learn about and contact a Senator
- find the status of bills and resolutions
- research statutes
- view the legislative calendar
- find legislative documents and reports
- watch live coverage of floor debate and committee hearings
- order legislative publications
- browse the Nebraska Blue Book
- learn about the history of Unicameralism
- discover the Legislature's student programs

*Source – Unicameral Update*

## LB 108: League opposes bill to prohibit credentialing of professions and occupations

The Government, Military and Veterans Affairs Committee held a hearing on **LB 108** on Jan. 30. **Sen. Russ Karpisek** of Wilber introduced LB 108 on behalf of contractors and others who do not want to be required to take numerous tests or be credentialed in every municipality in order to conduct business within the city or village.

Section 1 of LB 108 provides: "(1) No county, city, or village is authorized to require any person to be credentialed to conduct business or engage in any profession or occupation within its jurisdiction.

"(2) For purposes of this section, (a) credential includes license, certificate, registration, permit, and any other approval required by the state to engage in a specific profession or occupation, and (b) credential does not include any general approval required of businesses such as a sales and use tax collection permit or a business or occupation tax certificate.

"(3) This section does not apply to licensure of plumbers pursuant to sections 18-1901 to 18-1920 or certification of air conditioning air distribution contractors pursuant to sections 18-2301 to 18-2315."

The bill would amend numerous sections in Chapter 14, which applies to the city of Omaha; Chapter 15, which governs the city of Lincoln; Chapter 16, which applies to cities of the first class; Chapter 17, which applies to cities of the second

class and villages; as well as Sections 23-808 and 23-813.

Sen. Karpisek and others testifying in favor of the bill stated that within Douglas and Sarpy Counties, contractors need to apply for up to 10 different licenses. Norfolk **Sen. Jim Scheer**, former Mayor of Norfolk, asked Sen. Karpisek whether the bill would prohibit a city from requiring a license fee and proof of insurance. Sen. Scheer asked proponents a number of great questions about the detrimental impact of the bill. Sen. Karpisek stated that he thought that cities and villages were using licensing and credentialing as a means of getting more revenue, especially since the Legislature eliminated state aid to municipalities.

Several representatives of contractors testified in favor of the bill. Justin Brady, representing the Nebraska Realtors Association, also supported the bill as did Kathy Siefken, representing the Nebraska Grocery Industry Association and others.

A **League representative** testified in strong opposition to the bill stating that municipalities have police powers granted by statute to protect the health, safety and welfare of citizens. These police powers are the basis for building codes, zoning as well as licensing professions and occupations to protect citizens. The League representative emphasized that when municipalities face tornadoes, floods and other natural disasters, there are numerous indi-

### 2013 LEGISLATIVE SESSION



viduals who come from other states to take advantage of the situation. For example, after a hail storm, many elderly people are contacted by contractors from other states to pay in advance for repairs which never occur. This is one of the reasons why local contractors ask their city or village to impose licensing requirements and proof of insurance for contractors and others doing business within the municipality. Some municipalities require licensing of pawn brokers, tattoo artists, food service workers, junk dealers, auctioneers and street food vendors. LB 108 would prohibit these types of licenses and permits.

**Jay Davis**, Assistant Planning Director in charge of building codes for the City of Omaha, also testified in strong opposition to the bill. He stated that no city requires a license for realtors, however, there are realtors who act as contractors. In Omaha, no permit is required to work on your own property. He emphasized that the building codes adopted by the State of Nebraska establish minimum standards. The **city of Lincoln** sent a letter of op-

*Continued on page 6*

## LB 291: League testifies against bill changing time limits and imposing a 50% penalty for late payment of medical bills under Nebraska Workers' Compensation Act

The Business and Labor Committee held a hearing on **LB 291** on Jan. 28. **Sen. Jeremy Nordquist** of Omaha introduced LB 291 in response to frustration from employees who were struggling because of late medical payments payable due to workers' comp claims. Sen. Nordquist stated that the language in LB 291 is the same as language in current law relating to delinquent payments for disabilities as provided in §48-125. LB 291 would amend §48-125 to add the following language: "All medical payments payable under the

Nebraska Workers' Compensation Act shall be payable within thirty days after notice has been given or within thirty days after the entry of a final order, award, or judgment of the compensation court. If a medical payment is delinquent by thirty days or more, fifty percent shall be added to the amount payable and shall be paid to the employee."

John Corrigan, representing the Nebraska AFL-CIO, testified in support of the bill. He testified that he had a client injured this summer, resulting in a three day hospital stay costing \$55,000. In January 2013,

### 2013 LEGISLATIVE SESSION



the sheriff served him for nonpayment which will result in lowering his credit rating.

Rick Hitz, representing the Nebraska Trial Attorneys, testified in support of LB 291. He stated that in 2012, there were 42,000 reported injuries and only 1,300 petitions filed. He emphasized the importance of having prompt payment for injured parties.

Testifying with a **League representative** against LB 291 were the following individuals: **Korby Gilbertson**, representing the Property Casualty Insurers of America; **Tim Clark**, representing the Nebraska Workers' Comp Fairness and Equity Association as well as the Nebraska Chamber of Commerce; and **Bob Halstrom**, representing the Nebraska Federation of Independent Business and also the Greater Omaha Chamber of Commerce. **Tim Himes**, Assistant City Attorney for Omaha, also testified in strong opposition to the bill. He pointed out that the 30 day provision is unreasonable. In addition,

*Continued on page 7*

## LB 108: League opposes bill to prohibit credentialing of professions and occupations

*Continued from page 5*  
position to LB 108.

Dennis Van Manmoorlegem, representing home building professionals in Omaha (MOBA), testified in opposition to the bill. He stated that in 2005, contractors went to the city of Omaha to get a testing process put in place. Omaha's program, protecting contractors and others, was modeled after a similar program in Kansas City. There was no neutral testimony.

In his closing, Sen. Karpisek stated

that his big concern is the requirement for contractors to take a test and be credentialed in city after city. He again stated that he thinks some municipalities are doing so simply to raise revenue.

Following the hearing, Jay Davis informed the League and others that the city of Omaha and other cities in the metro area are working on reciprocity for testing so that a contractor would only have to take the test once. The League shared this information with Sen. Karpisek.

## LB 295: League supports allowing LB 840 economic development programs to include 'relocation incentives for new residents'

The Urban Affairs Committee held a hearing on LB 295 on Jan. 29.

**Sen. Kate Sullivan** of Cedar Rapids introduced LB 295 to allow municipalities with voter-approved LB 840 economic development programs to have authority to provide “relocation incentives for new residents.”

Sen. Sullivan noted that many small municipalities have higher unemployment rates. She said they also need to attract new residents to their cities and villages. Sen. Sullivan said that the Revenue Committee held a hearing on LR 226, which was an interim study to provide a pilot program to get

individuals to move to rural areas.

**Mike Feeken**, representing the city of St. Paul’s Development Corporation, testified in support of LB 295. **Caleb Pollard**, representing the Ord Area Chamber of Commerce and the Valley Economic Development Corporation, testified in support of the bill indicating the biggest threat to rural Nebraska is the lack of people. **K.C. Belitz**, representing the Columbus Chamber of Commerce, also stressed the need for municipalities to be able to attract more people for their workforce.

A **League representative** testified in strong support of LB 295. LR 11CA was approved by Nebraskans



*Sen. Kate Sullivan*

in 1990, which amended Article XIII, Section 2 of the Nebraska Constitution to provide authority for the Legislature to pass enabling

*Continued on page 8*

## LB 291: League testifies against bill changing time limits and imposing a 50% penalty for late payment of medical bills under Nebraska Workers’ Compensation Act

*Continued from page 6*

the language relating to “notice” is not clear and it is confusing as to when the clock starts running before the penalty provision applies. The **city of Lincoln** also sent a letter in opposition to LB 291.

The League representative stated that it typically takes a minimum of 45 days for insurance companies to process any bill. If the bill does not

have the necessary medical records attached, it takes even more time to obtain proper documentation. In addition, the League representative emphasized that the language in the bill is conflicting and unclear.

In Sen. Nordquist’s closing, he indicated that LB 291 is identical to LB 622, which was introduced in 2009. The Senator stated that LB

622 was advanced to General File with standing committee amendments, but he did not include the standing committee amendments as part of LB 291 this year. Sen. Ernie Chambers of Omaha told Sen. Nordquist that it would have been a good idea to have included those amendments in LB 291. The bill has not been advanced from committee.

## LB 160: Government Panel hears testimony on bill to allow for electronic signatures on petitions

The Government, Military and Veterans Affairs Committee Jan. 31 heard two witnesses oppose and another testify in a neutral position at a hearing on **LB 160**, a bill that would require the Secretary of State to provide for the submission of electronic signatures for recall, state initiative or referendum petitions. The League of Nebraska Municipalities submitted a letter stating a neutral position on the bill.

LB 160, sponsored by Columbus **Sen. Paul Schumacher**, would provide an optional way to collect signatures by using much the same mechanisms used on other documents, such as renewing a driver's license. The bill would allow a means for a qualified signer to review petition content through a secure web site on the Internet and to enter identifying information, he

said. Under the bill's provisions, the signer's information is compared with data from independent state or financial databases to confirm the signer's identity. The bill also would call for the signer to be mailed a postcard confirming the signature with an opportunity to repudiate the signature. Criminal penalties would apply for anyone engaging in fraud.

The bill would provide for filing fees of \$10,000 for an initiative petition proposing a constitutional amendment and \$5,000 for any other petition. These fees would be applied only to filers who do not opt out of the electronic signature option. Sponsors who could not afford the fees may file a qualifying affidavit in lieu of the filing fee, under the bill's provisions.

"The process today is broke. It's not

2013  
LEGISLATIVE  
SESSION



broke for one group. It's not broke for the big moneyed interests that probably are based out of state," Sen. Schumacher said, adding that the petition process today does not exist for average Nebraskans.

He said several changes took place in the petition process that limited its accessibility. For example, he said, the number of signatures required was raised and a requirement is now in place stipulating that 5 percent of the signatures come from 38 different counties. In addition,

*Continued on page 9*

## LB 295: League supports allowing LB 840 economic development programs to include 'relocation incentives for new residents'

*Continued from page 7*

legislation for municipalities to use local sources of revenue for economic or industrial projects or programs, subject to a local vote of the people. In 1991, the Legislature passed LB 840, a League bill to enact the enabling legislation for LR 11CA. There are now 60

municipalities with voter-approved LB 840 plans. The League representative testified that by amending §18-2705 to allow economic development programs to include relocation incentives for new residents, municipalities that have already adopted an LB 840 plan would likely have to go back to the voters

to obtain approval for using funds for this additional purpose. If LB 295 passes, any municipality with an LB 840 plan should consult with legal counsel to determine whether they need to go back to a vote of the people. The League will continue researching this issue.

There was no opposition to the bill.

## LB 87, LB 111, LB 112, LB 113: 4 League bills advance to Select File

On Jan. 30, the Legislature voted to advance four League bills to Select File. The bills were **LB 87** relating to airport authority vacancies, **LB 111** to allow cities and villages to have biennial budgets, **LB 112** to transfer bond recording duties from the city clerk to the city treasurer, and **LB 113** relating to the voting of a mayor in a city of the second class.

All four bills were introduced by **Sen. Amanda McGill** of Lincoln,

Chair of the Urban Affairs Committee. The bills were scheduled for an early hearing by the Urban Affairs Committee, which allows the Legislature to debate and consider them before other bills reach General File.

**LB 87** addresses a concern with filling a vacancy on a city airport authority in cities of the primary, first, and second class and villages. City airport authority members are elected but a vacancy appointment

*Continued on page 10*



*Sen. Amanda McGill*

## LB 160: Government Panel hears testimony on bill to allow for electronic signatures on petitions

*Continued from page 8*

a statute was passed prohibiting paying petition circulators by the signature.

The petition process needs to be available for everyone, Sen. Schumacher told the committee.

Neal Erickson, Deputy Secretary of State for Elections for the Secretary of State's office, opposed the bill and told the committee that there were major problems with the legislation. Erickson said the bill, as drafted, would cover recall, state initiative and referendum petitions. Recall petitions have different rules than do initiative and referendum petitions. For example, he said, a petition signer must be a registered voter at the time the petition was issued. The state initiative requires the signer to be a registered voter at the time the petition is submitted.

The different deadlines cause problems with the verification process, Erickson said.

Erickson said a \$10,000 fee would only cover the cost of postcard mailings for about 21,739 signers and a \$5,000 fee would only cover 10,870 signers. The Secretary of State estimates that the bill initially would cost \$256,586 to establish the system and, according to the Fiscal Note, system costs may be significantly higher.

Jessica Kolterman, representing the Nebraska Farm Bureau Federation, also opposed the bill. Kolterman said the organization opposes use of the Internet for collecting signatures. Organization members are concerned about fraud and about the "digital divide," or lack of access to adequate broadband Internet services in rural areas. Older people

also are less comfortable using the Internet, she said.

Jack Gould of Common Cause testified in a neutral position.

The League sent a letter to the Committee expressing concerns about how the bill relates to the use of electronic signatures for recall petitions. The recall of an elected official is an extraordinary event and the recall process has been abused in the past. Recall petitions can divide a community even if they are not successful. Protections have been placed in the law to make sure that a person asked to sign a recall petition is fully informed about the issue. Petition circulators are required to read the petition and the official subject to the recall is allowed to respond to any allegations in the petition. LB 160 should not be used to weaken these protections.

## LB 87, LB 111, LB 112, LB 113: 4 League bills advance to Select File

*Continued from page 9*

is made by the mayor and confirmed by the council until the next election. LB 87 provides that the appointment is for the whole unexpired term rather than just until the next election. Airport authority members serve six year terms.

Some cities are having trouble filling vacancies because potential authority members do not want to run for election shortly after being appointed. Serving the remainder of the term will make the appointment more attractive and provide stability to the authority. LB 87 will make a vacancy appointment to the city airport authority consistent with a vacancy appointment to the city council in cities of the first and second classes and to the city airport authority in a city of a metropolitan class. Under current law, these appointments are for the remainder of the term.

**LB 111** proposes to amend the State Budget Act to authorize cities of the first and second class and villages to file biennial budgets with the State Auditor's Office and County Clerk. Under the bill, the

decision to change to a biennial budget can be made by a vote of the city council or village board. Budgeting for two years rather than one will give municipalities the opportunity to do more long-range fiscal planning to stabilize expenditures and taxes.

In 2000, the Legislature enacted LB 1116 to authorize cities of the metropolitan (Omaha) and primary (Lincoln) classes to adopt biennial budgeting if the voters of the city authorize the change in the city charter. In 2010, the citizens of Lincoln voted to amend the city charter to allow the city council to file biennial budgets.

**LB 112** transfers duties from a city clerk to a city treasurer in cities of the first and second class and villages. The duties relate to keeping records and reporting on the outstanding bonds of the city or village. Current law requires the clerk to keep a record of all outstanding bonds and to list the bonds issued and sold during the year in the clerk's annual report. This is information that is usually generated by the treasurer and therefore, it is

### 2013 LEGISLATIVE SESSION



more efficient to have the treasurer keep the records and make the report. LB 112 simply transfers these requirements from the clerk to the treasurer.

LB 112 also expands the duties of the treasurer to require the treasurer to prepare lists of all special assessment and collect all special assessments. Current law requires that the treasurer prepare only lists of paving and curbing tax. An obsolete reference to school funds is deleted.

**LB 113** proposes to make changes regarding when the mayor of a city of the second class can vote on an issue before the city council. Under current law, a mayor may vote when the council is evenly divided. LB 113 would authorize the mayor to vote when his or her vote will provide the additional vote required to create a number of votes equal to a majority of the members elected to the council.

This is the current law for mayors in a city of the first class. LB 113 would make the voting authority of a mayor of a city of the second class consistent with that of the mayor of a city of the first class.



**Checkout the League's  
Facebook page  
at [www.facebook.com/  
leaguene](http://www.facebook.com/leaguene). Be sure to "Like" us.**

## LB 273: General Affairs Committee holds hearing on bill to change keno time limit

On Jan. 28, the General Affairs Committee held a hearing on **LB 273** to lower the time limit between keno games from five minutes to three minutes. The bill was sponsored by Wilber **Sen. Russ Karpisek**.

Under current law, a keno operator must wait five minutes after the conclusion of the previous game before the next game can start. LB 273 would reduce the time limit between games to three minutes.

Since 1985, keno has generated more than \$300 million for the counties, cities, and villages whose

voters have approved the implementation of the game. More than 140 of the 530 municipalities have keno. It is the intent of LB 273 to make keno more attractive to players to maintain revenues.

Testifying in support of LB 273 were **Jack Cheloha**, Omaha City Lobbyist, **George Payne**, representing keno operators, **Bill Harvey**, Big Red Keno, and a **League representative**.

The bill was opposed by representatives of the Nebraska Family Council and Gambling with the Good Life.



*Sen. Russ Karpisek*

## LB 152: Judiciary Committee hears bill to add restrictions to eminent domain process

On Jan. 30, the Judiciary Committee held a hearing on **LB 152**, which proposes additional restrictions on the eminent domain process. The bill was introduced by **Sen. Annette Dubas** of Fullerton. The bill was introduced in response to controversies regarding the proposal to build an interstate oil pipeline across the state. Sen. Dubas stated that LB 152 seeks to balance the rights of Nebraska private property owners with the need for infrastructure.

LB 152 requires a present plan and a present public purpose prior to using the power of eminent domain. Such plan and purpose must have been approved by all agencies required, and the condemner to

have all necessary permits and approvals from involved agencies prior to beginning negotiations with the condemnee.

Many of the supporters of the bill were property owners whose land was projected to be taken for the pipeline project. Several supporters complained about how Natural Resources Districts used condemnation authority.

Several public entities opposed the bill, expressing concern that the provisions would delay or stop public infrastructure projects.

**Dan Hoins**, City Administrator of Papillion, testified that LB 152 would have a tremendous negative impact on municipalities. The

requirement that all permits be obtained prior to any negotiations would bring a project to a standstill or completely take the project off the table. This requirement regarding permits is overly burdensome, if not impossible for the condemner.

**Charlie Humble**, speaking on behalf of the Nebraska Power Association and the Nebraska Chamber of Commerce, noted that state law already provides an extensive process for public entities that condemn property. The language in LB 152 causes confusion and is unnecessary.

A **League representative** noted that LB 152 would make govern-

*Continued on page 12*

## LB 66: Urban Affairs Committee hears skip annexation bill

Sen. Ken Schilz of Ogallala introduced **LB 66** on behalf of the City of Sidney to provide a mechanism to bring forward new investment and job opportunities by allowing for a non-contiguous annexation by cities of the first class. The skip annexation would only be allowed if first requested by the property owner of the proposed annexed area that would qualify for redevelopment purposes before going through the proper annexation process.

At a hearing on LB 66 before the Urban Affairs Committee on Jan. 29, Sen. Schilz's legislative aide, **Melissa Hilty**, presented the bill

on Sen. Schilz's behalf. Melissa offered an amendment to the bill that would limit the skip annexation to areas that were formerly military facilities and would require the consent of a city, village, or county if the parcel was in the city's, village's, or county's zoning jurisdiction.

The bill would allow a city of the first class to annex non-contiguous former military facilities that are found to be blighted and substandard and use tax increment financing to redevelop the facility.

**Gary Person**, City Manager of Sidney, testified in support of the bill. He told the Committee about



*Sen. Ken Schilz*

a former army ammunition dump about 10 miles outside of the city that was abandoned in 1967. LB

*Continued on page 13*

## LB 152: Judiciary Committee hears bill to add restrictions to eminent domain process

*Continued from page 11*

ment acquisition of property very difficult and could ultimately create additional costs that will be borne by taxpayers and ratepayers. Most governmental purchases of property, including property purchases through the use of eminent domain, are not massive interstate projects that involve the review of multiple State and Federal agencies. A municipal use of eminent domain might be as simple as condemning an underground pathway under an existing railroad to enlarge a water main. Eminent domain also might also be a tool used to acquire a 30-day easement on private property to park heavy equipment for the

completion of a street or sidewalk project. Municipal governments are very reluctant to use eminent domain and view it as a tool of last resort.

The bill uses the phrase "Present Plan and Purpose," which is very difficult to define and apply to the vast majority of government purchases. Neb. Rev. Stat. 76-704 already requires that the condemner in their petition outline the nature and necessity and purpose of the land use. Neb. Rev. Stat. 76-704 also requires that the government show efforts of good faith negotiation before commencement of eminent domain proceedings. There are numerous court cases

supporting this requirement.

**Bernard in den Bosch**, Omaha Deputy City Attorney, testified that the language in the bill is vague and could be used as a method to delay legitimate acquisitions for infrastructure projects. He noted the differences between a private entity with eminent domain authority and a city. The city is accountable to the property owners through its elected officials.

Also appearing in opposition to the bill were representatives of the Union Pacific Railroad, the BNSF Railroad, NW Energy, Black Hills Energy, and TransCanada Pipeline Company.

## LB 66: Urban Affairs Committee hears skip annexation bill

*Continued from page 12*

66, as amended, would allow the city to use tax increment financing for infrastructure to help private developers to redevelop the facility to bring in new industries and create jobs.

**Don Adams** of Adams Industry told the Committee that his company has invested millions of dollars into the former military facility near Sidney to redevelop the property. Because of the cost of redevelopment other companies are not willing to locate there without tax increment financing (TIF). With TIF, the property would be devel-

oped and jobs would be created.

**Marlan Ferguson**, Executive Director of the Grand Island Development Corporation, testified that the bill would allow TIF to be used to redevelop an ammo depot near Grand Island.

A **League representative** testified in support of the proposed amendment. This amendment narrows the scope of the bill the redevelopment of blighted and substandard former military facilities.

**Joe Kohout**, representing the United Cities of Sarpy County, and **Larry Dix**, representing the Nebraska County Officials Associa-

tion, testified in a neutral position to thank Sen. Schilz for working with them to address concerns.

Opposing the bill were representatives of Adams Central and Grand Island NW School Districts and representatives of Black Hills Energy and Source Gas.

After the hearing, Senators from the committee said that they would be exploring an amendment to allow a former military facility within a certain distance from a city to form a sanitary improvement district and allow the city to provide tax increment financing to the property without having to annex it.

### Frequently Asked Questions about Bills and Laws

#### **How do I request a legislative history?**

Visit the Legislative Histories page.

#### **What is a gutted bill?**

A gutted bill is one that, when introduced, addressed a certain subject matter but whose contents were changed during the legislative process. A bill's content can be "gutted" entirely and replaced with new content, or other provisions can be added to the bill's original content.

#### **What is the Statement of Intent?**

The introducer of a bill will issue a Statement of Intent before a hearing to state what the intent of the bill is at the time of introduction. Any changes made to a bill after it has been introduced will not be reflected in the Statement of Intent. To see what any changes may be, check the history of a bill by using the bill search tools.

#### **When were the statutes last updated?**

After the end of a legislative ses-

sion, all the statutes that are changed with the passage of bills need to be updated. This process is called codification. Once the codification is complete, the statutes are updated and a link will be posted under the Recent Legislative Information section on the home page.

*Source – [http://nebraskalegislature.gov/faq/faq\\_bills.php](http://nebraskalegislature.gov/faq/faq_bills.php)*

## 2013 Committee Hearings Schedule

**Monday, February 4, 2013**

### **Banking, Commerce and Insurance**

**Room 1507 - 1:30 p.m.**

**LB 27** (Hadley) Change experience requirements under the Public Accountancy Act

**LB 337** (Schumacher) Change provisions relating to the Nebraska Insurers Supervision, Rehabilitation, and Liquidation Act

**LB 426** (Howard) Change provisions relating to fraternal benefit societies

**LB 628** (Conrad) Change and extend the Small Business Innovation Act

### **Business and Labor**

**Room 2102 - 1:30 p.m.**

**LB 177** (Smith) Provide enforcement and penalty provisions to the Nebraska Wage Payment and Collection Act

**LB 560** (Mello) Provide enforcement provisions to certain labor and employment acts

**LB 559** (Mello) Adopt a short-time compensation program under the Employment Security Law

**LB 248** (Larson) Provide for seasonal employers under the Employment Security Law

### **Education**

**Room 1525 - 1:30 p.m.**

**LB 480** (Lathrop) Adopt the Nebraska Career Technical Education Grant Program Act

**LB 481** (Lathrop) Create the Career Education Task Force

**LB 366** (Cook) Adopt the Remedial Adult Education Innovation Act

**LB 367** (Cook) Adopt the Twenty-First Century Developmental Education Act

**LB 408** (Sullivan) Change dates and provisions relating to certification and distribution of state aid

### **General Affairs**

**Room 1510 - 1:30 p.m.**

**LB 6** (Krist) Create the Nebraska Commission on Problem Gambling

**LB 413** (Schumacher) Change license violation provisions under the Nebraska Liquor Control Act

**LB 579** (Karpisek) Provide a duty regarding administration and enforcement of the Nebraska Liquor Control Act

### **Transportation and Telecommunications**

**Room 1113 - 1:30 p.m.**

**LB 117** (Harms) Change provisions relating to permits for overweight vehicles

**LB 174** (Mello) Change provisions relating to vehicle load contents and spillage

**LB 398** (Brasch) Change provisions and penalties relating to certain excessively loaded vehicles

**LB 548** (Schilz) Change a length exception for semitrailers transporting baled livestock forage

**Tuesday, February 5, 2013**

### **Agriculture**

**Room 1524 - 1:30 p.m.**

**LB 354** (Larson) Adopt the Nebraska Corn Promotion Act

**LB 431** (Karpisek) Change definition of food establishment under the Nebraska Pure Food Act

**LB 166** (Schilz) Change labeling requirements for lawn and turf seed containers

### **Banking, Commerce and Insurance**

**Room 1507 - 1:30 p.m.**

**LB 170** (Gloor) Rename and expand the purpose of the Nebraska Educational Finance Authority Act

## 2013 Committee Hearings Schedule

**LB 616** (Schumacher) Adopt the Nebraska Money Transmitters Act and eliminate the Nebraska Sale of Checks and Funds Transmission Act and provide penalties

**LB 38** (Wightman) Change provisions relating to testamentary powers

**LB 283** (Conrad) Eliminate the Limited Liability Company Act

### Education

#### Room 1525 - 1:30 p.m.

**LB 539** (Chambers) Prohibit requiring teaching experience for superintendents

**LB 274** (Nordquist) Adopt the Education Compensation Transparency Act

**LB 470** (Scheer) Adopt the Superintendent Pay Transparency Act

**LB 262** (Cook) Provide duties relating to sharing of student information

**LB 129** (Haar) Change the compensation for members of the Board of Educational Lands and Funds

### Transportation and Telecommunications

#### Room 1113 - 1:30 p.m.

**LB 445** (Karpisek) Provide funding to the Department of Motor Vehicles to purchase a vehicle titling and registration computer system

**LB 446** (Avery) Define the term flood damage for purposes of the Motor Vehicle Certificate of Title Act

**LB 624** (Pirsch) Provide for fees for copies of motor vehicle accident reports

**LB 351** (Harms) Require cognitive tests for persons eighty years of age or older obtaining motor vehicle operator's licenses

### Urban Affairs

#### Room 1510 - 1:30 p.m.

**LB 377** (Johnson) Change provisions relating to annexation of a county road by a city or village

**LB 591** (Lautenbaugh) Change civil service commission membership

**LB 633** (Nordquist) Include contract violations under disciplinary provisions of Civil Service Act

**LB 643** (Davis) Change certain provisions regarding nuisances in cities and villages

### Wednesday, February 6, 2013

### Government, Military and Veterans Affairs

#### Room 1507 - 1:30 p.m.

**LB 363** (Avery) Change provisions relating to access to public records

**LB 434** (Price) Provide for emergency management registries for persons with special needs

**LB 510** (Scheer) Change Open Meeting Act telephone conference call provisions and authorization for videoconferencing and teleconferencing

**LB 521** (Christensen) Require cities and villages and other public bodies that maintain web sites to publish ordinances and other information as prescribed

### Health and Human Services

#### Room 1510 - 1:30 p.m.

Licensing briefing by DHHS Division of Public Health (Invited Testimony Only)

**LB 315** (Christensen) Redefine massage therapy and change licensure requirements

**LB 524** (Christensen) Adopt the Pharmacy Audit Integrity Act

**LB 243** (Howard) Redefine nurse practitioner practice

## 2013 Committee Hearings Schedule

### Judiciary

#### Room 1113 - 1:30 p.m.

- LB 22** (Hadley) Change Parenting Act provisions relating to parenting plans
- LB 212** (Karpisek) Change court-ordered parenting plan provisions of the Parenting Act
- LB 124** (Lautenbaugh) Change provisions relating to grandparent visitation
- LB 182** (Avery) Change paternity provisions for a child conceived as a result of sexual assault
- LB 107** (Lathrop) Change waiver of hearing provisions under the Parenting Act

### Natural Resources

#### Room 1525 - 1:30 p.m.

- LB 340** (Natural Resources) Change a hearing requirement related to the Nebraska Power Review Board
- LB 622** (Haar) Change provisions relating to a report filed with the Nebraska Power Review Board

### Nebraska Retirement Systems

#### Room 1525 - 12:00 p.m.

- LB 553** (Nordquist) Change provisions relating to school employee retirement
- LB 554** (Nordquist) Change provisions relating to school employee retirement

### Revenue

#### Room 1524 - 1:30 p.m.

- LB 405** (McCoy) Eliminate certain sales tax exemptions, corporate and individual income taxes, and the franchise tax and change other tax provisions

Thursday, February 7, 2013

### Executive Board

#### Room 2102 - 12:00 p.m.

- LB 18** (Nordquist) Prohibit members of the Legislature and certain constitutional officers from participating in the state insurance program
- LR 1CA** (Larson) Constitutional amendment to change eligibility requirements for members of the Legislature
- LR 31** (Campbell) Provide the Executive Board appoint the Children's Behavioral Health Oversight Committee as a special committee

### Government, Military and Veterans Affairs

#### Room 1507 - 1:30 p.m.

- LB 127** (McGill) Provide for preregistration to vote for 16 and 17 year olds
- LB 206** (Schumacher) Require secret-ballot envelopes for mailed ballots
- LB 219** (Avery) Change petition requirements for general election ballot
- LB 241** (Sullivan) Authorize voters to change election of county offices from partisan to non-partisan

### Health and Human Services

#### Room 1510 - 1:30 p.m.

- LB 105** (Lathrop) Require child care licensees to obtain liability insurance
- LB 555** (Nordquist) Adopt the Preparing Students for Educational Success Act
- LB 270** (Campbell) Provide for a medicaid state plan amendment relating to services for children with serious emotional disturbance

## 2013 Committee Hearings Schedule

### Judiciary

#### Room 1113 - 1:30 p.m.

- LB 403** (Seiler) Prohibit retail sale of novelty lighters
- LB 313** (Christensen) Change provisions relating to incarceration work camps
- LB 350** (Murante) Add members to the Nebraska Police Standards Advisory Council
- LB 267** (Chambers) Prohibit persons on parole, probation, or work release from acting as undercover agents or employees of law enforcement and prohibit admissibility of certain evidence
- LB 115** (Lautenbaugh) Change provisions relating to homicide
- LB 246** (Larson) Provide for a health care co-payment for jail and prison inmates

### Natural Resources

#### Room 1525 - 1:30 p.m.

- LB 94** (Dubas) Change hunting permit provisions
- LB 362** (Avery) Change state park entry permit provisions and provide for a motor vehicle registration fee

### Revenue

#### Room 1524 - 1:30 p.m.

- LB 406** (McCoy) Change tax provisions

**Friday, February 8, 2013**

### Government, Military and Veterans Affairs

#### Room 1507 - 1:30 p.m.

- Appointment** Moody, Tony - Nebraska Tourism Commission
- LB 98** (Mello) Change provisions relating to administrative rules
- LB 371** (Mello) Adopt the Transparency in Government Procurement Act

- LB 372** (Mello) Adopt the Buy Nebraska Act and eliminate provisions relating to resident bidder preferences
- LB 429** (Crawford) Require disclosure of state contracts

### Health and Human Services

#### Room 1510 - 1:30 p.m.

- Appointment** Bonta, John - Board of Emergency Medical Services
- Appointment** Bowlin, Karen - Board of Emergency Medical Services
- Appointment** Hynes, Michelle - Foster Care Advisory Committee
- Appointment** Kruback, Sandra - Foster Care Advisory Committee
- LB 420** (McGill) Provide authorization for disposition of human remains based on military documents
- LB 421** (McGill) Provide powers and duties for professional boards regarding credentialing veterans
- LB 422** (McGill) Provide duties for credentialing boards and temporary practice permits for military spouses

### Judiciary

#### Room 1113 - 1:30 p.m.

- LB 360** (Karpisek) Change court fees, sheriff's fees, identification inspection fees, and handgun certificate fees
- LB 202** (Coash) Change provisions relating to DNA collection
- LB 318** (McGill) Change duties of law enforcement officers and agencies relating to the taking and distribution of fingerprints
- LB 369** (Lathrop) Require licensed service providers for services to probationers and parolees as prescribed

## 2013 Committee Hearings Schedule

**LB 44** (Ashford) Change penalty provisions with respect to Class IA felonies committed by persons under the age of eighteen

### Natural Resources

**Room 1525 - 1:30 p.m.**

**LB 499** (Brasch Change powers and duties of Game and Parks Commission

### Revenue

**Room 1524 - 1:30 p.m.**

**LB 573** (Harr Change provisions relating to an adjustment to income for certain capital gains and extraordinary dividends

**LB 626** (Conrad Eliminate an income reduction for extraordinary dividends and certain capital gains

**LB 327** (Pirsch Change income tax rates

**LB 532** (Conrad Change income tax rates

### TENTATIVE SCHEDULE

**Monday, February 11, 2013**

### Business and Labor

**Room 2102 - 1:30 p.m.**

**LB 19** (Nordquist Change provisions of the Conveyance Safety Act

**LB 437** (Hansen Transfer administration of mechanical safety inspection programs to the State Fire Marshal

**LB 95** (Dubas Adopt the Employee Credit Privacy Act

**LB 163** (McGill Provide for a report on education credentials and workforce needs

**LB 373** (Mello Change Nebraska Construction Prompt Pay Act provisions

### Education

**Room 1525 - 1:30 p.m.**

**Appointment** Engles, Robert - Board of Trustees of the Nebraska State Colleges

**Appointment** Chaney, John - Board of Trustees of the Nebraska State Colleges

**LB 640** (Hadley Change provisions relating to the Tax Equity and Educational Opportunities Support Act

**LB 407** (Sullivan Change calculation provisions under the Tax Equity and Educational Opportunities Support Act

**LB 645** (Haar) Change teacher education allowance and fall personnel report provisions

**LB 416** (Kolowski) Change teacher education allowance provisions relative to the state aid formula

### Executive Board

**Room 2102 - 12:00 p.m.**

**LB 242** (Howard) Change provisions relating to adoption of administrative rules and regulations

**LB 620** (Legislative Performance Audit) Require the Department of Administrative Services and University of Nebraska to present health insurance management plans to the Appropriations Committee

**Tuesday, February 12, 2013**

### Agriculture

**Room 1524 - 1:30 p.m.**

**LB 423** (Agriculture) Change seizure provisions of the Livestock Animal Welfare Act

**LB 550** (Schilz) Adopt the Livestock Growth Act and change provisions of the Nebraska Advantage Rural Development Act

## 2013 Committee Hearings Schedule

### Education

#### Room 1525 - 1:30 p.m.

**Appointment** Smith, Clay - Nebraska Educational Telecommunications Commission

**Appointment** Frye, Curt - Nebraska Educational Telecommunications Commission

**LB 506** (Bolz) Change elementary class size allowance in the state aid formula

**LB 604** (Haar) Change computation of the cost growth factor relating to state aid to schools

**LB 357** (Haar) Change a budget limitation exemption under the Tax Equity and Educational Opportunities Support Act

**LB 469** (Scheer) Change an exemption to school budget lid relating to payments for a voluntary termination

**LB 599** (Sullivan) Change exemptions relating to school budget limitations

### Wednesday, February 13, 2013

### Health and Human Services

#### Room 1510 - 1:30 p.m.

**LB 530** (Dubas) Add, change, and eliminate provisions relating to foster care reimbursements

**LB 443** (Cook) Adopt the Children's Residential Facilities and Placing Licensure Act

**LB 359** (Cook) Change eligibility redeterminations relating to a child care subsidy

### Natural Resources

#### Room 1525 - 1:30 p.m.

**LB 517** (Carlson) Create the Water Sustainability Project Task Force

### Thursday, February 14, 2013

### Health and Human Services

#### Room 1510 - 1:30 p.m.

**Appointment** Dakan, Eileen - Commission for the Deaf and Hard of Hearing

**LB 556** (McGill) Provide for telehealth services for children, change the medical assistance program, and provide duties for the Department of Health and Human Services

**LB 605** (Pirsch) Provide for Telehealth Behavioral Health Services Program

**LB 260** (Gloor) Change requirements for a data and information system under the Nebraska Behavioral Health Services Act

### Natural Resources

#### Room 1525 - 1:30 p.m.

**LB 57** (Larson) Change provisions relating to grants from the Nebraska Environmental Trust Fund

**LB 325** (Brasch) Change provisions relating to approval of natural resources district boundary changes

*If auxiliary aids or reasonable accommodations are needed for attendance at a hearing, please call the office of the Clerk of the Legislature, (402) 471-2271, or for persons with hearing impairments, please call the Nebraska Relay System, (800) 833-7352 TTY or (800) 833-0920 Voice. Advance notice of ten business days is needed when requesting an interpreter.*

# SEND D

Southeast Nebraska Development District

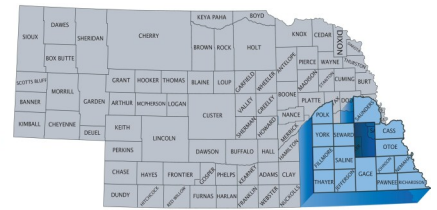

## Increasing Economic Activity with: Intermediary Relending Program – Revolving Loan Fund (IRP-RLF)

The SENDD IRP-RLF loan program is a direct loan fund available to assist new and existing small businesses in the 15 county SENDD service and membership area. SENDD was recently awarded \$223,000 of additional IRP loan funds from USDA-Rural Development. These funds can be used for a wide variety of projects, including business acquisitions, purchase and development of land, equipment, machinery, inventory and working capital.

The purpose of the SENDD IRP-RLF is to increase economic activity, community development and employment opportunities in rural communities. The program is designed to partner with a primary lender, as well as other federal, state and regional funding programs. Loan proceeds can be used for a wide variety of business needs under flexible terms and conditions. Loans up to \$150,000 can be funded through the SENDD IRP-RLF. The interest

rate is fixed for the entire term of the loan, which is a maximum of 15 years.

An excellent example of the use of SENDD IRP loan funds is Geneva Welding and Supply. Geneva Welding and Supply is a manufacturing/welding and trailer sales business owned and operated by Steve Yates. Mr. Yates has managed this successful business in Geneva



since its inception in 1975. With the need to expand operations and improve efficiencies, Steve looked to the SENDD IRP-RLF loan program for funding assistance in the construction of a new commercial building.

With the assistance of Craig Eberle, SENDD Business Loan Officer, a funding package was

developed, including local lender participation from Geneva LB840 funds and SENDD IRP-RLF loan funds. This financial package allowed for the construction of a new commercial building to expand manufacturing operations and metal fabrication/processing. Possessing more advanced electrical and technological systems, this new building has enabled Geneva Welding to take on new jobs and complete them safely and more efficiently.

Through this expansion, Geneva Welding and Supply has now grown to 15 employees, with tasks ranging from traditional maintenance and service to manufacturing of a variety of items. Primary items manufactured are pivot bridges, pivot track closers, pivot stops, tractor saddle tank brackets and related items. Custom manufacturing and trailer sales are also a major component of the business, along with machine shop and portable welding services. Geneva Welding and Supply is located at 510 South 13th Street in Geneva, NE.

For more information on the SENDD IRP Revolving Loan Fund program contact Craig Eberle @ [ceberle@sendd.org](mailto:ceberle@sendd.org); or by phone at 402-475-2560 (Tues. & Thurs.); 402-736-4417 (Mon., Wed. & Fri.).



## JANUARY 2013 NEWSLETTER



### STAFF

**Dave Taladay**

Executive Director  
[dtaladay@sendd.org](mailto:dtaladay@sendd.org)

**Sharon Taylor**

Fiscal Officer  
[staylor@sendd.org](mailto:staylor@sendd.org)

**Ben Volz**

Housing Rehab Specialist  
[bvolz@sendd.org](mailto:bvolz@sendd.org)

**Jim Warrelmann**

Housing Rehab Specialist  
[jwarrelmann@sendd.org](mailto:jwarrelmann@sendd.org)

**John Trouba**

Development Specialist  
[jtrouba@sendd.org](mailto:jtrouba@sendd.org)

**Craig Eberle**

Business Loan Officer  
[ceberle@sendd.org](mailto:ceberle@sendd.org)

**Jen Olds**

Development Specialist  
[jolds@sendd.org](mailto:jolds@sendd.org)

**Emily Bausch**

Development Specialist  
[ebausch@sendd.org](mailto:ebausch@sendd.org)

**Lincoln Office**

2631"O" Street  
Lincoln, NE 68510-1398  
Phone 402-475-2560  
Fax 402-475-2794

**Kevin Burnison**

Development Specialist  
[senddhumboldt@windstream.net](mailto:senddhumboldt@windstream.net)

**Lisa Beethe**

Development Specialist  
[senddlisa@windstream.net](mailto:senddlisa@windstream.net)

**Humboldt Office**

P.O. Box 308  
Humboldt, NE 68376  
Phone 402-862-2201

**Community Development Week  
March 31-April 6, 2013**

Information on Community Development: Nebraska Department of Economic Development's website

<http://www.neded.org/community-development-week>

The National Community Development Association initiated National Community Development Week in 1986. This annual campaign is designed to give local as well as national attention on the numerous outstanding accomplishments over the past 39 years of the Community Development Block Grant (CDBG) program and more than 20 years of the HOME Investment Partnerships (HOME) Program. This year marks the 27th anniversary of the promotion of National Community Development Week.

Suggested Activities for Community Development WEEK:

- Host a Community Development Week proclamation signing
- Honor community member who have Development contributions
- Inspire future projects and set new goals and objectives for the community
- Highlight the value of civic organizations
- Hold an open house at a public facility such as the city hall, library, hospital, fire hall, or community center
- Promote downtown and area businesses with special sales, evening hours, or similar activities
- Plan to meet with your congressional members and discuss your community

**DED 2013 Application Acceptance Dates**

<b>Funding Category</b>	<b>Application Closing</b>
<b><i>Housing</i></b>	
<i>Nebraska Affordable Housing Program</i>	
Annual Cycle	
Pre-application & Threshold Items	March 8, 2013
Application Due	April 30, 2013
<i>CDBG OOR Cycle</i>	
Pre-application & Threshold Items	May 31, 2013
Application Due	July 19, 2013
<b><i>Community Development</i></b>	
<i>Community Investment &amp; Stabilization</i>	
Strategy Application	June 3, 2013
Phase II - Year 1	May 1, 2014
Phase II - Year 2	August 3, 2015
Phase II - Year 2	August 1, 2016
<i>Public Works</i>	
*First Cycle	July 1, 2013
*Second Cycle (If needed)	TBA
<i>Water Wastewater</i>	
Open Cycle, begins May 1, 2013	
<i>Planning</i>	
*First Cycle	April 12, 2013
*Second Cycle	November 1, 2013
*Third Cycle	Open Cycle, begin after Second Cycle
<b><i>Downtown Revitalization</i></b>	
<i>*First Cycle</i>	
Pre-application	March 29, 2013
Planning Phase Implemented	June 2013-March 2014
Phase II Application (Project)	March 28, 2014
*Second Cycle (If needed)	To Be Determined
<b><i>Economic Development</i></b>	
Economic Development	Open Cycle
Tourism Development	Open Cycle begins May 10, 2011

Upcoming: **SouthEast Nebraska Resource Network (SERN) Meeting**  
 March 20, 2013 10:00am  
 Nebraska City Morton James Public Library in the Kimmel Gallery

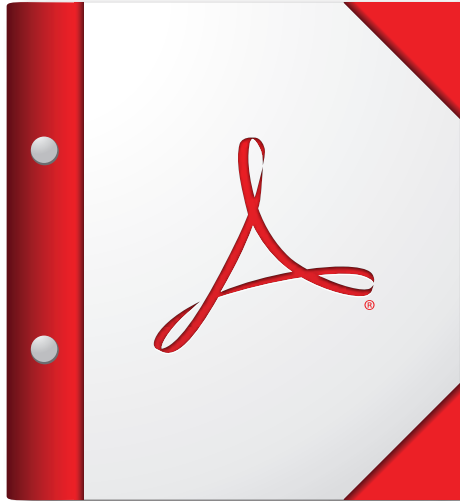

**For the best experience, open this PDF portfolio in  
Acrobat X or Adobe Reader X, or later.**

[Get Adobe Reader Now!](#)

**REGULAR MEETING  
Crete City Council  
City Hall Council Chambers**

**January 15, 2013**

**AGENDA ITEM 1 – OPEN MEETING:**

Mayor Roger Foster called the regular meeting of the City Council to order at 6:00 p.m. Notice of the meeting was given by posting and publishing in The Crete News, the appointed method for giving notice as shown by the Proof of Publication attached to the minutes. Advance notice of the meeting also given to the Mayor and City Council. Pursuant to Section 84-1412(8) of the Nebraska Open Meetings Act, the City has posted a current copy of the Open Meetings Act, Laws of the State of Nebraska, in the back of the Council Chambers. Additional copies are available to read. If one is needed during this meeting, please advise. As each agenda item is considered; if there are any questions concerning the agenda item, please advise. The City may consider items listed on the agenda in random order. All proceedings shown were taken while the meeting was open to the attendance of the public.

Mayor Foster presided and City Clerk Jerry Wilcox recorded the minutes.

Those in attendance pledged allegiance to the flag.

**AGENDA ITEM 2 - ROLL CALL:** (Attendance of the Council members will be recorded to determine the presence of a quorum for official actions.)

Answering roll call were the following council members: Jack Oelschlager, Chuck Vyhnaek, Dave Bauer, Dale Strehle, Tom Busboom and Travis Sears.

**AGENDA ITEM 3 - PETITIONS-COMMUNICATIONS-CITIZEN CONCERN:**  
(No action can be taken by the Council on matters presented under this title except to answer any question posed and/or to refer the matter for further action.) None.

**AGENDA ITEM 4 - SPECIAL ORDER OF BUSINESS:** (The Council may take action to hear testimony in favor of or in opposition to, discuss/limit discussion and take action to approve or disapprove any matter presented under this title.)

**A. Public Hearing – Doane College Bond Issue – 6:05 PM**

Council member Busboom made a motion to open a public hearing to hear testimony in favor of or opposition to the issuing of educational facilities revenue bonds for refinancing and improvements at Doane College. The motion was seconded by Council member Oelschlager. Voting aye: Oelschlager, Vyhnaek, Bauer, Strehle, Busboom, Sears. Voting no: None. Absent: None. Motion carried.

Representatives of Ameritus and Edward Jones explained that the bonds would not exceed \$7,300,000 and would be used in association with similar bonds issued by Saline County to refinance the long term debt of Doane College and to make future improvements yet to be determined by the comprehensive plan. An ordinance authorizing the bonds is on the agenda for tonight.

Council member Vyhnaek made a motion to close the public hearing. The motion was seconded by Council member Strehle. Voting aye: Oelschlager, Vyhnaek, Bauer, Strehle, Busboom, Sears. Voting no: None. Absent: None. Motion carried.

**B. Public Hearing – CDBG – 6:10 PM**

Council member Bauer made a motion to open a public hearing to update and discuss the CDBG Economic Development Loan provided to Novel Chemical Solutions. The motion was seconded by Council member Strehle. Voting aye: Oelschlager, Vyhnaek, Bauer, Strehle, Busboom, Sears. Voting no: None. Absent: None. Motion carried.

Representatives of SENDD explained how the grant was distributed and administered.

Council member Busboom made a motion to close the public hearing. The motion was seconded by Council member Strehle. Voting aye: Oelschlager,

Vyhnalek, Bauer, Strehle, Busboom, Sears. Voting no: None. Absent: None. Motion carried.

**C. Mayor's Appointment**

President Busboom presented the City Council with the name of William Findlay as the Mayor's appointment to the vacant police officer position.

Police Chief Hensel and Lieutenant Young explained the process for taking applications and testing the applicants prior to the Mayor making a choice. Also the training that will be completed before the officer will begin patrolling on his own.

Council member Oelschlager made a motion to approve the appointment of William Findlay to the vacant police officer position. The motion was seconded by Council member Strehle. Voting aye: Oelschlager, Vyhnalek, Bauer, Strehle, Busboom, Sears. Voting no: None. Absent: None. Motion carried.

William Findlay took the oath of office, was presented his badge by Mayor Foster and was congratulated and welcomed by the City Council.

**D. Parking – West 13<sup>th</sup> Street – February 16, 2013**

Police Chief Hensel explained that a fund raiser for the Isis Theater is planned for February 16, 2013 that will require the use of the parking stalls in front of the theater for a stretch limo. They are requesting that those spaces be closed for that evening to accommodate the fund raiser. The Police Department will help with the traffic control.

Council member Bauer made a motion to approve the closing of the parking spaces for that evening. The motion was seconded by Council member Oelschlager. Voting aye: Oelschlager, Vyhnalek, Bauer, Strehle, Busboom, Sears. Voting no: None. Absent: None. Motion carried.

**E. Fire Department Equipment Purchase**

Marty Urbanek of the Volunteer Fire Department was present to request the purchase of a hydraulic cot lift for the transfer ambulance to eliminate the need for volunteers to lift the cots into the unit. The Fire Department requested and reviewed quotes and the cost will be approximately \$25,000. Three year no interest financing is also available.

Council member Bauer made a motion to refer the request to the Public Safety Committee. The motion was seconded by Council member Sears. Voting aye: Oelschlager, Vyhnalek, Bauer, Strehle, Busboom, Sears. Voting no: None. Absent: None. Motion carried.

**AGENDA ITEM 5 - RESOLUTIONS & ORDINANCES:** (The Council may take action to hear testimony in favor of or opposition to, discuss/limit discussion and take action to approve or disapprove any matter presented under this title. The Council may take action to waive the statutory rule requiring reading on three separate dates on any ordinance being considered. The Council may take action to pass and approve any matter presented under this title.)

**A. Ordinance 1845 – Plumbing Code Update**

Council member Strehle introduced Ordinance 1845 and moved that it be approved on the third reading. The clerk was directed to read the ordinance by title.

AN ORDINANCE OF THE CITY OF CRETE, NEBRASKA, TO AMEND CHAPTER 9, ARTICLE 7, SECTION 9-701; PERTAINING TO BUILDING REGULATIONS; PLUMBING CODE; ADOPTED BY REFERENCE; PROVIDING FOR REPEAL OF ALL ORDINANCES AND PARTS OF ORDINANCES IN CONFLICT HERewith; AND PROVIDING FOR A TIME WHEN THIS ORDINANCE SHALL BE IN FULL FORCE AND EFFECT.

Council member Busboom seconded the motion that the ordinance be approved on its third reading by title. Voting aye: Oelschlager, Vyhnalek, Bauer, Strehle, Busboom, Sears. Voting no: None. Absent: None. Motion carried.

Council member Strehle moved for final approval of Ordinance 1845. Council member Busboom seconded the motion for final approval. Voting aye: Oelschlager,

Vyhnalek, Bauer, Strehle, Busboom, Sears. Voting no: None. Absent: None. Motion carried. Mayor Foster declared Ordinance 1846 as an ordinance of the City of Crete.

**B. Ordinance 1847 – Doane College Bonds**

Council member Bauer introduced Ordinance 1847 and moved that the statutory rule requiring reading on three days be waived. The Clerk was directed to read the ordinance by title.

AN ORDINANCE OF THE CITY OF CRETE, NEBRASKA (THE "CITY") AUTHORIZING THE ISSUANCE OF EDUCATIONAL FACILITIES REVENUE AND REFUNDING BONDS (DOANE COLLEGE PROJECT) SERIES 2013 IN THE PRINCIPAL AMOUNT NOT TO EXCEED \$7,300,000 (THE "BONDS") FOR THE PURPOSE OF (1) PROVIDING FUNDS FOR DEFRAYING THE COSTS RELATED TO THE ACQUISITION, CONSTRUCTION AND PURCHASE OF CERTAIN CAPITAL IMPROVEMENTS TO THE CAMPUS OF DOANE COLLEGE (THE "BORROWER") LOCATED IN CRETE, NEBRASKA (THE "PROJECTS"), (2) REFINANCING CERTAIN OUTSTANDING INDEBTEDNESS OF THE BORROWER, (3) FUNDING A DEBT SERVICE RESERVE FUND AND (4) PAYING CERTAIN EXPENSES OF SUCH BOND ISSUE, WHICH BONDS AND THE INTEREST THEREON SHALL BE PAYABLE SOLELY FROM THE REVENUES PLEDGED TO THE PAYMENT OF SAID BONDS; MAKING FINDINGS AND DETERMINATIONS WITH REFERENCE TO THE PROJECTS AND THE BONDS; GRANTING PUBLIC APPROVAL WITHIN THE MEANING OF SECTION 147(F) OF THE INTERNAL REVENUE CODE OF 1986, AS AMENDED; AUTHORIZING THE SALE OF SAID BONDS; APPROVING AND AUTHORIZING THE EXECUTION OF CERTAIN FINANCING DOCUMENTS AND OTHER RELATED DOCUMENTS; APPROVING AND AUTHORIZING THE DISTRIBUTION OF A PRELIMINARY OFFICIAL STATEMENT AND A FINAL OFFICIAL STATEMENT WITH RESPECT TO THE BONDS; DETERMINING THAT SAID BONDS SHALL NOT BE A LIABILITY OF THE CITY NOR A CHARGE AGAINST ITS GENERAL CREDIT OR TAXING POWERS; PROVIDING THAT THE INVALIDITY OF ANY PART OF THIS ORDINANCE SHALL NOT AFFECT THE REMAINDER; DESIGNATING THE BONDS AS QUALIFIED TAX-EXEMPT OBLIGATIONS; PROVIDING FOR THE PUBLICATION OF THE ORDINANCE IN PAMPHLET FORM; AND OTHER RELATED MATTERS.

Council member Strehle seconded the motion. Voting aye: Oelschlager, Vyhnalek, Bauer, Strehle, Busboom, Sears. Voting no: None. Absent: None. Motion carried.

Council member Busboom made a motion for final passage of Ordinance 1847. Council member Bauer seconded the motion. Voting aye: Oelschlager, Vyhnalek, Bauer, Strehle, Busboom, Sears. Voting no: None. Absent: None. Motion carried.

Mayor Foster declared Ordinance 1847 as an ordinance of the City of Crete.

**C. Resolution 2013-04 – Cold Storage**

Council member Busboom introduced Resolution 2013-04 and moved for its approval. The Clerk was directed to read the resolution by title.

NOW, THEREFORE, BE IT HEREBY RESOLVED BY THE MAYOR AND CITY COUNCIL OF THE CITY OF CRETE, NEBRASKA, AS FOLLOWS:

That City hereby directs the City Clerk to send a copy of this resolution to Industry to serve as written notice to Industry that Industry must correct all the deficiencies in its operation and/ or install the necessary pretreatment facilities to correct the violations of the terms of the Agreement by Industry and make Industry's waste stream that drains into City's Wastewater System in full, complete and continuous compliance with all of the terms of the Agreement within 180 days of the receipt of this written notice and if Industry shall fail to correct said violations within the time set forth herein the City will terminate the Agreement between City and Industry on October 1, 2013 and the City will disconnect Industry's connection with the City's wastewater treatment system as of that date.

Council member Bauer seconded the motion. Voting aye: Oelschlager, Vyhnalek, Bauer, Strehle, Busboom, Sears. Voting no: None. Absent: None. Motion carried.

**D. Resolution 2013-05 – Cold Storage**

Council member Busboom introduced Resolution 2013-05 and moved for its approval. The Clerk was directed to read the resolution by title.

NOW, THEREFORE, BE IT HEREBY RESOLVED BY THE MAYOR AND CITY COUNCIL OF THE CITY OF CRETE, NEBRASKA, AS FOLLOWS:

That City hereby directs the City Clerk to send a copy of this resolution to Industry as written notice to Industry that the Agreement between City and Industry set forth herein will be canceled and terminate on November 28, 2015, unless sooner terminated by separate action being taken by City for Industry's default(s), and that all wastewater connection(s) by Industry with the City's Wastewater System will be severed and disconnected by the City at the time of termination.

Council member Bauer seconded the motion. Voting aye: Oelschlager, Vyhnalek, Bauer, Strehle, Busboom, Sears. Voting no: None. Absent: None. Motion carried.

**E. Resolution 2013-06 – Cold Storage**

Council member Strehle introduced Resolution 2013-06 and moved for its approval. The Clerk was directed to read the resolution by title.

NOW, THEREFORE, BE IT HEREBY RESOLVED BY THE MAYOR AND CITY COUNCIL OF THE CITY OF CRETE, NEBRASKA, AS FOLLOWS:

That City hereby directs the City Clerk to send a copy of this resolution to Industry as written notice to Industry that the Contract Fee set by the City of Crete under the terms of the Agreement, which Fee is to be paid by Industry to City, will be changed to the amount of ten percent (10%) of cost of rate per month, commencing January 1, 2013 and will continue for each month thereafter that said Agreement between City and Industry set forth herein remains in effect.

Council member Busboom seconded the motion. Voting aye: Oelschlager, Vyhnalek, Bauer, Strehle, Busboom, Sears. Voting no: None. Absent: None. Motion carried.

**AGENDA ITEM 6 - REPORTS:** (The following reports by committees, officers and elected officials are given concerning current operations of the city. Questions may be asked and answered. No action can be taken by the Council on matters presented under this title except to answer any question posed and to refer the matter for further action.)

Library Director Lisa Olivigni reported that there is good participation in the Cardinal Zone book club and that 25 families have registered for the literacy program.

Police Chief Steve Hensel reported that the new phone system is working good and is providing tools that were not available before.

Public Works Director Tom Ourada reported that: 1) On January 23<sup>rd</sup> the Lieutenant Governor and DED would be in Crete visiting some of the industries. 2) Wholesale electric rates will be going up 9.75%. 3) Later this week the new phone system will be installed at City Hall. 4) New security equipment will be arriving soon. 5) The electric department is still short with injured employees out.

Council member Bauer reported that the Public Works Committee will be meeting on the electric rates and improvements needed to City Hall.

City Clerk Jerry Wilcox reported that registrations will soon be due for the League Mid-Winter Conference in Lincoln on February 25 and 26.

Mayor Foster requested a closed session at the end of the meeting to discuss contract negotiations.

Council member Strehle reported that the Public Safety Committee would be meeting to discuss the Fire Department equipment request.

**AGENDA ITEM 7 - CONSENT AGENDA:** (Council will consider approval of the following items. Explanation may occur for each item and the council may approve and or amend and approve the items listed.)

Council member Busboom moved to approve Consent Agenda items A, B, filing of the treasurer's report for audit and approval of the regular claims as endorsed by the Finance Committee. Council member Sears seconded the motion. Voting aye: Oelschlager, Vyhnaek, Bauer, Strehle, Busboom, Sears. Voting no: None. Absent: None. Motion carried.

**A. Council Minutes**

**1. January 2, 2013**

**B. Committee Minutes**

**1. January 2, 2013 Legislative/ Development**

**2. January 9, 2013 Public Safety**

**C. Treasurer's Report – December 31, 2012 Reports**

**D. Regular Claims (as endorsed by Finance Committee) Total \$835,071.75**

BLACK HILLS ENERGY	NATURAL GAS	\$426.00
CDW GOVERNMENT, INC.	COMPUTER	\$8,403.50
CITY HALL FUND	RENT	\$1,225.00
CITY OF CRETE TAX	SURPLUS/FRANCHISE	\$36,147.50
CITY OF CRETE HEALTH FUND	HEALTH INSURANCE	\$16,715.00
CRETE POSTMASTER	POSTAGE	\$318.00
CRETE TRUE VALUE	SUPPLIES	\$221.74
DEPT. OF ENERGY, W.A.P.A.	PURCHASED POWER	\$30,110.69
EAKES OFFICE PLUS	OFFICE SUPPLIES	\$69.53
GILMORE & ASSOCIATES INC	ENGINEERING	\$2,917.12
HAWKINS, INC	SUPPLIES	\$88.91
JAY'S OIL CO.	SUPPLIES	\$32.10
LINCOLN WINWATER WORKS	SUPPLIES	\$616.66
MCI MEGA PREFERRED	SERVICES	\$17.44
MEAN	PURCHASED POWER	\$414,480.08
MIDLAND SCIENTIFIC, INC	LAB	\$37.48
MIDWEST LABORATORIES, INC	LAB	\$137.50
MIDWEST OFFICE AUTOMATIONS	LEASED EQUIP	\$51.99
MUNICIPAL SUPPLY INC. OF NE	SUPPLIES	\$123.58
NAPA AUTO PARTS	PARTS	\$353.35
NE WATER ENVIRONMENT	MTG & TRNG	\$250.00
NECC	MTG & TRNG	\$11.88
NeDEQ	MTG & TRNG	\$125.00
NeDOL	BOILER CERTIFICATE	\$36.00
NeHHS	FEES	\$489.55
NeHHS LAB	LAB	\$227.00
OLSSON ASSOCIATES	ENGINEERING	\$1,060.49
ONE CALL CONCEPTS INC	SERVICES	\$31.30
PAYROLL	WAGES	\$60,511.26
RESOURCE ACTION PROGRAMS	SERVICES	\$505.75
REVENUE/ELECTRIC FUND	SUPPLIES	\$29.96
SAPP BROS. PETROLEUM, INC	FUEL	\$19,150.47
SKALA'S O.K. TIRE STORE, INC.	TIRE REPAIR	\$140.06
THE GARBAGE COMPANY	SERVICES	\$29,223.35
THE LAW OFFICE, P.C.	SERVICES	\$2,296.80

TOM OURADA	REIMBURSEMENT	\$254.25
U.S. BANK	SUPPLIES	\$37.44
U.S. BANK EQUIPMENT FINANCE	LEASED EQUIP	\$73.16
USABLUEBOOK	SUPPLIES	\$28.28
WALKERS UNIFORM RENTAL	UNIFORMS	\$82.76
WHITEHEAD OIL CO.	FUEL	\$22,635.30
WINDSTREAM	SERVICES	\$427.62
<b>UTILITY FUND</b>	<b>TOTAL</b>	<b>\$650,120.85</b>
ALAMAR UNIFORMS	UNIFORMS	\$70.99
AMERICAN RED CROSS	MTG & TRNG	\$19.00
ART F/X	UNIFORMS	\$26.50
AS CENTRAL FINANCE	NETWK SERV CHARGE	\$448.00
ASHLIE FATINO	REIMBURSEMENT	\$30.53
BLACK HILLS ENERGY	NATURAL GAS	\$250.20
CDW GOVERNMENT, INC.	COMPUTER	\$822.85
CITY HALL FUND	RENT	\$375.00
CITY OF CRETE HEALTH FUND	HEALTH INSURANCE	\$26,695.00
CRETE AREA MEDICAL CENTER	SERVICES	\$35.00
CRETE FLORAL	SERVICES	\$235.00
CRETE FOOD MART	SUPPLIES	\$79.17
CRETE GLASS	SERVICES	\$69.60
CRETE LUMBER & FARM	SUPPLIES	\$557.46
CRETE POSTMASTER	POSTAGE	\$477.00
CRETE TRUE VALUE	SUPPLIES	\$988.66
CRETE VETERINARY CLINIC	BOARDING & DISPOSAL	\$403.74
CRIST AUTO BODY REPAIR	TOWING	\$232.25
DANKO EMERGENCY EQUIP	HOSE & NOZZELS	\$29.43
DAVID COFFEY	SERVICES	\$1,178.70
DEBORAH J ALBERS	REIMBURSEMENT	\$53.47
EAKES OFFICE PLUS	OFFICE SUPPLIES	\$350.88
EMERGENCY MEDICAL PROD	MEDICAL SUPPLIES	\$806.11
FIRST NATN'L BANK OF OMAHA	SUPPLIES	\$62.16
FLAGZ @ THE BRAND	FLAG	\$64.90
GECRB/AMAZON	BOOKS	\$859.31
HARDING & SHULTZ, P.C.,L.L.O	FOP NEGOTIATIONS	\$4,203.46
JAY'S OIL CO.	TIRE REPAIR	\$143.12
KEN MURPHY	PERMIT REFUND	\$36.50
KIRK KELLER	SERVICES	\$165.00
LINCOLN-LANCASTER HEALTH	DUES & MEMBERSHIPS	\$60.00
M & K ENTERPRISES	VEHICLE REPAIR	\$46.23
MCI MEGA PREFERRED	SERVICES	\$48.30
MENARDS	SUPPLIES	\$58.58
MID-STATES ORGANIZED CRIME	DUES & MEMBERSHIPS	\$150.00
MIDWEST OFFICE AUTOMATIONS	LEASED EQUIP	\$116.85
MIKE'S PEST CONTROL	BLDG & GROUNDS MAINT	\$58.00
MUNICIPAL CLERK INSTITUTE	MTG & TRNG	\$446.00
NAPA AUTO PARTS	PARTS	\$338.45
NE DEPT OF LABOR	ELEVATOR INSPECTION	\$100.00
NE DEPT OF REVENUE	LODGING TAX	\$168.26

NE EMERGENCY SERVICE	DUES & MEMBERSHIPS	\$60.00
NE MUNICIPAL CLERKS' ASSOC	DUES & MEMBERSHIPS	\$70.00
NE SNOW EQUIPMENT	PARTS	\$414.72
NMC EXCHANGE LLC	PARTS	\$118.55
NORRIS PPD	UTILITIES	\$9.89
PAPER TIGER SHREDDING	SERVICES	\$30.00
PAYROLL	WAGES	\$127,986.84
PITNEY BOWES	POSTAGE	\$25.75
PRIORITY PRINTING	OFFICE SUPPLIES	\$73.85
RAY SUEPER	REIMBURSEMENT	\$40.52
REVENUE FUND	SERVICES	\$1,067.04
REVENUE/ELECTRIC FUND	FUEL	\$6,126.97
SACK LUMBER CO.	SUPPLIES	\$235.88
SALINE COUNTY CLERK	ELECTION	\$116.51
SAM'S CLUB	SUPPLIES	\$232.97
SEWARD ELECTRONICS	RADIO REPAIR	\$207.35
SHOPKO	SUPPLIES	\$75.94
SKALA'S O.K. TIRE STORE, INC.	TIRE REPAIR	\$139.68
STANARD & ASSOCIATES INC	RECRUITMENT	\$295.00
STAPLES ADVANTAGE	OFFICE SUPPLIES	\$143.97
TELEVISION SERVICE CO.	SERVICES	\$27.81
THE CRETE NEWS	SERVICES	\$605.74
THE LAW OFFICE, P.C.	SERVICES	\$1,531.20
U.S. BANK	SUPPLIES	\$1,451.06
VERIZON WIRELESS	SERVICES	\$8.13
VISA	SUPPLIES	\$164.71
WESCO RECEIVABLES CORP	SUPPLIES	\$360.00
WINDSTREAM	SERVICES	\$1,971.16
<b>TAX FUND</b>	<b>TOTAL</b>	<b>\$184,950.90</b>

**CLOSEED SESSION – AGENDA ITEM 6 – REPORTS:**

Mayor Foster requested a closed session to discuss contract negotiations. Council member Busboom made a motion that the Mayor, City Council, Public Works Director and City Clerk go into closed session at 7:18 PM for the protection of the public interest to discuss contract negotiations. Council member Oelschlager seconded the motion. Voting aye: Oelschlager, Vyhnaelek, Bauer, Strehle, Busboom, Sears. Voting no: None. Absent: None. Motion carried. The Mayor stated that the Mayor, City Council, Public Works Director, and City Clerk will go into closed session for the protection of the public interest to discuss contract negotiations.

Council member Busboom made a motion that the Mayor, City Council, Public Works Director and City Clerk exit the closed session at 7:35 PM. Council member Oelschlager seconded the motion. Voting aye: Oelschlager, Vyhnaelek, Bauer, Strehle, Busboom, Sears. Voting no: None. Absent: None. Motion carried. The City Clerk stated that the Mayor, City Council, Public Works Director, and City Clerk met in closed session for the protection of the public interest to discuss contract negotiations and no action was taken.

**AGENDA ITEM 8 - ADJOURNMENT:**

Council member Busboom moved that the meeting be adjourned at 7:35 PM. Council member Sears seconded the motion. Voting aye: Oelschlager, Vyhnaelek, Bauer, Strehle, Busboom, Sears. Voting no: None. Absent: None. Motion carried.

ATTEST:

\_\_\_\_\_  
City Clerk

\_\_\_\_\_  
Mayor

(S E A L)

I, Jerry L. Wilcox, City Clerk for the City of Crete, hereby certify that the foregoing is a true and correct copy of the proceedings had and done by the Mayor and Council. I hereby certify that a copy of the Open Meetings Act was posted in the back of the Council Chambers. I certify that all of the subjects included in the foregoing proceedings were contained in the agenda for the meeting, kept continually current and available for public inspection at the office of the City Clerk. I certify that such subjects were contained in said agenda for at least twenty-four hours prior to said meeting and that at least one copy of all reproducible material discussed at the meeting was available at the meeting for examination and copying by members of the public. I certify that the minutes were in written form and available for public inspection within ten working days and prior to the next convened meeting of the City Council. I certify that all news media requesting notification concerning meetings of the City Council were provided with advance notification of the time and place of said meeting and the subjects to be discussed.

\_\_\_\_\_  
City Clerk

(S E A L)

**CITY OF CRETE  
PUBLIC WORKS COMMITTEE  
MEETING MINUTES  
January 15, 2013**

Present

Dave Bauer  
Travis Sears  
Tom Busboom

Tom Ourada, Public Works Director  
Amber Frew, Public Works Office  
Roger Foster, Mayor  
Chuck Vyhnalek, Councilmember  
Steve Hensel, Police Chief  
Jerry Wilcox, City Clerk  
Lisa Olivigni, Library  
Ann Howard, Library Representative  
Jim Crouse, Library Representative

1) Comprehensive Plan

Tom Ourada reviewed that the last full comprehensive plan was done in the 1990's and the last update to it was done in 2006. He said some of the assumptions of the last update are outdated and some done in error; with a major portion of it being devoted towards traffic. He suggested we update it again, leveraging the data that the UNL group has compiled. JEO said they would be willing to work with the UNL students and use their data so we wouldn't have to start from scratch. Tom said we could leverage the UNL data into the comprehensive plan update, but it would still cost roughly \$50,000. A complete comprehensive plan would be more extensive. A lot of new Department of Economic Development grants require you to have a working and updated comprehensive plan in order to qualify for some of the Community Black grants that are coming out. A comprehensive plan update would also qualify for LB840 funding, which would make an update financially possible. The Committee agreed that an update is needed. Tom Busboom motioned to proceed with applying for LB840 funding to update the City comprehensive plan. Seconded by Travis Sears. Roll Call Vote: Sears yes; Busboom yes; Bauer yes. Motion passed.

2) Power Plant RICE Retrofit Extension

Tom Ourada informed the Committee that the City filed an extension with the EPA and DEQ saying we will not be RICE compliant by April, but will be shortly after. Tom said the extension is good for one year, but we will have the Power Plant RICE Retrofit completed before then.

3) Alternate Natural Gas Supplier for City Facilities

Tom Ourada reviewed with the Committee the agreement he received from Tyler Rohach with Heartland Natural Gas. They have done a natural gas analysis on City facilities. Tyler estimated he would be able to save the City a minimum of \$2000/year and they would do all of the work. Tom suggested we accept the agreement and said it would not cause any issues with Black Hills Energy. He said Black Hills says they are the transporter and that we can buy gas from them or any third party. In the past we have worked with Black Hills Energy, Cornerstone Energy, as well as other providers. Travis Sears requested we get a formal opinion from the City Attorney regarding the agreement. Tom Busboom motioned to recommend the Council review the agreement from Heartland Natural Gas for approval subject to approval by the City Attorney. Seconded by Travis Sears. Roll Call Vote: Sears yes; Busboom yes; Bauer yes. Motion passed.

4) Electric Rates and Study

Tom reviewed that at the time that JK Energy did our rate study and rate review updates the best information we had from the power pool was that our wholesale power rate was going to go up in the 4.5% range. We have real numbers now that it is going to go up almost 10%. Tom discussed with John Krajewski of JK Energy about how this changes our situation and Tom requested he send us a proposal to do a revised rate review. For \$1500 they will provide us with a revised rate review to

reflect the changes in our wholesale power costs. Tom suggested the City accept JK Energy's proposal to revise the rate study. It would take about three weeks to complete and would cover the next two years. Tom Busboom motioned to recommend Council accept JK Energy's rate study revision proposal for \$1,500. Seconded by Travis Sears. Roll Call Vote: Sears yes; Busboom yes; Bauer yes. Motion passed.

5) One and Six Year Street Plan

Tom Ourada reviewed the One and Six Year Street Plan. The only change would be the addition of replacing the 22<sup>nd</sup> Street Bridge with a triple box culvert for an estimated \$300,000 to the Six Year Plan. Tom mentioned that there is a possibility of getting federal aid for part of the cost. A new triple box culvert would also require a new lift station at an estimated \$190,000. The Committee agreed to the addition. Tom will present the updated One and Six Year Street Plan to the Planning Commission and then to Council.

6) Set Meeting Date for Library and City Hall Discussion

The Committee scheduled a Public Works Committee meeting for January 24<sup>th</sup>, 2013 at 5:00pm to discuss City Hall expenses and the Library project.

It was motioned by Tom Busboom to adjourn the meeting at 5:45 pm. Seconded by Travis Sears. Roll Call Vote: Sears yes; Busboom yes; Bauer yes. Motion passed. Meeting Adjourned.

Dave Bauer, Chairman

**CITY OF CRETE  
PUBLIC WORKS COMMITTEE  
MEETING MINUTES  
January 24, 2013**

Present

Dave Bauer  
Travis Sears  
Tom Busboom

Tom Ourada, Public Works Director  
Amber Frew, Public Works Office  
Lisa Olivigni, Library  
Carol Aden, Library  
Ann Howard, Library Representative  
Lillian Dudley, Library Representative  
Max Sack, Library Representative  
Esther Beile, Library Representative  
Julie Rasgorshek, Library Representative  
Steve Reisdorff, City Attorney

1) Discussion on Library and Repairs Needed at City Hall

Tom Ourada explained that the Mayor has asked to take into consideration what repairs will be needed to city hall in the next 20 years and if it would make sense to combine a new city hall with the new library. Tom had the Building Inspector put together what it would realistically cost to maintain city hall in the next 20 years, which totaled about \$615,000. The new library concept is estimated to cost \$261/sq ft and at that price it would cost roughly an additional \$1.4 million to combine a new city hall with the new library. This amount only takes into consideration the square feet needed for some of the functional spaces currently in city hall and does not include cost for demolition of the old building, which easily has 20 more years of life in it. Tom said it doesn't make sense from an economic stand point. The Committee agreed.

Lisa said the board had concerns about how they would function together. They feel it is important to keep the library a separate entity. Over 70,000 people used the library last year and that kind of traffic in a joint facility could be really problematic.

Dave Bauer said at this point the Committee is not looking at rebuilding city hall or incorporating it into the new library and they will report back to the full Council at the next meeting.

It was motioned by Tom Busboom to adjourn the meeting at 5:15 pm. Seconded by Travis Sears. Roll Call Vote: Sears yes; Busboom yes; Bauer yes. Motion passed. Meeting Adjourned.

Dave Bauer, Chairman

**CITY OF CRETE  
PUBLIC WORKS COMMITTEE  
MEETING MINUTES  
January 28, 2013**

Present

Dave Bauer  
Travis Sears  
Tom Busboom

Tom Ourada, Public Works Director  
Amber Frew, Public Works Office  
Roger Foster, Mayor  
Jerry Wilcox, City Clerk  
Steve Reisdorff, City Attorney

1) Declare street sweeper and dump truck as surplus

Tom Ourada informed the Committee that there is some interest in the old street sweeper and dump truck. Neither unit is being used and will not need to be replaced. He suggested the City declare them as surplus since they are no longer of any use to the City. Tom Busboom recommended Council declare the street sweeper and dump truck as surplus. Seconded by Travis Sears. Roll Call Vote: Sears yes; Busboom yes; Bauer yes. Motion passed.

2) Cogeneration with MEAN

Tom Ourada explained that an energy company out of Lincoln would like to do some cogeneration in Crete. They have a solar project with Doane College mounting photovoltaic cells on the roof of their new building by Padour-Walker, which will require a cogeneration agreement with the City. Tom said that he and Steve Reisdorff can create an agreement and an ordinance that will cover this. The Committee requested Tom and Steve create the agreement and ordinance and take it to Council.

3) Water Rate Ordinance

Tom Ourada reviewed that the Committee and Council previously passed the new water rate ordinance changing the effective date from August 1<sup>st</sup> to October 1<sup>st</sup>, but only 2012. He suggested the Committee adjust the rest of the years as well. Tom Busboom motioned to adjust each instance of August 1<sup>st</sup> to October 1<sup>st</sup> in the water rate ordinance. Seconded by Travis Sears. Roll Call Vote: Sears yes; Busboom yes; Bauer yes. Motion passed.

4) Energy Pioneer Solutions Contract Amendment

Tom Ourada reviewed the request by Energy Pioneer Solutions to amend the current contract. They proposed adding voice recording confirmation and e-signature to Section 5a: Disclosure of Ratepayer Customer Information. The Committee had no issue with this, but requested the City Attorney contact Energy Pioneer Solutions to work out any details and bring it back to the Committee.

Tom Busboom moved to go into executive session at 5:14pm. Seconded by Travis Sears.

Executive session closed at 5:36pm. Contract negotiations were discussed. No action was taken.

It was motioned by Travis Sears to adjourn the meeting at 5:37 pm. Seconded by Tom Busboom. Roll Call Vote: Sears yes; Busboom yes; Bauer yes. Motion passed. Meeting Adjourned.

Dave Bauer, Chairman

1/17/2013

### City of Crete Sales Tax Receipts

Month Collected by Retail	Month Received by City	2010-2011 Net	Net Change yr. to yr.	2011-2012 Net	Net Change yr. to yr.	2012-2013 Net	Net Change yr. to yr.	Change from Net 5 Yr. Average	Net 5 Year Average	Change in Gross Collections yr. to yr.	Change from Gross 5 Yr. Average	Refunds	Net LB840
August	October	\$59,508.91	11.71%	\$62,071.35	4.31%	\$60,629.06	-2.32%	10.96%	\$54,640.42	-2.19%	8.67%	(\$127.75)	\$30,011.38
September	November	\$60,670.75	10.52%	\$56,974.36	-6.09%	\$61,892.19	8.63%	9.75%	\$56,395.02	7.87%	9.33%	(\$60.73)	\$30,636.64
October	December	\$53,496.43	-11.12%	\$56,445.89	5.51%	\$59,758.55	5.87%	12.37%	\$53,182.24	5.87%	11.75%	\$0.00	\$29,580.48
November	January	\$57,875.39	-5.10%	\$56,169.09	-2.95%	\$58,433.42	4.03%	7.57%	\$54,322.57	3.89%	1.89%	(\$0.01)	\$28,924.54
December	February	\$71,957.16	-0.56%	\$63,007.53	-12.44%	\$0.00			\$67,672.17			\$0.00	
January	March	\$50,541.07	-4.73%	\$53,634.41	6.12%	\$0.00			\$53,235.98				
February	April	\$47,173.13	-0.20%	\$55,131.39	16.87%	\$0.00			\$50,542.56				
March	May	\$50,254.12	-11.96%	\$62,176.77	23.72%	\$0.00			\$53,066.86				
April	June	\$45,689.10	-19.00%	\$52,552.17	15.02%	\$0.00			\$52,450.02				
May	July	\$49,156.75	-12.40%	\$60,739.79	23.56%	\$0.00			\$55,172.88				
June	August	\$65,910.29	10.98%	\$65,411.62	-0.76%	\$0.00			\$61,872.08				
July	September	\$55,299.36	-5.05%	\$60,008.61	8.52%	\$0.00			\$57,657.40				
Totals		\$667,532.46	-3.15%	\$704,322.99	<b>6.78%</b>	\$240,713.22	<b>4.05%</b>	Actual	\$670,210.20	<b>3.86%</b>	<b>7.91%</b>	(\$188.49)	\$119,153.04
						\$680,000.00		Budgeted					
						\$56,666.67		Monthly Transfer to General Fund					
						\$58,693.58		Average Net Receipts					

### City of Crete Net Sales Tax Receipts

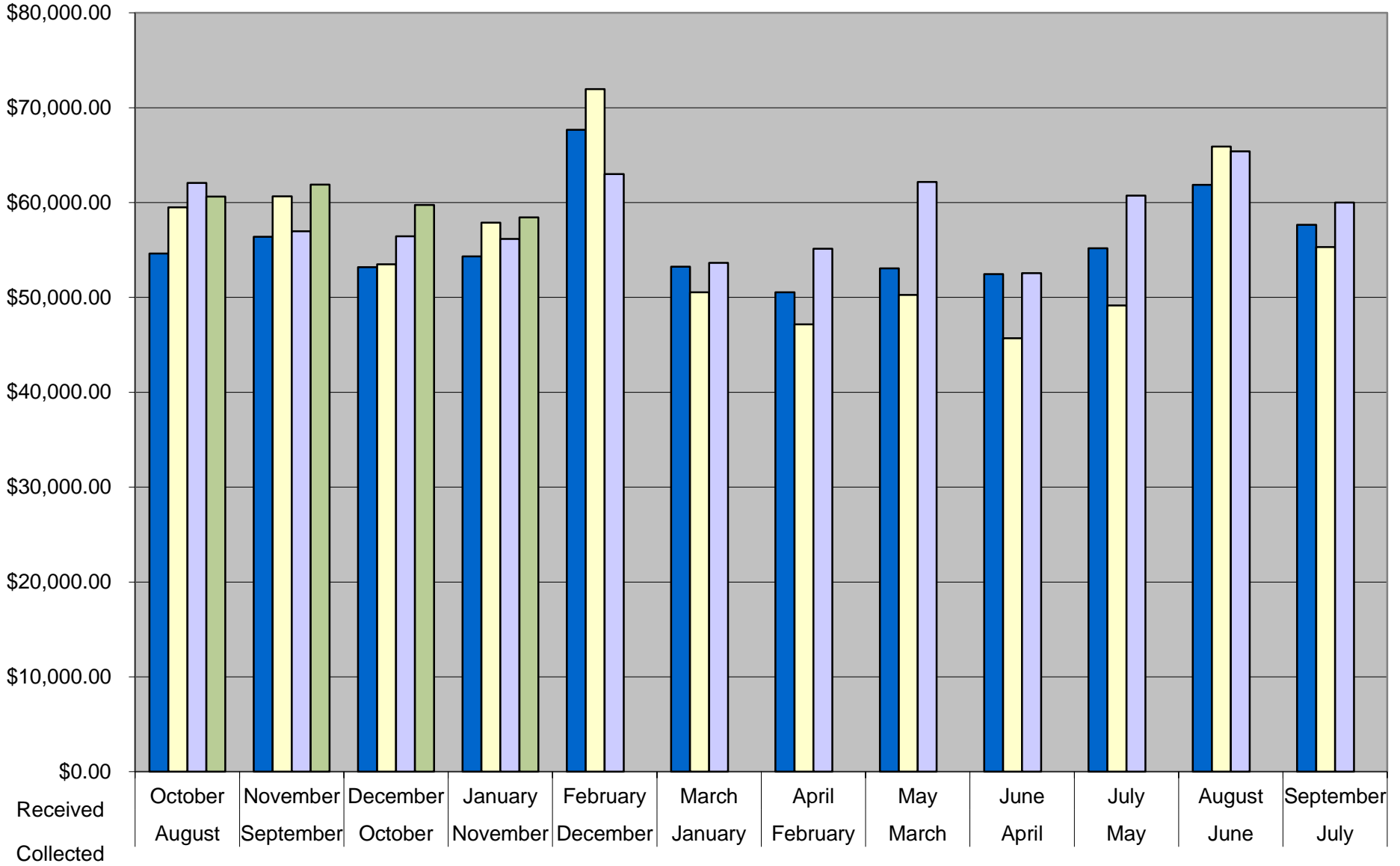
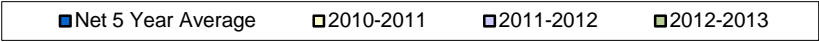

1/31/2013 1:52:06 PM

**General Journal Entry Record**

**January - Tax Deposits (Batch #1593)**

<u>Account</u>	<u>By</u>	<u>WO #</u>	<u>Description</u>	<u>Credit</u>
10-20-4210	1/3/2013	427810	HHS payment	\$508.83
24-10-4480	1/3/2013		UP Railroad mowing	\$135.00
37-10-4070	1/3/2013		Pinnacle Bank cemetery int	\$12.88
37-10-4070	1/3/2013		Pinnacle Bank cemetery int	\$208.60
37-10-4830	1/3/2013		Kuncl Funeral Home internment	\$900.00
38-10-4070	1/3/2013		Pinnacle Bank cemetery int	\$12.88
61-10-2530	1/3/2013		Rev Fund Sewer - Husker Elec.	\$113.20
10-20-4210	1/7/2013	232687	Med B payment	\$342.10
10-20-4210	1/8/2013	137938	Med B payment	\$432.25
10-20-4210	1/8/2013	233041	Med B payment	\$992.66
10-20-4210	1/9/2013	447806	HHS payment	\$274.44
10-10-4300	1/9/2013		Midlands Mechanical plumb reg	\$50.00
10-10-4300	1/9/2013		Culligan plumber reg	\$90.00
10-10-4300	1/9/2013		Action Plumbing plumber reg	\$100.00
10-10-4300	1/9/2013		Pribyl Plumbing plumber reg	\$100.00
10-10-4300	1/9/2013		Crete Lumber plumber reg	\$110.00
10-10-4320	1/9/2013		Miguel Alvarez bldg permit	\$48.00
10-10-4990	1/9/2013		Ray Sueper fax	\$0.25
10-40-4230	1/9/2013		Crete PD parking	\$40.00
10-40-4230	1/9/2013		Crete PD parking	\$60.00
10-40-4940	1/9/2013		Crete PD copier serv	\$20.00
10-40-4990	1/9/2013		Crete PD misc	\$0.55
10-40-4990	1/9/2013		Crete PD misc	\$1.00
10-40-4990	1/9/2013		Crete PD gun permit	\$5.00
10-40-4990	1/9/2013		Crete PD fingerprinting	\$10.00
10-40-4990	1/9/2013		Crete PD gun permit	\$30.00
10-60-4259	1/9/2013		Crete PD st animal lic fee	\$1.00
10-60-4259	1/9/2013		Crete PD st animal lic fee	\$6.00
10-60-4260	1/9/2013		Crete PD vet clinic fees	\$10.50
10-60-4260	1/9/2013		Crete PD animal fines/licenses	\$54.00
10-60-4260	1/9/2013		Crete PD animal fines/licenses	\$73.00
10-60-4261	1/9/2013		Crete PD animal impound	\$20.00
24-10-4410	1/9/2013		Eugene Wit rock gravel	\$319.20
24-10-4480	1/9/2013		Eugene Wit resold labor	\$150.00
24-10-4130	1/10/2013	autodep	State Allocation	\$54,413.93
31-21-4045	1/10/2013	868557	TMCRDC checks	\$9,789.57
10-20-4210	1/14/2013	257073	Med B payment	\$8,616.02
10-10-4300	1/14/2013		Simmons Plumbing plumb reg	\$110.00
10-10-4990	1/14/2013		City Hall Employees coffee maker	\$22.10
24-10-4410	1/14/2013		Columbus Metal Ind scrap metal	\$1,886.70
31-10-4811	1/14/2013		Farmers Merchants 1/2 rural fire	\$9,500.00

<u>Account</u>	<u>By</u>	<u>WO #</u>	<u>Description</u>	<u>Credit</u>
40-10-4340	1/14/2013		School Dist Crete donations	\$95.04
41-10-4870	1/14/2013		CPL replacements	\$47.45
41-10-4870	1/14/2013		CPL book sale	\$94.00
41-10-4870	1/14/2013		CPL non res fee	\$420.00
41-10-4870	1/14/2013		CPL fines	\$590.65
41-10-4940	1/14/2013		CPL copies	\$549.60
10-10-4010	1/15/2013		General	\$45,385.13
10-10-4015	1/15/2013		General	\$5,160.38
50-10-4010	1/15/2013		Bond Fund	\$25,594.49
92-10-4009	1/15/2013		Airport Bonds	\$2,062.82
92-10-4010	1/15/2013		Airport Operations	\$982.40
10-20-4210	1/16/2013	463934	HHS payment	\$54.58
31-21-4045	1/17/2013	876435	TMCRDC checks	\$3,989.36
10-10-4300	1/18/2013		Bret Cerny plumber reg	\$20.00
10-10-4300	1/18/2013		Hier's Plumbing reg	\$50.00
14-10-4017	1/18/2013		Zeilinger Keno Dec.	\$4,116.42
38-10-4070	1/18/2013		Pinnacle Bank cemetery int	\$20.16
11-10-4012	1/22/2013		Monthly Receipts	\$58,433.42
10-10-4990	1/22/2013		Employee health ins	\$379.76
11-10-4990	1/22/2013		1% Admin fee from ED fund	\$292.17
10-40-4990	1/22/2013		Police Dept inmate cash	\$259.50
90-10-2016	1/22/2013		1% Admin fee to gen fund	\$292.17
90-10-2016	1/22/2013		Loan Guarantee Fund	\$1,446.23
90-10-4012	1/22/2013		Monthly Receipts	\$29,216.71
10-10-4011	1/24/2013		Elec Dept surplus	\$25,000.00
10-20-4210	1/24/2013	478032	HHS payment	\$906.96
10-20-4210	1/24/2013	286321	Med B payment	\$5,976.25
10-10-4300	1/24/2013		Zone Telecomm occ tax	\$0.90
10-10-4300	1/24/2013		Vonage Tax Acct occ tax	\$9.00
10-10-4300	1/24/2013		AT&T occ tax	\$10.26
10-10-4300	1/24/2013		Granite Telecomm occ tax	\$29.86
10-10-4300	1/24/2013		Granite Telecomm occ tax	\$33.00
10-10-4300	1/24/2013		Dave Hochstetler plumbing permit	\$36.50
10-10-4300	1/24/2013		TWC Digital Phone LLC occ tax	\$774.38
10-10-4300	1/24/2013		TWC Digital Phone LLC occ tax	\$980.00
10-10-4320	1/24/2013		Foresite Group bldg permit	\$419.00
10-10-4850	1/24/2013		Elec Dept franchise	\$10,000.00
10-10-4990	1/24/2013		Airport Authority billing	\$75.00
10-40-4230	1/24/2013		CPD parking	\$160.00
10-40-4240	1/24/2013		CPD vehicle impound	\$285.00
10-40-4940	1/24/2013		CPD copier serv	\$10.00
10-40-4990	1/24/2013		CPD misc	\$1.25
10-40-4990	1/24/2013		CPD background cks	\$5.00

<u>Account</u>	<u>By</u>	<u>WO #</u>	<u>Description</u>	<u>Credit</u>
10-40-4990	1/24/2013		CPD gun permit	\$10.00
10-60-4259	1/24/2013		CPD st animal lic fee	\$7.00
10-60-4260	1/24/2013		CPD animal fines/lic	\$63.00
16-10-4370	1/24/2013		Tax Depts city hall rent	\$375.00
16-10-4370	1/24/2013		Rev Depts city hall rent	\$1,225.00
24-10-4480	1/24/2013		Martz Trucking cleanup	\$94.68
24-10-4480	1/24/2013		Gana Trucking hauling trees	\$1,540.00
24-10-5970	1/24/2013		Brian Schmidt phone	\$53.49
31-21-4045	1/24/2013	881937	TMCRDC checks	\$4,318.20
34-10-4070	1/24/2013		Pinnacle Bank fire equip 2 int	\$50.41
61-10-2530	1/24/2013		Elec Dept due from other funds	\$1,147.50
10-10-4990	1/25/2013		City Hall Employees coffee maker	\$12.00
10-10-4320	1/28/2013		Tod Allen bldg permit	\$92.94
10-40-4230	1/30/2013		CPD parking fines	\$230.00
10-40-4240	1/30/2013		CPD vehicle impound	\$130.00
10-40-4940	1/30/2013		CPD copier serv	\$25.00
10-40-4990	1/30/2013		CPD misc	\$1.01
10-40-4990	1/30/2013		CPD gun permit	\$20.00
10-60-4260	1/30/2013		CPD vet clinic fees	\$26.76
10-60-4261	1/30/2013		CPD animal impound	\$40.00
24-10-4480	1/30/2013		Crete Lumber barricade rental	\$40.00
34-10-4900	1/30/2013		Harvard Emergency ambulance	\$10,000.00
37-10-4830	1/30/2013		Elizabeth Sanchez grave	\$100.00
39-10-4850	1/30/2013		Waste Connections rebate	\$3,894.00
40-10-4340	1/30/2013		Pinnacle Bank donation	\$1,000.00
42-10-4880	1/30/2013		S & V Young Tuxedo lease	\$150.00
44-10-4370	1/30/2013		Blue Valley WIC rent	\$50.00
			Total Funds	\$323,209.69

# Accounts Payable Detail Listing

CITY OF CRETE												
Pay#	Post Date	Due Date	Amount	Invoice	Date	PO#	Date	Vend#	Vendor Name	Status	Debit	Credit
	Account#	Work Order			Description							
79557	1/24/2013	1/24/2013	275.11					294	AFLAC	Posted		
	10-10-3460				CAFE AFLAC						26.85	0.00
	10-40-3460				CAFE AFLAC						74.70	0.00
	10-60-3460				CAFE AFLAC						49.12	0.00
	24-10-3460				CAFE AFLAC						37.73	0.00
	31-21-3460				CAFE AFLAC						5.78	0.00
	37-10-3460				CAFE AFLAC						0.29	0.00
	42-10-3460				CAFE AFLAC						1.45	0.00
	42-22-3460				CAFE AFLAC						58.73	0.00
	43-10-3460				CAFE AFLAC						0.29	0.00
	43-22-3460				CAFE AFLAC						20.17	0.00
											<u>275.11</u>	<u>0</u>
79558	1/24/2013	1/24/2013	17.13					294	AFLAC	Posted		
	21-10-3445				REG AFLAC						3.43	0.00
	22-10-3445				REG AFLAC						3.43	0.00
	23-10-3445				REG AFLAC						10.27	0.00
											<u>17.13</u>	<u>0</u>
79575	1/24/2013	1/24/2013	101.91					294	AFLAC	Posted		
	21-10-3460				CAFE AFLAC						70.70	0.00
	22-10-3460				CAFE AFLAC						14.73	0.00
	23-10-3460				CAFE AFLAC						16.48	0.00
											<u>101.91</u>	<u>0</u>
79638	2/5/2013	2/5/2013	50.00	A/A11888				245	AIRPORT AUTHORITY	Posted		
	10-10-5360				HANGER RENT #2						50.00	0.00
79617	2/5/2013	2/5/2013	55.00						RUTH ALBRECHT	Posted		
	10-40-5970				MISC OP						55.00	0.00
79539	1/17/2013	1/17/2013	190.00						CHICAGO AMERICAN LIBRARY ASSOCIACK# 74823	Printed		
	41-10-5400				DUES & MEMBERSHIPS						190.00	0.00
79734	2/5/2013	2/5/2013	448.00	793547					US COMM AS CENTRAL FINANCE	Posted		
	10-40-5550				NETWK SERV CHARGE						448.00	0.00
79551	1/17/2013	1/17/2013	1,071.02						BAKER & TAYLOR	Ck# 74824	Printed	
	41-10-5691				AD BKS						90.84	0.00
	41-10-5691				AD BKS						562.76	0.00
	41-10-5691				JV BKS						417.42	0.00
											<u>1071.02</u>	<u>0</u>
79604	2/5/2013	2/5/2013	1,116.21	75230					BEATRICE CONCRETE CO.	Posted		
	22-10-1700				CONCRETE/GRAVEL						1,116.21	0.00
79605	2/5/2013	2/5/2013	52.75	75229					BEATRICE CONCRETE CO.	Posted		
	24-10-5980				CONCRETE						52.75	0.00
79658	2/5/2013	2/5/2013	188.75	75116					BEATRICE CONCRETE CO.	Posted		
	24-10-5980				ROCK PU						188.75	0.00
79659	2/5/2013	2/5/2013	732.81	75115					BEATRICE CONCRETE CO.	Posted		
	24-10-5980				ROCK PU						732.81	0.00
79660	2/5/2013	2/5/2013	303.91	75117					BEATRICE CONCRETE CO.	Posted		
	24-10-5980				ROCK PU						303.91	0.00
79661	2/5/2013	2/5/2013	173.69	75118		164			BEATRICE CONCRETE CO.	Posted		
	22-10-1700				CONCRETE/DARASET/REBAR						173.69	0.00
79695	2/5/2013	2/5/2013	171.53	75339					BEATRICE CONCRETE CO.	Posted		
	24-10-5980				CONCRETE SAND						171.53	0.00



# Accounts Payable Detail Listing

CITY OF CRETE										
<u>Pay#</u>	<u>Post Date</u>	<u>Due Date</u>	<u>Amount</u>	<u>Invoice</u>	<u>Date</u>	<u>PO#</u>	<u>Date</u>	<u>Vend#</u>	<u>Vendor Name</u>	<u>Status</u>
	<u>Account#</u>	<u>Work Order</u>			<u>Description</u>				<u>Debit</u>	<u>Credit</u>
79566	1/24/2013	1/24/2013	1,569.02						410.44	0
	10-10-3455				CAFE HEALTH				481.09	0.00
	10-30-3455				CAFE HEALTH				196.44	0.00
	10-40-3455				CAFE HEALTH				196.44	0.00
	24-10-3455				CAFE HEALTH				564.18	0.00
	37-10-3455				CAFE HEALTH				8.84	0.00
	42-10-3455				CAFE HEALTH				29.74	0.00
	42-22-3455				CAFE HEALTH				68.36	0.00
	43-10-3455				CAFE HEALTH				1.14	0.00
	43-22-3455				CAFE HEALTH				22.79	0.00
									1569.02	0
79567	1/24/2013	1/24/2013	378.20							
	10-10-3455				REG HEALTH				3.68	0.00
	10-40-3455				REG HEALTH				373.30	0.00
	24-10-3455				REG HEALTH				1.22	0.00
									378.2	0
79578	1/24/2013	1/24/2013	1,305.04							
	21-10-3455				CAFE HEALTH				452.70	0.00
	22-10-3455				CAFE HEALTH				401.99	0.00
	23-10-3455				CAFE HEALTH				450.35	0.00
									1305.04	0
79579	1/24/2013	1/24/2013	4.89							
	21-10-3455				REG HEALTH				2.45	0.00
	22-10-3455				REG HEALTH				1.22	0.00
	23-10-3455				REG HEALTH				1.22	0.00
									4.89	0
79636	2/5/2013	2/5/2013	379.76							
	10-10-4990				HEALTH INS				379.76	0.00
79740	2/5/2013	2/5/2013	26,695.00							
	10-10-5160				FEBR HEALTH INS				4,296.00	0.00
	10-30-5160				FEBR HEALTH INS				3,544.00	0.00
	10-40-5160				FEBR HEALTH INS				7,715.00	0.00
	10-60-5160				FEBR HEALTH INS				626.00	0.00
	24-10-5160				FEBR HEALTH INS				5,278.00	0.00
	37-10-5160				FEBR HEALTH INS				313.00	0.00
	39-10-5160				FEBR HEALTH INS				251.00	0.00
	41-10-5160				FEBR HEALTH INS				1,879.00	0.00
	42-10-5160				FEBR HEALTH INS				1,522.00	0.00
	42-22-5160				FEBR HEALTH INS				1,271.00	0.00
									26695	0
79741	2/5/2013	2/5/2013	16,715.00							
	21-10-9620				FEBR HEALTH INS				6,429.00	0.00
	22-10-9620				FEBR HEALTH INS				6,602.00	0.00
	23-10-9620				FEBR HEALTH INS				3,684.00	0.00
									16715	0
79737	2/5/2013	2/5/2013	240.00			166		1081	DAVID COFFEY	Posted
	16-10-5750				CONTRACT SERV				240.00	0.00

# Accounts Payable Detail Listing

CITY OF CRETE										
Pay#	Post Date	Due Date	Amount	Invoice	Date	PO#	Date	Vend#	Vendor Name	Status
	Account#	Work Order			Description				Debit	Credit
79738	2/5/2013	2/5/2013	426.00		CONTRACT SERV			1081	DAVID COFFEY	Posted
	41-10-5750								426.00	0.00
79739	2/5/2013	2/5/2013	210.00		GEN MAINT			1081	DAVID COFFEY	Posted
	10-40-5329								210.00	0.00
79603	2/5/2013	2/5/2013	378.99	34414	MOTOR			385	COLIN ELECTRIC MOTOR SER	Posted
	23-10-7201								378.99	0.00
79569	1/24/2013	1/24/2013	138.12		GARNISHMENT - CMS				CREDIT MANAGEMENT SERV	Ck# 74843 Printed
	42-10-3476								138.12	0.00
79536	1/17/2013	1/17/2013	3,353.83		OUTSIDE SERV				CRETE AREA MEDICAL CENTE	Ck# 74826 Printed
	10-20-5340								3,353.83	0.00
79735	2/5/2013	2/5/2013	2,200.00		MTG & TRNG				CRETE AREA MEDICAL CENTE	Posted
	31-21-5470								2,200.00	0.00
79736	2/5/2013	2/5/2013	35.00		LAUNDRY SERV				CRETE AREA MEDICAL CENTE	Posted
	10-20-5971								35.00	0.00
79798	2/5/2013	2/5/2013	73.00		DUES & MEMBERSHIP			516	CRETE CHAMBER OF COMME	Posted
	10-10-5400								73.00	0.00
79540	1/17/2013	1/17/2013	79.83		PROGRAM EXP			LIBR	CRETE FOOD MART	Ck# 74827 Printed
	41-10-6210				JANITORIAL SUPPLIES				26.64	0.00
	41-10-5541								53.19	0.00
									79.83	0
79608	2/5/2013	2/5/2013	6.60		JANITORIAL SUPPLIES			LIBR	CRETE FOOD MART	Posted
	21-10-7230								6.60	0.00
79612	2/5/2013	2/5/2013	35.95		MISC OP			LIBR	CRETE FOOD MART	Posted
	10-40-5970								35.95	0.00
79665	2/5/2013	2/5/2013	6.21		CONTRACT NEG			GEN	CRETE FOOD MART	Posted
	10-10-5384								6.21	0.00
79653	2/5/2013	2/5/2013	5.98	307184	BLDG/GROUNDS MAINT				CRETE LUMBER & FARM SUPP	Posted
	42-10-5332								5.98	0.00
79753	2/5/2013	2/5/2013	9.43	307039	MAINT H2O MAINS				CRETE LUMBER & FARM SUPP	Posted
	22-10-8021								9.43	0.00
79667	1/31/2013	1/31/2013	741.45		UTIL POSTAGE			330	CRETE POSTMASTER	Ck# 23111 Printed
	21-10-9650								741.45	0.00
79533	1/16/2013	1/16/2013	31.20	A341030	MAINT H2O MAINS			2122REV	CRETE TRUE VALUE (ELEC/W	Ck# 23103 Printed
	22-10-8021								31.20	0.00
79534	1/16/2013	1/16/2013	56.65	A340654	JANITORIAL SUPPLIES			X FUNDS	CRETE TRUE VALUE HDW	Ck# 74821 Printed
	16-10-5541								56.65	0.00
79706	2/5/2013	2/5/2013	2,059.75		MTG & TRNG			236	CRETE VOLUNTEER FIRE DE	Posted
	31-21-5470				OFFICE SUPPLIES/POSTAGE				70.00	0.00
	31-10-5532				RETENTION				130.75	0.00
	31-10-5500				EQUIPMENT				586.00	0.00
	10-20-5331								1,273.00	0.00
									2059.75	0
79613	2/5/2013	2/5/2013	110.00	11893	TOWING			8	CRIST AUTO BODY REPAIR	Posted
	10-40-5812								110.00	0.00
79543	1/17/2013	1/17/2013	32.50		UTIL			72	CULLIGAN WATER SERVICE	Ck# 74828 Printed
	41-10-5210								32.50	0.00
79709	2/5/2013	2/5/2013	107.70	16587178	OFFICE SUPPLIES/POSTAGE		167		DE LAGE LANDEN	Posted
	31-10-5532								107.70	0.00
79593	1/24/2013	1/24/2013	95.04	2012121301					DEL SOL BOOKS	Ck# 74845 Printed

# Accounts Payable Detail Listing

CITY OF CRETE

<u>Pay#</u>	<u>Post Date</u>	<u>Due Date</u>	<u>Amount</u>	<u>Invoice</u>	<u>Date</u>	<u>PO#</u>	<u>Date</u>	<u>Vend#</u>	<u>Vendor Name</u>	<u>Status</u>
	<u>Account#</u>	<u>Work Order</u>			<u>Description</u>				<u>Debit</u>	<u>Credit</u>
79623	2/5/2013	2/5/2013	612.77	S1211207	BOOKS				95.04	0.00
	21-10-9910				SOFTWARE & UPGRADES				204.26	0.00
	22-10-9910				SOFTWARE & UPGRADES				204.26	0.00
	23-10-9910				SOFTWARE & UPGRADES				204.25	0.00
									612.77	0
79549	1/17/2013	1/17/2013	270.00		BOOKS, MAG				263.92	0.00
	41-10-5691				S & H				6.08	0.00
	41-10-6030								270	0
79629	2/5/2013	2/5/2013	882.50	S53025-1	STREET LIGHTING			680 DUTTON LAINSON COMPANY	882.50	0.00
79595	2/5/2013	2/5/2013	25.95	6036937-0	OFFICE SUPPLIES			EAKES OFFICE PLUS	25.95	0.00
79606	2/5/2013	2/5/2013	55.25	6036932-0	OFFICE SUPPLIES			EAKES OFFICE PLUS	18.42	0.00
	21-10-9900				OFFICE SUPPLIES				18.42	0.00
	22-10-9900				OFFICE SUPPLIES				18.41	0.00
	23-10-9900				OFFICE SUPPLIES				55.25	0
79607	2/5/2013	2/5/2013	77.23	6036935-0	OFFICE SUPPLIES			EAKES OFFICE PLUS	77.23	0.00
79671	2/5/2013	2/5/2013	27.80	6042601-0	OFFICE SUPPLIES			EAKES OFFICE PLUS	27.80	0.00
79571	1/24/2013	1/24/2013	8,487.86		SOC SECURITY			EFTPS	717.70	0.00
	10-10-3435				SOC SECURITY				274.08	0.00
	10-20-3435				SOC SECURITY				976.88	0.00
	10-30-3435				SOC SECURITY				2,476.34	0.00
	10-40-3435				SOC SECURITY				152.78	0.00
	10-60-3435				SOC SECURITY				15.56	0.00
	16-10-3435				SOC SECURITY				1,327.92	0.00
	24-10-3435				SOC SECURITY				16.26	0.00
	31-10-3435				SOC SECURITY				755.06	0.00
	31-21-3435				SOC SECURITY				57.38	0.00
	37-10-3435				SOC SECURITY				43.36	0.00
	39-10-3435				SOC SECURITY				1,006.22	0.00
	41-10-3435				SOC SECURITY				347.76	0.00
	42-10-3435				SOC SECURITY				230.54	0.00
	42-22-3435				SOC SECURITY				1.60	0.00
	43-10-3435				SOC SECURITY				72.86	0.00
	43-22-3435				SOC SECURITY				15.56	0.00
	44-10-3435				SOC SECURITY				8487.86	0
79572	1/24/2013	1/24/2013	1,984.98		MEDICARE			EFTPS	167.74	0.00
	10-10-3435				MEDICARE				64.08	0.00
	10-20-3435				MEDICARE				228.46	0.00
	10-30-3435				MEDICARE				579.14	0.00
	10-40-3435				MEDICARE				35.72	0.00
	10-60-3435				MEDICARE				3.64	0.00
	16-10-3435				MEDICARE					

# Accounts Payable Detail Listing

CITY OF CRETE

<u>Pay#</u>	<u>Post Date</u>	<u>Due Date</u>	<u>Amount</u>	<u>Invoice</u>	<u>Date</u>	<u>PO#</u>	<u>Date</u>	<u>Vend#</u>	<u>Vendor Name</u>	<u>Status</u>
	<u>Account#</u>	<u>Work Order</u>		<u>Description</u>					<u>Debit</u>	<u>Credit</u>
	24-10-3435			MEDICARE					310.60	0.00
	31-10-3435			MEDICARE					3.80	0.00
	31-21-3435			MEDICARE					176.62	0.00
	37-10-3435			MEDICARE					13.40	0.00
	39-10-3435			MEDICARE					10.14	0.00
	41-10-3435			MEDICARE					235.32	0.00
	42-10-3435			MEDICARE					81.36	0.00
	42-22-3435			MEDICARE					53.90	0.00
	43-10-3435			MEDICARE					0.38	0.00
	43-22-3435			MEDICARE					17.04	0.00
	44-10-3435			MEDICARE					3.64	0.00
									<u>1984.98</u>	<u>0</u>
79573	1/24/2013	1/24/2013	6,531.34						EFTPS	ACH 20101373
	10-10-3425			FED MARRIED					340.91	0.00
	10-20-3425			FED MARRIED					0.88	0.00
	10-30-3425			FED MARRIED					226.04	0.00
	10-40-3425			FED MARRIED					655.66	0.00
	24-10-3425			FED MARRIED					718.16	0.00
	31-10-3425			FED MARRIED					11.28	0.00
	31-21-3425			FED MARRIED					99.99	0.00
	37-10-3425			FED MARRIED					34.33	0.00
	39-10-3425			FED MARRIED					26.90	0.00
	41-10-3425			FED MARRIED					305.89	0.00
	42-10-3425			FED MARRIED					95.49	0.00
	42-22-3425			FED MARRIED					26.75	0.00
	43-10-3425			FED MARRIED					1.03	0.00
	43-22-3425			FED MARRIED					8.92	0.00
	10-20-3425			FED SINGLE					119.77	0.00
	10-30-3425			FED SINGLE					671.70	0.00
	10-40-3425			FED SINGLE					1,516.76	0.00
	10-60-3425			FED SINGLE					131.80	0.00
	24-10-3425			FED SINGLE					318.13	0.00
	31-21-3425			FED SINGLE					146.06	0.00
	37-10-3425			FED SINGLE					2.07	0.00
	41-10-3425			FED SINGLE					657.91	0.00
	42-10-3425			FED SINGLE					183.02	0.00
	42-22-3425			FED SINGLE					172.61	0.00
	43-22-3425			FED SINGLE					59.28	0.00
									<u>6531.34</u>	<u>0</u>
79580	1/24/2013	1/24/2013	4,707.36						EFTPS	ACH 575
	21-10-3435			SOC SECURITY					1,671.24	0.00
	22-10-3435			SOC SECURITY					1,767.26	0.00
	23-10-3435			SOC SECURITY					1,268.86	0.00
									<u>4707.36</u>	<u>0</u>
79581	1/24/2013	1/24/2013	1,100.98						EFTPS	ACH 576
	21-10-3435			MEDICARE		169			390.92	0.00
	22-10-3435			MEDICARE					413.28	0.00
	23-10-3435			MEDICARE					296.78	0.00
									<u>1100.98</u>	<u>0</u>

# Accounts Payable Detail Listing

CITY OF CRETE

<u>Pay#</u>	<u>Post Date</u>	<u>Due Date</u>	<u>Amount</u>	<u>Invoice</u>	<u>Date</u>	<u>PO#</u>	<u>Date</u>	<u>Vend#</u>	<u>Vendor Name</u>	<u>Status</u>
	<u>Account#</u>	<u>Work Order</u>			<u>Description</u>				<u>Debit</u>	<u>Credit</u>
79582	1/24/2013	1/24/2013	3,613.67						EFTPS	ACH 577
	21-10-3425				FED MARRIED				1,130.96	0.00
	22-10-3425				FED MARRIED				918.95	0.00
	23-10-3425				FED MARRIED				478.47	0.00
	21-10-3425				FED SINGLE				173.91	0.00
	22-10-3425				FED SINGLE				579.99	0.00
	23-10-3425				FED SINGLE				331.39	0.00
									<u>3613.67</u>	<u>0</u>
79602	2/5/2013	2/5/2013	2,224.73	119423					ELLIOTT EQUIPMENT CO	Posted
	23-10-8101				MAINT SEWER LINE EQUIP				2,224.73	0.00
79555	1/24/2013	1/24/2013	451.67						LIFE EMC NATIONAL LIFE COMPANck# 74848	Printed
	10-10-3445				CAFE LIFE				9.16	0.00
	10-30-3445				CAFE LIFE				4.89	0.00
	10-40-3445				CAFE LIFE				33.50	0.00
	10-60-3445				CAFE LIFE				5.78	0.00
	24-10-3445				CAFE LIFE				21.22	0.00
	31-21-3445				CAFE LIFE				1.08	0.00
	37-10-3445				CAFE LIFE				2.49	0.00
	39-10-3445				CAFE LIFE				5.83	0.00
	41-10-3445				CAFE LIFE				44.50	0.00
	42-10-3445				CAFE LIFE				15.33	0.00
	42-22-3445				CAFE LIFE				0.96	0.00
	43-10-3445				CAFE LIFE				0.04	0.00
	43-22-3445				CAFE LIFE				0.33	0.00
	10-10-5160				MO END LIFE				40.73	0.00
	10-30-5160				MO END LIFE				20.36	0.00
	10-40-5160				MO END LIFE				40.73	0.00
	10-60-5160				MO END LIFE				4.07	0.00
	24-10-5160				MO END LIFE				20.36	0.00
	37-10-5160				MO END LIFE				4.07	0.00
	41-10-5160				MO END LIFE				12.22	0.00
	42-10-5160				MO END LIFE				8.15	0.00
	42-22-5160				MO END LIFE				4.07	0.00
	31-10-5160				FIREMEN LIFE				151.80	0.00
									<u>451.67</u>	<u>0</u>
79556	1/24/2013	1/24/2013	24.84						LIFE EMC NATIONAL LIFE COMPANck# 74848	Printed
	10-10-3445				REG LIFE				1.75	0.00
	10-40-3445				REG LIFE				7.01	0.00
	24-10-3445				REG LIFE				2.74	0.00
	31-21-3445				REG LIFE				13.34	0.00
									<u>24.84</u>	<u>0</u>
79583	1/24/2013	1/24/2013	133.63						LIFE EMC NATIONAL LIFE COMPANck# 23108	Printed
	21-10-3445				CAFE LIFE				19.69	0.00
	22-10-3445				CAFE LIFE				51.95	0.00
	23-10-3445				CAFE LIFE				61.99	0.00
									<u>133.63</u>	<u>0</u>
79584	1/24/2013	1/24/2013	132.37						LIFE EMC NATIONAL LIFE COMPANck# 23108	Printed
	21-10-3445				REG LIFE				7.40	0.00
	22-10-3445				REG LIFE				6.01	0.00

# Accounts Payable Detail Listing

CITY OF CRETE

<u>Pay#</u>	<u>Post Date</u>	<u>Due Date</u>	<u>Amount</u>	<u>Invoice</u>	<u>Date</u>	<u>PO#</u>	<u>Date</u>	<u>Vend#</u>	<u>Vendor Name</u>	<u>Status</u>
	<u>Account#</u>	<u>Work Order</u>			<u>Description</u>				<u>Debit</u>	<u>Credit</u>
	23-10-3445				REG LIFE				2.21	0.00
	21-10-9620				MO END LIFE				48.87	0.00
	22-10-9620				MO END LIFE				40.73	0.00
	23-10-9620				MO END LIFE				27.15	0.00
									132.37	0
79710	2/5/2013	2/5/2013	365.45	1526036				273	EMERGENCY MEDICAL PROD	Posted
	31-21-5341				MEDICAL SUPPLIES				365.45	0.00
79758	2/5/2013	2/5/2013	6,158.33	20130488					EMS BILLING SERVICES INC	Posted
	31-21-5340				RESCUE BILLING				2,925.77	0.00
	31-21-4045				RESCUE BILLING				0.00	14.99
	10-20-5340				TRANSFER BILLING				3,247.55	0.00
									6173.32	14.99
79731	2/5/2013	2/5/2013	64.00	684 W57951					DOR FARMERS CO-OPERATIVE	Posted
	10-40-5810				CHAINS				64.00	0.00
79687	2/4/2013	2/4/2013	100.00						FBINAA - NE CHAPTER	Ck# 74853 Printed
	10-40-5470				MTG & TRNG				100.00	0.00
79707	2/5/2013	2/5/2013	1,435.68	0000051558					FIREGUARD INC.	Posted
	32-10-5261				COATS/BOOTS/HELMETS/GLOVES				1,435.68	0.00
79616	1/28/2013	1/28/2013	28.82						FIRST NAT'N'L BANK OF OMAH	Ck# 74846 Printed
	10-40-5120				RECRUITMENT				15.70	0.00
	10-40-5970				MISC OP				13.12	0.00
									28.82	0
79559	1/24/2013	1/24/2013	1,387.51					611	FIRST NEBRASKA EDUCATORACH	20101374
	10-10-3415				CREDIT UNION				27.38	0.00
	10-30-3415				CREDIT UNION				75.00	0.00
	10-40-3415				CREDIT UNION				200.00	0.00
	24-10-3415				CREDIT UNION				75.13	0.00
	41-10-3415				CREDIT UNION				1,000.00	0.00
	42-22-3415				CREDIT UNION				7.44	0.00
	43-22-3415				CREDIT UNION				2.56	0.00
									1387.51	0
79585	1/24/2013	1/24/2013	412.49					611	FIRST NEBRASKA EDUCATORACH	578
	21-10-3415				CREDIT UNION				209.94	0.00
	22-10-3415				CREDIT UNION				160.19	0.00
	23-10-3415				CREDIT UNION				42.36	0.00
									412.49	0
79574	1/24/2013	1/24/2013	385.00						FOP LODGE #74	ACH 20101375
	10-30-3477				FOP DUES				113.37	0.00
	10-40-3477				FOP DUES				265.00	0.00
	31-21-3477				FOP DUES				6.63	0.00
									385	0
79642	2/5/2013	2/5/2013	2,200.00	34661				86	GILMORE & ASSOCIATES INC	Posted
	23-10-2149				CS-1794 SURVEY				2,200.00	0.00
79732	2/5/2013	2/5/2013	64.00						GREAT WESTERN BANK	Posted
	10-40-5660				SPEC INV				64.00	0.00
79670	2/5/2013	2/5/2013	45.44	8110162			171		HACH COMPANY CO	Posted
	22-10-7041				TREATMT SUPPLIES				45.44	0.00
79675	2/5/2013	2/5/2013	317.67	12842				446	HAMILTON EQUIPMENT CO.	Posted

# Accounts Payable Detail Listing

CITY OF CRETE

<u>Pay#</u>	<u>Post Date</u>	<u>Due Date</u>	<u>Amount</u>	<u>Invoice</u>	<u>Date</u>	<u>PO#</u>	<u>Date</u>	<u>Vend#</u>	<u>Vendor Name</u>	<u>Status</u>
	<u>Account#</u>	<u>Work Order</u>			<u>Description</u>				<u>Debit</u>	<u>Credit</u>
79664	24-10-5951		175.94		EQUIP PARTS				317.67	0.00
79664	2/5/2013	2/5/2013						NP HAMPTON INN NORTH PLATTE		Posted
79757	21-10-9760		7,476.01		MTG & TRNG				175.94	0.00
79757	2/5/2013	2/5/2013						HARDING & SHULTZ, P.C.,L.L.C.		Posted
79715	10-10-5384		35.00	3429965	CONTRACT NEG				7,476.01	0.00
79715	2/5/2013	2/5/2013						HAWKINS, INC		Posted
79703	22-10-7041		152.26	336748-00	TREATMT SUPPLIES				35.00	0.00
79703	2/5/2013	2/5/2013						HUSKER ELECTRIC SUPPLY C		Posted
79730	23-10-7201		120.00		FUSE				152.26	0.00
79730	2/5/2013	2/5/2013						INT'L ASSN OF CHIEFS OF POI		Posted
79634	10-40-5400		25,581.97	5529	DUES & MEMBERSHIPS				120.00	0.00
79634	2/5/2013	2/5/2013						INTEGRATED SYSTEMS GRO		Posted
	21-10-1826				SECURITY EQUIP				23,908.38	0.00
	21-10-1826				TAX ADDED				1,673.59	0.00
									<u>25581.97</u>	<u>0</u>
79754	2/5/2013	2/5/2013	60.00	56036	CLEANING SOL			117 JAY'S OIL CO.	60.00	0.00
79641	24-10-5970		1,289.80	71633	R121273.00 WELLHEAD PROT				1,289.80	0.00
79641	2/5/2013	2/5/2013						JEO CONSULTING GROUP, IN		Posted
79614	22-10-9920		501.74	216585-00	POLICE CRUISERS				501.74	0.00
79614	2/5/2013	2/5/2013						JONES AUTOMOTIVE		Posted
79552	61-10-6420		259.50		INMATE CASH RETURN				259.50	0.00
79552	1/22/2013	1/22/2013						KYLE GREEN #718715		Ck# 74839 Printed
79615	2/5/2013	2/5/2013	30.15	5266-68414	VEHICLE REPAIRS				30.15	0.00
79615	2/5/2013	2/5/2013						L & L AUTO PARTS		Posted
79645	24-10-5921		29.95	5266-67762	TRUCK PARTS				29.95	0.00
79645	2/5/2013	2/5/2013						L & L AUTO PARTS		Posted
79601	31-21-5170		481.00	1040	AUTO INS				860.00	0.00
79601	2/5/2013	2/5/2013						LEAGUE ASSOC OF RISK MAN		Posted
	31-21-5170				AUTO INS				0.00	379.00
									<u>860</u>	<u>379</u>
79627	2/5/2013	2/5/2013	28.50		MTG & TRNG				28.50	0.00
79610	23-10-9760		450.00	97750	RECRUITMENT				450.00	0.00
79610	2/5/2013	2/5/2013						LINCOLN ORTHOPEDIC PHYSI		Posted
79656	22-10-1700		250.42	023069 00	DIST SYST/REMEDI/REBUILD				75.36	0.00
79656	2/5/2013	2/5/2013						LINCOLN WINWATER WORKS		Posted
	23-10-8032				MAINT OF LATERALS				175.06	0.00
									<u>250.42</u>	<u>0</u>
79755	2/5/2013	2/5/2013	129.32	023289 00	DIST SYST/REMEDI/REBUILD				129.32	0.00
79755	2/5/2013	2/5/2013						LINCOLN WINWATER WORKS		Posted
79669	10-40-5382		20.00		INTERPRET				20.00	0.00
79669	2/5/2013	2/5/2013						MANUEL DIMAS		Posted
79544	41-10-5210		28.45		UTIL				28.45	0.00
79544	1/17/2013	1/17/2013						MCI MEGA PREFERRED		Ck# 74831 Printed
79649	23-10-7282		21.26	5289321	LAB		172		21.26	0.00
79649	2/5/2013	2/5/2013						1050 MIDLAND SCIENTIFIC, INC		Posted
79716	23-10-7282		21.92	5290013	LAB				21.92	0.00
79716	2/5/2013	2/5/2013						1050 MIDLAND SCIENTIFIC, INC		Posted

# Accounts Payable Detail Listing

CITY OF CRETE

<u>Pay#</u>	<u>Post Date</u>	<u>Due Date</u>	<u>Amount</u>	<u>Invoice</u>	<u>Date</u>	<u>PO#</u>	<u>Date</u>	<u>Vend#</u>	<u>Vendor Name</u>	<u>Status</u>
	<u>Account#</u>	<u>Work Order</u>			<u>Description</u>				<u>Debit</u>	<u>Credit</u>
79630	2/5/2013	2/5/2013	5,723.25	0522711-IN				224	MUNICIPAL SUPPLY INC. OF N	Posted
	22-10-1700				FIRE HYDRANTS				5,723.25	0.00
79631	2/5/2013	2/5/2013	3,815.50	0522712-IN				224	MUNICIPAL SUPPLY INC. OF N	Posted
	22-10-1700				FIRE HYDRANTS				3,815.50	0.00
79632	2/5/2013	2/5/2013	1,642.12	0522713-IN				224	MUNICIPAL SUPPLY INC. OF N	Posted
	22-10-1700				DIST SYST/REMEDI/REBUILD				1,642.12	0.00
79718	2/5/2013	2/5/2013	20.00							
	10-40-5382				INTERPRET				20.00	0.00
79600	2/5/2013	2/5/2013	5.42	858254				176	NAPA AUTO PARTS	Posted
	21-10-8460				VEHICLE PARTS				5.42	0.00
79633	2/5/2013	2/5/2013	262.23	868621				176	NAPA AUTO PARTS	Posted
	23-10-8101				MAINT SEWER LINE/EQUIP				262.23	0.00
79719	2/5/2013	2/5/2013	170.46	857892				176	NAPA AUTO PARTS	Posted
	24-10-5936				DUMP TRUCK PARTS				170.46	0.00
79720	2/5/2013	2/5/2013	31.65	857393				176	NAPA AUTO PARTS	Posted
	24-10-5903				P U PARTS				31.65	0.00
79721	2/5/2013	2/5/2013	35.28	857381				176	NAPA AUTO PARTS	Posted
	24-10-5903				P U PARTS				35.28	0.00
79722	2/5/2013	2/5/2013	67.98	857016				176	NAPA AUTO PARTS	Posted
	24-10-5946				FUEL FILTER				67.98	0.00
79723	2/5/2013	2/5/2013	324.80	857015				176	NAPA AUTO PARTS	Posted
	24-10-5921				DUMP TRUCK PARTS				324.80	0.00
79724	2/5/2013	2/5/2013	51.23	858456				176	NAPA AUTO PARTS	Posted
	21-10-7200				MAINT AUX EQUIP				51.23	0.00
79725	2/5/2013	2/5/2013	18.36	857199				176	NAPA AUTO PARTS	Posted
	21-10-8100				MAINT EQUIP/MAT				18.36	0.00
79726	2/5/2013	2/5/2013	35.73	858813				176	NAPA AUTO PARTS	Posted
	23-10-7460				VEHICLE EXP				35.73	0.00
79727	2/5/2013	2/5/2013	38.96	858808				176	NAPA AUTO PARTS	Posted
	23-10-7460				TRUCK PARTS				38.96	0.00
79728	2/5/2013	2/5/2013	9.58	858820				176	NAPA AUTO PARTS	Posted
	42-10-5801				VEH/EQUIP/OIL & GREASE				9.58	0.00
79749	2/5/2013	2/5/2013	16.98	857317				176	NAPA AUTO PARTS	Posted
	24-10-5903				SNOW PLOW PARTS				16.98	0.00
79750	2/5/2013	2/5/2013	289.00	857598				176	NAPA AUTO PARTS	Posted
	24-10-5903				SNOW PLOW PARTS				289.00	0.00
79570	1/24/2013	1/24/2013	300.00							
	10-10-3475				CHILD SUPPORT				300.00	0.00
79586	1/24/2013	1/24/2013	132.01							
	22-10-3475				CHILD SUPPORT				132.01	0.00
79565	1/24/2013	1/24/2013	2,136.44							
	10-10-3430				ST MARRIED				139.71	0.00
	10-20-3430				ST MARRIED				0.31	0.00
	10-30-3430				ST MARRIED				81.25	0.00
	10-40-3430				ST MARRIED				241.22	0.00
	24-10-3430				ST MARRIED				250.11	0.00
	31-10-3430				ST MARRIED				0.76	0.00
	31-21-3430				ST MARRIED				28.07	0.00
	37-10-3430				ST MARRIED				12.23	0.00
	39-10-3430				ST MARRIED				7.92	0.00



# Accounts Payable Detail Listing

CITY OF CRETE										
<u>Pay#</u>	<u>Post Date</u>	<u>Due Date</u>	<u>Amount</u>	<u>Invoice</u>	<u>Date</u>	<u>PO#</u>	<u>Date</u>	<u>Vend#</u>	<u>Vendor Name</u>	<u>Status</u>
	<u>Account#</u>	<u>Work Order</u>			<u>Description</u>				<u>Debit</u>	<u>Credit</u>
	24-10-5801				OIL ANTIFREEZE ETC				172.41	0.00
	42-10-5970				SCRAPER				9.49	0.00
	42-10-5332				BLDG/GROUNDS MAINT				8.56	0.00
									<u>205.7</u>	<u>0</u>
79712	2/5/2013	2/5/2013	31.64					218	TOM OURADA	Posted
	21-10-9760				MTG/TRNG				31.64	0.00
79752	2/5/2013	2/5/2013	515.92	28005				246	OVERHEAD DOOR CO.	Posted
	24-10-5330				BLDG & GROUND MAINT				515.92	0.00
79553	1/24/2013	1/24/2013	1.82					104	PINNACLE BANK	ACH 20101378
	42-10-3418				CHECKING ACH				0.91	0.00
	43-10-3418				CHECKING ACH				0.91	0.00
									<u>1.82</u>	<u>0</u>
79554	1/24/2013	1/24/2013	292.44					104	PINNACLE BANK	ACH 20101379
	10-30-3417				SAVINGS ACH				50.00	0.00
	10-40-3417				SAVINGS ACH				120.00	0.00
	42-10-3417				SAVINGS ACH				1.22	0.00
	42-22-3417				SAVINGS ACH				89.32	0.00
	43-10-3417				SAVINGS ACH				1.22	0.00
	43-22-3417				SAVINGS ACH				30.68	0.00
									<u>292.44</u>	<u>0</u>
79588	1/24/2013	1/24/2013	148.18					104	PINNACLE BANK	ACH 581
	21-10-3418				CHECKING ACH				148.18	0.00
79589	1/24/2013	1/24/2013	197.56					104	PINNACLE BANK	ACH 582
	21-10-3417				SAVINGS ACH				197.56	0.00
79590	1/24/2013	1/24/2013	770.32					104	PINNACLE BANK	ACH 583
	21-10-3465				DISABILITY INS				271.34	0.00
	22-10-3465				DISABILITY INS				288.84	0.00
	23-10-3465				DISABILITY INS				210.14	0.00
									<u>770.32</u>	<u>0</u>
79611	2/5/2013	2/5/2013	50.96	30018008				664	PRESTO-X COMPANY	Posted
	10-40-5329				GEN MAINT/REPAIR				50.96	0.00
79538	1/17/2013	1/17/2013	908.01					NEW	QUILL CORP.	Ck# 74834 Printed
	41-10-6210				PROGRAM				23.98	0.00
	41-10-5530				OFFICE SUPPLIES				573.39	0.00
	41-10-5541				JANITORIAL SUPPLIES				310.64	0.00
									<u>908.01</u>	<u>0</u>
79746	2/5/2013	2/5/2013	934.56						REVENUE FUNDS	Posted
	39-10-4850				24% GARBAGE CO FRANCHISE				934.56	0.00
79662	2/5/2013	2/5/2013	24.61					281	REVENUE/ELECTRIC FUND	Posted
	45-10-5541				P TOWELS				24.61	0.00
79697	2/5/2013	2/5/2013	11,474.30					CU	REVENUE/ELEC FUND CITY U	Posted
	21-10-7090				FUEL OIL RECOVERY				50.30	0.00
	21-10-9670				GAS PUMPS				47.88	0.00
	22-10-7100				WATER (4)				5,223.06	0.00
	23-10-7530				SEWER				6,153.06	0.00
									<u>11474.3</u>	<u>0</u>
						175				
79698	2/5/2013	2/5/2013	9,425.36					CU	REVENUE/ELEC FUND CITY U	Posted
	10-10-5490				GENERAL (2)				101.50	0.00



# Accounts Payable Detail Listing

CITY OF CRETE

<u>Pay#</u>	<u>Post Date</u>	<u>Due Date</u>	<u>Amount</u>	<u>Invoice</u>	<u>Date</u>	<u>PO#</u>	<u>Date</u>	<u>Vend#</u>	<u>Vendor Name</u>	<u>Status</u>
	<u>Account#</u>	<u>Work Order</u>			<u>Description</u>				<u>Debit</u>	<u>Credit</u>
	24-10-6020				MISC SUPPLIES				14.95	0.00
79676	1/31/2013	1/31/2013	24,437.00							
	10-10-6202				AREA TRANSIT				24,437.00	0.00
79537	1/17/2013	1/17/2013	1,055.19					154	SALINE COUNTY CLERK	Ck# 74835 Printed
	10-10-5970				ELECTION COSTS				1,055.19	0.00
79666	2/5/2013	2/5/2013	12.00					167	SALINE COUNTY COURT	Posted
	10-10-5420				COURT COSTS				12.00	0.00
79677	1/31/2013	1/31/2013	7,257.00							
	10-10-6206				SEN CITIZEN PROGRAMS				7,257.00	0.00
79751	2/5/2013	2/5/2013	113.00					1905	BRIAN SCHMIDT	Posted
	21-10-9760				MTG & TRNG				113.00	0.00
79618	1/28/2013	1/28/2013	89.04	5955322						
	40-10-5692				SPEC PROG				89.04	0.00
79704	2/5/2013	2/5/2013	1,579.58	14184						
	32-10-5270				RADIO REPLACEMENT				1,579.58	0.00
79708	2/5/2013	2/5/2013	162.30	14186						
	31-21-5970				MISC OP				162.30	0.00
79733	2/5/2013	2/5/2013	135.00	14211						
	17-10-5331				EQUIPMENT				135.00	0.00
79648	2/5/2013	2/5/2013	84.43	48368FR						
	23-10-7460				PICKUP REPAIR				84.43	0.00
79652	2/5/2013	2/5/2013	26.40	0022325				128	SKALA'S O.K. TIRE STORE, INC	Posted
	24-10-5947				TIRE REPAIR				26.40	0.00
79550	1/17/2013	1/17/2013	291.68							
	41-10-6040				COPIER LEASE				291.68	0.00
79729	2/5/2013	2/5/2013	46.56	8024424418						
	10-10-5530				OFFICE SUPPLIES				46.56	0.00
79711	2/5/2013	2/5/2013	27.12							
	10-10-5451				MILEAGE JAN				27.12	0.00
79547	1/17/2013	1/17/2013	23.60	35517				102	THE CRETE NEWS	Ck# 74837 Printed
	41-10-5390				CLASSIFIED AD				23.60	0.00
79548	1/17/2013	1/17/2013	8.80	35763				102	THE CRETE NEWS	Ck# 74837 Printed
	41-10-5390				LEGAL				8.80	0.00
79663	2/5/2013	2/5/2013	26.00					102	THE CRETE NEWS	Posted
	10-10-5390				SUBSCRIPTION				26.00	0.00
79747	2/5/2013	2/5/2013	267.53	1157095						
	10-40-5329				1945 FOREST				48.72	0.00
	16-10-5210				CITY HALL				137.65	0.00
	44-10-5210				1420 MAIN				17.41	0.00
	24-10-5330				212 E 15TH ST				63.75	0.00
									267.53	0
79748	2/5/2013	2/5/2013	260.59	1157095						
	21-10-8000				320 W 9TH ST				24.36	0.00
	22-10-8000				320 W 9TH ST				24.36	0.00
	23-10-7530				100 SOUTH MAIN				211.87	0.00
									260.59	0
79562	1/24/2013	1/24/2013	1,544.44							
	10-10-3465				DISABILITY INS				116.44	0.00
	10-30-3465				DISABILITY INS				156.65	0.00

# Accounts Payable Detail Listing

CITY OF CRETE

<u>Pay#</u>	<u>Post Date</u>	<u>Due Date</u>	<u>Amount</u>	<u>Invoice</u>	<u>Date</u>	<u>PO#</u>	<u>Date</u>	<u>Vend#</u>	<u>Vendor Name</u>	<u>Status</u>
	<u>Account#</u>	<u>Work Order</u>		<u>Description</u>					<u>Debit</u>	<u>Credit</u>
	10-40-3465			DISABILITY INS					424.47	0.00
	10-60-3465			DISABILITY INS					25.46	0.00
	24-10-3465			DISABILITY INS					225.07	0.00
	31-21-3465			DISABILITY INS					11.04	0.00
	37-10-3465			DISABILITY INS					10.46	0.00
	39-10-3465			DISABILITY INS					7.91	0.00
	41-10-3465			DISABILITY INS					130.04	0.00
	42-10-3465			DISABILITY INS					60.83	0.00
	42-22-3465			DISABILITY INS					41.09	0.00
	43-10-3465			DISABILITY INS					0.32	0.00
	43-22-3465			DISABILITY INS					14.01	0.00
	10-10-3465			MO END INS					22.58	0.00
	10-20-3465			MO END INS					0.92	0.00
	10-30-3465			MO END INS					43.65	0.00
	10-40-3465			MO END INS					112.78	0.00
	10-60-3465			MO END INS					8.82	0.00
	24-10-3465			MO END INS					46.58	0.00
	31-10-3465			MO END INS					1.34	0.00
	37-10-3465			MO END INS					15.86	0.00
	39-10-3465			MO END INS					2.80	0.00
	41-10-3465			MO END INS					38.67	0.00
	42-10-3465			MO END INS					14.33	0.00
	42-22-3465			MO END INS					8.91	0.00
	43-10-3465			MO END INS					0.33	0.00
	43-22-3465			MO END INS					3.08	0.00
									<u>1544.44</u>	<u>0</u>
79742	2/5/2013	2/5/2013	1,148.40					132	THE LAW OFFICE, P.C.	Posted
	21-10-9860			LEGAL SERV					382.80	0.00
	22-10-9860			LEGAL SERV					382.80	0.00
	23-10-9860			LEGAL SERV					382.80	0.00
									<u>1148.4</u>	<u>0</u>
79743	2/5/2013	2/5/2013	765.60					132	THE LAW OFFICE, P.C.	Posted
	10-10-5380			LEGAL SERV					382.80	0.00
	24-10-5380			LEGAL SERV					382.80	0.00
									<u>765.6</u>	<u>0</u>
79686	2/1/2013	2/1/2013	48.81						TIME WARNER CABLE	Posted
	21-10-9915			COMPUTER EXP					16.27	0.00
	22-10-9915			COMPUTER EXP					16.27	0.00
	23-10-9915			COMPUTER EXP					16.27	0.00
									<u>48.81</u>	<u>0</u>
79688	2/5/2013	2/5/2013	118.59						TIME WARNER CABLE	Posted
	31-10-5790			COMPUTER EXP					12.04	0.00
	10-10-5790			COMPUTER EXP					23.97	0.00
	10-40-5790			COMPUTER EXP					34.00	0.00
	24-10-5790			COMPUTER EXP					5.02	0.00
	41-10-6050			COMPUTER EXP		178			38.54	0.00
	42-22-5790			COMPUTER EXP					5.02	0.00
									<u>118.59</u>	<u>0</u>

# Accounts Payable Detail Listing

CITY OF CRETE										
<u>Pay#</u>	<u>Post Date</u>	<u>Due Date</u>	<u>Amount</u>	<u>Invoice</u>	<u>Date</u>	<u>PO#</u>	<u>Date</u>	<u>Vend#</u>	<u>Vendor Name</u>	<u>Status</u>
	<u>Account#</u>	<u>Work Order</u>			<u>Description</u>				<u>Debit</u>	<u>Credit</u>
79624	2/5/2013	2/5/2013	600.00						TOTALFUNDS BY HASLER	Posted
	10-10-5970				POSTAGE				350.00	0.00
	24-10-5970				POSTAGE				50.00	0.00
	41-10-6030				POSTAGE				50.00	0.00
	42-22-5970				POSTAGE				150.00	0.00
									600	0
79625	2/5/2013	2/5/2013	400.00						TOTALFUNDS BY HASLER	Posted
	21-10-9650				POSTAGE				300.00	0.00
	22-10-9650				POSTAGE				50.00	0.00
	23-10-9650				POSTAGE				50.00	0.00
									400	0
79680	2/5/2013	2/5/2013	415.17						TOM U.S. BANK	Posted
	23-10-7470				MTG & TRNG				236.04	0.00
	21-10-8500				MISC OP				44.19	0.00
	22-10-8500				MISC OP				44.19	0.00
	23-10-9670				MISC OP				44.19	0.00
	21-10-9915				COMPUTERS				24.50	0.00
	22-10-9915				COMPUTERS				24.50	0.00
	23-10-9915				COMPUTERS				24.49	0.00
	23-10-7470				MTG & TRNG				0.00	26.93
									442.1	26.93
79681	2/5/2013	2/5/2013	24.49						TOM U.S. BANK	Posted
	24-10-5970				CC PURCHASES				24.49	0.00
79682	2/5/2013	2/5/2013	47.75						CLERK U.S. BANK	Posted
	10-10-5384				CONTRACT NEG				18.82	0.00
	10-10-5970				MISC OP				2.00	0.00
	10-10-5970				MISC OP				26.93	0.00
									47.75	0
79622	2/5/2013	2/5/2013	18.89	220425888					U.S. BANK EQUIPMENT FINAN	Posted
	10-10-5780				COPIER LEASE/FAX				18.89	0.00
79678	2/5/2013	2/5/2013	162.94	2210000383					U.S. BANK EQUIPMENT FINAN	Posted
	10-10-5780				COPIER LEASE				87.83	0.00
	10-40-5780				COPIER LEASE				24.70	0.00
	42-22-5780				COPIER LEASE				24.70	0.00
	24-10-5351				COPIER LEASE				25.71	0.00
									162.94	0
79679	2/5/2013	2/5/2013	107.50	221000383					U.S. BANK EQUIPMENT FINAN	Posted
	21-10-9740				COPIER LEASE				51.43	0.00
	22-10-9740				COPIER LEASE				25.71	0.00
	23-10-9740				COPIER LEASE				25.71	0.00
	21-10-9740				COPIER LEASE TAX ADDED				3.10	0.00
	22-10-9740				COPIER LEASE TAX ADDED				1.55	0.00
									107.5	0
79563	1/24/2013	1/24/2013	6,755.92						UNION BANK & TRUST CO	ACH 20101380
	10-10-3470				PENSION 6%				681.32	0.00
	10-30-3470				PENSION 6%	179			876.28	0.00
	10-60-3470				PENSION 6%				149.56	0.00
	24-10-3470				PENSION 6%				1,158.04	0.00

# Accounts Payable Detail Listing

CITY OF CRETE

<u>Pay#</u>	<u>Post Date</u>	<u>Due Date</u>	<u>Amount</u>	<u>Invoice</u>	<u>Date</u>	<u>PO#</u>	<u>Date</u>	<u>Vend#</u>	<u>Vendor Name</u>	<u>Status</u>
	<u>Account#</u>	<u>Work Order</u>			<u>Description</u>				<u>Debit</u>	<u>Credit</u>
	37-10-3470				PENSION 6%				51.94	0.00
	39-10-3470				PENSION 6%				42.66	0.00
	41-10-3470				PENSION 6%				784.90	0.00
	42-10-3470				PENSION 6%				331.90	0.00
	42-22-3470				PENSION 6%				221.14	0.00
	43-10-3470				PENSION 6%				1.72	0.00
	43-22-3470				PENSION 6%				73.72	0.00
	10-40-3470				PD PENSION 6%				2,382.74	0.00
									<u>6755.92</u>	<u>0</u>
79564	1/24/2013	1/24/2013	258.22							
	10-10-3471				DEF COMP				75.00	0.00
	10-30-3471				DEF COMP				26.59	0.00
	10-40-3471				DEF COMP				70.00	0.00
	24-10-3471				DEF COMP				36.63	0.00
	39-10-3471				DEF COMP				8.77	0.00
	42-10-3471				DEF COMP				21.23	0.00
	42-22-3471				DEF COMP				14.89	0.00
	43-22-3471				DEF COMP				5.11	0.00
									<u>258.22</u>	<u>0</u>
79591	1/24/2013	1/24/2013	3,869.34							
	21-10-3470				PENSION 6%				1,420.76	0.00
	22-10-3470				PENSION 6%				1,383.70	0.00
	23-10-3470				PENSION 6%				1,064.88	0.00
									<u>3869.34</u>	<u>0</u>
79592	1/24/2013	1/24/2013	113.37							
	21-10-3471				DEF COMP				113.37	0.00
79647	2/5/2013	2/5/2013	45.00							
	42-10-5470				MTG & TRNG			TREES UNIV OF NE	45.00	0.00
79639	2/5/2013	2/5/2013	155.45	0000R56414033						
	24-10-6000				SHIPPING			UPS	91.84	0.00
	24-10-6000				SHIPPING				63.61	0.00
									<u>155.45</u>	<u>0</u>
79640	2/5/2013	2/5/2013	15.64	0000R56414033						
	21-10-9915				SHIPPING			UPS	7.53	0.00
	21-10-1826				SHIPPING				8.11	0.00
									<u>15.64</u>	<u>0</u>
79744	2/5/2013	2/5/2013	427.09							
	24-10-5970				UTIL			VERIZON WIRELESS	94.99	0.00
	10-10-5452				UTIL				28.96	0.00
	42-22-5970				UTIL				59.88	0.00
	31-10-5210				UTIL				117.91	0.00
	10-40-5220				UTIL				125.35	0.00
									<u>427.09</u>	<u>0</u>
79745	2/5/2013	2/5/2013	292.55							
	21-10-9660				UTIL			VERIZON WIRELESS	177.02	0.00
	22-10-9660				UTIL	180			82.24	0.00
	23-10-9660				UTIL				33.29	0.00
									<u>292.55</u>	<u>0</u>

# Accounts Payable Detail Listing

CITY OF CRETE

<u>Pay#</u>	<u>Post Date</u>	<u>Due Date</u>	<u>Amount</u>	<u>Invoice</u>	<u>Date</u>	<u>PO#</u>	<u>Description</u>	<u>Date</u>	<u>Vend#</u>	<u>Vendor Name</u>	<u>Debit</u>	<u>Credit</u>	<u>Status</u>
79594	2/5/2013	2/5/2013	41.38	0608692			UNIFORMS		532	WALKERS UNIFORM RENTAL	41.38	0.00	Posted
	23-10-9640												
79628	2/5/2013	2/5/2013	41.38	0609925			UNIFORMS		532	WALKERS UNIFORM RENTAL	41.38	0.00	Posted
	23-10-9640												
79714	2/5/2013	2/5/2013	41.38	0611174			UNIFORMS		532	WALKERS UNIFORM RENTAL	41.38	0.00	Posted
	23-10-9640												
79657	2/5/2013	2/5/2013	524.97	119673			STREET LIGHTS			WESCO RECEIVABLES CORP	524.97	0.00	Posted
	24-10-5905												
79756	2/5/2013	2/5/2013	840.00	120823			ST LIGHT MAINT			WESCO RECEIVABLES CORP	840.00	0.00	Posted
	24-10-5905												
79546	1/17/2013	1/17/2013	44.29				UTIL		3E!!!!!!!!!!!!	WINDSTREAM	44.29	0.00	Ck# 74838 Printed
	41-10-5210												
79609	2/5/2013	2/5/2013	27.48				UTIL		3E!!!!!!!!!!!!	WINDSTREAM	27.48	0.00	Posted
	43-22-5970												
79635	2/5/2013	2/5/2013	259.45				MTG & TRNG			JOHN WIRUTH	259.45	0.00	Posted
	23-10-9760												
79668	2/5/2013	2/5/2013	20.00				INTERPRET			ZORAIDA RAMOS	20.00	0.00	Posted
	10-40-5382												
79717	2/5/2013	2/5/2013	60.00				INTERPRET			ZORAIDA RAMOS	60.00	0.00	Posted
	10-40-5382												
			<b>280,756.97</b>	221 Non-voided payables listed.									

Report Setup  
 AP - Accounts Payable Listing : Vendor Name  
 Filter Options  
 Starting: 1/16/2013  
 Ending: 2/5/2013  
 Banks: All  
 Payable Status: Posted, Printed, ACH, Recorded, Voided  
 All Vendors Selected