

## Committee As A Whole

**Mission:** "Engaging All Learners to Achieve Success"

The Committee As A Whole started at 5:30 PM on Monday, May 11, 2026. The meeting was held at Kramer Education Center  
2410 16th Street, Suite A  
Columbus, NE 68601

Candace Becher: Absent

Michael Jeffryes: Present

Doug Molczyk: Absent

Theresa Seipel: Present

Douglas Willoughby: Present

Marv Zoucha: Present

I. CALL TO ORDER

II. ROLL CALL OF THE BOARD

III. EXCUSE BOARD MEMBERS

Motion to excuse board members. Passed with a motion by Michael Jeffryes and a second by Marv Zoucha.

Michael Jeffryes: Yea, Theresa Seipel: Yea, Douglas Willoughby: Yea, Marv Zoucha: Yea

IV. PLEDGE OF ALLEGIANCE

V. MEETING COMPLIANCE

V.A. DISTRICT MISSION STATEMENT

V.B. OPEN MEETINGS ACT

V.B.1. President ensures all can hear proceedings

V.C. PUBLICATION OF MEETING NOTICE

VI. RECOGNITIONS BY BOARD

VI.A. Quiz Bowl State Qualifiers

VII. PUBLIC COMMENT

VIII. GUEST PRESENTATIONS

IX. BUILDING OR DISTRICT PRESENTATION

X. CONSENT AGENDA

X.A. Items to be removed from the Consent Agenda

X.B. Meeting Minutes

X.C. Finance Reports

Jason Schapmann, Director of Human Resources and Fiscal Support shared information on all financial reports. He said the Nutrition Fund is currently even with LunchTime Solutions. He explained the Depreciation Fund and the projects taken out.

X.D. Staffing Reports

Mr. Schapmann said there are two positions open at this time. He said we do not hire classified staff at this time because of summer break. There was discussion about leave of absence. He said there is a two-year maximum for those requests.

X.E. Professional Travel

XI. FOUNDATION REPORT

Nicole Anderson, Foundation Director and Director of Communications, reported that the memo shows payments made for post-prom and the After School Program. \$15,884.90 for April; \$79,068.59 Year to Date.

## XII. DIRECTOR & SUPERINTENDENTS REPORTS OR UPDATES

### XII.A. Director of Teaching and Learning

Teresa Hausmann, Director of Teaching and Learning, shared that spring accountability testing is finished. She said the Family Literacy Program has shown great progress and has received a very favorable report. The Teaching and Learning Department had 292 touchpoints for the month of April.

#### XII.A.1. Columbus Family Literacy Program

### XII.B. Director of Special Education

### XII.C. Assistant Director for Student Services

### XII.D. Director of Human Resources

Mr. Schapmann shared the year to date expenditures by function report. He shared the progress of choosing a food service company.

### XII.E. Director of Operations

### XII.F. Superintendent

Dr. Chip Kay, Superintendent, said he would present the Strategic Plan at the meeting next week.

## XIII. MONTHLY REVIEW OF POLICIES

## XIV. DISCUSSION ITEMS

### XIV.A. Administrator Wage & Benefit Recommendation for 2026-2027

Dr. Kay commented on the administrator's wage and compensation recommendation. He said 21 employees are compensated. The recommendation is 2.95%, which is not applied uniformly. Dr. Kay said he tried to keep it close to the teachers' percentage. He also said that they have the hardest jobs in the district, and they are deserving of compensation.

### XIV.B. Presence Contract for 2026-2027

Dr. Jason Harris discussed the Presence Contract. This is for online speech services. The school psychologist position has been filled. The contract helps to serve 485 students. \$85.00/hour X 36 weeks. Dr. Harris said this is the equivalent of 11 people for 188 days. If a student is absent, the session is made up. Students receive 40 minutes a week. They also provide evaluations for buildings.

### XIV.C. B.I.S.T. Service Agreement for 2026-2027

Dr. Harris talked about the BIST Agreement. He said this is how we manage tier 2 behaviors. Dr. Harris said this is our 7th year with BIST. They give CPS 5 consultation days. New this year is K-8 switching to BIST tier 1 and tier 2. Classroom teachers will be trained

this summer. High school has chosen to use Well Managed classrooms and one other program.

XIV.D. CMS Grease Trap Replacement

The grease trap at CMS has a leak. Discussion about an inspection process going forward.

XIV.E. CMS Raised Planters-Removal and Replacement of Concrete

CMS planters are falling apart. They will remove the planters and put in flat concrete. This is a more sustainable option.

XIV.F. District Wireless/Network Upgrade from CDWG

The district wireless upgrade is a summer project. Seventy five percent is paid by Erate. This project is a necessity. Erate is a federal program to make sure schools have connectivity.

XIV.G. Surplus

XIV.H. Fundraising Applications

XIV.I. Discoverer Bands Trip Request

XV. ACTION ITEMS FOR THIS MEETING

XV.A. First Reading of Policy 504.07R1 Student Activism-Protests, Walkouts, and Demonstrations

Motion to approve the First Reading of Policy 504.07R1 Student Activism-Protests, Walkouts, and Demonstrations Passed with a motion by Marv Zoucha and a second by Theresa Seipel.

Michael Jeffryes: Yea, Theresa Seipel: Yea, Douglas Willoughby: Yea, Marv Zoucha: Yea  
Dr. Kay talked about Policy 504.07R1 Student Activism. This policy gives CHS Administration some power to get students back into the building. The changes were not made to the policy, the regulation deals with walk out demonstrations.

XV.B. First Reading of Policy 502.09 In District Transfer including R1 and R2

Motion to approve first reading of policy 502.09, including R1 and R2 Passed with a motion by Douglas Willoughby and a second by Theresa Seipel.

Michael Jeffryes: Yea, Theresa Seipel: Yea, Douglas Willoughby: Yea, Marv Zoucha: Yea  
Dr. Kay said the form is part of the approval process. The big change is one transfer request is the limit. If there is a placement, that does not count towards the one transfer.

XV.C. First Reading of Policy 408.02 Certificated Employee Contract Release

Motion to approve the First Reading of Policy 408.02 Certificated Employee Contract Release, as submitted. Passed with a motion by Marv Zoucha and a second by Michael Jeffryes.

Michael Jeffryes: Yea, Theresa Seipel: Yea, Douglas Willoughby: Yea, Marv Zoucha: Yea

Mr. Schapmann talked about Policy 409.02 and the changes that have been made over the last several years. The later our date, the more people resign and the harder it is to replace them. Mr. Schapmann said this puts CPS at a disadvantage. There is still the superintendent's discretion.

XV.D. First Reading of Policy 402.22 Video Surveillance in the Workplace  
Motion to approve the First Reading of Policy 402.22 Video Surveillance, as submitted.  
Passed with a motion by Michael Jeffryes and a second by Douglas Willoughby.  
Michael Jeffryes: Yea, Theresa Seipel: Yea, Douglas Willoughby: Yea, Marv Zoucha: Yea

Dr. Kay discussed Policy 402.22 Video Surveillance in the Workplace. The policy states certain violations. There must be consent for audio recording. Dr. Kay has concerns that the policy is not being met. Video surveillance should not be for general monitoring. All information is included in the policy to be sure we are compliant. This policy is very comprehensive.

XV.E. Presentation of 2026 Graduation List  
Motion to approve the CHS Graduation List for 2026. Passed with a motion by Theresa Seipel and a second by Marv Zoucha.  
Michael Jeffryes: Yea, Theresa Seipel: Yea, Douglas Willoughby: Yea, Marv Zoucha: Yea

## XVI. BOARD REQUESTS FOR INFORMATION

## XVII. BOARD SHARING

## XVIII. EXECUTIVE SESSION

The board did not go into Executive Session.

## XIX. ADJOURN

Motion to adjourn Passed with a motion by Theresa Seipel and a second by Michael Jeffryes.

Michael Jeffryes: Yea, Theresa Seipel: Yea, Douglas Willoughby: Yea, Marv Zoucha: Yea

The meeting was adjourned at 7:23pm.

I, the undersigned, being the duly qualified Secretary for the School District No. 1 of Columbus, Nebraska, certify that the preceding is a true and correct copy of the minutes of the Regular School Board meeting of Monday, May 11, 2026.

---

President

---

Secretary

Regular Meeting  
Tuesday, April 14, 2026 5:30 PM Central

Kramer Education Center  
2410 16th Street, Suite A  
Columbus, NE 68601

Candace Becher: Present  
Michael Jeffries: Present  
Doug Molczyk: Present  
Theresa Seipel: Present  
Douglas Willoughby: Present  
Marv Zoucha: Present  
Present: 6.

#### I. CALL TO ORDER

#### II. ROLL CALL OF THE BOARD

#### III. EXCUSE BOARD MEMBERS

#### IV. PLEDGE OF ALLEGIANCE

#### V. MEETING COMPLIANCE

##### V.A. DISTRICT MISSION STATEMENT

##### V.B. OPEN MEETINGS ACT

V.B.1. President ensures all can hear proceedings

##### V.C. PUBLICATION OF MEETING NOTICE

#### VI. PUBLIC COMMENT

#### VII. GUEST PRESENTATIONS

#### VIII. RECOGNITIONS BY BOARD

##### VIII.A. Destination Imagination Team

#### IX. BUILDING OR DISTRICT PRESENTATION

##### IX.A. Columbus High School Presentation

Principal Dave Hiebner presented an overview of CHS operations, noting a total enrollment of 1,236 students. The student body demographics include 52% Free/Reduced Lunch, 16% English Learners (EL), and 13% Special Education (SP). Supported by a dedicated staff of 77 teachers and 14 certified non-teacher staff and 44 classified staff. The building maintained its "Good" AQuESTT classification. CHS has an 85.2% graduation rate, Mr. Hiebner emphasized a continued focus on reducing chronic absenteeism and achieving a building-wide proficiency goal of 73%.

Engagement and connection is done through parent newsletters and ParentSquare. Mr. Hiebner produces a weekly staff newsletter. CHS is staying engaged with non-traditional parent/student at monthly meetings.

Mr. Hiebner said he is proud of our STEM programming, which continues to evolve to meet the needs of the Columbus workforce. A special shout-out to our Career Coordinator, Clete Arasmith, for his incredible work in connecting our students with local professionals.

Data from the Senior Exit Survey suggests that students feel well-prepared and stated they had a positive learning experience at CHS.

## X. CONSENT AGENDA

### X.A. Items to be removed from the Consent Agenda

### X.B. Meeting Minutes

### X.C. Finance Reports

### X.D. Staffing Reports

### X.E. Professional Travel

Motion to approve the consent agenda Passed with a motion by Theresa Seipel and a second by Marv Zoucha.

Candace Becher: Yea, Michael Jeffryes: Yea, Doug Molczyk: Yea, Theresa Seipel: Yea, Douglas Willoughby: Yea, Marv Zoucha: Yea

Yea: 6, Nay: 0

## XI. FOUNDATION REPORT

The Superintendent recommends that the board approve the Foundation Report, as submitted. Passed with a motion by Marv Zoucha and a second by Candace Becher.

Candace Becher: Yea, Michael Jeffryes: Yea, Doug Molczyk: Yea, Theresa Seipel: Yea, Douglas Willoughby: Yea, Marv Zoucha: Yea

Yea: 6, Nay: 0

Chip Kay, Superintendent, shared the monthly and year to date totals:\$24,855.30; \$63,183.69. He also reminded the group about the Discoverers or Distinction Banquet on April 16, 2026.

## XII. DIRECTOR & SUPERINTENDENTS REPORTS OR UPDATES

### XII.A. Director of Teaching and Learning

Teresa Hausmann, Director of Teaching and Learning said her department had 233 touchpoints for the month. Mrs. Hausmann talked about the CKLA K-5 curriculum.

### XII.B. Director of Special Education

Jason Harris, Director of Special Education apprised the results from NDE review. This information included risk areas, strengths IEP documentation and weaknesses.

### XII.C. Assistant Director for Student Services

#### XII.D. Director of Human Resources

Jason Schapmann, Director of Human Resources and Fiscal Support, shared hires and resignation numbers. He said staff have until April 15th to sign contracts. Mr. Schapmann mentioned that New Teacher Days will be July 13-15, 2026. The RFP proposal meeting for food service and May 1st will be opening bids. He shared the Summer Lunch Program information. CPS will serve out of CHS, CMS and the Kramer Education Building. Mr. Schapmann talked about the Staff Engagement Survey results. The NASBO Conference is coming up, and some of the Business Department staff will be attending along with him and Dr. Kay.

#### XII.E. Director of Operations

#### XII.F. Superintendent

Dr. Kay shared his experience at the Military Leadership Training he attended, he said it was a unique experience. Dr. Kay reminded the board that there is not a meeting on April 20th. There will be a Committee Meeting on April 27th. April 30 is a JNW follow-up. Dr. Kay gave some legislative updates. He also mentioned the change in the school calendar for April 20th. Graduation is on May 17th at 3:00.

### XIII. MONTHLY REVIEW OF POLICIES

#### XIV. DISCUSSION ITEMS

##### XIV.A. Presentation of 2026 Graduation List

#### XV. ACTION ITEMS FOR THIS MEETING

##### XV.A. Fundraising Applications for Approval

Motion to approve the Fundraising Applications, as submitted. Passed with a motion by Douglas Willoughby and a second by Theresa Seipel.

Candace Becher: Yea, Michael Jeffryes: Yea, Doug Molczyk: Yea, Theresa Seipel: Yea, Douglas Willoughby: Yea, Marv Zoucha: Yea  
Yea: 6, Nay: 0

##### XV.B. Approval of the CPS K-4 Literacy Plan

Motion to approve the CPS K-4 Literacy Plan, as submitted. Passed with a motion by Candace Becher and a second by Theresa Seipel.

Candace Becher: Yea, Michael Jeffryes: Yea, Doug Molczyk: Yea, Theresa Seipel: Yea, Douglas Willoughby: Yea, Marv Zoucha: Yea  
Yea: 6, Nay: 0

##### XV.C. Approval of K-5 or K-6 Amplify Desmos Curriculum Resource Proposal.

Motion to approve the K-6 Amplify Desmos Curriculum Resource Proposal, as submitted. Passed with a motion by Douglas Willoughby and a second by Candace Becher.

Candace Becher: Yea, Michael Jeffryes: Yea, Doug Molczyk: Yea, Theresa Seipel: Yea, Douglas Willoughby: Yea, Marv Zoucha: Yea  
Yea: 6, Nay: 0

##### XV.D. Surplus Requests to be Approved

Motion to approve the Surplus Requests, as submitted. Passed with a motion by Theresa Seipel and a second by Marv Zoucha.

Candace Becher: Yea, Michael Jeffryes: Yea, Doug Molczyk: Yea, Theresa Seipel: Yea, Douglas Willoughby: Yea, Marv Zoucha: Yea  
Yea: 6, Nay: 0

XV.E. Approval for Carpet/LVT to be installed in additional rooms at West Park Elementary  
Motion to approve Carpet/LVT to be installed in additional rooms at West Park Elementary.

Passed with a motion by Candace Becher and a second by Marv Zoucha.

Candace Becher: Yea, Michael Jeffryes: Yea, Doug Molczyk: Yea, Theresa Seipel: Yea, Douglas Willoughby: Yea, Marv Zoucha: Yea  
Yea: 6, Nay: 0

XV.F. ServiceMaster Contract for 2026-2027

Motion to approve the 2026-2027 ServiceMaster Contract, as submitted. Passed with a motion by Doug Molczyk and a second by Michael Jeffryes.

Candace Becher: Yea, Michael Jeffryes: Yea, Doug Molczyk: Yea, Theresa Seipel: Yea, Douglas Willoughby: Yea, Marv Zoucha: Yea  
Yea: 6, Nay: 0

XV.G. Approval of Rutt's HVAC Contract for 2026-2031

Motion to approve The Rutt's HVAC Contract for 2026-2031, as submitted. Passed with a motion by Douglas Willoughby and a second by Michael Jeffryes.

Candace Becher: Yea, Michael Jeffryes: Yea, Doug Molczyk: Yea, Theresa Seipel: Yea, Douglas Willoughby: Yea, Marv Zoucha: Yea  
Yea: 6, Nay: 0

Leonard Kwapnioski, Director of Operations, discussed the Rutt's contract, he said they have been a long term partner. He has talked to a couple of other companies about bids, no one else is local. The contract is for 5 years, we pay on a yearly basis. It is basically 5 one-year contracts.

XV.H. 2026-2027 Projected Classified and Professional Hybrid Staffing Costs

Motion to approve the 2025-2026 Projected Classified and Professional Hybrid Staffing Costs. Passed with a motion by Theresa Seipel and a second by Douglas Willoughby.

Candace Becher: Yea, Michael Jeffryes: Yea, Doug Molczyk: Yea, Theresa Seipel: Yea, Douglas Willoughby: Yea, Marv Zoucha: Yea  
Yea: 6, Nay: 0

Mr. Schapmann gave the projected classified salary increase. He said it is higher than schools in the area but comparable to other schools our size. He noted, there are no food services listed on the salary schedule as we will not have food service employees any longer.

XV.I. Second Reading of Policy 405.02 Employee Obligation to Report Criminal Charges and Convictions

Motion to approve the Second Reading of Policy 405.02 Employee Obligation to Report Criminal Charges and Convictions. Passed with a motion by Doug Molczyk and a second by Candace Becher.

Candace Becher: Yea, Michael Jeffryes: Yea, Doug Molczyk: Yea, Theresa Seipel: Yea, Douglas Willoughby: Yea, Marv Zoucha: Yea  
Yea: 6, Nay: 0

XV.J. Second Reading of Policy 506.02 Student Organizations and 506.02R1 Student Clubs: Equal Access

Motions to approve the Second Reading of Policy 506.02 Student Organizations and 506.02R1 Student Clubs: Equal Access. Passed with a motion by Douglas Willoughby and a second by Marv Zoucha.

Candace Becher: Yea, Michael Jeffryes: Yea, Doug Molczyk: Yea, Theresa Seipel: Yea, Douglas Willoughby: Yea, Marv Zoucha: Yea  
Yea: 6, Nay: 0

#### XVI. BOARD REQUESTS FOR INFORMATION

#### XVII. BOARD SHARING

#### XVIII. EXECUTIVE SESSION

The board did not go into Executive Session

#### XIX. ADJOURN

Motion to adjourn Passed with a motion by Theresa Seipel and a second by Candace Becher.

Candace Becher: Yea, Michael Jeffryes: Yea, Doug Molczyk: Yea, Theresa Seipel: Yea, Douglas Willoughby: Yea, Marv Zoucha: Yea

Yea: 6, Nay: 0

The meeting was adjourned at 7:25pm.

I, the undersigned, being the duly qualified Secretary for the School District No. 1 of Columbus, Nebraska, certify that the preceding is a true and correct copy of the minutes of the Regular School Board meeting of Monday, April,

---

President

---

Secretary

Columbus Public Schools  
 Summary of Cash Balances  
 April 30, 2026

4	DESCRIPTION	BEGINNING BALANCE	MONTH TO DATE RECEIPTS	MONTH TO DATE EXPENDITURES	END OF MONTH BALANCE	YTD BALANCE PRIOR YEAR
General Fund	Attachment M4a			\$ 4,823,108.01		
	Attachment M5 (prior Bd Mtg)			\$ 333,395.04		
	Transfer to GP ICS Savings		\$(2,000,000.00)			
	Transfer <b>from</b> GP ICS Savings		\$ 7,000,000.00			
	Receipts GP checking		\$ 4,793,968.68			
	<b>GENERAL FUND - GREAT PLAINS STATE BANK</b>	\$ 5,542,509.90	\$ 9,793,968.68	\$ 5,156,503.05	\$ 10,179,975.53	\$ 9,631,425.79
	Transfer to GP Checking			\$ 7,000,000.00		
	Transfer <b>from</b> GP Checking		\$ 2,000,000.00			
	Interest		\$ 4,740.47			
	<b>GEN FUND - GP ICS SAVINGS</b>	\$ 6,968,908.54	\$ 2,004,740.47	\$ 7,000,000.00	\$ 1,973,649.01	\$ 1,505,563.85
	<b>General Fund - Cash Balance</b>				<b>\$ 12,153,624.54</b>	
Depreciation	Amazon Capital Services			\$ 288.07		
	Commonwealth Electric Midwest			\$ 40,000.00		
	Goodwin Tucker Group			\$ 320.44		
	Receipts					
	Interest		\$ 8,471.25			
	<b>DEPRECIATION - GREAT PLAINS STATE BANK</b>	\$ 3,326,011.68	\$ 8,471.25	\$ 40,608.51	\$ 3,293,874.42	\$ 986,955.82
Temporary Funds -GF	<b>PAYROLL - PINNACLE BANK</b>	\$ 443,497.84	\$ 3,994,497.40	\$ 3,938,125.41	\$ 499,869.83	\$ 417,132.87
	<b>HSA/FSA - PINNACLE BANK (Employee Benefit Fund)</b>	\$ 78,280.10	\$ 13,476.48	\$ 9,958.49	\$ 81,798.09	\$ 69,971.43
Activities	Administration	\$ 708,377.62	\$ 15,580.39	\$ 19,223.30	\$ 704,734.71	\$ 708,667.96
	Middle School	\$ 195,664.42	\$ 10,873.73	\$ 12,803.13	\$ 193,735.02	\$ 147,640.84
	High School	\$ 787,413.45	\$ 61,577.11	\$ 74,546.01	\$ 774,444.55	\$ 742,104.27
	<b>ACTIVITY FUNDS - COLUMBUS BANK</b>	\$ 1,691,455.49	\$ 88,031.23	\$ 106,572.44	\$ 1,672,914.28	\$ 1,598,413.07
Nutrition Fund	Attachment M6			\$ 306,559.39		
	Repayment of interfund Loan to General Fund			\$ 50,000.00		
	Interest Income		\$ 364.55			
	State Reimbursement		\$ 164,743.40			
	Rct to Expenditures		\$ 13,754.24			
	Student/ Staff meals/ a la carte sales		\$ 83,567.50			
	Fund transfer from General Fund		\$ 546,789.00			
	<b>NUTRITION FUND - CORNERSTONE BANK</b>	\$ 54,640.60	\$ 809,218.69	\$ 356,559.39	\$ 507,299.90	\$ 176,780.70
Bond Fund	Platte County Treasurer		\$ 268,137.70			
	Butler County Treasurer		\$ 30.39			
	Polk County Treasurer		\$ 1.99			
	Investment Gain		\$ 6,388.24			
	<b>BOND FUND - FNB</b>	\$ 2,431,650.65	\$ 274,558.32	\$ -	\$ 2,706,208.97	\$ 2,423,775.53
Building Fund	Platte County Treasurer			\$ 17,112.32		
	Rct to Expenditures					
	Receipts		\$ 142,703.35			
	<b>BLDG FUND - BANK OF THE VALLEY</b>	\$ 590,819.06	\$ 142,703.35	\$ 17,112.32	\$ 716,410.09	\$ 393,417.65
12- Student Fees Fund				\$ 0.00		
	Receipts		\$ 0.22			
	<b>STUDENT FEES FUND - ONE UNITED FEDERAL CREDIT UNION</b>	\$ 13,492.13	\$ 0.22	\$ 0.00	\$ 13,492.35	0

Columbus Public Schools  
 General Fund Revenue  
 April 30, 2026

Account Number	Description	Budget	Month to Date	Year to Date	Balance	Percent
01.1.01100.000.000	Property Taxes	(\$26,625,735.00)	(\$1,498,097.93)	(\$10,219,360.28)	(\$16,406,374.72)	38.38%
01.1.01115.000.000	Carline Taxes	(\$8,000.00)	\$0.00	(\$1,951.65)	(\$6,048.35)	24.40%
01.1.01120.000.000	Public Power District Sales Tax	(\$900,000.00)	\$0.00	\$0.00	(\$900,000.00)	0.00%
01.1.01125.000.000	Motor Vehicle Taxes	(\$1,145,000.00)	(\$230,223.16)	(\$1,643,069.48)	\$498,069.48	143.50%
01.1.01323.000.000	Tuition, SpEd School Age	(\$3,250.00)	\$0.00	\$0.00	(\$3,250.00)	0.00%
01.1.01510.000.000	Interest on Investments	(\$105,638.00)	(\$21,158.70)	(\$147,993.17)	\$42,355.17	140.09%
01.1.01911.000.000	Local License Fees	(\$25,000.00)	\$0.00	(\$17,772.50)	(\$7,227.50)	71.09%
01.1.01990.000.000	Miscellaneous Local Receipts	(\$20,000.00)	\$0.00	\$0.00	(\$20,000.00)	0.00%
01.1.02110.000.000	County Fines & License Fees	(\$161,000.00)	(\$19,476.84)	(\$143,905.02)	(\$17,094.98)	89.38%
01.1.02210.000.000	ESU Receipts	\$0.00	\$0.00	\$0.00	\$0.00	#DIV/0!
01.1.03110.000.000	State Aid	(\$18,156,653.00)	(\$1,803,103.00)	(\$14,550,443.00)	(\$3,606,210.00)	80.14%
01.1.03120.000.000	SpEd Receipts from the State	(\$6,500,000.00)	(\$896,165.00)	(\$4,725,657.00)	(\$1,774,343.00)	72.70%
01.1.03130.000.000	Homestead Exemption Allocation	\$0.00	(\$191,120.47)	(\$382,240.94)	\$382,240.94	#DIV/0!
01.1.03131.000.000	Property Tax Credit	\$0.00	\$0.00	(\$4,239,572.78)	\$4,239,572.78	#DIV/0!
01.1.03180.000.000	Pro-Rate Motor Vehicle	(\$32,000.00)	(\$35,772.55)	(\$57,334.45)	\$25,334.45	179.17%
01.1.03400.000.000	State Apportionment	(\$1,000,000.00)	\$0.00	(\$1,109,548.74)	\$109,548.74	110.95%
01.1.03535.000.000	High Ability Learners Allocation	(\$25,599.00)	\$0.00	(\$20,309.00)	(\$5,290.00)	79.34%
01.1.03540.000.000	State Early Childhood Grant	(\$130,730.00)	\$0.00	(\$194,467.00)	\$63,737.00	148.75%
01.1.03541.000.000	Early Childhood Endowment Grant	(\$174,500.00)	\$0.00	(\$106,898.00)	(\$67,602.00)	61.26%
01.1.03551.000.000	CTE Grant	\$0.00	\$0.00	(\$17,056.00)	\$17,056.00	#DIV/0!
01.1.03590.000.000	Extended Learning Opportunity	\$0.00	\$0.00	(\$1,423.04)	\$1,423.04	#DIV/0!
01.1.03599.000.000	State Categorical Programs	\$0.00	\$0.00	(\$1,500.00)	\$1,500.00	#DIV/0!
01.1.04505.000.000	ESSA Title I Part A: Improving	(\$700,176.00)	\$0.00	(\$389,619.00)	(\$310,557.00)	55.65%
01.1.04509.000.000	ESSA Title II Part A Supporting	(\$113,178.00)	\$0.00	(\$168,399.00)	\$55,221.00	148.79%
01.1.04510.000.000	ESSA Title IV Part A Student	(\$48,269.00)	\$0.00	\$0.00	(\$48,269.00)	0.00%
01.1.04516.000.000	IDEA Preschool Enrollment/Poverty	(\$25,599.00)	\$0.00	(\$25,237.00)	(\$362.00)	98.59%
01.1.04518.000.000	IDEA Part B (611) Base Enrollment	(\$1,350,000.00)	\$0.00	(\$1,346,396.00)	(\$3,604.00)	99.73%
01.1.04521.000.000	IDEA Part-B Proportionate Share	(\$164,500.00)	\$0.00	(\$144,379.00)	(\$20,121.00)	87.77%
01.1.04525.000.000	Carl Perkins Grants	(\$41,471.00)	\$0.00	(\$49,309.00)	\$7,838.00	118.90%
01.1.04527.000.000	ESSA Title III Part A English	(\$96,146.00)	\$0.00	(\$48,355.00)	(\$47,791.00)	50.29%
01.1.04528.000.000	ESSA Title III Immigrant	(\$28,744.00)	\$0.00	(\$35,112.00)	\$6,368.00	122.15%
01.1.04531.000.000	ESSA Title IV Part B 21st Century	(\$117,000.00)	\$0.00	(\$81,066.00)	(\$35,934.00)	69.29%
01.1.04708.000.000	Medicaid in Public Schools	(\$164,500.00)	(\$13,641.44)	(\$122,772.96)	(\$41,727.04)	74.63%
01.1.04709.000.000	Medicaid Administrative Activity	\$0.00	\$0.00	(\$13,812.27)	\$13,812.27	#DIV/0!
01.1.04969.000.000	ESSA Title IV-A Student Support	\$0.00	\$0.00	(\$41,853.00)	\$41,853.00	#DIV/0!
01.1.04991.000.000	McKinney-Vento Grant	\$0.00	\$0.00	\$0.00	\$0.00	#DIV/0!
01.1.05200.000.000	Transfers from Other Funds	\$0.00	\$0.00	\$0.00	\$0.00	#DIV/0!
01.1.05300.000.000	Proceeds from Disposal of Real or Personal Property	\$0.00	(\$27,490.00)	(\$27,490.00)	\$27,490.00	#DIV/0!
01.1.05690.000.000	Other Non-Revenue Receipts	\$0.00	\$0.00	\$0.00	\$0.00	#DIV/0!
01.1.09001.000.000	Repayment of Interfund Loan from the General Fund	\$0.00	(\$50,000.00)	(\$50,000.00)	\$50,000.00	#DIV/0!
		(\$57,862,688.00)	(\$4,786,249.09)	(\$40,124,302.28)	(\$17,738,385.72)	69.34%
	Transfers		(\$5,000,000.00)			
	Reimbursements/Refunds		(\$13,427.02)			
	Interest other accounts		\$5,707.43			
	<b>Total Revenue</b>		<b>(\$9,793,968.68)</b>			

Check Number	Payee	Amount
22393	BAKERS GAS & WELDING SUPPLIES, INC.	\$3,000.00
22394	BEE ME SENSORY GYM	\$150.00
22395	BLAZERWORKS, LLC	\$10,518.50
22396	DAS STATE ACCTG-CENTRAL FINANCE OCIO	\$330.00
22397	ESU #7	\$2,723.49
22398	FATHER FLANAGAN'S BOYS' HOME	\$43,680.00
22399	GOPHER SPORTS	\$3,203.25
22400	HAMPTON INN-KEARNEY	\$742.00
22401	JACKSON SERVICES INC.	\$224.11
22402	KAYE-SKINNER, BENJAMIN	\$400.00
22403	LANGUAGE LINE SERVICES INC	\$32.09
22404	MATHESON TRI-GAS INC	\$374.38
22405	NASB (NE. ASSOCIATION OF SCHOOL BOARDS)	\$185.00
22406	NCSA	\$75.00
22407	PITNEY BOWES - RESERVE ACCOUNT	\$1,000.00
22408	UNIVERSITY OF NEBRASKA LINCOLN	\$100.00
22409	VALENTINOS OF COLUMBUS	\$648.34
22410	AMAZON CAPITAL SERVICES	\$4,523.96
22411	SCHOOL DISTRICT #1-PAYROLL	\$3,863,189.24
22412	AMAZON CAPITAL SERVICES	\$272.95
22413	ASSOCIATED STAFFING, INC	\$11,512.04
22414	ESU #7	\$9,003.74
22415	GODFATHERS -COLUMBUS	\$59.98
22416	J.W. PEPPER & SON, INC	\$4.50
22417	JEFFRYES, MIKE	\$196.15
22418	KWAPNIOSKI, LEONARD R	\$117.45
22419	LIGHTHOUSE CHILD & FAMILY THERAPY, LLC	\$300.00
22420	ORTIZ BUSTAMANTE, ANA	\$103.67
22421	PLATTE VALLEY EQUIPMENT LLC	\$465.13
22422	SHEVLIN SUPPLY	\$1,262.52
22423	T-BONE TRUCK STOP	\$5,986.40
22424	COLUMBUS AREA CHILDRENS MUSEUM, INC	\$441.00
22425	AMABA, LLC	\$630.00
22426	ASSOCIATED STAFFING, INC	\$5,491.37
22427	AVIVE SOLUTIONS	\$11,230.90
22428	BIG APPLE BAGELS	\$149.97
22429	CENTRAL COMM COLLEGE - GI	\$71.00
22430	CHESTERMAN COMPANY	\$102.46
22431	COGNIA INC	\$11,200.00
22432	DAYLIGHT DONUTS	\$42.75
22433	EDGEWATER INSURANCE + REAL ESTATE	\$975.00
22434	ENABLE MY CHILD LTD	\$20,400.00
22435	ESU #7 SPECIAL EDUCATION	\$53,756.17
22436	ESU #1	\$50.00
22437	FASTENAL	\$150.05
22438	HAMPTON INN-KEARNEY	\$774.75

Columbus Public Schools  
 General Fund Expenditures  
 April 11 thr 30, 2026

22439	INTER-STATE STUDIO & PUBLISHING CO	\$345.01
22440	JOHNSON, AMORITA	\$69.12
22441	LARSON, ELIJAH	\$194.56
22442	LINCOLN CHILDREN'S ZOO	\$660.00
22443	STAHL, TANIA	\$139.08
22444	TROPICAL SMOOTHIE CAFE	\$50.00
22445	U AND I SANITATION LLC	\$2,235.00
22446	WOODRIVER ENERGY LLC	\$16,552.16
22447	COLUMBUS SCHOOL LUNCH FUND-CHS	\$546,789.00
22448	AMAZON CAPITAL SERVICES	\$2,851.85
22449	HY-VEE FOOD STORES	\$107.69
22450	SUPER SAVER	\$1,360.93
22451	TREVIPAY-WALMART	\$100.96
22452	ASSOCIATED STAFFING, INC	\$6,235.86
22453	ACE HARDWARE-COLUMBUS	\$21.73
22454	ARNOLD MOTOR SUPPLY-COLUMBUS	\$312.71
22455	AWARDS & ENGRAVING	\$11.00
22456	BOMGAARS	\$545.97
22457	CAPITAL SANITARY SUPPLY	\$1,720.40
22458	CLAY HILLS AG, LLC	\$9,430.00
22459	COLUMBUS MUSIC	\$118.00
22460	DAVIS, AMANDA	\$139.20
22461	ENGEL, SHELBY	\$528.96
22462	GARCIA, YURI	\$313.20
22463	GEHRING CONST. & READY MIX CO.	\$474.50
22464	GRAFE, TARA	\$264.48
22465	GREAT PLAINS BUILDING SUPPLY CO.	\$40.00
22466	HAYS, ALISHA	\$51.04
22467	HERLIN, REBECCA	\$15.08
22468	IMAGE TECH & PRINTING	\$94.39
22469	J.W. PEPPER & SON, INC	\$559.97
22470	JARESKE, KELSEY	\$231.42
22471	KELLY SUPPLY CO.	\$162.41
22472	KOCH EXCAVATING CO.	\$56.76
22473	MAXIM HEALTHCARE SERVICES, INC.	\$2,860.00
22474	MCPHILLIPS, BRIDGET	\$18.49
22475	MENARDS-COL	\$1,214.97
22476	MURPHY, DAWN	\$1,015.00
22477	O'REILLY AUTO PARTS-COL	\$31.75
22478	Olcott, Caitlin L	\$132.24
22479	PACZOSA, MEGAN	\$264.48
22480	PRESENCELEARNING INC	\$115,365.89
22481	SCHIEFFER SIGNS	\$55.00
22482	SCHOOL HEALTH CORPORATION	\$207.78
22483	STAROSCIK, KRISTINE	\$165.30
22484	TK ELEVATOR CORPORATION	\$2,262.00
22485	TRUCK CENTER COMPANIES	\$48.55

Columbus Public Schools  
General Fund Expenditures  
April 11 thr 30, 2026

22486	ULINE INC	\$2,138.09
22487	WARD'S SCIENCE	\$2,763.28
22488	WOODWORKER'S HARDWARE	\$320.55
22489	ZIEMBA, COURTNEY	\$123.97
22490	LEGACY 23 APARTMENTS	\$1,701.00
22491	LEGACY 23 APARTMENTS	\$1,495.00
22492	FIRST NATIONAL BANK OMAHA	\$129.40
22493	FIRST NATIONAL BANK OMAHA	\$2,236.68
22494	FIRST NATIONAL BANK OMAHA	\$321.00
22495	FIRST NATIONAL BANK OMAHA	\$339.00
22496	FIRST NATIONAL BANK OMAHA	\$331.87
22497	FIRST NATIONAL BANK OMAHA	\$3,002.19
22498	FIRST NATIONAL BANK OMAHA	\$628.09
22499	FIRST NATIONAL BANK OMAHA	\$9,201.89
22500	FIRST NATIONAL BANK OMAHA	\$129.99
22501	FIRST NATIONAL BANK OMAHA	\$3,843.52
22502	FIRST NATIONAL BANK OMAHA	\$8,129.29
<b>Total Expenditures</b>		<b>\$4,823,108.01</b>

<b>Check Number</b>	<b>Vendor</b>		<b>Amount</b>
3450	AMAZON CAPITAL SERVICES	\$	7.59
3451	HY-VEE FOOD STORES	\$	4,625.00
3452	JACKSON SERVICES INC.	\$	67.80
3453	VERIZON WIRELESS	\$	32.91
3454	SCHOOL DISTRICT #1-PAYROLL	\$	130,341.20
3455	ASSOCIATED STAFFING, INC	\$	857.75
3456	ESU #7	\$	90.46
3457	JACKSON SERVICES INC.	\$	68.20
3458	AMAZON CAPITAL SERVICES	\$	91.22
3459	ASSOCIATED STAFFING, INC	\$	870.03
3460	HY-VEE FOOD STORES	\$	6,819.00
3461	LUNCHTIME SOLUTIONS, INC	\$	162,664.27
3462	MENARDS-COL	\$	23.96
3463	SCHOOL DISTRICT #1 GEN FUND	\$	50,000.00
	Total Fund Expenditures	\$	<u><u>356,559.39</u></u>

Columbus Public Schools  
 Summary of Cash Balances -QCPUF  
 April 30, 2026

M9	DESCRIPTION	BEGINNING BALANCE	MONTH TO DATE RECEIPTS	MONTH TO DATE EXPENDITURES	END OF MONTH BALANCE	YTD BALANCE PRIOR YEAR
	Amazon			\$255.46		
	Apple Inc			\$745.00		
	Avive Solutions			\$1,955.06		
	B-D Construction Inc			\$34,942.51		
	CDW Government, Inc			\$1,395.37		
	Commonwealth Electric Midwest			\$62,955.90		
	Eakes Office Solutions			\$4,380.00		
	EpcO LTD, Inc			\$340.00		
	First National Bank Omaha			\$389.29		
	Receipts					
	Transfers					
	Interest		\$ 2,890.66			
	<b>QCPUF OPERATING -- COLUMBUS BANK</b>	<b>\$ 1,038,657.25</b>	<b>\$ 2,890.66</b>	<b>\$ 107,358.59</b>	<b>\$ 934,189.32</b>	
	Transfers					
	Receipts		\$ 55,232.22			
	Interest		\$ 471.15			
	<b>QCPUF BOND-- COLUMBUS BANK</b>	<b>\$ 265,799.23</b>	<b>\$ 55,703.37</b>	<b>\$0.00</b>	<b>\$321,502.60</b>	

\*Totals are the Operating and ICS Savings combined for each account



# Professional Travel Report

April 2026 • Prepared for the Board of Education

Summary of professional leave travel for Columbus Public Schools staff. **49** engagements are listed below in chronological order.

Employee	Date(s)	Conference	Location
Chip Kay	Apr 01, 2026	NCSA / Nebraska National Guard Leadership Training	—
David Hiebner	Apr 01, 2026	South Dakota State Teacher Fair	Brookings, SD
Jason Schapmann	Apr 01, 2026	SDSU Career Fair	Brookings, SD
Angela Kruse	Apr 08, 2026	NPERS Retirement Seminar	Norfolk, NE
Pamela Homolka	Apr 08–09, 2026	(Pending — coverage being arranged)	—
Amy Haynes	Apr 09, 2026	NPERS Retirement Seminar	—
Caitlyn Byrnes	Apr 09–10, 2026	ASD Conference	Kearney, NE
Chelsea Werner	Apr 09–10, 2026	ASD Conference (online)	Kearney, NE
Chip Kay	Apr 09–13, 2026	NASB / NSBA Annual Conference	San Antonio, TX
Elissa Heibel	Apr 09–10, 2026	ASD Conference	Kearney, NE
Jason Harris	Apr 09–13, 2026	National School Boards Conference	San Antonio, TX
Jennifer Bos	Apr 09–10, 2026	Nebraska ASD Conference	Kearney, NE
Jennifer Lange	Apr 09, 2026	Learning Forward Nebraska Conference	ESU 3, LaVista, NE
Julie Kreikemeier	Apr 09, 2026	Literacy Leadership: Coaching for Impact	ESU 3
Kari Ortiz	Apr 09–10, 2026	ASD State Conference (online)	Kearney, NE
Katherine Juranek	Apr 09–10, 2026	ASD Convention	Kearney, NE
Katherine Juranek	Apr 09–10, 2026	ASD Conference	Kearney, NE
Kristine Hackett	Apr 09, 2026	Jim Knight PD	ESU 3
Ryan Goetsch	Apr 09, 2026	Nebraska ASD Conference	Kearney, NE
Teresa Hausmann	Apr 09, 2026	NPERS Appointment	—



<b>Employee</b>	<b>Date(s)</b>	<b>Conference</b>	<b>Location</b>
Jason Schapmann	Apr 10, 2026	Wayne State College Student Teacher Accreditation Meeting	Wayne, NE
Leonard Kwapnioski	Apr 10, 2026	NATA Meeting	Lincoln, NE
Nicole Anderson	Apr 10, 2026	NebSPRA Monthly Meeting (Kordica)	Omaha, NE
Ryan Goetsch	Apr 10, 2026	Nebraska ASD Conference	Kearney, NE
Chip Kay	Apr 14, 2026	NCSA Executive Board Meeting	Lincoln, NE
Chip Kay	Apr 15, 2026	GNSA Executive Council & Meeting	Lincoln, NE
Leonard Kwapnioski	Apr 15, 2026	NITC Meeting	Lincoln, NE
Jason Harris	Apr 16–17, 2026	NASES Spring Conference	Omaha, NE
Jason Schapmann	Apr 16, 2026	NASBO Conference	—
Jason Schapmann	Apr 17, 2026	NASBO Conference	—
Chip Kay	Apr 20–21, 2026	2026 National Superintendent Forum (Speaker)	St. Louis, MO
Chip Kay	Apr 23–24, 2026	NASBO Conference	Lincoln, NE
Jason Schapmann	Apr 23–24, 2026	NASBO Conference	Lincoln, NE
Kim Loeffelholz	Apr 24, 2026	Counselor Day	Southeast Community College
Rebecca Lenser	Apr 24, 2026	NSEA Delegate Assembly	—
Valerie Brown	Apr 24, 2026	School Counselor Visit Day	Southeast Community College, Lincoln, NE
Ashley Korth	Apr 27, 2026	Kindergarten Field Trip	—
Adam Whitmore	Apr 29, 2026	Perkins Career & Technical Education Activity	—
Brandi Fleming	Apr 29, 2026	Nebraska Google for Education Summit	Kearney, NE
Cletus Arasmith	Apr 29, 2026	Nucor Tour (Perkins CTE)	—
Jason Harris	Apr 29, 2026	OSEP State Reporting Training (Part C)	Fremont, NE
Joseph Krysl	Apr 29, 2026	Nucor Steel Industries Tour (Perkins CTE)	Norfolk, NE



<b>Employee</b>	<b>Date(s)</b>	<b>Conference</b>	<b>Location</b>
<b>Matthew Hoenk</b>	Apr 29, 2026	Master's Program Internship Hours	Lincoln NE (LNE)
<b>Michelle Oppliger</b>	Apr 29, 2026	Nebraska Google for Education Summit	Kearney, NE
<b>Aaron Rose</b>	Apr 30 – May 01, 2026	NETA Conference (Perkins CTE)	—
<b>Adrienne Didier</b>	Apr 30, 2026	NETA Conference (Day 1)	—
<b>Alexander Dostal</b>	Apr 30, 2026	CLS Trip to the Zoo	—
<b>Kimberly Schoenberner</b>	Apr 30 – May 01, 2026	Nebraska Educational Technology Conference (NETA)	—
<b>Tory Gilson</b>	Apr 30 – May 01, 2026	NETA Conference (Perkins CTE)	—



**COLUMBUS  
PUBLIC SCHOOLS  
FOUNDATION**

2410 16th Street, Suite A, P.O. Box 947, Columbus, NE 68602-0947 Phone: 402-563-7000, Ext. 13033 Fax: 402-563-7005

---

May 7, 2026

Mike Jeffryes  
Board of Education  
Columbus Public Schools

Dear President Jeffryes and Members of the Board:

The Foundation contributed the following items to Columbus Public Schools during the month of April. On behalf of the Board of Directors for the CPS Foundation and the officers of the thirteen umbrella organizations, we respectfully submit these items to the Board of Education for acceptance.

**Foundation**

\$5,366.15 - Columbus After School Program

**Centennial PAC**

\$417.24 - March Madness Activity  
\$60.73 - Egg Hunt Supplies  
\$350.00 - Family Picnic  
\$240.00 - Bingo Books  
\$130.45 - Meeting Supplies  
\$1,576.22 - One School One Book  
\$245.00 - 3rd Grade NSCAS Reward  
\$460.00 - Gold Coin & May Day Basket Popcorn  
\$557.32 - Field Trip  
\$1,436.15 - Teacher Appreciation Supplies

**Sports Boosters**

\$3,899.00 - Baseball Pitching Machine

**Post Prom**

\$151.15 - Printing

**Emerson PTO**

\$207.00 - 4th Grade Field Trip  
\$25.00 - Bingo Rental

**Lost Creek PTO**

\$225.54 - Teacher Appreciation Supplies

**North Park PTO**

\$133.19 - March Staff Snack Cart  
\$70.83 - Classroom Support  
\$83.93 - Teacher Appreciation Supplies  
\$250.00 - End of Year DJ

The total contributions for the month of April was \$15,884.90

The total contributions for the FY 2026 total is **\$79,068.59**

*\*CPS Foundation's fiscal year is January 1 through December 31.*

Thank you for your consideration.

Sincerely,



Nicole Anderson  
Communication & Foundation Director

# Department of Teaching & Learning Updates



May 2026



- Gr K-2 MAP Growth
- Gr 3-8 NSCAS Growth
- 9 & 10 PreACT
- 11 ACT

Data Meetings with Principals to analyze results



## Columbus Family Literacy Family Program Community Conversation Summary



1. Grades 1, 2 & 4 - Pacing and updating data points
2. Gr 6-8 Advanced Math Placement - Scoring Tests & Determining Cut Scores

# Teaching & Learning Teacher/Principal Support

"Engaging All Learners to Achieve Success"



April 2026  
292 Teacher/Principal Touch Points

We track engagement through dialogue, collaboration, and classroom visits.

# Nebraska Statewide Family Engagement Center

## Columbus Family Literacy Family Program Community Conversation Summary

*Prepared by:*

**Nebraska Children and Families Foundation**

**Research and Evaluation Team**

*Fallon Watts*

*April 2026*

---

# Columbus Family Literacy Program (FLM) Community Conversation Summary

---

Date of Conversation: April 16, 2026

Location: Columbus, Nebraska

Facilitator: Fallon Watts

Interpreter Language Support: Spanish, French, Arabic

Number of Parent Participants: 7 parents

## Introduction

This document summarizes parent feedback shared through a community conversation with parents participating in Columbus Family Literacy Program (FLM). Feedback was gathered across two small group discussions with interpreter support. Parents shared their motivations for joining the program, factors supporting ongoing participation, perceived impacts on themselves and their families, and ideas for strengthen the program. Overall, parents expressed high satisfaction with the program and deep appreciation for the instructor and learning environment. Parents emphasized that participation has significantly improved their confidence, English language skills, and ability to support their children, grandchildren, and families in daily life.

## Parent Motivations for Joining the Program

*Parents join the FLM program to learn English, support their children and families, and build confidence in daily life.*

Parents consistently shared that learning English was their primary motivation for joining the Family Literacy Program. Several parents noted they had tried other paid or community-based English classes in the past but experienced less progress than they have through this program.

Parents described wanting to:

- Help children and grandchildren with schoolwork and understand homework
- Communicate more effectively at work and complete paperwork independently

- Understand conversations with teachers and school staff
- Support extended family members
- Build community connections and confidence

Some parents learned about the program through personal connections, such as neighbors or school staff, and shared a desire for broader outreach. One parent suggested sending information through school parent apps or flyers so more families are aware of the opportunity. Access to childcare was also identified as a critical factor that enabled participation by removing a major barrier to attendance.

## Factors Supporting Continued Engagement

*Supportive teaching, flexibility, and visible progress keep parents engaged.*

Parents emphasized that the instructor’s care, patience, and encouragement were among the most important factors supporting continued participation. Parents described the teacher as fun, motivating, and responsive to individual strengths and needs, creating a welcoming and inclusive classroom environment. Seeing tangible progress, such as being able to speak, write, and understand English more confidently, motivated parents to continue attending. Feeling integrated into the class and comfortable asking questions contributed to a strong sense of belonging.

Additional supports reinforcing engagement included:

- Encouragement and flexibility from the instructor
- Feeling valued and respected as learners
- Food and shared meals that foster connection
- Access to learning tools, such as a language-learning app to practice at home

Parents emphasized that while small supports are helpful, the greatest incentive is learning itself and the progress they are making.

## Barriers to Attendance

*Parents reported few barriers, though work and family responsibilities occasionally limit attendance.*

- Overall, parents felt that there were minimal barriers to participation. When challenges did occur, they most often involved:

- Work schedules
- Medical or other appointments
- Illness (their own or within their family)

Despite these barriers, parents stated they prioritize attending sessions whenever possible.

## **Impact on School Communication and Engagement**

*Improve English skills have strengthened parents' communication with schools.*

Parents reported positive changes in their interactions with their children's schools. Many shared that after participating in the program, they feel more comfortable communicating directly with teachers and better understand classroom expectations and school information.

Parents noted they can now:

- Understand teacher communication more clearly
- Speak directly with teachers during pick-up or conferences
- Guide children in what to say in English
- Better understand what children are learning in school

These changes have increased parents' confidence and engagement in their children's education.

## **Family and Child Outcomes**

*Families experience stronger communication and increase shared learning.*

Parents shared that participation in the program has positively impacted family relationships. Parents described improved communication at home, including talking more regularly in English about school and daily experiences.

Examples of family level impacts included:

- Helping children navigate friendships, communication, and conflict
- Supporting family members' English learning
- Increased shared learning and mutual support among family members

One parent shared that understanding more English allowed them to better monitor conversations between their children and intervene when needed. Several parents noted their children appear happier, and families feel more connected through shared learning.

## **Progress Toward Personal and Educational Goals**

*Parents reported meaningful progress towards independence, communication, and confidence.*

Parents described clear progress towards personal goals including:

- Speaking and understanding English more effectively at work
- Feeling confident communicating with others in English
- Completing paperwork independently
- Attending appointments without assistance
- Helping children with reading and homework

Several parents highlighted additional learning opportunities offered through the program, such as visits from community partners (e.g., EMT first aid instruction), which helped them build practical skills and social connections. Some parents also shared longer term educational or workforce aspirations, including pursuing a GED, CNA license, and operating their own business, noting that improved English skills are a key foundation for these plans.

## **Strengths of the Program**

Many parents stated this program has been more effective than other English learning opportunities they have tried, particularly given the progress achieved in a relatively short time.

Parents consistently identified the program's strongest aspects as:

- The patience, flexibility, and encouragement of the instructor
- A supportive and inclusive learning environment
- Opportunities to actively practice speaking English
- Social connection and relationship-building

- A schedule that works well for many families

## Suggestions for Improvement

*Parents ideas reflect aspirations for growth rather than dissatisfaction.*

Parents expressed interest in expanding the program, including:

- Offering more days or hours each week
- Providing multiple levels (e.g., beginner, intermediate, advanced)
- Smaller or more targeted groupings to support varying language levels
- Earlier start times for beginner level instruction

Parents acknowledged the complexity of expansion and emphasized that these ideas reflect the value they see in the program rather than critiques.

## Conclusion

Parents expressed deep gratitude for the Columbus Family Literacy Program and described it as one of the best experiences they have had for learning English and building confidence. Parents consistently highlighted the instructor's role in creating a respectful, supportive, and motivating learning environment.

The program is making a meaningful difference for parents, children, and families by strengthening communication, confidence, independence, and connections to schools and community. Parents expressed a strong desire to continue participating and shared hope that additional families will have access to this opportunity in the future.

## Year-to-Date Expenditures by Function

Function Code	Description	YTD Expended	% of Overall Budget
<b>1000 Series — Instruction</b>			
01100	Regular Instruction	\$5,175,413.01	8.94%
01115	Career Academy Programs (Rule 47)	\$63,500.40	0.11%
01125	Regular Instructional Programs – Non-General Ed	\$270,489.54	0.47%
01150	Limited English Proficiency Programs	\$3,582,841.24	6.19%
01160	Poverty Programs	\$7,321,186.64	12.65%
01190	Early Childhood Educational Programs	\$561,369.25	0.97%
01200	Special Education Instruction - School Age	\$5,985,437.96	10.34%
01295	Special Education - Unified Sports	\$2,649.63	0.00%
01300	Summer School	\$281.77	0.00%
<b>Subtotal — 1000 Series — Instruction</b>		<b>\$22,963,169.44</b>	<b>39.69%</b>
<b>2100 Series — Student Support Services</b>			
02110	Attendance & Social Work Services	\$251,368.87	0.43%
02120	Guidance Services	\$406,470.34	0.70%
02130	Health Services	\$447,346.63	0.77%
02131	Health Services - SPED School Age	\$22,685.00	0.04%
02141	Psychological Services - SPED School Age	\$519,114.79	0.90%
02151	Speech Pathology & Audiology - SPED School Age	\$1,404,994.18	2.43%
02161	Occupational Therapy - SPED School Age	\$168,809.33	0.29%
02171	Physical Therapy - SPED School Age	\$77,786.87	0.13%
02181	Visually Impaired Services - SPED School Age	\$31,849.48	0.06%
02190	Support Services - Other (Activities)	\$935,868.78	1.62%
<b>Subtotal — 2100 Series — Student Support Services</b>		<b>\$4,266,294.27</b>	<b>7.37%</b>
<b>2200 Series — Instructional Support Services</b>			
02211	School Improvement	\$11,200.00	0.02%
02212	Instruction & Curriculum Development	\$353,097.81	0.61%
02213	Instructional Staff Training	\$39,854.19	0.07%
02220	Library/Media Services	\$400,924.33	0.69%
02223	Audio/Visual Services	\$2,222.00	0.00%
02230	Instruction-Related Technology	\$634,893.98	1.10%

Function Code	Description	YTD Expended	% of Overall Budget
02240	Academic Student Assessment	\$9,676.99	0.02%
02290	Support Services - Other (Instruction)	\$5,538.63	0.01%
<b>Subtotal — 2200 Series — Instructional Support Services</b>		<b>\$1,457,407.93</b>	<b>2.52%</b>
<b>2300 Series — General Administration</b>			
02310	Board of Education	\$95,273.77	0.16%
02320	Executive Administration	\$299,256.72	0.52%
02330	District Legal Services	\$45,671.50	0.08%
<b>Subtotal — 2300 Series — General Administration</b>		<b>\$440,201.99</b>	<b>0.76%</b>
<b>2400 Series — School Administration</b>			
02410	Office of the Principal	\$2,028,372.65	3.51%
<b>Subtotal — 2400 Series — School Administration</b>		<b>\$2,028,372.65</b>	<b>3.51%</b>
<b>2500 Series — Central Services</b>			
02510	Fiscal Services	\$547,880.50	0.95%
02560	Public Information Services	\$147,121.33	0.25%
02570	Personnel Services	\$270,314.71	0.47%
02580	Administrative Technology Services	\$141,692.38	0.24%
02590	Central Services - Other	\$38,344.55	0.07%
<b>Subtotal — 2500 Series — Central Services</b>		<b>\$1,145,353.47</b>	<b>1.98%</b>
<b>2600 Series — Operations &amp; Maintenance of Plant</b>			
02610	Operation of Buildings	\$2,626,906.18	4.54%
02620	Maintenance of Buildings	\$477,597.63	0.83%
02630	Care & Upkeep of Grounds	\$201,966.72	0.35%
02650	Vehicle Operation, Maint. & Purchasing (non-student)	\$12,031.17	0.02%
02660	Security	\$87,712.38	0.15%
02670	Safety	\$65,121.44	0.11%
<b>Subtotal — 2600 Series — Operations &amp; Maintenance of Plant</b>		<b>\$3,471,335.52</b>	<b>6.00%</b>
<b>2700 Series — Student Transportation</b>			
02710	Vehicle Operation & Purchasing - Regular Ed Transp.	\$432,647.13	0.75%
02712	Vehicle Operation & Purchasing - SPED School Age	\$304,060.66	0.53%
02713	Vehicle Operation & Purchasing - SPED Ages 3-5	\$34.68	0.00%

Function Code	Description	YTD Expended	% of Overall Budget
02730	Vehicle Servicing & Maintenance - Regular Ed	\$17,034.57	0.03%
02732	Vehicle Servicing & Maintenance - SPED School Age	\$29,914.66	0.05%
<b>Subtotal — 2700 Series — Student Transportation</b>		<b>\$783,691.70</b>	<b>1.35%</b>
<b>2900 Series — Other Support Services</b>			
02900	Other Support Services	\$5,000.00	0.01%
<b>Subtotal — 2900 Series — Other Support Services</b>		<b>\$5,000.00</b>	<b>0.01%</b>
<b>3000 Series — Operation of Non-Instructional Services</b>			
03300	Community Services	\$3,893.78	0.01%
03301	Community Services - ASP	\$229,171.04	0.40%
03305	Custody & Child Care Services	\$26,732.00	0.05%
03535	High Ability Learners	\$3,757.10	0.01%
03540	State Early Childhood	\$97,671.75	0.17%
03541	Early Childhood Endowment (Sixpence)	\$125,291.63	0.22%
03551	Career Education	\$12,391.36	0.02%
03590	Extended Learning Opportunity Grants	\$518.76	0.00%
<b>Subtotal — 3000 Series — Operation of Non-Instructional Services</b>		<b>\$499,427.42</b>	<b>0.86%</b>
<b>4000 Series — Facilities Acquisition &amp; Construction</b>			
04600	Facilities Acquisition & Construction	\$9,104.59	0.02%
<b>Subtotal — 4000 Series — Facilities Acquisition &amp; Construction</b>		<b>\$9,104.59</b>	<b>0.02%</b>
<b>6000 Series — Federal Programs</b>			
06200	Federal IDEA Special Education (general)	\$525,907.68	0.91%
06210	Federal Special Education Programs	\$14,669.63	0.03%
06310	Comprehensive Literacy State Development (CLSD)	\$138,619.63	0.24%
06406	IDEA Part B (611) Base Allocation Ages 3-5	\$27,188.16	0.05%
06408	IDEA Part B (611) Base Allocation/EP	\$1,039,290.28	1.80%
06412	IDEA Part B Proportionate Share (Non-Public)	\$137,133.68	0.24%
06700	Federal Vocational & Applied Tech Ed (Carl Perkins)	\$36,415.91	0.06%
06925	Title III ESSA - English Language Acquisition	\$83,105.84	0.14%
06926	Title III ESSA - Immigrant Education	\$17,846.74	0.03%
06968	Title IV-B ESSA - 21st Century Community Learning Ctrs	\$104,104.17	0.18%
06969	Title IV-A ESSA - Student Support & Academic Enrichment	\$25,055.09	0.04%

Function Code	Description	YTD Expended	% of Overall Budget
06991	McKinney-Vento Homeless	\$4,081.07	0.01%
<i>Subtotal — 6000 Series — Federal Programs</i>		<b>\$2,153,417.88</b>	<b>3.72%</b>
<b>8000 Series — Transfers (Outgoing)</b>			
08000	Transfers Out (to other funds)	\$621,789.00	1.07%
<i>Subtotal — 8000 Series — Transfers (Outgoing)</i>		<b>\$621,789.00</b>	<b>1.07%</b>
<b>TOTAL YTD EXPENDED</b>		<b>\$39,844,565.86</b>	<b>68.86%</b>
<b>TOTAL GENERAL FUND BUDGET</b>		<b>\$57,862,688.00</b>	<b>100.00%</b>
<b>BUDGET REMAINING</b>		<b>\$18,018,122.14</b>	<b>31.14%</b>



## COLUMBUS PUBLIC SCHOOLS

**Date:** May 11, 2026  
**To:** Board of Education  
**From:** Dr. Chip Kay, Superintendent  
**Subject:** Administrator Wage & Benefit Recommendation for 2026–2027

I am submitting for your consideration a recommendation regarding wages and benefits for the 2026–2027 school year for administrative staff of Columbus Public Schools.

This recommendation applies to a group of 21 employees who are compensated on the Administrator Salary Schedule, hold an administrative certificate, and serve in the capacity of Director, Principal, or Assistant Principal. These individuals play a critical role in advancing district goals, supporting student achievement, and ensuring effective building and program leadership.

For the 2026–2027 school year, I recommend a total compensation increase of **2.95%**, representing a comprehensive total increase of **\$104,661** over the 2025–2026 school year. This increase reflects both wage and benefit considerations.

It is important to note that the 2.95% increase is **not applied uniformly** across all administrators. Adjustments have been made based on factors including market competitiveness, internal equity, experience, and role-specific responsibilities. This approach ensures a more strategic and equitable distribution of resources while maintaining our ability to recruit and retain high-quality leadership.

This recommendation aligns with the district’s commitment to fiscal responsibility while recognizing the essential contributions of our administrative team.

I respectfully request the Board of Education’s approval of this wage and benefit recommendation for the 2026–2027 school year.

Please let me know if additional information or analysis would be helpful as you consider this recommendation.

**Dr. Chip Kay**  
Superintendent

***“Engaging All Learners to Achieve Success”***

2508 27th Street | Columbus, Nebraska, 68601 | Ph: 402.563.7000 | Fx: 402.563.7005

[ColumbusPublicSchools.org](http://ColumbusPublicSchools.org)



**Empowering all who  
serve students with  
diverse needs**

Presence.com

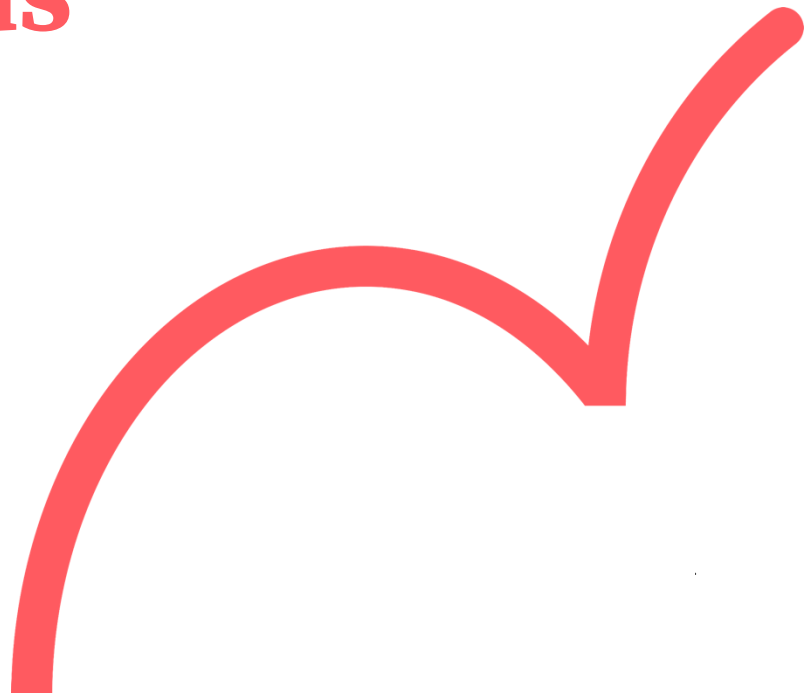

# Comprehensive telepractice for PreK-12 schools

Presence is excited to partner with Columbus Public Schools - NE to implement comprehensive teletherapy programs that support students across the district. As the leading provider of online special education-related services since 2009, Presence has pioneered teletherapy solutions with schools across the country.

**7M+**

sessions delivered

**10K+**

schools supported

**2,000+**

clinicians in network

## From special education services to mental health counseling, we bring customized solutions to your district

We offer a full range of remote services (from observations and assessments to counseling and therapy) that help meet your district's speech-language, occupational, psychoeducational and mental health service needs.

### **Our clinical network brings a complete scope of practice to support schools with services that include:**

- Student screening, observation, identification, and evaluation
- Development and management of Response to Intervention (RTI) programs
- Case management and contribution to writing and updating of IEPs and 504 plans
- Full evaluations or re-evaluations utilizing standardized assessment tools
- Leading, attending, and/or contributing to meetings
- Individual or group therapy services
- Virtual classroom push-in services
- Completing paperwork for IEPs, review of records and Medicaid billing

# Solutions customized to meet student needs— backed by school-based experience and innovative technology



## Services that help fill assessment and therapy gaps

- Evaluations are delivered remotely using the largest library of digital assessments from trusted publishers like Pearson®, Riverside Insights®, and Pro-Ed®\*
- Customized teletherapy plans are based on your district's diverse student and staffing needs



## Clinically-led teams, trusted by 10,000+ schools

- Our national network of 2,000+ licensed speech-language pathologists, occupational therapists, school psychologists, and mental health clinicians brings services that support unique needs—including bilingual, deaf, and hard-of-hearing specializations
- Every district and clinician is backed by a dedicated clinical support team with years of experience implementing teletherapy solutions and navigating PreK-12 school systems



## Innovative technology, built specifically for students

- An award-winning, interactive teletherapy platform with access to engaging content from Hasbro®, Highlights®, and more\*
- Track student attendance to therapy sessions, documentation and progress to ensure compliance with IDEA
- HIPAA and FERPA compliant teletherapy platform technology

*\*All product names and registered trademarks are the property of their respective owners.*



Give your district team tools to conduct their own therapy sessions with Kanga. Built-in tools reduce the time and stress of scheduling, caseload management, data organization, and session planning. Students and clinicians can engage in a collaborative, virtual space with access to thousands of curated articles, games, and digital assessments.



# Service Order

PRESENTED TO

**Jason Harris**

Director of Special Needs

Columbus Public Schools - NE

ISSUE DATE

**5/6/2026**

BY

**Kelly Wright**

School Partnership Director

kelly.wright@presence.com



## Service Order Summary

This Service Order (the “Service Order”) is incorporated and made part of the Master Services Agreement (the “MSA”) between PresenceLearning, Inc. (“Presence”) and Columbus Public Schools - NE. Capitalized terms not defined in this Service Order shall have the meanings set forth in the MSA. In the event of a conflict between this Service Order and the MSA, unless specifically referenced herein, the MSA shall govern.

SERVICE ORDER TERM

8/3/2026 - 6/30/2027

	ANNUAL EST
<b>Weekly Dedicated Services</b>	<b>\$1,137,600.00</b>
Weekly Hours: 400	
Weekly Subtotal: \$31,600	
Weeks of Service: 36	
Dedicated Services Period: 8/17/2026-5/19/2027	
<hr/>	
<b>Program Readiness*</b>	<b>\$56,900.00</b>
<b>Program Management**</b>	<b>\$45,600.00</b>
<b>Total Estimated Cost</b>	<b>ANNUAL \$1,240,100.00</b>

\* Program Readiness (formerly Program Implementation ) is billed once upon the Service Order Execution Date.

\*\* Program Management (formerly Service Coordination) is billed monthly beginning in the first month in which Services are rendered.



## Service Order Details

SERVICE ORDER TERM

8/3/2026 - 6/30/2027

### Dedicated Services Summary

Clinical Services	Rate	Hours	Total
Speech-language therapy	\$79.00	400.00	\$31,600.00
Weekly total of Clinical Services		400.00	\$31,600.00
Weeks			36.00

**Estimated Dedicated Services Costs (annual)**

**\$1,137,600.00**

- - - Continued on next page - - -



## Service Order Details

SERVICE ORDER TERM

8/3/2026 - 6/30/2027

### **Flexible hourly rates with Dedicated Services**

Services provided in addition to, or in excess of, any Weekly Dedicated Hours shall be invoiced at the applicable hourly rate(s) set forth in this Service Order.

Clinical Services	Per hour
Speech-language therapy	\$87.00

- - - Continued on next page - - -

# Assessment Components

	<b>Per Service</b>
SLP Assessments Bundle	
Screening by SLP	\$82.00
Bilingual Screening by SLP	\$137.00
Evaluation Coordination and Results Summary by SLP	\$282.00
Evaluation Coordination and Results Summary by Bilingual SLP	\$319.00
Review of Records by SLP	\$137.00
Additional Assessment by SLP	\$79.00
Articulation Standard Assessment by SLP	\$120.00
Auditory Processing Assessment by SLP	\$132.00
Early Childhood Language Assessment by SLP	\$181.00
Fluency Standard Assessment by SLP	\$165.00
Language Standard Assessment by SLP	\$235.00
Pragmatic Language Standard Assessment by SLP	\$137.00
Phonological Process Analysis by SLP	\$70.00
Phonological Processing Assessment by SLP	\$120.00
Supplemental Language Screener by SLP	\$64.00
Spanish Language Standard Assessment by SLP	\$235.00
Spanish Language Select Subtests by SLP	\$99.00
Spanish Auditory Processing Select Subtests by SLP	\$134.00
Additional Bilingual Assessment by SLP	\$99.00
Spanish Articulation Measures (SAM) by SLP	\$94.00
Spanish Articulation Standard Assessment by SLP	\$110.00
Extended Coordination by SLP	\$70.00
Language Difference vs. Disorder Analysis by SLP	\$105.00
Unplanned Student Absence SLP	\$56.00
Parent Interview by SLP	\$70.00
Teacher Interview by SLP	\$70.00

	<b>Per Service</b>
OT Assessments Bundle	
Screening by OT	\$80.00
Review of Records by OT	\$136.00
Standard School-Related-ADL Assessment by OT	\$107.00
Standard Sensory Processing Assessment by OT	\$82.00
Standard Motor Skills Assessment by OT	\$135.00
Standard Visual Perception Assessment by OT	\$107.00
Standard Preschool Assessment by OT	\$168.00
Additional Assessment Component by OT	\$80.00
Extended Coordination by OT	\$70.00
Informal Fine Motor Assessment by OT	\$87.00
Unplanned Student Absence OT	\$56.00
Parent Interview by OT	\$70.00
Teacher Interview by OT	\$70.00
Student Interview by OT	\$70.00
Results Meeting by OT	\$136.00
Evaluation Coordination and Results Summary by OT	\$176.00
Observation by OT	\$102.00
Additional Requested Meeting by OT	\$59.00
Goal Writing by OT	\$59.00
Schoolwide Support by OT	\$74.00
Bilingual Evaluation Coordination and Results Summary by OT	\$266.00
Bilingual Results Meeting by OT	\$107.00
Additional Requested Paperwork by OT	\$59.00

Student Interview by SLP	\$70.00
Results Meeting by SLP	\$137.00
Bilingual Evaluation: Special Considerations	\$37.00
Rating Scale Assessment by SLP	\$137.00
AAC Evaluation: Special Considerations	\$37.00
AAC: Device analysis	\$70.00
AAC: Device trial	\$37.00
AAC: Feature matching trials	\$37.00
Speech-Language Sample by SLP	\$137.00
Observation by SLP	\$105.00
Additional Requested Meetings by SLP	\$59.00
Additional Bilingual Paperwork by SLP	\$59.00
Bilingual Student Interview by SLP	\$59.00
Bilingual Results Meeting by SLP	\$117.00
Additional Bilingual Meeting by SLP	\$59.00
Goal Writing by SLP	\$59.00
Additional Requested Paperwork by SLP	\$59.00
Bilingual Parent Interview by SLP	\$59.00
Schoolwide Support by SLP	\$75.00

	<b>Per Service</b>
BMH Assessments Bundle	
Additional Assessment by MHP/Ed Diag	\$266.00
Additional Requested Paperwork by MHP/Ed Diag	\$75.00
Screening by MHP/Ed Diag	\$156.00
Review of Records by MHP/Ed Diag	\$255.00
Rating Scale Assessment by MHP/Ed Diag	\$209.00
Evaluation Coordination and Results Summary by MHP/Ed Diag	\$323.00
Additional Requested Meetings by MHP/Ed Diag	\$75.00
Functional Behavior Assessment by MHP/Ed Diag	\$377.00
Intervention Data Analysis by MHP/Ed Diag	\$64.00
Parent Interview by MHP/Ed Diag	\$64.00
Student Interview by MHP/Ed Diag	\$75.00
Teacher Interview by MHP/Ed Diag	\$75.00
Unplanned Student Absence MHP/Ed Diag	\$82.00
Extended Coordination by MHP/Ed Diag	\$75.00
Observation by MHP/Ed Diag	\$146.00

	<b>Per Service</b>
Psychoeducational Assessment Bundle	
Review of Records by MHP/Ed Diag	\$250.00
Cognitive Select Subtests	\$170.00
Processing Select Subtests	\$176.00
Achievement Select Subtests	\$126.00
Rating Scale Assessment by MHP/Ed Diag	\$186.00
Achievement Standard Battery	\$248.00
Long Cognitive Battery	\$319.00
Additional Assessment by MHP/Ed Diag	\$266.00
Processing Standard Battery	\$319.00
Additional Requested Meetings by MHP/Ed Diag	\$64.00
Short Cognitive Battery	\$165.00
Spanish Select Subtests	\$186.00
Spanish Cognitive Battery	\$346.00
Screening by MHP/Ed Diag	\$142.00
Additional Requested Paperwork by MHP/Ed Diag	\$75.00
Functional Behavior Assessment by MHP/Ed Diag	\$389.00
Intervention Data Analysis by MHP/Ed Diag	\$64.00

Results Meeting by MHP/Ed Diag	\$117.00
Bilingual Results Meeting by MHP	\$112.00
Bilingual Evaluation Coordination and Results Summary by MHP	\$292.00
Goal Writing by MHP	\$59.00
Schoolwide Support by MHP	\$74.00

Parent Interview by MHP/ Ed Diag	\$75.00
Student Interview by MHP/Ed Diag	\$75.00
Teacher Interview by MHP/Ed Diag	\$64.00
Unplanned Student Absence MHP/Ed Diag	\$82.00
Results Meeting by MHP/Ed Diag	\$120.00
Extended Coordination by MHP/Ed Diag	\$64.00
Additional Requested Meetings by MHP/Ed Diag	\$64.00
Evaluation Coordination and Results Summary by MHP/Ed Diag	\$314.00
Observation by MHP/Ed Diag	\$173.00
Bilingual Evaluation Coordination and Results Summary by MHP/Ed Diag	\$319.00
Spanish Achievement Battery	\$346.00
Goal Writing by MHP/ED Diag	\$64.00
Schoolwide Support by MHP/Ed Diag	\$78.00
Bilingual Review of Records by MHP/Ed Diag	\$562.00
Bilingual Results Meeting by MHP/Ed Diag	\$117.00
Bilingual Parent Interview by MHP/Ed Diag	\$59.00

# Service Order Signature Page

Except as expressly set forth in this Service Order, the parties agree to be bound by the terms of the MSA.

The parties have executed this Service Order as of the date of the latter signature ("Service Order Effective Date").

<b>PRESENCELEARNING, INC:</b>	<b>CUSTOMER:</b>
By: Name: Title: Date:	By: Name: Title: Date:



## B.I.S.T SERVICES AGREEMENT 2026-2027 School Year



### CLIENT INFORMATION

<b>DISTRICT, School:</b>	COLUMBUS PUBLIC SCHOOLS #1
<b>Address:</b>	2508 27 <sup>th</sup> Street, Columbus, NE 68601
<b>Contact:</b>	Jason Harris, Director Student Services/Special Education
<b>Telephone:</b>	402-563-7000
<b>Email:</b>	<a href="mailto:harrisj@discoverers.org">harrisj@discoverers.org</a>

### CORNERSTONES OF CARE INFORMATION

<b>Name:</b>	Cornerstones of Care
<b>Address:</b>	8150 Wornall Road, Kansas City, MO 64114
<b>Contact:</b>	Dr. Angela Danley, Senior Director of Education Programs and Services
<b>Telephone:</b>	816-804-5599
<b>Email:</b>	<a href="mailto:angela.danley@cornerstonesofcare.org">angela.danley@cornerstonesofcare.org</a>
Cornerstones of Care is a Missouri nonprofit corporation and a public charity under IRC § 501(c)(3).	

### SERVICES AND COMPENSATION

<b>School Year:</b>	July 1, 2026-June 30, 2027	
<b>Services:</b>	Cornerstones of Care will provide training to teachers of Client in managing behavioral expectations involving students of Client. There will be five consultations per school (except the High School) during the year.	
<b>Compensation:</b>	Technology and administrative fees \$1,375 Client will pay \$29,500 to Cornerstones of Care for the Services.	
<b>Invoice(s):</b>	Invoice(s) will be submitted:	<input type="checkbox"/> Annually, on or before July 1, 2026
		<input type="checkbox"/> Semi-annually, on or before July 1, 2026 and January 1, 2027
		<input type="checkbox"/> Other _____

### AGREEMENT

Client agrees to engage Cornerstones of Care to provide and perform the Services, and Cornerstones of Care agrees to be so engaged and to provide and perform the Services, in accordance with this B.I.S.T Services Agreement ("Services Agreement") and the attached Terms and Conditions (together, "Agreement").

### SIGNATURES

<i>By signing below, the undersigned acknowledge that they have read and understand, and agree to be legally bound by, this Agreement.</i>	
<b>CLIENT</b>	<b>CORNERSTONES OF CARE</b>
By:	By: <i>Angela Danley</i>
Name: Jason Harris	Name: Dr. Angela Danley
Title: Director of Special Education	Title: Senior Director of Ed Programs & Services
Date:	Date: 3/2/2026

## TERMS AND CONDITIONS

### SECTION 1. SERVICES.

1.1 Independent Contractor Status. Cornerstones of Care is an independent contractor under this Agreement, and nothing herein creates, or will be construed to create, a partnership, joint venture, employer/employee or agency relationship between Cornerstones of Care and Client. Neither party will have the power or authority to enter into agreements of any kind on behalf of the other party, or to otherwise bind or obligate the other party in any manner to any third party.

1.2 Method of Performance. Cornerstones of Care will have the right to determine the method and means of providing and performing the Services. Client will be entitled, however, to exercise general power of supervision and control over the Services provided and performed by Cornerstones of Care and to inspect and approve those Services. Cornerstones of Care agrees to follow all reasonable suggestions or recommendations made by Client with respect to the provision and performance of the Services.

1.3 Taxes. Cornerstones of Care will be solely responsible for all federal, state and local taxes and related contributions attributable to the payments from Client to Cornerstones of Care for the Services rendered. Cornerstones of Care further acknowledges and agrees that Cornerstones of Care is an independent contractor for federal, state and local income and employment tax purposes, including FICA and FUTA, and will not be entitled to workers' compensation or other insurance protection or benefits provided by Client.

1.4 Background Checks. Cornerstones of Care will require each of its nonparty affiliates and third parties assisting Cornerstones of Care in performing under this Agreement to be subjected to criminal and child abuse and neglect background checks that include a complete fingerprint criminal record check ("Background Checks"). The results of the Background Check must be received and considered satisfactory by Cornerstones of Care before it permits any such nonparty affiliate or third party to have direct contact with students of Client receiving the Services ("Student"). Any record indicating a finding or plea of guilty to any felony, any crime involving abuse or neglect of children, or any sex offense or crime involving moral turpitude will not be considered a satisfactory Background Check.

1.5 Employment Eligibility. Cornerstones of Care will ensure that it and any nonparty affiliate engaged or assigned to provide and perform the Services has a completed a Form I-9 verification for each employee of Cornerstones of Care and the nonparty affiliate providing and performing the Services, and has determined that the employee is legally authorized to work in the United States through E-Verify or any other equivalent electronic verification of work authorization program operated by the United States Department of Homeland Security under the Immigration Reform and Control Act of 1986.

### SECTION 2. COMPENSATION, EXPENSES AND PAYMENT.

2.1 Compensation. In consideration of the Services rendered, Client will pay Cornerstones of Care compensation in the amount, and payable at the times and in the manner, set forth in the Services Agreement.

2.2 Reimbursement of Expenses. Client will not be obligated to reimburse Cornerstones of Care for or pay any charge, cost or expense incurred by Cornerstones of Care in connection with its provision and performance of the Services, exercise of its rights or performance of its obligations under this Agreement, or otherwise performing hereunder, including the costs associated with conducting Background Checks, unless specifically set forth in this Agreement.

2.3 Invoices. Cornerstones of Care will submit to Client invoices for the Services rendered in accordance with the schedule set forth in the Services Agreement. If the Services Agreement does not provide a schedule for the submission of invoices, invoices will be submitted annually. The invoices must describe the Services rendered and will list all reimbursable charges, expenses and costs on a pass-through basis.

Cornerstones of Care must include receipts or other appropriate documentation for the reimbursable charges, expenses and costs with the invoices. Invoices are payable within 30 days of receipt of invoice, unless otherwise provided in the Services Agreement.

### SECTION 3. TERM AND TERMINATION

3.1 Term. This Agreement is effective commencing on, and will terminate on, the beginning and ending dates, respectively, of the school year set forth in the Services Agreement, unless earlier terminated in accordance with Sections 3.2 or 3.3.

3.2 Termination upon Breach. Notwithstanding Section 3.1, either party may terminate this Agreement upon written notice to the other party in the event that the other party (i) materially breaches any obligation hereunder and either the breach cannot be cured or, if the breach can be cured, it is not cured within 10 days after written notice of the breach, or (ii) becomes insolvent, files a petition for bankruptcy or commences or has commenced against it proceedings relating to bankruptcy, receivership, reorganization or assignment for the benefit of creditors.

3.3 Termination Upon Non-appropriation. Subject to Section 4.2(b), if (i) Client is a governmental entity, (ii) this Agreement covers multiple fiscal years of Client, and (iii) no funds or insufficient funds are appropriated, budgeted or otherwise made available to support continuation of payments under Section 2.1, Client will immediately notify Cornerstones of Care of such occurrence and this Agreement will terminate automatically on the last day of the fiscal year for which sufficient funds were appropriated, budgeted or otherwise made available.

3.4 Effect of Termination. Upon any termination of this Agreement, (i) any and all rights and obligations of the parties under this Agreement will terminate, provided that Sections 1.3, 3.4, 4, 5, 6, 7 and 8, all rights, obligations or liabilities accrued hereunder prior to termination, and any other right, obligation or liability which by its nature or express duration extends beyond the termination of this Agreement, will survive termination and continue in effect indefinitely or for that express duration, and (ii) without limiting the foregoing, Cornerstones of Care will withdraw its personnel and equipment from Client's facilities, cease provision and performance of the Services, and turn over to Client any Work Product (as defined below) in process.

### SECTION 4. REPRESENTATIONS, WARRANTIES AND COVENANTS.

4.1 Cornerstones of Care. Cornerstones of Care represents, warrants and covenants to Client as follows:

(a) Performance. All of the Services will be provided and performed by Cornerstones of Care in a workmanlike manner, with professional diligence and skill, and using sound and professional principles and practices in accordance with normally accepted industry standards.

(b) No Infringement. To Cornerstones of Care's knowledge, no Work Product will infringe the rights of any third party under applicable law.

(c) No Conflict. Cornerstones of Care's execution and performance of this Agreement do not and will not violate the legal or contractual rights of any third party.

(d) Compliance. Cornerstones of Care will observe and comply with, and cause its nonparty affiliates and any third party who assists Cornerstones of Care in performing under this Agreement to observe and comply with, Client's policies notified in writing to Cornerstones and applicable law that apply to the provision and performance of the Services, including with respect to (i) maintenance and retention of records, (ii) non-discrimination on the basis of race, color, religion, sex, sexual orientation/gender identity, age, national origin, disability, veteran status or any other basis prohibited by applicable law, (iii) provision of a drug-free workplace, (iv) Background Checks, and (v)

confidentiality of Student Information, including pursuant to the Family Educational Rights and Privacy Act of 1974.

(e) Power and Authority; Binding Agreement. Cornerstones of Care has the power and authority to execute, deliver and perform this Agreement, which constitutes a valid and binding obligation of Cornerstones of Care, enforceable against Cornerstones of Care in accordance with its terms. Cornerstones is duly qualified to do business and is in good standing in the jurisdiction(s) in which the Services will be provided and performed. The individual signing this Agreement on behalf of Cornerstones of Care has been properly authorized and empowered to enter into, and bind Cornerstones of Care to, this Agreement.

(f) Insurance. Cornerstones of Care will procure and maintain in effect (i) worker's compensation insurance that complies with applicable law and provides appropriate coverage for the Services, and (ii) comprehensive general liability insurance, including automobile liability insurance, in a sum no less than \$1,000,000 per occurrence with an aggregate limit of \$2,000,000 with financially sound and reputable insurers licensed to conduct the business of insurance in the jurisdiction(s) in which the Services will be provided and performed. Upon Client's request, Cornerstones of Care will (i) provide Client with a certificate of insurance from Cornerstones of Care's insurer evidencing the required insurance coverage and provide 30 days' notice of cancellation or material change, and (ii) cause the insurance policies to be endorsed to include Client as an additional insured.

4.2 Client. Client represents, warrants and covenants to Cornerstones of Care as follows:

(a) Power and Authority; Binding Agreement. Client has the power and authority to execute, deliver and perform this Agreement, which constitutes a valid and binding obligation of Client, enforceable against Client in accordance with its terms. The individual signing this Agreement on behalf of Client has been properly authorized and empowered to enter into, and bind Client to, this Agreement.

(b) Appropriation. If Client is a governmental entity, Client represents and warrants that sufficient funds have been budgeted, appropriated and otherwise made available and a sufficient balance remains available for payment by Client under Section 2.1. If the term of this Agreement covers multiple fiscal years of Client, the foregoing representation and warranty will apply only to the first fiscal year.

4.3 No Other Representations or Warranties. EXCEPT FOR THE EXPRESS REPRESENTATIONS AND WARRANTIES CONTAINED IN THIS SECTION 4, (I) NEITHER PARTY TO THIS AGREEMENT, NOR ANY OTHER PERSON ON THE PARTY'S BEHALF, HAS MADE OR MAKES ANY EXPRESS OR IMPLIED REPRESENTATION OR WARRANTY, EITHER ORAL OR WRITTEN, WHETHER ARISING BY LAW, COURSE OF DEALING, COURSE OF PERFORMANCE, USAGE, TRADE, OR OTHERWISE, ALL OF WHICH ARE EXPRESSLY DISCLAIMED, AND (II) EACH PARTY ACKNOWLEDGES THAT IT HAS NOT RELIED UPON ANY REPRESENTATION OR WARRANTY MADE BY THE OTHER PARTY, OR ANY OTHER PERSON ON SUCH PARTY'S BEHALF, EXCEPT AS SPECIFICALLY PROVIDED IN THIS SECTION 4.

#### SECTION 5. CONFIDENTIALITY.

5.1 General. Cornerstones of Care will treat as confidential the Work Product, Student Information (as defined below) and any other information that may be disclosed, provided or made accessible by Client under this Agreement ("Confidential Information"). Without the express written consent of Client, Cornerstones of Care will not disclose Confidential Information to any third party, nor use that information, directly or indirectly, other than as contemplated by this Agreement. Notwithstanding the foregoing but subject to Section 5.2, Confidential Information does not include, and this Agreement imposes no obligation upon Cornerstones of Care with respect to, information that

Cornerstones of Care demonstrates (i) was in Cornerstones of Care's possession on a non-confidential basis before receipt from Client or any of its nonparty affiliates, (ii) has become generally available to the public other than as a result of disclosure by Cornerstones of Care or any of its nonparty affiliates, (iii) has become available to Cornerstones of Care on a non-confidential basis from a source other than Client or any of its nonparty affiliates, provided that the source is not known by Cornerstones of Care or any of its nonparty affiliates to be bound by a confidentiality agreement with Client or any of its nonparty affiliates, or otherwise prohibited from transmitting the information to Cornerstones of Care by a contractual, legal, fiduciary or other obligation, or (iv) which is required to be disclosed by judicial or administrative process, provided Cornerstones of Care must promptly notify Client and allow Client a reasonable time to oppose that process, if appropriate, in the sole discretion of Client.

5.2 Student Information. Cornerstones of Care will not disclose any patient, educational or medical record information regarding any Student ("Student Information") to any third party, except where permitted or required by applicable law, or where such disclosure is expressly approved in writing by Client, the Student (to the extent eligible) or a parent of the Student.

#### SECTION 6. INDEMNIFICATION; LIMITATION OF LIABILITY.

6.1 Indemnification. To the extent permitted by applicable law, each party will indemnify, hold harmless and defend the other party and its nonparty affiliates from and against, and will reimburse those indemnified persons with respect to, any and all claims, demands, causes of action, proceedings, losses, damages, debts, expenses, liabilities, fines, penalties, deficiencies, judgments or costs, including reasonable attorney fees, court costs, amounts paid in settlement, and costs and expenses of investigations, at any time and from time to time asserted against or incurred by any of those indemnified persons arising out of, in connection with, resulting from or by reason of (i) any breach of this Agreement by the indemnifying party, (ii) any negligent or more culpable act or omission of the indemnifying party or any of its nonparty affiliates in connection with the performance of its obligations under this Agreement, or (iii) any injury to an individual (including death) or damage to property caused by the indemnifying party or any of its nonparty affiliates.

6.2 Limitation of Liability. IN NO EVENT WILL EITHER PARTY BE LIABLE UNDER OR AS A RESULT OF THIS AGREEMENT, WHETHER IN CONTRACT, WARRANTY, TORT OR OTHERWISE, TO THE OTHER PARTY OR ANY OTHER PERSON CLAIMING THROUGH OR UNDER THE OTHER PARTY, FOR ANY SPECIAL, CONSEQUENTIAL, INCIDENTAL, INDIRECT, PUNITIVE OR OTHER SIMILAR DAMAGES, EVEN THOUGH ADVISED OR OTHERWISE AWARE OF THE POSSIBILITY OF THOSE DAMAGES, EXCEPT FOR THIRD-PARTY CLAIMS THAT ARE SUBJECT TO THE FOREGOING INDEMNIFICATION.

6.3 Claims Procedures; No Waiver of Immunity. If Client is a governmental entity, (i) this Section 6 is subject to the required administrative procedures and remedies in the event of a claim asserted against Client and (ii) Client preserves, and nothing in this Section 6 will be construed as a waiver by Client of, any sovereign or governmental immunity recognized by applicable law.

#### SECTION 7. CLIENT PROPERTY.

7.1 Work Product. All work product resulting or derived from, or made in the course of provision and performance of the Services, including any invention, research results, software program, and written material (collectively, "Work Product"), will be considered "work for hire" and, unless already in the public domain, all right, title, ownership and interest in items of Work Product will be vested exclusively in Client. Cornerstones of Care will promptly execute any and all documents and instruments as may be necessary to evidence, protect, perfect or

otherwise confirm Client's rights hereunder in respect of Work Product.

7.2 Other Client Property. Any and all equipment, tools, materials, records and data furnished to Cornerstones of Care by Client in connection with the provision and performance of the Services and any and all materials, records and data containing Confidential Information, including in each case all copies thereof regardless of form, format or medium, are and will remain the sole property of Client.

**SECTION 8. GENERAL PROVISIONS.**

8.1 Force Majeure. No party will be liable or responsible to the other party, or be considered to have breached this Agreement, for any failure or delay in fulfilling or performing any term of this Agreement (except for any obligations to make payments to the other party hereunder), when and to the extent such failure or delay is caused by or results from acts beyond the impacted party's reasonable control ("Force Majeure Event"). The impacted party will give notice within three days of the Force Majeure Event to the other party, stating the period of time the occurrence is expected to continue. The impacted party will use diligent efforts to end the failure or delay and ensure the effects of the Force Majeure Event are minimized. The impacted party will resume the performance of its obligations as soon as reasonably practicable after the removal of the cause of the Force Majeure Event.

8.2 Binding Nature of Agreement; Assignment. All the terms and provisions of this Agreement will be binding upon and will inure to the benefit of the parties and their respective successors, and permitted assigns. Cornerstones of Care may not assign or transfer to any third party any of its rights or obligations hereunder without the prior written consent of Client.

8.3 No Third Party Beneficiaries. The terms and provisions of this Agreement are intended solely for the benefit of each party and their respective successors and permitted assigns and it is not the intention of the parties to confer third-party beneficiary rights upon any other individual or entity.

8.4 No Exclusive Agreement. This is not an exclusive agreement. Client is free to engage others, and Cornerstones of Care is free to accept engagement by others, to provide and perform services the same as or similar to the Services.

8.5 Notices. All notices or other communications required or permitted under this Agreement must be in writing and will be considered given when delivered by (i) by overnight courier service, with proof of delivery; (ii) certified or registered mail, with proof of delivery; or (iii) by email, with confirmation of receipt, using the recipient party's address or email address set forth in the Services Agreement. A party may change its address or email address by notice to the other party in accordance with this section.

8.6 Entire Agreement. This Agreement contains the entire agreement between the parties with respect to the subject matter hereof, and supersedes all prior and contemporaneous agreements and understandings, inducements or conditions, express or implied, oral or written, with respect to that subject matter. The express terms hereof control and supersede any course of performance or usage of the trade inconsistent with any of the terms hereof. If any provision contained in the Services Agreement conflicts with any provision contained in these Terms and Conditions, the provision contained in the Services Agreement will govern.

8.7 Amendment. This Agreement may be amended and the terms hereof may be waived only by a written instrument signed by both parties or, in the case of a waiver, by the party waiving compliance.

8.8 No Waiver. No failure or delay by any party in exercising any

right, power or privilege hereunder will operate as a waiver of any right, power or privilege hereunder. No waiver of any default on any one occasion will constitute a waiver of any subsequent or other default. No single or partial exercise of any right, power or privilege will preclude the further or full exercise thereof.

8.9 Severability. The provisions of this Agreement will be considered severable, and the invalidity or unenforceability of any one or more of the provisions hereof will not affect the validity and enforceability of the other provisions hereof.

8.10 Remedies. Except as otherwise provided herein, the rights and remedies of the parties with respect to failure of a party to comply with the terms of this Agreement are not exclusive, the exercise thereof will not constitute an election of remedies and the aggrieved party will in all events be entitled to seek whatever additional remedies may be available in law or in equity.

8.11 Publicity. Neither party will use any trademark, name or logo of the other party in any publicity release, advertising or other promotional activity without the prior written consent of the other party.

8.12 Consent to Conduct Business Electronically. Either or both parties may use electronic records and electronic signatures for the execution and delivery of this Agreement and in connection with the matters contemplated by this Agreement. Except as otherwise specifically set forth in this Agreement, the parties may use and rely upon electronic records and signatures for all agreements, undertakings, notices, disclosures or other documents, communications or information of any type sent or received in accordance with this Agreement.

8.13 Construction; Additional Definitions. In interpreting and construing this Agreement, unless expressly stated herein to the contrary or the context requires otherwise: (i) all captions, headings and similar terms are for convenience of reference only; (ii) "herein," "hereof," "hereunder," "hereby" and similar terms refer to this Agreement as a whole; (iii) terms used in the plural include the singular and vice versa; (iv) reference to any document means the document as amended or modified and as in effect from time to time; (v) "including," "include," "includes" and variations thereof will be construed as if followed by the phrase "without limitation"; (vi) "or" and "any" have the inclusive meaning represented by the phrases "and/or" and "any or all", respectively; (vii) reference to an article, section, schedule or exhibit is to an article, section, schedule or exhibit, respectively, of this Agreement; (viii) "day" means "calendar day" and when calculating a period of time, the day that is the initial reference day in calculating the period will be excluded; (ix) "law" means any foreign, federal, state or local law, statute, standard, code, ordinance, rule, regulation, promulgation or any order by any governmental authority; (x) "governmental authority" means any government or governmental or regulatory body thereof, or political subdivision thereof, whether federal, state, local or foreign, or any agency, instrumentality or authority thereof, or any court or arbitrator (public or private); (xi) "party" and "parties" means each or all, as appropriate, of the persons who have executed and delivered this Agreement; (xii) "person" means any individual, sole proprietorship, partnership, corporation, joint venture, limited liability company, estate, trust, unincorporated organization, association or other entity or governmental authority; and (xiii) "nonparty affiliates" means, with respect to a party, the affiliates and the members, partners, stockholders, trustees, directors, managers, officers, employees, consultants, advisors representatives, agents and subcontractors, as applicable, of the party and its affiliates. This Agreement will be construed without regard to any presumption or rule requiring construction or interpretation against the party drafting an instrument or causing any instrument to be drafted.

To: Board of Education  
From: Leonard Kwapnioski  
CC: Dr. Kay  
Date: May 8 , 2026  
Re: MS GreaseTrap

I am writing to recommend that the Board of Education approve the contract for the **Middle School Grease Trap Replacement to MJ Mechanical** of Hastings for the amount of **\$19,610.00**.

Columbus Public Schools (CPS) received three competitive bids for this project, which are attached for your review. Please note the following details regarding the scope of work:

- **Scope:** The quoted pricing covers the full removal and replacement of the existing tank.
- **CPS Responsibility:** Upon completion of the replacement, CPS staff will handle the concrete pour-back to finish the site.
- **Project Costs:** Payments will come from the Districts' maintenance fund.

If needed, I can provide a more detailed briefing during our meeting on **Monday, May 18th**. In the meantime, please feel free to reach out via email if you have any questions.

Thanks

Leonard

## Columbus School Grease Interceptor



### Gentlemen:

MJ Mechanical, LLC is pleased to submit our proposal for the above referenced project. This proposal is in accordance with the plans and specifications prepared by CPS.

### OUR BID INCLUDES OR EXCLUDES THE ITEMS AS LISTED BELOW.

#### CLARIFICATIONS:

- All items either included or excluded are as a part of the Base Bid.
- Columbus Schools will pour new concrete around grease interceptor.
- Extra soil from excavation will be left on site and removed by others.

#### ITEMS INCLUDED:

- Labor and materials to cut and remove concrete around interceptor
- Disconnect and remove old interceptor
- Provide and install (1) Schier grease interceptor
- Equipment rental
- Travel expenses
- Sand

#### ITEMS EXCLUDED:

- All HVAC, Equipment and Piping Insulation
- Building Management, Certified Test and Balance
- Water, Sewer, Natural Gas Tap & Development Fees
- Saw Cut, Patch Walls, Ceilings, Floors, and Roofing
- Electrical Systems
- Structural Steel
- Fire Protection System
- Irrigation Piping System
- Utilities from 5' beyond the building
- Site Restoration
- Formed Concrete and/or pads
- Painting
- Temporary Heat, Cooling, Water, Gas, Storm, or Sanitary Piping
- Asbestos Identification, Removal/Abatement
- Ground Thaw Equipment Install and Removal
- Dumpster
- Pipe Enclosures
- Dewatering



- Protection of Existing Floor Coverings
- Ceiling Tile Removal/Replacement
- Dust Protection
- Final Cleaning
- Performance/Payment Bond
- Utility Locates
- Seismic Bracing
- Sound Caulking
- Davis Bacon Wages
- Smoke Detectors
- Overtime Wages

### **GENERAL CONDITIONS TO THIS PROPOSAL:**

- This proposal includes sales tax for all materials if applicable.
- This contractor shall not be held liable for errors or omissions in designs by others, nor inadequacies of materials and equipment specified or supplied by others.
- Equipment and materials supplied by the contractor are warranted only to the extent that the same is warranted by the manufacturer.
- *Warranties shall apply exclusively to the mechanical installation of the material, fixtures, equipment, and other items supplied by the mechanical contractor.*
  - Warranty does not apply to:*
    - Material, fixtures, equipment and other items supplied by others.
    - Extensions or additions to the original installation if made by other parties.
- Mechanical installation shall meet the Uniform Plumbing Code and local building codes. Errors in design by the architect and/or engineer are not the responsibility of MJ Mechanical, LLC. Any additional piping, fixtures, equipment, etc. not indicated on plans and specifications that are required by other (i.e., Inspectors) shall not be part of this proposal.
- This contractor shall not be liable for indirect loss or damage.
- Mechanical contractor carries Workmen's Compensation and Professional Liability Insurance covering its work on this job. Owner/contractor agrees to notify his/her insurance company of the commencement of work. Risk of loss due to fire, windstorm, vandalism, or other casualty shall be the responsibility of the owner/contractor.
- Unless specifically included in this proposal, all bonding and/or special insurance requirements are supplied at additional cost.
- MJ Mechanical prides itself on providing a safe work environment for its employees as well as the persons in our work environment. Safety work practices are bid according to OSHA 1926 regulations for construction and OSHA 1910 regulations for general industry. Unless specifically included in this proposal, all jobsite safety regulations, rules, or policies that exceed these OSHA regulations are supplied at additional cost.
- Anything (verbal or written) expressed or implied elsewhere, which is contrary to these conditions shall be null and void.
- Any alterations or deviation from the above specifications involving extra cost of material or labor will only be executed upon written orders for same and will become an extra charge over the sum mentioned in this contract.

Agreements must be made in writing.  
This proposal expires in 30 days.



**BASE BID: \$19,610.00 100 GPM**

**BASE BID: \$16,450.00 75 GPM**

**ADD FOR BOND: 1.5%**

Brandon Garcia  
402-984-0624  
[bgarcia@mjmechanicalne.com](mailto:bgarcia@mjmechanicalne.com)

Location: \_\_\_\_\_



# BIG-750

## BIG MAX® HYDRO MECHANICAL GREASE INTERCEPTOR - 75 GPM



Option 1 75GPM

**Specification:** MIFAB® Series BIG-750 hydro mechanical grease interceptor with flow rating of 75 GPM and grease holding capacity of 838 lbs. Interceptor has a limited lifetime warranty and is made in the USA out of seamless, rotationally molded High Density Polyethylene with 3/8" uniform wall thickness. Interceptor is designed for above or below ground installation and includes extension pipe gasket for ADS 18N12 (pipe not included) for the adjustable lid system, sample port access, internal baffle, deep seal trap covered by lid, internal flow control set to 75 GPM and 4" no hub inlet and outlet connections. Ductile iron pickable lids, H-20 rated, proof-load tested to 40,000 lbs. provide a water / gas tight seal. The lids are designed in accordance with the loading requirements of AASHTO H-20. The high density polyethylene material is PE 3135 from Dow 9.39 with a density of 0.939 g/cm3. Note that the interceptor is tested and certified to the ASME A112.14.3 Standard (Type D), CSA B481 and listed with I.A.P.M.O. For indoor / outdoor use. The -PDI model is tested and certified to the PDI G-101 Standard.

**Function:** Used in restaurants, kitchens, institutional and industrial facilities such as food processing and packaging plants and other types of food processing areas where fat, oil and grease (FOG) drains with the waste water. Typically installed either on or into the floor. Narrow width permits access through doorways and down stairwells. High Density Polyethylene construction ensures a lightweight installation process (two people can move and install it). Regular maintenance is required to keep the interceptor functioning. BIG-750 interceptor can withstand a temperature of up to and including 150° Fahrenheit.

**NOTES:**

1. 4" No Hub inlet and outlet
2. Shipping weight: 150 lbs.
3. Operating temperature: 150° F
4. Capacities:
  - Liquid: 140 gal. (18.6 cu.ft.);
  - Grease: 564 lbs. (37.7 gal.) @50GPM (Type D)
  - Grease: 838 lbs. (114.1 gal.) @75GPM (Type D)
  - Solids: 63 gal.
5. Do not use for pressure applications.
6. Cover placement allows full access to tank for proper maintenance.
7. Vent required per local code.
8. Engineered inlet and outlet diffusers with inspection ports are removable to inspect/clean piping.
9. Designed for below-grade, above-grade, indoor or outdoor installations.
10. Meets PDI G-101 Standard when installed with external, vented flow control fitting.

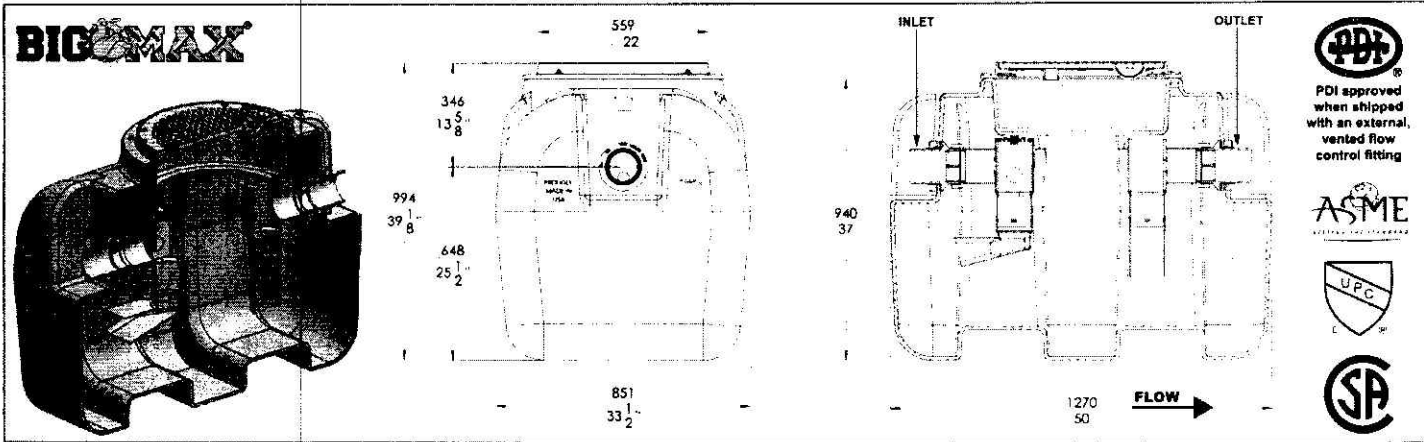

**SUFFIX**

- AK Anchor kit (set of two) for BIG-750
- C Lid Extension - up to 44" high - for BIG-500 and BIG-750
- C Lid Extension - up to 72" high - for BIG-500 and BIG-750
- C Lid Extension - up to 94" high - for BIG-500 and BIG-750
- DS Dosing Pump for Lil Max, Big Max, SuperMax (includes the -EP enzyme port)
- EP Enzyme port for Lil Max, Big Max, SuperMax
- F6 6" no hub inlet and outlet
- FL-C Membrane clamp kit for BIG-500 and BIG-750
- HLA High level alarm and float switch (to be installed on site) (for Lil Max, Big Max, SuperMax)
- HLA2 High level alarm and dual float switch (to be installed on site) (for Lil Max, Big Max, SuperMax)
- HLAW High level alarm and dual float switch with wifi capability (to be installed on site) (for Lil Max, Big Max, SuperMax)
- LHSI No hub inlet on left hand side (not available with sediment bucket) (for Lil Max, Big Max, SuperMax)
- LHSO No hub outlet on left hand side (not available with sediment bucket) (for Lil Max, Big Max, SuperMax)
- PDI PDI plate and external, vented flow control fitting (to meet PDI G-101 Standard)
- POK Remote pump out kit (specify location and number required)
- RHSI No hub inlet on right hand side (not available with sediment bucket) (for Lil Max, Big Max, SuperMax)
- RHSO No hub outlet on right hand side (not available with sediment bucket) (for Lil Max, Big Max, SuperMax)
- RPO 3" Remote pump outlet connections on top of interceptor - specify location and number required
- SB Sediment bucket - for BIG-750
- SP External sampling port with 27" dia. ductile iron pickable cover, inline connections
- SP-OFF External sampling port with 27" dia. ductile iron pickable cover, offset connections
- SAMPORT Compact external sampling port with 10" dia. access cover and offset connections
- STR Safety shield for Big Max
- T Female threaded connections (2 pcs. Included)

**OPTIONAL VARIATIONS**

**PART NO.**

- BIG-750-AK-SET
- BIG-750-EXT-44
- BIG-750-EXT-72
- BIG-750-EXT-94
- XL-MI-PL-DP
- XL-MI-PL-EP
- MI-G-PL-PF6 (2 pcs. required)
- BIG-750-PFLM
- XL-MI-PL-HLA
- XL-MI-PL-HLA2
- XL-MI-PL-HLAW
- MI-G-PL-PF4
- MI-G-PL-PF4 -PDI
- BIG-MAX-POK
- MI-G-PL-PF4
- MI-G-PL-PF4
- BIG-MAX-RPO
- BIG-750-PSB
- BIG-SP
- BIG-SP-OFF
- SAMPORT
- BIG-STR
- MI-G-PL-PF4T

CALIFORNIA PROPOSITION 65 WARNING. This product contains chemicals known to the State of California to cause cancer and birth defects or other reproductive harm.

Job Name:  Page No: \_\_\_\_\_

Section No: \_\_\_\_\_ Contractor: \_\_\_\_\_

Schedule No: \_\_\_\_\_ Purchase Order No: \_\_\_\_\_

Location: \_\_\_\_\_



# BIG-1150

## BIG MAX® HYDRO MECHANICAL GREASE INTERCEPTOR - 100 GPM



**Specification:** MIFAB® Series BIG-1150 hydro mechanical grease interceptor with flow rating of 100 GPM and grease holding capacity of 2,016 lbs. Interceptor has a limited lifetime warranty and is made in the USA out of seamless, rotationally molded High Density Polyethylene with 3/8" uniform wall thickness. Interceptor is designed for above or below ground installation and includes extension pipe gasket for ADS 18N12 (pipe not included) for the adjustable lid system, sample port access, internal baffle, deep seal trap covered by lid, internal flow control set to 100 GPM and 4" no hub inlet and outlet connections. Ductile iron pickable lids, H-20 rated, proof-load tested to 40,000 lbs. provide a water / gas tight seal. The lids are designed in accordance with the loading requirements of AASHTO H-20. The high density polyethylene material is PE 3135 from Dow 9.39 with a density of 0.939 g/cm3. Note that the interceptor is tested and certified to the ASME A112.14.3 Standard (Type D), CSA B481 and listed with I.A.P.M.O. For indoor / outdoor use. The -PDI model is tested and certified to the PDI G-101 Standard.

**Function:** Used in restaurants, kitchens, institutional and industrial facilities such as food processing and packaging plants and other types of food processing areas where fat, oil and grease (FOG) drains with the waste water. Typically installed either on or into the floor. Narrow width permits access through doorways and down stairwells. High Density Polyethylene construction ensures a lightweight installation process (two people can move and install it). Regular maintenance is required to keep the interceptor functioning. BIG-1150 interceptor can withstand a temperature of up to and including 150° Fahrenheit.

**NOTES:**

1. 4" No Hub inlet and outlet
2. Shipping weight: 275 lbs.
3. Operating temperature: 150° F
4. Capacities:
  - Liquid: 300 gal.(40 cu.ft.);
  - Grease: 1812 lbs. (246.7 gal.) @75GPM (Type D) (BIG-1150-99) (Miami-Dade DERM approved at 99% efficiency)
  - Grease: 2,016 lbs. (274.5 gal.) @100GPM (Type D) (Type C) (BIG-1150)
  - Grease: 1,515 lbs. (206.3 gal.) @ 200GPM (Type D) (BIG-1150-D-200)
  - Solids: 135 gal.
5. Do not use for pressure applications.
6. Cover placement allows full access to tank for proper maintenance.
7. Vent required per local code.
8. Engineered inlet and outlet diffusers with inspection ports are removable to inspect/clean piping.
9. Designed for below-grade, above-grade, indoor or outdoor installations.
10. Meets PDI G-101 Standard when installed with external, vented flow control fitting.

Option 2 100 GPM

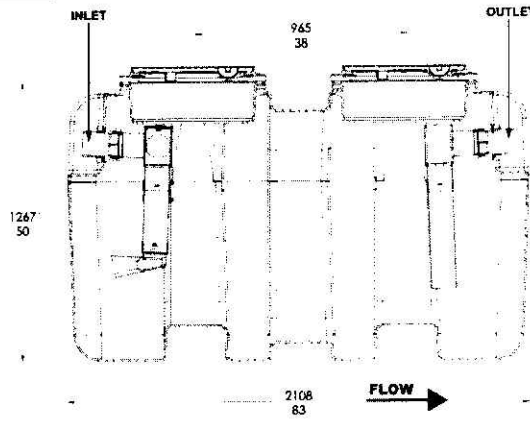
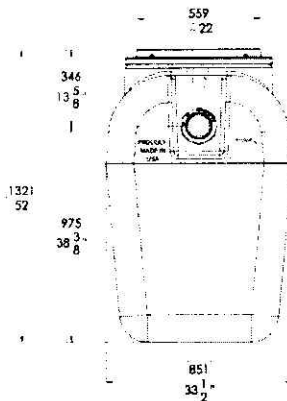
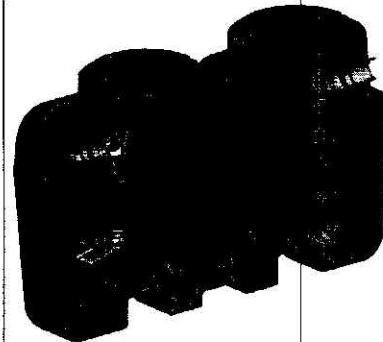

SUFFIX	OPTIONAL VARIATIONS	PART NO.
-AK	Anchor kit (set of two) for BIG-1150	BIG-1150-AK-SET
-C	Lid Extension - up to 44" high - for BIG-1150	BIG-1150-EXT-44 (2 pcs. Incl.)
-C	Lid Extension - up to 72" high - for BIG-1150	BIG-1150-EXT-72 (2 pcs. Incl.)
-C	Lid Extension - up to 94" high - for BIG-1150	BIG-1150-EXT-94 (2 pcs. Incl.)
-DS	Dosing Pump for Lil Max, Big Max, SuperMax (includes the -EP enzyme port)	XL-MI-PL-DP
-EP	Enzyme port for Lil Max, Big Max, SuperMax	XL-MI-PL-EP
-F6	6" no hub inlet and outlet	MI-G-PL-PF6 (2 pcs. required)
-FL-C	Membrane clamp kit for BIG-1150 (2 pcs. Included)	BIG-1150-PFLM (2 pcs. Included)
-HLA	High level alarm and float switch (to be installed on site) (for Lil Max, Big Max, SuperMax)	XL-MI-PL-HLA
-HLA2	High level alarm and dual float switch (to be installed on site) (for Lil Max, Big Max, SuperMax)	XL-MI-PL-HLA2
-HLAW	High level alarm and dual float switch with wifi capability (to be installed on site) (for Lil Max, Big Max, SuperMax)	XL-MI-PL-HLAW
-LHSI	No hub inlet on left hand side (not available with sediment bucket) (for Lil Max, Big Max, SuperMax)	MI-G-PL-PF4
-LHSO	No hub outlet on left hand side (not available with sediment bucket) (for Lil Max, Big Max, SuperMax)	MI-G-PL-PF4
-PDI	PDI plate and external, vented flow control fitting (to meet PDI G-101 Standard)	-PDI
-POK	Remote pump out kit (specify location and number required)	BIG-MAX-POK
-RHSI	No hub inlet on right hand side (not available with sediment bucket) (for Lil Max, Big Max, SuperMax)	MI-G-PL-PF4
-RHSO	No hub outlet on right hand side (not available with sediment bucket) (for Lil Max, Big Max, SuperMax)	MI-G-PL-PF4
-RPO	3" Remote pump outlet connections on top of interceptor - specify location and number required	BIG-MAX-RPO
-SB	Sediment bucket - for BIG-1150	BIG-1150-PSB
-SP	External sampling port with 27" dia. ductile iron pickable cover, inline connections	BIG-SP
-SP-OFF	External sampling port with 27" dia. ductile iron pickable cover, offset connections	BIG-SP-OFF
-SAMPOR	Compact external sampling port with 10" dia. access cover and offset connections	SAMPOR
-STR	Safety shield for Big Max	BIG-STR
-T	Female threaded connections (2 pcs. Included)	MI-G-PL-PF4T

CALIFORNIA PROPOSITION 65 WARNING. This product contains chemicals known to the State of California to cause cancer and birth defects or other reproductive harm.

Job Name: Columbus School

Page No: \_\_\_\_\_

Section No: \_\_\_\_\_

Contractor: \_\_\_\_\_

Schedule No: \_\_\_\_\_

Purchase Order No: \_\_\_\_\_



Helm Mechanical  
10901 "I" Street  
Omaha, NE 68137  
402-331-8420  
www.helmgroup.com

REVISION: 0

4-13-2026

ATTN: Leonard Kwapnioski  
John Harger

RE: Columbus Middle School Grease Interceptor Replacement  
Helm quote #OD-26-085

HELM MECHANICAL is pleased to provide the following proposal for the MECHANICAL scopes for the above-mentioned project.

**GENERAL SCOPE INCLUSIONS:**

- 1. Sawcut & Removal of existing Grease Interceptor.
- 2. Labor, Material & New Grease Interceptor Install.
- 3. Standard 1-year Craftmanship Warranty

**Exclusions:**

- |   |  |
|---|--|
| <ul style="list-style-type: none"> <li>1. Bonds, permits, or allowances</li> <li>2. Utility fees/Capital Facilities Fees</li> <li>3. MBE/WBE or workforce requirements</li> <li>4. Concrete work of any type (i.e. equipment pads, grouting)</li> </ul> | <ul style="list-style-type: none"> <li>5. Seismic restraints / seismic calculations</li> <li>6. Equipment warranty extension past manufacturer's standard warranty</li> <li>7. Painting of any kind</li> <li>8. Anchorage testing</li> </ul> |
|---|--|

**Notes:**

- *The pricing provided includes current market pricing. However, all tariffs, any other action by government authorities, and/or unforeseen commodity pricing impacts (such as production and/or inventory impacts) that cause any material cost increase between the proposal date and the actual material purchase date will be considered a reimbursable cost. Similarly, we reserve the right to update pricing and/or renegotiate the schedule without penalty if there is an impact on any material availability.*
- This proposal is valid for 30 days from the date of the proposal, after which time it is subject to review & confirmation.
- All ductwork fabricated to current SMACNA duct construction standards.
- Construction drawings, in .dwg format, provided to us at no cost. All addenda & pre-contract RFI items shall be integrated into the files prior to release to us.
- Temporary sanitation facilities and OSHA approved temp lighting & power provided by others.
- Structural members shall be designed to carry MEP hanger loads. No special hangers or supplemental steel is included.
- Dumpsters for our use shall be provided by others.
- Terms: monthly progress payments, payable Net 30. Payments allowed for stored material either on jobsite, at shop, or at insured warehouse.

**BASE BID FOR THE ABOVE SCOPE OF WORK ..... \$21,362.00**

If you have any questions or need additional information, please feel free to contact me.

Sincerely,

Derek Carey  
[Dcarey@HelmGroup.com](mailto:Dcarey@HelmGroup.com)  
402-278-0386



**SPECIFICATION NOTES**

- (1) 4" FPT inlet/outlet with 4" plain end fittings
- (2) Unit weight: 236 lbs. For wet weight, add 2,310 lbs. For traffic-rated cover(s), add 90 lbs per cover. For pedestrian cover(s), add 7 lbs per cover.
- (3) Maximum operating temperature: 150° F continuous
- (4) Liquid Capacity: 277 gal  
Grease Capacity (100 GPM): 1,895 lbs (260 gal)  
Grease Capacity (150 GPM): 1,848 lbs (253 gal)  
Solids Capacity: 69 gal
- (5) Factory Rating:  
Grease Capacity (250 GPM): 500 lbs (68 gal)
- (6) For gravity drainage applications only
- (7) Do not use for pressure applications
- (8) Cover placement allows full access to tank for proper maintenance
- (9) Vent not required unless per local code
- (10) Engineered inlet and outlet diffusers with inspection ports are removable to inspect / clean piping
- (11) Integral air relief / Anti-siphon / Sampling access
- (12) Cover adapters provide an adjustable height range of 5"
- (13) Designed for below-grade, above-grade, indoor or outdoor installations
- (14) Safety Star® (450 lbs load capacity) is an access restrictor built into each cover adapter to prevent accidental entry into tanks

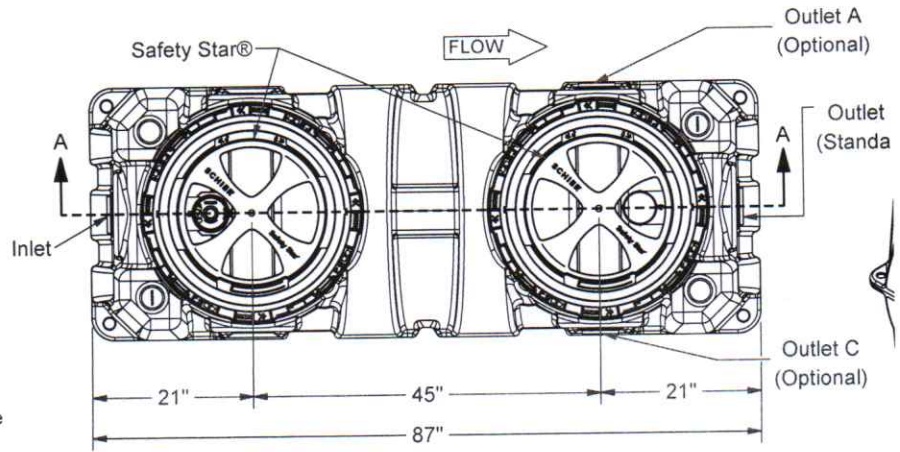

**TOP VIEW**  
(COVER(S) REMOVED FOR CLARITY)

Adjustable cover adapters v temporary cover; replace cover after finish installat

**CERTIFIED PERFORMANCE**

Great Basin® hydromechanical grease interceptors are third party performance-tested and listed by IAPMO to ASME A112.14.3 and CSA B481.1 grease interceptor standards and greatly exceed requirements for grease separation and storage. They are compliant to the Uniform Plumbing Code and the International Plumbing Code.

**ENGINEER SPECIFICATION GUIDE**

Schier Great Basin® grease interceptor model GB-250 shall be lifetime guaranteed and made in USA of seamless, molded polyethylene with minimum 3/8" uniform wall thickness. Interceptor shall be furnished for above or below-grade installation with adjustable cover adapter, Safety Star® access restrictor built into each cover adapter, and three outlet options. This unit is certified for hydromechanical performance to ASME A112.14.3 (Type D) and CSA B481.1. Interceptor flow rate shall be 100 GPM or 150 GPM. Interceptor grease capacity shall be 1,895 lbs @100 GPM or 1,848 lbs @150 GPM.

**COVERS SOLD SEPARATELY**

This unit is provided with temporary cover(s) intended for the duration of jobsite installation. Purchase one of the following finish covers.

- T24-GI (8044-000-01): Traffic-rated (AASHTO H-20) cast iron cover shall provide water/gas-tight seal and have a minimum of 16,000 lbs load capacity. For outdoor installation.
- P24-GI (8045-000-01): Pedestrian-rated poly cover shall provide water/gas-tight seal and have a minimum of 2,000 lbs load capacity. For indoor installation.

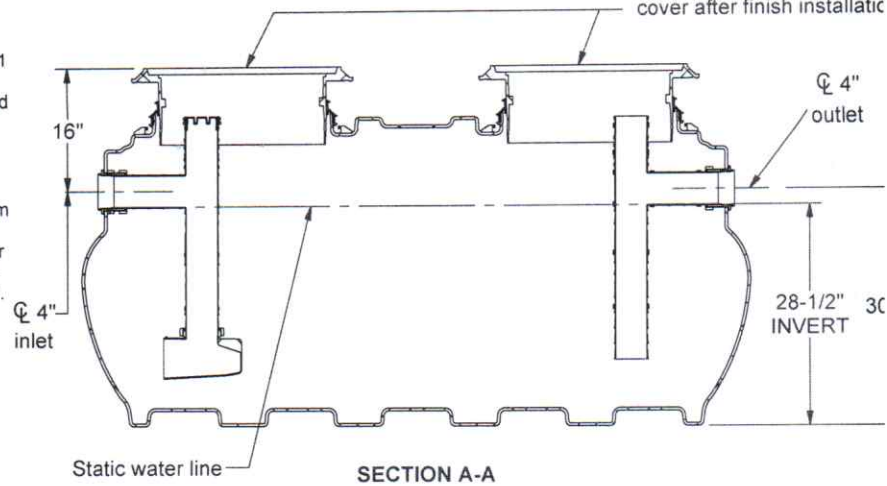

**SECTION A-A**

<p><b>SCHIER</b></p> <p>6455 Woodland Dr Shawnee, KS 66218</p> <p>tel: 913-951-3300 fax: 913-951-3399</p> <p>schierproducts.com</p> <p>Made in the U.S.A.</p>	MODEL NUMBER	<b>GB-250</b>		
	PART NUMBER	4055-300-02		
	DESCRIPTION	GB-250 GREASE INTERCEPTOR 100 GPM, 150 GPM, 4" PLAIN/FPT CONNECTIONS		
	DRAWN BY	G. HEIDE		
	DATE	2/25/2026	REV	A

# MIDLANDS MECHANICAL, INC.

8425 Wirt Street Omaha, NE 68134

TO: John Harger

DATE: 3/24/2026

INVOICE #: \_\_\_\_\_

PROJECT: Grease Intercptr 100

MMI JOB #:	TERMS:	CUSTOMER P.O. #:	AMOUNT
1123001	NET 10 DAYS		
Description Of Work			
Removal of old Grease Int outside Add a new Grease Int 100 GPM Add Clean outs to both sides for code Include Mini Ex and Skid Steer Include backfilling if needed Does not include concrete cutting removal and repouring Does not include the vacuuming of old Grease Int Does not include the offsite removal on Grease Int Does not include OT			
TOTAL AMOUNT DUE THIS BILLING			\$ 29,162.00

*Process Piping • HVAC • Plumbing*

<b>VENDOR</b>	<b>DESCRIPTION</b>	<b>PAGE</b>
Schier Products	100 GPM Grease Interceptor	7
Schier Products	Traffic Rated 24" Cast Iron Cover	8

**SPECIFICATION NOTES**

- (1) 4" FPT inlet/outlet with 4" plain end fittings
- (2) Unit weight: 236 lbs. For wet weight, add 2,310 lbs. For traffic-rated cover(s), add 90 lbs per cover. For pedestrian covers, add 7 lbs per cover.
- (3) Maximum operating temperature: 150° F continuous
- (4) Liquid Capacity: 277 gal  
Grease Capacity (100 GPM): 1,895 lbs (260 gal)  
Grease Capacity (150 GPM): 1,848 lbs (253 gal)  
Solids Capacity: 69 gal
- (5) Factory Rating:  
Grease Capacity (250 GPM): 500 lbs (68 gal)
- (6) For gravity drainage applications only
- (7) Do not use for pressure applications
- (8) Cover placement allows full access to tank for proper maintenance
- (9) Vent not required unless per local code
- (10) Engineered inlet and outlet diffusers with inspection ports are removable to inspect / clean piping
- (11) Integral air relief / Anti-siphon / Sampling access
- (12) Cover adapters provide an adjustable height range of 5"
- (13) Designed for below-grade, above-grade, indoor or outdoor installations
- (14) Safety Star® (450 lbs load capacity) is an access restrictor built into each cover adapter to prevent accidental entry into tanks

**CERTIFIED PERFORMANCE**

Great Basin® hydromechanical grease interceptors are third party performance-tested and listed by IAPMO to ASME A112.14.3 and CSA B481.1 grease interceptor standards and greatly exceed requirements for grease separation and storage. They are compliant to the Uniform Plumbing Code and the International Plumbing Code.

**ENGINEER SPECIFICATION GUIDE**

Schier Great Basin® grease interceptor model GB-250 shall be lifetime guaranteed and made in USA of seamless, molded polyethylene with minimum 3/8" uniform wall thickness. Interceptor shall be furnished for above or below-grade installation with adjustable cover adapter, Safety Star® access restrictor built into each cover adapter, and three outlet options. This unit is certified for hydromechanical performance to ASME A112.14.3 (Type D) and CSA B481.1. Interceptor flow rate shall be 100 GPM or 150 GPM. Interceptor grease capacity shall be 1,895 lbs @100 GPM or 1,848 lbs @150 GPM.

**COVERS SOLD SEPARATELY**

This unit is provided with temporary cover(s) intended for the duration of jobsite installation. Purchase one of the following finish covers.

- T24-GI (8044-000-01): Traffic-rated (AASHTO H-20) cast iron cover shall provide water/gas-tight seal and have a minimum of 16,000 lbs load capacity. For outdoor installation.
- P24-GI (8045-000-01): Pedestrian-rated poly cover shall provide water/gas-tight seal and have a minimum of 2,000 lbs load capacity. For indoor installation.

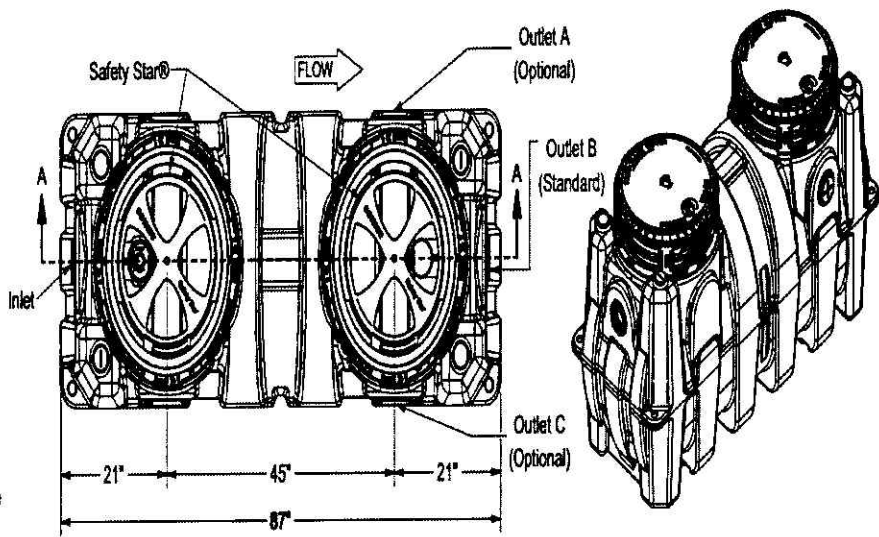

**TOP VIEW**  
(COVER(S) REMOVED FOR CLARITY)

**ISOMETRIC VIEW**

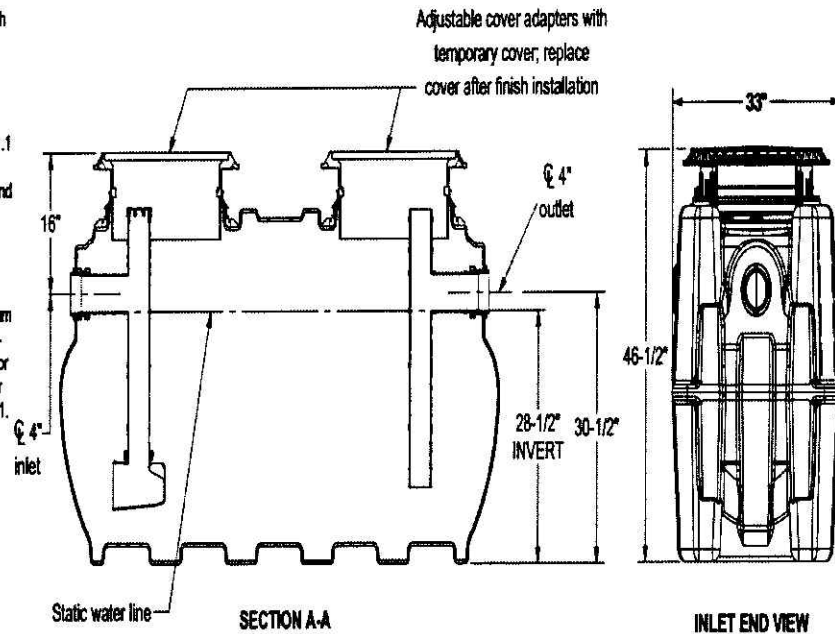

**SECTION A-A**

**INLET END VIEW**

**SPECIFICATION SHEET**

<p><b>SCHIER</b></p> <p>6455 Woodland Dr Shawnee, KS 66218</p> <p>tel: 913-951-3300 fax: 913-951-3399</p> <p>schierproducts.com</p> <p>Made in the U.S.A.</p>	MODEL NUMBER	<b>GB-250</b>		
	PART NUMBER	4055-300-02		
	DESCRIPTION	GB-250 GREASE INTERCEPTOR 100 GPM / 150 GPM, 4" PLAIN/FPT CONNECTIONS		
	DRAWN BY	G.HEIDE		
	DATE	2/25/2026	REV	A

PROPRIETARY AND CONFIDENTIAL. THE INFORMATION CONTAINED IN THIS DRAWING IS THE SOLE PROPERTY OF SCHIER PRODUCTS. ANY REPRODUCTION IN PART OR AS A WHOLE WITHOUT THE WRITTEN PERMISSION OF SCHIER PRODUCTS IS PROHIBITED.

# SPECIFICATION AND INSTALLATION GUIDE



Failure to follow  
this guidance will  
void your warranty

## T24-GI Traffic rated 24" cast iron cover

For use with grease interceptors models GB-50, GB-75, GB-250, GB-500, GB-1000 and GB-1500; solids interceptors models SI-50, SI-75, SI-250 and SI-500; inspection port models SV24 and SV24-O.

Unit weight: 91 lbs.

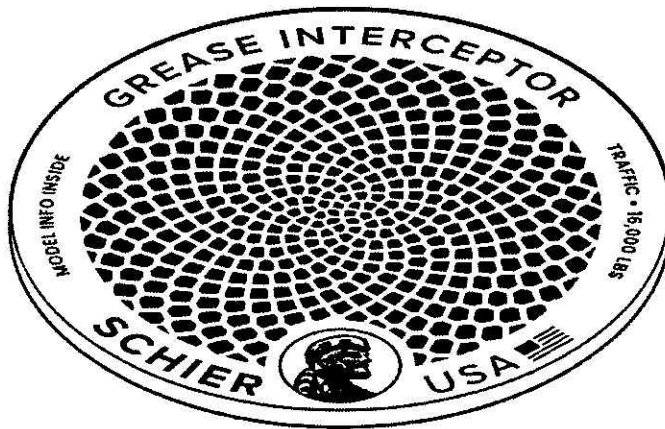

### SECTION VIEW

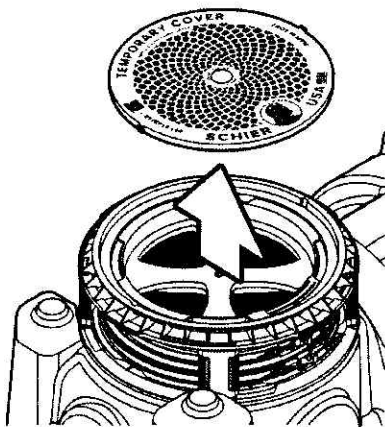
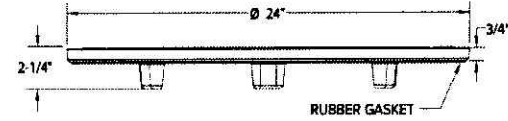

#### Replace temporary cover

Base tank models ship from the factory with temporary (jobsite only) cover(s) effective July 14, 2025. The T24-GI cover is sold separately from the base model (grease interceptor, solids interceptor or inspection port) and shall be applied by contractor during finish installation.

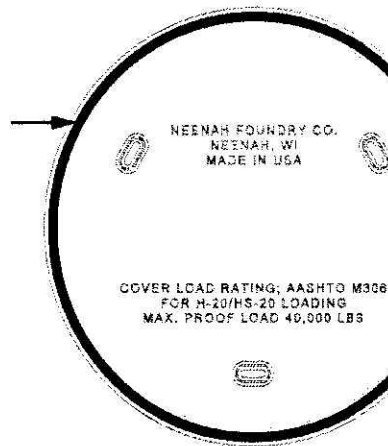

#### Gasket

The T24-GI includes a gasket on the bottom side that ensures a gas/water tight seal.

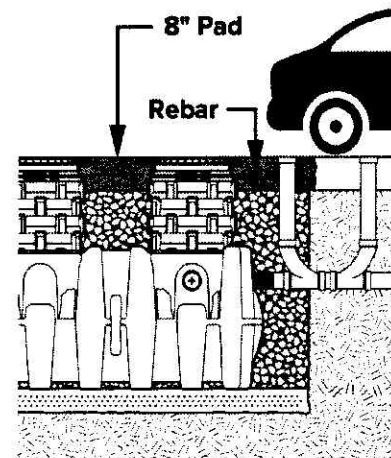

#### Buried installation

Choose T24-GI for buried installations where H-20 loads are required. H-20 rated to 16,000 lbs. per AASHTO M306.



**SCHIER**

MODEL NUMBER:

**T24-GI**

DESCRIPTION: Cover, 24in traffic rated, grease Interceptor system

PART #: 8044-000-01

DATE: 07/07/2025

REV:

ECO:

**To:** Board of Education  
**From:** Leonard Kwapnioski  
**CC:** Dr. Kay  
**Date:** May 8, 2026  
**Re:** MS Raised Planters

It is my recommendation that the Board of Education consider approving the **MS East Entrance Raised Planters to Platte Valley Precast from Columbus** for the removal and replacement with concrete in the amount of \$18,000 plus \$205.00 per bollard

Columbus Public Schools (CPS) received three competitive bids for this project, which are attached for your review. Please note the following details regarding the scope of work:

- **Scope:** The quoted pricing covers the full removal and replacement of the existing planters with concrete. The total number of bollards will be determined once planters are removed and distance from drive is agreed upon. Quantity should not exceed 12.
- **Project Costs:** Payment will come from the Districts' Maintenance Fund.

If needed, I can provide a more detailed briefing during our meeting on **Monday, May 18th**. In the meantime, please feel free to reach out via email if you have any questions.

Thanks

Leonard

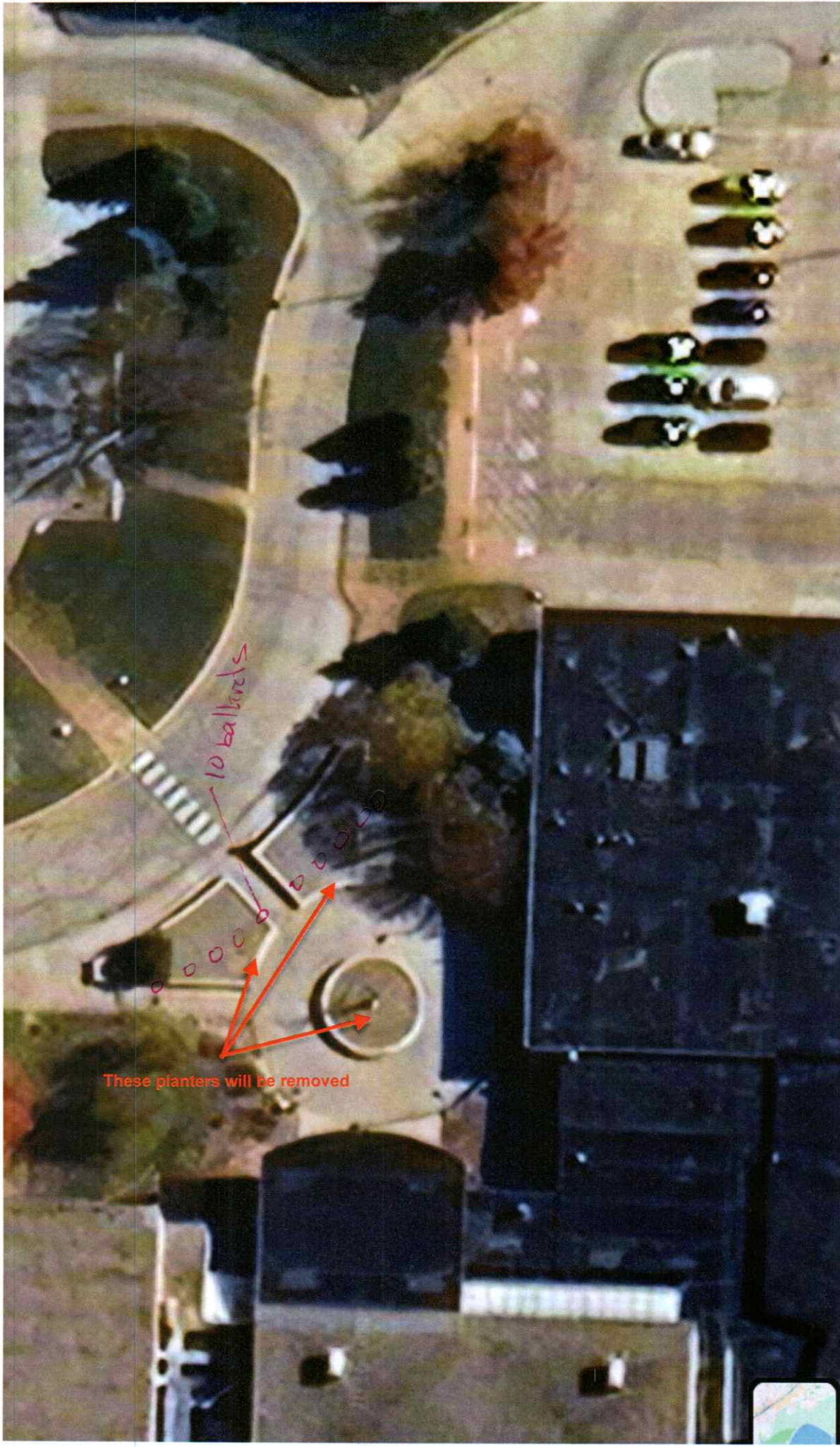

10 ball barrels

These planters will be removed



2670 54th Ave.  
Columbus, NE 68601

# Estimate

P (402) 564-9680 / F (402) 564-6928

E info@plattevalleyprecast.com

DATE	ESTIMATE NO.
5/4/2026	9979

NAME / ADDRESS
Columbus Public Schools 2508-27th St. Columbus, NE 68601

Project

QTY	DESCRIPTION	COST	TOTAL
	Demo of walls, removal of dirt inside, and repouring of concrete slab fill in.  Price per 4" bollard - \$185.00 Price per 6" bollard - \$205.00	18,000.00	18,000.00
<b>TOTAL</b>			\$18,000.00

SIGNATURE \_\_\_\_\_



**CONTRACTING, INC**  
ENGINEERING & CONSTRUCTION

Phone:402-564-4749 • Fax:402-564-4658

P.O. Box 1887 • 2560 E 29th Ave.  
Columbus, NE 68601

## ESTIMATE

**CUSTOMER**

NAME Columbus Public Schools  
 ADDRESS 2410 16th Street Suite A, PO Box 947  
 CITY Columbus STATE NE ZIP 68601  
 ATTENTION Mike Grutsch

**MISC**

DATE 5/6/2026  
 CONTACT Matt Heavican

DESCRIPTION	COST
<p><b>Project Location:</b>            Columbus Middle School            2200 26th Street, Columbus, NE 68601</p> <p><b>Project Description:</b>            East Entrance - Removal of (3) existing masonry planters and infilling the planter areas with concrete sidewalk to blend in with adjacent sidewalk.</p> <p><b>Demolition Included in Scope:</b>            Removing and hauling off approximately 323 Lf x 2' tall existing masonry wall            Removing and hauling off dirt and rock in planter boxes            Removal of tree ornament and concrete pedestal</p> <p><b>Concrete Infill Included in Scope:</b>            Infill approximately 1,927 SF of concrete sidewalk            6" thick concrete / Ready mix to be 3500 psi with 10 % limestone / #4 x 18" dowel bars at 30" on center into existing adjacent sidewalks</p> <p><b>Exclusions:</b>            Rebar mat reinforcement / Footing removals / Grinding or chipping down footings - estimate assumes that removal of masonry wall will allow for adequate concrete coverage / Repairs to existing concrete - It should be noted that adjacent existing concrete has cracking and damage - Additional cracking may be inherent to construction equipment &amp; operations required for the project site / Joint sealants / Salvaging removals / Electrical / Utilities</p> <p style="text-align: center;"><i>Thank You!</i></p>	<p><b>TOTAL</b>     \$     <b>22,500.00</b></p>

**PAYMENT TERMS:** Costs to be invoiced at end of month. Net 15 days.

**NOTE:** This estimate is good for 30 days. Please contact us for an updated price after that time. This is an estimate, not a contract. This estimate is for completing the job as described above. It is based on our evaluation and does not include material price increases or additional labor and materials which may be required due to unforeseen circumstances.

\_\_\_\_\_  
Bierman Contracting, Inc

\_\_\_\_\_  
Acceptance by Customer

\_\_\_\_\_  
Date

\_\_\_\_\_  
Date

THE PROFESSIONAL CHOICE



**B-D Construction, Inc.**  
2154 E. 32nd Ave.  
Columbus, NE 68601  
402.564.1225

**Estimate**

**Project:** CMS Planter Removal  
**Owner:** Columbus Public Schools  
2410 16th Street, Suite A  
Columbus, NE 68601  
Mike Grutsch  
**Scope:** Remove (3) Raised Planters at CMS

**Date:** 4.30.26  
**Estimator:** Bryan L. Kearney

Description of Work	Total Cost
<b>Remove (3) Planting Beds from CMS East Entrance</b>	\$25,650.00
<ul style="list-style-type: none"><li>- Protect existing sidewalks and concrete as best as possible with plywood</li><li>- Demo and Remove (3) raised brick wall planter beds</li><li>- Excavate and haul away existing landscaping, river rock and soil inside planter beds</li><li>- Remove soil dow to 9" below adjacent concrete surface</li><li>- Install 3" of crushed concrete sub base under new concrete- Approx. 1,850 SF Area</li><li>- Dowel into existing concrete around perimeter at 12" o.c. to connect new concrete to existing</li><li>- Pour approx. 1,850 SF of new concrete 6" thick where planter beds were removed</li><li>- Clean up and removal</li></ul>	

All materials, labor and equipment to complete the above scope of work is included

**Total Project Costs** **\$25,650.00**

*Payment Terms: Project costs to be invoiced at the end of each month or upon job completion. Net 15 Days Payment Expected*

*This estimate is valid for 30 days. Estimated should be checked for pricing updates after this time period. The estimate may be withdrawn by B-D Construction, Inc. if not accepted during this 30 day time period. This is an estimate based on our understanding of the project requirements. Changes may be required during construction should unforeseen circumstances dictate a change.*

**Acceptance:**  
Columbus Public Schools  
Mike Grutsch

**Date:**

**Submitted By:**  
B-D Construction, Inc.  
  
Bryan L. Kearney  
bryank@bdconstructioninc.com  
402.910.1306

**To:** Board of Education  
**From:** Leonard Kwapnioski  
**CC:** Dr. Kay  
**Date:** May 8, 2026  
**Re:** District Wireless/Network Upgrade(Erate)

It is my recommendation that the Board of Education consider approving **The District Wireless/Network Upgrade in the amount of \$462,759.33 from CDWG.**

Columbus Public Schools (CPS) received 5 competitive bids through the RFP process for this project. I have attached the bid from CDWG and the Funding Commitment Letter from USAC. Please note the following details regarding the scope of work:

- **Scope:** The quoted pricing covers the full replacement of the wireless network and the additional 8 network switches. All this is reviewed by USAC. CPS is responsible for the labor associated with the replacement/installation of devices.
- **Project Costs:** Payment/Reimbursement will come from USAC in the amount of \$362,591.26. The remaining balance in the amount of \$100,168.07 will come from the Technology Dept budget and depreciation.

If needed, I can provide a more detailed briefing during our meeting on **Monday, May 18th**. In the meantime, please feel free to reach out via email if you have any questions.

Thanks

Leonard



Thank you for choosing CDW. We have received your quote.

Hardware    Software    Services    IT Solutions    Brands    Research Hub

# QUOTE CONFIRMATION

### Pricing and Availability Notice

Due to ongoing supply chain challenges, some hardware manufacturers cannot guarantee product availability or pricing until the product is shipped. While we make every effort to honor quoted pricing, if a hardware manufacturer increases its price to CDW after a quote is issued or order is accepted, we may need to update your quoted price to reflect that change irrespective of any timeframes or validity periods set forth in the quote, including up to the date of shipment. In the event of a price adjustment, we will notify you prior to shipment. Any price adjustment would only occur if the hardware manufacturer increases its pricing to CDW.

### LEONARD KWAPNIOSKI,

Thank you for considering CDW•G for your technology needs. The details of your quote are below. **If you are an eProcurement or single sign on customer, please log into your system to access the CDW site.** You can search for your quote to retrieve and transfer back into your system for processing.

For all other customers, click below to convert your quote to an order.

**Convert Quote to Order**

QUOTE #	QUOTE DATE	QUOTE REFERENCE	CUSTOMER #	GRAND TOTAL
PSNM853	1/13/2026	ARUBA ERATE	4740329	\$462,759.33

### QUOTE DETAILS

ITEM	QTY	CDW#	UNIT PRICE	EXT. PRICE
<u>HPE Networking, Foundation Care Next Business Day Exchange Service - 3 years</u> Mfg. Part#: H34CLE Electronic distribution - NO MEDIA Contract: Sourcewell 121923-State of Nebraska (111216 04)	2	7160811	\$2,999.28	\$5,998.56
<u>HPE Networking, HP-991-MP10-B Campus Type B - mounting bracket</u> Mfg. Part#: Q9G69A UNSPSC: 31162313 Contract: Sourcewell 121923-State of Nebraska (111216 04)	42	5364140	\$76.92	\$3,230.64
<u>HPE Networking, Central Foundation - Subscription license (7 years) L1 only</u> Mfg. Part#: Q9Y61AAE Electronic distribution - NO MEDIA Contract: Sourcewell 121923-State of Nebraska Software (111216 04)	482	6635484	\$248.23	\$119,646.86
<u>HPE Networking, HP-991-MP10-E Campus Type E - mounting bracket</u> Mfg. Part#: R1C72A UNSPSC: 31162313 Contract: Sourcewell 121923-State of Nebraska (111216 04)	6	5450641	\$116.12	\$696.72

**QUOTE DETAILS (CONT.)**

<u>HPE Networking J740 - SFP28 transceiver module - expansion slot - SFP+ SFP2</u>	2	6989518	\$9,579.14	\$19,158.28
Mfg. Part#: R7H95A Contract: Sourcewell 121923-State of Nebraska (111216 O4)				
<u>HPE Networking - power supply - 550 Watt</u>	2	6989523	\$209.31	\$418.62
Mfg. Part#: R7J63A Contract: Sourcewell 121923-State of Nebraska (111216 O4)				
<u>HPE Aruba Central Foundation - subscription license-to-use (7 years) - 1.2W</u>	8	7583103	\$2,307.32	\$18,458.56
Mfg. Part#: R8L83AAE Electronic distribution - NO MEDIA Contract: Sourcewell 121923-State of Nebraska Software (111216 O4)				
<u>HPE Aruba Networking AP-675 (US) - wireless access point - Bluetooth, Wi-Fi</u>	8	7808703	\$956.61	\$7,652.88
Mfg. Part#: S0P50A Contract: Sourcewell 121923-State of Nebraska (111216 O4)				
<u>HPE Aruba User Experience Insight G6E Sensor - G-Series - wireless network</u>	10	7663466	\$352.17	\$3,521.70
Mfg. Part#: S0U51A Contract: Sourcewell 121923-State of Nebraska (111216 O4)				
<u>HPE Networking - power supply - 1600 Watt</u>	16	8120192	\$734.22	\$11,747.52
Mfg. Part#: S0U53A#ABA Contract: Sourcewell 121923-State of Nebraska (111216 O4)				
<u>HPE Networking Networking CX 5420 - switch - 6-slot - managed - rack-mounta</u>	8	8120206	\$2,467.43	\$19,739.44
Mfg. Part#: S0U59A Contract: Sourcewell 121923-State of Nebraska (111216 O4)				
<u>HPE Networking Networking CX 5420 24p 10M 100M 1G Class4 PoE Module - switc</u>	29	8120209	\$1,785.17	\$51,769.93
Mfg. Part#: S0U62A Contract: Sourcewell 121923-State of Nebraska (111216 O4)				
<u>HPE Networking Networking CX 5420 20p 10M 100M 1G Class4 PoE 2p SFP28 1G 10</u>	8	8147171	\$2,374.53	\$18,996.24
Mfg. Part#: S0U64A Contract: Sourcewell 121923-State of Nebraska (111216 O4)				
<u>HPE Networking Networking AP-ANT-311 - antenna - tri-band</u>	240	7647633	\$12.76	\$3,062.40
Mfg. Part#: S1F79A Contract: Sourcewell 121923-State of Nebraska (111216 O4)				
<u>HPE Networking networking AP-724 (US) - Campus - wireless access point - Wi</u>	60	7982213	\$550.16	\$33,009.60
Mfg. Part#: S1G33A Contract: Sourcewell 121923-State of Nebraska (111216 O4)				
<u>HPE Aruba Networking AP-725 (US) - Campus - wireless access point - Wi-Fi 2</u>	42	8484377	\$3,467.89	\$145,651.38
Mfg. Part#: S4A26A Contract: Sourcewell 121923-State of Nebraska (111216 O4)				

<b>SUBTOTAL</b>	\$462,759.33
<b>SHIPPING</b>	\$0.00
<b>SALES TAX</b>	\$0.00
<b>GRAND TOTAL</b>	<b>\$462,759.33</b>

PURCHASER BILLING INFO	DELIVER TO
<b>Billing Address:</b> COLUMBUS PUBLIC SCHOOLS DISTRICT TECHNO PO BOX 947 COLUMBUS, NE 68602-0947 <b>Phone:</b> (402) 563-7000 <b>Payment Terms:</b> ERATE QUOTES ONLY	<b>Shipping Address:</b> CPS DISTRICT TECHNOLOGY LEONARD KWAPNIOSKI 2508 27TH ST COLUMBUS, NE 68601-2541 <b>Shipping Method:</b> DROP SHIP-GROUND
	<b>Please remit payments to:</b>
	CDW Government 75 Remittance Drive Suite 1515 Chicago, IL 60675-1515



**Sales Contact Info**

**Dan Behnke** | (877) 325-6415 | [danbehn@cdwg.com](mailto:danbehn@cdwg.com)

**Need Help?**



My Account



Support



Call 800.800.4239

[About Us](#) | [Privacy Policy](#) | [Terms and Conditions](#)

This order is subject to CDW's [Terms and Conditions of Sales and Service Projects](http://www.cdw.com/content/terms-conditions/product-sales.aspx) at <http://www.cdw.com/content/terms-conditions/product-sales.aspx>

For more information, contact a CDW account manager.

© 2026 CDW•G LLC, 200 N. Milwaukee Avenue, Vernon Hills, IL 60061 | 800.808.4239

# Funding Commitment Decision Letter

## Funding Year 2026

**Contact Information:**

Leonard Kwapnioski  
COLUMBUS PUBLIC SCHOOL DIST  
2410 16th Street Suite A  
COLUMBUS, NE 68601  
[kwapnioskil@discoverers.org](mailto:kwapnioskil@discoverers.org)

**FCC Form 471:** 261013513**BEN:** 138477**Wave:** 1**Application Nickname:** CDWG\_471\_District\_Netw  
ork

## Totals

	<b>Total Committed</b>	<b>\$362,591.26</b>
--	------------------------	---------------------

## What is in this letter?

Thank you for submitting your application for Funding Year 2026 Schools and Libraries Program (E-rate) funding. Attached to this letter, you will find the funding statuses for the FCC Form(s) 471, Services Ordered and Certification Form, that you submitted and referenced above.

The Universal Service Administrative Company (USAC) is sending this information to both the associated applicant(s) and the service provider(s) so that you can work together to complete the funding process.

## Next Steps

1. Work with your service provider(s) to determine if your bills will be discounted or if you will request reimbursement from USAC after paying the full cost for the services you receive.
2. Review the [Children's Internet Protection Act \(CIPA\)](#) requirements and file the [FCC Form 486 \(Service Confirmation and CIPA Certification Form\)](#). **The deadline to submit this form is 120 days from the date of this letter or from the service start date (whichever is later).**
3. Invoice USAC

- **If you (the applicant) are invoicing USAC:** You must pay your service provider(s) the full cost for the services you receive and file the [FCC Form 472](#), the Billed Entity Applicant Reimbursement (BEAR) Form, to invoice USAC for reimbursement of the discounted amount.
- **If your service provider(s) is invoicing USAC:** The service provider(s) must provide services, bill the applicant for the non-discounted share, and file the [FCC Form 474](#), the Service Provider Invoice (SPI) form, to invoice USAC for reimbursement for the discounted portion of costs. Every funding year, service providers must file an [FCC Form 473](#), the Service Provider Annual Certification Form, to be able to submit invoices and to receive disbursements.
- **To receive an invoice deadline extension, the applicant or service provider must request an extension on or before the last date to invoice. If you anticipate, for any reason, that invoices cannot be filed on time, USAC will grant a one-time, 120-day invoice deadline extension if timely requested.**

## How to Appeal or Request a Waiver of a Decision

You can appeal or request a waiver of a decision in this letter **within 60 calendar days** of the date of this letter. Failure to meet this deadline will result in an automatic dismissal of your appeal or waiver request.

**Note:** The Federal Communications Commission (FCC) will not accept appeals of USAC decisions that have not first been appealed to USAC. However, if you are seeking a waiver of E-rate program rules, you must submit your request to the FCC and not to USAC. USAC is not able to waive the E-rate program rules.

- **To submit your appeal to USAC,** visit the Appeals section in the [E-rate Productivity Center \(EPC\)](#) and provide the required information. USAC will reply to your appeal submissions to confirm receipt. Visit USAC's [website](#) for additional information on submitting an appeal to USAC, including step-by-step instructions.
- **To request a waiver of the FCC's rules,** please submit it to the FCC in proceeding number CC Docket No. 02-6 using the [Electronic Comment Filing System \(ECFS\)](#). Include your contact information, a statement that your filing is a waiver request, identifying information, the FCC rule(s) for which you are seeking a waiver, a full description of the relevant facts that you believe support your waiver request and any related relief, and any supporting documentation.

For appeals to USAC or to the FCC, be sure to keep a copy of your entire appeal, including any correspondence and documentation, and provide a copy to the affected service provider(s).

## **Obligation to Pay Non-Discount Portion**

Applicants are required to pay the non-discount portion of the cost of the eligible products and/or services to their service providers. Service providers are required to bill applicants for the non-discount portion of costs for the eligible products and/or services. The FCC stated that requiring applicants to pay the non-discounted share of costs ensures efficiency and accountability in the program. If using the BEAR invoicing method, the applicant must pay the service provider in full (the non-discount plus discount portion) **before** seeking reimbursement from USAC. If using the SPI invoicing method, the service provider must first bill the applicant **before** invoicing USAC.

## **Notice on Rules and Funds Availability**

The applicants' receipt of funding commitments is contingent on their compliance with all statutory, regulatory, and procedural requirements of the Schools and Libraries Program and the FCC's rules. Applicants who have received funding commitments continue to be subject to audits and other reviews that USAC and/or the FCC may undertake to assure that committed funds are being used in accordance with such requirements. USAC may be required to reduce or cancel funding commitments that were not issued in accordance with such requirements, whether due to action or inaction of USAC, the applicant, or the service provider. USAC, and other appropriate authorities (including but not limited to the FCC), may pursue enforcement actions and other means of recourse to collect improperly disbursed funds.

# Funding Commitment Decision Overview

## Funding Year 2026

### Application Comments for FCC Form 471: #261013513

The applicant did not submit any RAL corrections.

### Funding Commitment Decision Overview

<b>Funding Request Number (FRN)</b>	<b>Service Provider Name</b>	<b>Amount Requested</b>	<b>Amount Committed</b>	<b>Status</b>
2699016286	CDW Government LLC	\$370,207.46	\$362,591.26	Funded

<b>FRN</b> 2699016286	<b>Service Type</b> Internal Connections	<b>Status</b> Funded
--------------------------	---	-------------------------



<b>Dollars Committed</b>			
<b>Monthly Cost</b>		<b>One-time Cost</b>	
Months of Service	12		
Total Eligible Recurring Charges	\$0.00	Total Eligible One Time Charges	\$453,239.07
Total Pre-discount Charges		\$453,239.07	
<b>Discount Rate</b>		<b>80.00%</b>	
<b>Committed Amount</b>		<b>\$362,591.26</b>	

<b>Dates</b>	
<b>Service Start Date</b>	7/1/2026
<b>Contract Expiration Date</b>	6/30/2027
Contract Award Date	2/17/2026
Service Delivery Deadline	9/30/2027
Expiration Date (All Extensions)	

<b>Service Provider and Contract Information</b>	
Service Provider	CDW Government LLC
SPIN (498ID)	143005588
Contract Number	
Account Number	
Establishing FCC Form 470	260012980
Invoicing Method	Service Provider - FCC Form 474 (SPI Form)

<b>Consultant Information</b>	
Consultant Name	
Consultant's Employer	ESU 7 E-Rate Consulting
CRN	17023320

**Funding Commitment Decision Comments**

MR1: The Type of Internal Connection for FRN Line Item 2699016286.005 was modified from Miscellaneous to Wireless Data Distribution to agree with the applicant documentation.  MR2: The Product Type for FRN Line Item 2699016286.005 was modified from Installation, Activation, & Initial Configuration to Access Point to agree with the applicant documentation.  MR3: The Type of Internal Connection for FRN Line Item 2699016286.006 was modified from Miscellaneous to Wireless Data Distribution to agree with the

applicant documentation. **MR4:** The Product Type for FRN Line Item 2699016286.006 was modified from Installation, Activation, & Initial Configuration to Access Point to agree with the applicant documentation.

**MR5:** The Type of Internal Connection for FRN Line Item 2699016286.007 was modified from Wireless Data Distribution to Module to agree with the applicant documentation.

**MR6:** The Product Type for FRN Line Item 2699016286.007 was modified from Wireless Controller to Module to agree with the applicant documentation.

**MR7:** The Type of Internal Connection for FRN Line Item 2699016286.008 was modified from Wireless Data Distribution to Module to agree with the applicant documentation.

**MR8:** The Product Type for FRN Line Item 2699016286.008 was modified from Wireless Controller to Module to agree with the applicant documentation.

**MR9:** The Type of Internal Connection for FRN Line Item 2699016286.012 was modified from Data Distribution to Module to agree with the applicant documentation.

**MR10:** The Product Type for FRN Line Item 2699016286.012 was modified from Switch to Module to agree with the applicant documentation.

**MR11:** The Type of Internal Connection for FRN Line Item 2699016286.013 was modified from Data Distribution to Module to agree with the applicant documentation.

**MR12:** The Product Type for FRN Line Item 2699016286.013 was modified from Switch to Module to agree with the applicant documentation.

**MR13:** The Type of Internal Connection for FRN Line Item 2699016286.014 was modified from Data Distribution to Module to agree with the applicant documentation.

**MR14:** The Product Type for FRN Line Item 2699016286.014 was modified from Switch to Module to agree with the applicant documentation.

**MR15:** The Type of Internal Connection for FRN Line Item 2699016286.015 was modified from Software to License to agree with the applicant documentation.

**MR16:** The Product Type for FRN Line Item 2699016286.015 was modified from Operating System Software of Eligible Equipment to License to agree with the applicant documentation.

**MR17:** The Type of Internal Connection for FRN Line Item 2699016286.016 was modified from Software to License to agree with the applicant documentation.

**MR18:** The Product Type for FRN Line Item 2699016286.016 was modified from Operating System Software of Eligible Equipment to License to agree with the applicant documentation.

**MR19:** The amount of the funding request was changed from \$462,759.33 to \$456,760.77 to remove the ineligible product(s) or service(s): Aruba NBD Replacement only for 9240 Gateway (H34CLE).

**MR20:** The funding request was modified from \$456,760.77 to \$453,239.07 to remove the Managed Internal Broadband Services that was not posted on the FCC Form 470.







Columbus Public Schools

Date:

4/28/26

### School Fundraising Application

Please submit this application to the building principal at least two weeks in advance of the proposed date of your money-raising project. Please read the eight guides on page two. They will help you in answering the questions below.

School: [Select One] Columbus High School Band

Fund Raising Company (if applicable): Fundraising U

(School/Group Name), submits the following plans for its money-earning project, and requests permission to carry them out.

## Selling Discount Cards

What is your school/group's money-earning plan?

Approximately how much does your school/group expect to earn from this project?

\$6000

How will this money be used?

Funds are used for band activity expenses and trips

What are the proposed dates?

7/27/2026-8/31/2026

Is this a recurring activity?

Yes  No

(If you selected yes, please specify the dates on which the activity will occur during the next twelve months.)

Are you selling tickets or a product?  Tickets  Product  Neither

(If you selected product, please specify the product that you are selling.)

Will members be identified by t-shirts, etc. while carrying out this project?  Yes  No

Have you checked with other schools to avoid any overlapping while working?  Yes  No

Is your product/service in direct conflict with that offered by local merchants?  Yes  No

Are any contracts to be signed?  Yes  No If yes, by whom?

Peabody

Has your school/group devised a budget plan to expend earnings?  Yes  No

Does the building principal give full approval for this plan?  Yes  No

Principal's Signature [Signature]

Date 5/7/26

(for district use only)

Approved by \_\_\_\_\_ Date \_\_\_\_\_

Approved subject to the following conditions \_\_\_\_\_

\_\_\_\_\_

\_\_\_\_\_



Columbus Public Schools

Date: 4/28/26

### School Fundraising Application

Please submit this application to the building principal at least two weeks in advance of the proposed date of your money-raising project. Please read the eight guides on page two. They will help you in answering the questions below.

School: [Select One] Columbus High School Band/Theater

Fund Raising Company (if applicable): Bellino Fireworks

(School/Group Name), submits the following plans for its money-earning project, and requests permission to carry them out.

What is your school/group's money-earning plan? Selling Fireworks

Approximately how much does your school/group expect to earn from this project?

\$10000

How will this money be used?

Funds are used for band activity expenses and trips

What are the proposed dates?

6/28/2026-7/4/2026

Is this a recurring activity?

Yes  No

(If you selected yes, please specify the dates on which the activity will occur during the next twelve months.)

Are you selling tickets or a product?  Tickets  Product  Neither

(If you selected product, please specify the product that you are selling.)

Will members be identified by t-shirts, etc. while carrying out this project?  Yes  No

Have you checked with other schools to avoid any overlapping while working?  Yes  No

Is your product/service in direct conflict with that offered by local merchants?  Yes  No

Are any contracts to be signed?  Yes  No If yes, by whom? Peabody

Has your school/group devised a budget plan to expend earnings?  Yes  No

Does the building principal give full approval for this plan?  Yes  No

Principal's Signature [Signature]

Date 6/7/26

(for district use only)

Approved by \_\_\_\_\_ Date \_\_\_\_\_

Approved subject to the following conditions \_\_\_\_\_

\_\_\_\_\_

## Discoverer Bands Trip Request

**Name** Jeff Peabody

**Email** peabodyj@discoverers.org

**Which Ensemble?**

**Departure Date of Proposed Travel** Monday, July 6, 2026

**Return Date of Proposed Travel** Friday, July 10, 2026

**Desired Trip Location** Fort Collins Colorado

**Purpose and Rationale for the Trip**  
Drum Major Training Camp

**Approximate Cost**  
\$900 per student

**Are you requesting funds from the District?** No

**A brief description of the travel details.**

Mr. McGill and the 2 drum majors will depart on Monday 7/6 to go to the George Parks Drum Major Academy at Colorado State University.

This is an annual trip for training of our Marching Band Drum Majors.

# COLUMBUS PUBLIC SCHOOLS

## Board Policy

### **Student Activism – Protests, Walkouts, and Demonstrations**

#### **Policy 504.07R1**

#### **I. Purpose**

The Board of Education recognizes that students possess constitutional rights to freedom of speech and expression. The Board also acknowledges its fundamental responsibility to maintain a safe, orderly, and effective educational environment for all students. This policy establishes guidelines for student activism activities, including protests, walkouts, and demonstrations, that balance students' rights with the district's obligation to provide uninterrupted instruction and ensure student safety.

#### **II. Legal Framework**

This policy is grounded in established constitutional law regarding student speech rights in public schools:

**A. Tinker v. Des Moines Independent Community School District (1969):**

Students do not "shed their constitutional rights to freedom of speech or expression at the schoolhouse gate." However, schools may regulate student speech that causes a "material and substantial disruption" to the educational process or that invades the rights of others.

**B. Bethel School District v. Fraser (1986):** Schools may prohibit student speech that is vulgar, lewd, or plainly offensive.

**C. Compulsory Attendance Laws:** Nebraska state law requires students to attend school. A walkout or leaving school grounds without permission constitutes an unexcused absence regardless of the purpose.

#### **III. Policy Statement**

School district educators have the responsibility to the community to maintain an effectual educational environment when confronted with disruptive activities. Therefore, the following provisions shall apply during the school day and at school activities:

##### **A. Attendance and Excused Absences**

Students shall not be excused from school, except by prior parent conference or permission with the principal, to attend demonstrations or other rallies held during school time. Any student who leaves school property, a school building, or the student's assigned classroom without prior authorization will be marked as having an unexcused absence. Student-led events are not approved or sponsored by the school, and student attendance records will reflect participation accordingly.

##### **B. Prohibition of Disruptive Activities**

Disruptive protests, walkouts, and demonstrations shall be forbidden in the schools. Activities that substantially disrupt the educational environment, interfere with classroom instruction, impede the safe movement of students and staff, or violate the rights of others are prohibited. Examples of prohibited disruptive conduct include, but are not limited to: blocking hallways, stairwells, or entrances; creating excessive noise that interferes with instruction; occupying administrative offices; and organizing walkouts during instructional time. In addition to unexcused absences, students who engage in disruptive activities may face disciplinary measures consistent with the Student Code of Conduct.

### **C. Use of School Resources**

School resources, including but not limited to poster material, copy machines, computers, school email systems, school-issued devices, bulletin boards, and public address systems, may not be used to create, distribute, or promote materials for protests, walkouts, or demonstrations.

### **D. Staff Neutrality and Responsibilities**

Teachers and staff members shall not encourage or discourage student participation in protests, walkouts, or demonstrations. Staff members shall maintain neutrality regarding the subject matter of any student activism activity. Educators may provide objective, factual information about civic engagement and constitutional rights as part of the educational curriculum, but shall not advocate for or against specific protest activities.

Staff responsibilities during student-organized events:

- Inform student of school policies related to protests.
- If students approach staff with questions, inform them that student-led events are not approved or sponsored by the school.
- Classes will remain in session during any student-organized event. Students who remain in school will report to their regularly scheduled classes.
- Staff may not participate or engage in any protests, walkouts, or demonstrations that occur on school grounds during the school day, but may be required (by administration) to provide supervision to ensure the safety of students.
- Staff shall apply disciplinary action for misbehavior during events as they would for classroom behavior and before/after school behaviors. Students must be peaceful and respectful at all times.

### **E. Designated Areas and Student Accountability**

If students choose to engage in expressive activity on school grounds, they may be directed to a specific designated location on campus that minimizes disruption to the educational environment. Failure to follow administrative direction regarding location will result in removal and appropriate disciplinary action. Student accountability procedures shall be maintained at all times. The district can only monitor and supervise students who remain on school grounds. Once the directive to return to class has been given students failing to comply will be disciplined in accordance with school policy on student conduct and truancy.

## F. Protected Expression

Students retain their right to engage in non-disruptive forms of expression that do not interfere with the educational environment. Protected forms of expression may include: wearing buttons, armbands, or clothing with political messages (subject to dress code provisions); silent, passive expression during non-instructional time; distribution of literature during non-instructional time in designated areas; and respectful dialogue with peers and staff.

## IV. Consequences

- A. Students who leave school without authorization to participate in a demonstration will be marked with an unexcused absence. Disciplinary minutes will be assigned for unexcused absences consistent with current policy. If students are not present for class, they shall be counted absent unless they return to class, in which case it shall be recorded as a tardy.
- B. **Activity Eligibility:** According to CPS policy, students participating in school-sanctioned activities must be present on the day of the contest, performance, or other activity, students must be in attendance for their first class and remain in attendance for the remainder of the day. A student who is not in attendance the full day may be ineligible for the contest, performance, practice, or activity.
- C. Disciplinary action for violations of this policy shall be administered consistent with the Student Code of Conduct and applicable law.
- D. **Viewpoint Neutrality Requirement:** Disciplinary measures must be applied consistently regardless of the political viewpoint or message of the student expression. Students may not be punished more severely for engaging in political protest than for other attendance or conduct violations of a similar nature.
- E. Consequences may include, but are not limited to: verbal warning, parent notification, detention, in-school suspension, or out-of-school suspension, depending on the severity and frequency of the violation.

## V. Safety and Emergency Procedures

- F. Building administrators shall develop procedures for student accountability during protest activities.
- A. If students leave campus, the school shall notify parents/guardians as soon as practicable. The District has no ability to supervise or monitor students who leave campus. As a result, students who leave campus do so at their own risk and building attendance policies will be applied.
- G. Available administrators and designated staff shall supervise any activity on campus and maintain the safety of students. School administrators and, when appropriate, school resource officers shall remain with students engaged in protest activities on or near school grounds to ensure student safety.
- H. **Campus Security:** In the interest of student safety, school campuses may be closed during any student-organized event, and **visitors will not be allowed**

**onto the campus to join or otherwise interact with students during the event.** This will be enforced to the extent determined necessary for student safety and the avoidance of undue disruption.

- I. Once the directive to return to class has been given students failing to comply will be disciplined in accordance with school policy on student conduct and truancy.

## **VI. Media and External Communications**

- J. When campus is closed to visitors during a student-organized event, outside news media will not be allowed inside school buildings during the event and should remain in public areas off school property.
- K. All news media requesting information shall be directed to the designated district spokesperson or the Superintendent's Office. Staff members shall not provide statements to media without authorization.

## **VII. Proactive Communication**

When administrators become aware of planned protest activities, they are encouraged to meet with student organizers in advance to discuss: appropriate time, place, and manner for expression; designated areas for demonstrations; safety protocols; and potential consequences for policy violations. Such meetings are intended to ensure student safety and minimize disruption while respecting students' rights to express their views.

### **A. Parent/Guardian Notification**

If possible, based on the priority to ensure student safety first, parents of students without permission to attend the event will be notified. Based on the size of the event, an all-parent communication may be sent out notifying parents that their child may be involved and the extent of the activity.

Communication protocols shall be followed to inform parents and the community of any significant disruption to the school day.

## **VIII. Alternative Civic Engagement Opportunities**

The district encourages students to explore constructive avenues for civic engagement that do not disrupt the educational environment. While the district cannot support actions that interfere with the instructional day, it recognizes students' desire to make a difference. These alternatives may include: participating in student government; attending school board meetings during the public comment period; writing letters to elected officials; organizing events before or after school hours; and engaging in classroom discussions on civic issues as part of the curriculum.

## **IX. Legal References**

U.S. Constitution, First Amendment

*Tinker v. Des Moines Independent Community School District*, 393 U.S. 503 (1969)

*Bethel School District No. 403 v. Fraser*, 478 U.S. 675 (1986)

*Hazelwood School District v. Kuhlmeier*, 484 U.S. 260 (1988)

Nebraska Compulsory Attendance Laws, Neb. Rev. Stat. §79-201

**X. Cross References**

- 504.07 Freedom of Expression
  - 504.03 Student Code of Conduct
  - 503.01 Student Compulsory Attendance
  - 503.03 Student Absences
  - 503.05 Student Release During School Hours
  - 504.05 Student Dress Code Policy
  - 508.05 Emergency Operations Plan
  - 506 Student Activities
  - 604.10 Academic Freedom
  - 1005.10 Distribution or Posting of Materials
- 

**Adopted:** \_\_\_\_\_

**Revised:** \_\_\_\_\_

## FREEDOM OF EXPRESSION

Student expression, other than student expression in student-produced official school publications, made on the school district premises or under the jurisdiction of the school district or as part of a school-sponsored activity may be attributed to the school district; therefore, student expression must be responsible. Student expression must be appropriate to assure that the students learn and meet the goals of the school activity and that the potential audience is not exposed to material that may be harmful or inappropriate for their level of maturity.

Students will be allowed to express their viewpoints and opinions as long as the expression is responsible. The expression shall not, in the judgment of the administration, encourage the breaking of laws, defamation of persons, be obscene or indecent, or cause a material and substantial disruption to the educational program. The administration, when making this judgment, shall consider whether the activity in which the expression was made is school-sponsored and whether review or prohibition of the students' speech furthers an educational purpose. Further, the expression must be done in a reasonable time, place, and manner that is not disruptive to the orderly and efficient operation of the school district.

Students who violate this policy may be subject to disciplinary measures. Employees shall be responsible for insuring students' expression is in keeping with this policy. It shall be the responsibility of the superintendent to develop administrative regulations regarding this policy.

Legal Reference: U.S. Const. amend. I.  
Hazelwood School District v. Kuhlmeier, 484 U.S. 260 (1988).  
Bethel School District v. Fraser, 478 U.S. 675 (1986).  
Tinker v. Des Moines Ind. Comm. Sch. Dist., 393 U.S. 503 (1969).  
Bystrom v. Fridley High School, 822 F.2d 747 (8th Cir. 1987).

Cross Reference: 504 Student Rights and Responsibilities  
506 Student Activities  
604.10 Academic Freedom  
1005.10 Distribution or Posting of Materials

Policy  
Adopted: 9/11/06

COLUMBUS PUBLIC SCHOOLS  
Columbus, Nebraska

## Recommended Changes

# Columbus Public Schools

## In-District Transfer Guide for Parents

### What is an In-District Transfer?

An in-district transfer allows your student to attend a Columbus Public Elementary School other than the school assigned to your home address. Transfers are approved based on a continuum of reasons and are not guaranteed. If approved, transportation must be provided by parents or guardians.

### Which Form Do You Need?

Choose the appropriate form based on your situation:

FORM 502.09R1	FORM 502.09R2
<p><b>General Transfers</b> Use for any transfer request not related to a move within the district.</p> <p><b>Application Timeline:</b></p> <ul style="list-style-type: none"><li>• Must be submitted before May 1 for the upcoming school year.</li><li>• On May 1, after, or during the school year requests are processed at the end of each quarter.</li></ul>	<p><b>Moving Within District</b> Use when you move to a new address that changes your school assignment.</p> <p><b>Available:</b></p> <ul style="list-style-type: none"><li>• Year-round, processed at end of each quarter.</li></ul>

### Key Criteria, in order, for Approval

1. Student is not currently suspended or expelled from their current school building
2. Student is permitted no more than one (1) in-district general transfer while in grades K-4
3. Requested building has space based on capacity stated in board policy 502.05E1
4. If the student receives any support services like Title I, special education/IEP, Section 504, or ESL is there an availability to meet the needs of the student
5. If the student has not been in regular attendance at their current school and is part of the diversion or support program will this transfer create an additional barrier for attendance

An **approved transfer** is in effect for the remainder of the school year and for remaining years a student is in grades K-4 unless the student changes domiciles/home address.

### Need Help?

Contact your child's current school principal or the Columbus Public Schools district office for assistance with the transfer process or to obtain the appropriate form.

### Nondiscrimination

*The Board, the superintendent, other administrators and teachers shall not make any distinction on account of race, sex, ethnic group, religion or disability of any student who may be in attendance or who seeks admission to any school maintained by the district in the determination or recommendation of action under this policy.*

# COLUMBUS PUBLIC SCHOOLS REQUEST FOR STUDENT-WITHIN-DISTRICT TRANSFER DURING THE CURRENT SCHOOL YEAR

Parents or guardians who want their child to attend a different school within the district other than their address-assigned school, or situations where they have moved to a new attendance area, must submit a formal request at least two weeks before the end of the quarter. Requests will be reviewed at the end of each quarter, and approved transfers will take effect at the beginning of each quarter.

Date: \_\_\_\_\_ Is this transfer request due to a move within the district:  Yes  No

Parent/Guardian Name: \_\_\_\_\_ Phone Number: \_\_\_\_\_

Student Name: \_\_\_\_\_ Date of Birth: \_\_\_\_\_ Grade: \_\_\_\_\_

Current Address: \_\_\_\_\_ Previous Address: \_\_\_\_\_

Assigned School: \_\_\_\_\_ Requested School: \_\_\_\_\_

School Currently Attending (if different than assigned school): \_\_\_\_\_

Please provide a detailed reason why you are making this request:

---

---

---

List all other siblings living in primary household that are under the age of 22 years.

Last Name	First Name	DOB	Gender	Grade

*I understand that transportation is to be provided by parents or legal guardians.*

Parent's/Guardian's Signature: \_\_\_\_\_

For office Use Only:

District Representative's Signature: \_\_\_\_\_ Date: \_\_\_\_\_

Approved  Denied

~~ALTERNATIVE SCHOOL ADMISSIONS~~  
IN DISTRICT TRANSFER

### ~~Open-Enrollment and Transfers~~

Students within **their** designated **elementary** attendance areas shall have priority in registering in that school. This shall also apply to home-schooled students desiring to take classes on a part-time basis. Students may apply for ~~alternative~~ enrollment in a school outside their attendance area and such applications shall be approved if there is space available in the requested school and the application has been submitted on or before ~~(August 1)~~ **May 1<sup>st</sup>** in accordance with the regulations accompanying this policy.

Parents and/or students who desire a change of school after ~~August 1~~ **May 1<sup>st</sup>** submit a letter together with the required form requesting a transfer. The request shall be reviewed and acted upon in accordance with the regulations accompanying this policy.

Notwithstanding the provisions of this policy, a student may be assigned outside the attendance area by mutual agreement of the principals in the special interest of the student and/or school.

~~Students granted permission to attend a school other than the school in their assigned attendance area shall have the same curricular and extracurricular status as all other students attending the school, limited only by rules of the Nebraska School Activities Association.~~

Approved applications for ~~alternative~~ enrollment shall be valid for attendance at that school throughout the grades served by the school as capacity allows.

Transfer students attending a school outside their attendance area shall be granted admission on a year-to-year basis. In the event the population of the attendance area increases to fill the building with attendance areas residents, transfer students may be asked to enroll in another school. **A student is permitted no more than one (1) in-district general education transfer while in grades K-4 unless a change of domicile occurs.**

The Board reserves the right to rescind and/or amend any or all ~~alternative elementary~~ enrollments, **boundaries**, or transfers if in its opinion overcrowding of facilities, **programs, services**, or other undesirable conditions develop.

### **Transportation**

Transportation for students granted permission to attend school outside their attendance area must be furnished by their parents unless it is determined that transportation is necessary for the district to comply with state and federal law requirements for homeless or disabled students.

## **Nondiscrimination**

The Board, the superintendent, other administrators and teachers shall not make any distinction on account of race, sex, ethnic group, religion or disability of any student who may be in attendance or who seeks admission to any school maintained by the district in the determination or recommendation of action under this policy.

## **Special education students**

Requests from the parents of special education students for ~~open~~-enrollment or transfer to another school or program **in or out of the school district** shall be considered in accordance with applicable state and federal laws. The student's current Individual Education Plan (IEP) shall be used to determine if the requested school or program can meet the student's needs.

Legal Reference:                      Neb. Statute 79-235

Cross Reference:                      502    Student Admissions  
    601    Goals and Objectives  
    605    Alternative Programs

Policy  
Adopted: 9/11/06  
Amended: 5/18/26

COLUMBUS PUBLIC SCHOOLS

Columbus, Nebraska



## **CERTIFICATED EMPLOYEE CONTRACT RELEASE**

Pursuant to Policy 406.04 and Neb. Rev. Stat. §79-829, certificated employee contracts are continuing in nature. No certificated employee shall be required to signify acceptance of employment for the ensuing school year prior to March 15.

Mid-year resignations and resignations given late in the spring for the following school year may substantially disrupt staffing, scheduling, continuity of instruction, budgeting, and the District's ability to recruit and retain qualified personnel. The Board or administration may issue a written request for certificated employees to signify acceptance of employment for the following school year due on or after March 15 of each school year. Certificated employees shall respond within the time designated in the request. Failure of a certificated employee to signify acceptance of employment within the designated time may be considered by the Board as grounds for nonrenewal, cancellation, or termination of the employee's contract, subject to the procedures set forth in Neb. Rev. Stat. §§79-824 to 79-842. Nothing in this policy shall be construed to limit the Board's authority to make assignments, reassignments, reductions in force, or other employment decisions authorized by law.

In accordance with Neb. Rev. Stat. §79-828, any probationary certificated employee whose contract the Board intends not to renew shall be notified in writing on or before April 15. The employee shall have the right to a hearing before the Board of Education as provided by statute.

A certificated employee who wishes to be released from his or her contract for the following school year may submit a written request to the Superintendent or his or her designee. The Superintendent or his or her designee shall have the sole responsibility for determining the criteria used to define a suitable replacement for each position.

All requests for contract release shall be reviewed and decided on a case-by-case basis. The Board may, but shall not be required to, reconsider a denial of a request for contract release upon written request by the certificated employee

If, in the opinion of the certificated employee, unusual circumstances exist, the certificated employee may appeal to the Board to reconsider a denial of the request for contract release.

The Superintendent or his or her designee is authorized to file a complaint with the Nebraska Department of Education and/or the Nebraska Professional Practices Commission against a certificated employee who leaves without proper release from the Board.

The Board of Education reserves the right to seek damages against any certificated employee as a result of breach of contract.

### **Legal Reference:**

Neb. Rev. Stat. §79-828 (Probationary Certificated Employees; Nonrenewal; Notice)

Neb. Rev. Stat. §79-829 (Permanent Certificated Employees; Contract; Acceptance of Employment)

**Cross Reference:**

406.03 Certificated Employee Individual Contracts

406.04 Continuing Contracts

408.03 Certificated Employee Retirement

Adopted: \_\_\_\_\_

Revised: \_\_\_\_\_

DRAFT

# COLUMBUS PUBLIC SCHOOLS

Columbus, Nebraska

**BOARD POLICY**  
Policy Code: 402.22

Category: Personnel  
Adopted: [Date]

## VIDEO SURVEILLANCE IN THE WORKPLACE

### I. PURPOSE

The Board of Education recognizes its responsibility to maintain a safe and secure environment for students, staff, and visitors while respecting the reasonable privacy expectations of employees. This policy establishes guidelines for the use of video surveillance systems on district property to enhance security, deter criminal activity, protect district assets, and assist in investigations of policy violations or unlawful conduct.

### II. LEGAL FRAMEWORK

This policy is adopted in compliance with applicable federal and state laws, including but not limited to:

- The Electronic Communications Privacy Act of 1986 (18 U.S.C. §§ 2510-2522)
- Nebraska Revised Statutes §§ 86-283 through 86-295 (Interception of Communications)
- Nebraska Revised Statute § 28-311.08 (Unlawful Intrusion; Recording in Places of Solitude)
- Nebraska Workplace Privacy Act (Neb. Rev. Stat. §§ 48-3501 to 48-3511)
- National Labor Relations Act, Section 7 (29 U.S.C. § 157)

### III. POLICY STATEMENT

The district may utilize video surveillance systems for legitimate safety, security, and operational purposes. Video surveillance shall be conducted in a manner that balances the district's security interests with employees' reasonable expectations of privacy. The district shall not use video surveillance for the purpose of monitoring employee work performance except where there is a documented, specific concern regarding potential misconduct, safety violations, or policy violations.

## **IV. AUTHORIZED SURVEILLANCE LOCATIONS**

Video surveillance may be conducted in areas where employees and others do not have a reasonable expectation of privacy, including but not limited to:

- Building entrances, exits, and exterior doors
- Hallways and corridors
- Parking lots and exterior grounds
- Gymnasiums, cafeterias, and common areas
- Libraries and media centers
- Loading docks and receiving areas
- Storage and supply rooms
- School buses and district vehicles (interior and exterior)
- Classrooms (for security purposes, with appropriate notice)

## **V. PROHIBITED SURVEILLANCE LOCATIONS**

Video surveillance is strictly prohibited in any location where employees, students, or visitors have a reasonable expectation of privacy, including:

- Restrooms and toilet facilities
- Locker rooms, shower areas, and changing rooms
- Private offices with closed doors (unless consented to or pursuant to an authorized investigation)
- Lactation rooms or nursing areas
- Health offices or areas where medical treatment is provided
- Any area designated for union activities or collective bargaining discussions

## **VI. AUDIO RECORDING**

Nebraska is a one-party consent state for audio recording. However, to minimize legal risk and maintain employee trust, audio recording capabilities on surveillance systems shall be disabled unless: (a) written notice is conspicuously posted in the area indicating audio recording is in use; (b) there is a specific, documented security need for audio recording approved by the Superintendent; and (c) the recording is not conducted in areas where employees have a reasonable expectation of private conversation. The district shall not conduct covert audio recording of employee conversations.

## VII. NOTICE REQUIREMENTS

The district shall provide notice of video surveillance through the following means:

- A. **Written Policy Notice:** All employees shall receive written notice of this policy upon hire and whenever the policy is materially amended. Employees shall acknowledge receipt of the notice in writing.
- B. **Signage:** Conspicuous signs shall be posted at building entrances and other appropriate locations indicating that video surveillance is in use on district premises.
- C. **Employee Handbook:** This policy shall be included in the employee handbook and accessible to all staff.

## VIII. ACCESS AND SECURITY OF RECORDINGS

Access to video surveillance recordings and monitoring equipment shall be strictly limited to authorized personnel. The Superintendent shall designate individuals authorized to access surveillance systems and recordings. Unauthorized access, duplication, or distribution of recordings is prohibited and may result in disciplinary action.

## IX. RETENTION OF RECORDINGS

Video recordings shall be retained in accordance with the district's records retention schedule and applicable law. Routine recordings not involved in an incident, investigation, or legal matter shall be retained for a minimum of thirty (30) days and may be overwritten thereafter. Recordings that are part of a disciplinary matter, legal proceeding, or investigation shall be preserved until the matter is fully resolved and any applicable appeal period has expired.

## X. PERMISSIBLE USE OF RECORDINGS

Video surveillance recordings may be used for the following purposes:

- Investigation of criminal activity, safety incidents, or security breaches
- Investigation of alleged violations of district policy, rules, or regulations
- Assistance to law enforcement agencies pursuant to lawful requests
- Documentation of safety drills and emergency procedures
- Verification of incidents for insurance, liability, or litigation purposes

## **XI. PROHIBITED USES**

Video surveillance shall not be used for:

- Routine monitoring of employee work performance or productivity
- Harassment, intimidation, or targeting of specific individuals
- Monitoring of protected concerted activity under the National Labor Relations Act
- Any purpose unrelated to legitimate security, safety, or investigative needs
- Personal viewing or entertainment

## **XII. COMPLAINTS AND CONCERNS**

Employees who believe that video surveillance is being conducted in violation of this policy or applicable law may report their concerns to the Director of Human Resources or the Superintendent. Complaints will be investigated promptly, and corrective action will be taken as appropriate. The district prohibits retaliation against any employee who, in good faith, reports a concern regarding video surveillance practices.

## **XIII. ADMINISTRATION**

The Superintendent is authorized to develop administrative regulations to implement this policy, including procedures for requesting access to recordings, protocols for investigations involving surveillance footage, and standards for the installation and maintenance of surveillance equipment.

## **XIV. POLICY REVIEW**

This policy shall be reviewed periodically to ensure compliance with applicable law and alignment with best practices in workplace privacy and security.

### **Legal References:**

Electronic Communications Privacy Act, 18 U.S.C. §§ 2510-2522

National Labor Relations Act, 29 U.S.C. § 157

Neb. Rev. Stat. §§ 86-283 to 86-295

Neb. Rev. Stat. § 28-311.08

Neb. Rev. Stat. §§ 48-3501 to 48-3511 (Workplace Privacy Act)

*Cross References: Policy 402.01 (Equal Employment Opportunity); Policy 405.00 (Employee Conduct)*

# COLUMBUS PUBLIC SCHOOLS

Columbus, Nebraska

**ADMINISTRATIVE REGULATION**  
Regulation Code: 402.22-R

Supports Policy: 402.22  
Effective: [Date]

## VIDEO SURVEILLANCE IN THE WORKPLACE

*Administrative Procedures*

### 1. DEFINITIONS

**1.1 Video Surveillance System:** Any system of cameras, monitors, recording devices, and related equipment used to capture, transmit, or store video images of district premises.

**1.2 Authorized Personnel:** Individuals designated by the Superintendent to access, view, or manage video surveillance systems and recordings, including but not limited to the Director of Technology, Director of Operations, building principals, and designated security personnel.

**1.3 Covert Surveillance:** Surveillance conducted through hidden cameras or without notice to those being recorded. Covert surveillance is prohibited except in limited circumstances as described in Section 7 of this regulation.

**1.4 Reasonable Expectation of Privacy:** A legal standard describing locations or circumstances where an individual would reasonably believe their activities are not subject to observation or recording by others.

### 2. INSTALLATION AND PLACEMENT

**2.1 Approval:** All new surveillance camera installations must be approved by the Director of Operations in consultation with the building principal. The Director of Operations shall maintain a current inventory of all surveillance equipment locations.

**2.2 Placement Standards:** Cameras shall be positioned to capture the intended area while minimizing incidental recording of private activities. Camera angles shall not be directed at computer screens displaying personal information, break room seating areas where employees take meals, or areas where employees engage in personal phone calls.

**2.3 Visibility:** Cameras shall be visible and not concealed except in circumstances described in Section 7. Dome cameras that obscure the camera direction are permissible.

**2.4 Signage:** Signs measuring at least 8.5" x 11" stating "VIDEO SURVEILLANCE IN USE" or substantially similar language shall be posted at: (a) all main entrances to district buildings; (b) entrances to parking lots; and (c) additional locations as deemed appropriate by building administration. Sample signage language: "NOTICE: This facility

is equipped with video surveillance cameras for security purposes. By entering this facility, you consent to being recorded."

### **3. AUDIO RECORDING PROCEDURES**

**3.1 Default Setting:** Audio recording capabilities on all surveillance equipment shall be disabled as the default setting.

**3.2 Enabling Audio:** Audio recording may only be enabled upon written approval of the Superintendent and only in limited circumstances where there is a documented security need (e.g., exterior entry points, loading docks). A written justification must be maintained on file.

**3.3 Notice for Audio:** If audio recording is enabled in any location, additional signage must be posted stating: "AUDIO AND VIDEO RECORDING IN USE."

**3.4 School Bus Audio:** Audio recording on school buses is governed by Neb. Rev. Stat. § 79-318 and shall comply with notice requirements under that statute.

### **4. ACCESS TO SURVEILLANCE SYSTEMS**

**4.1 Authorized Access List:** The Superintendent shall maintain a written list of individuals authorized to access surveillance systems. The list shall include: Superintendent, Assistant Superintendent, Director of Technology, Director of Operations, Director of Human Resources, building principals, and designated security personnel.

**4.2 Password Protection:** All surveillance systems shall be password-protected. Passwords shall be changed at least annually and whenever an authorized user's employment ends or access is revoked.

**4.3 Access Log:** The surveillance system shall maintain an electronic log of all user access, including date, time, user identity, and footage accessed. Logs shall be retained for a minimum of one (1) year.

**4.4 Remote Access:** Remote access to surveillance systems shall only be permitted through secure, encrypted connections and only by authorized personnel.

### **5. RETENTION AND STORAGE**

**5.1 Routine Retention:** Video recordings shall be retained for a minimum of thirty (30) days. After thirty days, recordings not subject to a preservation hold may be overwritten or deleted.

**5.2 Extended Retention:** Recordings shall be retained beyond the routine period when: (a) the recording is relevant to a pending or anticipated investigation; (b) the recording is subject to a litigation hold; (c) the recording documents an incident involving injury, property damage, or criminal activity; or (d) the recording has been requested by law enforcement.

**5.3 Preservation Requests:** Any administrator, supervisor, or law enforcement officer may request preservation of specific footage by submitting a written request to the Director of Technology. The request must identify the date, time, location, and reason for preservation.

**5.4 Secure Storage:** All recordings shall be stored on secure, access-controlled servers. Physical recording equipment shall be located in locked rooms accessible only to authorized personnel.

## **6. REQUESTS FOR FOOTAGE**

**6.1 Internal Requests:** District administrators conducting an investigation may request footage by submitting a Video Footage Request Form (Exhibit A) to the Director of Technology. The request must state the purpose, date/time range, and location of the footage requested.

**6.2 Law Enforcement Requests:** Requests from law enforcement shall be directed to the Superintendent or designee. The district will comply with valid subpoenas, warrants, and court orders. In emergency situations involving imminent threat to safety, footage may be provided to law enforcement pending formal legal process.

**6.3 Employee Requests:** Employees who are the subject of an investigation or disciplinary action may request to view relevant surveillance footage through the Director of Human Resources. Such requests will be considered on a case-by-case basis consistent with applicable law.

**6.4 Public Records:** Requests for surveillance footage under the Nebraska Public Records Act shall be processed by the Superintendent's office in accordance with Policy [Public Records Policy Number]. Footage containing images of students is generally exempt from disclosure under FERPA.

## **7. COVERT SURVEILLANCE**

**7.1 General Prohibition:** Covert (hidden) surveillance of employees is prohibited except as provided in this section.

**7.2 Limited Exception:** Covert surveillance may be authorized only when: (a) there is a reasonable, documented suspicion of criminal activity or serious policy violation; (b) overt surveillance would compromise the investigation; (c) the surveillance is approved in writing by the Superintendent; and (d) the surveillance is conducted only in areas where there is no reasonable expectation of privacy.

**7.3 Documentation:** All covert surveillance must be documented in writing before implementation, including the basis for suspicion, the specific area to be monitored, the duration, and the approval signature of the Superintendent.

**7.4 Time Limit:** Covert surveillance shall not exceed thirty (30) days without renewed written authorization.

## 8. TRAINING

**8.1 Authorized Personnel Training:** All individuals authorized to access surveillance systems shall receive training on: (a) this policy and regulation; (b) proper use of surveillance equipment; (c) privacy requirements and prohibited uses; (d) data security and confidentiality; and (e) procedures for handling footage requests.

**8.2 Administrator Training:** Building administrators shall receive training on when and how to request surveillance footage for investigations and the proper handling of footage in disciplinary matters.

## 9. EMPLOYEE ACKNOWLEDGMENT

All employees shall sign an acknowledgment form (Exhibit B) confirming receipt of notice regarding the district's video surveillance policy. The signed acknowledgment shall be maintained in the employee's personnel file. New employees shall sign the acknowledgment as part of the onboarding process.

## 10. VIOLATIONS

Violations of this regulation by district employees may result in disciplinary action up to and including termination. Specific violations include:

- Unauthorized access to surveillance systems or recordings
- Unauthorized duplication or distribution of recordings
- Tampering with, disabling, or obstructing surveillance equipment
- Using surveillance for prohibited purposes
- Sharing access credentials with unauthorized individuals
- Failure to report known violations of this regulation

**Exhibits:**

402.22E1: Exhibit 1 Video Footage Request Form

402.22E2: Exhibit 2 Employee Acknowledgment of Video Surveillance Policy

402.22E3: Exhibit 3 Covert Surveillance Authorization Form

*Implements: Board Policy 402.22*

**COLUMBUS PUBLIC SCHOOLS**  
**402.22E1**

**EXHIBIT 1: VIDEO FOOTAGE REQUEST FORM**

**Instructions:** Complete this form to request video surveillance footage for investigative or documentation purposes. Submit to the Director of Technology. Allow 2-3 business days for processing.

<b>Date of Request:</b>	
<b>Requestor Name:</b>	
<b>Position/Title:</b>	
<b>Building/Location:</b>	

**Footage Requested**

<b>Date(s) of Footage:</b>	
<b>Time Range:</b>	From: _____ To: _____
<b>Camera Location(s):</b>	
<b>Purpose of Request:</b>	<input type="checkbox"/> Student discipline investigation <input type="checkbox"/> Employee investigation <input type="checkbox"/> Safety/security incident <input type="checkbox"/> Property damage/theft <input type="checkbox"/> Law enforcement request <input type="checkbox"/> Other: _____
<b>Brief Description of Incident:</b>	

Requestor Signature: \_\_\_\_\_ Date: \_\_\_\_\_

Supervisor Approval: \_\_\_\_\_ Date: \_\_\_\_\_

**FOR TECHNOLOGY DEPARTMENT USE ONLY**

Date Received: _____	Format: <input type="checkbox"/> USB <input type="checkbox"/> DVD <input type="checkbox"/> Secure Link
Footage Available: <input type="checkbox"/> Yes <input type="checkbox"/> No	Processed By: _____
Date Provided: _____	Notes: _____

**COLUMBUS PUBLIC SCHOOLS**  
**402.22E2**

**EXHIBIT 2: EMPLOYEE ACKNOWLEDGMENT OF VIDEO SURVEILLANCE POLICY**

I acknowledge that I have received and reviewed Columbus Public Schools Board Policy 402.22 and Administrative Regulation 402.22-R regarding Video Surveillance in the Workplace.

I understand that:

1. The district utilizes video surveillance systems on school property for safety, security, and investigative purposes.
2. Video surveillance may be conducted in hallways, entrances, parking lots, common areas, and other locations where there is no reasonable expectation of privacy.
3. Video surveillance is prohibited in restrooms, locker rooms, changing areas, lactation rooms, and other areas where employees have a reasonable expectation of privacy.
4. Audio recording is generally disabled on surveillance systems. If audio recording is enabled in specific locations, notice will be posted.
5. Video recordings may be used in connection with investigations of policy violations, safety incidents, or potential criminal activity.
6. I may report concerns about improper surveillance practices to the Director of Human Resources or the Superintendent without fear of retaliation.
7. Unauthorized access to, duplication of, or distribution of surveillance recordings is prohibited and may result in disciplinary action.

By signing below, I confirm that I have read and understand the district's video surveillance policy and regulation, and I have had the opportunity to ask questions.

\_\_\_\_\_  
Employee Name (Print)

\_\_\_\_\_  
Employee Signature

\_\_\_\_\_  
Date

\_\_\_\_\_  
Building Assignment

*This form will be retained in the employee's personnel file.*

**COLUMBUS PUBLIC SCHOOLS**  
**402.22E3**

**EXHIBIT 3: COVERT SURVEILLANCE AUTHORIZATION FORM**  
**CONFIDENTIAL**

*This form must be completed and approved by the Superintendent PRIOR to implementing any covert (hidden) surveillance. Covert surveillance is permitted only in limited circumstances as described in Administrative Regulation 4022-R, Section 7.*

<b>Date of Request:</b>	
<b>Requesting Administrator:</b>	
<b>Location to be Monitored:</b>	
<b>Proposed Duration:</b>	Start Date: _____ End Date: _____

**Justification (All items must be addressed)**

**1. Describe the reasonable suspicion of criminal activity or serious policy violation:**

---

---

---

**2. Explain why overt surveillance would compromise the investigation:**

---

---

**3. Confirm the proposed location has no reasonable expectation of privacy:**

I confirm the proposed location is not a restroom, locker room, private office, lactation room, or other area with a reasonable expectation of privacy.

Requesting Administrator Signature: \_\_\_\_\_ Date: \_\_\_\_\_

## SUPERINTENDENT APPROVAL

APPROVED     DENIED

Conditions or Limitations (if any):

---

---

Superintendent Signature: \_\_\_\_\_ Date: \_\_\_\_\_

*This form is confidential and shall be maintained in a secure file in the Superintendent's office. Covert surveillance may not exceed 30 days without renewed authorization.*

<b>Last Name</b>	<b>First Name</b>
Abrajan-Gomez	Jasmin
Adame	Noah
Ahmed	Thakik
Alba	Terisa
Alexander	Taylor
Allsman	Logan
Alvarado	Arlett
Arevalo-Garcilazo	Ana
Arroyo	Avianna
Baeza	Davion
Baker	Katherin
Banda-Pompa	Elier
Barbosa-Lopez	Johan
Batista-Guerra	Adis
Bedolla-Lemus	Jorge
Bethune	Ashtyn
Bishop	Derick
Blezek	Samantha
Bloyd	Peyton
Bonilla	Hector
Borg	Cohen
Braithwait	Laitenn
Brayton	Kaylea
Bronson	Brooke
Browning	Logan
Cabrera-Lazo	Diego
Caceres	Daniel
Calderon-Medina	Bryan
Calero-Perez	Roberto
Cardona-Morales	Allison
Carlson	Macy
Carnes	Maximilian
Carreto-Perez	Lesbia
Cazares	Memphis
Cermak	Ashlynn
Cole	Zack
Comley	Reed
Contreras	Antwan
Coria	Yaretcy
Coughtry	Jared
Damian-Rios	Brianna
David-Castorena	Omar

Dearcos	Evangelina
Delano	Jaeston
Dewine	Ace
Diaz-Franco	Katya
Diehm	Jaxson
Dittmar	Taley
Donoghue	Sally
Eckert	Charls
Edwards	Noah
Eisenmann	Carter
Engel	Emme
Erb	Paighton
Escobar-Romero	Kevin
Espinoza-Manzano	Jocelin
Esso-Bissu	Wesly-Djessie
Estrada	Sophie
Feik	Jersie
Flores-Franco	Yasmin
Flowers	Lorenzo
Foster	Kaylee
Franco-Monzon	Oscar
Garcia	Alexa
Garcia-Hernandez	Luis
Garcia-Juarez	Alexis
Garcia-Ortega	Maria
Gehring	Rory
Gernstein	Jayden
Gerou	Autumn
Gillespie	Grady
Glasshoff	Kara
Goc	Molly
Gomez-Cortez	Betcy
Gomez-Vazquez	Melissa
Gonzalez	JuanDiego
Gonzalez	Keilyn
Gonzalez-Hernandez	Camila
Gonzalez-Juarez	Monserrat
Gonzalez-Sandoval	Alan
Grape	Kysen
Guerra-Ontiveros	Salvador
Gutierrez-Arenas	William
Guzman-Mendez	John
Hadaway	Kiersten

Hall	Jenna
Haynes	Kingston
Heidemann	Kendall
Heidtbrink	Emma
Held	Brooklyn
Henderson	Breaunna
Hernandez	Alexander
Hernandez	Juliana
Hernandez	Juliana
Hernandez-Herrera	Jason
Hernandez-Ibarra	Itzell
Hernandez-Ruiz	Dante
Herrera	Joaquin
Hoesing	Kalista
Holys	John
Hoskovec	Samantha
Humpal	Landon
Humpal	Logan
Ibarra	Izalla
Izaguirre-Pineda	Vivian
Jackson	Stella
Jaeger	Emersyn
Janicek	Kaitlyn
Jensen	Lillian
Jessen	Aaron
Jose-Garcia	Hailey
Juarez	Juan
Juzaino-Madrid	Caleb
Kallhoff	Joseph
Kapels	Carley
Kay	Dylan
Kibalya	Ivana
Kitt	Caleb
Klee	Savannah
Klozenbucher	Hailey
Krepel	Keedyn
Krueger	Matthew
Kudron	Alayna
Kush	Ava
Lantis	Joseph
LaPointe	Jordyn
Larsen	Josie
Lauterbach	Trenton

Leon	Pedro
Liermann	Damon
Lighter	Leonidas
Little Elk	Lakrysta
Logan	Elyjah
Long	Kyrstyn
Lopez	Natalia
Lopez-Azamar	Angel
Lopez-Morales	Cristian
Lopez-Paz	Breiner
Lopez-Vela	Moises
Loredo-Luevano	Dafne
Luce	Magdeline
Luebbe	Eastyn
Maboundou-Beatsengue	Fermelie Precieuse
Manzano	Angelina
Marker	Emma
Marroquin-Carreto	Wilder
Martinez	Selena
Martinez-Mireles	Steven
Mauricio	Ahylin
McFarland	Jakson
Mendoza	Natalie
Mendoza-Diaz	Leandro
Miller	Sydney
Montes	Diana
Moreno-Coria	Isidro
Morgan	Ayden
Moseman	Elena
Mouandza	Hattie Chrismaine
Mueller	Sarah
Munford	Isobel
Munoz	Luis
Murphy	Larissa
Natalio	Alberto
Nava-Ramirez	Juan
Nelson	Jayce
Nickolite	Jocelyn
Nolan	Winona
O'Kane	Emma
Oliva-Rumbaut	Maria
Orozco-Hernandez	Lorenzo
Palma	Alyssa

Pastrana-Castillo	Brenda
Pedraza-Castillo	Emiliano
Pedroza-Nava	Jacquelyn
Pena-Marino	Jeily
Petermann	Leticia
Petersen	Cash
Petersen	Mason
Petersen	Paul
Pina	Jasmine
Pineda-Sorto	Denilson
Prokopec	Bronwyn
Quail	Andrew
Rains	Maverick
Ramirez	Zarai
Rausch	Collin
Rawls	Xavier
Reeder	Bryson
Renteria	Carter
Renteria	Conrad
Retureta-Hernandez	Maria
Rivas-Romero	Diana
Rivas-Romero	Diego
Roberts	Greta
Rodriguez	Evelyn
Rodriguez	Rosario
Rodriguez-Espino	Nataly
Rodriguez-Navas	Jose
Rodriguez-Sanchez	Jorge
Roebuck	Raegan
Roehl	Morgan
Roehl	Zoe
Rozikov	Omar
Ruiz	Uriel
Saldana	Omar
Salinas	Honey
Sanchez	Jasmine
Santillan	Natalie
Santos-Delgado	Jhon
Schott	Spencer
Schumacher	Kiera
Sedlacek	Carter
Shea	Ruby
Shevlin	Maggie

Slizoski	Malynn
Sloma	Brynn
Smith	Tristan
Smolek	Colby
Snyder	Dayton
Stauss	Jacob
Stempek	Teegan
Stuhr	Cooper
Tadeo-Coria	Zitlaly
Taylor	Isaiah
Tellez-Gomez	Gamaliel
Terry	Dakota
Torres-Fiallo	Briana
Urkoski	Kolton
Van Buskirk	Jace
Vasina	Reece
Velasquez-Gallardo	Luis
Vetick	Chayston
Villafuerte-Sagastume	Jered
Voichoskie	Michael
Wang	Si Bo
Webster	Annya
Wemhoff	Keagen
Weverka	Braxtyn
Weverka	Nyomi
White	Ty
Williams	Carter
Williams	Connor
Williams	Nolan
Wilson	Micah
Young	Delaney
Young	Gavin
Zarate	Alicia