

## Raymond Central Public Schools (District 0161) Board of Education Regular Meeting

Wednesday, February 14, 2024 at 6:00 PM

Raymond Central Jr-Sr High School - Mustang Room

1800 West Agnew Road

Raymond, NE 68428-9783

**Present:** Mary Benes, Brad Breitreutz, Cathy Burklund, Bill Lange, **Absent:** Matt Blanchard, Derek Matulka. Also in attendance were: Lynn Johnson, Superintendent; Mark Smith, Jr-Sr High Principal; Tony Kobza, Activities Director/Asst Principal; Steve Rose, Elementary Principal; Deb Kruse, Asst Elementary Principal; and Amanda Coufal, SpEd Coordinator.

### Call to Order and Pledge of Allegiance

President Breitreutz called the meeting to order at 6:00 PM and the Pledge of Allegiance was said.

### Motion to Excuse Board Member's Absence

Motion by Lange, second by Burklund to excuse the absence of Derek Matulka but not approve the absence of Matt Blanchard. RCV 4-0. Motion carried.

### Open Meeting Law

The audience was reminded that Open Meeting Laws would be followed.

### District Mission Statement

*The Raymond Central community is committed to providing a positive, challenging learning environment which prepares each individual to be a responsible citizen in an ever-changing society.*

### Consent Agenda

Moved by Lange, seconded by Benes to approve the consent agenda as presented including the regular meeting minutes of January 10, 2024; January financial statement; monthly bills; and Board policies with no changes in Series 6000-Instruction to be noted with Review Date of February 14, 2024 (6000-General Policy Statement; 6020-The Program of Instruction; 6111-Classroom Environment; 6114-Emergencies; 6116-Emergency Dismissal or Cancellation; 6117-Ceremonies, Observances, and Pledge; 6120-Safe Schools Policy; 6210-Curriculum-Development and Adoption; 6211-Curriculum-Assessments; 6212-Assessments-Academic Content Standards; 6220-Experimental Innovative Program; 6240-Homework; 6260-Guidance; 6270-Field Trips; 6280-Activities; 6281-Activity Funds Management; 6282-School Colors; 6284-Initiations and Hazing; 6286-Return to Learn after Cancer; 6300-Review of Instructional Materials; 6310-Textbook Loans; 6360-Recognition of Religious Beliefs and Customs; 6363-Purpose of Religion in the Curriculum; 6370-Multicultural Education; 6380-Equal Opportunity/Instruction Program; 6390-Controversial Issues; 6410-Family Engagement Policy; 6600-Sped Policy; 6700-Firearm Policy; 6900-Chronic Infectious Disease Practice and Procedure; 6920-Self Management of Asthma-Anaphylaxis-Diabetes; 6920a-Asthma Medical Management Plan Form; 6920b-Diabetes Medical Management Plan Form; 6921-Seizure Safe Schools). RCV 4-0. Motion carried.

### Regular Minutes of January 10, 2024

## **Raymond Central Public Schools (District 0161) Board of Education Regular Meeting**

Wednesday, January 10, 2024 at 6:00 PM

Raymond Central Jr-Sr High School - Mustang Room

1800 West Agnew Road

Raymond, NE 68428-9783

**Present:** Mary Benes, Brad Breikreutz, Cathy Burklund, Bill Lange, Derek Matulka, **Absent:** Matt Blanchard. Also attending were: Lynn Johnson, Superintendent; Mark Smith, Jr-Sr High Principal; Tony Kobza, Activities Director/Asst Principal; Steve Rose, Elementary Principal; Deb Kruse, Asst Elementary Principal; and Amanda Coufal, SpEd Coordinator.

### Call to Order and Pledge of Allegiance

President Breikreutz called the meeting to order at 6:00 PM and the Pledge of Allegiance was said.

### Motion to Excuse Board Member's Absence

Motion by Lange, second by Benes to excuse the absence of Matt Blanchard. RCV 5-0. Motion carried.

### Open Meeting Law

The audience was reminded that Open Meeting Laws would be followed.

### District Mission Statement

*The Raymond Central community is committed to providing a positive, challenging learning environment which prepares each individual to be a responsible citizen in an ever-changing society.*

### Annual Organizational Meeting

#### Elections of officers

#### Elect President

Moved by Burklund, seconded by Benes that Brad Breikreutz be elected as Board President to serve a term of one year, or until the person's successor is elected and qualified. RCV 4-0, Breikreutz abstained. Motion carried.

#### Elect Vice President

Moved by Matulka, seconded by Lange that Cathy Burklund be elected as Board Vice President to serve a term of one year, or until the person's successor is elected and qualified. RCV 4-0, Burklund abstained. Motion carried.

#### Elect Secretary

Moved by Breikreutz, seconded by Burklund that Bill Lange be elected as Board Secretary and the Superintendent's Administrative Assistant as Exofficio Recording Secretary. RCV 4-0, Lange abstained. Motion carried.

#### Elect Treasurer

Moved by Burklund, seconded by Lange that Mary Benes be elected as Board Treasurer and the District Bookkeeper as Exofficio Treasurer. RCV 4-0, Benes abstained. Motion carried.

#### Review Board Policy 8272 Code of Ethics

The Board reviewed and signed a copy of Policy 8272 Code of Ethics.

#### Approval of committees, positions, and designations

Discuss, Consider and Take Action to approve Perry Law Firm and KSB Law Firm as the primary legal counsel.

Moved by Matulka, seconded by Benes to approve Perry Law Firm and KSB Law Firm as the primary legal counsel. RCV 5-0. Motion carried.

Discuss, Consider President's appointment to board committee and representative positions

Moved by Matulka, seconded by Benes to appoint 2024 Board Committees as follows: Curriculum & American Civics: Cathy Burklund-Chair, Bill Lange, Derek Matulka; Facilities & Transportation: Derek Matulka-Chair, Cathy Burklund, Bill Lange; Finance Committee: Matt Blanchard-Chair, Brad Breitreutz, Cathy Burklund; Negotiations Committee: Matt Blanchard-Chair, Mary Benes, Bill Lange; Policy Committee: Brad Breitreutz-Chair, Mary Benes, Matt Blanchard. RCV 5-0. Motion carried.

Discuss, Consider and Take Necessary Action to select Jones Bank, Ceresco Bank and First Northeast Bank of Nebraska as depositories of record

Moved by Burklund, seconded by Matulka to select Jones Bank, Ceresco Bank and First Northeast Bank of Nebraska as depositories of record. RCV 5-0. Motion carried.

Discuss, Consider and Take Necessary action to select the Waverly News, or other newspapers of general circulation in the event of the need to publish a notice on short notice, as District Newspapers of record.

Moved by Burklund, seconded by Lange to select the Waverly News, or other newspapers of general circulation in the event of the need to publish a notice on short notice, as District Newspapers of record. RCV 5-0. Motion carried.

Discuss, Consider and Take Necessary Action to appoint Superintendent as the Every Student Succeeds Act (ESSA) and all federal programs representative

Moved by Matulka, seconded by Lange to appoint the Superintendent as Every Student Succeeds Act (ESSA) and all federal programs representative. RCV 5-0. Motion carried.

#### Review the plan for Review of Board Policy

The proposed schedule to finalize review of Policies 1000-9000 was discussed. We are currently on the 6000s. This process should be completed at the June Board Meeting.

#### Disseminate to Board members the conflict of interest policies

Conflict of interest policies 8260, 8261, and 8270 were disseminated to Board members.

#### Consent Agenda

Moved by Matulka, seconded by Benes to approve the consent agenda as presented including the regular meeting minutes of December 13, 2023; December financial statement; and monthly bills. RCV 5-0. Motion carried.

#### Regular Minutes of December 13, 2023

## Financial Statement/Report

### Monthly Bills

### Correspondence/Recognition

### Public Forum

### Reports

#### Student Board Member Report

##### **Submitted by Rosalie Tvrdy, Student Body President**

Hello, and Happy New Year! I hope you all had a wonderful Christmas, and that you all are excited for the second semester! Because I am involved in a lot of activities at school, I am very happy to share some new updates from these extracurricular activities. FBLA was able to purchase a T-shirt press, in which we have made an activity where the chapter members get to make their own chapter T-shirts for this year! We were supposed to have a goodwill donation soup supper yesterday where we were able to work concessions, have people make T-shirts on the press and buy them from us, give back to the community, while fundraising for our chapter. We will have to reschedule because of the snow day. In Mrs. Schaffer's classes, students have been able to design shirts, including shirts for sports, trap, the truck row, and generic Mustang apparel. Many students were very excited about this, and we are hoping to have the T-shirt press at more concessions that FBLA gets to work. We plan to have more members and students create shirt designs and have more for next year's fall activities. FBLA also has many members that are going to be attending the State Leadership Conference. We are preparing study nights so that students can come in and work on their presentations and study for the tests and events that they are going to do at the competition. Another activity that I would like to highlight is Student Council. The Student Council started a toy and winter wear donation drive last semester at the beginning of December, and the members were required to bring two items. We had many donations, all which went back into the community through the caring shelves here at the high school.

When we came back to school, we had an assembly to review the Mustang Way, and the Mustang ABC's. Those include Academics, Behavior, and Community. The administration also told us about our attendance records and how they are very good, and we have made goals to make them better. We also had a 95% passing and 5% failing for all of the grades throughout high school. This is something that administration was extremely proud of, and they made a goal to increase the passing grades even more this semester. They told us that just showing up and putting in the work would help everyone throughout the school, and that they were very proud of the things that we have accomplished already. Again, Happy New Year, and here's to a great second semester!

#### Superintendent's Report

##### Report on Personal Finance

##### NASB Monthly Update

##### Safety Report

During our professional development on January 3, the entire staff gathered at the Jr/Sr High School and Kevin Kavan, Security Director of Fremont Public Schools, helped to educate us on reunification procedures. We reviewed our district protocols, and then we did some walk through exercises where staff members assumed the various roles and executed them. Good conversation and discussion resulted from this learning opportunity. Our goal is to have at least 2 drills with students during second semester and to get additional outside eyes on our drills and procedures (likely other school resource officers).

On this same day, we had Taira Masek, Mental Health Coordinator from ESU#2, come on site and train our staff in QPR protocol to help prevent suicide. It is a suicide awareness program. QPR stands for

Question. Persuade. Refer. This one hour session was very informative and helped to debunk some of the fallacies that we may have about working with persons who may be considering suicide.

## Facilities Report

Jared and I continue to work on the items that the Facilities and Transportation Committee and the board have identified as priority items for the spring/summer.

- Jared is obtaining the quotes for the carpet across the district. In phase 1 (of potentially 3 or 4 phases) we are targeting carpet in the Jr/Sr campus senior wing and Valparaiso first floor. The quotes obtained will give us a better idea if we can expand that scope or need to shrink that scope.
- Jared is working with Mechanical Sales to arrange the direct purchase of the desired Daikin heat pumps. We have identified approximately \$160,000 for phase 1 of this project. Jared believes that we can install about 9 heat pumps in phase 1. Later in the agenda the board will be asked to approve the purchase of heat pumps.
- Jaxn is working with Kidwell on the door access and cameras at the two elementary schools. We are still looking at spring install and completion.
- The FB sound system is in front of the board this month for approval.
- Tony is working on getting the stage mats replaced and he is working to obtain quotes for the basketball clock/lights and safety straps.
- Jared is working to get updated quotes on playgrounds. The three quotes that we obtained last year are outdated. One of the three quotes was less than the others and that will likely be our vendor of choice.
- There was a recall on the electrical bus just as Omaha Truck was readying to deliver it. Omaha Truck is still waiting for factory details, so a timeline is not known.
- We were able to use a different electric vehicle to commission our charging station. Once the bus is received, that is ready to roll.

## Important Upcoming Dates:

### Board Committee Reports

Curriculum & American Civics Committee (Burklund-chair, Lange, Matulka)

Facilities & Transportation Committee (Blanchard-chair, Burklund, Matulka)

Finance Committee (Blanchard-chair, Breitreutz, Burklund)

Negotiations Committee (Blanchard-chair, Benes, Lange)

Policy Committee (Breitreutz-chair, Benes, Lange)

### Old Business

### New Business

Discuss, Consider and Take Necessary Action to surplus a shaper and a jet bandsaw

Moved by Lange, seconded by Matulka to approve the surplus of a shaper/router and a jet bandsaw. RCV 5-0. Motion carried.

Discuss, Consider and Take Necessary Action to approve a quote from KCAV to update sound system and speakers at football field

The Facilities & Transportation Committee reviewed the football field sound system options available to us at this time. They felt that the system needed to be repaired and the KCAV quote is the most

reasonably priced quote. It was moved by Benes, seconded by Burklund to approve the quote from KCAV at \$42,070.64. RCV 5-0. Motion carried.

#### Discuss and Consider the School District Report Card

State test scores and school classifications for the 2022-23 school year were released from the Nebraska Department of Education (NDE). NDE classifies schools across our state from "Needs Support to Improve" to "Excellent." State test scores, student academic growth, English language/math proficiency, and attendance in the school determine each school's classification.

Parents/guardians who have a student(s) that is in a grade that takes the NSCAS test will receive information about their child's performance. Student data has always guided our instruction and we are constantly working to build on our instruction and improve outcomes for all students.

#### Discuss, Consider and Take Necessary Action to approve the purchase of heat pumps for Valparaiso elementary

Replacement of the heat pumps at Valparaiso is a priority for the district. We intend to replace these in three phases and we have targeted approximately \$160,000 for this first phase. After discussion, it was felt that the best way to proceed is to purchase the heat pumps directly from the vendor and then to RFP the electrical, fire, and control system. It was moved by Matulka, seconded by Burklund to approve the purchase of 8 Daikin heat pumps from Mechanical Sales in the amount not to exceed \$59,315 and then continue to move the process along. RCV 5-0. Motion carried.

#### Next Regular Board Meeting

The next regular Board of Education Meeting will be held Wednesday, February 14, 2024.

#### Adjournment

Motion by Breitkreutz, second by Matulka to adjourn the meeting at 7:46 PM. RCV 5-0. Motion carried.





**Raymond Central Public Schools**  
**General Fund Comparison to Previous Year**  
**January 2024**

---

	1/1/2024 - 1/31/2024	1/1/2023 - 1/31/2023
Balance - Beginning of Month	\$1,931,809.03	\$1,733,656.63
Receipts	\$1,537,829.00	\$1,210,295.79
Interest Earned	\$5,850.57	\$2,733.71
Disbursements Outstanding Cks	<u>-\$896,506.25</u>	<u>-\$785,835.72</u>
Balance - End of Month	\$2,578,982.35	\$2,160,850.41



**Raymond Central Public Schools**  
**General Fund Receipts Jan. 2024**

<b>LANCASTER COUNTY TREASURER</b>		
TAXES		\$376,714.43
PERSONAL PROP TAXES		\$16,645.81
MOTOR VEHICLE TAXES		\$34,347.74
FINES & FEES		\$1,087.50
MOTOR VEHICLE PRO TAXES		\$2,260.71
<b>SAUNDERS COUNTY TREASURER</b>		
TAXES		\$586,036.87
MOTOR VEHICLE TAXES		\$21,697.02
FINES & FEES		\$3,663.76
MOTOR VEHICLE PRO TAXES		\$1,770.51
<b>SEWARD COUNTY TREASURER</b>		
TAXES		\$15,214.64
MOTOR VEHICLE TAXES		\$532.73
FINES & FEES		\$70.34
MOTOR VEHICLE PRO TAXES		\$54.41
<b>BUTLER COUNTY TREASURER</b>		
TAXES		\$756.10
FINES & FEES		\$4.65
MOTOR VEHICLE PRO TAXES		\$3.91
<b>VILLAGE OF DAVEY</b>		
LIQUOR LICENSE FEE		\$300.00
<b>STATE OF NEBRASKA</b>		
STATE APPORTIONMENT		\$150,715.01
STATE AID		\$120,810.00
SPED		\$160,881.00
MEDICAID		\$11,418.23
<b>PRE K TUITION</b>		
PRE K TUITION		\$3,000.00
<b>FEDERAL RECEIPTS</b>		
PERKINS VOCATIONAL EDUC		\$6,687.96
IDEA PRESCHOOL		\$928.00
<b>RCPS HOT LUNCH FUND</b>		
JAN PAYROLL EXPENSES		\$22,128.34
<b>JONES BANK</b>		
GENERAL FUND INTEREST -JAN		\$5,850.57
<b>NON-REVENUE RECEIPTS</b>		
FARMERS COOP STOCK EQUITY PAYT		\$64.33
EMPLOYEE JURY PAYT		\$35.00
<b>TOTAL</b>		<b>\$1,543,679.57</b>

JANUARY 2024	Percent of Year Completed		41.67%			
2023-2024 RECEIPTS		M-T-D	Y-T-D	Y-T-D	Y-T-D	Y-T-D
	2023-2024	RECEIVED	RECEIVED	RECEIVED	% Received	% Received
ACCOUNT	ANTICIPATED	2023-2024	2023-2024	2022-2023	2023-2024	2022-2023
Property Taxes	\$8,116,238.00	\$978,722.04	\$2,369,825.34	\$2,141,217.12	29.20%	26.32%
Motor Vehicle Tax	\$499,000.00	\$56,577.49	\$254,079.82	\$239,446.37	50.92%	53.21%
Public Power Tax (5% Gross)	\$39,000.00	\$0.00	\$0.00	3,826.29	0.00%	10.93%
Carlne Taxes	\$2,530.00	\$0.00	\$539.88	\$474.26	21.34%	15.81%
Other Tuition	\$0.00	\$0.00	\$0.00	\$0.00	0.00%	0.00%
Interest	\$8,000.00	\$5,850.57	31,402.17	11,401.47	392.53%	356.30%
Local License Fees	\$3,900.00	\$300.00	\$300.00	\$300.00	7.69%	15.00%
Other Local Receipts(Pre-K)	\$12,000.00	\$3,000.00	11,832.62	5,085.14	98.61%	42.38%
Fines & License Fees	\$26,000.00	\$4,826.25	\$16,718.10	\$14,417.80	64.30%	48.06%
ESU Receipts	\$7,300.00	\$0.00	2,644.78	\$5,157.96	36.23%	73.69%
State Aid	\$1,213,974.00	\$120,810.00	615,551.00	481,740.00	50.71%	50.00%
Special Education	\$972,397.00	\$160,881.00	321,294.00	148,164.00	33.04%	30.24%
Special Educ. Transportation	\$21,000.00	\$0.00	\$0.00	\$0.00	0.00%	0.00%
Homestead Exemption	\$0.00	\$0.00	\$0.00	4,801.25	0.00%	0.00%
High Ability Learners	\$5,500.00	\$0.00	\$0.00	\$5,909.00	0.00%	98.48%
Pro-Rate Motor Vehicles	\$19,000.00	\$4,089.54	\$6,610.41	\$4,642.96	34.79%	25.79%
State Apportionment	\$103,000.00	\$150,715.01	\$150,715.01	\$0.00	146.33%	0.00%
Relief to Property Tax Payers	\$0.00	\$0.00	\$0.00	\$0.00	0.00%	0.00%
Other State Receipts	\$23,000.00	\$0.00	\$0.00	\$0.00	0.00%	0.00%
Personal Property Tax Credit	\$0.00	\$16,645.81	30,254.52	24,834.08	100.00%	100.00%
Title I /II Funds	\$49,000.00	\$0.00	\$0.00	\$69,481.00	0.00%	257.34%
Other Federal Receipts	\$0.00	\$0.00	\$0.00	\$0.00	0.00%	0.00%
SPED IDEA Grant PreK	\$124,000.00	\$928.00	\$928.00	\$0.00	0.75%	0.00%
Private Grants-College Access	\$3,500.00	\$0.00	\$3,150.00	\$5,601.61	90.00%	100.00%
Carl Perkins	\$25.00	\$6,687.96	6,687.96	\$0.00	26751.84%	0.00%
Other Non-Revenue Receipts	\$1,000.00	\$99.33	\$9,682.18	3,454.03	968.22%	100.00%
Ag Land Property Credit	\$0.00	\$0.00	\$4,944.38	\$0.00	100.00%	100.00%
ESSER (COVID-19) Funds	\$0.00	\$0.00	\$0.00	\$0.00	100.00%	0.00%
Sale of Property	\$3,000.00	\$0.00	\$0.00	\$0.00	0.00%	0.00%
MIPS-Medicaid-Public Schools	\$8,900.00	\$11,418.23	\$26,470.95	\$8,043.71	297.43%	85.57%
TransferOther Fund/ Imprest	\$0.00	\$0.00	\$0.00	\$60.00	0.00%	0.00%
Insurance Adjustments	\$1,000.00	\$0.00	\$0.00	\$9,231.50	0.00%	100.00%
<b>TOTAL</b>	<b>\$11,262,264.00</b>	<b>\$1,521,551.23</b>	<b>\$3,863,631.12</b>	<b>\$3,187,289.55</b>	<b>34.31%</b>	<b>30.55%</b>
2023-2024 DISBUREMENTS		M-T-D	Y-T-D	Y-T-D	Y-T-D	Y-T-D
	2023-2024	DISBURSED	DISBURSED	DISBURSED	% Disbursed	% Disbursed
CATEGORY	BUDGET	2023-2024	2023-2024	2022-2023	2023-2024	2022-2023
Instructional Services	\$5,285,000.00	\$386,613.05	\$1,966,590.04	1,861,645.35	37.21%	35.76%
Special Education	\$2,017,427.00	\$146,233.59	\$865,489.86	\$680,324.86	42.90%	34.07%
Guidance	\$227,900.00	\$28,498.22	143,840.89	97,111.82	63.12%	42.61%
School Health Nurse	\$112,750.00	\$9,168.01	46,004.75	46,717.51	40.80%	40.55%
Safety & Security	\$52,151.00	\$0.00	29,926.42	\$21,622.82	57.38%	41.46%
Activities	\$95,020.00	\$6,645.89	\$67,793.67	\$43,184.03	71.35%	45.45%
Media, Technology	\$710,125.00	\$26,818.26	\$207,630.17	\$244,460.16	29.24%	34.42%
Gen.Admin (Supt/BOE/Legal)	\$428,800.00	\$41,768.90	\$151,424.84	\$135,681.75	35.31%	31.64%
School Admin (Principals)	\$762,100.00	\$57,013.48	\$291,176.30	\$281,131.60	38.21%	36.89%
Business	\$322,600.00	\$10,554.63	\$62,291.56	66,190.57	19.31%	20.52%
Operation of Plant	\$789,500.00	\$71,732.22	\$278,244.11	\$247,694.87	35.24%	31.37%
Maintenance of Plant	\$517,500.00	\$40,565.10	\$164,902.45	\$106,761.28	31.87%	20.63%
Pupil Transportation	\$536,549.00	\$43,013.31	\$500,168.09	\$124,825.91	93.22%	23.26%
Fed. Grants (Title,Perkins)	\$129,975.00	\$5,898.65	\$39,242.02	\$52,366.69	30.19%	40.29%
Transfers	\$0.00	\$0.00	\$0.00	\$0.00	0.00%	0.00%
<b>TOTAL</b>	<b>\$11,987,397.00</b>	<b>\$874,523.31</b>	<b>\$4,814,725.17</b>	<b>\$4,008,719.22</b>	<b>40.16%</b>	<b>33.51%</b>
Cash Reserves in General Fund	\$1,990,000.00			\$0.00	0.00%	0.00%
<b>TOTAL</b>	<b>\$13,977,397.00</b>		<b>\$4,814,725.17</b>			

	Y-T-D
2022-2023	2023-2024
ANTICIPATED	PREVIOUS MO
\$8,135,208.00	\$1,391,103.30
\$450,000.00	\$197,502.33
\$35,000.00	\$0.00
\$3,000.00	\$539.88
\$0.00	\$0.00
\$3,200.00	25,551.60
\$2,000.00	\$0.00
\$12,000.00	8,832.62
\$30,000.00	\$11,891.85
\$7,000.00	2,644.78
\$963,483.00	494,741.00
\$490,000.00	160,413.00
\$21,000.00	\$0.00
\$0.00	\$0.00
\$6,000.00	\$0.00
\$18,000.00	\$2,520.87
\$70,000.00	\$0.00
\$0.00	\$0.00
\$23,000.00	\$0.00
\$0.00	8,664.33
\$27,000.00	\$0.00
\$0.00	\$0.00
\$123,000.00	\$0.00
\$0.00	\$3,150.00
\$500.00	\$0.00
\$0.00	\$9,582.85
\$0.00	\$4,944.38
\$0.00	\$0.00
\$3,000.00	\$0.00
\$9,400.00	\$15,052.72
\$0.00	\$0.00
\$0.00	\$0.00

**\$10,431,791.00      \$2,337,135.51**

	Y-T-D
2022-2023	2023-2024
BUDGET	PREVIOUS MO
\$5,206,425.00	\$1,579,976.99
\$1,996,647.00	\$719,256.27
\$227,900.00	115,342.67
\$112,750.00	36,836.74
\$52,151.00	29,926.42
\$95,020.00	\$61,147.78
\$710,125.00	\$180,811.91
\$428,800.00	\$109,655.94
\$762,100.00	\$234,162.82
\$322,600.00	\$51,736.93
\$789,500.00	\$206,511.89
\$517,500.00	\$124,337.35
\$536,549.00	\$457,154.78
\$129,975.00	\$33,343.37
\$75,000.00	\$0.00
<b>\$11,963,042.00</b>	<b>\$3,940,201.86</b>
<b>\$1,944,079.00</b>	<b>\$1,939,135.00</b>
<b>\$13,907,121.00</b>	



**Raymond Central Public Schools**  
**Financial Report 1/31/2024**

**GENERAL FUND**

Purpose: Pays day to day expenses for District

Funded by: Local Taxes, State/Fed Reimb. for SPED, State Aid, Title 1, other misc. grants

For RC: Salaries, benefits, educ expenses, technology, building and grounds maintenance, transportation

Cash Balance - Jan. 1, 2024	\$1,931,809.03
Jan. Receipts	\$1,543,679.57
Jan. Disbursements	<u>-\$896,506.25</u>
Cash Balance - Jan. 31, 2024	\$2,578,982.35

**LUNCH FUND**

Purpose: Pays all expenses for Hot Lunch program including kitchen payroll.

Funded by: Parent/Student/Staff payments for meals and State/Fed Reimb. for meals served.

For RC: Salaries, benefits for HL staff, food, milk, supplies, equipment, repairs associated with HL program.

Note: General Fund can transfer funds into HL account if needed. No transfers out of HL Fund.

Cash Balance - Jan. 1, 2024	\$116,840.00
Jan. Receipts	\$45,951.58
Jan. Disbursements	<u>-\$48,983.30</u>
Cash Balance - Jan. 31, 2024	\$113,808.28

**BUILDING/SINKING FUND**

Purpose: To acquire new sites, improve existing buildings, all new building/construction expenses.

Funded by: Local Taxes, sale of property.

For RC: Previously used for HVAC projects, new propane tank HS, pays property taxes on farmland south of HS.

Would also be used for construction.

Cash Balance - Jan. 1, 2024	\$1,705,818.87
Jan. Receipts	\$105,732.25
Jan. Disbursements	<u>\$0.00</u>
Cash Balance - Jan. 31, 2024	\$1,811,551.12
Certificate of Deposit	<u>\$1,039,985.95</u>
Combined Balance - Jan. 31, 2024	\$2,851,537.07

**HIGH SCHOOL BOND FUND**

Purpose: Pay principal/interest on loans for new construction and additions.

Funded by: Local Taxes through a bond.

For RC: Used to pay interest/principal payts on 2009 HS Bond

Cash Balance - Jan. 1, 2024	\$381,982.90
Jan. Receipts	\$36,609.27
Jan. Disbursements	<u>\$0.00</u>
Cash Balance - Jan. 31, 2024	\$418,592.17

### DEPRECIATION FUND

Purpose: Pays to 'replace' not add. Fixing a roof, replacing a bus, upgrading systems.

Funded by: General Fund (GF) transfers at YE only with specific purpose identified.

For RC: In 8/2023, \$400,000.00 was transferred from the GF budget that was planned but not spent. This transfer was earmarked for truck/bus purchase, technology, safety upgrades and curric. materials.

Cash Balance - Jan. 1, 2024	\$288,775.35
Jan. Receipts	\$522.17
Jan. Disbursements	<u>\$0.00</u>
Cash Balance - Jan. 31, 2024	\$289,297.52
3 Certificates of Deposit	<u>\$1,648,433.90</u>
Combined Balance - Jan. 31, 2024	<u>\$1,937,731.42</u>

### QUALIFIED CAPITAL PURPOSE UNDERTAKING FUND

Purpose: Pays for removal of environmental hazards (mold, asbestos) and reduction/removal of accesibility barriers in school buildings.

Funded by: Local taxes via tax levy.

For RC: Not used at this time.

Cash Balance - Jan. 1, 2024	\$10,603.22
Jan. Receipts	\$8.63
Jan. Disbursements	<u>\$0.00</u>
Cash Balance - Jan. 31, 2024	\$10,611.85

### EMPLOYEE BENEFIT FUND - UNEMPLOYMENT

Purpose: Part of the General Fund. Can be used to pay unemployment, benefits, early retirement

Funded by: General Fund transfers at YE only with specific purpose identified.

For RC: In 8/2023 \$100,000.00 was transferred from the GF earmarked to pay Admin Benefit costs during the 23-24SY.

Cash Balance - Jan. 1, 2024	\$1,303.26
Jan. Receipts	\$0.55
Jan. Disbursements	<u>\$0.00</u>
Cash Balance - Jan. 31, 2024	\$1,303.81
3 Certificates of Deposit	<u>\$252,132.99</u>
Combined Balance - Jan. 31, 2024	<u>\$253,436.80</u>



**Raymond Central Public Schools**  
**Student Activities Fund Balances Jan. 2024**

<u>Activity Name</u>	<u>Beginning Balance</u>	<u>Revenues</u>	<u>Expenses</u>	<u>Balance</u>
After School Club	2,387.13	0.00	0.00	2,387.13
Annual	9,612.00	860.00	99.00	10,373.00
AP Funds	51,377.29	0.00	2,119.16	49,258.13
APEX	369.05	0.00	0.00	369.05
ART CLUB	284.68	500.00	0.00	784.68
Athletics	227,164.60	14,422.95	21,235.54	220,352.01
Band	77.16	17.89	0.00	95.05
Band Trip	10,669.76	0.00	0.00	10,669.76
Baseball	518.09	0.00	0.00	518.09
Boys BB	(1,029.05)	0.00	281.37	(1,310.42)
Ceresco Book Fair	91.22	0.00	0.00	91.22
Ceresco Field Trips	0.00	0.00	0.00	0.00
Ceresco Fundraising	2,233.57	0.00	0.00	2,233.57
Ceresco Pop	69.74	14.15	0.00	83.89
Cheerleaders	2,762.42	625.00	449.45	2,937.97
Choir	14,359.76	0.00	0.00	14,359.76
Class 2024	195.26	0.00	2,192.95	(1,997.69)
Class 2025	(1,215.26)	3,134.80	0.00	1,919.54
Class 2028	4,248.35	0.00	0.00	4,248.35
Class 2029 Field Trip Funds C	2,806.38	0.00	0.00	2,806.38
Class 2030 Field Trip Funds C	3,056.11	0.00	0.00	3,056.11
Class 2031 Field Trip Funds C	3,243.68	0.00	0.00	3,243.68
Class 2031 Field Trip Funds V	2,472.34	0.00	0.00	2,472.34
Class 2032 Field Trip Funds C	2,040.89	0.00	0.00	2,040.89
Class 2032 Field Trip Funds V	1,959.64	0.00	0.00	1,959.64
Class 2033 Field Trip Funds C	891.33	0.00	0.00	891.33
Class 2033 Field Trip Funds V	798.90	0.00	0.00	798.90
Class 2035 Cer	83.38	0.00	0.00	83.38
Class 2035 Val	592.96	0.00	0.00	592.96
Class of 2026	205.18	0.00	0.00	205.18
Class of 2027	3,613.18	0.00	0.00	3,613.18
Class of 2034 C	650.73	0.00	0.00	650.73
Class of 2034 V	387.59	0.00	0.00	387.59
College Access Grant	2,588.57	0.00	135.99	2,452.58
Computer	0.00	0.00	0.00	0.00
Cross Country	2,004.56	0.00	0.00	2,004.56
Culinary Snack Cart	1,390.69	0.00	0.00	1,390.69
DI	4,614.68	0.00	0.00	4,614.68
Drama Act	744.01	1,518.65	0.00	2,262.66
Drill Team	(998.52)	204.33	492.50	(1,286.69)
Elem Fines	555.04	0.00	0.00	555.04
Elem Fundraising	1,195.27	0.00	0.00	1,195.27
Elem PE	2,167.50	0.00	0.00	2,167.50
Elem Pictures/Yearbook	3,026.72	0.00	0.00	3,026.72

<u>Activity Name</u>	<u>Beginning Balance</u>	<u>Revenues</u>	<u>Expenses</u>	<u>Balance</u>
Elem Prof Development	4,797.94	0.00	0.00	4,797.94
Elem Student Council	483.85	0.00	0.00	483.85
FBLA Act	1,234.97	3,248.11	89.90	4,393.18
FFA Act	23,210.54	3,030.00	816.00	25,424.54
Fines	2,394.58	0.00	0.00	2,394.58
Football	2,788.40	0.00	0.00	2,788.40
Girls BB	(73.56)	22.50	0.00	(51.06)
Girls Wrestling	956.82	0.00	0.00	956.82
Golf Activity	1,068.91	0.00	0.00	1,068.91
HAL	59.66	0.00	0.00	59.66
Hot Lunch	347.63	0.00	0.00	347.63
HS Caring Shelves	4,594.06	0.00	656.20	3,937.86
HS Pop	1,996.01	142.05	111.57	2,026.49
HS Quiz Bowl	(219.11)	0.00	0.00	(219.11)
JH Boys BB	128.71	0.00	0.00	128.71
JH Football	382.84	0.00	0.00	382.84
JH Girls BB	809.70	0.00	0.00	809.70
JH Speech	1,516.45	0.00	0.00	1,516.45
JH Student Council	1,255.12	0.00	0.00	1,255.12
JH Track	604.57	0.00	0.00	604.57
JH Volleyball	1,339.13	0.00	0.00	1,339.13
JR Achievements	629.57	0.00	0.00	629.57
Kindness Acct	19,250.73	0.00	0.00	19,250.73
Library	1,866.23	36.00	0.00	1,902.23
Life Skills	2.41	0.00	0.00	2.41
Mock Trial	380.96	0.00	0.00	380.96
National Honor Society	649.27	0.00	0.00	649.27
Pre-Kindergarten	4,585.36	0.00	0.00	4,585.36
Professional Development	21,327.47	0.00	1,326.34	20,001.13
PTO	(0.00)	0.00	0.00	(0.00)
Rain Garden	459.50	0.00	0.00	459.50
RC Backpack	29,702.58	25.00	0.00	29,727.58
RC Blue Crew	(207.27)	0.00	0.00	(207.27)
RC Concessions	15,731.60	10,505.26	7,236.45	19,000.41
RC Foundation	24.00	0.00	0.00	24.00
Restitution	190.00	0.00	0.00	190.00
Score Vision	4,901.64	3,000.00	0.00	7,901.64
Service Fees (Activity Acct)	8,371.22	806.66	1,157.17	8,020.71
Skills USA	208.80	64.80	0.00	273.60
Social Justice	194.12	0.00	0.00	194.12
Softball	6,391.63	702.90	0.00	7,094.53
Spanish Club	3,023.04	110.00	372.99	2,760.05
Speech	9,756.23	49.00	96.29	9,708.94
Spring Musical	2,187.89	0.00	1,190.36	997.53
Staff Inservice	854.92	0.00	0.00	854.92
'Stang Gang Student Section	(0.01)	0.00	0.00	(0.01)
Student Council	7,310.16	92.79	30.00	7,372.95
Student Pop	772.80	417.49	0.00	1,190.29

<u>Activity Name</u>	<u>Beginning Balance</u>	<u>Revenues</u>	<u>Expenses</u>	<u>Balance</u>
Testing	4,365.23	0.00	0.00	4,365.23
Track	1,201.20	0.00	0.00	1,201.20
TShirt Press Acct	150.00	30.00	875.52	(695.52)
Val Book Fair	10,094.77	0.00	0.00	10,094.77
Val Field Trips	0.00	0.00	0.00	0.00
Val Fundraising	8,781.79	0.00	0.00	8,781.79
Val Pop	1,115.05	9.12	0.00	1,124.17
VolleyBall	10,662.16	0.00	0.00	10,662.16
Weight Room	4,000.00	0.00	0.00	4,000.00
Wrestling	3,429.77	0.00	0.00	3,429.77



**Raymond Central Public Schools**  
**Student Fees Fund Balances Jan. 2024**

<u>Activity Name</u>	<u>Beginning Balance</u>	<u>Receipts</u>	<u>Expenses</u>	<u>Balance</u>
Activity Pass	8,836.00	0.00	0.00	8,836.00
Ag-Ed Labs	2,137.39	0.00	0.00	2,137.39
Art Class	2,846.36	135.00	0.00	2,981.36
Chromebooks	6,398.37	210.00	359.80	6,248.57
Computer Science	249.99	0.00	0.00	249.99
Drama	28.28	0.00	0.00	28.28
FFA	100.00	0.00	0.00	100.00
Foods Class	2,624.35	195.00	253.98	2,565.37
Service Fees (Student Fees)	2,085.78	42.92	10.49	2,118.21
Skills USA	1,510.00	0.00	0.00	1,510.00
Speech	175.00	0.00	0.00	175.00
Sports Fees	17,965.22	80.00	0.00	18,045.22
Tech Ed	1,542.28	0.00	470.83	1,071.45

Monthly Bills



# Raymond Central Public Schools

## Bills Paid January 2024

### General Fund - Report of Bills Paid January 2024

<u>Check Date</u>	<u>Vendor Name</u>	<u>Description</u>	<u>Amount</u>
1/19/2024	RCPS Dist. #161	January Payroll	716,244.40
1/25/2024	InCharge Energy, Inc	Electric Bus Charger System	21,583.00
1/11/2024	MCS	Custodial Supplies, all Locations	10,980.81
1/16/2024	Otte Oil & Propane Inc.	Propane HS	10,881.51
1/11/2024	Norris Public Power	Electricity HS	9,751.24
1/11/2024	Fox, Kindra	SPED Services OT 10/14/23 - 12/21/23	5,853.30
1/16/2024	US Bank	Shed Bldg Materials	5,695.83
1/25/2024	NE Association of School Boards	Annual Membership Dues	5,027.00
1/11/2024	SPARQDATA Solutions	Sparq Mtg Yrly Subscrip/Software	4,712.00
1/26/2024	Sentry Electric Inc.	Exterior Lights& Power-Shed HSPay#2	4,700.00
1/19/2024	Alternative Service & Repair	Bus 21 Replace Breads	4,697.86
1/11/2024	Pine Cove Consulting	Managed Tech Service Jan 2024	4,500.00
1/25/2024	SCOREVISION, LLC	Split Expense of Shot Clock	3,750.00
1/11/2024	Otte Oil & Propane Inc.	Propane HS	3,356.64
1/11/2024	NE Rural Community School Assoc	2nd half + expenses Supt Search Fee	3,271.02
1/16/2024	Electronic Contracting Company	Fire Alarm Inspections All locations	3,200.00
1/11/2024	Shepard Gym Floors	Gym Floor Refinishing HS	3,025.00
1/11/2024	Institute for Multi Sensory Educat'n	Morphology training	3,000.00
1/16/2024	Macintosh Concrete Inc.	Pad- Discuss Competition	2,850.00
1/25/2024	Computer Hardware	Macbook for Managing ipads	2,499.95
1/11/2024	Butler Public Power District	Electricity V	2,432.59
1/16/2024	Hands of Heartland	SPED Transitional Program Dec	2,411.66
1/11/2024	Access Systems, Inc	Copiers- Monthly	2,357.52
1/11/2024	Omaha Public Power Dist	Electricity C	2,349.33
1/19/2024	Brooke L. Cheleen	Dect 2023 SPED Physical Therapy	1,786.97
1/16/2024	US Bank	Maintenance Supplies C	1,686.72
1/19/2024	Johnson, Lynn	Mileage & Parking Reimbursement	1,662.33
1/25/2024	Computer Hardware	Prototype/Test Laptop-Future Tchr Use	1,649.95
1/19/2024	Trane US Inc	Repairs HVAC	1,597.00
1/11/2024	Perry Guthery Haase & Gessford	Legal Services	1,545.60
1/16/2024	US Bank	Musical - Llicensing Fee	1,508.64
1/11/2024	Grunwald Mechanical Contractors	HS Boiler Repair	1,485.00
1/19/2024	Haxton, Richard	Snow Removal 1/9,1/12,1/14,1/18/24 V	1,400.00
1/16/2024	NE Association of School Boards	Supt- Evaluation, BOE Retreat	1,087.99
1/19/2024	VIRCO	2 Tchr Desk Chairs	1,086.40
1/11/2024	Kajeet Inc	Renewal for 5 district Hotspots	1,027.07
1/19/2024	Nebraska Dept Of Revenue	Motor Fuels Tax	841.00
1/11/2024	Kiner Supply Company	Building Repair Supplies -Plumbing HS	806.11
1/11/2024	Waste Connections Co	Garbage HS, V	670.62
1/19/2024	Access Systems, Inc	Overage Charges Printers 4th Quarter	663.42
1/16/2024	Metzger, Joseph	Snow Removal C 1/9/24, 1/14/24	600.00
1/16/2024	Ron's Rolloffs Inc.	Dumpster/Dump Fees HS	583.45
1/19/2024	Alternative Service & Repair	Bus 17A Oil/Filter	582.40
1/11/2024	Windstream	Phone HS, Fax	571.67
1/25/2024	Advanced Auto Glass	New Windshield& Side Window Bus 19A	550.00
1/19/2024	Menards Lincoln	Antifreeze-Buses; Shelves-Art Room HS	488.42
1/16/2024	US Bank	Amazon-Storage Unit for PK3	463.46
1/11/2024	Jaymar Business Forms	Stud. Activities Fund Checkstock-Reorder	448.26
1/16/2024	US Bank	Clock HS	435.62
1/11/2024	Home Depot Pro	Custodial Supplies HS	433.97
1/11/2024	Hydro Optimization/Automation	Well Pump Service Call HS	416.50
1/26/2024	Kiner Supply Company	Building Repair Supplies -Plumbing HS	416.44
1/16/2024	US Bank	Vet Science Class Supplies	383.92
1/16/2024	US Bank	Casio Calculators Math Dept	328.16
1/11/2024	Village Of Ceresco	Utilities C	306.49
1/18/2024	Doane University	Entry Fees for Speech Invite 1/6	278.00
1/19/2024	A 1st Rate Pumping & Potty	Clean out Mud Pit - Bus Barn	265.20
1/16/2024	WeatherCraft Co. Of Lincoln	Patched Seam Intersections	243.52
1/11/2024	Priefert, Tom	Parent Mileage Reimb Dec 2023	226.96

<u>Check Date</u>	<u>Vendor Name</u>	<u>Description</u>	<u>Amount</u>
1/16/2024	US Bank	5 point harness-SpEd Van	223.85
1/25/2024	Intermedia.net, INC	Phone Service	219.55
1/11/2024	Intermedia.net, INC	Phone Service	219.48
1/11/2024	Oak Valley Lumber Co	Building Maint Supplies	218.86
1/19/2024	Quest Diagnostics	3rd Party Drug Testing	213.50
1/11/2024	Village Of Valparaiso	Utilities V	206.12
1/11/2024	Donald R. Prentice	Extermination Service	205.00
1/19/2024	O' Reilly Auto Parts	Oil for Buses	201.15
1/17/2024	Jackson Services Inc.	Mats/Mops	198.49
1/25/2024	Column Software PBC	Waverly Newspaper Publication	195.81
1/25/2024	Column Software PBC	Waverly Newspaper Publication	187.02
1/11/2024	Menards Lincoln	Building Maint C, HS, V	180.15
1/25/2024	Truck Center Companies	Mirror for Bus	173.99
1/16/2024	US Bank	CarveWheel, Venting Adapters&Hoses Tech Ed	168.78
1/5/2024	Doane University	Doane Honor Choir Registration Fee	150.00
1/16/2024	US Bank	Cornell University Vet Science Curriculum	150.00
1/25/2024	Prorok, Allison	Mileage Reimb ESU Prek Training	148.03
1/11/2024	School Specialty	SPED Supplies V	142.84
1/25/2024	Crees, Jennifer	Mileage Reimb Health Tech 12/23, 1/24	142.41
1/5/2024	Waverly High School	JV Wrestling Tourney 1/6	130.00
1/18/2024	Lincoln Southwest HS	Speech Entry Fees 1/20	128.00
1/3/2024	Wood River HS	Boys wrestling Dual Tourney Fee	125.00
1/11/2024	Trenhaile, Clair	SLP Reimb Mileage Dec 2023	124.91
1/3/2024	High Plains Public Schools	Girls Wr. Invite 1/4	120.00
1/16/2024	NE State Fire Marshal	Annual Elevator Inspection V	120.00
1/16/2024	US Bank	One year digital subscription LJS	120.00
1/11/2024	Wahoo-Wav.-Ashl. News	Publications	117.31
1/19/2024	Nebraska/Central Equipment, Inc	Bus Parts	115.19
1/16/2024	US Bank	SPED Supplies HS	110.68
1/19/2024	Johnson, Lynn	Reimb Food/ BOE Conf Omaha	110.60
1/3/2024	Central City HS	Boys Invite Entry Fee	110.00
1/11/2024	Matheson Tri-Gas Inc.	Welding Tank Rental	104.77
1/16/2024	US Bank	SPED Supplies C	104.53
1/16/2024	US Bank	Classroom Supplies PreK3	96.98
1/19/2024	Menards Lincoln	2 Electric Heaters- PreK3 Bathrooms	89.98
1/11/2024	Central Comm College	Training CTE/ JS	85.00
1/18/2024	Ralston Public School	Dance Team Entry Fee	80.00
1/16/2024	US Bank	Guidance Supplies 6th	73.83
1/11/2024	One Source	Employee Background Checks	71.00
1/16/2024	US Bank	SPED Director Office Supplies	70.78
1/25/2024	Column Software PBC	Waverly Newspaper Publication	65.35
1/11/2024	Amanda Ehlers	Reimb Mileage Dec	62.23
1/18/2024	Atteberry, Christopher	Speech Judge 1/20	60.00
1/18/2024	Cadotte, Grace	Speech Judge 1/20	60.00
1/18/2024	Jorgensen, Emma	Speech Judge 1/20	60.00
1/18/2024	McFarling, Andrea	1/6 speech judge	60.00
1/18/2024	Reeves, Beth	1/6 speech judge	60.00
1/11/2024	Ducts On Demand	Galvanized Duct	55.00
1/16/2024	US Bank	2nd Grade Class Supplies V	50.88
1/11/2024	ASI	Payflex Admin Fees	50.00
1/16/2024	US Bank	Foods/ FCS	45.72
1/16/2024	US Bank	Supplies Office V	42.99
1/11/2024	Jostens	2 Diplomas 12/2023	41.35
1/19/2024	Jones Bank	Safe Deposit Box Rental 2023	40.00
1/25/2024	Maly, Linda	Title1 Services-St Johns-Weston Jan 2024	37.50
1/16/2024	US Bank	Library Supplies C	35.99
1/16/2024	US Bank	STEM Supplies V,C	32.20
1/11/2024	Becky Studebaker	Reimb. Electricity-Bus Month 2 of 4	30.00
1/11/2024	Leann Wiese	Reimb. Electricity-Bus Month 2 of 4	30.00
1/11/2024	Matt Smith	Reimb. Electricity-Bus Month 2 of 4	30.00
1/11/2024	Suchy, Maggie	Reimb Electricity/Bus Month 2 of 4	30.00
1/16/2024	US Bank	Ethernet cable for Senior pic board	29.99
1/11/2024	Tvrdy, Laura	Concession supplies	27.98
1/25/2024	Column Software PBC	Waverly Newspaper Publication	26.05
1/11/2024	Dietze Music	Instrumental - Valve and Swab	23.00

<u>Check Date</u>	<u>Vendor Name</u>	<u>Description</u>	<u>Amount</u>
1/11/2024	Tvrdy's One Stop	Tire Repair	22.95
1/11/2024	RCHS Girls Basketball	Donated Activity Work Pay	22.50
1/16/2024	US Bank	Nebraska Flag	21.99
1/16/2024	US Bank	Car Seat Harness for PreK Bus	15.48
1/25/2024	Column Software PBC	Waverly Newspaper Publication	14.55
1/11/2024	Woods, Carrie	Mileage Reimb Dec	13.10

**Hot Lunch Fund - Report of Bills Paid January 2024**

<u>Check Date</u>	<u>Vendor Name</u>	<u>Description</u>	<u>Amount</u>
1/19/2024	RCPS Dist 161	Hot Lunch Staff Jan. Payroll	22,128.34
1/17/2024	Cash-Wa Distributing	Food / Supplies	8,478.02
1/17/2024	Sysco Lincoln	Food and Supply	7,929.42
1/16/2024	US Bank	Fresh Meat. Local Butcher	3,838.52
1/17/2024	Hiland Dairy	Milk	2,376.36
1/11/2024	MCS	Forks and spoons	1,567.81
1/25/2024	Summit Fire Protection	Inspect Fire Hoods Kitchens HS, C,V	1,029.00
1/16/2024	US Bank	Food C/V, Cart/Table for Kitchen - V	721.31
1/9/2024	RevTrak	Hot Lunch Fund Revtrak Fees	420.77
1/11/2024	SICO America, Inc	Replacement Seats Lunchroom Tables	308.00
1/17/2024	Jackson Services Inc.	Kitchen Cleaning Cloth	132.35
1/11/2024	RCPS Student Fees	Transfer Balance Jurgens-Miller from HL	53.40

**Building/Sinking Fund - Report of Bills Paid January 2024**

<u>Check Date</u>	<u>Vendor Name</u>	<u>Description</u>	<u>Amount</u>
1/26/2024	Lierman Excavation Co. Inc	Grading SB/BB Field	43,300.00



## Raymond Central Public Schools Student Activities Fund Checks Jan. 2024

<u>Activity Name</u>	<u>Date</u>	<u>Vendor</u>	<u>Description</u>	<u>Amount</u>
Athletics	01/25/2024	SCOREVISION, LLC	50% of shot clock cost	7,500.00
Athletics	01/25/2024	CMC Neptune LLC	Game Time 2024-2025 Subscription	2,700.00
Class 2024	01/25/2024	Jostens	Class 2024-Grad.Caps/Robes	2,192.95
Professional Development	01/15/2024	US Bank	Professional Development	1,284.34
Spring Musical	01/15/2024	US Bank	Musical licensing	1,190.36
Service Fees (Activity Acct)	01/11/2024	RCPS General Fund	Transfer PreK Tuition Payts	1,080.00
TShirt Press Acct	01/16/2024	US Bank	Shirt Order	875.52
Athletics	01/16/2024	Element ninety three	Senior banners and team photos	720.00
RC Concessions	01/31/2024	RC Softball	Profit from 1/26 conc.	702.90
RC Concessions	01/19/2024	Pepsi Cola Of Lincoln	pop/water for concessions	665.60
RC Concessions	01/31/2024	RCWC	Profit from 1/27 conc.	657.67
HS Caring Shelves	01/15/2024	US Bank	Cmas Food and Gifts	656.20
RC Concessions	01/18/2024	Super C	Pizzas for concessions	630.00
RC Concessions	01/19/2024	Super C	Pizzas Restock	540.00
AP Funds	01/11/2024	University of Nebraska Kearney	Rachel Bos scholarship Dual Credit	500.00
AP Funds	01/19/2024	Northwest Missouri State University	Madysen Ayres Dual Credit Scholarsh	500.00
Drill Team	01/11/2024	Image Market	tees for camp	499.50
RC Concessions	01/31/2024	RC Athletics	Profit from 1/26 conc.	468.60
RC Concessions	01/31/2024	RC Athletics	Profit from 1/27 conc.	438.45
RC Concessions	01/23/2024	Raymond Central One Act Play	profit from 1/5 conc.	397.65
FFA Act	01/25/2024	Hailee, Nelson	Pumpkins	375.00
Spanish Club	01/05/2024	Karel, Josh	Reimb Spanish Club Dinner	372.99
Athletics	01/24/2024	Hunt, Rusty(Donald)	Boys V Wr. Official 1/27	350.00
Athletics	01/24/2024	Hunt, Nathan	Boys V Wr. Official 1/27	350.00
Athletics	01/24/2024	Woolsey, Brian	Boys V Wr. Official 1/27	350.00
Athletics	01/24/2024	Ostrom, Jace	JVB/GV Wr. Official 1/26	350.00
Athletics	01/24/2024	Berner, Todd	JVB/GV Wr. Official 1/26	350.00
Athletics	01/24/2024	Allen, Wren	JVB/GV Wr. Official 1/26	350.00
Athletics	01/24/2024	Jacobsen, Kevin	Boys V Wr. Official 1/27	350.00
Athletics	01/24/2024	Hunt, Rusty(Donald)	JVB/GV Wr. Official 1/26	350.00
Athletics	01/26/2024	Ostrom, Joel	JVB/GV Wr. Official 1/26	350.00
Athletics	01/26/2024	Zimmerman, Jeff	JVB/GV Wr. Official 1/26	350.00
RC Concessions	01/24/2024	RCPS FBLA	Profit from 1/19 conc	349.80
Cheerleaders	01/15/2024	US Bank	Cheerleaders	343.20
Athletics	01/19/2024	Raymono`s Pizza	Wrestling Hospitality Room 12/8	323.85
Athletics	01/24/2024	NCC @ Logan View	gate profit from ncc gbb 1st round	314.00
RC Concessions	01/15/2024	US Bank	RC Concessions restock	307.66
Athletics	01/31/2024	Simpson, Amanda	Athletic Trainer for 1/26 wr. meet	280.00
Athletics	01/31/2024	Townsend, Ryan	Athletic Trainer for 1/27 wr. meet	280.00
RC Concessions	01/23/2024	RC Athletics	profit from 1/5 conc.	265.10
Athletics	01/16/2024	Kratochvil, Ryan	Girls Wrestling Triangular 1/16	250.00
Athletics	01/18/2024	Scheel, Ken	Reserve BB Tourney Official 1/20	240.00
Athletics	01/18/2024	Kreikemeier, Isaac	Reserve BB Tourney Official 1/20	240.00
Athletics	01/18/2024	Tobin, Reinwald	Reserve BB Tourney Official 1/20	240.00
Athletics	01/18/2024	Libal, Jason	Reserve BB Tourney Official 1/20	240.00
RC Concessions	01/24/2024	RC Athletics	Profit from 1/19 conc	233.20
RC Concessions	01/31/2024	RCWC	Profit from 1/25 conc.	210.75
Boys BB	01/11/2024	Hauff Mid America Sports	Boys Bball coach apparel	202.99
Athletics	01/31/2024	Norris High School	Boys Wr. Entry Fee 2/2	200.00
RC Concessions	01/31/2024	RCPS FBLA	Profit from 1/29 conc.	194.17
RC Concessions	01/16/2024	Del Gould Meat Co., Inc	Hot dogs for concessions	192.00
Athletics	01/18/2024	Louisville High School	Girls Wrestling Invite 1/19	185.00
FFA Act	01/15/2024	US Bank	Gingerbread Houses	182.07
Athletics	01/18/2024	Hunt, Rusty(Donald)	Boys Wr. Dual 1/18	175.00
FFA Act	01/16/2024	Howells-Dodge FFA	LDE Meals	165.00
AP Funds	01/11/2024	Osmera, Nancy	Book Scholarship	152.27
Athletics	01/03/2024	Godtel, Shane	Varsity bball official 1/5	150.00
Athletics	01/03/2024	Bracht, Jeff	Varsity bball official 1/5	150.00
Athletics	01/03/2024	Godtel, Jakob	Varsity bball official 1/5	150.00
Athletics	01/18/2024	Risueno, Carlos	Varsity BB Official 1/19	150.00

<u>Activity Name</u>	<u>Date</u>	<u>Vendor</u>	<u>Description</u>	<u>Amount</u>
Athletics	01/18/2024	McCormack, Chris	Varsity BB Official 1/19	150.00
Athletics	01/18/2024	Larson, Mike	Varsity BB Official 1/19	150.00
Athletics	01/24/2024	Gore, Coleman	Track Wrestling 1/27	150.00
Athletics	01/24/2024	Gore, Coleman	Track Wrestling 1/26	150.00
Athletics	01/25/2024	Westring, Derek	Varsity BB Official 2/2	150.00
Athletics	01/25/2024	Terry, Graver	Varsity BB Official 1/30	150.00
Athletics	01/25/2024	Krivohlavek, Seth	Varsity BB Official 1/30	150.00
Athletics	01/25/2024	Krivohlavek, Bo	Varsity BB Official 1/30	150.00
Athletics	01/25/2024	Heir, Tod	Varsity BB Official 2/2	150.00
Athletics	01/25/2024	Leitschuk, David	Varsity BB Official 2/2	150.00
RC Concessions	01/31/2024	RC Athletics	Profit from 1/25 conc.	140.50
AP Funds	01/11/2024	William R. Lange	Book Scholarship -Sarah	139.31
RC Concessions	01/24/2024	Class of 2025	Profit from 1/20 conc	136.80
College Access Grant	01/16/2024	US Bank	Stats Book	135.99
RC Concessions	01/11/2024	Sysco Lincoln	concessions supplies	134.88
RC Concessions	01/11/2024	Tvrdy, Laura	Reimb Concession supplies	134.40
RC Concessions	01/31/2024	RC Athletics	Profit from 1/29 conc.	129.45
Athletics	01/18/2024	Weeping Water HS	Girls Wr. Invite 1/20	120.00
Athletics	01/29/2024	Benes, Adam	JH Official 1/29	120.00
Athletics	01/29/2024	Gerlach, Brenden	JH Official 1/29	120.00
HS Pop	01/15/2024	US Bank	Memorial Plant/Wedding/Baby-Staff	111.57
Cheerleaders	01/15/2024	US Bank	Power Music Cheer	106.25
Athletics	01/25/2024	Norfolk Catholic Schools	Girls Wr. Entry Fee	100.00
Annual	01/16/2024	US Bank	yearly update for smore newsletter	99.00
Speech	01/11/2024	Super C	Pizza for Speech Christmas party	96.29
AP Funds	01/11/2024	Svoboda, Olivia	Book scholarship	95.35
RC Concessions	01/24/2024	RC Athletics	Profit from 1/20 conc	91.20
AP Funds	01/11/2024	Fisher, Katie	Book Scholarship	90.79
AP Funds	01/11/2024	Faimon, Payton	Book Scholarship	90.79
RC Concessions	01/16/2024	Super C	Frozen Pizza Restock	90.00
FBLA Act	01/16/2024	US Bank	AnnoDeel 100pcs Red Heart Foil	89.90
AP Funds	01/11/2024	White, Jeff	Book Scholarship	87.99
AP Funds	01/16/2024	Ceja, Ariana	Book Scholarship	84.81
AP Funds	01/16/2024	Novoselov, Sophia	Book Scholarship	84.38
RC Concessions	01/24/2024	RCWC	Profit from 1/16 conc.	83.85
RC Concessions	01/24/2024	RC Dance Team	profit from 1/22 conc.	80.33
Athletics	01/19/2024	Weeping Water HS	JV Wrestling Invite 1/22	80.00
Athletics	01/29/2024	Kreikemeier, Isaac	2/1 JH official	80.00
AP Funds	01/11/2024	Lockman, Taylor	Book Scholarship	79.90
Boys BB	01/11/2024	Hauff Mid America Sports	Boys BB	78.38
Service Fees (Activity Acct)	01/09/2024	RevTrak	Service Fees (Activity Acct)	77.17
AP Funds	01/16/2024	Leise, Madison	Book Scholarship	73.45
RC Concessions	01/23/2024	RC Skills USA	Profit from 1/4 conc.	64.80
FFA Act	01/19/2024	Raymono`s Pizza	Pizza	63.93
RC Concessions	01/25/2024	Sysco Lincoln	concessions supplies	63.49
RC Concessions	01/18/2024	Sysco Lincoln	popcorn oil	60.54
Athletics	01/03/2024	Keeney, Paul	Reserve Bball Official 1/4	60.00
Athletics	01/03/2024	Keeney, Triston	Reserve Bball Official 1/4	60.00
Athletics	01/03/2024	Scheel, Ken	JV Bball Official 1/5	60.00
Athletics	01/05/2024	Kreikemeier, Isaac	JVBB Official 1/5	60.00
Athletics	01/18/2024	Smith, Ken	JV BB Official 1/19	60.00
Athletics	01/18/2024	Benes, Adam	JV BB Official 1/19	60.00
Athletics	01/18/2024	Steiger, Larry	JV BB Official 1/19	60.00
Athletics	01/18/2024	Piening, Scott	JV BB Official 1/19	60.00
Athletics	01/29/2024	Scheel, Ken	JV Official 1/30	60.00
Athletics	01/29/2024	Keeney, Paul	JV Official 1/30	60.00
Athletics	01/29/2024	Gerlach, Brenden	JV Official 1/30	60.00
Athletics	01/29/2024	Wall, Jerry	JV Official 1/30	60.00
Athletics	01/31/2024	Scheel, Ken	JV BB Official 2/2	60.00
Athletics	01/31/2024	Tjaden, Landon	JV BB Official 2/2	60.00
Athletics	01/31/2024	Ali, Asim	JV BB Official 2/2	60.00
Athletics	01/31/2024	Aufdenkamp, Charles	JV BB Official 2/2	60.00
Athletics	01/15/2024	US Bank	wrestling hospitality room	57.69
RC Concessions	01/23/2024	RC Athletics	Profit from 1/16 conc.	55.90
Athletics	01/29/2024	Steiger, Larry	Reserve Official 1/29	55.00

<u>Activity Name</u>	<u>Date</u>	<u>Vendor</u>	<u>Description</u>	<u>Amount</u>
Athletics	01/29/2024	Wall, Jerry	Reserve Official 1/29	55.00
AP Funds	01/11/2024	Donahue, Erika	Book Scholarship	55.00
AP Funds	01/11/2024	Wolfe, Carlee	Book Scholarship	54.45
RC Concessions	01/24/2024	RC Athletics	profit from 1/22 conc.	53.55
RC Concessions	01/23/2024	RC Athletics	Profit from 1/4 conc.	43.20
Professional Development	01/25/2024	RC FFA	Meat/cheese for Prof Dev Meal	42.00
RC Concessions	01/15/2024	US Bank	popcorn oil	32.96
AP Funds	01/16/2024	Bos, Leslie	Book Scholarship	30.67
FFA Act	01/25/2024	NAEA District 2	Floriculture Contest	30.00
Student Council	01/16/2024	US Bank	Student Council Supplies	30.00
Drill Team	01/16/2024	US Bank	Drill Team -Activities Fund	28.00



**Raymond Central Public Schools**  
**Student Fees Fund Checks Jan. 2024**

<u>Activity Name</u>	<u>Date</u>	<u>Vendor</u>	<u>Description</u>	<u>Amount</u>
F&CS Student Fees/Supplies	01/15/2024	US Bank	Groceries	253.98
Tech Educ Student Fees	01/19/2024	Menards Lincoln	Finishes, screws, stains, gloves	470.83
Chromebook Student Fees	01/11/2024	Edu-Parts	Chromebook Screens	359.80
Service Fees (Student Fees)	01/09/2024	RevTrak	Service Fees (Student Fees)	10.49



**General Policy Statement**

The Board of Education delegates to the Superintendent the responsibility of maintaining the program of instruction and extracurricular activities.

The instructional program and extracurricular activities shall meet the accredited school system standard of the State Board of Education through the Nebraska Department of Education, Federal regulations, Nebraska School Activities Association regulations and the policies of the Board of Education.

The professional staff is responsible for the development of educational and activities programs which meet the objectives of Raymond Central Public Schools.

Date of Adoption: May 18, 2009

**The Program of Instruction**

The minimum program of instruction in the schools shall be that prescribed by the statutes. The statutory curriculum may be augmented and extended to provide for the educational needs of individual pupils and differing areas in the School District.

The District shall educate staff and students about the harms of copyright privacy.

Legal Reference: Rule 10; ESSA

Date of Adoption: May 18, 2009

Date of Revision: July 13, 2016

**Classroom Environment**

At all times, teachers are expected to organize, maintain and ensure that their classroom is in a safe, orderly and clean condition for student learning. Classrooms should be free from distractions (such as inappropriate or unprofessional posters or other displays) and other apparatus that may cause student health problems (such as essential oils and/or essential oil diffusers). Teachers who are uncertain as to whether their classroom meets this requirement are encouraged to consult with their building principal in a proactive manner.

Date of Adoption: July 15, 2020

**Emergencies**

All employees of the school system are responsible for promoting the safety of students.

Procedures for fire, civil defense, and other emergencies shall be maintained.

Legal Reference: Neb. Rev. Stat. § 79-706

Date of Adoption: May 18, 2009

**Emergency Dismissal or Cancellation**

Except for those dates designated on the school calendar, school shall not be dismissed or canceled except by action of the Board of Education or in emergency situations as determined by the Superintendent.

Date of Adoption: May 18, 2009

**Ceremonies, Observances, and the Pledge of Allegiance**

Appropriate patriotic exercises suitable to the occasion shall be held under the direction of the Superintendent on George Washington's birthday, Abraham Lincoln's birthday, Dr. Martin Luther King, Jr.'s birthday, Native American Heritage Day, Constitution Day, Memorial Day, Veterans Day, and Thanksgiving Day, or on the day or week preceding or following such holiday, if the school is in session. In addition, appropriate exercises may be held for Flag Day and State Fire Day.

The flags of the United States of America and the State of Nebraska shall be prominently displayed on the school grounds on each day such school is in session. All flag displays shall be in accordance with the standards prescribed for the display of the flag of the United States of America.

Each of the District's schools shall establish a period of time during the school day, when a majority of the students are scheduled to be present, during which time students will be led in the recitation of the Pledge of Allegiance in the presence of the flag of the United States of America. Student participation in the recitation of the Pledge of Allegiance shall be voluntary. Students not participating in the recitation of the Pledge of Allegiance shall be permitted to silently stand or remain seated but shall be required to respect the rights of those students electing to participate.

Legal Reference: Neb. Rev. Stat. §§ 79-705; 79-707, 79-708, 79-724; and NDE Rule 10  
70 Federal Register 55507 (Constitution Day)

Date of Adoption: May 18, 2009  
Date of Revision: June 10, 2020

**Safe Schools Policy**

It is the mission of Raymond Central Public Schools to provide a safe, secure, drug-free and welcoming environment for all students, staff and community members. The administration is authorized and directed to adopt such regulations and take such actions as determined appropriate by the board of education to advance the mission of providing safe schools. Such regulations and actions may include, but not be limited to, school security measures, such as use of metal detectors, surveillance, searches and seizures, and security officers, as well as staff training and student educational programs.

Date of Adoption: May 18, 2009

**Curriculum - Development and Adoption**

All major program adoptions and/or major course revisions shall be subject to the approval of the Board of Education.

Major program adoptions and/or major course revisions may be proposed by district-wide curriculum and/or building curriculum committees and approved, rejected or revised and approved by the Superintendent before being submitted to the Board of Education for final approval.

Date of Adoption: May 18, 2009

## Curriculum - Assessments

### 1. State Assessments.

Raymond Central Public Schools has adopted an assessment plan and has aligned the curriculum with the state approved content standards. The assessment plan includes a schedule and procedures for assessing success in achieving state standards.

Teachers are to clearly articulate the learning targets and align instruction to the learning targets within each of the content standards. Teachers are to give students instruction on the content prior to students being assessed on each content standard in order to provide learning opportunities for all students.

The assessments are to be conducted in accordance with the assessment plan schedule. Teachers are to conduct the assessments in a manner that assures it accurately assesses whether or not students are meeting the targets outlined by the content standards.

Assessment results are to be reported by the teachers in the manner and within the time directed by the administration or designee. The assessment data is to be used to meet state standards, to provide students and parents with information about student progress, to enhance school improvement planning, and to improve instruction. The assessment data is to be evaluated by teachers to monitor student learning and to improve instruction or terminate ineffective teaching practices to ensure students are being given the opportunity to meet the standards.

### 2. Achieving Valid Assessments.

Educators are responsible for maintaining the integrity of the assessments to ensure that assessments provide a valid measure of student progress and accomplishments. Educators are not to engage in any practice that may result in assessment results that do not reflect student learning, knowledge, skills or abilities in the area assessed.

For purposes of this policy, student assessments include both “standardized assessments” (including state assessments, norm referenced tests, and evaluations conducted for special education eligibility) and “coursework assessments” (e.g., classroom tests, quizzes, and other evaluative tools used to assign grades).

The following specific assessment expectations and rules apply:

- a. Integrity of the Assessment Instrument. The integrity of the assessment instrument is to be maintained.
  - i. Standardized Assessments. Standardized assessment instruments are not to be made available to students at any time before the student takes the assessment. The assessment instrument is to be maintained in a secure manner.
  - ii. Coursework Assessments. Coursework assessment instruments are to be periodically modified to keep the assessments current and prevent students from effectively using “test banks.” For coursework assessments that are given on a repeat basis to students at different times (e.g., a test that is given to students throughout the school day), the educator is to remind students to not share the content of the assessment with students who will be taking the assessment later.
- b. Teaching for Success on Assessments.

It is appropriate for educators to prepare students to do well on assessments. This is to be accomplished in a manner that assures the assessment accurately reflects the student's knowledge, and not simply test preparation.

- i. Teach the Content. Educators are to prepare students to do well on assessments by teaching the subject content. Educators are not to “teach to the test” by teaching based solely on the content of the assessment. The content is to be taught to the students over an appropriate amount of time prior to the assessment. “Cramming” assessment content just before the assessment is to be taken is not appropriate. Review of content previously taught is appropriate.
  - ii. Practice Tests. Educators are to prepare students by teaching test taking skills independent of the subject matter being assessed. Educators are not to conduct reviews (drills) using earlier (no longer published) versions of the same test, using alternate (parallel) forms of the same published test, or using actual items from the current form of a standardized test that will be administered to students. Educators are not to conduct reviews (drills) using items of identical format (for example, multiple choice) to the exclusion of other formats.
- c. Conditions for Successful Assessments.
- i. Communications. Educators are to communicate to students and parents when assessments will be administered, the purpose of the assessment and how the assessment results will be used. Educators are to motivate students to do their best on assessments. Educators are to read and be familiar with assessment administration directions in advance and communicate the rules to students accurately and clearly.
  - ii. Climate. Educators are to have sufficient assessment materials available (e.g., No. 2 pencils, if needed). The classroom is to be arranged to allow comfortable seating. Distractions are to be eliminated. Educators in nearby classrooms are to be informed that the assessment is to be administered so noises from neighboring classrooms are kept at a minimum. Activities or arrangements are to be made for students who finish early so such students do not cause a distraction to other students still taking the assessment.
  - iii. Security. Educators are to monitor students while administering assessments to ensure students are complying with standards of academic integrity. Students who violate standards of academic integrity are to be reported to the administration.
- d. Full Participation. Educators are to make efforts to have all eligible students take the assessments. The educator should develop a list of students who will be exempted from assessment and the reason for the exemption and submit the list for review and approval by the Principal.
- e. Assistance During Assessments.
- i. Standardized Assessments. Educators are not to provide assistance to students while a standardized assessment is being administered except as provided for in a student's 504 Plan or IEP. This includes giving “hints,” giving extra time, reading the tests to students or defining or pronouncing words for students, allowing students access to instructional material related to the content of the assessment (e.g., displaying a map during a social studies assessment) or allowing students access to mechanical aids (e.g., calculators).
  - ii. Coursework Assessments. For coursework assessments, students may be allowed access to instructional materials or mechanical aids only when all students being given the assessment

are given the aids and use of the aids does not hinder the students from learning the content of the lesson.

- f. Student Answers. Assessments are to reflect the students' work as submitted by the students. During the assessments, educators are to monitor students to make sure directions are being followed (e.g., students are using a No. 2 pencil on all "bubble" sheet assessments and completely erase mistaken answers and extra marks on "bubble" sheet assessments). Educators are not to change answers on a student's assessment sheet or otherwise participate in the submission of false or misleading assessment results.

All employees are to adhere to the Nebraska Student-Centered Assessment System (NSCAS) Security Procedures and report breaches in security to Superintendent or the Superintendent's assessment designee for report to the Nebraska Department of Education. Professionalism, common sense, and practical procedures provide the framework for testing ethics.

Violations of the rules and expectations set forth in this policy will be considered to be a breach of the District's standard of ethics and may result in disciplinary consequences. Educators are to report suspected violations of the expectation to the administration. The administration is to investigate and appropriately respond to violations of the expectations.

Legal Reference: NDE Rule 10.05; NDE Rule 27.004.02H and 004.03D

Date of Adoption: August 15, 2011

Date of Revision: June 10, 2019

**Assessments - Academic Content Standards**

The Board of Education adopts the academic content standards of the State Board of Education (“State Board”). The adoption of the academic content standards includes the:

Language Arts standards that were adopted by the State Board in September, 2021;  
Mathematics standards that were approved by the State Board in September, 2022;  
Science standards that were adopted by the State Board in September, 2017; and  
Social Studies standards that were adopted by the State Board in November, 2019.

Unless other action is taken, the Board of Education adopts the standards of the State Board as such standards are subsequently adopted or amended by the State Board.

The administration shall be responsible for implementing assessments on the state standards in accordance with the procedures established by the State Board and the Department of Education, including conducting assessments in the same subject areas and the same grade levels as established in the state standards, and the reporting of scores and subscores.

This policy does not supersede the existing standards adopted by the Board of Education except as set forth herein.

Legal Reference: Neb. Rev. Stat. §§ 79-760 to 79-760.05

Date of Adoption: July 15, 2013

Date of Revision: July 12, 2023

**Experimental/Innovative Program**

The professional staff of the school system is encouraged to seek improvement of the educational program of the schools.

Experimental programs and "pilot studies" must have the approval of the Superintendent.

Date of Adoption: May 18, 2009

**Homework**

Homework is a learning activity related to the experience within the school. Its purposes are to supplement and to enrich work done in the classrooms; to provide for individual interests; and to promote competency in skills; to use resource materials; to integrate learning and to teach the proper budgeting of time. Homework should be assigned at the discretion of the classroom teacher. Work not completed during the school day is not considered homework, but rather, the completion of assigned school work.

Date of Adoption: May 18, 2009

**Guidance**

The classroom teacher is a key figure in the guidance of youth in both the elementary and secondary schools. The counselor and teachers, by pooling their knowledge and resources, accept the students where they are and help them go as far as their potentialities permit. The students are helped to know and develop their abilities and to recognize and accept their limitations, and in this way to better understand themselves.

The guidance program includes five (5) basic services:

1. **Inventory Service.** Emphasis is placed upon a system of accurate and complete student records that accentuate the uniqueness of the individual students.
2. **Informational Service.** Information in the areas of occupational, educational and vocational guidance is made available to teachers, students and parents.
3. **Counseling Service.** For an effective program, all students are encouraged to seek individual counseling. Students with needs beyond that of the counseling program are encouraged to seek the services of private counseling.
4. **Placement Service.** This service assists students in the selection of appropriate occupations, educational institutions and work experiences.
5. **Follow-up Service.** A continuing follow-up of former students through surveys should be pursued in order to evaluate and improve the effectiveness of the school program.

**Field Trips**

Field trips shall be considered as instruction and planned as such with definite objectives determined in advance.

Teachers or other certified personnel shall accompany pupils on all field trips and shall assume responsibility for their proper conduct.

When a field trip is made to a place of business or industry, the teacher shall insist that an employee of the host company serve as conductor.

Appropriate education experience and proper supervision shall be supplied for any pupils whose parents do not wish them to participate in a field trip.

Date of Adoption: May 18, 2009

**Activities**

A vital component of a comprehensive education program is a properly supervised activities program. Such activities, properly supervised and kept in proper perspective, shall be maintained in the school program in order to give students opportunities for experiences not possible in classroom activities. Care and consideration should be given by educators, coaches, sponsors and parents to the amount of time these activities take students away from school during school hours or away from studies on "school nights."

Date of Adoption: May 18, 2009

**Activity Funds Management**

School activity funds may be expended only for purposes which may benefit the student body of the school. All rules, regulations, and procedures for the conduct, operation and maintenance of extra-curricular accounts, and for the safe-guarding, accounting and auditing of all monies received and derived therefrom are to contribute to that objective.

The accounting system for managing student activity funds shall be designed to encourage the largest possible educational return to students without sacrificing the safety of funds or exposing students to undue responsibility or unnecessary routine.

Date of Adoption: May 18, 2009

**School Colors**

The official colors of Raymond Central Public Schools shall be Navy Blue and Gold. An additional color or colors may be used for trim, but the predominant colors shall remain Navy Blue and Gold.

Date of Adoption: May 18, 2009

**Initiations, Hazing, Secret Clubs and Outside Organizations**

**Initiations.** Initiations by classes, clubs or athletic teams are prohibited except with the approval of the administration. Any student who engages in or encourages initiations that have not been approved by the administration is subject to disciplinary action, up to and including denial of any or all school privileges and expulsion.

The administration may only give consent to initiation activities that are consistent with student conduct expectations and that do not present a risk of physical or mental injury or belittlement.

**Hazing.** Hazing by classes, clubs, athletic teams or other student organizations are prohibited. Hazing means any activity by which a person intentionally or recklessly endangers the physical or mental health or safety of an individual for the purpose of initiation into, admission into, affiliation with, or continued membership with any school organization. Such prohibited hazing activity includes whipping, beating, branding, an act of sexual penetration, an exposure of the genitals of the body done with intent to affront or alarm any person, a lewd fondling or caressing of the body of another person, forced and prolonged calisthenics, prolonged exposure to the elements, forced consumption of any food, liquor, beverage, drug, or harmful substance not generally intended for human consumption, prolonged sleep deprivation, sexual conduct, nudity, or any brutal treatment or the performance of any act which endangers the physical or mental health or safety of any person or the coercing of any such activity. Hazing is prohibited even though the person who has been the subject of the hazing consents to the activity. Any student who engages in or encourages hazing is subject to disciplinary action, up to and including denial of any or all school privileges and expulsion.

**Secret Organizations.** It is unlawful for students to participate in or be members of any secret fraternity or secret organization that is in any degree a school organization. Any student who violates this restriction is subject to disciplinary action, up to and including denial of any or all school privileges and expulsion.

**Outside Organizations.** It is unlawful for any person, whether a student of the District or not, to enter upon the school grounds or any school building for the purpose of rushing or soliciting, while there, any student to join any fraternity, society, or association organized outside of the schools. Any person who violates this restriction is subject to criminal prosecution and removal and exclusion from school grounds.

Legal Reference: Neb. Rev. Stat. §§ 79-2,101 to 79-2,102

Student Discipline Act, Neb. Rev. Stat. §§ 79-254 to 79-296

Reference Neb. Rev. Stat. §§ 28-311.06 to 28-311.07

Date of Adoption: June 11, 2014

Date of Revision: July 12, 2023

**Return to Learn After Cancer**

The Superintendent or designee shall make available training on how to recognize that students who have been treated for pediatric cancer and returned to school may need informal or formal accommodations, modifications of curriculum, and monitoring by medical or academic staff.

A 504 Team meeting will be held, as appropriate, to develop individual return to learn accommodations and modifications.

Legal Reference: Neb. Rev. Stat. §§ 79-2,148

Date of Adoption: July 15, 2015

Date of Revision: July 13, 2016

### **Selection and Review of Instructional and Media Materials**

#### A) Assignment of Responsibility

The Board of Education reserves responsibility for the final acquisition of materials, but the responsibility for the selection of instructional materials is delegated to the Superintendent and Principals, with the assistance of the instructional and media staff, to establish procedures and regulations for the selection of instructional and media materials, reviewing their effectiveness, and dealing with complaints concerning instructional materials. The Superintendent may establish committees consisting of teachers and media staff to assist with these responsibilities.

#### B) Criteria for Instructional Materials

The selection of instructional materials shall be made in accordance with Board of Education policies, legal requirements, and reflect the following philosophy:

1. To provide materials that will stimulate growth in factual knowledge, practical skills, literary appreciation, aesthetic values, and ethical standards.
2. To provide a background of information which will enable students to make intelligent judgments in their daily life.
3. To provide materials that will enrich and support the curriculum, taking into consideration the varied interest, abilities, and maturity levels of the students served.
4. To provide materials on opposing sides of controversial issues so that young citizens may develop under guidance the practice of critical thinking and analysis.
5. To provide materials representative of the many religious, ethnic, and cultural groups and their contributions to our American heritage.
6. To place principle above personal opinion and reason above prejudices in the selection of materials of the highest quality in order to assure a comprehensive collection appropriate for the instructional materials.

#### C) Criteria for Media Materials

The selection of media materials shall be made in accordance with Board of Education policies, legal requirements, and with the Library Bill of Rights of the American Library Association, which Bill of Rights has been accepted by the American Association of School Librarians reflect the following philosophy:

To provide a comprehensive collection of instructional materials selected in compliance with basic, written selection principles, and to provide maximum accessibility to these materials.

To provide materials that will support the curriculum, taking into consideration the individual's needs, and the varied interest, ability, socio-economic backgrounds, and maturity levels of the students served.

To provide materials for teachers and students that will encourage growth in knowledge, and that will develop literary, cultural and aesthetic appreciation, and ethical standards.

To provide materials which reflect the ideas and beliefs of religious, social, political, historical, and

ethnic groups and their contribution to the American World Heritage and Culture, thereby enabling students to develop an intellectual integrity in forming judgments.

To provide a written statement, approved by the local Boards of Education of the procedures for meeting the challenge of censorship of materials in school library media centers.

To provide qualified professional personnel to serve teachers and students.

D) Procedures for Reconsideration of Materials

Occasional objections to some materials may be voiced despite the care taken in selection and qualification of the personnel selecting materials. The following procedures apply equally to all complaints whether they be from students, parents, school personnel or district patrons.

1. Complaints should be presented to the Principal of the school where the material is used. In the event the person with the concern does not wish to make a formal complaint, the concern may be expressed to the Principal at the school at which the material was received. The Principal shall submit informal concerns to the Superintendent for the Superintendent's consideration.
2. Formal complaints about instructional materials must be presented in writing on a form approved by the board of education. In the absence of such a form, the complainant shall be required to submit a written complaint setting forth: complainant's identity, material challenged, detailed statement of reason(s) for challenging the material, action the complainant is requesting, and such other information as the Principal may reasonably request.
3. When a formal written complaint is completed and returned to the principal, the principal will discuss the issue and the procedures to be followed in resolving the issues with the person filing the complaint. The principal with whom the complaint was filed shall notify the other school administrators and also advise those faculty members who may use the instructional material, or the media staff in the case of media material, that a complaint has been filed. The school administrators shall decide whether to appoint a building-level review committee or a district-level review committee to study the complaint. The principals will convene building-level review committees. These building-level committees shall consist of five or more committee members composed of staff and community patrons. The superintendent of schools or his designee will convene district-level review committees. These district-level committees shall consist of five or more members composed of staff and community patrons.
4. The review committees shall consider district philosophy, the professional judgment of teachers, reviews of the material by other competent authorities, compatibility with the school district's adopted curriculum, the teacher's stated goals, as well as the views of the complainant. The review committee's recommendation and all accompanying rationale shall be forwarded to the board of education for its review and final decision. The school board's decision may be to remove the material in question from district use, to modify the material for continued uses, or to reject the complaint and continue to use the material.
5. Any materials identified in a complaint may remain in use pending its review and its disposition by the board of education. Principals may, upon written request of parent(s), excuse students from using the material, or may direct teachers to use suitable substitutes, and in the case of challenged media material the Principal may place the material on a reserve shelf where it may be checked out by students only with written parent permission. However, the school shall reserve the right to require students to use material or to engage in activities which are a part of regular and/or required

curricular activities.

6. Where the same or essentially the same materials have been the subject of a challenge which has been decided by the board, and another complaint is made against the material by either the same or a different person, the complaint shall be considered by the Superintendent, who may deny the complaint without following the review procedure. In considering the complaint, the Superintendent shall consider whether the complaint raises any substantially different issue than that previously decided by the board.

Date of Adoption: May 18, 2009

**Textbook Loans**

The District will comply with the state law and Rule 4 of the Nebraska Department of Education pertaining to the distribution of textbooks to students of the District who are attending private schools. The financial liability of the District shall be limited to the amount of dollars appropriated by the state for the specific law.

If funds appropriated to this District are not sufficient to meet the request for textbooks under this policy, priority will be given to the textbooks requested that have the most recent copyright date. If the funding requires additional restrictions, priority will be given to the requests that were filed at the earliest date in the Superintendent's office. If further restrictions are necessary, a drawing shall be conducted from the names of all students filing on the same date and requesting the same texts. The drawing shall continue until all state funds provided to the District for this purpose have been spent.

Legal Reference: Neb. Rev. Stat. § 79-734  
NDE Rule 4

Date of Adoption: May 18, 2009

**Recognition of Religious Beliefs and Customs**

It is accepted that no religious belief or non-belief should be promoted by the school district or its employees, and none should be disparaged. Instead, the school district should encourage all students and staff members to appreciate and be tolerant of each other's religious views. The school district should utilize its opportunity to foster understanding and mutual respect among students and parents, whether it involves race, culture, economic background or religious beliefs. In that spirit of tolerance, students and staff members should be excused from participating in practices which are contrary to their religious beliefs unless there are clear issues of overriding concern that would prevent it.

Raymond Central Public Schools recognizes one of its educational goals is to advance the student's knowledge and appreciation of the role our religious heritage has played in the social, cultural and historical development of civilization.

Date of Adoption: May 18, 2009

**Purpose of Religion in the Curriculum**

The practice of Raymond Central Public Schools shall be as follows:

1. The District supports the inclusion of religious literature, music, drama and the arts in the curriculum and in school activities provided it is intrinsic to the learning experience in the various fields of study and is presented objectively.
2. The emphasis on religious themes in the arts, literature and history should be only as extensive as necessary for a balanced and comprehensive study of these areas. Such studies should never foster any particular religious tenets or demean any religious beliefs.
3. Student initiated expressions to questions or assignments which reflect their beliefs or non-beliefs about a religious theme shall be accommodated. For example, students are free to express religious belief or non-belief in compositions, art forms, music, speech and debate.

Date of Adoption: May 18, 2009

### **Multicultural Education**

Raymond Central Public Schools incorporates multicultural education in all curriculum areas at all grades. Multicultural education includes, but is not limited to, studies relative to the culture, history, and contributions of African Americans, Hispanic Americans, Native Americans, Asian Americans and European Americans with special emphasis on human relations and sensitivity toward all races.

#### **Statement of Philosophy and Mission**

The philosophy of the multicultural education program is that students will have improved ability to function as productive members of society when provided with: (a) an understanding of diverse cultures and races, the manner in which the existence of diverse cultures and races have affected the history of our Nation and the world, and of the contributions made by diverse cultures and races and (b) with the ability and skills to be sensitive toward and to study, work and live successively with persons of diverse cultures and races.

The mission of the multicultural education program is to prepare students to: (a) value and respect their own culture and race and cultures and races other than their own and (b) eliminate stereotypes and different treatment of others based on culture and race. The mission shall also include preparing students to eliminate stereotypes and discrimination or harassment of others based on ethnicity, religion, gender, socioeconomic status, age, or disability.

#### **Implementation of Multicultural Education**

The philosophy and mission of the multicultural education program is to be implemented as follows:

1. Multicultural education shall be included in goals established for educational programs.
2. Multicultural education shall be included in the district curriculum guides, frameworks, or standards.
3. The process for selecting appropriate instructional materials shall include assuring that the instructional materials at all grade levels include studies relative to the culture, history, and contributions of African Americans, Hispanic Americans, Native Americans, Asian Americans and European Americans with special emphasis on human relations and sensitivity toward all races.
4. Staff development shall be provided on the District's multicultural education policy. The staff development shall include professional development for administrators, teachers, and support staff which is congruent with the District and program goals.
5. Periodic assessment of the multicultural education program shall be conducted by the Superintendent. Teachers and other staff upon request shall have the responsibility to provide the administration with reports on: (a) the instructional materials used and programs or methods implemented with their students which are supportive of the multicultural education program philosophy and mission, (b) programs or materials to be implemented in the future or which teachers or other staff feel should be implemented to further advance such philosophy and mission, and (c) with their professional assessment on the successes of or deficiencies in achieving the multicultural education program philosophy and mission. The Superintendent shall provide an annual status report on the assessment to the Board of Education.

Legal Reference: Neb. Rev. Stat. §§ 79-719 to 79-723  
Nebraska State Board of Education Rule 10

Date of Adoption: May 18, 2009

**Equal Opportunity: Instruction Program**

The school district pledges itself to avoid discriminatory actions, and seeks to foster good human and educational relations which help to attain:

1. Equal rights and opportunities for students and employees in the school community.
2. Equal opportunity for all students to participate in the instructional program of the schools.
3. Continual study and development of curricula toward improving human relations and understanding and appreciating cultural differences.
4. Frequent training opportunities for improving staff responsiveness to educational and social needs.
5. Opportunities in educational programs which are broadly available to pupils which are not solely based upon sex, disability, race, color, religion, veteran status, national or ethnic origin, age, marital status, pregnancy, childbirth or related medical condition, sexual orientation or gender identity, or other protected status.

Date of Adoption: May 18, 2009

Date of Revision: July 15, 2020

**Controversial Issues**

Controversial issues exist where there are sharp differences of opinion concerning an idea or a line of action. In order that students may develop intelligent attitudes and understandings concerning significant aspects of living, they should be afforded opportunities within the classroom to deal with such issues to the extent appropriate for their level of maturity and the educational mission of the District.

In considering such issues, it shall be the purpose of our schools to provide students the opportunity:

1. To study controversial issues concerning which the students, at their level of maturity, should have begun to form an opinion or to seek information about.
2. To have access to all relevant, educationally appropriate information, including the materials that circulate freely in the community.
3. To study under competent instruction in an atmosphere of freedom from bias and prejudice.
4. To form, and in an appropriate manner and in an appropriate forum, to express the students' own judgments on controversial issues.
5. To recognize that reasonable compromise is often an important facet in decision making in our society.
6. To respect the opinions of others.

Date of Adoption: May 18, 2009

**Combined District and School Title I Parent and Family Engagement Policy**

The Raymond Central Public School District intends to follow the Title I Parent and Family Engagement Policy guidelines in accordance with federal law, *Section 1116(a-f) ESSA, (Every Student Succeeds Act) of 2015*.

**In General**

The written District parent and family engagement policy has been developed jointly with, updated periodically and distributed to parents and family members of participating children and the local community in an understandable and uniform format. This policy agreed on by such parents describes the means for carrying out the requirements as listed below.

- Parents and family members of all students are welcomed and encouraged to become involved with their child's school and education; this includes parents and family members that have limited English proficiency, limited literacy, are economically disadvantaged, have disabilities, racial or ethnic minority background or are migratory children. Information related to school and parent programs, meetings, school reports and other activities are sent to the parents of participating children in a format, and to the extent practicable, in a language the parents can understand.
- Parents are involved in the planning, review, evaluation and improvement of the Title I program, Parent and Family Engagement Policy and the School-Parent Compact at an annual parent meeting scheduled at a convenient time. This would include the planning and implementation of effective parent and family involvement activities.
- Conduct, with meaningful parent and family involvement, an annual evaluation of the content and effectiveness of the Parent and Family Engagement Policy. Use the evaluation findings to design evidence-based strategies for more effective parental involvement, and to revise the Parent and Family Engagement Policy.
- Opportunities are provided for parents and family members to participate in decisions related to the education of their child/children. The school and local educational agency shall provide other reasonable support for parental involvement activities.
- Parents of participating children will be provided timely information about programs under this part, a description and explanation of the curriculum in use, the forms of academic assessment used to measure student progress and the achievement levels of the challenging State academic standards. The school will provide assistance, opportunities, and/or materials and training to help parents work with their children to improve their children's academic achievement in a format, and when feasible, in a language the parents and family members can understand.
- Educate teachers, specialized instructional support personnel, principals, and other school leaders, with the assistance of parents in the value and utility of contributions of parents, how to reach out to, communicate with and work with parents as equal partners.
- Coordinate and integrate parental involvement programs and activities with other Federal, State and local programs, including preschool programs that encourage and support parents in more fully participating in the education of their children.

Legal Authorities: 20 U.S.C. §§ 6318 and 7801(32)

Date of Adoption: May 18, 2009

Date of Revision: June 10, 2019

## **Special Education**

Raymond Central Public Schools adopts this special education policy with the intent that the policy maintains the District's compliance with all applicable laws affecting special education services and programs. The Superintendent or designees shall develop regulations or procedures to implement these policies. Employees and contractors of the District are expected to comply with these policies and all regulations, guidelines and procedures related to this policy in all respects.

The District will abide by all state and federal laws relating to special education. The District's special education policy and regulations, guidelines and procedures related to this policy are to be interpreted so as to be in compliance with such laws. In the event of changes in law, the school administration shall be authorized to implement modifications of practice to comply with such changes (whether the changes impose more or less stringent procedural or substantive requirements) until such time as amended policies are adopted by the Board of Education. References herein to 92 NAC 51 citations are made to Rule 51 as in effect on the date of the adoption of these policies. In the event of renumbering or other revisions to Rule 51, the policy shall be interpreted and implemented consistent with such renumbering or revisions.

### **1. Free Appropriate Public Education**

A free appropriate public education shall be made available to all children with disabilities residing in the District, including children with disabilities who have been suspended or expelled, from date of verification through the school year in which the child is no longer eligible or the student reaches twenty-one (21) years of age, whichever occurs earlier. An Individualized Education Plan ("IEP") will be created for each such child that will enable the student to make appropriate progress in light of the student's unique circumstances.

Legal Reference: 92 NAC 51-004.01 through 004.03A and 007.07C2 through 007.07C6

### **2. Full Educational Opportunity Goal**

The District shall take steps to ensure that its children with verified disabilities, through the age of twenty-one, have available to them the variety of educational programs and services available to children without disabilities in the areas served by the District, including art, music, industrial arts, family consumer science education, and vocational education.

Legal Reference: 92 NAC 51-004.11A

### **3. Child Find**

All children from birth to age twenty-one (21) with disabilities residing in the District, including children with disabilities who are homeless or are wards of the state or attending nonpublic schools, regardless of the severity of their disabilities, who are in need of special education and related services, will be identified, located and evaluated. A practical method shall be developed and implemented by the administration to determine which children with disabilities are currently receiving needed special education and related services. The District will implement multiple methods to provide parents, guardians, and community members with information regarding how to refer a child for an evaluation and the identification process and will publish an annual notice of any significant activity that is designed to identify, locate, or evaluate children to publicly notify parents, guardians, or appointed surrogates. The District's child find process will be consistent with Federal and Nebraska regulations.

Legal Reference: 92 NAC 51-006.01 through 006.01A2

**4. Pre-Referral Interventions**

For a school age student, a general education student assistance team (SAT) or a comparable problem solving team shall be used prior to referral for multidisciplinary team evaluation. The SAT or comparable problem solving team shall utilize and document problem solving and intervention strategies to assist the teacher in the provision of general education. If the student assistance team or comparable problem solving team feels that all viable alternatives have been explored, a referral for multidisciplinary evaluation shall be completed. A referral shall include information from the SAT or comparable problem solving team, meeting the requirements of 92 NAC 51-006.01B and a listing of the members of the SAT or comparable problem solving team.

Legal Reference: 92 NAC 51-006.01B

**5. Disability Verification and Eligibility**

Eligibility for services will be determined by a multidisciplinary team based on the results of a comprehensive evaluation. The multidisciplinary team will identify whether a child is eligible for special education services based on the disability categories identified by Nebraska and Federal regulations. The multidisciplinary team will rule out the determinant factor is due to a lack of appropriate instruction in reading or math or due to lack of English proficiency. The team will prepare a written report documenting all evaluation findings in accordance with Federal and Nebraska requirements that will be provided to the parent, guardian, or appointed surrogate. When a child is not eligible for services, the multidisciplinary team will determine if general education interventions or strategies are needed.

Legal Reference: 92 NAC 51-006.03; 92 NAC 51-006.04B through 006.04N;

**6. Individualized Education Program (IEP)**

An individualized education program, or an individualized family service plan, is to be developed, reviewed, and revised for each child with a disability in accordance with 92 NAC 51-007 by teams that will include all roles identified within Federal and Nebraska rules. Any draft of an IEP that is developed will not be considered final until it is reviewed and revised based on the team, including the parent, guardian, or appointed surrogate, input, and consensus. The district will make reasonable efforts to obtain informed consent from the parent, guardian, or appointed surrogate for special education placement on the IEP form before services are initiated. Revocation of consent for services must be documented by the parent, guardian, or appointed surrogate in writing.

Legal Reference: 92 NAC 51-007

**7. Least Restrictive Environment**

To the maximum extent appropriate, children with disabilities, through the age of twenty-one, including children in public or private institutions or other care facilities, are to be educated with children who are not disabled. Placement for a student with a disability will be based upon a completed IEP developed by a group of persons, including the parent, guardian, or appointed surrogate, knowledgeable about the child, the meaning of the evaluation data, and the placement options. Special classes, separate schooling, or other removal of children with disabilities from the regular educational environment will occur only when the nature or severity of the disability of a child is such that education in regular classes with the use of supplementary aids and services cannot be achieved satisfactorily (the "Least Restrictive Environment Rules"). The District will ensure that a continuum of alternative placements is available to meet the needs of children with disabilities, particularly those in disproportionate groups, for special education and related services.

Legal Reference: 92 NAC 51-008.01

**8. Procedural Safeguards**

Children with disabilities and their parents, guardians, or appointed surrogates shall be afforded the required procedural safeguards. Parents, guardians, and appointed surrogates will be given a copy of their procedural safeguards annually or upon initial referral or parental (parent, guardian, or appointed surrogate) request for evaluation; upon request by a parent, guardian, or appointed surrogate; upon receipt by the school district or approved cooperative of the first occurrence of the filing of a complaint under 92 NAC 51-009.11 and the first occurrence of filing a special education due process case under 92 NAC 55; and in accordance with the discipline procedures in 92 NAC 51-016.

Legal Reference: 92 NAC 51-009.01 through 009.07; 009.10 through 009.12; 009.14, 006.07

**9. Disciplinary Removal of Children with Disabilities**

School personnel may remove a child with a disability who violates a code of student conduct from his or her current placement to an appropriate interim alternative educational setting, another setting, or suspension as long as those removals do not constitute a change of placement. The District defines a change of placement as it is defined under 92 NAC 51-016. The school district will ensure that school personnel appropriately consider unique circumstances on a case-by-case basis when determining whether a change in placement has occurred. Within 10 school days of any decision to change the placement of a child with a disability because of a violation of a code of student conduct, the school district, the parent, and relevant members of the student's IEP shall conduct a manifestation determination pursuant to 92 NAC 51-016. If the conduct which gave rise to the violation of the school code is determined to be a manifestation of the student's disability, any change of placement for the student will only be made by a student's IEP team. For disciplinary changes in placement that would exceed ten (10) consecutive school days, if the behavior that gave rise to the violation of the school code is determined not to be a manifestation of the child's disability, school personnel may apply the relevant disciplinary procedures to children with disabilities in the same manner and for the same duration as the procedures that would be applied to children without disabilities.

Legal Reference: 92 NAC 51-016

**10. Evaluation, Identification, and Reevaluation Procedures**

Children with disabilities shall be evaluated, identified, and reevaluated by a team of multidisciplinary qualified professionals in accordance with 92 NAC 51-006. The MDT of a child suspected of having a specific learning disability shall include the additional requirements in accordance with 92 NAC 51-006.04K. The District will make reasonable efforts to obtain written permission for evaluation in accordance with Federal and Nebraska rules. Revocation for consent for evaluation must be documented by the parent, guardian, or appointed surrogate in writing.

The documented results of the evaluation will be provided to parent, guardian, or appointed surrogate and included in student files. All evaluation components will be at district expense. The District will utilize a variety of assessment instruments to ensure district teams have access to appropriate measures to complete evaluations. The district will follow any publisher guidelines for assessments and will not use outdated or culturally inappropriate tools.

The District will respond to a request for an Independent Educational Evaluation without unnecessary delay. The parent, guardian, or appointed surrogate will be given written notice of the District's decision to either move forward with the Independent Educational Evaluation or to initiate a hearing to determine the appropriateness of the evaluation. If the District agrees to move forward with the evaluation, locations of any evaluator shall be within a reasonable distance of the District. A reasonable distance means within 100 miles of the school building the child attends and within Nebraska. In the event this geographic area restriction would prevent a parent, guardian, or appointed surrogate from obtaining an Independent Educational Evaluation, the location of the evaluator may be outside the specified geographic area but must be within Nebraska. The District will provide the parent, guardian,

or appointed surrogate with a list of qualified agencies/evaluators within the geographic area. The evaluators are to have their rates approved by the Nebraska Department of Education to be authorized to conduct the evaluation.

Legal Reference: 92 NAC 51-006

**11. Confidentiality of Personally Identifiable Information**

A system of safeguards will be implemented to protect the confidentiality of student records and information in accordance with law.

Legal Reference: 92 NAC 51-003.16, 003.20, 009.03 through 009.03M3

**12. Transition of Children from Part C to Preschool Programs**

**Children participating in early intervention programs under Part C of the IDEA (early intervention services) will be appropriately evaluated, identified, and have services under Part B of the IDEA by age 3 in a manner consistent with 92 NAC 52-008. Children receiving early intervention services under Part C of the IDEA may continue to receive Part C services, upon parental consent, until August 31st following the child's third birthday. The District will participate in transition planning conferences arranged by the designated lead agency.**

Legal Reference: 92 NAC 52-008

**13. Children in Nonpublic Schools**

To the extent consistent with the number and location of children with disabilities in the District who are enrolled by their parents, guardians, or appointed surrogates in nonpublic elementary and secondary schools in the District, provision will be made for the participation of those children in the programs assisted or carried out under Part B of the IDEA (services for school-aged children) by providing them with special education and related services.

Legal Reference: 92 NAC 51-012.08 and 015

**14. Personnel Standards and Personnel Development**

Personnel providing special education or related services to children with disabilities shall be appropriately and adequately prepared and trained in accordance with IDEA requirements and the District will take measurable steps to recruit, hire, train and retain personnel meeting the requirements of IDEA to provide such services.

Legal Reference: 92 NAC 51-010

**15. Accessibility of IEP and Responsibility to Implement**

A child's IEP shall be accessible to each regular education teacher, special education teacher, related service provider, and other service provider who is responsible for the IEP's implementation. Each of the aforementioned providers shall be informed of his or her specific responsibilities related to implementing the child's IEP, and the specific accommodations, modifications, and supports that must be provided for the child in accordance with the IEP. All providers who are responsible for the implementation of a child's IEP are expected to implement the child's IEP according to its terms.

**16. Participation in and Reporting of State and District Wide Assessments**

All children with disabilities shall be included in all general state and district wide assessment programs, including assessments described under section 612(a)(16)(A) of the IDEA with appropriate accommodations and alternate assessments where necessary and as indicated in their respective individualized education programs. The District will make available to the Nebraska Department of Education the information necessary to carry out its duties relating to the reporting of children with disabilities participation in assessments.

Legal Reference: 92 NAC 51-004.05

**17. Suspension and Expulsion Rates**

The District will examine data, including data disaggregated by race/ethnicity, gender, LEP status, and disability category, to determine if significant discrepancies are occurring in the rate of long-term suspensions and expulsions of children with disabilities.

Legal Reference: 92 NAC 51-004.06E

**18. Access to Instructional Materials**

As part of any printed instructional materials adoption process, procurement contract, or other practice or instrument used for purchase of printed instructional materials, the District will enter into a written contract with the publisher of the printed instructional materials to:

- A. Require the publisher to prepare and, on or before delivery of the print instructional materials, provide to the National Instructional Material Access Center, electronic files containing the contents of the printed instructional materials using the National Instructional Materials Accessibility Standard, or
- B. Purchase instructional materials from the publisher that are produced in, or may be rendered in specialized formats.

Legal Reference: 92 NAC 51-004.15

**19. Over-Identification and Disproportionality**

Procedures shall be in place to ensure that testing and evaluation materials and procedures utilized for the evaluation and placement of children with disabilities will be selected and administered so as not to be racially or culturally discriminatory. Such materials or procedures shall be provided and administered in the child's native language or mode of communication, unless it is clearly not feasible to do so, and no single procedure shall be the sole criterion for determining an appropriate educational program for a child. All District special education provisions will be equitably available to all children regardless of race, ethnicity, language, location, transience, income level, and access to medical care.

Legal Reference: 92 NAC 51-006.02C

**20. Prohibition on Mandatory Medication**

Children shall not be required to obtain a prescription for a controlled substance as a condition of attending school, receiving an evaluation to determine whether a child has a disability or the nature and extent of special education and related services the child needs, or receiving special education services.

Legal Reference: 92 NAC 51-004.11D; 21 U.S.C. §812(c)

**21. Transportation**

Transportation will be provided for children with disabilities who are eligible for transportation and residents of the school district as required by law to access academic, related services, and nonacademic services and activities as determined by the child's IEP. Except when a parent is transporting only his or her child, the District shall require that the driver and vehicle meet the standards required by 92 NAC 91 and 92.

Legal Reference: 92 NAC 51-014.01 through 014.02

**22. Surrogates**

A surrogate will be appointed, and other action taken to ensure the rights of children with a disability as required by law. The surrogate may represent the child in all matters related to the identification, evaluation, and educational placement of a child and the provision of a free appropriate public education to the child.

Legal Reference: 92 NAC 51-009.10

**23. Early Intervention Services – Consent**

When a parent refuses to provide consent under 92 NAC 52, a meeting will be held or offered to explain to the parents how their failure to consent affects the ability of their child to receive services under 92 NAC 52.

Legal Reference: 92 NAC 52

Legal Reference: 34 CFR Parts 300, 303 and 304  
Neb. Rev. Stat. Sec. 79-1110 to 79-1167  
92 NAC 51, 52 and 55

Date of Adoption: August 15, 2011  
Date of Revision: July 12, 2023

**Firearm Policy**

It shall be the policy of the Raymond Central Public School District to undertake all reasonable efforts to prohibit the unlawful possession, the knowingly and intentionally selling, attempting to sell, providing, loaning, delivering, or in any other way transferring the possession of a firearm to a juvenile, and to prevent the unlawful possession of a firearm, including concealed firearms, in a school, on school grounds, in a school owned vehicle, or at a school sponsored activity or athletic event. This policy shall not apply to the issuance of firearms to or possession by members of the Armed Services of the United States, active or reserve, National Guard of the State, or reserve officers training corp, peace officers, off duty cops, or other duly authorized law enforcement officers when on duty or training or when contracted by a school to provide school security or school event contract services. Further, nothing in this policy shall be construed to require school action when a firearm is lawfully possessed by a person receiving instruction, or instruction under the immediate supervision of an adult instructor, or as to firearms contained within a private vehicle operated by a non-student adult when the firearm is not loaded, is encased, and is either in a locked firearm rack that is on a motor vehicle or is in a case that is expressly made for the purpose of containing a firearm and that is completely zipped, snapped, buckled, tied or otherwise fastened with no part of a firearm exposed.

Any unlawful use or possession of a firearm, including concealed firearms, as described in this policy and as described by statute shall as soon as is reasonably possible be reported to an appropriate peace officer. Nothing in this policy shall be construed to prevent the district from carrying out regular disciplinary procedures as have been adopted by the Board of Education or as otherwise authorized by law.

Legal Reference: Neb. Rev. Stat. § 28-1204.04

Date of Adoption: May 18, 2009

Date of Revision: July 12, 2023

## **Chronic Infectious Disease Practice and Procedure**

### **A. Infectious Diseases**

1. This policy applies to any disease not known to be spread by casual, incidental contact. Such diseases include but are not limited to AIDS and Hepatitis B.
2. The safety and health of the students and staff of Raymond Central Public Schools is of ultimate concern. The determination of whether an infected student or employee of the Raymond Central Public School System should be permitted to attend classes, participate in school activities or remain on the job will be made on a case-by-case basis.
3. In making this determination the following factors will be taken into consideration:
  - a. The behavior, neurological development and physical condition of the infected person.
  - b. The expected type of interaction with others in the school setting.
  - c. The impact on both the infected person and others in that setting.
4. The determination of whether or not an infected person remains in the school or school system will be based solely on scientific and medical evidence. Legal advice may also be sought by the district.
5. If determination of whether or not an infected person poses an imminent threat to the health and safety of the school, community or the individual's conduct presents a clear threat to the physical safety of himself/herself or others, then with respect to an infected student, Nebraska Revised Statutes Section 79-264 will be followed concerning exclusion from school. With respect to an infected certified employee of the school district, the provision of Nebraska Revised Statutes, Section 79-838 will be followed with respect to leave of absence.
6. If an infected student in grades K through 12 is not permitted to attend classes, the school will make every reasonable effort to provide the student with an adequate alternative education.
7. Any person with an infectious disease will retain the rights of confidentiality and privacy. Information and discussion with regard to the case will be limited to those who must have information to deal with the situation. If necessary, the community will be informed that an infectious disease is present in the school system and that the person will be excluded only if the situation warrants such action based upon medical and legal advice. No information will be given out about the individual, his/her medical record or about the family without written permission of the individual (adult) or parent/legal guardian of the student.

### **B. Bloodborne Pathogens**

1. First aid may be rendered in situations involving the presence of blood or other potentially infectious materials (hereinafter "bloodborne pathogen situations") by the school nurse, and by such other employees as the Superintendent shall designate. All non-designated employees shall refer bloodborne pathogen situations to a designated employee, and shall not be required to personally render first aid in bloodborne pathogen situations or be disciplined for failure to personally render first aid in bloodborne pathogen situations.
2. An employee who has an employment related bloodborne pathogen exposure incident (an incident

in which another person's blood or other potentially infectious material contacts the employee's eye, mouth, mucous membrane, non-intact skin, or pierced mucous membrane or skin barrier) shall promptly give notice of the incident and details of the incident to the superintendent or the superintendent's designee.

3. The Superintendent shall be authorized and required to take such action and adopt such plans as may be required to place this School District in compliance with OSHA regulations concerning bloodborne pathogens, in the event and at such time as this School District may become subject to OSHA regulation.

Date of Adoption: May 18, 2009

**Student Self-Management of Asthma, Anaphylaxis, and/or Diabetes**

Students with asthma, anaphylaxis or diabetes will be permitted to self-manage such medical conditions upon:

1. written request of the student's parent or guardian;
2. authorization of the student's physician or, for asthma and anaphylaxis, a health care professional who prescribed the medication for treatment of the student's condition;
3. receipt of a signed no liability statement from the parent or guardian; and
4. development of an asthma or anaphylaxis or a diabetes medical management plan for the student.

Students with such a medical management plan may possess the necessary medication to manage their medical condition upon the conditions established in the plan and not be subject to discipline for such possession. Provided that, if the student uses or allows the medication to be used for any reason other than as prescribed or as provided in the plan or possesses the medication other than as provided in the plan the student shall be subject to discipline in accordance with the student conduct and drug-free school policies.

Legal Reference: Neb. Rev. Stat. §§ 79-224 and 79-225

Date of Adoption: May 18, 2009

Date of Revision: July 13, 2016

Dated: \_\_\_\_\_

**ASTHMA OR ANAPHYLAXIS MEDICAL MANAGEMENT PLAN**

**I. CONTACT AND PLAN INFORMATION**

**Student's Name:** \_\_\_\_\_ **Date of Birth:** \_\_\_\_/\_\_\_\_/\_\_\_\_

(Month) (Day) (Year)

**Health Condition:**     Asthma             Anaphylaxis (For this Plan "Health Condition" means the condition(s) checked)

**Mother/Guardian:** \_\_\_\_\_

Address: \_\_\_\_\_

Telephone: Home \_\_\_\_\_ Work \_\_\_\_\_ Cell \_\_\_\_\_

**Father/Guardian:** \_\_\_\_\_

Address: \_\_\_\_\_

Telephone: Home \_\_\_\_\_ Work \_\_\_\_\_ Cell \_\_\_\_\_

**Student's Doctor/Health Care Provider:** \_\_\_\_\_

Address: \_\_\_\_\_

Telephone: \_\_\_\_\_ Emergency Number: \_\_\_\_\_

**Other Emergency Contacts:** \_\_\_\_\_

Relationship: \_\_\_\_\_

Telephone: Home \_\_\_\_\_ Work \_\_\_\_\_ Cell \_\_\_\_\_

**II. PARENT OR GUARDIAN**

**AUTHORIZATION, APPROVAL AND LIABILITY WAIVER**

The parents or guardians (hereinafter "Parent") request that Raymond Central Public Schools allow the Student to self-manage the health condition and accept and agree to this Medical Management Plan. The Guidelines for Asthma or Anaphylaxis Medical Management Plan are incorporated into and are a part of this Plan.

Parents understand and agree that if the Student injures school personnel or another student as the result of the misuse of necessary asthma or anaphylaxis medical supplies, Parents shall be responsible for any and all costs associated with such injury. Parents acknowledge that (a) the school and its employees and agents are not liable for any injury or death arising from the Student's self-management of the Student's Health Condition and Parents release same from any such claims and (b) Parents shall and do hereby agree to indemnify and hold harmless the school and its employees and agents against any claim arising from the Student's self-management of Student's Health Condition. This release, indemnification and hold harmless agreement shall take effect immediately and shall stay in effect for as long as the Student is provided permission to self-administer medication.

Parent/guardian signature: \_\_\_\_\_ Date: \_\_\_\_\_

Parent/guardian signature: \_\_\_\_\_ Date: \_\_\_\_\_

**III. STUDENT AGREEMENT**

I will use the prescription asthma or anaphylaxis medication only as prescribed and as permitted by the Plan. I will not share the medication with others and I will not create an unnecessary distraction to others. I have been instructed how to self-administer this medication and understand the side effects of improper use and will promptly report self-administration and follow the Guidelines. I understand that if I do not abide by these terms, I may be disciplined and that this Plan will be re-evaluated. I release the school and its employees of any liability any in way related to this Plan or my use of the medication.

Student signature: \_\_\_\_\_ Date: \_\_\_\_\_

Dated: \_\_\_\_\_

**IV. MEDICAL MANAGEMENT PLAN**

**A. Health care services the Student may receive at school relating to Student's Health Condition:** See Guidelines (Part V).

**B. Evaluation of Student's understanding of and ability to self-manage Student's Health Condition.**

The parents/guardians and the Physician certify that the Student has a sufficient level of understanding and ability to self-manage the Student's Health Condition as follows:

1. Access to Prescription Asthma/Anaphylaxis Medication

- May have medication in Student's possession at any time.
- May have medication in Student's possession when the health office is not accessible (for example, when the Student is out of the school on field trips or participating in extracurricular activities) but should otherwise be maintained in the health office.
- May not have medication in Student's possession except for emergency use.

2. Self-Administration of Prescription Asthma/Anaphylaxis Medication

- May self-administer independently and without supervision. The Student has had had training and is proficient in self-administering medication.
- May self-administer when the health office or school staff authorized to administer medication are not readily accessible (for example, when the Student is out of the school on field trips or participating in extracurricular activities); but should otherwise have medication administered by the health office or authorized school staff.
- May not self-administer except for emergency use.

**C. It is agreed that this Plan permits regular monitoring of Student's self-management of Student's Health Condition by an appropriately credentialed health care professional.**

**D. Name, purpose and dosage of prescription asthma or anaphylaxis medication prescribed for Student:** See Student Asthma/Anaphylaxis Action Plan (Part IV(F)).

**E. Procedures for storage and access to backup supplies of such prescription medication for Student's Health Condition:**

1. The Student, when permitted to be in possession of medication, will have only the prescription medication that might be needed for the Student's own use. For example, the Student may have one inhaler, but not two, unless the first is nearly empty
2. The school will store any backup supply needed in accordance with its medication storage procedures.
3. The student may have access to the backup supply when necessary by requesting such from the health office.

**F. Student Asthma/Anaphylaxis Action Plan**

**Student Name:** \_\_\_\_\_ **Date of Birth:** \_\_\_\_/\_\_\_\_/\_\_\_\_  
 (Month) (Day) (Year)

**EXERCISE PRECAUTION** - Administer inhaler 15-30 minutes before exercise (eg, gym class, recess)

- Albuterol inhaler (Proventil, Ventolin) 2 inhalations

**ASTHMA TREATMENT**

Give or self-administer *quick relief medication* when Student experiences asthma symptoms such as, coughing, wheezing, or tight chest.

**Quick relief medication:**

- Albuterol inhaler (Proventil, Ventolin) 2 inhalations
- Pirbuterol inhaler (Maxair) 2 inhalations
- Albuterol inhaled *by nebulizer* (Proventil, Ventolin)
  - 0.63 mg/3 mL
  - 1.25 mg/3 mL
- Levalbuterol inhaled *by nebulizer* (Xopenex)
  - 0.31 mg/3 mL
  - 0.63 mg/3 mL
  - 1.25 mg/3 mL
- May carry and self-administer metered-dose inhaler per Part IV(B) of Medical Management Plan.

**IF SCHOOL STAFF INVOLVED-- CLOSELY OBSERVE STUDENT AFTER QUICK RELIEF ASTHMA MEDICATION IS ADMINISTERED**

**If after 10 minutes:**

- Symptoms are improved, student may return to classroom after notifying parent/guardian.
- If no improvement in symptoms, repeat the above medication and notify parent/guardian immediately and determine student’s ability to remain in school for the day.
- ***If student continues to worsen CALL 911 and INITIATE Emergency Response to Life-Threatening Asthma or Systemic Allergic Reactions Protocol (Asthma).***

**ANAPHYLAXIS TREATMENT**

Give or self-administer *epinephrine* when Student experiences allergy symptoms, such as hives, difficulty breathing (chest or neck “sucking in”), lips or fingernails turning blue, or trouble talking (shortness of breath).

- The Student has severe allergies to the following:  
 \_\_\_\_\_

- Epinephrine injection (please specify):
  - EpiPen 0.3 mg                       Twinject 0.3 mg
  - EpiPen Jr. 0.15 mg               Twinject 0.15 mg
- May carry and self-administer epinephrine injection per Part IV(B) Medical Management Plan.

**IF SCHOOL STAFF INVOLVED--CLOSELY OBSERVE STUDENT AFTER EPINEPHRINE IS ADMINISTERED**

- ***CALL 911 and closely observe the student.***
- Notify parent/guardian immediately.
- Even if student improves, the student should be observed for recurrent symptoms of anaphylaxis in an emergency medical facility.
- ***If student does not improve or continues to worsen, INITIATE Nebraska’s schools Emergency Response to Life-Threatening Asthma or Systemic Allergic Reactions Protocol (Anaphylaxis).***

Possible adverse reactions to be reported to physician \_\_\_\_\_

Special instructions \_\_\_\_\_

I am the Student’s Physician. Student has  Asthma  Anaphylaxis and has been prescribed the medication referenced above. Student has the ability to safely and responsibly self-manage Student’s Health Condition in accordance with this Asthma or Anaphylaxis Medical Management Plan. I approve the Medical Management Plan and the Student Asthma/Anaphylaxis Action Plan and authorize Student to self-manage Student’s Health Condition at school in accordance with the Plan.

Physician signature: \_\_\_\_\_ Date: \_\_\_\_\_

Dated: \_\_\_\_\_

**V. GUIDELINES FOR  
ASTHMA OR ANAPHYLAXIS MEDICAL MANAGEMENT PLAN**

**Term of Plan:** The plan is effective for the current school year. A new plan must be established each school year or more often if changes occur to the student's health or prescribed treatment or student's ability to self-manage.

**Medications:** The parents or guardians are responsible for supplying any and all prescription asthma/anaphylaxis medications required under the Plan; the school is not responsible for providing the medications. Prescribed asthma/anaphylaxis medications to be used by the Student under this Plan must be furnished in a current original container from the pharmacy with the student's name and the name of the medication, and where applicable, the strength and the dosage to be given. Inhalers must have a label attached to the inhaler itself, not on the packaging. If the prescribed medication, dosage or time of medication changes, the parents or guardians must promptly submit to the school nurse or designee the new prescription and as necessary a new asthma/anaphylaxis action plan. Any non-prescription medication must be furnished in the original container from the manufacturer. The school will store any backup supply needed in accordance with its medication storage procedures. The student may have access to the backup supply when necessary by requesting such from the health office.

**Health care services the Student may receive at school relating to Student's Health Condition.**

1. Standard health services available to all students.
2. Storage of backup asthma or anaphylaxis medication supplies.
3. Recording of student self-administration reports.

**Consultations:** The school may consult with a registered nurse or other health care professional employed by such school during development of the plan.

**Permitted Self-Management:** Pursuant to the Asthma or Anaphylaxis Medical Management Plan the Student shall be permitted to self-manage the Student's asthma or anaphylaxis condition in the classroom or any part of the school or on school grounds, during any school-related activity, or in any private location specified in the plan.

**Student Reports of Self-Administration:** The Student shall promptly notify the school nurse, the school nurse's designee, or another designated adult at the school when the Student has self-administered prescription asthma or anaphylaxis medication pursuant to the Plan.

**Responses to Student Misuse:** The possession of medications by Students is a violation of the school's drug and student conduct policies and may result in an expulsion from school. To the extent this Asthma or Anaphylaxis Medical Management Plan permits the Student to be in possession of prescribed asthma/anaphylaxis medications, the Plan allows the Student an exception to the school drug and student conduct policies. However, this exception only extends to the extent provided in the Plan. In the event the Student uses his or her prescription asthma or anaphylaxis medication other than as prescribed, or possesses medication other than as permitted by the Plan, the Student is subject to disciplinary action by the school, up to and including an expulsion. The school will promptly notify the parent or guardian of any disciplinary action imposed. The disciplinary action will not include a limitation or restriction on the student's access to such medication; however, it is agreed that in the event of any such misuse, a re-evaluation of the Student's understanding of and ability to self-manage Student's Health Condition will occur and the re-evaluation may result in a modification or termination of this Plan.

**Sharing Plan:** It is agreed that this Asthma or Anaphylaxis Medical Management Plan may be shared with school officials and agents who have a need to be aware of it; that those who have the need to be aware of it include student health staff and also include staff responsible for student discipline (e.g. staff need to know that the Student is authorized to have the medication on the Student's person so the Student is not reported for a violation of the school's drug policies). The school officials who may be informed of the Plan thus include: administration, school nurse, school office staff, teachers and any paraeducators or specialists who provide services to the Student, and the coaches and sponsors of extracurricular activities in which the Student participates.

**Filing of Plan:** This Asthma or Anaphylaxis Medical Management Plan is to be kept on file at the school where the Student is enrolled.

Asthma or Anaphylaxis Medical Management Plan for \_\_\_\_\_ (Student)

Dated: \_\_\_\_\_

**VI. SCHOOL NURSE ACKNOWLEDGEMENT OF  
ASTHMA OR ANAPHYLAXIS MEDICAL MANAGEMENT PLAN**

- Parent Request and Liability Waiver signed     Student Agreement signed.
- Management Plan (including Action Plan) signed by Physician.
- Guidelines reviewed with the Student and Parent/Guardian.
- Copy of Guidelines and Student Agreement received by Parent/Guardian for reference.

School Nurse or designee signature: \_\_\_\_\_ Date: \_\_\_\_\_

Asthma or Anaphylaxis Medical Management Plan for \_\_\_\_\_ (Student)

Dated: \_\_\_\_\_

**Asthma/Allergy Self-Management Log**

Student Name \_\_\_\_\_

Student Date of Birth \_\_\_\_\_

Date Started	Medication	Dosage	Time	Frequency	Physician	Phone #

Date/time of report	Date/time administration	Observation/Complications	Employee Recording Student Report	Parent Notification
				Date: _____ <input type="checkbox"/> Phone <input type="checkbox"/> Form
				Date: _____ <input type="checkbox"/> Phone <input type="checkbox"/> Form
				Date: _____ <input type="checkbox"/> Phone <input type="checkbox"/> Form
				Date: _____ <input type="checkbox"/> Phone <input type="checkbox"/> Form
				Date: _____ <input type="checkbox"/> Phone <input type="checkbox"/> Form
				Date: _____ <input type="checkbox"/> Phone <input type="checkbox"/> Form
				Date: _____ <input type="checkbox"/> Phone <input type="checkbox"/> Form
				Date: _____ <input type="checkbox"/> Phone <input type="checkbox"/> Form
				Date: _____ <input type="checkbox"/> Phone <input type="checkbox"/> Form

Parents/Guardian \_\_\_\_\_

Phone \_\_\_\_\_

Teacher \_\_\_\_\_

Grade \_\_\_\_\_

Dated: \_\_\_\_\_

**DIABETES MEDICAL MANAGEMENT PLAN**

**I. CONTACT AND PLAN INFORMATION**

**Student's Name:** \_\_\_\_\_ **Date of Birth:** \_\_\_\_/\_\_\_\_/\_\_\_\_  
 (Month) (Day) (Year)

**Health Condition:**     Diabetes type 1         Diabetes type 2    (For this Plan "Health Condition" means diabetes)

**Mother/Guardian:** \_\_\_\_\_

Address: \_\_\_\_\_

Telephone: Home \_\_\_\_\_ Work \_\_\_\_\_ Cell \_\_\_\_\_

**Father/Guardian:** \_\_\_\_\_

Address: \_\_\_\_\_

Telephone: Home \_\_\_\_\_ Work \_\_\_\_\_ Cell \_\_\_\_\_

**Student's Doctor/Health Care Provider:** \_\_\_\_\_

Address: \_\_\_\_\_

Telephone: \_\_\_\_\_ Emergency Number: \_\_\_\_\_

**Other Emergency Contacts:** \_\_\_\_\_

Relationship: \_\_\_\_\_

Telephone: Home \_\_\_\_\_ Work \_\_\_\_\_ Cell \_\_\_\_\_

**II. PARENT OR GUARDIAN  
 AUTHORIZATION, APPROVAL AND LIABILITY WAIVER**

The parents or guardians (hereinafter "Parent") request that Raymond Central Public Schools allow the Student to self-manage the health condition and accept and agree to this Medical Management Plan. The Guidelines for Diabetes Medical Management Plan are incorporated into and are a part of this Plan.

Parents understand and agree that if the Student injures school personnel or another student as the result of the misuse of necessary diabetes medical supplies, Parents shall be responsible for any and all costs associated with such injury. Parents acknowledge that (a) the school and its employees and agents are not liable for any injury or death arising from the Student's self-management of the Student's Health Condition and Parents release same from any such claims and (b) Parents shall and do hereby agree to indemnify and hold harmless the school and its employees and agents against any claim arising from the Student's self-management of Student's Health Condition. This release, indemnification and hold harmless agreement shall take effect immediately and shall stay in effect for as long as the Student is provided permission to self-administer medication.

Parent/guardian signature: \_\_\_\_\_ Date: \_\_\_\_\_

Parent/guardian signature: \_\_\_\_\_ Date: \_\_\_\_\_

**III. STUDENT AGREEMENT**

I will use the prescription diabetes medication only as prescribed and as permitted by the Plan. I will not share the medication with others and I will not create an unnecessary distraction to others. I have been instructed how to self-administer this medication and understand the side effects of improper use and will follow the Guidelines. I understand that if I do not abide by these terms, I may be disciplined and that this Plan will be re-evaluated. I release the school and its employees of any liability any in way related to this Plan or my use of the medication.

Student signature: \_\_\_\_\_ Date: \_\_\_\_\_

Dated: \_\_\_\_\_

**IV. MEDICAL MANAGEMENT PLAN**

**A. Health care services the Student may receive at school relating to Student's Health Condition:** See Guidelines (Part V).

**B. Evaluation of Student's understanding of and ability to self-manage Student's Health Condition.**

The parents/guardians and the Physician certify that the Student has a sufficient level of understanding and ability to self-manage the Student's Health Condition as follows:

1. Access to Prescription Diabetes Medication

- May have medication in Student's possession at any time.
- May have medication in Student's possession when the health office is not accessible (for example, when the Student is out of the school on field trips or participating in extracurricular activities) but should otherwise be maintained in the health office.
- May not have medication in Student's possession except for emergency use.

2. Self-Administration of Prescription Diabetes Medication

- May self-administer independently and without supervision. The Student has had had training and is proficient in self-administering medication.
- May self-administer when the health office or school staff authorized to administer medication are not readily accessible (for example, when the Student is out of the school on field trips or participating in extracurricular activities); but should otherwise have medication administered by the health office or authorized school staff.
- May not self-administer except for emergency use.

**C. It is agreed that this Plan permits regular monitoring of Student's self-management of Student's Health Condition by an appropriately credentialed health care professional.**

**D. Name, purpose and dosage of prescription diabetes medication prescribed for Student:** See Student Diabetes Action Plan (Part IV(F)).

**E. Procedures for storage and access to backup supplies of such prescription medication for Student's Health Condition:**

1. The Student, when permitted to be in possession of medication, will only have the prescription medication that might be needed for the Student's own use.
2. The school will store any backup supply needed in accordance with its medication storage procedures.
3. The student may have access to the backup supply when necessary by requesting such from the health office.

Dated: \_\_\_\_\_

**F. Student Diabetes Action Plan**

**Student Name:** \_\_\_\_\_ **Date of Birth:** \_\_\_\_/\_\_\_\_/\_\_\_\_  
(Month) (Day) (Year)

**EXERCISE PRECAUTION** - Should not exercise (eg, gym class, recess) if blood glucose level is below \_\_\_\_\_ mg/dl or if moderate to large urine ketones are present

<p><b><u>SUPPLIES TO BE CARRIED BY THE STUDENT</u></b> <b><u>“USE” DESCRIBES PURPOSE, WHEN TO USE &amp; AS RELEVANT, DOSAGE</u></b></p> <p>Use: _____</p> <p><input type="checkbox"/> Blood glucose meter, blood glucose test strips, batteries for meter Use: _____</p> <p><input type="checkbox"/> Lancet device, lancets, gloves, etc. Use: _____</p> <p><input type="checkbox"/> Urine ketone strips Use: _____</p> <p><input type="checkbox"/> Insulin pump and supplies Use: _____</p> <p><input type="checkbox"/> Insulin pen, pen needles, insulin cartridges Use: _____</p> <p><input type="checkbox"/> Fast-acting source of glucose Use: _____</p> <p><input type="checkbox"/> Carbohydrate containing snack Use: _____</p> <p><input type="checkbox"/> Continuous Glucose Monitor Use: _____</p> <p><input type="checkbox"/> May carry and self-administer above medications and supplies per Part IV(B) of Medical Management Plan.</p>
------------------------------------------------------------------------------------------------------------------------------------------------------------------------------------------------------------------------------------------------------------------------------------------------------------------------------------------------------------------------------------------------------------------------------------------------------------------------------------------------------------------------------------------------------------------------------------------------------------------------------------------------------------------------------------------------------------------------------------------------------------------------------------------------------------------------------------------------------------------------------------------------------------------------------------------------------------------------------------------

Possible adverse reactions to be reported to physician \_\_\_\_\_

Special instructions \_\_\_\_\_  
\_\_\_\_\_  
\_\_\_\_\_

I am the Student’s Physician. Student has diabetes and has been prescribed the medication referenced above. Student has the ability to safely and responsibly self-manage Student’s Health Condition in accordance with this Diabetes Medical Management Plan. I approve the Medical Management Plan and the Student Diabetes Action Plan and authorize Student to self-manage Student’s Health Condition at school in accordance with the Plan.

Physician signature: \_\_\_\_\_ Date: \_\_\_\_\_

Dated: \_\_\_\_\_

**V. GUIDELINES FOR  
DIABETES MEDICAL MANAGEMENT PLAN**

**Term of Plan:** The plan is effective for the current school year. A new plan must be established each school year or more often if changes occur to the student’s health or prescribed treatment or student’s ability to self-manage.

**Medications:** The parents or guardians are responsible for supplying any and all prescription diabetes medications required under the Plan; the school is not responsible for providing the medications. Prescribed diabetes medications to be used by the Student under this Plan must be furnished in a current original container from the pharmacy with the student's name and the name of the medication, and where applicable, the strength and the dosage to be given. If the prescribed medication, dosage or time of medication changes, the parents or guardians must promptly submit to the school nurse or designee the new prescription and as necessary a new diabetes action plan. Any non-prescription medication must be furnished in the original container from the manufacturer. The school will store any backup supply needed in accordance with its medication storage procedures. The student may have access to the backup supply when necessary by requesting such from the health office.

**Disposal of Medical Supplies:** The student shall be responsible for proper disposal of used syringes and other medical supplies. Used syringes and blood borne pathogen materials shall be immediately placed in a safe receptacle and properly disposed of in accordance with directions of the school health office and school administration.

**Health care services the Student may receive at school relating to Student’s Health Condition.**

1. Standard health services available to all students.
2. Storage of backup diabetes medication supplies.
3. Individual Health Plan (IHP) for diabetes management may be developed on request.

**Consultations:** The school may consult with a registered nurse or other health care professional employed by such school during development of the plan.

**Permitted Self-Management:** Pursuant to the Diabetes Medical Management Plan the Student shall be permitted to self-manage the Student’s diabetes condition in the classroom or any part of the school or on school grounds, during any school-related activity, or in any private location specified in the plan.

**Student Reports of Self-Administration:** The Student is not required to report self-administration when the Student has self-administered prescription diabetes medication pursuant to the Plan. The school health office will maintain a log of self-administration reports upon request of the parent or guardian.

**Responses to Student Misuse:** The possession of medications by Students is a violation of the school’s drug and student conduct policies and may result in an expulsion from school. To the extent this Diabetes Medical Management Plan permits the Student to be in possession of prescribed diabetes medications, the Plan allows the Student an exception to the school drug and student conduct policies. However, this exception only extends to the extent provided in the Plan. In the event the Student uses his or her prescription diabetes medication other than as prescribed, or possesses medication other than as permitted by the Plan, the Student is subject to disciplinary action by the school, up to and including an expulsion. The school will promptly notify the parent or guardian of any disciplinary action imposed. The disciplinary action will not include a limitation or restriction on the student’s access to such medication unless the school determines that the Student has endangered himself, herself, or others through the misuse or threatened misuse of such medical supplies. It is agreed that in the event of any such misuse a re-evaluation of the Student’s understanding of and ability to self-manage Student’s Health Condition will occur and the re-evaluation may result in a modification or termination of this Plan.

**Sharing Plan:** It is agreed that this Diabetes Medical Management Plan may be shared with school officials and agents who have a need to be aware of it; that those who have the need to be aware of it include student health staff and also include staff responsible for student discipline (e.g. staff need to know that the Student is authorized to have the medication on the Student’s person so the Student is not reported for a violation of the school’s drug policies). The school officials who may be informed of the Plan thus include: administration, school nurse, school office staff, teachers and any paraeducators or specialists who provide services to the Student, and the coaches and sponsors of extracurricular activities in which the Student participates.

**Filing of Plan:** This Diabetes Medical Management Plan is to be kept on file at the school where the Student is enrolled.

Diabetes Medical Management Plan for \_\_\_\_\_ (Student)

Dated: \_\_\_\_\_

**VI. SCHOOL NURSE ACKNOWLEDGEMENT OF  
DIABETES MEDICAL MANAGEMENT PLAN**

- Parent Request and Liability Waiver signed  Student Agreement signed.
- Management Plan (including Action Plan) signed by Physician.
- Guidelines reviewed with the Student and Parent/Guardian.
- Copy of Guidelines and Student Agreement received by Parent/Guardian for reference.

School Nurse or designee signature: \_\_\_\_\_ Date: \_\_\_\_\_

Diabetes Medical Management Plan for \_\_\_\_\_ (Student)

Dated: \_\_\_\_\_

**Diabetes Self-Management Log (Optional)**

Student Name \_\_\_\_\_

Student Date of Birth \_\_\_\_\_

Date Started	Medication	Dosage	Time	Frequency	Physician	Phone #

Date/time of report	Date/time administration	Observation/Complications	Employee Recording Student Report	Parent Notification
				Date: _____ <input type="checkbox"/> Phone <input type="checkbox"/> Form
				Date: _____ <input type="checkbox"/> Phone <input type="checkbox"/> Form
				Date: _____ <input type="checkbox"/> Phone <input type="checkbox"/> Form
				Date: _____ <input type="checkbox"/> Phone <input type="checkbox"/> Form
				Date: _____ <input type="checkbox"/> Phone <input type="checkbox"/> Form
				Date: _____ <input type="checkbox"/> Phone <input type="checkbox"/> Form
				Date: _____ <input type="checkbox"/> Phone <input type="checkbox"/> Form
				Date: _____ <input type="checkbox"/> Phone <input type="checkbox"/> Form
				Date: _____ <input type="checkbox"/> Phone <input type="checkbox"/> Form

Parents/Guardian \_\_\_\_\_ Phone \_\_\_\_\_

Teacher \_\_\_\_\_ Grade \_\_\_\_\_

**Seizure Safe Schools**

Each school building will have a “seizure action plan” if the following criteria are met: (1) at least one student in that building has been identified as having a seizure disorder; and (2) that student’s parent or guardian and health care provider have worked with the school to develop a seizure action plan.

Every building with a seizure action plan will have at least one employee who has met the training requirements necessary to administer or assist with the self-administration of a seizure rescue medication or medication prescribed to treat seizure disorder symptoms.

In accordance with state law, except in the case of an emergency, prior to the administration of a seizure rescue medication or medication prescribed to treat seizure disorder symptoms by a school employee, a student's parent or guardian must:

1. Provide the school with a written authorization to administer the medication at school;
2. Provide a written statement from the student's health care practitioner containing the following information:
  - a. The student's name;
  - b. The name and purpose of the medication;
  - c. The prescribed dosage;
  - d. The route of administration;
  - e. The frequency that the medication may be administered; and
  - f. The circumstances under which the medication may be administered.
3. Provide the medication to the school in its unopened, sealed package with the intact label affixed by the dispensing pharmacy; and
4. Collaborate with school employees to create a seizure action plan.

If permitted by the student's seizure action plan, a student shall be allowed to possess the supplies, equipment, and medication necessary to treat a seizure disorder in accordance with such seizure action plan.

Any authorization provided by a parent or guardian shall be effective only for the school year in which it is provided and shall be renewed each following school year.

Legal Reference: Neb. Statute 79-3201 to 3207

Date of Adoption: July 12, 2023

## Correspondence/Recognition

1. Congratulations to the Raymond Central FFA who was asked to attend the CTE Month Proclamation Signing on February 12 at the Nebraska Capitol building. The sponsor, Mrs. Donahue, and three students; Hailee Nelson - Senior, Leslie Bos -Senior, Erika Donahue -Junior attended.
2. Last week was National Counselor week, and we would like to express our gratitude to Mrs. White and Mrs. Osten for providing our students with quality opportunities and support!

## Public Forum

### Reports

### Administrative Reports

#### **Submitted by Mark Smith, Jr-Sr High School Principal**

#### **BIG PICTURE:**

A focus going into 2nd semester is to continue to employ effective instructional practices and routines. Good things are happening, and we want to continue to build on those.

Connected to this focus will be an intentional approach to making sure our students are prepared to perform well on upcoming state tests. The 6-8 staff will be doing some goal setting activities with our middle level students. We want our students to feel empowered to demonstrate what they know. The 6-8 teachers are also ensuring we take appropriate steps to review content our students will see on those assessments.

In a similar fashion, teachers of math, science, and English will incorporate ongoing review of ACT-style questions and concepts into lessons over the next couple of months. Our classes already are aligned to state standards and cover things such as reading for comprehension; writing persuasively with evidence; using graphs, charts, and tables to identify trends and patterns; and familiarity with mathematical concepts. Teachers will expose our students to ACT-style questions and provide some ACT testing prep as we get closer to the ACT test date.

By and large, the above assessment prep will be incorporated into teacher lessons when and where it aligns with our curriculum and course content. We want our students to recognize that most of what they will see on state assessments is exactly what they have been learning and doing in class throughout the year.

These big picture efforts are aligned with our school improvement goals for this year. SCHOOL

#### **IMPROVEMENT PLAN UPDATE:**

The Jr/Sr School Improvement Goals for 2023-2024 are as follows:

By the end of the 2023-2024 school year, students at Raymond Central Jr/Sr High School will demonstrate improved year-over-year academic growth by the following measures:

1. Attaining higher grade-level proficiency percentages in all subjects measured by the Nebraska Student Centered Assessment System (NSCAS), with particular focus on achieving greater proficiency in reading and math. (Grades 6-8)
  - a. 6th grade goals: >71% on spring Math NSCAS, >67% on spring ELA NSCAS
  - b. 7th grade goals: >57% on spring Math NSCAS, >38% on spring ELA NSCAS
  - c. 8th grade goals: >63% on spring Math NSCAS, >54% on spring ELA NSCAS
2. Achieving above average growth and performance targets in both reading and math scores on Measures of Academic Progress (MAP) assessments. (Grades 9-10)
3. Increasing average composite ACT scores in grade 11 by 0.5 points over previous year averages, with the long term goal of surpassing both the state and national benchmarks.

- a) Achieve school average score of 20 on ACT Math
- b) Achieve school average score of 17 on ACT ELA
- c) Achieve school average score of 20 on ACT Science

**Submitted by Tony Kobza, Asst Jr-Sr High School Principal/Athletic Director**

The discus ring was poured in the end of December. Great timing by Jared to get it done before the snow delays would have altered plans. In the Spring of 2025 we will be able to have discus and shot put near each other to assist with practice and events.

Stage and wall mats quotes have been received and we are moving forward to update those.

We have a quote to put in new basketball hoops and masts that will be part of the gym upgrades with shot clock and LED lights behind backboard. Current backboards are not standard size.

We are looking at options to add water to the new practice field area for watering and hydration.

Finally, we are working to replace/repair the mats on the front of the stage as they are showing some dramatic wear and tear. We are waiting on a quote for repair as well as information on whether the current mats are covered through a warranty.

**Submitted by Steve Rose, Elementary Principal and Deb Kruse, Assistant Elementary Principal**  
**Elementary Campus School Improvement Update**

**2023-24 Elementary Goal**

80% or more of students will meet or exceed benchmark goals in reading by the end of the 2023-24 school year. Each student will improve in applicable reading skills to include: phonological awareness, phonics, fluency, vocabulary, and reading comprehension.

**Action Steps:**

1. Each Teacher will develop a Personal Development Plan related to the District Goals.
2. Develop a MTSS structure to support all tiers in the academic area.
  - a. Develop and Implement School-wide expectations / Common Language
  - b. Develop and Implement MTSS-B teams to explore student data and make informed decisions
3. Implementation of new ELA Curriculum
  - a. PD Centered around Implementation of Wit & Wisdom and Orton Gillingham
4. Active Participation
5. Classroom Culture
  - a. Training and Development of Tier 1 beliefs and strategies centered around classroom climate and culture

**Strategies and Progress Towards Action Steps**

**Action Step 1:** Each teacher created a SMART goal to address specific areas of growth (phonological awareness, phonics, fluency, vocabulary, reading comprehension) All teachers are collecting data towards that goal using Orton Gillingham Assessments, NSCAS Data, and FastBridge Data

**Action Step 2:** The schools are in the process of building capacity in our MTSS-B and Mental Health Teams. All Elementary Teachers are working through Classroom Culture Training delivered by Mike Feit from the ESU.

We are also sending representatives from the elementary to work on Mental Health Boot Camp Trainings at the ESU to discuss processes in place for screening the Social Emotional Health of our students. Through that process all classroom teachers have completed the Student Risk Screening Scale (SRSS) on all students to gain insight into students who may be at higher risk for anti-social behavior patterns and put plans in place to support those students.

Our MTSS-B team tracks student minor and major behaviors and works with teachers to layer up supports.

The teacher leadership team has been integral in implementing the School-wide Expectations which provides common language and expectations for all students and adults in all buildings.

**Action Step 3:** The implementation and continued professional development around our new English Language Arts curriculum has continued with a large amount of training being completed during the Summer of 2023 by all of our classroom teachers as well as our Special Education teachers and Reading specialists. Orton Gillingham was completed as a 5 day, 6 hour per day training that set our teachers up for success as they implemented this Foundational Skills curriculum in our K-5 classrooms. The teachers also spent several days before the start of the school year to train and prepare themselves for implementation of the Wit & Wisdom. Professional Development time has been and will continue to be allocated to continue developing the delivery of instruction in ELA Wit & Wisdom by allowing co-planning as well as grade and vertical conversations around the scope and sequence of skills within the program and how it we can continue to improve on the instructional practices of the teachers.

**Action Step 4:** We have continued to promote and instruct on the importance of 100% Active Participation that was introduced during the 2022-2023 school year. The administration has continued to notice growth in this area during our classroom walk-throughs and informal / formal observations. Our teachers have excelled in making sure that all students are responsible for content related responses and will keep working to make sure that is ingrained into all lessons.

**Action Step 5:** Throughout the year our teachers have been taking a course on Classroom Culture from Mike Feit (ESU2). The sessions completed so far have focused on teachers providing a consistent and calm behavior in the classroom, creating sustainable routines and procedures to help students navigate the daily ins and outs of the classroom, and providing our first and most attention to the positive behaviors or best conduct of students within the classroom.

**Progress:** We have seen significant growth in student data related to our foundational skills from the beginning of the year to the middle of the year checkpoints in the area of English Language Arts. An example of this growth is evidenced by the following charts:

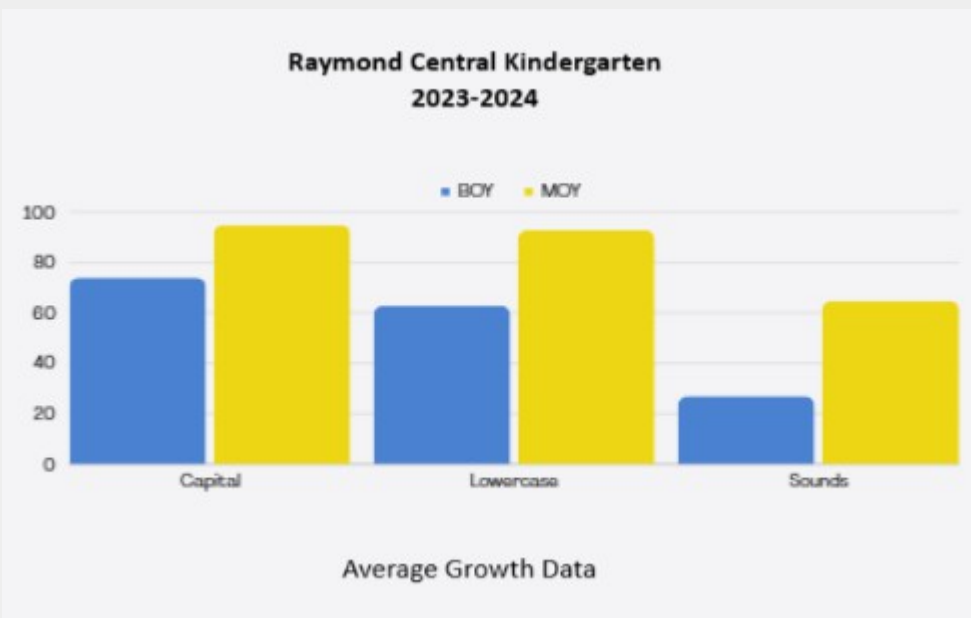
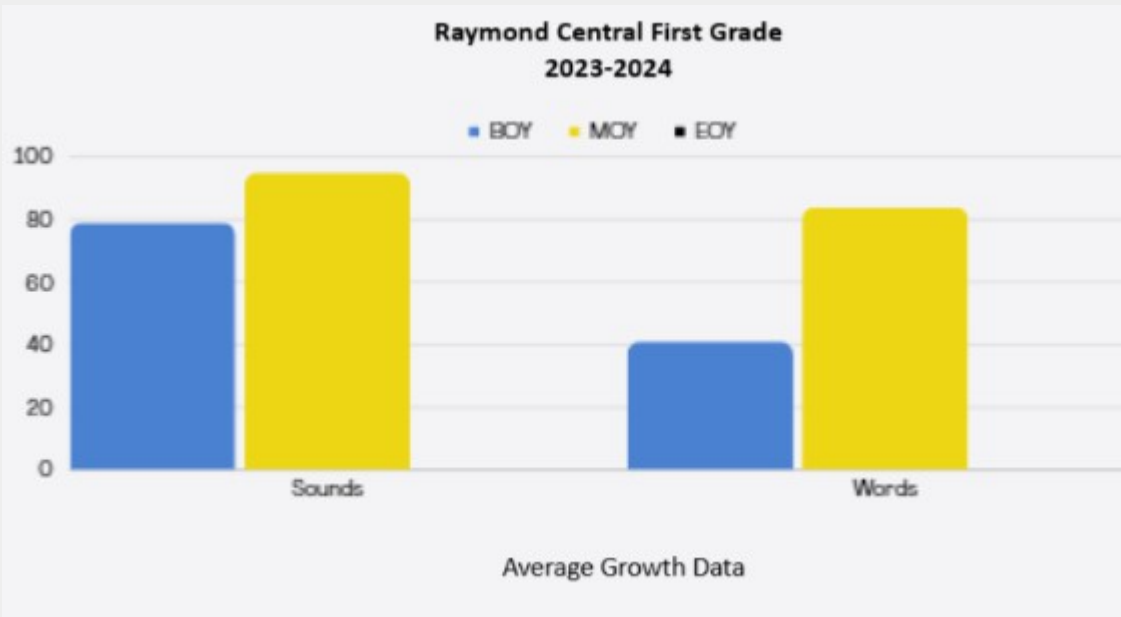

Areas that we are working on adding additional structures and support are creating a toolbox for interventions, training for paraprofessionals in interventions and classroom support, and formalizing

our referral process for Student Assistance Teams (SAT) and how that is incorporated within the MTSS-A umbrella.

### **Professional Development**

**Report Cards:** A team of teachers along with support from ESU will be working to update and refine the Elementary Report Card. The current report card is outdated and not conducive to informing parents and teachers of the relevant information when it comes to student performance towards our standards. The report card change will be completed and ready to implement for the 2024-2025 school year.

**Instructional Model:** The K-12 administrative team has put together a 3-year professional development plan based on the RC Instructional Model. The RC Instructional Model and professional development plan was developed based on teacher feedback, walkthroughs, observations, student performance data, and perception surveys.

The RC Instructional model is based on the science of learning and scientifically research-based strategies. This is useful to classroom teachers because it presents a research-based rationale for why and when certain instructional strategies should be considered. The more teachers know about how the brain learns, the greater the number of instructional options that become available. Increasing the options that teachers have during the process of instruction also increases the likelihood that successful learning will occur.

On December 8, 2023, a team of K-12 teachers and administrators met to ensure the RC Instructional Model is reflected in the Teacher Performance and Evaluation Framework. This team of teachers have agreed to be part of our professional development team for the next three years. They will co-present professional development around the RC Instructional Model. To prepare, this team will participate in book studies, complete an online course on the phases of learning, attend a 2-day summer training, led by administration, and meet periodically throughout the school year. We are excited to have this team share their expertise and experience with the rest of the staff.

#### **Members of the PD Team:**

K-12 administrators

Hannah Kring - 1st Valparaiso

Kathleen Cooper - 5th Valparaiso

Kim Hudson - 2nd Ceresco

Monica Blank - Title / Coach Ceresco

Nicole Kliment - Special Education / Valparaiso

Rebecca Parks - Family and Consumer Science / Secondary School

Andrew Placke - Social Studies / Secondary School

Jill Huck - English Language Arts / Middle School

#### **Submitted by Amanda Coufal, Director of Special Education**

#### **Targeted Improvement Plan (TIP):**

On January 29, Caitlin Roussan and I attended the TIP workshop at ESU2. This was a beneficial workshop as they gave us many resources to use when writing our targeted improvement plan for the special education department. We changed our goal this year to reflect the work that the district is doing in regard to reading. The Targeted Improvement Plan goal for Raymond Central Public Schools

is: 40% of special education students in grades second through fifth grade will be proficient on the FastBridge Reading Assessments. Current numbers based on the 2022-2023 Fall FastBridge assessment yield 26% of identified students at or above proficiency level.

Continued professional development will occur in the area of active participation for staff in the school years of 2022-2025. Staff will be trained in the Science of Learning and scientifically researched strategies for each learning phase. They will also receive professional development on instructional strategies for special needs students.

**Orton-Gillingham Training for Paraeducators:**

Deb Kruse and I have asked four paraeducators to be trained in OG and hopefully, more can be trained in upcoming years. Paraeducators will learn the protocols in OG+ (three part drill, vowel intensive, word and sentence dictation, decodable readers, red words and syllabication).

After the training, paraeducators can easily support any protocol that teachers are using in the classroom and have the materials they need to do additional practice. They will learn how to adjust their card deck and practice based on student difficulties, so they can make adjustments. They will learn how to work with the classroom teacher to determine best support for students and how the para can build on what the classroom teacher is doing. Paraeducators are very excited to start this work and to be able to intensify reading strategies for struggling learners.

## **Elementary Campus School Improvement Update**

### **2023-24 Elementary Goal**

**80% or more of students will meet or exceed benchmark goals in reading by the end of the 2023-24 school year. Each student will improve in applicable reading skills to include: phonological awareness, phonics, fluency, vocabulary, and reading comprehension.**

#### **Action Steps:**

- 1) Each Teacher will develop a Personal Development Plan related to the District Goals.
- 2) Develop a MTSS structure to support all tiers in the academic area.
  - a) Develop and Implement School-wide expectations / Common Language
  - b) Develop and Implement MTSS-B teams to explore student data and make informed decisions
- 3) Implementation of new ELA Curriculum
  - a) PD Centered around Implementation of Wit & Wisdom and Orton Gillingham
- 4) Active Participation
- 5) Classroom Culture
  - a) Training and Development of Tier 1 beliefs and strategies centered around classroom climate and culture

#### **Strategies and Progress Towards Action Steps:**

##### **Action Step 1:**

Each teacher created a SMART goal to address specific areas of growth (phonological awareness, phonics, fluency, vocabulary, reading comprehension) All teachers are collecting data towards that goal using Orton Gillingham Assessments, NSCAS Data, and FastBridge Data

##### **Action Step 2:**

The schools are in the process of building capacity in our MTSS-B and Mental Health Teams. All Elementary Teachers are working through Classroom Culture Training delivered by Mike Feit from the ESU.

We are also sending representatives from the elementary to work on Mental Health Boot Camp Trainings at the ESU to discuss processes in place for screening the Social Emotional Health of our students. Through that process all classroom teachers have completed the Student Risk Screening Scale (SRSS) on all students to gain insight into students who may be at higher risk for anti-social behavior patterns and put plans in place to support those students.

Our MTSS-B team tracks student minor and major behaviors and works with teachers to layer up supports.

The teacher leadership team has been integral in implementing the School-wide Expectations which provides common language and expectations for all students and adults in all buildings.

**Action Step 3:**

The implementation and continued professional development around our new English Language Arts curriculum has continued with a large amount of training being completed during the Summer of 2023 by all of our classroom teachers as well as our Special Education teachers and Reading specialists. Orton Gillingham was completed as a 5 day, 6 hour per day training that set our teachers up for success as they implemented this Foundational Skills curriculum in our K-5 classrooms. The teachers also spent several days before the start of the school year to train and prepare themselves for implementation of the Wit & Wisdom. Professional Development time has been and will continue to be allocated to continue developing the delivery of instruction in ELA Wit & Wisdom by allowing co-planning as well as grade and vertical conversations around the scope and sequence of skills within the program and how it we can continue to improve on the instructional practices of the teachers.

**Action Step 4:**

We have continued to promote and instruct on the importance of 100% Active Participation that was introduced during the 2022-2023 school year. The administration has continued to notice growth in this area during our classroom walk-throughs and informal / formal observations. Our teachers have excelled in making sure that all students are responsible for content related responses and will keep working to make sure that is ingrained into all lessons.

**Action Step 5:**

Throughout the year our teachers have been taking a course on Classroom Culture from Mike Feit (ESU2). The sessions completed so far have focused on teachers providing a consistent and calm behavior in the classroom, creating sustainable routines and procedures to help students navigate the daily ins and outs of the classroom, and providing our first and most attention to the positive behaviors or best conduct of students within the classroom.

**Progress:**

We have seen significant growth in student data related to our foundational skills from the beginning of the year to the middle of the year checkpoints in the area of English Language Arts. An example of this growth is evidenced by the following charts:

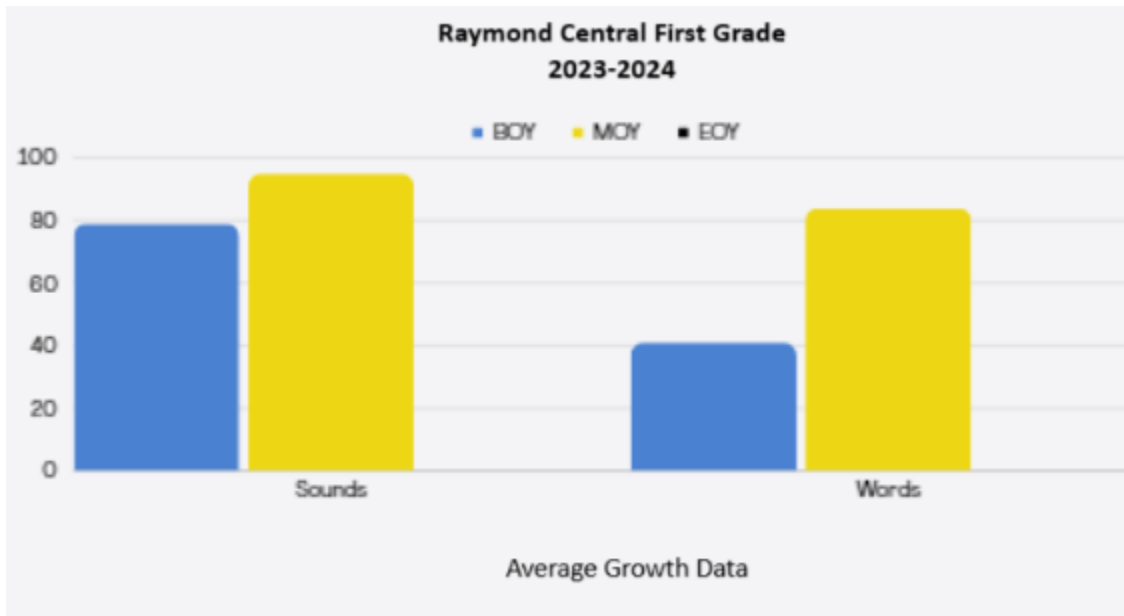
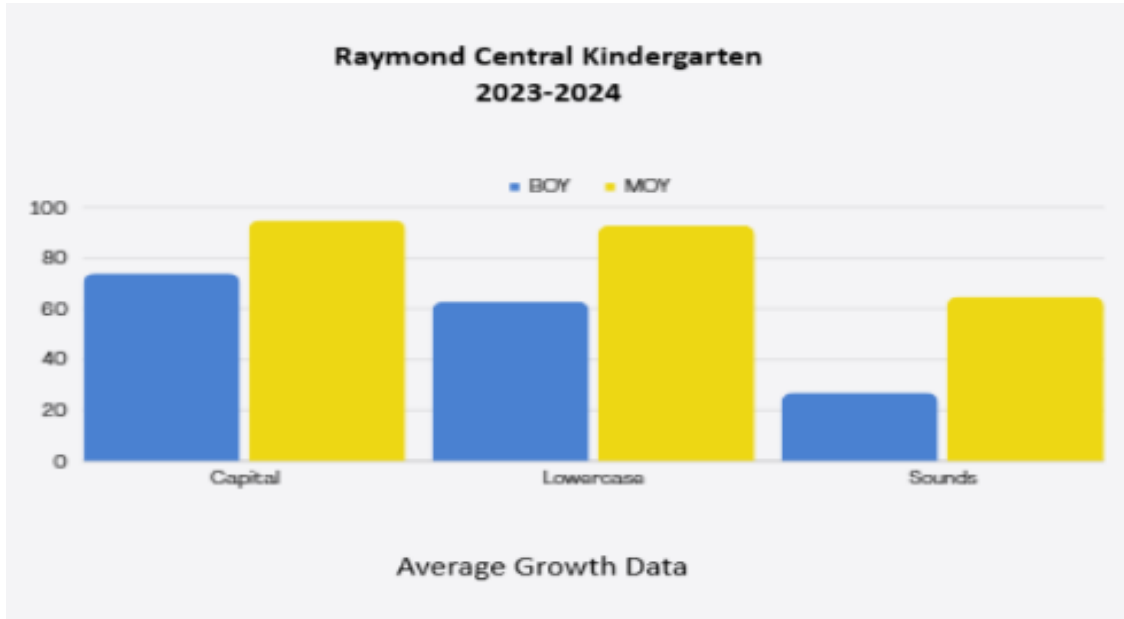

Areas that we are working on adding additional structures and support are creating a toolbox for interventions, training for paraprofessionals in interventions and classroom support, and formalizing our referral process for Student Assistance Teams (SAT) and how that is incorporated within the MTSS-A umbrella.

### **Professional Development**

#### **Report Cards:**

A team of teachers along with support from ESU will be working to update and refine the Elementary Report Card. The current report card is outdated and not conducive to informing

parents and teachers of the relevant information when it comes to student performance towards our standards. The report card change will be completed and ready to implement for the 2024-2025 school year.

### **Instructional Model:**

The K-12 administrative team has put together a 3-year professional development plan based on the RC Instructional Model. The RC Instructional Model and professional development plan was developed based on teacher feedback, walkthroughs, observations, student performance data, and perception surveys.

The RC Instructional model is based on the science of learning and scientifically research-based strategies. This is useful to classroom teachers because it presents a research-based rationale for why and when certain instructional strategies should be considered. The more teachers know about how the brain learns, the greater the number of instructional options that become available. Increasing the options that teachers have during the process of instruction also increases the likelihood that successful learning will occur.

On December 8, 2023, a team of K-12 teachers and administrators met to ensure the RC Instructional Model is reflected in the Teacher Performance and Evaluation Framework. This team of teachers have agreed to be part of our professional development team for the next three years. They will co-present professional development around the RC Instructional Model. To prepare, this team will participate in book studies, complete an online course on the phases of learning, attend a 2-day summer training, led by administration, and meet periodically throughout the school year. We are excited to have this team share their expertise and experience with the rest of the staff.

### **Members of the PD Team:**

K-12 administrators

Hannah Kring - 1st Valparaiso

Kathleen Cooper - 5th Valparaiso

Kim Hudson - 2nd Ceresco

Monica Blank - Title / Coach Ceresco

Nicole Kliment - Special Education / Valparaiso

Rebecca Parks - Family and Consumer Science / Secondary School

Andrew Placke - Social Studies / Secondary School

Jill Huck - English Language Arts / Middle School

## RC JR/SR HIGH PRINCIPAL REPORT – 2.03.2023

### BIG PICTURE:

A focus going into 2nd semester is to continue to employ effective instructional practices and routines. Good things are happening, and we want to continue to build on those.

Connected to this focus will be an intentional approach to making sure our students are prepared to perform well on upcoming state tests. The 6-8 staff will be doing some goal setting activities with our middle level students. We want our students to feel empowered to demonstrate what they know. The 6-8 teachers are also ensuring we take appropriate steps to review content our students will see on those assessments.

In a similar fashion, teachers of math, science, and English will incorporate ongoing review of ACT-style questions and concepts into lessons over the next couple of months. Our classes already are aligned to state standards and cover things such as reading for comprehension; writing persuasively with evidence; using graphs, charts, and tables to identify trends and patterns; and familiarity with mathematical concepts. Teachers will expose our students to ACT-style questions, and provide some ACT testing prep as we get closer to the ACT test date.

By and large, the above assessment prep will be incorporated into teacher lessons when and where it aligns with our curriculum and course content. We want our students to recognize that most of what they will see on state assessments is exactly what they have been learning and doing in class throughout the year.

These big picture efforts are aligned with our school improvement goals for this year.

### SCHOOL IMPROVEMENT PLAN UPDATE::

The Jr/Sr School Improvement Goals for 2023-2024 are as follows:

**By the end of the 2023-2024 school year, students at Raymond Central Jr/Sr High School will demonstrate improved year-over-year academic growth by the following measures:**

- 1. Attaining higher grade-level proficiency percentages in all subjects measured by the Nebraska Student Centered Assessment System (NSCAS), with particular focus on achieving greater proficiency in reading and math. (Grades 6-8)**
  - a. 6th grade goals: >71% on spring Math NSCAS, >67% on spring ELA NSCAS**
  - b. 7th grade goals: >57% on spring Math NSCAS, >38% on spring ELA NSCAS**
  - c. 8th grade goals: >63% on spring Math NSCAS, >54% on spring ELA NSCAS**
- 2. Achieving above average growth and performance targets in both reading and math scores on Measures of Academic Progress (MAP) assessments. (Grades 9-10)**
- 3. Increasing average composite ACT scores in grade 11 by 0.5 points over previous year averages, with the long term goal of surpassing both the state and national benchmarks.**
  - a. Achieve school average score of 20 on ACT Math**
  - b. Achieve school average score of 17 on ACT ELA**
  - c. Achieve school average score of 20 on ACT Science**

The measurable goal outcomes are tied to various assessments that will take place later this spring. We will not have our final results until the end of the school year, or even into next fall.

We do have some action steps in place that are intended to get us to these goals. The actions steps are:

- 1) Each Teacher will develop a Personal Development Plan related to the District Goals.
- 2) Develop a MTSS structure to increase support for all tiers in both academic and behavioral areas.
  - a) Develop and Implement School-wide expectations / Common Language.
  - b) Develop and Implement MTSS teacher teams to explore student data and make informed decisions.
- 3) Implementation of new 6-8 ELA Curriculum.
- 4) Professional Development for staff on 100% Active Participation.
- 5) Classroom Culture
  - a) Training and Development of Tier 1 beliefs and strategies centered around classroom climate and culture.
  - b) Intentional focus of key cognitive development skills and traits through Cloud9.

Progress is being made on all of these action steps.

- 1) To date, all 6-12 teachers have developed growth goals aligned with increasing active engagement in the classroom. These goals are the basis of feedback given to teachers when instruction is observed in their classrooms. We also take time for teachers to reflect on these goals during professional development sessions throughout the year.
- 2) School wide expectations are visible and utilized. Students are familiar with common language around academic and behavioral expectations. The MTSS teacher teams have been meeting weekly to identify areas of concern, and to implement interventions.
- 3) The 6-8 curriculum has been in place since the start of school. 6-8 ELA teachers continue to use time on PD days to plan and evaluate the use of this new curriculum.
- 4) Professional development focused on active participation classrooms is ongoing. During 2nd semester, we will utilize some before- and after-school staff meetings to specifically reflect and share how those efforts are impacting students.
- 5) Classroom culture training is ongoing for staff on professional development days. We are continuing to utilize Cloud9 to help students think and reflect on positive cognitive development skills (hope, initiative, growth mindset, etc.).

I am confident that these action steps are helping us move our students forward in ways that will allow us to meet the measurable objectives on our school improvement goals.

#### INSTRUCTIONAL PRACTICE:

Teachers participated in a remote PD day on Jan. 15. We spent that time reflecting on effective hinge questions that allow us to check for understanding in the midst of instruction. Teachers took time to develop thoughtful hinge questions to use in upcoming lessons. We took time on Feb. 7 to share the use of the hinge questions as a staff.

[Jan. 15 PD Slides](#)

STAFFING:

- Interviews have been held to fill our 7-12 PE/Health position for 24-25.
- Interviews have been held for our middle school math position for 24-25.

February 2024 AD Board Report  
Mr. Tony Kobza  
Assistant Principal/AD

### **AD Newsletter**

Here are the links to our weekly newsletter laying out the upcoming events as well as the successes from the previous week. Please take a look at them below with more in depth information:

[1/15/24](#)

[1/21/24](#)

[1/28/24](#)

[2/4/24](#)

### **Facilities**

The discus ring was poured in the end of December. Great timing by Jared to get it done before the snow delays would have altered plans. In the Spring of 2025 we will be able to have discus and shot put near each other to assist with practice and events.

Stage and Wall mats quotes have been received and we are moving forward to update those.

We have a quote to put in new basketball hoops and masts that will be part of the gym upgrades with shot clock and LED lights behind backboard. Current backboards are not standard size.

We are looking at options to add water to the new practice field area for watering and hydration.

Finally, we are working to replace/repair the mats on the front of the stage as they are showing some dramatic wear and tear. We are waiting on a quote for repair as well as information on whether the current mats are covered through a warranty.

SpEd Board Report - February  
Mrs. Amanda Coufal  
Director of Special Education

**Targeted Improvement Plan (TIP):**

On January 29th, Caitlin Roussan and I attended the TIP workshop at ESU2. This was a beneficial workshop as they gave us many resources to use when writing our targeted improvement plan for the special education department. We changed our goal this year to reflect the work that the district is doing in regard to reading. The Targeted Improvement Plan goal for Raymond Central Public Schools is: 40% of special education students in grades second through fifth grade will be proficient on the FastBridge Reading Assessments. Current numbers based on the 2022-2023 Fall FastBridge assessment yield 26% of identified students at or above proficiency level.

Continued professional development will occur in the area of active participation for staff in the school years of 2022-2025. Staff will be trained in the Science of Learning and scientifically researched strategies for each learning phase. They will also receive professional development on instructional strategies for special needs students.

**Orton-Gillingham Training for Paraeducators:**

Deb Kruse and I have asked four paraeducators to be trained in OG and hopefully, more can be trained in upcoming years. Paraeducators will learn the protocols in OG+ (three part drill, vowel intensive, word and sentence dictation, decodable readers, red words and syllabication). After the training, paraeducators can easily support any protocol that teachers are using in the classroom and have the materials they need to do additional practice. They will learn how to adjust their card deck and practice based on student difficulties, so they can make adjustments. They will learn how to work with the classroom teacher to determine best support for students and how the para can build on what the classroom teacher is doing. Paraeducators are very excited to start this work and to be able to intensify reading strategies for struggling learners.



Student Board Member

**Submitted by Rosalie Tvrdy, Student Body President**

Hello, and happy February! It is crazy to believe that we are already into the second month of 2024. Even with all of the snow days that we had at the beginning of January, it seems that our extracurriculars and activities have been keeping busy. Like I have said in the past, being involved in a lot of activities here has allowed me to share a lot of the great things that our students are doing. Within our FBLA chapter, we hosted a good will donation soup supper on the night of the rescheduled David City versus RC basketball games. We had many people come, and it was a great fundraising event for our chapter. Even the superintendent from David City had come and told us members how grateful he was to have some soup to eat, rather than having more concession food. He had said he was at a wrestling meet earlier that day, and then was going to come to the basketball game at RC that night, and he was dreading having more concession food, but when he heard we were having a soup supper, he was very happy and thankful. Also that night, FBLA was able to sell some of the shirts that we have made with our new T-shirt press. With our new T-shirt press, we have been able to make our own chapter T-shirts, and start a school-based enterprise, which has allowed us the chance to win many awards at the State Leadership Conference. This also allows us to showcase more activities within our chapter's end-of-year report. We have many members preparing for the State Leadership Conference in April. Members have been submitting projects, attending study nights, and working very hard to achieve success at the competition.

The high school student council has also been working hard to publicize our blood drive that is happening on February 29. If we can get enough donors, the seniors on the student council have a chance to get a scholarship from the blood bank.

Hello, and happy February! It is crazy to believe that we are already into the second month of 2024. Even with all of the snow days that we had at the beginning of January, it seems that our extracurriculars and activities have been keeping busy. Like I have said in the past, being involved in a lot of activities here has allowed me to share a lot of the great things that our students are doing. Within our FBLA chapter, we hosted a good will donation soup supper on the night of the rescheduled David City versus RC basketball games. We had many people come, and it was a great fundraising event for our chapter. Even the superintendent from David City had come and told us members how grateful he was to have some soup to eat, rather than having more concession food. He had said he was at a wrestling meet earlier that day, and then was going to come to the basketball game at RC that night, and he was dreading having more concession food, but when he heard we were having a soup supper, he was very happy and thankful. Also that night, FBLA was able to sell some of the shirts that we have made with our new T-shirt press. With our new T-shirt press, we have been able to make our own chapter T-shirts, and start a school-based enterprise, which has allowed us the chance to win many awards at the State Leadership Conference. This also allows us to showcase more activities within our chapter's end-of-year report. We have many members preparing for the State Leadership Conference in April. Members have been submitting projects, attending study nights, and working very hard to achieve success at the competition.

The high school student council has also been working hard to publicize our blood drive that is happening on February 29th. If we can get enough donors, the seniors on the student council have a chance to get a scholarship from the blood bank.

Student council members have been reading fun facts about blood donations over the announcements in the mornings, and they have been making sure to let other students know about the blood drive as well.

## Superintendent's Report

4. The district realized \$6,163 from the items that we sold online with Big Iron. We are pleased with the result.
5. The district is reviewing a variety of food service programs. The program that we are currently using doesn't offer all of the features we would like and they are discontinuing some of the features that we do like. We intend to find a different program to have in place next school year.
6. ESU#2 is working collaboratively with the schools within the unit to review new online credit recovery programs. We are currently using APEX but are looking for a better option. Once the vendor of choice is identified by ESU#2, then we can evaluate whether it is the best vendor for our needs.
7. Policy 6112 - School Day for Students. The committee had discussions regarding establishing/maintaining a climate where students have opportunities to receive individual assistance from teachers outside the regular school day.

Aug 2020

# 1323.34

NPERS Retirement Plan Employer Final Audit Report

FFA Sponsor  
+ Sub Driver



NEBRASKA PUBLIC EMPLOYEES RETIREMENT SYSTEMS

# Final Audit Report

## Retirement Participation & Reporting Procedures

**Raymond Central Public Schools - Org #02-161**

**July 1, 2022 through June 30, 2023**

**Report issued on: December 18, 2023**

### DISTRIBUTION

FROM: Cassie Snyder, NPERS Auditor  
Vanessa Hohlen, Internal Audit Manager

TO: Lynn Johnson, Superintendent  
Cheryl Rieck, Reporting Agent  
Peggy Breitreutz, Reporting Agent

## OPINION AND FINDINGS

The findings represent a sample of current employees and are based on information provided during our audit. This audit is not intended to identify all deficiencies or weaknesses. If Raymond Central Public Schools disagrees with any audit finding noted, please submit supporting documentation.

### No issues noted in the following:

- Internal Controls
- Demographic and Employment Information

### Findings:

#### Member Eligibility

**One non-contributing employee (Paul Hass) was eligible upon re-hire.**

An employee who had previously met eligibility for the plan at your school district is required to continue plan participation if:

1. They are re-hired by your school district in a regular capacity (non-substitute, non-temporary)
2. They continue to have an account balance with NPERS.

Adjustments will be needed to make-up missing contributions for Paul Hass from rehire to current.

[See Action Plan D1]

#### Bona Fide Termination Violations

**One employee rendered over 8 days of service from her termination date:**

Rhonda Madsen had a termination date of May 16, 2022. In the 180 days after her termination date, she worked over 8 days of substitute service in several calendar months while also working as an activity driver. When a member terminates regular employment and stops contributions, they must have 180 days of separation from service with 8 days or less of only substitute or volunteer service in a calendar month in order to have a “bona-fide termination”. Because of the termination violation, she had missing contributions from August 2022 through May 2023. When NPERS collected the information from the school and estimated the recalculated benefit, we found that because of the inconsistent reporting (going from an annualized salary to being paid on a month-by-month basis), the member’s benefit would be reduced. In a meeting with the NPERS Director, he determined that it would be “unreasonable” for the school to make-up contributions as the benefit recalculation falls within NPERS Rules and Regulations.

NAC 303, Chapter 14 004.01 A member’s retirement benefit is not to be enhanced or reduced solely as a result of (1) inconsistent timing in the payment or reporting of compensation by the member’s employer or (2) an irregular work schedule.

In this instance, Rhonda’s benefit will NOT be re-calculated and we WILL NOT require the school to make-up contributions. Because the employer is responsible to pay both employee and employer missed contributions, the school should track all service rendered after termination from regular employment

**Extra duty wages were reported year-round, while service is only rendered part of the year:**

If extra duty wages are reported when they are not earned, it causes ineligible compensation to be reported during the months service is not rendered resulting in excess contributions and it causes eligible compensation to be omitted when service is actually rendered resulting in insufficient contributions.

**Extra duty hours and wages need to be reported when worked/earned.** Adequate documentation must be maintained to support the schools reporting of service credit compensation, and contributions to NPERS. Inaccurate and improper reporting can have material effects on a member's benefits.

Our standard guidance for all on how to proceed with adhering to this is the following:

- Consider changing master negotiated agreements to pay extra duty wages when earned to allow for a payroll change, OR
- Submit an adjustment report at the end of the contract year to move the extra duty wages/hours to the month(s) in which they were earned/worked. For more information on submitting an adjustment report, please refer to the Employer Reporting Manual.

**Response to Questionnaire:**

**Question A-4: When an employee has a name change, do you document the name change was legal by obtaining a copy of the social security card? The response was, "No"**

Employee names on reports submitted to NPERS should be the legal name from their Social Security card. Employers should have documentation of a name change prior to changing the name on their monthly contribution reports. Documentation should be kept on file to be able to provide source documentation to NPERS for the name change.

**Question A-10 For past employees who are returning to your school in a non-substitute position, do you verify if the employee has a NPERS account balance in verifying eligibility? The response was, "Yes, all new hires receive the Beneficiary Designation & application for Vesting Credit forms to complete."**

At every new hire/rehire, the Vesting Credit Application form should be given, but it would not identify whether a rehired employee has an account balance with NPERS. The rehired employee should be asked if they still have an account balance. If the rehired employee is uncertain of their account status, they can call our Member Services department to verify their account status.

An employee who has terminated employment with your school district, continues to have an account balance with NPERS, and returns to employment with your school district providing any regular (non-substitute/non-temporary) service, must commence retirement contributions at the time the regular service is provided. The employee does not need to meet the hour requirement to be determined eligible for the retirement plan.

## **Response to School Employer Questionnaire:**

### **Enrollment of Employees in NPERS**

**Question A-1:** Does your school provide a School Retirement Plan Handbook and Beneficiary Designation form to, and inform all eligible hires and re-hire of, their mandatory participation and evaluate employee participation eligibility at the time of hiring based on Nebraska Statute 79-902? *The response was, “Sometimes—most of the time.”*

Per the School Manual for Reporting Agents: You should provide a “[New Plan Member Welcome Packet](#)” to all new employees and re-hires. An electronic version of this packet is available on the NPERS website on the School Plan page. For employees who do not have internet access, please assemble a “packet” that includes the publications listed below: School Retirement Plan Handbook, Beneficiary Designation Form, and the Application for Vesting Credit Form.

It is imperative to provide the School Retirement Plan Handbook to every member upon hire/rehire in order to ensure the member has the education they need for their retirement plan.

It is imperative to provide the Beneficiary Designation Form to every member upon hire/rehire to ensure the member has every opportunity to update their beneficiaries and reduce the length of processing time for benefit payments, simplify processes internally for NPERS, help avoid probate issues, and generally provide a more calm and clear experience for the member’s loved ones.

**Question A7 & A7(a):** Does your school track hours worked for all non-contributing employees including employees who only provide extra duties or seasonal employment per calendar month in the fiscal year? If yes, please describe your monitoring process. *The response was, “Sometimes. We use timesheets to monitor hourly employees”*

In response that the employer “sometimes” tracks hours worked, all hours must be tracked at the time they are worked for both hourly and salaried employees. Even if the employee is a salaried part-time employee, the hours need to be tracked to ensure the employee is enrolled if the threshold for mandatory participation is initiated based on working an average of 20 or more hours a week in any 3 calendar months of a plan year (July 1 – June 30).

Retirement eligibility is based on how many hours an employee works during a calendar month. Unless an employee is a true substitute (does not have regular/ongoing full or part-time employment relationship and only provides service on a temporary, irregular basis to fill in for temporarily absent employees) or a temporary employee (hired on to provide service for a limited period of time, not to exceed one year, and when the task is complete, the employment is terminated), all hours must be tracked to determine eligibility, to include employees who solely provide extra duties. Not monitoring hours puts the employee at risk of not being enrolled in the

that indicates a violation, a new 180-day separation period must begin and an adjustment form must be completed for services rendered **at your school** to make-up compensation, contributions, and service credit from termination to the date of violation.

## **Processes:**

### **Making adjustments:**

1. Fill out the School Adjustment Report and forward it to NPERS via fax or mail.
2. NPERS will check to make sure the values you had previously reported match what is on the form and that everything else is filled out correctly.
3. Ensure you mark the box to indicate the adjustment is due to an audit. This form will serve as source documentation for the manual adjustments you will make.
4. Make sure to enter the adjustments as a part of the next available monthly report submitted. The space on the adjustment form “Submitted via the web on the \_\_\_\_\_ Wage and Contribution Report” is where to let us know what submitted report the adjustments will be on.
5. These are manual entries that need to be added after the report has uploaded, but before you confirm the report.
6. NPERS reviews the adjustment entries and confirm they are correct on an individual and aggregate basis.

The School Adjustment Report form link is provided below. The form (NPERS6200) will need to be completed with the adjustment entries added to the report. Page 6-48 of the School Manual for Employer Contacts explains how to fill in the form and the instructions for entering the adjustments to the report start on page 6-51. The report will need to be completed by the school and sent back to NPERS with a signature and explanation.

<https://npers.ne.gov/SelfService/public/forms/employerReporting/AdjustmentReport.pdf>

School Manual for Employer Contacts:

<https://npers.ne.gov/SelfService/public/documentation/employerReporting/school/SchoolERMan.pdf>

## Nebraska Public Retirement Systems Corrective Action Plan for Audit Finding

Org #: 02-161 School: Raymond Central

Corrective Action Plan Information:	
<b>Audit Category:</b>	Reporting of Extra Duty Wages & Hours
<b>Audit Action Item:</b>	Adjustment
<b>Finding:</b>	One non-contributing employee (Paul Hass) was eligible upon re-hire.
<b>Corrective Action Taken or To Be Taken:</b>	Adjustments needed from re-hire to current date/ <i>date of end of service.</i>
If already taken, date of completion:	
If to be taken, estimated date of completion:	January 2024
<b>Employer Contact Responsible:</b>	Cheryl Rieck
Phone number:	
Email:	
<b>NPERS Additional Comments:</b>	N/A
<b>Employer Response:</b>	<i>We understand the requirements and recognize the need to correct.</i>
Does the employer agree with the finding?	Yes <input checked="" type="checkbox"/> No <input type="checkbox"/> Partially <input type="checkbox"/>
If partially, explain:	
Employer Signature/Title	<i>Lynn M. Johnson, Superintendent</i>

Submit completed form electronically to:

**NPERS Auditor:**

Cassie Snyder

All members with comparable reporting issues must be corrected as well.

Notification of classified staff hires/reassignment/resignations

Adison Kenning will remain as a middle school teacher but he will be doing predominantly math at the 6-8 grade levels.

NASB Monthly Update

**MEMBERSHIP DUES INVOICE**

in account with

**Nebraska Association of School Boards**

1311 Stockwell, Lincoln, NE 68502 (402) 423-4951 or 1-(800) 422-4572

**Name:** Raymond Central Public Schools**County:** Lancaster**NASB Region:** 10

<b>DATE</b>	<b>DESCRIPTION</b>	<b>AMOUNT DUE</b>
January 27, 2024	<b>Annual Membership Dues</b> for NASB Fiscal Year 4/1/24 to 3/31/25	\$5130
	All districts/ESU's who pay dues by 4/1/24 may subtract 2% from their total dues.	\$103
	<b>TOTAL AMOUNT DUE IF PAID BY APRIL 1, 2024</b>	<b>\$5027</b>

Thank you for your support and participation in NASB.

Version 13.1.22.12

NRCSA Update



# Nebraska Rural Community Schools Association

*Member Update*

*February 8, 2024*



*Photo Credit: Kimball Public Schools*



[www.nrcsa.net](http://www.nrcsa.net)



[www.twitter.com/NRCSA1980](https://www.twitter.com/NRCSA1980)



[www.facebook.com/nrcsahome/](https://www.facebook.com/nrcsahome/)



# *NRCSA Calendar*

---

## **NRCSA Events**

### **NRCSA Legislative Forum**

February 20, 2024  
Cornhusker Hotel in Lincoln

[More about this event](#)

### **NRCSA Spring Conference**

March 14 & 15, 2024  
Crowne Plaza & Younes North Convention Center in  
Kearney

[More about this event](#)

### **NRCSA Golf Tournament**

July 23, 2024  
Meadowlark Hills Golf Course in Kearney

[More about this event](#)

## **Committee Meetings**

### **NRCSA Scholarship & Recognition Committee Meeting**

February 7 & 8, 2024  
KSB Confernece Room in Lincoln

### **NRCSA Legislative Committee**

January to April 2024  
Every Thursday during the Legislative Session  
Via Zoom

### **NRCSA Executive Committee**

March 12, 2024  
7:00 PM, Room 174  
Holiday Inn in Kearney



## *NRCSA Search Service*

---

**Please let Jack Moles know where superintendent vacancies occur, so that NRCSA Superintendent Search can make direct contact. We need to hear as soon as possible in anticipation of getting promotional materials specific to that board of education ready. It is critical that Board Presidents have the NRCSA contact information so that if they choose to consider a Superintendent Search Service, NRCSA is one they hopefully will consider.**



### **Raymond Central Public Schools**

Application Process Complete  
Finalists Selected: **December 13, 2023**  
Interviews: **December 16, 2023**  
Contract Start Date: **July 1, 2024**



### **Sioux County Public Schools**

Application Process Complete  
Finalists Selected: **February 12, 2024**  
Interviews: **February 19, 2024**  
Contract Start Date: **July 1, 2024**

Access the Members area of [www.nrcsa.net](http://www.nrcsa.net) anytime.

**Login: member Password: playground**

**Preparations for the 2024 NRCSA Legislative Forum on Tuesday, February 20, at the Lincoln Cornhusker Marriott are complete.**

Invitations to speak and attend the Luncheon with Senators have been made. Superintendents and Board of Education members, please plan to attend. It is more important than ever to attend and encourage your senator to attend and meet with you. Registration forms for this event are available now. The tentative list of speakers includes:

8:30 a.m.--Sen. Linehan  
9:00 a.m.--Sen. Murman  
9:30 a.m.--Sen. Hughes  
10:00 a.m.--Open Sky  
10:30 a.m.--Sen. Dorn  
11:00 a.m.--Sen. Brandt  
11:30 a.m.--Sen. Dungan

The Cornhusker is a Marriott Hotel; they have instructed customers to use the central reservation line or the link below to reserve a room.

\*Cornhusker Marriott Hotel: 1-866-706-7706\*

You may be able to secure a government rate because you represent a school district.

### **Registration Forms**

[2024 NRCSA Legislative Forum Registration Form](#) (online version)

[2024 NRCSA Legislative Forum Registration Form](#) (MS Word version)

### **Check your registration**

If your name appears on the list below you ARE registered to attend the Forum. If your name does not appear you ARE NOT currently registered to attend the Forum

[2024 NRCSA Legislative Forum Attendees](#)

---

**The NRCSA Spring Conference is approaching!** Mark your calendars for March 14 & 15, 2024 at the Crowne Plaza and Younes North Convention Center in Kearney. There will be many informative and timely sessions regarding law, TEEOSA, school finance, curriculum development, updates from the Department of Ed, staff and board development, updates regarding current federal and state legislation and others. Sessions highlighting special programs and initiatives are always a plus. A total of 35 sessions will be provided at the conference. As always, the general sessions will feature music groups, speakers on Thursday and Friday, scholarships, awards, recognitions, and the traditional

### **NRCSA Leadership**

Mark Lenihan, President.  
Wayne Community Schools

Dr. Dawn Lewis, Past President.  
Arlington Public Schools

Dr. Heather Nebesniak, Pres-Elect.  
Ord Public Schools

Chris Proski, Secretary.  
Southern School District # 1

### **District Representatives:**

Eugene Hanks, West  
Crawford Public Schools

Dale Hafer, North Central  
Ainsworth Community Schools

Dr. Jon Cerny, Northeast  
Bancroft-Rosalie Community Schs

Paul Sheffield, Southeast  
Exeter-Milligan Public Schools

Jon Davis, South Central  
Alma Public Schools

Jane Davis, Southwest  
Hershey Public Schools

### **Executive Director:**

Jack Moles

### **Lobbyists:**

Jon Edwards  
Scott Moore  
Russell Westerhold

### **Legislative Co- Chairs:**

Dr. Jason Dolliver  
Pender Public Schools

Bryce Jorgenson  
Southern Valley Schools

### **Scholarship & Recognition Co Chairs:**

Tim Heckenlively,  
Falls City Public Schools

Jim Widdifield  
Minden Public Schools

meals that have become a mainstay of the conference. Be sure to make plans for you and your board members to attend.

NCRSA is pleased to partner with [FranklinCovey](#), the most trusted leadership company worldwide, to provide NCRSA members with the opportunity for a free preconference as a companion to the Spring Conference. The first 150 people to register will have the opportunity to receive a full day of leadership focused professional development on March 13 with the opportunity for another free remote day at a later time. **Register now to secure your spot. Again, this is 100% free to NCRSA members but limited to 150 attendees.**

Some thoughts on who might consider signing up for this free preconference:

- Newer in their administrative careers Superintendents or Principals who would like to look at ways in which they can grow their individual leadership skills
- Whole administrative teams that want to consider how they might redefine their team leadership
- Board of Education Presidents who want to grow their leadership capabilities
- Veteran Superintendents or Principals who want to pick up some ideas for growing their leadership skills
- Teachers who are preparing to enter the Administrative field in the coming years

#### About the session

In the context of leadership in rural schools, the dynamic landscape of the world is undergoing unprecedented changes.

Leaders in rural educational settings find themselves navigating uncharted territories, making numerous decisions daily, and confronting challenges that were previously unknown. The strategies that proved effective yesterday may undergo overnight transformations. The pace of change is relentless, and the stakes are elevated. However, the potential rewards are significant for those who can guide a team to consistently achieve outstanding results.

Given the rapid and constant changes, how can leaders in rural schools stay ahead of the curve and set themselves and their teams apart?

#### [Introducing The 4 Essential Roles of Leadership.](#)

Even amidst the turbulence of the times, there exist four leadership roles that strongly indicate success. Termed essential, these leadership roles play a pivotal role in guiding leaders in rural schools. As leaders conscientiously guide themselves and their teams in harmony with these roles, they establish the groundwork for effective leadership. This is ideal leadership development for superintendents, principals, teacher leaders, and board presidents.

Thank you to Sam Stetcher for Making this Possible. After 26 serving in Nebraska Public Education, Sam has changed lanes. He now works for FranklinCovey, who you most likely know because of the 7 Habits of Highly Effective People. FranklinCovey has a funding partner passionate about helping school leaders increase their capacity to excel. They are kicking in money so that school leaders can have access to professional development called The 4 Essential Roles of Leadership. This isn't fluff. It's world class leadership development that normally comes at a pretty high price point. But through a collaboration between NCRSA and FranklinCovey, we can offer this to members at no cost.

#### [Sam has recorded a short promotional video about the Pre-Conference.](#)

#### Registration Forms

[2024 NCRSA Spring Conference Registration Form](#) (online version)

[2024 NCRSA Spring Conference Registration Form](#) (MS Word version)



**The Unicameral is now over a third of the way through its 60-day session.** Hearings on bills are nearing the end, at which point the Unicameral will go to full day floor debate. The NRCSA Legislative Committee plans on meeting most Thursdays during the session to discuss NRCSA's views on bills. NRCSA will attempt to keep you as up-to-date as possible as to what is going on in the Unicameral. If you have questions please don't hesitate to contact Jack.

Here is the NRCSA's list of bills of interest to education.

### **[NRCSA Bills of Interest](#)**

---

**NRCSA's Scholarship and Recognition Committee met this week to select award honorees and scholarship recipients.** Both awards and scholarships will be announced at the Spring Conference in March. Those who made nominations for awards will be notified as to the status of their nominations ahead of the Spring Conference, likely by early in the coming week.

---

**NRCSA has had the great privilege to work closely with Open Sky Policy Institute over the years.** They provide great information on the fiscal impact of legislation that is very helpful to me in my work as NRCSA's chief lobbyist. I would encourage Superintendents and Board of Education members to sign up to receive Open Sky's email updates.

The mission of OpenSky Policy Institute is to provide impartial and precise research, analysis, education and leadership on fiscal policy-improving opportunities for all Nebraskans. Subscribe to their email updates at:

**<https://bit.ly/OpenSkyUpdates>** or contact Todd Henrichs at **[thenrichs@openskypolicy.org](mailto:thenrichs@openskypolicy.org)**.

---

**NRCSA will be seeking volunteers for both elected and appointed positions for 2023-24.** Interested persons may self nominate or be nominated by another person. If you would like to nominate yourself or nominate someone else please contact Jack Moles. Open positions will be:

#### **Executive Committee:**

**President-Elect** - This is a Statewide position voted on by all NRCSA members. The elected candidate will serve a three-year term as President-Elect, then President, and then Past President. Candidates must be from a NRCSA member school district and membership in NRCSA must be maintained throughout the length of service.

**West Dist Representative** - Eugene Hanks is finishing his first term and is eligible to run for a second term of office. He has indicated that he intends to run for a second term. District Representatives serve three-year terms and may serve two consecutive terms. District Representatives are voted on only by members in the NRCSA District. Candidates must be from a NRCSA member school district and membership in NRCSA must be maintained throughout the length of service.

Northeast Dist Representative - Dr. Jon Cerny is finishing his appointment to fill Dr. Dawn Lewis's term and is NOT going to run for his own term of office. District Representatives serve three-year terms and may serve two consecutive terms. District Representatives are voted on only by members in the NRCSA District. Candidates must be from a NRCSA member school district and membership in NRCSA must be maintained throughout the length of service.

South Central Dist Representative - Jon Davis is finishing his first term and is eligible to run for a second term of office. He has indicated that he intends to run for a second term. District Representatives serve three-year terms and may serve two consecutive terms. District Representatives are voted on only by members in the NRCSA District. Candidates must be from a NRCSA member school district and membership in NRCSA must be maintained throughout the length of service.

Southwest Dist Representative - Jane Davis is finishing Alan Garey's first term and is eligible to run for her own term of office. She has indicated that she plans to run for her own term of office. District Representatives serve three-year terms and may serve two consecutive terms. District Representatives are voted on only by members in the NRCSA District. Candidates must be from a NRCSA member school district and membership in NRCSA must be maintained throughout the length of service.

### **Legislative Committee:**

Co-Chair Dr. Jason Dolliver is finishing his second term and can be appointed to a third term.

Vern Fisher, Superintendent at Gibbon (South Central Dist) is completing his first term on the Legislative Committee and can be appointed to a second term. Legislative Committee members are appointed by the Executive Committee and serve three-year terms with a limit of two consecutive terms.

Dr. Nick Mumm, Superintendent at Giltner (Southeast Dist) is completing his first term on the Legislative Committee and can be appointed to a second term. Legislative Committee members are appointed by the Executive Committee and serve three-year terms with a limit of two consecutive terms.

Patrick Ningen, Superintendent at North Bend Central (Southeast Dist) is completing his first term on the Legislative Committee and can be appointed to a second term. Legislative Committee members are appointed by the Executive Committee and serve three-year terms with a limit of two consecutive terms.

Hqrlan Ptomey, Superintendent at Cedar Bluffs (Southeast Dist) is completing his second term on the Legislative Committee.. Legislative Committee members are appointed by the Executive Committee and serve three-year terms with a limit of two consecutive terms.

### **Scholarship & Recognition Committee:**

Mike Eldridge, Superintendent at East Butler (Southeast Dist); Kyle Finke, Superintendent at Summerland (Northeast Dist); Dade McDonald, Superintendent at McCool Junction (Southeast Dist), and Dr. Kathy Urbanek, Superintendent at Mitchell (West Dist) are all completing two years of service on the Committee. Scholarship and Recognition Committee members are appointed by the Executive Committee and serve a term of two years.

### **Closing the Achievement Gap Research Team:**

There are no known openings on this committee in 2023-24. Closing the Achievement Gap Research Team members are appointed by the Executive Committee.

### **Rural Teacher Committee:**

Open positions on the committee will be appointed by the Executive Committee. At present, we do expect two openings on the committee for 2024-25.

**At the Membership Meeting during the Spring Conference on Friday, March 15**, the Executive Committee will be presenting updated NRCSA Constitution/By-Laws for approval by the membership. According to NRCSA rules, such issues must be shared with the membership prior to the meeting. Below are links to a working copy with suggested revisions and a proposed copies that will be voted on for adoption.

[Working copy](#)

[Proposed copy](#)

---

**The National Rural Education Association, in partnership with the Rural Schools Collaborative, has issued a study entitled WHY RURAL MATTERS.** The report “looks critically at how educational supports and resources for student well-being are being distributed, casting light on which of our rural children are in need of additional support”. The study is well done and shows Nebraska in a pretty positive light. I would encourage you to take a look at WHY RURAL MATTERS, which can be accessed here:

[Why Rural Matters](#)

---

**The National Rural Education Advocacy Coalition (NREAC) partnered with AASA in producing a report on REAP. REAP is a program that benefits many of our smaller districts.** The report can be accessed here:

<https://www.aasa.org/docs/default-source/resources/reports/rural-education-achievement-program-survey-report.pdf>

[Understanding REAP](#)

---

**Team NRCSA represented NRCSA on a high level in the Market to Market Relay.** On Saturday, October 7 an outstanding group of runners, plus another guy, placed 4th in the Mixed Masters Division in the Omaha to Lincoln relay. Team members included Mike Eldridge (East Butler Supt.), Megan Kozisek (East Butler Board of Ed President), John Skretta (ESU 6 Administrator), Dawn Lewis (Arlington Supt. and NRCSA Past-President), Kraig Lofquist (ESUCC Executive Director), James McGown (ESU 16 Administrator), Megan McGown, and NRCSA Executive Director Jack Moles. A great time was had by all, with a lot of great team building.



**NRCSA is pleased to announce a partnership with New Leaf Teletherapy.** New Leaf provides mental health teletherapy services for both staff and students. I became very interested in this possibility especially in terms of staff services. I know our members are working hard to provide services for their students, but there does not appear to be that same capability when looking at staff services.

I look at this service as helping to bolster what your district is already doing, not to take the place of those efforts. I believe this can be a cost effective means of furthering your efforts.

NRCSA recently hosted three introductory Zoom meetings with Mark Goldman and Deb Romano of New Leaf to have them explain what the program would look like. Below you can access the slide show from those meetings, as well as a recording of one of the meetings.

[New Leaf PowerPoint Presentation](#)

[New Leaf Zoom Meeting](#) (recording)



If you would like to be in contact with Mark Goldman or Deb Romano, please feel free to call or email me and I can help make that happen.

---

**Board of Education meeting visits.** Beginning in December, 2019, I started attending Board of Education meetings in member school districts/ESUs. Since then, I have attended 93 such meetings. I recently attended the Board meetings at Pierce and Stanton on Dec. 11. Upcoming visits to Board meetings include:

- **Monday, Feb. 12** at Hitchcock County and Hayes Center
- **Tuesday, Feb. 13** at ESU 15 (tentative) and Chase County
- **Monday, March 11** at Battle Creek and Randolph
- **Monday, April 8** at Tekamah-Herman and Oakland-Craig

I have really enjoyed this and am willing to attend Board meetings when I can. I take a few minutes to cover NRCSA news and offerings, as well as some legislative news. When I am going to be in a specific area on Board meeting days I may send out a notice to near-by Superintendents to make an offer to visit. I'd like to be able to schedule two or three in the same evening if I can.

If you would be interested in me attending a future Board meeting, please contact me to start the arrangements. I would also be willing to "attend" your Board meetings via Zoom if you preferred. I would still only do one at a time but would be able to do several in the same evening. Let me know and we will try to make the connection.



*NRCSA EXECUTIVE DIRECTOR JACK MOLES WITH THE STANTON COUNTY BOARD OF EDUCATION & ADMINISTRATION*

**The American Heart Association is committed to partnering with schools in rural Nebraska to improve the health of their communities. A few of these opportunities include:**

**Tobacco Free Schools.** Unfortunately, recent data reveals the ongoing challenges of youth tobacco use. The 2021 National Youth Tobacco Survey showed that: Approximately 2 million MS/HS students reported using e-cigarettes during the pandemic; nearly 85% of them used flavored tobacco products. More than 4 in 10 HS students and nearly 2 in 10 MS students who used e-cigarettes did so 2 out of 3 days and youth showed a strong brand preference.

Many schools have struggled to keep up with the continued innovation of the tobacco industry. To help address that, the American Heart Association created our Tobacco Free Schools Toolkit. The toolkit is designed to help schools update their policies so that now – and in the future – they will cover all products, people, and places while providing mechanisms that support students who are battling tobacco addiction. More information/resources are here.

**Improving Cardiac Response in Schools.** In the aftermath of a cardiac emergency -minutes matter. The Chain of Survival starts with those who are present and requires everyone to do their part. This is especially true in rural communities where EMS resources are often further away. We recently launched a series of new tools to help schools, youth sports, and other entities develop Cardiac Emergency Response Plans. These plans consider: access to functioning AED's, a strong base of CPR knowledge and training, as well as the identification of a response team and the annual practice of a cardiac emergency.

For questions about these or other initiatives, please reach out to Tim Nikolai, Sr. Rural Health Director, at Tim.Nikolai@heart.org.

A note from Mr. Nikolai:

*For those I have not met previously, I am the **American Heart Association's** lead for rural health in the Midwest Region, inclusive of your states. My role allows me to work collaboratively with all manner of organizations that are in a position to impact health in their communities – and schools are certainly near the top of that list.*

*There are many ways our organization has worked to collaborate with schools – supporting access to nutritious, affordable food, helping to address the ongoing challenges of vaping/tobacco use, and more. Today, though I'm focusing primarily on our resources to assist with cardiac readiness / cardiac emergency response planning.*

*Much of the country was watching – or has followed since – the **collapse of Buffalo Bills' safety, Damar Hamlin, on Monday Night Football.** Fortunately, Damar's story had a happy ending. Our goal is to maximize the opportunity for everyone to have a similar outcome should they experience a Sudden Cardiac Arrest. Most organizations will not have the resources that the NFL does to ensure player safety, but there is much that can be done, especially with proper planning.*

*Some data suggests that **nearly 1% of schools will be the site for an out of hospital cardiac arrest annually.** For a variety of reasons, rural areas are disproportionately impacted by both rates of cardiac arrest and poor outcomes. We know that prepared and equipped schools mean better outcomes for staff, students, visitors, and the communities that so often gather in school spaces.*

*We have recently built out/updated a variety of tools to assist schools – and other organizations – with their cardiac readiness. These include:*

- *Sample Cardiac Emergency Response Guidelines and Plans.*
- *A toolkit to maximize the impact of AED placement and implementation.*
- *Training and awareness tools to help with Hands-Only CPR knowledge for staff and students.*

- *A revamped, training site search feature, for coaches, nurses, and others who need CPR certification.*
- *In some cases, we may have – or be able to help secure – financial resources to help schools with purchasing/maintaining AEDs, CPR mannequins, etc. Hearing the scope of that need can help us secure additional resources, so please let us know!*

***Please let me know if you see an opportunity or need to dialogue about these resources further or share them with your member districts. I'm happy to assist with newsletter copy, join or host webinars, or other ideas that fit your standard means of communication.***

*Finally, at the risk of sharing too much – a few other notes I wanted to highlight.*

- *I've attached an invitation for our **Fall Educator Series**. Administrators/Educators from all districts are welcome to attend the sessions they are interested in. You'll see the one in November is on Cardiac Emergency Response Planning.*
- *Last year some 1300+ rural schools in the Midwest participated in our Kids Heart Challenge program. They raised life-saving money for our mission, earned PE equipment for their schools, and helped improve health knowledge in their community. Last year, tens of thousands of families learned Hands-Only CPR through the program.*
- *Thanks to the **Missouri Rural Health Association** for sharing our HeartCorps program on their home page. That opportunity exists for IA, KS, KY, MN, MO, NE, OH, and WI. Happy to chat more!*

### [American Heart Association Service Summary](#)

---

### **Farm to School Network Takes Root in Nebraska**

The Nebraska Department of Education, Center for Rural Affairs, Nebraska Extension, Buy Fresh Buy Local, and No More Empty Pots are pleased to announce the establishment of the Farm to School Network in Nebraska. The network aims to increase access to fresh and nutritious foods in Nebraska schools and strengthen connections between local farmers, educators, and communities.

To build this network, a Network Development Committee and Advisory Committee will lead the process and guide stakeholders to create a strategic, collective action plan that will move farm to school forward in Nebraska. The Network Committees are made up of representatives from key organizations and institutions across the state and are focused on breaking down barriers standing in the way of implementing farm to school initiatives.

The Network Committees will begin the network building process with mapping community assets, phase one of the Nebraska Farm to School Network Timeline. Through this phase, they will collect information on existing farm to school activities in the state and establish a vision for the network.

All stakeholders interested in building a stronger and healthier food system in Nebraska may participate in upcoming virtual and in-person listening sessions. These listening sessions will take place from October 10th to 18th and provide a platform for sharing information about current farm to school activities and discussing the future vision for the network.

“Pillars to farm to school success in a state include partnerships, policies, and supportive programming. A network will support development of these initiatives,” said Sarah Smith, Nebraska Department of Education Farm to School Specialist and Project Director.

To register for the listening sessions or to learn more about the Nebraska Farm to School Network, please visit the [Network's webpage](#).

---

**Southern Superintendent Chris Prosocki has shared a sample Superintendent Checklist that he uses.** I thought this was a great instrument, one that I wished I had available to me when I was in the Superintendency. It can be especially helpful as you head into the new school year! Thanks to Chris for sharing this! You can access the updated checklist here:

### **[Superintendent Check List](#)**

---

**The ESUCC and ESU 3 have shared a document which outlines all of the trainings and mandates that are required of districts.** The document, “School District Plans, Policies, and Annual Trainings Requirements”, is a handy reminder for districts. Thanks to ESUCC Executive Director Kraig Lofquist and ESU 3 Administrator Dan Schnoes for developing and distributing this handy tool. The document may be accessed here:

### **[School District Plans, Policies, & Annual Trainings](#)**

---

**We urge you to consider participation in the NRCSA Partner OneCard program** as a tool for you in managing school expenditures, both large and small. Certainly, the card can help reduce/eliminate any issues relative to unverified cash expenditures. You decide who uses it, can get cards for each of those users, keep all cards wherever you wish, determine the amount to load on each individual card, and how long the time frame of use is. It is a terrific management tool and clearly identifies each expenditure/name/date/amount. Whether small purchases or very large purchases, the card is a terrific tool. NRCSA owns the state contract, so liability for misuse falls to NRCSA, not the district user. We have only had three circumstances of fraud and all three have been the theft of the card number information, not any district employee misuse. For 2022-23, 97 districts/ESUs participated in the program. We have received interest from several districts already this year, so we believe we will end up with over 100 entities using the program. Great job by all participating districts in protecting the card and program! Don't forget, the NRCSA rebate from the transaction fee paid by businesses that choose to accept plastic is used for scholarship, awards, and special needs. For 2022-23, the rebate was almost \$29,000 to NRCSA, showing that use is increasing, and large purchases are being included. WIN, WIN, WIN! If you are considering joining the program and need more information, please contact Jack Moles ([jmoles@nrca.net](mailto:jmoles@nrca.net)) or Jeff Bundy ([jbundy@nrca.net](mailto:jbundy@nrca.net)).

# 2024 NRCSA Legislative Forum

The 2024 NRCSA Legislative Forum will be held on Tuesday, February 20, 2024, at the Cornhusker Marriott Hotel in Lincoln.

This year's program will feature remarks by many educational policy leaders.

There will again be the opportunity to discuss issues of local interest with senators over lunch. This provides an invaluable opportunity to network and discuss issues with your senator.

**Be sure and make plans to attend!!**

## Room Reservations

There are rooms available at the Cornhusker Hotel at a discounted rate of \$116.00 per night for Monday February 19, 2024. The Cornhusker is a Marriott Hotel; they have instructed customers to use the central reservation line to reserve a room.

\*Cornhusker Marriott Hotel: 1-866-706-7706

*\*The deadline to reserve from NRCSA's room block has passed. However, you may still be able to secure a government rate as a representative of a school district.\**

## Program Highlights

Tuesday February 20, 2024

**8:20 A.M.** - Welcome & Announcements by Legislative Committee Co-chairs Dr. Jason Dolliver & Bryce Jorgenson, Pender Public Schools & Southern Valley Public Schools

**8:30 A.M.** - Senator Lou Ann Linehan, Dist 39; Revenue Committee Chair

**9:00 A.M.** - Senator Dave Murman, Dist 38; Education Committee Chair

**9:30 A.M.** - Senator Jana Hughes, Dist 24; General Affairs Committee Vice Chair

**10:00 A.M.** - Rebecca Firestone; Open Sky Policy Institute

**10:30 A.M.** - Senator Myron Dorn, Dist 30

**11:00 A.M.** - Senator Tom Brandt, Dist 32

**11:30 A.M.** - Senator George Dungan, Dist 26

**12:00 P.M.** - Lunch with Senators

**1:10 P.M.** - Jack Moles & Russ Westerhold; NRCSA Executive Director & Lobbyist

**1:45 P.M.** - Closing & Adjourn

*Please note: The schedule is subject to change.*



# NEBRASKA RURAL COMMUNITY SCHOOLS ASSOCIATION

455 S. 11th St, Suite B  
Lincoln, NE 68508

## 2024 NRCSA Legislative Forum Registration Form

Please complete the following form for those individuals attending the NRCSA Legislative Forum on Tuesday, February 20, 2024, at the Cornhusker Hotel in Lincoln.

Attending the seminar will be the following:

School  
District: \_\_\_\_\_

*Please list the individual's full name and the first name or nickname, as you would like it to appear on the nametag.*

Full Name:	Name for name tag:

**CONFERENCE FEES:** (Please check appropriate space)

- Member Registration--\$100.00 for first person, \$50.00 for each additional person \$ \_\_\_\_\_
- Non-Member Registration--\$130.00 per person \$ \_\_\_\_\_
- Total Enclosed \$ \_\_\_\_\_

Send Registrations and payments to:

NRCSA  
455 S. 11th St, Suite B  
Lincoln, NE 68508

Fax: 402-476-7740  
email:jbundy@nrca.net

**SCHOOLS WILL BE RESPONSIBLE FOR REGISTRATIONS CANCELED AFTER  
February 16, 2024**

# 2024 NRCSA Spring Conference

The 2024 NRCSA Spring Conference will be held on March 14 & 15, 2024, at the Crowne Plaza and Younes North Convention Center in Kearney.

There will be many informative and timely sessions regarding law, TEEOSA, school finance, curriculum development, updates from the Department of Ed, staff and board development, updates regarding current federal and state legislation and others. Sessions highlighting special programs and initiatives are always a plus. A total of 35 sessions will be provided at the conference. As always, the general sessions will feature music groups, speakers on Thursday and Friday, scholarships, awards, recognitions, and the traditional meals that have become a mainstay of the conference.

As usual, there will be many opportunities for networking and informal discussions with attendees from other schools!

**Be sure and make plans to attend!!**

## Room Reservations

There are several hotels in and around the area. Attendees will need to make room arrangements for the conference.

These hotels participate in group rates for Spring Conference

Crowne Plaza (308) 238-7000  
Hampton Inn (308) 234-3400

These hotels do NOT participate in group rates

Holiday Inn (308) 237-5971  
Comfort Inn & Suites (308) 236-3400  
La Quinta Inn & Suites (308) 237-4400  
America Inn & Suites (308) 234-7800  
Fairfield Inn (308) 236-4200  
Holiday Inn Express (308) 234-8100  
Microtel Inn & Suites (308) 698-3003  
New Victorian Inn & Suites (308) 237-5858  
Wingate Inn (308) 237-4400

## Program Highlights

### Wednesday March 13, 2024

**10:00 AM Pre-Conference:** 4 Essensial Roles of Leadership

**Presented by:**



**6:30 PM** Exhibitor Check-In and Set-Up

**7:00 PM** Early Registration and Hospitality Rooms Open

### Thursday March 14, 2024

**7:15 AM** Registration & Exhibit Hall Open

**8:00 AM** General Session

**11:00 AM – 11:50 AM** Select-a-Session I

**12:00 PM** General Session

**2:20 PM - 3:10 PM** Select-a-Session II

**3:35 PM - 4:25 PM** Select-a-Session III

**6:00 PM** Country Buffet

**7:00 PM** Hospitality Rooms Open

### Friday March 15, 2024

**7:30 AM** Registration Open

**8:00 AM- 8:50 AM** Select-a-Session IV

**9:00 AM – 9:50 AM** Select-a-Session V

**10:00 AM** Brunch

**10:50 AM** Closing Session

**12:50 PM** Gifts, Prizes, & Giveaways



**NRCSA Spring Conference  
March 13 - 15, 2024  
Crowne Plaza & Younes North Convention Center**

**Registration Form**

School or Institution Name: \_\_\_\_\_

District Phone No: \_\_\_\_\_ Contact Person: \_\_\_\_\_

Address: \_\_\_\_\_ City: \_\_\_\_\_ Zip: \_\_\_\_\_

Contact Person e-mail Address: \_\_\_\_\_

**Pre-Conference Leadership Seminar – 10:00 AM Wednesday, March 13, 2024**

**4 Essential Roles of Leadership** brought to you by:



Registrant's Full Name	Name for Nametag	Wednesday Lunch 3-13-24
John Smith	John	X

*This pre-conference leadership seminar by FranklinCovey is free for NRCSA members but space is limited to the first 150 registrants.*

**2024 NRCSA Spring Conference – March 14 & 15, 2023**

Please register **ONLY** for the meals the registrant will attend  
**\*\*Note: Meal Fees are included in Conference Fees\*\***

Registrant's Full Name	Name for Nametag	Conference Fees: \$220.00 – Member \$360.00 – Non-Member	Thursday Lunch 3-14-24	Thursday Dinner 3-14-24	Friday Brunch 3-15-24	Total
John Smith	John	\$220.00	X	X	X	\$220.00

Spouses/Guests	Additional Meals for Spouses or Guests		\$30.00	\$25.00	\$23.00	Total
	No Conf Fee Needed	No Conf Fee Needed				
	No Conf Fee Needed	No Conf Fee Needed				
	No Conf Fee Needed	No Conf Fee Needed				

Make Checks Payable to: **NRCSA**

**Total Enclosed:**

Mail or Fax Registrations To:

**NRCSA Spring Conference**  
**455 S. 11th St, Ste B**  
**Lincoln, NE 68508**

**Fax: (402) 476-7740**

**Or register on-line at: [www.nrcsa.net](http://www.nrcsa.net)**

**NO REFUNDS AFTER March 11**



**NRCSA wishes to share in the celebration of the special accomplishments and recognitions going on in our member schools and ESUs.**

**February 2024:**

\* Several NRCSA-member districts are recipients of Arts NOW Grants through the Nebraska Department of Education. Through the grants, students will be able to have experiences in the arts made available. Districts who received Arts NOW Grants and the name of the arts project include:

- Arthur County: “Enhancing Fine Arts Education: Stage Curtain Renovation”
- Axtell: “Welcome to the World”
- Battle Creek: “Pottery Experience Project”
- Bayard: “Integrating New Stage Curtains”
- Boyd County: “Ceramics Project”
- Cedar Bluffs: “Lighting and Sound Systems”
- Creighton: “Sound System Project”
- DC West: “West African Drumming Project”
- Dundy County-Stratton: “Mosaic Mural Project”
- Emerson-Hubbard: “Music Project”
- Falls City: “Fine Arts Department Digital Project”
- Leyton: “Quality Sound System Project”
- Maywood: “World Music Drumming Project”
- Northwest: “Stage Lighting”
- Paxton: “Instruments, Old to New”
- Scribner-Snyder: “Community Clay Experience”
- Tekamah-Herman: “Ukeleles”

\* Isabella Meyer of Boone Central is one of two students in Nebraska to be selected as delegates to the 62nd annual United States Senate Youth Program (USSYP) held in Washington, D.C. March 2-9, 2024. She will be one of only 104 students from across the United States to take part in the program. Jacob Dominguez of West Point-Beemer was selected as one of two alternates from Nebraska.

\* Wisner-Pilger Elementary School was one of two Nebraska schools to be recognized by the National Association of ESEA State Program Administrators (NAESPA) as 2023 National ESEA Distinguished Schools. Wisner-Pilger Elementary was recognized for exceptional student performance and academic growth.

\* Several individuals with ties to NRCSA-member schools were recently elected to the Eight-Man Football Hall of Fame. Included were players Steve Bazata (Howells, now part of Howells-Dodge), Josh Frerichs (Lodgepole), Brian Hahn (Hampton), Brandon Johnson (Rushville, now part of Gordon-Rushville), Jerry Leiss (Indianola, now part of Southwest), Matt McGinn (Anselmo-Merna), Travis Mlady (Bloomfield), Jeff Veerhusen (Adams, now part of Freeman). Coaches elected to the Hll include Jon Dahl (Mead) and Curt Johnson (Lawrence, now part of Lawrence-Nelson).

\* Conestoga's CyberPatriot team finished first in state in its division, as well as having the overall highest score in Nebraska competing against many schools, including some of the largest schools in the metro areas. The team also finished in the top 25% of its tier nationally which allows them to move on to the semi-finals. CyberPatriot's National Youth Cyber Defense Competition is the world's largest cybersecurity competition and is open to all schools and approved youth organizations.



CONESTOGA CYBERPATRIOT TEAM

\* The National Football Foundation names its state winners of 2023-24 NFF National High School Academic Excellence Awards. Among the teams honored were NRCSA members Gothenburg (Class C1), Exeter-Milligan/Friend (D1), Verdigre (D2), and Hampton (D6).

\* Several players from NRCSA-member schools were selected for the 2024 Nebraska Shrine Bowl rosters. Named to the South team were: Ryker Evans (Hi-Line), Breckan Schluter (Exeter-Milligan/Friend), Caden Rezac (Ogallala), Kellen Peterson (Aurora), Treshaun Beed (Aurora), Dylan Eby (Plattsmouth), Orion Parker (Plattsmouth), Jackson Turner (Fillmore Central), Jake Ryan (Minden), Dalton Amen (Malcolm), Ryker Wohlers (DC West), Patrick Gross (McCook), Tanner Bolte (BDS), Jackson Kerchal (Dundy County-Stratton), and Maverick Binder (Auburn). Named to the North team were: Trey Appelt (Ainsworth), Hank Hudson (Boone Central), Trent Patzel (Boone Central), Brice Chaplin (Broken Bow), Humberto Adame (Lakeview), Joseph Stein (Northwest), Chase Wiegert (Northwest), Blake Borchers (Battle Creek), Cael Peters (Mitchell), Bryson Gadenken (Neligh-Oakdale), Tucker Shabram (O'Neill), Trent McCain (Ord), Keenan Valverde (Pierce), Isak Doty (Sidney), Mitchell Hupp (Stanton), and Braydon Wobken (LVSS). Clint Ardissono of BDS is on the South coaching staff. Ron Beacom of Neligh-Oakdale and Ryan Smith of Sidney are on the North coaching staff.

\* St. Paul won the Class C State Championship at the NSAA State Wrestling Duals. They defeated Minden in the final.

\* Jersi Jensen of Wayne was the Class B Girls State Bowling Individual Champion. The Wayne Girls won the Class B Girls State Bowling Team Championship.



Jersi Jensen



Wayne Girls Bowling Team

\* The NSAA's "Champions for Coaches" program was designed to honor active coaches who go above and beyond for kids and the community. Students, administrators, parents/guardians, and community members were encouraged to nominate coaches that have made a significant impact in their school and community. Coaches from NRCSA-member schools who were selected include: Amy Allgood of Boone Central (Girls Golf), Rob Sweetland of Wayne (Softball), Janie Kuncl of Mullen (Boys Cross Country), Jordynn Luettel of Elgin (Volleyball), Lana Cool of Arnold (Play Production), Bob Rainer of Bancroft-Rosalie (Girls Bowling), Garrett Schultz of Raymond Central (Girls Wrestling), Keaton Gracey of Minden (Boys Wrestling), Brandon Rohr of Amherst (Girls Basketball), Kate Diaz of Ogallala (Speech/Debate), Megan Unwin of Oakland-Craig (Girls Track & Field), and LaTravia Dobson of Riverside (Boys Track & Field).

\* Team NRCSA won a hotly contested battle with Team NCSA in the 4th Annual NRCSA-NCSA Bowl Game Challenge. Members of the 6-person teams had to pick the winners of all of the college football bowl games using the point spread. Team NRCSA won to even the series at two championships apiece. Chris Kuncl (Supt. at Mullen) of Team NRCSA was the individual champion among the twelve contestants. Members of Team NRCSA were Chris, Jeff Bundy, Jon Cerny (Supt. at Bancroft-Rosalie), Jon Davis (Supt. at Alma), Mark Lenihan (Supt. at Wayne and current NRCSA President), and Jack Moles.



**The National Rural Education Advocacy Consortium (of which NRCSA is a member) continues to represent rural education on the Federal level.** NREAC is an extension of the National Rural Education Association. Dr. Jon Habben, previous NRCSA Executive Director, serves as the NRCSA Federal Liaison.

A brief description of the six NREAC legislative priorities are as follows:

- 1) EDUCATION FUNDING: NREAC seeks preservation of critical federal funding for rural schools.
- 2) REAP FUNDING: NREAC urges Congress to increase funding to Title V, Part B of ESSA, the Rural Education Achievement Program, with a specific increase to the Rural Low-Income School Program.
- 3) INFRASTRUCTURE: NREAC supports efforts to ensure any infrastructure proposal in Congress must include funding for modernizing or maintaining rural school facilities.
- 4) FOOD AND NUTRITION: NREAC supports any effort to streamline processes and reduce the administrative burdens related to school meal programs.
- 5) SCHOOL SAFETY: NREAC supports flexible federal formula funding streams that channel resources to rural school districts for school safety that recognizes the geographic and economic challenges in rural communities.
- 6) BROADBAND AND CONNECTIVITY: NREAC believes access to high-speed internet is critical for providing equitable access to learning for students in rural schools. As such, NREAC strongly supports maintaining E-Rate as an element of the Universal Service Fund in its current funding structure.

### **NREAC Legislative Agenda**

---

**Last school year, NRCSA began a Principal Search Service.** This service is patterned after our successful Superintendent Search Service. Two options are available. Both options will involve NRCSA consultants recruiting candidates for the position. One option will involve the NRCSA consultant making background calls, while the reduced version of the service will place that role with the Superintendent. If you are interested in getting more information about the service now, please contact Jack. Here is a brochure outlining the service.

### **NRCSA Principal Search Brochure**

---

**An outstanding opportunity is available for rural districts or ESUs to “grow their own” School Psychologist.** I highly encourage someone in your school or ESU to apply for admission to the Prairie Nebraska Project through UNL.

With generous funding from the Behavioral Health and Education Center of Nebraska, the University of Nebraska Lincoln’s School Psychology program is recruiting 10 rural Nebraska residents to complete an Educational Specialist degree in School Psychology. The Prairie Nebraska project uses synchronous and asynchronous online instruction to deliver a program of study that is highly accessible for rural Nebraska residents. Students will be able to complete the training in their own community without having to relocate to Lincoln. Prairie Nebraska funds will pay for the trainees’ tuition and fees. Upon successful completion of the program, Prairie Nebraska trainees will qualify for an endorsement towards a Nebraska Department of Education certificate in School Psychology.

Successful applicants to the Prairie Nebraska program will:

- Live and work in any Nebraska county excluding Douglas, Lancaster, Sarpy, Washington, or Cass Counties.
- Have a recommendation from an ESU or school administrator with a commitment by the school/ESU to provide the experiences and supervision that trainees will need to complete the program.
- Apply to and be accepted into the University of Nebraska Lincoln Educational Specialist program in School Psychology.

Due to restrictions associated with the ARPA funds, all project-funded activities must be completed by December 2025. Consequently, we will be recruiting very quickly – with review of applicants beginning on

April 1, 2023 and continuing until the program is filled. Coursework and supervised practica will be tightly scheduled and offered one course at a time. Formal, synchronous courses and meetings will be scheduled outside of typical work hours (e.g., 5 PM or later) and will emphasize projects, assignments, and activities that have practical utility to prepare students for day-to-day practice as School Psychologists.

Interested applicants should email Beth Doll, [bdoll2@unl.edu](mailto:bdoll2@unl.edu) and include their:

- Name, email, and phone number
- Mailing address, including county of residence
- The school district or Educational Service Unit that is likely to provide their recommendation and commitment for supervised experiences

**NRCSA developed a corporate sponsorship/partnership program.** The program is designed to provide our corporate partners with more opportunities for contact with the decision makers in our member school districts, ESUs, and the colleges through increased exposure. Corporate partners are able to choose among three levels of sponsorship: Purple Ribbon Partners, Blue Ribbon Friends, and Red Ribbon Sponsors. Different forms of contact with our members are made available in each of the three levels.

---

### **New Collaboration Seeks to Address Principal Shortage and Strengthen Professional Development**

A new collaboration designed to address the shortage of future principals and strengthen professional development of current school leaders is underway. The project, entitled, Growth-Oriented Leadership Development (GOLD) is being coordinated by members of the UNL Department of Educational Administration, in partnership with NRCSA, NCSA, ESUs, and NDE.

“We’re seeking federal funds to develop current and future principals from within—a grow your own model, said Nick Pace, chair of the UNL Educational Administration Department. Over the next several months, Pace says a team led by professors Jiangang Xia and Scott Sturgeon will be inviting districts to join the effort. The team is inviting approximately 60 schools to participate, with half receiving focused training while the other half continues its current efforts without the training. Districts not initially selected for the training group would be first in line for the next round of the program, if funded.

Districts interested in participating should watch for information through NRCSA updates, ESU superintendent meetings, or by contacting Pace, Xia, or Sturgeon.

[Nick.Pace@unl.edu](mailto:Nick.Pace@unl.edu), [Jxia@unl.edu](mailto:Jxia@unl.edu), [ssturgeon2@unl.edu](mailto:ssturgeon2@unl.edu)

---



# Purple Ribbon Partners



## **Apptegy**

Emily Milnamow  
2201 Brookwood Dr, Suite 115  
Little Rock, AR 72202  
Phone: (317) 219-8686  
conferenceteam@apptegy.com



## **DA Davidson**

Paul Grieger  
450 Regency Parkway, Suite 400  
Omaha, NE 68114  
Phone: (402) 392-7986  
pgrieger@dadco.com



## **Cheever Construction**

Doug Klute  
3425 N 44th St  
Lincoln, NE 68504  
Phone: (402) 477-6745  
dklute@cheeverconstruction.com



## **DLR Group**

Emily O'keeffe  
6457 Frances St, Suite 200  
Omaha, NE 68106  
Phone: (402) 393-4100  
eokeeffe@dlrgroup.com



## **CMBA Architects**

Troy Keilig  
208 N Pine ST, Ste 301  
Grand Island, NE 68801  
Phone: (308) 384-4444  
keilig.t@cmbaarchitects.com



## **Facility Advocates**

Dave Raymond  
3738 S 149th St, Suite 102  
Omaha, NE 68144  
Phone: (402) 657-9177  
draymond@facilityadvocates.com



## **Cornhusker International Trucks**

Russ Folts  
3131 Cornhusker Hwy  
Lincoln, NE 68504  
Phone: (402) 304-4016  
russ.folts@cornhuskerinternational.com



## **MCL Construction**

Travis Justice  
14558 Portal Circle  
Omaha, NE 68138  
Phone: (402) 339-2221  
tkj@mclconstruction.com



# Purple Ribbon Partners



## **Network For Educator Effectiveness (NEE)**

Marc Doss  
288 Maguire Blvd  
Columbia, MO 65211  
Phone: (844) 793-4357  
dossm@missouri.edu



## **Tremco Roofing**

Tyler Petersen  
3735 Green Road  
Beachwood, OH 44122  
Phone: (909) 302-0617  
tpetersen@tremcoinc.com



## **Voss Lighting**

Randy Herrick  
4624 S 140th St  
Omaha, NE 68137  
Phone; (402) 850-9789  
randy.herrick@vosslighting.com

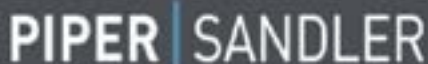

## **Piper Sandler & Co**

Jay Spearman  
11422 Miracle Hills Dr, Suite 408  
Omaha, NE 68154  
Phone: (402) 599-0307  
jay.spearman@psc.com



## **Trane Technologies**

Jonathan Hoesch  
11937 Portal Rd  
La Vista, NE 68128  
Phone: (402) 499-8468  
jonathan.hoesch@trane.com



## **Wilkins Architecture, Design, Planning**

Jacob Sertich  
2908 W 39th St, Suite A  
Kearney, NE 68845  
Phone: (308) 237-5787  
jsertich@wilkinsadp.com

**One of the benefits for our Purple Ribbon Partners is the opportunity to submit an article for the monthly Member Update.** This month we proudly recognize:

# VOSS

L I G H T I N G • D E S I G N • S E R V I C E S

## Voss - A Nebraska Company since 1939

Voss is a trusted lighting solutions and services provider in North America. While Nebraska is where it all began for Voss in 1939, today we have 14 Branches located across the country. We work with school districts, building owners, property managers, government, and corporations to deliver tailored lighting and energy solutions.

We provide our customers with solutions that offer a positive impact to their operating expenses due to rising energy costs and outdated lighting systems. And for school districts, Voss has become a trusted partner to assist in improving their learning environments, creating excitement and pride on their campuses and throughout the community and addressing their safety and security concerns.



### ***More Than Just Illumination***

At Voss **we look holistically and think financially** when asked to survey school buildings for improved lighting.

- Our recommendations go beyond products and services to also include funding options so school districts can do more with less.
- We look beyond just lighting and bundle other facility improvements when it makes good business sense.
- Our financial focus means Districts can be assured we will do our due diligence and look for grants, tax incentives, unrealized assets and cost reallocation opportunities so their investment is as low as possible. And in many instances, budget neutral or positive cash flow.
- We have a dedicated controls division providing solutions to conserve energy, instill game day excitement and enhance the learning environment in school buildings across the state.
- Our experience designing exterior, color lighting solutions provides school districts with the opportunity to partner with Voss to add excitement and pride not just for their buildings, but the community as well.
- We work alongside Districts' preferred contractors to add value by doing an in-depth analysis of school buildings' indoor environments. This extra step makes sure the right products are selected and installed, saving Districts' money now and through the life of the products.
- We also work alongside District's Design Partner to add value by recommending products based on availability now and in the future, durability and life expectancy, controls compatibility and much more.

## VOSS

*Bringing a better light to our world, since 1939.*

**VOSSLIGHTING.COM**

**To learn more, please contact Randy Herrick.  
402-850-9789 or [randy.herrick@vossighting.com](mailto:randy.herrick@vossighting.com)**

# MEMBER SPOTLIGHT

## Loomis Public Schools



**Mascot:** Wolves

**Enrollment:** 275

**Location(s):** Loomis, NE

**Interesting Fact:** Loomis has grown in enrollment the past 11 years going from 190 students in 2013 to 275 in 2024. The addition of our PK program has started the new-young students on a recipe of success. Loomis Public School supplying education since 1896.

**Superintendent:** Sam Dunn

**Principal:** Nate Weaver

**Board of Education:** Allan Meyer - President, Scott Schukar - Vice President, Duane Schoff - Secretary, Luke Thorell - Treasurer, Mike Szekely, & Kelly Anderson

We have one of the best Beef in Schools program in our area. Local donors provide fresh beef for our school meals and it is served 5 times every 2-weeks. We have a monthly Hamburger Grill Day that is popular with our students and staff. Honor Roll students are rewarded once per semester and are feed steaks for their efforts. We have had over 15 local donors over the past 8 years of the span of this program. Money is donated through Phelps County Give 2 Grow to cover the cost of processing.



Our students have scored in the top of our ESU area in state testing the past 11 years. The dedication of our students and staff working hard and testing well has set the culture during the 11 years I have been an administrator at Loomis. Academically and Athletically Loomis excels!



**WOLVES**  
ACT SCORES 28 OR HIGHER

NAME	SCORE	NAME	SCORE
ADAM ALBY	38	ANTHONY KING	38
ANDREW BOND	38		
DAVID BOND	38		
BRITTA BOSTMAN	38		
JAY BOSTMAN	38		
ERIKAL BOSTMAN	38		
TERESA NELSON	38		
JANAYAN MONTGOMERY	38		
ERINNA LARSON	38		
TODD SMITH	38		
ETHEL SANDERSON	38		
JOHN WOLFE	38		
THOMAS CHAMBERLAIN	38		
ALTHEA BOSTMAN	38		
JULIA MOORE	38		
NOLAN STELLARIN	38		
DAVID EDGAL	38		
MONICA CRUSE	38		
CHRIS SHANNON	38		
CODY SANDERSON	38		
AMBER COLLIE	38		
HEATHER HORN	38		
LAYLARA SELL	38		



# MEMBER SPOTLIGHT

## Stuart Public Schools



Superintendent: **Robert Hanzlik**



Principal: **Travis Ludwig**

Board of Education: **Mike Stracke, Eric Kohle, Darby Paxton, Jared Wolf, Marvin Miksch, & Kurt Kaup**



**Mascot:** Broncos

**Enrollment:** 200 Students PK-12

**Locations:** Stuart, NE

**Interesting Fact:** The 2023 addition eliminated the use of a three-story building built over 100 years ago. The 17,675 square foot addition greatly added space to house a new shop to meet the needs of students wishing to enhance their hands-on learning in the areas of welding, metal fabrication, woodworking, and other agricultural-based tasks. Additionally, a larger music room complete with practice rooms was completed. A final aspect of the 2023 construction project was a renovation of the school library, art room, and assorted classrooms. The addition was supported by the passage of a district bond which passed in 2022 by a 3 to 1 margin after not passing in 2019.



## Programs

**Speech**---The Stuart Speech team has had a great deal of success at both the local and state level with the team claiming Class D2 State Titles in 2023, 2022 and 2021. This is in addition to state championships in 2005, 2010, 2014 and a State Runner-up in 2013.



**FFA**--The Stuart FFA Chapter chartered in 1999 and has established itself as a strong program in district, state and national competitions. The chapter is home to a National FFA Officer, three State FFA Officers, six National Proficiency Finalists and one National Champion, a 4th Place National Extemporaneous Speaker, a 5th place National Conduct of Chapter Meetings Team, a National Creed speaking medalist and a National Sr. Parliamentary Procedure Team competitor. In addition, the chapter has had 43 American Degree recipients, 103 State Degree recipients, 32 State Star Finalists and four State Stars over Nebraska. The members have greatly excelled in Leadership



# MEMBER SPOTLIGHT

## *Meridian Public Schools*



**Mascot:** Mustangs

**Enrollment:** 214 students

**Locations:** Daykin, NE

**Interesting Fact:** Meridian's school name honors the early and historic community of Meridian, Nebraska in the area. The Meridian Bridge is a nearby landmark of the area and has become a favorite attraction of Meridian's history.

**Superintendent: Randy Kort**



**Principals:** 7-12; Alex Hull, PK-6; Leslie Drees

**Board of Education:** Jason Bartels, Scott Sobotka, Jamie Niederklein, Brian Rutt, Rene Scheer, & Joy Barton



## Programs

Program 1. The Meridian Volleyball team has been district champions/state qualifiers for the past two years. This past year they place 4th at the state tournament, and they also won the Crossroads Conference Tournament. In 2022 the Volleyball team won the MUDECAS class B division tournament.



Program 2. Meridian FFA Chapter started in the 2018-2019 school year. The chapter has grown to 54 members. This year the first member of the chapter earned her National FFA Degree.



**I would encourage districts to consider participating in the Academic Decathlon competition.**

Academic Decathlon is an activity that is dependent on students of different ability levels. A team is made up of students who are in the Honors (A average), Scholastic (B average), and Varsity (C average) levels. Students may move up, but they may not move down. The combined scores of the students in all 10 competition events are counted, thus each team member is very important. There is a defined course of study in each subject area each year. Subject areas are commonly Math, Language & Literature, Science, Social Science, Economics, Art, and Music which are covered in the Regional competition each year. At the State Competition, Speech, Interview, and Essay are added. There is a “theme” each year that many of the subject areas cover. The theme for 2022-23 was the American Revolution. The theme for 2023-24 will be “Technology and Humanity”. Regional competition takes place in January and State competition takes place in February. The school can decide how to prepare for the competitions. Some schools have teams that have practices in the evenings or after school. Some simply provide the students with materials to study prior to competitions. Other schools offer a class to prepare.

Quiz Bowls are wonderful and fun activities, but they do not have a defined course of study like the Academic Decathlon. I find the Decathlon to be the best academic competition that I have experienced. To me, it is based on true study and learning.

On a personal note, three of my four kids participated in Academic Decathlon through high school and between them they won thousands of dollars in scholarships as they were on teams that had success. I currently serve on the Nebraska Academic Decathlon Board of Directors. I have been very involved with this activity for many years and highly encourage you to consider adding it to your school. A new school can have its enrollment fee waived the first year and may receive free study materials.

If you have any questions or have a staff member who is interested, please feel free to contact me. You could also contact the State Director, Vicki Deniston-Reed at [dcthln.denistonreed@gmail.com](mailto:dcthln.denistonreed@gmail.com).

---

**UNL Tuition Discount & GOLD Grant.**

We have a new tuition discount program aimed at better serving folks from rural districts who are seeking school leadership degrees (MEd – principalship, EdD – superintendency) or endorsements. The program

provides a 15% tuition discount for educators who serve in NRCSA member districts or are in an area classified by NCES as rural or town. We think this is a small but important step toward helping rural schools be intentional about growing their own leaders. If interested, please contact Dr. Nick Pace at [nick.pace@unl.edu](mailto:nick.pace@unl.edu)

**[Big Red Leader Website](#)**

**[Big Red Leadership Flyer](#)**

**In addition, invite your participation in a federal grant application aimed at helping Nebraska school districts. Led by the UNL Department of Educational Administration, the *Growth-Oriented Leadership Development (GOLD) Project* is a collaboration across NCSA, NRCSA, ESUCC, and NDE. Goals include:**

- Developing current and future leaders in a grow-your-own model
- Strengthening School Leadership
- Improving Principal and Teacher Retention

***GOLD Highlights:***

- A focus on local, building/district level context, not a top-down, one-size-fits-all approach
- Research-based content aligned with Marzano’s Balanced Leadership and other recent work
- Use of existing professional development structures led by credible leaders and coaches
- No additional costs or duties to ESUs or districts

***GOLD Includes:***

- Regular, large group professional development for the principal and 2-3 teacher leaders per building
- Small group coaching and facilitation provided by grant-funded coaches
- Application of material presented in sessions to local school improvement priorities and integration with the new NDE Nebraska Teacher and Principal Professional Standards (NTPPS)
- A stipend to participating schools to support implementation of GOLD dimensions and materials

To Learn More:

**<https://cehs.unl.edu/edad/gold-project/>**

---

## **Chadron State College Special Education Para-to-Teacher Program Initiative.**

**Purpose:** This “Grow Your Own” Special Education Teacher program is designed to provide school districts with the opportunity to cultivate and participate in the training of their para-professionals who wish to continue their education to become special education teachers.

**Who:** Any individual who holds a minimum of an Associate’s Degree (or equivalent credit hours) from an accredited higher education institution, and who is employed as a para-professional within a school district. **What:** Chadron State will provide required course work and enrichment activities via online, face-to-face (via Zoom), and on the job experiential learning, leading to a Bachelor’s in Education Degree, and a Nebraska Teaching Certificate with an endorsement in Special Education (grades PK-12). With administrator input, program course work will be tailored to best fit your district practices and expectations. Each course will be offered in an 8-week format, with 12-13 credit hours to be completed each 16 week semester.

**How:** Program participants will be advised, monitored, and supported by CSC faculty/staff, and a CSC Education Program liaison is specifically assigned to facilitate their progress. District para-professionals may enter the program at any time in the academic year.

**When:** once participants reach their senior academic year they will embark on completing their capstone course work, via online and Zoom class sessions. This course work has been pared down considerably with the understanding and assumption that these student teachers will be learning “on-the-job”. For example, one section covers classroom management practices. Clearly, one can argue and attest that these student teacher interns are learning more about managing a classroom from being mentored by veteran teachers within your school, and observing them in action. This is the belief and learning approach embraced during this senior year. However, to ensure and assess concept learning, Chadron State faculty will be meeting with your student teacher cohort twice per week for 1.5 hours, via Zoom conferencing technology.

**Graduation:** At the completion of this program students/candidates graduate from Chadron State College, and apply for teaching licensure resulting in a valid initial teaching certificate with and endorsement in PK-12 Special Education. Chadron State’s education program is nationally and State accredited. As such, interstate certification reciprocity is not a problem.

## **Things for your consideration:**

1) To qualify for this program participants must hold at least an Associate’s Degree or the equivalent in college credit hours. (*CSC will work with those applicants to provide them with the needed coursework leading up to program entry*).

2) Districts must agree to maintain para-professional employment throughout the course of the program—including during the student teaching experience.

Please contact Dr. Adam Fette for more program information, at [afette@csc.edu](mailto:afette@csc.edu).

---

## **The UNL Department of Educational Psychology has received a grant from the Swanson Foundation which allows them to offer mental health services to rural schools.**

From Dr. Michael Scheel, Chair of the UNL Department of Educational Psychology:

*The UNL Department of Educational Psychology would like to offer counseling and psychological services, as well as consultation services to the schools and communities of Southeast Nebraska. We run a mental health counseling and therapy clinic and we are offering counseling and consultation services to teachers, administrators, students, and community members of Southeast Nebraska. Services will be provided through remote and confidential means (i.e., Zoom conferencing). We are hoping that schools, families, and individuals contact us to schedule an appointment for a telehealth counseling or consultation session.*

*We have recently learned that a donor will support our work with individuals living in rural Southeast NE by paying all fees for services. Thus, whoever seeks out our services will simply have to indicate they live in Southeast Nebraska, and any services we provide will be paid for through the UNL Foundation. Individual, couple, and family counseling will be provided without financial expense. Additionally, we can provide teachers, school administrators, school counselors, and school social workers consultation services for students of their schools without charge.*

*We are very excited to enter a partnership with schools and communities of SE Nebraska to promote mental health and well-being. We are aware of the mental health counseling disparities that exist in Nebraska*

rural areas, and our department, our College of Education and Human Sciences, and UNL are highly interested in offering our expertise and resources with the goal of enhancing the well-being of SE Nebraska individuals, schools, and communities. We are a group comprised of licensed psychologists and psychology graduate students who regularly provide services through our clinic to the Lincoln community. We are seeking to reach beyond Lincoln to connect more with surrounding rural areas. We also are acutely aware of the importance of addressing mental health concerns right now as we all are experiencing the stress of going through the COVID-19 pandemic.

The Counseling and School Psychology Clinic is a training clinic in which graduate students in counseling and school psychology work with clients under the supervision of licensed psychologists. Services are available to all on a sliding scale. For clients from SE Nebraska communities, services will be paid for through UNL Foundation funds supplied by a donor who cares deeply about the welfare of schools and communities in SE Nebraska. Counseling services are offered to improve well-being, improve academic and behavioral issues, stabilize mood, manage stress, and improve life-adjustment issues.

For more information, please visit our clinic website:

<https://cehs.unl.edu/edpsych/clinic/>

**A common theme from some of the decision makers on the state level is that “out of control” local spending is to blame for the property tax problem.** NRCSA, along with many other educational entities, maintains that we do not have a school spending issue, but instead have a school funding issue. Attached are two reports, one from NRCSA, the other from Open Sky, that discuss the myth of “out of control” school spending. It is my hope that administrators and Board of Education members will read, then use these reports to counter those claims. When you do please tell your district’s story as that is the most powerful way to get this message across.

[NRCSA Spending Study](#)

[A Look at School Spending in NE from Open Sky](#)

## **SUPERINTENDENT SEARCH & PLANNING**

NRCSA has had a very successful year last year in assisting 14 Boards of Education in choosing their next Superintendent of Schools. Last year we were asked to assist Ansley Public Schools, Bruning-Davenport (interim), Educational Service Unit #16, Lakeview Community Schools, Louisville Public Schools, Medicine Valley Public Schools, North Bend Central Public Schools, Randolph Public Schools, Ravenna Public Schools, South Central Unified #5 (interim), Southwest Public Schools, Superior Public Schools (Interim), Tekamah-Herman Public Schools, and Thayer Central Public Schools in their searches for their next Superintendents. NRCSA was also selected to assist the NSAA Board of Directors in its search for the next Executive Director of the NSAA. We also assisted Thayer Central on a Principal search.

This year, we are already assisting the Boards of Education at Raymond Central and Sioux County in identifying their next Superintendent.

If your district finds a need to locate your next school leader, please be sure to keep the NRCSA Superintendent Search Service in mind. For more information you can contact Executive Director Jack Moles at [jmoles@nrca.net](mailto:jmoles@nrca.net) or by phone at 402-335-7732.

It is a common practice for many Boards of Education and the Superintendent to conduct short and long-term planning. NRCSA does provide a quality service using experienced consultants. If you are interested in more information, please contact Executive Director Jack Moles.



SYRACUSE-DUNBAR-AVOCA used the NRCSA Planning Service in 2022. NRCSA Consultants Rob Hanger and Fred Helmink assisted the district with its planning.

[NRCSA Search Service Experience](#)

[NRCSA Planning Support Brochure](#)

## Contact Information

---

### NRCSA

Jack Moles, Executive Director  
(402) 335-7732  
[jmoles@nrcea.net](mailto:jmoles@nrcea.net)

Jeff Bundy, Administrative Aide  
(402) 202-6028  
[jbundy@nrcea.net](mailto:jbundy@nrcea.net)

### Legislative Contacts

#### U.S. Senators

[Deb Fischer](#)

[Pete Ricketts](#)

#### U.S. House of Representatives

[Don Bacon](#)

[Mike Flood](#)

[Adrian Smith](#)

#### Nebraska Governor

[Jim Pillen](#)

#### NE State Senators

[Raymond Aguilar, Dist 35](#)

[Joni Albrecht, Dist 17](#)

[John Arch, Dist 14](#)

[Christy Armendariz, Dist 18](#)

[Beau Ballard, Dist 21](#)

[Carol Blood, Dist 3](#)

[Carolyn Bosn, Dist 25](#)

[Eliot Bostar, Dist 29](#)

[Bruce Bostelman, Dist 23](#)

[Tom Brandt, Dist 32](#)

[Tom Brewer, Dist 43](#)

[John Cavanaugh, Dist 9](#)

[Machaela Cavanaugh, Dist 6](#)

[Robert Clements, Dist 2](#)

[Danielle Conrad, Dist 46](#)

[Jen Day, Dist 49](#)

[Wendy DeBoer, Dist 10](#)

[Barry DeKay, Dist 40](#)

[Myron Dorn, Dist 30](#)

[Robert Dover, Dist 19](#)

[George Dugan, Dist 26](#)

[Steve Erdman, Dist 47](#)

[John Fredrickson, Dist 20](#)

[Steve Halloran, Dist 33](#)

[Ben Hansen, Dist 16](#)

[Brian Hardin, Dist 48](#)

[Rick Holderoft, Dist 36](#)

[Jana Hughes, Dist 24](#)

[Megan Hunt, Dist 8](#)

[Teresa Ibach, Dist 44](#)

[Mike Jacobson, Dist 42](#)

[Kathleen Kauth, Dist 31](#)

[Lou Ann Linehan, Dist 39](#)

[Loren Lippincott, Dist 34](#)

[John Lowe Sr., Dist 37](#)

[Mike McDonnell, Dist 5](#)

[Terrell McKinney, Dist 5](#)

[Fred Meyer, Dist 41](#)

[Mike Moser, Dist 22](#)

[Dave Murman, Dist 38](#)

[Jane Raybould, Dist 28](#)

[Merv, Riepe, Dist 12](#)

[Rita Sanders, Dist 45](#)

[Julie Slama, Dist 1](#)

[Tony Vargas, Dist 7](#)

[Brad Von Gillern, Dist 4](#)

[Lynne Walz, Dist 15](#)

[Justin Wayne, Dist 13](#)

[Anna Wishart, Dist 27](#)



## *NRCSA Programs*

**New Leaf Teletherapy**

**Planning Support Service**

**Scholarship and Awards Programs**

**Superintendent Search Service**

**USBank OneCard Program**



*NRCSA Rural Community Schools Association*  
*455 S 11th ST, Suite B*  
*Lincoln, NE 68508*



[www.nrca.net](http://www.nrca.net)



[www.twitter.com/NRCSA1980](https://www.twitter.com/NRCSA1980)



[www.facebook.com/nrcsahome/](https://www.facebook.com/nrcsahome/)

## Safety Report

8. Updating the paging system in Valparaiso and Jr/Sr High to be consistent with Ceresco system. The updates will allow for all phones to access the paging system on their respective campuses and/or across all campuses. Diode Technologies, who manages our phones, is the entity he is working with as they manage our phone system and the two would tie together. The quote to upgrade both buildings is \$8,509.56.
9. Consider adding a bell system and video feed on the PK3 classroom door to screen persons requesting entry. Currently, they need to look through the door window to grant entry.
10. Basketball Straps/Backboards/Mast. Tony had a vendor out to evaluate safety straps and our two main backboard systems in the competition gym. Our current backboards are not consistent with the current standards for backboards. Our mast system (the pole system that the backboard is attached to) and motor are very old and outdated. He indicated to us that it would cost around \$7000 to replace the mast system, replace the battery, replace the backboards and obtain the safety straps. This is on the premise that we can attach to the ceiling joists as they are.

## Facilities and Transportation Report

11. Land Lease - The board will be asked to approve a three year contract with Kyle and Jessica Schwarting for \$245/acre.
12. Backboards/masts/shot clocks/safety straps - The board will be asked to approve this purchase for \$15,283.08.
13. Heat Pumps - The board will be asked to approve a quote for heat pumps to be purchased from Mechanical Sales for no more than \$71,500 replacing the approval last month for no more than \$59,315.
14. Carpet Replacement Schedule - We are still waiting on one bid. This may get delayed until the March meeting.
15. Playground resurfacing - We are still in the process of obtaining updated quotes on resurfacing the main playground spaces at both elementary buildings.
16. Activity Bus - We received an email to indicate that the activity bus should be off the manufacturing line in July 2024 but then has to go and have air conditioning installed which takes about 4-5 weeks. It may not be here for the start of the fall activity season.
17. Electric Bus - Arrived yesterday. We will get it licensed and a radio installed then get it on a route as soon as possible.

## Technology Update

18. Access and Cameras - Most of the cabling is done at both elementary buildings. They will start on the cameras on Wednesday of this week and then start on installing the door hardware within two weeks. It takes about a day for a door so a week to a week and a half at each building for installing door hardware.

19. Field Sound System - Waiting on the speakers to arrive with installation to be complete prior to track season.
20. Technology eRate - We do have some eRate funds that we have to the end of this year to expend. The goal will be to purchase about \$45,000 in switches for the Jr/Sr building. eRate covers 50% of that cost. We would update the Jr/Sr building to ruckus switches which matches those that we replaced in the two elementary buildings last year. Switches and access points are typically a 5-7 year cycle item. Ruckus provides a more cost effective solution to switches as compared to the current Meraki switches (\$600 vs. \$4500).
21. Annual student and staff computer purchase is later in this agenda for approval.
22. The District hopes to purchase 2 interaction whiteboards per building per year to slowly replace projection systems in classrooms (where interactive boards are needed). This is later in the agenda for approval.

Important Upcoming Dates:

Board Committee Reports

Curriculum & American Civics Committee (Burklund-chair, Lange, Matulka)

Facilities & Transportation Committee (Matulka-chair, Burklund, Lange)

Finance Committee (Blanchard-chair, Breitreutz, Burklund)

Negotiations Committee (Blanchard-chair, Benes, Lange)

Policy Committee (Breitreutz-chair, Benes, Blanchard)

Old Business

Discuss, Consider and Take Necessary Action to approve an updated quote for heat pumps to be installed in the first of three phases at Valparaiso

A total of 29 heat pumps will need to be replaced at Valparaiso and will be done so in a 3-year plan. The schedule was adjusted to be better balanced as follows: year 1 (summer 2024)-12 first floor units; year 2 (summer 2025)-10 second floor units; and year 3 (summer 2026)-7 units (gym, art, music and kitchen). Motion by Burklund, second by Lange to approve the purchase of 12 heat pumps from Mechanical Sales not to exceed \$73,900 (\$71,400 plus \$2,500 for start up). This replaces the previous approval not to exceed \$59,315. RCV 4-0. Motion carried.



## SUBMITTAL DATA

Job Name	Raymond Central Elementary School
For	Water Source Heat Pumps
Sold To	Raymond Central Public Schools
Prepared For	Jared Shanahan
Customer PO#	
Prepared By	Brad McKewon
Date	2/8/2024

Job Information		Technical Data Sheet
Job Name	Valparaiso Elementary School	
Date	2/8/2024	
Submitted By	Brad McKewon	
Software Version	12.00	
Unit Tag	HP-104	



**Unit Overview**

Model Number	Voltage V/Hz/Phase	Airflow CFM	Fluid Flow gpm	Cooling Capacity Btu/hr	Cooling Efficiency EER@AHRI	Cooling Efficiency EER@Design	Heating Capacity Btu/hr	Heating Efficiency COP@AHRI	Heating Efficiency COP@Design
WGCH019	265/60/1	832	5.00	17392	16.6	14.2	16897	3.7	4.6

**Unit**

Model Number:	WGCH019		
Unit Type:	SmartSource Compact - Single Stage		
Approval:	ETL, CETL, AHRI		
Configuration	Refrigerant Type	Refrigerant Weight	Loop Temperature Range
Horizontal	R-410A	34.0 oz	Ground Loop (Geothermal)

**Unit Performance**

Air & Fluid Flow				
Airflow	Total External Static Pressure	Fluid Flow	Fluid Type	Altitude
832 CFM	0.30 inH <sub>2</sub> O	5.00 gpm	Water	0 ft

Cooling Performance										
Fluid Temperature		Air Temperature				Capacity		Heat of Rejection Btu/hr	EER @ design	Fluid Pressure Drop ft H <sub>2</sub> O
Entering °F	Leaving °F	Entering		Leaving		Total Btu/hr	Sensible Btu/hr			
		Dry Bulb °F	Wet Bulb °F	Dry Bulb °F	Wet Bulb °F					
85.0	93.6	78.0	65.0	62.6	58.0	17392	13943	21583	14.2	11.67

Heating Performance							
Fluid Temperature		Air Temperature		Capacity	Heat of Absorption Btu/hr	COP @ design	Fluid Pressure Drop ft H <sub>2</sub> O
Entering °F	Leaving °F	Entering	Leaving	Total Btu/hr			
		Dry Bulb °F	Dry Bulb °F				
40.0	34.7	70.0	88.7	16897	13254	4.6	12.90

**Electrical**

Unit Voltage	Minimum Voltage	Total Unit Full Load Current	Total Unit MCA
265/60/1	240 v	6.3 A	7.6 A
Compressor RLA	Compressor LRA	Motor FLA	Maximum Recommended Fuse Size / HACR Breaker Size
5.3 A	28.0 A	1.0 A	15 A

\*Short-Circuit Current = 5 kA rms symmetrical, 600 V maximum

**Physical**

Unit						
Length	Height	Width	Weight		Connection	
			Shipping	Operating	Water	Condensate
41.9 in	17.0 in	18.9 in	176 lb	150 lb	0.50 in	0.75 in

Fan	
Motor Type	Motor Horsepower
PSC - Standard Static	0.17 hp

Unit Options	
<b>Controls</b>	
Unit Control:	Microtech III
Control Transformer:	Standard 50 VA Transformer
Thermostat / Sensor Control:	Thermostat Control
<b>Unit Airflow Configuration</b>	
Return Air Location:	Right Hand
Discharge Air Location:	End

Construction Options	
<b>Drain Pan Material</b>	
Primary:	Stainless Steel
<b>Filters</b>	
Filter Rack Type:	Standard 1-inch 2-Sided
Filter Type:	1-inch Throwaway
(Quantity) Nominal Filter Dimensions:	(1) 25 in x 16 in x 1 in
<b>Insulation</b>	
Compressor Compartment:	1/2 inch Fiberglass, Skin-faced
Air Compartment:	1/2 inch Fiberglass, Skin-faced
<b>Miscellaneous</b>	
Coil Treatment:	None

Warranty	
Unit Warranty:	4 Yr Refrigerant Circuit Only Extended Parts Warranty, 1st Yr Labor Allowance

AHRI Certification	
	All equipment is rated and certified in accordance with AHRI / ISO 13256-1 and tested, investigated, and determined to comply with the requirements of the standards for Heating and Cooling Equipment UL 60335-2-40 Version 2 for the United States and CAN/CSA-C22.2 NO. 60335-2-40 Version 2 for Canada.

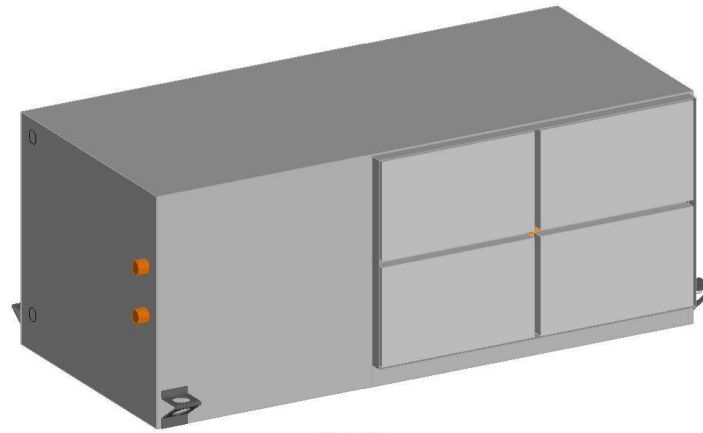

Model View

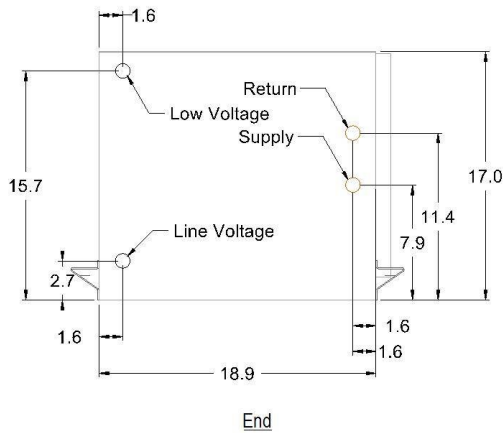

End

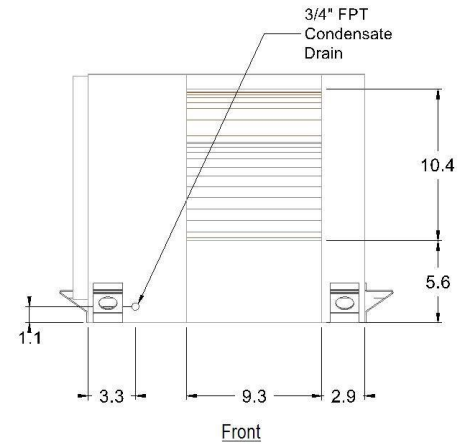

Front

**Product Drawing**

Product:

Model: WGCH019

Unit Tag: HP-104

Project Name: Valparaiso Elementary

Feb. 08, 2024

Ver/Rev:

Sheet: 1 of 1

Sales Office: Mechanical Sales, Inc.

Sales Engineer: Brad McKewon

Scale: NTS

Tolerance: +/- 0.25"

Dwg Units: (in)



13600 Industrial Park Blvd. Minneapolis, MN 55441  
www.DaikinApplied.com Software Version: 12.00

No change to this drawing may be made unless approved in writing by Daikin Applied. Purchaser must determine that the equipment is fit and sufficient for the job specifications.

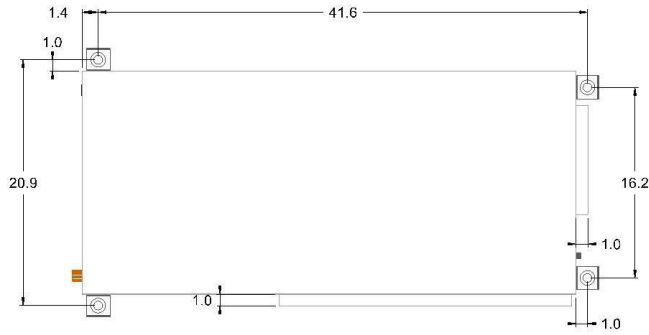

Top View



Bottom View

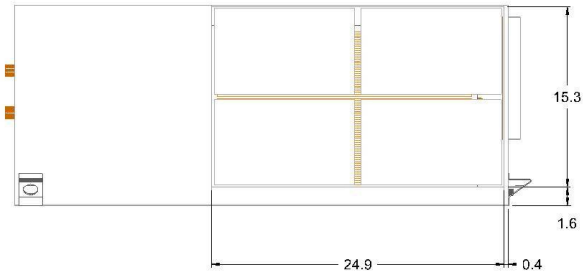

Left Side

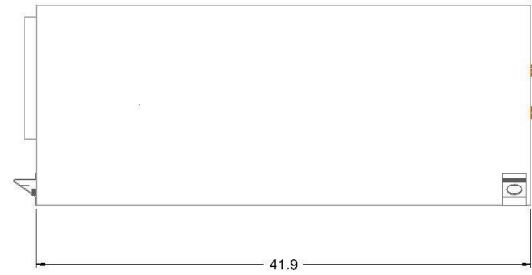

Right Side

**Product Drawing**

Unit Tag: HP-104

Sales Office: Mechanical Sales, Inc.

Product:

Project Name: Valparaiso Elementary

Sales Engineer: Brad McKewon

Model: WGCH019

Feb. 08, 2024

Ver/Rev:

Sheet: 1 of 1

Scale: NTS

Tolerance: +/- 0.25"

Dwg Units: (in)



13600 Industrial Park Blvd. Minneapolis, MN 55441  
www.DaikinApplied.com Software Version: 12.00

No change to this drawing may be made unless approved in writing by Daikin Applied. Purchaser must determine that the equipment is fit and sufficient for the job specifications.

Job Information		Technical Data Sheet
Job Name	Valparaiso Elementary School	
Date	2/8/2024	
Submitted By	Brad McKewon	
Software Version	12.00	
Unit Tag	HP-2	



Unit Overview									
Model Number	Voltage V/Hz/Phase	Airflow CFM	Fluid Flow gpm	Cooling Capacity Btu/hr	Cooling Efficiency EER@AHRI	Cooling Efficiency EER@Design	Heating Capacity Btu/hr	Heating Efficiency COP@AHRI	Heating Efficiency COP@Design
WGCH030	265/60/1	1136	7.00	25940	14.9	12.5	25069	3.2	2.9

Unit			
Model Number:	WGCH030		
Unit Type:	SmartSource Compact - Single Stage		
Approval:	ETL, CETL, AHRI		
Configuration	Refrigerant Type	Refrigerant Weight	Loop Temperature Range
Horizontal	R-410A	36.0 oz	Ground Loop (Geothermal)

**Unit Performance**

Air & Fluid Flow				
Airflow	Total External Static Pressure	Fluid Flow	Fluid Type	Altitude
1136 CFM	0.30 inH <sub>2</sub> O	7.00 gpm	Water	0 ft

Cooling Performance										
Fluid Temperature		Air Temperature				Capacity		Heat of Rejection Btu/hr	EER @ design	Fluid Pressure Drop ft H <sub>2</sub> O
Entering °F	Leaving °F	Entering		Leaving		Total Btu/hr	Sensible Btu/hr			
		Dry Bulb °F	Wet Bulb °F	Dry Bulb °F	Wet Bulb °F					
85.0	94.4	78.0	65.0	61.2	57.3	25940	20684	33011	12.5	12.79

Heating Performance							
Fluid Temperature		Air Temperature		Capacity Total Btu/hr	Heat of Absorption Btu/hr	COP @ design	Fluid Pressure Drop ft H <sub>2</sub> O
Entering °F	Leaving °F	Entering Dry Bulb °F	Leaving Dry Bulb °F				
40.0	35.3	70.0	90.3	25069	16332	2.9	14.13

**Electrical**

Unit Voltage	Minimum Voltage	Total Unit Full Load Current	Total Unit MCA
265/60/1	240 v	13.4 A	16.1 A
Compressor RLA	Compressor LRA	Motor FLA	Maximum Recommended Fuse Size / HACR Breaker Size
10.9 A	60.0 A	2.5 A	25 A

\*Short-Circuit Current = 5 kA rms symmetrical, 600 V maximum

**Physical**

Unit						
Length	Height	Width	Weight		Connection	
			Shipping	Operating	Water	Condensate
42.9 in	17.3 in	19.9 in	209 lb	182 lb	0.75 in	0.75 in

Fan	
Motor Type	Motor Horsepower
PSC - Standard Static	0.33 hp

Unit Options	
Controls	
Unit Control:	Microtech III
Control Transformer:	Standard 50 VA Transformer
Thermostat / Sensor Control:	Thermostat Control
Unit Airflow Configuration	
Return Air Location:	Left Hand
Discharge Air Location:	Straight

Construction Options	
Drain Pan Material	
Primary:	Stainless Steel
Filters	
Filter Rack Type:	Standard 1-inch 2-Sided
Filter Type:	1-inch Throwaway
(Quantity) Nominal Filter Dimensions:	(1) 24 in x 16 in x 1 in
Insulation	
Compressor Compartment:	1/2 inch Fiberglass, Skin-faced
Air Compartment:	1/2 inch Fiberglass, Skin-faced
Miscellaneous	
Coil Treatment:	None

Warranty	
Unit Warranty:	4 Yr Refrigerant Circuit Only Extended Parts Warranty, 1st Yr Labor Allowance

AHRI Certification	
	<p>All equipment is rated and certified in accordance with AHRI / ISO 13256-1 and tested, investigated, and determined to comply with the requirements of the standards for Heating and Cooling Equipment UL 60335-2-40 Version 2 for the United States and CAN/CSA-C22.2 NO. 60335-2-40 Version 2 for Canada.</p>

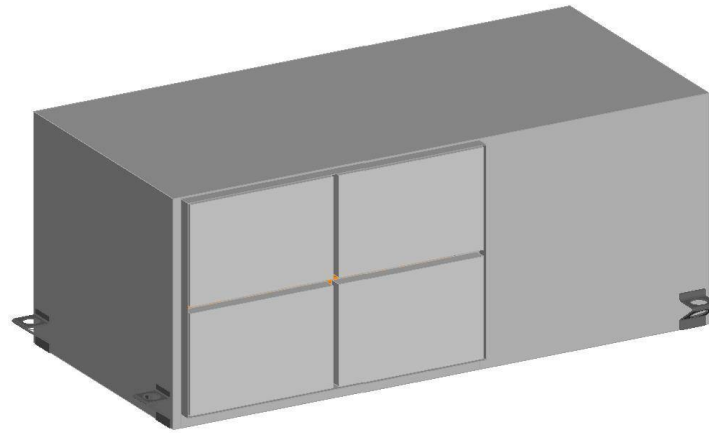

Model View

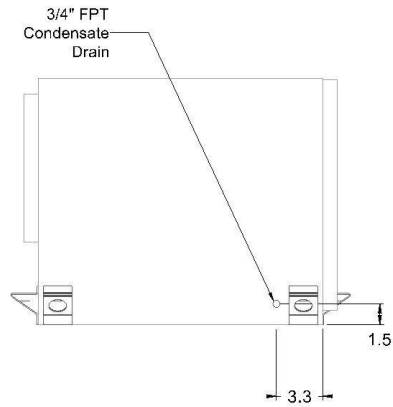

End

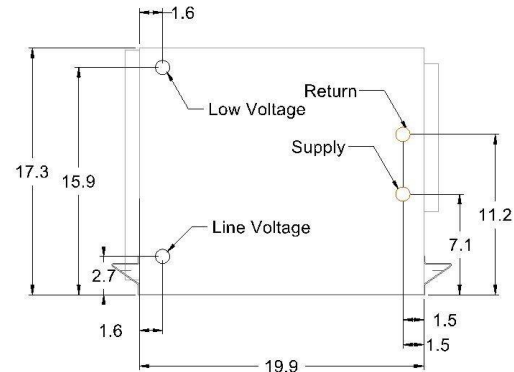

Front

**Product Drawing**

Unit Tag: HP-2

Sales Office: Mechanical Sales, Inc.

Product:

Project Name: Valparaiso Elementary

Sales Engineer: Brad McKewon

Model: WGCH030

Feb. 08, 2024

Ver/Rev:

Sheet: 1 of 1

Scale: NTS

Tolerance: +/- 0.25"

Dwg Units: (in)



13600 Industrial Park Blvd. Minneapolis, MN 55441  
 www.DaikinApplied.com Software Version: 12.00

No change to this drawing may be made unless approved in writing by Daikin Applied. Purchaser must determine that the equipment is fit and sufficient for the job specifications.

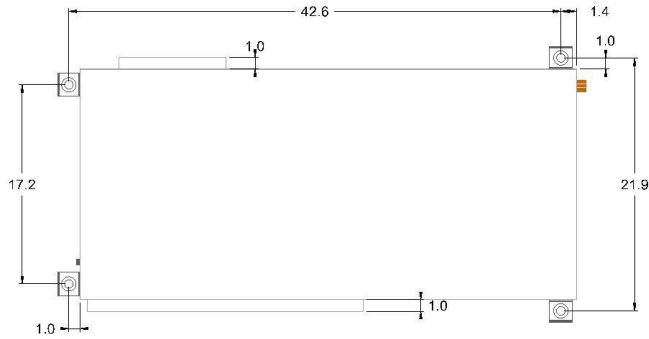

Top View



Bottom View

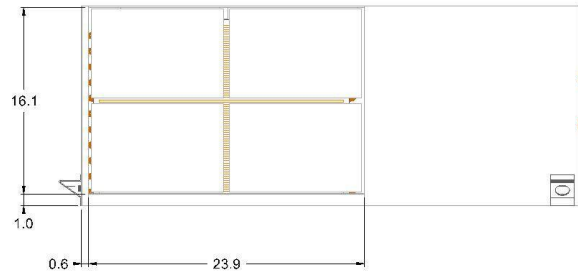

Left Side

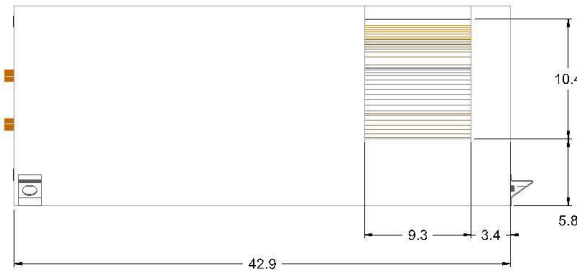

Right Side

**Product Drawing**

Product:  
Model: WGCH030

Unit Tag: HP-2

Project Name: Valparaiso Elementary

Feb. 08, 2024 Ver/Rev: Sheet: 1 of 1

Sales Office: Mechanical Sales, Inc.

Sales Engineer: Brad McKewon

Scale: NTS Tolerance: +/- 0.25" Dwg Units: (in)



13600 Industrial Park Blvd. Minneapolis, MN 55441  
www.DaikinApplied.com Software Version: 12.00

No change to this drawing may be made unless approved in writing by Daikin Applied. Purchaser must determine that the equipment is fit and sufficient for the job specifications.

Job Information		Technical Data Sheet
Job Name	Valparaiso Elementary School	
Date	2/8/2024	
Submitted By	Brad McKewon	
Software Version	12.00	
Unit Tag	HP-Locker	



Unit Overview									
Model Number	Voltage V/Hz/Phase	Airflow CFM	Fluid Flow gpm	Cooling Capacity Btu/hr	Cooling Efficiency EER@AHRI	Cooling Efficiency EER@Design	Heating Capacity Btu/hr	Heating Efficiency COP@AHRI	Heating Efficiency COP@Design
WGCH030	265/60/1	1136	7.00	25940	14.9	12.5	25069	3.2	2.9

Unit			
Model Number:	WGCH030		
Unit Type:	SmartSource Compact - Single Stage		
Approval:	ETL, CETL, AHRI		
Configuration	Refrigerant Type	Refrigerant Weight	Loop Temperature Range
Horizontal	R-410A	36.0 oz	Ground Loop (Geothermal)

**Unit Performance**

Air & Fluid Flow				
Airflow	Total External Static Pressure	Fluid Flow	Fluid Type	Altitude
1136 CFM	0.30 inH <sub>2</sub> O	7.00 gpm	Water	0 ft

Cooling Performance										
Fluid Temperature		Air Temperature				Capacity		Heat of Rejection Btu/hr	EER @ design	Fluid Pressure Drop ft H <sub>2</sub> O
Entering °F	Leaving °F	Entering		Leaving		Total Btu/hr	Sensible Btu/hr			
		Dry Bulb °F	Wet Bulb °F	Dry Bulb °F	Wet Bulb °F					
85.0	94.4	78.0	65.0	61.2	57.3	25940	20684	33011	12.5	12.79

Heating Performance							
Fluid Temperature		Air Temperature		Capacity Total Btu/hr	Heat of Absorption Btu/hr	COP @ design	Fluid Pressure Drop ft H <sub>2</sub> O
Entering °F	Leaving °F	Entering Dry Bulb °F	Leaving Dry Bulb °F				
40.0	35.3	70.0	90.3	25069	16332	2.9	14.13

**Electrical**

Unit Voltage	Minimum Voltage	Total Unit Full Load Current	Total Unit MCA
265/60/1	240 v	13.4 A	16.1 A
Compressor RLA	Compressor LRA	Motor FLA	Maximum Recommended Fuse Size / HACR Breaker Size
10.9 A	60.0 A	2.5 A	25 A

\*Short-Circuit Current = 5 kA rms symmetrical, 600 V maximum

**Physical**

Unit						
Length	Height	Width	Weight		Connection	
			Shipping	Operating	Water	Condensate
42.9 in	17.3 in	19.9 in	209 lb	182 lb	0.75 in	0.75 in

Fan	
Motor Type	Motor Horsepower
PSC - Standard Static	0.33 hp

Unit Options	
Controls	
Unit Control:	Microtech III
Control Transformer:	Standard 50 VA Transformer
Thermostat / Sensor Control:	Thermostat Control
Unit Airflow Configuration	
Return Air Location:	Right Hand
Discharge Air Location:	End

Construction Options	
Drain Pan Material	
Primary:	Stainless Steel
Filters	
Filter Rack Type:	Standard 1-inch 2-Sided
Filter Type:	1-inch Throwaway
(Quantity) Nominal Filter Dimensions:	(1) 24 in x 16 in x 1 in
Insulation	
Compressor Compartment:	1/2 inch Fiberglass, Skin-faced
Air Compartment:	1/2 inch Fiberglass, Skin-faced
Miscellaneous	
Coil Treatment:	None

Warranty	
Unit Warranty:	4 Yr Refrigerant Circuit Only Extended Parts Warranty, 1st Yr Labor Allowance

AHRI Certification	
	<p>All equipment is rated and certified in accordance with AHRI / ISO 13256-1 and tested, investigated, and determined to comply with the requirements of the standards for Heating and Cooling Equipment UL 60335-2-40 Version 2 for the United States and CAN/CSA-C22.2 NO. 60335-2-40 Version 2 for Canada.</p>

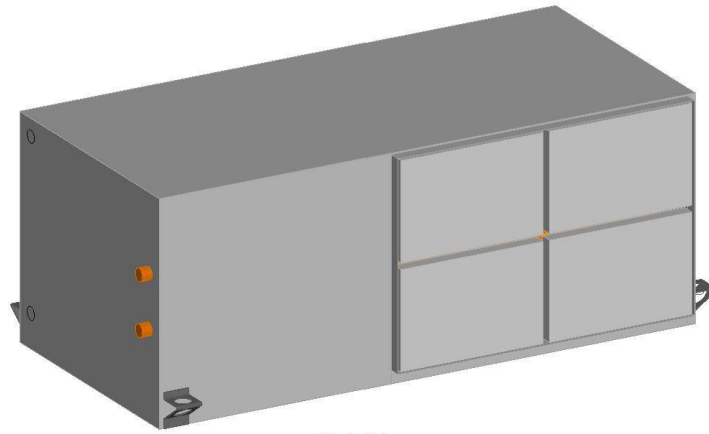

Model View

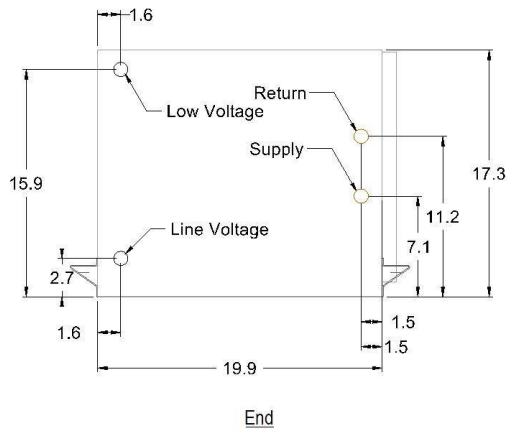

End

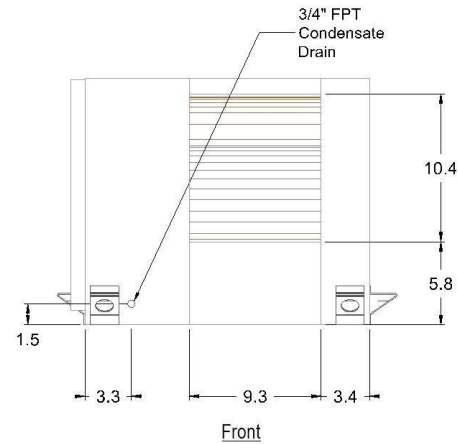

Front

<b>Product Drawing</b>		Unit Tag: HP-Locker			Sales Office: Mechanical Sales, Inc.			 13600 Industrial Park Blvd. Minneapolis, MN 55441 www.DaikinApplied.com Software Version: 12.00
Product:		Project Name: Valparaiso Elementary			Sales Engineer: Brad McKewon			
Model: WGCH030		Feb. 08, 2024	Ver/Rev:	Sheet: 1 of 1	Scale: NTS	Tolerance: +/- 0.25"	Dwg Units: (in)	

No change to this drawing may be made unless approved in writing by Daikin Applied. Purchaser must determine that the equipment is fit and sufficient for the job specifications.

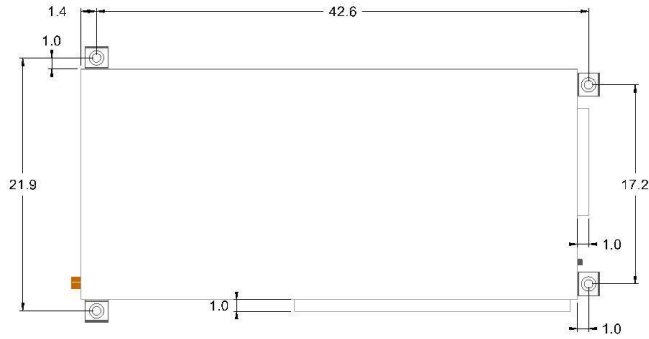

Top View



Bottom View

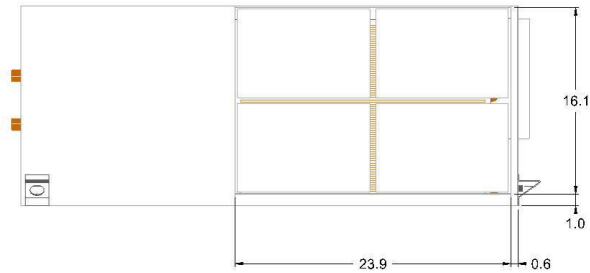

Left Side

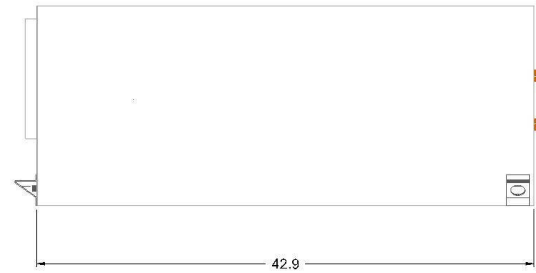

Right Side

**Product Drawing**

Product:

Model: WGCH030

Unit Tag: HP-Locker

Project Name: Valparaiso Elementary

Feb. 08, 2024

Ver/Rev:

Sheet: 1 of 1

Sales Office: Mechanical Sales, Inc.

Sales Engineer: Brad McKewon

Scale: NTS

Tolerance: +/- 0.25"

Dwg Units: (in)



13600 Industrial Park Blvd. Minneapolis, MN 55441  
 www.DaikinApplied.com Software Version: 12.00

No change to this drawing may be made unless approved in writing by Daikin Applied. Purchaser must determine that the equipment is fit and sufficient for the job specifications.

Job Information		Technical Data Sheet	
Job Name	Valparaiso Elementary School		
Date	2/8/2024		
Submitted By	Brad McKewon		
Software Version	12.00		
Unit Tag	HP-13		



Unit Overview									
Model Number	Voltage V/Hz/Phase	Airflow CFM	Fluid Flow gpm	Cooling Capacity Btu/hr	Cooling Efficiency EER@AHRI	Cooling Efficiency EER@Design	Heating Capacity Btu/hr	Heating Efficiency COP@AHRI	Heating Efficiency COP@Design
WGCH048	460/60/3	1713	11.00	45689	16.1	12.3	43818	3.5	3.6

Unit			
Model Number:	WGCH048		
Unit Type:	SmartSource Compact - Single Stage		
Approval:	ETL, CETL, AHRI		
Configuration	Refrigerant Type	Refrigerant Weight	Loop Temperature Range
Horizontal	R-410A	54.0 oz	Ground Loop (Geothermal)

**Unit Performance**

Air & Fluid Flow				
Airflow	Total External Static Pressure	Fluid Flow	Fluid Type	Altitude
1713 CFM	0.30 inH <sub>2</sub> O	11.00 gpm	Water	0 ft

Cooling Performance										
Fluid Temperature		Air Temperature				Capacity		Heat of Rejection Btu/hr	EER @ design	Fluid Pressure Drop ft H <sub>2</sub> O
Entering °F	Leaving °F	Entering		Leaving		Total Btu/hr	Sensible Btu/hr			
		Dry Bulb °F	Wet Bulb °F	Dry Bulb °F	Wet Bulb °F					
85.0	95.6	78.0	65.0	59.3	56.0	45689	34825	58406	12.3	8.79

Heating Performance							
Fluid Temperature		Air Temperature		Capacity Total Btu/hr	Heat of Absorption Btu/hr	COP @ design	Fluid Pressure Drop ft H <sub>2</sub> O
Entering °F	Leaving °F	Entering Dry Bulb °F	Leaving Dry Bulb °F				
40.0	34.3	70.0	93.6	43818	31571	3.6	9.71

**Electrical**

Unit Voltage	Minimum Voltage	Total Unit Full Load Current	Total Unit MCA
460/60/3	416 V	8.0 A	9.6 A
Compressor RLA	Compressor LRA	Motor FLA	Maximum Recommended Fuse Size / HACR Breaker Size
6.2 A	41.0 A	1.8 A	15 A

\*Short-Circuit Current = 5 kA rms symmetrical, 600 V maximum

**Physical**

Unit						
Length	Height	Width	Weight		Connection	
			Shipping	Operating	Water	Condensate
53.9 in	21.0 in	23.9 in	331 lb	296 lb	1.00 in	0.75 in

Fan	
Motor Type	Motor Horsepower
PSC - Standard Static	0.50 hp

Unit Options	
<b>Controls</b>	
Unit Control:	Microtech III
Control Transformer:	Standard 50 VA Transformer
Thermostat / Sensor Control:	Thermostat Control
<b>Unit Airflow Configuration</b>	
Return Air Location:	Right Hand
Discharge Air Location:	End

Construction Options	
<b>Drain Pan Material</b>	
Primary:	Stainless Steel
<b>Filters</b>	
Filter Rack Type:	Standard 1-inch 2-Sided
Filter Type:	1-inch Throwaway
(Quantity) Nominal Filter Dimensions:	(2) 16 in x 20 in x 1 in
<b>Insulation</b>	
Compressor Compartment:	1/2 inch Fiberglass, Skin-faced
Air Compartment:	1/2 inch Fiberglass, Skin-faced
<b>Miscellaneous</b>	
Coil Treatment:	None

Warranty	
Unit Warranty:	4 Yr Refrigerant Circuit Only Extended Parts Warranty, 1st Yr Labor Allowance

AHRI Certification	
	<p>All equipment is rated and certified in accordance with AHRI / ISO 13256-1 and tested, investigated, and determined to comply with the requirements of the standards for Heating and Cooling Equipment UL 60335-2-40 Version 2 for the United States and CAN/CSA-C22.2 NO. 60335-2-40 Version 2 for Canada.</p>

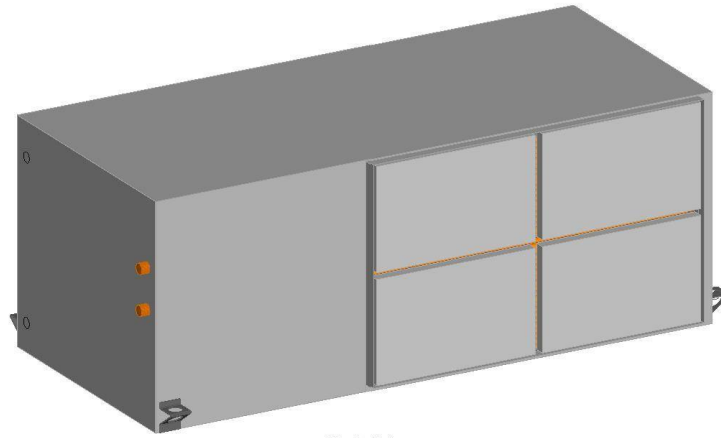

Model View

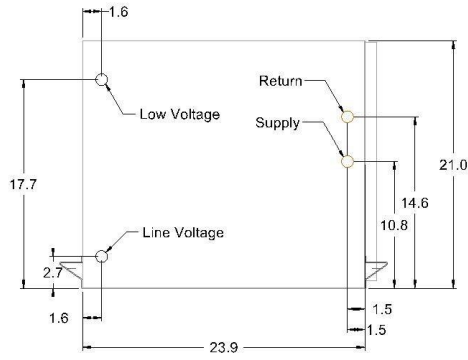

End

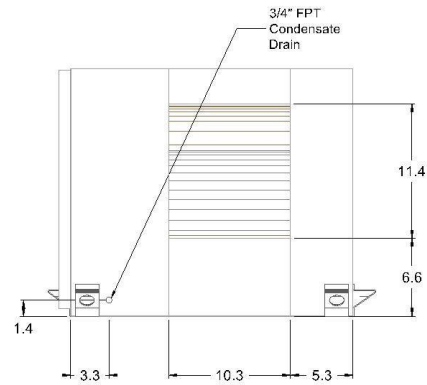

Front

**Product Drawing**

Unit Tag: HP-13

Sales Office: Mechanical Sales, Inc.

Product:

Project Name: Valparaiso Elementary

Sales Engineer: Brad McKewon

Model: WGCH048

Feb. 08, 2024

Ver/Rev:

Sheet: 1 of 1

Scale: NTS

Tolerance: +/- 0.25"

Dwg Units: (in)



13600 Industrial Park Blvd. Minneapolis, MN 55441  
 www.DaikinApplied.com Software Version: 12.00

No change to this drawing may be made unless approved in writing by Daikin Applied. Purchaser must determine that the equipment is fit and sufficient for the job specifications.

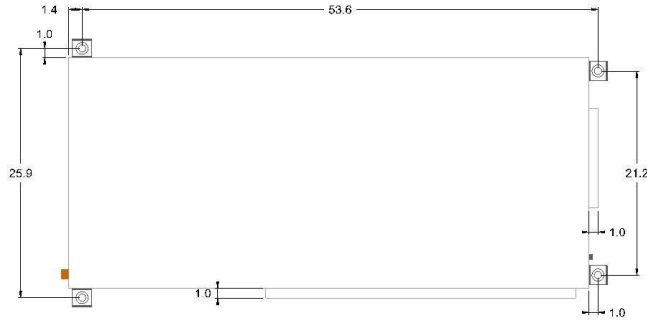

Top View



Bottom View

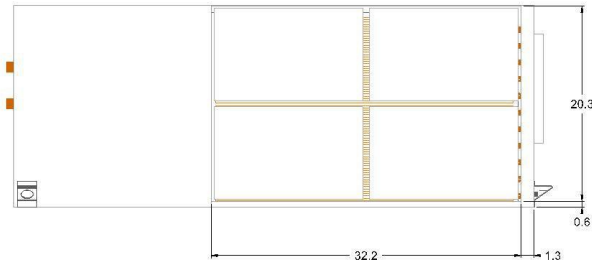

Left Side

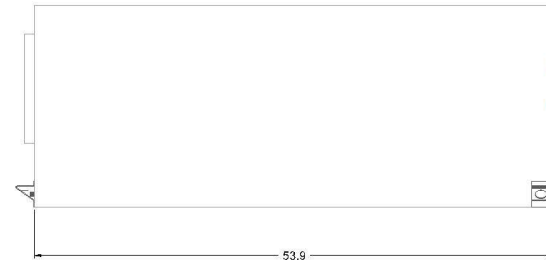

Right Side

**Product Drawing**

Unit Tag: HP-13

Sales Office: Mechanical Sales, Inc.

Product:

Project Name: Valparaiso Elementary

Sales Engineer: Brad McKewon

Model: WGCH048

Feb. 08, 2024

Ver/Rev:

Sheet: 1 of 1

Scale: NTS

Tolerance: +/- 0.25"

Dwg Units: (in)



13600 Industrial Park Blvd. Minneapolis, MN 55441  
www.DaikinApplied.com Software Version: 12.00

No change to this drawing may be made unless approved in writing by Daikin Applied. Purchaser must determine that the equipment is fit and sufficient for the job specifications.

Job Information		Technical Data Sheet	
Job Name	Valparaiso Elementary School		
Date	2/8/2024		
Submitted By	Brad McKewon		
Software Version	12.00		
Unit Tag	HP-14		



Unit Overview									
Model Number	Voltage V/Hz/Phase	Airflow CFM	Fluid Flow gpm	Cooling Capacity Btu/hr	Cooling Efficiency EER@AHRI	Cooling Efficiency EER@Design	Heating Capacity Btu/hr	Heating Efficiency COP@AHRI	Heating Efficiency COP@Design
WGCH048	460/60/3	1713	11.00	45689	16.1	12.3	43818	3.5	3.6

Unit			
Model Number:	WGCH048		
Unit Type:	SmartSource Compact - Single Stage		
Approval:	ETL, CETL, AHRI		
Configuration	Refrigerant Type	Refrigerant Weight	Loop Temperature Range
Horizontal	R-410A	54.0 oz	Ground Loop (Geothermal)

**Unit Performance**

Air & Fluid Flow				
Airflow	Total External Static Pressure	Fluid Flow	Fluid Type	Altitude
1713 CFM	0.30 inH <sub>2</sub> O	11.00 gpm	Water	0 ft

Cooling Performance										
Fluid Temperature		Air Temperature				Capacity		Heat of Rejection Btu/hr	EER @ design	Fluid Pressure Drop ft H <sub>2</sub> O
Entering °F	Leaving °F	Entering		Leaving		Total Btu/hr	Sensible Btu/hr			
		Dry Bulb °F	Wet Bulb °F	Dry Bulb °F	Wet Bulb °F					
85.0	95.6	78.0	65.0	59.3	56.0	45689	34825	58406	12.3	8.79

Heating Performance							
Fluid Temperature		Air Temperature		Capacity Total Btu/hr	Heat of Absorption Btu/hr	COP @ design	Fluid Pressure Drop ft H <sub>2</sub> O
Entering °F	Leaving °F	Entering Dry Bulb °F	Leaving Dry Bulb °F				
40.0	34.3	70.0	93.6	43818	31571	3.6	9.71

**Electrical**

Unit Voltage	Minimum Voltage	Total Unit Full Load Current	Total Unit MCA
460/60/3	416 V	8.0 A	9.6 A
Compressor RLA	Compressor LRA	Motor FLA	Maximum Recommended Fuse Size / HACR Breaker Size
6.2 A	41.0 A	1.8 A	15 A

\*Short-Circuit Current = 5 kA rms symmetrical, 600 V maximum

**Physical**

Unit						
Length	Height	Width	Weight		Connection	
			Shipping	Operating	Water	Condensate
53.9 in	21.0 in	23.9 in	331 lb	296 lb	1.00 in	0.75 in

Fan	
Motor Type	Motor Horsepower
PSC - Standard Static	0.50 hp

Unit Options	
<b>Controls</b>	
Unit Control:	Microtech III
Control Transformer:	Standard 50 VA Transformer
Thermostat / Sensor Control:	Thermostat Control
<b>Unit Airflow Configuration</b>	
Return Air Location:	Left Hand
Discharge Air Location:	End

Construction Options	
<b>Drain Pan Material</b>	
Primary:	Stainless Steel
<b>Filters</b>	
Filter Rack Type:	Standard 1-inch 2-Sided
Filter Type:	1-inch Throwaway
(Quantity) Nominal Filter Dimensions:	(2) 16 in x 20 in x 1 in
<b>Insulation</b>	
Compressor Compartment:	1/2 inch Fiberglass, Skin-faced
Air Compartment:	1/2 inch Fiberglass, Skin-faced
<b>Miscellaneous</b>	
Coil Treatment:	None

Warranty	
Unit Warranty:	4 Yr Refrigerant Circuit Only Extended Parts Warranty, 1st Yr Labor Allowance

AHRI Certification	
	All equipment is rated and certified in accordance with AHRI / ISO 13256-1 and tested, investigated, and determined to comply with the requirements of the standards for Heating and Cooling Equipment UL 60335-2-40 Version 2 for the United States and CAN/CSA-C22.2 NO. 60335-2-40 Version 2 for Canada.

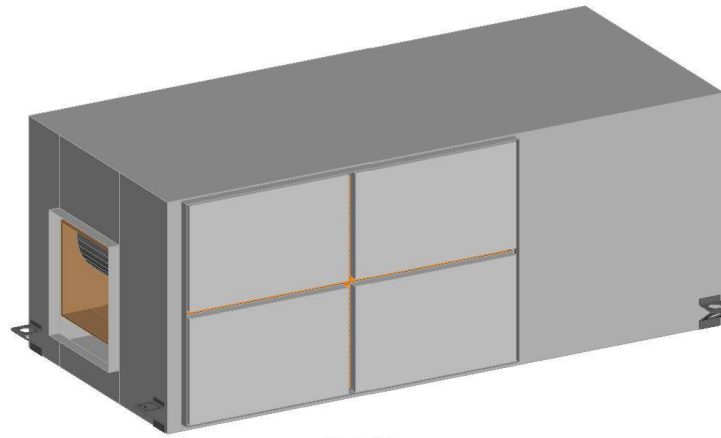

Model View

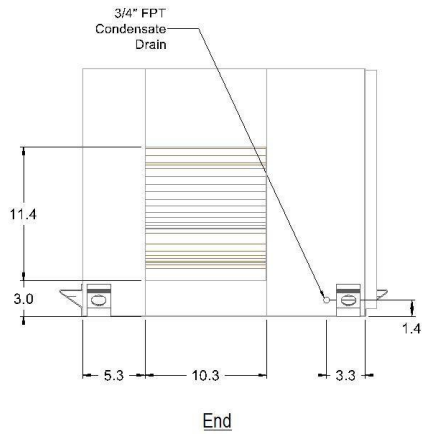

End

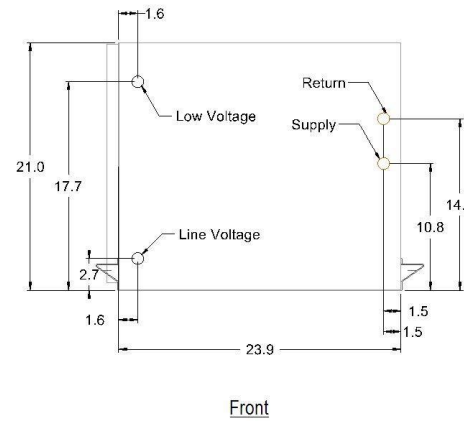

Front

<b>Product Drawing</b>	Unit Tag: HP-14	Sales Office: Mechanical Sales, Inc.			 13600 Industrial Park Blvd. Minneapolis, MN 55441 www.DaikinApplied.com Software Version: 12.00	
Product:	Project Name: Valparaiso Elementary	Sales Engineer: Brad McKewon				
Model: WGCH048	Feb. 08, 2024	Ver/Rev:	Sheet: 1 of 1	Scale: NTS	Tolerance: +/- 0.25"	Dwg Units: (in)

No change to this drawing may be made unless approved in writing by Daikin Applied. Purchaser must determine that the equipment is fit and sufficient for the job specifications.

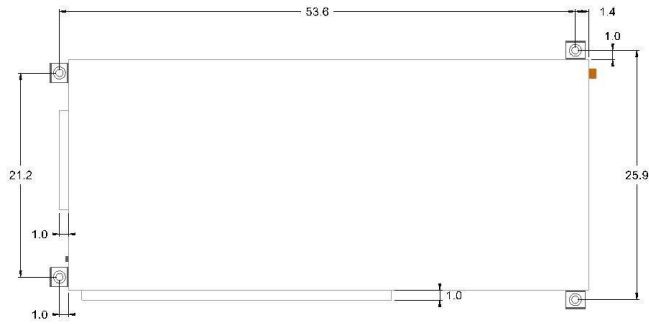

Top View



Bottom View

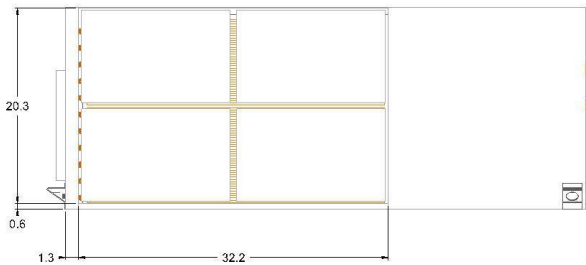

Left Side

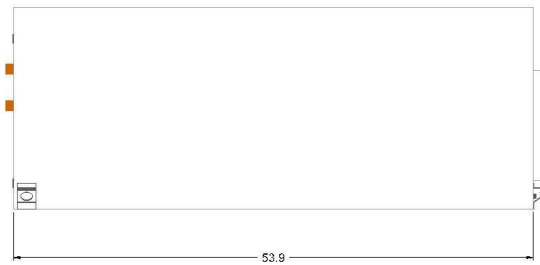

Right Side

**Product Drawing**

Product:

Model: WGCH048

Unit Tag: HP-14

Project Name: Valparaiso Elementary

Feb. 08, 2024

Ver/Rev:

Sheet: 1 of 1

Sales Office: Mechanical Sales, Inc.

Sales Engineer: Brad McKewon

Scale: NTS

Tolerance: +/- 0.25"

Dwg Units: (in)



13600 Industrial Park Blvd. Minneapolis, MN 55441  
 www.DaikinApplied.com Software Version: 12.00

No change to this drawing may be made unless approved in writing by Daikin Applied. Purchaser must determine that the equipment is fit and sufficient for the job specifications.

Job Information		Technical Data Sheet
Job Name	Valparaiso Elementary School	
Date	2/8/2024	
Submitted By	Brad McKewon	
Software Version	12.00	
Unit Tag	HP-15	



**Unit Overview**

Model Number	Voltage V/Hz/Phase	Airflow CFM	Fluid Flow gpm	Cooling Capacity Btu/hr	Cooling Efficiency EER@AHRI	Cooling Efficiency EER@Design	Heating Capacity Btu/hr	Heating Efficiency COP@AHRI	Heating Efficiency COP@Design
WGCH048	460/60/3	1713	11.00	45689	16.1	12.3	43818	3.5	3.6

**Unit**

Model Number:	WGCH048		
Unit Type:	SmartSource Compact - Single Stage		
Approval:	ETL, CETL, AHRI		
Configuration	Refrigerant Type	Refrigerant Weight	Loop Temperature Range
Horizontal	R-410A	54.0 oz	Ground Loop (Geothermal)

**Unit Performance**

Air & Fluid Flow				
Airflow	Total External Static Pressure	Fluid Flow	Fluid Type	Altitude
1713 CFM	0.30 inH <sub>2</sub> O	11.00 gpm	Water	0 ft

Cooling Performance										
Fluid Temperature		Air Temperature				Capacity		Heat of Rejection Btu/hr	EER @ design	Fluid Pressure Drop ft H <sub>2</sub> O
Entering °F	Leaving °F	Entering		Leaving		Total Btu/hr	Sensible Btu/hr			
		Dry Bulb °F	Wet Bulb °F	Dry Bulb °F	Wet Bulb °F					
85.0	95.6	78.0	65.0	59.3	56.0	45689	34825	58406	12.3	8.79

Heating Performance							
Fluid Temperature		Air Temperature		Capacity Total Btu/hr	Heat of Absorption Btu/hr	COP @ design	Fluid Pressure Drop ft H <sub>2</sub> O
Entering °F	Leaving °F	Entering	Leaving				
		Dry Bulb °F	Dry Bulb °F				
40.0	34.3	70.0	93.6	43818	31571	3.6	9.71

**Electrical**

Unit Voltage	Minimum Voltage	Total Unit Full Load Current	Total Unit MCA
460/60/3	416 V	8.0 A	9.6 A
Compressor RLA	Compressor LRA	Motor FLA	Maximum Recommended Fuse Size / HACR Breaker Size
6.2 A	41.0 A	1.8 A	15 A

\*Short-Circuit Current = 5 kA rms symmetrical, 600 V maximum

**Physical**

Unit						
Length	Height	Width	Weight		Connection	
			Shipping	Operating	Water	Condensate
53.9 in	21.0 in	23.9 in	331 lb	296 lb	1.00 in	0.75 in

Fan	
Motor Type	Motor Horsepower
PSC - Standard Static	0.50 hp

Unit Options	
<b>Controls</b>	
Unit Control:	Microtech III
Control Transformer:	Standard 50 VA Transformer
Thermostat / Sensor Control:	Thermostat Control
<b>Unit Airflow Configuration</b>	
Return Air Location:	Right Hand
Discharge Air Location:	End

Construction Options	
<b>Drain Pan Material</b>	
Primary:	Stainless Steel
<b>Filters</b>	
Filter Rack Type:	Standard 1-inch 2-Sided
Filter Type:	1-inch Throwaway
(Quantity) Nominal Filter Dimensions:	(2) 16 in x 20 in x 1 in
<b>Insulation</b>	
Compressor Compartment:	1/2 inch Fiberglass, Skin-faced
Air Compartment:	1/2 inch Fiberglass, Skin-faced
<b>Miscellaneous</b>	
Coil Treatment:	None

Warranty	
Unit Warranty:	4 Yr Refrigerant Circuit Only Extended Parts Warranty, 1st Yr Labor Allowance

AHRI Certification	
	All equipment is rated and certified in accordance with AHRI / ISO 13256-1 and tested, investigated, and determined to comply with the requirements of the standards for Heating and Cooling Equipment UL 60335-2-40 Version 2 for the United States and CAN/CSA-C22.2 NO. 60335-2-40 Version 2 for Canada.

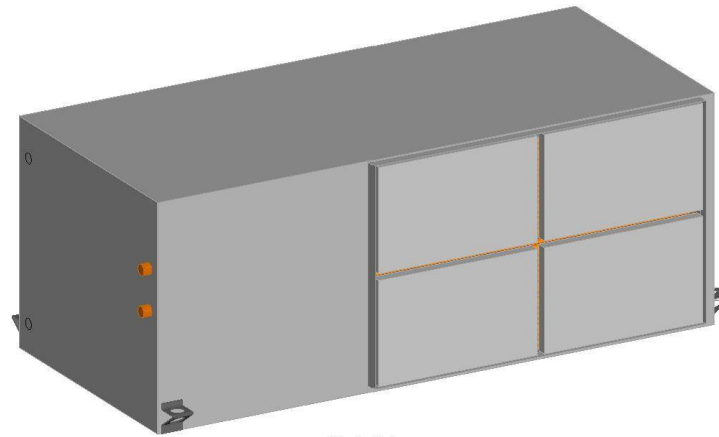

Model View

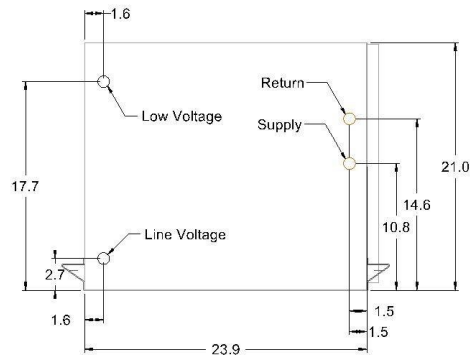

End

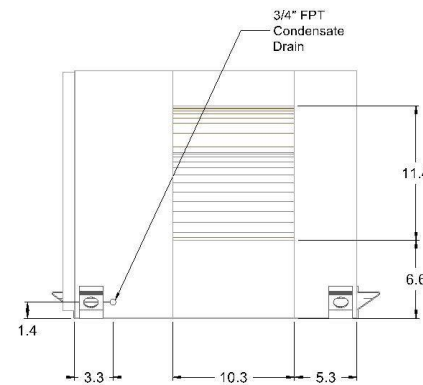

Front

<b>Product Drawing</b>		Unit Tag: HP-15			Sales Office: Mechanical Sales, Inc.			 13600 Industrial Park Blvd. Minneapolis, MN 55441 www.DaikinApplied.com Software Version: 12.00
Product:		Project Name: Valparaiso Elementary			Sales Engineer: Brad McKewon			
Model: WGCH048		Feb. 08, 2024	Ver/Rev:	Sheet: 1 of 1	Scale: NTS	Tolerance: +/- 0.25"	Dwg Units: (in)	

No change to this drawing may be made unless approved in writing by Daikin Applied. Purchaser must determine that the equipment is fit and sufficient for the job specifications.

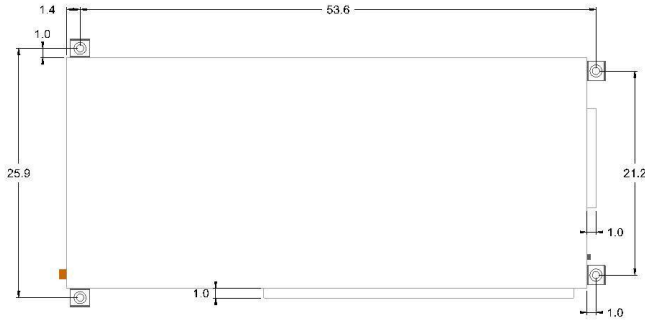

Top View

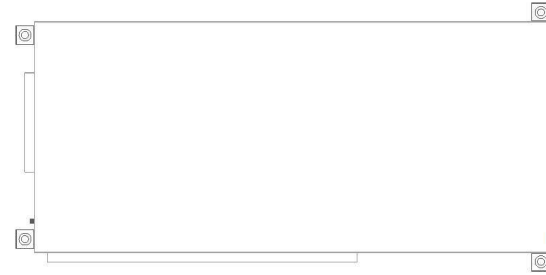

Bottom View

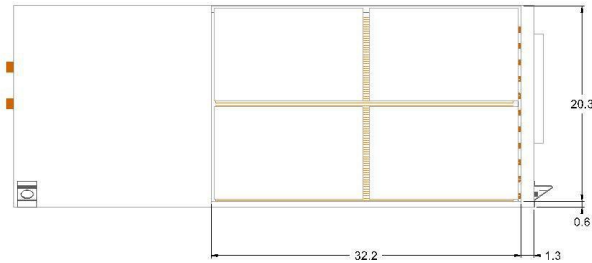

Left Side

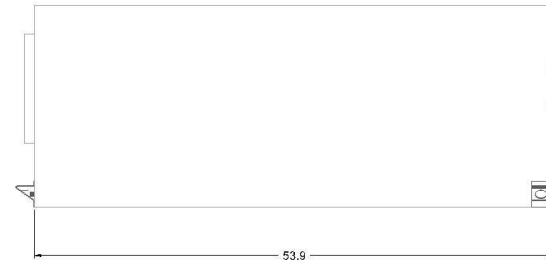

Right Side

**Product Drawing**

Product:

Model: WGCH048

Unit Tag: HP-15

Project Name: Valparaiso Elementary

Feb. 08, 2024

Ver/Rev:

Sheet: 1 of 1

Sales Office: Mechanical Sales, Inc.

Sales Engineer: Brad McKewon

Scale: NTS

Tolerance: +/- 0.25"

Dwg Units: (in)



13600 Industrial Park Blvd. Minneapolis, MN 55441  
 www.DaikinApplied.com Software Version: 12.00

No change to this drawing may be made unless approved in writing by Daikin Applied. Purchaser must determine that the equipment is fit and sufficient for the job specifications.

Job Information		Technical Data Sheet	
Job Name	Valparaiso Elementary School		
Date	2/8/2024		
Submitted By	Brad McKewon		
Software Version	12.00		
Unit Tag	HP-Principal		



**Unit Overview**

Model Number	Voltage V/Hz/Phase	Airflow CFM	Fluid Flow gpm	Cooling Capacity Btu/hr	Cooling Efficiency EER@AHRI	Cooling Efficiency EER@Design	Heating Capacity Btu/hr	Heating Efficiency COP@AHRI	Heating Efficiency COP@Design
WGCH048	460/60/3	1713	11.00	45689	16.1	12.3	43818	3.5	3.6

**Unit**

Model Number:	WGCH048		
Unit Type:	SmartSource Compact - Single Stage		
Approval:	ETL, CETL, AHRI		
Configuration	Refrigerant Type	Refrigerant Weight	Loop Temperature Range
Horizontal	R-410A	54.0 oz	Ground Loop (Geothermal)

**Unit Performance**

Air & Fluid Flow				
Airflow	Total External Static Pressure	Fluid Flow	Fluid Type	Altitude
1713 CFM	0.30 inH <sub>2</sub> O	11.00 gpm	Water	0 ft

Cooling Performance										
Fluid Temperature		Air Temperature				Capacity		Heat of Rejection Btu/hr	EER @ design	Fluid Pressure Drop ft H <sub>2</sub> O
Entering °F	Leaving °F	Entering		Leaving		Total Btu/hr	Sensible Btu/hr			
		Dry Bulb °F	Wet Bulb °F	Dry Bulb °F	Wet Bulb °F					
85.0	95.6	78.0	65.0	59.3	56.0	45689	34825	58406	12.3	8.79

Heating Performance								
Fluid Temperature		Air Temperature		Capacity Total Btu/hr	Heat of Absorption Btu/hr	COP @ design	Fluid Pressure Drop ft H <sub>2</sub> O	
Entering °F	Leaving °F	Entering Dry Bulb °F	Leaving Dry Bulb °F					
40.0	34.3	70.0	93.6	43818	31571	3.6	9.71	

**Electrical**

Unit Voltage	Minimum Voltage	Total Unit Full Load Current	Total Unit MCA
460/60/3	416 V	8.0 A	9.6 A
Compressor RLA	Compressor LRA	Motor FLA	Maximum Recommended Fuse Size / HACR Breaker Size
6.2 A	41.0 A	1.8 A	15 A

\*Short-Circuit Current = 5 kA rms symmetrical, 600 V maximum

**Physical**

Unit						
Length	Height	Width	Weight		Connection	
			Shipping	Operating	Water	Condensate
53.9 in	21.0 in	23.9 in	331 lb	296 lb	1.00 in	0.75 in

Fan	
Motor Type	Motor Horsepower
PSC - Standard Static	0.50 hp

Unit Options	
<b>Controls</b>	
Unit Control:	Microtech III
Control Transformer:	Standard 50 VA Transformer
Thermostat / Sensor Control:	Thermostat Control
<b>Unit Airflow Configuration</b>	
Return Air Location:	Right Hand
Discharge Air Location:	End

Construction Options	
<b>Drain Pan Material</b>	
Primary:	Stainless Steel
<b>Filters</b>	
Filter Rack Type:	Standard 1-inch 2-Sided
Filter Type:	1-inch Throwaway
(Quantity) Nominal Filter Dimensions:	(2) 16 in x 20 in x 1 in
<b>Insulation</b>	
Compressor Compartment:	1/2 inch Fiberglass, Skin-faced
Air Compartment:	1/2 inch Fiberglass, Skin-faced
<b>Miscellaneous</b>	
Coil Treatment:	None

Warranty	
Unit Warranty:	4 Yr Refrigerant Circuit Only Extended Parts Warranty, 1st Yr Labor Allowance

AHRI Certification	
	<p>All equipment is rated and certified in accordance with AHRI / ISO 13256-1 and tested, investigated, and determined to comply with the requirements of the standards for Heating and Cooling Equipment UL 60335-2-40 Version 2 for the United States and CAN/CSA-C22.2 NO. 60335-2-40 Version 2 for Canada.</p>

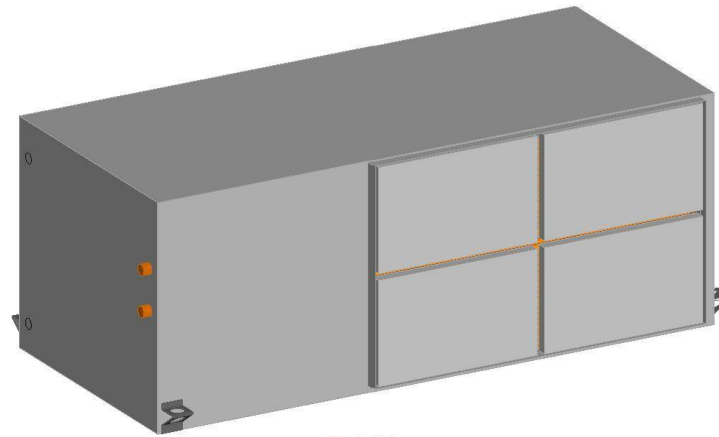

Model View

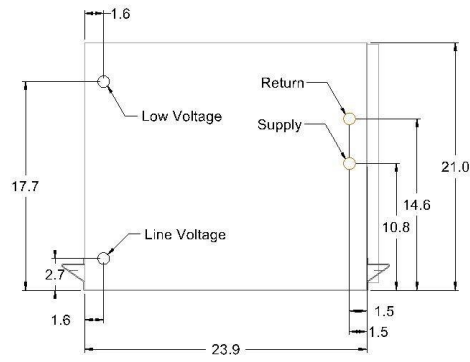

End

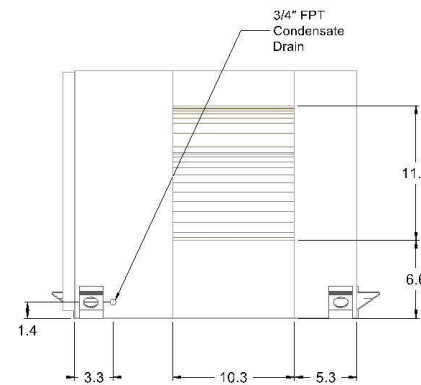

Front

<b>Product Drawing</b>		Unit Tag: HP-Principal			Sales Office: Mechanical Sales, Inc.			 13600 Industrial Park Blvd. Minneapolis, MN 55441 www.DaikinApplied.com Software Version: 12.00
Product:		Project Name: Valparaiso Elementary			Sales Engineer: Brad McKewon			
Model: WGCH048		Feb. 08, 2024	Ver/Rev:	Sheet: 1 of 1	Scale: NTS	Tolerance: +/- 0.25"	Dwg Units: (in)	

No change to this drawing may be made unless approved in writing by Daikin Applied. Purchaser must determine that the equipment is fit and sufficient for the job specifications.

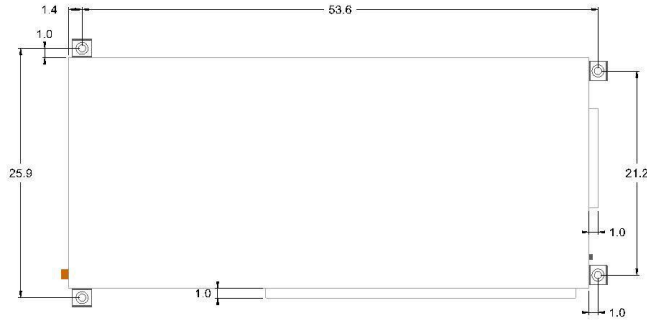

Top View



Bottom View

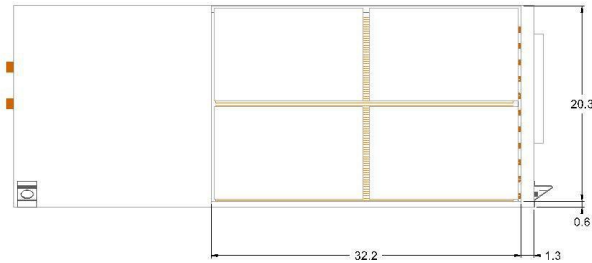

Left Side

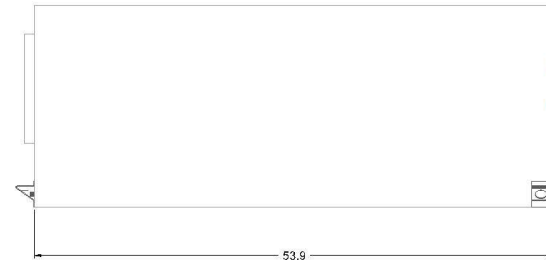

Right Side

**Product Drawing**

Product:

Model: WGCH048

Unit Tag: HP-Principal

Project Name: Valparaiso Elementary

Feb. 08, 2024

Ver/Rev:

Sheet: 1 of 1

Sales Office: Mechanical Sales, Inc.

Sales Engineer: Brad McKewon

Scale: NTS

Tolerance: +/- 0.25"

Dwg Units: (in)



13600 Industrial Park Blvd. Minneapolis, MN 55441  
 www.DaikinApplied.com Software Version: 12.00

No change to this drawing may be made unless approved in writing by Daikin Applied. Purchaser must determine that the equipment is fit and sufficient for the job specifications.

Job Information		Technical Data Sheet
Job Name	Valparaiso Elementary School	
Date	2/8/2024	
Submitted By	Brad McKewon	
Software Version	12.00	
Unit Tag	HP-4	



Unit Overview									
Model Number	Voltage V/Hz/Phase	Airflow CFM	Fluid Flow gpm	Cooling Capacity Btu/hr	Cooling Efficiency EER@AHRI	Cooling Efficiency EER@Design	Heating Capacity Btu/hr	Heating Efficiency COP@AHRI	Heating Efficiency COP@Design
WGCH060	460/60/3	2199	15.00	58434	14.9	12.0	57899	3.2	3.5

Unit			
Model Number:	WGCH060		
Unit Type:	SmartSource Compact - Single Stage		
Approval:	ETL, CETL, AHRI		
Configuration	Refrigerant Type	Refrigerant Weight	Loop Temperature Range
Horizontal	R-410A	60.0 oz	Ground Loop (Geothermal)

Unit Performance				
Air & Fluid Flow				
Airflow	Total External Static Pressure	Fluid Flow	Fluid Type	Altitude
2199 CFM	0.30 inH <sub>2</sub> O	15.00 gpm	Water	0 ft

Cooling Performance										
Fluid Temperature		Air Temperature				Capacity		Heat of Rejection Btu/hr	EER @ design	Fluid Pressure Drop ft H <sub>2</sub> O
Entering °F	Leaving °F	Entering		Leaving		Total Btu/hr	Sensible Btu/hr			
		Dry Bulb °F	Wet Bulb °F	Dry Bulb °F	Wet Bulb °F					
85.0	95.0	78.0	65.0	59.3	56.0	58434	44554	75051	12.0	15.70

Heating Performance							
Fluid Temperature		Air Temperature		Capacity Total Btu/hr	Heat of Absorption Btu/hr	COP @ design	Fluid Pressure Drop ft H <sub>2</sub> O
Entering °F	Leaving °F	Entering Dry Bulb °F	Leaving Dry Bulb °F				
40.0	34.5	70.0	94.2	57899	41123	3.5	17.35

Electrical			
Unit Voltage	Minimum Voltage	Total Unit Full Load Current	Total Unit MCA
460/60/3	416 V	10.2 A	12.2 A
Compressor RLA	Compressor LRA	Motor FLA	Maximum Recommended Fuse Size / HACR Breaker Size
7.8 A	52.0 A	2.4 A	15 A

\*Short-Circuit Current = 5 kA rms symmetrical, 600 V maximum

Physical						
Unit						
Length	Height	Width	Weight		Connection	
			Shipping	Operating	Water	Condensate
53.9 in	21.0 in	23.9 in	345 lb	313 lb	1.00 in	0.75 in
Fan						
Motor Type				Motor Horsepower		
PSC - Standard Static				0.75 hp		

Unit Options	
Controls	
Unit Control:	Microtech III
Control Transformer:	Standard 50 VA Transformer
Thermostat / Sensor Control:	Thermostat Control
Unit Airflow Configuration	
Return Air Location:	Right Hand
Discharge Air Location:	End

Construction Options	
Drain Pan Material	
Primary:	Stainless Steel
Filters	
Filter Rack Type:	Standard 1-inch 2-Sided
Filter Type:	1-inch Throwaway
(Quantity) Nominal Filter Dimensions:	(2) 16 in x 20 in x 1 in
Insulation	
Compressor Compartment:	1/2 inch Fiberglass, Skin-faced
Air Compartment:	1/2 inch Fiberglass, Skin-faced
Miscellaneous	
Coil Treatment:	None

Warranty	
Unit Warranty:	4 Yr Refrigerant Circuit Only Extended Parts Warranty, 1st Yr Labor Allowance

AHRI Certification	
	<p>All equipment is rated and certified in accordance with AHRI / ISO 13256-1 and tested, investigated, and determined to comply with the requirements of the standards for Heating and Cooling Equipment UL 60335-2-40 Version 2 for the United States and CAN/CSA-C22.2 NO. 60335-2-40 Version 2 for Canada.</p>

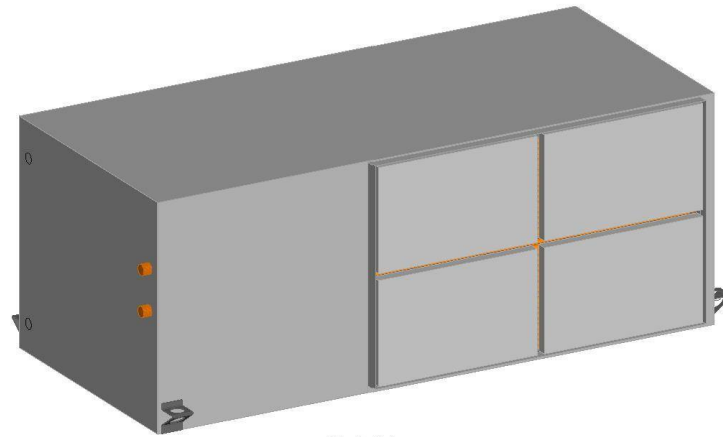

Model View

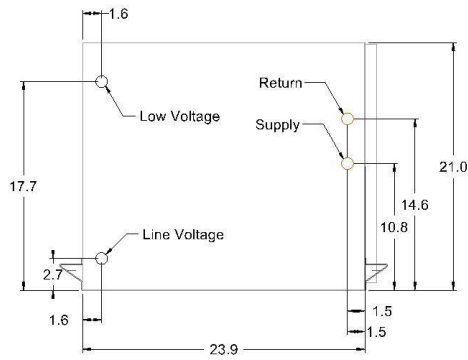

End

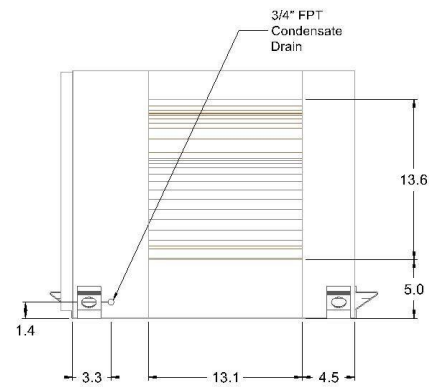

Front

**Product Drawing**

Unit Tag: HP-4

Sales Office: Mechanical Sales, Inc.

Product:

Project Name: Valparaiso Elementary

Sales Engineer: Brad McKewon

Model: WGCH060

Feb. 08, 2024

Ver/Rev:

Sheet: 1 of 1

Scale: NTS

Tolerance: +/- 0.25"

Dwg Units: (in)



13600 Industrial Park Blvd. Minneapolis, MN 55441  
 www.DaikinApplied.com Software Version: 12.00

No change to this drawing may be made unless approved in writing by Daikin Applied. Purchaser must determine that the equipment is fit and sufficient for the job specifications.

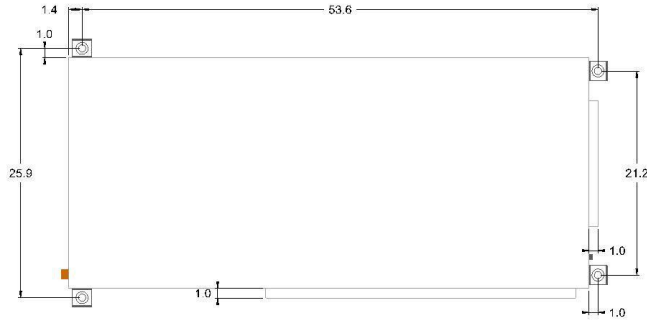

Top View

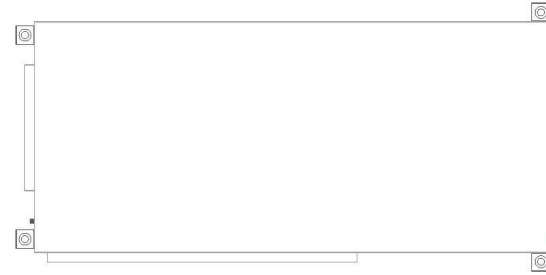

Bottom View

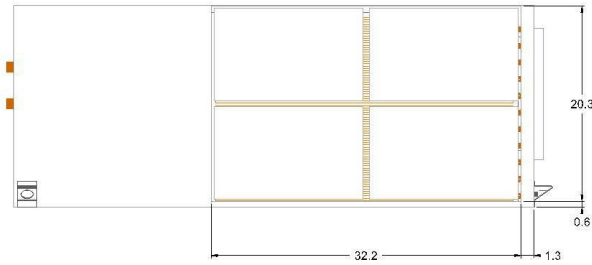

Left Side

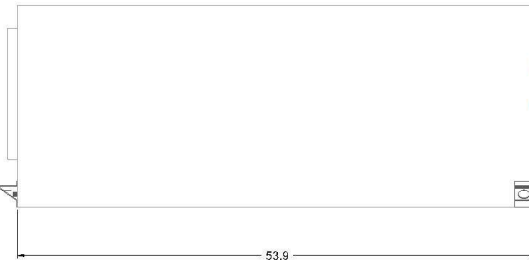

Right Side

<b>Product Drawing</b>		Unit Tag: HP-4			Sales Office: Mechanical Sales, Inc.			 13600 Industrial Park Blvd. Minneapolis, MN 55441 www.DaikinApplied.com Software Version: 12.00
Product:		Project Name: Valparaiso Elementary			Sales Engineer: Brad McKewon			
Model: WGCH060		Feb. 08, 2024	Ver/Rev:	Sheet: 1 of 1	Scale: NTS	Tolerance: +/- 0.25"	Dwg Units: (in)	

No change to this drawing may be made unless approved in writing by Daikin Applied. Purchaser must determine that the equipment is fit and sufficient for the job specifications.

Job Information		Technical Data Sheet
Job Name	Valparaiso Elementary School	
Date	2/8/2024	
Submitted By	Brad McKewon	
Software Version	12.00	
Unit Tag	HP-10	



Unit Overview									
Model Number	Voltage V/Hz/Phase	Airflow CFM	Fluid Flow gpm	Cooling Capacity Btu/hr	Cooling Efficiency EER@AHRI	Cooling Efficiency EER@Design	Heating Capacity Btu/hr	Heating Efficiency COP@AHRI	Heating Efficiency COP@Design
WGCH060	460/60/3	2199	15.00	58434	14.9	12.0	57899	3.2	3.5

Unit			
Model Number:	WGCH060		
Unit Type:	SmartSource Compact - Single Stage		
Approval:	ETL, CETL, AHRI		
Configuration	Refrigerant Type	Refrigerant Weight	Loop Temperature Range
Horizontal	R-410A	60.0 oz	Ground Loop (Geothermal)

**Unit Performance**

Air & Fluid Flow				
Airflow	Total External Static Pressure	Fluid Flow	Fluid Type	Altitude
2199 CFM	0.30 inH <sub>2</sub> O	15.00 gpm	Water	0 ft

Cooling Performance										
Fluid Temperature		Air Temperature				Capacity		Heat of Rejection Btu/hr	EER @ design	Fluid Pressure Drop ft H <sub>2</sub> O
Entering °F	Leaving °F	Entering		Leaving		Total Btu/hr	Sensible Btu/hr			
		Dry Bulb °F	Wet Bulb °F	Dry Bulb °F	Wet Bulb °F					
85.0	95.0	78.0	65.0	59.3	56.0	58434	44554	75051	12.0	15.70

Heating Performance								
Fluid Temperature		Air Temperature		Capacity Total Btu/hr	Heat of Absorption Btu/hr	COP @ design	Fluid Pressure Drop ft H <sub>2</sub> O	
Entering °F	Leaving °F	Entering Dry Bulb °F	Leaving Dry Bulb °F					
40.0	34.5	70.0	94.2	57899	41123	3.5	17.35	

**Electrical**

Unit Voltage	Minimum Voltage	Total Unit Full Load Current	Total Unit MCA
460/60/3	416 V	10.2 A	12.2 A
Compressor RLA	Compressor LRA	Motor FLA	Maximum Recommended Fuse Size / HACR Breaker Size
7.8 A	52.0 A	2.4 A	15 A

\*Short-Circuit Current = 5 kA rms symmetrical, 600 V maximum

**Physical**

Unit						
Length	Height	Width	Weight		Connection	
			Shipping	Operating	Water	Condensate
53.9 in	21.0 in	23.9 in	345 lb	313 lb	1.00 in	0.75 in

Fan	
Motor Type	Motor Horsepower
PSC - Standard Static	0.75 hp

Unit Options	
<b>Controls</b>	
Unit Control:	Microtech III
Control Transformer:	Standard 50 VA Transformer
Thermostat / Sensor Control:	Thermostat Control
<b>Unit Airflow Configuration</b>	
Return Air Location:	Left Hand
Discharge Air Location:	Straight

Construction Options	
<b>Drain Pan Material</b>	
Primary:	Stainless Steel
<b>Filters</b>	
Filter Rack Type:	Standard 1-inch 2-Sided
Filter Type:	1-inch Throwaway
(Quantity) Nominal Filter Dimensions:	(2) 16 in x 20 in x 1 in
<b>Insulation</b>	
Compressor Compartment:	1/2 inch Fiberglass, Skin-faced
Air Compartment:	1/2 inch Fiberglass, Skin-faced
<b>Miscellaneous</b>	
Coil Treatment:	None

Warranty	
Unit Warranty:	4 Yr Refrigerant Circuit Only Extended Parts Warranty, 1st Yr Labor Allowance

AHRI Certification	
	<p>All equipment is rated and certified in accordance with AHRI / ISO 13256-1 and tested, investigated, and determined to comply with the requirements of the standards for Heating and Cooling Equipment UL 60335-2-40 Version 2 for the United States and CAN/CSA-C22.2 NO. 60335-2-40 Version 2 for Canada.</p>

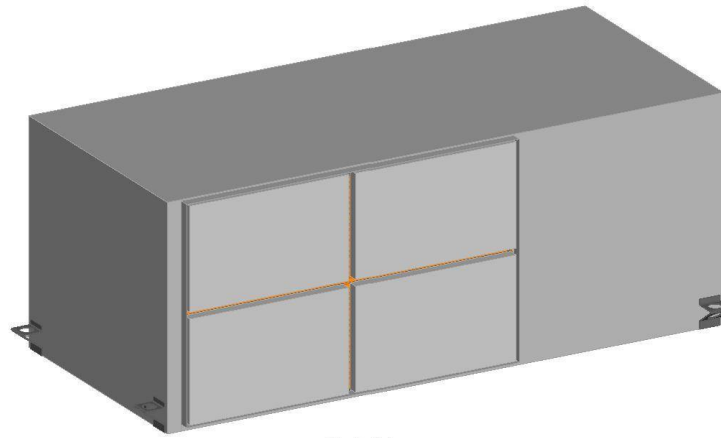

Model View

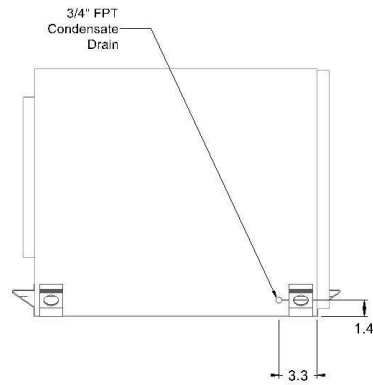

End

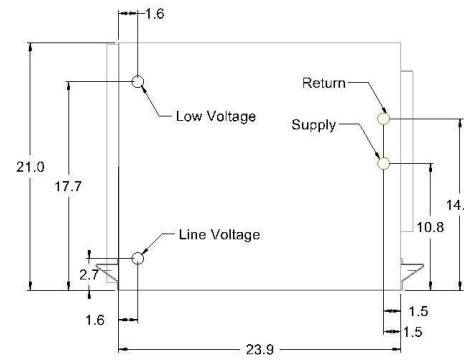

Front

**Product Drawing**

Unit Tag: HP-10

Sales Office: Mechanical Sales, Inc.

Product:

Project Name: Valparaiso Elementary

Sales Engineer: Brad McKewon

Model: WGCH060

Feb. 08, 2024

Ver/Rev:

Sheet: 1 of 1

Scale: NTS

Tolerance: +/- 0.25"

Dwg Units: (in)



13600 Industrial Park Blvd. Minneapolis, MN 55441  
 www.DaikinApplied.com Software Version: 12.00

No change to this drawing may be made unless approved in writing by Daikin Applied. Purchaser must determine that the equipment is fit and sufficient for the job specifications.

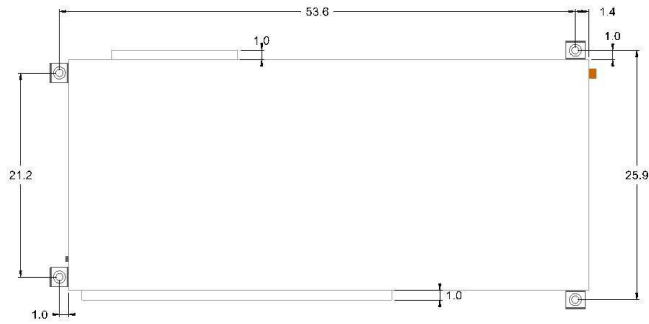

Top View

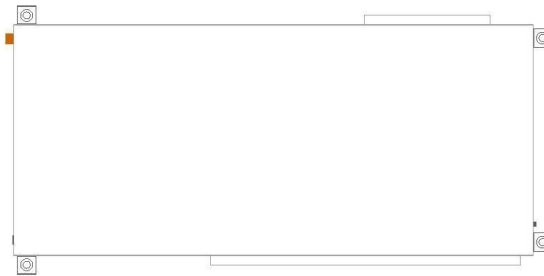

Bottom View

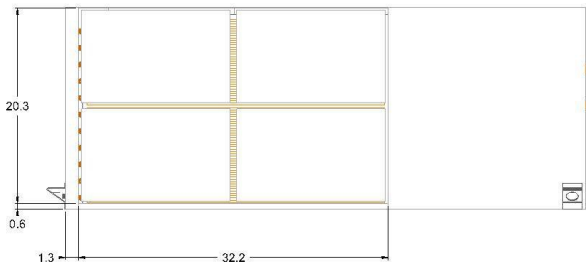

Left Side

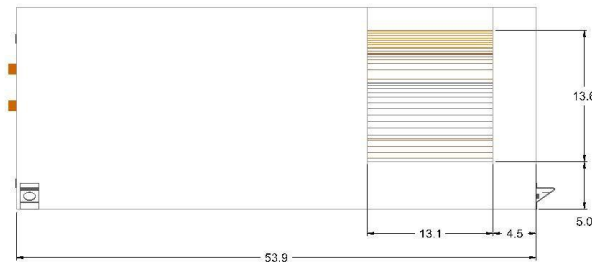

Right Side

**Product Drawing**

Product:

Model: WGCH060

Unit Tag: HP-10

Project Name: Valparaiso Elementary

Feb. 08, 2024

Ver/Rev:

Sheet: 1 of 1

Sales Office: Mechanical Sales, Inc.

Sales Engineer: Brad McKewon

Scale: NTS

Tolerance: +/- 0.25"

Dwg Units: (in)



13600 Industrial Park Blvd. Minneapolis, MN 55441  
 www.DaikinApplied.com Software Version: 12.00

No change to this drawing may be made unless approved in writing by Daikin Applied. Purchaser must determine that the equipment is fit and sufficient for the job specifications.

Job Information		Technical Data Sheet
Job Name	Valparaiso Elementary School	
Date	2/8/2024	
Submitted By	Brad McKewon	
Software Version	12.00	
Unit Tag	HP-16	



Unit Overview									
Model Number	Voltage V/Hz/Phase	Airflow CFM	Fluid Flow gpm	Cooling Capacity Btu/hr	Cooling Efficiency EER@AHRI	Cooling Efficiency EER@Design	Heating Capacity Btu/hr	Heating Efficiency COP@AHRI	Heating Efficiency COP@Design
WGCH060	460/60/3	2199	15.00	58434	14.9	12.0	57899	3.2	3.5

Unit			
Model Number:	WGCH060		
Unit Type:	SmartSource Compact - Single Stage		
Approval:	ETL, CETL, AHRI		
Configuration	Refrigerant Type	Refrigerant Weight	Loop Temperature Range
Horizontal	R-410A	60.0 oz	Ground Loop (Geothermal)

**Unit Performance**

Air & Fluid Flow				
Airflow	Total External Static Pressure	Fluid Flow	Fluid Type	Altitude
2199 CFM	0.30 inH <sub>2</sub> O	15.00 gpm	Water	0 ft

Cooling Performance										
Fluid Temperature		Air Temperature				Capacity		Heat of Rejection Btu/hr	EER @ design	Fluid Pressure Drop ft H <sub>2</sub> O
Entering °F	Leaving °F	Entering		Leaving		Total Btu/hr	Sensible Btu/hr			
		Dry Bulb °F	Wet Bulb °F	Dry Bulb °F	Wet Bulb °F					
85.0	95.0	78.0	65.0	59.3	56.0	58434	44554	75051	12.0	15.70

Heating Performance								
Fluid Temperature		Air Temperature		Capacity Total Btu/hr	Heat of Absorption Btu/hr	COP @ design	Fluid Pressure Drop ft H <sub>2</sub> O	
Entering °F	Leaving °F	Entering Dry Bulb °F	Leaving Dry Bulb °F					
40.0	34.5	70.0	94.2	57899	41123	3.5	17.35	

**Electrical**

Unit Voltage	Minimum Voltage	Total Unit Full Load Current	Total Unit MCA
460/60/3	416 V	10.2 A	12.2 A
Compressor RLA	Compressor LRA	Motor FLA	Maximum Recommended Fuse Size / HACR Breaker Size
7.8 A	52.0 A	2.4 A	15 A

\*Short-Circuit Current = 5 kA rms symmetrical, 600 V maximum

**Physical**

Unit						
Length	Height	Width	Weight		Connection	
			Shipping	Operating	Water	Condensate
53.9 in	21.0 in	23.9 in	345 lb	313 lb	1.00 in	0.75 in

Fan	
Motor Type	Motor Horsepower
PSC - Standard Static	0.75 hp

Unit Options	
<b>Controls</b>	
Unit Control:	Microtech III
Control Transformer:	Standard 50 VA Transformer
Thermostat / Sensor Control:	Thermostat Control
<b>Unit Airflow Configuration</b>	
Return Air Location:	Left Hand
Discharge Air Location:	End

Construction Options	
<b>Drain Pan Material</b>	
Primary:	Stainless Steel
<b>Filters</b>	
Filter Rack Type:	Standard 1-inch 2-Sided
Filter Type:	1-inch Throwaway
(Quantity) Nominal Filter Dimensions:	(2) 16 in x 20 in x 1 in
<b>Insulation</b>	
Compressor Compartment:	1/2 inch Fiberglass, Skin-faced
Air Compartment:	1/2 inch Fiberglass, Skin-faced
<b>Miscellaneous</b>	
Coil Treatment:	None

Warranty	
Unit Warranty:	4 Yr Refrigerant Circuit Only Extended Parts Warranty, 1st Yr Labor Allowance

AHRI Certification	
	All equipment is rated and certified in accordance with AHRI / ISO 13256-1 and tested, investigated, and determined to comply with the requirements of the standards for Heating and Cooling Equipment UL 60335-2-40 Version 2 for the United States and CAN/CSA-C22.2 NO. 60335-2-40 Version 2 for Canada.

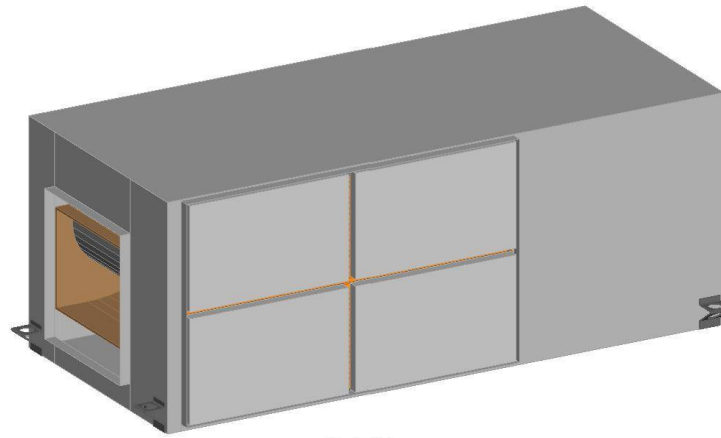

Model View

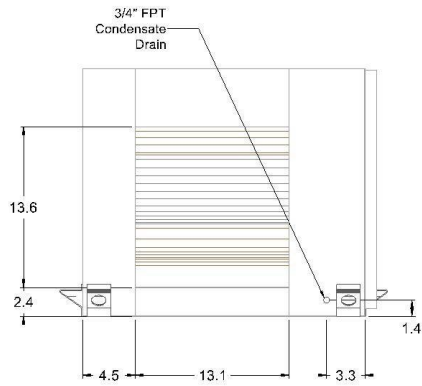

End

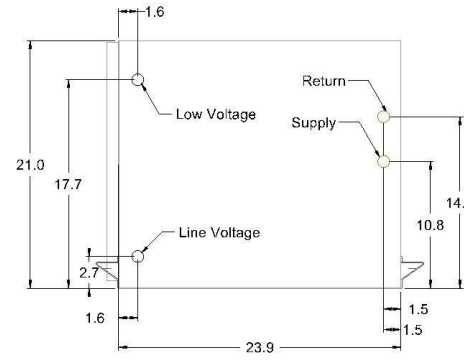

Front

**Product Drawing**

Unit Tag: HP-16

Sales Office: Mechanical Sales, Inc.

Product:

Project Name: Valparaiso Elementary

Sales Engineer: Brad McKewon

Model: WGCH060

Feb. 08, 2024

Ver/Rev:

Sheet: 1 of 1

Scale: NTS

Tolerance: +/- 0.25"

Dwg Units: (in)



13600 Industrial Park Blvd. Minneapolis, MN 55441  
 www.DaikinApplied.com Software Version: 12.00

No change to this drawing may be made unless approved in writing by Daikin Applied. Purchaser must determine that the equipment is fit and sufficient for the job specifications.

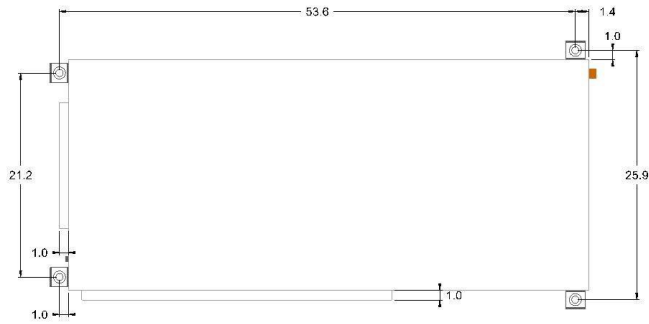

Top View



Bottom View

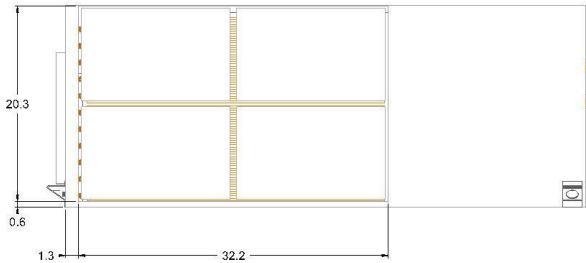

Left Side

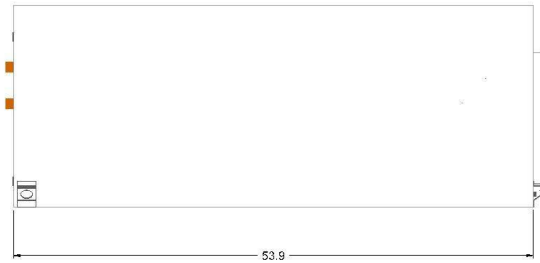

Right Side

**Product Drawing**

Product:

Model: WGCH060

Unit Tag: HP-16

Project Name: Valparaiso Elementary

Feb. 08, 2024

Ver/Rev:

Sheet: 1 of 1

Sales Office: Mechanical Sales, Inc.

Sales Engineer: Brad McKewon

Scale: NTS

Tolerance: +/- 0.25"

Dwg Units: (in)



13600 Industrial Park Blvd. Minneapolis, MN 55441  
 www.DaikinApplied.com Software Version: 12.00

No change to this drawing may be made unless approved in writing by Daikin Applied. Purchaser must determine that the equipment is fit and sufficient for the job specifications.

Job Information		Technical Data Sheet
Job Name	Valparaiso Elementary School	
Date	2/8/2024	
Submitted By	Brad McKewon	
Software Version	12.00	
Unit Tag	HP-136N	



Unit Overview									
Model Number	Voltage V/Hz/Phase	Airflow CFM	Fluid Flow gpm	Cooling Capacity Btu/hr	Cooling Efficiency EER@AHRI	Cooling Efficiency EER@Design	Heating Capacity Btu/hr	Heating Efficiency COP@AHRI	Heating Efficiency COP@Design
WGCH060	460/60/3	2199	15.00	58434	14.9	12.0	57899	3.2	3.5

Unit			
Model Number:	WGCH060		
Unit Type:	SmartSource Compact - Single Stage		
Approval:	ETL, CETL, AHRI		
Configuration	Refrigerant Type	Refrigerant Weight	Loop Temperature Range
Horizontal	R-410A	60.0 oz	Ground Loop (Geothermal)

**Unit Performance**

Air & Fluid Flow				
Airflow	Total External Static Pressure	Fluid Flow	Fluid Type	Altitude
2199 CFM	0.30 inH <sub>2</sub> O	15.00 gpm	Water	0 ft

Cooling Performance										
Fluid Temperature		Air Temperature				Capacity		Heat of Rejection Btu/hr	EER @ design	Fluid Pressure Drop ft H <sub>2</sub> O
Entering °F	Leaving °F	Entering		Leaving		Total Btu/hr	Sensible Btu/hr			
		Dry Bulb °F	Wet Bulb °F	Dry Bulb °F	Wet Bulb °F					
85.0	95.0	78.0	65.0	59.3	56.0	58434	44554	75051	12.0	15.70

Heating Performance							
Fluid Temperature		Air Temperature		Capacity Total Btu/hr	Heat of Absorption Btu/hr	COP @ design	Fluid Pressure Drop ft H <sub>2</sub> O
Entering °F	Leaving °F	Entering Dry Bulb °F	Leaving Dry Bulb °F				
40.0	34.5	70.0	94.2	57899	41123	3.5	17.35

**Electrical**

Unit Voltage	Minimum Voltage	Total Unit Full Load Current	Total Unit MCA
460/60/3	416 V	10.2 A	12.2 A
Compressor RLA	Compressor LRA	Motor FLA	Maximum Recommended Fuse Size / HACR Breaker Size
7.8 A	52.0 A	2.4 A	15 A

\*Short-Circuit Current = 5 kA rms symmetrical, 600 V maximum

**Physical**

Unit						
Length	Height	Width	Weight		Connection	
			Shipping	Operating	Water	Condensate
53.9 in	21.0 in	23.9 in	345 lb	313 lb	1.00 in	0.75 in

Fan	
Motor Type	Motor Horsepower
PSC - Standard Static	0.75 hp

Unit Options	
<b>Controls</b>	
Unit Control:	Microtech III
Control Transformer:	Standard 50 VA Transformer
Thermostat / Sensor Control:	Thermostat Control
<b>Unit Airflow Configuration</b>	
Return Air Location:	Right Hand
Discharge Air Location:	End

Construction Options	
<b>Drain Pan Material</b>	
Primary:	Stainless Steel
<b>Filters</b>	
Filter Rack Type:	Standard 1-inch 2-Sided
Filter Type:	1-inch Throwaway
(Quantity) Nominal Filter Dimensions:	(2) 16 in x 20 in x 1 in
<b>Insulation</b>	
Compressor Compartment:	1/2 inch Fiberglass, Skin-faced
Air Compartment:	1/2 inch Fiberglass, Skin-faced
<b>Miscellaneous</b>	
Coil Treatment:	None

Warranty	
Unit Warranty:	4 Yr Refrigerant Circuit Only Extended Parts Warranty, 1st Yr Labor Allowance

AHRI Certification	
	<p>All equipment is rated and certified in accordance with AHRI / ISO 13256-1 and tested, investigated, and determined to comply with the requirements of the standards for Heating and Cooling Equipment UL 60335-2-40 Version 2 for the United States and CAN/CSA-C22.2 NO. 60335-2-40 Version 2 for Canada.</p>

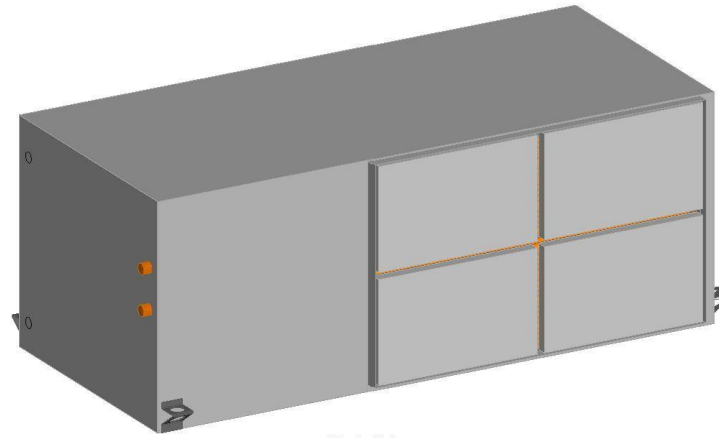

Model View

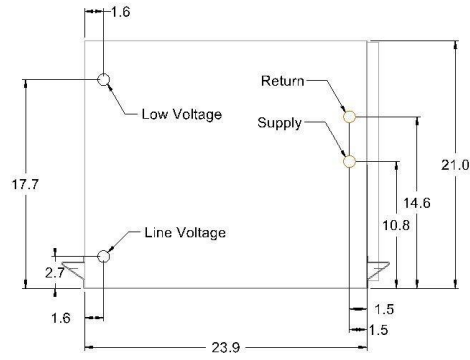

End

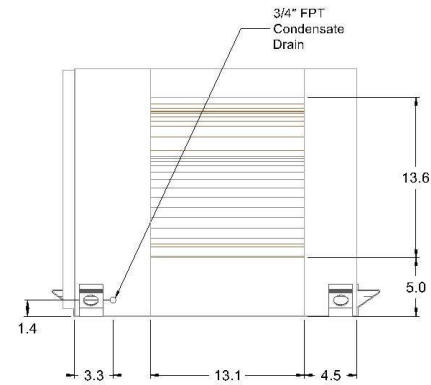

Front

<b>Product Drawing</b>		Unit Tag: HP-136N			Sales Office: Mechanical Sales, Inc.			 13600 Industrial Park Blvd. Minneapolis, MN 55441 www.DaikinApplied.com Software Version: 12.00
Product:		Project Name: Valparaiso Elementary			Sales Engineer: Brad McKewon			
Model: WGCH060		Feb. 08, 2024	Ver/Rev:	Sheet: 1 of 1	Scale: NTS	Tolerance: +/- 0.25"	Dwg Units: (in)	

No change to this drawing may be made unless approved in writing by Daikin Applied. Purchaser must determine that the equipment is fit and sufficient for the job specifications.

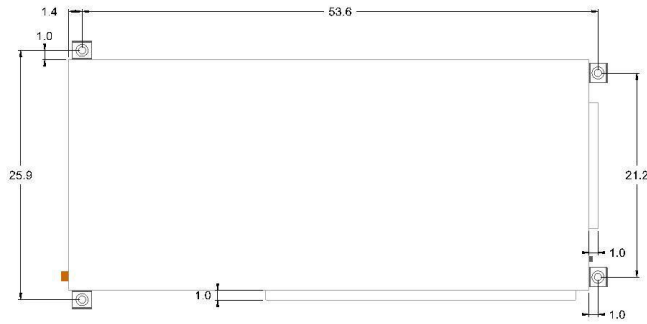

Top View



Bottom View

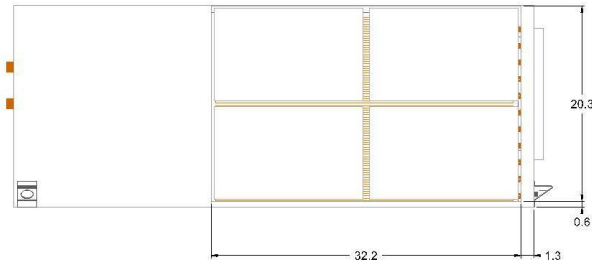

Left Side

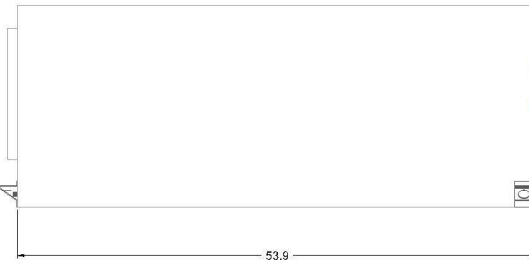

Right Side

**Product Drawing**

Product:

Model: WGCH060

Unit Tag: HP-136N

Project Name: Valparaiso Elementary

Feb. 08, 2024

Ver/Rev:

Sheet: 1 of 1

Sales Office: Mechanical Sales, Inc.

Sales Engineer: Brad McKewon

Scale: NTS

Tolerance: +/- 0.25"

Dwg Units: (in)



13600 Industrial Park Blvd. Minneapolis, MN 55441  
 www.DaikinApplied.com Software Version: 12.00

No change to this drawing may be made unless approved in writing by Daikin Applied. Purchaser must determine that the equipment is fit and sufficient for the job specifications.

Job Information		Technical Data Sheet	
Job Name	Valparaiso Elementary School		
Date	2/8/2024		
Submitted By	Brad McKewon		
Software Version	12.00		
Unit Tag	HP-Kindergarden		



**Unit Overview**

Model Number	Voltage V/Hz/Phase	Airflow CFM	Fluid Flow gpm	Cooling Capacity Btu/hr	Cooling Efficiency EER@AHRI	Cooling Efficiency EER@Design	Heating Capacity Btu/hr	Heating Efficiency COP@AHRI	Heating Efficiency COP@Design
WGCH060	460/60/3	2199	15.00	58434	14.9	12.0	57899	3.2	3.5

**Unit**

Model Number:	WGCH060		
Unit Type:	SmartSource Compact - Single Stage		
Approval:	ETL, CETL, AHRI		
Configuration	Refrigerant Type	Refrigerant Weight	Loop Temperature Range
Horizontal	R-410A	60.0 oz	Ground Loop (Geothermal)

**Unit Performance**

Air & Fluid Flow				
Airflow	Total External Static Pressure	Fluid Flow	Fluid Type	Altitude
2199 CFM	0.30 inH <sub>2</sub> O	15.00 gpm	Water	0 ft

Cooling Performance										
Fluid Temperature		Air Temperature				Capacity		Heat of Rejection Btu/hr	EER @ design	Fluid Pressure Drop ft H <sub>2</sub> O
Entering °F	Leaving °F	Entering		Leaving		Total Btu/hr	Sensible Btu/hr			
		Dry Bulb °F	Wet Bulb °F	Dry Bulb °F	Wet Bulb °F					
85.0	95.0	78.0	65.0	59.3	56.0	58434	44554	75051	12.0	15.70

Heating Performance								
Fluid Temperature		Air Temperature		Capacity Total Btu/hr	Heat of Absorption Btu/hr	COP @ design	Fluid Pressure Drop ft H <sub>2</sub> O	
Entering °F	Leaving °F	Entering Dry Bulb °F	Leaving Dry Bulb °F					
40.0	34.5	70.0	94.2	57899	41123	3.5	17.35	

**Electrical**

Unit Voltage	Minimum Voltage	Total Unit Full Load Current	Total Unit MCA
460/60/3	416 V	10.2 A	12.2 A
Compressor RLA	Compressor LRA	Motor FLA	Maximum Recommended Fuse Size / HACR Breaker Size
7.8 A	52.0 A	2.4 A	15 A

\*Short-Circuit Current = 5 kA rms symmetrical, 600 V maximum

**Physical**

Unit						
Length	Height	Width	Weight		Connection	
			Shipping	Operating	Water	Condensate
53.9 in	21.0 in	23.9 in	345 lb	313 lb	1.00 in	0.75 in

Fan	
Motor Type	Motor Horsepower
PSC - Standard Static	0.75 hp

Unit Options	
Controls	
Unit Control:	Microtech III
Control Transformer:	Standard 50 VA Transformer
Thermostat / Sensor Control:	Thermostat Control
Unit Airflow Configuration	
Return Air Location:	Right Hand
Discharge Air Location:	End

Construction Options	
Drain Pan Material	
Primary:	Stainless Steel
Filters	
Filter Rack Type:	Standard 1-inch 2-Sided
Filter Type:	1-inch Throwaway
(Quantity) Nominal Filter Dimensions:	(2) 16 in x 20 in x 1 in
Insulation	
Compressor Compartment:	1/2 inch Fiberglass, Skin-faced
Air Compartment:	1/2 inch Fiberglass, Skin-faced
Miscellaneous	
Coil Treatment:	None

Warranty	
Unit Warranty:	4 Yr Refrigerant Circuit Only Extended Parts Warranty, 1st Yr Labor Allowance

AHRI Certification	
	<p>All equipment is rated and certified in accordance with AHRI / ISO 13256-1 and tested, investigated, and determined to comply with the requirements of the standards for Heating and Cooling Equipment UL 60335-2-40 Version 2 for the United States and CAN/CSA-C22.2 NO. 60335-2-40 Version 2 for Canada.</p>

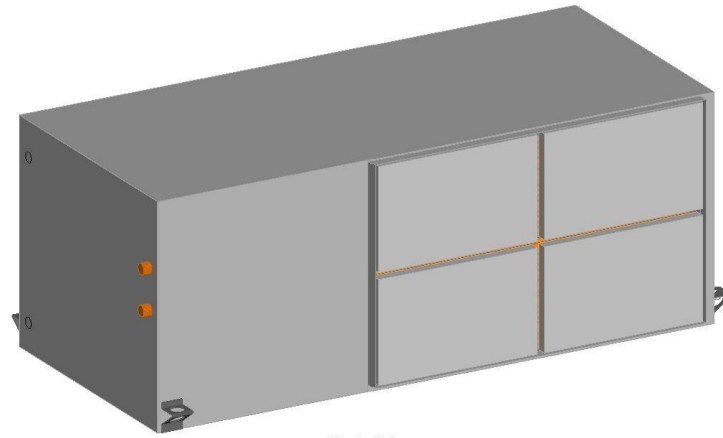

Model View

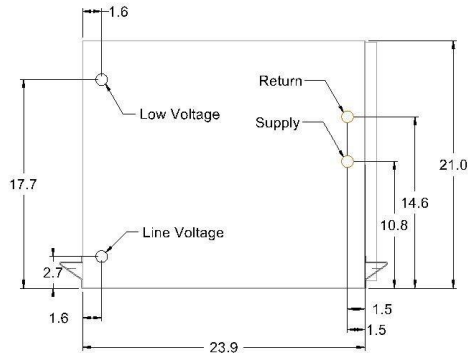

End

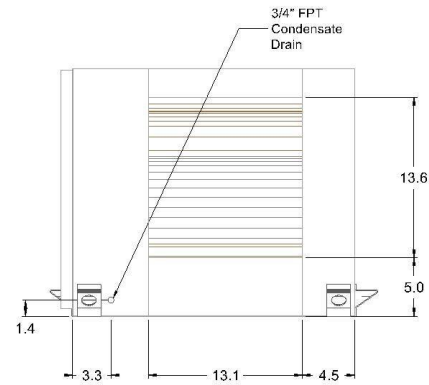

Front

**Product Drawing**

Product:

Model: WGCH060

Unit Tag: HP-Kindergarden

Project Name: Valparaiso Elementary

Feb. 08, 2024

Ver/Rev:

Sheet: 1 of 1

Sales Office: Mechanical Sales, Inc.

Sales Engineer: Brad McKewon

Scale: NTS

Tolerance: +/- 0.25"

Dwg Units: (in)



13600 Industrial Park Blvd. Minneapolis, MN 55441  
 www.DaikinApplied.com Software Version: 12.00

No change to this drawing may be made unless approved in writing by Daikin Applied. Purchaser must determine that the equipment is fit and sufficient for the job specifications.

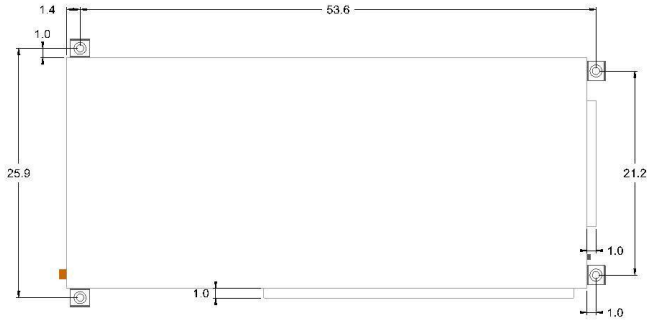

Top View



Bottom View

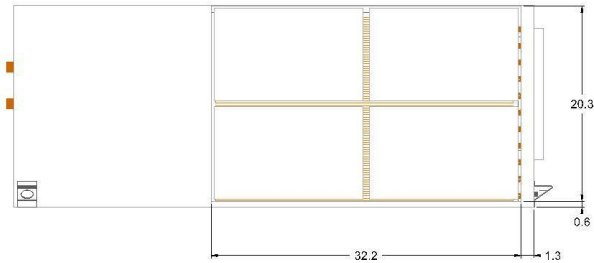

Left Side

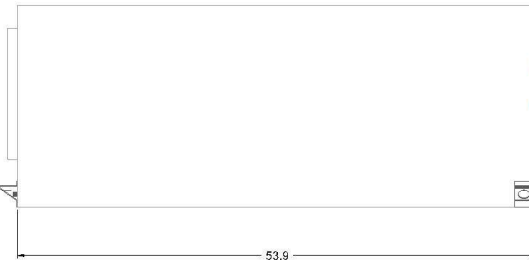

Right Side

**Product Drawing**

Product:

Model: WGCH060

Unit Tag: HP-Kindergarden

Project Name: Valparaiso Elementary

Feb. 08, 2024

Ver/Rev:

Sheet: 1 of 1

Sales Office: Mechanical Sales, Inc.

Sales Engineer: Brad McKewon

Scale: NTS

Tolerance: +/- 0.25"

Dwg Units: (in)



13600 Industrial Park Blvd. Minneapolis, MN 55441  
 www.DaikinApplied.com Software Version: 12.00

No change to this drawing may be made unless approved in writing by Daikin Applied. Purchaser must determine that the equipment is fit and sufficient for the job specifications.



## Condensate Overflow Sensor

### Description

The condensate overflow sensor is standard on all horizontal, vertical, console, and vertical stacked water source heat pumps. Daikin condensate overflow sensors are UL508 approved.

This sensor is an input to the unit controller, the MicroTech® III. A conductor is connected to the top of the drain pan. If condensate reaches the top of the drain pan – the sensor is activated.

### Operation

The controller is designed to sense when condensate water levels in the drain pan become excessively high. When high condensate water levels are detected during cooling or de-humidification mode, the controller will go into condensate overflow warning mode.

- No condensate overflow warnings will occur when the unit is running in heating modes, thus allowing the unit to heat with high condensate water levels
- The fan and pump will operate normally during the condensate overflow fault mode



*Condensate conductor connected to the condensate drain pan.*



## Filter Rack for 1" Disposable Filter

### Description

Standard filter rack is 2-sided, 1" thick with removable door for non-ducted applications. This filter rack accommodates a 1" thick disposable filter.

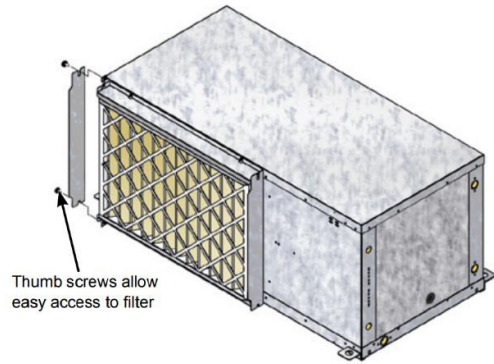

# QUOTATION

**Date:** 2.8.2024  
**Project:** Raymond Central Elementary – Phase I  
**Quote #:** Q24-0204

---

**To:** Raymond Central  
**Attn:** Jared Shanahan

**Bid Date:** 2.8.2024  
**Engineer:** NA  
**Location:** Valparaiso, NE  
**Quoted By:** Brad McKewon

---

**Daikin WSHP's – 2024 Phase I:**

**Water Source Heat Pumps – QTY of 12**

- WGCH019 – 1 Total
- WGCH030 – 2 Total
- WGCH048 – 4 Total
- WGCH060 – 5 Total

**TOTAL NET PRICE – FOB Factory, Full Freight Allowed**

**\$71,500.00**

**NOTE: All Unit Pricing Above Includes:**

- 3 ft. Supply/Return Hose
- 4 Year Refrigerant Circuit Warranty

*This quotation, provided by Mechanical Sales, Inc., is valid for a period of 30 days from the date of issue. The acceptance of this quote implies agreement to adhere to Mechanical Sales, Inc.'s standard terms and conditions as outlined on our official website: [www.mechsales.com/terms-and-conditions](http://www.mechsales.com/terms-and-conditions)*

*By accepting this quotation, you acknowledge and agree to comply with the terms and conditions specified on our website. Any deviations from the standard terms and conditions must be agreed upon in writing and may affect the validity of this quotation.*



# QUOTATION

**Date:** 2.13.2024  
**Project:** Raymond Central Elementary – Phase I  
**Quote #:** Q24-0204

---

**To:** Raymond Central  
**Attn:** Jared Shanahan

**Bid Date:** 2.13.2024  
**Engineer:** NA  
**Location:** Valparaiso, NE  
**Quoted By:** Brad McKewon

---

**Daikin WSHP's – 2024 Phase I:**

**Water Source Heat Pumps – QTY of 12**

- WGCH019 – 1 Total
- WGCH030 – 2 Total
- WGCH048 – 4 Total
- WGCH060 – 5 Total

**TOTAL NET PRICE – FOB Factory, Full Freight Allowed**

**\$73,900.00**

**NOTE: All Unit Pricing Above Includes:**

- Factory Authorized Start-up
- 3 ft. Supply/Return Hose
- 4 Year Refrigerant Circuit Warranty

*This quotation, provided by Mechanical Sales, Inc., is valid for a period of 30 days from the date of issue. The acceptance of this quote implies agreement to adhere to Mechanical Sales, Inc.'s standard terms and conditions as outlined on our official website: [www.mechsales.com/terms-and-conditions](http://www.mechsales.com/terms-and-conditions)*

*By accepting this quotation, you acknowledge and agree to comply with the terms and conditions specified on our website. Any deviations from the standard terms and conditions must be agreed upon in writing and may affect the validity of this quotation.*



New Business

Approval of certificated staff hires/resignations

Discuss, Consider and Take Necessary Action to approve certificated teacher hires

Motion by Lange, second by Burklund to approve new hires: Trace Baasch as PE/Health and Megan Hanson as Middle School Math and PE. RCV 4-0. Motion carried.

Discuss, Consider and Take Necessary action to approve the reassignment of MTSS/MS Coordinator to Assistant Principal/PK Director

Motion by Burklund, second by Lange to approve the reassignment of MSTSS/MS Coordinator to Assistant Principal/Preschool Director. RCV 4-0. Motion carried.

Discuss, Consider and Take Necessary Action to reassign elementary assistant principal to elementary principal

Motion by Benes, second by Breitreutz to reassign the Elementary Assistant Principal to Elementary Principal. RCV 3-1 (Burklund). Motion carried.

Discuss, Consider and Take Necessary Action to Approve Local Substitute Teachers

Motion by Benes, second by Burklund to approve Rhiannon Stoner and Chaylee Tonniges as Local Substitute Teachers. RCV 4-0. Motion carried.

Discuss, Consider and Take Action to approve the Annual Report 2022-2023

Motion by Burklund, second by Lange to approve the 2022-2023 Annual Report as presented. RCV 4-0. Motion carried.



## DISTRICT INFORMATION

### ENROLLMENT

With the continued growth of students at Raymond Central Public Schools, the need for additional space at all levels remains a focus across the district.



**54**  
Teachers



**742**  
K-12 students

### MISSION

The Raymond Central Community is committed to providing a positive, challenging learning environment which prepares each individual student to be a responsible citizen in an ever-changing society.

Raymond Central is a consolidated public school district incorporating the communities of Davey, Raymond, Agnew, Ceresco and Valparaiso.

In 2017, a new preschool program was added to the Jr-Sr High campus. At the same time, the 6th grade program moved into new classrooms adjacent to the preschool. Elementary K-5 centers are located in both Ceresco and Valparaiso. Grades 7-12 attend a traditional Jr-Sr High that meets the varied needs of a wide range of students. The elementary facilities were updated in 2000 and the Jr/Sr High School received updates in 2010 allowing award-winning programs, high quality academic instruction, innovative teaching and one-to-one technology integration.

## RAYMOND CENTRAL PUBLIC SCHOOLS ANNUAL REPORT 2022-2023

Lynn Johnson - Superintendent

### Board of Education (2022-2023)

#### First Semester:

Dr. Harriet Gould - President  
Brad Breitreutz - Vice President  
Cathy Burklund - Secretary  
Matt Blanchard - Treasurer  
Bill Lange - Member  
Derek Matulka - Member

#### Second Semester:

Brad Breitreutz - President  
Cathy Burklund - Vice President  
Bill Lange - Secretary  
Matt Blanchard - Treasurer  
Derek Matulka - Member  
Mary Benes - Member

# HIGHLIGHTS

## School Improvement Goal:

All students will meet or exceed normal growth rate on standardized tests annually.

of Raymond Central students Grades 3-8 maintained or improved their Achievement Level on the NSCAS Growth ELA assessment from Fall to Spring of the 2022-2023 school year

# 92%

# 64%



Teachers with Master's Degree

9th and 10th grade students continued to take the MAP Growth assessment in 2022-2023. 71% of students met or exceeded growth projections on the MAP Reading assessment, while 83% of students met or exceeded growth projections on the MAP Math assessment (Fall or Spring administration).

## Attendance Rate

# 94%

State average: 93%

# ACADEMICS

## Secondary Highlights:

- Professional development focused on implementing engaging instructional practices
- One Raymond Central student qualified as a National Merit Scholar honorable mention
- One student earned a Global Seal of Biliteracy; another earned a Nebraska Seal of Biliteracy
- Three students earned Greater Omaha "Youth Salute" recognition for academics & leadership
- Language Arts and Special Education teachers (6-8) participated in *Science of Reading* training
- Four new dual-enrollment courses added: U.S. History, Statistics, 2-D Art, and 3-D Art

## Elementary Highlights:

- All K-5 teachers participated in *Science of Reading* training
- All elementary classroom and Title I teachers were certified in the Orton-Gillingham approach to teaching foundational skills
- PTO provided interactive family activities, student assemblies and resources for school initiatives
- 100% participation in Parent/Teacher conferences

2022-2023 was the first full school year in which the state's NSCAS Growth assessment was available for the whole school year, after its pilot in 2021-2022. Schools may assess students up to three times per year (Fall, Winter, & Spring). The Spring administration is required as a summative assessment for all schools. The assessment provides a variety of information for schools and teachers in order to make instructional decisions and assess progress. The Spring results are presented below; the percentage of students classified as both "On Track" or "Advanced" for both the district and state are included.

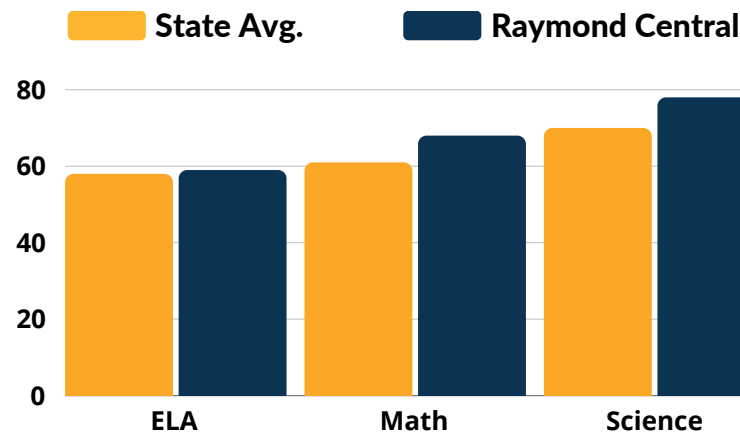

## COLLEGE-GOING RATE



## GRADUATION RATE

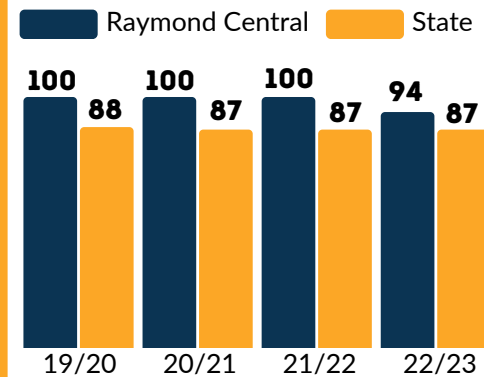

## DUAL CREDIT:

68 Students earned 650 post-secondary credits in 2022-2023

# 650

# HIGHLIGHTS

# 90%

of students grades 7-12 participated in at least one sport, club, or activity

# 41

Number of times the speech team has won the NCC Speech Tournament

# 77

Students participated in FOUR or more activities during the 2022/2023 school year

Fall Sports Participation

# 201

# 160

Winter Sports Participation

Spring Sports Participation

# 103

# 194

Total Fine Arts Participation

# ACTIVITIES

- Speech: Twelve participants qualified for state competition, including one finalist
- FFA: Twenty-eight students participated in state competition, including the state champion parliamentary procedure team, which also qualified for nationals
- Boys Wrestling: Qualified for State Duals and finished in 5th place. Eight individual competitors qualified for state, with one runner-up and one 6th place finisher
- Girls Wrestling: Qualified one competitor for state; finished as state runner-up
- FBLA: Twelve students participated in state competition and qualified five for nationals
- Track: Three individuals qualified for the state track meet
- Cheer: Placed third in the state tumbling competition

### Student Participation by Number of Activities (Grades 7-12)

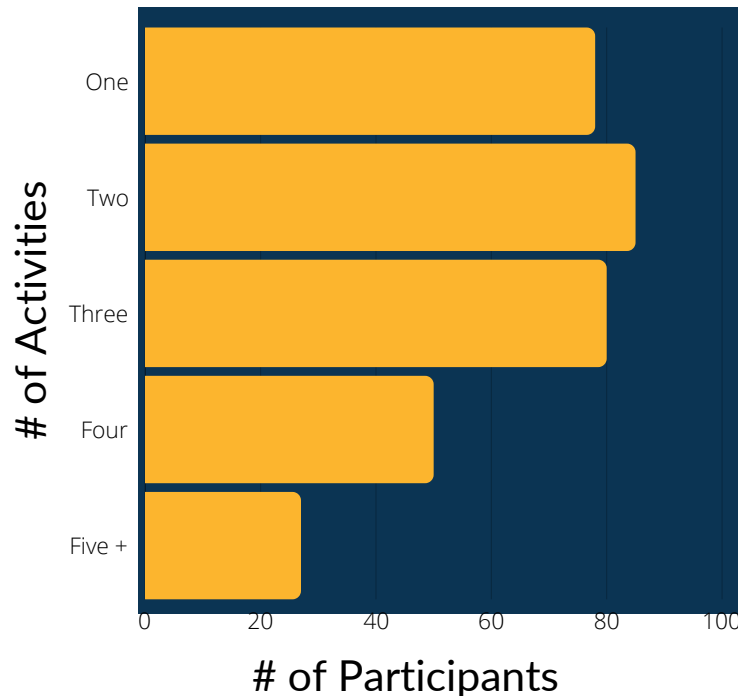

# 44%

of students grades 7-12 participated in at least three activities

# 320

Students participated in at least one activity during the 2022/2023 school year

# HIGHLIGHTS

**↑ 29%**  
Enrollment

**↑ 49%**  
Valuation

\*\*Since 2013-2014\*\*

## State Aid (TEOSA) Since 2017-2018

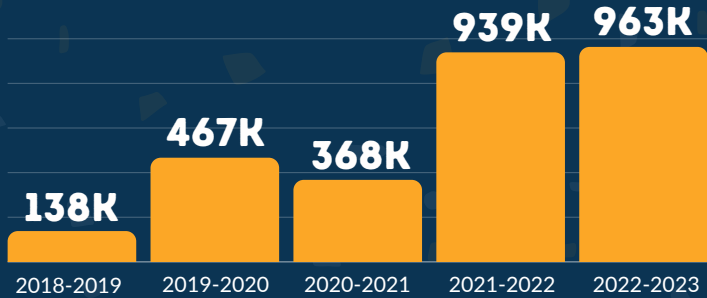

**\$17,044**

Expenditure  
Per Pupil



### Revenue/Funding Sources

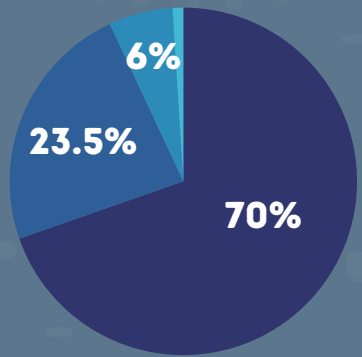

Local State  
Federal County/Other

Based on 2022/2023 Data

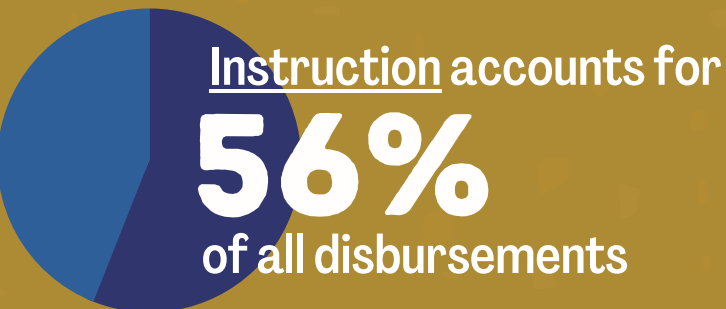

# OPERATIONS

- The district received a Clean Diesel grant which fully funded an electric bus and partially funded the charging station
- The district is adding and/or upgrading safety features across all campuses to include keyless door entry, film barriers on all entry area glass, visibility barriers in targeted areas, additional interior and exterior cameras, and increased licensed mental health provider (LMHP) services
- Staff completed ALICE (Alert, Lockdown, Inform, Counter, Evacuate) active shooter response training
- Increased Licensed Mental Health Provider (LMHP) services for students

## General Fund Expenditures

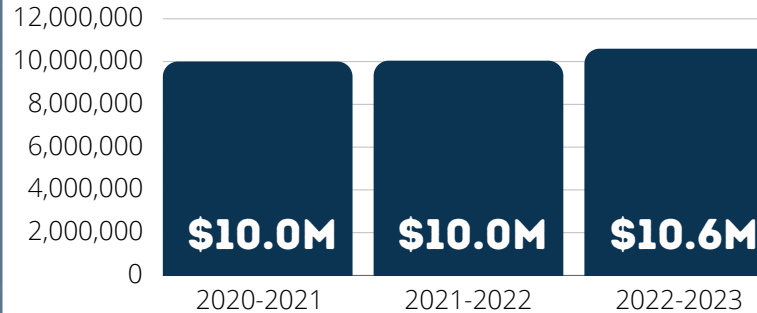

2021-2022 includes \$400K in transfers to depreciation/employee benefit

## Total Levy - By School Year

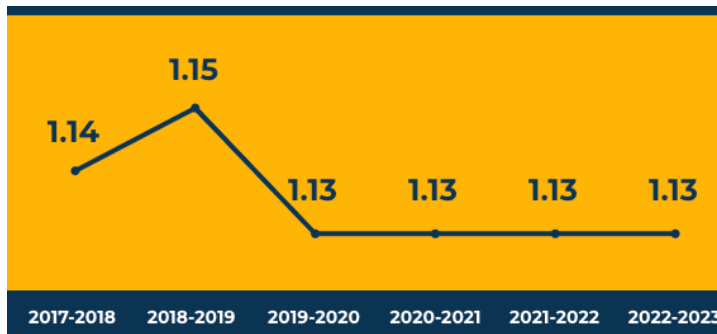

## Student Demographics

	Raymond Central	State Avg.
Free/Reduced Lunch	18.9%	46.7%
Special Education	13.4%	16.5%
English Language	0.0%	8.4%

## Student Enrollment

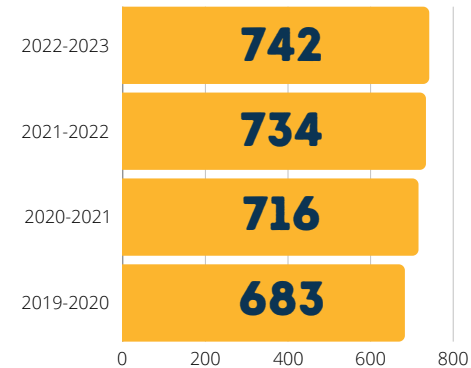

Discuss, Consider and Take Necessary Action to approve curriculum proposals for Baking and Pastry, General Biology (dual credit), Anatomy and Physiology (dual credit), and Summer School Credit Retrieval

Four curriculum proposals have been reviewed by the Curriculum and Americanism Committee: Baking and Pastry, Summer School Credit Recovery Program, General Biology (dual credit), and Anatomy and Physiology (dual credit). There is relatively little cost to the District as the expenses for the dual credit courses are recouped through Southeast Community College. The only cost to the district is for the summer school credit retrieval which is nominal. Motion by Lange, second by Burklund to approve curriculum proposals as presented. RCV 4-0. Motion carried.

# RAYMOND CENTRAL PUBLIC SCHOOLS CURRICULUM/PERSONNEL PROPOSAL

**DATE: 1/30/2024**  
**BUILDING: Jr/Sr Building**  
**Parks and Mark Smith**

**SCHOOL YEAR: 2024-2025**  
**PROPOSED BY: Rebecca**

---

## **PROPOSAL(including rationale): Adding course “Baking and Pastry”**

Addition of the course ‘Baking and Pastry’. We are currently offering the following courses in the career pathway for Culinary Arts and Event Planning and the highlighted course is the proposed course and it’s function in the pathway configuration. Perkins funding is based on completers within a CTE pathway and that does have some financial impact on the school but it is not considerable since we are not a stand alone program but in a consortium.

- A. Fundamentals of Food and Nutrition (Introductory Course)
- B. Culinary I (Intermediate Course)
- C. Culinary II (Capstone Course)
- D. Baking and Pastry (Capstone Course)**

The proposal would add another course to the pathway as a capstone course. Many students are interested in baking skills and already bake at home. This course would allow students to build skills from the basic knowledge they currently have. Students have expressed interest in a baking course in the past.

Currently there are high numbers of students enrolled in Food and Nutrition courses. This year the enrollment across all sections of Foods and Nutrition and Culinary Courses is 81 students.

### **STAFF NEEDS:**

There will be no additional staffing required for this addition nor will it impact the courses already being offered. It is our premise that students that are currently in Culinary II for their capstone course may choose Baking and Pastry for their capstone, thus offsetting the number of offered sections. This course will run every other year opposite of Culinary II.

### **FACILITY NEEDS:**

The current FCS room would be able to meet the need for this proposal.

### **MATERIALS/SUPPLIES NEEDED:**

There would be no additional equipment, supplies, or curriculum materials needed for this course. We should have all that is required as it is used in other courses. Students would be charged a fee for this class which is consistent with Culinary II fee.

### **NUMBER OF STUDENTS AFFECTED/TARGET GROUP AFFECTED:**

Estimating 12 students in the course.

### **TOTAL ESTIMATED COST:**

No additional cost

# RAYMOND CENTRAL PUBLIC SCHOOLS CURRICULUM/PERSONNEL PROPOSAL

**DATE: 1/31/2024**  
**BUILDING: Jr/Sr Building**

**SCHOOL YEAR: 2023-2024**  
**PROPOSED BY: Mark Smith**

---

## **PROPOSAL(including rationale): Summer Credit Recovery**

I propose that Raymond Central offer a summer school credit recovery program for the summer of 2024.

This program would utilize our current online credit recovery curriculum (Apex Learning) to provide opportunity for high school students to recover course credit. This would focus on core graduation requirements such as Math, English, Science, and Social Studies courses. Students would be eligible to take up to two courses in the summer school session that they had previously attempted during the regular school year, but did not earn credit.

This program would give first priority to students completing or entering their fourth year of high school, with the goal of helping them complete graduation requirements within their fourth year. Secondary priority would be to offer options to students in grades 9-11 that could benefit from recovering credit in a summer session.

The expected positive outcomes would include:

- A. Increasing opportunities for on-time graduation.
- B. Mitigating larger class sizes during the regular school year by reducing number of students retaking required classes.

The proposed summer school session would run from 6/3 - 6/27, Monday through Thursday (16 days). The session would run as a morning session 9:00am - noon.

**STAFF NEEDS:** Equivalent of one summer school certificated staff member would be needed to supervise and facilitate this program.

**FACILITY NEEDS:** Various spaces at the JH/HS building could be used for this program (Mustang Room or a larger classroom).

**MATERIALS/SUPPLIES NEEDED:** We would use our existing Apex Learning platform to deliver the instructional program. This would require students to use

their existing Chromebook devices. No additional materials or supplies would be needed.

**NUMBER OF STUDENTS AFFECTED/TARGET GROUP AFFECTED:** We estimate being able to offer this program to 20-25 students in a summer session.

**TOTAL ESTIMATED COST:**

Cost of staff member paid at student contact summer rate for approximately 48 instructional hours + an additional 6 hours for planning/prep/finalizing and submitting grades

54 hours x \$45/hour = \$2430

# RAYMOND CENTRAL PUBLIC SCHOOLS CURRICULUM/PERSONNEL PROPOSAL

**DATE:** 1/30/24  
**BUILDING:** Jr/Sr Building  
Osten, Mark Smith

**SCHOOL YEAR:** 2024-2025  
**PROPOSED BY:** Tasha

---

## **PROPOSAL: Dual Enrolled General Biology (our Advanced Biology)**

- 1. How does this proposal align with current course offerings?**
- 2. What data indicates that this course should be added?**
- 3. What data exists to indicate that this course can be successfully sustained?**
- 4. Does the course offering infringe on the viability of existing courses/programs?**

Mrs. Aylward has taken the necessary coursework to offer Advanced Biology as a dual enrolled class. Some students may desire to take this as a dual enrolled course to advantage them in their college studies. All bachelor degree areas require some general education courses and this course will meet that need for many students. We believe that we can sustain this course as we can actually instruct this course concurrently with Advanced Biology that is not dual enrolled.

## **STAFF NEEDS AND ESTIMATED COST:**

- 1. Will this impact staffing of existing courses?**

This will not affect staffing. Students currently enrolling in Advanced Biology will have an option of taking it for dual credit.

## **FACILITY NEEDS:**

No additional facility needs.

## **MATERIALS/SUPPLIES NEEDED AND ESTIMATED COST :**

There is the potential for new books being necessary. That is estimated at 10 students at the cost of \$159 per book. That cost would be covered by the AP Funds which is an activity account that all of our dual credit textbooks are purchased from. The funds from this account are generated from money that the district receives from the post secondary institutions that we run dual credit through. We also have unspent funds in the College Access Grant that helps defray these costs. There is no cost to the general fund budget.

## **NUMBER OF STUDENTS AFFECTED/TARGET GROUP AFFECTED:**

Estimate of 15 students interested in Advanced Biology for dual credit.

## **TOTAL ESTIMATED COST:**

No cost to the general fund.

# RAYMOND CENTRAL PUBLIC SCHOOLS CURRICULUM/PERSONNEL PROPOSAL

**DATE:** 1/30/24  
**BUILDING:** Jr/Sr Building  
Aylward, Mark Smith

**SCHOOL YEAR:** 2024-2025  
**PROPOSED BY:** Megan

---

## **PROPOSAL: Anatomy and Physiology as Dual Credit**

- 1. How does this proposal align with current course offerings?**
- 2. What data indicates that this course should be added?**
- 3. What data exists to indicate that this course can be successfully sustained?**
- 4. Does the course offering infringe on the viability of existing courses/programs?**

We currently offer Anatomy and Physiology and this will allow us to offer dual enrollment to the students that would desire that option. Students that are dual enrolled can be taught concurrently with those that are not dual enrolled so this does not need to add a need for any additional sections.

## **STAFF NEEDS AND ESTIMATED COST:**

- 1. Will this impact staffing of existing courses?**

There will be no additional staffing needs as a result of adding this dual enrolled course.

## **FACILITY NEEDS:**

There will be no additional facility needs as a result of adding this dual enrolled course.

## **MATERIALS/SUPPLIES NEEDED:**

There is the potential for new books being necessary. That cost would be covered by the AP Funds which is an activity account that all of our dual credit textbooks are purchased from. The funds from this account are generated from money that the district receives from the post secondary institutions that we run dual credit through. We also have unspent funds in the College Access Grant that helps defray these costs. There is no cost to the general fund budget.

## **NUMBER OF STUDENTS AFFECTED/TARGET GROUP AFFECTED:**

Estimated 8-10 students

## **TOTAL ESTIMATED COST:**

No additional cost to the general fund

Discuss, Consider and Take Necessary Action to approve amendments to 6000 policies

Motion by Lange, second by Benes to approve amendments to Board policies in Series 6000-Instruction: 6010-Scope of Instructional Program; 6110-School Instructional Hours; 6112-School Day for Students; 6115-Fire Drills, Emergency Plans; 6121-Curriculum Review Cycle; 6200-Objectives of the Instructional Program; 6201--Curriculum Decisions; 6201A-Curriculum Decisions/Regulation; 6213-Reading Instruction and Improvement; 6214-Assessment Security; 6215-Collection of Information Relating to Dyslexia; 6230-Curriculum Guides; 6241-Purpose of Homework; 6283-Concussions; 6283A-Return to Learn Protocol; 6283B-Concussions/NDE Bridging the Gap; 6283C-Concussions/NDE Bridging the Gap Appendix; 6285-Student Participation in Athletic Contests; 6287-Plagiarism, Copyrights and Patents; 6288-Artificial Intelligence; 6290-Dedications and Commencement; 6320-Parent Requests for Exclusion; 6361-Acknowledgment of Religious Holidays; 6362-Religion in the Curriculum; 6391-Controversial Issues in the Classroom; 6400-Parental/Community Involvement in Schools; 6400A-Complaint Form; 6800-Computer/Internet Safety; 6910-Dispensing Medications; and 6930-Behavioral Points of Contact. RCV 4-0. Motion carried.

**Scope of Instructional Program**

- A) The District shall provide instruction suitable to the needs of all who are legally eligible to attend school in the District.
- B) Except for special types of instruction, the instructional program may be arranged in units commonly designated as grades, each grade approximately the work of one (1) year. Such a program of instruction shall be organized into schools or other administrative units as follows:
1. The elementary school shall provide for the instruction of children kindergarten through fifth grade.
  2. The secondary school shall provide for the instruction of children in grades six (6) through twelve (12). Within the secondary school grades six (6), seven (7) and eight (8) may be treated as separate from grades nine (9) through twelve (12).
  3. Instruction appropriate to the needs of the community and individuals may be provided for adults and others beyond the age required to attend school.
  4. Departures from the above noted organizational plan for instruction may be made by the Superintendent of Schools upon approval of the Board of Education.

Date of Adoption: May 18, 2001

### School Instructional Hours

Raymond Central Public Schools will have a school year consisting of at least (a) for kindergarten, the time equivalent to 400 hours; (b) for elementary grades one through grade eight, the time equivalent to 1,032 hours, and (c) for grades nine through twelve, the time equivalent to 1,080 hours.

An instructional hour shall mean a period of time at least sixty (60) minutes, which is actually used for the instruction of students.

Interruptions in the school year of the instructional hour minimums due to extracurricular activities (interscholastic sports, clubs, and contests) will be held to a minimum. All students participating in such events will be required to comply with the District's policies on student attendance for such absences to be excused, including the completion of assignments for missed classes. ~~Extracurricular activities shall be defined as school events that involve student participation and faculty sponsorship. Interscholastic sports, clubs, and events shall be defined as school activities that involve student participation (one or more students) and faculty sponsorship. Activities so defined include: Volleyball, Football, Basketball, Wrestling, Track, Journalism, Music, Speech, Play Production, Baseball, FFA, FBLA, Skills USA, and Destination Imagination.~~

The required 1,080, 1,032, and 400 instructional hour minimums shall not include the following:

- ~~1. School Lunch Time~~
- ~~2. Passing Time Between Classes~~
- ~~3. Emergency School Closings~~
- ~~4. Time required for traveling to, traveling from, and participation in interscholastic sports, clubs, and events as defined in this policy when 15% or more of the student body is absent due to participation in such activities.~~
  1. When a school is dismissed for any reason such as tournaments or contests, parent/teacher conferences, funerals, parades, and school picnics;
  2. Time scheduled for the school lunch period.

Legal Reference: Neb. Rev. Stat. § 79-101; Neb. Rev. Stat. §§ 79-211 and 79-212; NDE Rule 10

Date of Adoption: May 18, 2009

**School Day for Students**

The school day shall be scheduled in such a way that students are given the best opportunity for their educational growth and development. The length of the day, and the arrangement of time segments within it, need not be uniform for all grade levels.

- A) The length of the school day in the secondary schools shall be **determined by the administration with approval from the board and at a minimum fulfill statutory requirements.** ~~no less than 380~~ **368** ~~minutes.~~
- B) The hours of opening and closing each type of school shall be determined by the Superintendent of Schools. The time of opening and ending the school day may be modified where transportation or other conditions justify such a change upon the authorization of the Superintendent of Schools provided that the length of school sessions are not shortened.
- C) During the school year, all schools shall be in session five (5) days a week, Monday through Friday, except upon emergency authorization of the Superintendent of Schools or during authorized school breaks.
- D) In designing the student day, the following considerations are to be met:
1. The learning activities of each student are carefully guided and supervised.
  2. Each student has opportunities to receive individual assistance from teachers outside of the regular school day.
  3. Parents shall be informed of late starts or early dismissal.
  4. Early dismissal for student employment shall be subject to approval of the building administration. Parental or guardian permission shall precede any early dismissal for work related activities. Early dismissal of other students shall be for reasons of health, etc., and must be validated by the student's parent or guardian.
  5. Changes in the school day shall be subject to the approval of the Superintendent.

Date of Adoption: May 18, 2009

**Fire Drills**

Fire drills shall be conducted at such times and manner as is required by the State Fire Marshal.

The frequency of fire drills shall be as follows:

- at a sufficient frequency to familiarize occupants with the drill procedure as a matter of routine;
- every month in each school building in which the facility is in session;
- subject to the exception that a monthly drill may be deferred in months of severe weather, provided that the required number of annual drills is achieved and not less than four are conducted before the drills are deferred; and
- one additional drill shall be conducted within the first 30 days of a school year.

The manner of conducting fire drills shall be as follows:

- emphasis shall be on conducting an orderly evacuation, rather than speed;
- under varying conditions and at expected and unexpected times;
- participants shall relocate to a predetermined location and remain until recalled or dismissed; and
- all emergency and relocation drill alarms shall be sounded.

**Crisis Plans**

Crisis Plans for emergency responses and directions for tornado, evacuation, lockdown, lockout, shelter in place and fire drill activities have been developed. ~~To be in compliance with the fire code, there are to be nine fire evacuation exercises each school year.~~ Two tornado drills are to be exercised and two lockdown drills practiced each school year.

Since many parents may not be at home, all children and faculty will be normally retained at the school building in case of extreme emergency. The school notification system will be activated to inform parents and guardians regarding where children may be picked up at school or at the evacuation site.

Legal Reference: Neb. Rev. Stat. § 79-706

Date of Adoption: May 18, 2009

Date of Revision: July 15, 2015

**Curriculum Review Cycle****TEXTBOOK ADOPTION SCHEDULE**

<u>EVALUATION</u>	<u>IMPLEMENTATION</u>	<u>SUBJECT</u>
2022-2023	2023-2024	English Language Arts
2023-2024	2024-2025	Character Education/School Counseling Art, Music, PE, Health, Business
2024-2025	2025-2026	Math
2025-2026	2026-2027	Science
2026-2027	2027-2028	World Language, Journalism
2027-2028	2028-2029	Social Studies, Gifted
2028-2029	2029-2030	Industrial Technology, FCS, Ag
2029-2030	2030-2031	Repeat the cycle

**This is Legal Counsel version:**

<del>2021-2022</del>	<del>2022-2023</del>	<del>Social Studies</del>
<del>2022-2023</del>	<del>2023-2024</del>	<del>Art, Music, Health 7-12, and Journalism</del>
<del>2023-2024</del>	<del>2024-2025</del>	<del>Industrial Technology, FCS</del>
<del>2024-2025</del>	<del>2025-2026</del>	<del>Spanish</del>
<del>2025-2026</del>	<del>2026-2027</del>	<del>Language Arts</del>
<del>2026-2027</del>	<del>2027-2028</del>	<del>Science</del>
<del>2027-2028</del>	<del>2028-2029</del>	<del>Math and Accounting</del>
		<del>Repeat the Cycle</del>

- Periodic Review of Curricular Areas integrated in Curriculum include Multicultural Education, Gifted Education, Remedial/Title Services, Technology, and Safety
- Raymond Central Curriculum will be revised as needed to comply with State Standards and State and Federal Regulations.

Date of Adoption: May 18, 2009

Date of Revision: June 15, 2022

**Objectives of the Instructional Program**

Raymond Central Public Schools has designated as its objectives the following.

Our school shall enable each student to react to his environment as a total being by:

- A. Aiding each student in acquiring fundamental skills and knowledge that will engender in each student a sense of personal worth and direction most beneficial to himself and society. This shall be accomplished through:
  1. Selection and using subject matter and facilities appropriate to the development of specific skills and knowledge.
  2. Setting standards of achievement so that every student can experience some degree of success.
  3. Providing equal opportunities for all students, fully realizing that not all students have the same talents and capacities for learning.
  4. Finding relationships which exist among the curricular studies.
  5. Finding relationships which exist between the curricular studies and the extra curricular activities.
  6. Aiding the student to recognize the value of the past as a developmental influence on aesthetic, humanistic and creative ideas for the future.
  7. Recognizing scholastic achievement and marks of improvement.
  8. Recognizing social and civic contributions made by students.
- B. Providing an environment in which freedom is regarded as a responsibility for administrators, teachers, and students. This shall be accomplished through:
  1. Providing direction and substantial meaning whereby respect for each other shall be paramount and reciprocal.
  2. Emphasizing the necessity of respect for public and private property as well as dignity of all work.
- C. Maintaining an environment conducive to good physical and mental health. This shall be accomplished through:
  1. Providing activities which have as their goal the development of physical fitness.
  2. Providing activities in which all students can experience some measure of success.
  3. Allowing for creative response through music, art, dramatics and physical education.
  4. Providing programs of specialization to meet specific needs of the student; such as speech therapy, remedial reading, guidance counseling and student health.

- D. Providing a means of public relations. This shall be accomplished through:
1. Keeping the public informed as to current happenings in all phases of the school's activities.
  2. Allowing the public to participate in the development of the school policies and programs.
  3. Making available to the public opportunities to discuss current educational interests.
  4. Attempting to develop good relationships among students, teachers, administrators, parents and the community at large.
- E. Selecting for employment, administrators and teachers who have the inspiration, dedication and factual competence to put into effect the philosophy and objectives of Raymond Central Public Schools. This shall be accomplished through the auspices of the administration and the Board of Education as designated by the procedures set forth in the Board Policies of the Raymond Central Public Schools.
- F. Establishing a program of continuous evaluation of the entire school system that might determine the measure of success of the philosophy and the objectives of Raymond Central Public Schools. This will be accomplished by coordinating the evaluative efforts of the students, teachers, administrators, specialists, and the entire community ~~through (Climate Surveys).~~

Date of Adoption: May 18, 2009

### Curriculum Decisions

The Superintendent, with involvement of the community, and the instructional staff, shall develop and periodically update a statement which reflects the community's purposes for its schools. These purposes shall be described as broad goals which state what the District expects students to know and be able to do as a result of their education. This statement, which will be called "Raymond Central Public Schools Goals for Students," will be used by staff to develop curriculum and course objectives and to plan instructional programs and projects for students.

This statement shall be approved by the Raymond Central Board of Education.

Subject to any overriding federal or state curriculum directives, the District shall retain complete authority, control and discretion in the establishment and regulation of its curriculum. As such, District classrooms or other instructional areas are not open or public forums. District classrooms or other instructional areas are reserved for the intended purpose of teaching the prescribed curriculum. Curriculum includes the range of courses or instructional programs that the District makes available to students; the course of study, the sequence of study, course objectives, course content, textbooks, all classroom or other instructional area materials and displays, the use of outside or supplemental materials, teaching methods, instructional practices, instructional plans, testing, testing protocols, assessment of student achievement, classroom assessment, the District assessment program, assessment of learning climate, the school improvement process (SIP), District research, student grading and student progress reports, graduation and promotion requirements; and the totality of activities, materials, procedures and instructional resources used throughout the District.

Staff shall follow the District curriculum. The Associate Superintendent for Instruction or a designee shall approve all modifications to District curriculum. Staff shall also follow all administrative curriculum directives.

The Superintendent along with the instructional staff shall develop periodic updates to curriculum which reflects the community's purpose for its schools. Community involvement may be allowed for advisory purposes, however, the ultimate decision will be at the Superintendent level. These updates shall be broad goals which will be used by staff to develop curriculum and course objectives and to plan instructional programs for students.

Legal Reference: NDE 10

Date of Adoption: [Insert Date]

## Curriculum Decisions

### Approval for Use of Curriculum Materials

The **Superintendent and his/her designee** ~~director of early childhood or the curriculum and instruction director~~ shall be responsible for recommending, through the Associate Superintendent for Instruction, approval of the basic and supplementary curriculum materials for each subject area.

1. The materials and resources which are a) supportive of District curriculum objectives and b) approved for use in the classroom will be identified in curriculum guides or otherwise given written approval by the **Superintendent and his/her designee** ~~curriculum and instruction director or director of early childhood~~. All such materials will be evaluated in accordance with district criteria for the selection of curriculum materials.
2. These approved resources will be identified as basic or supplementary. All schools are expected to use the basic resources unless the principal, in conjunction with the **Superintendent** ~~curriculum and instruction director~~, makes other arrangements. Supplementary resources are those which may be used by schools as additional references in the classroom.

Staff members selecting resources not currently on approved lists shall, prior to use, review these resources to ensure they support District curriculum and fulfill District criteria for the selection of curriculum materials. If, as a part of this review, questions are raised about the appropriateness of the materials, staff members are expected to discuss these concerns with their principal or his/her designee. Principals, in turn, are encouraged to consult with the **Superintendent** ~~curriculum and instruction director or the respective subject area curriculum specialist~~.

Date of Adoption: [Insert Date]

### **Reading Instruction and Improvement**

The District shall develop its curriculum to facilitate reading instruction and intervention services to address student reading needs, including, but not limited to, dyslexia. In doing so, the District will ensure that all teachers for kindergarten through grade three should be effective reading teachers as evidenced by (a) evaluations based on classroom observations and student improvement on reading assessments or (b) specialized training in reading improvement. Each student and his or her parents or guardians will be informed of the student's reading progress. It is the District's intent that each student in the District be able to read at or above grade level by third grade.

For school year 2019-20 and each school year thereafter, the District shall administer an approved reading assessment three times during the school year to all students in kindergarten through grade three, except for any student receiving specialized instruction for limited English proficiency who has been receiving such instruction for less than two years, any student receiving special education services for whom such assessment would conflict with the individualized education plan, and any student receiving services under a plan pursuant to the requirements of Section 504 of the Rehabilitation Act of 1973 or Title II of the Americans with Disabilities Act, for whom such assessment would conflict with such section 504 or Title II plan. The first administration of such assessment for each such school year shall occur within the first thirty days of the school year.

Any student in kindergarten, grade one, grade two, or grade three shall be identified as having a reading deficiency if such student performs below the threshold level determined pursuant to the Reading ~~Improvement Intervention~~ Act. A student who is identified as having a reading deficiency pursuant to the Reading ~~Improvement Intervention~~ Act shall remain identified as having a reading deficiency until the student performs at or above the threshold level on an approved reading assessment. Nothing in the Nebraska Reading Improvement Act shall prohibit the District from identifying any other student as having a reading deficiency.

1. The District will provide a supplemental reading intervention program for the purpose of ensuring that students can read at or above grade level at the end of third grade. The District may work collaboratively with a reading specialist at the State Department of Education, with educational service units, with learning communities, or through interlocal agreements to develop and provide such supplemental reading intervention programs. Each supplemental reading intervention program shall:
  - (a) Be provided to any student identified as having a reading deficiency;
  - (b) Be implemented during regular school hours in addition to regularly scheduled reading instruction unless otherwise agreed to by a parent or guardian; and
  - (c) Make available a summer reading program each summer for any student who has been enrolled in grade one or higher and is identified as continuing to have a reading deficiency at the conclusion of the school year preceding such summer reading program. Such summer reading programs may be held in conjunction with existing summer programs in the school district or in a community reading program not affiliated with the school district or may be offered online.
2. The supplemental reading intervention program may also include:
  - (a) Reading intervention techniques that are based on scientific research and best practices;
  - (b) Diagnostic assessments to frequently monitor student progress throughout the school year and adjust instruction accordingly;
  - (c) Intensive intervention using strategies selected from the following list to match the weaknesses identified in the diagnostic assessment:

- (i) Development in phonemic awareness, phonics, fluency, vocabulary, and reading comprehension;
- (ii) Explicit and systematic instruction with detailed explanations, extensive opportunities for guided practice, and opportunities for error corrections and feedback; or
- (iii) Daily targeted individual or small-group reading intervention based on student needs as determined by diagnostic assessment data subject to planned extracurricular school activities;
- (d) Strategies and resources to assist with reading skills at home, including parent-training workshops and suggestions for parent-guided home reading; or
- (e) Access to before-school or after-school supplemental reading intervention with a teacher or tutor who has specialized training in reading intervention.

The school of any student who is identified as having a reading deficiency shall notify such student's parents or guardians either in writing or by electronic communication no later than fifteen working days after the identification of the reading deficiency that the student has been identified as having a reading deficiency and that an individual reading improvement plan will be established and shared with the parents or guardians.

Any student who is identified as having a reading deficiency shall receive an individual reading improvement plan no later than thirty days after the identification of such reading deficiency. The reading improvement plan may be created by the teacher, the principal, other pertinent school personnel, and the parents or guardians of the student and shall describe the reading intervention services the student will receive through the supplemental reading intervention program pursuant to **this Policy section 24** of this act to remedy such reading deficiency. Each such student shall receive reading intervention services through the supplemental reading intervention program pursuant to section 24 of this **Policy act** until the student is no longer identified as having a reading deficiency.

Legal Reference: **Nebraska Reading Improvement Act, Neb. Rev. Stat. Sec. 79-2601** ~~Nebraska Reading Intervention Act~~

Date of Adoption: June 4, 2018

## Assessment Security

### 1. State Assessment

The Raymond Central Public School District has adopted an assessment plan and has aligned the curriculum with the state approved content standards. The assessment plan includes a schedule and procedures for assessing success in achieving state standards.

Educators are to clearly articulate the learning targets and align instruction to the learning targets within each of the content standards. Teachers are to give students instruction on the content prior to students being assessed on each content standard in order to provide learning opportunities for all students.

The assessments are to be conducted in accordance with the assessment plan schedule. Teachers are to conduct the assessments in a manner that assures it accurately assesses whether or not students are meeting the targets outlined by the content standards.

Assessment results are to be reported by the school buildings/district in the manner and within the time directed by the administration or designee. The assessment data is to be used to meet state standards, to provide students and parents with information about student progress, to enhance school improvement planning, and to improve instruction.

The assessment data is to be evaluated by teachers to monitor student learning and to improve instruction or terminate ineffective teaching practices to ensure students are being given the opportunity to meet the standards.

### 2. Achieving Valid Assessments

Educators are responsible for maintaining the integrity of the assessments to ensure that assessments provide a valid measure of student progress and accomplishments. Educators are not to engage in any practice that may result in assessment results that do not reflect student learning, knowledge, skills or abilities in the area assessed.

For purposes of this policy, student assessments include both “standardized assessments” (including state assessments, norm referenced tests, and evaluations conducted for special education eligibility) and state assessments.

The following specific assessment expectations and rules apply:

- a. Integrity of the Assessment Instrument. The integrity of the assessment instrument is to be maintained.

Standardized assessment instruments are not to be made available to students at any time before the student takes the assessment. The assessment instrument is to be maintained in a secure manner.

- b. Teaching for Success on Assessments.  
It is appropriate for educators to prepare students to do well on assessments. This is to be accomplished in a manner that assures the assessment accurately reflects the student’s knowledge, and not simply test preparation.

- i. Teach the Content. Educators are to prepare students to do well on assessments by

teaching the subject content. Educators are not to “teach to the test” by teaching based solely on the content of the assessment. The content is to be taught to the students over an appropriate amount of time prior to the assessment. “Cramming” assessment content just before the assessment is to be taken is not appropriate. Review of content previously taught is appropriate.

- ii. Practice Tests. Educators are to prepare students by teaching test taking skills independent of the subject matter being assessed. Educators are to conduct reviews (drills) using district approved practice assessments.

c. Conditions for Successful Assessments.

- i. Communications. Educators are to communicate to students and parents when assessments will be administered, the purpose of the assessment and how the assessment results will be used. Educators are to motivate students to do their best on assessments. Educators are to read and be familiar with assessment administration directions in advance and communicate the rules to students accurately and clearly.

- ii. Climate. Educators are to have sufficient assessment materials available (e.g., No. 2 pencils, if needed). The classroom is to be arranged to allow comfortable seating. Distractions are to be eliminated. Educators in nearby classrooms are to be informed that the assessment is to be administered so noises from neighboring classrooms are kept at a minimum. Activities or arrangements are to be made for students who finish early so such students do not cause a distraction to other students still taking the assessment.

- iii. Security. Educators are to monitor students while administering assessments to ensure students are complying with standards of academic integrity. Students who violate standards of academic integrity are to be reported to the administration.

- d. Full Participation. Educators are to make efforts to have all eligible students take the assessments. The educator should develop a list of students who will be exempted from assessment and the reason for the exemption and submit the list for review and approval by the Principal.

e. Assistance During Assessments.

Standardized Assessments. Educators are not to provide assistance to students while a standardized assessment is being administered except as provided for in a student’s 504 Plan, IEP and/or testing protocols.

- f. Student Answers. Assessments are to reflect the students’ work as submitted by the students. During the assessments, educators are to monitor students to make sure directions are being followed (e.g., students are using a No. 2 pencil on all “bubble” sheet assessments and completely erase mistaken answers and extra marks on “bubble” sheet assessments). Educators are not to change answers on a student’s assessment sheet or otherwise participate in the submission of false or misleading assessment results.

All employees are to adhere to Nebraska’s Security Procedures and report breaches in security to the Superintendent or the Superintendent’s assessment designer for report to the Nebraska Department of

Education. Professionalism, common sense, and practical procedures provide the framework for testing ethics.

Violations of the rules and expectations set forth in this policy will be considered to be a breach of the District's standard of ethics and may result in disciplinary consequences. Educators are to report suspected violations of the expectation to the administration. The administration is to investigate and appropriately respond to violations of the expectations.

Legal Reference: NDE Rule 10.05; NDE Rule 27.004.02H and 004.03D

Date of Adoption: [Insert Date]

**Collection of Information Relating to Dyslexia**

The District will collect and maintain the following information relating to dyslexia during each school year:

- (1) Testing for a specific learning disability in the area of reading, including tests that identify characteristics of dyslexia and the results of such tests;
- (2) The number of students identified as having a reading issue, including dyslexia, pursuant to the assessment administered under the Nebraska Reading Improvement Act and Policy 6213;
- (3) The number of students identified in Paragraph (2) that have shown growth on the measure used to identify the reading issue; and
- (4) All other data required by law and/or the District's special education obligations.

By July 1st of each year, the District will provide the Nebraska State Department of Education with information collected about dyslexia, as requested by the Department.

Any student or parent/guardian with questions or concerns about dyslexia are encouraged to contact the District's Director of Special Education.

Legal Reference: **Neb. Rev. Stat. §§ 79-11,156 — 79-11,158 ~~LB 298 (2023)~~**

Date of Adoption: July 12, 2023

**Curriculum Guides**

Curriculum  **pacing guides and course**  guides shall be prepared in harmony with the legal requirement of the state and the purposes of the program of instruction adopted by the board.

The Superintendent shall have general coordinating authority over the formation of all courses of study and curriculum  **pacing guides and course**  guides.

Date of Adoption: May 18, 2009

**Purpose of Homework**

No hard and fast rules concerning homework can be made. Some generally accepted principles should govern the teacher in the assignment of homework.

1. There should be flexibility and differences in the assignment to individual students. These should stem from real needs and the consideration of the total education background of the individual student.
2. Homework should serve a definite purpose, to provide drill or practice on a principle or skill already taught; to provide real-life application of the matter in hand; to develop appreciation for or knowledge of community resources; or to develop the personal culture of the student.
3. Homework should be used as a technique for learning, not as "busy work."
4. Homework should not be **ordinarily** assigned as punishment.
5. Homework should not be used to replace or reduce supervised study, which should take place during school hours. This type of study usually achieves better results than homework.
6. Homework is more effective if a conference with the parent results in understanding of purpose and ways in which help at home can best be offered.
7. There should be a cooperative effort on the part of teachers to coordinate homework assignments so students are not overburdened with excessive quantities of homework.
8. Each teacher should teach students what to study and how to study.
9. Homework should be checked by the teacher and mistakes of students indicated for correction with individual comments wherever indicated or possible.

Date of Adoption: May 18, 2009

## Concussions

### 1. Training

The Superintendent or designee shall make available training approved by the chief medical officer of the State on how to recognize the symptoms of a concussion or brain injury and how to seek proper medical treatment for a concussion or brain injury to all coaches of school athletic teams.

### 2. Education

The Superintendent or designee shall require that concussion and brain injury information be provided on an annual basis to students and the students' parents or guardians prior to such students initiating practice or competition. The information provided to students and the students' parents or guardians shall include, but need not be limited to:

- a. the signs and symptoms of a concussion;
- b. the risks posed by sustaining a concussion; and
- c. the actions a student should take in response to sustaining a concussion, including the notification of his or her coaches.

### 3. Response to Concussions

- a. Removal. A student who participates on a school athletic team shall be removed from a practice or game when he or she is reasonably suspected of having sustained a concussion or brain injury in such practice or game after observation by a coach or a licensed healthcare professional who is professionally affiliated with or contracted by the school.
- b. Return-to-Play. A student who has been removed from a practice or game as a result of being reasonably suspected of having sustained a concussion or brain injury shall not be permitted to participate in any school supervised team athletic activities involving physical exertion, including, but not limited to, practices or games, until the student: (i) has been evaluated by a licensed healthcare professional, (ii) has received written and signed clearance to resume participation in athletic activities from the licensed healthcare professional, and (iii) has submitted the written and signed clearance to resume participation in athletic activities to the school accompanied by written permission to resume participation from the student's parent or guardian.

The coach or administration may require that the student's return to full activities be on a stepwise progression back to full participation, or otherwise establish conditions for return to participation that are more restrictive than those defined by the licensed health care professional if the coach or an administrator reasonably deems such to be appropriate.

The signature of an individual who represents that he or she is a licensed healthcare professional on a written clearance to resume participation that is provided to the school shall be deemed to be conclusive and reliable evidence that the individual who signed the clearance is a licensed healthcare professional. The school is not required to determine or verify the individual's qualifications.

- c. Parent Notification. If a student is reasonably suspected after observation of having sustained a concussion or brain injury and is removed from an athletic activity per the preceding paragraph, the parent or guardian of the student shall be notified by the Superintendent or designee of the date

and approximate time of the injury suffered by the student, the signs and symptoms of a concussion or brain injury that were observed, and any actions taken to treat the student.

- d. Return to Learn. The Superintendent or designee shall develop a return to learn protocol for students who have sustained a concussion. The return to learn protocol shall recognize that students who have sustained a concussion and returned to school may need informal or formal accommodations, modifications of curriculum, and monitoring by medical or academic staff until the student is fully recovered.

#### 4. Responsibility of Coaches

Coaches shall comply with this policy and apply their safety and injury prevention training. A coach who fails to do so is subject to disciplinary action, including but not limited to termination of employment.

#### 5. Students and Parents

It is recognized that coaches cannot be aware of every incident in which a student has symptoms of a possible concussion or brain injury. As such, students and their parents have a responsibility to honestly report symptoms of a possible concussion or brain injury to the student's coaches on a timely basis.

Legal Reference: **Neb. Rev. Stat. Sections 71-9102 to 71-9106** ~~Laws 2011, LB 260~~

Date of Adoption: August 15, 2011

Date of Revision: May 19, 2014

**Concussions: Return to Learn Protocol**

Students who sustain a concussion and return to school may need informal or formal accommodations, modifications of curriculum, and monitoring by medical or academic staff until the student is fully recovered.

The school administration of Raymond Central Public Schools adopts the NDE Guidance entitled “Bridging the Gap from Concussion to the Classroom” (2nd Edition)<sup>1</sup> and accompanying Appendix<sup>2</sup> as its return to learn protocol, with the recognition that each student who has sustained a concussion will require an individualized response.

Any student, parent or guardian who suspects that the student sustained a concussion must immediately inform the student’s coach or building administrator. If a student is suspected of having a concussion, the student may not be permitted to participate or practice in any school- sponsored activity.

The District encourages full cooperation and support from both students and parents in each student’s return to learn protocol.

<sup>1</sup><https://cdn.education.ne.gov/wp-content/uploads/2019/08/Return-to-Learn-Bridging-the-Gap-7.31.2019.pdf>

<sup>2</sup><https://www.education.ne.gov/wp-content/uploads/2017/07/BRIDGING-THE-GAP-Booklet-plus-Appendices.pdf>

Date of Adoption: June 10, 2020

Date of Revision: February 14, 2024

# BRIDGING THE GAP

From  
**CONCUSSION**  
To the  
**CLASSROOM**

February 2014



NEBRASKA DEPARTMENT OF EDUCATION

*Return  
to  
Learn*



## BRIDGING THE GAP FROM CONCUSSION TO THE CLASSROOM: RETURN TO LEARN



On April 8, 2011, the Nebraska Legislature passed the Concussion Awareness Act on a vote of 43- 0. The Concussion Awareness Act became effective in Nebraska on July 1, 2012. The goal of the Act is to provide a consistent means to identify and manage concussions and help ensure the safety of those involved in youth sports.

The Concussion Awareness Act contains the three tenets of model legislation as described by the Brain Injury Association and the National Football League.

1. Education: Coaches, Parents and Student Athletes
2. Removal from Play – If a concussion is reasonably suspected
3. Clearance by a Licensed Health Care Professional

While Nebraska law requires a specified Return to Play protocol, equally important in the academic setting is a Return to Activity policy. “Bridging the Gap from Concussion to the Classroom: Return to Learn” was developed to provide guidance to assist Nebraska school districts in developing a concussion management policy, including the provision of appropriate classroom adjustments for concussed students facing learning challenges.

Just as effective concussion management requires communication and collaboration, this document has been developed, reviewed and edited collaboratively by a Concussion Task Force comprised of Nebraska Brain injury School Support Teams (BIRSST) and the following individuals representing several disciplines:

**Nova Adams**, Educational Liaison, Madonna Rehabilitation Hospital

**Cindy Brunken**, Southeast BIRSST Team, Special Education Supervisor, Lincoln Public Schools

**Michelle Hawley-Grieser**, Parent, Nebraska Brain Injury Advisory Council

**Crystal Kjar**, Lincoln Southwest High School, Head Athletic Trainer

**Rusty McKune**, Coordinator, the Nebraska Medical Center, Sports Medicine Program

**Kody Moffatt**, MD, Pediatrics and Pediatric Sports Medicine

**Peg Ogea-Ginsburg**, Nebraska Department of Health and Human Services, Office of Injury Prevention

**Peggy Reisher**, Executive Director, Nebraska Brain injury Association

**Rose Dymacek**, Education Specialist, Nebraska Department of Education, Office of Special Education



## BRIDGING THE GAP FROM CONCUSSION TO THE CLASSROOM: RETURN TO LEARN

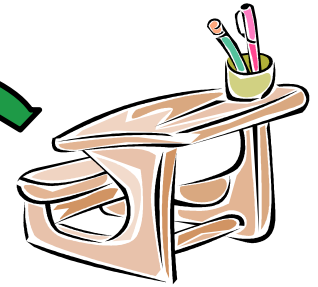

### What is a Brain Injury?

#### Acquired Brain Injury (ABI)

- An acquired brain injury is an injury to the brain, which is not hereditary, congenital or degenerative that has occurred after birth. (Includes anoxia, aneurysms, infections to the brain and stroke.)

#### Traumatic Brain Injury (TBI)

- A TBI is caused by a bump, blow or jolt to the head or a penetrating head injury that disrupts the normal function of the brain. Not all blows or jolts to the head result in a TBI. The severity of a TBI may range from "mild," i.e., a brief change in mental status or consciousness to "severe," i.e., an extended period of unconsciousness or amnesia after the injury. The majority of TBIs that occur each year are concussions or other forms of mild TBI.

#### Concussions

- A concussion is a type of **traumatic brain injury**, or TBI, caused by a bump, blow, or jolt to the head. A concussion is **any head trauma that causes an altered mental state that may or may not involve a loss of consciousness. Only 10 percent of concussions involve a loss of consciousness!**
- Concussions can also occur following a fall or a blow to the body that causes the head and brain to move back and forth quickly.
- This sudden movement can cause the brain to bounce around in the skull, stretching and damaging the brain cells and creating chemical changes in the brain.
- Health care professionals may describe a concussion as a "mild" brain injury because concussions are usually not life-threatening. Even so, their effects can be serious. (Centers for Disease Control & Prevention)



**A CONCUSSION  
IS  
A BRAIN INJURY!**

# Incidence of Youth Concussions in Nebraska

Figure 1. Concussion rates among persons aged 5-19 years, by month – Nebraska 2008-2012

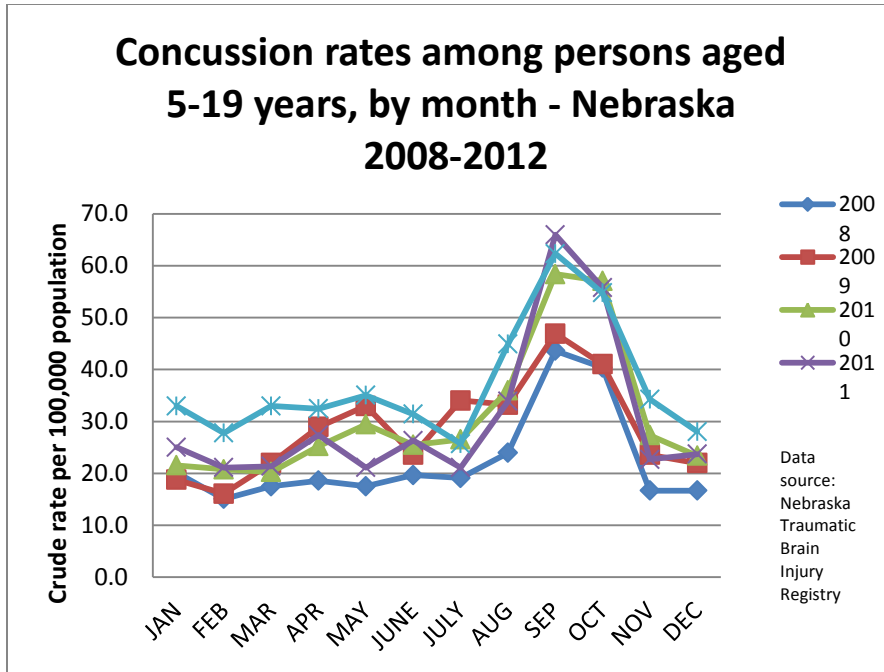
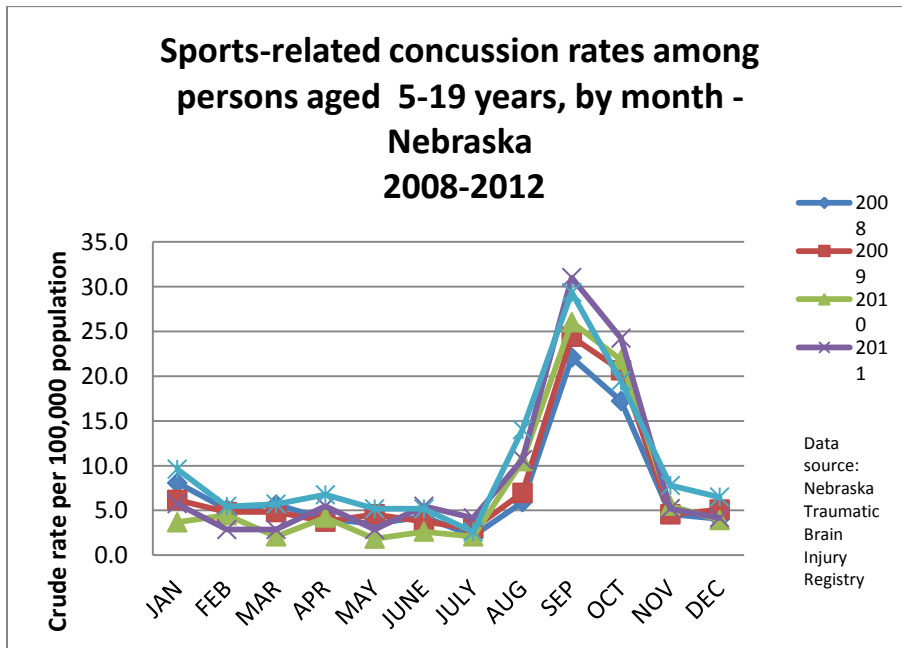

Figure 2. Sports-related concussion rates among persons aged 5-19 years, by month – Nebraska 2008-2012



**Nebraska Department of Health and Human Services, 2013**

Both figures above show a peak in concussion rates among school-aged Nebraskans in September and October. This trend has been consistent over the past 5 years. Figure 1 also shows that higher rates of concussions were diagnosed in 2012. These graphs represent persons treated in the office of a physician or psychologist or admitted to or treated at a hospital or a rehabilitation center located within a hospital in Nebraska.

## Why are Concussions Such a Big Deal?

- **A CONCUSSION IS A BRAIN INJURY!**
- A concussion can occur from an impact to the head. The most common cause of a concussion is a whiplash type injury, a rapid acceleration of the head.
- Most concussions (90%) occur without loss of consciousness!
- A “ding,” “getting your bell rung,” or what seems to be a mild bump, blow or jolt to the head can be serious and can change the way the brain normally works! (Center for Disease Control 2013).
- Because of changes in the neurophysiology of the brain, symptoms may continue to develop over the next few hours following an injury.
- After a concussion, among other effects, connections within the brain become stressed, resulting in the breaking of some connections between different brain areas and limiting the ability of the brain to process information efficiently and quickly. (Molfese 2013)
- These changes can lead to a set of symptoms affecting the student’s cognitive, physical, emotional and sleep functions, which may result in reduced ability to do tasks at home, at school, or work.
- During this time, returning to play or full-time academics before symptoms have cleared can result in **prolonged recovery time or risk of further injury.**
- Ignoring the symptoms and trying to “tough it out” often makes symptoms worse!
- “Second Impact Syndrome” may occur when a brain already injured takes another blow or hit before the brain recovers from the first –usually within a short period of time (hours, days, or weeks). A repeat concussion can slow recovery or increase the likelihood of having long-term problems. In rare cases, repeat concussions can result in edema (brain swelling), permanent brain damage and even death. (Center for Disease Control 2013)
- As the chemistry of the brain returns to normal, the symptoms begin to subside and for most people, they resolve within 1 to 6 weeks.
- **During the recovery period, it is very important that individuals are monitored for full resolution of symptoms and referred if further evaluation or treatment is needed.** (Terryberry-Spohr 2013)



## Symptoms of TBI/Concussion

School professionals can best support a student's return to school by understanding the effects of concussion and providing the needed academic adjustments and supports. Knowledge of concussion symptoms can help the student and the school team identify the specific needs of the student, monitor changes and provide appropriate accommodations to facilitate the student's recovery and minimize the pressure to return to activities too soon. (CDC 2013)

Symptoms of TBI/Concussion that may affect school performance fall into four categories:

- Thinking/Cognitive/Remembering
- Sleep
- Physical Symptoms
- Emotional/Mood Symptoms



### **Thinking/Cognitive Red Flags**

Look for increased difficulty with:

- Thinking clearly
- Concentrating, Staying on task
- Remembering new information
- Slowed response or processing of information (Feeling slowed down)
- Reduced academic performance



### **Sleep Red Flags**

Sleep symptoms tend to last longer than other symptoms. Look for increased:

- Drowsiness
- Sleeps more than usual
- Sleeps less than usual
- Difficulty falling asleep
- Fatigue – tired, having no energy

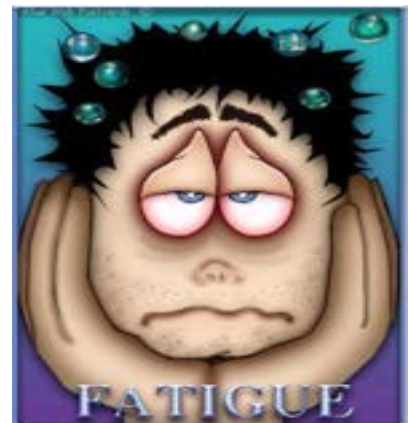



## Physical Red Flags

Look for increased difficulty with:

- Headaches
- Fuzzy or Blurred Vision (visual problems)
- Balance problems
- Dizziness
- Nausea, vomiting
- Sensitivity to light
- Sensitivity to noise
- Disorientation



## Social Emotional Red Flags

Look for increased difficulty with:

- Irritability
- Sadness
- More emotional
- Changes in mood
- Nervousness
- Anxiety



**Return to Activity = Return to Learn + Return to Play**



- The Center for Disease Control estimates that 1.7 million traumatic brain injuries occur annually and that 75% of those injuries are mild TBIs (concussions). Concussions occur from sports, falls, playground and bicycle accidents as well as motor vehicle accidents.
- Attention has been given to sports-related concussions because concussion laws have been passed in nearly every state and procedures for Return to Play are familiar to parents, schools and medical personnel.
- Equally important is Return to Learning in the classroom!
- After a concussion, the child or adolescent does not appear to be ill or physically injured. In fact, they may “look” just fine. Nonetheless, a concussion can have direct effects on learning and evidence suggests that using a concussed brain to learn may worsen concussion symptoms and may prolong recovery. (Halstead, McAvoy, et al 2013)
- As the brain is recovering, reducing demands on the brain and avoiding overexertion of the brain at home and at school through a reduction in physical and cognitive activity is beneficial to the recovery of the student
- **Every student and every concussion is different!** No two concussions are the same! The amount of time needed between the injury and the commencement of return to learn activities will vary not only between students, but also between concussions (should a student suffer more than one).
- A Return to Activity plan is composed of two parts:
  - Return to Academics – a gradual return to school and academic requirements implemented by the teaching staff
  - Return to Play – a gradual return to sports implemented by the athletic staff.
- Both the return to academics, and when appropriate, the return to play progression should be allowed to progress over time and as symptoms subside.
- **Please refer to the Return to Academics Progression and Return to Play Progression suggestions at the end of this document. \*\*\***

## Concussion Management: Recommended Best Practice for Nebraska Schools

- Once a concussion has been diagnosed by a healthcare professional, managing the concussion is best accomplished by creating a support system for the student/athlete. **Communication and collaboration** among parents, school personnel, coaches and athletic trainers, and healthcare providers in overseeing both the return to academics and return to play progressions is essential for the recovery process. Teamwork is required to adjust the treatment and management of the concussion. **Best practice indicates that the student should return to school with a RELEASE OF INFORMATION SIGNED BY THE PARENTS that allows for two-way communication between school personnel and the healthcare provider.** (McAvoy, 2012)

## A collaborative approach with the student as the CENTER OF FOCUS!

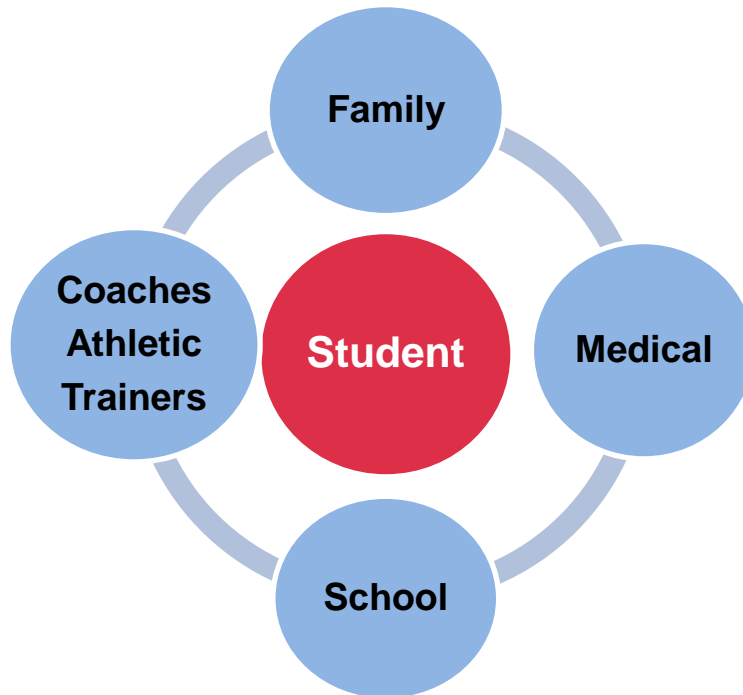

- Each school district creates a **Concussion Management policy** that incorporates:
  - **Knowledge** about concussion as a mild traumatic brain injury
  - **Training** for all coaches, athletes, parents, and school staff about concussion management
  - **A Concussion Management Team** with a designated contact person.



### The Concussion Management Team

#### Members may include:

**Health Care Professional\***  
**Parent(s)\***  
**School Administrator or designee\***  
Athletic Director  
Athletic Trainer  
Coach  
School Nurse  
Teacher(s)

Speech Language pathologist  
School Psychologist  
School Counselor  
Occupational Therapist  
Physical Therapist  
Student Athlete

**Essential members\***

## Concussion Management Team (CMT) Responsibilities:

- The CMT ensures that every student who suffers a concussion is monitored for a safe return to activity. The CMT designs the Return to Activity Plan with input from the healthcare provider.
- **CMT** contact person is notified of concussion (by parents or athletic trainers, coaches); CMT contact person notifies parent if concussion occurs during school activity;
- CMT contact person notifies school nurse, athletic trainer/coach and teachers as appropriate;
- **Assess** and document the physical, cognitive, behavioral, emotional and sleep **symptoms** and **needs** of a concussed student/athlete;
- Design an **individual plan** for schedule **adjustments**, supports, academic adjustments (i.e., reduced assignments) and physical activity, including PE, dance, active recess, as appropriate and share with school personnel, student and parents;
- **Teachers, Parents, Coaches, Medical providers & Student** communicate, monitor the effectiveness of the plan and document symptoms and academic progress;
- CMT (SAT) meets regularly to **review the student's symptoms and progress**, make adjustments and notifies school staff and health care professional of updates;
- **Adjustments continue until the student no longer needs academic adjustments as a result of the concussion;**
- CMT offers resources on concussions to parents;
- Contact **[Brain Injury Regional School Support Team \(BIRSST\)](#)** for assistance or resources;
- Follow a **gradual Return-to-Activity** for academics and athletics;
- **After symptoms subside and CMT certifies there are no academic concerns or adjustments needed and family and coaches agree student is symptom-free without medication, then**
- Written clearance from a medical provider is given if student/athlete is "back to baseline" on neurocognitive measures and
- Written permission for Return to Activity from parents is obtained;
- Student/athlete returns to academic activities without adjustments and begins Return to Play Protocol; **a successful Return to Learn is necessary before approval for Return to Play. (McAvoy, 2012).**
- Document concussion in student's education file;
- If symptoms last more than 3 – 4 weeks, follow-up assessment and academic adjustments may need to be strengthened or remain in place longer;
- If problems persist, academic accommodations and student supports may be provided through an (Response to Intervention (Rtl) Plan, a Health Plan or a 504 Plan;
- The majority of concussed students will not require an IEP; however, a small percentage of students may require a special education referral.
- Parents and medical professions seek medical explanation and treatment for slowed recovery and schools continue to provide appropriate supports.

- **Keep in mind that progression is individual for each student!**

## **Return to Learn BEFORE Return to Play!**

**If a student athlete continues to receive academic adjustments due to the presence of any symptoms, they should be considered symptomatic and not be allowed to resume physical activity.** McAvoy, Returning to Learn: Going Back to School Following a Concussion. Communique on line, April 2011.

### **Brain Injury Regional School Support Teams (BIRSST)**

- Nebraska has five regional BIRSST teams
  - Refer to attached **map** for **BIRSST team locations and contacts**
- BIRSST teams can assist school districts in:
  - Identifying strategies to support student success
  - Providing information on brain injury and resources
  - Providing training and consultation for Concussion Management Team



### **Tips for Teachers**

Symptoms of concussion often create learning difficulties for students. Immediately after diagnosis of a concussion, an individualized plan for learning adjustments should be initiated with a gradual, monitored return to full academics as symptoms clear. Typical classroom adjustments and accommodations include:

- Reduce course workload
- Decrease homework
- Allow breaks during the day, i.e. rest in quiet area
- Allow additional time to complete assignments
- Provide instructor's notes, outline or study guide for student
- Avoid over-stimulation (noise and light)
- Avoid testing or completion of major projects during recovery time when possible



Refer to **Tips for Teachers** in Appendices for additional adjustments or accommodations.

## Tips for Parents

- Parents play a key role in maximizing the child's recovery from a concussion.
- Parents take student to ER or contact the child's healthcare provider immediately after the concussion.
- After the diagnosis of a concussion by the healthcare professional, parents monitor symptoms and activities at home.
- Parents enforce rest, both physical and cognitive, and ensure that the child receives sufficient sleep and engages in quiet, restful activities immediately after a concussion.
- Parents take student to follow-up appointments with the healthcare provider.
- For the first few days, the student/athlete may have symptoms that interfere with concentration and may need to stay home from school to rest for a day or two and refrain from:

- Watching TV
- Playing video games
- Texting
- Working/playing on computer
- Driving
- Use of Cell phone
- Blowing on a musical instrument
- Piano lessons



- Light mental activities can resume as long as symptoms do not worsen. When the student/athlete can tolerate 30-45 minutes of light mental activity, a gradual return to school can commence.
- Parents monitor and track symptoms at home and communicate regularly with the school Concussion Management Team (CMT) Coordinator and/or health care provider.
- Parents sign Permission for two-way Release Information between the medical provider and the school district.
- Parents may request information from the school CMT on concussions.
- Parents are aware of academic adjustments in the school setting.
- Deliver medical clearance from the healthcare provider to the CMT when appropriate.

## References

1. Centers for Disease Control and Prevention - *Returning to School After a Concussion: A Fact Sheet for School Professionals*.  
[http://www.cdc.gov/concussion/pdf/TBI\\_Returning\\_to\\_School-a.pdf](http://www.cdc.gov/concussion/pdf/TBI_Returning_to_School-a.pdf)
2. Giza C., Kutcher J., *et al.* Summary of evidence-based guideline update: Evaluation and management of concussion in sports. *Neurology*, 2013: 10.1212/WNL.0b013e31828d57dd.
3. Halstead, M., McAvoy, K., *et al.* *Returning to Learning Following a Concussion*. *Pediatrics*: originally published online October 27, 2013.  
<http://pediatrics.aappublications.org/content/early/2013/10/23/peds.2013-2867>
4. McGrath, N. (2010). Supporting the Student-Athlete's Return to the Classroom after a Sport Related Concussion. *Journal of Athletic Training*, 45(5), 492-498.
5. McAvoy, K. (2013). *REAP the benefits of good concussion management*. Centennial, CO: Rocky Mountain Sports Medicine Institute Center.
6. McAvoy, K. (2012). Return to Learning: Going Back to School Following a Concussion. *NASP Communique* online. March/April.
7. McCrory P., Meeuwisse W., Aubry M., *et al.* Consensus Statement on Concussion in Sport: the 4<sup>th</sup> International Conference on Concussion in Sport. *Br J Sports Med*. 2013; 47: 250-258
8. Orcas (2011). *Brain Injury 101: Concussion Management. Policy and Resource Handbook*. Retrieved from <http://brain101orcasinc.com>
9. The Center on Brain Injury Research and Training. *Max's Law: Concussion Management Implementation Guide*. Retrieved from <http://www.cbirt.org>

## WHAT CAN YOU DO TO CHANGE THE CULTURE OF CONCUSSION IN NEBRASKA?

- ✓ Educate
- ✓ Communicate
- ✓ Collaborate



- Parents
- Students
- Schools
- Physicians

# Wear your helmet!



**BRIDGING THE GAP**  
**From CONCUSSION To The CLASSROOM**

**APPENDICES**

**Nebraska Concussion Awareness Act – Quick Facts**

**Concussion Resources**

**Return to Academics Progression**

**Return to Play Progression**

**Post-Concussion Symptom Checklist**

**Tips for Teachers**

**NE Concussion Management Recommended Best  
Practice**

**Information from Teachers for CMT**

**BIRSST Team Map and Team Contacts**

# **Nebraska Concussion Awareness Act – Quick Facts**

## **Return to Play**

- **Goal: To provide a consistent means to identify and manage concussions and help ensure the safety of those involved in youth sports.**
- Legislation passed by Nebraska Legislature - Final Reading on April 8, 2011 (43-0)
- Effective July 1, 2012
- The Concussion Awareness Act contains the three tenets of model legislation as described by the Brain Injury Association and the National Football League.
  1. Education: Coaches, Parents and Student Athletes
  2. Removal from Play – If a concussion is reasonably suspected
  3. Clearance by a Licensed Health Care Professional
- Concussion Awareness Act applies to:
  - ✓ Approved or accredited public, private, denominational or parochial schools (does not include higher education/college and university) Section 4.
  - ✓ Athletes 19 years of age or younger that participate in organized sports (“any city, village, business or nonprofit that organizes sports, charges a fee or is sponsored by a business or nonprofit organization.”) Section 5
- Education provided for:
  - ✓ Coaches. Training approved by the Chief Medical officer must be made available to all coaches.
  - ✓ Parents and student athletes. Concussion and brain injury information must be provided:
    - On an annual basis and
    - Prior to the start of practice or competition.
- Removal from Play
  - ✓ Any student athlete or athlete shall be removed from play when they are reasonably suspected of having a concussion by a coach or licensed health care professional.
  - ✓ If an athlete is removed from activity due to reasonable suspicion of suffering a concussion:
    - Parents or Guardians must be notified of the date and approximate time of the injury and the signs and symptoms that were observed, as well as any actions taken to treat.
- Return to Play
  - ✓ A student-athlete or athlete may be allowed to return to play when:
    - They have been evaluated by a licensed health care professional
    - They have received written clearance from the licensed health care professional;
    - They have submitted the written and signed clearance to resume participation in athletic activities accompanied by written permission to resume participation from the student’s parent or guardian.
- For more information, please refer to:
  - ✓ Nebraska Department of Health and Human Services  
<http://dhhs.ne.gov/publichealth/concussion/Pages/Home.aspx>

# CONCUSSION RESOURCES

1. **Nebraska Department of Education**  
<http://www.education.ne.gov/sped/birsst.html>
  - **Bridging the Gap from Concussion to Classroom: Return to Learn**
2. **Nebraska Department of Health and Human Services**  
<http://dhhs.ne.gov/publichealth/concussion/Pages/Home.aspx>
  - Concussion Awareness Act – Training for Coaches, Parents, Students
3. **Concussion ABCs posted by the Centers for Disease Control and Prevention**  
<http://www.cdc.gov/concussion/HeadsUp/schools.html>
  - Heads Up to Schools, Know Your Concussion ABC's
  - A Fact Sheet for Teachers, Counselors, and School Professionals
  - A Fact Sheet for School Nurses
  - Parent/Athlete Concussion Information Sheet
  - Returning to School After a Concussion: A Fact Sheet for School Professionals
4. **The Center on Brain Injury Research and Training, University of Oregon**  
<http://www.cbirt.org>
  - **The Center on Brain Injury Research and Training. *Max's Law: Concussion Management Implementation Guide.*** Retrieved from <http://www.cbirt.org>
  - <http://cbirt.org/tbi-education/school-reentry/returning-school-after-tbi/>
  - <http://cbirt.org/tbi-education/school-reentry/supports-consider-during-school-reentry/>
  - <http://cbirt.org/news/concussion-frequently-asked-questions-parents/>
5. **School-wide Concussion Management cartoon video: "What's a Concussion, Anyway? (15 minute cartoon video)** <http://brain101.orcasinc.com/>
  - Concussion Management Program and information for coaches, schools, parents and students
  - Return to Academics Progression, Return to Play Progression and Sample Return to Activity Documentation

6. REAP Guidelines

<http://www.rockymountainhospitalforchildren.com/sports-medicine/concussion-management/reap-guidelines.htm>

- McAvoy, K. (2013) REAP the benefits of good concussion management. Centennial, CO: Rocky Mountain Sports Medicine Institute Center for Concussion.

7. The BrainSTEPS Program – Pennsylvania [www.brainsteps.net](http://www.brainsteps.net)

- [Concussion Webinar](#)
- [Concussion Return to School Protocol](#)
- [Protocol Flow Chart](#)
- [Why every school should have a Concussion Management Team](#)
- [Teacher's Desk Reference: Concussion](#)

8. Colorado Department of Education

[http://www.cde.state.co.us/sites/default/files/documents/cdesped/download/pdf/tbi\\_concussionguidelines.pdf](http://www.cde.state.co.us/sites/default/files/documents/cdesped/download/pdf/tbi_concussionguidelines.pdf)

- [Concussion Management Guidelines 2012](#)

9. Brain Injury Association of Nebraska [www.biane.org](http://www.biane.org)

10. Halstead, M., McAvoy, K., *et al.* *Returning to Learning Following a Concussion. Pediatrics*: originally published online October 27, 2013.  
<http://pediatrics.aappublications.org/content/early/2013/10/23/peds.2013-2867>

11. Nebraska Brain Injury Advisory Council [www.braininjury.ne.gov](http://www.braininjury.ne.gov)

12. brainline.org - <http://www.brainline.org/content/2010/06/general-information-for-parents-educators-on-tbi.html>

13. Information for Parents

[http://www.brainline.org/landing\\_pages/categories/concussion.html](http://www.brainline.org/landing_pages/categories/concussion.html)  
<http://cbirt.org/news/concussion-frequently-asked-questions-parents/>

## RETURN TO ACADEMICS PROGRESSION

Progression is individual. All concussions are different. Students may start at any of these steps, depending on symptoms, and may remain at a step longer if needed. If symptoms worsen, the CMT should reassess. If symptoms quickly improve, a student may also skip a step or two. Be flexible!

Steps	Progression	Description
1	<b>HOME – Cognitive and physical rest</b>	<ul style="list-style-type: none"> <li>➤ Stay at home</li> <li>➤ No driving</li> <li>➤ Limited mental exertion – computer, texting, video games, homework</li> </ul>
2	<b>HOME – Light Mental Activity</b>	<ul style="list-style-type: none"> <li>➤ Stay at home</li> <li>➤ No driving</li> <li>➤ Up to 30 minutes mental exertion</li> <li>➤ No prolonged concentration</li> </ul>

**Progress to Step 3 when student handles up to 30 minutes of sustained mental exertion without worsening of symptoms.**

3	<b>SCHOOL – Part Time</b>  Maximum adjustments  Shortened day/schedule  Built-in breaks	<ul style="list-style-type: none"> <li>➤ Provide quiet place for scheduled mental rest</li> <li>➤ Lunch in quiet environment</li> <li>➤ No significant classroom or standardized testing</li> <li>➤ Modify rather than postpone academics</li> <li>➤ Provide extra time, help, and adjustment of assignments</li> </ul>
---	-----------------------------------------------------------------------------------------------------------	-------------------------------------------------------------------------------------------------------------------------------------------------------------------------------------------------------------------------------------------------------------------------------------------------------------------------

**Progress to Step 4 when student handles 30-40 minutes of sustained mental exertion without worsening of symptoms.**

4	<b>SCHOOL – Part Time</b>  Maximum adjustments  Shortened day/schedule	<ul style="list-style-type: none"> <li>➤ No standardized testing</li> <li>➤ Modified classroom testing</li> <li>➤ Moderate decrease of extra time, help, and modification of assignments</li> </ul>
---	------------------------------------------------------------------------------------	-----------------------------------------------------------------------------------------------------------------------------------------------------------------------------------------------------

**Progress to Step 5 when student handles 60 minutes of mental exertion without worsening of symptoms.**

5	<b>SCHOOL – Part Time</b>  Minimal adjustments	<ul style="list-style-type: none"> <li>➤ No standardized testing; routine tests are OK</li> <li>➤ Continued decrease of extra time, help, and adjustment of assignments</li> <li>➤ May require more support in academically challenging subjects</li> </ul>
---	------------------------------------------------------	-------------------------------------------------------------------------------------------------------------------------------------------------------------------------------------------------------------------------------------------------------------

**Progress to Step 6 when student handles all class periods in succession without worsening of symptoms AND receives medical clearance for full return to academics and athletics.**

6	<b>SCHOOL – Full Time</b>  Full academics  No adjustments	<ul style="list-style-type: none"> <li>➤ Attends all classes</li> <li>➤ Full homework and testing</li> </ul>
---	-----------------------------------------------------------------------	--------------------------------------------------------------------------------------------------------------

**When symptoms continue beyond 3-4 weeks, prolonged in-school supports are required. Request a 504 meeting to plan and coordinate student supports.**

© 2013 ORCAS [www.orcasinc.com](http://www.orcasinc.com) Adapted with permission from Oregon Concussion and Management Program (OCAMP) and Slocum Sports Concussion Program

## RETURN TO PLAY PROGRESSION

Return to play is a medical decision. The CMT will be familiar with state concussion laws and understand which healthcare providers may clear a student. **To begin the Return to Play Plan, the student must be free of all symptoms (see Signs and Symptoms of Concussion), have no academic adjustments in place, and be cleared by a healthcare provider.** The student may spend 1-2 days at each step before advancing to the next. If post-concussion symptoms occur at any step, stop activity and have the CMT reassess.

Rehabilitation Stage	Functional exercise at each stage of rehabilitation	Objective of each stage
1. No activity	Symptom limited physical and cognitive rest.	Recovery
2. Light aerobic exercise	Walking, swimming or stationary cycling keeping intensity <70% maximum permitted heart rate.  No resistance training.	Increase HR
3. Sport-specific exercise	Skating drills in ice hockey, running drills in soccer. No head impact activities.	Add movement
4. Non-contact training drills	Progression to more complex training drills, e.g., passing drills in football and ice hockey. May start progressive resistance training.	Exercise, coordination and cognitive load
5. Full-contact Practice	Following medical clearance.  Participate in normal training activities.	Restore confidence and assess functional skills by coaching staff
6. Return to play	Normal game play	

Recommendations from 2012 Zurich Consensus Statement on Concussion – McRory, P., Meeuwisse, WH, Aubry, M, et. al., *Br. J Sports Med* 2013; 47:250-258.

# Post-Concussion Symptom Checklist

Name: \_\_\_\_\_

Date: \_\_\_\_\_

Please indicate how much each symptom has bothered you over the past 2 days.

	Symptoms	None	Mild		Moderate		Severe	
PHYSICAL	Headache	0	1	2	3	4	5	6
	Nausea	0	1	2	3	4	5	6
	Vomiting	0	1	2	3	4	5	6
	Balance Problem	0	1	2	3	4	5	6
	Dizziness	0	1	2	3	4	5	6
	Blurry or double vision	0	1	2	3	4	5	6
	Sensitivity to Light	0	1	2	3	4	5	6
	Sensitivity to Noise	0	1	2	3	4	5	6
	Balance Problems	0	1	2	3	4	5	6
	Pain other than headache	0	1	2	3	4	5	6
THINKING/ COGNITIVE	Feeling "in a fog"	0	1	2	3	4	5	6
	Feeling Slowed Down	0	1	2	3	4	5	6
	Difficulty concentrating	0	1	2	3	4	5	6
	Difficulty Remembering	0	1	2	3	4	5	6
SLEEP ISSUES	Trouble Falling Asleep	0	1	2	3	4	5	6
	Fatigue or low energy	0	1	2	3	4	5	6
	Drowsiness	0	1	2	3	4	5	6
EMOTIONAL	Feeling more Emotional	0	1	2	3	4	5	6
	Irritability	0	1	2	3	4	5	6
	Sadness	0	1	2	3	4	5	6
	Nervousness	0	1	2	3	4	5	6

Do symptoms worsen with physical activity? Yes\_\_\_\_\_ No\_\_\_\_\_ Not Applicable\_\_\_\_\_

Do symptoms worsen with thinking/cognitive activity? Yes\_\_\_\_\_ No\_\_\_\_\_ Not Applicable\_\_\_\_\_

Activity Level: Over the past two days, compared to what I would typically do, my level of activity has been \_\_\_\_\_% of what it would normally be.

# TIPS FOR TEACHERS

## Concussion Symptoms, Possible School Problems & Adjustments/Accommodations

Concussion Symptoms	Implications at school	Potential Adjustments in School Setting
<b>PHYSICAL SYMPTOMS</b> <ul style="list-style-type: none"> <li>• <b>Headache (most common symptom reported in concussions)</b></li> </ul>	<ul style="list-style-type: none"> <li>• Poor concentration - may vary throughout day;</li> <li>• Can be triggered by fluorescent lighting, loud noises and focusing on tasks</li> </ul>	<ul style="list-style-type: none"> <li>• Frequent breaks</li> <li>• Reduce exposure to aggravators, i.e., turn off fluorescent lights</li> <li>• Rest as needed in nurse's office or quiet area</li> </ul>
<ul style="list-style-type: none"> <li>• <b>Dizziness/ Lightheadedness</b></li> </ul>	<ul style="list-style-type: none"> <li>• Standing quickly or walking in crowded environment may present a challenge</li> <li>• Often provoked by visual stimulus (rapid movements, videos, etc.)</li> </ul>	<ul style="list-style-type: none"> <li>• Allow student to put head down if symptoms worsen</li> <li>• Early dismissal from class and extra time to get from class to class to avoid crowded hallways</li> </ul>
<ul style="list-style-type: none"> <li>• <b>Visual Symptoms</b> <ul style="list-style-type: none"> <li>○ <b>Light sensitivity</b></li> <li>○ <b>Double vision</b></li> <li>○ <b>Blurry vision</b></li> </ul> </li> </ul>	<ul style="list-style-type: none"> <li>• Trouble seeing slide presentations, movies, smart boards, computers, handheld computers (tablets)</li> <li>• Difficulty reading &amp; copying</li> <li>• Difficulty paying attention to visual tasks</li> </ul>	<ul style="list-style-type: none"> <li>• Reduce brightness on the screens</li> <li>• Student may wear hat or sunglasses in school</li> <li>• Audiotapes instead of books</li> <li>• Seat student close to center of classroom activities (preferential seating if blurry vision)</li> <li>• Turn off fluorescent lights</li> <li>• Cover one eye with patch/ tape or one lens if glasses are worn (double vision)</li> </ul>
<ul style="list-style-type: none"> <li>• <b>Noise Sensitivity</b></li> </ul>	<ul style="list-style-type: none"> <li>• Troubles with various noises in several school settings: Lunchroom, shop classes, music classes (band, choir), physical education classes, hallways</li> <li>• Organized sports practice</li> </ul>	<ul style="list-style-type: none"> <li>• Allow student to eat lunch in quiet area with classmate</li> <li>• Limit or avoid band, choir or shop classes</li> <li>• Avoid noisy gyms and organized sports practices and games</li> <li>• Consider use of earplugs</li> <li>• Early dismissal from class to avoid crowded, noisy hallways</li> </ul>
<b>THINKING/COGNITIVE SYMPTOMS</b> <ul style="list-style-type: none"> <li>• <b>Difficulty concentrating or remembering</b></li> </ul>	<ul style="list-style-type: none"> <li>• Challenges learning new tasks and comprehending new material (slowed processing speed)</li> <li>• Difficulty recalling and applying previously learned material</li> <li>• Lack of focus in the classroom</li> <li>• Difficulties with test taking, including standardized tests</li> </ul>	<ul style="list-style-type: none"> <li>• Avoid testing or completion of major projects during recovery time when possible</li> <li>• Provide extra time to complete non-standardized tests in a quiet environment</li> <li>• Postpone standardized testing when possible</li> <li>• Consider one test per day during exam periods</li> <li>• Assess knowledge using multiple-choice instead of open-ended questions</li> </ul>

<b>Concussion Symptoms</b>	<b>Implications at school</b>	<b>Potential Adjustments in School Setting</b>
<b>THINKING/COGNITIVE SYMPTOMS (cont'd)</b>		<ul style="list-style-type: none"> <li>• Consider use of preprinted notes, note taker, scribe or reader for oral testing</li> <li>• Consider tape recorder for note taking</li> <li>• Reduce the cognitive load &amp; focus on the most important concepts for student to know – quality vs. quantity</li> <li>• Consider decreasing homework and reducing make-up work</li> <li>• Provide both oral and written instructions; clarify instructions</li> </ul>
<b>SLEEP ISSUES</b>	<ul style="list-style-type: none"> <li>• Excessive fatigue can hamper memory for new or past learning or ability to attend and focus</li> <li>• Insufficient sleep can lead to tardiness or excessive absences</li> <li>• Difficulty getting to sleep or frequent waking at night may lead to sleeping in class</li> <li>• Excessive napping due to fatigue may lead to further disruptions of the sleep cycle</li> </ul>	<ul style="list-style-type: none"> <li>• Allow for late start or shortened school day to catch up on sleep</li> <li>• Allow rest breaks during day if needed</li> </ul>
<b>EMOTIONAL/MOOD SYMPTOMS</b>	<ul style="list-style-type: none"> <li>• Sadness, Irritability, changes in mood, nervousness, anxiety may affect social relationships with adults and peers</li> <li>• Student may feel scared, angry or depressed as a result of the concussion.</li> </ul>	<ul style="list-style-type: none"> <li>• Develop an emotional support plan for the student. This may include an adult with whom the student can talk if feeling overwhelmed</li> <li>• Mental fatigue may result in emotional meltdowns</li> <li>• Allow “signal” for student to remove himself/herself from classroom to de-escalate</li> <li>• Provide reassurance that what they are feeling is typical in the course of recovery – i.e., concern about getting behind in school work and/or grades</li> <li>• Share difficulties and progress with parents, CMT contact person, medical personnel, athletic coaches/ trainers as appropriate</li> </ul>

Sources: Halstead, M., McAvoy, K., *et al. Returning to Learning Following a Concussion.*

*Pediatrics*: originally published online October 27, 2013.

<http://pediatrics.aappublications.org/content/early/2013/10/23/peds.2013-2867>

Oregon Concussion Awareness and Management Program (OCAMP)

[http://media.cbirt.org/uploads/files/sports\\_concussion\\_management\\_guide.pdf](http://media.cbirt.org/uploads/files/sports_concussion_management_guide.pdf)

# NE Concussion Management Recommended Best Practices

(Adapted from CDC, OCAMP Advisory group June 2010 and Oregon Concussion Awareness and Management Program)

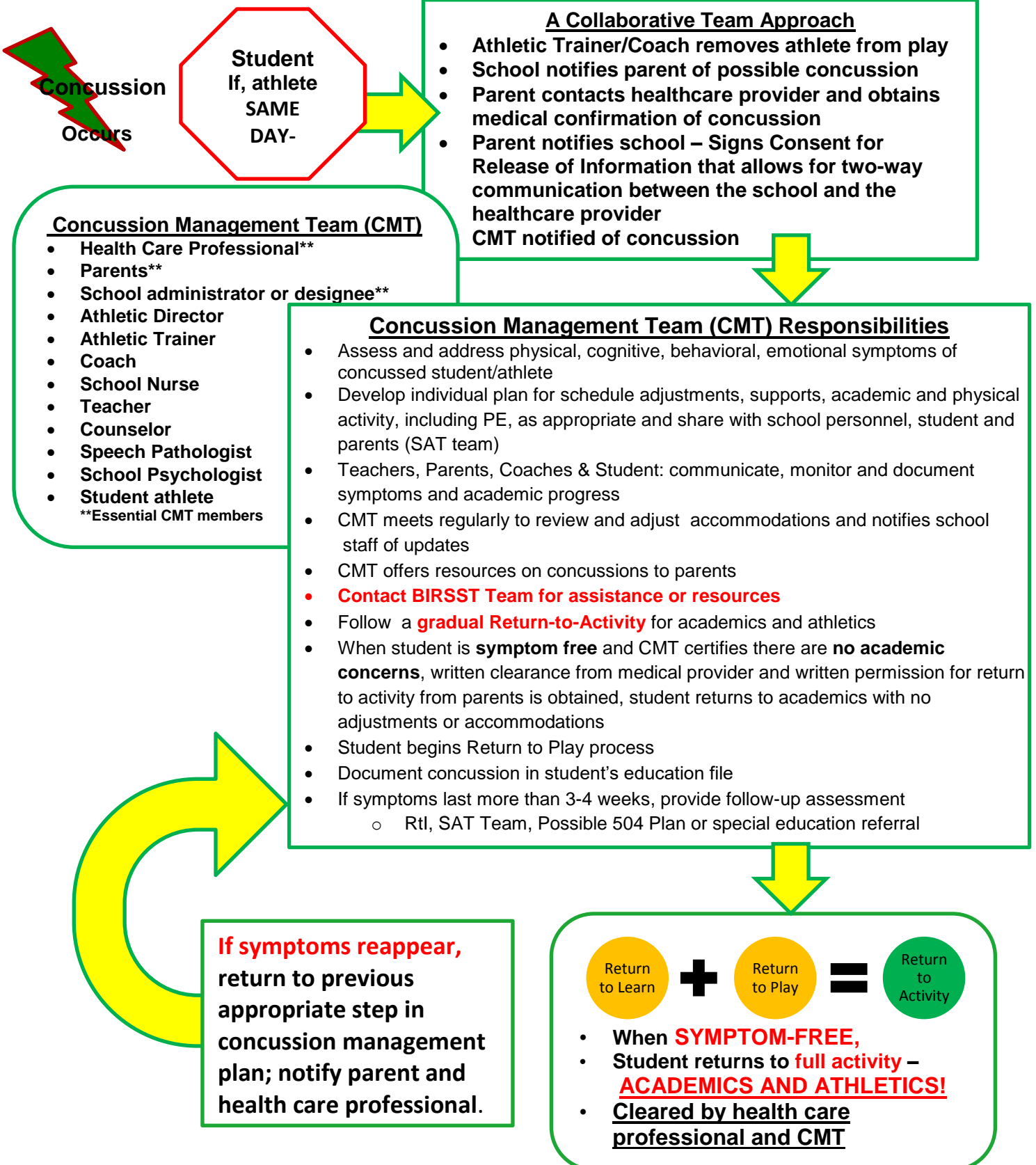

### Information from Teachers for CMT

Date:  Student Name:

Date of Concussion:

**To Teachers:** The above named student has been diagnosed with a concussion. Please indicate if you are seeing physical, cognitive, emotional or sleep/energy symptoms in your classroom related to this concussion, or if you have concerns about this student's progress, please state them below. Thank you for your valuable feedback.

Class: Teacher:	What academic adjustments, if any, is the student still receiving in your classroom?	Has the student reported or have you noticed any concussion symptoms in the last two days? (Headaches, dizziness, difficulty concentrating, remembering, more irritable, fatigued than usual?) If YES, please explain:	Is this student performing at their pre-concussion learning level? Yes or No? If NO, please explain:

A fillable version of this document is available at: <http://www.education.ne.gov/sped/birsst.html>

# BIRSST - Brain Injury School Support Team Contacts 2013-2014

<b>Central Region</b>	<b>Kristine Einspahr</b> ESU #10 76 Plaza Boulevard Kearney, NE 68848	(308) 237-5927 X 314 keinspahr@esu10.org
<b>Metro Region</b>	<b>Greg Gaden</b> ESU #3 6949 S. 10th Omaha, NE 68128  <b>Andrea McDonald</b> ESU #2, #3 and #19  <b>Lou Bauer</b> ESU #2	(402) 597-4934 (402) 610-4240 (cell) ggaden@esu3.org  (402) 350-5622 andrea.mcdonald30@gmail.com  (402) 721-7710 X 209 lbauer@esu2.org
<b>Northeast Region</b>	<b>Cathy Schroeder</b> ESU #1 211 Tenth Street Wakefield, NE 68756	(402) 287-2061 (712) 490-6571 cschroeder@esu1.org
<b>Southeast Region</b>	<b>Cindy Brunken</b> Lincoln Public Schools 5905 O Street Lincoln, NE, 68510	(402) 436-1902 cbrunk@lps.org
<b>Western Region</b>	<b>Steve Helgeland</b> ESU #13 4215 Avenue I Scottsbluff, NE 69361	(308) 635-3696 shelgeland@esu13.org

**BIRSST Region Map – 2013-2014**

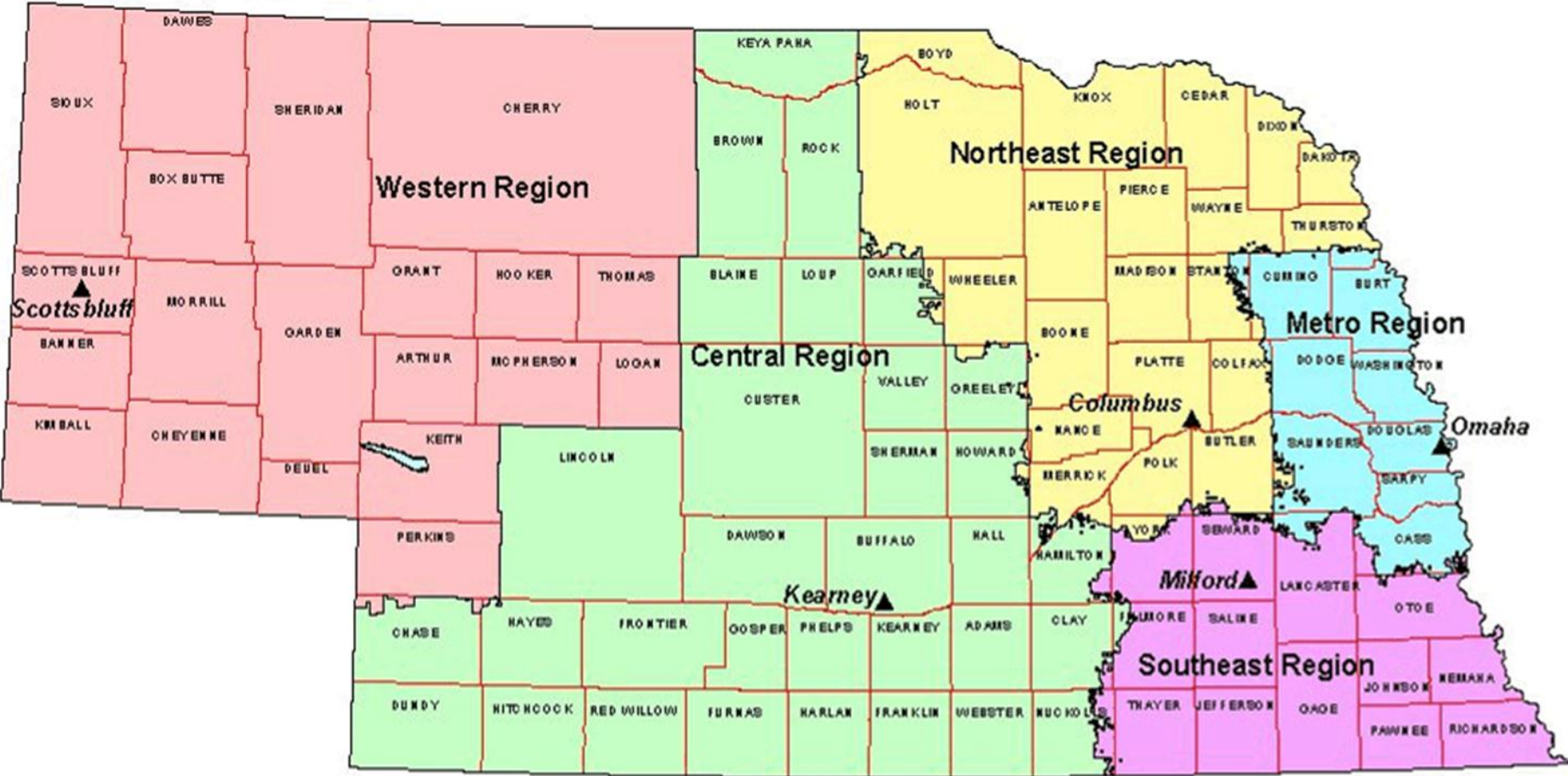

**Student Participation in Athletic Contests Between Schools**

Students in kindergarten through sixth grade may not participate in athletic contests between schools within a school system or between school systems. Annual field or play days are excluded from this restriction.

Sixth grade boys or girls may participate when combined enrollment for seventh and eighth grade becomes fewer than 12 boys or 12 girls or a waiver is otherwise granted. The policy regulating participation for sixth graders is the same as other middle school students.

Elementary school systems having seventh and eighth grade athletics may include sixth grade boys or girls if the combined enrollment for seventh and eighth grade is fewer than 12 boys or 12 girls and if the School Board has a policy regulating participation for sixth graders. The Board's policy for participation of sixth graders is as follows: A sixth grade student may participate if: (1) the student meets the same standards applicable to seventh and eighth graders and (2) participation in the activity is not prohibited by the bylaws of the Nebraska School Activities Association.

Students in seventh and eighth grades may participate in interscholastic competitions subject to and in a manner consistent with the bylaws of the Nebraska School Activities Association. The scholastic eligibility rules for seventh and eighth grades shall be the same as established by the School Board for high school interscholastic competitions and, in the absence of such rules, shall be the minimum established by the Nebraska School ~~Activities Athletics~~ Association.

Legal Reference: NDE Rule 10.004.02C  
Nebraska School Activities Association Middle Level Activities Bylaws, Article 9

Date of Adoption: May 19, 2014

InstructionPlagiarism, Copyrights and PatentsPlagiarism

Plagiarism by staff or students is considered academic dishonesty, is prohibited, and may result in disciplinary action, including termination from employment or expulsion from school.

Plagiarism is the use or close imitation of the work, language or ideas of another and the representation of them as one's own original work. All staff shall be responsible for informing themselves and reviewing relevant information pertaining to plagiarism. Teachers will instruct students in appropriate research and citation practices.

Copyrights and Patents

It is the intent of the District to adhere to the provisions of the U.S. Copyright Law and the Patent Act. All individuals within the District, including administrators, teachers, other staff members, and students, are prohibited from using, copying or transmitting materials not specifically allowed by fair use, copyright or patent law, licenses or contractual agreements or permission. All staff shall be responsible for informing themselves and reviewing relevant information pertaining to copyright and patent rules, fair use, District licenses or contractual agreements and permissions. Individuals within the District who are uncertain as to whether a material is copyrighted must seek prior clarification from a supervisor or administrator before copying or transmitting such materials.

Anyone who disregards this copyright and patent policy is in violation of the law and this policy, assumes all responsibility for infringement, including possible civil liability and criminal prosecution and may be subject to disciplinary action including termination from employment. The District does not assume any legal responsibility for any infringement of copyrights, patents, or other proprietary rights.

All staff shall also respect the copyright, patent and proprietary rights of any materials accessed through the District's network system or technology resources. Staff may not use or duplicate copyrighted or patented materials, graphics, software (including District-owned or –licensed software) or other proprietary materials without permission from the copyright or patent holder, unless the use falls within fair use parameters, licenses or contractual agreements or permissions, whether for personal use or for the use of others.

Persons who secure permission, licenses or other contractual agreements shall maintain adequate records regarding the use of copyrighted or patented materials.

Legal Reference: 17 U.S.C. § 101

Date of Adoption: [Insert Date]

## Artificial Intelligence

### Introduction

Raymond Central Public Schools acknowledges that artificial intelligence continues to emerge as a resource that may assist students with future technology and different ways of learning. However, artificial intelligence also poses a challenge to delineate the responsible use of artificial intelligence with student plagiarism. As a result, the Board of Education adopts this Policy to specifically address how the District will address academic honesty and integrity regarding a student's use of artificial intelligence/

### Permissible Uses of Artificial Intelligence in School Assignments

Students may use artificial intelligence or related platforms when any of the following occurs:

1. The student receives advance permission from the teacher for the given assignment or project; or
2. The teacher's classroom rules or expectations established artificial intelligence as a permissible resource for students to access.

Any student with questions about the use of artificial intelligence should contact their teacher in advance of using artificial intelligence to assist with any assignment. It is the responsibility of each student to understand the permissible use (if any) of artificial intelligence in a given class or a particular assignment. Students must be fully forthright and honest about their use of artificial intelligence to assist with any school assignment.

### Impermissible Uses of Artificial Intelligence in School Assignments

Unless otherwise permitted by this Policy, students may not use artificial intelligence or related platforms to assist or complete any assignment, project, test, or other school-related task. The impermissible use of artificial intelligence may subject the student to discipline in accordance with the District's plagiarism policy and academic dishonesty rules.

Date of Adoption: [Insert Date]

**Dedications and Commencement**

Traditions are a cherished part of community life and Raymond Central Public Schools expresses an interest in maintaining those traditions which have a significance to the community. The graduation ceremony is considered an extracurricular activity and participation in it is a privilege.

Date of Adoption: May 18, 2009

**Parent Requests for Exclusion**

Parents may request that their child be excused from the study of a given book, instructional unit or particular literary work. The Superintendent or designee ~~Principal~~ shall determine whether to grant such requests based on legal requirements relating to the request, the reason given for the request, the effect of the request on the student's educational development and the educational program, and the availability of alternative materials or instruction for the student. The Superintendent or designee's decision shall be final and not subject to appeal. The Superintendent or designee may develop and implement forms consistent with this policy. In the event the Principal does not grant the request, the parent may request a review be conducted by the Superintendent, based on the same criteria.

Date of Adoption: May 18, 2009

**Acknowledgment of Religious Holidays**

The practice of the Raymond Central Public School District shall be as follows:

1. The several holidays throughout the year which have a religious and a secular basis may be observed or recognized in the public schools.
2. The historical and contemporary values and the origin of religious holidays may be explained in an unbiased and objective manner without sectarian indoctrination.
3. Music, art, literature and drama having religious themes or bases are permitted as part of the curriculum for school sponsored activities and programs if presented in a prudent and objective manner and as a traditional part of the cultural and religious heritage of the particular holiday.
4. The use of religious symbols such as a cross, menorah, crescent, Star of David, creche, symbols of Native American religions or other symbols that are a part of a religious holiday is permitted as a teaching aid or resource provided such symbols are displayed as an example of the cultural and religious heritage of the holiday and are temporary in nature. Among these holidays included are Christmas, Easter, Passover, Hanukkah, ~~St. Valentine's Day, St. Patrick's Day, Ramadan,~~ Thanksgiving and Halloween.

Date of Adoption: May 18, 2009

**Religion in the Curriculum**

Religious institutions and orientations are central to human experience, past and present. An education excluding such a significant aspect would be incomplete. It is essential that the teaching about -- and not of -- religion be conducted in a factual objective and respectful manner. **However, sectarian instruction of any kind is prohibited in this school.**

Date of Adoption: May 18, 2009

**Controversial Issues in the Classroom**

The following administrative and teaching regulations are to be observed:

**For Principals:**

1. Remind teachers that we do not teach controversial issues, but rather opportunities for their study.

**For Teachers:**

1. Deal with controversial topics as impartially and objectively as possible. Do not intrude your own biases.
2. Handle all such topics in a manner suited to the range of knowledge, maturity, and competence of your students.
3. Have teaching materials dealing with all possible aspects of the topics readily available.
4. Do not manufacture an issue. Take up only those that are current and real.
5. Do not expect or require that **individual students or** the class reach an agreement.
6. **If you plan to address a controversial topic in your classroom, notify your Principal in advance. Similarly, if a controversial topic or discussion arises during instructional time, promptly notify your Principal. Students or parents who are upset about a controversial topic may contact the Principal, and the Principal needs to be prepared to have that conversation with parents.**
7. Whenever you are in doubt about the advisability of taking up a given "hot" topic, consult with your Principal and or/Superintendent.
8. Remember that the policy of the board is designed to protect you as well as your students from unfair or inconsiderate criticism whenever your students are studying a controversial subject.

Date of Adoption: May 18, 2009

**Parental/Community Involvement in Schools**

Lancaster County School District No. 55-0161 a/k/a Raymond Central Public Schools, after having conducted a public hearing concerning parental involvement and participation, declares that it shall be the policy of the District:

1. In the event any parent has a complaint or objection to textbooks, tests, curriculum materials, and any other instructional materials, the parent may request a personal conference with the parent and appropriate school personnel to discuss such concerns as the superintendent or designee may deem appropriate. The Superintendent or designee shall prepare a complaint form which may be used by a parent to express objections to any such instructional material. Such complaint forms shall seek information including, but not limited to, the specific instructional material complained of, the reason for the complaint, and a proposed resolution of the complaint by the parent.
2. Upon reasonable advance request a parent will be permitted to attend and monitor courses, assemblies, counseling sessions, and other instructional activities unless the school determines that such attendance would substantially interfere with a legitimate school interest, which includes the interests of the parent's child, other students, and the educational staff.
3. Parents are encouraged to communicate to school staff when the parent believes it to be appropriate for their child to be excused from testing, classroom instruction, and other school experiences that the parent finds objectionable. The Superintendent or designee shall make a provision on the complaint form hereinabove referenced for receiving information from a parent concerning what specific testing, classroom instruction, or other school experience the parent finds objectionable, the basis for the parent's objection and a proposed solution for dealing with the objection that would be satisfactory to the parent and consistent with the mission of the District and legitimate school interests.
4. Upon request of a parent, the District will provide access to the education records of their child consistent with applicable law. Access will be provided during regular business hours of the school.
5. The District will notify parents when their child may be subjected to a standard norm referenced or criterion referenced test or standard tests. **such as but not limited to the Measure of Academic Progress (MAP) test or Iowa Test of Basic Skills or the California Achievement Test.** When reasonable to do so or required by law the parents will be notified of where a sample of such a test might be observed and the date upon which such test will be administered. As to all testing by the District, experimental evaluation methodologies, experimental testing instruments and any testing instrument which would tend to inquire into the values, beliefs, or privacy rights of any student, or parent or guardian of such student shall be prohibited unless a parent requests in writing that such tests be administered to their child.
6. Prior to any school sponsored survey being administered to the students of the District, it shall be the responsibility of the Superintendent or designee to notify the parent or parents of each student involved in the survey of the nature of the survey, the date and time when such survey shall be administered, and the purpose for which and the uses of which survey exist from the school's perspective.
7. As a general matter substantive decision-making processes will be left to the judgment of the professional staff, administration and the Board of Education, subject to an effort to receive information from parents as to any concerns, objections, or other information such parents would wish to provide to the school district concerning a parent's access, involvement, and participation in activities of the school.

Legal Reference: Neb. Rev. Stat. §§ 79-530 to 79-533  
Family Educational Rights and Privacy Act, 20 U.S.C. 1232g  
Protection of Pupil Rights Amendment, 20 U.S.C. 1232h

Date of Adoption: May 18, 2009  
Date of Revision: June 14, 2021  
Reviewed with No Changes: July 12, 2023

**Complaint or Objection Form**

This complaint form may be used by a parent or legal guardian to express objections to any such curriculum/instructional material. Such complaint forms shall seek information including, but not limited to, the specific curriculum/instructional material complained of, the reason for the complaint, and a proposed resolution of the complaint by the parent.

Parent/Guardian: \_\_\_\_\_ Phone: \_\_\_\_\_

Address: \_\_\_\_\_

Curriculum/Instructional Material Complained of: \_\_\_\_\_

\_\_\_\_\_  
\_\_\_\_\_  
\_\_\_\_\_

Reason for Complaint:

\_\_\_\_\_  
\_\_\_\_\_  
\_\_\_\_\_

Proposed Resolution:

\_\_\_\_\_  
\_\_\_\_\_  
\_\_\_\_\_

\_\_\_\_\_  
Signature of Parent/Guardian

\_\_\_\_\_  
Date

Date of Adoption: August 16, 2010  
Date of Revision: June 4, 2018

**Computer/Internet Safety and Acceptable Use Policy****A. Internet Safety Policy**

It is the policy of Raymond Central Public Schools to comply with the Children's Internet Protection Act (CIPA) and Children's Online Privacy Protection Act (COPPA). With respect to the District's computer network, the District shall: (a) prevent user access to, or transmission of, inappropriate material via Internet, electronic mail, or other forms of direct electronic communications; (b) provide for the safety and security of minors when using electronic mail, chat rooms, and other forms of direct electronic communications; (c) prevent unauthorized access, including so-called "hacking," and other unlawful activities online; (d) prevent unauthorized online disclosure, use, or dissemination of personal identification information of minors; (e) obtain verifiable parental consent before allowing third parties to collect personal information online from students; and (f) implement measures designed to restrict minors' access to materials (visual or non-visual) that are harmful to minors.

1. **Definitions.** Key terms are as defined in CIPA. "Inappropriate material" for purposes of this policy includes material that is obscene, child pornography, or harmful to minors. The term "harmful to minors" means any picture, image, graphic image file, or other visual depiction that: (1) taken as a whole and with respect to minors, appeals to a prurient interest in nudity, sex, or excretion; (2) depicts, describes, or represents, in a patently offensive way with respect to what is suitable for minors, an actual or simulated sexual act or sexual contact, actual or simulated normal or perverted sexual acts, or a lewd exhibition of the genitals; and (3) taken as a whole, lacks serious literary, artistic, political, or scientific value as to minors.
2. **Access to Inappropriate Material.** To the extent practical, technology protection measures (or "Internet filters") shall be used to block or filter Internet, or other forms of electronic communications, access to inappropriate information. Specifically, as required by the CIPA, blocking shall be applied to visual depictions of material deemed obscene or child pornography, or to any material deemed harmful to minors. Subject to staff supervision, technology protection measures may be disabled or, in the case of minors, minimized only for bona fide research or other lawful purposes.
3. **Inappropriate Network Usage.** To the extent practical, steps shall be taken to promote the safety and security of users of the District's online computer network when using electronic mail, chat rooms, instant messaging, and other forms of direct electronic communications. Specifically, as required by CIPA, prevention of inappropriate network usage includes: (a) unauthorized access, including so-called 'hacking,' and other unlawful activities; and (b) unauthorized disclosure, use, and dissemination of personal identification information regarding minors.
4. **Supervision and Monitoring.** It shall be the responsibility of all members of the District staff to supervise and monitor usage of the online computer network and access to the Internet in accordance with this policy and CIPA. Procedures for the disabling or otherwise modifying any technology protection measures shall be the responsibility of the Superintendent and the Superintendent's designees.
5. **Social Networking.** Students shall be educated about appropriate online behavior, including interacting with others on social networking websites and in chat rooms, and cyberbullying awareness and response. The plan shall be for all students to be provided education on these subjects. The Superintendent or the Superintendent's designee shall be responsible for identifying educational materials, lessons, and/or programs suitable for the age and maturity level of the students and for ensuring the delivery of such materials, lessons, and/or programs to students.

6. Parental Consent. The District shall obtain verifiable parental consent prior to students providing or otherwise disclosing personal information online.
7. Adoption. This Internet Safety Policy was adopted by the Board at a public meeting, following normal public notice.
8. The District shall comply with the Nebraska Student Online Personal Protection Act and will endeavor to take all reasonable and necessary steps to protect the online privacy of all students.

B. Computer Acceptable Use Policy

This computer acceptable use policy is supplemental to the District's Internet Safety Policy.

1. Technology Subject to this Policy. This Computer Acceptable Use Policy applies to all technology resources of the District or made available by the District. Technology resources include, without limitation, computers and related technology equipment, all forms of e-mail and electronic communications, and the internet.
2. Access and User Agreements. Use of the District technology resources is a privilege and not a right. The Superintendent or designee shall develop appropriate user agreements and shall require that employees, students (and their parents or guardians), and others to sign such user agreements as a condition of access to the technology resources, as the Superintendent determines appropriate. Parents and guardians of students in programs operated by the District shall inform the Superintendent or designee in writing if they do not want their child to have access.

The Superintendent and designees are authorized and directed to establish and implement such other regulations, forms, procedures, guidelines, and standards to implement this Policy.

The technology resources are not a public forum. The District reserves the right to restrict any communications and to remove communications that have been posted.

3. Acceptable Uses. The technology resources are to be used for the limited purpose of advancing the District's mission. The technology resources are to be used, in general, for educational purposes, meaning activities that are integral, immediate, and proximate to the education of students as defined in the E-rate program regulations.
4. Unacceptable Uses.

The following are unacceptable uses of the technology resources:

- a) Personal Gain: Technology resources shall not be used, and no person shall authorize its use, for personal financial gain other than in accordance with prescribed constitutional, statutory, and regulatory procedures, other than compensation provided by law.
- b) Personal Matters: Technology resources shall not be used, and no person shall authorize its use, for personal matters unless the User has entered into a lease agreement or other similar agreement with the School District that makes such use permissible under law.

Occasional use that the Superintendent or designee determines to ultimately facilitate the mission of the District is not prohibited by this provision. Examples of occasional use that may be determined to ultimately facilitate the mission of the District: sending an email to a minor

child or spouse; sending an email related to a community group in which an employee is a member where the membership in the community group facilitates the District's mission.

This occasional use exception does not permit use by employees contrary to the expectations of their position. For example, employees may not play games or surf the net for purposes not directly related to their job during duty time; nor may students do so during instructional time.

The occasional use exception also does not permit use of the technology resources for private business, such as searching for or ordering items on the internet for non-school use; or sending an e-mail related to one's own private consulting business.

- c) Campaigning: Technology resources shall not be used, and no person shall authorize its use, for the purpose of campaigning for or against the nomination or election of a candidate or the qualification, passage, or defeat of a ballot question.
- d) Technology-Related Limitations: Technology resources shall not be used in any manner which impairs its effective operations or the rights of other technology users. Without limitation:
  - 1) Users shall not use another person's name, log-on, password, or files for any reason, or allow another to use their password (except for authorized staff members).
  - 2). Users shall not erase, remake, or make unusable another person's computer, information, files, programs or disks.
  - 3). Users shall not access resources not specifically granted to the user or engage in electronic trespassing.
  - 4). Users shall not engage in "hacking" to gain unauthorized access to the operating system software or unauthorized access to the system of other users.
  - 5) Users shall not copy, change, or transfer any software without permission from the network administrators.
  - 6) Users shall not write, produce, generate, copy, propagate, or attempt to introduce any computer code designed to self-replicate, damage, or otherwise hinder the performance of any computer's memory, file system, or software. Such software is often called a bug, virus, worm, Trojan horse, or similar name.
  - 7) Users shall not engage in any form of vandalism of the technology resources.
  - 8) Users shall follow the generally accepted rules of network etiquette. The Superintendent or designees may further define such rules.
- e) Other Policies and Laws: Technology resources shall not be used for any purpose contrary to any District policy, any school rules to which a student user is subject, or any applicable law. Without limitation, this means that technology resources may not be used:
  - 1) to access any material contrary to the Internet Safety Policy; or to create or generate any such material.
  - 2) to engage in unlawful harassment or discrimination, such as sending emails that contain sexual jokes or images.
  - 3) to engage in violations of employee ethical standards and employee standards of performance, such as sending emails that are threatening or offensive or which contain abusive language; use of end messages on emails that may imply that the District is supportive of a particular religion or religious belief system, a political candidate or issue, or a controversial issue; or sending emails that divulge protected confidential student information to unauthorized persons.
  - 4) to engage in or promote violations of student conduct rules.
  - 5) to engage in illegal activity, such as gambling.
  - 6) in a manner contrary to copyright laws.
  - 7) in a manner contrary to software licenses.

5. Disclaimer. The technology resources are supplied on an “as is, as available” basis. The District does not imply or expressly warrant that any information accessed will be valuable or fit for a particular purpose or that the system will operate error free. The District is not responsible for the integrity of information accessed, or software downloaded from the Internet.
6. Filter. A technology protection measure is in place that blocks and/or filters access to prevent access to Internet sites that are not in accordance with policies and regulations. In addition to blocks and/or filters, the District may also use other technology protection measures or procedures as deemed appropriate.

Notwithstanding technology protection measures, some inappropriate material may be accessible by the Internet, including material that is illegal, defamatory, inaccurate, or potentially offensive to some people. Users accept the risk of access to such material and responsibility for promptly exiting any such material.

The technology protection measure that blocks and/or filters Internet access may be disabled only by an authorized staff member for bona fide research or educational purposes: (a) who has successfully completed District training on proper disabling circumstances and procedures, (b) with permission of the immediate supervisor of the staff member requesting said disabling, or (c) with the permission of the Superintendent. An authorized staff member may override the technology protection measure that blocks and/or filters Internet access for a minor to access a site for bona fide research or other lawful purposes provided the minor is monitored directly by an authorized staff member.

7. Monitoring. Use of the technology resources, including but not limited to internet sites visited and e-mail transmitted or received, is subject to monitoring by the administration and network administrators at any time to maintain the system and insure that users are using the system responsibly, without notice to the users. Users have no privacy rights or expectations of privacy with regard to use of the District’s computers or Internet system. All technology equipment shall be used under the supervision of the Superintendent and the Superintendent’s designees.
8. Sanctions. Violation of the policies and procedures concerning the use of the District technology resources may result in suspension or cancellation of the privilege to use the technology resources and disciplinary action, up to and including expulsion of students and termination of employees. Use that is unethical may be reported to the Commissioner of Education. Use that is unlawful may be reported to the law enforcement authorities. Users shall be responsible for damages caused and injuries sustained by improper or non-permitted use.

Legal Reference: Children’s Internet Protection Act, 47 USC § 254; Children’s Online Privacy Protection Act, 15 U.S.C. § 6501; FCC Order adopted August 10, 2011; 47 USC § 254(h)(1)(b); 47 CFR 54.500(b) and 68 FR 36932 (2003) (E-rate restrictions); Neb. Rev. Stat. § 49-14,101.01 (Political Accountability and Disclosure Act); **LB 512 (2017)**.

Date of Adoption: May 18, 2009

Date of Revision: June 14, 2017

**Raymond Central Public Schools  
Addition to Employee Code of Conduct  
*Appendix "1"***

**ACCEPTABLE USE OF COMPUTERS AND NETWORKS**

**ADMINISTRATORS, FACULTY AND STAFF AGREEMENT**

In order to make sure that all members of Raymond Central Public Schools community understand and agree to these rules of conduct for use of the e-mail and Internet systems of the school district, the Raymond Central Public School District asks that you, as an administrator, faculty member, or staff member user, sign the following statement:

I have received a copy of, and have read, the Internet Safety and Acceptable Use Policy adopted by the Raymond Central Public Schools, and I understand and will abide by those district guidelines and conditions for the use of the facilities of Raymond Central Public Schools and access to the Internet. I further understand that any violation of the district guidelines is unethical and may constitute a criminal offense. Should I commit any violation, my access privileges will be revoked. School disciplinary action and/or appropriate legal action will be taken.

I agree not to hold the Raymond Central Public Schools, any of its employees, or any institution providing network access to Raymond Central Public Schools responsible for the performance of the system or the content of any material accessed through it.

Employee's Name

Employee's Signature \_\_\_\_\_ Date

This form will be retained on file by authorized faculty designee for duration of applicable computer/network/Internet use.

**Raymond Central Public Schools  
Addition to Student Code of Conduct  
*Appendix "2"***

**ACCEPTABLE USE OF COMPUTERS AND NETWORKS**

**STUDENT'S AGREEMENT**

In order to make sure that all members of Raymond Central Public Schools community understand and agree to these rules of conduct, Raymond Central Public Schools asks that you as a student user sign the following statement:

I have received a copy of, and have read, the Internet Safety and Acceptable Use Policy adopted by the Raymond Central Public Schools, and I understand and will abide by those district guidelines and conditions for the use of the facilities of Raymond Central Public Schools and access to the Internet. I further understand that any violation of the district guidelines is unethical and may constitute a criminal offense. Should I commit any violation, my access privileges will be revoked. School disciplinary action and/or appropriate legal action will be taken.

I agree not to hold the Raymond Central Public Schools, any of its employees, or any institution providing network access to Raymond Central Public Schools responsible for the performance of the system or the content of any material accessed through it.

Student's Name \_\_\_\_\_

Student's Signature \_\_\_\_\_ Date

This form will be retained on file by authorized faculty designee for duration of applicable computer/network/Internet use.

**Raymond Central Public Schools  
Addition to Student Code of Conduct  
*Appendix "3"***

**ACCEPTABLE USE OF COMPUTERS AND NETWORKS**

**PARENT'S AGREEMENT**

In order to make sure that all members of Raymond Central Public Schools community understand and agree to these rules of conduct, we ask that you as a parent/guardian sign the following statement:

I have received a copy of, and have read, the Internet Safety and Acceptable Use Policy adopted by Raymond Central Public Schools. As parent or guardian of the student named below, I grant permission for my son or daughter to access networked computer services such as electronic mail (e-mail) and the Internet. I understand that this free access is designed for educational purposes. I also understand that individuals may be held liable for violations of those Terms and Conditions. However, I also recognize that it is impossible to restrict access to all controversial materials and I will not hold Raymond Central Public Schools responsible for materials acquired or sent via the network.

I agree not to hold the Raymond Central Public Schools, any of its employees, or any institution providing network access to Raymond Central Public Schools responsible for the performance of the system or the content of any material accessed through it.

Student's Name

Parent's Signature \_\_\_\_\_ Date

This form will be retained on file by authorized faculty designee for duration of applicable computer/network/Internet use.

### **Dispensing Medications**

The administration of medication at school is strongly discouraged except when necessary for the student's health or education. The dosage intervals of many medications can be adjusted so the times for taking the medication come outside school hours. When possible, interval adjustment should be considered before administering medication at school. All medications administered by school district personnel shall be administered in accordance with the Medication Aide Act.

- A. Authorizations for Prescription Medications. Prescription medications which must be administered during school hours may be administered when the following are on file at school:
1. Physician's Authorization: A physician's signed, dated authorization including name of the medication, dosage, administration route, time to be given at school, and reason child is receiving the medication.
  2. Caretaker's Authorization: A caretaker's signed and dated authorization or permission to administer the medication during school. (Note: All references to "caretaker" in this policy shall mean a parent, foster parent, family member, or legal guardian who provides care for the student for whom medication is to be administered. The laws include a "friend" as a caretaker, but the school will not ordinarily recognize such an individual as a "caretaker" for the purposes of medication administration).
  3. Original Packaging: The medication is in its original packaging and is labeled as dispensed by the prescriber or pharmacist. The label must name the child and identify the medication, strength, time interval and route to be administered. Two labeled containers may be requested: one for home and one for school. If needed, the physician may be contacted for clarification on medication administration.
- B. Authorizations for Non-Prescription Medications. If a student must take non-prescription medication during school, procedures 2 and 3 above are to be followed before administration.
- C. Renewal of Authorizations. Medication authorizations must be renewed annually and updated immediately as changes occur.
- D. Documentation of Administration of Medication. The school district shall keep and maintain accurate medication administration records. A record of each dose of medication administered shall be documented reflecting the student's name, and the name of the medication, date, time, dosage, route, the signature and title of the person administering the medication and any unusual observations, and any refusal by the recipient to take and/or receive the medication. Medication documentation shall be kept confidential in accordance with the policies and practices concerning student records, provided that medication administration records shall be available to the Department of Education and the Department of Health and Human Services Regulation and Licensure for inspection and copying according to the Family Education Rights and Privacy Act (FERPA) requirements. Such medication administration records shall be maintained for not less than two (2) years.
- E. Storage of Medications. Medication shall be stored in a locked or otherwise secure area in accordance with the manufacturer's or dispensing pharmacist's instructions or temperature, light, humidity, or other storage instructions. Only authorized school personnel who are designated by the administration of the school district for administration of medications shall have access to the medications. The school nurse shall establish procedures for monitoring the storage and handling of medication, the medication's expiration date, and the disposal of medication.

- F. Receipt and Disposal of Medications. Medication shall be delivered to school personnel and picked up by the parent. When medication is received, the amount received should be documented. Medication which is either past the expiration date or not claimed by the parent by the end of the school year shall be destroyed. Procedures for destroying medication shall include witness and documentation.
- G. Administration of Medication by School Personnel.
1. Administration of Medication: Administration of medication includes, but is not limited to:
    - a. Providing medications for another person according to the “five rights” (getting the right drug to the right recipient in the right dosage by the right route at the right time);
    - b. Recording medication provision; and
    - c. Observing, monitoring, reporting, and otherwise taking appropriate actions regarding desired effects, side effects, interactions, and contraindications associated with the medication.
  2. Authorized School Personnel: Administration of medication shall only be done by the following school personnel:
    - a. Health Care Professionals (School Nurses). This means an individual who holds a current license from the Department of Health and Human Services Regulation and Licensure for whom administration of medication is included in the scope of practice. For purposes of this Policy, such individuals are referred to as “school nurses.”
    - b. Medication Competent Staff. This means a staff member of the school who has been determined to be competent to administer medication by: (i) a recipient with capability and capacity to make an informed decision about medications (at a minimum, the recipient must be age 19 or older), (ii) a caretaker for the student, or (iii) the health care professional designated by the school to conduct the assessment.
      - i. Determination of Competency by School Nurse: A staff member may be determined to be competent by a school nurse to administer medication where the staff member:
        - passes a competency assessment every 3 years
        - that demonstrates the staff member can follow the minimal competencies
        - to the satisfaction of the school nurse (school nurses are the school district’s designated health care professionals).Training is not required. The school nurse shall, however, provide such training as the school nurse determines in the exercise of professional judgment to be appropriate given the experience level of the staff member and the anticipated medication administration for which the staff member will be responsible.
      - ii. Competency Certificate: Upon successful completion of the competency assessment, the school nurse shall give the Principal and the medication competent staff member written documentation of successful completion of competency assessment. The documentation may be by letter, certificate, or other written memoranda and shall include: the name of the school staff member who successfully completed the competency assessment; the date the competency assessment was conducted; and, the name, profession, and license number of the school nurse who conducted the competency assessment.
      - iii. Maintain Records of Assessments: The school shall maintain written documentation of successful completion of competency assessments, identification of the individual

providing direction and monitoring, and acceptance of the responsibility for direction and monitoring for a minimum of two (2) years.

- iv. Direction and Monitoring: A medication competent staff member is to be subject to direction and monitoring, which involves responsibility for observing and taking appropriate action regarding any desired effects, side effects, interactions, and contraindications associated with the medication. Direction and monitoring is to be done by a recipient with capability and capacity to make an informed decision about medications, a caretaker, or the school nurse. The school nurse is identified as a person being responsible for direction and monitoring and for each medication competent staff member is to accept responsibility for direction and monitoring of medication competent staff members in writing.
  - v. Errors. Medication competent staff members are to promptly report any medication errors or concerns to the school nurse.
3. Minimum Competencies:

The minimum competencies to be demonstrated by medication competent staff and to be implemented in practice by all school personnel engaged in medication administration are:

- a. Maintaining confidentiality.
- b. Complying with a competent recipient's right to refuse to take medication and, in the case of a non-competent, recognize the requirement to seek advice and consultation with the physician, physician's designee, or caretaker of the student providing direction and monitoring regarding the procedures and persuasive methods to be used to encourage compliance with medication provision. Recognizing that persuasive methods should not include anything that causes injury to the recipient.
- c. Maintaining hygiene and current accepted standards for infection control.
- d. Documenting accurately and completely.
- e. Safely providing medications according to the "five rights" ("five rights" means getting the right drug to the right recipient in the right dosage by the right route at the right time).
- f. Having the ability to understand and follow instructions.
- g. Practicing safety in application of procedures for storage, handling and administration of medications.
- h. Complying with limitations and conditions under which school personnel may provide medications.
- i. Having an awareness of abuse and neglect reporting requirements.
- j. Recognizing general unsafe conditions indicating that the medication should not be provided including change in consistency or color of the medication, unlabeled medication or illegible medication label, and those medications that have expired.
- k. Recognizing that unsafe conditions should be reported to the caretaker or licensed healthcare professional responsible for providing direction and monitoring (typically, the school nurse).
- l. Recognizing general conditions which may indicate an adverse reaction to medication such as rashes/hives, and general changes in recipient's condition which may indicate inability to receive medications, and that all such conditions shall be reported to the caretaker or licensed healthcare professional responsible for providing direction and monitoring (typically, the school nurse).

4. Routes of Medication Administered by School Personnel:
  - a. Routine Medication via Oral, Inhalation, Topical, and Instillation Routes: School nurses and medication competent staff may provide routine medications (meaning the frequency of administration, amount, strength, and method are specifically fixed) by the following routes:
    - i. Oral, which includes any medication given by mouth including sublingual (placing under the tongue) and buccal (placing between the cheek and gum) routes and oral sprays;
    - ii. Inhalation, which includes inhalers, and nebulizers. Oxygen may be given by inhalation;
    - iii. Topical application of sprays, creams, ointments, and lotions and transdermal patches; and
    - iv. Instillation by drops, ointments, and sprays into the eyes, ears, and nose.
  - b. Administration of Medication via Additional Routes, PRN Medication, and Observing and Reporting: School nurses and medication competent staff may provide medication by additional routes not listed in subparagraph “a” above (“additional routes”), provide PRN medication (PRN medication means an administration scheme in which a medication is not routine, is taken as needed, and requires assessment for need and effectiveness), or participate in observing and reporting for monitoring medications only under the following conditions:
    - i. In the case of a medication competent staff member, a determination has been made by the school nurse or by the student’s physician or duly licensed health care professional that these activities can be done safely for the specified recipient by the medication competent staff member and the determination is placed in writing.
    - ii. Directions for additional routes must be for recipient specific procedures and must be in writing.
    - iii. Directions for PRN medication must be in writing and include parameters for provision of PRN medication.
    - iv. Directions for observing and reporting for monitoring medication must be in writing and include the parameters for the observation and reporting.
    - v. School personnel administering the medication shall comply with the written directions.
  - c. Injections: School nurses will ordinarily be responsible for medications that must be provided or administered by injection. A medication competent staff member will not ordinarily administer medications by injection without specific training on injection administration. Students may be authorized to self-administer medication as hereafter provided.
5. Refusal to Administer Medication: School personnel may refuse to give a medication at school if after a reasonable and prudent research by a school health care professional as set forth in subparagraph "e" below, a decision has been made that the dosage prescribed exceeds that which is recommended in the Physician's Desk Reference, Mosby’s Nursing Drug Reference, the most recent edition of the Nursing Drug Handbook, or other pharmaceutical manuals handbook; or when a drug or substance is not currently approved by the FDA. When school personnel refuse to carry out a request to administer medication, the following procedure shall be followed:

- a. Notify the nursing supervisor who will notify the Superintendent.
- b. Notify attending physician by phone with follow-up in writing:
  - i. State concern for dosage or particular medication, etc.
  - ii. Make every attempt to work out a suitable solution - Example: Change of time of administration, change of dosage, change of medication;
  - iii. Follow-up in writing.
- c. Meet with parents:
  - i. State concern for dosage or medication;
  - ii. Offer alternatives - Example: Change of time so as not to be given during school hours.
- d. Consult with Nebraska State Board of Health for current procedures regarding refusal to follow written physician's orders.
- e. Research by health care professional:
  - i. Collect research articles from professional journals, organizations, etc.;
  - ii. Contact other physicians requesting their professional opinions and ask them to review current research;
  - iii. Contact state licensing boards and school nurse consultant;
  - iv. Consult with district's legal counsel;
  - v. Assemble all data for review;
  - vi. Present data to review team organized by the Superintendent;
  - vii. Decision rendered and implemented;
  - viii. Parents and physician contacted in writing; and
  - ix. Alter and update policies and procedures as needed.

Legal Reference: Neb. Rev. Stat. §§ 71-6718 to 71-6742; NDE Rule 59

Date of Adoption: May 18, 2009  
Date of Revision: February 14, 2024

**CARETAKER AUTHORIZATION FOR  
ADMINISTRATION OF PRESCRIPTION MEDICATION TO STUDENT**

The undersigned(s) is/are the caretaker(s), parent(s), guardian(s), or person(s) in charge of \_\_\_\_\_ (“the Student”). It is necessary that the Student receive \_\_\_\_\_ (medication), a physician-prescribed medication, during school intervals beginning on \_\_\_\_\_ (date) and continuing through \_\_\_\_\_ (date).

**CHECK ONE OF THE FOLLOWING:**

\_\_\_\_\_ I hereby authorize Raymond Central Public Schools to allow the Student to administer the above-described medication to himself/herself without monitoring or supervision by school personnel.

\_\_\_\_\_ I hereby request Raymond Central Public Schools, or its authorized representative, to administer the above-named medication to the Student, in accordance with the prescribing physician’s instructions, and agree to:

1. Submit this request to the principal or school nurse.
2. Make certain the Physician’s Request for the Administration of Prescription Medication by School Personnel is submitted to the principal or school nurse.
3. Make sure personally that the medication is received by the principal or school nurse and/or county nursing services administering it, in the container in which it was dispensed by the prescribing physician or licensed pharmacist.
4. Make sure personally that the container in which the medication is in is marked with the medication name, dosage, interval dosage, and date after which no administration should be given.
5. Submit a REVISED STATEMENT signed by the physician prescribing the medication to the principal or school nurse IF ANY OF THE INFORMATION PROVIDED BY THE PHYSICIAN CHANGES.
6. Provide directions to the school personnel providing the medication.
7. Provide monitoring of the medication’s effects, and assume full responsibility therefor.

I understand that unlicensed school personnel may be assigned to provide medication to the Student and hereby release the School District and the Board of Education of the School District and all employees, agents, and representatives of the School District from any liability concerning the providing or non-providing of the medication to the Student.

DATED this \_\_\_\_\_ day of \_\_\_\_\_, \_\_\_\_\_.

\_\_\_\_\_  
Work Telephone Number

\_\_\_\_\_  
Name of Student

\_\_\_\_\_  
Home Telephone Number

\_\_\_\_\_  
Parent/Guardian

\_\_\_\_\_  
Alternate Number for Parent

\_\_\_\_\_  
Parent/Guardian

**PROVISION OF MEDICATION TO STUDENT  
PHYSICIAN'S REQUEST FOR ADMINISTRATION OF PRESCRIPTION  
MEDICATION BY SCHOOL PERSONNEL**

Date \_\_\_\_\_

\_\_\_\_\_ (Student's full name) is under my care and must take medication which I have prescribed during the school day.

Name of medication (as it appears on container in which the medication is stored):

\_\_\_\_\_  
\_\_\_\_\_

Dosage and time \_\_\_\_\_

Date provision of medication is to begin \_\_\_\_\_

Date after which the medication should not be provided \_\_\_\_\_

Possible adverse reactions to be reported to physician:

\_\_\_\_\_  
\_\_\_\_\_

Special instructions for the provision and storage of the medication:

\_\_\_\_\_  
\_\_\_\_\_

\_\_\_\_\_  
Print or Type Name of Physician

\_\_\_\_\_  
Primary Phone Number

\_\_\_\_\_  
Signature of Physician

\_\_\_\_\_  
Secondary Phone Number



**Behavioral Points of Contact**

The Superintendent is delegated the authority to designate one or more behavioral awareness and health points of contact for each school building in the District. The behavioral awareness and health point of contact may be an administrator, nurse, psychologist, or another appropriate staff member. Each behavioral awareness and health point of contact will be trained in behavioral awareness and health and have knowledge of community service providers and other resources that are available for the students and families in the District. The District will maintain or have access to a registry of local mental health and counseling resources for students and parents.

The points of contact will be listed on the District's website and in the student handbook.

The Superintendent shall report the designated behavioral awareness and health points of contact to the Nebraska State Department of Education each year when requested by the Department.

In addition, all District employees who interact with students, as determined by the Superintendent, shall receive at least one hour of behavioral and mental health training with a focus on suicide awareness and prevention training each year. The Superintendent or designee shall be responsible for coordinating this training.

Legal Reference: Neb. Rev. Stat. §§ 79-11,159 & 79-11,160  
LB 705, § 4 (2023)

Date of Adoption: July 12, 2023

Discuss, Consider and Take Necessary Action to approve the purchase of six Newline Interactive White Boards

It is our plan to continue to purchase two interactive white boards for each building each year. These white boards replace the projection systems that are in each classroom with a much more robust interactive system. It allows students to interact directly with the instruction via the interactive board. Motion by Benes, second by Lange to approve the purchase of six Newline interactive boards and stands (75"/5 year warranty). RCV 4-0. Motion carried.



Kansas City Audio-Visual  
 REMIT TO: PO Box 24570  
 SHIP TO: 7535 Troost Ave.  
 Kansas City, MO 64131-0570  
 (800) 798-5228 | www.kcav.com

**QUOTE**  
**41004**

**BILL TO** **JOB LOCATION**

Raymond Central Public Schools Raymond Central Public Schools  
 1800 W Agnew Rd 1800 W Agnew Rd  
 Raymond, NE 68428 Raymond, NE 68428

**Contact:** Peggy Breitreutz **Contact:** Lynn Johnson  
 peggy.breitreutz@rcentral.org, (402)785-2615 lynn.johnson@rcentral.org, (402)785-2615  
**Date:** 01-23-2024 **Sales Rep:** Jason Foster  
**Expires:** 02-22-2024 jfoster@kcav.com, (800)798-5228 EXT 162

**TITLE**

Raymond Central PS - 6XNewlineIFP+Carts - 1-23-24

MANUFACTURER	PART NUMBER	DESCRIPTION	QTY	UNIT PRICE	TOTAL PRICE
Newline	TT-7521Q	750Q 4K LED Android 11.0 IFP w/ USB Type-C; includes: 5 -year Advanced Replacement Warranty, Engage, Lifetime Training, Dock to Dock Shipping, Standard Wall Mount	6.00	\$2,199.00	\$13,194.00
Newline	EPR8A50500-SQR	TRU TOUCH Mobile Stand	6.00	\$400.00	\$2,400.00
KCAV	SHIP-HANDLING	Shipping & Handling of all above items	1.00	\$0.00	\$0.00

**QUOTE SUMMARY**

EQUIPMENT	\$15,594.00
<b>Subtotal:</b>	<b>\$15,594.00</b>
<b>Tax:</b>	<b>\$0.00</b>
<b>TOTAL:</b>	<b>\$15,594.00</b>

**GENERAL TERMS**

**ORDER INSTRUCTIONS:**

1. Please be sure your purchase order reflects shipping/handling terms as indicated on this quote.
2. Pricing is valid for 30 calendar days from date of this quote unless otherwise noted by the expiration date.
3. To place your order, send this quote and purchase order to: orders@kcav.com. POs cannot be accepted on watermarked unauthorized quotes.

**HIGHLIGHTS:**

1. Credit card payments will incur a 4% convenience fee in allowed states.
2. Both hardware-only orders and installation projects over \$50,000 require a 50% deposit.
3. A 25% restocking fee may be charged on returned items. Return shipping is the responsibility of the customer.

**ALL SALES ARE SUBJECT TO KCAV TERMS & CONDITIONS:**

These Terms & Conditions are by and between Kansas City Audio-Visual, Inc. (the "Company") and the undersigned Customer (the "Customer").

1. GRANT OF SECURITY INTEREST: By signing below, Customer acknowledges that this contract serves as a security agreement within the meaning of the Uniform Commercial Code (UCC), and Customer agrees that Company may file such UCC financing statements as are appropriate to perfect Company's security interest in the equipment.
2. INSTALLATION: Customer hereby grants to Company or its agent the right to install the equipment, to the extent such installation is specified above. Customer represents and warrants that all necessary governmental and third-party approvals for installation of the equipment have been obtained, unless otherwise specified. Delays in installation caused by public agencies, manufacturers, suppliers, acts of God, pandemics, strikes or other union bargaining, and all acts not directly attributable to Company, shall not in any way affect the obligations of Customer, and Company's obligations with respect to such installation shall be suspended during the event causing the delay. Company shall not be responsible for damages from any such delay.
3. TAXES, FEES, AND PERMITS: Customer agrees to pay Company all applicable Federal, State, and local taxes, excises, permits, and fees. All dollars in this Agreement are pre-tax, unless otherwise stipulated.
4. SHIPPING: All shipments of equipment are FOB Company's distribution facilities.
5. RESPONSIBILITY: Until balance is paid, Customer agrees to take proper care of the equipment on premises and to be responsible for any damage or loss by fire, theft, casualty, or any other cause whatsoever, and will not permit or suffer same to be removed from the place of its location at address of Customer, without written consent of Company or assigns.
6. GENERAL: This Agreement constitutes the sole and entire understanding between the parties with respect to the subject matter hereof and supersedes all prior conversations, agreements, representations and promises, whether verbal or written. No modification of this Agreement shall be valid, unless made in writing and properly signed by each party. The provisions of this Agreement are severable; if any clause or provision shall be held invalid or unenforceable, in whole or in part, then such invalidity shall attach only to such clause or provision. Customer shall pay all attorneys' fees and other costs and charges incurred by Company in the collection of debt.
7. INFRASTRUCTURE: In the event that Company is installing equipment or systems that require connectivity to the Customer's network including, but not limited to, VOIP connectivity, internet access, wireless network access, firewall traversal, and/or port forwarding, Company may advise Customer as to the



Kansas City Audio-Visual  
REMIT TO: PO Box 24570  
SHIP TO: 7535 Troost Ave.  
Kansas City, MO 64131-0570  
(800) 798-5228 | www.kcav.com

QUOTE  
41004

network requirements, but any responsibility for infrastructure on the part of Company stops at the installed equipment's network jack or wireless connection and configuration of the network settings on the device sold by Company. Company is not responsible for updating network settings in the event the Customer's network changes. If the Customer's network is not "Plug and Play," then any custom network settings must be supplied by Customer to Company before the start of installation.

8. **INSTALLATION AND SITE PREPARATION:** Installation (field assembly, interconnection, equipment calibration and checkout) is to be performed by the Company's trained technical employees. The Company shall be entitled to employ subcontractors and/or agents to assist in or carry out, in whole or in part, the installation. In the event installation by Company employees is prevented by trade unions, Customer shall arrange with the trade unions at its own expense to complete installation. The Company is thereafter liable only for supervision of installation. Company agrees to coordinate with other trades to facilitate satisfactory work progress. If Company's work in progress is impeded by other trades and/or contractors (excluding Company's own subcontractors) or by scheduling delays due to Customer, time delays in the final installation as well as additional charges including labor, travel and reasonable expenses may result. Customer shall be responsible for preparing, at its own expense, the installation site in accordance with the Company's instructions, including the requirements specified in the proposal. Company shall not be responsible for any high-voltage electrical work, ceiling modifications, structural modifications, or mechanical systems modifications. Unless otherwise specified, Customer shall provide the Company with source code for any non-Company programmed remote control system required to be modified under the terms of this Agreement. Customer shall provide the Company with reasonable access to the installation site before delivery, based upon a mutually agreed upon project schedule, for purposes of determining site readiness for installation. Customer will designate an individual on Customer's staff to serve as a contact person for all site preparation and installation issues. Customer shall indemnify the Company against any loss, damage or claim arising out of the condition of the storage and installation premises. Customer shall obtain at its expense and keep effective all permissions, licenses, and permits whenever required for the installation and/or use of the equipment and the premises where the equipment shall be situated.

9. **LIMITATIONS OF WARRANTY - PRODUCTS OF OTHERS:** Unless otherwise specified, no warranty is provided for "consumables," including batteries, lamps, glassware and evacuated devices. Company's sole obligation with respect to any material or part identified in the quotation, literature, or specifications furnished to the Customer as manufactured or supplied by others, shall be to pass on to Customer the applicable manufacturer's warranties, if any.

10. **CHOICE OF LAW AND SEVERABILITY:** This agreement shall be interpreted in accordance with and governed in all respects by the law of Missouri. Venue shall be Kansas City, Missouri. Should any provision of this Agreement be found invalid or unenforceable by a court of competent jurisdiction or by operation of any applicable law, it shall not affect the validity of any other provision contained herein.

11. **PROJECT/ORDER CANCELLATION:** Customer must notify Company via both orders@kcav.com and sales representative in writing to cancel a project or order. Upon receipt of the notice, Company will acknowledge in writing Customer's order cancellation and provide the official date of cancellation. Customer agrees to pay Company for any labor expended or scheduled up to the order cancellation date, including but not limited to engineer time, design time, labor and travel completed, shipping costs, and other expenses related to the order. Assuming the equipment can be returned to the vendor, Customer agrees to pay a 25% restocking fee in addition to any applicable shipping charges. If the vendor will no longer accept the return of the equipment, Customer agrees to be responsible for the full cost of the equipment. Custom items may be noncancellable and are not returnable.

12. **RESTOCKING FEES:** In the event Customer wishes to return any equipment, Customer agrees to pay restocking fees of 25% of the sale price in addition to any applicable shipping charges.

13. **CHANGE ORDERS:** Any changes of scope made to the design of the system or the contractual agreements in implementation or functionality will require a mutually agreed upon "Change Order" form signed by an authorized representative for the Customer.

14. **TARIFFS:** If any products included in the proposal are impacted by international tariff changes, the Company reserves the right to adjust or cancel the proposal.

15. **PROFESSIONAL DEVELOPMENT SERVICES:** Unless specified otherwise, any purchased training or professional development services must be conducted within 12 months of placement of the sales order, unless mutually agreed upon otherwise in writing. Company will consider any contract to deliver professional development services fulfilled on the date 12 months after placement of sales order.

16. **DESIGN SERVICES:** All designs are the property of the Company. If Customer contracts with the Company to implement the design, the design shall become the property of Customer. If Customer wants to use the Company's design for an RFP, bid or any other purposes without implementation by the Company, the Company will advise Customer of the fee to purchase the design. Upon payment of the fee, the design becomes the property of Customer.

17. **CONFIDENTIALITY:** This Agreement and all drawings, specifications, and designs are the property of the Company. Proprietary information provided to Customer (or its agents) is for the sole purpose of demonstrating the Company's capabilities and shall be held in confidence. These materials may not be copied, distributed or disclosed in any way without the sole written permission of an authorized representative of the Company. Any effort to do so will be considered a violation of copyright law.

18. **PARAGRAPH HEADINGS:** The paragraph headings contained herein are for the convenience of reference only and shall not be construed to affect the interpretation or construction of any substantive provision of this Agreement.

#### **PAYMENT TERMS:**

1. **DELAYS:** All orders are subject to the Company's ability to make delivery at the time specified, and the Company shall not be liable for damages for failure to make partial or complete delivery. The Company shall not be liable for delays in delivery caused by forces not reasonably within Company's control (including but not limited to delays or defaults by carriers, extreme cold weather, floods, fires, storms, or other acts of God, war or act of public enemy or civil disturbance, strikes, lock-outs, shortages of labor or raw materials and supplies, action of any governmental authority, or any other force majeure event). Customer shall be liable for any added expenses incurred by the Company because of, including but not limited to, Customer's delay furnishing requested information to the Company; delays resulting from order changes by Customer; delays related to Customer's network configuration or other systems issues; or conditions affecting installation duration, off-hours or continuous workdays of 8 am to 5 pm.

2. **EQUIPMENT AND MATERIALS PRICE INCREASE:** Company shall be entitled to additional compensation from Customer in the event there is a significant increase in price of any specific item of equipment or materials of seven percent (7%) or more between the date the Agreement is signed and the date that equipment and materials are purchased for the work to be performed on the project.

3. **DELIVERY COSTS & CLAIMS:** Customer agrees to pay for all shipping or transportation costs of the equipment as and if stated on Company's proposal and/or the invoice. Company shall not be liable to Customer for any damage to or loss of equipment in transit. Company's only recourse as to such damage or loss shall be with or against carrier, and all claims must be filed with the carrier. Upon delivery, Customer must inspect and verify that contents match the packing list and are without damage. If there are any discrepancies or damages, Customer must notify Company in writing within three (3) business days, or such claims shall be waived.

4. **HARDWARE-ONLY ORDERS:** Orders over \$50,000 consisting of hardware only require a 50% deposit.

5. **INSTALLATION PROJECTS:** In keeping with industry standards, payment terms for projects over \$50,000 that involve installation are as follows:

- 50% deposit in advance of start of project
- 40% invoiced following delivery of hardware
- 10% remaining invoiced following completion of project

6. **PAYMENT & PAST DUE ACCOUNTS:** All payments are due within thirty (30) days of the invoice date unless an advance deposit is required on Company's quote. A finance charge of the lesser of 1.5% per month (18% - APR) or the highest rate permitted by law will be assessed on all past due accounts. Interest



Kansas City Audio-Visual  
 REMIT TO: PO Box 24570  
 SHIP TO: 7535 Troost Ave.  
 Kansas City, MO 64131-0570  
 (800) 798-5228 | www.kcav.com

**QUOTE**  
**41004**

charged on a past due invoice will be assessed from the date of the invoice. Customer agrees to reimburse Company for all attorneys' fees and court costs in connection with default of these payment terms by Customer.

7. CREDIT & CREDIT CARD PURCHASES: Credit payment terms must have the prior approval of Company. Company reserves the right to stop delivery of equipment or provision of services if Customer's financial condition becomes impaired or unsatisfactory to the Company. Additionally, Company may require payment in advance or other security, and, in the absence thereof, may cancel, without liability, the unfilled portion of an order. Credit card purchases shall be subject to a four percent (4%) convenience fee where allowed.

**IF YOU WISH TO ACCEPT THIS QUOTE AND RELATED STATEMENT OF WORK, PLEASE SIGN AND RETURN**

BUYER: (Print Name)	DATE:
SIGNATURE:	PO NO.:

If your purchasing or accounts payable departments require a purchase order for invoicing, please provide the PO number associated with acceptance of this quote and attach that PO with the signed quote. If signing this quote in lieu of a PO, please indicate what reference KCAV should use in the invoice PO field when invoicing. Please also verify that KCAV has correct shipping and billing address on file either by calling our office directly or by providing a PO at a later date with correct billing/shipping information.

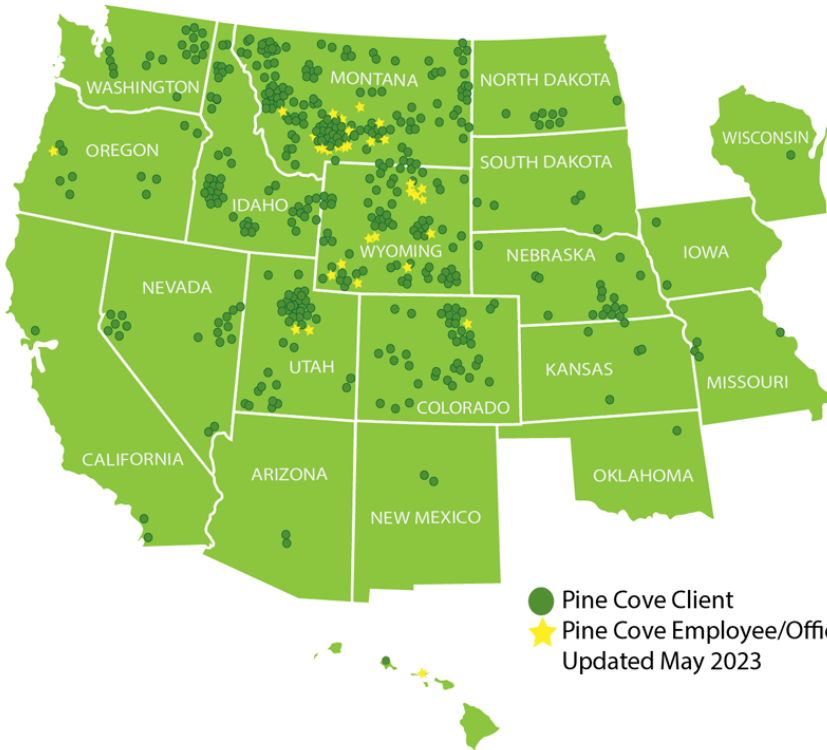

**pine:cove**  
CONSULTING

**Trusted IT Solutions  
Since 1993**

**CYBERSECURITY | NETWORKING | COMMUNICATION  
| PHYSICAL SECURITY | MANAGED SERVICES | STUDENT SAFETY |**

**We have prepared a quote for you:**

**UPS**

Quote # 009145  
Version 1

**Prepared for:**

**Raymond Central Public  
Schools**

Jaxn Kobza  
jaxn.kobza@rcentral.org

UPS

Description	Price	Qty	Ext. Price
Eaton 5P UPS 750VA 600W 120V Line-Interactive UPS, 5-15P, 5x 5-15R Outlets, True Sine Wave, Cybersecure Network Card Option, 1U - 1U Rack-mountable - 4 Minute Stand-by - 110 V AC Input - 132 V AC Output - 5 x NEMA 5-15R 	\$764.00	1	\$764.00
Shipping, Handling and Insurance	\$107.50	1	\$107.50
<b>Subtotal:</b>			<b>\$871.50</b>



# UPS

### Prepared by:

**Pine Cove Consulting**  
sales@pinecc.com  
800-432-0346

### Prepared for:

**Raymond Central Public Schools**  
1800 W. Agnew Road  
Raymond, NE 68428  
Jaxn Kobza  
40278526851306  
jaxn.kobza@rcentral.org

### Quote Information:

**Quote #: 009145**  
Version: 1  
Delivery Date: 01/25/2024  
Expiration Date: 02/22/2024

## Quote Summary

Description	Amount
UPS	\$871.50
<b>Total:</b>	<b>\$871.50</b>

This proposal shall not be used for the creation of RFP/RFQ documents, by the customer.

TERMS: Due on receipt of invoice.

Access to the customer portal for online payment is @ <https://pinecc.connectboosterportal.com>

Applicable fees and taxes not included.

Discuss, Consider and Take Necessary Action to approve Aaron Haake as Raymond Central Education Foundation board member

Motion by Burklund, second by Benes to approve Aaron Haake as a Raymond Central Educational Foundation Board Member. RCV 4-0. Motion carried.

Discuss, Consider and Take Necessary Action to approve a lease agreement for the 67 acres of farmland

Motion by Lange, second by Burklund to approve a 3-Year Lease Agreement with Kyle and Jessica Schwarting for the 67 acres of farmland at \$245.00/acre. RCV 4-0. Motion carried.

## CASH RENT FARM LEASE

This CASH RENT FARM LEASE ("Lease") is entered into as of the 14th day of February, 2024, by and between LANCASTER COUNTY SCHOOL DISTRICT 55-0161, A/K/A RAYMOND CENTRAL PUBLIC SCHOOL DISTRICT ("Landlord") and Kyle & Jessica Schwarting ("Tenant").

In consideration of the mutual promises, covenants and agreements herein, Landlord and Tenant hereby agree as follows:

1. Leased Premises. Landlord hereby leases to Tenant and Tenant hereby leases from Landlord the real estate described as:

Lot 22, Irregular Tracts in the Southeast Quarter of Section 9, Township 12 North, Range 6 East of the 6<sup>th</sup> P.M., Lancaster County, Nebraska.

The Leased Premises consists of approximately 66.0 acres of dryland agricultural cropland and .98 other acres.

2. Term. The term of this Lease shall begin March 1, 2024, and shall automatically terminate without any further notice on the last day of February, 2027, unless terminated earlier as provided herein (the "Term"). The Term of this Lease may only be extended by a writing signed by both Landlord and Tenant.

3. Rental. For the first year of this Lease, the Landlord and Tenant hereby agree to a cash rental amount of SIXTEEN THOUSAND, ONE HUNDRED SEVENTY AND NO/100THS DOLLARS (\$16,170.00), which is based on a per-acre rental rate of two hundred forty-five dollars (\$245) per acre. The annual cash rental amount shall be adjusted for the dollar amount value of any in-kind services provided by the Tenant to the Landlord by mutual agreement entered during each annual lease Term. The annual rent payment, after deduction of the agreed value of any in-kind services, shall be paid by Tenant on or before April 28 of each year of the Term. All rent not received by the Landlord when due shall bear interest from the date due until paid at the rate of 12% per annum.

4. General Liability, Indemnification and Insurance. Tenant agrees to indemnify and hold harmless Landlord and Landlord's employees, agents and assigns from any and all claims, liabilities, losses, costs and expenses (including without limitation attorneys' fees) arising from, or in connection with, the condition, use or control of the Leased Premises or any part thereof or object situated thereon, including without limitation the improvements and equipment thereon, and for any act done by Tenant or any employee, agent, invitee or licensee of Tenant.

Tenant agrees that Tenant will, at all times during the term of this Lease, maintain and pay for a reasonable comprehensive general liability insurance policy affording protection to Landlord and naming Landlord as an additional insured. Tenant further agrees, upon request, to deliver to Landlord a certificate of insurance and copy of the policy evidencing that such insurance coverage is in effect. Further, Tenant shall require any harvester or other person or entity hired by him as an independent contractor to perform services on the Leased Premises to procure before commencing

such services and to maintain during the performance of such services, at no cost or expense to Landlord, similar insurance insuring Landlord and Tenant against any and all possible liability for injuries to or death of the independent contractor or any employee of such independent contractor at any time in or about the Leased Premises.

Tenant shall maintain Tenant's own liability and workers' compensation insurance for the protection of Tenant's employees, agents, equipment, and machinery. Tenant further agrees to obtain automobile liability insurance on all owned, non-owned, hired, or leased automotive equipment in conjunction with operations.

5. Landlord's obligations. During the Term of this Lease, the Landlord shall make all reasonable efforts to provide that any sale of the Leased Premises, whether by contract or foreclosure, be made subject to this Lease. The Landlord shall be responsible for paying all real estate taxes and assessments on the Leased Premises.

6. Tenant's Obligations. During the Term of this Lease, Tenant shall:

a. Farm the Leased Premises in a workmanlike manner in accordance with the standards of good husbandry.

b. Pay all costs of production of the crop on and operation of the Leased Premises and other related expenses, whether ordinary or extraordinary, direct or indirect, except as otherwise provided herein.

c. Prevent noxious weeds from going to seed on the Leased Premises, destroy such weeds and pay any tax, fine, penalty or fee imposed against the Leased Premises by local municipalities for destroying noxious weeds in the event Tenant fails to do so.

d. Haul and spread all fertilizers on appropriate fields at times and in quantities consistent with environmental protection requirements and comply with all applicable laws.

e. Keep the Leased Premises and the Property neat and orderly, and prevent all unnecessary waste, loss or damage to the same.

f. Assume and be responsible for all (i) damage and injury to any farm equipment, crop and field machinery; irrigation equipment, the Property and other personal property of Tenant, Tenant's employees, agents or invitees; and (ii) personal injury and damages of every type and kind to Tenant, Tenant's employees, agents and invitees.

g. Tenant shall not incur any expense or any obligation of any kind or for any purpose that might be charged to the Landlord or attaches as a lien to the Landlord's Real Property.

7. Alterations, Repairs and Maintenance.

a. Tenant shall, at his sole cost, provide all necessary and appropriate maintenance and repairs to the Leased Premises, all improvements thereon and the Property.

b. Tenant shall be permitted to remove existing fences and to level existing fence lines.

c. Tenant may, at his sole cost, irrigate the Leased Premises.

8. Encumbering Title. Tenant shall not do any act which shall in any way encumber the title or interest of Landlord in and to the Leased Premises, nor shall Tenant allow the interest or estate of Landlord in the Leased Premises to be in any way subject to any claim by way of lien or encumbrance, whether by operation of law or by virtue of any express or implied contract by Tenant. Any claim to, or lien upon the Leased Premises arising from any act or omission of Tenant shall accrue only against the leasehold estate and interest of Tenant and shall be subject and subordinate to the paramount title and rights of Landlord.

9. Assignment; Subletting. Tenant shall not assign any of its rights hereunder or sublet this Lease without Landlord's written consent. Landlord may assign its rights hereunder at any time without Tenant's consent, and upon such assignment shall be relieved of all obligations, duties, liabilities and responsibilities hereunder as of the date of such assignment.

10. Default; Remedies. Any one or more of the following events shall constitute an event of default under this Lease;

a. Abandonment or vacation of the Leased Premises or the Property during the term hereof;

b. Failure to pay the Rent when due or any other payment required to be made by Tenant hereunder;

c. Tenant's breach, default or failure to comply with, or keep, observe or perform any of the other covenants, agreements, representations or warranties described herein to be kept, observed or performed by Tenant.

Upon the occurrence of any one or more of such events of default, Landlord may, at its election, terminate this Lease by giving written notice to Tenant. Termination shall be effective on the date specified in the notice. Upon termination of this Lease, Tenant shall immediately surrender possession of and vacate the Leased Premises and shall deliver possession thereof to Landlord. Following termination, Landlord shall have the full and free right to enter into and upon the Leased Premises with or without process of law and repossess the Leased Premises and expel or remove Tenant and any others who may be occupying, possessing or using the same. In such event, Landlord shall not be deemed in any manner guilty of trespass, eviction or forcible entry or detainer and shall not incur any liability to Tenant or any other person for any damage resulting therefrom. Further, such actions by Landlord shall not relinquish Landlord's right to recover rent from Tenant or any other right given to Landlord hereunder or by operation of law. Upon termination of this Lease by Landlord, Tenant shall have no right to return to the Leased Premises nor to harvest the crops remaining, if any, without the prior written consent of Landlord. Landlord reserves the right to supervise any such harvest by Tenant and to impose upon Tenant's reentry and harvest any terms and conditions Landlord deems appropriate.

Tenant shall be liable for and hereby agrees to pay any and all losses, liabilities, costs and expenses, including without limitation attorneys' fees, which Landlord incurs, directly or indirectly, in connection with any of the aforesaid defaults or the enforcement of Landlord's rights and remedies under this Lease as a result of such default.

Landlord's remedies shall be cumulative and shall be in addition to every other remedy

given hereunder.

Landlord's failure to exercise or delay in exercising any right, power or privilege hereunder shall not be construed as a waiver or relinquishment of any future right to strictly enforce any right, power or privilege. The acceptance by Landlord of any payment of rent or other charges hereunder after the termination by Landlord of this Lease shall not, in the absence of agreement in writing to the contrary signed by Landlord, be deemed to restore this Lease but shall be construed as a payment on account.

11. Surrender. Upon the expiration or termination of this Lease, Tenant will at once surrender and deliver the Leased Premises to Landlord in as good condition and repair, as at the time Tenant takes possession of same, normal wear and tear excepted, without further notice or demand. All additions, repairs, replacements and all improvements, temporary or permanent, in or upon the Leased Premises placed, affixed or installed by Tenant shall become Landlord's property and shall remain upon such expiration or termination of this Lease, without compensation, allowance or credit to Tenant.

Upon the expiration or termination of this Lease, Tenant shall remove Tenant's property from the Leased Premises; provided, however, that Tenant shall repair any injury or damage to the Leased Premises which may result from such removal. If Tenant does not remove Tenant's property from the Leased Premises prior to the termination of the Lease, Landlord may treat such property as having been conveyed to Landlord with the Lease as a Bill of Sale.

12. Landlord's Lien for Rent and Performance. Any Landlord's lien provided by law on crops grown or growing shall be security for the rent herein specified and for the faithful performance of the terms of the Lease and may be enforced in the manner prescribed by law.

13. Landlord's Right to Entry During Term of Lease. During the Term of this Lease, Landlord reserves for itself, its agent and employees, the right to enter upon the Leased Premises at any reasonable time for any reasonable purposes, including without limitation, inspecting the Leased Premises. This right of entry is separate, apart from and in addition to Landlord's right of entry in the event of default and other rights provided herein and by operation of law.

14. Field Work for Next Year's Crop. Tenant is authorized to prepare seedbed and plant for crops to be harvested in the next crop year only after receiving written permission to do so from the Landlord. Where permission to prepare seedbed and plant crops is granted and the Leased Premises are not leased to the Tenant for the next lease year, Tenant will be reimbursed at going custom rates for the work performed and material (seed, fertilizer, etc.) used on the Leased Premises. In such an event, Tenant agrees to release all interest in the land and crops on which the seedbed is prepared and/or planted. The granting of permission to prepare the seedbed and planting does not constitute rental of the Leased Premises for the next lease year. If Tenant proceeds to prepare the seedbed or plants or performs any additional work on or about the Leased Premises not specifically authorized in this Lease without the prior written consent of Landlord, Landlord shall not be obligated to compensate the Tenant for any such work, and Tenant shall have no additional rights upon the termination or expiration of this Lease by virtue thereof.

15. Eminent Domain. In the event that all or part of the Leased Premises is taken or condemned by the right of eminent domain and any part of the Leased Premises are rendered unsuitable for agricultural purposes, this Lease shall, at the sole option of Landlord, terminate as

to the part of the Leased Premises so taken, condemned or sold. All rent for such part shall be paid by Tenant up to the date of transfer of possession to the condemning authority, and all compensation awarded or paid for the taking or sale shall belong to the Landlord, and Tenant shall have no claim against Landlord for the value of any otherwise unexpired portion of the Lease term; provided, however, that Tenant shall be entitled to any award expressly made to Tenant for Tenant's share of the crops, if any, which existed at the time of the condemnation award.

16. Landlord's Right to Cure. Landlord may, but shall not be obligated to, cure any default by Tenant and whenever Landlord so elects, all costs and expenses paid by Landlord in curing such default, including reasonable attorneys' fees, shall be an obligation of and immediately due from Tenant.

17. Complete Agreement; Amendments. This Lease constitutes the entire agreement between Landlord and Tenant, superseding all previous lease agreements, if any, entered into between them. None of the covenants, terms or conditions of this Lease shall in any manner be altered, waived, modified, changed or abandoned except by a written instrument, duly signed and acknowledged by both Landlord and Tenant.

18. Successors. The terms, covenants and conditions hereof shall be binding upon and inure to the benefit of Landlord's and Tenant's heirs, personal representatives, assigns and successors; provided, however, that Tenant's assigns shall not be entitled to the benefits of this Lease, unless Landlord consented in writing to such assignment.

19. Notices. Any notice required under this Lease shall be in writing and sent certified mail, return receipt requested to Landlord and Tenant at the following addresses, or such other addresses as they may notify each other of from time to time:

<p>Notice to Lessor: Lynn Johnson, Superintendent Raymond Central School District 1800 West Agnew Road Raymond, NE 68428-9783</p>	<p>Notice to Lessee: Kyle &amp; Jessica Schwarting 6272 Agnew Road Ceresco, NE 68017</p>
<p>With a copy to: Justin Knight Perry, Guthery, Haase &amp; Gessford, P.C., L.L.O. 233 South 13th Street, Suite 1400 Lincoln, NE 68508</p>	<p>With a copy to:</p>

20. Time is of the Essence. Time is of the essence of this Lease, and all provisions herein relating thereto shall be strictly construed.

21. Captions. The captions of this Lease are for convenience only and are not to be construed as part of this Lease and shall not be construed as defining or limiting in any way the scope or intent of the provisions thereof.

22. Severability. If any term or provision of this Lease shall to any extent be held invalid or unenforceable, the remaining terms and provisions of this Lease shall not be affected thereby, but each term and provision of this Lease shall be valid and enforceable to the fullest extent permitted by law.

23. Applicable Law. This Lease shall be construed and enforced in accordance with the laws of the State of Nebraska.

24. Number, Gender. The words "Landlord" and "Tenant" wherever used in this Lease shall be construed to mean Landlords and Tenants in all cases in which there is more than one Landlord or Tenant, and to apply to individuals, male or female, or to firms or corporations, as the same may be described as Landlord and Tenant in this Lease, and the necessary grammatical changes shall be assumed in each case as though fully expressed.

25. Transfer of Leased Premises. If the Leased Premises are transferred during the term hereof, the transferee shall obtain all rights of the Landlord hereunder and the rent thereunder shall be paid in accordance with written instructions given by such transferee to Tenant.

The parties hereto have executed this Lease as of the date and year first above written.

TENANT:

Kyle Schwarting  
6272 Agnew Road  
Ceresco, NE 68017

---

Kyle Schwarting, Tenant

LANDLORD:

LANCASTER COUNTY SCHOOL DISTRICT  
55-0161, A/K/A RAYMOND CENTRAL PUBLIC SCHOOL DISTRICT

Brad Breitzkreutz, President

Attest:

Bill Lange, Secretary

Discuss, Consider and Take Necessary Action to Approve the District Calendar for 2024-2025

The calendar committee met to discuss and develop the proposed calendar which has 1/2 day less in student days because of the noon release at the end of both semesters; an early dismissal was added on January 31 to facilitate our home girls/JV boys wrestling meet (this year it ended at 11:00 PM); the PD day in September was moved to the preservice time frame to introduce the instructional model to all staff; and an additional 'no school day' after PTC to facilitate a long weekend for parents/staff. Motion by Lange, second by Breitreutz to approve the 2024-2025 school calendar as presented with the first day of school being Tuesday, August 13, 2024. RCV 4-0. Motion carried.

# RAYMOND CENTRAL PUBLIC SCHOOLS

## 2024-2025

### SCHOOL CALENDAR

**School Start and End Times:** Elementary: 8:15 AM - 3:15 PM  
 Junior/Senior High School: 8:10 AM - 3:30 PM    PreSchool: 8:45 AM - 3:00 PM

AUGUST				
M	T	W	T	F
			1	2
5	6	7	8	9
12	13	14	15	16
19	20	21	22	23
26	27	28	29	30
SEPTEMBER				
M	T	W	T	F
2	3	4	5	6
9	10	11	12	13
16	17	18	19	20
23	24	25	26	27
30				
OCTOBER				
M	T	W	T	F
	1	2	3	4
7	8	9	10	11
14	15	16	17	18
21	22	23	24	25
28	29	30	31	
NOVEMBER				
M	T	W	T	F
				1
4	5	6	7	8
11	12	13	14	15
18	19	20	21	22
25	26	27	28	29
DECEMBER				
M	T	W	T	F
2	3	4	5	6
9	10	11	12	13
16	17	18	19	20
23	24	25	26	27
30	31			

<b>AUGUST 2024</b> 5-6 Monday & Tuesday - New Teacher Workdays 7-12 Wednesday, Thursday, Friday & Monday - Teacher Workdays 13 Tuesday - FIRST DAY OF SCHOOL - NOON DISMISSAL 13 Tuesday - Teacher Workday - Noon-3:45 pm
<b>SEPTEMBER 2024</b> 2 Monday - NO SCHOOL - Labor Day
<b>OCTOBER 2024</b> 11 Friday - End of 1st Qtr - NO SCHOOL - Teacher Professional Development 17 Thursday - NO SCHOOL - Teacher Professional Development 17 Thursday - NO SCHOOL - Parent-Teacher Conferences 12:30-7:30 18 Friday - NO SCHOOL
<b>NOVEMBER 2024</b> 1 Friday - NO SCHOOL - Teacher Professional Development 27-29 Wednesday, Thursday & Friday - NO SCHOOL - Thanksgiving Break
<b>DECEMBER 2024</b> 20 Friday - End of 2nd Qtr - Noon Dismissal 22-26 NSAA Moratorium - Gyms Closed 23-31 NO SCHOOL - Winter Break
<b>JANUARY 2025</b> 1-2 Wednesday & Thursday - NO SCHOOL - Winter Break 3 Friday - NO SCHOOL - Teacher Professional Development 6 Monday - School resumes for students 20 Monday - NO SCHOOL - Teacher Professional Development 31 Friday - Student Early Dismissal (1:15 Elementary / 1:30 Jr-Sr High)
<b>FEBRUARY 2025</b> 17 Monday - NO SCHOOL
<b>MARCH 2025</b> 7 Friday - NO SCHOOL - End of 3rd Qtr - Teacher Professional Development 13 Thursday - NO SCHOOL - Teacher Professional Development 13 Thursday - NO SCHOOL - Parent-Teacher Conferences 12:30-7:30 14 & 17 Friday & Monday - NO SCHOOL
<b>APRIL 2025</b> 18 & 21 Friday & Monday - NO SCHOOL
<b>MAY 2025</b> 10 Saturday - Graduation Ceremony at 2:00 pm 21 Wednesday - LAST DAY OF SCHOOL - NOON DISMISSAL 21 Wednesday - End of 4th Qtr / Teacher Workday - Noon-3:45 pm

JANUARY				
M	T	W	T	F
		1	2	3
6	7	8	9	10
13	14	15	16	17
20	21	22	23	24
27	28	29	30	31
FEBRUARY				
M	T	W	T	F
3	4	5	6	7
10	11	12	13	14
17	18	19	20	21
24	25	26	27	28
MARCH				
M	T	W	T	F
3	4	5	6	7
10	11	12	13	14
17	18	19	20	21
24	25	26	27	28
31				
APRIL				
M	T	W	T	F
	1	2	3	4
7	8	9	10	11
14	15	16	17	18
21	22	23	24	25
28	29	30		
MAY				
M	T	W	T	F
			1	2
5	6	7	8	9
12	13	14	15	16
19	20	21	22	23
26	27	28	29	30

- First Day of School
- Student Early Dismissal
- NO SCHOOL
- End of Quarters
- Possible Last Day of School
- Teacher Professional Development
- New Teachers Only
- Parent-Teacher Conferences



# RAYMOND CENTRAL PUBLIC SCHOOLS

## 2024-2025

### SCHOOL CALENDAR

**School Start and End Times:** Elementary: 8:15 AM - 3:15 PM  
 Junior/Senior High School: 8:10 AM - 3:30 PM    PreSchool: 8:45 AM - 3:00 PM

AUGUST					ST	Tch						Tch	ST	JANUARY				
M	T	W	T	F										M	T	W	T	F
			1	2			<b>AUGUST 2024</b>					1				1	2	3
5	6	7	8	9	3		5-6 Monday & Tuesday - New Teacher Workdays					5	5	6	7	8	9	10
12	<del>13</del>	14	15	16	3.5	5	7-12 Wednesday, Thursday, Friday & Monday - Teacher Workdays					5	5	13	14	15	16	17
19	20	21	22	23	5	5	13 Tuesday - FIRST DAY OF SCHOOL - NOON DISMISSAL					5	4	20	21	22	23	24
26	27	28	29	30	5	5	13 Tuesday - Teacher Workday - Noon-3:45 pm					5	5	27	28	29	30	<del>31</del>
SEPTEMBER							<b>SEPTEMBER 2024</b>							FEBRUARY				
M	T	W	T	F			2 Monday - NO SCHOOL - Labor Day <th></th> <th></th> <th>M</th> <th>T</th> <th>W</th> <th>T</th> <th>F</th>							M	T	W	T	F
2	3	4	5	6	4	4	<b>OCTOBER 2024</b>					5	5	3	4	5	6	7
9	10	11	12	13	5	5	11 Friday - End of 1st Qtr - NO SCHOOL - Teacher Professional Development					5	5	10	11	12	13	14
16	17	18	19	20	5	5	17 Thursday - NO SCHOOL - Teacher Professional Development					4	4	17	18	19	20	21
23	24	25	26	27	5	5	17 Thursday - NO SCHOOL - Parent-Teacher Conferences 12:30-7:30					5	5	24	25	26	27	28
30					1	1	18 Friday - NO SCHOOL							MARCH				
OCTOBER							<b>NOVEMBER 2024</b>							M	T	W	T	F
M	T	W	T	F			1 Friday - NO SCHOOL - Teacher Professional Development					5	4	3	4	5	6	7
1	2	3	4		4	4	27-29 Wednesday, Thursday & Friday - NO SCHOOL - Thanksgiving Break					4.5	3	10	11	12	13	14
7	8	9	10	11	4	5	<b>DECEMBER 2024</b>					4	4	17	18	19	20	21
14	15	16	17	18	3	4.5	20 Friday - End of 2nd Qtr - Noon Dismissal					5	5	24	25	26	27	28
21	22	23	24	25	5	5	22-26 NSAA Moratorium - Gyms Closed					1	1	31				
28	29	30	31		4	4	23-31 NO SCHOOL - Winter Break							APRIL				
NOVEMBER							<b>JANUARY 2025</b>							M	T	W	T	F
M	T	W	T	F			1-2 Wednesday & Thursday - NO SCHOOL - Winter Break					4	4	1	2	3	4	
1					1	1	3 Friday - NO SCHOOL - Teacher Professional Development					5	5	7	8	9	10	11
4	5	6	7	8	5	5	6 Monday - School resumes for students					4	4	14	15	16	17	18
11	12	13	14	15	5	5	20 Monday - NO SCHOOL - Teacher Professional Development					4	4	21	22	23	24	25
18	19	20	21	22	5	5	31 Friday - Student Early Dismissal (1:15 Elementary / 1:30 Jr-Sr High)					3	3	28	29	30		
25	26	27	28	29	2	2	<b>FEBRUARY 2025</b>							MAY				
DECEMBER							<b>MARCH 2025</b>							M	T	W	T	F
M	T	W	T	F			17 Monday - NO SCHOOL					2	2	5	6	7	8	9
2	3	4	5	6	5	5	<b>APRIL 2025</b>					5	5	12	13	14	15	16
9	10	11	12	13	5	5	18 & 21 Friday & Monday - NO SCHOOL					5	5	19	20	21	22	23
16	17	18	19	20	4.5	5	<b>MAY 2025</b>					4	2.5	26	27	28	29	30
23	24	25	26	27			10 Saturday - Graduation Ceremony at 2:00 pm											
30	31						21 Wednesday - LAST DAY OF SCHOOL - NOON DISMISSAL											
							21 Wednesday - End of 4th Qtr / Teacher Workday - Noon-3:45 pm											
					85.0	93.5						95.5	89.5					

-3    -3    built in snow days  
 92.5    86.5

- First Day of School
- Student Early Dismissal
- NO SCHOOL
- End of Quarters
- Possible Last Day of School
- Teacher Professional Development
- New Teachers Only
- Parent-Teacher Conferences

186.0    Teacher days  
 171.5    Student days

Discuss, Consider and Make Necessary Changes to the Preschool Handbook

Motion by Benes, second by Burklund to amend Enrollment Eligibility guidelines for our preschool program as follows. RCV 4-0. Motion carried.

PRESCHOOL ENROLLMENT POLICY - Enrollment procedures used to determine the preschool class list are based on the following list of criteria in order of priority:

- a. Child on an Individualized Education Plan (IEP) or Individualized Family Service Plan (IFSP), living in our school district will have first priority for acceptance. The State of Nebraska set up the preschool program to help those children with the highest needs.
- b. Those students living in our school district who will turn four by July 31, based on when application was received.
- c. Those students living in our school district who will turn three by July 31, based on when application was received.
- d. If there are still available spots, non-district students may be enrolled with priority given to staff children and those who have siblings enrolled in the district, and lastly, those that can evidence an intent to enroll in the District as a first child of their family.
- e. If a child who does not reside in our district qualifies for an IEP after being enrolled in our program, we will allow them to finish the year if we have the service provider capacity. Subsequent year placement is not guaranteed and is based on option enrollment policies.



# Raymond Central Public Schools

## PRESCHOOL HANDBOOK

2023-2024

1800 W. Agnew Rd.  
Raymond, NE 68428  
(402) 785-2615

<https://www.rcentral.org/>





## **Welcome to Raymond Central Public Schools Preschool**

We are excited to have you and your child be part of our program! This handbook is designed to answer some of your questions and give you an overview of our policies and procedures. Feel free to contact your child's teacher or the office with questions or concerns you may have.

---

The Raymond Central Preschool is part of Raymond Central Public Schools District 161. All policies set forth by the District or Board of Education in the District's Parent Handbook are in effect for the Preschool. The additional guidelines set forth in this Preschool Handbook are solely for our preschool and address issues that only pertain to preschool students and the program.

---

State funded early childhood education programs must adhere to age eligibility guidelines set by the State as stated in Rule 11. Children who are eligible to enroll in kindergarten (those who reach 5 by July 31st of the current year), may not participate in a State funded preschool program.



## Preschool Staff

Megan Kemnitz	Preschool 4 Teacher	megan.kemnitz@rcentral.org
Kristy Sears	Preschool 4 Para	kristy.sears@rcentral.org
Cindra Jensen	Preschool 4 Para	cijensen@rcentral.org
Faith Boyd	Preschool 3 Teacher	faith.boyd@rcentral.org
Allison Prorok	Preschool 3 Para	allison.prorok@rcentral.org
Nikki Haas	Preschool 3 Para	nikki.haas@rcentral.org
Linda Hennessey	Early Childhood Speech Pathologist	lhennessey@esu.org
Jean Danley	Administrative Assistant	jdanley@rcentral.org
Cheryl Rieck	Supt Administrative Assistant	crieck@rcentral.org
Amanda Ehlers	School Nurse	amanda.ehlers@rcentral.org

## Administrators

Lynn Johnson	Superintendent	lynn.johnson@rcentral.org
Steve Rose	K-5 Principal	srose@rcentral.org
Deb Kruse	Asst K-5 Principal	deb.kruse@rcentral.org
Mark Smith	6-12 Principal	mark.smith@rcentral.org
Tony Kobza	Asst 6-12 Principal/Act Director	tony.kobza@rcentral.org
Amanda Coufal	Director of Special Education	amanda.coufal@rcentral.org

## Board of Education

Brad Breitreutz	President
Cathy Burklund	Vice President
Matt Blanchard	Treasurer
Bill Lange	Secretary
Mary Benes	Member
Derek Matulka	Member

# PRESCHOOL



## **Who may attend?**

Preschool students may not turn five years old on or before July 31, 2023 and must be at least three years old on or before July 31, 2023. Priority will be given to students who will enroll in Kindergarten in August of 2024.

## **Where is Raymond Central Preschool located?**

At the north end of the Raymond Central Jr-Sr High School building, 1800 W Agnew Rd, Raymond.

## **When is Preschool?**

Two preschool sessions will be offered for the 4-year-old classroom: either Monday/Wednesday or Tuesday/Thursday. One preschool session will be offered on Tuesday/Thursday for the 3-year-old classroom. Preschool is in session 8:45am-3:00pm. Students may be dropped off at 8:30am.

## **What will my child learn?**

The preschool program uses Connect 4 Learning (C4L) and Creative Curriculum. Both are research and evidence-based comprehensive curriculums designed for early childhood. It addresses all areas of early learning: language and literacy, math, science, physical skills, and social skills. It provides children an opportunity to learn in a variety of ways - through play, problem solving, movement, art, music, drawing and writing, listening, and storytelling.

Curriculum is a framework for learning opportunities and experiences. It is a process by which learners obtain knowledge and understanding, while developing life skills. It is continually revised and evaluated to make learning fun and exciting.

## **What services are provided at Raymond Central Preschool?**

Each class is taught by a teacher who is certified to teach young children. Support to the teacher and the children is provided by two paraprofessionals and other staff which includes but is not limited to Supervisors, Special Education Providers, Speech Language Pathologist, Occupational Therapist, District Special Education Director, and a School Psychologist.

# INDEX

Absences.....	6
Administering Medication.....	6
Arrival and Departure Times.....	6
Bathroom Issues.....	6
Birthdays.....	7
Birth Certificates.....	7
Calendar.....	7
Child Assessment.....	7
Child Protection Policies.....	8
Class Size.....	8
Clothing.....	8
Communication.....	8
Contacting the Teacher.....	9
Daily Schedule.....	9
Discipline.....	9
District Website.....	9
Early Childhood Advisory Committee.....	9
Enrollment Policy.....	10
Emergency Drills.....	10
First Aid Kit.....	10
Family.....	10
Hand Washing Practices.....	10
Home Visits.....	10
Illnesses.....	11
Immunizations.....	11
Inclusion.....	11
Late Registration.....	11
Lunch/Snack.....	11
Open House.....	12
Outdoor Play.....	12
Parent-Teacher Conferences.....	12
Personal Possessions.....	12
Pictures and Videos.....	13
School Closings.....	13
School Health Screening.....	13
Student Behavior.....	13
Support Services.....	14
Transportation.....	14
Tuition.....	14
Notice of Nondiscrimination.....	15
Preschool Handbook Parent Form.....	16

**ABSENCES** - If your child is ill or will be absent, please call 402-665-3651 to inform us. The secretary at this number will let your child's teacher know your child will be gone.

If your child is not in preschool and the teacher has not been informed of the absence, school personnel will make a reasonable effort to contact the parents to ensure that your child is safe and where they are supposed to be.

If your child is a bus rider, please also contact the bus driver to let them know your child will not be riding.

**ADMINISTERING MEDICATION (Guidelines)** - Whenever possible, your child should be provided medications by you outside of school hours. In the event it is necessary that the child take or have medication available at school, parents/guardians must provide a signed written consent for the child to be given medication at school. A consent form is available at the school health office. Repackaged medications will not be accepted. All medications also require a physician's authorization to be given at school. The school nurse may limit medications to those set forth in the Physician's Desk Reference (PDR).

### **ARRIVAL AND DEPARTURE TIMES**

- **Drop Off**
  - Families may drop their child off between 8:30am and 8:45am at the classroom door.
  - The arrival routine should be the same each day. These predictable routines will reduce separation anxiety and will allow your child to gain independence and practice responsibility.
  - If your child is having trouble separating from you, signal the teacher and let her take care of it. A quick "good-bye" and exit from the parent is best. Please trust that the teacher will handle your child appropriately in an event such as this.
  - Preschool parents are expected to come to the exterior door of the school building each time they drop off and pick up their child. Preschool students are not allowed to walk through the parking lot without an adult.
- **Pick Up**
  - Families must pick up their child at 3:00pm from the preschool classroom.
  - You will be required to provide a listing of the people you authorize the school to release your child to. Your child will never be released to someone not on the list unless we receive a note or phone call from parents. If the staff does not know the person, he or she will be asked to show identification. Please let the office know if there will be any changes made to your child's daily drop-off or pick-up routine.

**BATHROOM ISSUES** - Potty training is an important time in a child's development. For children who are unable to use the toilet consistently, the following procedures are in place:

- Diapering be done in the designated diaper area (in student bathrooms).
- Staff will check children for signs of a soiled diaper or pull up at least every two hours.
- At all times, staff will have a hand on the students if being changed on an elevated surface.
- Surfaces involved in diapering will be sanitized after each use.
- Potty chairs will not be used due to the risk of spreading infectious diseases unless it is a student's specific goal according to his/her IEP.

**BIRTHDAYS** - We recognize birthdays are a significant event in children's lives. Children may bring treats in to celebrate their birthday. If the treats are edible, they must follow the "Smart Snack" guidelines. Children with a summer birthday are welcome to choose a day during the school year to celebrate if they wish. Invitations to parties outside of school will not be distributed at school.

**BIRTH CERTIFICATES** - State law requires that a certified copy of a student's birth certificate be used when enrolling a new student in school. If your child is registering with Raymond Central Public Schools for the first time, you may obtain this document from the Bureau of Vital Statistics in the state in which your child was born. Assistance in obtaining birth certificates may be obtained from Health Records Management, PO Box 95065, Lincoln, NE 68509-5065. There is a fee per certificate.

Please note: The document parents receive from the hospital looks like a birth certificate, but it is not a certified copy. A certified copy has the raised seal of the State of Nebraska on it and is signed by the director of vital statistics.

If a birth certificate is unavailable, other reliable proof of a student's identity may be used. These documents could include naturalization or immigration documents showing date of birth or official hospital birth records, a passport, or a translation of a birth certificate from another country. The documents must be accompanied by an affidavit explaining the inability to produce a copy of the birth certificate.

**CALENDAR** - Preschool has their own calendar that is designed to meet the needs according to Rule 11 and the needs of the preschool program. Any changes to the calendar will be communicated with parents throughout the year.

**CHILD ASSESSMENT** - It is the preschool program's belief that assessment of young children should be purposeful, developmentally appropriate, and take place in the natural setting by familiar adults. These results will be used for planning experiences for the children and to guide instruction.

Teaching Strategies GOLD online creates a developmental profile for each child based on teacher observations and checklists. Teacher Strategies GOLD is based on 38 research based objectives that include predictors of school success and are aligned with the Common Core State Standards and state early learning guidelines.

Information gathered from assessment is used in the following ways:

- To provide information about children's needs, interests, and abilities in order to intentionally plan developmentally appropriate experiences and instruction
- To provide information to parents about their child's developmental milestone and progress
- To indicate possible areas that require additional assessment

If, through observation or data collected, the teacher feels that there is a possible concern related to a developmental delay or other special need, she/he will communicate this to the family during a conference, sharing documentation of concern. Suggestions for next steps may include the following, with the knowledge and consent of the parents:

- The teacher requests assistance from the ESU2 team
- A request for special education evaluation can be made

The preschool teacher would assist in arranging for developmental screening and referral for diagnostic assessment when indicated. The family is encouraged to advocate for services for their child and be actively involved in the eligibility process.

If a child is determined to need special accommodations or modifications by the preschool team, those accommodations/modifications occur within the materials, environment, and lesson plans for that child. Examples include sign language and visuals, behavior plans, etc.

**CHILD PROTECTION POLICIES** - The health and wellbeing of every child is of the utmost importance, and protection of children is our responsibility. The program has a written school board policy for reporting child abuse and neglect as well as procedures in place that comply with applicable federal, state, and local laws. Staff who report suspicions of child abuse or neglect where they work are immune from discharge or other disciplinary actions. All teaching staff completes “Mandatory Reporter: Child and Dependent Adult Abuse” at least every five years.

**CLASS SIZE** - The Raymond Central Public School District values a proper student:adult ratio. Each classroom which serves early childhood students receiving services has a teacher who is certified in Early Childhood Education and Early Childhood Special Education. Each classroom also employs additional adult staff to aid in the education process.

We wish we could enroll every child, but our program does have a capacity based on class size enrollment. A quality early childhood program keeps the teacher:pupil ratio low and matches enrollment to the physical size of the facility.

### **CLOTHING**

- Children should wear **comfortable play clothes** with simple fastenings and comfortable, soft-soled shoes.
- Children will **play outside everyday** unless there is inclement weather or if the wind chill is 15 degrees or lower. Please send appropriate clothing for the weather.
- Children should keep a **complete set of clothing** at school in case of accidents.
- Label all clothing items with child’s name.
- Check your child’s school backpack regularly for possible soiled clothing.
- Clothing should follow school age guidelines for appropriateness.

**COMMUNICATION** - The preschool program prompts positive communication between families and staff by written notes, classroom technology pages, emails, phone calls, home visits, parent teacher conferences, and in person meetings. Parents are encouraged to maintain regular, on-going, two-way communication with the teacher.

Raymond Central Preschool invites families to be involved in one or all of the following ways:

- Support your child by keeping the teacher informed of changes and events that might affect your child (i.e. family death, moving homes, etc.)
- Attend family meetings
- Check your child's daily folder
- Attend Parent Teacher Conferences
- Attend and/or help with special events

**CONTACTING THE TEACHER** - If there is anything you need to know about a situation involving your child, the teacher will provide this information to you through a brief conversation at pick-up time, via a phone call, email, or a short note. This would include things like minor injury (more than a band-aid), behavior issues, concerns with a situation, etc. Please don't hesitate to let your child's teacher know of any concerns, questions, or confusion over anything. If you wish to visit with the teacher in depth, it would be best to set up a conference or call when preschool is not in session.

**DAILY SCHEDULE** - A consistent daily schedule is planned to offer a balance of learning activities. Learning is both formal and informal. Play is planned for every day. Children will have the opportunity for the following types of activities every day:

- Large and Small Group Activities
- Self-directed Play
- Learning Center Activities: Art, Science, Writing, Book Center, Blocks, Pretend/Dramatic Play, Sensory play, and more
- Story Time
- Individual Activities
- Outdoor Activities
- Music and Movement

**DISCIPLINE (Permissible Methods)** - For acts of aggression and fighting (biting, scratching, hitting), staff will set appropriate expectations for children and guide them in problem solving problems. Positive guidance will be the technique for managing children with challenging behaviors rather than punishing them for having problems they have not yet learned to solve.

**DISTRICT WEBSITE** - District information can be found in the monthly district newsletter or the school's webpage at <http://www.rcentral.org>.

**EARLY CHILDHOOD ADVISORY COMMITTEE** - At Raymond Central Preschool, we believe it is important to have a cooperative partnership with our parents and the community to ensure continued development and expansion of our preschool program. Through this committee, we hope to develop recommendations to the Board of Education and provide information to the public and future parents regarding the rules and expectations of our preschool program.

Parents will be asked by their child's teacher to participate in the Early Childhood Advisory Committee. We strive to have a variety of students and parents represented including, but not limited to stay at home parents and working parents, students with identified needs and students meeting age appropriate milestones, etc.

**ENROLLMENT POLICY** - Enrollment procedures used to determine the preschool class list are based on the following list of criteria in order of priority:

- 1) Child on an Individualized Education Plan (IEP) or Individualized Family Service Plan (IFSP), living in our school district will have first priority for acceptance. The State of Nebraska set up the preschool program to help those children with the highest needs.
- 2) Those students living in our school district who will turn four by July 31, based on when application was received.
- 3) Those students living in our school district who will turn three by July 31, based on when application was received.
- 4) If there are still available spots, non-district students will be chosen with priority given to staff children and those who have siblings enrolled in the district.
- 5) If a child who does not reside in our district qualifies for an IEP after being enrolled in our program, we will allow them to finish the year. Subsequent year placement is not guaranteed and is based on option enrollment policies.

**EMERGENCY DRILLS** - Regular emergency fire, tornado, and lockdown drills are conducted throughout the year. All students, staff, and visitors are expected to take part in the drills.

**FIRST AID KIT** - Our First Aid Kit is not accessible to children, but readily available to use. It is fully equipped. Following each use of the First Aid Kit, the contents will be inspected and missing items will be replaced.

**FAMILY** - Families play the central role in their child's development. Engaging families into their child's preschool experience is essential to maximize learning. We will strive to actively partner with parents and guardians. There will be many opportunities for families to work with their preschoolers throughout the year.

**HAND WASHING PRACTICES** - Frequent hand washing is important toward preventing the spread of infectious diseases. Teachers will teach children how to wash their hands effectively.

Children and adults wash their hands:

- Upon arrival each day
- After diapering or using the toilet
- After handling bodily fluids (i.e. wiping a nose, coughing on a hand, etc.)
- Before meals and snacks
- After handling animals

**HOME VISITS** - Home visits are held twice a year. The first home visit is made prior to the start of the school year. This is an opportunity for the preschool teacher to get to know you, your child, and your family, and begin to create a partnership between home and school. It allows your child to become familiar with his/her teacher and answer any questions you may have. This is a time to share how you prefer to communicate with your child's teacher, family interests, any concerns you may have, and what goals you have for your child.

The second home visit is held in the spring in conjunction with Parent Teacher Conferences.

**ILLNESSES** - If a child becomes ill during class time, we will notify parents that the student needs to be sent home. Conditions requiring a student be sent home include: Temperature greater than 100°F, vomiting, diarrhea, unexplained rashes, live head lice, or on determination by the school nurse that the child's condition prevents meaningful participation in the educational program, presents a health risk to the child or others, or that medical consultation is warranted unless the condition resolves. Please include emergency daytime phone numbers on your child's registration information so that you can be reached if your child becomes ill or injured while at school. If your child experiences any of the above conditions or symptoms, please keep them home from Preschool and notify the office of their absence. A child should stay home for at least 24 hours after the last symptom is seen. Some illnesses may require a doctor's note upon returning to school.

**IMMUNIZATIONS** - State law requires that students age 2 through 5 years enrolled in a school based program not licensed as child care provider have the following immunization prior to attending:

- 4 doses of Dtap, or DT vaccine
- 3 doses of Polio vaccine
- 3 doses of Hib vaccine or 1 doses of Hib given at or after 15 months of age
- 3 doses of pediatric Hepatitis B vaccine
- 1 dose of MMR or MMRV given on or after 12 months of age
- 4 doses of pneumococcal or 1 dose of pneumococcal given on or after 15 months of age

You must show proof of immunization(s) upon enrollment in school. Any student who does not comply with the immunization requirements will not be allowed to continue in school. Students with medical conditions or personal beliefs that do not allow immunizations may complete a waiver statement which is held in the elementary office.

**INCLUSION** - The preschool program serves all children, including those with disabilities and unique learning needs. Modifications are made in the environment and staffing patterns in order to include children with special needs. Staff are aware of the identified needs of individual children and are trained to follow through on specific intervention plans. It is our belief that inclusion in our program will enrich the experience for the teachers, students, other children and their families.

**LATE REGISTRATION** - Families who would like to register their child after the beginning of the school year are welcome to do so, provided there are still openings available. If no openings are available, the student will be placed on a waiting list and the family will be contacted as openings occur.

**LUNCH/SNACK** - Students may bring their lunch or participate in the hot lunch program. Lunch will be provided at 11:00 a.m. We serve our lunch "Family Style." This means preschoolers will be able to set the table, use child-sized serving utensils to serve themselves food, pass the dish to classmates sitting next to them, and pour their own beverage from a child-sized pitcher. Lunch is not included in the monthly tuition fee; however, we highly encourage all students to eat school lunch.

- Student Lunch - \$2.75 per day
- Milk only (with cold lunch) - \$0.50 per day
- Reduced Price Lunch - \$0.40 per day
- Free Lunch - No Cost

Forms are available for verification and participation in the Federal Free and Reduced Lunch Program at both the elementary office and online. Questions about this program should be directed to the Superintendent's Office at (402) 785-2615.

Snacks will be provided to all preschool children and are included in the monthly fee.

Food brought from home:

- The teacher will provide families a list of foods meeting the "Smart Snack" guidelines
- Food requiring refrigeration will be refrigerated until served
- Food that comes from home for sharing among children must be either whole fruits or prepackaged foods in factory sealed containers

For children with special health care needs, food allergies, or special nutrition, the child's health care provider should provide the program with an individualized care plan. Children with food allergies shall be protected from contact with the problem food.

Raymond Central Preschool does not use food or beverage as reward for academic performance or good behavior. Likewise, food or beverages will not be withheld as a punishment.

**OPEN HOUSE** - Prior to the first day of school, families are invited to attend an Open House.

The purpose of Open House includes:

- Allowing the child to see the preschool classroom
- Staff can answer any questions
- Family can bring their child's school supplies

**OUTDOOR PLAY** - We are outdoors daily as weather permits. This allows children to develop their gross motor skills, get exercise, and be active. If the "feels like temperature" is 15 or above, we will be going outside. If the conditions prevent us from going outdoors, alternative gross motor activities will be offered indoors.

It is important to dress your child according to the weather. When it is cold outside, children need a warm coat, mittens or gloves, and a hat. For warmer weather, dress your children in light, breathable clothing. For inbetween weather days, dress your child in layers. It is expected that all children go outside unless there is a doctor's note stating a reason why the child cannot go outside.

**PARENT-TEACHER CONFERENCES** - Parent Teacher Conferences are held twice a year, fall and spring. During the conference, the teacher will share results of classroom assessments and samples of your child's work. Conferences will allow you the opportunity to share any progress you have seen from your child and ask any questions you may have.

**PERSONAL POSSESSIONS** - We do not allow toys to be brought from home. If your child brings an item from home, it will need to remain in his/her backpack. Please do not allow children to bring gum, candy, money, toy guns, etc. to school unless requested by the classroom staff. RC Preschool is not responsible for lost or broken toys brought from home.

**PICTURES AND VIDEOS** - Pictures and videos of our students, activities, and classroom will be taken and used for various learning opportunities. These same pictures are positive additions to articles posted on the district website, in the classroom newsletter, or submitted to the local paper.

**SCHOOL CLOSINGS** - The Superintendent may close school in case of severe weather. In the event of inclement weather, school cancellations will be broadcasted on local television channels. All families with children enrolled in Raymond Central Public Schools will be enrolled in the School Closing Notification System.

- The School will use the phone number given on the child's preschool forms.
- Families should notify the school if their phone number changes or if they want the call to go to a different number.

**SCHOOL HEALTH SCREENING** - Children in Preschool are screened for vision, hearing, dental defects, height and weight. Parents who do not wish their child to participate in the school screening program must communicate this in writing to the school health office where their child attends at the start of the school year. Because Nebraska statutes require school-age screening, parents who remove their child from the screening program must submit findings from an alternate medical provider to the school by December 1.

**STUDENT BEHAVIOR** - Teaching staff will equitably use positive guidance, redirection, and planning ahead to prevent problems. They will encourage appropriate behavior through the use of consistent clear rules and involving children in problem solving to foster the child's own ability to become self-disciplined. When the child understands words, discipline will be explained to the child before and at the time of any disciplinary action. Teaching staff will encourage children to respect other people, to be fair, respect property, and learn to be responsible for their actions. Teaching staff will use discipline that is consistent, clear, and understandable to the child. They will help children learn to persist when frustrated, play cooperatively with other children, use language to communicate needs, and learn turn taking.

The teaching staff in the preschool is highly trained, responsive, respectful, and purposeful. The teachers anticipate and take steps to prevent potential challenging behaviors. They evaluate and change their responses based on individual needs. When children have challenging behaviors, teachers promote prosocial behavior by:

- Interacting in a respectful manner with all children
- Modeling turn taking and sharing as well as caring behaviors
- Helping children negotiate their interactions with one another and with shared materials
- Engaging children in the care of their classroom and ensuring that each child has an opportunity to contribute to the group
- Encouraging children to listen to one another and helping them to provide comfort when others are sad or distressed

Teaching staff will guide children to develop self-control and orderly conduct in relationship to peers and adults. Children will be taught social, communication, and emotional regulation skills. If a child displays persistent, serious, and challenging behavior, the teaching staff, parents, and ESU support staff will work as a team to develop and implement an individualized plan that supports the child's inclusion and success.

Aggressive physical behavior toward staff or children is unacceptable. Teaching staff will intervene immediately when a child becomes physically aggressive to protect all of the children and encourage more acceptable behavior.

**SUPPORT SERVICES**

- The school psychologist provides assessment, consultation, and counseling services to meet the academic and behavioral needs of students.
- Parents will be contacted any time school psychological services are offered to a student in an individual or small group setting.
- Additionally, the school psychologist is part of the student support staff that assists teachers in planning classroom instruction and monitoring its effectiveness.
- This includes but is not limited to consultation with teachers and parents, classroom observations, student progress monitoring, and collaboration with administrators regarding curriculum and instruction.
- These services are provided for the benefit of all students and offered as part of general education services.

**TRANSPORTATION** - Resident children who are identified with a disability and are receiving early childhood services have the option to receive transportation that is provided by the district; however, a few guidelines will be discussed with families.

If your child is not identified with a disability, then transportation will be determined based on the following criteria:

- Whether there is available space on the preschool bus.
- Four-year-old resident students enrolled in the 4-year-old preschool program will be given first consideration and the preschool bus will pick-up and drop-off only from state licensed childcare centers.
- The district reserves the right to eliminate services to students who are not identified with a disability at any time based on bus capacity limitations.

If transportation is not provided by the district, parents are required to make transportation arrangements for their child to get to and from preschool on a regular basis and in a timely manner.

**TUITION** - It is our goal to provide quality, affordable early childhood experiences for all children. The Raymond Central Preschool adheres to the Rule 11 guidelines put forth by the Nebraska Department of Education and works in cooperation with the NDE to establish a fee schedule and guidelines for all preschool families.

Tuition costs for the 2024-2025 school year are as follows:

Full Tuition	\$100 per month for 9 months (September-May) or \$900 per year
Reduced Meal Program Eligibility	\$50 per month for 9 months (September-May) or \$450 per year
Free Meal Program Eligibility	No Cost
Special Education (IEP)	No Cost

Payment is due prior to the 1<sup>st</sup> of every month. Parents/guardians can send a check with their child or payments can be made online.

The monthly fee will include preschool tuition and a snack. Lunch is not included in this fee.

**NOTICE OF NONDISCRIMINATION** - The Raymond Central Public School District does not discriminate on the basis of sex, disability, race (including skin color, hair texture and protective hairstyles), color, religion, veteran status, national or ethnic origin, age, marital status, pregnancy, childbirth or related medical condition, sexual orientation or gender identity, or other protected status in its programs and activities and provides equal access to the Boy Scouts and other designated youth groups. The following persons have been designated to handle inquiries regarding the non-discrimination policies:

Students: Building Principals

Employees and Others: Superintendent

Complaints or concerns involving discrimination or needs for accommodation or access should be addressed to the appropriate Coordinator. For further information about anti-discrimination laws and regulations, or to file a complaint of discrimination with the OCR at One Petticoat Lane, 1010 Walnut Street, 3rd Floor, Suite 320, Kansas City, Missouri 64106, (816) 268-0550 (voice), Fax (816) 268-0599, (800) 877-8339 (telecommunications device for the deaf), or [ocr.kansascity@ed.gov](mailto:ocr.kansascity@ed.gov).



**Raymond Central Public Schools  
Preschool Handbook Parent Form**

Please sign below and return with your child

YES	NO	
		I have reviewed and agree to follow the rules and regulations as defined in the Raymond Central Public Schools Preschool Handbook.
		I give permission for my child to be photographed or videotaped at preschool for use in the classroom, for publication in the media, or for other professional use to promote Raymond Central Public Schools.
		I give permission for my child to accompany his/her preschool class on field trips, walking or school van.
		I allow my child to use the Internet with supervision of staff members.

\_\_\_\_\_  
(Parent/Guardian Name Printed)

\_\_\_\_\_  
(Student Name)

\_\_\_\_\_  
(Parent/Guardian Signature)

\_\_\_\_\_  
(Date)

Discuss, Consider and Take Necessary Action to approve the purchase of masts, backboards, shot clock, safety straps for the competition gym

Motion by Burklund, second by Benes to approve the purchase of masts, backboards, shot clock, and safety straps for the competition gym at a cost of \$15,283.08. RCV 4-0. Motion carried.



Estimate Number <b>140972</b>
----------------------------------

**Main Showroom**  
 1605 N 9th St  
 Indianola, IA 50125  
**Phone:** (515) 961-7300  
 www.phillipsfloors.com

Type: Material and Labor  
 Date: 01/23/2024  
 Expires on: 2/22/2024  
 Payment Term: Net 30  
 Sales Rep.: Steve Putney  
 Email: putneys@phillips-commercial.com

**Customer Information**

<b>Company Name:</b> Raymond Central High School <b>Customer Name:</b> Tony Kobza <b>Address:</b> 1800 West Agnew Road, Valparaiso, NE 68065 <b>Email:</b> Tony.kobza@rcentral.org <b>Cell Phone:</b> (402) 641-1509
----------------------------------------------------------------------------------------------------------------------------------------------------------------------------------------------------------------------------------

**Service Site Details**

<b>Contact Name:</b> Tony Kobza <b>Address:</b> 1800 West Agnew Road, Valparaiso, NE 68065 <b>Email:</b> Tony.kobza@rcentral.org <b>Cell Phone:</b> (402) 641-1509
-----------------------------------------------------------------------------------------------------------------------------------------------------------------------------

Item	Description/Area	Amount
Replace 2 Main Hoops	We will tear out and dispose of all old steel. We will deliver and install the 2 new hoops. We will re use the 3 1/2 pipe attached to the trusses. this will take approximately 1 week to complete.	\$15,283.08
	<b>Total</b>	<b>\$15,283.08</b>
	<b>Grand Total</b>	<b>\$15,283.08</b>

Print PDF Revise Approve

Arial13OK

Consider, Discuss and Take Necessary Action to approve the purchase of our annual student/staff computer cycle

Motion by Lange, second by Burklund to approve the purchase of our annual cycle of student/staff computers (180 student computers/20 teacher computers) at a cost of \$85,662. RCV 4-0. Motion carried.

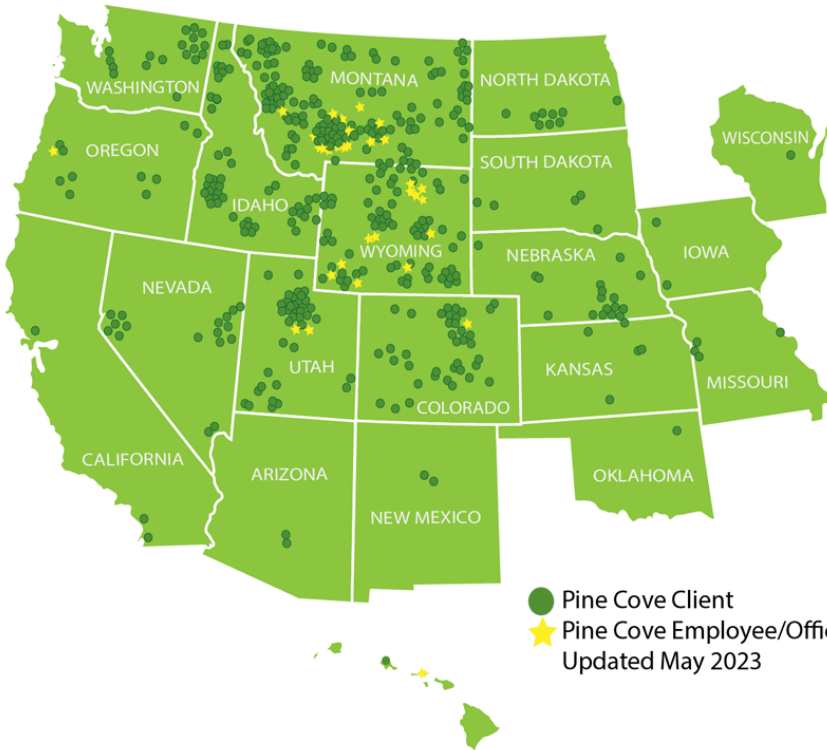

**pine:cove**  
CONSULTING

**Trusted IT Solutions  
Since 1993**

**CYBERSECURITY | NETWORKING | COMMUNICATION  
| PHYSICAL SECURITY | MANAGED SERVICES | STUDENT SAFETY |**

**We have prepared a quote for you:**

**Devices**



Quote # 009073  
Version 2

**Prepared for:**

**Raymond Central Public  
Schools**

Lynn Johnson  
lynn.johnson@rcentral.org

Devices

Description	Price	Qty	Ext. Price
<b>Lenovo 500e G4 - Intel N100 (0.80GHz) - 12.2 1920 x 1200 Touch Display - Chrome OS - 4.0GB - 1x32GB eMMC 5.1 TLC - Intel UHD Graphics - BT 5.1 or above - Wi-Fi 6E AX211 - 720P HD RGB - 3 Cell Li-Pol 47Wh - 1 Year Mail-in</b> 	\$417.53	180	\$75,155.40
<b>Lenovo 500e G4 - Intel N100 (0.80GHz) - 12.2 1920 x 1200 Touch Display - Chrome OS - 4.0GB - 1x32GB eMMC 5.1 TLC - Intel UHD Graphics - BT 5.1 or above - Wi-Fi 6E AX211 - 720P HD RGB - 3 Cell Li-Pol 47Wh - 1 Year Mail-in</b> 	\$389.63	180	\$70,133.40
<b>Shipping, Handling and Insurance</b>	\$145.57	1	\$145.57
<b>LENOVO:ThinkBook 16 G6 IRL - Intel - Core i7 - 1355U - 16Inch - 10-Point Multi-Touch - 1920 x 1200 - DDR5 - 16GB RAM - 512GB SSD - No Optical Storage - Intel Iris Xe - Power Adapter - 65Watt - Microsoft Windows 11 Professional - Gigabit Ethernet, Wi-Fi, B</b>	\$955.47	20	\$19,109.40
<b>LENOVO:ThinkBook 16 G6 ABP - AMD - AMD Ryzen 7 - 7730U - 2GHz - 16Inch - 10-Point Multi-Touch - 1920 x 1200 - DDR4 - 16GB RAM - 512GB SSD - No Optical Storage - AMD Radeon Graphics - Power Adapter - 65Watt - Microsoft Windows 11 Professional - Gigabit Eth</b>	\$880.62	20	\$17,612.40

**Subtotal: \$182,156.17**

## Devices

### Prepared by:

**Pine Cove Consulting**

sales@pinecc.com  
800-432-0346

### Prepared for:

**Raymond Central Public Schools**

1800 W. Agnew Road  
Raymond, NE 68428  
Lynn Johnson  
(402) 785-2615  
lynn.johnson@rcentral.org

### Quote Information:

**Quote #: 009073**

Version: 2  
Delivery Date: 01/16/2024  
Expiration Date: 02/08/2024

---

## Quote Summary

Description	Amount
Devices	\$182,156.17
<b>Total:</b>	<b>\$182,156.17</b>

This proposal shall not be used for the creation of RFP/RFQ documents, by the customer.

TERMS: Due on receipt of invoice.

Access to the customer portal for online payment is @ <https://pinecc.connectboosterportal.com>

Applicable fees and taxes not included.

<https://www.orderporter.com/OrderPorter/online.order?passcode=54fcddc04bd573fb1ac95c3165d0281b&entrykey=Quosal Branded v3>  
(copy)



COMPUTER  
HARDWARE



# QUOTE

235 S. 70th St.  
Suite #101  
Lincoln, NE 68510

L188063

02/02/24

PAGE: 001

SALESPERSON	PURCHASE ORDER#	REFERENCE#	SHIPPER:
AUSTIN L GLOVER			

**BILLED TO:**  
 RAYMOND CENTRAL PUBLIC SCHOOLS  
 JAXN KOBZA  
 1800 W AGNEW ROAD  
 RAYMOND, NE 68428

**SHIPPED TO:**  
 RAYMOND CENTRAL PUBLIC SCHOOLS  
 1800 W AGNEW ROAD  
 RAYMOND, NE 68428

ITEM NUMBER	ITEM DESCRIPTION	QTY	PRICE	EXTENDED PRICE
001 82W40009US	LENOVO 500E YOGA GEN 4 CHROMEBOOK N100 4GB 32GB 12.2IN TOUCHSCREEN	180	\$336.85	\$60,633.00
002 CROSSWDISEDUNEW	GOOGLE CHROME OS MGT LIC+S EDU	180	\$31.50	\$5,670.00
003	21KK000EUS LENOVO THINKBOOK 16 GEN 6 RYZEN 7 7730U 16INCH TOUCHSCREEN 16GB 512GB WINDOWS 11 PRO	20	\$813.20	\$16,264.00
004 5WS0A23681	LENOVO 3 YEAR WARRANTY	20	\$76.25	\$1,525.00
005 5PS0L30075	LENOVO 3YR ADP	20	\$78.50	\$1,570.00

Quote Good Up Through: 03/09/24

<b>SUBTOTAL:</b>	\$85,662.00
<b>SHIPPING:</b>	\$0.00
<b>HANDLING:</b>	\$0.00
<b>OTHER CHARGES:</b>	\$0.00
<b>TAX:</b>	\$0.00
<b>TOTAL:</b>	<u><u>\$85,662.00</u></u>



Thank you for choosing CDW. We have received your quote.

Hardware    Software    Services    IT Solutions    Brands    Research Hub

# QUOTE CONFIRMATION

JAXN KOBZA,

Thank you for considering CDW•G for your technology needs. The details of your quote are below. **If you are an eProcurement or single sign on customer, please log into your system to access the CDW site.** You can search for your quote to retrieve and transfer back into your system for processing.

For all other customers, click below to convert your quote to an order.

**Convert Quote to Order**

QUOTE #	QUOTE DATE	QUOTE REFERENCE	CUSTOMER #	GRAND TOTAL
NSMH906	1/30/2024	NSMH906	2356027	<b>\$18,044.20</b>

QUOTE DETAILS				
ITEM	QTY	CDW#	UNIT PRICE	EXT. PRICE
<a href="#">LVO TB 16 G6 I7-1355U 512 16 W11P</a>	20	7691842	\$902.21	\$18,044.20
Mfg. Part#: 21KH000FUS Contract: MARKET				

<b>SUBTOTAL</b>	\$18,044.20
<b>SHIPPING</b>	\$0.00
<b>SALES TAX</b>	\$0.00
<b>GRAND TOTAL</b>	<b>\$18,044.20</b>

PURCHASER BILLING INFO	DELIVER TO
<b>Billing Address:</b> RAYMOND PUBLIC SCHOOLS ACCOUNT PAYABLE 1800 W AGNEW RD RAYMOND, NE 68428-4315 <b>Phone:</b> (402) 785-2685 <b>Payment Terms:</b> NET 30 Days-Govt/Ed	<b>Shipping Address:</b> RAYMOND PUBLIC SCHOOLS JAXN KOBZA 1800 W AGNEW RD RAYMOND, NE 68428-4315 <b>Phone:</b> (402) 785-2685 <b>Shipping Method:</b>
	<b>Please remit payments to:</b> CDW Government 75 Remittance Drive Suite 1515 Chicago, IL 60675-1515



### Sales Contact Info

Dan Behnke | (877) 325-6415 | [danbehn@cdwg.com](mailto:danbehn@cdwg.com)

LEASE OPTIONS			
FMV TOTAL	FMV LEASE OPTION	BO TOTAL	BO LEASE OPTION

<b>\$18,044.20</b>	<b>\$494.23/Month</b>	<b>\$18,044.20</b>	<b>\$568.03/Month</b>
--------------------	-----------------------	--------------------	-----------------------

Monthly payment based on 36 month lease. Other terms and options are available. Contact your Account Manager for details. Payment quoted is subject to change.

Why finance?

- Lower Upfront Costs. Get the products you need without impacting cash flow. Preserve your working capital and existing credit line.
- Flexible Payment Terms. 100% financing with no money down, payment deferrals and payment schedules that match your company's business cycles.
- Predictable, Low Monthly Payments. Pay over time. Lease payments are fixed and can be tailored to your budget levels or revenue streams.
- Technology Refresh. Keep current technology with minimal financial impact or risk. Add-on or upgrade during the lease term and choose to return or purchase the equipment at end of lease.
- Bundle Costs. You can combine hardware, software, and services into a single transaction and pay for your software licenses over time! We know your challenges and understand the need for flexibility.

General Terms and Conditions:

This quote is not legally binding and is for discussion purposes only. The rates are estimate only and are based on a collection of industry data from numerous sources. All rates and financial quotes are subject to final review, approval, and documentation by our leasing partners. Payments above exclude all applicable taxes. Financing is subject to credit approval and review of final equipment and services configuration. Fair Market Value leases are structured with the assumption that the equipment has a residual value at the end of the lease term.

Need Help?



My Account



Support



Call 800.800.4239

[About Us](#) | [Privacy Policy](#) | [Terms and Conditions](#)

This order is subject to CDW's Terms and Conditions of Sales and Service Projects at <http://www.cdw.com/content/terms-conditions/product-sales.aspx>  
For more information, contact a CDW account manager.

© 2024 CDW•G LLC, 200 N. Milwaukee Avenue, Vernon Hills, IL 60061 | 800.808.4239



Thank you for choosing CDW. We have received your quote.

Hardware    Software    Services    IT Solutions    Brands    Research Hub

# QUOTE CONFIRMATION

JAXN KOBZA,

Thank you for considering CDW•G for your technology needs. The details of your quote are below. **If you are an eProcurement or single sign on customer, please log into your system to access the CDW site.** You can search for your quote to retrieve and transfer back into your system for processing.

For all other customers, click below to convert your quote to an order.

**Convert Quote to Order**

QUOTE #	QUOTE DATE	QUOTE REFERENCE	CUSTOMER #	GRAND TOTAL
NSLS203	1/30/2024	NSLS203	2356027	<b>\$66,709.80</b>

QUOTE DETAILS				
ITEM	QTY	CDW#	UNIT PRICE	EXT. PRICE
<a href="#">Lenovo 500e Yoga Chromebook Gen 4 - 12.2" - Intel N-series - N100 - 4 GB RA</a> Mfg. Part#: 82W40009US Contract: USETPA 2108001 IT Equipment and Services (2108001)	180	7407954	\$339.61	\$61,129.80
<a href="#">Google Chrome Education Upgrade</a> Mfg. Part#: CROS-SW-DIS-EDU-NEW Electronic distribution - NO MEDIA Contract: USETPA 2108001 IT Equipment and Services (2108001)	180	5988499	\$31.00	\$5,580.00

<b>SUBTOTAL</b>	\$66,709.80
<b>SHIPPING</b>	\$0.00
<b>SALES TAX</b>	\$0.00
<b>GRAND TOTAL</b>	<b>\$66,709.80</b>

PURCHASER BILLING INFO	DELIVER TO
<b>Billing Address:</b> RAYMOND PUBLIC SCHOOLS ACCOUNT PAYABLE 1800 W AGNEW RD RAYMOND, NE 68428-4315 <b>Phone:</b> (402) 785-2685 <b>Payment Terms:</b> NET 30 Days-Govt/Ed	<b>Shipping Address:</b> RAYMOND PUBLIC SCHOOLS JAXN KOBZA 1800 W AGNEW RD RAYMOND, NE 68428-4315 <b>Phone:</b> (402) 785-2685 <b>Shipping Method:</b> UPS Freight LTL, Special Services
	<b>Please remit payments to:</b>  CDW Government 75 Remittance Drive Suite 1515 Chicago, IL 60675-1515



## Sales Contact Info

Dan Behnke | (877) 325-6415 | [danbehn@cdwg.com](mailto:danbehn@cdwg.com)

LEASE OPTIONS			
FMV TOTAL	FMV LEASE OPTION	BO TOTAL	BO LEASE OPTION
\$66,709.80	\$1,788.49/Month	\$66,709.80	\$2,066.00/Month

Monthly payment based on 36 month lease. Other terms and options are available. Contact your Account Manager for details. Payment quoted is subject to change.

Why finance?

- Lower Upfront Costs. Get the products you need without impacting cash flow. Preserve your working capital and existing credit line.
- Flexible Payment Terms. 100% financing with no money down, payment deferrals and payment schedules that match your company's business cycles.
- Predictable, Low Monthly Payments. Pay over time. Lease payments are fixed and can be tailored to your budget levels or revenue streams.
- Technology Refresh. Keep current technology with minimal financial impact or risk. Add-on or upgrade during the lease term and choose to return or purchase the equipment at end of lease.
- Bundle Costs. You can combine hardware, software, and services into a single transaction and pay for your software licenses over time! We know your challenges and understand the need for flexibility.

General Terms and Conditions:

This quote is not legally binding and is for discussion purposes only. The rates are estimate only and are based on a collection of industry data from numerous sources. All rates and financial quotes are subject to final review, approval, and documentation by our leasing partners. Payments above exclude all applicable taxes. Financing is subject to credit approval and review of final equipment and services configuration. Fair Market Value leases are structured with the assumption that the equipment has a residual value at the end of the lease term.

## Need Help?



My Account



Support



Call 800.800.4239

[About Us](#) | [Privacy Policy](#) | [Terms and Conditions](#)

This order is subject to CDW's Terms and Conditions of Sales and Service Projects at <http://www.cdw.com/content/terms-conditions/product-sales.aspx>

For more information, contact a CDW account manager.

© 2024 CDW•G LLC, 200 N. Milwaukee Avenue, Vernon Hills, IL 60061 | 800.808.4239

### Next Regular Board Meeting

The next regular Board of Education Meeting will be held Wednesday, March 13, 2024.

### Adjournment

Motion by Breitreutz, second by Benes to adjourn the meeting at 7:05 PM. RCV 4-0. Motion carried.