

City of St. Paul Regular Meeting

Monday, August 12, 2019 12:00 PM

704 6th Street

St. Paul, NE 68873

1. A meeting of the St. Planning and Zoning Commission was convened in open and public session on the 12th day of August, 2019 at 12:00 p.m. (noon) held in the City Council Chambers, 704 6th Street, St. Paul, Nebraska.
2. Chairman Charles Schmid called the meeting to order at ___ p.m. with a statement regarding the Open Meeting Act, which is posted on the west wall of the City Council Chambers. Member roll call: Chairman Chuck Schmid, Arvilla Jacobs, Tony Walch, and Connie Becker, along with Zoning Administrator Matt Helzer and Laura Berthelsen (minutes). Absent: Wilber Medbery. The agenda was sent to the Board members prior to the meeting and posted in four (4) public places.
3. Discuss - Approve / Deny the July 29, 2019 minutes.
4. Chairman Schmid presented the following zoning permits:
 - (a) 2019-45 - Stephanie Holdsworth - install fence at 1217 Elm Street
 - (b) 2019-46 - Brian & Catey Sack - install fence at 1104 7th Street
 - (c) 2019-47 - Bill & Karen Northup - install fence at 922 Indian Street
 - (d) 2019-48 - Levander's Body Shop - Construct building at 321 Elm Street
 - (e) 2019-49 - Glenn Jares - Construct gazebo at 422 6th Street
 - (f) 2019-50 - Douglas & Pamela Ackles - Construction of handicap accessible ramp at 1705 Custer Street
 - (g) 2019-51 - Margaret Thompson - Demolition of barn at 1604 Paul Street
5. Discuss - Approve / Deny administrative subdivision for Rice's Subdivision
6. Discussion / Reports
7. Chairman Schmid announcing the next Planning Commission meeting
8. Public Comments
9. Zoning Administrator Helzer Report

10. Adjournment

Date

Mayor Joel M. Bergman

City Clerk Connie Jo Beck

St. Paul Planning Commission
July 29, 2019
Meeting Minutes

A meeting of the St. Paul Planning Commission was convened in open and public session on the 29th day of July, 2019 at 7:00 p.m. in the City Council Chambers, 704 6th Street, St. Paul, Nebraska.

Chairman Chuck Schmid called the meeting to order at 7:06 p.m. with a statement regarding the Open Meeting Act, which is posted on the west wall of the City Council Chambers. The agenda was sent to the Commission members prior to the meeting and posted in four (4) public places. Commission members present: Chairman Chuck Schmid, Connie Becker, Arvilla Jacobs, and Wilber Medbery. Absent: Tony Walch. Also present Zoning Administrator Matt Helzer and Laura Berthelsen (minutes).

Commission member Medbery moved to approve the July 8, 2019 meeting minutes. Commission member Becker seconded the motion. Commission members Becker, Jacobs, Medbery, and Schmid voted aye, nays none. Motion carried 4/0.

Chairman Schmid presented the following zoning permits:

- 2019-41 Alan Babka – Install chain link fence at 411 Howard
- 2019-42 St. Mark's Lutheran Church – Install monument/business sign at 1306 Howard
- 2019-43 Dillon Paczosa – Install wood privacy fence at 404 Grant Street
- 2019-44 STS Construction – Install wood fence at 404 M Street

Commission member Jacobs moved to approve Zoning Permit applications 2019-40 through 2019-44. Commission member Medbery seconded the motion. Commission members Becker, Jacobs, Medbery, and Schmid voted aye, nays none. Motion carried 4/0.

Zoning Administrator Helzer distributed copies showing an existing sign along Highway 281. The sign identifies businesses located in the adjacent building. A new business will be opening in the building. It is intended that the business name will be added to the existing sign. The owner is asking whether a permit is necessary to place the new business name on the existing sign. After much discussion, it was determined that a permit is not necessary. The existing sign, with the new business name, still complies with the sign regulations, the sign is not located in the sight triangle of an intersection, and poses no visibility issues along the highway.

Chairman Schmid announced that the next St. Paul Planning & Zoning Commission meeting will be held on Monday, August 12, 2019 at 12:00 p.m. (noon)

Chairman Schmid adjourned the meeting at 7:32 p.m.

Sincerely,

Matthew T. Helzer
Zoning Administrator

Charles M. Schmid
Chairman

Laura Berthelsen
Planning Secretary

Zoning Classification R2 Value \$ 1500 ~~00000~~

PERMIT NUMBER 2019-45
FEE \$25.00 CASH CHECK# 1610 CC

APPLICATION FOR A FENCE PERMIT

St. Paul, Nebraska: DIRECTIONS: Fill in the following information as accurately and completely as possible. This application is not acceptable unless all required information is furnished.

Property Owner Stephanie Holdsworth Contractor American Fence Company

Address 1217 Elm Street Address 1405 N Shady Bend Rd

City, State, Zip St Paul NE 68873 Phone Number 308 395 0793

Phone Number 402 309 0135 Cell Phone

Complete Legal Description of the Property Lot 5 + E 1/2 of Lot 6, Block 13, Military Add.

Address of Fence Site 1217 Elm Street Size & Kind White vinyl 6' privacy

Replacement or New Fence: replacement

Approximately when will the construction: Start 8/17/19 Finish 8/25/19

To Whom Should the Improvements be assessed? Stephanie Holdsworth

Contact Utility Superintendent at (308) 754-4483 regarding Inspection Matt Helzer Date of visit 8-8-19
(Matt Helzer's signature)

Recommendations needed before approval:

MUST CALL DIGGERS HOTLINE @ 811 BEFORE DIGGING – CONSTRUCTION ON UTILITY EASEMENTS IS NOT PERMITTED. The above information is, to the best of my knowledge, true and accurate. It is understood and agreed that any error, misstatement or misrepresentation of fact, either with or without approval on my part, such as might, if known, cause a refusal of this application, or any alteration or change in plans made without the approval of the Zoning Administrator subsequent to the issuance of the Permit, shall constitute sufficient grounds for the revocation of such permit. This permit is valid for one (1) year from approval date.

The signature also indicates permission granted to the Zoning Administrator to inspect the site in which this permit is granted at any time until completed.

Signature of Applicant [Signature] Date 8/16/19

N
Drawing:

W

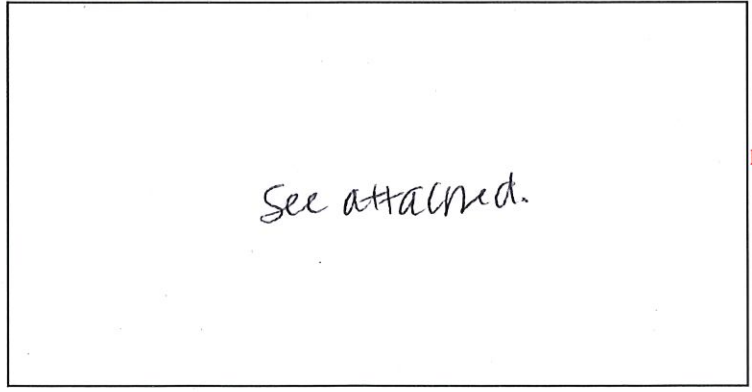

E

For Office Use Only:
Permit is Approved Denied S Date
Zoning Administrator

Reasons for Denial:

2019-45

AMERICAN FENCE COMPANY

Omaha Lincoln Des Moines Sioux Falls Grand Island Kansas City Rochester
 1605 North Shady Bend Road Office: (308) 395-0793 SALESMAN
 Grand Island, NE 68801 Email: c.hancock@americafence.com Phone: 308-379-0666

DATE	7/3/2019	PHONE:	402-309-9935	CELL:		Kingston 424@gmail.com	
CUSTOMER	Catey Sack	WORK:		SPECIFICATION FOR FENCE - RAILINGS			
PROJECT LOCATION:	1217 Elm Street			STYLE DRAWING	STYLE DRAWING		
CITY	St. Paul	STATE	NE	ZIP	K 373		
BILLING ADDRESS:				AFC JOB #	OVERALL LENGTH		
CITY		STATE	NE	ZIP	91'		
				AFC JOB #	OVERALL HEIGHT		
					6'		

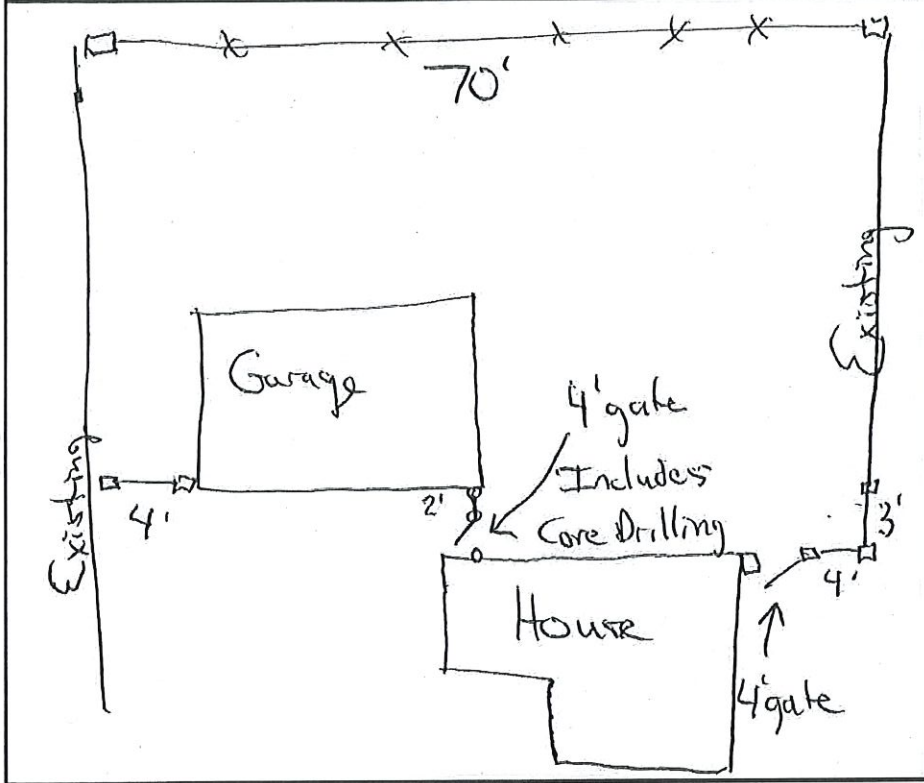

EMAIL

SPECIAL NOTES:

Materials, Labor, & Tax all included. The posts are set using concrete.

- CORNER LOT
- FRENCH GOTHIC
- REPAIR
- OVER SCALLOP
- CUSTOM WOOD
- UNDER SCALLOP
- CUSTOM METAL
- CEDAR POST

GATE INFORMATION

#1:	4'	<input type="checkbox"/> SS	<input type="checkbox"/> DD
#2:	4'	<input type="checkbox"/> SS	<input type="checkbox"/> DD
#3:		<input type="checkbox"/> SS	<input type="checkbox"/> DD
#4:		<input type="checkbox"/> SS	<input type="checkbox"/> DD

FENCE #1 _____

FENCE #2 _____

PERMIT NA

OPTIONAL ITEMS BELOW ARE NOT INCLUDED IN FENCE PRICE

- TEAR OUT
- HAND DIGS
- SURVEY
- SPRINKLER INS. Optional
- DIRT REMOVAL Optional

OPTIONAL ITEMS SUB TOTAL _____

TOTAL _____

QUOTE IS GOOD FOR 15 DAYS

Description:
 Provide & install 6' tall white vinyl fence per drawing above. Price includes tax, material and labor.

Includes Removal of clothes line posts \$6755⁰⁰

AFC REPRESENTATIVE:	DATE	OFFICE USE ONLY	DATE
Chad Hancock	5/2/2019		TYPE
CUSTOMER SIGNATURE:	DATE	AMOUNT	

421 Sheridan (Janulewicz) - Okay to attach their fence to des page
 1223 Elm (Sonney) - *[Signature]*



A Special Note

8/6/19

OK to attach to our fence.
will use a separation spacer
in between attachment to
indicate division of property that
belongs to owners of 1223 Elm Street.

GORDON A. SENNEY

Audrey Senney
08/06/19

Zoning Classification R-2

Value \$ 1500

PERMIT NUMBER 2019-46

FEE \$25.00 CASH CHECK# 1611 CC

APPLICATION FOR A FENCE PERMIT

St. Paul, Nebraska: DIRECTIONS: Fill in the following information as accurately and completely as possible. This application is not acceptable unless all required information is furnished.

Property Owner Brian Sack and Cathryn Sack Contractor American Fence Company

Address 1104 7th Street Address 1605 N Shady Bend Rd

City, State, Zip St Paul NE 68873 Phone Number 308 395 0793

Phone Number 402 309 0935 Cell Phone

Complete Legal Description of the Property LOT 7 BLOCK 4 OT ST PAUL

Address of Fence Site 1104 7th Street Size & Kind white vinyl 6' privacy

Replacement or New Fence: replacement along 2 rear sides Front side (south)

Approximately when will the construction: Start 8/17/19 Finish 8/25/19

To Whom Should the Improvements be assessed? Brian Sack and Cathryn Sack

Contact Utility Superintendent at (308) 754-4483 regarding Inspection Matt Helzer Date of visit 8-7-19
(Matt Helzer's signature)

Recommendations needed before approval:

MUST CALL DIGGERS HOTLINE @ 811 BEFORE DIGGING – CONSTRUCTION ON UTILITY EASEMENTS IS NOT PERMITTED. The above information is, to the best of my knowledge, true and accurate. It is understood and agreed that any error, misstatement or misrepresentation of fact, either with or without intention on my part, such as might, if known, cause a refusal of this application, or any alteration or change in plans made without the approval of the Zoning Administrator subsequent to the issuance of the Permit, shall constitute sufficient grounds for the revocation of such permit. This permit is valid for one (1) year from approval date.

The signature also indicates permission granted to the Zoning Administrator to inspect the site in which this permit is granted at any time until completed.

Signature of Applicant [Signature] Date 8-6-19

N 6"
Drawing:

W 85'

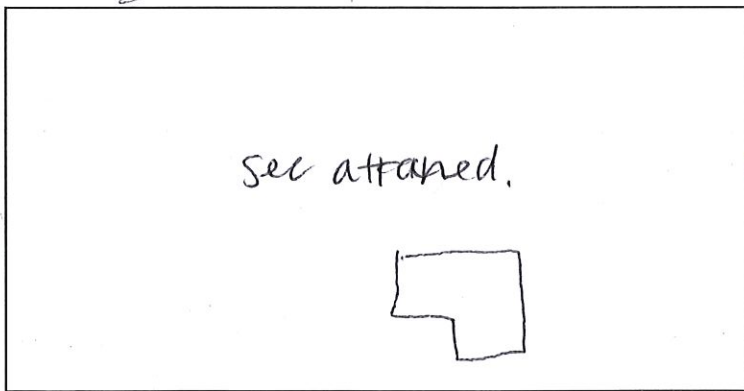

E 1'

For Office Use Only:
Permit is Approved Denied S 2' Date
Zoning Administrator

Reasons for Denial:

2019-46

AMERICAN FENCE COMPANY

Omaha Lincoln Des Moines
1605 North Shady Bend Road
Grand Island, NE 68801

Sioux Falls Grand Island
Office: (308) 395-0793
Email: c.hancock@americafence.com

Kansas City Rochester
SALESMAN Chad Hancock
Phone: 308-379-0666

DATE 7/3/2019 PHONE: 402-309-9935 CELL: _____
CUSTOMER Cathy Sack WORK: _____
PROJECT LOCATION: 1104 7th Street
CITY St Paul STATE NE ZIP 68873
BILLING ADDRESS: _____ AFC JOB # _____
CITY _____ STATE NE ZIP _____

SPECIFICATION FOR FENCE - RAILINGS
STYLE DRAWING _____
K 373
OVERALL LENGTH 156'
OVERALL HEIGHT 6'

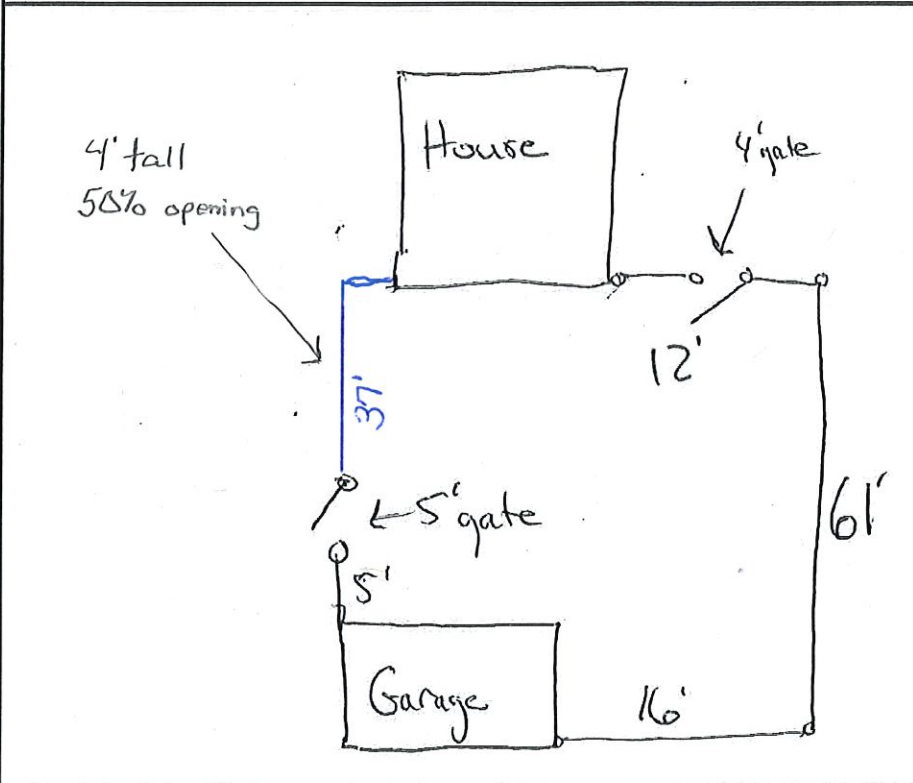

EMAIL _____

SPECIAL NOTES:

Materials, Labor, & Tax all included. The posts are set using concrete.

- CORNER LOT
- FRENCH GOTHIC
- REPAIR
- OVER SCALLOP
- CUSTOM WOOD
- UNDER SCALLOP
- CUSTOM METAL
- CEDAR POST

GATE INFORMATION

- #1: 4' SS DD
- #2: 5' SS DD
- #3: _____ SS DD
- #4: _____ SS DD

FENCE #1 _____

FENCE #2 _____

PERMIT By Owner

OPTIONAL ITEMS BELOW ARE NOT INCLUDED IN FENCE PRICE

- TEAR OUT _____
- HAND DIGS _____
- SURVEY _____
- SPRINKLER INS. _____ Optional
- DIRT REMOVAL _____ Optional

OPTIONAL ITEMS SUB TOTAL _____

TOTAL _____

QUOTE IS GOOD FOR 15 DAYS

Description:

Provide & install 6' solid vinyl fence per drawing. White in color. Prices include tax, material & labor.

AFC REPRESENTATIVE: Chad Hancock DATE 5/2/2019

CUSTOMER SIGNATURE: _____ DATE _____

OFFICE USE ONLY

DATE _____

TYPE _____

AMOUNT _____

Zoning Classification R-2

Value \$ 400.00

PERMIT NUMBER 2019-47
FEE \$25.00 CASH CHECK# 2330 CC

APPLICATION FOR A FENCE PERMIT

St. Paul, Nebraska: DIRECTIONS: Fill in the following information as accurately and completely as possible. This application is not acceptable unless all required information is furnished.

Property Owner Bill + Karen Northrup Contractor Self

Address 922 Indian Street Address _____

City, State, Zip St. Paul, NE 68873 Phone Number _____

Phone Number 308-571-0041 Cell Phone _____

Complete Legal Description of the Property Lot 7 + W 38' of Lot 8 Block 6 Bartletts Add St. Paul

Address of Fence Site 922 Indian Street Size & Kind 6' wood fence

Replacement or New Fence: Add to existing fence Approx. 24'

Approximately when will the construction: Start Aug 2019 Finish Sept 2019

To Whom Should the Improvements be assessed? _____

Contact Utility Superintendent at (308) 754-4483 regarding Inspection Matt Helzer Date of visit 8-8-19
(Matt Helzer's signature)

Recommendations needed before approval: _____

MUST CALL DIGGERS HOTLINE @ 811 BEFORE DIGGING – CONSTRUCTION ON UTILITY EASEMENTS IS NOT PERMITTED. The above information is, to the best of my knowledge, true and accurate. It is understood and agreed that any error, misstatement or misrepresentation of fact, either with or without intention on my part, such as might, if known, cause a refusal of this application, or any alteration or change in plans made without the approval of the Zoning Administrator subsequent to the issuance of the Permit, shall constitute sufficient grounds for the revocation of such permit. This permit is valid for one (1) year from approval date. The signature also indicates permission granted to the Zoning Administrator to inspect the site in which this permit is granted at any time until completed.

Signature of Applicant Bill Northrup Date _____

N 75'
Drawing:

W 63'

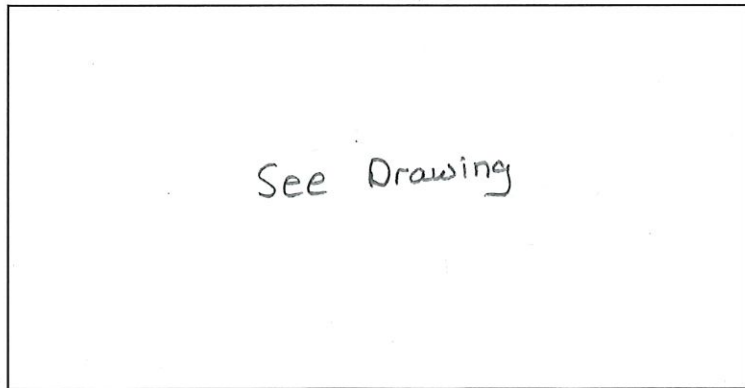

E 6''

For Office Use Only: Permit is Approved Denied S 57' Date _____
Zoning Administrator

Reasons for Denial: _____

North ↑

Current Move: L2/U8

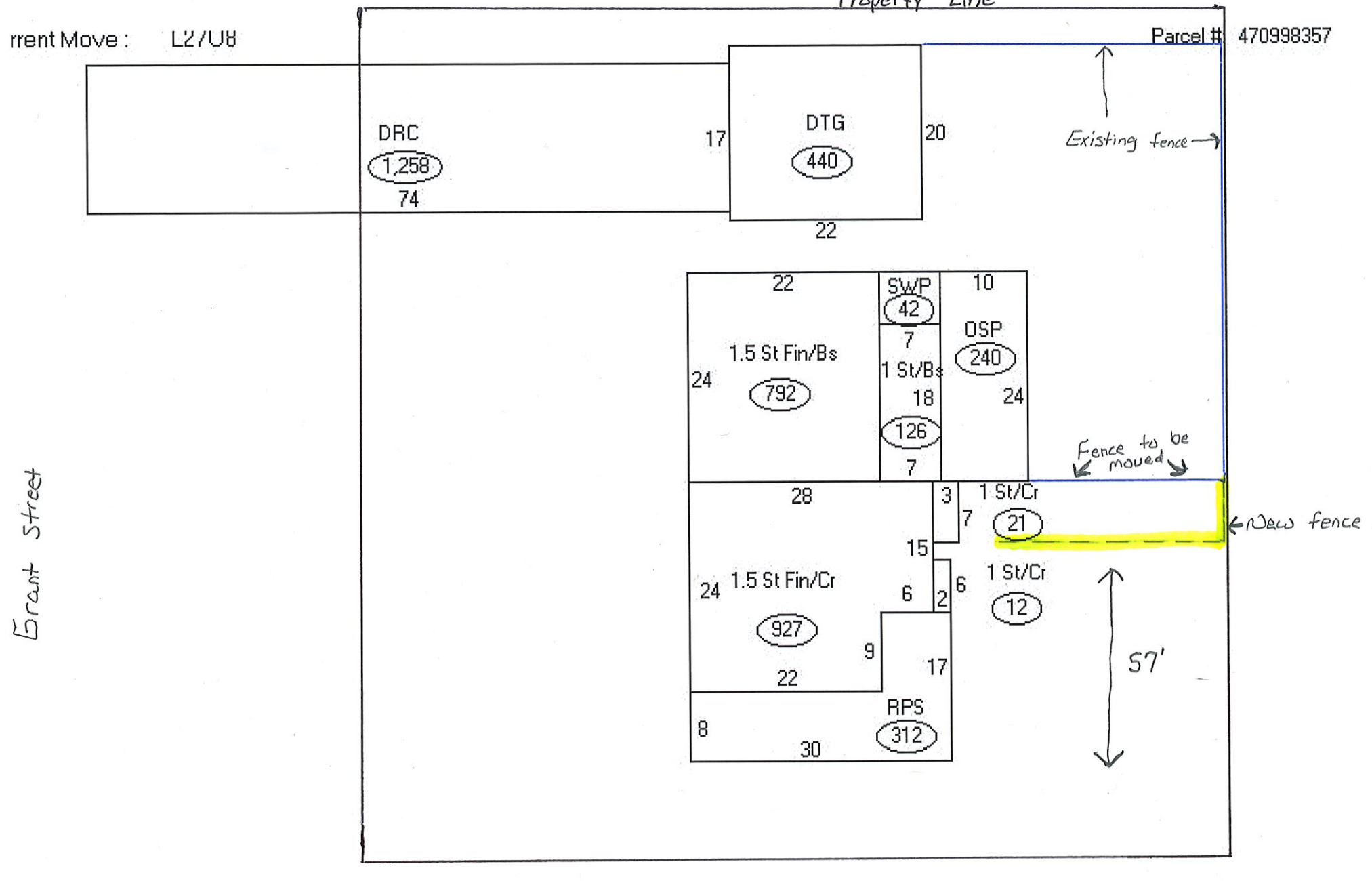

Zoning Classification Light Industrial Value \$ 58,000
Please call 811 Diggers Hotline before designing

PERMIT NUMBER 2019-48
FEE \$ 100.00 CASH CHECK# 8/9/19

APPLICATION FOR A COMMERCIAL ZONING PERMIT

St. Paul, Nebraska: DIRECTIONS: Fill in the following information as accurately and completely as possible. This application is not acceptable unless all requirement information is furnished.

Property Owner Jevander Body shop Brian Jevander Contractor Jevanders construction
Address NEW? Address 1509 Indian St St Paul NE
City, State, Zip St Paul NE ^{Travel Island NE} 68873 68808 Phone Number
Phone Number 308 390 6494 Cell Phone 308 750 3335

Complete Legal Description of the Property

Address of Construction Site 323 Elm St St Paul NE 68873
(If none, one must be registered with City of St. Paul or the 911 center.) In the Flood Plain NO?

Proposed Structure & Use auto break down + prep Dimension of Structure 30x56

Distance from Front property line ^{North} 109' Plans Submitted to Fire Marshall Office Yes

Rear ^{South} Property Line 11ft Side Property Line ^{West} 26ft Second Side Line ^{East} 76' Between other buildings (Min 10') 11ft

Is there a utility easement on either the back or side property? If so attach a copy of neighbor approval.

Approximately when will construction Start Aug 28th Sep 1st Finish By Oct 30th

To Whom Should the Improvements be assessed? Jevanders Body Shop

Contact Utility Superintendent at (308) 754-4483 regarding Set-Back Inspection. Matt Helzer Date of visit 8-9-19
(Matt Helzer's signature)

Recommendations needed before approval:

(One Mile radius outside city limits) If the structure is a residence on less than 10 acres indicate the date this property was platted as a separate parcel and the Name of the Lot Split or Subdivision,

For Office Use Only:

Is the proposed use permitted within this zoning district? ✓ YES NO
Does the proposed use meet all the required setback distances? ✓ YES NO
Is a conditional use required for the proposed use? YES ✓ NO
Has a Conditional Use Permit been issued for this proposed use? YES ✓ NO
If yes, when does it expire?

Site Plan Sketch:

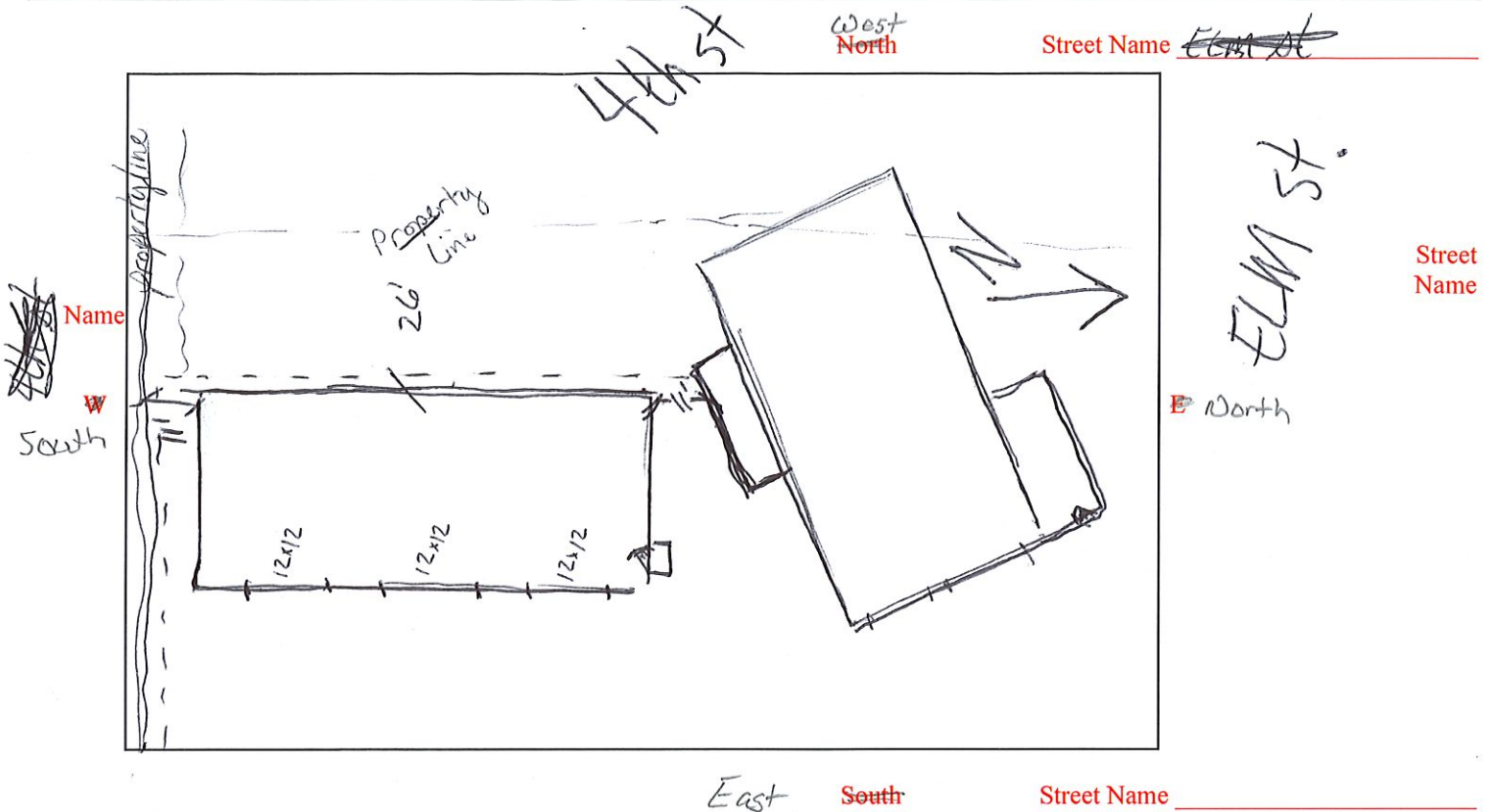

Indicate, by drawing, the shape and dimensions of the land, shape and dimensions of all existing and proposed building and structures and the distances from the proposed building and structures to all lot lines (from road frontages, side and rear lot lines). Show the location of roads fronting the property. **MUST CALL DIGGERS HOTLINE @ 811 BEFORE DIGGING – CONSTRUCTION ON UTILITY EASEMENTS IS NOT PERMITTED. NEW CONSTRUCTION MUST CALL Electrical Inspector, Kim Farnstrom 308-728-7612**

The above information is, to the best of my knowledge, true and accurate. It is understood and agreed that any error, misstatement or misrepresentation of fact, either with or without intention on my part, such as might, if known, cause a refusal of this application, or any alteration or change in plans made without the approval of the Zoning Administrator subsequent to the issuance of the Permit, shall constitute sufficient grounds for the revocation of such permit. This permit is valid for one (1) year from approval date and work must be started within the first 6 months.

The signature also indicates permission granted to the Zoning Administrator to inspect the construction site in which this permit is granted at any time until construction is completed and a Certificate of Occupancy is issued.

Signature of Applicant *Scott K. Lewander* Date *August 9/2019*

For Office Use Only:

Permit is Approved _____ Denied _____ Date _____
 Zoning Administrator

Reasons for Denial:

Zoning Classification R-3 Value \$ 5,000
Please call 811 before completing form

PERMIT NUMBER 2019-49
FEE \$ 25.00 CASH CHECK# 1373

APPLICATION FOR A RESIDENTIAL ZONING PERMIT

St. Paul, Nebraska: DIRECTIONS: Fill in the following information as accurately and completely as possible. This application is not acceptable unless all requirement information is furnished.

Property Owner Glenn James Contractor John Hulinsky

Address 424 N. Sherman Ave. Address _____

City, State, Zip Grand Island, NE 68803 Phone Number _____

Phone Number (308) 381-0540 Cell Phone 308 745-5656

Complete Legal Description of the Property Lots 17 and 18 Block 30 OT St. Paul

Address of Construction Site 422 6th Street, St. Paul
(If none, one must be registered with City of St. Paul) In the Flood plain NO ?

Proposed Structure Eazebo + deck extension Dimension of Structure 12' Octagon

Distance from Front property line ^{North} 30' 6"

Rear Property Line ^{South} 45' 6" Side Property Line ^{East} 42' Second Side Line ^{West} 78' Between other buildings (Min 10') 24'

Is there a utility easement on either the back or side property? NO If so attach a copy of neighbor approval.

Approximately when will construction Start Aug 2019 Finish Aug 2020

To Whom Should the Improvements be assessed? _____

Contact Utility Superintendent at (308) 754-4483 regarding Set-Back Inspection. Matt Helzer Date of visit 8-9-19
(Matt Helzer's signature)

Recommendations needed before approval: _____

(One Mile radius outside city limits) If the structure is a residence on less than 10 acres indicate the date this property was platted as a separate parcel _____ and the Name of the Lot Split or Subdivision, _____

For Office Use Only:
Is the proposed use permitted within this zoning district? _____ YES _____ NO
Does the proposed use meet all the required setback distances? _____ YES _____ NO
Is a conditional use required for the proposed use? _____ YES _____ NO
Has a Conditional Use Permit been issued for this proposed use? _____ YES _____ NO
If yes, when does it expire? _____

Site Plan Sketch:

North Street Name Elm



South Street Name Davis

Indicate, by drawing, the shape and dimensions of the land, shape and dimensions of all existing and proposed building and structures and the distances from the proposed building and structures to all lot lines (from road frontages, side and rear lot lines). Show the location of roads fronting the property. **MUST CALL DIGGERS HOTLINE @ 811 BEFORE DIGGING – CONSTRUCTION ON UTILITY EASEMENTS IS NOT PERMITTED. NEW HOMES MUST CALL ELECTRICAL INSPECTOR, Kim Farnstrom 308-728-7612**

The above information is, to the best of my knowledge, true and accurate. It is understood and agreed that any error, misstatement or misrepresentation of fact, either with or without intention on my part, such as might, if known, cause a refusal of this application, or any alteration or change in plans made without the approval of the Zoning Administrator subsequent to the issuance of the Permit, shall constitute sufficient grounds for the revocation of such permit. This permit is valid for one (1) year from approval date and work must be started within the first 6 months.

The signature also indicates permission granted to the Zoning Administrator to inspect the construction site in which this permit is granted at any time until construction is completed and a Certificate of Occupancy is issued.

Signature of Applicant *Allen Jones* Date 7/25/2019

For Office Use Only:

Permit is Approved _____ Denied _____ Date _____
Zoning Administrator

Reasons for Denial:



1-800-700-1777

Design Your Own

Gazebos

Pergolas

Pavilions

Commercial

« Back to Main Menu



Your Gazebo is Complete!

Call us today at **1-800-700-1777** to speak with a gazebo designer.

Gazebo Basics

Type: Gazebo
Shape: Octagon
Material: Vinyl
Size: 12 ft

Customized Options

Roof: Majestic
Cornice: Straight
Posts: Turned
Braces: Standard

Colors

Color: White Vinyl
Roof: Earthtone Cedar
Floorboard: No Deck

Enclosures

Screens: Screen Package

Accessories

Electrical Package: 1
Additional Outlets: 0
Ceiling Fan: None
Wall Mounted Heater: 0
Weathervane: No
Benches: 0
Patío Set: None



Elm Street

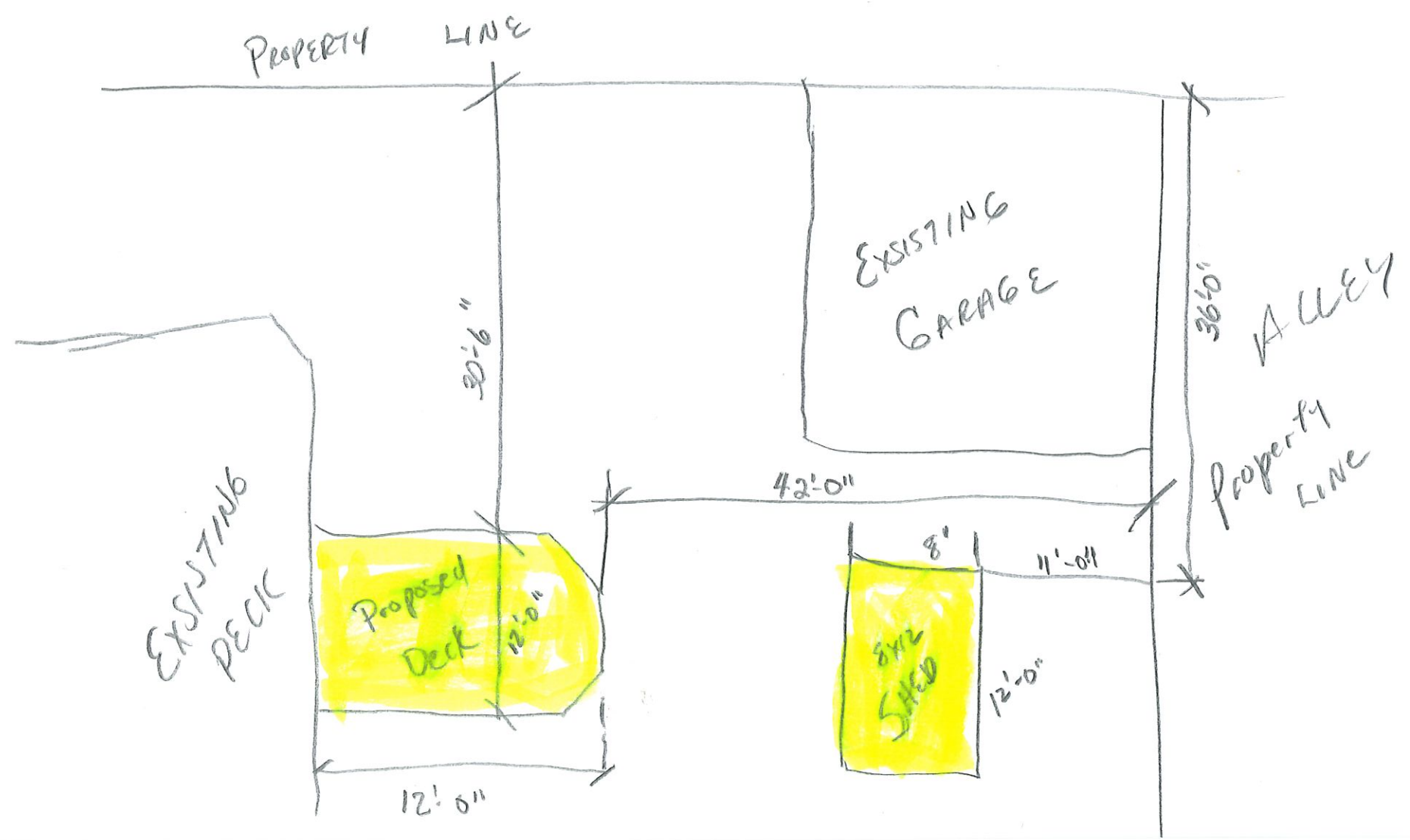

Zoning Classification R-1 Value \$ 1500.⁰⁰
Please call 811 before completing form

PERMIT NUMBER 2019-50
FEE \$ 25.⁰⁰ CASH CHECK#

APPLICATION FOR A RESIDENTIAL ZONING PERMIT

St. Paul, Nebraska: DIRECTIONS: Fill in the following information as accurately and completely as possible. This application is not acceptable unless all requirement information is furnished.

Property Owner Douglas + Pamela Ackles Contractor Eordy Christensen

Address 1705 Custer Street Address 122 Sheridan Street

City, State, Zip St Paul, NE 68873 Phone Number

Phone Number Cell Phone 308-750-1130

Complete Legal Description of the Property Lots 52 + 53 Kelly's First Add St. Paul

Address of Construction Site 1705 Custer Street
(If none, one must be registered with City of St. Paul) In the Flood plain NO?

Proposed Structure Wood Handicap Ramp Dimension of Structure 4' x 38'

Distance from Front property line 51'
^{North}

Rear Property Line 60' ^{South} Side Property Line 21' ^{East} Second Side Line 87' ^{West} Between other buildings (Min 10')

Is there a utility easement on either the back or side property? YES If so attach a copy of neighbor approval.

Approximately when will construction Start Aug 2019 Finish Sept. 2019

To Whom Should the Improvements be assessed? Doug + Pam Ackles

Contact Utility Superintendent at (308) 754-4483 regarding Set-Back Inspection. Matt Helzer Date of visit 8-9-19
(Matt Helzer's signature)

Recommendations needed before approval: Article 9.1.03 - 2A

(One Mile radius outside city limits) If the structure is a residence on less than 10 acres indicate the date this property was platted as a separate parcel and the Name of the Lot Split or Subdivision,

For Office Use Only:

Is the proposed use permitted within this zoning district? YES NO

Does the proposed use meet all the required setback distances? YES NO

Is a conditional use required for the proposed use? YES NO

Has a Conditional Use Permit been issued for this proposed use? YES NO
If yes, when does it expire?

PERMIT NUMBER 2019-50

Site Plan Sketch:

North Street Name _____

Street Name _____

W _____

Street Name _____

E _____

South Street Name _____

See attached map

Indicate, by drawing, the shape and dimensions of the land, shape and dimensions of all existing and proposed building and structures and the distances from the proposed building and structures to all lot lines (from road frontages, side and rear lot lines). Show the location of roads fronting the property. **MUST CALL DIGGERS HOTLINE @ 811 BEFORE DIGGING – CONSTRUCTION ON UTILITY EASEMENTS IS NOT PERMITTED. NEW HOMES MUST CALL ELECTRICAL INSPECTOR, Kim Farnstrom 308-728-7612**

The above information is, to the best of my knowledge, true and accurate. It is understood and agreed that any error, misstatement or misrepresentation of fact, either with or without intention on my part, such as might, if known, cause a refusal of this application, or any alteration or change in plans made without the approval of the Zoning Administrator subsequent to the issuance of the Permit, shall constitute sufficient grounds for the revocation of such permit. This permit is valid for one (1) year from approval date and work must be started within the first 6 months.

The signature also indicates permission granted to the Zoning Administrator to inspect the construction site in which this permit is granted at any time until construction is completed and a Certificate of Occupancy is issued.

Signature of Applicant *Sandy Christian* Date 8/9/19

For Office Use Only:

Permit is Approved _____ Denied _____ Date _____
Zoning Administrator

Reasons for Denial:

2019-50

Kelly Street

Property Line

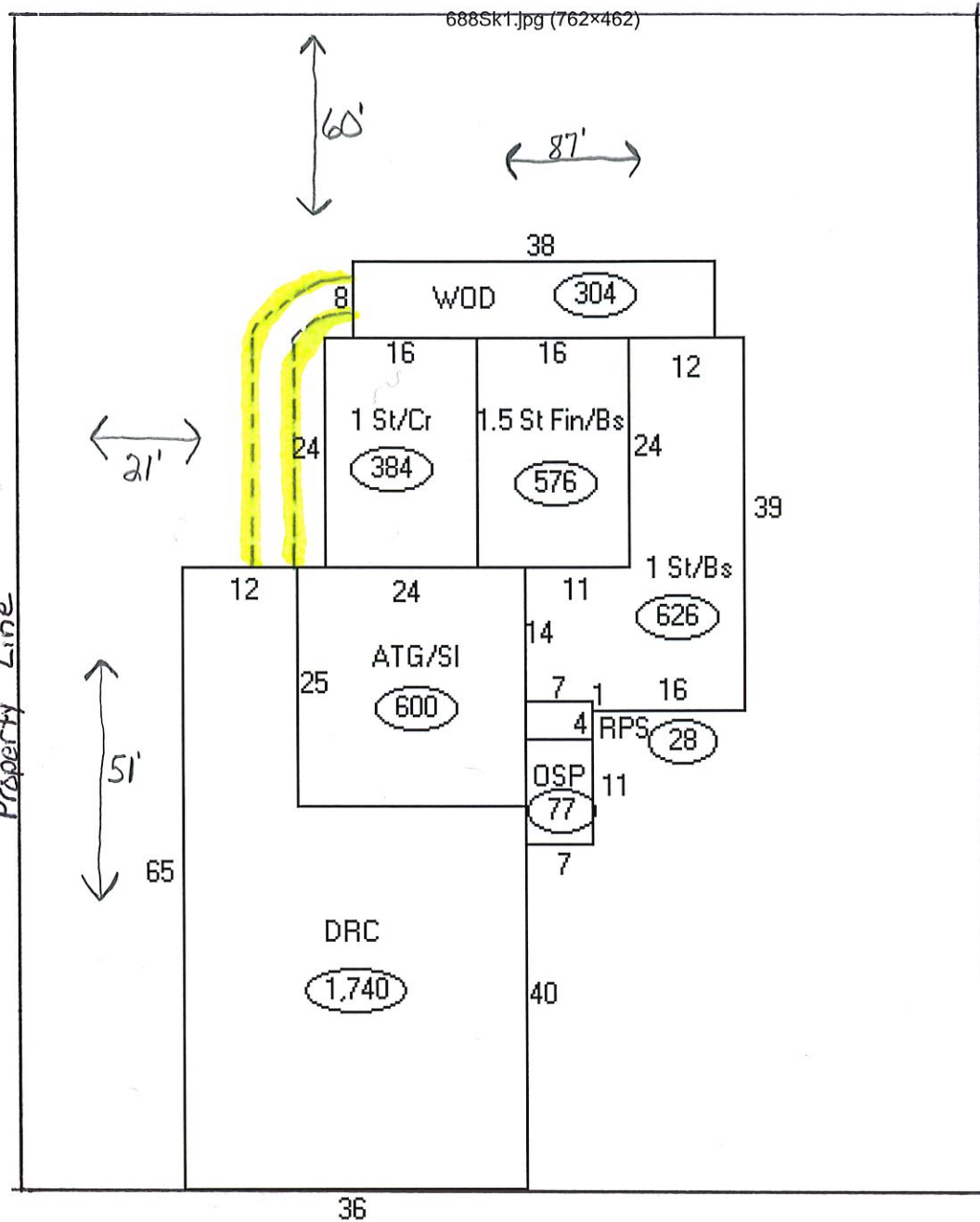

Custer Street

Zoning Classification R2

PERMIT NUMBER 2019-51
FEE \$10.00 CASH _____ CHECK# 7203

APPLICATION FOR A DEMOLITION PERMIT

St. Paul, Nebraska: DIRECTIONS: Fill in the following information as accurately and completely as possible. This application is not acceptable unless all required information is furnished.

Property Owner Margaret Thompson Contractor Jim Thompson

Address 1604 Paul st Address 726 12th Ave ST Paul

City, State, Zip ST Paul Ne 68873 Phone Number _____

Phone Number 308 754-4584 Cell Phone 308 571-0454

Complete Legal Description of the Property (SP TWP) tract in SW 1/4 SW 1/4 33-15-10

Address of Demolition Site 1604 Paul st ST Paul (8 acres)

Structure to be demolished barn

Approximately when will demolition Start 9-1-19 Finish 12-15-19

Asbestos Inspection Conducted? Yes _____ No X **Attach inspection report.**

To Whom Should the Improvements be assessed? Margaret Thompson

Contact Utility Superintendent at (308) 754-4483 regarding Inspection. Date of visit Matt Helzer 8-9-19
(Matt Helzer's signature)

Recommendations needed before approval: _____

MUST CALL DIGGERS HOTLINE @ 811 BEFORE DIGGING – CONSTRUCTION ON UTILITY EASEMENTS IS NOT PERMITTED. The above information is, to the best of my knowledge, true and accurate. It is understood and agreed that any error, misstatement or misrepresentation of fact, either with or without intention on my part, such as might, if known, cause a refusal of this application, or any alteration or change in plans made without the approval of the Zoning Administrator subsequent to the issuance of the Permit, shall constitute sufficient grounds for the revocation of such permit. This permit is valid for one (1) year from approval date.

The signature also indicates permission granted to the Zoning Administrator to inspect the demolition site in which this permit is granted at any time until completed.

Signature of Applicant Margaret Thompson Date 8-9-19

Taxes must be paid in full prior to demolishing/removing any structure. Treasurer's certificate of approval to move or demolish the building MUST be attached.

For Office Use Only:

Permit is Approved _____ Denied _____ Date _____
Zoning Administrator

Reasons for Denial: _____



2019-51

TAX RECEIPT

JACKIE SYNOWSKI HOWARD COUNTY TREASURER

Parcel # 470307230	Roll Year 2018	Receipt No. 2018-0002100
Legal (SP TWP) TRACT IN SW1/4 SW1/4		Date of Payment: 04/18/2019
33-15-10 (8 ACRES)		Type of Tax: REAL

1604 PAUL ST			
Tax Due 12/31/2018	TAX DISTRICT 2	Original Tax	498.84
Delinquent	TAX RATE 1.252572	Tax Before Credit	923.30
1st Half 05/01/2019	VALUE 79,179	Homstead Credit	424.46
2nd Half 09/04/2019		Late Filing Fee:	0.00

MTHOMPSON CHECK
 PAID BY: MARGARET THOMPSON

The tax loss is reimbursed by the state as a homestead exemption.
 Receipt voided until final payment of any check or draft tendered.

THOMPSON/MARGARET	Payment	1st HALF
	Installment	249.42
	Interest	0.00
	Advertising	0.00
	Penalty	0.00

1604 PAUL ST
 ST PAUL NE 68873-3613

TOTAL COLLECTED 249.42

COMMENTS

RECEIPT

TAX RECEIPT

JACKIE SYNOWSKI HOWARD COUNTY TREASURER

Parcel # 470307230	Roll Year 2018	Receipt No. 2018-0005844
Legal (SP TWP) TRACT IN SW1/4 SW1/4		Date of Payment: 08/09/2019
33-15-10 (8 ACRES)		Type of Tax: REAL

1604 PAUL ST			
Tax Due 12/31/2018	TAX DISTRICT 2	Original Tax	498.84
Delinquent	TAX RATE 1.252572	Tax Before Credit	923.30
1st Half 05/01/2019	VALUE 79,179	Homstead Credit	424.46
2nd Half 09/04/2019		Late Filing Fee:	0.00

MTHOMPSON CHECK
 PAID BY: MARGARET THOMPSON

The tax loss is reimbursed by the state as a homestead exemption.
 Receipt voided until final payment of any check or draft tendered.

THOMPSON/MARGARET	Payment	2nd HALF
	Installment	249.42
	Interest	0.00
	Advertising	0.00
	Penalty	0.00

1604 PAUL ST
 ST PAUL NE 68873-3613

TOTAL COLLECTED 249.42

COMMENTS

RECEIPT

CITY OF SAINT PAUL
PLANNING & ZONING COMMISSION
APPLICATION FOR ADMINISTRATIVE SUBDIVISION

Application Fee: \$100.00
Paid: 7/1/19 Check _____ Cash _____
cc-✓

To Be Completed by Applicant

Date Submitted: 7/1/19
Name of Subdivision: Rice's Subdivision
Applicant's Name: James & Diane Rice 308-383-1619
Address: 904 12th Ave St. Paul NE 68873
Legal Description: See attached

Current Number of Lots: 1 Proposed Number of Lots: 2
Present Zoning: _____ Requested Zoning: _____

Name(s) of Current Owner(s): Lots 1 + 2 James & Diane Rice
Name of Proposed Owner(s): Lot 1 " "
Lot 2 Justin Alan Miller
Proposed Use of Property: Same use

Within City Limits	Yes _____	No <u>X</u>	
Adjacent to City Limits	Yes _____	No <u>X</u>	
Within 1 Mile Zoning Jurisdiction	Yes <u>X</u>	No _____	
Annexation Requested	Yes _____	No <u>X</u>	
Drainage Plan submitted	Yes _____	No _____	N/A <u>X</u> (waived by Planning Admin)

James Rice
Applicant's Signature

Note: At the time of application, the Applicant must submit the appropriate application fee, and documents as required in the St. Paul Subdivision Regulations.

Following review, the Planning and Zoning Administrator shall refer the application for approval in the following order: City Engineer, Public Works Superintendent, Chairperson of the Planning Commission, and Mayor. If any party rejects the replat of subdivision, approval of such subdivision is denied. Approval shall be denoted by a signed Certificate of Approval which must be filed with the plat with the Register of Deeds of Howard County, Nebraska.

In the case of a denial, the proposed replatted subdivision may proceed through the appropriate review and action for a typical subdivision approval process.

Following approval of the replatted subdivision, the Subdivider must file the plat and Certificate of Approval with the Register of Deeds of Howard County, Nebraska. If the Certificate of Approval and the approved replat are not filed with the Register of Deeds of Howard County within 90 days of approval, such approval shall be null and void.

	<u>APPROVE / DENY</u>		<u>SIGNATURE</u>
City Engineer	Yes <u>X</u>	No _____	<u>Jim R. Labbs</u>
Waive submission of Preliminary & Final Plat	_____		_____
Public Works	Yes <u>X</u>	No _____	<u>Matthew Thayer</u>
Superintendent	Yes <u>X</u>	No _____	<u>Matthew Thayer</u>
Planning Commission	Yes _____	No _____	_____
Mayor	Yes _____	No _____	_____

James A. and Dianne S. Rice
Administrative Subdivision

A Tract in part of NE ¼ Section 10 and Part
of NW ¼ Section 11, Township 14 North,
Range 10, West of the 6th P.M., Howard
County, Nebraska

(26.02 Acres)

Subdivided Into:

Lots One (1) and Lots (2), Rice Subdivision

N-LINE



LAND SURVEYING

P.O. BOX 173
Central City, NE 68926
Phone: 308-946-3581

RICE'S SUBDIVISION

AN ADMINISTRATIVE REPLAT LOCATED IN THE PART OF THE NORTHEAST QUARTER (NE1/4) OF SECTION 10 AND THE NORTHWEST QUARTER (NW1/4) OF SECTION 11, TOWNSHIP 14 NORTH, RANGE 10 WEST OF THE 6th P.M., HOWARD COUNTY, NEBRASKA

NORTH MEANDER CORNER OF THE LEFT LOUP RIVER BANK (C/O S 8) OF SECTION 10 (T 14 N, R 10 W)
Found Brass Cap
W 15.35' P.K. Nail in Fence Post
S 2.62' P.K. Nail in 4" Tree
NE 0.25' BLK Cap

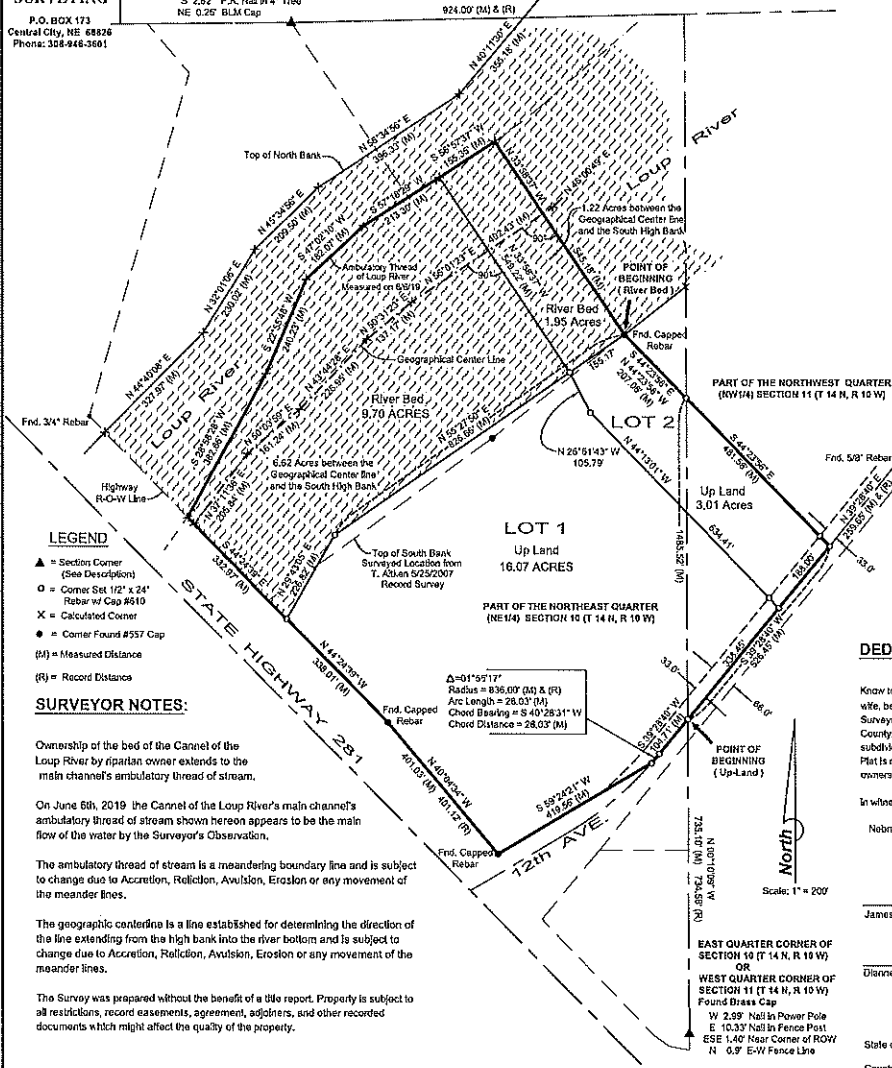

- LEGEND**
- ▲ = Section Corner (See Description)
 - = Corner Set 12" x 24" Rebar w/ Cap #610
 - ✕ = Calculated Corner
 - = Corner Found #557 Cap
 - (M) = Measured Distance
 - (R) = Record Distance

SURVEYOR NOTES:

Ownership of the bed of the Channel of the Loup River by riparian owner extends to the main channel's ambulatory thread of stream.

On June 6th, 2019 the Channel of the Loup River's main channel's ambulatory thread of stream shown hereon appears to be the main flow of the water by the Surveyor's Observation.

The ambulatory thread of stream is a meandering boundary line and is subject to change due to Accretion, Reliction, Avulsion, Erosion or any movement of the meander lines.

The geographic centerline is a line established for determining the direction of the line extending from the high bank in the river bottom and is subject to change due to Accretion, Reliction, Avulsion, Erosion or any movement of the meander lines.

The Survey was prepared without the benefit of a title report. Property is subject to all restrictions, record easements, agreement, adjoiners, and other recorded documents which might affect the quality of the property.

SURVEYOR'S CERTIFICATE

I hereby certify that this Subdivision Survey was prepared by me and the related survey work was performed by me or under my direct personal supervision and that I am a duly Registered Land Surveyor under the laws of the State of Nebraska.

Janis L. Blodgett License Number 610
Pages Covered by this Seal: 1 of 1



STATE OF NEBRASKA
HOWARD COUNTY
FILED FOR RECORD

MO _____ DAY _____ 20____
AT _____ O'CLOCK _____ M. RECORDED
IN SURVEY BOOK _____ OF PAGE _____
BY _____ COUNTY CLERK

RICE'S SUBDIVISION DESCRIPTION:

The Upland Tract of Land located in part of the Northeast Quarter (NE1/4) of Section 10 and Part of the Northwest Quarter (NW1/4) in Section 11, Township 14 North, Range 10 West of the 6th P.M., Howard County Nebraska, more particularly describes as follows:

Commencing at the East Quarter Corner of said Section 10; thence on an assigned bearing of North 00°10'09" West on the easterly line of the said Northeast Quarter (NE1/4) a distance of 735.10 feet to the Center Line of 12th Avenue and also being the Point of Beginning; thence South 39°28'40" West on the said center line a distance of 104.71 feet; thence 28.03 feet on a 836.00 foot radius curving to the right with a chord bearing of South 40°28'31" West and a chord distance of 28.03 feet to the easterly Right of Way line of State Highway 14; thence South 59°24'21" West on said easterly right-of-way line a distance of 418.50 feet; thence North 40°04'34" West on said easterly right-of-way line a distance of 401.63 feet; thence North 44°24'30" West on said right-of-way line a distance of 338.01 feet to the current South High Bank of the Loup River; thence North 29°43'05" East on said high bank a distance of 228.82 feet; thence North 53°27'50" East on said high bank a distance of 826.66 feet to the easterly line of a record tract of land described and recorded in Book 07, page 3607 in the Howard County Clerk's Office; thence South 44°23'50" East on said easterly line a distance of 207.95 feet to the westerly line of the Northwest Quarter (NW1/4) of said Section 11; thence continuing South 44°23'56" East on said easterly line a distance of 481.56 feet to the Center Line of 12th Avenue; thence South 39°28'40" West on said center line a distance of 826.45 feet to the point of beginning.

The River Bed Tract of Land located in part of the Northeast Quarter (NE1/4) of Section 10 and Part of the Northwest Quarter (NW1/4) in Section 11, Township 14 North, Range 10 West of the 6th P.M., Howard County Nebraska, more particularly describes as follows:

Commencing at the East Quarter Corner of said Section 10; thence on an assigned bearing of North 00°10'09" West on the easterly line of said Northeast Quarter (NE1/4) a distance of 1485.52 feet to the easterly line of a record tract of land described and recorded in Book 07, page 3507 in the Howard County Clerk's Office; thence North 44°23'56" West on said easterly record tract a distance of 207.95 feet to the current South High Bank of the Loup River and also being the Point of Beginning; thence North 33°58'37" West and perpendicular to the Geographical Center Line of the Loup River a distance of 645.18 feet to the ambulatory thread of the Loup River; thence on said ambulatory thread for the next Five (5) courses; South 56°57'37" West on course One (1) a distance of 155.35 feet; thence South 57°16'29" West on course Two (2) a distance of 213.30 feet; thence South 47°32'10" West on course Three (3) a distance of 182.07 feet; thence South 22°55'48" West on course Four (4) a distance of 240.23 feet; thence South 28°58'20" West on course Five (5) a distance of 302.68 feet to the easterly Right of Way line of State Highway 14; thence South 44°24'30" East on said easterly right-of-way line a distance of 332.87 feet to the current South High Bank of the Loup River; thence North 29°43'05" East on said high bank a distance of 226.85 feet; thence North 53°27'50" East on said high bank a distance of 826.66 feet to the point of beginning.

Subject to all easements and restrictions of record.

RECORD DESCRIPTION (Book 07, Page 3607):

A tract of land located in part of the Northeast Quarter (NE1/4) in Section Ten (10), and Part of the Northwest Quarter (NW1/4) in Section Eleven (11), Township Fourteen (14) North, Range Ten (10) West of the 6th P.M., Howard County, Nebraska, and more particularly described as follows: Commencing at the East 1/4 corner of Sec. 10-T14N-R10W; thence on an assumed bearing of N 00° 50'34" E upon and along the East line of the NE1/4 a distance of 134.56 feet to the Point of Beginning; thence S 40° 31' 06" W a distance of 103.99 feet to a point of curvature; thence around a curve in a clock wise direction having a Delta Angle of 01° 55' 18", a radius of 835.00 feet, and a chord bearing of S 41° 28' 45" W with a chord distance of 28.04 feet to a point on the North Right-of-Way (ROW) line of US Highway 281; thence S 60° 26' 44" W upon and along said US Hwy 281 North ROW line a distance of 145.76 feet to the northerly ROW line of County Road; thence continuing S 60° 26' 44" W upon and along said US Hwy 281 North ROW line a distance of 232.63 feet; thence continuing S 60° 26' 44" W upon and along said ROW line a distance of 41.18 feet to a point on the Easterly ROW line of US Highway 281; thence N 29° 00' 23" W upon and along said Easterly ROW line a distance of 401.12 feet; thence N 43° 21' 22" W upon and along said Easterly ROW line a distance of 398.72 feet to a point; thence N 55° 08' 12" E a distance of 647.91 feet; thence N 65° 08' 12" E a distance of 647.91 feet; thence N 55° 08' 12" E a distance of 260.59 feet; thence N 52° 46' 10" E a distance of 133.71 feet; thence S 43° 21' 22" E a distance of 205.43 feet to the East Line of said Sec. 10; thence S 43° 21' 22" E a distance of 448.50 feet to the westerly ROW line of County Road; thence continuing S 43° 21' 22" E a distance of 33.19 feet to the center line of County Road; thence S 40° 31' 06" W upon and along Center Line of County Road a distance of 527.18 feet to the point of beginning.

AND
A tract of land located in part of the Northeast Quarter (NE1/4) in Section Ten (10), Township Fourteen (14) North, Range Ten (10) West of the 6th P.M., Howard County, Nebraska, and more particularly described as follows: Commencing at the East 1/4 corner of Sec. 10-T14N-R10W; thence on an assumed bearing of N 00° 50' 34" E upon and along the East line of the NE1/4 a distance of 734.58 feet; thence S 40° 31' 06" W a distance of 103.99 feet to a point of curvature; thence around a curve in a clock wise direction having a delta angle of 01° 55' 18", a radius of 835.00 feet, and a chord bearing of S 41° 28' 45" W with a chord distance of 28.04 feet to a point on the North Right-of-Way (ROW) line of US Highway 281; thence S 60° 26' 44" W upon and along said US Hwy 281 North ROW line a distance of 145.76 feet to the northerly ROW line of County Road; thence continuing S 60° 26' 44" W upon and along said US Hwy 281 North ROW line a distance of 232.63 feet; thence continuing S 60° 26' 44" W upon and along said ROW line a distance of 41.18 feet to a point on the Easterly ROW line of US Highway 281; thence N 29° 00' 23" W upon and along said Easterly ROW line a distance of 401.12 feet; thence N 43° 21' 22" W upon and along said Easterly ROW line a distance of 398.72 feet to a point; thence N 55° 08' 12" E a distance of 647.91 feet; thence N 65° 08' 12" E a distance of 647.91 feet; thence N 55° 08' 12" E a distance of 260.59 feet; thence N 52° 46' 10" E a distance of 133.71 feet; thence N 36° 13'49" W a distance of 314.52 feet; thence S 60° 14'25" W distance of 135.88 feet; thence S 63° 29' 51" W distance of 280.59 feet; thence S 54° 23' 01" W a distance of 267.53 feet; thence S 33° 07' 18" W a distance of 427.30 feet to said East ROW line; thence S 43° 21'22" E a distance of 170.55 feet to the point of beginning.

DEDICATION OF PLAT

Know all Men by these presents, James A. Rice and Dianne S. Rice, husband and wife, being the owners of the land described hereon has caused the same to be Surveyed, Platted and Designated as the RICE'S SUBDIVISION located in Howard County, Nebraska as shown on the accompanying Plat thereof and that the foregoing subdivided lot is more particularly described in the description hereon as appears on this Plat is made with the free consent and in accordance with the desires of the undersigned owners.

In witness thereof I have affixed my signature hereto at _____
Nebraska on _____ 20____

James A. Rice
Dianne S. Rice

State of Nebraska)
County of _____) SS
Acknowledgment of Notary

on this _____ Day of _____ 20____
before me, a Notary Public in and for said County and State, came James A. Rice and Dianne S. Rice, to me personally known to be the same, acknowledged the execution of the same in testimony thereof, I have hereunto set my hand and affixed my Notary Seal the Day and Year above written.

Notary Public
My Comm. Expires: _____

CITY OF SAINT PAUL APPROVAL

This Plat of RICE'S SUBDIVISION has been submitted to and approved by the City of Saint Paul on _____ 20____
Mayor _____
City Clerk _____

APPROVAL OF PLANNING AND ZONING COMMISSION

This Plat of RICE'S SUBDIVISION has been submitted to and approved by the City of Saint Paul Planning and Zoning Commission on _____ 20____

COUNTY TREASURERS CERTIFICATE

I hereby certify that on this _____ day of _____ 20____, the records of my office show no taxes due or delinquent upon the property described in the Legal Description on this plat.

County Treasurer _____