

Regular Board of Education Meeting

Monday, November 12, 2018 7:30 PM

Boone Central High School Library
605 South 6th St.
Albion, NE 68620

Justin Frey: Absent

Ed Knott: Present

Sean Kohl: Present

Patti Meyer: Present

Tim Stopak: Present

Darren Wright: Present

1. Open the Meeting - Call to Order
2. Approval of Absent Board Members if Necessary

Motion to approve the absence of Board Member Justin Frey. This motion, made by Darren Wright and seconded by Sean Kohl, Passed.

Ed Knott: Yea, Sean Kohl: Yea, Patti Meyer: Yea, Tim Stopak: Yea, Darren Wright: Yea
Yea: 5, Nay: 0

3. Welcome Guests
4. Consent Agenda

Motion to approve the Consent Agenda and the bills, and to authorize the Board President and Treasurer to sign and validate all the checks as presented. This motion, made by Darren Wright and seconded by Ed Knott, Passed.

Ed Knott: Yea, Sean Kohl: Yea, Patti Meyer: Yea, Tim Stopak: Yea, Darren Wright: Yea
Yea: 5, Nay: 0

1. Meeting Agenda and Previous Meeting Minutes
2. Bill Roster and Financial Reports
5. Board Committee Reports
6. Administrative Reports
 1. Elementary Principal
First grade students were able to participate in virtual field trip with Omaha's Henry Doorly Zoo and UNL State Museum.
 2. Middle School Principal
Middle School Character Retreat was held on October 22nd. Keynote speaker, Scott Backovich, presented about being a person of good character. Winter sports have begun; 24 girls out for basketball and 20 wrestlers. NSCAS scores have been released to schools; public embargo will be lifted in December.
 3. High School Principal
35 students were recognized for perfect attendance for the first quarter. High school students will take part in the County Government Day on November 14th. All 9th and 10th graders will attend annual college visits at UNL, UNK and CCC in November. Annual Veteran's Day program was held on November 12th; Blake Trombley was keynote speaker.
 4. Activities Director
 5. Superintendent
The greenhouse project is complete. \$150,000 reimbursement from Albion Education Foundation has been requested. Other funds for the project were \$23,320 (WindFarm Grant) and \$7,207 (Building Fund). Flagpole lighting will be added to front of school; Kallhoff Electric will install. Sentinel building will be moved to northeast corner of Mason's lot. Materials will arrive mid-December. Chuck Rolf will erect the building; Kallhoff Electric will run electrical supply. ESSA/Title IIA Grant application submitted for \$26,500 to sustaining 60 minute PLC time each week dedicated to professional and instructional needs of our teachers and leaders, student and teacher accountability, and improving academic achievement.

ESSA Grant Funding - Grant funds must be spent on:

- increasing student achievement consistent with the challenging State academic standards (See Guaranteed Viable Curriculum below)
- improving the quality and effectiveness of teachers, principals, and other school leaders
- increasing the number of teachers, principals and other school leaders who are effective in improving student academic achievement in schools

Grant funds total \$26,500 and will be specifically spent on:

- Sustaining 60 minute PLC time each week dedicated to professional and instructional needs of our teachers and leaders. Research indicates that effective professional

development must be sustained and include ongoing support.

- Establishing a Guaranteed Viable Curriculum anchored to the Nebraska State Standards.
- Professional Development that will directly support instructional practices based on needs assessment.
- Developing assessments, grading practices, student accountability and teacher accountability.
- Developing a school-wide (evidence model) data collection system - How will effectiveness and rigor be examined? (Who, What, Where, When, and How of Data Collection) How will effective instruction be examined?
- Teacher and Principal Accountability System - iObservation - Supervising and supporting effective teaching in every classroom.

Guaranteed & Viable Curriculum

Our PLC focus:

- is to bring clarity, coherence, and precision to our classrooms.
- is to provide a rigorous curriculum that is clear.
- is to create a compact list of learning expectations for students at each grade and a list of examples that will identify when our students are proficient.

Our PLC groups will identify desired results at each level or within each course.

- ~ What should our students know, understand, and be able to do?
- ~ What content is worthy of understanding?
- ~ What enduring understandings are desired?
- ~ What essential questions will be explored?

As district leaders it is our responsibility to:

- ~ ensure our teachers know the intentions and success criteria of their lessons.
 - ~ ensure our teachers know how well they are attaining the criteria for all students.
 - ~ ensure our teachers know what to do next if there is a gap between students knowledge and understanding.
- *The PLC's are an opportunity for our teachers to talk about teaching in a safe and collaborative environment.

Our intent is to be a high-reliability school by providing all students with a guaranteed and viable curriculum focused on enhancing student learning.

- ~ Curriculum is focused enough that it can be adequately addressed in the time teachers have available.
- ~ All students have the opportunity to learn the critical content of the curriculum.
- ~ Individual teachers do not have the option to disregard or replace content that has been designated as essential.

7. Public Comment

8. Action Items

1. Board Policy Revisions

Approve policies. This motion, made by Sean Kohl and seconded by Tim Stopak, Passed. Ed Knott: Yea, Sean Kohl: Yea, Patti Meyer: Yea, Tim Stopak: Yea, Darren Wright: Yea
Yea: 5, Nay: 0

Revisions were made to policy 3101 School Meal Program, 3405 Use of Drug Detection Dogs, 4332 Use of Social Media, 5001 Admission Requirements, 5002 Immunizations, 5005 Part-time Enrollment, 5008 Student Transfer Nebraska Enrollment Option Program, and 5300 Student Discipline.

2. Adoption of Nebraska's College and Career Ready Science Standards

Motion to adopt the Nebraska College and Career Ready Standards for Science. This motion, made by Darren Wright and seconded by Ed Knott, Passed.

Ed Knott: Yea, Sean Kohl: Yea, Patti Meyer: Yea, Tim Stopak: Yea, Darren Wright: Yea
Yea: 5, Nay: 0

9. Next Meeting Date

Monday, December 10th @ 7:30 pm - Boone Central Middle School Library

10. Questions by the Media

11. Closed Session

12. Feasibility Study

13. Adjournment

The meeting was adjourned at 8:29 p.m.

Chairperson

Superintendent

Regular Board of Education Meeting

Monday, October 8, 2018 7:30 PM
Boone Central High School Art Room
605 S. 6th Street
Albion, Nebraska 68620

1. Opening the Meeting - Call to Order

Motion to approve the meeting open and properly posted by advance notice. This motion, made by Tim Stopak and seconded by Sean Kohl, Passed.

Justin Frey: Yea, Ed Knott: Yea, Sean Kohl: Yea, Patti Meyer: Yea, Tim Stopak: Yea, Darren Wright: Yea

Yea: 6, Nay: 0

2. Approval of Absent Board Members if Necessary

3. Welcome Guests

4. Consent Agenda

Motion to approve the Consent Agenda and the bills, and to authorize the Board President and Treasurer to sign and validate all the checks as presented. This motion, made by Patti Meyer and seconded by Darren Wright, Passed.

Justin Frey: Yea, Ed Knott: Yea, Sean Kohl: Yea, Patti Meyer: Yea, Tim Stopak: Yea, Darren Wright: Yea

Yea: 6, Nay: 0

4.1. Meeting Agenda and Previous Meeting Minutes

4.2. Bill Roster and Financial Reports

5. Board Committee Reports

6. Administrative Reports

6.1. Elementary Principal

Teachers from the elementary, middle school and high school presented on the Wednesday morning PLC's; thanking the board for the opportunity to collaborate. 97% of elementary parents attended Parent-Teacher Conferences in September.

6.2. Middle School Principal

86% of Middle School parents attended Parent Teacher Conferences.

6.3. High School Principal

78% of High School parents attended Parent-Teacher Conferences.

6.4. Activities Director

6.5. Superintendent

6.5.1. Phone, Intercom, and Page Systems

There are still issues with the bells and intercom messages sounding in the appropriate classrooms and hallways. All wiring will be checked over fall break on October 19th.

7. Public Comment

8. Action Items

8.1. Resolution to Sell Real Estate Property #1 0.5 Acre Lot located on Fairview Street

Motion to approve resolution to accept offer of \$22,000 by Dustin Sears and to hereby authorize the Board President to execute the agreement and all other documents necessary to complete the sale of the Property #1 to the purchaser. This motion, made by Darren Wright and seconded by Ed Knott, Passed.

Justin Frey: Yea, Ed Knott: Yea, Sean Kohl: Yea, Patti Meyer: Yea, Tim Stopak: Yea, Darren Wright: Yea

Yea: 6, Nay: 0

Two sealed bids were received for Property #1.

8.2. Resolution to Sell Real Estate Property #2 located at 933 S. 1st Street

Motion to approve resolution to accept offer of \$65,000 from Brenda Blunt and to hereby authorize the Board President to execute the agreement and all other documents necessary to complete the sale of the Property #2 to the purchaser. This motion, made by Darren Wright and seconded by Justin Frey, Passed.

Justin Frey: Yea, Ed Knott: Yea, Sean Kohl: Yea, Patti Meyer: Yea, Tim Stopak: Yea, Darren Wright: Yea

Yea: 6, Nay: 0

Three sealed bids were received for Property #2.

8.3. Furnace and Lighting Replacement in Mason's Building

Motion to replace existing furnace, install A/C unit, and replace light fixtures in Mason's Building as presented. This motion, made by Tim Stopak and seconded by Sean Kohl, Passed. Justin Frey: Yea, Ed Knott: Yea, Sean Kohl: Yea, Patti Meyer: Yea, Tim Stopak: Yea, Darren Wright: Yea
Yea: 6, Nay: 0

8.4. Athletic Trainer Employee Lease Agreement

Motion to approve Athletic Trainer Lease Agreement with Columbus Community Hospital and Newman Grove Public Schools as presented. This motion, made by Sean Kohl and seconded by Darren Wright, Passed.

Justin Frey: Yea, Ed Knott: Yea, Sean Kohl: Yea, Patti Meyer: Yea, Tim Stopak: Yea, Darren Wright: Yea
Yea: 6, Nay: 0

Prior Athletic Trainer Lease Agreement was held between Columbus Community Hospital and the Boone County Health Center. Amended Agreement is now between Columbus Community Hospital, Boone Central School District, and Newman Grove School District. Boone County Health Center will continue to support the athletic trainer program as in the past. The Board of Education recognized and expressed gratitude to the Boone County Health Center for their continued support of the program.

8.5. Boone Central Newman Grove Athletic Coop Agreement Amendment

Motion to approve amendment of Boone Central Newman Grove Athletic Coop Agreement reflecting the continued use of "Boone Central" on the wrestling uniforms to be replaced this fall. This motion, made by Ed Knott and seconded by Tim Stopak, Passed.

Justin Frey: Yea, Ed Knott: Yea, Sean Kohl: Yea, Patti Meyer: Yea, Tim Stopak: Yea, Darren Wright: Yea
Yea: 6, Nay: 0

8.6. Suicide Prevention Policy

Motion to approve Suicide Prevention Training Policy #4321 as presented. This motion, made by Patti Meyer and seconded by Sean Kohl, Passed.

Justin Frey: Yea, Ed Knott: Yea, Sean Kohl: Yea, Patti Meyer: Yea, Tim Stopak: Yea, Darren Wright: Yea
Yea: 6, Nay: 0

8.7. Flag Pole Lighting

Motion to allow facility committee to make final decision regarding flag pole lighting after all quotes are received. This motion, made by Justin Frey and seconded by Patti Meyer, Passed.

Justin Frey: Yea, Ed Knott: Yea, Sean Kohl: Yea, Patti Meyer: Yea, Tim Stopak: Yea, Darren Wright: Yea
Yea: 6, Nay: 0

8.8. Sentinel Building

Motion to allow facility committee to accept and determine sub-contractors for relocating Sentinel building after review of all quotes for concrete, building materials, electrical, and labor.

This motion, made by Sean Kohl and seconded by Tim Stopak, Passed.

Justin Frey: Yea, Ed Knott: Yea, Sean Kohl: Yea, Patti Meyer: Yea, Tim Stopak: Yea, Darren Wright: Yea

Yea: 6, Nay: 0

9. Closed Session

Motion to enter into closed session at 9:04 p.m. This motion, made by Darren Wright and seconded by Tim Stopak, Passed.

Justin Frey: Yea, Ed Knott: Yea, Sean Kohl: Yea, Patti Meyer: Yea, Tim Stopak: Yea, Darren Wright: Yea

Yea: 6, Nay: 0

Motion to re-enter regular session at 10:04 p.m. This motion, made by Patti Meyer and seconded by Ed Knott, Passed.

Justin Frey: Yea, Ed Knott: Yea, Sean Kohl: Yea, Patti Meyer: Yea, Tim Stopak: Yea, Darren Wright: Yea

Yea: 6, Nay: 0

10. Next Meeting Date

Regular Board of Education Meeting - Monday, November 12, 2018 @ 7:30 p.m. - Boone Central High School Library

11. Questions by the Media

12. Adjournment

Meeting adjourned at 10:05 p.m.

Chairperson

Superintendent

Fund: 05 ACTIVITIES FUND

<u>Chart of Account Number</u>	<u>Chart of Account Description</u>	<u>Beginning Balance</u>	<u>Expenses</u>	<u>Revenues</u>	<u>Balance Change</u>	<u>Balance</u>
05 704 0101	BC CLUB	920.47	0.00	909.75	0.00	1,830.22
05 704 0102	ACADEMIC HONORS	5,143.40	1,588.70	56.00	0.00	3,610.70
05 704 0104	ACTIVITY INTEREST	10,464.65	0.00	173.95	0.00	10,638.60
05 704 0105	ACTIVITY TICKET	14,369.92	0.00	315.00	0.00	14,684.92
05 704 0106	CLASS OF 2014	1,824.51	0.00	0.00	0.00	1,824.51
05 704 0108	AG SHOP	86.62	0.00	0.00	0.00	86.62
05 704 0110	SINGING ACROSS NEBRASKA	162.18	0.00	0.00	0.00	162.18
05 704 0111	CONCESSIONS	5,388.60	3,189.85	4,820.13	0.00	7,018.88
05 704 0113	ATHLETICS	(1,335.07)	5,663.57	2,231.00	0.00	(4,767.64)
05 704 0114	BAND	3,508.41	267.00	172.25	0.00	3,413.66
05 704 0116	CLOSE UP FUND RAISER	360.36	0.00	0.00	0.00	360.36
05 704 0118	CLASS OF 2017	3,755.20	0.00	0.00	0.00	3,755.20
05 704 0119	CHEERLEADERS	2,684.67	7.99	1,150.73	0.00	3,827.41
05 704 0120	CHORAL CLINIC	7,493.38	2,481.00	0.00	0.00	5,012.38
05 704 0121	STUDENT CHROMEBOOKS	7,362.30	0.00	0.00	0.00	7,362.30
05 704 0125	CROSS COUNTRY COACH ACCT	(226.00)	0.00	0.00	0.00	(226.00)
05 704 0126	JEANS ON FRIDAY SCHOLARSHIP	320.00	0.00	10.00	0.00	330.00
05 704 0127	COFFEE FUND	313.55	282.56	150.00	0.00	180.99
05 704 0129	CLASS OF 2011	466.99	0.00	0.00	0.00	466.99
05 704 0130	FBLA	1,188.15	230.46	741.00	0.00	1,698.69
05 704 0131	KEY FOB DEPOSIT	10.00	0.00	0.00	0.00	10.00
05 704 0132	FFA	18,372.37	2,869.90	1,810.00	0.00	17,312.47
05 704 0133	FCCLA	(4,663.74)	577.00	390.00	0.00	(4,850.74)
05 704 0134	JEFF BUSSEY MEMORIAL	535.00	0.00	0.00	0.00	535.00
05 704 0135	CLASS OF 2021	1,375.00	0.00	0.00	0.00	1,375.00
05 704 0136	HONOR SOCIETY	893.82	0.00	0.00	0.00	893.82
05 704 0137	CLASS OF 2018	225.42	0.00	0.00	0.00	225.42
05 704 0139	PARENT TEACHER ORGANIZATION	3.51	2,087.36	2,087.57	0.00	3.72
05 704 0140	ALBION CIRCLE OF FRIENDS	65.62	0.00	0.00	0.00	65.62
05 704 0141	LIBRARY	1,139.27	0.00	0.00	0.00	1,139.27
05 704 0143	MISCELLANEOUS	650.49	7,072.15	3,835.02	0.00	(2,586.64)
05 704 0144	BOOSTER CLUB	(40.39)	0.00	994.00	0.00	953.61
05 704 0145	CLASS OF 2019	6,049.55	0.00	0.00	0.00	6,049.55
05 704 0147	SOFTBALL COACH ACCT	5,698.57	223.42	196.00	0.00	5,671.15
05 704 0148	ATHLETIC DIRECTOR ACCOUNT	1,683.84	141.71	0.00	0.00	1,542.13
05 704 0149	SADD	3,735.16	1,399.77	955.00	0.00	3,290.39
05 704 0150	VOLLEYBALL COACH ACCT	8,545.25	0.00	0.00	0.00	8,545.25
05 704 0152	SCHOLARSHIP	1,222.61	0.00	0.00	0.00	1,222.61

Fund: 05 ACTIVITIES FUND

<u>Chart of Account Number</u>	<u>Chart of Account Description</u>	<u>Beginning Balance</u>	<u>Expenses</u>	<u>Revenues</u>	<u>Balance Change</u>	<u>Balance</u>
05 704 0153	SCHOLARSHIP CD	5,702.13	0.00	0.00	0.00	5,702.13
05 704 0154	SPEECH	3,067.78	463.94	0.00	0.00	2,603.84
05 704 0155	ONE ACT	10,132.91	8,203.08	223.00	0.00	2,152.83
05 704 0156	STUDENT COUNCIL	678.36	564.44	1,558.00	0.00	1,671.92
05 704 0157	CULTURE CLUB	1,697.79	67.00	55.00	0.00	1,685.79
05 704 0158	CRUISIN CARDS	3,549.24	0.00	0.00	0.00	3,549.24
05 704 0159	A-P HOOPS COACH ACCT	7,456.26	0.00	0.00	0.00	7,456.26
05 704 0160	FOOTBALL COACH ACCT	2,837.56	5,191.68	2,126.00	0.00	(228.12)
05 704 0161	VOCAL MUSIC	11,337.60	2,655.00	0.00	0.00	8,682.60
05 704 0162	CLASS 2013	125.57	0.00	0.00	0.00	125.57
05 704 0163	WOOD SHOP	451.34	1,002.50	395.80	0.00	(155.36)
05 704 0164	GIRLS BASKETBALL COACH ACCT	1,088.79	0.00	0.00	0.00	1,088.79
05 704 0165	KOHTZ MEMORIAL	290.00	0.00	0.00	0.00	290.00
05 704 0166	ELEMENTARY ART FUND RAISING	632.70	0.00	0.00	0.00	632.70
05 704 0167	ELEM LIBRARY ACCOUNT	858.53	0.00	0.00	0.00	858.53
05 704 0169	CLASS OF 2012	564.58	0.00	0.00	0.00	564.58
05 704 0170	MISC T-SHIRT ACCOUNT	(359.60)	(29.00)	0.00	0.00	(330.60)
05 704 0171	ART CLUB ACTIVITY ACCOUNT	188.41	0.00	105.00	0.00	293.41
05 704 0172	CLASS OF 2020	3,130.00	0.00	350.00	0.00	3,480.00
05 704 0173	CLASS OF 2008	811.25	0.00	0.00	0.00	811.25
05 704 0175	CLASS OF 2016	1,664.14	0.00	0.00	0.00	1,664.14
05 704 0176	CLASS OF 2010	593.23	0.00	0.00	0.00	593.23
05 704 0177	CLASS OF 2009	768.84	0.00	0.00	0.00	768.84
05 704 0178	POST PROM	6,107.06	0.00	0.00	0.00	6,107.06
05 704 0179	DISTRICT 5 FCCLA	3,339.64	325.20	2,920.00	0.00	5,934.44
05 704 0180	PATHWAYS	39.12	0.00	0.00	0.00	39.12
05 704 0185	INSTRUMENT RENTAL	13,863.43	5.40	0.00	0.00	13,858.03
05 704 0188	DANCE SQUAD	(343.51)	2,120.85	360.00	0.00	(2,104.36)
05 704 0190	MONSANTO GRANT	6,690.69	2,649.36	0.00	0.00	4,041.33
05 704 0191	CENTRACARD/ALBACARD	4,725.62	0.00	1,610.00	0.00	6,335.62
05 704 0192	MS VOLLEYBALL COACH ACCT	1,033.60	83.00	140.00	0.00	1,090.60
05 704 0193	COUNSELOR RESOURCE FUND	492.28	0.00	0.00	0.00	492.28
05 704 0195	CARDINAL KIDS CLUB	28,949.57	0.00	0.00	0.00	28,949.57
05 704 0196	TRACK COACH ACCT	3,721.14	0.00	0.00	0.00	3,721.14
05 704 0197	GREEN HOUSE	(119,654.23)	42,361.87	0.00	0.00	(162,016.10)
05 704 0198	TRADITIONS	(812.37)	1,224.89	0.00	0.00	(2,037.26)
05 704 0199	SCORVISION	14,000.00	0.00	2,500.00	0.00	16,500.00
05 704 0200	FUND BALANCE/MUSICAL	0.00	0.00	7,720.00	0.00	7,720.00

Fund: 05 ACTIVITIES FUND

<u>Chart of Account Number</u>	<u>Chart of Account Description</u>	<u>Beginning Balance</u>	<u>Expenses</u>	<u>Revenues</u>	<u>Balance Change</u>	<u>Balance</u>
05 704 0227	MS CIRCLE OF FRIENDS	76.27	0.00	0.00	0.00	76.27
05 704 0228	BAND UNIFORMS	4,507.71	0.00	0.00	0.00	4,507.71
05 704 2190	ATHLETICS	(2,696.00)	0.00	0.00	0.00	(2,696.00)
05 704 2191	HS FOOTBALL	3,067.00	2,177.49	2,533.00	0.00	3,422.51
05 704 2192	HS VOLLEYBALL	1,933.45	891.02	1,155.00	0.00	2,197.43
05 704 2193	HS CROSS COUNTRY	1,383.60	321.29	106.00	0.00	1,168.31
05 704 2194	HS SOFTBALL	493.50	1,767.78	954.00	0.00	(320.28)
05 704 2196	HS WRESTLING	(400.00)	200.00	545.00	0.00	(55.00)
05 704 2199	HS GIRLS GOLF	(737.35)	799.96	15.05	0.00	(1,522.26)
05 704 2201	HS BOYS BASKETBALL	(400.00)	0.00	0.00	0.00	(400.00)
05 704 4191	MS FOOTBALL	(1,709.22)	949.00	312.00	0.00	(2,346.22)
05 704 4192	MS VOLLEYBALL	(505.00)	110.00	324.00	0.00	(291.00)
05 704 4196	MS WRESTLING	0.00	0.00	0.00	0.00	0.00
05 704 5000	HOSTING DISTRICTS	0.00	526.00	0.00	0.00	(526.00)
Fund Total: 05		134,187.05	102,714.19	47,004.25	0.00	78,477.11

Activity Fund Balance Report - Summary - Exclude Encumbrances
 10/2018 - 10/2018

Fund: 09 PETERSBURG ACTIVITY FUND

<u>Chart of Account Number</u>	<u>Chart of Account Description</u>	<u>Beginning Balance</u>	<u>Expenses</u>	<u>Revenues</u>	<u>Balance Change</u>	<u>Balance</u>
09 804 0201	YEARBOOK	(3,038.72)	0.00	0.00	0.00	(3,038.72)
09 804 0211	CONSUMER SCIENCE	23.06	0.00	0.00	0.00	23.06
09 804 0212	STUDENT OF THE MONTH	94.89	0.00	0.00	0.00	94.89
09 804 0216	INTEREST	1,031.33	0.00	2.30	0.00	1,033.63
09 804 0217	MIDDLE SCHOOL	505.09	0.00	0.00	0.00	505.09
09 804 0218	MEDIA	1,318.48	0.00	0.00	0.00	1,318.48
09 804 0222	STUDENT COUNCIL	6,400.42	606.09	607.00	0.00	6,401.33
09 804 0224	MISC. ACTIVITY	1,629.45	0.00	0.00	0.00	1,629.45
Fund Total: 09		<u>7,964.00</u>	<u>606.09</u>	<u>609.30</u>	<u>0.00</u>	<u>7,967.21</u>

AUGUST 2018 HOT LUNCH BILLS -- ALBION/PETERSBURG

BEGINNING BANK BALANCE		\$19,233.40
Ahlstedt, Ann	\$41.00	
Babl, Adam	6.50	
Brown & Saenger	\$1,429.59	
Bruland, Kayla	\$5.80	
Criss Co Inc	\$70.00	
Culligan	\$35.46	
FeeZee	\$62.49	
Hiland Dairy	\$59.44	
Michael, Nikki	\$28.85	
Moore Medical Corp	\$14.16	
Nebraska Food Distribution	\$4,244.34	
Porter, JoAnn	\$57.75	
Pyramid School Products	\$11.67	
School Nutrition Association	\$50.50	
Wordware Inc.	\$427.45	
TOTAL	\$6,545.00	
Payroll	<u>\$4,707.91</u>	
TOTAL EXPENSES FOR AUGUST	\$11,252.91	
TOTAL DEPOSITS FOR AUGUST	<u>\$26,751.46</u>	
BANK BALANCE		\$34,731.95

SEPTEMBER 2018 HOT LUNCH BILLS -- ALBION/PETERSBURG

BEGINNING BANK BALANCE		\$34,731.95
Appeara	\$363.47	
Bernard Food Ind	874.36	
Bomgaars	\$14.99	
Cash-Wa Dist	\$9,431.75	
Criss Co Inc	\$328.75	
Culligan	\$68.86	
FeeZee	\$19.82	
Hiland Dairy	\$3,341.53	
Nebraska Food Distribution	\$4,000.69	
Pegler Sysco Food	\$6,176.68	
Rae Valley Market	\$37.45	
Thompson Co	\$408.30	
Thriftyway	\$107.73	
Venducation	\$39.00	
TOTAL	\$25,213.38	
Payroll	<u>\$18,745.71</u>	
TOTAL EXPENSES FOR SEPTEMBER	\$43,959.09	
TOTAL DEPOSITS FOR SEPTEMBER	<u>\$30,515.80</u>	
BANK BALANCE		\$21,288.66

OCTOBER 2018 HOT LUNCH BILLS -- ALBION/PETERSBURG

BEGINNING BANK BALANCE		\$21,288.66
Advanced Fire & Safety	\$170.00	
Appeara	\$312.05	
Bernard Food Ind	\$113.52	
Cash-Wa Dist	\$6,182.22	
Cullligan	\$35.46	
Feezee	\$10.00	
Hiland Dairy	\$4,510.51	
Nebraska Food Distribution	\$1,592.15	
NSNA District 4	\$24.00	
Pegler Sysco Food	\$3,885.75	
Rae Valley Market	\$32.29	
Thompson Co	\$565.17	
Thriftyway	\$51.92	
TOTAL	\$17,485.04	
Payroll	<u>\$19,781.41</u>	
TOTAL EXPENSES FOR OCTOBER	\$37,266.45	
TOTAL DEPOSITS FOR OCTOBER	<u>\$44,409.98</u>	
BANK BALANCE		\$28,432.19

HOT LUNCH REPORT
2018-2019

<u>MONTH</u>	<u>NUMBER OF MEALS</u>	<u>BEGINNING BALANCE</u>	<u>TOTAL INCOME</u>	<u>TOTAL EXPENSES</u>	<u>CLOSING BALANCE</u>
AUGUST	1,124 5,860	\$19,233.40	\$26,751.46	\$11,252.91	\$34,731.95
SEPTEMBER	1,636 7,849	\$34,731.95	#####	\$43,959.09	\$21,288.66
OCTOBER	1,916 9,769	\$21,288.66	#####	\$37,266.45	\$28,432.19
NOVEMBER					
DECEMBER					
JANUARY					
FEBRUARY					
MARCH					
APRIL					
MAY					
JUNE					
JULY					

Boone Central Schools
 11/09/2018 3:01 PM

Board Report

<u>Vendor ID</u>	<u>Vendor Name</u>		<u>Amount</u>	<u>Invoice</u>	<u>Description</u>	
Checking		1				
Checking		1				
ACT	ACT		611.00	32087102	SUPPLIES	
					Vendor Total:	611.00
AIRWOLF3D	Airwolf 3D		419.00	10970	Ind Arts Supplies	
					Vendor Total:	419.00
ALBIONNEWS	ALBION NEWS		867.42	10/18 Stmt	Advertising	
					Vendor Total:	867.42
ALBRACHTDI	ALBRACHT DISPOSAL SERVICE INC		694.38	8/31-9/13/18	WATER/GARBAGE	
					Vendor Total:	694.38
APPEARA	APPEARA		231.52	10/18 Stmt	Service Agreements	
APPEARA	APPEARA		592.03	10/2018 Stmt	Service Agreements	
					Vendor Total:	823.55
APPLIEDCON	APPLIED CONNECTIVE TECHNOLOGIES		150.00	108023	Telecommunications District	
APPLIEDCON	APPLIED CONNECTIVE TECHNOLOGIES		360.00	108131	Other Professional Services	
APPLIEDCON	APPLIED CONNECTIVE TECHNOLOGIES		195.00	108243	Other Professional Services	
					Vendor Total:	705.00
AXISCAPITA	AXIS CAPITAL		193.90	C5502-0058	COPIER RENTAL	
					Vendor Total:	193.90
BGBODYSHO2	B & G BODY SHOP		50.00	2730	Repairs	
BGBODYSHO2	B & G BODY SHOP		358.96	2739	Repairs	
					Vendor Total:	408.96
BLACKHILLS	Black Hills Energy		965.81	10/18 203 E Widaman	MS Natural Gas	
BLACKHILLS	Black Hills Energy		2,269.58	10/18 605 S 6th	Fuel	
BLACKHILLS	Black Hills Energy		19.74	10/18 644 S 6th St.	Fuel	
BLACKHILLS	Black Hills Energy		20.81	10/18 933 S 1st St	Fuel	
BLACKHILLS	Black Hills Energy		19.74	10/18 951 S 1st	Fuel	
BLACKHILLS	Black Hills Energy		169.97	10/18 Pathways	Pathways Fuel	
					Vendor Total:	3,465.65
BLICKARTMA	BLICK ART MATERIALS		598.30	340898	Art Supplies	
BLICKARTMA	BLICK ART MATERIALS		25.27	358449	Art Supplies	
					Vendor Total:	623.57
BOMGAARS	BOMGAARS		468.93	10/18 Stmt	Ag Supplies	
					Vendor Total:	468.93
BOONECENTR	BOONE CENTRAL ACTIVITY		2,396.79	10/18 Amazon	MS PE Supplies	
BOONECENTR	BOONE CENTRAL ACTIVITY		5,704.50	7/13/18	Supplies	
BOONECENTR	BOONE CENTRAL ACTIVITY		925.00	8/10/18	Supplies	
BOONECENTR	BOONE CENTRAL ACTIVITY		1,928.52	9/15 Amazon	Supplies	

Boone Central Schools
11/09/2018 3:01 PM

Board Report

<u>Vendor ID</u>	<u>Vendor Name</u>	<u>Amount</u>	<u>Invoice</u>	<u>Description</u>	
BOONECENTR	BOONE CENTRAL ACTIVITY	2,267.72	9/18 Stmt	Supplies	
BOONECENTR	BOONE CENTRAL ACTIVITY	450.00	Spring 2018	Repairs	
				Vendor Total:	13,672.53
BCHOTLUNCH	BOONE CENTRAL HOT LUNCH	510.15	10/18 CKC	Supplies-CKC	
BCHOTLUNCH	BOONE CENTRAL HOT LUNCH	1,181.30	10/18 Stmt	PRESCHOOL SUPPLIES	
BCHOTLUNCH	BOONE CENTRAL HOT LUNCH	37.50	10/24	Supplies	
				Vendor Total:	1,728.95
BOCOHEALTH	BOONE CO HEALTH CENTER	125.00	10/18 Stmt	PHYSICAL THERAPY	
				Vendor Total:	125.00
BOYSTOWN	Boys Town	2,323.05	NIA000169834	OTHER PROF/TECH SERVICES	
				Vendor Total:	2,323.05
BROOKLYNPU	BROOKLYN PUBLISHERS, LLC	151.65	45168	MS Speech Supplies	
				Vendor Total:	151.65
CEDARVALLE	CEDAR VALLEY LUMBER - ALBION	353.69	10/18 Stmt	HS Supplies	
				Vendor Total:	353.69
GIPHYSTH	CENTRAL NEBRASKA REHABILITATION SERVICES	2,801.50	9/18 Services	OCCUPATION THERAPY	
				Vendor Total:	2,801.50
CENTRALPAR	CENTRAL PARTS & MACHINE	125.65	002-106203	Repairs	
				Vendor Total:	125.65
CITYOFALBI	CITY OF ALBION	375.00	8017	Equipment Rental	
				Vendor Total:	375.00
CONNECTNOW	Connect Now, Inc	24.99	16969	SUPPLIES	
				Vendor Total:	24.99
DEPTOFHEAL	Dept. of Health & Human Services	140.00	2018-2020	DUES AND FEES	
				Vendor Total:	140.00
DOLLARGENE	DOLLAR GENERAL MSC-410526	180.95	10/17/18	Supplies	
				Vendor Total:	180.95
EAKESOFFIC	EAKES OFFICE SUPPLY	98.00	7624299-0	MS Copiers	
EAKESOFFIC	EAKES OFFICE SUPPLY	454.00	7624304-0	Elem Copier	
EAKESOFFIC	EAKES OFFICE SUPPLY	98.00	7624361-0	MS Copiers	
				Vendor Total:	650.00
EARLMAY	EARL MAY NURSERY	7.99	10/18 Stmt	Science Supplies	
				Vendor Total:	7.99
ESU6	EDUCATIONAL SERVICE UNIT #6	90.00	9/21/18	Professional Development	
				Vendor Total:	90.00
ELECCONTCO	ELECTRONIC CONTRACTING COMPANY	81.00	LN048017	Repairs	
				Vendor Total:	81.00

Boone Central Schools
11/09/2018 3:01 PM

Board Report

<u>Vendor ID</u>	<u>Vendor Name</u>	<u>Amount</u>	<u>Invoice</u>	<u>Description</u>	
EMCINSURAN	EMC INSURANCE	9,070.71	10/18 Stmt	Insurance	
				Vendor Total:	9,070.71
ESU7SPED	ESU #7-SPED	11,272.49	9/18	Purchased Services from ESU	
				Vendor Total:	11,272.49
ESU7TECH	ESU 7 TECHNOLOGY	37.50	4106	Tech Mainenance	
				Vendor Total:	37.50
FES	FES	2,600.00	18-19	Website/Messenger System	
				Vendor Total:	2,600.00
FLAGHOUSE	FLAGHOUSE	80.62	P07891740101 0	Preschool Supplies	
				Vendor Total:	80.62
FREMONTIND	Fremont Industries LLC	458.00	2018-35537- 00	HS Service Agreements	
				Vendor Total:	458.00
FRONTI	FRONTIER	547.18	10/18 Stmt	Telecommunications Albion	
				Vendor Total:	547.18
FRUHAUF	FRUHAUF UNIFORMS INC.	309.00	18I-11686	Band Supplies	
				Vendor Total:	309.00
GLASERCERA	GLASER CERAMICS	721.24	00037117	Art Supplies	
				Vendor Total:	721.24
GRAGERT	GRAGERT'S SHUR SAVE	9.18	10/18 4th Gr.	FOURTH GRADE SUPPLIES	
GRAGERT	GRAGERT'S SHUR SAVE	19.87	10/18 Stmt	Afterschool Supplies	
				Vendor Total:	29.05
GREATP	GREAT PLAINS COMMUNICATION	1,432.07	10/16/18	Telecommunications District	
				Vendor Total:	1,432.07
GREENTURF	GREENTURF UNDERGROUND SPRINKLERS	55.00	3214	Elem. Service Agreements	
				Vendor Total:	55.00
HARDNIC	Hardwick, Nicole	319.37	9/18	Mileage	
				Vendor Total:	319.37
HELENA	HELENA CHEMICAL CO	19.50	10/18 Stmt	MS Cust Supplies	
				Vendor Total:	19.50
HOMETOWNLE	Hometown Leasing	1,347.96	4th of mon- 0002	Copiers	
				Vendor Total:	1,347.96
JSAUTOREPA	J's Auto Repair, LLC	128.57	12376	Repairs	
JSAUTOREPA	J's Auto Repair, LLC	60.00	12377	Repairs	
JSAUTOREPA	J's Auto Repair, LLC	60.00	12392	Repairs	
JSAUTOREPA	J's Auto Repair, LLC	60.00	12393	Repairs	

Boone Central Schools
 11/09/2018 3:01 PM

Board Report

<u>Vendor ID</u>	<u>Vendor Name</u>	<u>Amount</u>	<u>Invoice</u>	<u>Description</u>	
				Vendor Total:	308.57
JOURNEYEDC	JourneyEd.com Inc.	2,449.00	10248693	Web-based Software	
				Vendor Total:	2,449.00
JWPEPPER	JW PEPPER & SON INC.	197.04	03588050	Music Supplies	
				Vendor Total:	197.04
KALLHOFFEL	KALLHOFF ELECTRIC	1,576.80	1276	Construction Services	
				Vendor Total:	1,576.80
KAVTIRELU	KAV TIRE & LUBE	100.00	202143	Repairs	
KAVTIRELU	KAV TIRE & LUBE	846.55	587462	Repairs	
				Vendor Total:	946.55
LEIFEL	LEIFELDS HARDWARE & FURNITURE	24.03	10/18 Stmt	MS Supplies	
				Vendor Total:	24.03
LOOKOUTBOO	LOOKOUT BOOKS	1,651.86	ARU0267993	HS Library Books & Periodicals	
				Vendor Total:	1,651.86
LOUPPO	LOUP POWER DIST	12,132.58	10/18	Electricity	
				Vendor Total:	12,132.58
MATHESONTR	MATHESON LINWELD	512.20	18474389	Welding Supplies	
MATHESONTR	MATHESON LINWELD	177.32	51378701	Welding Supplies	
				Vendor Total:	689.52
MCGRAW	MCGRAW-HILLSCHOOL EDUCATION HOLDINGS LLC	410.20	105942802001	TEXTBOOKS SEC	
				Vendor Total:	410.20
METALD	METAL DOOR AND HARDWARE	715.00	66110	SUPPLIES	
				Vendor Total:	715.00
MIDAME	MIDAMERICA BOOKS	770.72	457084	HS Library Books & Periodicals	
				Vendor Total:	770.72
MOLTMANUFA	MOLT MANUFACTURING, INC.	298.00	10/18 stmt	Supplies	
				Vendor Total:	298.00
NATGEO	NATIONAL GEOGRAPHIC SOCIETY	62.70	2018	Elementary Requisitions	
				Vendor Total:	62.70
NCECBVI	NCECBVI	8,750.00	T-265	Professional Educational Services	
				Vendor Total:	8,750.00
NEASSO	NE ASSOC OF SCHOOL BDS	1,294.00	INV-01658-D7N9M3	Training & Development	
NEASSO	NE ASSOC OF SCHOOL BDS	72.00	INV-01659-X8M8B3	Training & Development	
NEASSO	NE ASSOC OF SCHOOL BDS	314.00	INV-01664-B0W4G8	Training & Development	
				Vendor Total:	1,680.00

Board Report

<u>Vendor ID</u>	<u>Vendor Name</u>	<u>Amount</u>	<u>Invoice</u>	<u>Description</u>	
NEDOL	NE DOL/BOILER INSPECTION PROGRAM	150.00	111438	Inspection	
				Vendor Total:	150.00
OCCUPATION	Occupational Health Services	204.00	60164	Other Professional Services	
OCCUPATION	Occupational Health Services	252.00	60270	Other Professional Services	
				Vendor Total:	456.00
OFFICE	OFFICE NET	389.90	901793-0	GUIDANCE FURNITURE/EQUIPMENT	
OFFICE	OFFICE NET	2,738.00	903676-0	FURNITURE & EQUIPMENT	
OFFICE	OFFICE NET	331.82	906008-0	SUPPLIES	
				Vendor Total:	3,459.72
PAYFLEX	PAYFLEX SYSTEMS USA INC	100.00	October 2018	Other Health Benefits	
				Vendor Total:	100.00
PETTYCASH	PETTY CASH FUND	6,347.53	10/18 Receipts	Supplies	
				Vendor Total:	6,347.53
POPPLE	POPPLERS	57.44	2203801	MS Music Supplies	
POPPLE	POPPLERS	16.92	2209326	MS Music Supplies	
				Vendor Total:	74.36
POWERSCHOO	PowerSchool Group LLC	3,229.20	INV162646	Web-based Software	
				Vendor Total:	3,229.20
PRESTO	PRESTO X CO	80.00	1306436	HS Service Agreements	
PRESTO	PRESTO X CO	34.97	1306437	Pathways Maint. Agreements	
				Vendor Total:	114.97
QUILL	QUILL CORP	52.79	1623784	COMPUTER EQUIPMENT	
QUILL	QUILL CORP	190.95	1665445	Business Office Technology	
				Vendor Total:	243.74
RAEVALLEYM	RAE VALLEY MARKET	17.35	10/18 Stmt	MS Guidance Supplies	
				Vendor Total:	17.35
RAEVALLEYM	RAE VALLEY REPAIR	92.00	1719	Repairs	
RAEVALLEYM	RAE VALLEY REPAIR	97.50	1720	Repairs	
				Vendor Total:	187.50
SCHALKAUTO	SCHALK AUTO INC	65.00	39187	Repairs	
SCHALKAUTO	SCHALK AUTO INC	85.00	39192	Repairs	
SCHALKAUTO	SCHALK AUTO INC	174.99	39193	Repairs	
				Vendor Total:	324.99
SCHOOLSPEC	SCHOOL SPECIALTY	52.15	208121955618	Elementary Requisitions	
				Vendor Total:	52.15
SHOPKOSTOR	Shopko Stores Operating Co., LLC	131.36	10/18 Stmt	Supplies	
				Vendor Total:	131.36
SOLUTIONTR	Solution Tree	1,200.00	S204811	Contracted or Secured Services	
				Vendor Total:	1,200.00

Boone Central Schools
11/09/2018 3:01 PM

Board Report

<u>Vendor ID</u>	<u>Vendor Name</u>	<u>Amount</u>	<u>Invoice</u>	<u>Description</u>	
STAPLESADV	STAPLES ADVANTAGE	65.22	3392008240	Supplies	
STAPLESADV	STAPLES ADVANTAGE	48.27	3394615280	Elementary Requisitions	
				Vendor Total:	113.49
SUPPLYWORK	SupplyWorks	1,467.03	457539815	Supplies	
SUPPLYWORK	SupplyWorks	26.48	458649167	Supplies	
SUPPLYWORK	SupplyWorks	590.98	458649175	Supplies	
				Vendor Total:	2,084.49
TAESE	TAESE/USU	450.00	Trist_139	Employee Training & Development	
				Vendor Total:	450.00
TEACHERCRE	TEACHER CREATED RESOURCES	38.93	6029887	Elementary Requisitions	
				Vendor Total:	38.93
TEACHINGST	TEACHING STRATEGIES	168.00	0343219-IN	Preschool Supplies	
				Vendor Total:	168.00
THRIFTYWAY	THRIFTYWAY	30.51	10/18 BCS-BC Club	Afterschool Supplies	
THRIFTYWAY	THRIFTYWAY	14.65	10/18 CKC	Afterschool Supplies	
THRIFTYWAY	THRIFTYWAY	3.08	10/18 Stmt	SUPPLIES	
THRIFTYWAY	THRIFTYWAY	88.22	10/2018 Stmt	Science Supplies	
				Vendor Total:	136.46
TRUCKCENTE	TRUCK CENTER COMPANIES	1,520.50	369457	Repairs	
				Vendor Total:	1,520.50
USBANKEQUI	U.S. BANK EQUIPMENT FINANCE	360.03	MP7502-0010	COPIER RENTAL	
				Vendor Total:	360.03
VERIZON	VERIZON	284.94	10/18	Telecommunications District	
				Vendor Total:	284.94
VILPET	VILLAGE OF PETERSBURG	696.98	9/18 Stmt	MS Water&Garbage	
				Vendor Total:	696.98
VOLKMIC	Volker, Michael	47.96	11/2/18	Mileage	
				Vendor Total:	47.96
VOSSEL	VOSS LIGHTING	110.64	10189186-00	Supplies	
				Vendor Total:	110.64
WHITES	WHITE STAR OIL CO	5,060.42	10/18 Stmt	Gasoline & diesel fuel	
				Vendor Total:	5,060.42
WOODWORKER	WOODWORKER'S SUPPLY INC.	65.64	8938225-2	Ind Arts Supplies	
				Vendor Total:	65.64
ZABKA	ZABKA CONOCO SERVICE	1,837.62	10/18 Stmt	Repairs	
				Vendor Total:	1,837.62
Fund Total:					122,142.54
Checking Account Total:					122,142.54

GENERAL FUND

10/1/18 Balance			\$1,292,983.10
10/10/18	1800 CKC		\$2,678.74
10/16/18	3535 State of Nebraska - High Ability 18-19		\$5,046.00
10/17/18	1800 M. Petsche - #1 Payment on returned check (\$340 still owed)		\$50.00
10/17/18	1800 Wright - September payment		\$32.89
10/18/18	1920 TeamMates - reimb A. Temme March-September 2018		\$1,642.50
10/18/18	1990 BCBS- Premium Refund		\$589.50
10/18/18	5300 N. Paulson - whiteboards		\$50.00
10/18/18	1125 Antelope County - Motor Vehicle		\$51.16
10/18/18	1100 Antelope County - Taxes		\$804.45
10/18/18	3133 Antelope County - Nameplate (Wind Energy)		\$827.29
10/18/18	9000 Antelope County - Bond Fund		\$199.92
10/18/18	9000 Antelope County - transfer to Bond Fund		-\$199.92
10/18/18	1125 Boone County - Motor Vehicle		\$24,621.38
10/18/18	1110 Boone County - Taxes		\$220,995.40
10/18/18	3180 Boone County -Pro Rate		\$1,806.41
10/18/18	3133 Boone County -Nameplate (Wind Energy)		\$13,596.63
10/18/18	2110 Boone County - Fines		\$1,323.82
10/18/18	9000 Boone County - Bldg Fund		\$3.36
10/18/18	9000 Boone County - transfer to Bldg Fund		-\$3.36
10/31/18	3110 State of Nebraska - State Aid		\$32,184.00
10/31/18	5690 Nance County - Barb Foland jury duty		\$35.00
10/31/18	1510 Interest		\$2,217.71
	Total Receipts		\$308,552.88
	Balance and Receipts		\$1,601,535.98
	Disbursements:		
	October payroll and bills		\$723,304.72
	NPERS adjustment		\$463.13
			\$723,767.85
10/31/18 Balance			\$877,768.13
	Premier Money Market Account		
	10/1/18 Beginning Balance		\$805,514.27
	Interest		1,471.11
	Transfer to General Fund		
	10/31/18 Ending Balance		\$806,985.38
	Total General Fund		\$1,684,753.51
	October Payroll		\$630,526.87
	October Bills		\$92,777.85
	Total		\$723,304.72

DEPRECIATION FUND

10/1/18 Balance		\$1,173,460.51
Receipts:		
Checking interest	\$2,143.77	
Transfer from General Fund		
Total Receipts		\$2,143.77
Check # Disbursements:		
332 SchoolsIn - Classroom furniture	\$3,190.68	
	Total Disbursements	\$3,190.68
10/31/18 Balance		\$1,172,413.60

Depreciation Budget 18-19	\$1,236,031.00	
YTD Expenses	\$42,903.08	
Balance		\$1,193,127.92

BUILDING FUND

10/1/2018 Balance		\$472,930.14
Receipts:		
Co. Treas-Taxes	\$3.36	
Antelope Co - Taxes		
Checking interest - Cornerstone	\$788.26	
Total Receipts		\$791.62
Disbursements:		
949 Boone County Clark - Title Insurance Mason Building	\$10.00	
950 Albion Masonic Lodge - purchase building	\$100,000.00	
951 Schact Abstract & Title Company - Mason building Owner Policy	\$407.50	
952 Boone Central Activity - Room signs	\$881.65	
953 OfficeNet - MS Principal furniture	\$392.70	
		-\$101,691.85
10/31/18 Balance		\$372,029.91

Building Fund Budget 18-19	\$663,584.00	
YTD Expenses	\$114,754.89	
Balance		\$548,829.11

BOND FUND (changed to repayment of bonds issued)

10/1/18 Beginning Balance		\$849,530.78
Boone Co. Treasurer -	\$28,965.16	
Antelope Co. Treasurer	\$199.92	
Interest	\$1,574.05	
Total Receipts		\$30,739.13
Disbursements:		
	Total Disbursements	\$0.00
10/31/18 Balance		\$880,269.91

Batch Description: 10-18 Petty Cash
Checking Account: 11

Petty Cash

Processing Month: 10/2018

<u>Check/Reference Number</u>	<u>Description</u>	<u>Date</u>	<u>Amount</u>
	Statement Balance	10/31/2018	32,802.59

Outstanding Checks

<u>Check/Reference Number</u>	<u>Description</u>	<u>Date</u>	<u>Amount</u>
7389	ALBION CHAMBER OF COMMERCE	01/05/2018	15.00
7826	ALBION POST OFFICE	09/21/2018	225.00
7830	NAEA DISTRICT 7	09/30/2018	130.00
7835	CNFL	10/17/2018	125.00
7837	Seaman Family Petting Zoo	10/22/2018	25.00
7839	NENSSA	10/22/2018	25.00
7844	Tanner Schutt	10/24/2018	308.47
7845	Jen Fistler	10/24/2018	262.93
7846	CENTRAL CITY HIGH SCHOOL	10/29/2018	50.00
7847	PITNEY BOWES PURCHASE POWER	10/29/2018	705.50
7848	THRIFTYWAY	10/29/2018	49.88
7849	Pamela Young	10/29/2018	10.28
7850	Stephanie Banzhaf	10/29/2018	148.13
7851	DOANE COLLEGE	11/02/2018	75.00
		Total:	<u>2,155.19</u>

<u>Statement Balance</u>	<u>Outstanding Total</u>	<u>Balance on Books</u>	<u>Cash Account Balance</u>
32,802.59	(2,155.19)	30,647.40	(71,408.81)

Cleared Automatic Payment Total:
 Cleared Checks Total: 216,121.95
 Cleared Direct Deposit Total:
 Cleared Void Total: 172.25
 Cleared Deposit Total: 112,650.65
 Cleared Manual Journal Entries Total: (104,238.32)
 Cleared Sales Journal Total:

Cash Receipt Listing by Cash Receipt Date
October 2018 Petty Cash

<u>Receipt Number</u>	<u>Received From</u>	<u>Receipt Date</u>	<u>Cash Receipt Description</u>	<u>Chart of Account Number</u>	<u>Detail Description</u>	<u>Amount</u>
Batch Description: PETTY CASH RECURRING						
				Processing Month: 10/2018		
	BCS BOONE CENTRAL SCHOOL	10/18/2018	LTD	11 1100 211 000 0000 0 000	LTD	2,116.60
	BCS BOONE CENTRAL SCHOOL	10/18/2018	REIMBURSE PETTY CASH	11 9000	REIMBURSE PETTY CASH	3,886.17
	BCS BOONE CENTRAL SCHOOL	10/18/2018	HEALTH INSURANCE	11 9000 211 000 0000 0 000	HEALTH INSURANCE	103,425.43
	BCS BOONE CENTRAL SCHOOL	10/18/2018	PAYFLEX	11 9000 461 000 0000 0 000	PAYFLEX	3,038.32
					Cash Receipt Date: 10/18/2018	<u>112,466.52</u>
	CORNERSTON CORNERSTONE BANK - ALBION	10/31/2018	CHECKING INTEREST	11 1510	CHECKING INTEREST	184.13
					Cash Receipt Date: 10/31/2018	<u>184.13</u>

Summary Totals

<u>Account Type</u>		<u>Cash Accounts</u>		<u>Receivable Accounts</u>
Subtotal Revenue	4,070.30	11 101		112,650.65
Subtotal Expense	108,580.35		Total:	<u>112,650.65</u>
Subtotal General Ledger				
Total:	<u>112,650.65</u>			

Invoice Listing - Summary
October 2018 Petty Cash

Vendor ID	Vendor Name	Invoice Number	Description	Invoice Date	Check Date	Checking Account ID	Check Number	Invoice Amount
Batch Description: 10/18 Petty Cash		Processing Month: 10/2018						
BANZSTE	Banzhaf, Stephanie	10/17-10/18	TPRS Conf.-Mileage	10/29/2018	10/29/2018	11	7850	148.13
BLUECROSSB	BLUE CROSS BLUE SHIELD OF NEBRASKA	11/18	Health Ins.	10/22/2018	10/22/2018	11	7841	101,979.50
BOCOFITNES	BOONE CO FITNESS CENTER	18-19	19 Members	10/22/2018	10/22/2018	11	7840	3,471.87
CCHIGHSCHO	CENTRAL CITY HIGH SCHOOL	11/3/18	Quiz Bowl	10/29/2018	10/29/2018	11	7846	50.00
CNFL	CNFL	18-19	Membership	10/17/2018	10/17/2018	11	7835	125.00
DOANECOLLE	DOANE COLLEGE	11/3/18	Fall Festival	10/31/2018	11/02/2018	11	7851	75.00
DURHAMMUSE	Durham Museum	10/16/18	WWI Field Trip	10/15/2018	10/15/2018	11	7834	50.00
ELKHORNVAL	ELKHORN VALLEY	10/2018	MS Choral Clinic	10/15/2018	10/15/2018	11	7833	65.00
FISTLER	Fistler, Jen	5/22/18-8/13/18	Summer Services	10/24/2018	10/24/2018	11	7845	282.93
MADISONNAT	MADISON NATIONAL LIFE INSURANCE CO INC.	10/18 & 11/18	Long Term Disability	10/22/2018	10/22/2018	11	7842	4,233.20
MARTIN	MARTIN TREE SERVICE	10/5/18	Tree Removal Pathways	10/08/2018	10/08/2018	11	7831	450.00
MILLDONROB	Miller, Donna	9/6-10/3/18	Mileage	10/22/2018	10/22/2018	11	7838	444.72
NEFCCLA	NE FCCLA	2018	FACS Fall Workshop	10/24/2018	10/24/2018	11	7843	15.00
NEBRASKAEX	Nebraska Extension - Antelope County	10/11/18	4th Grade Field Trip	10/10/2018	10/10/2018	11	7832	36.00
NENSSA	NENSSA	18-19	Region 3 dues	10/22/2018	10/22/2018	11	7839	25.00
PITNEYBOWE	PITNEY BOWES PURCHASE POWER	9/20/18	Postage	10/29/2018	10/29/2018	11	7847	705.50
SCHUTAN	Schutt, Tanner	9/21/18 & 10/5/18	Mileage	10/24/2018	10/24/2018	11	7844	308.47
SEAMANFAMI	Seaman Family Petting Zoo	10/18	Petting Zoo	10/22/2018	10/22/2018	11	7837	25.00
THRIFTYWAY	THRIFTYWAY	9/18 Stmt	Supplies	10/29/2018	10/29/2018	11	7848	49.88
UNIVERSIT4	UNIVERSITY OF NEBRASKA-LINCOLN	11/8/18	Math Day	10/17/2018	10/17/2018	11	7836	202.00
YOUNPAM	Young, Pamela	10/18/18	ILCD Mtg. Meal	10/29/2018	10/29/2018	11	7849	10.28
Batch Total:								112,732.48
Report Total:								112,732.48

Manual Journal Entries Listing - Summary
October 2018 Petty Cash

<u>Chart of Account Number</u>	<u>Entry Date</u>	<u>Reference Number</u>	<u>Transaction Description</u>	<u>Debit Amount</u>	<u>Credit Amount</u>
Batch Description: PETTY CASH JOURNAL		Processing Month: 10/2018			
11 101	10/02/2018		Payflex Claims	0.00	168.38
11 9000 461 000 0000 0 000	10/02/2018		Payflex Claims	168.38	0.00
11 101	10/16/2018		Payflex Claims	0.00	1,179.93
11 9000 461 000 0000 0 000	10/16/2018		Payflex Claims	1,179.93	0.00
11 101	10/23/2018		Payflex Claims	0.00	383.62
11 9000 461 000 0000 0 000	10/23/2018		Payflex Claims	383.62	0.00
11 101	10/11/2018		Payflex Claims	0.00	450.18
11 9000 461 000 0000 0 000	10/11/2018		Payflex Claims	450.18	0.00
Total:				<u>2,182.11</u>	<u>2,182.11</u>

Fund Totals:

<u>Fund</u>	<u>Debit Amount</u>	<u>Credit Amount</u>
11 PETTY CASH	2,182.11	2,182.11
Grand Totals:	<u>2,182.11</u>	<u>2,182.11</u>

Fund: 01 GENERAL FUND

<u>Account Number</u>	<u>Description</u>	<u>Revised Budget</u>	<u>During Month</u>	<u>To Date</u>	<u>% of Budget</u>	<u>Budget Balance</u>
01 1100	Taxes Levied	0.00	221,799.85	1,870,114.80	0.00	(1,870,114.80)
01 1115	Carlisle	0.00	0.00	476.07	0.00	(476.07)
01 1120	PUB POWER DIST SALES TAX	0.00	0.00	0.00	0.00	0.00
01 1125	MOTOR VEHICLES FEES	0.00	24,672.54	68,607.01	0.00	(68,607.01)
01 1311	TUIT INDIV GEN ED	0.00	0.00	0.00	0.00	0.00
01 1312	SUMMER SCHOOL TUITION & FEES	0.00	0.00	0.00	0.00	0.00
01 1321	PATHWAYS TUITION	0.00	0.00	1,000.00	0.00	(1,000.00)
01 1323	TUIT FROM OTHER DIST	0.00	0.00	0.00	0.00	0.00
01 1335	Preschool SpEd Tuition	0.00	0.00	0.00	0.00	0.00
01 1423	TRANS FROM OTHER DIST-SP ED	0.00	0.00	0.00	0.00	0.00
01 1510	INT EARNED LOC REV RECPT	0.00	3,688.82	6,059.78	0.00	(6,059.78)
01 1790	OTHER LOC RECPTS	0.00	0.00	0.00	0.00	0.00
01 1800	Community Service - CKC	0.00	2,761.63	6,305.98	0.00	(6,305.98)
01 1910	Rental of Property & Facilities	0.00	0.00	0.00	0.00	0.00
01 1911	LOC LICENSE FEES	0.00	0.00	75.00	0.00	(75.00)
01 1920	CONTRIBUTIONS & DONATIONS	0.00	1,642.50	1,642.50	0.00	(1,642.50)
01 1921	POLICE COURT FINES	0.00	0.00	0.00	0.00	0.00
01 1925	Categorical Grants	0.00	0.00	79.79	0.00	(79.79)
01 1951	Misc. Revenue from Other Schools	0.00	0.00	0.00	0.00	0.00
01 1960	Misc Revenue from other local govt. unit	0.00	0.00	15,010.00	0.00	(15,010.00)
01 1990	Misc. Local Receipts	0.00	589.50	22,589.50	0.00	(22,589.50)
	Subtotal: 1000	0.00	255,154.84	1,991,960.43	0.00	(1,991,960.43)
01 2110	CO FINES AND LICENSE	0.00	1,323.82	2,636.49	0.00	(2,636.49)
01 2130	OTHER COUNTY SOURCES	0.00	0.00	0.00	0.00	0.00
01 2210	ED SERVICE UNIT RECEIPTS	0.00	0.00	0.00	0.00	0.00
	Subtotal: 2000	0.00	1,323.82	2,636.49	0.00	(2,636.49)
01 3110	STATE AID	0.00	32,184.00	64,368.00	0.00	(64,368.00)
01 3120	SPED	0.00	0.00	0.00	0.00	0.00
01 3125	SPED TRANSPORTATION	0.00	0.00	0.00	0.00	0.00
01 3130	HOMESTEAD EXEMPTION	0.00	0.00	0.00	0.00	0.00
01 3131	RELIEF TO PROPERTY TAXPAYERS	0.00	0.00	0.00	0.00	0.00
01 3132	Personal Property Tax Credit	0.00	0.00	0.00	0.00	0.00
01 3133	NAMEPLATE CAPACITY (WIND ENERGY)	0.00	14,423.92	14,423.92	0.00	(14,423.92)
01 3155	TEXTBOOK RULE 4	0.00	0.00	0.00	0.00	0.00
01 3180	PRO-RATE MOTOR VEHICLE	0.00	1,806.41	1,806.41	0.00	(1,806.41)
01 3400	STATE APPORTIONMENT	0.00	0.00	0.00	0.00	0.00
01 3535	HIGH ABILITY LEARNERS	0.00	5,046.00	5,046.00	0.00	(5,046.00)
01 3575	After School Innovation Grant	0.00	0.00	0.00	0.00	0.00
	Subtotal: 3000	0.00	53,460.33	85,644.33	0.00	(85,644.33)
01 4105	Universal Service Fund (E-RATE)	0.00	0.00	0.00	0.00	0.00
01 4310	REAP	0.00	0.00	0.00	0.00	0.00
01 4505	Title I	0.00	0.00	15,755.04	0.00	(15,755.04)
01 4506	Title I Accountability	0.00	0.00	0.00	0.00	0.00
01 4509	Title IIA Grant	0.00	0.00	0.00	0.00	0.00
01 4512	Idea Base Allocation SPED Preschool	0.00	0.00	0.00	0.00	0.00
01 4516	IDEA Preschool Base	0.00	0.00	0.00	0.00	0.00
01 4519	E/P IDEA Grant	0.00	0.00	0.00	0.00	0.00
01 4521	IDEA Proportionate Share	0.00	0.00	0.00	0.00	0.00
01 4525	FED Vocational EDUC (Perkins)	0.00	0.00	0.00	0.00	0.00
01 4526	Migrant Ed	0.00	0.00	447.97	0.00	(447.97)
01 4530	Federal Grants	0.00	0.00	0.00	0.00	0.00
01 4700	Grants-In-Aid Fed Govt	0.00	0.00	21,000.00	0.00	(21,000.00)
01 4708	Medicaid Reimb	0.00	0.00	0.00	0.00	0.00

Fund: 01 GENERAL FUND

<u>Account Number</u>	<u>Description</u>	<u>Revised Budget</u>	<u>During Month</u>	<u>To Date</u>	<u>% of Budget</u>	<u>Budget Balance</u>
01 4709	Medicaid Administrative Activities (MAC)	0.00	0.00	0.00	0.00	0.00
01 4900	Grant/Loans	0.00	0.00	0.00	0.00	0.00
	Subtotal: 4000	0.00	0.00	37,203.01	0.00	(37,203.01)
01 5200	Trans From Other Funds	0.00	0.00	0.00	0.00	0.00
01 5300	Sale of Property	0.00	50.00	50.00	0.00	(50.00)
01 5301	INS Adjust	0.00	0.00	0.00	0.00	0.00
01 5690	Other Non-Revenue Receipts	0.00	35.00	126.60	0.00	(126.60)
	Subtotal: 5000	0.00	85.00	176.60	0.00	(176.60)
01 9000	Non Program Recpts	0.00	0.00	0.00	0.00	0.00
	Subtotal: Non-Program Receipts	0.00	0.00	0.00	0.00	0.00
	Fund Total:	0.00	310,023.99	2,117,620.86	0.00	(2,117,620.86)

Revenue Summary Report

Processing Month: 10/2018

October 2018

	<u>Revised Budget</u>	<u>During Month</u>	<u>To Date</u>	<u>% of Budget</u>	<u>Budget Balance</u>
Grand Total:	0.00	310,023.99	2,117,620.86	0.00	(2,117,620.86)

ELECTRICITY

	KWH USED		KWH USED		KWH USED		KWH USED		KWH USED		KWH USED	
	2013-2014		2014-2015		2015-2016		2016-2017		2017-2018		2018=2019	
September	\$10,126.61	113304	\$8,600.65	94040	\$9,141.83	102760	\$6,797.40	79200	\$9,869.30	113280	\$14,856.67	193717
	\$1,844.40	21200	\$1,221.12	16960	\$1,415.68	17920	\$1,038.16	15520	\$928.00	11600	\$1,587.20	19840
	\$105.80	1120	\$96.63	985	\$88.22	870	\$84.30	816	\$72.52	655	\$112.37	1221
					2288.99	28206	\$1,408.22	19081	\$191.32	1215	\$105.57	184
October	\$5,501.76	73117	\$7,300.07	74280	\$7656.22	79560	\$6,649.99	68800	\$11,426.12	111800	\$10,979.43	73052
	\$912.80	13040	\$984.96	13680	\$1,181.84	14960	\$914.00	13600	\$1,107.20	13840	\$998.40	12480
	\$41.48	341	\$73.01	671	\$63.15	526	\$69.58	614	\$66.75	575	\$68.65	609
					\$327.99	3303	\$310.35	2641	\$3,161.33	37867	\$83.10	112
November	\$5,663.40	82158	\$5,464.30	75320	\$6296.47	79600	\$5860.31	72840	\$7,597.89	97240		
	\$1,148.00	16400	\$1,140.48	15840	\$1,170.00	15600	\$1,047.84	14160	\$1,047.84	14160		
	\$52.65	531	\$68.66	749	\$68.81	682	\$71.90	730	\$66.88	651		
					\$318.42	3575	\$523.19	6078	\$1,253.82	15949		
December	\$4,791.14	70974	\$4,272.47	57640	\$4345.58	55600	\$4923.83	64720	\$7,151.59	82080		
	\$1,092.00	15600	\$933.12	12960	\$870.00	11600	\$852.48	11520	\$905.76	12240		
	\$58.20	626	\$59.13	594	\$57.42	504	\$65.14	624	\$63.60	601		
					102.18	296	\$161.03	564	\$58.91	97		
January	\$3,835.05	47880	\$4,800.45	63600	\$4608.55	58720	\$5436.31	72080	\$7,960.65	110840		
	\$812.16	11280	\$1,032.00	13760	\$876.16	11840	\$870.24	11760	\$899.84	12160		
	\$70.51	779	\$73.29	784	\$68.62	679	\$69.87	698	\$69.49	692		
					\$84.95	557	\$101.23	535	\$64.28	163		
February	\$4,606.71	66760	\$5,353.88	74960	\$5,159.28	69840	\$5860.95	81320	\$9,598.25	160160		
	\$1,209.60	16800	\$1,260.00	16800	\$1,101.12	14880	\$1,065.60	14400	\$1,385.28	17760		
	\$79.11	919	\$64.78	645	\$75.28	782	\$73.15	749	\$81.74	869		
					\$68.90	373	\$95.22	466	\$68.42	211		
March	\$4,242.59	58480	\$4,583.08	58480	\$4568.54	57960	\$5111.31	68400	\$7,615.46	106160		
	\$996.48	13840	\$1,026.00	13680	\$882.08	11920	\$846.56	11440	\$929.76	11920		
	\$65.05	690	\$66.26	670	\$57.81	511	\$61.09	561	\$62.04	568		
					\$61.23	285	\$85.00	349	\$61.40	126		
April	\$4,496.22	63440	\$4,350.50	54320	\$4,810.92	62680	\$5,290.99	70600	\$7,269.83	110800		
	\$1,013.76	14080	\$894.00	11920	\$947.20	12800	\$947.20	12800	\$1,048.32	13440		
	\$64.40	680	\$58.49	544	\$63.02	591	\$60.90	559	\$68.22	662		
					\$53.92	201	\$84.09	338	\$40.91	120		
May	\$4,640.94	64120	\$4,771.97	62200	\$5508.57	63040	\$4978.73	66920	\$6,707.98	85000		
	\$967.68	13440	\$1,008.00	13440	\$876.16	11840	\$888.00	12000	\$1,010.88	12960		
	\$41.09	302	\$57.84	533	\$54.92	465	\$53.37	441	\$56.75	487		
					\$56.88	235	\$81.77	312	\$56.21	63		
June	\$4,946.17	59600	\$5,127.07	54880	\$5185.79	60520	\$5240.85	53440	\$9,520.98	139440		
	\$581.76	8080	\$594.00	7920	\$657.12	8880	\$497.28	6720	\$1,023.36	13120		
	\$34.99	203	\$53.27	440	\$47.58	352	\$47.00	343	\$54.20	448		
					\$100.27	736	\$130.55	882	\$54.80	46		
July	\$7,663.07	85036	\$6,661.68	74680	\$5803.93	65960	\$2993.71	29640	\$10,368.19	130200		
	\$570.24	7920	\$619.36	7840	\$572.56	8320	\$531.20	6640	\$544.00	6800		
	\$41.71	256	\$60.86	494	\$53.45	392	\$78.19	732	\$44.46	272		
					\$153.95	1013	\$211.60	1420	\$66.31	21		
August	\$6,947.35	80520	\$7,770.95	87520	\$6408.13	81560	\$3731.83	42960	\$10,645.58	147160		
	\$541.44	7520	\$739.44	9360	\$613.98	8960	\$608.00	7600	\$748.80	9360		
	\$68.27	608	\$91.05	909	91.6	917	\$91.60	917	\$99.39	1039		
					\$199.49	1464	230.01	1616	\$78.22	242		
TOTAL	\$79,874.59	1,031,644	\$81,332.82	994,098	\$85,065.27	1,033,371	\$77,231.12	951,146	\$123,272.83	1,607,159		

NATURAL GAS

	2013-2014	2014-2015	2015-2016	2016-2017	2017-2018	2018-2019						
September	\$629.71	554	\$1,130.44	1268	\$677.34	677	759.63	676	854.52	859	\$537.72	528
	\$200.42	136	\$234.58	183	\$206.81	138	\$245.03	144	\$247.13	113	\$352.66	275
	\$36.20	10	\$56.60	27	\$37.74	10	\$44.11	12	\$61.22	24	\$79.95	46
							\$45.28	7	60.24	0	\$59.22	0
October	\$2,460.80	2816	\$2,050.30	2418	\$1,519.67	1920	\$1,541.40	1637	1588.87	1765	2094.58	2527
	\$1,135.39	1294	\$657.32	735	\$513.83	573	\$512.87	497	\$866.63	878	\$965.81	1122
	\$168.43	161	\$118.19	96	\$108.30	95	\$108.93	85	\$210.28	201	\$169.97	170
							\$62.75	23	\$72.86	11	\$60.29	1
November	\$3,402.24	3979	\$3,893.43	4728	\$3,017.77	3959	2582.11	3049	3237.31	3788		
	\$2,097.81	2486	\$2,229.91	2783	\$1,498.56	1968	\$1,305.61	1548	\$1,740.26	1953		
	\$252.63	265	\$318.70	337	\$253.03	298	\$256.44	280	\$326.92	344		
							\$174.65	77	\$113.46	49		
December	\$5,416.23	6467	\$5,662.71	7005	\$4,909.37	6615	8781.03	11105	\$5,687.32	6776		
	\$3,563.23	4301	\$2,927.17	3697	\$2,381.62	3219	\$3,051.25	3815	\$2,764.40	3204		
	\$544.02	625	\$432.66	475	\$308.64	376	\$518.61	619	\$518.90	578		
							\$291.04	255	\$173.98	123		
January	\$4,863.77	5785	\$4,493.27	5495	\$4,518.45	6187	6055.87	7381	6275.86	7550		
	\$3,437.08	4145	\$2,281.91	2851	\$2,326.50	3136	\$2,355.09	2839	\$2,794.61	3264		
	\$615.88	714	\$301.23	316	\$334.04	411	\$435.35	499	\$509.85	571		
					\$210.69	206	\$237.47	192	\$173.06	123		
February	\$4,999.77	5953	\$4,486.24	5476	\$2,843.25	3722	4278.96	5176	\$5,670.93	6863		
	\$3,106.85	3736	\$2,453.79	3073	\$1,644.07	2136	\$1,929.13	2320	\$2,729.66	3209		
	\$543.02	624	\$381.76	413	\$264.67	309	\$358.30	406	\$482.64	542		
					\$137.26	113	\$190.91	132	\$168.65	118		
March	\$3,134.67	3649	\$2,285.50	2668	\$2,537.61	3297	3015.03	3599	4136.68	4960		
	\$1,860.23	2192	\$1,204.93	1436	\$1,337.01	1701	\$1,381.24	1636	\$1,931.63	2216		
	\$351.17	387	\$178.55	167	\$235.44	268	\$287.47	320	\$366.52	398		
					\$114.23	83	\$154.67	91	\$129.22	69		
April	\$2,079.09	2345	\$1,722.39	1952	\$1,449.44	1728	2292.53	2611	\$2,245.70	2627		
	\$1,021.34	1153	\$750.24	840	\$721.46	829	\$879.74	957	\$1,265.08	1396		
	\$160.94	152	\$102.56	75	\$140.60	135	\$182.90	179	\$232.42	233		
					\$62.93	27	\$102.42	40	\$99.37	35		
May	\$1,182.67	1228	\$939.84	1090	\$897.23	908	1200.9	1083	475.11	441		
	\$432.83	423	\$352.58	353	\$299.51	238	\$334.88	219	\$303.50	202		
	\$74.55	42	\$84.45	63	\$65.76	34	\$83.21	44	\$73.92	38		
					\$65.76	13	\$67.18	6	\$60.54	0		
June	\$722.09	704	\$354.57	485	\$405.55	208	363.66	96	\$91.96	91		
	\$145.96	75	\$91.20	74	\$176.23	65	\$189.66	53	\$68.15	\$65.00		
	\$34.99	9	\$37.74	10	\$40.28	9	\$45.22	10	\$21.96	9		
					\$43.82	6	\$59.36	0	\$25.17	0		
July	\$539.98	492	\$556.66	505	\$369.02	106	265.44	7	221.91	97		
	\$145.96	75	\$168.69	84	\$193.06	79	\$189.66	53	\$186.19	58		
	\$36.15	10	\$39.83	12	\$39.49	8	\$45.22	10	\$43.50	10		
							59.36	0	59.01	0		
August	\$502.13	417	\$625.62	602	\$592.36	424	414.28	318	266.01	155		
	\$176.31	112	\$193.40	119	\$216.76	107	\$204.33	66	\$221.95	95		
	\$36.22	10	\$35.64	8	\$41.90	10	\$45.11	11	\$42.65	9		
					\$43.08	5	61.12	0	59.22	0		
TOTAL	\$50,110.76	57526	\$43,834.60	51919	\$37,757.06	46351	\$47,985.29	54183	\$49,897.71	56110		
					*added Redler house 11/15							
					**added Beckman house 12/15							

BOARD EXPENDITURE REPORT BY FUNCTION

October 2018

Account Number	Account Description	Revised Budget	Expended During Month	Expenditures to Date	% of Budget	Balance at EOM	A/ P Outstanding	P/ O Outstanding
1100	REGULAR INSTRUCTIONAL PROGRAMS							
01 1100 111 000 0000 0 000	Salaries-Teachers/Prof District	0.00	5,075.00	10,150.00	0.00	(10,150.00)	0.00	0.00
01 1100 111 002 0000 1 000	Salaries-Teachers/Prof Elementary	0.00	67,505.57	135,617.91	0.00	(135,617.91)	0.00	0.00
01 1100 111 001 0000 2 000	Salaries-Teacher/Prof Secondary	0.00	78,931.32	154,862.64	0.00	(154,862.64)	0.00	0.00
01 1100 111 001 1116 2 000	Pathways Salaries-Teachers/Prof HS	0.00	7,192.00	14,384.00	0.00	(14,384.00)	0.00	0.00
01 1100 111 004 0000 3 000	Salaries-Teachers/Prof Middle School	0.00	43,757.38	87,390.96	0.00	(87,390.96)	0.00	0.00
01 1100 112 002 0000 1 000	TCHR AIDE SAL EL	0.00	13,317.39	25,374.25	0.00	(25,374.25)	0.00	0.00
01 1100 112 001 0000 2 000	SALARY-CLERICAL/PARAPROF STAFF	0.00	715.25	752.14	0.00	(752.14)	0.00	0.00
01 1100 112 004 0000 3 000	MS Para	0.00	462.82	819.48	0.00	(819.48)	0.00	0.00
01 1100 113 000 0000 0 000	SUB SALARY INLIEU OF	0.00	360.00	405.00	0.00	(405.00)	0.00	0.00
01 1100 122 002 0000 1 000	Salaries - Elem Para Sub	0.00	1,246.25	1,491.27	0.00	(1,491.27)	0.00	0.00
01 1100 122 001 0000 2 000	Salaries - HSPara Sub	0.00	0.00	0.00	0.00	0.00	0.00	0.00
01 1100 122 004 0000 3 000	Salaries - MS Para Sub	0.00	10.00	10.00	0.00	(10.00)	0.00	0.00
01 1100 123 002 0000 1 000	SUB SAL EL	0.00	1,667.50	2,587.50	0.00	(2,587.50)	0.00	0.00
01 1100 123 001 0000 2 000	SUB SAL SEC	0.00	2,242.50	2,415.00	0.00	(2,415.00)	0.00	0.00
01 1100 123 001 1116 2 000	Salaries-Substitute Teachers Pathways	0.00	0.00	57.50	0.00	(57.50)	0.00	0.00
01 1100 123 004 0000 3 000	MS Substitutes	0.00	690.00	977.50	0.00	(977.50)	0.00	0.00
01 1100 150 000 2195 0 000	Activity Extra Duty	0.00	60.00	577.50	0.00	(577.50)	0.00	0.00
01 1100 150 001 2190 2 000	Athletic Coaches High School	0.00	3,732.30	7,464.60	0.00	(7,464.60)	0.00	0.00
01 1100 150 001 2190 2 300	Extra Duty Non-Inst- HS events	0.00	285.00	365.00	0.00	(365.00)	0.00	0.00
01 1100 150 004 2190 3 000	Athletic Coaches Middle School	0.00	0.00	0.00	0.00	0.00	0.00	0.00
01 1100 150 004 2190 3 300	Extra Duty Non-Inst- MS events	0.00	0.00	0.00	0.00	0.00	0.00	0.00
01 1100 151 000 2195 0 000	Activities Sponsors HighSchool	0.00	1,069.60	1,139.20	0.00	(1,139.20)	0.00	0.00
01 1100 151 001 2190 2 000	Athletic Coaches HS	0.00	7,374.70	14,749.40	0.00	(14,749.40)	0.00	0.00
01 1100 151 001 2195 2 000	Activity Sponsors Teachers/Prof Staff HS	0.00	3,800.45	7,600.90	0.00	(7,600.90)	0.00	0.00
01 1100 151 001 2190 2 300	Extra Duty Teachers - HS events	0.00	2,060.00	2,760.00	0.00	(2,760.00)	0.00	0.00
01 1100 151 004 2190 3 000	Athletic Coaches Teachers/Prof Staff MS	0.00	2,436.00	4,872.00	0.00	(4,872.00)	0.00	0.00
01 1100 151 004 2195 3 000	Activity Sponsors Teachers/Prof Staff MS	0.00	162.40	324.80	0.00	(324.80)	0.00	0.00
01 1100 151 004 2190 3 300	Extra Duty Teachers - MS events	0.00	940.00	940.00	0.00	(940.00)	0.00	0.00
01 1100 211 000 0000 0 000	HEALTH INSURANCE	0.00	1,229.87	2,459.74	0.00	(2,459.74)	0.00	0.00
01 1100 211 002 0000 1 000	BCBS	0.00	19,877.34	39,745.38	0.00	(39,745.38)	0.00	0.00
01 1100 211 001 0000 2 000	BCBS	0.00	20,932.91	41,865.82	0.00	(41,865.82)	0.00	0.00
01 1100 211 001 1116 2 000	Pathways Health Ins	0.00	2,108.34	4,216.68	0.00	(4,216.68)	0.00	0.00
01 1100 211 004 0000 3 000	MS Health Insurance	0.00	11,653.88	23,255.21	0.00	(23,255.21)	0.00	0.00
01 1100 212 002 0000 1 000	Group Insurance-Elem Para	0.00	1,553.97	3,074.45	0.00	(3,074.45)	0.00	0.00
01 1100 212 001 0000 2 000	Group Insurance - Para HS	0.00	2.99	2.99	0.00	(2.99)	0.00	0.00
01 1100 212 004 0000 3 000	Group Insurance - MS Para	0.00	106.25	156.45	0.00	(156.45)	0.00	0.00
01 1100 220 000 2195 0 000	Social Security - Activity Sponsor Non-I	0.00	4.59	44.18	0.00	(44.18)	0.00	0.00
01 1100 220 001 2190 2 000	HS Social Security - Non-Inst.Extra Duty	0.00	285.51	571.02	0.00	(571.02)	0.00	0.00
01 1100 220 001 2190 2 300	HS Social Security - NonInst Extra duty	0.00	21.81	27.93	0.00	(27.93)	0.00	0.00
01 1100 221 000 0000 0 000	SOC SEC	0.00	384.75	781.73	0.00	(781.73)	0.00	0.00
01 1100 221 000 2195 0 000	Social Security - Activity Sponsor	0.00	81.83	87.16	0.00	(87.16)	0.00	0.00
01 1100 221 002 0000 1 000	SOC SEC EL	0.00	5,031.62	10,117.21	0.00	(10,117.21)	0.00	0.00
01 1100 221 001 0000 2 000	SOC SEC SEC	0.00	5,978.02	11,797.46	0.00	(11,797.46)	0.00	0.00
01 1100 221 001 1116 2 000	HS Social Security - Teachers Pathways	0.00	548.21	1,103.41	0.00	(1,103.41)	0.00	0.00
01 1100 221 001 2190 2 000	HS Social Security - Teacher Coaches	0.00	564.18	1,128.35	0.00	(1,128.35)	0.00	0.00

BOARD EXPENDITURE REPORT BY FUNCTION

October 2018

Account Number	Account Description	Revised Budget	Expended During Month	Expenditures to Date	% of Budget	Balance at EOM	A/ P Outstanding	P/ O Outstanding
01 1100 221 001 2195 2 000	HS Social Security - Activity Sponsors	0.00	290.71	581.41	0.00	(581.41)	0.00	0.00
01 1100 221 001 2190 2 300	HS Social Security -Teachers Extra Duty	0.00	157.59	211.16	0.00	(211.16)	0.00	0.00
01 1100 221 004 0000 3 000	MS Social Security	0.00	3,329.01	6,679.36	0.00	(6,679.36)	0.00	0.00
01 1100 221 004 2190 3 000	MS Social Security - Teachers Coaches	0.00	186.37	372.73	0.00	(372.73)	0.00	0.00
01 1100 221 004 2195 3 000	MS Social Security - Activity Sponsors	0.00	12.43	24.87	0.00	(24.87)	0.00	0.00
01 1100 221 004 2190 3 300	MS Social Security - Extra Duty	0.00	71.91	71.91	0.00	(71.91)	0.00	0.00
01 1100 222 002 0000 1 000	Social Security	0.00	1,089.12	2,005.81	0.00	(2,005.81)	0.00	0.00
01 1100 222 001 0000 2 000	Social Security	0.00	54.72	57.54	0.00	(57.54)	0.00	0.00
01 1100 222 004 0000 3 000	Social Security	0.00	35.46	62.03	0.00	(62.03)	0.00	0.00
01 1100 223 000 0000 0 000	Social Security	0.00	27.60	31.06	0.00	(31.06)	0.00	0.00
01 1100 223 002 0000 1 000	Social Security	0.00	127.59	197.97	0.00	(197.97)	0.00	0.00
01 1100 223 001 0000 2 000	Social Security	0.00	171.60	184.80	0.00	(184.80)	0.00	0.00
01 1100 223 001 1116 2 004	Social Security	0.00	0.00	4.39	0.00	(4.39)	0.00	0.00
01 1100 223 004 0000 3 000	Social Security	0.00	52.77	74.79	0.00	(74.79)	0.00	0.00
01 1100 230 001 2190 2 300	HS Retirement Extra Duty	0.00	11.36	15.32	0.00	(15.32)	0.00	0.00
01 1100 231 000 0000 0 000	RETIRE SUB INLIEU	0.00	501.30	1,002.60	0.00	(1,002.60)	0.00	0.00
01 1100 231 000 2195 0 000	Retirement - Activity Sponsors	0.00	105.65	112.52	0.00	(112.52)	0.00	0.00
01 1100 231 002 0000 1 000	RETIREMENT	0.00	7,129.16	13,363.73	0.00	(13,363.73)	0.00	0.00
01 1100 231 001 0000 2 000	RETIREMENT	0.00	7,796.66	15,296.98	0.00	(15,296.98)	0.00	0.00
01 1100 231 001 1116 2 000	HS Retirement - Teachers Pathways	0.00	710.42	1,420.84	0.00	(1,420.84)	0.00	0.00
01 1100 231 001 2190 2 000	HS Retirement - Coach	0.00	688.34	1,376.68	0.00	(1,376.68)	0.00	0.00
01 1100 231 001 2195 2 000	HS Retirement - Activity Sponsors	0.00	367.94	735.89	0.00	(735.89)	0.00	0.00
01 1100 231 001 2190 2 300	HS Retirement - Teacher Coach	0.00	205.59	274.79	0.00	(274.79)	0.00	0.00
01 1100 231 004 0000 3 000	MS Retirement	0.00	4,175.10	8,337.95	0.00	(8,337.95)	0.00	0.00
01 1100 231 004 2190 3 000	MS Retirement - Teacher Coach	0.00	240.61	481.22	0.00	(481.22)	0.00	0.00
01 1100 231 004 2195 3 000	MS Retirement - Activity Sponsors	0.00	16.04	32.08	0.00	(32.08)	0.00	0.00
01 1100 231 004 2190 3 300	MS Retirement - Teacher Coach	0.00	73.16	73.16	0.00	(73.16)	0.00	0.00
01 1100 232 002 0000 1 000	Retirement	0.00	1,307.20	2,466.36	0.00	(2,466.36)	0.00	0.00
01 1100 232 001 0000 2 000	Retirement	0.00	70.66	74.30	0.00	(74.30)	0.00	0.00
01 1100 232 004 0000 3 000	Retirement	0.00	46.70	81.93	0.00	(81.93)	0.00	0.00
01 1100 233 000 0000 0 000	Retirement Sub In Lieu	0.00	35.51	39.95	0.00	(39.95)	0.00	0.00
01 1100 270 000 0000 0 000	Work Comp - Non-Instructional	0.00	0.00	614.03	0.00	(614.03)	0.00	0.00
01 1100 271 000 0000 0 000	Work Comp-Teachers/Prof	0.00	0.00	1,842.06	0.00	(1,842.06)	0.00	0.00
01 1100 272 000 0000 0 000	Work Comp Instructional Paras	0.00	0.00	614.03	0.00	(614.03)	0.00	0.00
01 1100 281 000 0000 0 000	Other Health Benefits	0.00	1,052.69	1,375.38	0.00	(1,375.38)	0.00	0.00
01 1100 281 002 0000 1 000	Other Health Benefits	0.00	795.31	1,590.62	0.00	(1,590.62)	0.00	0.00
01 1100 281 001 0000 2 000	Other Health Benefits	0.00	1,071.26	2,142.52	0.00	(2,142.52)	0.00	0.00
01 1100 281 001 1116 2 000	HS Health Benefits - Pathways Teachers	0.00	381.74	763.48	0.00	(763.48)	0.00	0.00
01 1100 281 004 0000 3 000	Other Health Benefits	0.00	652.54	1,305.08	0.00	(1,305.08)	0.00	0.00
01 1100 291 000 0000 0 000	Other Benefits	0.00	0.00	0.00	0.00	0.00	0.00	0.00
01 1100 340 004 0000 3 000	Other Professional Services	0.00	0.00	143.52	0.00	(143.52)	0.00	0.00
01 1100 550 000 0000 0 000	Copiers/Printers Buyout	0.00	0.00	16,475.68	0.00	(16,475.68)	0.00	0.00
01 1100 550 002 0000 1 000	Elem Copier	0.00	1,206.00	3,097.23	0.00	(3,097.23)	0.00	0.00
01 1100 550 001 0000 2 000	Copiers	0.00	1,389.64	3,888.90	0.00	(3,888.90)	0.00	0.00
01 1100 550 004 0000 3 000	MS Copiers	0.00	791.90	1,784.55	0.00	(1,784.55)	0.00	0.00
01 1100 610 000 0000 0 000	Supplies	0.00	50.30	50.30	0.00	(50.30)	0.00	0.00
01 1100 610 000 1126 0 000	Art Supplies	0.00	449.54	1,912.29	0.00	(1,912.29)	0.00	0.00
01 1100 610 002 0000 0 000	Supplies	0.00	508.00	508.00	0.00	(508.00)	0.00	0.00
01 1100 610 002 0000 1 000	Elementary Requisitions	0.00	90.95	5,080.02	0.00	(5,080.02)	0.00	0.00
01 1100 610 002 1101 1 000	Other Expenses Gr. 1	0.00	371.31	371.31	0.00	(371.31)	0.00	0.00

BOARD EXPENDITURE REPORT BY FUNCTION

October 2018

Account Number	Account Description	Revised Budget	Expended During Month	Expenditures to Date	% of Budget	Balance at EOM	A/ P Outstanding	P/ O Outstanding
01 1100 610 002 1103 1 000	THIRD GRADE SUPPLIES	0.00	697.62	745.42	0.00	(745.42)	0.00	0.00
01 1100 610 002 1104 1 000	FOURTH GRADE SUPPLIES	0.00	185.03	185.03	0.00	(185.03)	0.00	0.00
01 1100 610 002 1107 1 000	KINDERGARTEN SUPPLIES	0.00	99.59	99.59	0.00	(99.59)	0.00	0.00
01 1100 610 002 1108 1 000	TITLE I SUPPLIES	0.00	97.62	97.62	0.00	(97.62)	0.00	0.00
01 1100 610 002 1127 1 000	Elem Music Supplies	0.00	109.95	109.95	0.00	(109.95)	0.00	0.00
01 1100 610 002 1128 1 000	Elem Band Supplies	0.00	21.58	216.88	0.00	(216.88)	0.00	0.00
01 1100 610 002 0000 1 100	ELEM FURN/EQUIP	0.00	0.00	370.43	0.00	(370.43)	0.00	0.00
01 1100 610 001 0000 2 000	Supplies	0.00	228.64	910.13	0.00	(910.13)	0.00	0.00
01 1100 610 001 1116 2 000	PATHWAYS FURNITURE & EQUIPMENT	0.00	0.17	0.17	0.00	(0.17)	0.00	0.00
01 1100 610 001 1117 2 000	Lang Arts Supplies	0.00	502.98	502.98	0.00	(502.98)	0.00	0.00
01 1100 610 001 1118 2 000	Spanish Supplies	0.00	87.51	959.51	0.00	(959.51)	0.00	0.00
01 1100 610 001 1119 2 000	Soc Studies Supplies	0.00	263.74	647.76	0.00	(647.76)	0.00	0.00
01 1100 610 001 1120 2 000	Math Supplies	0.00	0.17	737.19	0.00	(737.19)	0.00	0.00
01 1100 610 001 1121 2 000	Business Supplies	0.00	0.00	1,631.00	0.00	(1,631.00)	0.00	0.00
01 1100 610 001 1122 2 000	Science Supplies	0.00	147.25	1,095.87	0.00	(1,095.87)	0.00	0.00
01 1100 610 001 1123 2 000	PE Supplies	0.00	3,689.52	3,689.52	0.00	(3,689.52)	0.00	0.00
01 1100 610 001 1124 2 000	Ind Arts Supplies	0.00	103.14	603.30	0.00	(603.30)	0.00	0.00
01 1100 610 001 1127 2 000	Music Supplies	0.00	262.29	570.71	0.00	(570.71)	0.00	0.00
01 1100 610 001 1128 2 000	Band Supplies	0.00	76.94	771.07	0.00	(771.07)	0.00	0.00
01 1100 610 001 1129 2 000	Ag Supplies	0.00	295.00	295.00	0.00	(295.00)	0.00	0.00
01 1100 610 001 0000 2 100	HS Furniture & Equipment	0.00	254.66	4,839.26	0.00	(4,839.26)	0.00	0.00
01 1100 610 001 1124 2 100	Ind Arts Equipment	0.00	0.00	4,034.09	0.00	(4,034.09)	0.00	0.00
01 1100 610 001 1127 2 100	Music Equipment	0.00	0.00	4,500.00	0.00	(4,500.00)	0.00	0.00
01 1100 610 001 1128 2 100	Band Equipment	0.00	0.00	165.00	0.00	(165.00)	0.00	0.00
01 1100 610 001 1129 2 100	Ag Equipment	0.00	1,973.92	1,973.92	0.00	(1,973.92)	0.00	0.00
01 1100 610 004 0000 3 000	MS Supplies	0.00	43.74	87.56	0.00	(87.56)	0.00	0.00
01 1100 610 004 1117 3 000	MS Lang Arts Supplies	0.00	278.47	318.42	0.00	(318.42)	0.00	0.00
01 1100 610 004 1119 3 000	MS Social Studies Supplies	0.00	37.43	37.43	0.00	(37.43)	0.00	0.00
01 1100 610 004 1123 3 000	MS PE Supplies	0.00	0.00	0.00	0.00	0.00	0.00	0.00
01 1100 610 004 1127 3 000	MS Music Supplies	0.00	123.15	338.35	0.00	(338.35)	0.00	0.00
01 1100 610 004 1128 3 000	MS Band Supplies	0.00	182.60	303.81	0.00	(303.81)	0.00	0.00
01 1100 610 004 0000 3 100	MS Furn/Equip	0.00	0.00	116.29	0.00	(116.29)	0.00	0.00
01 1100 640 002 0000 1 000	TEXTBOOKS EL	0.00	0.00	252.89	0.00	(252.89)	0.00	0.00
01 1100 640 001 0000 2 000	TEXTBOOKS SEC	0.00	0.00	800.00	0.00	(800.00)	0.00	0.00
01 1100 640 004 0000 3 000	MS Textbooks	0.00	0.00	2,547.00	0.00	(2,547.00)	0.00	0.00
01 1100 643 002 0000 1 000	Web-based Software	0.00	0.00	3,578.00	0.00	(3,578.00)	0.00	0.00
01 1100 643 001 1116 2 000	Pathways Web-based Software	0.00	0.00	2,300.00	0.00	(2,300.00)	0.00	0.00
01 1100 643 001 1121 2 000	Web-based Software	0.00	0.00	0.00	0.00	0.00	0.00	0.00
01 1100 643 004 0000 3 000	Web-based Software	0.00	0.00	2,205.00	0.00	(2,205.00)	0.00	0.00
01 1100 650 004 0000 3 000	MS Comp Hardware	0.00	139.91	139.91	0.00	(139.91)	0.00	0.00
01 1100 810 001 1129 1 000	Dues & Fees	0.00	130.00	130.00	0.00	(130.00)	0.00	0.00
01 1100 810 002 0000 1 000	Elem Dues for Memberships	0.00	0.00	129.00	0.00	(129.00)	0.00	0.00
01 1100 810 001 0000 2 000	HS Dues for Membership	0.00	0.00	129.00	0.00	(129.00)	0.00	0.00
01 1100 810 001 1127 2 000	Student Contest Fees	0.00	0.00	80.00	0.00	(80.00)	0.00	0.00
01 1100 810 001 1128 2 000	Band Contest Fees	0.00	0.00	100.00	0.00	(100.00)	0.00	0.00
01 1100 810 004 0000 3 000	MS Dues for Memberships	0.00	0.00	129.00	0.00	(129.00)	0.00	0.00
01 1100 810 004 1127 3 000	MS Student Contest Fees	0.00	0.00	0.00	0.00	0.00	0.00	0.00
1100	REGULAR INSTRUCTIONAL PROGRAMS	0.00	363,391.58	761,301.91	0.00	(761,301.91)	0.00	0.00
1115	Career Academy							
01 1115 111 001 0000 2 000	Salaries-Teachers/Prof Career Acad	0.00	957.00	1,914.00	0.00	(1,914.00)	0.00	0.00
01 1115 211 001 0000 2 000	HS Group Insurance Career Academy	0.00	0.86	1.72	0.00	(1.72)	0.00	0.00
01 1115 221 001 0000 2 000	HS Social Security - Career Acad	0.00	73.21	146.42	0.00	(146.42)	0.00	0.00
01 1115 610 001 1115 2 000	Welding Supplies	0.00	205.52	382.84	0.00	(382.84)	0.00	0.00

BOARD EXPENDITURE REPORT BY FUNCTION

October 2018

Account Number	Account Description	Revised Budget	Expended During Month	Expenditures to Date	% of Budget	Balance at EOM	A/ P Outstanding	P/ O Outstanding
01 1115 640 001 0000 2 000	Career Academy Textbooks	0.00	0.00	1,609.63	0.00	(1,609.63)	0.00	0.00
1115 Career Academy		0.00	1,236.59	4,054.61	0.00	(4,054.61)	0.00	0.00
1190 Early Childhood								
01 1190 111 002 0000 1 000	Salaries-Teachers/Prof Preschool	0.00	8,112.16	16,224.32	0.00	(16,224.32)	0.00	0.00
01 1190 112 002 0000 1 000	Salaries-Preschool Para	0.00	5,778.39	11,151.54	0.00	(11,151.54)	0.00	0.00
01 1190 122 002 0000 1 000	Salaries - Substitute Preschool Para	0.00	68.75	68.75	0.00	(68.75)	0.00	0.00
01 1190 123 002 0000 1 000	Preschool Sub	0.00	345.00	460.00	0.00	(460.00)	0.00	0.00
01 1190 211 002 0000 1 000	PS Group Insurance Teachers/Prof Staff	0.00	3,320.12	6,640.24	0.00	(6,640.24)	0.00	0.00
01 1190 212 002 0000 1 000	PS Group Insurance - Instructional Aides	0.00	309.09	618.03	0.00	(618.03)	0.00	0.00
01 1190 221 002 0000 1 000	PS Social Security - Teachers/Prof	0.00	616.59	1,247.16	0.00	(1,247.16)	0.00	0.00
01 1190 222 002 0000 1 000	PS Social Security - Para	0.00	443.77	851.28	0.00	(851.28)	0.00	0.00
01 1190 223 002 0000 1 000	PS Social Security - Substitute Teachers	0.00	26.38	35.18	0.00	(35.18)	0.00	0.00
01 1190 231 002 0000 1 000	PS Retirement - Teaches/Prof	0.00	801.30	1,602.61	0.00	(1,602.61)	0.00	0.00
01 1190 232 002 0000 1 000	PS Retirement Instructional Aides	0.00	573.86	1,090.29	0.00	(1,090.29)	0.00	0.00
01 1190 330 002 0000 1 000	Preschool Employee Training & Dev.	0.00	0.00	40.00	0.00	(40.00)	0.00	0.00
01 1190 610 002 0000 1 000	Preschool Supplies	0.00	321.47	1,065.62	0.00	(1,065.62)	0.00	0.00
01 1190 610 002 1190 1 000	Supplies	0.00	0.00	0.00	0.00	0.00	0.00	0.00
01 1190 610 002 0000 1 700	PRESCHOOL SUPPLIES	0.00	1,045.00	1,597.80	0.00	(1,597.80)	0.00	0.00
01 1190 643 002 0000 1 000	Web-based Software	0.00	870.20	870.20	0.00	(870.20)	0.00	0.00
1190 Early Childhood		0.00	22,632.08	43,563.02	0.00	(43,563.02)	0.00	0.00
1200 SpEd Instructional Program School Age								
01 1200 111 000 0000 0 000	SpEd Director	0.00	3,774.52	7,549.04	0.00	(7,549.04)	0.00	0.00
01 1200 111 002 0000 1 000	SpEd Salaries-Teacher/Prof Elementary	0.00	9,019.00	18,038.00	0.00	(18,038.00)	0.00	0.00
01 1200 111 001 0000 2 000	SpEd Salaries-Teachers/Prof HS	0.00	9,715.00	19,430.00	0.00	(19,430.00)	0.00	0.00
01 1200 111 004 0000 3 000	SpEd Salaries-Teachers/Prof MS	0.00	4,118.00	8,236.00	0.00	(8,236.00)	0.00	0.00
01 1200 112 002 0000 1 000	AIDES SALARY ELE	0.00	4,513.43	8,275.10	0.00	(8,275.10)	0.00	0.00
01 1200 112 001 0000 2 000	AIDE SALARY SECON	0.00	5,893.73	10,770.85	0.00	(10,770.85)	0.00	0.00
01 1200 112 004 0000 3 000	MS SpEd Para	0.00	4,165.39	7,375.26	0.00	(7,375.26)	0.00	0.00
01 1200 122 002 0000 1 000	Salaries - Elem Para Sub SpEd	0.00	0.00	82.48	0.00	(82.48)	0.00	0.00
01 1200 122 004 0000 3 000	Salaries - MS Para Sub SpEd	0.00	90.00	90.00	0.00	(90.00)	0.00	0.00
01 1200 123 002 0000 1 000	SUB SALARIES ELE	0.00	747.50	805.00	0.00	(805.00)	0.00	0.00
01 1200 123 001 0000 2 000	SUB SALARIES SEC	0.00	345.00	345.00	0.00	(345.00)	0.00	0.00
01 1200 123 004 0000 3 000	MS Sped Substitute	0.00	747.50	747.50	0.00	(747.50)	0.00	0.00
01 1200 211 000 0000 0 000	Group Insurance Teachers SpEd	0.00	746.62	1,493.24	0.00	(1,493.24)	0.00	0.00
01 1200 211 002 0000 1 000	Elem Group Insurance - SpEd	0.00	3,065.62	6,131.24	0.00	(6,131.24)	0.00	0.00
01 1200 211 001 0000 2 000	HS Group Insurance - SpEd	0.00	1,838.95	3,677.90	0.00	(3,677.90)	0.00	0.00
01 1200 211 004 0000 3 000	MS SpEd Health Insurance	0.00	1,108.72	1,803.23	0.00	(1,803.23)	0.00	0.00
01 1200 212 002 0000 1 000	Group Insurance	0.00	20.47	40.96	0.00	(40.96)	0.00	0.00
01 1200 212 001 0000 2 000	Group Insurance	0.00	593.50	1,187.00	0.00	(1,187.00)	0.00	0.00
01 1200 212 004 0000 3 000	Group Insurance	0.00	956.25	1,407.96	0.00	(1,407.96)	0.00	0.00
01 1200 221 000 0000 0 000	District Social Security - Teachers/Prof	0.00	287.31	583.01	0.00	(583.01)	0.00	0.00
01 1200 221 002 0000 1 000	SOC SEC	0.00	685.96	1,371.92	0.00	(1,371.92)	0.00	0.00
01 1200 221 001 0000 2 000	SOC SEC	0.00	739.71	1,491.65	0.00	(1,491.65)	0.00	0.00
01 1200 221 004 0000 3 000	MS Sped Soc Sec	0.00	314.54	630.83	0.00	(630.83)	0.00	0.00
01 1200 222 002 0000 1 000	Social Security	0.00	345.28	639.37	0.00	(639.37)	0.00	0.00
01 1200 222 001 0000 2 000	Social Security	0.00	419.30	760.81	0.00	(760.81)	0.00	0.00
01 1200 222 004 0000 3 000	Social Security	0.00	319.13	558.28	0.00	(558.28)	0.00	0.00
01 1200 223 002 0000 1 000	Social Security	0.00	57.19	61.59	0.00	(61.59)	0.00	0.00

11/09/2018 03:20 PM

October 2018

User ID: GLS

Account Number	Account Description	Revised Budget	Expended During Month	Expenditures to Date	% of Budget	Balance at EOM	A/ P Outstanding	P/ O Outstanding
01 1200 223 001 0000 2 000	Social Security	0.00	26.38	26.38	0.00	(26.38)	0.00	0.00
01 1200 223 004 0000 3 000	Social Security	0.00	57.19	57.19	0.00	(57.19)	0.00	0.00
01 1200 231 000 0000 0 000	Retirement - Teaches/Prof SpEd	0.00	372.84	745.68	0.00	(745.68)	0.00	0.00
01 1200 231 002 0000 1 000	RETIREMENT	0.00	890.87	1,781.74	0.00	(1,781.74)	0.00	0.00
01 1200 231 001 0000 2 000	RETIREMENT	0.00	959.63	1,919.26	0.00	(1,919.26)	0.00	0.00
01 1200 231 004 0000 3 000	MS SpEd Retirement	0.00	406.76	813.53	0.00	(813.53)	0.00	0.00
01 1200 232 002 0000 1 000	Retirement	0.00	445.83	817.87	0.00	(817.87)	0.00	0.00
01 1200 232 001 0000 2 000	Retirement	0.00	582.18	1,063.91	0.00	(1,063.91)	0.00	0.00
01 1200 232 004 0000 3 000	Retirement	0.00	420.32	737.38	0.00	(737.38)	0.00	0.00
01 1200 281 002 0000 1 000	Other Health Benefits	0.00	254.50	509.00	0.00	(509.00)	0.00	0.00
01 1200 281 001 0000 2 000	Other Health Benefits	0.00	222.69	445.38	0.00	(445.38)	0.00	0.00
01 1200 281 004 0000 3 000	Other Health Benefits	0.00	122.07	244.14	0.00	(244.14)	0.00	0.00
01 1200 320 002 0000 1 000	OTHER PROF/TECH SERVICES	0.00	2,323.05	2,323.05	0.00	(2,323.05)	0.00	0.00
01 1200 320 004 0000 3 000	Professional Educational Services	0.00	0.00	0.00	0.00	0.00	0.00	0.00
01 1200 330 000 0000 0 000	Employee Training & Development	0.00	0.00	0.00	0.00	0.00	0.00	0.00
01 1200 330 001 0000 2 000	Employee Training & Development	0.00	0.00	0.00	0.00	0.00	0.00	0.00
01 1200 591 002 0000 1 000	Elem. Purchased Services from ESU	0.00	434.54	434.54	0.00	(434.54)	0.00	0.00
01 1200 591 001 0000 2 000	HS. Purchased Services from ESU	0.00	4,496.58	4,496.58	0.00	(4,496.58)	0.00	0.00
01 1200 591 004 0000 3 000	MS Purchased Services from ESU	0.00	299.19	299.19	0.00	(299.19)	0.00	0.00
01 1200 610 002 0000 1 000	SUPPLIES	0.00	0.00	231.41	0.00	(231.41)	0.00	0.00
01 1200 610 002 0000 1 100	FURNITURE & EQUIPMENT	0.00	0.00	0.00	0.00	0.00	0.00	0.00
01 1200 610 001 0000 2 000	SUPPLIES	0.00	80.00	88.41	0.00	(88.41)	0.00	0.00
1200 SpEd Instructional Program School Age		0.00	67,022.24	120,617.86	0.00	(120,617.86)	0.00	0.00
2110 ATTENDANCE AND SOCIAL WORK								
01 2110 643 000 0000 0 000	Web-based Software	0.00	0.00	0.00	0.00	0.00	0.00	0.00
2110 ATTENDANCE AND SOCIAL WORK		0.00	0.00	0.00	0.00	0.00	0.00	0.00
2120 GUIDANCE SERVICES								
01 2120 111 002 0000 1 000	ElemGuidance Salaries-Teachers/Prof Elem	0.00	3,045.00	6,090.00	0.00	(6,090.00)	0.00	0.00
01 2120 111 001 0000 2 000	HS Salaries- Guidance	0.00	6,684.08	13,368.16	0.00	(13,368.16)	0.00	0.00
01 2120 111 004 0000 3 000	MS Guidance Salaries-Teachers/Prof MS	0.00	2,164.13	4,704.42	0.00	(4,704.42)	0.00	0.00
01 2120 211 002 0000 1 000	Elem Group Insurance - Guidance	0.00	609.08	1,218.16	0.00	(1,218.16)	0.00	0.00
01 2120 211 001 0000 2 000	HS Group Insurance - Guidance	0.00	1,405.56	2,811.12	0.00	(2,811.12)	0.00	0.00
01 2120 211 004 0000 3 000	MS Group Insurance - Guidance	0.00	527.08	1,106.71	0.00	(1,106.71)	0.00	0.00
01 2120 221 002 0000 1 000	Elem Social Security - Guidance	0.00	232.94	465.88	0.00	(465.88)	0.00	0.00
01 2120 221 001 0000 2 000	HS Social Security- Guidance	0.00	507.32	1,028.62	0.00	(1,028.62)	0.00	0.00
01 2120 221 004 0000 3 000	MS Social Security - Guidance	0.00	164.85	358.47	0.00	(358.47)	0.00	0.00
01 2120 231 002 0000 1 000	Elem Retirement - Guidance	0.00	300.78	601.56	0.00	(601.56)	0.00	0.00
01 2120 231 001 0000 2 000	HS Retirement - Guidance	0.00	660.23	1,320.47	0.00	(1,320.47)	0.00	0.00
01 2120 231 004 0000 3 000	MS Retirement - Guidance	0.00	213.77	464.69	0.00	(464.69)	0.00	0.00
01 2120 281 001 0000 2 000	HS Health Benefits-Guidance	0.00	254.50	509.00	0.00	(509.00)	0.00	0.00
01 2120 281 004 0000 3 000	MS Health Benefits Guidance	0.00	95.44	190.88	0.00	(190.88)	0.00	0.00
01 2120 330 001 0000 2 000	Employee Training & Development	0.00	0.00	199.99	0.00	(199.99)	0.00	0.00
01 2120 610 002 0000 1 000	SUPPLIES	0.00	0.00	0.00	0.00	0.00	0.00	0.00
01 2120 610 001 0000 2 000	SUPPLIES	0.00	109.69	109.69	0.00	(109.69)	0.00	0.00
01 2120 610 001 0000 2 100	GUIDANCE FURNITURE/EQUIPMENT	0.00	0.00	0.00	0.00	0.00	0.00	0.00
01 2120 610 004 0000 3 000	MS Guidance Supplies	0.00	27.97	27.97	0.00	(27.97)	0.00	0.00
01 2120 650 001 0000 2 000	COMPUTER EQUIPMENT (SOFTWARE)	0.00	0.00	0.00	0.00	0.00	0.00	0.00
2120 GUIDANCE SERVICES		0.00	17,002.42	34,575.79	0.00	(34,575.79)	0.00	0.00
2141 Psych Services SpEd School Age								
01 2141 111 002 0000 1 000	School Psych Salaries Elem	0.00	3,920.80	7,841.60	0.00	(7,841.60)	0.00	0.00
01 2141 111 001 0000 2 000	School Psych Salaries HS	0.00	603.20	1,206.40	0.00	(1,206.40)	0.00	0.00

BOARD EXPENDITURE REPORT BY FUNCTION

October 2018

Account Number	Account Description	Revised Budget	Expended During Month	Expenditures to Date	% of Budget	Balance at EOM	A/ P Outstanding	P/ O Outstanding
01 2171 340 004 0000 3 000	Other Professional Services	0.00	25.00	25.00	0.00	(25.00)	0.00	0.00
2171	Physical Therapy -School Age	0.00	125.00	150.00	0.00	(150.00)	0.00	0.00
2190	Activities							
01 2190 340 002 0000 1 000	Other Professional Services	0.00	0.00	0.00	0.00	0.00	0.00	0.00
01 2190 340 004 0000 3 000	Other Professional Services	0.00	0.00	0.00	0.00	0.00	0.00	0.00
01 2190 580 001 2195 2 000	HS Speech Travel Expense	0.00	0.00	139.98	0.00	(139.98)	0.00	0.00
01 2190 610 001 2195 2 000	HS Speech Supplies	0.00	295.00	295.00	0.00	(295.00)	0.00	0.00
01 2190 610 004 2195 3 000	MS Speech Supplies	0.00	0.00	0.00	0.00	0.00	0.00	0.00
01 2190 810 001 0000 2 000	Dues & Fees	0.00	0.00	0.00	0.00	0.00	0.00	0.00
2190	Activities	0.00	295.00	434.98	0.00	(434.98)	0.00	0.00
2210	Improvement of Instruction							
01 2210 151 002 0000 1 000	Salaries - Mentor or SAT Elementary	0.00	145.00	290.00	0.00	(290.00)	0.00	0.00
01 2210 151 001 0000 2 000	Salaries - Mentor or SAT HS	0.00	145.00	290.00	0.00	(290.00)	0.00	0.00
01 2210 151 004 0000 3 000	Salaries - Mentor or SAT MS	0.00	139.20	278.40	0.00	(278.40)	0.00	0.00
01 2210 221 002 0000 1 000	Elem Social Security - SAT/Mentors	0.00	11.10	22.20	0.00	(22.20)	0.00	0.00
01 2210 221 001 0000 2 000	HS Social Security - SAT/Mentors	0.00	11.09	22.18	0.00	(22.18)	0.00	0.00
01 2210 221 004 0000 3 000	MS Social Security - SAT/Mentors	0.00	10.64	21.28	0.00	(21.28)	0.00	0.00
01 2210 231 002 0000 1 000	Elem Retirement - SAT/Mentor	0.00	14.31	28.62	0.00	(28.62)	0.00	0.00
01 2210 231 001 0000 2 000	HS Retirement - SAT/Mentor	0.00	14.32	28.64	0.00	(28.64)	0.00	0.00
01 2210 231 004 0000 3 000	MS Retirement - SAT/Mentor	0.00	13.75	27.50	0.00	(27.50)	0.00	0.00
2210	Improvement of Instruction	0.00	504.41	1,008.82	0.00	(1,008.82)	0.00	0.00
2211	School Improvement							
01 2211 151 000 0000 0 000	School Improvement Teachers/Prof Staff	0.00	301.60	603.20	0.00	(603.20)	0.00	0.00
01 2211 221 000 0000 0 000	Social Security - School Improvement	0.00	23.07	46.15	0.00	(46.15)	0.00	0.00
01 2211 231 000 0000 0 000	Retirement - School Improvement	0.00	29.79	59.58	0.00	(59.58)	0.00	0.00
01 2211 610 000 0000 0 000	School Improvement Supplies	0.00	0.00	57.70	0.00	(57.70)	0.00	0.00
2211	School Improvement	0.00	354.46	766.63	0.00	(766.63)	0.00	0.00
2214	Professional Development							
01 2214 151 002 0000 1 000	Elem Teachers/Prof Staff Prof Dev	0.00	0.00	963.91	0.00	(963.91)	0.00	0.00
01 2214 151 001 0000 2 000	HS Teachers/Prof Staff Prof Dev	0.00	0.00	368.40	0.00	(368.40)	0.00	0.00
01 2214 151 004 0000 3 000	MS Teachers/Prof Staff Prof Dev	0.00	0.00	407.43	0.00	(407.43)	0.00	0.00
01 2214 221 002 0000 1 000	Elem Social Security - Teachers PD	0.00	0.00	73.74	0.00	(73.74)	0.00	0.00
01 2214 221 001 0000 2 000	HS Social Security - Teachers PD	0.00	0.00	28.25	0.00	(28.25)	0.00	0.00
01 2214 221 004 0000 3 000	MS Social Security - Teachers PD	0.00	0.00	31.14	0.00	(31.14)	0.00	0.00
01 2214 231 002 0000 1 000	Elem Retirement - PD	0.00	0.00	78.98	0.00	(78.98)	0.00	0.00
01 2214 231 001 0000 2 000	HS Retirement - PD	0.00	0.00	36.40	0.00	(36.40)	0.00	0.00
01 2214 231 004 0000 3 000	MS Retirement - PD	0.00	0.00	40.26	0.00	(40.26)	0.00	0.00
01 2214 330 000 0000 0 000	Professional Development	0.00	0.00	0.00	0.00	0.00	0.00	0.00
01 2214 330 002 0000 1 000	TRANSPORTATION SERVICES	0.00	199.00	199.00	0.00	(199.00)	0.00	0.00
01 2214 330 001 0000 2 000	HS Employee Training & Development	0.00	289.00	589.00	0.00	(589.00)	0.00	0.00
01 2214 333 000 0000 0 000	Mileage	0.00	0.00	0.00	0.00	0.00	0.00	0.00
01 2214 333 001 0000 2 000	Mileage	0.00	0.00	0.00	0.00	0.00	0.00	0.00
01 2214 580 000 0000 0 000	INSERVICE EXPENSES	0.00	0.00	372.00	0.00	(372.00)	0.00	0.00
01 2214 610 000 0000 0 000	INSERVICE SUPPLIES	0.00	151.87	349.72	0.00	(349.72)	0.00	0.00
2214	Professional Development	0.00	639.87	3,538.23	0.00	(3,538.23)	0.00	0.00

BOARD EXPENDITURE REPORT BY FUNCTION

October 2018

Account Number	Account Description	Revised Budget	Expended During Month	Expenditures to Date	% of Budget	Balance at EOM	A/ P Outstanding	P/ O Outstanding
2220	Library/Media Services							
01 2220 111 002 0000 1 000	Elem Library/Media Teacher Salaries	0.00	5,510.00	11,020.00	0.00	(11,020.00)	0.00	0.00
01 2220 111 001 0000 2 000	HS Library/Media Teacher Salaries	0.00	2,958.00	5,916.00	0.00	(5,916.00)	0.00	0.00
01 2220 111 004 0000 3 000	Library/Media Teacher Salaries-MS	0.00	1,972.00	3,944.00	0.00	(3,944.00)	0.00	0.00
01 2220 211 002 0000 1 000	Elem Group Insurance - Library	0.00	609.08	1,709.08	0.00	(1,709.08)	0.00	0.00
01 2220 211 001 0000 2 000	HS Group Insurance - Library	0.00	843.34	1,686.68	0.00	(1,686.68)	0.00	0.00
01 2220 211 004 0000 3 000	MS Group Insurance Library	0.00	562.22	1,124.44	0.00	(1,124.44)	0.00	0.00
01 2220 221 002 0000 1 000	Elem Social Security - Library	0.00	421.52	843.04	0.00	(843.04)	0.00	0.00
01 2220 221 001 0000 2 000	HS Social Security - Library	0.00	223.89	447.78	0.00	(447.78)	0.00	0.00
01 2220 221 004 0000 3 000	MS Social Security - Librarian	0.00	149.26	298.52	0.00	(298.52)	0.00	0.00
01 2220 231 002 0000 1 000	El Retirement - Library	0.00	544.27	1,088.54	0.00	(1,088.54)	0.00	0.00
01 2220 231 001 0000 2 000	HS Retirement - Library	0.00	292.18	584.36	0.00	(584.36)	0.00	0.00
01 2220 231 004 0000 3 000	MS Retirement - Library	0.00	194.79	389.58	0.00	(389.58)	0.00	0.00
01 2220 281 001 0000 2 000	HS Health Benefits - Library	0.00	152.70	305.40	0.00	(305.40)	0.00	0.00
01 2220 281 004 0000 3 000	MS Health Benefits - Library	0.00	101.80	203.60	0.00	(203.60)	0.00	0.00
01 2220 610 002 0000 1 000	ELEM SUPPLIES	0.00	216.36	260.24	0.00	(260.24)	0.00	0.00
01 2220 610 002 0000 1 100	FURNITURE & EQUIPMENT	0.00	0.00	0.00	0.00	0.00	0.00	0.00
01 2220 610 001 0000 2 000	LIBRARY SUPPLIES	0.00	230.88	230.88	0.00	(230.88)	0.00	0.00
01 2220 610 004 0000 3 000	MS Library Supplies	0.00	136.29	136.29	0.00	(136.29)	0.00	0.00
01 2220 640 002 0000 1 000	LIBRARY BOOKS	0.00	0.00	60.00	0.00	(60.00)	0.00	0.00
01 2220 640 001 0000 2 000	HS Library Books & Periodicals	0.00	0.00	150.00	0.00	(150.00)	0.00	0.00
01 2220 640 004 0000 3 000	MS Library Books & Periodicals	0.00	0.00	210.00	0.00	(210.00)	0.00	0.00
2220	Library/Media Services	0.00	15,118.58	30,608.43	0.00	(30,608.43)	0.00	0.00
2224	Distance Education							
01 2224 382 001 0000 2 000	Telecommunications	0.00	672.24	672.24	0.00	(672.24)	0.00	0.00
2224	Distance Education	0.00	672.24	672.24	0.00	(672.24)	0.00	0.00
2310	Board of Education							
01 2310 330 000 0000 0 000	Training & Development	0.00	0.00	0.00	0.00	0.00	0.00	0.00
01 2310 540 000 0000 0 000	Board Advertising/Legal Notices	0.00	2,077.46	3,260.12	0.00	(3,260.12)	0.00	0.00
01 2310 643 000 0000 0 000	Sparq Software	0.00	0.00	666.64	0.00	(666.64)	0.00	0.00
01 2310 810 000 0000 0 000	DUES-FEES	0.00	850.00	850.00	0.00	(850.00)	0.00	0.00
2310	Board of Education	0.00	2,927.46	4,776.76	0.00	(4,776.76)	0.00	0.00
2320	Executive Administration							
01 2320 105 000 0000 0 000	SUPT SAL	0.00	11,400.00	22,800.00	0.00	(22,800.00)	0.00	0.00
01 2320 215 000 0000 0 000	SUPT Insurance	0.00	1,457.74	2,915.48	0.00	(2,915.48)	0.00	0.00
01 2320 225 000 0000 0 000	SUPT Soc Sec	0.00	871.34	1,756.65	0.00	(1,756.65)	0.00	0.00
01 2320 235 000 0000 0 000	SUPT RET	0.00	1,126.07	2,252.14	0.00	(2,252.14)	0.00	0.00
01 2320 285 000 0000 0 000	Supt HSA	0.00	254.50	509.00	0.00	(509.00)	0.00	0.00
01 2320 295 000 0000 0 000	Other Benefits	0.00	50.00	100.00	0.00	(100.00)	0.00	0.00
01 2320 330 000 0000 0 000	Training & Development	0.00	0.00	140.00	0.00	(140.00)	0.00	0.00
01 2320 333 000 0000 0 000	Mileage paid to parents	0.00	106.82	106.82	0.00	(106.82)	0.00	0.00
01 2320 350 000 0000 0 000	Advertising & Printing	0.00	0.00	2,795.00	0.00	(2,795.00)	0.00	0.00
01 2320 580 000 0000 0 000	TRAVEL	0.00	105.00	616.65	0.00	(616.65)	0.00	0.00
01 2320 610 000 0000 0 000	SUPPLIES	0.00	141.14	141.14	0.00	(141.14)	0.00	0.00
01 2320 810 000 0000 0 000	DUES-FEES	0.00	0.00	0.00	0.00	0.00	0.00	0.00
2320	Executive Administration	0.00	15,512.61	34,132.88	0.00	(34,132.88)	0.00	0.00
2330	Legal Services							
01 2330 317 000 0000 0 000	LEGAL SERVICES	0.00	769.50	1,307.50	0.00	(1,307.50)	0.00	0.00
2330	Legal Services	0.00	769.50	1,307.50	0.00	(1,307.50)	0.00	0.00
2410	Office of the Principal							
01 2410 110 002 0000 1 000	CLERICAL SAL	0.00	2,653.86	6,164.14	0.00	(6,164.14)	0.00	0.00

11/09/2018 03:20 PM

October 2018

User ID: GLS

Account Number	Account Description	Revised Budget	Expended During Month	Expenditures to Date	% of Budget	Balance at EOM	A/ P Outstanding	P/ O Outstanding
01 2410 110 001 0000 2 000	CLERICAL SAL	0.00	2,858.54	6,108.23	0.00	(6,108.23)	0.00	0.00
01 2410 110 004 0000 3 000	MS Clerical Salary	0.00	2,016.07	3,710.63	0.00	(3,710.63)	0.00	0.00
01 2410 111 002 0000 1 000	PRIN SAL	0.00	6,833.33	13,666.66	0.00	(13,666.66)	0.00	0.00
01 2410 111 001 0000 2 000	PRIN SAL	0.00	7,986.83	15,973.66	0.00	(15,973.66)	0.00	0.00
01 2410 111 004 0000 3 000	MS Principal Salary	0.00	7,038.33	14,076.66	0.00	(14,076.66)	0.00	0.00
01 2410 120 004 0000 3 000	MS Clerical Sub Salary	0.00	1,361.75	3,579.88	0.00	(3,579.88)	0.00	0.00
01 2410 130 002 0000 1 000	Overtime Non-Instructional Elem.	0.00	0.00	182.59	0.00	(182.59)	0.00	0.00
01 2410 130 001 0000 2 000	Overtime Non-Instructional HS	0.00	279.00	1,395.00	0.00	(1,395.00)	0.00	0.00
01 2410 210 002 0000 1 000	Group Insurance	0.00	13.22	26.44	0.00	(26.44)	0.00	0.00
01 2410 210 001 0000 2 000	Group Insurance	0.00	1,672.39	3,344.78	0.00	(3,344.78)	0.00	0.00
01 2410 210 004 0000 3 000	Group Insurance	0.00	11.10	22.20	0.00	(22.20)	0.00	0.00
01 2410 211 002 0000 1 000	BCBS	0.00	1,457.74	2,915.48	0.00	(2,915.48)	0.00	0.00
01 2410 211 001 0000 2 000	BCBS	0.00	1,712.24	3,424.48	0.00	(3,424.48)	0.00	0.00
01 2410 211 004 0000 3 000	MS Health Ins	0.00	1,691.57	3,383.14	0.00	(3,383.14)	0.00	0.00
01 2410 220 002 0000 1 000	SEC SUB Social Security	0.00	203.02	485.53	0.00	(485.53)	0.00	0.00
01 2410 220 001 0000 2 000	SEC SUB Social Security	0.00	236.03	566.02	0.00	(566.02)	0.00	0.00
01 2410 220 004 0000 3 000	MS Clerical Social Security	0.00	258.41	557.72	0.00	(557.72)	0.00	0.00
01 2410 221 002 0000 1 000	SOC SEC	0.00	526.58	1,067.14	0.00	(1,067.14)	0.00	0.00
01 2410 221 001 0000 2 000	SOC SEC	0.00	576.55	1,153.11	0.00	(1,153.11)	0.00	0.00
01 2410 221 004 0000 3 000	MS Soc Sec	0.00	523.89	1,047.79	0.00	(1,047.79)	0.00	0.00
01 2410 230 002 0000 1 000	Retirement	0.00	262.14	626.91	0.00	(626.91)	0.00	0.00
01 2410 230 001 0000 2 000	Retirement	0.00	309.92	741.16	0.00	(741.16)	0.00	0.00
01 2410 230 004 0000 3 000	Retirement	0.00	199.14	366.53	0.00	(366.53)	0.00	0.00
01 2410 231 002 0000 1 000	RETIREMENT	0.00	674.98	1,349.96	0.00	(1,349.96)	0.00	0.00
01 2410 231 001 0000 2 000	RETIREMENT	0.00	788.92	1,577.84	0.00	(1,577.84)	0.00	0.00
01 2410 231 004 0000 3 000	MS Retirement	0.00	695.23	1,390.46	0.00	(1,390.46)	0.00	0.00
01 2410 281 002 0000 1 000	Other Health Benefits	0.00	254.50	509.00	0.00	(509.00)	0.00	0.00
01 2410 291 002 0000 1 000	Other Benefits	0.00	50.00	100.00	0.00	(100.00)	0.00	0.00
01 2410 291 001 0000 2 000	Other Benefits	0.00	50.00	100.00	0.00	(100.00)	0.00	0.00
01 2410 291 004 0000 3 000	Other Benefits	0.00	50.00	100.00	0.00	(100.00)	0.00	0.00
01 2410 333 004 0000 3 000	Mileage	0.00	0.00	0.00	0.00	0.00	0.00	0.00
01 2410 580 002 0000 1 000	TRAVEL	0.00	0.00	389.85	0.00	(389.85)	0.00	0.00
01 2410 580 001 0000 2 000	Travel Expense	0.00	0.00	528.74	0.00	(528.74)	0.00	0.00
01 2410 610 002 0000 1 000	SUPPLIES	0.00	84.54	152.41	0.00	(152.41)	0.00	0.00
01 2410 610 001 0000 2 000	SUPPLIES	0.00	119.43	119.43	0.00	(119.43)	0.00	0.00
01 2410 610 004 0000 3 000	MS Supplies	0.00	954.07	1,019.44	0.00	(1,019.44)	0.00	0.00
01 2410 810 001 0000 2 000	DUES-FEES	0.00	0.00	20.00	0.00	(20.00)	0.00	0.00
01 2410 810 004 0000 3 000	MS Fees	0.00	0.00	20.00	0.00	(20.00)	0.00	0.00
2410 Office of the Principal		0.00	44,403.32	91,963.01	0.00	(91,963.01)	0.00	0.00
2490 Other Administration Salaries								
01 2490 111 000 0000 0 000	Activities Director Salary	0.00	4,402.50	8,805.00	0.00	(8,805.00)	0.00	0.00
01 2490 151 000 0000 0 000	Additional Comp Activities Director	0.00	833.33	1,666.66	0.00	(1,666.66)	0.00	0.00
01 2490 211 000 0000 0 000	Group Insurance - AD	0.00	609.08	1,218.16	0.00	(1,218.16)	0.00	0.00
01 2490 221 000 0000 0 000	Social Security - AD	0.00	400.54	815.06	0.00	(815.06)	0.00	0.00
01 2490 231 000 0000 0 000	Retirement - AD	0.00	517.19	1,034.38	0.00	(1,034.38)	0.00	0.00
2490 Other Administration Salaries		0.00	6,762.64	13,539.26	0.00	(13,539.26)	0.00	0.00
2510 Fiscal Services								
01 2510 110 000 0000 0 000	SEC SAL	0.00	7,542.47	16,201.47	0.00	(16,201.47)	0.00	0.00
01 2510 130 000 0000 0 000	Overtime Non-Instructional	0.00	3,804.87	7,925.10	0.00	(7,925.10)	0.00	0.00
01 2510 210 000 0000 0 000	Group Insurance Bookkeeper	0.00	1,444.02	2,886.91	0.00	(2,886.91)	0.00	0.00
01 2510 220 000 0000 0 000	Social Security	0.00	868.07	1,845.68	0.00	(1,845.68)	0.00	0.00
01 2510 230 000 0000 0 000	Retirement	0.00	1,120.86	2,383.16	0.00	(2,383.16)	0.00	0.00
01 2510 280 000 0000 0 000	Other Health Benefits	0.00	254.50	509.00	0.00	(509.00)	0.00	0.00

BOARD EXPENDITURE REPORT BY FUNCTION

October 2018

Account Number	Account Description	Revised Budget	Expended During Month	Expenditures to Date	% of Budget	Balance at EOM	A/ P Outstanding	P/ O Outstanding
01 2510 330 000 0000 0 000	Training & Development	0.00	0.00	60.00	0.00	(60.00)	0.00	0.00
01 2510 520 000 0000 0 000	Property Insurance	0.00	0.00	6,452.46	0.00	(6,452.46)	0.00	0.00
01 2510 530 000 0000 0 000	Telecommunications District	0.00	1,521.44	2,999.40	0.00	(2,999.40)	0.00	0.00
01 2510 530 002 0000 1 000	Elem Telecommunications Albion	0.00	258.75	517.50	0.00	(517.50)	0.00	0.00
01 2510 530 001 0000 2 000	HS Telecommunications Albion	0.00	258.76	517.52	0.00	(517.52)	0.00	0.00
01 2510 530 001 1116 2 000	Pathways Telecommunications	0.00	57.50	115.00	0.00	(115.00)	0.00	0.00
01 2510 530 004 0000 3 000	Telecommunications Petersburg	0.00	219.59	439.18	0.00	(439.18)	0.00	0.00
01 2510 531 002 0000 1 000	Elem Postage	0.00	58.50	521.53	0.00	(521.53)	0.00	0.00
01 2510 531 001 0000 2 000	HS Postage	0.00	58.50	521.54	0.00	(521.54)	0.00	0.00
01 2510 540 000 0000 0 000	Advertising	0.00	0.00	0.00	0.00	0.00	0.00	0.00
01 2510 580 000 0000 0 000	Travel Expense	0.00	95.00	215.00	0.00	(215.00)	0.00	0.00
01 2510 610 000 0000 0 000	Supplies	0.00	32.37	391.85	0.00	(391.85)	0.00	0.00
01 2510 650 000 0000 0 000	Business Office Technology	0.00	0.00	0.00	0.00	0.00	0.00	0.00
01 2510 810 000 0000 0 000	Dues & Fees	0.00	30.00	30.00	0.00	(30.00)	0.00	0.00
2510 Fiscal Services		0.00	17,625.20	44,532.30	0.00	(44,532.30)	0.00	0.00
2515 Building & Sites								
01 2515 450 000 0000 0 000	Construction Services	0.00	0.00	6,300.00	0.00	(6,300.00)	0.00	0.00
01 2515 490 000 0000 0 000	Other	0.00	0.00	725.00	0.00	(725.00)	0.00	0.00
2515 Building & Sites		0.00	0.00	7,025.00	0.00	(7,025.00)	0.00	0.00
2560 Public Information Services								
01 2560 643 000 0000 0 000	Website/Messenger System	0.00	2,399.00	4,353.70	0.00	(4,353.70)	0.00	0.00
2560 Public Information Services		0.00	2,399.00	4,353.70	0.00	(4,353.70)	0.00	0.00
2570 Personnel Services								
01 2570 340 000 0000 0 000	Background Checks	0.00	164.50	211.50	0.00	(211.50)	0.00	0.00
2570 Personnel Services		0.00	164.50	211.50	0.00	(211.50)	0.00	0.00
2580 Administrative Tech Services								
01 2580 114 000 0000 0 000	Salaries - Technical Staff	0.00	3,624.53	7,800.99	0.00	(7,800.99)	0.00	0.00
01 2580 134 000 0000 0 000	Overtime Technical Staff	0.00	93.89	281.66	0.00	(281.66)	0.00	0.00
01 2580 151 004 0000 3 000	LAN Manager MS	0.00	130.50	261.00	0.00	(261.00)	0.00	0.00
01 2580 214 000 0000 0 000	Group Insurance Technical Staff	0.00	625.93	1,251.86	0.00	(1,251.86)	0.00	0.00
01 2580 221 004 0000 3 000	MS Social Security - Teachers LAN	0.00	9.98	19.96	0.00	(19.96)	0.00	0.00
01 2580 224 000 0000 0 000	Social Security Technical Staff	0.00	284.46	618.32	0.00	(618.32)	0.00	0.00
01 2580 231 004 0000 3 000	MS Retirement - Tech	0.00	12.89	25.78	0.00	(25.78)	0.00	0.00
01 2580 234 000 0000 0 000	Retirement - Tech	0.00	367.30	798.39	0.00	(798.39)	0.00	0.00
01 2580 432 000 0000 0 000	Tech Mainenance	0.00	0.00	0.00	0.00	0.00	0.00	0.00
01 2580 650 000 0000 0 000	Tech Supplies	0.00	0.00	288.62	0.00	(288.62)	0.00	0.00
2580 Administrative Tech Services		0.00	5,149.48	11,346.58	0.00	(11,346.58)	0.00	0.00
2610 Operation of Buildings								
01 2610 110 002 0000 1 000	SALARY CUSTODIAN	0.00	8,663.49	18,564.98	0.00	(18,564.98)	0.00	0.00
01 2610 110 001 0000 2 000	SALARY CUSTODIAN	0.00	8,795.42	18,834.41	0.00	(18,834.41)	0.00	0.00
01 2610 110 004 0000 3 000	MS Custodian Salary	0.00	6,044.45	14,014.05	0.00	(14,014.05)	0.00	0.00
01 2610 120 004 0000 3 000	Salaries - MS Sub Custodian	0.00	224.00	328.00	0.00	(328.00)	0.00	0.00
01 2610 130 002 0000 1 000	Overtime Custodial	0.00	1,921.11	4,402.82	0.00	(4,402.82)	0.00	0.00
01 2610 130 001 0000 2 000	Overtime Custodial	0.00	1,921.11	4,402.84	0.00	(4,402.84)	0.00	0.00
01 2610 130 004 0000 3 000	Overtime Custodial MS	0.00	252.15	252.15	0.00	(252.15)	0.00	0.00
01 2610 210 002 0000 1 000	Elem Group Insurance - Custodian	0.00	3,134.87	6,269.78	0.00	(6,269.78)	0.00	0.00
01 2610 210 001 0000 2 000	HS Group Insurance - Custodian	0.00	3,156.27	6,337.79	0.00	(6,337.79)	0.00	0.00
01 2610 210 004 0000 3 000	MS Group Insurance - Custodian	0.00	1,273.37	2,683.80	0.00	(2,683.80)	0.00	0.00
01 2610 220 002 0000 1 000	Elem Social Security - Custodian	0.00	793.33	1,724.24	0.00	(1,724.24)	0.00	0.00
01 2610 220 001 0000 2 000	HS Social Security - Custodian	0.00	803.41	1,744.72	0.00	(1,744.72)	0.00	0.00
01 2610 220 004 0000 3 000	Social Security	0.00	496.42	1,111.64	0.00	(1,111.64)	0.00	0.00

BOARD EXPENDITURE REPORT BY FUNCTION

October 2018

Account Number	Account Description	Revised Budget	Expended During Month	Expenditures to Date	% of Budget	Balance at EOM	A/ P Outstanding	P/ O Outstanding
01 2610 230 002 0000 1 000	Elem Retirement Custodian	0.00	1,045.52	2,268.71	0.00	(2,268.71)	0.00	0.00
01 2610 230 001 0000 2 000	HS Retirement Custodian	0.00	1,058.55	2,295.33	0.00	(2,295.33)	0.00	0.00
01 2610 230 004 0000 3 000	MS Retirement - Custodian	0.00	621.97	1,368.30	0.00	(1,368.30)	0.00	0.00
01 2610 280 004 0000 3 000	Other Health Benefits	0.00	0.00	23.98	0.00	(23.98)	0.00	0.00
01 2610 410 000 0000 0 000	WATER/GARBAGE	0.00	81.30	81.30	0.00	(81.30)	0.00	0.00
01 2610 410 002 0000 1 000	WATER/GARBAGE	0.00	1,818.91	1,818.91	0.00	(1,818.91)	0.00	0.00
01 2610 410 001 0000 2 000	WATER/GARBAGE	0.00	2,185.04	2,185.04	0.00	(2,185.04)	0.00	0.00
01 2610 410 001 1116 2 000	WATER AND SEWER	0.00	138.61	138.61	0.00	(138.61)	0.00	0.00
01 2610 410 004 0000 3 000	MS Water&Garbage	0.00	0.00	0.00	0.00	0.00	0.00	0.00
01 2610 430 000 0000 0 000	Repairs Albion	0.00	0.00	0.00	0.00	0.00	0.00	0.00
01 2610 430 001 1116 0 000	Pathways Repairs	0.00	1,177.94	1,177.94	0.00	(1,177.94)	0.00	0.00
01 2610 430 002 0000 1 000	Contracted Repair Services Elem	0.00	0.00	2,707.95	0.00	(2,707.95)	0.00	0.00
01 2610 430 001 0000 2 000	Contracted Repair Services HS	0.00	665.70	4,351.80	0.00	(4,351.80)	0.00	0.00
01 2610 430 001 1116 2 000	PATHWAYS MAINT AGREEMENTS	0.00	544.87	544.87	0.00	(544.87)	0.00	0.00
01 2610 430 004 0000 3 000	MS Cust Contracted Services	0.00	2,100.53	2,100.53	0.00	(2,100.53)	0.00	0.00
01 2610 431 002 0000 1 000	Elem. Service Agreements	0.00	3,267.68	3,699.20	0.00	(3,699.20)	0.00	0.00
01 2610 431 001 0000 2 000	HS Service Agreements	0.00	3,267.69	3,699.20	0.00	(3,699.20)	0.00	0.00
01 2610 431 001 1116 2 000	Pathways Maint. Agreements	0.00	34.97	69.94	0.00	(69.94)	0.00	0.00
01 2610 431 004 0000 3 000	Service Agreements	0.00	254.23	452.02	0.00	(452.02)	0.00	0.00
01 2610 442 002 0000 1 000	Equipment Rental	0.00	0.00	0.00	0.00	0.00	0.00	0.00
01 2610 442 001 0000 2 000	Equipment Rental	0.00	0.00	0.00	0.00	0.00	0.00	0.00
01 2610 450 001 1116 2 000	Construction Services	0.00	0.00	0.00	0.00	0.00	0.00	0.00
01 2610 610 000 0000 0 000	SUPPLIES	0.00	0.00	2,487.63	0.00	(2,487.63)	0.00	0.00
01 2610 610 002 0000 1 000	Supplies	0.00	1,284.11	2,405.04	0.00	(2,405.04)	0.00	0.00
01 2610 610 001 0000 2 000	HS Supplies	0.00	1,542.54	3,142.54	0.00	(3,142.54)	0.00	0.00
01 2610 610 001 1116 2 000	Pathways Supplies	0.00	0.00	650.01	0.00	(650.01)	0.00	0.00
01 2610 610 004 0000 3 000	MS Cust Supplies	0.00	124.07	221.43	0.00	(221.43)	0.00	0.00
01 2610 621 000 0000 0 000	Fuel	0.00	59.22	118.44	0.00	(118.44)	0.00	0.00
01 2610 621 002 0000 1 000	FUEL	0.00	268.86	401.87	0.00	(401.87)	0.00	0.00
01 2610 621 001 0000 2 000	FUEL	0.00	268.86	401.86	0.00	(401.86)	0.00	0.00
01 2610 621 001 1116 2 000	Pathways Fuel	0.00	79.95	122.60	0.00	(122.60)	0.00	0.00
01 2610 621 004 0000 3 000	MS Natural Gas	0.00	352.66	574.61	0.00	(574.61)	0.00	0.00
01 2610 622 000 0000 0 000	ELECTRICITY	0.00	105.57	183.79	0.00	(183.79)	0.00	0.00
01 2610 622 002 0000 1 000	Electricity	0.00	3,484.26	6,582.91	0.00	(6,582.91)	0.00	0.00
01 2610 622 001 0000 2 000	Electricity	0.00	11,372.41	18,919.34	0.00	(18,919.34)	0.00	0.00
01 2610 622 001 1116 2 000	Pathways Electricity	0.00	112.37	211.76	0.00	(211.76)	0.00	0.00
01 2610 622 004 0000 3 000	MS Electricity	0.00	1,587.20	2,336.00	0.00	(2,336.00)	0.00	0.00
01 2610 626 002 0000 1 000	Elem Gas	0.00	103.74	306.08	0.00	(306.08)	0.00	0.00
01 2610 626 001 0000 2 000	HS Gas	0.00	103.74	306.08	0.00	(306.08)	0.00	0.00
01 2610 626 004 0000 3 000	Gas & Oil Petersburg	0.00	0.00	138.38	0.00	(138.38)	0.00	0.00
2610	Operation of Buildings	0.00	76,592.47	149,165.22	0.00	(149,165.22)	0.00	0.00
2660	Security							
01 2660 340 000 0000 0 000	Other Professional Services	0.00	0.00	0.00	0.00	0.00	0.00	0.00
01 2660 340 004 0000 3 000	Other Professional Services	0.00	0.00	0.00	0.00	0.00	0.00	0.00
01 2660 610 000 0000 0 000	Safety Supplies	0.00	0.00	2,250.00	0.00	(2,250.00)	0.00	0.00
2660	Security	0.00	0.00	2,250.00	0.00	(2,250.00)	0.00	0.00
2670	Safety							
01 2670 151 000 0000 0 000	Safety Coordinator Salaries	0.00	81.20	162.40	0.00	(162.40)	0.00	0.00
01 2670 221 000 0000 0 000	Social Security - Teachers Safety	0.00	6.21	12.43	0.00	(12.43)	0.00	0.00
01 2670 231 000 0000 0 000	Retirement - Teacher Safety	0.00	8.02	16.03	0.00	(16.03)	0.00	0.00
01 2670 430 001 0000 2 000	Repairs	0.00	0.00	0.00	0.00	0.00	0.00	0.00
01 2670 431 004 0000 3 000	MS Safety Service Agreements	0.00	0.00	288.50	0.00	(288.50)	0.00	0.00
2670	Safety	0.00	95.43	479.36	0.00	(479.36)	0.00	0.00

BOARD EXPENDITURE REPORT BY FUNCTION

October 2018

Account Number	Account Description	Revised Budget	Expended During Month	Expenditures to Date	% of Budget	Balance at EOM	A/ P Outstanding	P/ O Outstanding
2710	Regular Pupil Transportation							
01 2710 110 000 0000 0 000	BUS DRIVER SALARY	0.00	4,564.40	8,324.78	0.00	(8,324.78)	0.00	0.00
01 2710 110 000 0000 0 600	Salaries - Scheduling Trans	0.00	690.80	1,260.71	0.00	(1,260.71)	0.00	0.00
01 2710 110 002 0000 1 000	Salaries - Elem Activity Drivers	0.00	266.57	576.61	0.00	(576.61)	0.00	0.00
01 2710 110 001 0000 2 000	Salaries - HS Activity Driver	0.00	228.90	547.64	0.00	(547.64)	0.00	0.00
01 2710 110 004 0000 3 000	Salaries - MS Activities	0.00	601.52	1,349.57	0.00	(1,349.57)	0.00	0.00
01 2710 110 004 0000 3 500	Salaries -MS Route Driver	0.00	2,774.66	4,382.58	0.00	(4,382.58)	0.00	0.00
01 2710 120 000 0000 0 000	Salaries - Bus Driver Substitutes	0.00	513.83	592.88	0.00	(592.88)	0.00	0.00
01 2710 120 004 0000 3 500	Salaries - MS Route Driver Sub	0.00	260.87	308.30	0.00	(308.30)	0.00	0.00
01 2710 130 001 0000 2 000	Overtime Activity Transportation	0.00	2,024.20	2,335.48	0.00	(2,335.48)	0.00	0.00
01 2710 151 000 0000 0 000	Transportation Coordinator	0.00	87.00	174.00	0.00	(174.00)	0.00	0.00
01 2710 210 000 0000 0 000	Group Insurance Bus Driver	0.00	252.78	624.49	0.00	(624.49)	0.00	0.00
01 2710 210 001 0000 2 000	HS Group Insurance - Bus Driver	0.00	278.21	376.23	0.00	(376.23)	0.00	0.00
01 2710 210 004 0000 3 500	MS Group Insurance - Bus Driver	0.00	127.19	315.64	0.00	(315.64)	0.00	0.00
01 2710 220 000 0000 0 000	Social Security-Bus Driver	0.00	384.19	671.58	0.00	(671.58)	0.00	0.00
01 2710 220 000 0000 0 600	Social Security - Bus Scheduling	0.00	52.85	96.44	0.00	(96.44)	0.00	0.00
01 2710 220 002 0000 1 000	Elem Social Security- Bus Drivers	0.00	20.39	44.11	0.00	(44.11)	0.00	0.00
01 2710 220 001 0000 2 000	HS Social Security -Bus Drivers	0.00	167.30	213.71	0.00	(213.71)	0.00	0.00
01 2710 220 004 0000 3 000	MS Social Security- Bus Drivers	0.00	46.02	103.25	0.00	(103.25)	0.00	0.00
01 2710 220 004 0000 3 500	MS Social Security - Bus Driver	0.00	229.65	352.49	0.00	(352.49)	0.00	0.00
01 2710 221 000 0000 0 000	SOC SEC	0.00	6.65	13.30	0.00	(13.30)	0.00	0.00
01 2710 230 000 0000 0 000	Retirement	0.00	402.14	745.90	0.00	(745.90)	0.00	0.00
01 2710 230 000 0000 0 600	Retirement - Bus Schedule	0.00	68.24	124.53	0.00	(124.53)	0.00	0.00
01 2710 230 002 0000 1 000	Elem Retirement - Bus Driver	0.00	12.59	43.21	0.00	(43.21)	0.00	0.00
01 2710 230 001 0000 2 000	HS Retirement - Bus Driver	0.00	222.55	284.79	0.00	(284.79)	0.00	0.00
01 2710 230 004 0000 3 000	MS Retirement - Bus Driver	0.00	52.55	126.44	0.00	(126.44)	0.00	0.00
01 2710 230 004 0000 3 500	MS Retirement Bus Driver	0.00	276.42	435.25	0.00	(435.25)	0.00	0.00
01 2710 231 000 0000 0 000	RETIREMENT	0.00	8.59	17.18	0.00	(17.18)	0.00	0.00
01 2710 340 000 0000 0 000	Professional Services for Drivers	0.00	0.00	100.00	0.00	(100.00)	0.00	0.00
2710	Regular Pupil Transportation	0.00	14,621.06	24,541.09	0.00	(24,541.09)	0.00	0.00
2712	Vehicle Operation - School Age SpEd							
01 2712 112 002 0000 1 000	Elem Sped Transportation	0.00	409.64	643.72	0.00	(643.72)	0.00	0.00
01 2712 112 001 0000 2 000	SPED TRANSPORTATION	0.00	409.64	643.72	0.00	(643.72)	0.00	0.00
01 2712 212 002 0000 1 000	Group Insurance	0.00	2.35	7.16	0.00	(7.16)	0.00	0.00
01 2712 212 001 0000 2 000	Group Insurance	0.00	2.35	7.16	0.00	(7.16)	0.00	0.00
01 2712 222 002 0000 1 000	Social Security	0.00	31.34	49.25	0.00	(49.25)	0.00	0.00
01 2712 222 001 0000 2 000	Social Security	0.00	31.34	49.25	0.00	(49.25)	0.00	0.00
01 2712 332 002 0000 1 000	MILEAGE TO PARENTS	0.00	318.83	318.83	0.00	(318.83)	0.00	0.00
2712	Vehicle Operation - School Age SpEd	0.00	1,205.49	1,719.09	0.00	(1,719.09)	0.00	0.00
2713	Vehicle Operation - Below Age 5 SpEd							
01 2713 112 002 0000 1 000	Preschool Transportation	0.00	119.15	229.49	0.00	(229.49)	0.00	0.00
01 2713 212 002 0000 1 000	PS Group Insurance -Sped Transportation	0.00	0.52	1.04	0.00	(1.04)	0.00	0.00
01 2713 222 002 0000 1 000	PS Social Security - Driver	0.00	9.12	17.56	0.00	(17.56)	0.00	0.00
01 2713 232 002 0000 1 000	PS Retirement- Sped Transportation	0.00	11.77	22.67	0.00	(22.67)	0.00	0.00
2713	Vehicle Operation - Below Age 5 SpEd	0.00	140.56	270.76	0.00	(270.76)	0.00	0.00
2730	Vehicle Servicing & Maintenance - Reg Ed							
01 2730 110 000 0000 0 000	Salaries - Bus Maintenance Trips	0.00	225.55	382.02	0.00	(382.02)	0.00	0.00
01 2730 220 000 0000 0 000	Social Security - Drivers	0.00	17.25	29.21	0.00	(29.21)	0.00	0.00

BOARD EXPENDITURE REPORT BY FUNCTION

October 2018

Account Number	Account Description	Revised Budget	Expended During Month	Expenditures to Date	% of Budget	Balance at EOM	A/ P Outstanding	P/ O Outstanding
	(Maintenance)							
01 2730 230 000 0000 0 000	Retirement Bus Drivers (Maintenance)	0.00	19.41	34.86	0.00	(34.86)	0.00	0.00
01 2730 430 000 0000 0 000	Repairs	0.00	1,590.71	12,721.47	0.00	(12,721.47)	0.00	0.00
01 2730 520 000 0000 0 000	Insurance	0.00	0.00	1,383.09	0.00	(1,383.09)	0.00	0.00
01 2730 610 000 0000 0 000	Vehicle Supplies	0.00	264.77	460.48	0.00	(460.48)	0.00	0.00
01 2730 626 000 0000 0 000	Gasoline & diesel fuel	0.00	6,802.03	9,973.86	0.00	(9,973.86)	0.00	0.00
01 2730 810 000 0000 0 000	Dues & Fees	0.00	20.00	22.00	0.00	(22.00)	0.00	0.00
2730	Vehicle Servicing & Maintenance - Reg Ed	0.00	8,939.72	25,006.99	0.00	(25,006.99)	0.00	0.00
3300	Community Service - CKC							
01 3300 112 002 0000 1 000	Salaries- CKC	0.00	657.50	657.50	0.00	(657.50)	0.00	0.00
01 3300 122 002 0000 1 000	Salaries - Substitute Aide CKC	0.00	71.25	71.25	0.00	(71.25)	0.00	0.00
01 3300 222 002 0000 1 000	Social Security - CKC	0.00	55.76	55.76	0.00	(55.76)	0.00	0.00
01 3300 610 002 0000 1 000	Supplies-CKC	0.00	448.40	448.40	0.00	(448.40)	0.00	0.00
3300	Community Service - CKC	0.00	1,232.91	1,232.91	0.00	(1,232.91)	0.00	0.00
3400	Categorical Grant							
01 3400 610 002 0000 1 000	PROFESSIONAL/TECHNICAL SERV	0.00	0.00	79.79	0.00	(79.79)	0.00	0.00
01 3400 610 004 0000 3 000	Supplies	0.00	117.70	117.70	0.00	(117.70)	0.00	0.00
3400	Categorical Grant	0.00	117.70	197.49	0.00	(197.49)	0.00	0.00
3535	High Ability Learners							
01 3535 111 004 0000 3 000	HAL Salaries-Teachers MS	0.00	1,102.00	2,204.00	0.00	(2,204.00)	0.00	0.00
01 3535 211 004 0000 3 000	MS Group Insurance HAL	0.00	351.39	702.78	0.00	(702.78)	0.00	0.00
01 3535 221 004 0000 3 000	MS Social Security - Teachers HAL	0.00	83.30	170.09	0.00	(170.09)	0.00	0.00
01 3535 231 004 0000 3 000	MS Retirement - Teachers HAL	0.00	108.85	217.70	0.00	(217.70)	0.00	0.00
01 3535 281 004 0000 3 000	MS Health Benefits HAL	0.00	63.63	127.26	0.00	(127.26)	0.00	0.00
01 3535 810 002 0000 1 000	DUES AND FEES	0.00	142.00	142.00	0.00	(142.00)	0.00	0.00
01 3535 810 004 0000 3 000	Dues and Fees	0.00	442.00	442.00	0.00	(442.00)	0.00	0.00
3535	High Ability Learners	0.00	2,293.17	4,005.83	0.00	(4,005.83)	0.00	0.00
3575	Afterschool Program							
01 3575 112 002 0000 1 000	Afterschool Salaries	0.00	3,310.00	8,567.80	0.00	(8,567.80)	0.00	0.00
01 3575 212 002 0000 1 000	Group Insurance	0.00	16.25	32.94	0.00	(32.94)	0.00	0.00
01 3575 222 002 0000 1 000	Social Security	0.00	253.21	655.45	0.00	(655.45)	0.00	0.00
01 3575 232 002 0000 1 000	Retirement	0.00	107.67	256.82	0.00	(256.82)	0.00	0.00
01 3575 610 002 0000 1 000	Afterschool Supplies	0.00	141.93	1,172.76	0.00	(1,172.76)	0.00	0.00
3575	Afterschool Program	0.00	3,829.06	10,685.77	0.00	(10,685.77)	0.00	0.00
6200	Title I							
01 6200 111 002 0000 1 000	Title I Teaching Salary	0.00	3,696.69	7,393.38	0.00	(7,393.38)	0.00	0.00
01 6200 211 002 0000 1 000	Health Insurance	0.00	1,322.56	2,645.12	0.00	(2,645.12)	0.00	0.00
01 6200 221 002 0000 1 000	Social Security	0.00	279.61	559.22	0.00	(559.22)	0.00	0.00
01 6200 231 002 0000 1 000	Retirement	0.00	365.15	730.30	0.00	(730.30)	0.00	0.00
6200	Title I	0.00	5,664.01	11,328.02	0.00	(11,328.02)	0.00	0.00
6310	Title IIA							
01 6310 330 000 0000 0 000	Employee Training & Development	0.00	0.00	11,200.00	0.00	(11,200.00)	0.00	0.00
01 6310 340 000 0000 0 000	Contracted or Secured Services	0.00	0.00	0.00	0.00	0.00	0.00	0.00
01 6310 580 000 0000 0 000	Travel Expenses	0.00	0.00	(61.23)	0.00	61.23	0.00	0.00
6310	Title IIA	0.00	0.00	11,138.77	0.00	(11,138.77)	0.00	0.00
6404	IDEA 0-4							
01 6404 340 002 0000 1 000	Other Professional Services	0.00	0.00	0.00	0.00	0.00	0.00	0.00
01 6404 591 002 0000 1 000	Purchased Services from ESU	0.00	2,168.04	2,168.04	0.00	(2,168.04)	0.00	0.00
6404	IDEA 0-4	0.00	2,168.04	2,168.04	0.00	(2,168.04)	0.00	0.00
6406	IDEA 3-4							

BOARD EXPENDITURE REPORT BY FUNCTION

October 2018

Account Number	Account Description	Revised Budget	Expended During Month	Expenditures to Date	% of Budget	Balance at EOM	A/ P Outstanding	P/ O Outstanding
01 6406 112 002 0000 1 000	SpED Salaries-Instructional Aides 3-4	0.00	846.13	1,648.98	0.00	(1,648.98)	0.00	0.00
01 6406 212 002 0000 1 000	PS Group Insurance - Instructional Aides	0.00	287.34	574.65	0.00	(574.65)	0.00	0.00
01 6406 222 002 0000 1 000	PS Social Security - Instructional Aides	0.00	61.16	119.01	0.00	(119.01)	0.00	0.00
01 6406 232 002 0000 1 000	PS Retirement Instructional Aides	0.00	83.58	162.88	0.00	(162.88)	0.00	0.00
01 6406 591 002 0000 1 000	Purchased Services from ESU	0.00	88.23	88.23	0.00	(88.23)	0.00	0.00
6406 IDEA 3-4		0.00	1,366.44	2,593.75	0.00	(2,593.75)	0.00	0.00
Grand Total:		0.00	724,652.68	1,498,363.80	0.00	(1,498,363.80)	0.00	0.00

Board & Administrator

FOR SCHOOL BOARD MEMBERS

October 2018 Vol. 32, No. 6

Editor: Jeff Stratton

Increase student achievement with an 'aligned' district

In an education career that began with teaching second-graders and led to sitting in the superintendent's chair, Dr. Peter Gorman came to believe that school districts whose governance and management is aligned can deliver better student achievement.

What does this mean for a school district? As Gorman puts it: "Responsibility is much more powerful than accountability. Someone else imposes accountability on you, but responsibility comes from yourself internally."

Here's more from Gorman:

In my experience and through my observations and research, I've noticed that the school districts that have done the best work increasing student achievement at scale were what I call aligned systems. These are school districts where a number of elements are working in an aligned way so that one element supports and compounds the other elements of the system. I use the word *compounds* like compound interest. For example, two elements added together don't only equal the value of the two elements but create an even greater number over time because working together, they make each other more effective and add up to even more.

As a superintendent, I worked to align the school district, creating a climate and culture that allowed us to put in place systems, processes, and structures that supported us working together as a team to increase student achievement, raising the bar for all students and closing achievement

gaps while increasing the number of students graduating college- and/or career-ready.

The graphic below shows the elements of an aligned school system. ■

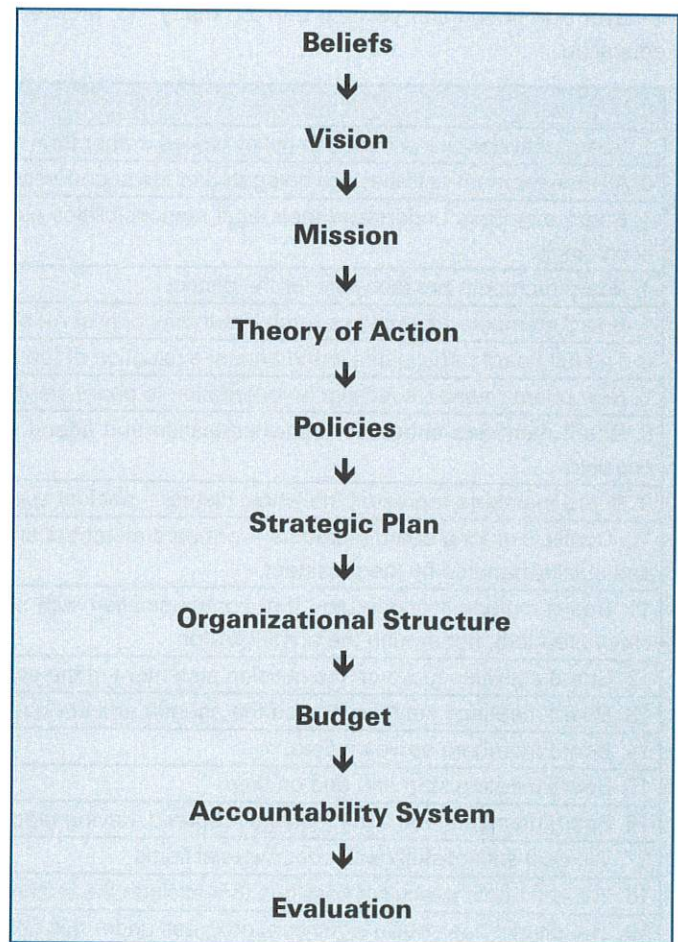

Board member: Do we have enough money?

“Are we getting ourselves into financial trouble?”

This is a question most boards wrestle with at one time or another. And since not all board members are financial wizards, some members may feel they are on thin ice when it comes to asking questions about the district’s finances.

Here are three questions boards can ask their superintendent to find answers and ease their worries.

1. Do we have a financial “cushion”? Money in the bank not only provides a financial cushion, but also a mental cushion for board members. As a board member, I’d feel much better adding up liabilities for the next 30 days (utilities, payment on debt, payroll), subtracting that from money on hand, and knowing we had a financial cushion.

2. Are revenues and expenses in line with projections? Ask your superintendent for a variance report summary. This report will show board members how revenues and expenses have been meeting the board’s budgeted expectations.

With a glance at a variance report, board members can see where revenues stand in relation to budget projections, how expenses compare to budget, and where the district stands overall in net income in relation to budget.

3. How will we end the year? Consider asking for a projection about whether the district will finish with a year-end surplus or loss.

Tip: Consider a board work/study session during the year and ask your superintendent to make financial updates and education part of the agenda. ■

How effective and successful is your board? Let’s find out!

Key: Check “Yes” if the statement is true all the time. Check “Some” if the item is at least partially true. Check “No” if the item is never true. If you find yourself with too many “no” answers, speak with your superintendent about arranging some board education.

	Yes	Some	No
1. Board activities are confined to policy issues, rather than management issues.			
2. All management activities are delegated to the superintendent.			
3. Board members understand their legal responsibilities as trustees of the school district and act accordingly.			
4. Board members are lobbyists for the district.			
5. Board members attempt to exercise authority only at meetings.			
6. The full board participates in the annual evaluation of the superintendent.			
7. New board members receive an orientation to board service.			
8. Board members budget for board education and attend state and national opportunities when possible.			
9. Board members represent the whole district -- not just special interest groups.			
10. Conflicts among board members -- or board members and the superintendent -- are addressed and quickly handled by the president.			
11. Board members understand that communication with staff should be channeled through the superintendent, not around the administrator.			
12. Board activities focus on the mission statement of the school district.			
13. Board meetings stay focused on the agenda and are businesslike.			
14. Board members arrive on time.			
15. Board meeting start and end on time.			
16. Board members come to meetings prepared, having read the agenda and supporting materials.			
17. We deal successfully with controversial items.			
18. We don’t hold executive sessions that exclude the superintendent.			
19. The district has shown significant progress under this board’s leadership.			
20. Board members are satisfied with the overall operation of the board.			



Board Report - Craig Theis
as of November 12th, 2018

Elementary Principal's Update

1. Classroom Updates:

- A. 1st grade students at Boone Central Elementary School were able to be part of a virtual field trip presentation called "Elephants in America: Past, Present and Future". This VFT was hosted from two locations in Nebraska; Omaha's Henry Doorly Zoo & Aquarium and the University of Nebraska State Museum. African elephants that are on exhibit at the zoo were compared to the world's largest fossil mammoth skeleton at Morrill Hall to take a deeper look at elephant behavior, adaptive features, and conservation needs. Boone Central Elementary 1st graders were given the distinction of being one of the three on-camera classes that were viewing. Fifty-five K-12 schools in Nebraska and surrounding areas participated in this free educational experience.



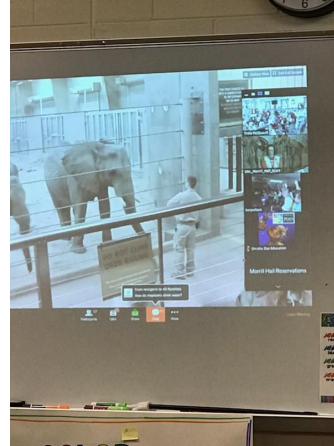
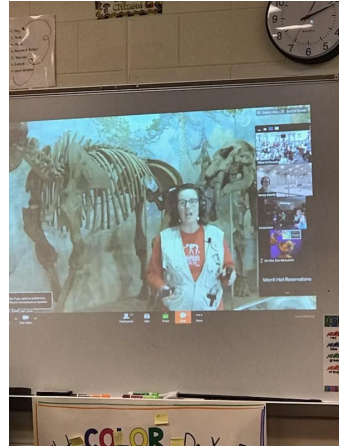

B. We had our 2nd Rockin' Rally on October 26th. We honored a Kind Cardinal from each classroom that displayed "OWNERSHIP". Students were also honored for Morning Fitness Attendance, Rockin' Readers and Birthdays. We finished our assembly with a Minute to Win It game.



D. Upcoming Events:

- **Thanksgiving Break: November 21st**
- **Rockin' Rally: November 30th (Cooperation)**



Board Report - BCMS October 12, 2018

Middle School Update

Middle School Character Retreat – October 22

- The day was full of great lessons about being a good person, leader, and friend. The keynote speaker, Scott Backovich, is a nationally known speaker from California that usually speaks to groups of 1,000 to 10,000 people. However, this opportunity was unique for not only him but our students as well. His message was the following: Being a person of good character comes from yourself. He also challenged each student with the following question: What's stopping you from making a difference or making a change? Our students responded great to his message, and it's something that I look forward to using throughout the rest of this school year and into the future with our students at BCMS.
- National Honors Society members from the high school were up to help all day. Our students look up to them, and they are great role models for our students.
- Students had the opportunity to listen to a member of the Nebraska National Guard speak to them about the qualities of a person that joins the National Guard. Not only that, students were able to try MRE's and release some energy with some blow up carnival type games that the National Guard provided.
- This is the 5th year of the Character Retreat at BCMS

Middle School Winter Sports

- 7/8 girls basketball and wrestling have started this month already. There are about 24 girls out for basketball, and about 20 out for middle school wrestling.

Curriculum/Assessment Update

Assessment

- **NSCAS Results:** NSCAS results are in, but they cannot be released until November. However, results can be shared with staff. Individual Student Reports can be sent home to parents as well. These reports will be sent home on November 19th and 20th in the mail.
- Elementary and Middle School staff have been given a presentation as to how the new scores look and should be read. Graphs created from testing data have been created and are currently being looked at by collaborative teams during PLC time.
- Once the public embargo is lifted, results will be shared.

9-12 Board Report - Erik Kravig

November 12, 2018 - 7:30 pm

First Quarter Perfect Attendance

35 Students achieved perfect attendance for the first quarter and were treated to breakfast at Three C's on Wednesday, November 7th.



Boone Central Cardinals @BC_Cardinals · Nov 7

Outstanding group of students who achieved perfect attendance for the first quarter enjoying breakfast at 3 C's. #BCCards



County Government Day - November 14th

BCHS junior class took will take part in the long-standing annual tradition of County Government Day, put on by the American Legion. Joined by students from Riverside and St. Edward, Boone Central juniors will spend the morning listening, learning and asking questions of the different county officials.

College Visits - Nov 27th, 29th

All 9th (Nov 27th) and 10th grade (Nov 29th) students will once again attend our annual college visits at UNL and UNK/CCC this fall. The goal of these visits is to expose students to the

different types of colleges and universities offered in Nebraska.

Veteran's Day - Nov 12th

The annual Veteran's Day program was held Monday, November 12th in the high school PA gym. Blake Trombley was the keynote speaker, Trey Zoucha and Katie Goodwater spoke as Girls/Boys State Representatives. Stephanie Wright was selected as the Voice of Democracy Winner.





Kallhoff Electric LLC

P.O. Box 113
Elgin, NE 68636
402-843-8433

ESTIMATE

Project	Date	Number
FLAG LIGHTS	10/3/2018	128

Name / Address
Boone Central Schools 605 South 6th Street Albion, NE 68620

*Alternate
Flag Lights*

Qty.	Description	Rate	Total
1	LABOR	1,000.00	1,000.00
1	LIFT RENTAL	150.00	150.00
1	DUSK TO DAWN PHOTOEYE	38.57	38.57
2	RAB LED FLAG LIGHT	341.25	682.50
3	1 GANG 1/2" 3 HOLE DEEP WP BOX	10.48	31.44
2	SINGLE GANG WEATHERPROOF COVER	1.35	2.70
3	4" SQUARE 2-1/8" DEEP JUNCTION BOX	1.82	5.46
3	4" SQUARE BLANK COVER	0.52667	1.58
20	1/2" EMT CONDUIT	0.61	12.20
100	#12 AWG SOLID THHN COPPER WIRE	0.19	19.00
20	MISCELLANEOUS SUPPLIES	1.00	20.00

We appreciate your business!		Subtotal	\$1,963.45
		Sales Tax (0.0%)	\$0.00
		Total	\$1,963.45

HBLED13A**RAB** Outdoor

Color: Bronze

Weight: 4.3 lbs

Project:

Type:

Prepared By:

Date:

Driver Info

Type	Constant Current
120V	0.12A
208V	0.09A
240V	0.08A
277V	0.07A
Input Watts	14W
Efficiency	92%

LED Info

Watts	13W
Color Temp	5000K (Cool)
Color Accuracy	67 CRI
L70 Lifespan	100000
Lumens	1490
Efficacy	105 LPW

Technical Specifications**Listings****UL Listing:**

Suitable for wet locations. Suitable for ground mounting.

IESNA LM-79 & IESNA LM-80 Testing:

RAB LED luminaires and LED components have been tested by an independent laboratory in accordance with IESNA LM-79 and LM-80.

LED Characteristics**Lifespan:**

100,000-hour LED lifespan based on IES LM-80 results and TM-21 calculations.

Lumen Maintenance:

The LED will deliver 70% of its initial lumens at 100,000 hours of operation.

Color Consistency:

7-step MacAdam Ellipse binning to achieve consistent fixture-to-fixture color.

Color Stability:

LED color temperature is warranted to shift no more than 200K in CCT over a 5 year period.

Color Uniformity:

RAB's range of CCT (Correlated Color Temperature) follows the guidelines of the American National Standard for Specifications for the Chromaticity of Solid State Lighting (SSL) Products, ANSI C78.377-2017.

Construction**Swivels:**

Fully adjustable with sure-grip locks. 1/2" NPS threaded arm with serrated locking swivel fits all standard mounting covers. Color matched EZ Grip lock nuts. Stainless steel screw.

Housing:

Precision die cast aluminum housing.

Gaskets:

High Temperature Silicone.

Finish:

Formulated for high-durability and long lasting color.

Green Technology:

Mercury and UV-free. RoHS compliant components.

Cold Weather Starting:

Minimum starting temperature is -40°C (-40°F).

Maximum Ambient Temperature:

Suitable for use in 40°C (104°F) ambient temperatures.

LFLOOD 13W:

LED Floodlight that reduces energy consumption by 85% compared to 100W PAR38. Spot and Flood beam patterns. Recommended for Residential and Commercial applications.

Electrical**THD:**

10% at 120V.

Power Factor:

98.6% at 120V.

Driver:

Multi-chip 13W high output long life LED Driver. Constant Current, 100V - 277V, 50/60 Hz.

Surge Protection:

4kV.

Other**Warranty:**

RAB warrants that our LED products will be free from defects in materials and workmanship for a period of five (5) years from the date of delivery to the end user, including coverage of light output, color stability, driver performance and fixture finish. RAB's warranty is subject to all terms and conditions found at

Patents:

LFLOOD thermal Management technology is protected under utility patents pending in the U.S., Canada and China.

Equivalency:

Equivalent to 100W PAR Halogen.

Buy American Act Compliance:

RAB values USA manufacturing! Upon request, RAB may be able to manufacture this product to be compliant with the Buy American Act (BAA). Please contact customer service to request a quote for the product to be made BAA compliant.

Optical**Reflectors:**

NEMA 5x5 floodlight reflector. Photometrics show flood configuration.

Need help? Tech help line (888) RAB-1000 Email sales@rablighting.com Website www.rablighting.com
Copyright © 2018 RAB Lighting Inc. All Rights Reserved. Note: Specifications are subject to change at any time without notice

HBLED13A

RAB Outdoor

Dimensions

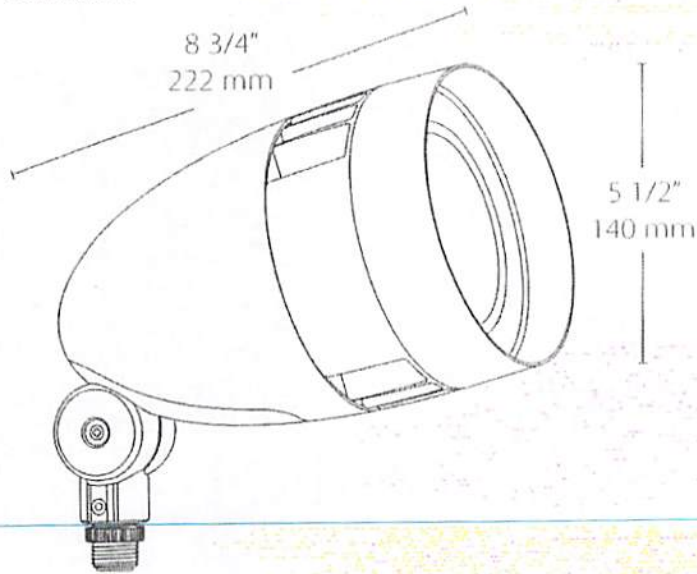

Features

- 80% energy savings vs. PAR floods
- Mount on junction box or on RAB Mighty Post
- Patent-pending Air-Flow technology
- 5-year warranty

Ordering Matrix

Family	Wattage	Color Temp	Finish	Driver Options	Other Options
HBLED	13	^	A	^	
	26 = 26W 18 = 18W	Blank = 5000K (Cool) N = 4000K (Neutral) Y = 3000K (Warm)	A = Bronze W = White B = Black VG = Verde Green	Blank = No Option /D10 = 0-10V Dimming /480 = 480V (Only available for 26W)	Blank = Standard USA = BAA Compliant

Need help? Tech help line (888) RAB-1000 Email sales@rablighting.com Website www.rablighting.com
Copyright © 2018 RAB Lighting Inc. All Rights Reserved. Note: Specifications are subject to change at any time without notice.

	Estimate	Actual Cost	Contractor/Supplier	Scope/Description
<u>Greenhouse Structure</u>	\$52,000	\$52,000	Stuppy	30' x 60' Greenhouse Materials
<u>Benches</u>	\$5,150	\$5,150	Stuppy	Mor-Space Benches (12) 5' x 12'
<u>Interior Shade System</u>	\$6,250	\$6,250	Stuppy	Motorized shade/energy retention system
<u>Irrigation System</u>	\$1,650	\$1,650	Stuppy	Irrigation over benches, includes fertilizer injector & progation bench control. (1) 6-zone Irrigation system.
<u>Concrete Footings</u>	\$10,323	\$10,323	Dugan	Treated frost footing/piers/columns
<u>Building Erection</u>	\$35,640	\$35,640	Dugan	Labor
<u>Irrigation System</u>	\$1,750	\$1,750	Dugan	Install Irrigation System
<u>Water Service/Meter</u>	\$5,500	\$442	City of Albion	Meter
		\$5,151	Dugan	Plumbing Connections and Materials for Water Service
<u>Water/Sewer</u>	\$9,500	\$12,581	Dugan	Connections to City Water and Sewer
<u>Concrete</u>	\$6,090	\$6,090	Dugan	Concrete Pads/Sidewalks at Exterior Doors
<u>Concrete Floor</u>	\$8,730	\$8,730	Dugan	Concrete Floor in Building
<u>Ewewash Station</u>	\$850	\$850	Dugan	Plumbing and Sink Install
<u>Electrical Service</u>	\$8,000	\$9,540	Dugan	Installation and Balance
<u>HVAC/Install</u>	\$1,500	\$1,500	Dugan	Gas Furnace and Gas Line Connections
<u>Rough in</u>	\$0	\$3,000	Dugan	Water, Sewer, Electrical
<u>Sod/Landscaping</u>	\$2,500	\$1,820	Nemaha	Sod around greenhouse
<u>Concrete/Drain System</u>	\$0	\$9,010	Dugan	Concrete drain system installed from sw corner of wrestling room around the south between the school and greenhouse
<u>Concrete</u>	\$0	\$8,350	Dugan	Replace existing driveway east of greenhouse; new parking, curb, and sidewalk
<u>Ballards</u>	\$0	\$700	Dugan	Install ballards around greenhouse
	\$155,433	\$180,527		

Stuppy Total	\$65,050
Dugan Total	\$113,215
City Total	\$442

Nemaha Total	\$1,820
	<u>\$180,527</u>

Revenue	
WindFarm Grant	\$23,320
AEF Foundation	\$150,000
BCSBuilding Fund	\$7,207
	<u>\$180,527</u>

APPLICATION AND CERTIFICATE FOR PAYMENT

AIA DOCUMENT G702

PAGE ONE OF ONE PAGES

TO (Owner): Boone Central Schools
 Att: Nicole Hardwick
 PO Box 391
 Albion, NE 68620

PROJECT: Boone Central High School
 Greenhouse

CONTRACT FOR: Greenhouse Materials

PRIME CONTRACT NO.:

CONT: Stuppy, Inc
 Accts Payable: Kathy Blackwell
 1212 Clay St
 North Kansas City, MO 64116

APPLICATION : 1

PERIOD FROM : 2/1/18
 TO : 2/28/18

ARCHITECT'S:
 PROJECT NO :

CONTRACT DATE : 12/12/2017

Distribution to :

OWNER
 ARCHITECT
 CONTRACTOR

CONTRACTOR'S APPLICATION FOR PAYMENT

The present status of the account for this contract is as follows:

CHANGE ORDER SUMMARY			ADDITIONS	DEDUCTIONS
Change Orders approved in previous months by Owner				
TOTAL				
APPROVED THIS MONTH				
Number	Date Approved			
TOTALS		\$0.00		\$0.00
Net change by Change Orders				\$0.00

ORIGINAL CONTRACT SUM \$ 65,050.00

Net change by Change Orders \$ 0.00

CONTRACT SUM TO DATE \$ 65,050.00

TOTAL COMPLETED & STORED TO DATE \$ 65,050.00
 (Column G on G703)

RETAINAGE 0% \$ 0.00
 or total in Column I on G703

TOTAL EARNED LESS RETAINAGE \$ 65,050.00

LESS PREVIOUS CERTIFICATES FOR PAYMENT \$ _____

CURRENT PAYMENT DUE \$ 65,050.00

The undersigned Contractor certifies that to the best of his knowledge, information and belief the Work covered by this Application for Payment has been completed in accordance with the contract documents, that all amounts have been paid him for Work for which previous Certificates for Payment were issued and payments received from the Owner, and that the current payment shown herein is now due

CONTRACTOR: STUPPY, INC.

By: *Alma M. Kelly* Date: 2/19/18

State of: MISSOURI County of: CLAY

Subscribed and sworn to me before this 19th day of February 2018

Notary Public: *Kathy L Blackwell*

My Commission expires: 11-15-19

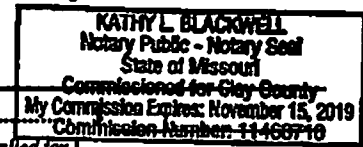

ARCHITECT'S CERTIFICATE FOR PAYMENT

In accordance with the Contract Documents, based on on-site observations and the data comprising the above application, the Architect certifies to the Owner that the work has progressed to the point indicated; that to the best of his knowledge, information and belief, the quality of the work is in accordance with the Contract Documents; and that the Contractor is entitled to payment of the AMOUNT CERTIFIED

AMOUNT CERTIFIED
 (Attach explanation if amount certified differs from the amount applied for.)

ARCHITECT:

By: _____ Date: _____

This Certificate is not negotiable. The AMOUNT CERTIFIED is payable only to the Contractor named herein. Issuance, payment and acceptance of payment are without prejudice to any rights of the Owner or Contractor under this Contract



Dugan Builders LLC

118 West Adams Street
O'Neill, NE 68763
(402) 992-0894
email - Dugan.buildersllc@gmail.com

Billing Statement

Date: 6/10/2018

To: Boone Central Public Schools
Nicole Hardwick
Albion, NE 68620

Jobsite Address: BCHS
Boone Central High School
605 S 6th St
Albion, NE 68620

Construct Greenhouse per plans

Building Frost footings piers with column treat	\$10,323.00
Water Service rough in	\$1,000.00
Sewer service rough in	\$1,000.00
Electrical service rough in	\$1,000.00
Concrete floor in building	\$8,730.00
concrete pads and walks outside building	\$4,000.00
Additional concrete and drain system between school and green house	\$7,410.00



Total \$33,463.00

Thank you and we appreciate your business.

Dugan Builders LLC
ONeill NE 68763
(402) 992 0894



Dugan Builders LLC

118 West Adams Street
O'Neill, NE 68763
(402) 992-0894
email - Dugan.buildersllc@gmail.com

Billing Statement

Date: 7/13/2018

To: Boone Central Public Schools
Nicole Hardwick
Albion, NE 68620

Jobsite Address: BCBS
Boone Central High School
605 S 6th St
Albion, NE 68620

Construct Greenhouse per plans

Building Erection Progress	\$17,820.00
----------------------------	-------------



Total \$17,820.00

Thank you and we appreciate your business.

Dugan Builders LLC
ONeill NE 68763
(402) 992 0894



Dugan Builders LLC

118 West Adams Street
O'Neill, NE 68763
(402) 992-0894
email - Dugan.buildersllc@gmail.com

Billing Statement

Date: 8/10/2018

To: Boone Central Public Schools
Nicole Hardwick
Albion, NE 68620

Jobsite Address: BCHS
Boone Central High School
605 S 6th St
Albion, NE 68620

Construct Greenhouse per plans

Building Erection Complete	Second Half	\$17,820.00
Irrigation system installation		\$1,750.00



Total \$19,570.00

Thank you and we appreciate your business.

Dugan Builders LLC
ONeill NE 68763
(402) 992 0894



Dugan Builders LLC

118 West Adams Street
O'Neill, NE 68763
(402) 992-0894
email - Dugan.buildersllc@gmail.com

Billing Statement

Date: 9/24/2018

To: Boone Central Public Schools
Nicole Hardwick
Albion, NE 68620

Jobsite Address: BCHS
Boone Central High School
605 S 6th St
Albion, NE 68620

Construct Greenhouse per plans

Plumbing connections and materials in building	\$5,151.09
Water and sewer connections to city lines	\$12,581.00
Concrete pads and sidewalks at ext. doors	\$2,090.00
Sink and Eyewash station	\$850.00
Electrical installation Balance	\$9,539.78
HVAC/ install gas furnaces and int. gas line	\$1,500.00
Concrete Drainage swale west of wrestling room	\$1,600.00
Removal of sidewalk and driveway east of greenhouse	\$3,250.00
Install concrete in parking with curb and sidewalk back	\$5,100.00
Install balllards with concrete at electrical transformer	\$700.00

Total \$42,361.87



Thank you and we appreciate your business.

Dugan Builders LLC
ONeill NE 68763
(402) 992 0894

City of Albion
 420 West Market Street
 Albion, NE 68620

Invoice

Date
9/6/2018

Bill To

Invoice #
8005

Boone Central Schools
 P.O. BOX 391
 ALBION, NE 68620

Terms
Net 30

Item	Description	Qty	Rate	Amount
Parts	1" water meter	1	384.23	384.23T
Parts	1" 90 degree water meter spuds	2	28.96	57.92T
	water meter for Greenhouse Exempt from sales tax		0.00%	0.00
		<i>Greenhouse - Act</i>		
		<i>05 2190 610 06 / 0197</i>		<i>2 000</i>
Total				\$442.15

Please Make checks payable to City of Albion.
 Call the City Offices at 395-2428 with any questions regarding this invoice.
 Thank You.

School Meal Accounts

Student meal accounts, regardless of meal status, are not intended to be used as a charge account. Each family has one account that is linked to all their students. Parents are expected to pre-pay money into their family account to cover the cost of meals and milk. Parents can access their family account information using the WordWare Parent Portal (<https://family.wordwareinc.com/>) or by contacting the school directly. Payments can be made within WordWare using eFunds or by sending a check or cash to school

“Low Balance” reminders will be sent out to parents if their account falls below \$20.00 to allow time to deposit additional funds before the account becomes negative. If an account falls below -\$20.00 parents will be notified and students will be asked to bring a sack lunch from home until the negative balances have been taken care of or a payment plan has been arranged. If a parent stops making payments per the agreement, students will be asked to bring a sack lunch until the balance is paid in full.

Meal funds will carry over from month to month. At the end of the school year any balance remaining will carry over into the next school year. If a family is planning to leave the district or any remaining children will be graduating, the District shall return any funds remaining in the meal account.

Students will not be allowed to purchase seconds or additional a la carte items unless they have a positive lunch balance. A la carte milk is the only exception for students who bring a sack lunch to school if funds are brought to school to cover the cost of the milk (no additional charges will be made to the account).

Negative balances must be paid in full before the end of the school year. Report cards will not be released at the end of the year until accounts are paid in full. Graduating students will not receive their diploma until accounts are paid in full.

Any unpaid meal charges will be carried over at the end of the school year as a delinquent debt and the District shall undertake reasonable collection efforts to collect unpaid meal charges classified as delinquent debt, pursuant to and in compliance with state and federal law. The District shall maintain records of its collection efforts and, once delinquent meal charges are converted to bad debt, its documentation establishing and handling of the bad debt.

Free or Reduced-Priced School Meals

It is the policy of the District to comply with the National School Lunch Program and School Breakfast Program and all other federal grant programs that provide free or reduced meals to qualifying students.

Student Eligibility

Families of students who may be eligible for free or reduced-price school meals should submit an application to determine their eligibility. Applications are available through the Superintendent or Superintendent’s designee. As long as an application is submitted on or after July 1, the application will be considered current for the new school year. A student may become eligible for free or reduced meals at any time during the school year if the household experiences a change in financial circumstances.

Meal Accounts:

- The District will ensure that families can check their meal account balances in a manner other than exclusively online.
- The District will ensure that at least one form of meal account payment is free of charge.
- The District will encourage families to pre-pay without charge for free or reduced-priced meals.
- The District will allow students/families to add funds during the school day.
- Balances will carry over from month to month.
- A family may request that the remaining balance be returned to them at the end of the school year (otherwise funds will carry over into the next school year).
- Funds will be returned to families leaving the school district or if student graduates.

Student Confidentiality

The District will disclose individual student eligibility information only to those persons (and organizations) who require the information in order to carry out an activity specifically authorized by the National School Lunch Act, subject to applicable legal exceptions.

The District shall not use or implement any colored or coded meal cards, tickets, tokens, or other methods of payment that would overtly identify a student as being eligible for free or reduced-price meals.

Distribution Annually

This policy shall be provided in writing to all students' households at the start of each school year and to households transferring to the District during the school year.

This policy shall also be provided annually to District staff members responsible for the enforcement of this policy, including food service professionals.

The Superintendent or the Superintendent's designee shall maintain documentation of the annual distribution of this policy to students' households and District staff.

Legal Reference: Richard B. Russell National School Lunch Act (42 U.S.C. § 1751); U.S.D.A. Memorandum SP 57-2016.

Date of Adoption: June 28, 2017

Revised on: November 12, 2018

The board of education finds that the possession of illegal drugs and other contraband on school grounds is unlawful, is disruptive of the educational process, is harmful to students and staff, and is contrary to the interests of the school district. Accordingly, to minimize the presence of these items on school grounds, the administration is authorized to use drug detection dogs according to the protocol set forth in this policy.

Protocol for Use of Drug Detection Dogs

1. The superintendent, or the building principal with the superintendent's permission, may initiate the use of specially trained drug dogs to conduct an inspection.
2. The administration will contact the canine provider and/or the appropriate law enforcement agency to schedule the use of a drug dog or dogs. The administration shall require an assurance from the provider that any drug dogs to be used in the school have been properly trained, and may request evidence of the training and/or certification of the dogs. In no event will the school district authorize a drug dog to sniff any person.
3. The superintendent or if designated by the superintendent, the building principal, and law enforcement representatives or canine provider will confer regarding the specific plan of areas to be inspected. The plan may involve any or all school building facilities, vehicles in the school parking lot, or other areas where student and staff vehicles are parked on school property during or after school hours.
4. If the inspection is scheduled for a day when school is in session, students and staff will be informed over the public address system, and will be directed to remain in their rooms until given further directions.
5. During the inspection, administrators may assign personnel to designated areas as deemed appropriate to assist in the smooth handling of the inspection.
6. After the inspection is finished, students and staff will be notified over the public address system, and will be thanked for their cooperation.
7. If the drug dog alerts, the alert will constitute reasonable cause for the administration to conduct a search of the property. If the drug dog alerts on a vehicle on school grounds, the owner will be required to unlock the vehicle doors and trunk for further inspection of the interior of the vehicle. If the owner refuses to unlock the vehicle, the matter will be turned over to law enforcement authorities. The owner will be subject to disciplinary action as specified in board policy and/or the student or staff handbook or as otherwise allowed by law. This may include discipline for the refusal to obey an administrative directive.
8. Any illegal drugs or contraband found on school grounds, whether in a desk, locker, vehicle, or any other place on school grounds, will be confiscated and turned over to law enforcement authorities. A student's parents will be contacted. The individual will be subject to disciplinary

action as specified in board policy and/or the student or staff handbook or as otherwise allowed by law.

9. At the conclusion of the inspection, school officials will confer with the canine provider and/or any law enforcement authorities who were involved in the inspection to review the results of the inspection. The administration may authorize any follow-up inspections or other action deemed appropriate.

NOTICE TO STUDENTS AND STAFF

Students and staff shall be informed of the District's policy regarding the use of drug detection dogs as soon as practicable after the adoption of this policy. Thereafter, students and staff shall be informed of the policy at the beginning of the school year. By this policy and/or via the provision in the student or staff handbook, students and staff are specifically notified that:

1. Lockers may be sniffed by drug dogs at any time.
2. Vehicles parked on school property may be sniffed by drug dogs at any time.
3. Classrooms and other common areas may be sniffed by drug dogs at any time students and staff are not present.
4. If contraband of any kind is found, the student or staff member shall be subject to appropriate disciplinary action.

Adopted on: November 12, 2018

Social media is an important tool for communicating, keeping up-to-date with current developments in education, and for conducting research to enhance management, teaching, and learning skills. The district also uses social media accounts to provide information to district stakeholders. This policy is intended to ensure (1) appropriate use of social media by staff and (2) appropriate control of social media accounts belonging to or affiliated with the district. Staff should also refer to the district's policy on Staff Computer and Internet Usage.

I. Personal Versus School-Affiliated Social Media Use

A. Personal Social Media Use

1. The school district will not require staff members or applicants for employment to provide the district with their username and password to personal social media accounts.
2. The district will not require staff to add anyone to the list of contacts associated with the staff member's personal social media accounts or require a staff member to change the settings on his or her personal social media accounts so that others can or cannot view their accounts.
3. Staff members whose personal social media use interferes with the orderly operation of the school or who use social media in ways that are not protected by the First Amendment may be subject to discipline by the district.
4. Staff members who wish to begin using or to continue using the school district name, programs, mascot, image or likeness as part of any social media profile must notify their supervising administrator of the use, and must secure the administrator's permission to do so.

B. School-Affiliated Social Media Use

1. Any social media account which purports to be "the official" account of the school district (e.g., "Cardinal Wrestling"), or any of its programs, classes or entities will be considered to be an account that is used exclusively for the school district's business purpose. Staff members may not use "official" accounts for personal use.
2. Staff may be required to provide their supervising administrator with the username and password to school-affiliated social media accounts.

3. Staff may be required to interact with specified individuals on school-affiliated social media accounts.
4. When staff use school-affiliated social media accounts to comment on school-related matters, they do not do so as private citizens and are therefore not entitled to First Amendment protections.

II. Staff Expectations in Use of Social Media – Applicable to Both Personal and School-Affiliated Use

A. General Use and Conditions

Staff must comply with all board policies, contract provisions, and applicable rules of professional conduct in their social media usage. They must comply with the board's policy on professional boundaries between staff and students at all times and in both physical and digital environments.

Staff must obtain the consent of their building principal or the superintendent prior to posting any student-related information in order to make sure that the publication does not violate the Federal Education Records Privacy Act or any other laws. Staff must also comply with all applicable state and federal record retention requirements, even with regard to personal social media usage.

Staff must comply with all applicable laws prohibiting the use or disclosure of impermissible content, such as copyright laws, accountability and disclosure laws, and any other law governing the use of resources of a political subdivision. Questions about appropriate content should be referred to the staff member's supervising administrator.

B. Acceptable Use

1. Staff may use social media for instructional purposes.
2. Staff may use social media for school-related communication with fellow educators, students, parents, and patrons.
3. Teachers should integrate the use of electronic resources, which may include social media, into the classroom. As the quality and integrity of content on social media is not guaranteed, teachers must examine the source of the information and provide guidance to students on evaluating the quality of information they may encounter.

C. Unacceptable Use

1. Staff shall not access obscene or pornographic material while at school, on school-owned device or on school-affiliated social media accounts.

2. Staff shall not engage in any illegal activities, including the downloading and reproduction of copyrighted materials.
3. Staff shall not access social media networking sites such as Facebook, Twitter, and Instagram on school-owned devices or during school time unless such access is for an educational activity which has been preapproved by the staff member's immediate supervisor. This prohibition extends to using chat rooms, message boards, or instant messaging in social media applications and includes posting on social networking sites using personal electronic devices.

III. School-Affiliated Digital Content

A. General Use and Conditions for School-Affiliated Accounts

Staff must obtain the permission of their supervising administration prior to creating, publishing, or using any school-affiliated web pages, microblogs, social media pages or handles, or any other digital content which represents itself to be school-related, or which could be reasonably understood to be school-related. This includes any content which identifies the school district by name in the account name or which uses the school's mascot name or image.

Staff must provide administrators with the username and password for all school-affiliated accounts and must only publish content appropriate for the school setting. Staff may not provide the username and password to school-affiliated accounts to any unauthorized individual, including students and volunteers.

B. Moderation of Third-Party Content

The purpose of school-related social media accounts is to disseminate information. No school-related or school-affiliated social media account covered by this policy shall permit comments by the public unless otherwise approved by the superintendent. All comment functions for applications such as Facebook and Instagram must be turned to "off" without this approval.

In the event the superintendent permits content created by anyone other than the administrator of the account to appear on the account's pages, such as comments made by students, parents, and patrons, the account administrator must monitor the content to ensure it complies with this policy. Posts, comments, or any other content made on the account's pages may be removed when the content meets any of the following conditions:

1. Is obscene, lewd, or appeals to prurient interests;
2. Contains information relating to a student matter or personnel matter which is protected under or prohibited by state or federal law;
3. Contains threatening, harassing, or discriminatory words or phrases;

4. Incites or is reasonably anticipated to incite violence, illegal activity, or a material and substantial disruption to school operations or activities;
or
5. Contains any other threat to the safety of students and staff.

Every account administrator must keep a copy of any removed content and must provide a copy to the superintendent along with written notification for the reason the post has been removed. All questions about the appropriateness of removal must be directed to the superintendent.

Reference: KSB 4051

Adopted on: November 12, 2018

Minimum Age:

A child shall be eligible for admission into kindergarten at the beginning of the school year if the child is five years of age or will be five years of age on or before July 31 of the calendar year in which the school year for which the child is seeking admission begins. The School Board shall admit a child who will reach the age of five years on or after August 1 and on or before October 15 of such school year if the parent or guardian requests such entrance and provides an affidavit stating that:

- the child attended kindergarten in another jurisdiction in the current school year;
- the family anticipates a relocation to another jurisdiction that would allow admission within the current year; or
- the child is capable of carrying the work of kindergarten which can be demonstrated through a recognized assessment procedure approved by the Board.

Early Admission to Kindergarten:

The following assessment procedure for determining if a child is capable of carrying the work of kindergarten is approved and shall be made available to interested persons:

Early kindergarten enrollment exceptions may be made for younger children who are intellectually advanced. At a minimum, eligibility for the admission shall be based upon an analysis of the child's: (1) mental ability, (2) emotional/social development, (3) pre-academic skills, and (4) fine motor skills.

The kindergarten early entrance assessment procedures are designed to identify and place in kindergarten those children who:

- a. will turn 5 years of age between August 1 and October 15;
- b. are deemed by parents or guardians as being intellectually advanced and likely to benefit from advanced grade placement; and
- c. can demonstrate through recognized assessment procedures approved by the board that the child is capable of performing the work of kindergarten.

The recognized assessment approved by the board is the *Development Test of Kindergarten Readiness – Second Edition (DTKR-II)* by ProEd Kindergarten Readiness Test (KRT) by Scholastics.

In the discretion of the Superintendent or designee, the assessments may be administered by the School District's professional staff, or the parents or guardians may be required, at their own expense, to have all or some of the required assessments completed by reputable professionals and to submit the results of such assessments to the School District.

The decision regarding early entrance to kindergarten requires careful consideration of all factors that affect kindergarten success with final determination to be made based on the recommendation of the District Evaluation Team, to be composed of such individuals as the Superintendent or designee determine appropriate. The academic, social, and emotional readiness, as well as the student's physical development and well-being, must be weighed with institutional factors also considered. Sound decision making in the area of early entrance to kindergarten is dependent upon reliable information regarding a student's readiness and a thoughtful balancing of the myriad of factors implicated by the decision.

Parents will be notified in writing of the results of the Early Kindergarten Entrance assessment and the determination of the District Evaluation Team in a timely fashion; not to exceed three weeks after the assessments are completed.

Families who seek early admission of their child into kindergarten must obtain an *Early Entrance to Kindergarten Packet* from the School District Administration.

Parents must fill out the early entrance application forms, which include a parent questionnaire and obtain and attach a reference letter from someone who is well acquainted with the child but not a relative of the child. The person providing this reference should know the child well enough that they can speak with some expertise about the child's attributes and abilities. The reference letter should indicate whether this person recommends the child be schooled with children who will be a year older than the child and, if so, the evidence this person has concerning the child's mental ability, fine and gross motor ability, visual and auditory discrimination, emotional/social development, and communication skills. Suggestions for this reference letter are a preschool teacher, a Sunday school teacher, a day-care provider, or a physician.

The assessment request, reference letter and parent questionnaire must be completed and returned to the District no later than May 25th of the spring before fall enrollment to allow summer assessment to be completed.

Decisions regarding early kindergarten entrance must include consideration of the above and shall not be made based on race, color, gender, religion, ancestry, national origin, marital status, age, disability, or sexual orientation of the child or the child's parents or guardians. Institutional factors, such as capacity, may also be considered.

Admission to First Grade:

A child may be eligible to enter first grade, even if the child has not attended kindergarten, if the child is six years of age or will be six years of age on or before October 15 of the current school year and school officials determine that first grade is the appropriate placement for the child.

Graduates:

A student who has received a high school diploma or received a General Equivalency Diploma shall not be eligible for admission or continued enrollment.

Age 21:

A student shall not be admitted or continued in enrollment after the end of the school year in which the student reaches the age of 21. The school year for this purpose ends at the last day of instruction for graduating seniors.

Birth Certificate

A certified copy of the student's birth certificate issued by the state in which the child was born, upon admission of a child for the first time, shall be provided within 30 days of enrollment. Other reliable proof of the child's identity and age, accompanied by an affidavit explaining the inability to produce a copy of the birth certificate, may be used in lieu of a birth certificate. An affidavit is defined as a notarized statement by an individual who can verify the reason a copy of the birth certificate cannot be produced. (Failure to provide the birth certificate does not result in non-enrollment or disenrollment, but does result in a referral to local law enforcement for investigation).

A student who fails to meet the foregoing requirements shall not be permitted to enroll or to enter school, or if provisionally enrolled or enrolled without compliance, shall not be permitted to continue in school until evidence of compliance or an exemption from compliance is given.

Reference: Perry 5001

Date of Adoption: July 16, 2015

Revised on: August 14, 2017

Revised on: November 12, 2018

Enrollment Requirements:

- Each student wishing to enroll in the school district must be immunized as required by state law and the rules and regulations promulgated by the Nebraska Department of Health and Human Services in effect at the time of the student's enrollment.
- The district is not responsible for the cost of such immunizations.
- Any student who does not comply with this policy shall not be permitted to continue attending school.
- The building principal shall be responsible for maintaining immunization records for the students enrolled in his/her building and shall share that information with the school's threat assessment and crisis teams as appropriate.

Exceptions:

1. Provisional Enrollment
 - a. Students who meet the statutory requirements for provisional enrollment may be allowed to attend school for sixty days without the necessary immunizations.
2. Immunization shall not be required if the student's parent or guardian submits one of the following to the superintendent of schools:
 - a. A statement signed by a medical professional stating that the required immunization would be injurious to the health and well-being of the student or any member of the student's household;
or
 - b. An affidavit signed by the student or a legally authorized representative of the student, stating that the immunization conflicts with the student's sincerely held religious beliefs.
3. Students who are excepted from the immunization requirement may be excluded from school in the event of an outbreak of any contagious disease in the school population.

Date of Adoption: July 20, 2015
Revised on: November 12, 2018

Students must be enrolled at Boone Central School on a full-time basis. Full-time basis is defined as attending classes for the full instructional day within the public-school system.

Exceptions

A student may be permitted to enroll on a part-time basis pursuant to applicable regulations when enrollment is appropriate for reasons that include but are not limited to the following:

- the student attends another education institution on a part-time basis;
- has a modified schedule because of a disability or as part of an individualized education plan;
- or is a student who resides in the school district but attends a private, denominational, or parochial school or a school that elects not to meet accreditation or approval requirements (referred to herein as an exempt school student or an exempt school, respectively).

Exempt School Student Application for Part-Time Enrollment

The parent or guardian of an exempt school student who is of appropriate age to attend school, resides in the school district, has not graduated from high school, and has not received a graduate equivalency diploma must meet all of the district's admission and registration requirements and file an application for enrollment on forms provided by the school district prior to the start of the semester for which the student wishes to enroll. For students who move into the district mid-semester, the application and registration process must be completed within 20 days of moving into the district.

The administration shall review the application, determine whether to approve or deny it, notify the parent or guardian, and schedule enrollment at an educationally appropriate time in the building or attendance center of the administration's choice. Enrollment does not carry over from one year to the next, and the parent or guardian of an exempt school student must apply for enrollment each school year.

Capacity

The enrollment of exempt school students is subject to the capacity limitations established by the district for grades, classes, courses, and programs. Full-time students shall be given priority for enrollment in grades, classes, courses, and programs. Capacity limitations are included in Option Enrollment Policy.

Placement of Students

Exempt school students shall be placed in courses for which they have adequate preparation and which are determined to be educationally appropriate based on criteria that include, but are not limited to the student's age, achievement test scores, academic record, evaluation by school personnel and any other standards used by the district for the placement of students.

Grades, Graduation, and Academic Honors

Part time and exempt school students shall receive grades, report cards, and transcripts, but shall not be eligible to graduate, receive a diploma or qualify for class ranking unless they meet all district requirements for such including earning a sufficient number of credit hours and semesters of attendance.

Applicability of School Rules

Exempt school students are subject to all rules and regulations of the board of education and administration as set forth in policy, handbooks or other communications, as well as the rules and directives of the building administration and teaching personnel. They must remain on the school campus during scheduled classes but must leave the school campus when not engaged in a course or course-related activity unless the course or course-activity requires their presence or the building principal approves their presence. Students who violate school policies, rules, or directives shall be subject to disciplinary procedures up to and including suspension and expulsion.

Extracurricular Sports and Activities

The following NSAA guidelines shall apply in determining the eligibility for a student who has previously attended an exempt school and transfers to become a bona fide student:

- The exempt school, which the student previously attended, must have received acknowledgement from the Nebraska Department of Education that the school conformed to the required statuses.
- The student must be placed in a grade level that will classify the individual student as a high school student (grade nine, ten, eleven, or twelve).
- The exempt school transfer student must be continuously enrolled in a minimum of ten (10) credit hours of instruction per semester at Boone Central for the student to compete.
- If the student has been promoted from the eighth grade at the exempt school and will be attending Boone Central for the first time as a ninth-grade student, he/she is automatically eligible. (This applies to students transferring from an exempt school located outside the School District and to students transferring from an exempt school located within the School District.)
- If the student is transferring from an exempt school and will be placed in the tenth, eleventh, or twelfth grade at Boone Central, he/she is considered a transfer student and shall be ineligible for varsity competition for ninety (90) school days unless the exempt school the student was previously is located within the Boone Central School District.
- Exempt school students entering Boone Central as a tenth, eleventh, or twelfth grade student must complete twenty (20) credit hours or must have received twenty (20) credit hours (entered on the records as partial fulfillment of the school's graduation requirement) for the immediate preceding semester to be eligible for varsity competition.
- Exempt school students shall be credited with the number of semesters of high school membership; students may not exceed eight semesters of school membership beginning with the initial enrollment in grade nine or the equivalent.

Transportation

Exempt school students are not entitled to transportation or reimbursement for transportation.

Adopted on: July 20, 2015

Revised on: November 12, 2018

The Boone Central Board of Education supports the concept embodied in the Enrollment Option Program that parents and legal guardians have the primary responsibility for insuring that their children receive the best education possible. Accordingly, the school district will participate in the option enrollment program and receive option students as provided herein.

Enrollment Option is available only once to each student prior to graduation except that an option does not count toward that limitation if it meets, or met at the time of the option one of the following criteria:

- a) The student relocated to a different resident school district,
- b) The option school district merges with another district,
- c) The option school district is a Class I district,
- d) The student will have completed either the grades offered in the school building originally attended in the option school district or the grades immediately preceding the lowest grade offered in the school building for which a new option is sought,
- e) The option would allow the student to continue current enrollment in a school district,
- f) The option would allow the student to enroll in a school district in which the student previously enrolled as a student, or
- g) The student is an open enrollment option student. 79-237-246 R.R.S.

Definitions

Option Student - Option student shall mean a nonresident student who has chosen to attend the school district under the provisions of the option enrollment program.

Resident School District - Resident school district shall mean the school district in which a student resides or in which the student is admitted as a resident of the school district pursuant to state law.

Option School District - Option school district shall mean the school district that a student chooses to attend other than his or her resident school district.

Persons Entitled to Apply for Option Enrollment of Students

Only parents and legal guardians may apply for option enrollment of students. Applications filed by foster parents and adults acting *in loco parentis* are not authorized and will be automatically denied.

Duties, Entitlements and Rights of Option Students

Except as otherwise provided herein, once an option student's option enrollment application has been accepted he/she shall be treated as a resident student of the school district.

Standards for Acceptance or Rejection of Option Students

- 1) An option enrollment application shall be rejected in the event the capacity of a program, class, grade level, or school building or the availability of appropriate special education programs operated by the School District would be exceeded by acceptance of the application, and an option enrollment application shall be rejected in the event the application is for enrollment in a program, class, grade level, or school

building which has been declared unavailable to option students due to lack of capacity. Numeric Capacity will be determined based upon available staff, facilities, projected enrollment of resident students, projected number of students with which the option school district will contract based on existing contractual arrangements, and availability of appropriate special education programs. Individuals seeking information about the numeric capacity set by the board may contact the superintendent for a copy of that resolution.

- 2) In addition to the numeric and programmatic capacity standards outlined above, the school district shall not accept an option student when acceptance of the student:
 - a) Would increase the operating costs of the school district, such as by requiring the hiring of new staff or contracting with outside entities to provide services to the student;
 - b) Would require the procurement of new equipment, technology, or furnishings;
 - c) Would cause or require the rearrangement of caseloads for staff and contracted professionals;
 - d) Is reasonably deemed by appropriate school staff to pose a potential risk to the health or safety of students or staff;
 - e) May pose a risk of adversely affecting the quality of educational services being provided to resident students, as determined by appropriate school staff.
- 3) The school district shall accept an option student with a disability only if the capacity limitations have not been met, and to the extent that the school district's then current staff and facilities are sufficient to accommodate the student's needs without significantly increasing the operating costs of the school district, such as by requiring the hiring of new staff.
- 4) The school district shall not base the decision to accept or reject an option student on the student's previous academic achievement, athletic or other extracurricular ability, disabling condition(s), proficiency in the English language, or previous disciplinary proceedings.
- 5) If there are more option student applicants for any program, class, grade level or school building than can be accepted into such program, class, grade level or school building, applicants shall be accepted in the following order:
 - a) Students with brothers or sisters attending the school district, either as resident students or as option students, shall be granted first priority;
 - b) Thereafter, option students shall be accepted into such program, class, grade level or school building in the order in which written applications were received by the school district.

False or Misleading Option Applications

If the school district discovers that a previously accepted option application contained false or substantively misleading information, the option application will be rejected.

Academic Credits and Graduation

The school district shall accept credits toward graduation that were awarded by another accredited school district, and shall award a diploma to an option student if the student meets the graduation requirements of the school district.

Information Regarding Schools, Programs, Policies and Procedures

The school district, its officers and employees, shall make information about the school district and its schools, programs, policies and procedures available to all interested people.

NSAA Eligibility

Potential applicants should consult with officials of the Nebraska School Activities Association (NSAA) to determine a student's eligibility for participation in extracurricular activities if a student is or may be participating in any activities sponsored by the NSAA.

Procedure for Students Optioning Into or Out of the School District

- 1) Between September 1 and March 15, the Application for Student Transfer – Nebraska Enrollment Option must be sent or delivered to the Office of the Superintendent of the Option School District.
 - a. If after March 15, the application must be accompanied by a written release from an authorized official of the Resident District or Section 2 of the application must be completed by the Resident District, unless the student relocated after February 1st.
- 2) On or before April 1st, the school district shall respond to the application. If the Option Enrollment Application is denied, the reason for denial will be stated in the appropriated place. A photocopy of the application will be sent to the Applicant and the Resident School District.

Late Applications and Requests for Release

A request for release may be refused if the application is submitted after March 15th under the following conditions:

- When the district has already entered into contracts with teaching staff for the following school year;
- When the district has already contracted for the performance of specific services for the student;
- When the release of the student would have a negative financial impact or loss of revenue for the district.

The board of education will approve late applications to option into the district under the following conditions:

- When the resident district has released the student;
- When the student's late enrollment into the district meets the standards for acceptance or rejection of option students contained elsewhere in this policy;

The superintendent will notify parents or guardians who have submitted properly completed option applications after March 15th no later than 60 days following submission of the application of the board's acceptance or rejection of the application.

Cancellation of Option

Students who option either into or out of the school district shall:

- 1) Attend the option school district until graduation or relocation/re-option in a different resident school district unless the student chooses to return to the resident school district, in which case the student's

parent or legal guardian shall timely submit a cancellation form to the school board or board of education of the option school district and the resident school district for approval for the following year.

- 2) Attend an option school district for not less than one school year unless the student relocates to a different resident school district, completes requirements for graduation prior to the end the school year, transfers to a parochial or private school, or upon mutual agreement of the resident and option school districts cancels the enrollment option and returns to the resident school district.

Authority of Superintendent

The Board of Education authorizes the superintendent of schools to make decisions on its behalf pursuant to and to apply the criteria articulated by this policy in determining whether to grant or deny option enrollment applications.

Legal Reference: Neb. Rev. Stat. §§ 79-232 to 79-246

Date of Adoption: July 20, 2015
Revised on: July 21, 2016
Revised on: November 12, 2018

Administrative and teaching personnel may take actions regarding student behavior, other than those specifically provided in this policy and the Student Discipline Act, which are reasonably necessary to aid the student, further school purposes, or prevent interference with the educational process. Such actions may include, but need not be limited to, counseling of students, parent conferences, rearrangement of schedules, requirements that a student remain in school after regular hours to do additional work, restriction of extracurricular activity, or requirements that a student receive counseling, psychological evaluation, or psychiatric evaluation upon the written consent of a parent or guardian to such counseling or evaluation. Disciplinary consequences may also include in-school suspension, Saturday School, and any other consequence authorized by law. District administrators may develop building-specific protocols for the imposition of student discipline.

In this policy, references to "Principal" shall include building principals, the principal's designee, or other appropriate school district administrators.

Any statement, notice, recommendation, determination, or similar action specified in this policy shall be effectively given at the time written evidence thereof is delivered personally to or upon receipt of certified or registered mail or upon actual knowledge by a student or his or her parent or guardian.

Any student who is suspended or expelled from school pursuant to this policy may not participate in any school activity during the duration of that exclusion including adjacent weekends. The student activity eligibility of a student who is mandatorily reassigned shall be determined on a case-by-case basis by the principal of the building to which the student is reassigned.

Short-Term Suspension

The Principal may exclude students from school or any school function for a period of up to five school days (short-term suspension) on the following grounds:

1. Conduct constituting grounds for expulsion as hereinafter set forth; or,
2. Other violations of rules and standards of behavior adopted by the Board of Education or the administrative or teaching staff of the school, that occur on or off school grounds, if such conduct interferes with school purposes or there is a connection between such conduct and school.

The following process applies to short-term suspension:

1. The Principal shall make a reasonable investigation of the facts and circumstances. Short-term suspension shall be imposed only after a determination that the suspension is necessary to help any student, to further school purposes, or to prevent an interference with school purposes.
2. Prior to commencement of the short-term suspension, the student will be given oral or written notice of the charges against the student. The student will be advised of what he or she is accused of having

done, be given an explanation of the evidence the authorities have, and be given an opportunity to explain the student's version of the facts.

3. Within 24 hours or such additional time as is reasonably necessary following the suspension, the Principal will send a written statement to the student, and the student's parent or guardian, describing the student's conduct, misconduct or violation of the rule or standard and the reasons for the action taken. An opportunity will be given to the student, and the student's parent or guardian, to have a conference with the Principal ordering the short-term suspension before or at the time the student returns to school. The Principal shall determine who, in addition to the parent or guardian, is to attend the conference.
4. Students who are short-term suspended will be given the opportunity to complete classwork, including but not limited to examinations.

Emergency Exclusion

Students may be emergency excluded from school pursuant to the board's separate policy on emergency exclusion or state law.

Weapons and/or Firearms

Students may be disciplined for the possession of weapons and/or firearms pursuant to the board's separate policy on weapons and firearms or state law.

Long-Term Suspension

Students may be excluded by the Principal from school or any school function for a period of more than five school days but less than twenty school days (long-term suspension) for any conduct constituting grounds for expulsion as hereinafter set forth. The process for long-term suspension is set forth below.

Expulsion

1. **Meaning of Expulsion.** Expulsion means exclusion from attendance in all schools, grounds and activities of or within the system for a period not to exceed the remainder of the semester in which it took effect unless the misconduct occurred (a) within ten school days prior to the end of the first semester, in which case the expulsion shall remain in effect through the second semester, or (b) within ten school days prior to the end of the second semester, in which case the expulsion shall remain in effect for summer school and the first semester of the following school year, or (c) unless the expulsion is for conduct specified in these rules or in law as permitting or requiring a longer removal, in which case the expulsion shall remain in effect for the period specified therein. Such action may be modified or terminated by the school district at any time during the expulsion period.
2. **Summer Review.** Any expulsion that will remain in effect during the first semester of the following school year will be automatically scheduled for review before the beginning of the school year. The review will be conducted by the hearing officer who conducted the initial expulsion hearing, or a hearing officer appointed by the Superintendent in the event no hearing was previously held or the initial hearing officer is no longer available or willing to serve, after the hearing officer has given notice of the review to the student and the student's parent or guardian. This review shall be limited to newly discovered

evidence or evidence of changes in the student's circumstances occurring since the original hearing. This review may lead to a recommendation by the hearing officer that the student be readmitted for the upcoming school year. If the school board or board of education or a committee of such board took the final action to expel the student, the student may be readmitted only by action of the board. Otherwise the student may be readmitted by action of the Superintendent.

3. **Suspension of Enforcement of an Expulsion:** Enforcement of an expulsion action may be suspended (i.e., "stayed") for a period of not more than one full semester in addition to the balance of the semester in which the expulsion takes effect, and as a condition of such suspended action, the student may be assigned to a school, class, or program/plan and to such other consequences which the school district deems appropriate.
4. **Alternative School or Pre-expulsion Procedures.** The school shall either provide an alternative school, class or educational program for expelled students or shall follow the pre-expulsion procedures outlined in NEB. REV. STAT. 79-266.

Grounds for Long-Term Suspension, Expulsion or Mandatory Reassignment:

The following conduct constitutes grounds for long-term suspension, expulsion, or mandatory reassignment, subject to the procedural provisions of the Student Discipline Act, NEB. REV. STAT. § 79-254 through 79-296, when such activity occurs on school grounds, in a vehicle owned, leased, or contracted by a school being used for a school purpose or in a vehicle being driven for a school purpose by a school employee or by his or her designee, or at a school-sponsored activity or athletic event:

1. Use of violence, force, coercion, threat, intimidation, or similar conduct in a manner that constitutes a substantial interference with school purposes;
2. Willfully causing or attempting to cause substantial damage to property, stealing or attempting to steal property of substantial value, or repeated damage or theft involving property;
3. Causing or attempting to cause personal injury to a school employee, to a school volunteer, or to any student. Personal injury caused by accident, self-defense, or other action undertaken on the reasonable belief that it was necessary to protect some other person shall not constitute a violation of this subdivision;
4. Threatening or intimidating any student for the purpose of or with the intent of obtaining money or anything of value from such student;
5. Knowingly possessing, handling, or transmitting any object or material that is ordinarily or generally considered a weapon (*see also board policy on weapons and firearms*);
6. Engaging in the unlawful possession, selling, dispensing, or use of a controlled substance or an imitation controlled substance, as defined in section 28-401, a substance represented to be a controlled substance, or alcoholic liquor as defined in section 53-103.02 or being under the influence of a controlled substance or alcoholic liquor (*note: the term "under the influence" for school purposes has a less strict meaning than it does under criminal law; for school purposes, the term means any level of impairment and includes even the odor of alcohol on the breath or person of a student; also, it includes being impaired by reason of the abuse of any material used as a stimulant*);
7. Public indecency as defined in section 28-806, except that this prohibition shall apply only to students at least twelve years of age but less than nineteen years of age;
8. Engaging in bullying as defined in section 79-2,137 and in these policies;
9. Sexually assaulting or attempting to sexually assault any person if a complaint has been filed by a prosecutor in a court of competent jurisdiction alleging that the student has sexually assaulted or

attempted to sexually assault any person, including sexual assaults or attempted sexual assaults which occur off school grounds not at a school function, activity, or event. For purposes of this subdivision, sexual assault means sexual assault in the first degree as defined in section 28-319, sexual assault in the second degree as defined in section 28-320, sexual assault of a child in the second or third degree as defined in section 28-320.01, or sexual assault of a child in the first degree as defined in section 28-319.01, as such sections now provide or may hereafter from time to time be amended;

10. Engaging in any other activity forbidden by the laws of the State of Nebraska which activity constitutes a danger to other students or interferes with school purposes; or
11. A repeated violation of any of the following rules if such violations constitute a substantial interference with school purposes:
 - a. The use of language, written or oral, or conduct, including gestures, which is profane or abusive to students or staff members. Profane or abusive language or conduct includes, but is not limited to, that which is commonly understood and intended to be derogatory toward a group or individual based upon race, gender, national origin, or religion;
 - b. Dressing or grooming in a manner which violates the school district's dress code and/or is dangerous to the student's health and safety, a danger to the health and safety of others, or which is disruptive, distracting or indecent to the extent that it interferes with the learning and educational process;
 - c. Violating school bus rules as set by the school district or district staff;
 - d. Possessing, using, selling, or dispensing tobacco, drug paraphernalia, or a tobacco imitation substance or packaging, regardless of form, including cigarettes, chewing tobacco, and any other form of tobacco or imitation, such as electronic cigarettes, vapor pens, etc.;
 - e. Possessing, using, selling, or dispensing any drug paraphernalia or imitation of a controlled substance regardless of whether the actual substance possessed is a controlled substance by Nebraska law;
 - f. Possession of pornography;
 - g. Sexting or the possession of sexting images (a combination of sex and texting - the act of sending sexually explicit messages or photos electronically);
 - h. Engaging in hazing, defined as any activity expected of someone joining a group, team, or activity that humiliates, degrades or risks emotional and/or physical harm, regardless of the person's willingness to participate. Hazing activities are generally considered to be: physically abusive, hazardous, and/or sexually violating and include but are not limited to the following: personal servitude; sleep deprivation and restrictions on personal hygiene; yelling, swearing and insulting new members/rookies; being forced to wear embarrassing or humiliating attire in public; consumption of vile substances or smearing of such on one's skin; branding; physical beatings; binge drinking and drinking games; sexual simulation and sexual assault;
 - i. Bullying which shall include cyber-bullying, defined as the use of the internet, including but not limited to social networking sites such as Facebook, cell phones or other devices to send, post or text message images and material intended to hurt or embarrass another person. This may include, but is not limited to; continuing to send e-mail to someone who has said they want no further contact with the sender; sending or posting threats, sexual remarks or pejorative labels (i.e., hate speech); ganging up on victims by making them the subject of ridicule in forums, and posting false statements as fact intended to humiliate the victim; disclosure of personal data, such as the victim's real name, address, or school at websites or forums; posing as the identity of the victim for the purpose of publishing material in their name that defames or ridicules them; sending threatening and harassing text, instant messages or emails to the victims; and posting or sending rumors or gossip to instigate others to dislike and gang up on the target;

- j. Violation of the district's computer acceptable computer use policy are subject to discipline, up to and including expulsion; and
- k. Any other violation of a rule or regulation established by a school district staff member pursuant to authority delegated by the board.

Due Process Afforded to Students Facing Long-term Suspension or Expulsion

The following procedures shall be followed regarding any long-term suspension, expulsion or mandatory reassignment

1. On the date of the decision to discipline, the Principal shall file with the Superintendent a written charge and a summary of the evidence supporting such charge.
2. The Principal shall serve the student and the student's parents or guardian with a written notice by registered or certified mail or personal service within two school days of the date of the decision to recommend long-term suspension or expulsion. The notice shall include the following:
 - a. The rule or standard of conduct allegedly violated and the acts of the student alleged to constitute a cause for long-term suspension, expulsion, or mandatory reassignment, including a summary of the evidence to be presented against the student;
 - b. The penalty, if any, which the principal has recommended in the charge and any other penalty to which the student may be subject;
 - c. A statement that, before long-term suspension, expulsion, or mandatory reassignment for disciplinary purposes can be invoked, the student has a right to a hearing, upon request, on the specified charges;
 - d. A description of the hearing procedures provided by the act, along with procedures for appealing any decision rendered at the hearing;
 - e. A statement that the principal, legal counsel for the school, the student, the student's parent, or the student's representative or guardian has the right (i) to examine the student's academic and disciplinary records and any affidavits to be used at the hearing concerning the alleged misconduct and (ii) to know the identity of the witnesses to appear at the hearing and the substance of their testimony; and
 - f. A form on which the student, the student's parent, or the student's guardian may request a hearing, to be signed by such parties and delivered to the principal or superintendent in person or by registered or certified mail.
3. When a notice of intent to discipline a student by long-term suspension, expulsion, or mandatory reassignment is filed with the superintendent, the student may be suspended by the principal until the date the long-term suspension, expulsion, or mandatory reassignment takes effect if no hearing is requested or, if a hearing is requested, the date the hearing examiner makes the report of his or her findings and a recommendation of the action to be taken to the superintendent, if the principal determines that the student must be suspended immediately to prevent or substantially reduce the risk

of (a) interference with an educational function or school purpose or (b) a personal injury to the student himself or herself, other students, school employees, or school volunteers.

4. Nothing in this policy shall preclude the student, student's parents, guardian or representative from discussing and settling the matter with appropriate school personnel prior to the hearing stage.
5. If a hearing is requested within five days after receipt of the notice, the Superintendent shall appoint a hearing officer who shall follow the "hearing procedures" outlined below.
6. If a hearing is requested more than five school days following the receipt of the written notice, but not more than thirty calendar days after receipt, the Superintendent shall appoint a hearing officer who shall follow the "hearing procedures" outlined below, except that the time constraints set forth may differ as provided by law and this policy. The student shall be entitled to a hearing but the consequence imposed may continue in effect pending final determination.
7. If a request for hearing is not received within thirty calendar days following the mailing or delivery of the written notice, the student shall not be entitled to a hearing.

In the event a hearing is requested, the hearing, hearing procedures, the student's rights and any appeals or judicial review permitted by law shall be governed by the applicable provisions of the Nebraska Student Discipline Act (NEB. REV. STAT. § 79-254 to 79-294). The school district will provide parents with copies of the relevant statutes upon request.

Reporting Requirement to Law Enforcement

Violations of this section will result in a report to law enforcement if:

1. The violation includes possession of a firearm;
2. The violation results in child abuse;
3. It is a violation of state law that the administration believes cannot be adequately addressed solely by discipline from the school district;
4. It is a violation of state law that endangers the health and welfare of staff or students;
5. It is a violation of state law that interferes with school purposes;
6. The report is required or requested by law enforcement or the county attorney.

Reference: KSB 5035
Perry 5101

Adopted on: July 20, 2015
Revised on: August 14, 2017
Revised on: July 16, 2018
Revised on: November 12, 2018