



Work Session

Thursday, July 7, 2022 @ 6:00 PM Central
Board Room at HPS District Offices, 1515 W 8th Street, Hastings, NE 68901

1. Roll Call -
2. Announcement - Jim Boeve -
3. Welcome to HEA reps and guests - Jim Boeve -
4. Review Board Norms/Goal - Jim Boeve -
5. Quarterly Financial Report - Jeff Schneider -
6. Budget of Expenses for 2022-23 - Jeff Schneider -
7. Emergency Operations Plan update - Jeff Schneider -
8. Approve appointment of Dr. Thomas Szlanda as the Board Secretary - Jeff Schneider -
9. Approve second reading of revised Policy 404.065: Title IX Procedures for Complaints of Sexual Harassment - Dr. Kandace Garwood -
10. Approve second reading of revised Policy 404.07: Drug & Substance Use Testing - Dr. Thomas Szlanda -

11. Approve second reading of revised Policy 604.03: Students with Disabilities - Dr. Kandace Garwood -

12. Approve Senior High Auditorium project bids - Trent Kelly and Craig Kautz -

13. Approve Furniture bids for Alternative Learning Center - Dr. Kandace Garwood -

14. Approve Request for Certificated Leave of Absence - Jeff Schneider -

15. Ratify bid for Food Service equipment - Tom Szlanda and Jeff Schneider -

16. *Consent Agenda - Dr. Thomas Szlanda -

17. Reminders - Jim Boeve -

18. Adjournment - Jim Boeve -

***Closed Session:** If, during the course of the meeting, discussion of any item on the agenda should be held in a closed meeting, the board will conduct a closed meeting in accordance with the Nebraska Open Meetings Law.

****Sequence of Agenda:** The sequence of agenda topics is subject to change at the discretion of the board. Please arrive at the beginning of the meeting.

*****Action Item:** The board reserves the right to take action on an item listed on the board agenda.

Students, staff, families and community will collaborate to maximize readiness for our student's college/career and citizenship. We will increase the rigor and relevance of each student's learning experience while meeting their academic and well-being needs.

Hastings Public Schools

Board of Education Norms

We will work to achieve consensus while valuing differences of opinion both within our Board and when considering the input of others.

We will conduct meetings and business in a manner that is fair and professional.

We will strive to ensure our decisions are congruent with the mission, vision, and strategic plan for the District.

Each member will be committed to the School Board process by attending meetings, being on time, coming prepared, adhering to the agenda (the President of the Board may adjust the order of the agenda to allow the fullest participation of the available members of the Board upon the request of a Board Member), *referencing Robert's Rules of Order*, and participating to their full potential.

We will gather the necessary data; seek expertise from within and outside of our District; and attempt to hear from any parent, student, or other community member in order to make wise decisions that reflect all stakeholders.

We will regularly and intentionally communicate with one another, the administration, faculty, staff, students, community, and the press to ensure information is shared openly and in a relevant, timely and appropriate manner.

We will also maintain confidentiality when necessary.

We will serve as advocates for K-12 public education within our community, as well as within the state of Nebraska.

We will recognize that, as community leaders, we will adhere to the character standards that are the core of our school: respect, responsibility, compassion, and honesty.

Our collective and fundamental purpose is to assure all students acquire the knowledge, skills, and behaviors essential to be successful individuals and responsible citizens.

General Fund					
2019-20		2020-21		2021-22	
Balance 9-1-19	4,990,774	Balance 9-1-20	5,784,655	Balance 9-1-21	7,212,193
Qtr 1-3 Expenses	30,905,017	Qtr 1-3 Expenses	31,793,406	Qtr 1-3 Expenses	33,840,112
Qtr 1-3 Receipts	36,700,464	Qtr 1-3 receipts	37,784,508	Qtr 1-3 receipts	40,342,869
6/1/2019 balance	\$10,786,220.70	6/1/21 balance	\$11,775,757.00	6/1/22 balance	13,714,950
2019- 20 Qtr 1-3 total	\$5,795,447.00	2020-21 Qtr 1-3 total	\$5,991,102.00	2021-22 Qtr 1-3 total	6,502,757
Cooperative Fund					
Balance 9-1-19	2,780,713	Balance 9-1-20	1,489,433	Balance 9-1-21	1,838,359
Qtr 1-3 Expenses	1,199,021	Qtr 1-3 Expenses	349,938	Qtr 1-3 Expenses	333,855
Qtr 1-3 Receipts	19,522	Qtr 1-3 Receipts	1,821	Qtr 1-3 Receipts	26069
6-1-20 Balance	1,601,214	6-1-21 balance	1,141,316	6-1-22 balance	1,530,573
19-20 total	-1,179,499	20-21 total	-348,117	21-22 total	-307,786
Qtr 1-3 Total	\$4,615,948.00	Qtr 1-3 total	\$5,642,985.00	Qtr 1-3 total	6,194,971

Budget of Expenditures
22-23

Description	18-19 Actual	19-20 Actual	2020-21 Actual	21-22 Est. Expend	2022-23 Est Budget
Teachers, Paras, Supplies	20,247,294	20,712,295	21,180,183	21,175,000	24,000,000
Sped teachers, Sped Paras, Supplies	7,716,299	7,231,986	7,431,710	7,870,000	8,200,000
Counselors, Nurses, Library Personnel, Supplies)	1,519,645	1,256,374	1,276,530	1,280,000	1,900,000
Administrators, Office personnel, supplies, HR expenses, Board Expenses, Legal Fees, Property Insurance, Textbooks, Computers	5,086,153	4,786,219	4,974,037	5,200,000	5,200,000
Custodians, Supplies & Equipment, Vehicles other than other than busses, utility expenses	2,153,158	1,887,599	2,111,000	2,300,000	2,500,000
Maintenance personnel, equipment and supplies,	1,275,077	1,139,806	1,158,064	1,200,000	1,400,000
Activity Transportation	331,792	517,604	290,252	300,000	500,000
Sped Transportation	493,695	597,095	475,542	470,000	600,000
Teachers, Paras, and supplies for Federal programs such as Title and Pre-School	2,444,367	2,753,925	3,417,924	5,200,000	5,200,000
Total Expenditures	41,267,480	40,882,903	42,315,242	44,995,000	
Total Budgeted	47,687,994	46,520,819	47,800,033	47,800,033	49,500,000

Community RelationsTitle IX – Procedure for Complaints of Sexual Harassment**A. Complaint Procedure - Generally**

All employees are responsible for helping to prevent sexual harassment. Employees, or students, who believe they have been subjected to, or believe they have witnessed sexual harassment should follow these procedures:

1. Directly inform the person engaging in the discrimination or harassment that such conduct is offensive and must stop.
2. For employee reporters, contact your principal or supervisor, the principal or supervisor of the offending person, or the Title IX Coordinator if you do not wish to communicate directly with the person whose conduct is offensive or if direct communication with the offending person has been ineffective.
3. Report the matter to the Title IX Coordinator if the offending conduct continues or has not been resolved to your satisfaction after you have reported the matter to a principal or supervisor.
4. For student reporters, contact any teacher, counselor, or administrator.
5. Report to the Title IX Coordinator if you are the adult to whom the student has made a report so that the matter can be properly resolved. The Title IX Coordinator may file a formal complaint and begin the following complaint procedure.

Allegations of sexual harassment or discrimination shall be investigated and, if substantiated, corrective or disciplinary action taken, up to and including dismissal from employment if the offender is an employee, or suspension and/or expulsion, if the offender is a student. Retaliatory action will not be taken against an employee or student for reporting discrimination or harassment.

B. Response to a Formal Complaint:

1. Filing Formal Complaint: An employee or student can allege sexual harassment by filing a formal complaint in writing with the Title IX Coordinator in person or by mail, or by electronic mail using the following contact information:

DIRECTOR OF SPECIAL EDUCATION
1924 WEST A STREET, HASTINGS, NE 68901
402-461-7516

The formal complaint must be signed by the complainant or by the Title IX Coordinator. **The following procedures apply only in the event that a formal complaint is filed. All other allegations of sexual harassment shall be resolved using the general complaint procedure. Any timelines set forth in the following procedures may be extended by the Title IX Coordinator with notice to the parties.**

2. Immediate Actions upon Receipt of Formal Complaint: Upon receipt of a formal complaint, the Title IX Coordinator shall provide the following to all known parties of (A): The complaint procedure as outlined in this regulation; and (B): Notice of the allegations of sexual harassment, including: (i) the identities of the parties involved, if known; and (ii) the conduct allegedly constituting sexual harassment; and (iii) the date and location of the alleged incident.

The parties to the formal complaint may select an advisor of their choice, who may be, but is not required to be, an attorney.

3. Investigation of Formal Complaint: Upon receipt of a formal complaint, the Title IX Coordinator shall notify the Investigator. The Investigator will promptly investigate all complaints of discrimination, even if an outside entity or law enforcement agency is investigating a complaint involving the same facts and allegations. The Investigator will not wait for the conclusion or outcome of a criminal investigation or proceeding to begin an investigation required by this complaint procedure. If the allegation(s) involves possible criminal conduct, the District will notify the complainant of his or her right to file a criminal complaint, and District employees will not dissuade the complainant from filing a criminal complaint either during or after the District's investigation.

The Investigator will aim to complete its investigation within a reasonable time frame, as determined by the Title IX Coordinator. The factors to determine a reasonable time frame include, but are not limited to, the allegations of the formal complaint, the number of witnesses that may need to be interviewed, and whether the police are also conducting an investigation into the allegations. The time frame originally set by the Title IX Coordinator may be extended by the Title IX Coordinator, upon notice to the parties, as he or she deems necessary to complete the investigation. Periodic status updates will be given to the parties, when appropriate.

(A) *Neutrality:* The Title IX Coordinator, investigator, decision-maker, or any person designated by the District to facilitate this complaint procedure, shall not have any conflict of interest or bias for or against complainants or respondents generally or an individual complainant

or respondent. The District shall ensure that Title IX Coordinators, investigators, decision-makers, and any persons who facilitate this complaint procedure shall receive training on the definition of sexual harassment in accordance with this regulation, the scope of the District's education program or activity, how to conduct an investigation and complaint process including hearings, appeals, and informal resolution processes, as applicable, and how to serve impartially, including by avoiding prejudice of the fact at issue, conflicts of interest, and bias. The District shall ensure that the individuals involved in the complaint procedure receive training on issues of relevance of questions and evidence and on issues of relevance to create an investigative report that fairly summarizes relevant evidence.

(B) *Burden of Production*: It shall be the Investigator's burden to gather evidence sufficient to reach a determination regarding responsibility. To reach a determination, the investigation will include, but is not limited to:

- a. Providing the parties with the opportunity to present witnesses and provide evidence.
- b. An evaluation of all relevant information and documentation relating to the alleged discriminatory conduct.
- c. For allegations involving harassment, some of the factors the District will consider include: 1) the nature of the conduct and whether the conduct was unwelcome, 2) the surrounding circumstances, expectations, and relationships, 3) the degree to which the conduct affected one or more students' education, 4) the type, frequency, and duration of the conduct, 5) the identity of and relationship between the alleged harasser and the suspect or suspects of the harassment, 6) the number of individuals involved, 7) the age (and sex, if applicable) of the alleged harasser and the alleged victim(s) of the harassment, 8) the location of the incidents and the context in which they occurred, 9) the totality of the circumstances, and 10) other relevant evidence.
- d. A review of the evidence using a "preponderance of the evidence" standard (based on the evidence, is it more likely than not that discrimination, harassment, or retaliation occurred?)

(C) *Rights of the Parties*: The respondent is entitled to a presumption that the respondent is not responsible for the alleged conduct until a determination regarding responsibility is made at the conclusion of the complaint process.

The Investigator must provide an equal opportunity for the parties to present witnesses, including fact and expert witnesses, and other inculpatory and exculpatory evidence.

The Investigator shall not restrict the ability of either party to discuss the allegations under investigation or to gather and present relevant evidence.

The Investigator shall provide the parties with the same opportunities to have others present during any complaint proceeding, including the opportunity to be accompanied to any related meeting or proceeding by the advisor of their choice if the Investigator deems appropriate. However, the Investigator may establish restrictions regarding the extent to which the advisor may participate in the proceedings, if the restrictions apply equally to both parties.

The Investigator shall provide to all witnesses expected to attend a meeting notice of the date, time, location, participants, and purpose of all hearings within two (2) days of the meeting.

Up until the conclusion of the investigation, the parties shall have an equal opportunity to inspect and review any evidence obtained as part of the investigation that is directly related to the allegations raised in the formal complaint. This includes the evidence upon which the Investigator does not intend to rely in reaching a determination regarding responsibility and inculpatory or exculpatory evidence obtained from any source, so that each party can meaningfully respond to the evidence prior to conclusion of the investigation.

The District retains the right to place an employee on administrative leave during the pendency of an investigation. The District also retains the right to remove a student from the District's educational program prior to the conclusion of the investigation. In the event of a removal, the respondent shall have the opportunity to challenge the decision for removal.

(D) *Conclusion of Investigation:* Prior to the conclusion of the investigation, the investigator shall send each party and the party's advisor, if any, the evidence that is subject to inspection and review in an electronic format or a hard copy. The parties shall then have ten (10) days to submit a written response, which the investigator will consider.

Once the investigator has considered the written statements of the parties, if any, and any questions of the parties, if any, the investigator shall create an investigative report that fairly summarizes relevant evidence. The investigator shall then submit the written investigation report to the decision-maker. The parties shall each receive a copy of the final investigative report at the same time as the decision-maker.

4. Decision of Responsibility: The decision-maker shall review the investigative report. Prior to coming to a determination regarding responsibility, the decision-maker shall provide ten (10) days for each party to submit written, relevant questions that a party wants asked of any party or witness, provide each party with answers, and allow for additional, limited follow-up questions from each party.

Once the decision-maker has considered the written questions of the parties, if any, the decision-maker shall issue a written determination regarding responsibility by a preponderance of the evidence within a reasonable time frame as determined by the Title IX Coordinator. The decision-maker shall consider all relevant evidence, including inculpatory and exculpatory evidence, and will not consider the credibility of the evidence to be based on a person's status, such as complainant, respondent, or witness. The decision-maker shall provide the written determination to both parties simultaneously. The written determination must include:

- a. Identification of the allegations potentially constituting sexual harassment;
- b. A description of the procedural steps taken from the receipt of the formal complaint through the determination, including any notifications to the parties, interviews with parties and witnesses, site visits, and methods used to gather evidence;
- c. Findings of fact supporting the determination;

- d. Conclusions regarding the application of each recipient's code of conduct to the facts;
- e. A statement of, and rationale for, the results as to each allegation, including a determination regarding responsibility, any disciplinary sanctions the recipient imposes on the respondent, and whether remedies designed to restore or preserve equal access to the recipient's education program or activity will be provided by the recipient to the complainant; and
- f. The recipient's procedures and permissible bases for the complainant and respondent to appeal.

The Family Educational Rights and Privacy Act (FERPA), 20 U.S.C. Sec. 11232g; 34 C.F.R. Part 99, permits the District to disclose relevant information to a student who was discriminated against or harassed.

5. Supportive Measures and Disciplinary Actions:

Throughout the investigation, either party may be entitled to supportive measures. Supportive measures are non-disciplinary, non-punitive individualized services offered as appropriate, as reasonably available, and without fee or charge to the complainant or the respondent before or after the filing of a formal complaint or where no formal complaint has been filed. Such measures are designed to restore or preserve equal access to the recipient's education program or activity without unreasonably burdening the other party, including measures designed to protect the safety of all parties or the District's educational environment to deter sexual harassment.

Supportive measures may include, but are not limited to, counseling, extensions of deadlines or other course-related adjustments, modifications of work or class schedules, campus escort services, mutual restrictions on contact between the parties, changes in work or housing locations, leaves of absence, increased security and monitoring of certain areas of the campus, and other similar measures. The District shall maintain as confidential any supportive measures provided to the complainant or respondent, to the extent that maintaining such confidentiality would not impair the ability of the District to provide the supportive measures.

At the conclusion of the investigation, the decision-maker may institute disciplinary measures to the respondent if the decision-maker determines that the respondent engaged in sexual abuse or harassment. Disciplinary measures may include, but are not limited to, in-school suspension, out-of-school suspension, expulsion, and in the case of an employee, disciplinary action up to and including dismissal from employment. This policy does not limit or prohibit the District from instituting disciplinary measures if, in the course of the investigation, it determines that the complainant or respondent violated the student code of conduct.

The Title IX Coordinator is responsible for coordinating the effective implementation of supportive measures.

C. Appeals

If either party is not satisfied with the outcome of the investigation and the decision of the decision-maker, they may appeal on the following basis:

- a. Procedural irregularity that affected the outcome of the matter;
- b. New evidence, that was not reasonably available at the time the determination regarding responsibility or dismissal was made, that could affect the outcome of the matter; and
- c. The Title IX Coordinator, investigator, or decision-maker had a conflict of interest or bias for or against the complainant or respondent generally or the individual complainant or respondent that affected the outcome of the matter.

The request for an appeal shall be in writing and submitted on the appropriate document. The appeal document shall be submitted to the Superintendent of Schools.

Upon notice of an appeal by either party, the Superintendent of Schools shall notify the other party in writing when the appeal is filed and of the appeal procedures, which apply equally to both parties.

The Superintendent of Schools shall give both parties a reasonable and equal opportunity to submit a written statement in support of, or challenging the outcome.

The Superintendent of Schools shall review the investigative report, decision-maker's determination, and written statements of the parties and then issue a written decision describing the result of the appeal and the rationale for the result. The Superintendent of Schools shall provide the written decision simultaneously to both parties.

D. Informal Resolution

If a formal complaint is filed, the District may offer the complainant and respondent the opportunity to participate in an informal resolution process. The informal resolution process may take place at any time prior to reaching a determination regarding responsibility. The informal resolution process shall only take place upon:

- a. Written notice to both parties disclosing: the allegations, the requirements of the informal resolution process, including the circumstances under which it precludes the parties from resuming a formal complaint arising from the same allegations, provided, however, that at any time prior to agreeing to a resolution, any party has the right to withdraw from the resolution process and resume the complaint process with respect to the formal complaint, and any consequences resulting from participating in the informal resolution process, including the records that will be maintained or could be shared;
- b. The parties' voluntary written consent to the informal resolution process; and
- c. That the allegations of the formal complaint do not involve any allegations that an employee sexually harassed a student.

E. Record Keeping

The District will maintain relevant documentation obtained during the investigation and documentation supportive of the findings and any subsequent determinations, including the investigative report, witness statements, interview summaries, any transcripts, or audio recordings pertaining to the investigative and appeal proceedings for a period of seven (7) years.

Legal Reference: Title IX

Date of Adoption: [Insert Date]

Community RelationsTitle IX – Procedure for Complaints of Sexual Harassment**A. Complaint Procedure - Generally**

1. Reporting Procedures: All employees are responsible for helping to prevent sexual harassment. Employees or students who believe they have been subjected to, or believe they have witnessed sexual harassment should follow these procedures:

1. Directly inform the person engaging in the discrimination or harassment that such conduct is offensive and must stop.
2. For employee reporters, contact your principal or supervisor, the principal or supervisor of the offending person, or the Title IX Coordinator if you do not wish to communicate directly with the person whose conduct is offensive or if direct communication with the offending person has been ineffective.
3. Report the matter to the Title IX Coordinator if the offending conduct continues or has not been resolved to your satisfaction after you have reported the matter to a principal or supervisor.
4. For student reporters, contact any teacher, counselor, or administrator, or the Title IX Coordinator.
5. Report to the Title IX Coordinator if you are the adult to whom the student has made a report so that the matter can be properly resolved. The Title IX Coordinator is:

TITLE IX COORDINATOR CONTACT INFORMATION

Dr. Kandace Garwood

1515 W 8th Street

Hastings, NE 68901

402-461-7516

kandace.garwood@hpstigers.org

2. District Actions upon Report of Sexual Harassment or Sexual Misconduct: Upon receipt of a report of sexual harassment, the Title IX Coordinator, or designee, including but not limited to a building principal or assistant principal, will conduct an initial inquiry. The first step of the inquiry will typically include a preliminary meeting between the individual whom the reporting party alleges has been subjected to sexual harassment or sexual misconduct and the Title IX Coordinator, or designee. The initial inquiry may also include a meeting between the Title IX Coordinator, or designee, and the individual whom the reporting party alleges has committed sexual harassment or sexual misconduct. The purpose of these meetings is to gain a basic understanding of the

nature and circumstances of the report, it is not intended to be a full investigative interview. During the initial assessment, the reporting party may also receive information about resources, rights, procedural options, and supportive measures. The Title IX Coordinator, or designee, may inquire into whether the person who has is alleged to have been subject to sexual harassment or misconduct requests resources, no further action, supportive measures, and/or initiation of the "Formal Complaint" process. The Title IX Coordinator will make a reasonable effort to respect the wishes of the person who experienced sexual harassment or sexual misconduct; however, if the reported incident constitutes an imminent or ongoing threat to school safety, based on the assessment of the Title IX Coordinator, then the Title IX Coordinator may file a Formal Complaint, on behalf of the District, with or without the consent or permission of the person who has experienced sexual harassment or sexual misconduct.

With or without a Formal Complaint, allegations of sexual harassment or discrimination shall be investigated and if substantiated, corrective or disciplinary action will be taken, up to and including dismissal from employment, if the offender is an employee, or suspension and/or expulsion, if the offender is a student. Retaliatory action will not be taken against any person for reporting discrimination or harassment. This policy does not limit or prohibit the District from instituting disciplinary measures pursuant to other Board Policy, rules, or other expectations if the District determines that a person violated District rules or expectations.

B. Formal Complaint Process

The following procedures apply only in the event that a Formal Complaint is filed. All other reports of sexual harassment shall be resolved using the general complaint procedure. Any timelines set forth in the following procedures may be extended by the Title IX Coordinator with notice to the parties.

1. Misconduct Which May Be Investigated Under a Formal Complaint: The Formal Complaint process is only available if the Formal Complaint alleges: (i) conduct which occurs on District grounds or property owned or controlled by the District; (ii) conduct which occurs in the context of District employment or an education program or District-sponsored activity within the United States, and (iii) conduct which occurs when the District has substantial control over both the Respondent and the context in which the sexual harassment or sexual misconduct occurs. The conduct must also fall within one of the following categories: (a) an employee of the District conditioning an aid, service, or benefit of the District on an individual's participation in unwelcome sexual contact; (b) unwelcome conduct determined by a reasonable person to be so severe, pervasive, and objectively offensive that it effectively denies a student equal access to the District's education program or activity; (c) sexual assault; (d) domestic violence; (e) dating violence; or (f) stalking.

2. Parties to a Formal Complaint: The only parties to a Formal Complaint are the Complainant, who is the person alleged to have been subject to misconduct, and the Respondent, the person who is alleged to have committed the misconduct.

3. Filing a Formal Complaint: A Formal Complaint may only be filed by a Complainant or the Title IX Coordinator. An employee or student Complainant may file a Formal Complaint in writing with the Title IX Coordinator in person or by mail, or by electronic mail. The Formal Complaint must be signed by the Complainant or by the Title IX Coordinator.

4. Immediate Actions Upon Receipt of Formal Complaint: Upon receipt of a Formal Complaint, the Title IX Coordinator will conduct an initial assessment of the allegations contained within the Formal Complaint to determine if the allegations in the Formal Complaint, if true, allege misconduct which may be investigated under the Formal Complaint process. If the allegations in the Formal Complaint do not allege misconduct which may be investigated under the Formal Complaint process, the Title IX Coordinator must dismiss the Formal Complaint and may proceed under other District policies or procedures. The Complainant will be provided notice in writing if the Formal Complaint is dismissed.

If the allegations in the Formal Complaint allege misconduct which may be investigated under the Formal Complaint process, the Title IX Coordinator shall provide the following to all known parties: (1) The complaint procedure as outlined in this policy; and (2) Notice of the allegations of sexual harassment, known by the District at the time of filing the Notice, including (i) the identities of the parties involved, if known, (ii) the conduct allegedly constituting sexual harassment, and (iii) the date and location of the alleged incident.

The Title IX Coordinator shall then provide the Formal Complaint and the Notice of the Formal Complaint to the District's Title IX Investigator.

5. Investigation of Formal Complaint: Upon receipt of a Formal Complaint, the Investigator will promptly investigate the allegations contained within, even if an outside entity or law enforcement agency is investigating a complaint involving the same facts and allegations. The Investigator will not wait for the conclusion or outcome of a criminal investigation or proceeding to begin an investigation required by this complaint procedure. If the allegation(s) involve possible criminal conduct, the District will notify the Complainant of his or her right to file a criminal complaint, and District employees will not dissuade the Complainant from filing a criminal complaint either during or after the District's investigation.

The Investigator will contact the Complainant, Respondent, and relevant witnesses to schedule interviews. All parties may bring up to two people to this meeting: (1) Support Person and/or (2) Advisor of Choice. The Advisor of Choice may or may not be an attorney. Neither the Support Person nor the Advisor of Choice can direct questions or comments to the Investigator, nor may the Support Person or Advisor of Choice advise a student or employee how to answer the Investigator's questions.

The Investigator will also aim to collect all tangible evidence relevant to the investigation.

The Investigator will complete the investigation within a reasonable time frame, as determined by the Title IX Coordinator. The factors to determine a reasonable time frame include, but are not limited to, the allegations of the Formal Complaint and the number of witnesses that may need to be interviewed. The time frame originally set by the Title IX Coordinator may be extended by the Title IX Coordinator, upon notice to the parties, as deemed necessary to complete the investigation. Periodic status updates will be given to the parties, when appropriate.

(A) *Neutrality*: The Title IX Coordinator, Investigator, Decision-Maker, or any person designated by the District to facilitate this Formal Complaint process, shall not have any conflict of interest or bias for or against Complainants or Respondents generally or an individual Complainant or Respondent. The District shall ensure that Title IX Coordinator, Investigator, Decision-Maker, and any person who facilitates this Formal Complaint process shall receive training on the definition of sexual harassment, the scope of the District's education program or activity, how to conduct an investigation and complaint process including hearings, appeals, and informal resolution processes, as applicable, and how to serve impartially, including by avoiding prejudgment of the fact at issue, conflicts of interest, and bias.

(B) *Burden of Production*: It shall be the Investigator's burden to gather evidence sufficient to reach a determination regarding the outcome of the Formal Complaint. To reach a determination, the investigation will include, but is not limited to:

- i. Providing the parties with the opportunity to present witnesses and provide evidence.
- ii. An evaluation of all relevant information and documentation relating to the alleged discriminatory conduct.
- iii. A consideration of various factors, including: (1) the nature of the conduct and whether the conduct was unwelcome, (2) the surrounding circumstances, expectations, and relationships, (3) the degree to which the conduct affected one or more students' education, (4) the type, frequency, and duration of the conduct, (5) the identity of and relationship between the alleged harasser and the suspect or suspects of the harassment, (6) the number of individuals involved, (7) the age and sex, if applicable, of the alleged harasser and the alleged victim(s) of the harassment, (8) the location of the incidents and the context in which they occurred, (9) the totality of the circumstances, and (10) other relevant evidence.
- iv. A review of the evidence using a "preponderance of the evidence" standard. To meet the "preponderance of the evidence" standard, the evidence must show that the discrimination, harassment, or retaliation more likely occurred than did not occur.

(C) *Rights of the Parties:* The Respondent is entitled to a presumption that the Respondent is not responsible for the alleged conduct until a determination regarding responsibility is made at the conclusion of the complaint process. The Investigator must provide an equal opportunity for the parties to present witnesses, including fact and expert witnesses, and other inculpatory and exculpatory evidence. The Investigator shall not restrict the ability of either party to discuss the allegations under investigation or to gather and present relevant evidence.

The District retains the right to place any person on administrative leave during the pendency of the investigation. The District also retains the right to remove a Respondent from the District's educational program prior to the conclusion of the investigation. In the event of a removal, the Respondent shall have the opportunity to challenge the decision for removal by meeting with the Title IX Coordinator to discuss the removal.

(D) *Conclusion of Investigation:* Prior to the conclusion of the investigation, the Investigator shall send each party the evidence that is subject to inspection and review in an electronic format or a hard copy. This information shall be known as the "Draft Investigative Report." The Draft Investigative Report shall include all evidence obtained as part of the investigation that is directly related to the allegations raised in the Formal Complaint, including the evidence upon which the Investigator does not intend to relay to the Decision-Maker. The parties shall then have ten (10) calendar days to submit a written response, which the Investigator will consider. Responses may not be submitted by the parties' Advisor of Choice or Support Person, unless such person is the parent or guardian of the Complainant or Respondent. Responses may include corrections to the Investigator's summary of the parties' interviews, suggestions for additional investigation, or additional information not known at the time of the interviews. Any new information provided by the parties during the response period will not result in an additional time period for response by the other party unless determined necessary by the Title IX Coordinator. The Investigator is not obliged to respond to any question or requests for information in the parties' responses. The Investigator will consider the information provided by the parties and will incorporate relevant information into the Final Investigative Report. The Final Investigative Report will fairly summarize the relevant evidence. The Investigator shall then submit the Final Investigation Report to the Decision-Maker. The parties shall each receive a copy of the Final Investigative Report at the same time as the Decision-Maker.

6. Actions Taken By Decision-Maker Upon Receipt of Final Investigative Report: Upon receipt of the Final Investigative Report, the Decision-Maker shall provide 10 days for each party to submit written, relevant questions that a party wants asked of any party or witness. Questions shall be submitted to the Title IX Coordinator who shall determine whether questions are relevant. The Title IX Coordinator shall contact parties or witnesses to request answers to the parties' relevant questions. The Title IX Coordinator will provide each party, and the Decision-Maker with the answers provided by the opposing party or witness and allow for additional, limited follow-up questions from each party.

7. Notice of Determination: Once the Decision-Maker has received the answers to relevant questions submitted by the parties, the Decision-Maker shall consider the answers and the Decision-Maker shall issue a written determination regarding responsibility by a preponderance of the evidence within a reasonable time frame, as determined by the Title IX Coordinator. The Decision-Maker shall consider all relevant evidence, including inculpatory and exculpatory evidence, and will not consider the credibility of the evidence to be based on a person's status, such as the Complainant, Respondent, or witness. The Decision-Maker shall provide the written determination to both parties simultaneously. The written determination shall include:

- (a) Identification of the allegations potentially constituting sexual harassment;
- (b) A description of the procedural steps taken from the receipt of the Formal Complaint through the determination, including any notifications to the parties, interviews with parties and witnesses, site visits, and methods used to gather evidence;
- (c) Findings of fact supporting the determination;
- (d) Conclusions regarding the application of each recipient's code of conduct to the facts;
- (e) A statement of, and rationale for, the results as to each allegation, including a determination regarding responsibility, any disciplinary sanctions the recipient imposes on the Respondent, and whether remedies designed to restore or preserve equal access to the recipient's education program or activity will be provided by the recipient to the Complainant; and
- (f) The recipient's procedures and permissible bases for the Complainant and Respondent to appeal.

The Family Educational Rights and Privacy Act (FERPA) permits the District to disclose relevant information to a student who was discriminated against or harassed.

8. Sanctions: At the conclusion of the investigation, the Decision-Maker may institute disciplinary measures against the Respondent if the Decision-Maker determines that the Respondent engaged in sexual abuse or harassment. Disciplinary measures may include, but are not limited to, in-school suspension, out-of-school suspension, expulsion, and, in the case of an employee disciplinary action, up to and including immediate termination from employment.

The Title IX Coordinator is responsible for coordinating the implementation of supportive measures for the victim(s).

C. Appeals

If either party is not satisfied with the outcome of the investigation and the decision of the Decision-Maker, they may appeal on the following bases:

1. Procedural irregularity that affected the outcome of the matter;
2. New evidence that was not reasonably available at the time the determination

regarding responsibility or dismissal was made, that could affect the outcome of the matter; and

3. The Title IX Coordinator, Investigator, or Decision-Maker had a conflict of interest or bias for or against the Complainant or Respondent generally or the individual Complainant or Respondent that affected the outcome of the matter.

The request for an appeal shall be in writing and submitted on the appropriate document. The appeal document shall be submitted to the Superintendent.

Upon notice of an appeal by either party, the Superintendent of Schools shall notify the other party in writing when the appeal is filed and of the appeal procedures, which apply equally to both parties.

The Superintendent shall give both parties a reasonable and equal opportunity to submit a written statement in support of, or challenging the outcome.

The Superintendent shall review the investigative report, Decision-Maker's determination, and written statements of the parties and then issue a written decision describing the result of the appeal and the rationale for the result. The Superintendent shall provide the written decision simultaneously to both parties.

D. Informal Resolution

If a Formal Complaint is filed, the District may offer the Complainant and Respondent the opportunity to participate in an informal resolution process. The informal resolution process may take place at any time prior to reaching a determination regarding responsibility. The informal resolution process shall only take place upon:

1. Written notice to both parties disclosing: the allegations, the requirements of the informal resolution process including the circumstances under which it precludes the parties from resuming a Formal Complaint arising from the same allegations, provided, however, that at any time prior to agreeing to a resolution, any party has the right to withdraw from the resolution process and resume the complaint process with respect to the Formal Complaint, and any consequences resulting from participating in the informal resolution process, including the records that will be maintained or could be shared;
2. The parties' voluntary, written consent to the informal resolution process; and
3. That the allegations of the Formal Complaint do not involve any allegations that an employee sexually harassed a student.

E. Record Keeping

The District will maintain relevant documentation obtained during the investigation and documentation supportive of the findings and any subsequent determinations, including the investigative report, witness statements, interview summaries, and any transcripts or

audio recordings, pertaining to the investigative and appeal proceedings for a period of seven (7) years.

Legal Reference: Title IX

Approved: 11/18/02
Reviewed: 06/13/2022
Revised:

HASTINGS PUBLIC SCHOOLS

DRUG AND ALCOHOL POLICY FOR DISTRICT TRANSPORTATION PERSONNEL

Purpose

It is the policy of the Hastings Public Schools (the "District") that its drivers be free of substance use and alcohol abuse. Consequently, drivers shall not use illegal drugs, misuse alcohol, or engage in "prohibited conduct" as defined herein. The overall goal of this policy is to ensure a drug- and alcohol-free transportation environment and to reduce accidents, injuries, and fatalities.

Types of Tests

Pursuant to regulations promulgated by the Department of Transportation (DOT), the District has implemented six circumstances for drug and alcohol tests: (1) pre-employment testing, (2) post-accident testing, (3) random testing, (4) reasonable suspicion testing, (5) return-to-duty testing, and (6) follow-up testing.

Definitions

For the purpose of this policy, the following terms are defined:

Alcohol - The intoxicating agent in beverage alcohol, ethyl alcohol, or other low molecular weight alcohol, including methyl and isopropyl alcohol.

Driver - Any person who operates a commercial motor vehicle. This includes full-time, regularly employed drivers; casual, intermittent, or occasional drivers; leased drivers; and independent, owner-operated contractors. This includes all persons operating vehicles carrying students or persons served by the District.

Drug - Marijuana, cocaine, opiates, amphetamines, and Phencyclidine.

Medical Review Officer - A licensed physician (medical doctor or doctor of osteopathy) responsible for receiving laboratory results generated by an employer's drug testing program who meets the qualifications as listed in 49 C.F.R. 40.3.

Safety-Sensitive Function - Includes all on-duty functions performed from the time a driver begins work or is required to be ready to work until he or she is relieved from work and all responsibility for performing work. It includes driving; waiting to be dispatched; inspecting and servicing equipment; supervising, performing, or assisting in loading and unloading; repairing or obtaining and waiting

for help with a disabled vehicle; performing driver requirements related to accidents; and performing any other work for the District or paid work for any other entity.

Substances Abuse Professional - A licensed physician or certified psychologist, social worker, employee assistance professional, or certified addiction counselor with knowledge of, and clinical experience in, the diagnosis and treatment of alcohol- and drug-related disorders.

Program Administration

The Superintendent or his/her designee shall be the program administrator. The program administrator shall administer this policy according to all applicable state and federal laws, rules, and regulations. The program administrator shall be responsible for answering drivers' questions about this policy.

Refusal of Tests

Refusal to submit to the types of drug and alcohol tests employed by the District after being advised that the requested test is required by DOT regulations will be grounds for refusal to hire driver/applicants and discipline, including termination of employment, of existing drivers. A refusal to test is defined to be conduct which would obstruct the proper administration of a test. A delay in providing a urine or breath specimen could be considered a refusal. If a driver cannot provide a sufficient urine specimen or adequate breath, he/she will be evaluated by a physician of the District's choice. If the physician cannot find a legitimate medical explanation for the inability to provide a specimen (either urine or breath), it will be considered a refusal to test.

Consequences of Policy Violation

Any driver who becomes unqualified or engages in prohibited conduct as set forth herein may be subject to discipline, including termination of employment.

Pre-Employment Testing

All applicants for driving positions must submit to a urine drug test and breath alcohol test. The District does not have to require a urine drug test if the District can verify that the driver has participated in a valid drug-testing program within the preceding thirty (30) days and, while participating in that program, was either tested within the past six (6) months or participated in a random selection program for the previous twelve (12) months. The District must also verify that no prior employer of the driver has records indicating a violation of any DOT rule pertaining to controlled substance use within the previous six (6) months. The District does not have to require a pre-employment alcohol test if the driver/applicant has undergone an alcohol test required under DOT rule within

the previous six (6) months demonstrating an alcohol concentration of less than .04. The District must also ensure that no prior employer of the driver has knowledge or records of a violation of the DOT alcohol rules within the previous six (6) months. If an applicant tests positive for drugs, has a blood alcohol concentration of .04 or greater as shown by the pre-employment test, refuses a pre-employment drug or alcohol test, or fails to provide prior employment records, the District may withdraw any employment offer.

If the driver/applicant has an alcohol test result between .02 and .04, he/she shall not be allowed to drive for twenty-four (24) hours. The driver shall be removed from safety-sensitive functions, and the applicant is not allowed to operate a commercial motor vehicle for twenty-four (24) hours.

Random Testing

The District conducts random drug and alcohol testing. The District or its agents will submit all drivers to a random selection system. The random selection system shall provide an equal chance for each driver to be selected each time random selection occurs. Random selections will be reasonably spread throughout the year. The District will select for random drug tests a minimum of fifty (50) percent of the average number of driver positions in each calendar year. The District will select for random alcohol tests a minimum of twenty-five (25) percent of the average number of driver positions in each calendar year. Random selection, by its very nature, may result in drivers being selected in successive selections more than once a calendar year. Alternatively, some drivers may not be selected in a calendar year.

If a driver is selected at random for either drug or alcohol testing, the District official will notify the driver. Once notified, every action the driver takes must lead to a collection. If the driver engages in conduct which does not lead to a collection as soon as possible after notification, such conduct may be considered a refusal to test. Tests for alcohol shall be administered during, just prior to, or just after performance of a safety-sensitive function by a driver.

Post-Accident Testing

When a driver is involved in an accident where a fatality is involved or is involved in a recorded accident and receives a citation for a moving violation arising from the accident, the driver must submit to a drug and alcohol test as soon as practicable following any accident. The driver has been presented with an information card setting forth certain instructions for post-accident drug and alcohol testing. The driver shall follow the instructions contained on the information card, as well as any additional instructions which come from the District or its representatives.

The DOT requires that, any time a post-accident drug or alcohol test is required, it be performed as soon as practicable following the accident. A driver who is subject to post-accident testing shall remain readily available for such testing or may be deemed by the employer to have refused to submit to testing. Nothing in this section shall be construed to require the delay of necessary medical attention for injured people following an accident or to prohibit a driver from leaving the scene of an accident for the period necessary to obtain assistance in responding to the accident or to obtain necessary emergency medical care.

In the event federal, state, or local officials conduct breath or blood tests for the use of alcohol and/or urine tests for the use of controlled substances following an accident, these tests shall be considered to meet the requirements of this section, provided the tests conform to applicable federal, state, or local requirements and the employee signs a release allowing the District to obtain the test results from federal, state, or local officials.

In the event a driver is so seriously injured that the driver cannot provide a urine or breath specimen at the time of the accident, the driver must provide necessary authorization for the District to obtain hospital records or other documents that would indicate whether there were controlled substances or alcohol in the driver's system at the time of the accident.

Reasonable Suspicion Testing

Tests shall be conducted when a supervisor or District official trained in accordance with law has reasonable suspicion that the driver has violated the District's alcohol or drug prohibitions. This reasonable suspicion must be based on specific, contemporaneous, articulable observations concerning the driver's appearance, behavior, speech, or body odors. The observations may include indications of the chronic and withdrawal effects of controlled substances.

Alcohol tests are authorized for reasonable suspicion only if the required observations are made during, just before, or just after the driver's performance of safety-sensitive functions.

Return-To-Duty Testing

Before a driver returns to duty requiring the performance of a safety-sensitive function after engaging in conduct prohibited by this policy concerning alcohol, the driver shall undergo a return-to-duty alcohol test with a result indicating an alcohol concentration of less than .02.

Before a driver returns to duty requiring the performance of a safety-sensitive function after engaging in conduct prohibited by this policy concerning controlled substances, the driver shall undergo a return-to-duty controlled substances test with a result indicating a verified negative result for controlled substances use.

Follow-Up Testing

Following a determination that a driver is in need of assistance in resolving problems associated with alcohol misuse and/or use of controlled substances, each employer shall ensure that the driver is subject to unannounced follow-up alcohol and/or controlled substances testing as directed by a substance abuse professional.

Follow-up alcohol testing shall be conducted only when the driver is performing safety-sensitive functions, just before the driver is to perform safety-sensitive functions, or just after the driver has ceased performing safety-sensitive functions.

Follow-up testing is separate from, and in addition to, the District's reasonable suspicion, post-accident, and random testing procedures. Follow-up testing shall be on a random basis and be in accordance with the instructions of the Substance Abuse Professional. Follow-up testing may continue for a period of up to sixty (60) months following the driver's return to duty. No fewer than six (6) tests shall be performed in the first twelve (12) months of follow-up testing.

Prohibited Conduct

The following shall be considered "prohibited conduct" for purposes of this policy:

No driver shall report for duty or remain on duty while having an alcohol concentration of .04 or greater.

No driver shall be on duty or operate a commercial motor vehicle while the driver possesses alcohol, unless the alcohol is manifested and transported as part of a shipment.

No driver shall use alcohol while performing safety-sensitive functions.

No driver shall perform safety-sensitive functions within four (4) hours after using alcohol.

No driver required to take a post-accident alcohol test shall use alcohol for eight (8) hours following the accident or until he/she undergoes a post-accident alcohol test, whichever occurs first.

No driver shall refuse to submit to a post-accident, a random, a reasonable suspicion, return-to-duty, or a follow-up breath alcohol or urine drug test.

No driver shall report for duty or remain on duty when the driver uses any controlled substance, except when use is pursuant to the instructions of a physician who has advised the driver that the substance does not adversely affect the driver's ability to operate a commercial motor vehicle.

If the District has actual knowledge or has reason to believe that a driver has engaged in prohibited conduct, the District may require the driver to submit to drug and/or alcohol testing.

If the driver engages in prohibited conduct, the driver is not qualified to drive a commercial motor vehicle and shall be immediately removed from service. The District may, in its discretion, at the request of the driver, keep the driver's position open while such driver attempts to become requalified. The District may also take disciplinary action against the employee up to, and including, termination.

Substance Abuse Evaluation

Any driver who engages in prohibited conduct shall be provided with the names, addresses, and telephone numbers of qualified substance abuse professionals. If the driver desires to become requalified, the driver must be evaluated by a Substance Abuse Professional (SAP) and submit to any treatment prescribed by the SAP. The costs of any SAP evaluation or prescribed treatment shall be borne by the driver. The District does not guarantee or promise a position to the driver should he/she regain qualified status.

Authorization for Previous Test Records

Within fourteen (14) days of performing a safety-sensitive function, federal regulations require that the District obtain drug and alcohol- testing records from the driver's previous employers for the previous two (2) years. As a condition to employment, the driver shall provide the District with a written authorization for all previous employers within the past two (2) years to release such drug and alcohol-testing records as are required under federal regulation.

Drug Urinalysis

Drug testing will be performed through urinalysis. Urinalysis will test for the presence of drugs and/or metabolites of the following controlled substances; (1) marijuana, (2) cocaine, (3) opiates, (4) amphetamines, (5) phencyclidine (PCP).

The urinalysis procedure starts with the collection of a urine specimen. Urine specimens will be submitted to a SAMHSA-certified laboratory for testing. As a part of the collection process, the specimen provided will be split into two vials: a primary vial and a secondary vial. The SAMSHA-certified laboratory will perform

initial screenings on all primary vials. In the event that the primary specimen tests positive, a confirmation test of that specimen will be performed before being reported by the laboratory to the MRO as a positive.

All laboratory results will be reported by the laboratory to a Medical Review Officer (MRO) designated by the District. Negative test results shall be reported by the MRO to the District. Before reporting a positive test result to the District, the MRO will attempt to contact the driver to discuss the test result. If the MRO is unable to contact the driver directly, the MRO will contact the District official designated in advance by the District, who shall, in turn, contact the driver and direct the driver to contact the MRO. Upon being so directed, the driver shall contact the MRO immediately or, if after the MRO's business hours and the MRO is unavailable, at the start of the MRO's next business day. In the MRO's sole discretion, a determination will be made as to whether a result is positive or negative.

Pursuant to DOT regulations, individual test results for driver/applicants and drivers will be released to the District and will be kept strictly confidential unless consent for the release of the test results has been obtained. Any individual who has submitted to drug testing in compliance with this policy is entitled to receive the results of such testing upon timely written request.

An individual testing positive may make a request of the MRO to have the secondary vial tested. The driver may request that the secondary vial be tested by a different SAMHSA-certified lab than tested the primary specimen. The individual making the request for a test of the second specimen must prepay all costs associated with the test. The request for testing of a second specimen is timely if it is made to the MRO within seventy-two (72) hours of the individual being notified by the District of a positive test result.

Alcohol Tests

The District will perform alcohol tests using an evidential breath-testing device. The District may provide use of an evidential breath-testing device through a vendor or agent. The driver shall report to the site of an evidential breath-testing device as notified by the District. The evidential breath-testing device will be operated by a breath alcohol technician. The driver shall follow all instructions given by the breath alcohol technician. In the event that a driver, on the basis of the evidential breath test, has a blood alcohol content of .02 to .0399, the driver shall be removed from duty for twenty-four (24) hours or until his/her next scheduled on-duty time, whichever is longer. Applicants are not medically qualified until after the twenty-four (24) hour time frame expires. Drivers with tests indicating a blood alcohol concentration of .04 or greater are considered to have engaged in prohibited conduct. All alcohol tests shall be performed just prior to, during, or just after performance of a safety-sensitive function.

Training

The District shall ensure supervisors designated to determine whether reasonable suspicion exists to require a driver to undergo testing under 49 C.F.R. 382.307 receive at least sixty (60) minutes of training on alcohol misuse and receive at least an additional sixty (60) minutes of training on controlled-substances use. The training shall cover the physical, behavioral, speech, and performance indicators of probable alcohol misuse and use of controlled substance.

The District shall provide educational materials that explain the requirements of 49 C.F.R. 382.601, consequences of violating the regulations, and the employer's policies and procedures with respect to meeting these requirements. The materials supplied to drivers may include information on additional employer policies with respect to the use or possession of alcohol or controlled substances, for example, the consequences for a driver found to have a specified alcohol or controlled-substances level based on the employer's authority independent of 49 C.F.R. 382.601. The District shall ensure each driver is required to sign a statement certifying that he/she has received a copy of these materials described in 49 C.F.R. s 382.601.

Legal Reference: 49 C.F.R. 40.3
49 C.F.R. 382.307
49 C.F.R. 382.601

Approved 11-18-02 Reviewed _____ Revised _____

HASTINGS PUBLIC SCHOOLS

Personnel - All EmployeesDrug and Substance Use and Abuse

It is the policy of the Hastings Public School District to eliminate the influence of drugs, alcohol and other chemicals within the school environment and to educate students against the usage of drugs, alcohol and illegal substances. The District will implement regulations and practices which will ensure compliance with laws relating to drugs and alcohol, including: the Drug-Free Workplace Act and the Omnibus Transportation Employee Testing Act of 1991, and all regulations and rules promulgated pursuant thereto.

Section 1 Drug-Free Workplace

The District has established the school as a drug-free workplace. The drug-free workplace for this purpose includes school grounds, school utilized vehicles, and places in which school activities are held. The school district recognizes that the use, possession, or being under the influence of illicit drugs or alcohol constitutes a hazard to the positive development of students and employees and a substantial interference with school purposes.

1. The unlawful manufacture, distribution, disposition, possession, or use of a controlled substance is prohibited in the work place. Employees are also prohibited from possessing, using or distributing illicit drugs or alcohol, or being under the influence of illicit drugs or alcohol, on any district property or district sponsored event. Any level of impairment from illicit drugs, alcohol, or inhalants, and the presence of any odor of illicit drugs (such as marijuana) or alcohol in the work place or on duty time shall be a violation of the drug-free workplace.
2. The possession or distribution of a look-alike drug or look-alike controlled substance is prohibited. In addition, employees are expected to serve as role models for students and will be considered to have violated the District's expectations in the event the employee commits a criminal drug or alcohol offense off the work place or off duty time.
3. As a condition of employment, employees will abide by the District's drug-free workplace policies and notify the Superintendent or designee in writing of any criminal drug statute conviction for a violation occurring in the workplace no later than five (5) calendar days after such conviction.
4. Disciplinary sanctions, up to and including termination of employment and referral for prosecution, will be imposed upon employees who violate the aforementioned standards of conduct. Sanctions for violation thereof may include the requirement that the employee complete an appropriate rehabilitation program, reprimands, and non-renewal, cancellation, or termination of contract of employment.

5. Employees shall be advised through employee publications about drug and alcohol counseling and rehabilitation and reentry programs that are available.
6. Employees shall be furnished with a paper or digital copy of this policy.

This policy supplements and is in addition to all other policies, regulations, practices, procedures and contractual provisions regarding or related to the improper or unlawful possession, use, or distribution of illicit drugs and alcohol.

Section 2 Alcohol and Drug Testing

The District will implement regulations and practices which will insure compliance with the Omnibus Transportation Employee Testing Act of 1991, the Moving Ahead for Progress in the 21st Century (MAP-21) Act, and all regulations and rules promulgated pursuant to such Acts. Employees in "safety-sensitive" positions, as defined by the Act and regulations promulgated thereunder, including employees whose position requires a commercial driver's license (CDL), shall be tested for alcohol and controlled substances as required by law. (See attached Appendix "1"). Refusal to submit to such pre-employment testing, or testing positive, shall disqualify an applicant from employment. Reasonable suspicion, random, post-accident, return-to-duty, and follow-up testing shall also be conducted. Employees who test positive shall be immediately removed from safety-sensitive positions and shall be removed from employment.

Legal Reference: 41 U.S.C. §§701 to 707
49 U.S.C. §§5331(b) and 31306; 49 CFR Part 382

Approved: 11/18/2002
Reviewed: 06/13/2022
Revised: _____

HASTINGS PUBLIC SCHOOLS

Policy 404.07 - APPENDIX 1

**CONTROLLED SUBSTANCES AND ALCOHOL USE AND TESTING:
FEDERAL REGULATIONS, HASTINGS PUBLIC SCHOOLS' COMPLIANCE
POLICIES AND PROCEDURES, AND EDUCATIONAL MATERIALS**

The U.S. Department of Transportation (DOT) and the Federal Highway Administration (FHWA) have issued regulations requiring that individuals who perform safety-sensitive functions and who are required to maintain a commercial driver's license (CDLs) be tested for controlled substances and alcohol and not engage in controlled substances use or alcohol misuse. Information concerning those regulations, Hastings Public Schools policies and procedures, and educational materials relating to controlled substances use and alcohol misuse is set forth as follows:

(A) The persons designated by Hastings Public Schools to answer employee questions about these materials are:

Superintendent of Schools
Secondary Principal

(B) The categories of employees who are subject to the provisions of the federal controlled substances and alcohol use and testing regulations are:

Individuals who perform safety-sensitive functions and who are required to maintain a commercial driver's license (CDLs), including bus drivers and distribution and maintenance employees who are subject to driving commercial motor vehicles.

(C) The term "safety-sensitive functions" means:

- (1) All time waiting to be dispatched, unless the driver has been relieved from duty;
- (2) All time inspecting equipment or inspecting, servicing, or conditioning any commercial motor vehicle (i.e., a vehicle in excess of 26,000 pounds GVWR or designed to carry 16 or more passengers, including the driver) at any time;
- (3) All driving time (i.e., time spent at the controls of a commercial motor vehicle in operation);
- (4) All time, other than driving time, in or upon any commercial motor vehicle;
- (5) All time loading or unloading a vehicle, supervising, or assisting in the loading or unloading, attending a vehicle being loaded or unloaded, remaining in readiness to operate the vehicle, or in giving or receiving receipts for shipments loaded or unloaded;
- (6) All time spent performing the driver requirements of 49 CFR §§392.40 and 392.41 relating to accidents;
- (7) All time repairing, obtaining assistance, or remaining in attendance upon a disabled vehicle.

(D) **Employee conduct that is prohibited by the federal controlled substances and alcohol use and testing regulations includes:**

1. **Alcohol concentration.**
No driver shall report for duty or remain on duty requiring the performance of safety-sensitive functions while having an alcohol concentration of 0.04 or greater.
2. **Alcohol possession.**
No driver shall be on duty or operate a commercial motor vehicle while the driver possesses alcohol.
3. **On-duty use.**
No driver shall use alcohol while performing safety-sensitive functions.
4. **Pre-duty use.**
No driver shall perform safety-sensitive functions within four (4) hours after using alcohol.
5. **Use following an accident.**
No driver required to take a post-accident alcohol test shall use alcohol for eight hours following the accident, or until the driver undergoes a post-accident alcohol test, whichever occurs first.
6. **Refusal to submit to a required alcohol or controlled substances test.**
No driver shall refuse to submit to a post-accident alcohol or controlled substances test, a reasonable suspicion alcohol or controlled substance test, or a follow-up alcohol or controlled substances test.
7. **Controlled substances use.**
No driver shall report for duty or remain on duty requiring the performance of safety-sensitive functions when the driver uses any controlled substance, except when the use is pursuant to the instructions of a physician who has advised the driver that the substance does not adversely affect the driver's ability to safely operate a commercial motor vehicle.
8. **Controlled substances test.**
No driver shall report for duty, remain on duty or perform a safety-sensitive function, if the driver tests positive for controlled substances.

(E) **The circumstances under which an employee will be tested for alcohol and/or controlled substances pursuant to the federal regulations include:**

1. **Pre-employment testing.**
Prior to the first time a driver performs safety-sensitive functions, the driver shall undergo testing for alcohol and controlled substances. No safety-sensitive functions are to be performed unless the driver has been administered an alcohol test with a result indicating an alcohol concentration less than 0.04, and has received a controlled

substances test result from the medical review officer indicating a verified negative test result.

2. **Post-accident testing.**

(a) As soon as practicable following an accident involving a commercial motor vehicle, each surviving driver:

(1) Who was performing safety-sensitive functions with respect to the vehicle, if the accident involved the loss of human life; or

(2) Who receives a citation under State or local law for a moving traffic violation arising from the accident shall undergo a test for alcohol and controlled substances.

(b) (1) *Alcohol tests.* Shall be administered within two hours following the accident unless such cannot reasonably be done, and not more than eight hours following the accident.

(2) *Controlled substance tests.* Shall be administered within 32 hours following the accident.

(c) A driver who is subject to post-accident testing shall remain readily available for such testing or may be deemed by the employer to have refused to submit to testing. The driver shall be permitted to leave the immediate scene of an accident for the period necessary to obtain assistance in responding to the accident, or to obtain necessary emergency medical care, but shall otherwise remain readily available for testing.

3. **Random testing.**

(a) Drivers shall be subject to random testing. The minimum annual percentage rate for random alcohol testing should be 25 percent of the average number of driver positions, or such minimum annual percentage rate as established from time to time by the FHWA. The minimum annual percentage rate for random controlled substance testing shall be 50 percent of the average number of driver positions.

(b) The selection of drivers for random alcohol and controlled substances testing shall be made by a scientifically valid method. Under the selection process used, each driver shall have an equal chance of being tested each time selections are made.

(c) The random alcohol and controlled substances tests shall be unannounced and the dates for administering random alcohol and controlled substances tests shall be spread reasonably throughout the calendar year.

(d) Each driver who is notified of selection for random alcohol and/or controlled substances testing shall proceed to the test site immediately; provided, however, that if the driver is performing a safety-sensitive function at the time of notification, the driver shall cease to perform the safety-sensitive function and proceed to the testing site as soon as possible.

4. **Reasonable suspicion testing.**
 - (a) A driver shall submit to an alcohol test when the employer has reasonable suspicion to believe that the driver has engaged in conduct prohibited by the federal drug and alcohol testing regulations (except for possession of alcohol).
 - (b) Under federal law, notwithstanding the absence of a reasonable suspicion alcohol test, a driver is prohibited from reporting for duty or remaining on duty requiring the performance of safety-sensitive functions while the driver is under the influence of or impaired by alcohol and must not perform or continue to perform safety-sensitive functions, until:
 - (i) An alcohol test is administered and the driver's alcohol concentration measures less than 0.02; or
 - (ii) Twenty-four hours have elapsed following the determination that there is reasonable suspicion to believe that the driver has violated the prohibitions concerning the use of alcohol.

5. **Return-to-duty testing.**
 - (a) Alcohol. If a driver has engaged in conduct prohibited by the federal drug and alcohol testing regulations concerning alcohol and has not been terminated, the driver shall undergo a return-to-duty alcohol test with a result indicating an alcohol concentration of less than 0.02.
 - (b) Controlled Substances. If a driver has engaged in conduct prohibited by the federal drug and alcohol testing regulations concerning controlled substances, and has not been terminated, the driver shall undergo a return-to-duty controlled substances test with a result indicating a verified negative result for controlled substances use.

6. **Follow-up testing.**

Following a determination that a driver is in need of assistance in resolving problems associated with alcohol misuse and/or use of controlled substances, the driver shall, if still employed, be subject to unannounced follow-up alcohol and/or controlled substances testing as directed by a substance abuse professional in accordance with the provisions of federal regulations.

Random, reasonable suspicion, and follow-up alcohol testing shall be conducted only when the driver is performing safety-sensitive functions, just before the driver is to perform safety-sensitive functions, or just after the driver has ceased performing safety-sensitive functions.

(F) The procedures that will be used to test for the presence of alcohol and controlled substances, to protect the employee and the integrity of the testing processes, to safeguard the validity of the test results, and to ensure that those results are attributed to the correct employee include:

The procedures outlined in 49 CFR 40, concerning procedures for Transportation Workplace Drug and Alcohol Testing Program, will be followed. This includes use of a "split sample" approach for drug testing and chain of custody procedures including documentation of screening aliquots.

(G) An employee is required to submit to alcohol and controlled substances tests administered pursuant to the federal regulations.

(H) A "refusal to submit" to an alcohol or controlled substance test includes:

Refuse to submit (to an alcohol or controlled substances test) means that a driver

(1) Fails to provide adequate breath for testing without a valid medical explanation after he or she has received notice of the requirement for breath testing, (2) fails to provide adequate urine for controlled substances testing without a valid medical explanation after he or she has received notice of the requirement for urine testing, or (3) engages in conduct that clearly obstructs the testing process. A failure to remain readily available for post-accident testing, or to notify the employer of the need for such testing, or to proceed to the test site immediately for random testing, may be deemed by the employer to constitute a refusal to submit.

The consequences for refusing to submit to an alcohol or controlled substances test are as follows: A driver who has refused to submit to a required alcohol or controlled substance test is subject to the same consequences as a driver who has tested positive on an alcohol (concentration of 0.04 or greater) or controlled substances test.

(I) The consequences under the federal regulations for employees who have violated the federal regulations relating to controlled substances and alcohol use and testing include:

The driver shall be removed from and not permitted to perform safety-sensitive functions. The driver shall be referred for evaluation by a substance abuse professional for a determination of what assistance, if any, the employee needs in resolving problems associated with alcohol misuse and controlled substances abuse.

Before a driver returns to duty requiring the performance of a safety-sensitive function after engaging in conduct prohibited by the federal regulations, the driver shall, if still employed, undergo a return-to-duty alcohol test with a result indicating an alcohol concentration of less than 0.02 if the conduct involved alcohol, or a controlled substances test with a verified negative result if the conduct involved a controlled substance.

In addition, each driver identified as needing assistance in resolving problems associated with alcohol misuse or controlled substance use, if still employed,

- (i) Shall be evaluated by a substance abuse professional to determine that the driver has properly followed any rehabilitation program prescribed, and
- (ii) Shall be subject to unannounced follow-up alcohol and controlled substances tests administered by the employer following the driver's

return to duty.

The driver may also be subject to the penalty provisions of 49 U.S.C. § 521(b).

(J) The consequences under the federal regulations for employees found to have an alcohol concentration of 0.02 or greater but less than 0.04 include: Removal from safety-sensitive functions for a period of not less than 24 hours following administration of the test.

(K) Information to assist employees in avoiding alcohol misuse and controlled substances use, signs and symptoms of an alcohol or a controlled substances problem, and available methods of intervening when such a problem is suspected:

Information will be made available by the counselor to employees upon request.

Approved: 11/18/2002

Reviewed: 06/13/2022

Revised:

HASTINGS PUBLIC SCHOOLS

STUDENTS WITH DISABILITIES

Special Education

Hastings Public Schools adopts this special education policy with the intent that the policy maintain the District's compliance with all applicable laws affecting special education services and programs. The Superintendent or designees shall develop regulations or procedures to implement these policies. Employees and contractors of the District are expected to comply with these policies and all regulations, guidelines and procedures related to this policy in all respects.

The District will abide by all state and federal laws relating to special education. The District's special education policy and regulations, guidelines and procedures related to this policy are to be interpreted so as to be in compliance with such laws. In the event of changes in law, the school administration shall be authorized to implement modifications of practice to comply with such changes (whether the changes impose more or less stringent procedural or substantive requirements) until such time as amended policies are adopted by the Board of Education. References herein to 92 NAC 51 citations are made to Rule 51 as in effect on the date of the adoption of these policies. In the event of renumbering or other revisions to Rule 51, the policy shall be interpreted and implemented consistent with such renumbering or revisions.

1. Free Appropriate Public Education

A free appropriate public education shall be made available to all children with disabilities residing in the District from date of diagnosis through the school year in which the student reaches 21 years of age, including children with disabilities who have been suspended or expelled.

Legal Reference: 92 NAC 51-004.01 through 004.03A and 007.07C2 through 007.07C6

2. Full Educational Opportunity Goal

The District shall take steps to ensure that its children with verified disabilities have available to them the variety of educational programs and services available to children without disabilities in the areas served by the District, including art, music, industrial arts, family consumer science education, and vocational education.

Legal Reference: 92 NAC 51-004.11A

3. Child Find

All children with disabilities residing in the District, including children with disabilities who are homeless or are wards of the state or attending nonpublic schools, regardless of the severity of their disabilities, who are in need of special education and related services, will be identified, located and evaluated and a practical method shall be developed and implemented by the administration to determine which children with disabilities are currently receiving needed special education and related services.

Legal Reference: 92 NAC 51-006.01 through 006.01A2

4. Individualized Education Program (IEP)

An individualized education program, or an individualized family service plan, is to be developed, reviewed, and revised for each child with a disability in accordance with 92 NAC 51-007.

Legal Reference: 92 NAC 51-007

5. Least Restrictive Environment

To the maximum extent appropriate, children with disabilities, including children in public or private institutions or other care facilities, are to be educated with children who are not disabled, and special classes, separate schooling, or other removal of children with disabilities from the regular educational environment will occur only when the nature or severity of the disability of a child is such that education in regular classes with the use of supplementary aids and services cannot be achieved satisfactorily.

Legal Reference: 92 NAC 51-008.01 through 008.011

6. Procedural Safeguards

Children with disabilities and their parents shall be afforded the required procedural safeguards.

Legal Reference: 92 NAC 51-009.01 through 009.07; 009.10 through 009.12; 009.14, 006.07 and 016.01 through 016.07C

7. Evaluation and Identification Procedures

Children with disabilities shall be evaluated and identified in accordance with 92 NAC 51-006. The District will respond to a request for an Independent Educational Evaluation without unnecessary delay. Locations of any evaluator shall be within a reasonable distance of the District. A reasonable distance means within 100 miles of the school building the child attends and within Nebraska. In the event this geographic area restriction would prevent a parent from obtaining an Independent Educational Evaluation, the location of the evaluator may be outside the specified geographic area but must be within Nebraska. The District will provide the parent(s) with a list of qualified agencies/evaluators within the geographic area. The evaluators are to have their rates approved by the Nebraska Department of Education to be authorized to conduct the evaluation.

Legal Reference: 92 NAC 51-006

8. Confidentiality of Personally Identifiable Information

The confidentiality of student records and information shall be maintained in accordance with law.

Legal Reference: 92 NAC 51-003.16, 003.20, 009.03 through 009.03M3

9. Transition of Children from Part C to Preschool Programs

Children participating in early intervention programs under Part C of the IDEA (early intervention services) and who will participate in preschool programs assisted under Part B of the IDEA (services for school-aged children) shall experience a smooth and effective transition to those preschool programs in a manner consistent with 92 NAC 52-008. The District will participate in transition planning conferences arranged by the designated lead agency.

Legal Reference: 92 NAC 52-008

10. Children in Nonpublic Schools

To the extent consistent with the number and location of children with disabilities in the District who are enrolled by their parents in nonpublic elementary and secondary schools in the District, provision will be made for the participation of those children in the programs assisted or carried out under Part B of the IDEA (services for school-aged children) by providing them with special education and related services.

Legal Reference: 92 NAC 51-012.08 and 015

11. Personnel Standards and Personnel Development

Personnel providing special education or related services to children with disabilities shall be appropriately and adequately prepared and trained in accordance with IDEA requirements and the District will take measurable steps to recruit, hire, train and retain personnel meeting the requirements of IDEA to provide such services.

Legal Reference: 92 NAC 51-010

12. Participation in and Reporting of State and District Wide Assessments

All children with disabilities shall be included in all general state and district wide assessment programs, including assessments described under section 612(a)(16)(A) of the IDEA with appropriate accommodations and alternate assessments where necessary and as indicated in their respective individualized education programs. The District will make available to the Nebraska Department of Education the information necessary to carry out its duties relating to the reporting of children with disabilities participation in assessments.

Legal Reference: 92 NAC 51-004.05

13. Suspension and Expulsion Rates

The District will examine data, including data disaggregated by race and ethnicity, to determine if significant discrepancies are occurring in the rate of long-term suspensions and expulsions of children with disabilities.

Legal Reference: 92 NAC 51-004.06E

14. Access to Instructional Materials

As part of any print instructional materials adoption process, procurement contract, or other practice or instrument used for purchase of print instructional materials, the District will enter into a written contract with the publisher of the print instructional materials to:

1. Require the publisher to prepare and, on or before delivery of the print instructional materials, provide to the National Instructional Material Access Center, electronic files containing the contents of the print instructional materials using the National Instructional Materials Accessibility Standard, or
2. Purchase instructional materials from the publisher that are produced in, or may be rendered in specialized formats.

Legal Reference: 92 NAC 51-004.15

15. Over-Identification and Disproportionality

Procedures shall be in place to ensure that testing and evaluation materials and procedures utilized for the evaluation and placement of children with disabilities will be selected and administered so as not to be racially or culturally discriminatory. Such materials or procedures shall be provided and administered in the child's native

language or mode of communication, unless it is clearly not feasible to do so, and no single procedure shall be the sole criterion for determining an appropriate educational program for a child.

Legal Reference: 92 NAC 51-003.10; 006.02C

16. Prohibition on Mandatory Medication

Children shall not be required to obtain a prescription for a controlled substance as a condition of attending school, receiving an evaluation to determine whether a child has a disability or the nature and extent of special education and related services the child needs, or receiving special education services.

Legal Reference: 92 NAC 51-004.11D; 21 U.S.C. §812(c)

17. Transportation

Transportation will be provided for children with disabilities who are eligible for transportation and residents of the school district as required by law.

Legal Reference: 92 NAC 51-014.01 through 014.02

18. Surrogates

A surrogate will be appointed and other action taken to ensure the rights of children with a disability as required by law.

Legal Reference: 92 NAC 51-009.10

19. Early Intervention Services – Consent

When a parent refuses to provide consent under 92 NAC 52, a meeting will be held or offered to explain to the parents how their failure to consent affects the ability of their child to receive services under 92 NAC 52.

Legal Reference: 92 NAC 52

Legal Reference: 34 CFR Parts 300, 303 and 304
Neb. Rev. Stat. Sec. 79-1110 to
79-116792 NAC 51

Approved: 02/16/2004

Reviewed: 04/17/2006, 06/15/2009, 05/10/2021

Revised: 05/15/2006, 06/15/2009, 06/14/2021

HASTINGS PUBLIC SCHOOLS

STUDENTS WITH DISABILITIESSpecial Education

Hastings Public Schools adopts this special education policy with the intent that the policy maintains the District's compliance with all applicable laws affecting special education services and programs. The Superintendent or designees shall develop regulations or procedures to implement these policies. Employees and contractors of the District are expected to comply with these policies and all regulations, guidelines and procedures related to this policy in all respects.

The District will abide by all state and federal laws relating to special education. The District's special education policy and regulations, guidelines and procedures related to this policy are to be interpreted so as to be in compliance with such laws. In the event of changes in law, the school administration shall be authorized to implement modifications of practice to comply with such changes (whether the changes impose more or less stringent procedural or substantive requirements) until such time as amended policies are adopted by the Board of Education. References herein to 92 NAC 51 citations are made to Rule 51 as in effect on the date of the adoption of these policies. In the event of renumbering or other revisions to Rule 51, the policy shall be interpreted and implemented consistent with such renumbering or revisions.

1. Free Appropriate Public Education

A free appropriate public education shall be made available to all children with disabilities residing in the District, including children with disabilities who have been suspended or expelled, from date of verification through the school year in which the child is no longer eligible or the student reaches twenty-one (21) years of age, whichever occurs earlier. An Individualized Education Plan ("IEP") will be created for each such child that will enable the student to make progress appropriate in light of the student's unique circumstances

Legal Reference: 92 NAC 51-004.01 through 004.03A and 007.07C2 through 007.07C6

2. Full Educational Opportunity Goal

The District shall take steps to ensure that its children with verified disabilities have available to them the variety of educational programs and services available to children without disabilities in the areas served by the District, including art, music, industrial arts, family consumer science education, and vocational education.

Legal Reference: 92 NAC 51-004.11A

3. Child Find

All children from birth to age twenty-one (21) with disabilities residing in the District, including children with disabilities who are homeless or are wards of the state or attending nonpublic schools, regardless of the severity of their disabilities, who are in need of special education and related services, will be identified, located and evaluated. A practical method shall be developed and implemented by the administration to determine which children with disabilities are currently receiving needed special education and related services. The District will implement multiple methods to provide

parents, guardians, and community members with information regarding how to refer a child for an evaluation and the identification process and will publish an annual notice of any significant activity that is designed to identify, locate, or evaluate children to publicly notify parents, guardians, or appointed surrogates. The District's child find process will be consistent with Federal and Nebraska regulations. Legal Reference: 92 NAC 51-006.01 through 006.01A2

4. Pre-Referral Interventions

For a school age student, a general education student assistance team (SAT) or a comparable problem solving team shall be used prior to referral for multidisciplinary team evaluation. The SAT or comparable problem solving team shall utilize and document problem solving and intervention strategies to assist the teacher in the provision of general education. If the student assistance team or comparable problem solving team feels that all viable alternatives have been explored, a referral for multidisciplinary evaluation shall be completed. A referral shall include information from the SAT or comparable problem solving team, meeting the requirements of 92 NAC 51-006.01B and a listing of the members of the SAT or comparable problem solving team.

Legal Reference: 92 NAC 51-006.01B

5. Disability Verification and Eligibility

Eligibility for services will be determined by a multidisciplinary team based on the results of a comprehensive evaluation. The multidisciplinary team will identify whether a child is eligible for special education services based on the disability categories identified by Nebraska and Federal regulations. The multidisciplinary team will rule out the determinant factor is due to a lack of appropriate instruction in reading or math or due to lack of English proficiency. The team will prepare a written report documenting all evaluation findings in accordance with Federal and Nebraska requirements that will be provided to the parent, guardian, or appointed surrogate. When a child is not eligible for services, the multidisciplinary team will determine if general education interventions or strategies are needed.

Legal Reference: 92 NAC 51-006.03; 92 NAC 51-006.04B through 006.04N;

6. Individualized Education Program (IEP)

An individualized education program, or an individualized family service plan, is to be developed, reviewed, and revised for each child with a disability in accordance with 92 NAC 51-007 by teams that will include all roles identified within Federal and Nebraska rules. Any draft of an IEP that is developed will not be considered final until it is reviewed and revised based on the team, including the parent, guardian, or appointed surrogate, input, and consensus. The district will make reasonable efforts to obtain informed consent from the parent, guardian, or appointed surrogate for special education placement on the IEP form before services are initiated. Revocation of consent for services must be documented by the parent, guardian, or appointed surrogate in writing.

Legal Reference: 92 NAC 51-007

7. Least Restrictive Environment

To the maximum extent appropriate, children with disabilities, including children in public or private institutions or other care facilities, are to be educated with children who are not

disabled. Placement for a student with a disability will be based upon a completed IEP developed by a group of persons, including the parent, guardian, or appointed surrogate, knowledgeable about the child, the meaning of the evaluation data, and the placement options. Special classes, separate schooling, or other removal of children with disabilities from the regular educational environment will occur only when the nature or severity of the disability of a child is such that education in regular classes with the use of supplementary aids and services cannot be achieved satisfactorily (the “Least Restrictive Environment Rules”). The District will ensure that a continuum of alternative placements is available to meet the needs of children with disabilities, particularly those in disproportionate groups, for special education and related services.

Legal Reference: 92 NAC 51-008.01

8. Procedural Safeguards

Children with disabilities and their parents, guardians, or appointed surrogates shall be afforded the required procedural safeguards. Parents, guardians, and appointed surrogates will be given a copy of their procedural safeguards annually or upon initial referral or parental (parent, guardian, or appointed surrogate) request for evaluation; upon request by a parent, guardian, or appointed surrogate; upon receipt by the school district or approved cooperative of the first occurrence of the filing of a complaint under 92 NAC 51-009.11 and the first occurrence of filing a special education due process case under 92 NAC 55; and in accordance with the discipline procedures in 92 NAC 51-016.

Legal Reference: 92 NAC 51-009.01 through 009.07; 009.10 through 009.12; 009.14, 006.07

9. Disciplinary Removal of Children with Disabilities

School personnel may remove a child with a disability who violates a code of student conduct from his or her current placement to an appropriate interim alternative educational setting, another setting, or suspension, for no more than ten (10) consecutive school days and for additional removals of not more than ten (10) consecutive school days in the same school year for separate incidents of misconduct, as long as those removals do not constitute a change of placement. If a student with a disability violates a code of student conduct, the school district will ensure that school personnel appropriately consider unique circumstances on a case-by-case basis when determining whether a change in placement, as defined in Federal and Nebraska rules, is appropriate for the student. Change of placement decisions related to disciplinary removals will be consistent with Federal and Nebraska regulations. For disciplinary changes in placement that would exceed ten (10) consecutive school days, if the behavior that gave rise to the violation of the school code is determined not to be a manifestation of the child’s disability, school personnel may apply the relevant disciplinary procedures to children with disabilities in the same manner and for the same duration as the procedures that would be applied to children without disabilities.

Legal Reference: 92 NAC 51-016

10. Evaluation, Identification, and Reevaluation Procedures

Children with disabilities shall be evaluated, identified, and reevaluated by a team of multidisciplinary qualified professionals in accordance with 92 NAC 51-006. The MDT of a child suspected of having a specific learning disability shall include the additional

requirements in accordance with 92 NAC 51-006.04K. The District will make reasonable efforts to obtain written permission for evaluation in accordance with Federal and Nebraska rules. Revocation for consent for evaluation must be documented by the parent, guardian, or appointed surrogate in writing.

The documented results of the evaluation will be provided to parent, guardian, or appointed surrogate and included in student files. All evaluation components will be at district expense. The District will utilize a variety of assessment instruments to ensure district teams have access to appropriate measures to complete evaluations. The district will follow any publisher guidelines for assessments and will not use outdated or culturally inappropriate tools.

The District will respond to a request for an Independent Educational Evaluation without unnecessary delay. The parent, guardian, or appointed surrogate will be given written notice of the District's decision to either move forward with the Independent Educational Evaluation or to initiate a hearing to determine the appropriateness of the evaluation. If the District agrees to move forward with the evaluation, locations of any evaluator shall be within a reasonable distance of the District. A reasonable distance means within 100 miles of the school building the child attends and within Nebraska. In the event this geographic area restriction would prevent a parent, guardian, or appointed surrogate from obtaining an Independent Educational Evaluation, the location of the evaluator may be outside the specified geographic area but must be within Nebraska. The District will provide the parent, guardian, or appointed surrogate with a list of qualified agencies/evaluators within the geographic area. The evaluators are to have their rates approved by the Nebraska Department of Education to be authorized to conduct the evaluation.

Legal Reference: 92 NAC 51-006

11. Confidentiality of Personally Identifiable Information

A system of safeguards will be implemented to protect the confidentiality of student records and information in accordance with law.

Legal Reference: 92 NAC 51-003.16, 003.20, 009.03 through 009.03M3

12. Transition of Children from Part C to Preschool Programs

Children participating in early intervention programs under Part C of the IDEA (early intervention services) will be appropriately evaluated, identified, and have services under Part B of the IDEA by age 3 in a manner consistent with 92 NAC 52-008. Children receiving early intervention services under Part C of the IDEA may continue to receive Part C services, upon parental consent, until the August 31st following the child's third birthday. The District will participate in transition planning conferences arranged by the designated lead agency.

Legal Reference: 92 NAC 52-008

13. Children in Nonpublic Schools

To the extent consistent with the number and location of children with disabilities in the District who are enrolled by their parents, guardians, or appointed surrogates in nonpublic elementary and secondary schools in the District, provision will be made for the participation of those children in the programs assisted or carried out under Part B of the

IDEA (services for school-aged children) by providing them with special education and related services.

Legal Reference: 92 NAC 51-012.08 and 015

14. Personnel Standards and Personnel Development

Personnel providing special education or related services to children with disabilities shall be appropriately and adequately prepared and trained in accordance with IDEA requirements and the District will take measurable steps to recruit, hire, train and retain personnel meeting the requirements of IDEA to provide such services.

Legal Reference: 92 NAC 51-010

15. Participation in and Reporting of State and District Wide Assessments

All children with disabilities shall be included in all general state and district wide assessment programs, including assessments described under section 612(a)(16)(A) of the IDEA with appropriate accommodations and alternate assessments where necessary and as indicated in their respective individualized education programs. The District will make available to the Nebraska Department of Education the information necessary to carry out its duties relating to the reporting of children with disabilities participation in assessments.

Legal Reference: 92 NAC 51-004.05

16. Suspension and Expulsion Rates

The District will examine data, including data disaggregated by race/ethnicity, gender, LEP status, and disability category, to determine if significant discrepancies are occurring in the rate of long-term suspensions and expulsions of children with disabilities.

Legal Reference: 92 NAC 51-004.06E

17. Access to Instructional Materials

As part of any printed instructional materials adoption process, procurement contract, or other practice or instrument used for purchase of printed instructional materials, the District will enter into a written contract with the publisher of the printed instructional materials to:

- A. Require the publisher to prepare and, on or before delivery of the print instructional materials, provide to the National Instructional Material Access Center, electronic files containing the contents of the printed instructional materials using the National Instructional Materials Accessibility Standard, or
- B. Purchase instructional materials from the publisher that are produced in, or may be rendered in specialized formats.

Legal Reference: 92 NAC 51-004.15

18. Over-Identification and Disproportionality

Procedures shall be in place to ensure that testing and evaluation materials and procedures utilized for the evaluation and placement of children with disabilities will be selected and administered so as not to be racially or culturally discriminatory. Such materials or procedures shall be provided and administered in the child's native language or mode of communication, unless it is clearly not feasible to do so, and no single procedure shall be the sole criterion for determining an appropriate educational program

for a child. All District special education provisions will be equitably available to all children regardless of race, ethnicity, language, location, transience, income level, and access to medical care.

Legal Reference: 92 NAC 51-006.02C

19. Prohibition on Mandatory Medication

Children shall not be required to obtain a prescription for a controlled substance as a condition of attending school, receiving an evaluation to determine whether a child has a disability or the nature and extent of special education and related services the child needs, or receiving special education services.

Legal Reference: 92 NAC 51-004.11D; 21 U.S.C. §812(c)

20. Transportation

Transportation will be provided for children with disabilities who are eligible for transportation and residents of the school district as required by law to access academic, related services, and nonacademic services and activities as determined by the child's IEP. Except when a parent is transporting only his or her child, the District shall require that the driver and vehicle meet the standards required by 92 NAC 91 and 92.

Legal Reference: 92 NAC 51-014.01 through 014.02

21. Surrogates

A surrogate will be appointed, and other action taken to ensure the rights of children with a disability as required by law. The surrogate may represent the child in all matters related to the identification, evaluation, and educational placement of a child and the provision of a free appropriate public education to the child.

Legal Reference: 92 NAC 51-009.10

22. Early Intervention Services – Consent

When a parent refuses to provide consent under 92 NAC 52, a meeting will be held or offered to explain to the parents how their failure to consent affects the ability of their child to receive services under 92 NAC 52.

Legal Reference: 92 NAC 52

Legal Reference: 34 CFR Parts 300, 303 and 304
Neb. Rev. Stat. Sec. 79-1110 to 79-1167
92 NAC 51, 52 and 53

Approved: 02/16/2004
Reviewed: 04/17/2006, 06/15/2009, 05/10/2021, 06/13/2022
Revised: 05/15/2006, 06/15/2009, 06/14/2021,

HASTINGS PUBLIC SCHOOLS

1.1 Purpose and Scope.

The Hastings Public Schools (hereinafter referred to as "HPS") has prepared the following Request for Proposal (RFP) document for the procurement of a new sound and lighting system at Hastings High School located at:

Hastings High School
1100 W. 14th Street
Hastings, NE
68901

HPS seeks a quality vendor with capabilities to provide responsive service for the Hastings High School project. The lighting and sound system must meet open industry standards, and meet the requirements established by the HPS as described on the following pages.

The system is to be completed and operational by **September 1st, 2022**.

This RFP sets forth:

1. The process whereby invited parties may respond.
2. Instructions regarding the required form and content of vendor proposals.
3. The functional and performance criteria for required system and hardware.

Upon completion of the RFP process, the HPS may contract with selected vendor to provide the system and hardware. The successful response will include solutions for the proper management, maintenance and monitoring of the system. The selected vendor will be responsible for all design work, planning, maintenance, and training in operating the new system.

1.2 Communications Regarding RFP.

1.2.1 Proposal Response Deadline and Delivery. Vendors shall provide one signed original. Proposals must be received at the following 1924 West A Street Hastings, NE 68901 address no later than **June 8th, 2022 by 2:00 pm. The awarding of the contract will take place on June 14th, 2022**. Vendors are solely responsible for ensuring that proposals delivered on time. Delays caused by any delivery service, including the US Postal Service, will not be grounds for an extension of the deadline. Proposals submitted after the deadline may be rejected. Proposals may be sent via E-Mail or Fax.

Mr. Trent Kelly
1924 W A. Street
Hastings, NE. 68901
Fax - 402-461-7506
Email - trent.kelly@hpstigers.org

1.2.2 Contacts. Upon release of this RFP all vendor communications concerning this project shall be directed to:

Mr. Trent Kelly
1924 W A. Street
Hastings, NE. 68901
Email - trent.kelly@hpsstigers.org
Phone 402-469-2094

Mr. Christian Yost
1100 West 14th St.
Hastings, NE. 68901
christian.yost@hpsstigers.org
Phone 402-690-9978

Vendors who seek information, clarification, or interpretations from the HPS staff are advised that such material is used at the vendor's own risk and HPS shall not be bound by any such representation.

1.2.3 Vendor Clarifications and Questions. Questions concerning the RFP must be submitted in writing (may be faxed or sent via E-mail) in advance of the RFP due date.

1.2.4 RFP Changes or Amendments. Any revisions to the RFP will be issued in the form of an addendum and will be distributed to all vendors prior to the Response Due Date.

1.2.5 Clarifications. HPS reserves the right to obtain clarification of any point in a vendor's proposal or to obtain additional information necessary to properly evaluate a proposal. Failure of a vendor to respond to such a request for additional information or clarification may result in rejection of the vendor's proposal. The HPS's retention of this right shall in no way reduce the responsibility of vendors to submit complete, accurate and clear proposals.

1.3 General RFP Procedures.

1.3.1 Right of Selection/Rejection of Proposals. HPS reserves the right to select a proposal for the project negotiations. HPS reserves the right to select or reject any or all proposals for any reason, to waive any informality in the proposals received, and to waive minor deviations from the specifications. HPS may award a contract on the basis of information in addition to that received in a proposal. It is emphasized that all quotes should be complete and submitted with the most favorable financial terms.

1.3.3 Errors in Proposals. Vendors are responsible for all errors or omissions in their proposals, and any such errors or omissions will not serve to diminish their obligations to HPS.

1.3.6 Period of Validity of Proposals. The Vendor must certify that its proposal will remain in effect for 90 days after the proposal due date. HPS may request an extension beyond the 90 days.

1.5 Proposal Format

It is essential that the Hastings Public Schools, be able to easily match a vendor's response with this RFP's requirements for information. Proposals should be submitted on 8.5 by 11 inch paper. Foldouts for charts, tables, spreadsheets, and single line diagrams are acceptable

1.7 Acceptance of Bid (Award).

1. **Owner.** HPS intends (but is not bound) to award a Contract to the lowest responsible and responsive Bidder, provided the Bid has been submitted in accordance with the requirements of the Bidding Documents and does not exceed the funds available. HPS has the right to waive any informality or irregularity in any Bid(s) received and to accept the Bid which, in Its judgment, is in Its own best interests.

1.8.1 Rejection of Bid(s): HPS shall have the right but not the obligation to reject any or all Bids for any reason or for no reason, or to reject a Bid, which is in any way incomplete or irregular.

2.3 General Implementation Requirements.

With submission of a proposal, the Vendor understands and agrees to the following:

2.3.2 This RFP is intended to represent a functional description and performance criteria for systems required. The Vendor shall conduct actual system engineering and design activities that will lead to the final system configuration.

2.3.3 The Vendor accepts any available blueprint and/or site plans provided by HPS as guideline only, and accepts that the plans are not guaranteed to be an accurate representation of all conditions.

2.3.4 The Vendor shall provide all supervision, labor, materials, and testing instrumentation required for the work associated with this RFP.

2.3.5 The Vendor shall secure all permits, inspections, and authorizations required to complete its work associated with this RFP, at no additional cost to HPS.

2.3.7 All vendors working on any HPS site shall abide by all HPS rules and State regulations. Weapons and alcohol are prohibited. All vendor employees must carry picture ID and wear identification badge at all times.

2.3.8 Vendor shall make NO penetration of walls, floors, or ceilings without the prior consent of the HPS.

2.3.9 Access hours to HPS sites will be from 8:00 a.m. to 5:00 p.m. Monday through Friday.

2.5 Customer References.

HPS specifically interested in the Vendor's experiences and responsibilities in designing and implementing systems that are comparable to the project outlined in this RFP. The Vendor must submit a minimum of two (maximum of ten) relevant references of customers where the Vendor provided a similar system (same make and/or model) within the last three years and is presently in use. The following information is required for each reference:

<u>Company Name And City</u>	<u>Contact Name and Telephone Number</u>	<u>System Size and Type</u>	<u>Date of Installation</u>
Grand Island Public Schools Grand Island	Dan Petsch 308-385-5900	Audio, Video and Lighting	2018 to Present
Third City Christian Church Grand Island	Taylor Jones (402) 419-1731	Audio, Video and Lighting	2015 to Present

There will be a **MANDATORY** walk thru at the Hastings Senior High School on this date.

May 31st, 2022 at 2:00 PM

REQUIRED attendance to be able to bid this project. If you are unable to attend this meeting you may contact HPS (Mr. Yost or Mr. Kelly) to accommodate another date. However, it will be at the sole discretion of HPS to accommodate the request.

Proposal Date: June 8th, 2022

Prepared by: R8 Productions

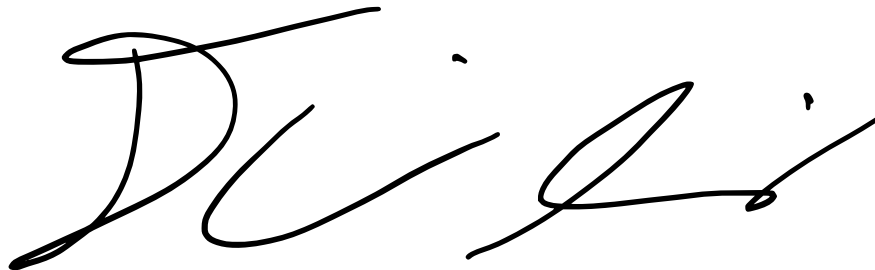
A handwritten signature in black ink, appearing to read 'Davis Goodwin', written in a cursive style.

Davis Goodwin, Owner

HPS is seeking a turnkey proposal including the following things. This list is to include labor, materials, beginning training, and servicing availability for 2 years. Upon completion of this project, the venue should be show ready with all items hung, programmed, addressed, tuned, and wired. The only existing materials that are to be used include three (3) floor pots already on stage. All other equipment is to be removed and remain the sole property of HPS. At this time, no substitutions are allowed for any of the following items.

LIGHTING			
Item	Description		QTY
Chauvet Pro Ovation E-910FC	273W RGBA+Lime LED Ellipsoidal, No Lens Tube		10
CHAUVET PROFESSIONAL Ovation Ellipsoidal HD Lens Tube	(26, Black)		10
Chauvet Pro Ovation P-56FC	175W RGBA-Lime LED PAR with Lenses		16
Blizzard Cyc Out	256x3W RGBW LED Strobe, Cyc, Blinder Fixture		6
The Light Source MNB	Mini-Clamp, Black		38
Altman SC-36-BK	36" Safety Cable, Black		32
ETC R15	Dual 15A 120V Relay Module		10
CM Lodestar CH-1/2T-F-1P-00	1/2 Ton Model F 40' Lift Single Phase Chain Hoist Motor		2
Chain Motor Relay Control System			2
Global Truss SQ-4114 BLK	9.84' (3M) Square Segment, Black		3
VRL 10' DMX	Lighting DMX Cable		40
Interactive	CueStation Universal		1

Technologies ST-HUB-EN	Hub with Ethernet		
Interactive Technologies ST-MN2-CB-RGB	Mystique 5-Wire 2-Button Network Station in Black with RGB LED Indicators		3
Extra DMX Cables	10 x ~6', 5 x 10', 5 x 25', 2 x 50', 2 x 100'		1

AUDIO

Item	Description		QTY
Q-Sys Core 110F	Audio and Visual Processing and Control System		1
Q-Sys TSC-55w-G2-BK	Touch Screen Control Panel		2
Q-SYS Core 110 UCI Deployment Software License	Perpetual	Need to purchase via vendor.	1
Q-SYS Core 110 Scripting License	Perpetual	Need to purchase via vendor.	1
D-Link 24 28 Port Fast Ethernet PoE+ Managed Switch Web Smart 2 Gigabit BASE-T and 2 Gigabit Combo BASE-T/SFP Ports	(DES-1210-28P)		1
FBT Mitus 206LA 600W + 300W – 134dB SPL Active precision coverage vertical array			10
FBT MT-F206 Fly Bar for Mitus 2016			2
FBT MUSE 218S Bass reflex Passive Subwoofer	2x18" - 4000Wrms		2
Crown XLC2500	2-Channel, 500W at		1

	4 Ohm Cinema Power Amplifier		
VENTIS 112 M 2-way Passive monitor	12" + 1" - 500Wrms		2
FBT CLA 403 TW	Passive Line Array Column - 4x3" - 120Wrms - 110°H x 25°V/50°V - IP 55 - EN54-24 - White (Delay Speakers)		4
VT-W 3 W	Standard wall mount bracket for CLA403/803		4
LEA Professional CS354D 4-Channel 350W Dante Power Amp	w/DSP, Ethernet, IoT-Enabled		1
Shure QLXD4	Single-Channel Digital Half-Rack Wireless Mic Receiver		7
Shure QLXD2/SM58	Digital Wireless Handheld Transmitter with SM58 Mic		5
Shure QLXD1	Digital Wireless Bodypack Transmitter		2
Shure DH5/O-MTQG Omnidirectional Duraplex Headset	w/ MTQG Connector		2
Shure UA864US Wall-Mounted Wideband Antenna			2
Shure UA844+SWB/LC 5-Way Active Antenna Splitter and Power Distribution System	for QLX-D, ULX, ULX-D, SLX, and BLX4R Receivers (470-952MHz)		2
Shure MX202B/C Microflex Cardioid Condenser Overhead Mic	with 4" Gooseneck, 30' XLR Cable, and In-Line Preamp, Black		8

Tascam ML-16D	16-Channel Analog, Dante Converter		1
Tascam BO-32DE	32-Channel Euroblock to D-Sub Breakout Box		1
Pro Co AODDP-4XF	Dante 4 Chan - Input Wall Plate Box		4
Radial Engineering CATapult Mini TX 4-Channel Audio Over CAT5 Cable Transmitter			2
Radial Engineering CATapult Mini RX 4-Channel Audio Over CAT5 Cable Receiver			2
Attero Tech UNA6IOBT	AES67 Networked Audio Wall Plate, 4x2 Multi I/O with Bluetooth		1
PreSonus StudioLive 64S	64-Channel Digital Mixer		1
PreSonus AVB to Dante Bridge 16 Channel Input/Output AVB to Dante Bridge			2
PreSonus SW5E 5-port AVB Switch with PoE			1
Extra XLR Cables	10 x 10', 5 x 25'		1

OTHER

Item	Description		QTY
Install	Complete installation of equipment.		1
Auxiliary Hardware	Conduit, j-boxes, cable, ect		1

Service Availability	2 years with a 48-hour response limit.		1
Training	Any training needed for staff to be able to utilize the newly installed systems		1

R8 Productions

1604 S Harrison St
Grand Island, NE 68803 US
(308) 3088506393
davis@r8productions.com



ADDRESS

Christian Yost
Hastings Senior High School
1100 W. 14th Street
Hastings, NE 68901

Estimate 1313

DATE 04/05/2022

ACTIVITY	QTY
Sales Chauvet Pro Ovation E-910FC 273W RGBA+Lime LED Ellipsoidal, No Lens Tube	10
Sales CHAUVET PROFESSIONAL Ovation Ellipsoidal HD Lens Tube (26 , Black)	10
Sales Chauvet Pro Ovation P-56FC 175W RGBA-Lime LED PAR with Lenses	16
Sales Blizzard Cyc Out 256x3W RGBW LED Strobe, Cyc, Blinder Fixture	6
Sales The Light Source MNB Mini-Clamp, Black	38
Sales Altman SC-36-BK 36" Safety Cable, Black	32
Sales ETC R15 Dual 15A 120V Relay Module	10
Sales CM Lodestar CH-1/2T-F-1P-00 1/2 Ton Model F 40' Lift Single Phase Chain Hoist Motor	2
Sales Chain Motor Relay Control System	2
Sales Global Truss SQ-4114 BLK 9.84' (3M) Square Segment, Black	3

ACTIVITY	QTY
VRL 10' DMX Lighting DMX Cable	40
Sales Interactive Technologies ST-HUB-EN CueStation Universal Hub with Ethernet	1
Sales Interactive Technologies ST-MN2-CB-RGB Mystique 5-Wire 2-Button Network Station in Black with RGB LED Indicators	3
Sales Extra DMX Cables 10 x ~6', 5 x 10', 5 x 25', 2 x 50', 2 x 100'	1
Sales Q-Sys Core 110F Audio and Visual Processing and Control System	1
Sales Q-Sys TSC-55w-G2-BK Touch Screen Control Panel	2
Sales Q-SYS Core 110 UCI Deployment Software License, Perpetual.	1
Sales Q-SYS Core 110 Scripting License, Perpetual.	1
Sales D-Link 24 28 Port Fast Ethernet PoE+ Managed Switch Web Smart 2 Gigabit BASE-T and 2 Gigabit Combo BASE-T/SFP Ports (DES-1210-28P)	1
Sales FBT Mitus 206LA 600W + 300W – 134dB SPL Active precision coverage vertical array	10
Sales FBT MT-F206 Fly Bar for Mitus 2016	2
Sales FBT MUSE 218S Bass reflex Passive Subwoofer - 2x18" - 4000Wrms	2
Sales Crown XLC2500 2-Channel, 500W at 4 Ohm Cinema Power Amplifier	1
Sales VENTIS 112 M 2-way Passive monitor - 12" + 1" - 500Wrms	2
Sales FBT CLA 403 TW Passive Line Array Column - 4x3" - 120Wrms - 110 H x 25 V/50 V - IP 55 - EN54-24 - White (Delay Speakers)	4
Sales VT-W 3 W Standard wall mount bracket for CLA403/803	4
Sales LEA Professional CS354D 4-Channel 350W Dante Power Amp w/DSP, Ethernet, IoT-Enabled	1
Sales Shure QLXD4 Single-Channel Digital Half-Rack Wireless Mic Receiver	7
Sales Shure QLXD2/SM58 Digital Wireless Handheld Transmitter with SM58 Mic	5

ACTIVITY	QTY
Sales Shure QLXD1 Digital Wireless Bodypack Transmitter	2
Sales Shure DH5/O-MTQG Omnidirectional Duraplex Headset w/ MTQG Connector	2
Sales Shure UA864US Wall-Mounted Wideband Antenna	2
Sales Shure UA844+SWB/LC 5-Way Active Antenna Splitter and Power Distribution System for QLX-D, ULX, ULX-D, SLX, and BLX4R Receivers (470-952MHz)	2
Sales Shure MX202B/C Microflex Cardioid Condenser Overhead Mic with 4" Gooseneck, 30' XLR Cable, and In-Line Preamp, Black	8
Sales Tascam ML-16D 16-Channel Analog, Dante Converter	1
Sales Tascam BO-32DE 32-Channel Euroblock to D-Sub Breakout Box	1
Sales Pro Co AODDP-4XF Dante 4 Chan - Input Wall Plate Box	4
Sales Radial Engineering CATapult Mini TX 4-Channel Audio Over CAT5 Cable Transmitter	2
Sales Radial Engineering CATapult Mini RX 4-Channel Audio Over CAT5 Cable Receiver	2
Sales Attero Tech UNA6IOBT AES67 Networked Audio Wall Plate, 4x2 Multi I/O with Bluetooth	1
Sales PreSonus StudioLive 64S 64-Channel Digital Mixer	1
Sales PreSonus AVB to Dante Bridge 16 Channel Input/Output AVB to Dante Bridge	2
Sales PreSonus SW5E 5-port AVB Switch with PoE	1
Sales Extra XLR Cables 10 x 10', 5 x 25'	1
Auxiliary Hardware Data Cabling, Conduit, J-Boxes, Rigging Supplies, etc.	1
Install Engineer Labor	1
Auditorium Lighting and Sound Upgrade	

TOTAL

\$154,884.80

Accepted By

Accepted Date

QUOTATION: 31849

Electronic Contracting Company Inc.
6501 N 70th St.
Lincoln, NE 68507

PO Box 29195
Lincoln, NE 68529



BILL TO		JOB LOCATION	
Company: HASTINGS PUBLIC SCHOOL	Company: HASTINGS SENIOR HS	Date: 2022-06-06	
Address: 1924 WEST A ADMINISTRATION BLDG HASTINGS, NE 68901	Address: 1100 W 14th ST HASTINGS, NE 68901	Sales Rep: Greg Scott	
Contact: Trent Kelly	Contact: Christian Yost	Phone: (402) 658-4040	
Phone: 402-469-2094	Phone: 402-690-9978	Email: gscott@eccoinc.com	
		Expiration Date: 2022-09-05	

TITLE
Hastings Sound & Lighting Systems

SCOPE OF WORK

This proposal recognizes the documents "1.1 Purpose and Scope" of the Hasting Public Schools RFP, and "HPS Sound Lighting Itemized List." Completion deadline of September 1st can NOT be recognized by ECC due to the current supply chain issues. Zero blueprints or site plans were provided along with the RFP and equipment list (SEE 2.3.3). All cabling and accessories are assumed to be included. All labor is included. Commission – We will provide testing, tuning, and training for all systems installed with the client. It is assumed all existing equipment (if re-used), or equipment called out in the "itemized List" is in good working order and will complete fully functioning systems. If engineering finds systems to be incomplete and require additional items for proper function, owner agrees to the billable add. Please note: There is no rental or electrical in this proposal, those needs are to be provided by owner.

Terms & Conditions

THESE BUSINESS TERMS (these Terms) are the general terms and conditions under which ECC will provide services to Client (the Services) under the Proposal to which they are attached (the Agreement). To the extent any purchase order contains any terms that are inconsistent with these Terms, those inconsistent terms are rejected by ECC.

- 1) Independent Contractors.** ECC's relationship with Client will be that of an independent contractor, and nothing in the Agreement should be construed as creating a partnership, joint venture, or employer-employee relationship. ECC will have sole discretion to determine the manner, method, and means of performing the Services.
- 2) Payment.** ECC shall receive payment for the Services as provided in the Agreement. Unless otherwise provided in the Agreement, invoices will be issued upon completion of the Services. All amounts payable under the Agreement are exclusive of sales, use, VAT, customs duties, excise, and any other applicable transaction taxes unless otherwise stated in the proposal. Except as otherwise required by the Agreement, Client shall make payment on invoices within thirty (30) days after issuance. If payment of any amount due under the Agreement is not received when due, interest shall begin to accrue and be payable at the lesser of the maximum rate permitted under applicable law or at the rate of six percent (6.0%) per month from the date due until paid in full. Client's obligation to pay all amounts due under the Agreement is absolute and unconditional, and Client is not entitled to any setoffs to such amounts.
- 3) Warranties.** ECC MAKES NO WARRANTY OF MERCHANTABILITY OR FITNESS FOR A PARTICULAR PURPOSE. THE WARRANTIES MADE IN THESE TERMS ARE EXPRESSLY IN LIEU OF ANY OTHER WARRANTIES, EXPRESSED OR IMPLIED, AND ANY OTHER OBLIGATIONS OR LIABILITIES ON THE PART OF ECC, WHICH NEITHER ASSUMES NOR AUTHORIZES ANY OTHER PERSON TO ASSUME FOR IT ANY OTHER LIABILITY IN CONNECTION WITH THE SERVICES.
- 4) Intellectual Property Rights.** Client acknowledges and agrees that ECC is the owner of, or holds license to, all right, title, and interest, including copyright and all other intellectual property rights, in and to any and all written materials, documents, flow charts, logic diagrams, source code, test materials, or other information relating to any intellectual property generated in providing the Services (collectively the "Work Product"). No transfer of ownership of any Work Product is intended by the Agreement, and Client agrees that it may not, and may not encourage any third party to, attempt to derive the source code or reverse engineer the Work Product.
- 5) Non-Solicitation.** Client acknowledges that ECC has invested in the training and development of ECC's employees and that ECC's employees are one of its most valuable assets. Accordingly, during the term of providing Services and for one (1) year thereafter, Client shall not solicit for employment any employees of ECC or its affiliates who: (a) directly performed under the Agreement, (b) had substantial contact with Client in relation to the Agreement, or (c) Client became aware of due to, or derived from information learned through the performance of, the Agreement. For this purpose, "solicitation" does not include contact resulting from indirect means such as public advertisement, placement firm searches, or similar means not directed specifically at the employee to which the employee responds on his or her own initiative.
- 6) Allocation of Risk.**
 - a) **Indemnification.** Client will indemnify and hold harmless ECC from all claims, liabilities, or expenses for damage to real property or tangible personal property, bodily injury, including death, and any other losses or damages arising out of the conduct of Client or its employees or agents.
 - b) **Limitation of Liability.** ECC'S LIABILITY FOR DAMAGES ARISING OUT OF OR RELATING TO THE AGREEMENT IS LIMITED TO THE FEES PAID BY CLIENT FOR THE SERVICES PROVIDED UNDER THE AGREEMENT FOR THE PERIOD OF ONE (1) YEAR PRIOR TO THE EVENT GIVING RISE TO LIABILITY. ECC SHALL NOT HAVE ANY LIABILITY WHATSOEVER TO CLIENT OR TO ANY THIRD PARTY FOR ANY LOSS OF PROFITS, OTHER CONSEQUENTIAL DAMAGES OR INCONVENIENCE DUE TO EARLY TERMINATION OF THE AGREEMENT, OR ANY THEFT, DAMAGE, LOSS OF DATA, OR DELAY, EVEN IF CLIENT HAS BEEN ADVISED OF THE POSSIBILITY OF SUCH DAMAGES.
 - c) **Attorney Fees.** Client agrees to reimburse ECC and any of its owners, employees, and agents for any attorney fees, costs, and expenses incurred: (a) successfully enforcing any part of the Agreement; or (b) successfully defending all or part of any state or federal court lawsuit that Client may file against ECC and/or any individual in their capacity as an owner, employee, or agent of ECC.
- 7) Termination.** The Agreement may be terminated by either party if the other party has materially breached the Agreement and has failed to cure such breach within thirty (30) days after receipt of written notice thereof. Upon termination of the Agreement as set forth above, ECC may terminate any and all licenses granted to Client under the Agreement. Furthermore, upon termination of the Agreement for any reason, Client shall pay to ECC within five (5) days of receipt of a final invoice all fees due under the Agreement.
- 8) Miscellaneous.**
 - a) **Enforceability.** The invalidity or unenforceability of any particular provision of these Terms will not affect the Agreement's other provisions, which are then to be applied as if the invalid or unenforceable provision were omitted.
 - b) **Integrated Agreement.** Except for any purchase orders issued hereunder, there are no agreements, understandings, restrictions, warranties, or representations on which Client may rely relating to providing the Services. Furthermore, no future agreements, understandings, restrictions, warranties or representations may be relied upon by Client unless they are set forth in writing by an authorized representative of ECC.
 - c) **Assignment.** Client may not assign or transfer any of its rights or obligations under the Agreement without the prior written consent of ECC. Any permitted assignee, successor, or purchaser shall expressly assume in writing the obligation to perform in accordance with the terms and conditions of the Agreement, and no assignment or transfer shall relieve ECC or Client of its previously accrued obligations under the Agreement.
- 9) Acceptance of Agreement** - This agreement includes equipment and services that are required to satisfy the project scope of Section 1.0
- 10) Scope of Work/Responsibilities.** ECC will begin work on this project upon receipt of a copy of this agreement duly signed and executed by an agent of the Customer, specifically authorized to bind the Customer to the terms and conditions of this agreement.

This Electronic Contracting Company (ECC) proposal is subject to a Force Majeure clause for a pandemic (e.g. Covid-19) as declared by the World Health Organization (WHO) and the corresponding governmental orders and/or regulations. This clause applies as it relates to ECC's inability to perform its contract obligations based on the unforeseeable events that may have a future impact on our labor force, the timely delivery of materials, and the escalation of the cost of said materials. ECC will keep you apprised if this situation develops and all parties to this proposal will be contacted. ECC does welcome the opportunity to work together to develop risk avoidance and mitigation strategies with you and all other parties involved (e.g. Owner, General Contractor, Architects, Engineers, etc.).

Payment Terms

- 35% Down to Initiate the Project
- 35% Net 30 Upon Equipment Order
- 30% Upon Substantial Completion

Note: If progressive or AIA/SOV invoicing is required, please discuss with your sales rep prior to acceptance of this proposal.

Quote does not include prevailing wage labor, client agrees if prevailing wage order is provided after execution of the contract, a change order will be issued.

Sales tax is included. If your project and/or entity is tax exempt, please provide tax exemption documents.

Subtotal:	\$257,292.55
Tax:	0.00
Total:	\$257,292.55

IF YOU WISH TO ACCEPT THIS PROPOSAL AND RELATED STATEMENT OF WORK, PLEASE SIGN AND RETURN

BUYER:

(Print Name)

BUYER SIGNATURE: _____

DATE: _____

SALES REP: Greg Scott

(Print Name)

SALES REP SIGNATURE: Greg Scott

DATE: _____

As acknowledgement that each page of the quotation was reviewed, please initial the bottom of each page.



Quote

Sales Rep. **Nathan Elstermeier**
 Email **nathan@yandasmusic.com**
 Phone **308.440.8227**
 Date **6/7/2022**

Expires: 7/7/2022

Customer **Trent Kelly**
 Organization **Hastings Public Schools**
 City **Hastings, NE**

Project **Auditorium**
 Email **trent.kelly@hpsstigers.org**
 Phone **402.469.2094**

Lighting System

Product	Qty.
Chauvet Professional - Ovation E910FC	10
Chauvet Professional - Ovation Ellipsoidal HD Lens 26	10
Chauvet Pro Ovation P-56FC	16
Blizzard Cyc Out	6
The Light Source MNB Black Mini Clamp	38
Altman SC-36-BK Safety Cable	32
ETC R15 15 Amp 120v Relay Module	10
CM Lodestar 1/2 ton chain hoist CH-1/2T-F-1P-00	2
Chain Motor Relay control system	2
Global Truss SQ-4114 BLK Black Square truss	3
VRL 10' DMX	40
Interactive Technologies Cueserver CS-900	1
Interactive Cuestation Universal Hub	1
Interactive Technologies ST-MN2-CB-RGB	3
DMX Cables (10X-6',5X-10',5X-25',2X-50',2X-100')	1
Total: \$82,042.55	

Audio System

Product	Qty.
QSC Q-SYS Core 110f	1
QSC Q-SYS -55w-G2-BK	2
QSC Q-SYS Core 110f UCI Deployment license	1
QSC Q-SYS Core 110 Scripting License	1
D-Link 24 28 Port Gigabit Network Switch	1
FBT Mitus 206LA	10
FBT MT-F206 Fly bar	2
FBT MUSE 218S Subwoofer	2
Crown XLC2500	1
Ventis 112M	2
FBT CLA 403 TW (Delays)	4
Lea Professional CS354D	1
Shure QLXD4	7
Shure QLXD2/SM58(Handheld)	5
Shure QLXD1(Bodypack)	2
Shure DH5/O-MTQG	2
Shure UA864US	2
Shure UA844+SWB/LC	2
Shure MX202B/C	8
Tascam ML-16D	1

Tascam BO-32DE	1
Pro Co AODDP-4XF	4
Radial Engineering Mini TX	2
Radial Engineering Mini RX	2
Attero Tech UNAGIOBT	1
Preonus StudioLive 64S	1
Preonus AVB to Dante Bridge	2
Preonus SW5E - 5 Port Switch	1
XLR Cables (10x-10',5x-25')	1
Installation Labor	1
Auxiliary Hardware	1
Service Contract	1
Training	1

Total: \$85,317.00

Project Total: \$167,359.55

System Includes a 2 year service contract.

Signature as Acceptance of the Proposal and Terms

Date of Acceptance

Signed acceptance must be received prior to ordering of equipment for installation



Highway 65 South, Conway, AR 72032 - orders@virco.com
2027 Harpers Way, Torrance, CA 90501 - orders@virco.com

QUOTATION #8264477
r.2

Sold To:
HASTINGS PUBLIC SCHOOLS
1924 West A Street
HASTINGS NE 68901

Ship To:
ALTERNATIVE LEARNING CENTER
1106 WEST 18TH STREET
HASTINGS NE 68901
REFERENCE: 05.24.2022 | CLASSROOM AND
SOFT SEATING

Quotation Date: 6/10/2022

We appreciate the opportunity to quote the enclosed prices for our products. Unless otherwise indicated, prices are net and do not include sales tax. Please refer to the above referenced Quotation Number when corresponding with Virco regarding this quote. We offer our quotation priced from the US COMMUNITIES 2022 CONTRACT #R-TC-18004 CLASSROOM FURNITURE Contract. You will need to be registered for US Communities and provide your TIN number prior to acceptance of your purchase order. We offer our quotation subject to the following terms and conditions:

- 1) FOB Point: FOB Destination - Tailgate Delivery
- 2) Payment Terms: Net 30 days (subject to credit approval)
- 3) Prices Are Firm: For Orders Received By 6/30/2022
- 4) For Shipment By: Please note that prices are for orders placed prior to 6/30/2022 and shippable no later than 7/30/2022. Orders requiring delivery after this date will not be processed and will require a requote.
- 5) Shipment from Virco: Virco's current lead-times have been extended. All new orders will carry a minimum lead time of 8 weeks; though many orders may ship sooner. Special handling and/or equipment requests may extend the lead time an additional 4 weeks.
- 6) Color: Standard Virco colors only unless specified otherwise
- 7) Purchase Order: We require customer approval by purchase order or signed quote to be emailed to Orders@virco.com or faxed to (800) 258-7367 or (800) 396-8232
- 8) Acknowledgement: Final acceptance and acknowledgement of orders will be as stated on the standard Virco Purchase Order Acknowledgment
- 9) Quantity: Any change in quantities may result in a price change



Highway 65 South, Conway, AR 72032 - orders@virco.com
2027 Harpers Way, Torrance, CA 90501 - orders@virco.com

QUOTATION #8264477

r.2

COVID-19 NOTICE

Thank you for the opportunity to provide a quote for your furniture and equipment needs. Due to the Covid-19 pandemic, Virco wants to ensure your order will be processed with little to no interruption. If this quote generates a purchase order from your district, please include any and all detailed delivery instructions including point of contact, direct phone number to confirm delivery, and requested delivery date. Orders that do not include specific delivery instructions will be entered and processed to ship as soon as product is available.

In the event you experience an unexpected closure of your facility due to COVID-19, and your shipments are already in transit, Virco will help redirect your shipments to a local destination of your choice.

If you are unable to receive your shipments, Virco can arrange to return your products to our warehouse and store your shipments until your facility has been approved to receive your furniture. All associated fees will be passed along to the customer for transportation cost, storage & handling fees as well as redelivery fees.



QUOTATION #8264477
r.2

Shipping To: ALTERNATIVE LEARNING CENTER

Tag #	Supplier/Model #	Description	Unit Price	Qty	Extension
1	Virco Inc #ZADJ2026M	Desk, Zuma Series, Student Desk, 4-Leg, Adjustable 22"-34" H, 20 X 26-1/8" Hard Plastic Top, Nylon-Base Glides (Color Not Selected)	\$166.68	22	\$3,666.96
2	Virco Inc #Z2026SUM	Desk, Zuma Series, Standing Height Desk, 4-leg, Adjustable 29"-41"H, 20 X 26-1/8" Hard Plastic Top (Color Not Selected)	\$178.48	10	\$1,784.80
3	Virco Inc #AN18EL	Chair, Analogy(tm) Series, 4-Leg, Stackable, 18-1/2" Seat Height, Ergonomically Contoured Extra Large Polypropylene Shell, Steel Frame, Nylon-Base Swivel Glides With Color-Accented Glide Sleeve (Color Not Selected)	\$84.37	30	\$2,531.10
4	Virco Inc #CA30EL	Stool, Civitas® Series, 4-Leg, 30" Seat Height, Ergonomically Contoured Extra Large Analogy® Polypropylene Shell, Steel Frame, Nylon-Base Swivel Glides. (Color Not Selected)	\$94.11	10	\$941.10
5	High Point #5827UAGrade4	Club Teaming Chair Withy Upholstered Arms - Tablet Arm - Brushed Aluminum Cylinder Legs - Front Glides - Rear Casters (Color Not Selected)	\$1,472.56	12	\$17,670.72
6	Virco Inc #ANTASK18	Chair, Analogy(tm) Series, Mobile Task Chair, Ergonomically Contoured Polypropylene Shell, Adjustable Gas Cylinder For 16" To 20-1½" Seat Height, Chair Swivels 360°, Five Dual-Wheeled Caster Base With 2" Hooded Swivel Caste (Color Not Selected)	\$202.08	1	\$202.08
Total					\$26,796.76



QUOTATION #8264477
r.2

Shipping To: ALTERNATIVE LEARNING CENTER

Tag #	Supplier/Model #	Description	Unit Price	Qty	Extension
-------	------------------	-------------	------------	-----	-----------

The undersigned certifies understanding and agreement of this Quote Letter and has authority to sign for purchase.

HASTINGS PUBLIC SCHOOLS
1924 West A Street
HASTINGS NE 68901

X _____
PO # (if available)

X _____
Name (Print)

X _____
Authorized Signature

If paying by credit card, please call 877-311-9157. The credit specialist will be pleased to assist with your payment.

How To Place Your Order With Virco

3 Ways To Order:

1. Email your PDF quote from Virco to orders@virco.com (please make sure the quote is signed before submitting)
2. Email your standard PO to orders@virco.com
3. Order online at Shop.Virco.com (must register with Inside Sales)

What to Expect Once Order Is Placed *(see below to complete the order process)*

- We will respond to let you know your order was received.
- Once we process your order, an electronic or paper acknowledgment will be sent

In Order to Complete the Order Process, Virco Must Receive The Following Information

Account Info

- "Sold To" Information
- "Ship To" Information
- Pricing source

Delivery Info

- Delivery contact information (name and phone number for a call before delivery)
- Special delivery requests such as specific delivery hours
- Requested delivery date if applicable (orders without requested delivery dates will be entered under ASAP priority and will be shipped as soon as product is ready)

****Please note - our system only allows 8 lines of 30 characters each so please make sure to prioritize any delivery info****

Product Info

- Model (Ex: 9018, ZBOOMMFG)

Color/Finish for the Following:

CHAIRS

- Bucket Color Frame Color Glide
(Ex: Navy/Chrome/Nylon Glides)

TABLES/DESKS

- Top/Edge Banding Frame Color Glide
(Ex: Dry Creek Plum/Adobe/Silver Mist/Felt Glides)





FILING CABINETS

- Frame Color
(Ex: Moonstone)



QUOTE #8264477

r.2

Tag	Supplier/Model #	Description	
1	Virco Inc #ZADJ2026M	Desk, Zuma Series, Student Desk, 4-Leg, Adjustable 22"-34" H, 20 X 26-1/8" Hard Plastic Top, Nylon-Base Glides 22 ea (Color Not Selected)	 <p align="center">Image Does Not Reflect Actual Color Priced</p>
2	Virco Inc #Z2026SUM	Desk, Zuma Series, Standing Height Desk, 4-leg, Adjustable 29"-41"H, 20 X 26-1/8" Hard Plastic Top 10 ea (Color Not Selected)	 <p align="center">Image Does Not Reflect Actual Color Priced</p>
3	Virco Inc #AN18EL	Chair, Analogy(tm) Series, 4-Leg, Stackable, 18-1/2" Seat Height, Ergonomically Contoured Extra Large Polypropylene Shell, Steel Frame, Nylon-Base Swivel Glides With Color-Accented Glide Sleeve 30 ea (Color Not Selected)	 <p align="center">Image Does Not Reflect Actual Color Priced</p>
4	Virco Inc #CA30EL	Stool, Civitas® Series, 4-Leg, 30" Seat Height, Ergonomically Contoured Extra Large Analogy® Polypropylene Shell, Steel Frame, Nylon-Base Swivel Glides. 10 ea (Color Not Selected)	 <p align="center">Image Does Not Reflect Actual Color Priced</p>

QUOTE #8264477

r.2

Tag	Supplier/Model #	Description	
5	High Point #5827UAGrade4	Club Teaming Chair Withy Upholstered Arms - Tablet Arm - Brushed Aluminum Cylinder Legs - Front Glides - Rear Casters 12 ea (Color Not Selected)	 <p align="center">Image Does Not Reflect Actual Color Priced</p>
6	Virco Inc #ANTASK18	Chair, Analogy(tm) Series, Mobile Task Chair, Ergonomically Contoured Polypropylene Shell, Adjustable Gas Cylinder For 16" To 20-1½2" Seat Height, Chair Swivels 360°, Five Dual- Wheeled Caster Base With 2" Hooded Swivel Caste 1 ea (Color Not Selected)	 <p align="center">Image Does Not Reflect Actual Color Priced</p>

TEACHING FELLOWSHIP AGREEMENT

This Agreement is made the _____ day of July, 2022, between the Nebraska State Education Association (NSEA), the Hastings Education Association (HEA), and School District No. 01-0018 of Adams County, Nebraska, a/k/a Hastings Public Schools (District), and Ben Welsch (Welsch).

In consideration of the mutual promises set forth herein, the parties agree as follows:

1. Scope of Project. Welsch is a teacher employed by the District. The District shall grant Welsch a one-year leave of absence to serve under a one-year Teaching Fellowship for the NSEA. Welsch shall remain an employee of District with full pay and benefits during the term of his leave. The NSEA shall reimburse the District in an amount equal to the cost of Welsch's salary and benefits for the term of his leave. Welsch will report directly to NSEA Field and Special Projects Manager, Michelle Raphael, as a Teaching Fellow for the NSEA.

2. NSEA's Obligations.

- a. NSEA will pay District Welsch's salary and benefits for the 2022-2023 contract year in an approximate amount of \$112,018.38, to reimburse District for the full cost of Welsch's salary and benefits for the term of his leave. District will invoice the NSEA quarterly for Welsch's salary and benefits which shall be paid by the NSEA within fourteen (14) days of receipt. District shall issue its first invoice on or about _____, 2022.
- b. NSEA will pay Welsch reasonable out-of-pocket expenses incurred on behalf of the NSEA provided said expenses were preapproved in writing.

3. District's Obligations.

- a. The District shall place Welsch on a paid leave of absence for the 2022-2023 contract year, and District will continue Welsch's employment while on leave during the term of this Agreement. Nothing in this Agreement shall preclude suspension or dismissal for just cause in accordance with District policies, regulations, and Nebraska law. During the term of his leave, District shall continue to provide Welsch with salary and benefits in the same manner and extent as would be provided Welsch as an active certificated employee of District.
- b. Upon conclusion of the Teaching Fellowship, District will assign Welsch to a position comparable to that held prior to his leave and shall be granted one year of service for purposes of vertical advancement on the salary schedule for the term of his leave.

4. Welsch's Obligations.

- a. Recognizing that under this Agreement Welsch's day-to-day responsibilities will involve work performed for NSEA, Welsch will abide, to the extent relevant, to District policies and regulations during the term of this Agreement.
- b. Welsch will coordinate his schedule and time off with NSEA per NSEA policy and procedures.
- c. Welsch will maintain his current licensure and certificated status with the Nebraska Department of Education during the term of this Agreement, including satisfaction of any necessary professional development or other regulatory requirements.
- d. Welsch acknowledges that nothing in this Agreement entitles him to any benefits or compensation beyond that which he would be entitled had he continued as an active certificated employee with District during the term of this Agreement.
- e. Welsch agrees to serve as NSEA's Teaching Fellow during the term of this Agreement and perform services associated with the position and as provided by the 2022-2023 NEA/NSEA Teaching Fellow Expectations.

5. HEA's Consent. HEA agrees and consents to Welsch's participation in the Teaching Fellowship with the NSEA under the terms and conditions set forth herein.

6. Intellectual Property Rights. The parties expressly intend that all intellectual property rights in and to all work performed and documents produced, conceived, or authored by Welsch, either solely or jointly with others, in the course of performance of his duties as a Teaching Fellow, will be owned exclusively by the NSEA and NEA. District and Welsch assign to the NSEA all rights, title, and interest to and in all such work performed and documents produced and agree to cooperate with the NSEA in executing any documents that confer or aid in conferring such rights, title, and interest to NSEA and NEA.

7. Confidential Information. The parties will keep in strictest confidence all information which may be acquired in connection with or as a result of performance of this Agreement or Welsch's position as Teaching Fellow, except to the extent that such information is or becomes generally available to the public or to the extent required by law. Welsch agrees to comply with NSEA policies, procedures, and practices regarding treatment of confidential information. Upon termination of this Agreement, the receiving party will deliver to the disclosing party all papers, documents, records, data, information, and other materials acquired in connection with or as a result of performance of this Agreement, and such will remain the property of disclosing party.

8. Term. Welsch's assignment as a Teaching Fellow at NSEA shall run concurrently with Welsch's teaching contract with District for the 2022-2023 contract year unless terminated in accordance with this Agreement.

9. Termination. NSEA or District may terminate this Agreement with forty-five (45) days of written notice to all parties. In the event of termination, payments between NSEA and District shall be prorated to the date of termination.

10. Nondiscrimination. In accordance with the Nebraska Fair Employment Practice Act and Neb. Rev. Stat. § 48-1122, NSEA, HEA, and District agree that they will not discriminate in their respective employment practices, and will render services under this Agreement without regard to race, color, national origin, religion, sex (including pregnancy), marital status, sexual orientation, disability, age, genetic information, gender identity, gender expression, citizenship status, veteran status, political affiliation, or economic status. Any act of discrimination or failure to comply with these statutory obligations when applicable shall be grounds for termination of this Agreement.

11. Work Eligibility. Pursuant to Neb. Rev. Stat. §§ 4-108 through 114, the parties shall use a federal electronic verification program authorized by the Illegal Immigration Reform and Immigration Responsibility Act of 1996, 8 U.S.C. § 1324 (“E-verify Program” or an equivalent federal program designated by the Department of Homeland Security or other authorized federal agency) to verify the work eligibility status of new employees physically performing services within the State of Nebraska.

12. Public Benefits. Neither NSEA, HEA, nor District is an individual or sole proprietorship. Therefore, neither NSEA, HEA, nor District is subject to the public benefits attestation and related requirements of Neb. Rev. Stat. §§ 4-108 et seq. For purposes of complying with Neb. Rev. Stat. §§ 4-108 et seq., Welsch attests that he is a citizen of the United States. Welsch hereby attests that his response and the information provided in this paragraph and any related application for public benefits are true, complete, and accurate and Welsch understands that this information may be used to verify his lawful presence in the United States.

13. Data Privacy and Protection. NSEA acknowledges that in performance of this Agreement, District may provide NSEA with personal information relating to Welsch, which is defined in and protected under Neb. Rev. Stat. §§ 87-801 to 87-808. NSEA warrants, in accordance with Neb. Rev. Stat. § 87-808, that NSEA has implemented and will maintain, throughout the term of this Agreement, reasonable security procedures and practices that: (i) are appropriate to the nature of the personal information disclosed to NSEA; and (ii) are reasonably designed to help protect the personal information from unauthorized access, acquisition, destruction, use, modification, or disclosure.

14. Miscellaneous.

- a. No party to this Agreement may assign its obligation, this Agreement, or both without the prior written consent of all parties. Any assignment in violation of this subparagraph will be void.
- b. District shall not be liable for any act or omission on the part of Welsch during the term of this Agreement and shall incur no liability for loss, damage, or injury of whatever nature sustained by Welsch during the Agreement except that District

will continue to serve as Welsch’s employer under Workers’ Compensation laws. NSEA hereby indemnifies District against any and all claims, liabilities, actions, proceedings, costs, losses, damages, and demands, arising out of or resulting from: its breach of this Agreement; any act or omission of default incurred, arising out of or in connection with the provisions of service by NSEA pursuant to this Agreement; any act, omission, or default of NSEA, or any other person for whose actions NSEA is liable, at any time before, during, or after Welsch’s assignment as a Teaching Fellow; Welsch’s assignment as a Teaching Fellow; or any workplace injury sustained by Welsch while serving as a Teaching Fellow.

- c. If any provision of this Agreement is held invalid or unenforceable by a court of competent jurisdiction, such provision will be deemed deleted from this Agreement and replaced by a valid and enforceable provision which so far as possible achieves the parties’ intent in agreeing to the original provision. The remaining provisions of this Agreement will continue in full force and effort.
- d. The provisions of this Agreement may not be modified, amended, or waived, except by a written instrument duly executed by all parties.
- e. Any notice required to be given under this Agreement will be deemed to have been sufficiently given either when served personally, United States Mail, postage prepaid, or email and will be deemed given when sent:

Trish Guinan
Executive Director
Nebraska State Education Association
605 South 14th Street
Lincoln NE 68508
trish.guinan@nsea.org

Superintendent of Schools
Hastings Public Schools
1924 West A Street
Hastings NE 68901
[Email]

President
Hastings Education Association
1924 West A Street
Hastings NE 68901
[Email]

Ben Welsch
1120 N Colorado Avenue
Hastings, NE 68901
benwelsch5@gmail.com

- f. This Agreement will be construed under, and governed by, the laws of Nebraska.
- g. This Agreement supersedes all prior oral or written agreements, if any among the parties relating to any and all matters dealt with herein, and constitutes the entire agreement among the parties as to said matters.

IN WITNESS WHEREOF, the parties have executed this Agreement as of the day and year first written above.

NEBRASKA STATE EDUCATION ASSOCIATION

By: _____
Trish Guinan, Executive Director

Date

HASTINGS EDUCATION ASSOCIATION

By: _____
President

Date

BEN WELSCH

By: _____
Ben Welsch

Date

SCHOOL DISTRICT NO. 01-0018 OF ADAMS COUNTY,
NEBRASKA, A/K/A HASTINGS PUBLIC SCHOOLS

By: _____
President, Board of Education

Date

Attest: _____
Secretary, Board of Education

Date



Restaurant Design Equipment & Supply





Formerly Institutions Services, Inc.

Project:
Lunchtime-Hastings Public Schools
Equipment



From:
IS Restaurant Design Equipment &
Supply
Amanda Poe
1421 B. Avenue
Sioux Falls, SD 57104
605-339-3931
amandap@isdakota.com



Job Reference Number: 21750

Item	Qty	Description	Sell	Sell Total
1	1 ea	REACH-IN FREEZER  Turbo Air Model No. TSF-72SD-N Super Deluxe Freezer, reach-in, three-section, 63.8 cu. ft., self-contained, stainless steel front & side, galvanized back & top of the cabinet, stainless steel interior, (3) hinged solid doors with recessed handles, (9) adjustable stainless steel wire shelves, exterior LED digital thermometer, door-open alarm beeps, self-diagnostic monitoring system, smart defrost, automatic fan motor delays, door pressure release device, LED interior lighting, self-cleaning condenser equipped, door locks, bottom mount compressor, R290 Hydrocarbon refrigerant, 3/4 HP, 115v/60/1-ph, 6.5 amps, NEMA 5-20P, cETLus, ETL-Sanitation, ENERGY STAR®	\$9,662.03	\$9,662.03
	1 ea	Note: Contact factory representative for parts & accessories discounts		
	1 ea	3 year parts & labor warranty, standard (self-contained only)		
	1 ea	7 year compressor warranty (self-contained only), (updated warranty & spec sheets pending from Turbo Air)		
	1 ea	Self-cleaning condenser device equipped, standard		
	1 ea	TSP-2250 Full Size Pan Rack, 21"W x 24"D x 50"H, fits in full door for refrigerators & freezers, 304 stainless steel construction, resists corrosion in high moisture refrigerated environments, (15) full size pan (18"x26") capacity, KD	\$708.04	\$708.04
	1 st	Caster Set, swivel, locking front wheels, standard		
	1 ea	Special location delivery, i.e. government site, institute, trade show, church, school, army base, etc., over 500lbs (net)	\$105.00	\$105.00
			ITEM TOTAL:	\$10,475.07
2	6 ea	MICROWAVE STEAMER OVEN	\$4,195.80	\$25,174.80

Item	Qty	Description	Sell	Sell Total
		Panasonic Model No. NE-3280 PRO2 Sonic Steamer Microwave Oven, ventless, 3200 Watts, 1.6 cu. ft. capacity, connectionless, rethermalizer, (5) power levels, (4) heating elements, 3-stage cooking, 16 program memory capacity, digital display, dial timer, removable center shelf, see-thru drop down door, stainless steel cabinet & cavity, cULus, NSF		
	6 ea	3 year parts & labor warranty and 3 year magnetron warranty		
	6 ea	208v/60/1-ph, 28.0 amps, NEMA 6-30P, standard		
	6 ea	Freight FREIGHT Freight	\$157.50	\$945.00
			ITEM TOTAL:	\$26,119.80
3	1 ea	RANGE, 24", 4 OPEN BURNERS	\$1,710.77	\$1,710.77
		Turbo Air Model No. TAR-4 Radiance Restaurant Range, gas, 24", (4) 32,000 BTU/hr each lift-off top open burners, (1) standard oven with (1) rack, stainless steel front, sides & back riser lift-off high shelf, full stainless steel oven interior, adjustable oven thermostat, 26.3" D standard, 6" stainless steel adjustable legs standard, regulator included, total 163,000 BTU, CSA, CSA-Sanitation		
	1 ea	Note: Contact factory representative for parts & accessories discounts		
	1 ea	1 year labor & parts warranty, standard		
	1 ea	Gas type to be specified		
	1 ea	Special location delivery, i.e. government site, institute, trade show, church, school, army base, etc., less than 500lbs (net)	\$73.50	\$73.50
			ITEM TOTAL:	\$1,784.27
4	1 ea	CONVECTION OVEN, GAS	\$4,019.59	\$4,019.59
		Moffat Model No. G32D5 Turbofan® Convection Oven, gas, full-size, single-deck, 30" assembled height, digital controls, temperature range 140 - 500° F, 1-hour cook cycle timer & 3-hour hold timer, 3-1/3" tray spacing, water injection, (5) full-size sheet pan capacity, stainless steel exterior, with glass door, porcelain interior, 33,000 BTU, ENERGY STAR®, cETLus, CSA, NSF		
	1 ea	1 year parts and labor warranty		
	1 ea	Natural gas		
	1 ea	110-120v/60/1ph, 1.0 amps, NEMA 5-15P (oven bottom deck)		
	1 ea	Door hinging on left side, standard (No Discounts Applied)		
	1 ea	3% freight surcharge	\$120.59	\$120.59
			ITEM TOTAL:	\$4,140.18
5	1 ea	HANDWASHING SYSTEM	\$1,470.74	\$1,470.74
		Crown Verity Model No. CV-EHS-E Economy Hand Sink, warm water, 1 compartment, 17 gallon fresh water capacity & 19 gallon waste water capacity, soap & paper towel dispensers, built-in handle, hands-free foot pump operation, drain hose, roll & go wheels, polyethylene construction, 120v/60		

Item	Qty	Description	Sell	Sell Total
	1 ea	1 Year warranty standard		
	1 ea	Freight FREIGHT Freight	\$157.50	\$157.50
			ITEM TOTAL:	\$1,628.24
6	1 ea	HEATED HOLDING PROOFING CABINET, MOBILE	\$3,481.54	\$3,481.54
		Metro Model No. C539-CLDC-U C5™ 3 Series Heated Holding & Proofing Cabinet, lower wattage, with Red Insulation Armour™, mobile, full height, insulated, Dutch clear polycarbonate doors, removable bottom mount control module, thermostat to 200°F, universal wire slides on 3" centers, adjustable on 1-1/2" increments (18) 18" x 26" or (34) 12" x 20" x 2-1/2" pan capacity, 5" casters (2 with brakes), aluminum, 120v/60/1-ph, 1440 watts, 12 amps, NEMA 5-15P, cULus, NSF		
	1 ea	1 year warranty against manufacturing defects		
	1 ea	Freight FREIGHT Freight	\$262.50	\$262.50
			ITEM TOTAL:	\$3,744.04
7	1 ea	WORK TABLE, STAINLESS STEEL TOP	\$562.80	\$562.80
		Advance Tabco Model No. ELAG-304C-X Special Value Work Table, 48"W x 30"D, 16 gauge 430 stainless steel top, 18 gauge galvanized adjustable undershelf, galvanized legs with casters, NSF		
	1 ea	Freight FREIGHT Freight	\$157.50	\$157.50
			ITEM TOTAL:	\$720.30
8	2 ea	WORK TABLE, STAINLESS STEEL TOP	\$354.90	\$709.80
		Advance Tabco Model No. ELAG-303-X Special Value Work Table, 36"W x 30"D, 16 gauge 430 stainless steel top, 18 gauge galvanized adjustable undershelf, galvanized legs with adjustable plastic bullet feet, NSF		
	2 ea	Freight FREIGHT Freight	\$157.50	\$315.00
	2 st	TA-25G-4-X Special Value Casters, 5" diameter, set of 4 (2 with brakes) with galvanized legs for standard working height of 35-1/2"	\$186.90	\$373.80
			ITEM TOTAL:	\$1,398.60
9	1 ea	REACH-IN REFRIGERATOR	\$5,819.24	\$5,819.24
		Beverage Air Model No. HBR49HC-1 Horizon Series Refrigerator, reach-in, two-section, 46.15 cu. ft. capacity, electronic control, (2) solid hinged self-closing doors (lockable), (6) epoxy coated wire shelves, LED lighting, adaptive defrost, bottom mounted self-contained refrigeration, stainless steel interior & exterior, R290 Hydrocarbon refrigerant, 1/3 HP, cULus, UL EPH Classified, UL-Sanitation, Made in USA		
	1 ea	3 years parts & labor warranty (excludes maintenance items)		
	1 ea	Self-Contained refrigeration		

Item	Qty	Description	Sell	Sell Total
	1 ea	Additional 4 years compressor warranty (part only), standard		
	1 ea	115v/60/1-ph, 5.0 amps, cord with NEMA 5-15P		
	1 ea	Left door hinged left, right door hinged on right, standard		
	1 ea	6" Heavy duty casters (2) locking, standard		
	1 ea	Freight FREIGHT Freight	\$525.00	\$525.00
			ITEM TOTAL:	\$6,344.24
9	1 ea	REACH-IN REFRIGERATOR	\$5,459.86	<Optional>
		Turbo Air Model No. TSR-49SD-N6 Super Deluxe Refrigerator, reach-in, two-section, 42.69 cu. ft., self-contained, stainless steel front & side, galvanized back & top of the cabinet, stainless steel interior, (2) hinged solid doors with recessed handles, LED interior lighting, (6) adjustable stainless steel wire shelves, exterior LED digital thermometer, door-open alarm beeps, self-diagnostic monitoring system, Turbo cooling, automatic fan motor delays, door pressure release device, self-cleaning condenser equipped, door locks, bottom mount compressor, R600a Hydrocarbon refrigerant, 1/5 HP, 115v/60/1-ph, 2.3 amps, NEMA 5-15P, cETLus, ETL-Sanitation, ENERGY STAR®		
				
	1 ea	Note: Contact factory representative for parts & accessories discounts		<Optional>
	1 ea	3 year parts & labor warranty, standard (self-contained only)		<Optional>
	1 ea	Additional 4 year compressor warranty (7 year total), standard		<Optional>
	1 ea	Self-cleaning condenser device equipped, standard		<Optional>
	1 st	Caster Set, swivel, locking front wheels, standard		<Optional>
			ITEM TOTAL: <Optional>	\$5,459.86
10	2 ea	TRAY RACK DISPENSER	\$2,433.40	\$4,866.80
		Piper Products/Servolift Eastern Model No. PT/915MO2 Mobile Tray Dispenser, solid bottom, double stack, self-leveling, holds (300) 10-3/4" x 15-1/4" trays, with corner bumpers, stainless steel all tubular frame, NSF		
				
	2 ea	1 year warranty parts and labor from date of purchase		
	2 st	-Y4 Polyurethane 4" casters, set of 4, with ball bearing seals	\$104.74	\$209.48
	1 ea	Freight FREIGHT Freight	\$393.75	\$393.75
			ITEM TOTAL:	\$5,470.03
11	2 ea	COMMERCIAL WASTE CONTAINER	\$41.38	\$82.76
		Rubbermaid Commercial Products Model No. FG263200GRAY Packed 6 ea ProSave® BRUTE® Container, without lid, 32 gallon, 22"D x 27-1/4"H, round, reinforced rims, built in handles, double rimmed base, high-impact plastic construction, gray, NSF, Made in USA		
				
	2 ea	FG263100GRAY BRUTE® Container Lid, 22-1/4"D x 1-3/8"H, for 32 gallon trash can, heavy duty plastic, gray, NSF, Made in USA	\$13.45	\$26.90
	2 ea	FG264000BLA Brute® Dolly, 18-1/4"D x 6-5/8"H, heavy duty 3" casters,	\$59.05	\$118.10

Item	Qty	Description	Sell	Sell Total
		250 lb. capacity, for 2620, 2632, 2643, 2655, black, NSF, Made in USA (CANNOT BREAK CASE)		
	1 ea	Freight FREIGHT Freight	\$78.75	\$78.75
			ITEM TOTAL:	\$306.51
11	1 ea	COMMERCIAL WASTE CONTAINER	\$22.54	<Alternate>
		 Carlisle Model No. 34103223 Packed 4 ea Bronco™ Waste Container, 32 gallon, 27-3/4"H x 22-3/8" dia. (25-1/2" dia. with handles), round, double-reinforced stress ribs, ergonomic Comfort Curve™ handles, drag skids, deep hand holds on base, polyethylene, gray, NSF, Made in USA		
	1 ea	3691003 Bronco™ Container Dolly, round, 6"H x 17-3/4" dia., twist-to-lock, non-marking 3" swivel threaded replaceable casters, fits 20, 32, 44 & 55 gal containers, polyethylene, black, NSF	\$42.48	<Alternate>
	1 ea	34103323 Bronco™ Waste Container Lid, round, 2-1/8"H x 22.5" dia. (25-1/2" dia. with handles), heavy-duty, snap down tab locks, for 32 gallon container, polyethylene, gray, NSF, Made in USA	\$7.12	<Alternate>
			ITEM TOTAL: <Alternate>	\$72.14
11	2 ea	CART, BUSSING UTILITY TRANSPORT, METAL WIRE	\$387.79	\$775.58
		 Metro Model No. MW403 MW Standard Duty Utility Cart, MW400 series, open design (3) shelves, (2) wire (1) solid, shelf size 36"W x 18"D, chrome plated steel frame with (2) push handles, with (4) swivel/ resilient tread casters, NSF		
	1 ea	Freight FREIGHT Freight	\$78.75	\$78.75
			ITEM TOTAL:	\$854.33
12	120 dz	COMPARTMENT TRAY	\$59.06	\$7,087.20
		 G.E.T. Enterprises Model No. TR-152-RO Packed 1 dz School & Cafeteria Tray, 14-3/8" x 9-7/8", 6 compartments, right-handed, ABS, rio orange		
	120 dz	NOTE: 8% surcharge included per each line item		
			ITEM TOTAL:	\$7,087.20
13	6 ea	CAN OPENER	\$100.09	\$600.54
		 Edlund Model No. 2 Packed 6 ea Can Opener, manual, #2™ table style with plated steel base (for standard # 10 cans up to 7" tall), "Old Reliable"™		
	6 ea	1 year limited warranty, standard		
			ITEM TOTAL:	\$600.54
14	2 ea	BUSSING UTILITY TRANSPORT CART	\$212.11	\$424.22

Item	Qty	Description	Sell	Sell Total
		Rubbermaid Commercial Products Model No. FG450088BLA Utility Cart, 39"L x 17-7/8"W x 33-1/4"H, 500 lb. capacity, (2) shelves, open base, polyethylene exterior, (2) fixed and (2) swivel 5" thermoplastic (TPR) casters, assembly required, black, Made in USA		
1 ea		Freight FREIGHT Freight	\$78.75	\$78.75
			ITEM TOTAL:	\$502.97

Subtotal	\$71,176.32
Total	\$71,176.32

Freight and sales tax are not included above and will be added to the invoice.

Price Protection: The above pricing will remain firm for a period of no more than 30 days from date of quote.

Warranty: Quoted equipment carries only the individual manufacturer's standard warranty unless specifically stated otherwise.

Note: Only the equipment and accessories shown on this quotation may be purchased at the price quoted. Items are limited to the price and quantity shown.

Note: Equipment not shown on this quotation will not be included.

Note: Please compare this quotation to your required on site utility requirements and building access.

Note: Unless otherwise indicated, this quotation covers equipment of standard design and does not include plumbing, electrical, ventilation or other accessories.

A) Prices on all products are F.O.B. origin. Freight cost is not included and will be added unless listed otherwise.

B) Receiving, Freight Inspection, Uncrating, Set Up and Installation are not included.

Acceptance: _____ Date: _____

Printed Name: _____

Project Grand Total: \$71,176.32



Sales Order

06/23/2022

To:
Hastings Public Schools
Betty Moyle
Hastings, NE 68901

Project:
Hastings Public Schools (Large
Equipment)
Maintenance Warehouse
1142 W 18th Street
Hastings, NE 68901

From:
Midwest Restaurant Supply
Bob Earll
2705 W. Hwy. 30
Grand Island, NE 68803
(308)384-5780



Job Reference Number: 7846





Item	Qty	Description	Sell	Sell Total
1	1 ea	REACH-IN FREEZER Turbo Air Model No. TSF-72SD-N Super Deluxe Freezer, reach-in, three-section, 63.8 cu. ft., self-contained, stainless steel front & side, galvanized back & top of the cabinet, stainless steel interior, (3) hinged solid doors with recessed handles, (9) adjustable stainless steel wire shelves, exterior LED digital thermometer, door-open alarm beeps, self-diagnostic monitoring system, smart defrost, automatic fan motor delays, door pressure release device, LED interior lighting, self-cleaning condenser equipped, door locks, bottom mount compressor, R290 Hydrocarbon refrigerant, 3/4 HP, 115v/60/1-ph, 6.5 amps, NEMA 5-20P, cETLus, ETL-Sanitation, ENERGY STAR®	9,789.00	9,789.00
	1 ea	Note: Contact factory representative for parts & accessories discounts		
	1 ea	3 year parts & labor warranty, standard (self-contained only)		
	1 ea	7 year compressor warranty (self-contained only), (updated warranty & spec sheets pending from Turbo Air)		
	1 ea	Self-cleaning condenser device equipped, standard		
	1 ea	TSP-2250 Full Size Pan Rack, 21"W x 24"D x 50"H, fits in full door for refrigerators & freezers, 304 stainless steel construction, resists corrosion in high moisture refrigerated environments, (15) full size pan (18"x26") capacity, KD	750.00	750.00
	1 st	Caster Set, swivel, locking front wheels, standard		
			ITEM TOTAL:	10,539.00



2	6 ea	MICROWAVE STEAMER OVEN Panasonic Model No. NE-3280 PRO2 Sonic Steamer Microwave Oven, ventless, 3200 Watts, 1.6 cu. ft. capacity, connectionless, rethermalizer, (5) power levels, (4) heating elements, 3-stage cooking, 16 program memory capacity, digital display, dial timer, removable center shelf, see-thru drop down door, stainless steel cabinet & cavity, cULus, NSF	4,260.00	25,560.00
---	------	---	----------	-----------



Item	Qty	Description	Sell	Sell Total
	6 ea	3 year parts & labor warranty and 3 year magnetron warranty		
	6 ea	208v/60/1-ph, 28.0 amps, NEMA 6-30P, standard		
			Freight: 37.50	225.00
			ITEM TOTAL:	25,785.00
3	1 ea	RANGE, 24", 4 OPEN BURNERS	1,750.00	1,750.00
		Turbo Air Model No. TAR-4		
		Radiance Restaurant Range, gas, 24", (4) 32,000 BTU/hr each lift-off top open burners, (1) standard oven with (1) rack, stainless steel front, sides & back riser lift-off high shelf, full stainless steel oven interior, adjustable oven thermostat, 26.3" D standard, 6" stainless steel adjustable legs standard, regulator included, total 163,000 BTU, CSA, CSA-Sanitation		
	1 ea	Note: Contact factory representative for parts & accessories discounts		
	1 ea	1 year labor & parts warranty, standard		
	1 ea	Gas type to be specified		
			ITEM TOTAL:	1,750.00
4	1 ea	CONVECTION OVEN, GAS	4,295.00	4,295.00
		Moffat Model No. G32D5		
		Turbofan® Convection Oven, gas, full-size, single-deck, 30" assembled height, digital controls, temperature range 140 - 500° F, 1-hour cook cycle timer & 3-hour hold timer, 3-1/3" tray spacing, water injection, (5) full-size sheet pan capacity, stainless steel exterior, with glass door, porcelain interior, 33,000 BTU, ENERGY STAR®, cETLus, CSA, NSF		
	1 ea	1 year parts and labor warranty		
	1 ea	K-12 Extended Warranty, 2 years parts & labor, additional 3 years parts only		
	1 ea	Natural gas		
	1 ea	110-120v/60/1ph, 1.0 amps, NEMA 5-15P (oven bottom deck)		
	1 ea	Door hinging on left side, standard (No Discounts Applied)		
	1 ea	3% freight surcharge	0.00	
			Freight: 275.00	275.00
			ITEM TOTAL:	4,570.00
4.1		PRICE INCREASE ON 7/01/22		
		price increase on this 7/01/22 will need to be requoted if not ordered before that date		
5	1 ea	HANDWASHING SYSTEM	2,390.00	2,390.00
		Crown Verity Model No. CV-EHS-E		
		Economy Hand Sink, warm water, 1 compartment, 17 gallon fresh water capacity & 19 gallon waste water capacity, soap & paper towel dispensers, built-in handle, hands-free foot pump operation, drain hose, roll & go wheels, polyethylene construction, 120v/60		
	1 ea	1 Year warranty standard		

Item	Qty	Description	Sell	Sell Total
			Freight: 440.00	440.00
			ITEM TOTAL:	2,830.00
6	1 ea	HEATED HOLDING PROOFING CABINET, MOBILE	3,799.00	3,799.00
		 Metro Model No. C539-CLDC-U C5™ 3 Series Heated Holding & Proofing Cabinet, lower wattage, with Red Insulation Armour™, mobile, full height, insulated, Dutch clear polycarbonate doors, removable bottom mount control module, thermostat to 200°F, universal wire slides on 3" centers, adjustable on 1-1/2" increments (18) 18" x 26" or (34) 12" x 20" x 2-1/2" pan capacity, 5" casters (2 with brakes), aluminum, 120v/60/1-ph, 1440 watts, 12 amps, NEMA 5-15P, cULus, NSF		
	1 ea	1 year warranty against manufacturing defects		
			Freight: 300.00	300.00
			ITEM TOTAL:	4,099.00
7	1 ea	WORK TABLE, STAINLESS STEEL TOP	570.00	570.00
		 Advance Tabco Model No. ELAG-304C-X Special Value Work Table, 48"W x 30"D, 16 gauge 430 stainless steel top, 18 gauge galvanized adjustable undershelf, galvanized legs with casters, NSF		
			Freight: 75.00	75.00
			ITEM TOTAL:	645.00
8	2 ea	WORK TABLE, STAINLESS STEEL TOP	360.00	720.00
		 Advance Tabco Model No. ELAG-303-X Special Value Work Table, 36"W x 30"D, 16 gauge 430 stainless steel top, 18 gauge galvanized adjustable undershelf, galvanized legs with adjustable plastic bullet feet, NSF		
	2 st	TA-25G-4-X Special Value Casters, 5" diameter, set of 4 (2 with brakes) with galvanized legs for standard working height of 35-1/2"	195.00	390.00
			Freight: 71.00	142.00
			ITEM TOTAL:	1,252.00
9	1 ea	REACH-IN REFRIGERATOR	5,310.00	5,310.00
		 Beverage Air Model No. HBR49HC-1 Horizon Series Refrigerator, reach-in, two-section, 46.15 cu. ft. capacity, electronic control, (2) solid hinged self-closing doors (lockable), (6) epoxy coated wire shelves, LED lighting, adaptive defrost, bottom mounted self-contained refrigeration, stainless steel interior & exterior, R290 Hydrocarbon refrigerant, 1/3 HP, cULus, UL EPH Classified, UL-Sanitation, Made in USA		
	1 ea	3 years parts & labor warranty (excludes maintenance items)		
	1 ea	Self-Contained refrigeration		
	1 ea	Additional 4 years compressor warranty (part only), standard		

Item	Qty	Description	Sell	Sell Total
	1 ea	115v/60/1-ph, 5.0 amps, cord with NEMA 5-15P		
	1 ea	Left door hinged left, right door hinged on right, standard		
	1 ea	6" Heavy duty casters (2) locking, standard		
			Freight: 500.00	500.00
			ITEM TOTAL:	5,810.00
10	2 ea	TRAY RACK DISPENSER	2,599.00	5,198.00
		 Piper Products/Servolift Eastern Model No. PT/915MO2 Mobile Tray Dispenser, solid bottom, double stack, self-leveling, holds (300) 10-3/4" x 15-1/4" trays, with corner bumpers, stainless steel all tubular frame, NSF		
	2 ea	1 year warranty parts and labor from date of purchase		
	2 st	-Y4 Polyurethane 4" casters, set of 4, with ball bearing seals	112.00	224.00
			Freight: 135.00	270.00
			ITEM TOTAL:	5,692.00
11	2 ea	COMMERCIAL WASTE CONTAINER	48.00	96.00
		 Rubbermaid Commercial Products Model No. FG263256GRAY Packed 6 ea BRUTE® Food Processing Container, without lid, 32 gallon, 22"D x 27-1/4"H, with "Inedible" black imprint, reinforced rims, built in handles, double rimmed base, high-impact plastic construction, gray, NSF, Made in USA		
	2 ea	FG263100GRAY BRUTE® Container Lid, 22-1/4"D x 1-3/8"H, for 32 gallon trash can, heavy duty plastic, gray, NSF, Made in USA	15.00	30.00
	2 ea	FG264000BLA Brute® Dolly, 18-1/4"D x 6-5/8"H, heavy duty 3" casters, 250 lb. capacity, for 2620, 2632, 2643, 2655, black, NSF, Made in USA (CANNOT BREAK CASE)	50.00	100.00
			Freight: 50.00	100.00
			ITEM TOTAL:	326.00
11	2 ea	CART, BUSSING UTILITY TRANSPORT, METAL WIRE	439.00	878.00
		 Metro Model No. MW403 MW Standard Duty Utility Cart, MW400 series, open design (3) shelves, (2) wire (1) solid, shelf size 36"W x 18"D, chrome plated steel frame with (2) push handles, with (4) swivel/ resilient tread casters, NSF		
			Freight: 100.00	200.00
			ITEM TOTAL:	1,078.00
12	120 dz	COMPARTMENT TRAY	61.00	7,320.00
		 G.E.T. Enterprises Model No. TR-152-RO Packed 1 dz School & Cafeteria Tray, 14-3/8" x 9-7/8", 6 compartments, right-handed, ABS, rio orange		

Item	Qty	Description	Sell	Sell Total
	120 dz	NOTE: 8% surcharge included per each line item		
			ITEM TOTAL:	7,320.00
13	6 ea	CAN OPENER Edlund Model No. 2 Packed 6 ea Can Opener, manual, #2™ table style with plated steel base (for standard # 10 cans up to 7" tall), "Old Reliable"™	109.00	654.00
				
	6 ea	1 year limited warranty, standard		
			Freight:	5.00 30.00
			ITEM TOTAL:	684.00
14	2 ea	BUSSING UTILITY TRANSPORT CART Rubbermaid Commercial Products Model No. FG450088BLA Utility Cart, 39"L x 17-7/8"W x 33-1/4"H, 500 lb. capacity, (2) shelves, open base, polyethylene exterior, (2) fixed and (2) swivel 5" thermoplastic (TPR) casters, assembly required, black, Made in USA	205.00	410.00
				
			Freight:	50.00 100.00
			ITEM TOTAL:	510.00
15		COMMENT Freight Quotes are estimates only, and will be charged accordingly based on the freight cost at the time of delivery. Due to supply chain and logistics conditions, freight quotes cannot be guaranteed. Freight includes drop shipment to customer location. Customer is responsible for receiving, setting in place and any utility hook-ups needed. Sales tax to be added at time of purchase.		
			Subtotal	72,890.00
			Total	72,890.00

Prices Good Until: 07/20/2022

*****TERMS*****

- *Quote for equipment and products valid through date shown above.
- *Any changes will negate this quote (including freight). Changes include but are not limited to quantities and omission/addition of an item.
- *Prices are quoted per manufacturer's standard specification and do not include any optional accessories unless specified.
- *Order may be subject to credit approval and may require a deposit.
- *Shipping/Handling, lift gate, installation, delivery, "set in place" or applicable sales tax are not included unless noted
- *If not ordering lift-gate or installation, Please plan to remove equipment from the shipping carrier.
- *Please have a storage plan if items need to be held prior to installation.
- *Any changes to delivery time and location may impact additional shipping and storage fees that will be added to customer invoice.

*All returns are subject to restock fee plus freight

*Final Pricing may change due to increases in vendor pricing, surcharges, freight or fees between the time of initial quote and when the order is placed. The customer will be notified by MWRS of any changes prior to the order being processed.

*All accounts with balance over 30 day terms will be assessed a monthly finance charge equaling 18% APR

Acceptance: _____ Date: _____
Printed Name: _____

 REFRIGERATOR MANUFACTURER Turbo air more durable, efficient, beautiful	4184 E. Conant St. Long Beach, CA 90808 Tel. 310-900-1000 Fax. 310-900-1077 www.turboairinc.com	Project:	
		Model #:	
		Item #:	
		Available W/H:	Qty:
		Approval:	
		AIA #:	SIS #:
		CSI Section 11400	

Solid Door Freezer

Reach-In Bottom Mount
Super Deluxe Series

Model : TSF-72SD-N

≡ FEATURES & BENEFITS ≡

■ Self-Cleaning Condenser

The accumulation of dust in the condenser can cause the failure or breakdown of refrigerators. Refrigerators run normally until they reach a certain level of accumulation. At some point, when they are over the limit, their performance drops quickly resulting in damage to, or disposal of the stored products inside. The Self-Cleaning Condenser device keeps the condenser clean and prevents system failure by automatically brushing daily.

■ Digital temperature control & monitor system

- Keep food products safe by maintaining constant temperatures.
- Alarms that sound when doors are not sealed shut; protect against food spoilage that originates from cold air leaks.
- Early warning alarm program detects issues before malfunction occurs.
- Digital display allows for easy monitoring.
- Programs interpret the condition of refrigeration systems by self-diagnosis.
- Rapid cool-down function (Turbo Freeze).
- Smart defrost system will defrost as needed.
- Automatic evaporator fan motor delays.

■ Hydrocarbon refrigerants (R-290)

With innovative and eco-friendly technology, Turbo Air brings you hydrocarbon refrigerators designed to meet DOE's Energy Conservation Standards in 2017 and to use EPA's SNAP Program approved HC refrigerants. Hydrocarbon refrigerants do not deplete the ozone layer and have very low contribution to global warming (ODP-0, GWP-3).

■ Stainless steel cabinet construction

The Turbo Air Super Deluxe model boasts a stainless steel interior and exterior (galvanized steel top, bottom and back). It guarantees the utmost in cleanliness and long product life. Sharp corners and edges have been rounded to reduce the risk of injury. The Super Deluxe adds a touch of style to the most refined setting.

■ Sturdy, clean stainless steel shelving

Shelves are the most important part of cleanliness as they come in direct contact with food. After a while, PVC coated wire shelves may peel, rust and lead to unsanitary conditions. Only the Turbo Air Super Deluxe series uniquely provides stainless steel shelving.

■ Door pressure release device

Pressure relief doors are designed to eliminate vacuum pressure and allow easy, instant door opening.

■ High-density polyurethane insulation

The entire cabinet structure and solid doors are foamed-in-place using high density, HCFC free polyurethane insulation.

■ LED interior lighting

■ Bottom mount compressor

■ Freezer holds -10°F ~ 0°F for the best in frozen food preservation



Patented Self-Cleaning Condenser



This product is equipped with a fine mesh filter to the front of the condenser to catch dust, and a rotating brush that moves up and down daily to remove excess buildup outward and away.



ENERGY STAR®
Qualified

Model	Swing Door	CU./FT.	#of Shelves	HP	AMPS	Crated Weight (lbs.)	L x D x H* (inches)
TSF-72SD-N	3	63.8	9	3/4	6.5	650	81 7/8 x 30 3/8 x 78 1/4

Solid Door Freezer

Reach-In Bottom Mount
Super Deluxe Series

Model : TSF-72SD-N

ELECTRICAL DATA	
Voltage	115/60/1
Plug Type	 NEMA 5-20P
Full Load Amperes	6.5
Compressor HP	3/4
Feed Wires with Ground	4
Cord Length (ft.)	7
Refrigerant	R-290
DIMENSIONAL DATA	
# of Doors	3
# of Racks Accepted	3
Net Capacity (cu. ft.)	63.8
Ext. Length Overall (in.)	81 7/8 (2080mm)
Ext. Depth Overall (in.)	30 3/8 (770mm)
Ext. Height Overall (in.)*	78 1/4 (1987mm)
Int. Length Overall (in.)	77 7/8 (1979mm)
Int. Depth Overall (in.)	26 1/4 (666mm)
Int. Height Overall (in.)	60 (1524mm)
# of Shelves	9
Shelf Size (L x D) (in.)	24 1/2 x 23 1/2
Gross Weight (lbs.)	650

Design and specifications subject to change without notice.

Actual shipping weight may differ due to extra packing materials for product protection.

* Height does not include 5" caster height or 6" optional legs.

■ WARRANTY : 3 Year Parts and Labor Warranty Additional 4 Year Warranty on Compressor

■ STANDARD FEATURES

- Anti-corrosion coated evaporator
- Door locks standard
- Positive seal self-closing doors
- Easy replaceable one piece magnetic door gaskets
- Self-contained system
- Solid and sturdy grille design
- Standard 4" dia. swivel casters with locks on the front set

■ OPTIONAL ACCESSORIES

- 5" caster, 1/2" diameter & 13 TPI: M726500100 (non-brake), M726500200 (w/ brake)
- 6" stainless steel leg: 30221M0600
- Additional stainless steel shelf: 30278Q0210
- Half door bun tray rack: TSP-2224 (each holds up to six 18"L x 26"D sheet pans)
- Full door bun tray rack: TSP-2250 (each holds up to fifteen 18"L x 26"D sheet pans)

Ver.20210422

PLAN VIEW

(unit : inch)

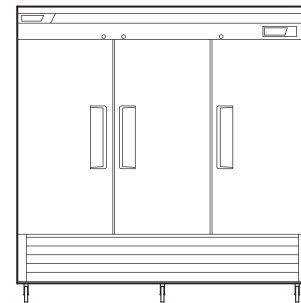

FRONT VIEW

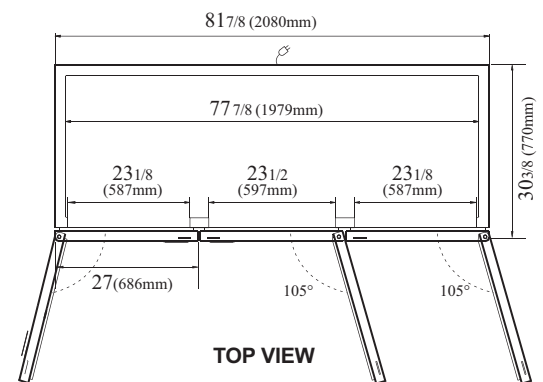

TOP VIEW

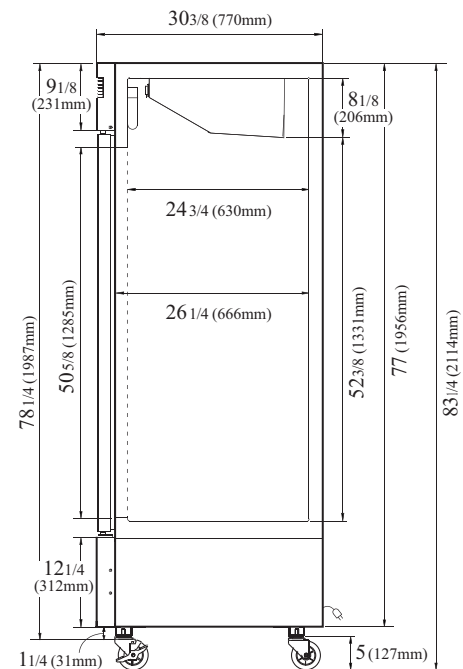

SIDE VIEW



- Turbo Air : 800-627-0032
- GK : 800-500-3519
- Warranty : 800-381-7770
- AC : 888-900-1002

Turbo air

GERMAN KNIFE

RADIANCE

Turbo air

TEXAKING

Continued product development may necessitate specification changes without notice.

	4184 E. Conant St. Long Beach, CA 90808 Tel. 310-900-1000 Fax. 310-900-1077 www.turboairinc.com		Project :
			Model # :
	Item # :	Qty :	
	Available W/H :		
	Approval :		

Pan Racks



TSP-2250

≡ FEATURES & BENEFITS ≡

- Full / half size pan rack
- Fits in full door for refig & freezers (TSP-2250)
- Fits in pizza prep or solid door refig & freezers (TSP-2224)
- 304 stainless steel construction
- Resists corrosion in high moisture refrigerated environments



TSP-2224

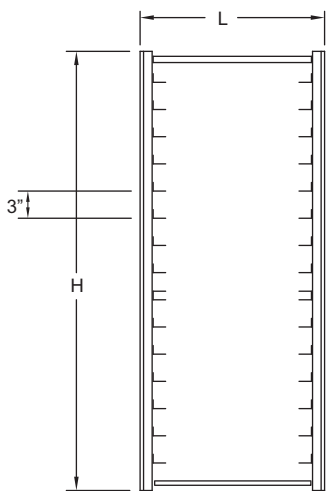

TSP-2250 FRONT VIEW

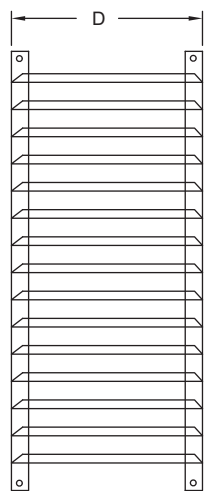

TSP-2250 SIDE VIEW

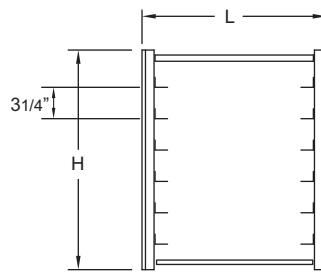

TSP-2224 FRONT VIEW

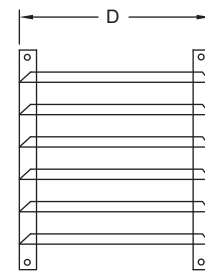

TSP-2224 SIDE VIEW

Model*	L	D	H	Shelf/Ledge Spacing	Capacity (18 x 26 size sheet pan)	Weight (lbs.)†
TSP-2250	21	24	50	3 (76mm)	15	41
TSP-2224	21	24	22 1/2	3 1/4 (83mm)	6	19

Ver.20191010

Information and specifications are subject to change without notice.

* All units shipped knocked-down.

† All weights are approximated. Crafting fee will be added for shipping via common carriers (Please confirm at the time of the purchase).

Project: _____

Item #: _____

Panasonic

NE-3280 SONIC STEAMER

**FOOD SERVICE
EQUIPMENT****PRO2**www.panasonic.com/CM0

MEET YOUR NEW PREP COOK

NO WATER LINE OR RESERVOIR | NO HOOD REQUIRED | PORTABLE | 3200 WATT

Powered by microwave technology | Top and bottom energy feed with 4 magnetrons
Holds two full-size 4" tall steam pans with covers | 16 customized programs **SONIC
STEAMER** 日本製
MADE IN JAPAN**the POWER of STEAM****EFFICIENT, FAST AND PRECISE HEAT YIELDS A SUPERIOR-QUALITY PRODUCT****Super green broccoli | Perfectly cooked seafood | Gently steamed buns**

Ideal for heavy-volume steaming and microwave applications in restaurants, supermarkets, delicatessens, school food service, health care, banquets and buffets, catering services, arenas and large venues.

NE-3280 SONIC STEAMER

Panasonic FOOD SERVICE EQUIPMENT

www.panasonic.com/CMO

WHY SONIC STEAMER?

High wattage allows the steamer to deliver effective, accurate heat that leaves products perfectly cooked. No soggy, brown broccoli here!

CULINARY PERFORMANCE

Category	Product	Minute/Lb	Yield/Hour
Seafood	Shrimp	1:30	40
	Lobster	2-2:30	35
	Fish	2:40	20
Vegetable	Asparagus	0:55	72
	Potato	2:30	60
	Green Beans	1:40	42
	Broccoli	2:15	45
Meat	Meatballs	2:40	40
	Hot Dogs	1:00/dozen	52 dozen

SPECIFICATIONS	NE-3280
Power Source:	208/230-240V, 60Hz, Single Phase
Receptacle Required:	30 Amp, NEMA 6-30
Frequency:	2,450MHz
Required Power:	208V (28.0A), 230V (25.3A)
Output:	3200 Watts*
Outer Dimensions: (w x d x h)	25 3/8" x 20 3/4" x 18 9/16"
Cavity Dimensions: (w x d x h)	21-1/16" x 13" x 9-7/8"
Net Weight:	137 lbs.
Shipping Weight:	151 lbs.
Shipping Box Size: (w x d x h)	29-7/8" x 26-1/8" x 22-1/4" 9.9 cu.ft.
Timer:	Maximum times for each stage of cooking: - Hi and Med. Power = 15 minutes - Low, Defrost and Hold Power = 60 minutes
Memory Capability:	16 Programs

Find more recipes, applications and suggested cook times in our **Sonic Steamer Cookbook**. Free online!

The NE-2180 commercial microwave meets or exceeds all safety performance and sanitation standards set for commercial food service microwave ovens by UL, HHS, FCC and NSF.



NEMA 6-30



Panasonic Commercial Food Service

Division of Panasonic Corporation of North America
2 Riverfront Plaza | Newark, NJ 07102
(201) 348-7000

www.panasonic.com/cmo

PERFORMANCE

- 3 stage cooking
- 5 power levels (HI, MED, LOW, DEF, HOLD)
- 8 programmable memory pads
– 16 total memory capability
- Timer: maximum times for power levels:
– Hi+Med: 15 minutes
– Low, Def., Hold: 60 minutes
- Programmable / dial timer to select cooking time

ADDITIONAL FEATURES

- XL oven capacity of 1.6 cu.ft.
- Drop down "grab and go" door
- Stainless steel cabinet & cavity
- See-through oven door
- Removable center shelf
- Digital display
- 4 heating elements (magnetrons)
- Top and bottom energy feed
- Holds two 4" tall full-size steam pans with covers

MAINTENANCE

- Self-diagnostics
- Easy to clean air filters
- Easy to change interior oven light
- Warranty: 3 years parts and labor
3 years magnetron

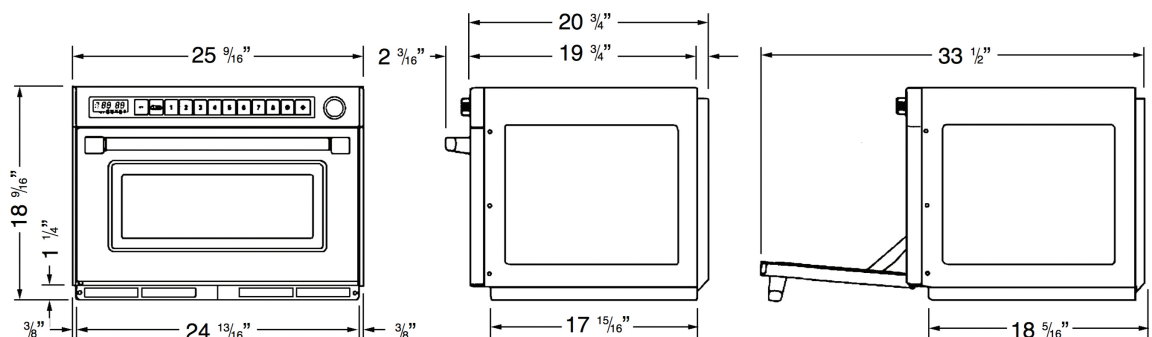



4184 E. Conant st., Long Beach, CA 90808
Tel. 800-500-3519 Fax. 310-900-1066
www.turboairinc.com

Project :

Model # :

Item # :

Qty :

Available W/H :

Approval :

24" Wide Heavy Duty Restaurant Ranges

**Model : TAR-4
TAR-4-LP**



≡ FEATURES & BENEFITS ≡

- Heavy gauge welded frame construction
- Fully adjustable oven thermostat providing temperatures from 250-550°F degrees
- Stainless steel front, sides, back riser lift-off high shelf
- Pull out stainless steel door for easy cleaning
- Individual pilot for each lift off top open burner at 32,000 btu/hr
- Thermostat controlled griddle
- 6" stainless steel adjustable legs (casters available as an option)
- 1 stainless steel oven rack standard (additional racks optional)
- 12" x 12" sectioned heavy duty cast iron grates
- CSA certified for safety / sanitation for USA and Canada
- Full size pull out crumb tray
- Wrap around full stainless steel oven interior / 26.3" depth standard



Model	Oven	Weight (lbs.)	Width (inches)	Total BTUs	Configuration
TAR-4	1	360	24	163K	4 open burners (NAT)
TAR-4-LP	1	360	24	160K	4 open burners (LPG)

Ver.20200921

24" Wide Heavy Duty Restaurant Ranges

Model : TAR-4

DATA	TAR-4
Gas Type	NAT
Gas Connection	3/4"
Regulator	3/4"
Gas Pressure	5 W.C"
BTU	163,000
DIMENSIONAL DATA	
Ext. Length Overall (inch)	24 (610mm)
Ext. Depth Overall (inch)	31 7/8 (810mm) + manifold
Ext. Height Overall (inch)	56 1/2 (1436mm)
OVEN DIMENSION (Interior)	
Number of Oven	1
Length (inch)	20 1/8 (510mm)
Depth (inch)	26 1/4 (669mm)
Height (inch)	13 5/8 (345mm)
Weight (lbs.)	360

DATA	TAR-4-LP
Gas Type	LPG
Gas Connection	3/4"
Regulator	3/4"
Gas Pressure	10 W.C"
BTU	160,000
DIMENSIONAL DATA	
Ext. Length Overall (inch)	24 (610mm)
Ext. Depth Overall (inch)	31 7/8 (810mm) + manifold
Ext. Height Overall (inch)	56 1/2 (1436mm)
OVEN DIMENSION (Interior)	
Number of Oven	1
Length (inch)	20 1/8 (510mm)
Depth (inch)	26 1/4 (669mm)
Height (inch)	13 5/8 (345mm)
Weight (lbs.)	360

Design and specifications subject to change without notice.
Actual shipping weight may differ due to extra packing materials for product protection.

■ WARRANTY : 1 Year Labor and Parts Warranty

■ OPTIONAL ACCESSORIES :

- Casters (Set of 4)
- Stainless steel oven racks
- Holder Set, Oven Kick Plate: RCP1126

PLAN VIEW

(unit : inch)

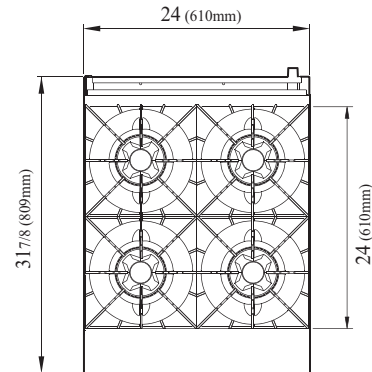

TOP VIEW

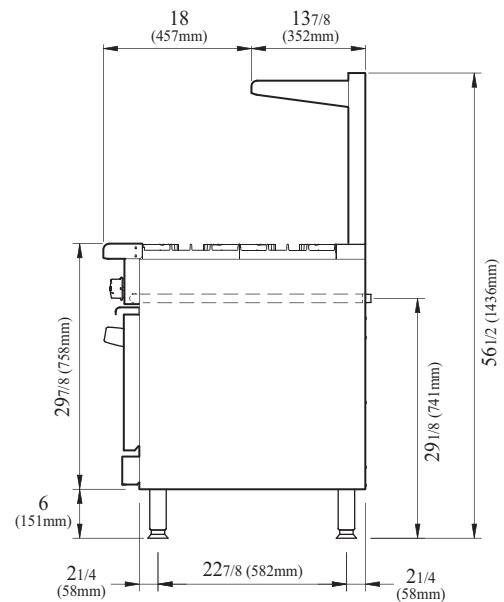

SIDE VIEW

Ver.20200921



- Turbo Air : 800-627-0032 ■ GK : 800-500-3519
- Warranty : 800-381-7770 ■ AC : 888-900-1002

turbofan®

30D SERIES

G32D5

Technical data sheet for

G32D5 ON THE SK32 STAND

Full Size Digital / Gas Convection Oven
on a Stainless Steel Stand



G32D5 OVEN



G32D5

Unit shall be a Moffat gas heated Turbofan convection oven NSF-4 and E.T.L. listed. The oven shall have a one piece porcelain enameled oven chamber, stainless top and sides and safe touch vented easy clean side hinged door that offers field reversible hinging. Oven shall have capacity for five full size sheet pans. The oven shall be controlled by an electronic control having separate digital displays and adjusting knobs for time and temperature functions. The oven control shall allow both manual and programmed operating modes with programmable moisture injection and 3 stage cooking. A core temperature probe M236060 is optional. The unit shall include dual halogen oven lamps. Oven shall be able to be bench mounted on 3" / 76mm feet or mounted on oven stand model SK32. Unit shall be supplied in 100% recyclable shipping packaging. This unit shall be Energy Star certified.

SK32

Unit shall be a Moffat Turbofan stainless steel oven stand NSF-4 listed. The stand shall be constructed from stainless steel tube with castors, with front castors having dual swivel and wheel locks. It shall be fitted with 6 tray runners suitable for up to 12 half size sheet pans or 6 full size sheet pans. The stand shall be fully compatible with, and support, Turbofan Convection Oven models E32D and G32D. Unit shall be supplied in 100% recyclable shipping packaging.

STANDARD FEATURES

- 5 full size sheet pan capacity
- 3½" / 85mm tray spacing
- Compact 28⅞" / 735mm width
- 110-120V plug-in
- 15A NEMA 5-15P cordset fitted
- Digital display Time and Temperature Controls
- Large easy view ¾" / 20mm high displays
- Electronic thermostat control
- Electronic burner ignition and safety control system
- Electronic timer with countdown or time count modes
- Manual mode and Program mode
- 20 programs with 3 stage cooking and stage end alarms
- Core Probe program cooking (optional Core Probe Kit)
- Moisture injection mode (5 levels) and manual injection
- Bi-directional reversing fan system
- 33,000 Btu/hr patented Infrared burner system
- Safe-Touch vented side hinged door (standard LH hinge). Optional RH hinge (field convertible)
- Stay-Cool door handle
- Porcelain enameled oven chamber
- Plug-in continuous oven door seal
- Dual halogen oven lamps
- Anti-skid 2" / 50mm dia. 4" / 102mm high adjustable stainless steel feet
- 5 oven wire racks supplied
- 100% recyclable packaging

ACCESSORIES

- Turbofan SK32 Oven Stand
- Optional M236060 Core Temp Probe Kit

turbofan®

30D SERIES

G32D5

G32D5 Full Size Digital / Gas Convection Oven on a Stainless Steel Stand

CONSTRUCTION

Porcelain enameled fully welded oven chamber
Stainless steel front, sides and top exterior
Stainless steel oven fan baffle and oven vent
Removable 5 position stainless steel side racks
Oven racks chrome plated wire (5 supplied)
Stainless steel frame side hinged door
0.2" / 5mm thick door outer glass
0.2" / 5mm thick low energy loss door inner glass
Full stainless steel welded door handle
Stainless steel control panel
Aluminized coated steel base and rear panels

CONTROLS

Electronic controls with Digital Time and Temperature display, Manual or Program modes
Large ¾" / 20mm high LED displays
Two individual time and temperature setting control knobs
ON/OFF key
Oven Lights key
Timer Start/Stop key
Moisture Injection key (5 levels)
Programs select key
Actual temperature display key
Adjustable buzzer/alarm volume
Thermostat range 150-500°F / 50-260°C
Timer range from 180 minutes in countdown mode
Timer range up to 999 minutes in time count mode for holding, slow cooking
Direct burner ignition control flame failure safety control
Optional Core Probe temperature range 122-194°F / 50-90°C
Over-temperature safety cut-out

CLEANING

Stainless steel top and side exterior panels
Porcelain enameled oven chamber
Fully removable stainless steel oven side racks
Removable stainless steel oven fan baffle
Easy clean door system with hinge out door inner glass (no tools required)
Removable plug-in oven door seal (no tools required)
3" / 76mm high stainless steel feet for easy access underside

SPECIFICATIONS

Electrical Requirements
110-120V, 60Hz, 1-phase, 1A
NEMA 5-15P cordset fitted

Gas Requirements

33,000 Btu/hr / 35MJ/hr burner rating
Natural, Propane/Butane models

Unit supplied complete with gas type conversion kit

Gas Connection

½" NPT male

Water Requirements (optional)

Cold water connection ¾" GHT male

80psi maximum inlet pressure / 20psi minimum inlet pressure



External Dimensions

Width 28⅞" / 735mm
Height 35⅞" / 910mm including 4" / 102mm feet
Depth 31⅞" / 810mm

Oven Internal Dimensions

Width 18¼" / 465mm
Height 20¼" / 515mm
Depth 27½" / 700mm
Volume 6ft³ / 0.17m³

Oven Rack Dimensions

Width 18" / 460mm
Depth 26" / 660mm

Nett Weight (G32D5)

250lbs / 113kg

SK32 Stainless Steel Stand

All stainless steel welded frame oven stand for Turbofan E32D and G32D Series ovens

6 position tray runners standard
3" / 76mm diameter wheel swivel castors standard with 2 front castors with dual swivel and wheel
Welded 1½" and 1¼" square tube front and rear frames
Welded rack supports/side frames
4 dia. 3" / 76mm swivel castors with 2 front castors dual wheel and swivel lock
Top frame oven supports suit Turbofan E32D and G32D Series oven mounting
Supplied CKD for assembly on site

External Dimensions (SK32 Oven Stand)

Width 28⅞" / 735mm
Height 34⅞" / 880mm
Depth 25⅞" / 650mm
Nett Weight (SK32 Oven Stand)
40lbs / 18.5kg

Packing Data

Oven (G32D5)
289lbs / 131kg
25ft³ / 0.71m³

Width 29⅞" / 760mm
Height 39¾" / 1010mm
Depth 36⅞" / 925mm

Oven Stand (SK32)

51lbs / 23kg
3.5ft³ / 0.1m³
Width 32⅞" / 830mm
Height 35½" / 900mm
Depth 6" / 152mm

INSTALLATION CLEARANCES

	NON-COMBUSTIBLE SURFACES	COMBUSTIBLE SURFACES
Rear	3" / 75mm	3" / 75mm
LH Side	2" / 50mm	2" / 50mm
RH Side*	3" / 75mm	3" / 75mm

* For fixed installations a minimum of 20" / 500mm is required for service

CLEARANCE FROM SOURCES OF HEAT

A minimum distance of 12" / 300mm from the appliance sides is required

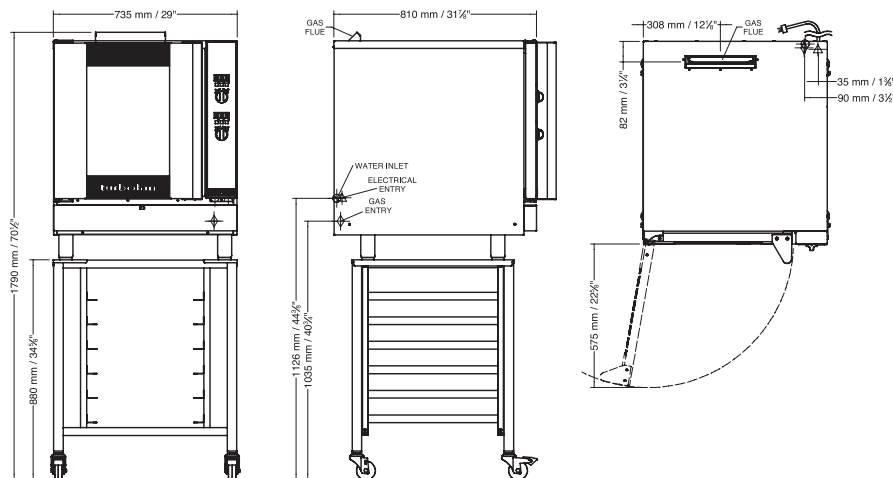

G32D5 OVEN



www.moffatusa.com
www.turbofanoven.com

U.S.A.

Moffat Inc
3765 Champion Boulevard
Winston-Salem
North Carolina 27105
Ph Toll Free 1-800-551 8795
Ph 336-661 0257
Fax 336-661 9546
Email sales@moffat.com
www.moffatusa.com



ISO9001
Quality
Management
Standard

Designed and manufactured by



ISO9001

All Turbofan products are designed and manufactured by Moffat using the internationally recognised ISO9001 quality management system, covering design, manufacture and final inspection, ensuring consistent high quality at all times.

In line with policy to continually develop and improve its products, Moffat Limited reserves the right to change specifications and design without notice.



© Copyright Moffat Ltd
US.TFN.S.1601

February 2016

CROWN VERITY

ECONOMY HAND SINK

CV-EHS, EHS-E

Project: _____

Item #: _____

Quantity: _____



CV-EHS

Our Economy hand sink provides more than 300 hand washes and offers an extra large wash basin, soap and papertowel dispensers as well as hands-free foot pump operation. Simple to service thanks to easy - flow drainage, roll and go wheels and a slim storage profile. Available in two configurations cold and (EHS-E) warm water wash.

SPECIFICATIONS

Model	CV-EHS	CV-EHS-E
Weight empty	50 Lbs.	50 Lbs.
Weight Full	189 Lbs.	189 Lbs.
Fresh Water Capacity	15 Gal.	15 Gal.
Gray Water Capacity	19 Gal.	19 Gal.
Overall Dimensions	18" W x 22" D x 62" H	18" W x 22" D x 62" H

SPECIFICATIONS

- Moves like a hand truck - use the built-in handle to tilt the economy sink back onto its wheels and roll away
- Heavy duty, non marking rubber wheels make drop off and pickup a breeze
- Lightweight - only 189 Lbs. when filled with water
- Nearly 300 uses on a single, 15 gallon fill up
- Drain hose included for hassle-free, quick clean out
- Easy to store thanks to slim profile
- Extra large basin allows for full forearm immersion
- Foot pump for hygenic "hands-free" operation

More Standard Features

- Liquid soap and paper towel dispensers included
- Warm water model reaches 110°F



CV-EHS-E

Page 1/1

37 Adams Boulevard
Brantford Ontario N3S 7V8

T 519 751 1800
F 519 751 1802

crownverity.com
info@crowverity.com

BRILLIANT ANYWHERE



We put space to work.

Item # _____

Job _____

Metro C5[®] 3 Series Insulation Armour[®] Heated Holding and Proofing Cabinets

- **Insulation Armour™:** Patented insulation technology retains heat, saves energy, and provides a cool-to-touch exterior. Durable polymer construction is dent, impact, and stain resistant. Molded-in hand holds create vertical handles for mobile applications.
- **Colors:** Insulation Armour is available in Red, Blue, or Gray standard and in other colors on a promotional basis or upon request.
- **Control:** Three modules are available: Holding, Moisture, and Combination Proof and Hold. All feature an easy-to-read digital thermometer, recessed control dials, a master on/off switch, and power indicator lights. All are removable without tools for easy cleaning, and allow for future upgrades without replacing entire cabinet body.
- **Performance:** All modules provide fast heat-up and recovery through a thermostatically controlled, forced convection system.
- **Sizes:** C5 3 Series cabinets are available in Full Height (71", 1803mm), ³/₄ Height (59", 1499mm), ¹/₂ Height (44", 1118mm), and Under Counter (32", 813mm) sizes.
- **Doors:** Solid insulated aluminum or clear polycarbonate doors are available. Full Height cabinets can be configured with full length or dutch-style doors. Clear doors provide visibility of the contents of the cabinet without the heat loss associated with opening the door.
- **Capacity:** Three slide styles provide maximum holding capacity. Choose from Universal Wire, Lip Load, or Fixed Wire.
- **Reliability:** Reliability and durability are designed into every C5. High-quality components provide a long life of worry free use.
- **Power Options:** Choose between standard high wattage or low wattage models based on the specific needs of the application.



**Red Full
Height
Dutch
Clear Doors**



**Red
Under
Counter
Solid Door**

**Blue
¹/₂ Height
Full Solid
Door**

**Gray
³/₄ Height
Full Clear
Door**

**Blue
Full Height
Full Clear
Door**



3 Series Removable Control Modules

- **Holding Module:** Hot holding at higher temperatures without moisture control.*
- **Moisture Module:** Hot holding and proofing. Moisture control at any temperature.
- **Combination Module:** Hot holding and proofing. Moisture control at lower temperatures (proofing).

* Note: Cabinets with holding module do not include the water pan.

All Metro Catalog Sheets are available on our website: www.metro.com

Metro Heated cabinets are for hot food holding applications only.



InterMetro Industries Corporation
North Washington Street, Wilkes-Barre, PA 18705
Product Information. U.S. and Canada: 1.800.992.1776
Outside U.S. and Canada: www.metro.com/contactus

L03-270
Printed in U.S.A. Rev. 11/18

Information and specifications are subject to change without notice. Please confirm at time of order.

Copyright © 2018 InterMetro Industries Corp.



C5[®] 3 Series Insulation Armour[®] Heated Holding and Proofing Cabinets

13-93

Job _____

13.93



We put space to work.

C5[®] 3 Series Insulation Armour[®] Heated Holding and Proofing Cabinets

C5[®] 3 Series Insulation Armour[®] Heated Holding and Proofing Cabinets

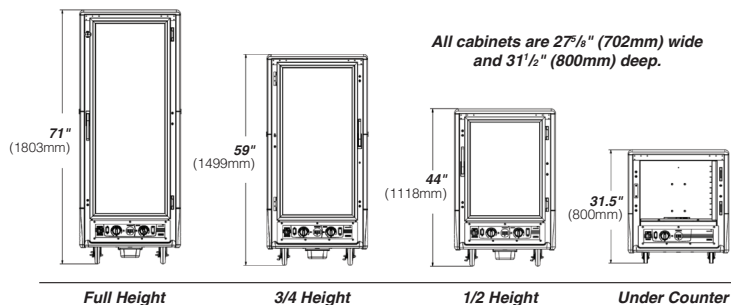

- Cabinet Material:** .063" (1.8mm) aluminum, natural interior with .125" (3.2mm) aluminum chassis.
- Insulation Armour™:** High Density Polyethylene (HDPE).
- Casters:** Four casters with 5" (127mm) donut neoprene wheel, double ball bearing swivel, ball bearing axel, nickel plated, two with brake. 3" rubber casters on Under Counter models.
- Solid Doors:** Fully insulated with 1" (25.4mm) fiberglass, double panel .063" (1.8mm) aluminum, brushed exterior, natural interior.
- Clear Doors:** Extruded aluminum powder coated frame with .090" (2.3mm) polycarbonate window.
- Hinges:** Field reversible, double hinged, 180° swing, with long-life nylon bearings.
- Gaskets:** High temperature, door mounted, Santoprene gaskets.
- Latches:** Polymer high-strength magnetic pull latch with lever-action release.
- Hand Holds:** Molded into the Insulation Armour™ on all four corners.
- Universal Slides:** 1/4" (6.4mm) dia. nickel-chrome electroplated wire, adjustable on 1/2" (38mm) increments.
- Lip Load Slides:** 1 1/2"x1/2"x.063" (38x38x1.8mm) extruded aluminum channel slides, 1 1/2" (38mm) fixed spacing.
- Fixed Wire Slides:** 1/4" (6.4mm) dia. nickel-chrome electroplated wire, welded on 3" (76mm) spacing. Not offered in Under Counter models.
- Drip Trough:** Smooth polymer drip trough with catch pan.
- Holding Modules:** Removable without tools, digital thermometer, recessed control dials, master on/off switch, "Power On" light, water pan, ball bearing blower forced air system, 7 1/2' cord, UL, CUL, and NSF Listed.

Electrical and Performance:

- Holding Module:** 80°F (27°C) to 200°F (93°C) operating temperature range. Available: 120V 2000W & 1440W, 220-240V 1681-2000W.
- Moisture Module:** 80°F (27°C) to 200°F (93°C) operating temperature range. 35% RH at 160°F (71°C), 95% RH at 95°F (35°C). Available: 120V 2000W, 220-240V 1681-2000W.
- Combination Module:** 80°F (27°C) to 200°F (93°C) operating temperature range. 95% RH at 95°F (35°C). Available: 120V 2000W & 1440W, 220-240V 1681-2000W.
- Clearance Requirements:** 18" (46cm) away from any cooking equipment. AVOID contact with surfaces that exceed 200°F (90°C). Minimum clearance from enclosures is 1 1/2" (38mm) on sides and back, 1/2" (12.7mm) on top.

Cabinet Height
 9 = Full Height
 7 = 3/4 Height
 5 = 1/2 Height
 3 = Under Counter

Module Type
 C = Combination
 M = Moisture
 H = Heated Holding

Slide Type
 U = Universal Wire
 4 = Fixed Wire
 L = Lip Load Aluminum

C539-CDC-U

NEMA 5-20P
 For Standard Wattage Cabinets (120V, 16A, 60Hz, 2000W)

Door Style
 FS = Full Length Solid
 FC = Full Length Clear
 DS = Dutch Solid *
 DC = Dutch Clear *

* Please note: Dutch doors only available on full-height models. Cabinets ordered without a color designation default to Red.

Low Watt Model Number Description

C539-CLDC-U

NEMA 5-15P Add "L" for Lower Wattage Combination or Holding Module Cabinets (120V, 12A, 60Hz, 1440W)

Note: Under Counter holding and combination module cabinets are only available in low watt. Under Counter moisture module cabinets are available in 120V, 2000W.

Export Model Number Description

C539-CXDC-U

NEMA 6-15P Add "X" for Export Cabinets (220-240V, 7.6-8.3A, 50/60Hz, 1681-2000W)

Blue or Gray Model Description

C539-CDC-U-BU

** Cabinets ordered without a color designation default to Red.

Please Note: Under Counter Cabinets are only offered in Red & Gray.

Color **
 No Suffix = Red
 BU = Blue
 GY = Gray

Models with Accessories or Options

C539-CDC-UA ← An "A" suffix indicates that accessories need to be factory assembled to the cabinet. Order accessories separately.

C539-CDC-U-BUA

Please Note: Under Counter Combination & Holding modules are not available in 120V, 2000W.

- Options/Accessories***
- Small Item Shelf (C5-SHELF-S)
 - Stainless Steel Legs (C5-SSLEGS)
 - Universal Slide Pair, Chrome (C5-USLIDEPR-C)
 - 6" Casters (C5-6CASTER)
 - Rear Rigid Casters (C5-5RDGCSTR)
 - Travel Latch (C5-TRVL)
 - Flush Door Latch (C5-LATCHFLUSH-1)*
 - Straight Plug, 20 Amp, 120V (C5-STRPLG-20)
 - Straight Plug, 15 Amp, 120V (C5-STRPLG-15)
 - Factory Left-Hand Hinging (DD3768)
 - Stainless Steel Universal Slides (please call)

* Please note: (2) handles required for dutch door models

Pan Capacity	Universal Wire Slide					Lip Load Slide	Fixed Wire Slide	
	Slide Pairs	Sheet Pans	Steam Pans			Sheet Pans	Sheet Pans	Steam Pans
Cabinet Size	Provided	18"x26"	12"x20"x2.5" GN 1/1 65mm	12"x20"x4" GN 1/1 100mm	12"x20"x6" GN 1/1 150mm	18"x26"	18"x26"	12"x20"x2.5" GN 1/1 65mm
Full Height	18	18	34	24	14	35	18	34
Full Height Dutch	18	17	32	22	12	34	17	32
3/4 Height	14	14	26	16	10	27	14	26
1/2 Height	9	8	16	10	6	17	8	16
Under Counter	5	5	10	6	4	10	N/A	N/A

an Ali Group Company



The Spirit of Excellence



STAINLESS STEEL VALUE MOBILE WORK TABLES With Adjustable Undershef



Item #: _____ Qty #: _____
 Model #: _____
 Project #: _____

DETAILS and SPECIFICATIONS

TOL ± .500"

ALL DIMENSIONS ARE TYPICAL



FEATURES:

- Maintains standard 35-1/2" working height.
- Top is furnished with 1 5/8" sanitary rolled rim on front and rear and square ends.
- Two hat-channels stud welded under tabletop to reinforce and maintain a level work surface.
- Aluminum die cast "leg-to-shelf" clamp secures shelf to leg eliminating unsightly nuts and bolts.
- Undershef is fully adjustable.
- Includes 4 casters (2 with brakes).

CONSTRUCTION:

- All TIG welded. Exposed weld areas polished to match adjacent surface.
- Top is sound deadened.
- Roll formed embossed galvanized hat channels are secured to top by means of structural adhesive and weld studs.
- Gussets welded to support hat channels.

MATERIAL:

- TOP:** 16 gauge stainless steel type "304" series.
- SHELF:** 18 gauge galvanized steel.
- LEGS:** 1 5/8" diameter tubular galvanized steel. Galvanized steel gussets.

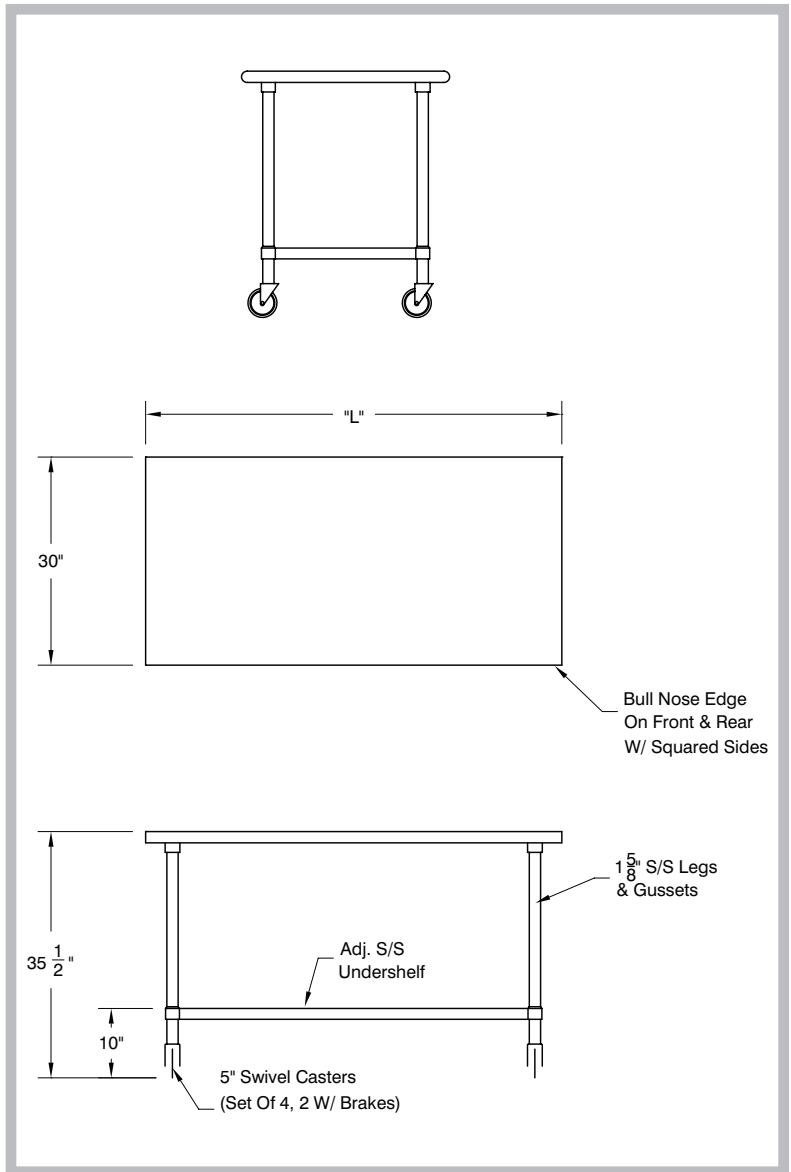

30" WIDE	L	Model #	WT.	Cu. Ft.
	FLAT TOP			
48"	ELAG-304C-X	93 lbs.	7	
60"	ELAG-305C-X	111 lbs.	8	
72"	ELAG-306C-X	128 lbs.	10	



Customer Service Available To Assist You 1-800-645-3166 8:30 am - 8:00 pm E.S.T.

For Orders & Customer Service:
 Email: customer@advancetabco.com or Fax: 631-242-6900

For Smart Fabrication™ Quotes:
 Email: smartfab@advancetabco.com or Fax: 631-586-2933



STAINLESS STEEL ECONOMY WORK TABLES



FEATURES:

ELAG Top is furnished with 1 5/8" sanitary rolled rim on front and rear & square ends.

FLAG Top is furnished with 1 5/8" sanitary rolled rim on front and square ends, and 1 1/2" backsplash on rear.

KLAG Top is furnished with 1 5/8" sanitary rolled rim on front and square ends, and 5" backsplash at rear.

Two hat-channels stud welded under tabletop to reinforce and maintain a level work surface.

Aluminum die cast "leg-to-shelf" clamp secures shelf to leg eliminating unsightly nuts and bolts. Underself is fully adjustable.

CONSTRUCTION:

All TIG welded. Exposed weld areas polished to match adjacent surface.

Top is sound deadened.

Roll formed embossed galvanized hat channels are secured to top by means of structural adhesive and weld studs.

Gussets welded to support hat channels.

MATERIAL:

TOP: 16 gauge stainless steel type "430" series.

SHELF: 18 gauge galvanized steel.

LEGS: 1 5/8" diameter tubular galvanized steel. Galvanized steel gussets.
1" adjustable plastic bullet feet.

Item #: _____ Qty #: _____
 Model #: _____
 Project #: _____



Plastic Bullet Feet standard on ELAG, FLAG & KLAG Series



	L	Model #	Cu.		WT.	Ft.	Cu.		WT.	Ft.	Model #	Cu.		WT.	Ft.
			WT.	Ft.			WT.	Ft.							
			FLAT TOP			1 1/2" SPLASH			5" SPLASH						
18" WIDE	24"	ELAG-182-X	37 lbs.	4	-	-	-	-	-	-	-	-	-	-	-
	30"	ELAG-180-X	44 lbs.	4	-	-	-	-	-	-	-	-	-	-	-
	36"	ELAG-183-X	47 lbs.	4	-	-	-	-	-	-	-	-	-	-	-
	48"	ELAG-184-X	58 lbs.	5	-	-	-	-	-	-	-	-	-	-	-
	60"	ELAG-185-X	66 lbs.	7	-	-	-	-	-	-	-	-	-	-	-
	72"	ELAG-186-X	79 lbs.	8	-	-	-	-	-	-	-	-	-	-	-
24" WIDE	24"	ELAG-242-X	44 lbs.	4	FLAG-242-X	44 lbs.	4	KLAG-242-X	48 lbs.	7					
	30"	ELAG-240-X	50 lbs.	4	FLAG-240-X	50 lbs.	4	KLAG-240-X	55 lbs.	7					
	36"	ELAG-243-X	56 lbs.	4	FLAG-243-X	56 lbs.	4	KLAG-243-X	61 lbs.	7					
	48"	ELAG-244-X	69 lbs.	6	FLAG-244-X	69 lbs.	6	KLAG-244-X	75 lbs.	9					
	60"	ELAG-245-X	80 lbs.	7	FLAG-245-X	80 lbs.	7	KLAG-245-X	89 lbs.	11					
	72"	ELAG-246-X	95 lbs.	8	FLAG-246-X	95 lbs.	8	KLAG-246-X	102 lbs.	13					
	84"	ELAG-247-X	108 lbs.	10	FLAG-247-X	108 lbs.	10	KLAG-247-X	117 lbs.	15					
	96"	ELAG-248-X*	112 lbs.	11	FLAG-248-X*	112 lbs.	11	KLAG-248-X*	137 lbs.	17					
30" WIDE	24"	ELAG-302-X	49 lbs.	5	FLAG-302-X	49 lbs.	5	KLAG-302-X	53 lbs.	8					
	30"	ELAG-300-X	56 lbs.	5	FLAG-300-X	56 lbs.	5	KLAG-300-X	61 lbs.	8					
	36"	ELAG-303-X	64 lbs.	5	FLAG-303-X	64 lbs.	5	KLAG-303-X	69 lbs.	8					
	48"	ELAG-304-X	79 lbs.	7	FLAG-304-X	79 lbs.	7	KLAG-304-X	84 lbs.	11					
	60"	ELAG-305-X	95 lbs.	8	FLAG-305-X	95 lbs.	8	KLAG-305-X	101 lbs.	13					
	72"	ELAG-306-X	110 lbs.	10	FLAG-306-X	110 lbs.	10	KLAG-306-X	117 lbs.	16					
	84"	ELAG-307-X	125 lbs.	12	FLAG-307-X	125 lbs.	12	KLAG-307-X	133 lbs.	18					
	96"	ELAG-308-X*	131 lbs.	13	FLAG-308-X*	131 lbs.	13	KLAG-308-X*	140 lbs.	20					
36" WIDE	36"	ELAG-363-X	73 lbs.	6	FLAG-363-X	73 lbs.	6	-	-	-					
	48"	ELAG-364-X	92 lbs.	8	FLAG-364-X	92 lbs.	8	-	-	-					
	60"	ELAG-365-X	111 lbs.	10	FLAG-365-X	111 lbs.	10	-	-	-					
	72"	ELAG-366-X	130 lbs.	12	FLAG-366-X	130 lbs.	12	-	-	-					
	96"	ELAG-368-X*	158 lbs.	15	FLAG-368-X*	158 lbs.	15	-	-	-					

All 8 ft. Tables Provided With 6 Legs



Customer Service Available To Assist You **1-800-645-3166** 8:30 am - 8:00 pm E.S.T.

For Orders & Customer Service:

Email: customer@advancetabco.com or Fax: 631-242-6900

For Smart Fabrication™ Quotes:

Email: smartfab@advancetabco.com or Fax: 631-586-2933



DETAILS and SPECIFICATIONS

TOL ± .500"

ALL DIMENSIONS ARE TYPICAL

ELAG SERIES - Flat Top

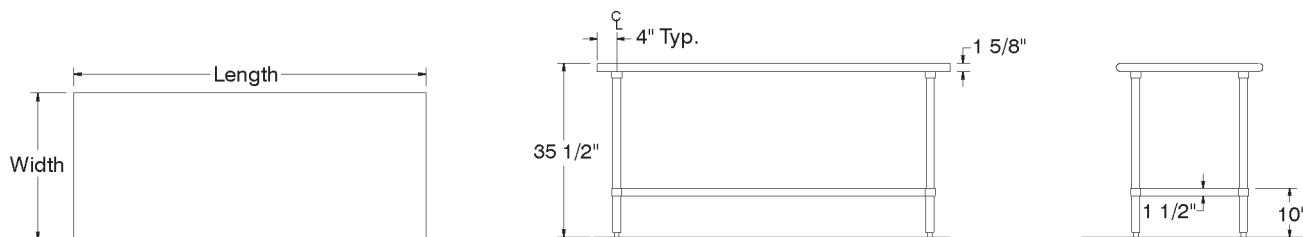

FLAG SERIES - 1 1/2" Backsplash

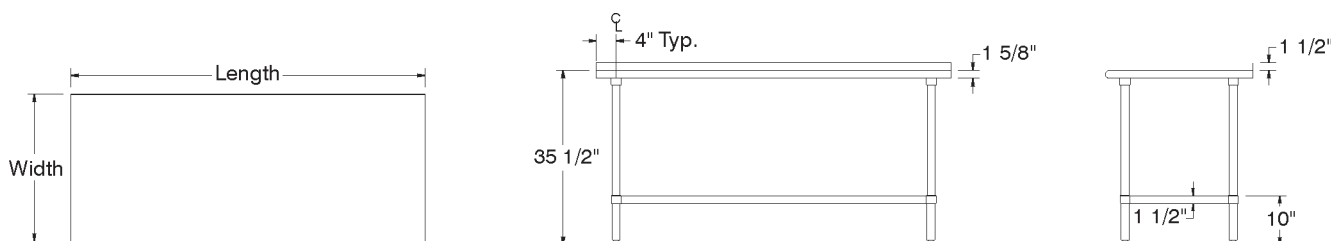

KLAG SERIES - 5" Backsplash

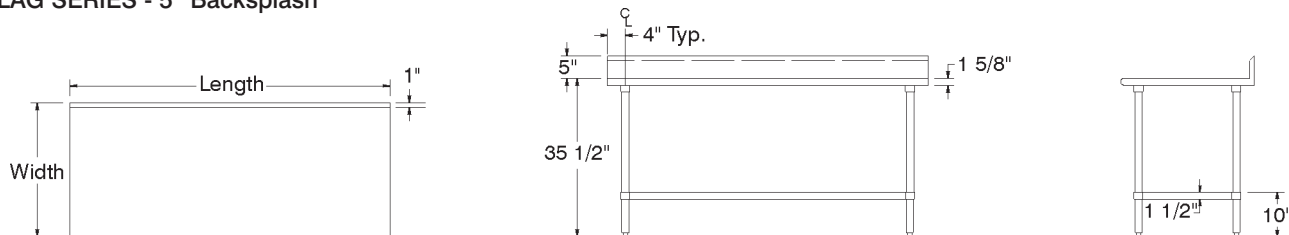



TABLE MODIFICATIONS & ACCESSORIES

TOP MODIFICATIONS



TA-56
5" NSF Partition



TA-523
Drop-In Urn Trough



CDR-5
Condiment Holder

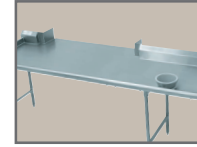

TA-84
Pass-Thru



TA-108
Grommet For Cords

QTY.

_____	CDR-5	Condiment Holder (Accommodates 5 Bins)
_____	TA-1	Notch Backsplash For Roll Up Door w/ Pass-Thru
_____	TA-3	Stainless Steel Hat Channel & Gusset Upgrade
_____	TA-7	10" Partial Splash
_____	TA-8	Column Notch in Rear Splash (Includes Splash)
_____	TA-10	5" Partial Splash
_____	TA-12	Countertop Edge
_____	TA-22	Square Edge Table
_____	TA-28	Cut-Out For Cold Well. Includes Louvered Doors
_____	TA-29	16 Ga. 304 Rear Splash Capping Strip w/Adhesive Backing
_____	TA-30	1-1/2" Side Splash
_____	TA-30A	1-1/2" Turn Up For Table Tops
_____	TA-31	5" Side Splash
_____	TA-32	10" Side Splash
_____	TA-34	Top Cut-Out
_____	TA-34A	Top Cut-Out for Undermount Well
_____	TA-35	Splash Cut-Out
_____	TA-41	Poly-Vance 5/8" Cutting Board
_____	TA-56	5" NSF Partition
_____	TA-56A	18" NSF Partition
_____	TA-57	Prepare Welded Field Joint (Welded in field by others)
_____	TA-57A	Bolted Field Joint (Bolted in field by others)
_____	TA-57B	Hairline Field Joint
_____	TA-58	Stepdown to 24" Working Height
_____	TA-64	Urn Trough (Factory installation only)
_____	TA-75	Mitered Edge
_____	TA-76	Paint on Sound Deadening
_____	TA-79	Flour Trough (Factory installation only)
_____	TA-82	Scrap Chute (6" dia. opening)
_____	TA-84	Simple Pass-Thru
_____	TA-87	Enclosed Rear Splash
_____	TA-91	Poly Retaining Clips Includes TA-22 (S/S top table)

QTY.

_____	TA-93	Wall Brackets (Includes 2. For 5" & 10 1/2" splash only)
_____	TA-96A	Can Opener Provision for Openers with Bolt-on Base (Customer to provide location)
_____	TA-96B	Can Opener Surface Mount Provision with 4" S/S Tube for Openers w/o Base (Customer to provide location)
_____	TA-96C	Can Opener Spacer Plate Provision for Use on Tables With Countertop Edge & Can Opener Base (Customer to provide location)
_____	TA-100	Bull Nose All Sides of Worktable
_____	TA-101	Rear Tray Lock
_____	TA-106	Mirror HI-LITE Edge
_____	TA-107	Vacuum Breaker Holes on Tables (Includes Backsplash with 2" Return)
_____	TA-108	2" Hole with Grommet for Appliance Cord
_____	TA-112	Hubble Outlet
_____	TA-113	Notch Top for Buyout Unit
_____	TA-130	Cutlery Dispenser Holder (Undercounter Mounted)
_____	TA-135	Plate Shelf (Undercounter Mounted)
_____	TA-366A	Heavy duty Understructure Top
_____	TA-502	Install Advance Tabco Hot Food Unit In Work Table Top (Requires TA-34 Top Cut-Out & TA-27 Control Panel. Does not include wiring. Consult factory)
_____	TA-521	Drop-In urn Trough 1'
_____	TA-522	Drop-In urn Trough 2'
_____	TA-523	Drop-In urn Trough 3'
_____	TA-524	Drop-In urn Trough 4'
_____	TA-525	Drop-In urn Trough 5'
_____	TA-526	Drop-In urn Trough 6'
_____	TA-527	Drop-In urn Trough 7'
_____	TA-528	Drop-In urn Trough 8'
_____	TA-529	Drop-In urn Trough 9'
_____	TA-550	Install Customer Supplied Buyout Items (Does not include wiring. Consult factory)
_____	TA-551	Installation of Hot Food Wells. (Requires TA-34 Top Cut-Out & TA-27 Control Panel. Does not include wiring. Consult factory)



Customer Service Available To Assist You **1-800-645-3166** 8:30 am - 8:00 pm E.S.T.

For Orders & Customer Service:

Email: customer@advancetabco.com or Fax: 631-242-6900

For Smart Fabrication™ Quotes:

Email: smartfab@advancetabco.com or Fax: 631-586-2933



TABLE MODIFICATIONS & ACCESSORIES

BASE MODIFICATIONS



TA-39
Louvered Hinged Doors



TA-73
Drop-Down Tray Slide



TA-74
Solid Tray Slide



TA-900
ADJ. Height Tables



TA-116
Adj. Mid-Shelf

QTY.

- ___ **TA-4** Removable Access Panel
- ___ **TA-4A** Louvered Panel
- ___ **TA-5** Curb Mounting Provision
- ___ **TA-15** Provision for Built In Drawer Warmer
- ___ **TA-23** Welded Set-Up Table/Crating
- ___ **TA-24** Shell Crating
- ___ **TA-27** Control Panel (Must add TA-34A or TA-34B)
- ___ **TA-36A** Sliding/Hinge Stainless Steel Doors
- ___ **TA-36B** 1/2 Height Stainless Steel Hinge Doors
- ___ **TA-36C** Hinged door with Trash Flap
- ___ **TA-37** Stainless Enclosed Base
- ___ **TA-39** 24" Louvered Hinged Doors
- ___ **TA-40** Remove Undershef in Cabinet Base For Slide in Buyout
- ___ **TA-42** Interior Partition (2.5"x30")
- ___ **TA-43** Filler Panel (3"x30" with Flanged Feet)
- ___ **TA-44** K.D. Aluminum Pan Rack Slides (6 slides. Table min. lgth. 30")
- ___ **TA-45** K.D. Aluminum Glass Rack Slides (3 slides. Table min. lgth. 3 feet)
- ___ **TA-46** Door Locks

QTY.

- ___ **TA-48** 12"x12" Cut-Out in Back Panel/Undershef for Plumbing
- ___ **TA-54** Removable Kick Plate
- ___ **TA-55** Remove Back Panel (on Enclosed Base)
- ___ **TA-63** Removable Shelving (In addition to standard shelf & table width)
- ___ **TA-70** S/S Tubular Tray Divider (12" sections)
- ___ **TA-73** Tubular Tray Slide w/Dropdown (Stationary Tray Slide Available. Factory installation only)
- ___ **TA-74** Solid Tray Slide
- ___ **TA-92** 12" Apron (in front of sink)
- ___ **TA-92A** 17" Stainless Steel Apron to Cover Sink Bowls and Support Lever Drain Handles
- ___ **TA-116** Adjustable Enclosed Base Cabinet Mid Shelf- Add to Price of Enclosed Base Table with Fixed Mid Shelf (M). Shelves Over 36" In Length Require Multiple Sections With Center Partition. For Partial Shelves Add To Price Of Shelf.
- ___ **TA-130** Cutlery Dispenser Holder (Undercounter Mounted)
- ___ **TA-135** Plate Shelf (Undercounter Mounted)
- ___ **TA-205** Connect Cafeteria Items (Per Joint Between 2 Tables. Requires Casters)
- ___ **TA-900** Upgrade Table To be Height Adjustable In Field (Up to 6" Only. Unit Ships Set Up)

ELECTRICAL & DATA PORT OUTLETS



TA-62
Duplex Outlet



TA-62A
GFI Duplex Outlet



TA-62D
GFI Doghouse Outlet



TA-62F
Empty Junction Box



TA-112
Hubble Outlet

QTY.

- ___ **TA-62** Standard Duplex Electrical Outlet & Cover Plate (Under Flat Top). NEMA 5-15R
- ___ **TA-62A** GFI Duplex Outlet & Cover Plate in a VKS Splash. NEMA 5-20R
- ___ **TA-62C** GFI Duplex Outlet & Cover Plate Below Shelf Top. NEMA 5-20R
- ___ **TA-62D** GFI Duplex Outlet & Cover Plate in a Doghouse. NEMA 5-20R

QTY.

- ___ **TA-62E** Upgrade Outlet to a NEMA 6-20R or Equiv.
- ___ **TA-62F** Junction Box (empty) Below Table Top. Includes 1 Gang Size, Stainless Steel Face Plate
- ___ **TA-112** Hubble Outlet
- ___ **TA-622** CAT-5 Data Port Outlet. Cable Not Included



Customer Service Available To Assist You 1-800-645-3166 8:30 am - 8:00 pm E.S.T.

For Orders & Customer Service:

Email: customer@advancetabco.com or Fax: 631-242-6900

For Smart Fabrication™ Quotes:

Email: smartfab@advancetabco.com or Fax: 631-586-2933



TABLE MODIFICATIONS & ACCESSORIES

OVERSHELF & POT RACK MODIFICATIONS

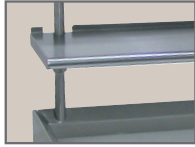

TA-9A
1" Turn Up



TA-22A
Square Edge



TA-71
Heat Lamp Mounting Provision



TA-100A
Bull Nose

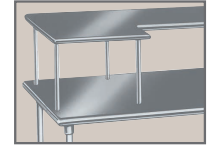

TA-102
24" x 24" Extension

QTY.

_____	TA-9A	Partial 1" Turn-Up for all Table Mt. Shelves
_____	TA-22A	Square Edge on Oversheff
_____	TA-26-10	Welded Wall Shelf Brackets for 10" Wide Shelf
_____	TA-26-12	Welded Wall Shelf Brackets for 12" Wide Shelf
_____	TA-26-15	Welded Wall Shelf Brackets for 15" Wide Shelf
_____	TA-26-18	Welded Wall Shelf Brackets for 18" Wide Shelf
_____	TA-47	Shelf Mounting Bracket for Existing Table
_____	TA-49	Wall Shelf 2" Offset
_____	TA-60	Special Sizing Charge for Shelves (Must Order Larger Unit to be Cut Down to Smaller Size)
_____	TA-71	Heat Lamp Mounting Provision
_____	TA-71A	Heat Lamp Remote Control Bracket
_____	TA-78	Additional Lin. Ft. Past 12' For Table Mt. Shelf (For ODS, OTS, TS, DS & WS Shelving only)
_____	TA-77	Check Minder Shelf Provision (Factory install only)
_____	TA-83	Spice Bins

QTY.

_____	TA-84A	Knife Rack for Rolled Rim Tables
_____	TA-84B	Knife Rack for Poly Top Tables
_____	TA-84C	Knife Rack for Square Edge Tables
_____	TA-86	Stainless Steel Pot Hooks
_____	TA-89	Double Sided Plated Pot Hooks (Package of 4)
_____	TA-89A	Single Sided Plated Pot Hooks (Package of 4)
_____	TA-98	Stainless Steel Flat Bar in lieu of Chain
_____	TA-99	16 Ga. S/S 304 Upgrade for Wall & Over Shelves
_____	TA-100A	Bull Nose All Sides of Shelf
_____	TA-100R	Bull Nose Three Sides of Shelf w/ Rear Turn Up
_____	TA-102	24" x 24" Extension for Microwave or Computer Shelf (Add to OTS and ODS Shelves. See page 65)
_____	TA-103	24" Wide PT Shelf (36" Min Length. Mid mount only. PT Series Shelf, See Pg. 73. Add to 18" Wide Shelf)
_____	TA-104	Additional Length Over 12' (Add to 18" Shelf. (PA & CU Shelving Only. Max. Length is 14' as Single Piece)

UNDERSHELF MODIFICATIONS

QTY.

_____	TA-9	1-1/2" Turn-Up for Undershelves
_____	TA-17	Upgrade Undersheff to a Marine Edge (Must add TA-23)
_____	TA-48	12"x12" Cut-Out in Back Panel or Undersheff for Plumbing

QTY.

_____	TA-94	Upgrade 16 Ga. 304 S/S Undersheff
_____	TA-94A	Upgrade 14 Ga. 304 S/S Undersheff
_____	TA-366	Reinforced Understructure For Undershelves

SIZE MODIFICATIONS

QTY.

_____	TA-33	Special Working Height
_____	TA-59	36" Wide Equipment Stand
_____	TA-6	Extra Length for Standard Tables Over 12' (Tables Over 14' Require Field Joint TA-57)
_____	TA-61	Special Sizing Charge (Larger Unit Cut Down to Smaller Size)
_____	TA-61A	Special Modification Charge

QTY.

_____	TA-65	Enclosed Base Units Over 12' (Open Base Table)
_____	TA-66	Enclosed Base Units Over 12' (Sliding Door Units)
_____	TA-67	Enclosed Base Units Over 12' (Hinged Door Units)
_____	TA-105	Modify Enclosed Base Table w/ Drawers to 24" Width
_____	TA-110	Modify Enclosed Base Table w/ Drawers to 36" Width



Customer Service Available To Assist You **1-800-645-3166** 8:30 am - 8:00 pm E.S.T.

For Orders & Customer Service:

Email: customer@advancetabco.com or Fax: 631-242-6900

For Smart Fabrication™ Quotes:

Email: smartfab@advancetabco.com or Fax: 631-586-2933



TABLE MODIFICATIONS & ACCESSORIES

LEG MODIFICATIONS

QTY.			QTY.		
_____	TA-16	1 Galvanized Leg with Plastic Bullet Foot (34 1/2" Total Length)	_____	TA-20-6	6 Stainless Steel Leg with S/S Bullet Feet (34 1/2" Total Length)
_____	TA-16-4	4 Galvanized Legs with Plastic Bullet Feet (34 1/2" Total Length)	_____	TA-20L	Replacement Bolt-on Leg For Enclosed Base Table
_____	TA-16-6	6 Galvanized Legs with Plastic Bullet Feet (34 1/2" Total Length)	_____	TA-21	Stainless Steel Bullet Foot
_____	TA-19	Stainless Steel Flanged Bullet Foot For Work Table	_____	TA-68	Relocate Rear Cross Rail To Center (for Open Base Tables Only)
_____	TA-19L	S/S Bolt-on Leg w/ Flanged Foot For Enclosed Base Table	_____	TA-72	Leg to Wall Brace (Set per table)
_____	TA-20	1 Stainless Steel Leg with S/S Bullet Foot (34 1/2" Total Length)	_____	TA-95	Upgrade 16 Ga. 304 S/S Legs Only
_____	TA-20-4	4 Stainless Steel Leg with S/S Bullet Feet (34 1/2" Total Length)			

WORK TABLE CASTERS



Standard Casters

Maintains the Standard 35-1/2" Working Height

200 lbs. Load Capacity Per Caster

When Used w/ Stainless Steel Legs

TA-25S-4 Set of 4 (Two with Brakes)

TA-25S-6 Set of 6 (Two with Brakes)

When Used w/ Galvanized Legs

TA-25G-4 Set of 4 (Two with Brakes)

TA-25G-6 Set of 6 (Two with Brakes)

Replacement Casters

For Work Tables

TA-25 Set of 4 (Two with Brakes)

TA-25A Set of 6 (Two with Brakes)

200 lbs. Load Capacity Per Caster



Optional Standard Caster Upgrades:

- TA-25B Set For brakes on all wheels (Standard Casters) - Add price to the following models: TA-25, TA-25A, TA-25S-4, TA-25S-6, TA-25G-4, TA-25G-6
- TA-25C Per Caster Upgrade Standard Caster with Heavy Duty Urethane Wheels (Per Caster)

EQUIPMENT STAND CASTERS



Standard Casters

5" Urethane Wheels.

Maintains the Standard 24" Working Height

200 lbs. Load Capacity Per Caster

w/ Stainless Steel Legs

TA-25ES Set of 4 (Two with Brakes)

w/ Galvanized Legs

TA-25EG Set of 4 (Two with Brakes)

HEAVY DUTY Casters

5" Urethane Wheels

400 lbs. Load Capacity Per Caster

TA-255 Super Heavy Duty Set of 4 (Two with Brakes)

TA-256 Super Heavy Duty Set of 6 (Two with Brakes)



Enclosed Base Table Casters

Easy Bolt-On Style



TA-255P Set of 4 (Two with Brakes)

TA-255AP Set of 6 (Two with Brakes)

300 lbs. Load Capacity Per Caster

For brakes on all wheels (Enclosed Base Casters) - Add price to models: TA-255P or TA-255AP

TA-255PB

Optional Equipment Stand Caster Upgrade:

- TA-255B For brakes on all wheels (Equipment Casters) - Add price to any of the following models: TA-255, TA-256, TA-25ES, TA-25EG

Contact Our SMART FABRICATION™ Department for more information at 800-645-3166 or email in your specifications to smartfab@advancetabco.com



ADVANCE TABCO is constantly engaged in a program of improving our products. Therefore, we reserve the right to change specifications without prior notice.

© ADVANCE TABCO, AUGUST 2018



BEVERAGE-AIR

Project: _____	AIA#
Item: _____	
Location: _____	SIS#
Approved: _____	

HORIZON BOTTOM MOUNT REACH-IN

HBR49HC Solid Door Reach-In Refrigerator

Hydrocarbon Series

MODEL:
HBR49HC-1



3 Year Parts/Labor Warranty

Additional 4 Year Compressor Warranty

CABINET CONSTRUCTION

- Stainless steel front, side, and grille (galvanized back & bottom)
- Stainless steel interior
- LED lighting
- Full electronic control with one-touch defrost
- One-piece grille allow easy removal/installation for preventative maintenance
- Door locks (solid doors only)
- Self closing door with 120° stay open feature
- Spring-loaded style hinges
- Plug-in magnetic door gaskets
- Six (6) heavy duty epoxy coated wire shelves
- 6" Casters with two (2) brakes

OPTIONS & ACCESSORIES

- Stainless steel universal tray slide pair, 1 tray slide set for (1) 18" x 26" or (2) 14" x 18" pans (AC)
- Wine models
- 3" Casters or 6" legs
- Epoxy shelves
- Shelf clips
- Remote option* (see note on back page)

REFRIGERATION SYSTEM

- Uses environmentally friendly, energy efficient R290 refrigerant, and meets all regulatory requirements for CARB, SNAP, DOE & more
- Hot gas condensate evaporator
- Adaptive defrost
- Epoxy coated evaporator coil
- Maintains product temperatures between 36°-38° F

HBR49HC BOTTOM MOUNT REACH-IN REFRIGERATOR



Please verify qualifying units by visiting:
www.energystar.gov/cfs

3779 Champion Blvd., Winston-Salem, NC 27105
1-888-845-9800 Fax: 1-336-245-6453
Beverage-Air.com Sales@bevair.com



BEVERAGE-AIR

MODEL	HBR49HC-1
EXTERNAL DIMENSIONAL DATA	
Width Overall	52"
Depth Overall with Handle	33 3/4"
Height Overall	84 1/4"
Number of Doors	2
Depth with Door Open 90°	56 1/8"
Door Opening (in)	22 3/4" x 52 5/8"
INTERNAL DIMENSIONAL DATA	
NET Capacity (cubic ft.)	46.15
Internal Width Overall (in)	49"
Internal Depth Overall (in)	26"
Internal Height Overall (in)	61 5/8"
Internal Height Useable (in)	53"
Number of Shelves	6
ELECTRICAL DATA	
Full Load Amperes 115/60/1	5.4
REFRIGERATION DATA	
Horsepower	1/3
Capacity (BTU/Hr)	2392
Heat Rejection (BTU/Hr)	3588
Charge (lbs/grams)	0.2535/115
SHIPPING DATA	
Gross Weight - Crated	594 lbs
Height - Crated	88"
Width - Crated	56"
Depth - Crated	37"

*NOTE: Remote units are field wired and come with 6" legs. Refrigerant must be specified at time of order.

Bottom Mount Reach-In Refrigerator Model: HBR49HC-1

Model Views

Required Clearance: Rear 3"

PLAN VIEW

ELEVATION VIEW

SIDE VIEW

ELECTRICAL CONNECTION



**115/60/1
NEMA 5-15P**

Unit pre-wired at factory and include 8' long cord and plug set.



3779 Champion Blvd., Winston-Salem, NC 27105 1-888-845-9800 Fax: 1-336-245-6453 Beverage-Air.com Sales@bevair.com

an Ali Group Company



JOB _____ ITEM # _____ QTY # _____

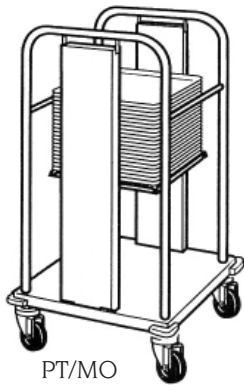

PT/MO



PT/MO2

PT/MO AND PT/MO2 SERIES

Piper's Self-leveling Mobile Tray Dispensers are offered in two styles; single or double stack, tubular frame with solid bottom. These Selfleveling Tray Dispensers can be found in tray lines, front- or back-of-the-house, or any place your needs require.

MOBILE TRAY DISPENSERS SPECIFICATIONS

Model#	Max. Tray Size	(A) Length	(B) Width	Height	Ship Wt. (lbs)
SINGLE					
<input type="checkbox"/> PT/915MO	10-3/4" x 15-1/8"	18-1/2"	14-15/16"	36-1/4"	58
<input type="checkbox"/> PT/1014MO	10-3/4" x 15-1/8"	18-1/2"	14-15/16"	36-1/4"	58
<input type="checkbox"/> PT/1216MO	12-3/8" x 16-3/4"	16-11/16"	19-7/8"	36-1/4"	58
<input type="checkbox"/> PT/1222MO	12-3/8" x 22-3/4"	16-11/16"	25-7/8"	36-1/4"	65
<input type="checkbox"/> PT/1418MO	14-3/8" x 18-3/4"	18-11/16"	21-7/8"	36-1/4"	68
<input type="checkbox"/> PT/1520MO	15-3/8" x 20-3/4"	19-11/16"	23-7/8"	36-1/4"	68
<input type="checkbox"/> PT/1622MO	16-3/8" x 22-3/4"	20-11/16"	25-7/8"	36-1/4"	80
<input type="checkbox"/> PT/2020MO	20" x 20"	20-1/2"	24-7/8"	36-1/4"	75
DOUBLE					
<input type="checkbox"/> PT/915MO2	10-3/8" x 15-1/4"	19-3/8"	25-1/8"	36-1/4"	80
<input type="checkbox"/> PT/1014MO2	10-3/8" x 15-1/4"	19-3/8"	25-1/8"	36-1/4"	80
<input type="checkbox"/> PT/1216MO2	12-3/8" x 16-3/4"	19-7/8"	32-9/16"	36-1/4"	98
<input type="checkbox"/> PT/1222MO2	12-3/8" x 22-3/4"	25-7/8"	32-9/16"	36-1/4"	105
<input type="checkbox"/> PT/1418MO2	14-3/8" x 18-3/4"	21-7/8"	36-9/16"	36-1/4"	87
<input type="checkbox"/> PT/1520MO2	15-3/8" x 20-3/4"	23-7/8"	38-9/16"	36-1/4"	105
<input type="checkbox"/> PT/1622MO2	16-3/8" x 22-3/4"	25-7/8"	40-9/16"	36-1/4"	109

NOTE: For bumpers add 1-1/2"

STANDARD FEATURES

- ◆ Equipped with self-lubricating delrin wheels and stainless steel extension springs that can be easily disconnected to adjust the lifting rate
- ◆ Self-leveling mechanism lifts out for easy cleaning
- ◆ Field adjustable to accommodate different weights
- ◆ Removable stainless steel carrier tray provides bottom support for trays being dispensed
- ◆ Base is fabricated of stainless steel and reinforced with stainless steel angles
- ◆ Tubular frames are fabricated from stainless steel tubing and securely welded to stainless steel angles on underside of base
- ◆ Tubular frames are reinforced by horizontal stainless steel rods welded to each vertical frame
- ◆ Non-marking bumper attached at each corner
- ◆ Four 4" heavy-duty non-marking swivel casters that are securely mounted to the base

WARRANTY

One year parts and labor. Warranty is detailed on inside front cover of the price list.

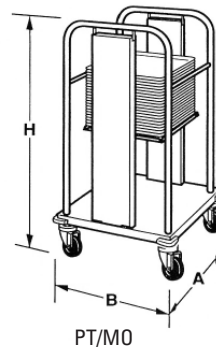

PT/MO

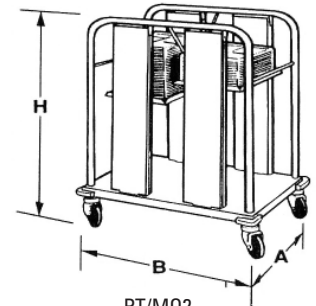

PT/MO2

OPTIONAL EQUIPMENT

- (WB) Two (2) Locking Casters
- (PB) Perimeter Bumper
- (Y4) 4" Polyurethane Casters
- (Y5) 5" Polyurethane Casters

LIMITED WARRANTY: PIPER PRODUCTS warrants to the original purchaser parts and labor for a period of twelve (12) months from the date of purchase. See manufacturer's complete warranty for details.

It is our policy to build equipment which is design certified by companies that have been accredited at the Federal Level by the Occupational Safety and Health Agency (OSHA) and ANSI as a National Recognized Testing Laboratory. These companies include CSA International, Underwriters Laboratories, and the National Sanitation Foundation. However, a continuing program of product improvement makes it necessary to submit new models to the agencies as they are developed. Consequently, all models may not bear the appropriate labels at all times.

We reserve the right to change specifications and product design without notice. Such revisions do not entitle buyer to corresponding changes, improvements, additions or replacements for previously purchased equipment. Information is not for design purposes.



PIPER PRODUCTS
BUILT TO LAST
www.piperonline.net

300 S. 84th Avenue
 Wausau, WI 54401
 Phone: 800-544-3057
 Fax: 715-842-3125



BRUTE® lids are constructed with the highest quality material; a UV inhibitor ensures long life in even the most extreme commercial environments. Lids come in a variety of different styles, including self-draining lids, dome top lids, and funnel lids to meet any commercial need.

Features and Benefits:

- Self-draining lids have channels that prevent water from pooling, reducing still water buildup, and include ridges that enable stacking to provide space-efficient storage
- Dome top lids have a spring action door that allows for easy trash disposal while keeping odors and insects out
- Self-draining lids and dome top lids both have a snap-lock feature that ensures a secure fit
- Funnel top lids have a cut-out top that enables hands-free refuse disposal and a funnel design that conceals waste from public view

BRUTE® LIDS

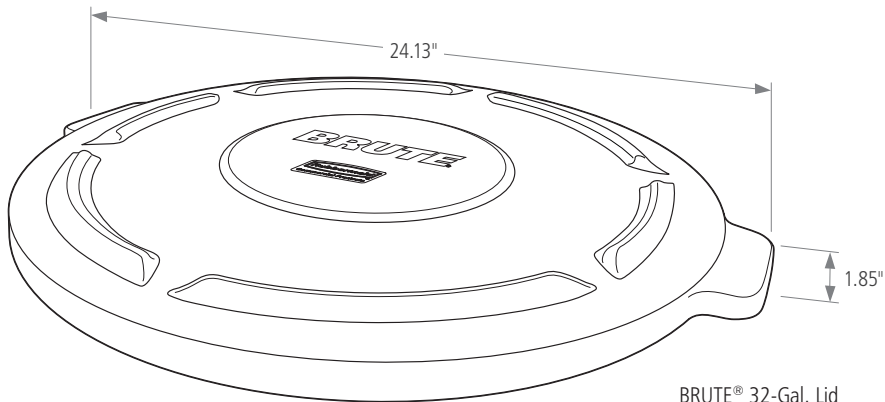

BRUTE® 32-Gal. Lid

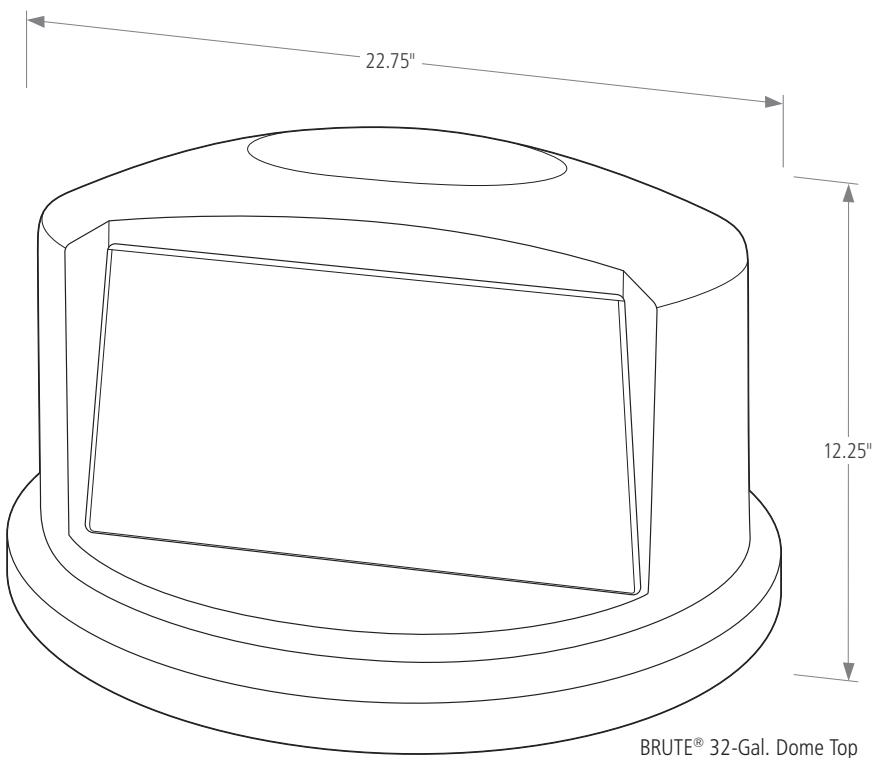

BRUTE® 32-Gal. Dome Top

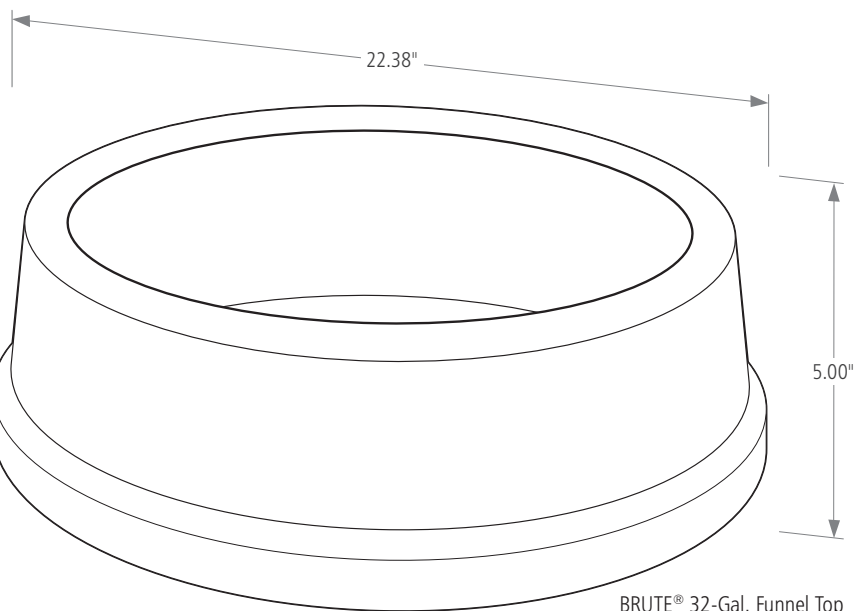

BRUTE® 32-Gal. Funnel Top

BRUTE® LIDS

SKU #	DESCRIPTION	COLOR	FITS	HEIGHT	DIAMETER	DIAMETER	PACK SIZE
				IN	IN	WITH HANDLE IN	
FG260900GRAY	BRUTE® 10 GALLON LID	GRAY	10G	1.25	15.88	17.13	6
FG260900WHT	BRUTE® 10 GALLON LID	WHITE	10G	1.25	15.88	17.13	6
FG260900RED	BRUTE® 10 GALLON LID	RED	10G	1.25	15.88	17.13	6
FG260900YEL	BRUTE® 10 GALLON LID	YELLOW	10G	1.25	15.88	17.13	6
1779700	BRUTE® 10 GALLON LID	BLUE	10G	1.25	15.88	17.13	6
FG260900DGRN	BRUTE® 10 GALLON LID	DARK GREEN	10G	1.25	15.88	17.13	6
1926826	BRUTE® 10 GALLON LID	BLACK	10G	1.25	15.88	17.13	6
FG261960GRAY	BRUTE® 20 GALLON LID	GRAY	20G	1.80	19.88	21.63	6
FG261960WHT	BRUTE® 20 GALLON LID	WHITE	20G	1.80	19.88	21.63	6
FG261960RED	BRUTE® 20 GALLON LID	RED	20G	1.80	19.88	21.63	6
FG261960YEL	BRUTE® 20 GALLON LID	YELLOW	20G	1.80	19.88	21.63	6
1779731	BRUTE® 20 GALLON LID	BLUE	20G	1.80	19.88	21.63	6
FG261960DGRN	BRUTE® 20 GALLON LID	DARK GREEN	20G	1.80	19.88	21.63	6
FG261960BLA	BRUTE® 20 GALLON LID	BLACK	20G	1.80	19.88	21.63	6
FG263100GRAY	BRUTE® 32 GALLON LID	GRAY	32G	1.85	22.38	24.13	6
FG263100WHT	BRUTE® 32 GALLON LID	WHITE	32G	1.85	22.38	24.13	6
FG263100RED	BRUTE® 32 GALLON LID	RED	32G	1.85	22.38	24.13	6
FG263100YEL	BRUTE® 32 GALLON LID	YELLOW	32G	1.85	22.38	24.13	6
FG263100BLUE	BRUTE® 32 GALLON LID	BLUE	32G	1.85	22.38	24.13	6
FG263100DGRN	BRUTE® 32 GALLON LID	DARK GREEN	32G	1.85	22.38	24.13	6
1867532	BRUTE® 32 GALLON LID	BLACK	32G	1.85	22.38	24.13	6
FG264560GRAY	BRUTE® 44 GALLON LID	GRAY	44G	2.00	24.25	26.75	4
FG264560WHT	BRUTE® 44 GALLON LID	WHITE	44G	2.00	24.25	26.75	4
FG264560RED	BRUTE® 44 GALLON LID	RED	44G	2.00	24.25	26.75	4
FG264560YEL	BRUTE® 44 GALLON LID	YELLOW	44G	2.00	24.25	26.75	4
1779636	BRUTE® 44 GALLON LID	BLUE	44G	2.00	24.25	26.75	4
FG264560DGRN	BRUTE® 44 GALLON LID	DARK GREEN	44G	2.00	24.25	26.75	4
FG264560BLA	BRUTE® 44 GALLON LID	BLACK	44G	2.00	24.25	26.75	4
FG265400GRAY	BRUTE® 55 GALLON LID	GRAY	55G	2.09	26.75	29.13	3
FG265400WHT	BRUTE® 55 GALLON LID	WHITE	55G	2.09	26.75	29.13	3
FG265400RED	BRUTE® 55 GALLON LID	RED	55G	2.09	26.75	29.13	3
FG265400YEL	BRUTE® 55 GALLON LID	YELLOW	55G	2.09	26.75	29.13	3
1779733	BRUTE® 55 GALLON LID	BLUE	55G	2.09	26.75	29.13	3
FG265400DGRN	BRUTE® 55 GALLON LID	DARK GREEN	55G	2.09	26.75	29.13	3
1779738	BRUTE® 55 GALLON LID	BLACK	55G	2.09	26.75	29.13	3
FG263788GRAY	BRUTE® 32 GALLON DOME TOP	GRAY	32G	12.25	22.75	–	1
FG263788RED	BRUTE® 32 GALLON DOME TOP	RED	32G	12.25	22.75	–	1
1829397	BRUTE® 32 GALLON DOME TOP	DARK GREEN	32G	12.25	22.75	–	1
1829398	BRUTE® 32 GALLON DOME TOP	BLUE	32G	12.25	22.75	–	1
1829399	BRUTE® 32 GALLON DOME TOP	YELLOW	32G	12.25	22.75	–	1
FG264788GRAY	BRUTE® 44 GALLON DOME TOP	GRAY	44G	12.63	24.88	–	1
FG264788RED	BRUTE® 44 GALLON DOME TOP	RED	44G	12.63	24.88	–	1
1834838	BRUTE® 44 GALLON DOME TOP	DARK GREEN	44G	12.63	24.88	–	1
1834839	BRUTE® 44 GALLON DOME TOP	YELLOW	44G	12.63	24.88	–	1
1834840	BRUTE® 44 GALLON DOME TOP	BLUE	44G	12.63	24.88	–	1
FG265788GRAY	BRUTE® 55 GALLON DOME TOP	GRAY	55G	14.50	27.25	–	1
FG265788RED	BRUTE® 55 GALLON DOME TOP	RED	55G	14.50	27.25	–	1
FG354300GRAY	BRUTE® 32 GALLON FUNNEL TOP	GRAY	55G	5.00	22.38	–	4





BRUTE® DOLLIES

BRUTE® dollies are designed to be durable, long-lasting, and are able to withstand the toughest commercial environments while simplifying everyday tasks.

Features and Benefits:

- Rugged casters help keep fully loaded BRUTE® containers stable, even on rough and uneven floors, and swivel smoothly for easy maneuvering
- Twist locks hold containers securely in place and unlock easily for unloading, allowing for easy transport
- Structural foam construction provides superior strength and durability

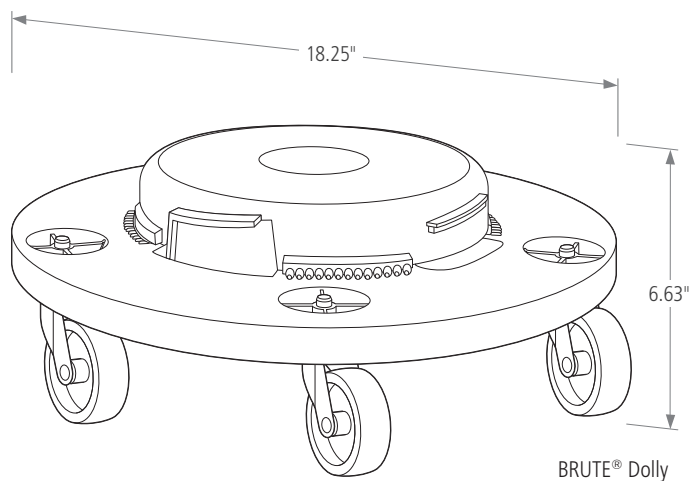
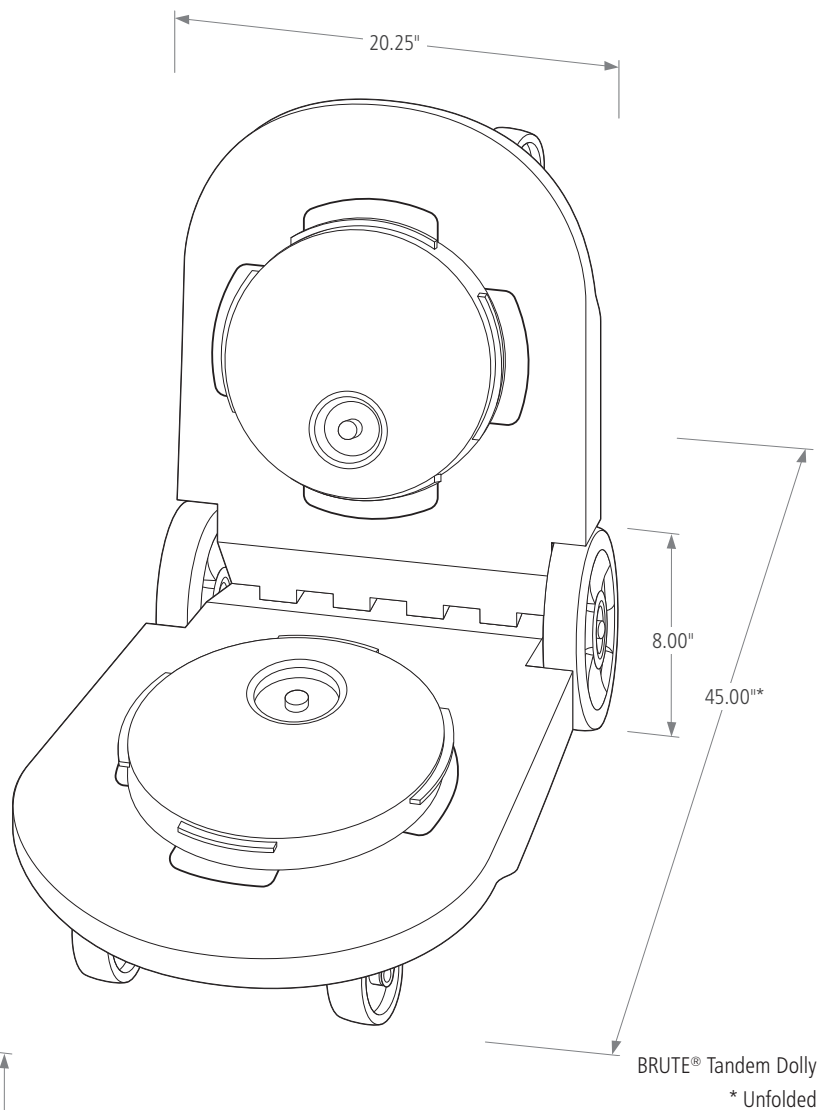

BRUTE® DOLLIES

SKU #	DESCRIPTION	COLOR	FITS	LENGTH	WIDTH	HEIGHT	DIAMETER	PACK SIZE
				IN	IN	IN	IN	
FG264000BLA	BRUTE® DOLLY	BLACK	ALL	-	-	6.63	18.25	2
FG264043BLA	BRUTE® QUIET DOLLY	BLACK	ALL	-	-	6.63	18.25	2
FG264600BLA	BRUTE® TANDEM DOLLY	BLACK	ALL	45.00	20.25	8.00	-	1





Item # _____

Job _____

SUPER ERECTA SHELF® MW UTILITY CARTS – Three-Shelf Models

- **Attractive** and thoroughly practical, these carts are offered as complete units, shipped knocked down, with all components packaged in a compact carton.
- **Super Erecta Shelf® Construction** makes units easy to assemble with absolute rigidity, and makes relocation of shelves quick and simple.
- **Choice of 26 Three-Shelf Models:** Four different shelf combinations, each in five to ten different variations.
 - MW200 Series** – Three stainless steel flat shelves. Six sizes. Stainless steel handles, except chrome handles on MW201.
 - MW300 Series** – Two stainless steel flat shelves and one chrome wire shelf. Five sizes. Chrome handles. Wire shelf can be located top, middle or bottom.
 - MW400 Series** – Two chrome wire shelves and one stainless steel flat shelf. Five sizes. Chrome handles. Solid shelf can be positioned top, middle or bottom.
 - MW700 Series** – Three wire shelves, choice of chrome or stainless steel. Five sizes; ten models. Handle material matches shelves.
- **Wire Shelves:** Bright, modern, sanitary appearance. Open construction minimizes dust accumulation, maximizes visibility and air circulation.
- **Solid Shelves:** Ideal for transporting materials that require an expanse of flat surface. Raised ship's edge permits fast clean-up in case of liquid spills. Double thickness of 18-gauge steel at edges also gives rigidity and high strength.
- **Casters:** Standard-duty. 4LD 4" (102mm) diameter casters on carts 18" (455mm) wide; 5LD 5" (127mm) diameter casters on carts 21" (530mm) and 24" (610mm) wide. See sheet #11.20 for additional information on casters.
- **Donut Bumpers**
- **One-Piece Handle**
- **Height:** 38" (965mm) floor to handle with 4" (102mm) casters; 39" (991mm) floor to handle with 5" (127mm) casters.
- **Replaceable Parts:** If any part of any cart is damaged by use, replacement parts are readily available and easily installed.
- **Accessories:** A wide variety is available to increase usefulness. See sheet #12.20.



MW700 Series



MW200 Series



MW300 Series



MW400 Series



SUPER ERECTA SHELF®
Utility Carts – Three-Shelf

MW200, MW300, MW400 and MW700 Series

12.05



InterMetro Industries Corporation
North Washington Street
Wilkes-Barre, PA 18705
www.metro.com

Copyright © 2000 InterMetro Industries Corp.

Job _____

**SUPER ERECTA SHELF®
MW UTILITY CARTS –
Three-Shelf Models**



MW Carts (Three-Shelf Models)

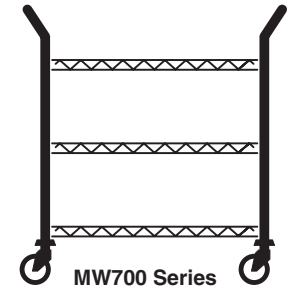
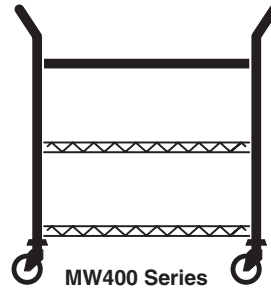
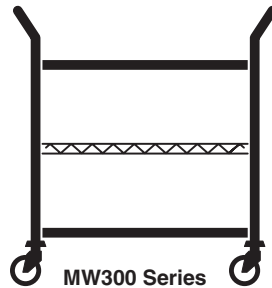

Dimensions

Cat. No.	Width		Length		Approx. Pkd. Wt.		Shelves	Shelf Material	Handles	Casters	
	(in.)	(mm)	(in.)	(mm)	(lbs.)	(kg)				(in.)	(mm)
MW203	18	455	24	610	48	21.8	3-Solid	Stainless Steel	Stainless Steel	4	102
MW204	18	455	30	760	53	24.0	3-Solid	Stainless Steel	Stainless Steel	4	102
MW205	18	455	36	910	59	26.8	3-Solid	Stainless Steel	Stainless Steel	4	102
MW206	21	530	36	910	66	29.9	3-Solid	Stainless Steel	Stainless Steel	5	127
MW208	24	610	36	910	74*	33.6	3-Solid	Stainless Steel	Stainless Steel	5	127
MW301	18	455	24	610	46	20.9	2-Solid 1-Wire	Stainless Steel Chrome	Chrome	4	102
MW302	18	455	30	760	52	23.6	2-Solid 1-Wire	Stainless Steel Chrome	Chrome	4	102
MW303	18	455	36	910	57	25.9	2-Solid 1-Wire	Stainless Steel Chrome	Chrome	4	102
MW304	21	530	36	910	62	28.1	2-Solid 1-Wire	Stainless Steel Chrome	Chrome	5	127
MW306	24	610	36	910	69	31.1	2-Solid 1-Wire	Stainless Steel Chrome	Chrome	5	127
MW401	18	455	24	610	43	19.5	1-Solid 2-Wire	Stainless Steel Chrome	Chrome	4	102
MW402	18	455	30	760	47	21.3	1-Solid 2-Wire	Stainless Steel Chrome	Chrome	4	102
MW403	18	455	36	910	52	23.6	1-Solid 2-Wire	Stainless Steel Chrome	Chrome	4	102
MW404	21	530	36	910	59	26.8	1-Solid 2-Wire	Stainless Steel Chrome	Chrome	5	127
MW406	24	610	36	910	65	29.5	1-Solid	Stainless Steel	Chrome	5	127
MW701	18	455	24	610	39	17.6	3-Wire	Chrome	Chrome	4	102
MW702	18	455	24	610	38	17.2	3-Wire	Stainless Steel	Stainless Steel	4	102
MW703	18	455	30	760	43	19.5	3-Wire	Chrome	Chrome	4	102
MW704	18	455	30	760	42	19.1	3-Wire	Stainless Steel	Stainless Steel	4	102
MW705	18	455	36	910	47	21.3	3-Wire	Chrome	Chrome	4	102
MW706	18	455	36	910	45	20.4	3-Wire	Stainless Steel	Stainless Steel	4	102
MW707	21	530	36	910	50	22.7	3-Wire	Chrome	Chrome	5	127
MW708	21	530	36	910	50	22.7	3-Wire	Stainless Steel	Stainless Steel	5	127
MW711	24	610	36	910	60	27.2	3-Wire	Chrome	Chrome	5	127
MW712	24	610	36	910	57	25.9	3-Wire	Stainless Steel	Stainless Steel	5	127

* Cannot be shipped UPS.
For utility cart accessories, refer to sections 10.05 and 10.06.

Manufactured by:



InterMetro Industries Corporation
North Washington Street, Wilkes-Barre, PA 18705
Phone: 570-825-2741 • Fax: 570-825-2852
For Product Information Call: 1-800-433-2232
Visit Our Web Site: www.metro.com

L02-055
Rev. 12/00
Printed in U.S.A.

Information and specifications are subject to change without notice. Please confirm at time of order.

12.05

**SUPER ERECTA SHELF®
Utility Carts – Three-Shelf** MW200, MW300, MW400 and MW700 Series



Edlund #1 and #2 Manual Can Openers

Edlund invented these original can openers 75 years ago, and they have set the standard in foodservice ever since. Now we've improved them to meet the even tougher requirements of today's foodservice operations. With a new smoother action base design, long wearing spool and rust resistant arbor, you just can't copy our quality.



- ① Delrin plastic spool reduces friction against handle to improve wear
- ② Base design for more rigidity

- ③ Melonite arbor provides greater rust resistance to make gear changing easier

- ④ Replaceable plastic base insert provides smooth glide action and reduces wear on opener shaft

“Old Reliable” just got more dependable.



#1 with long bar
and optional cast
iron base

FEATURES:

- Rust resistant arbor
- Made in U.S.A.
- New base with plastic insert

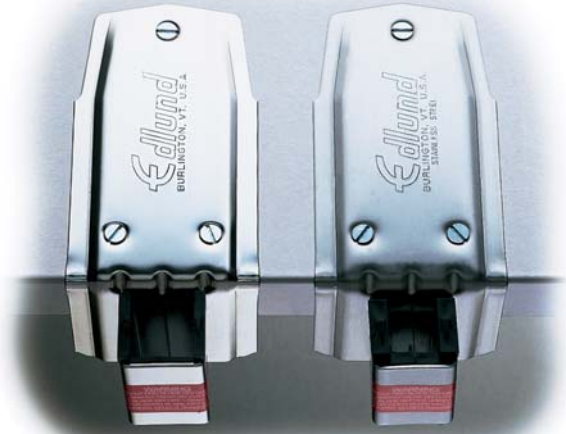

#1 and #2 models available
with plated or stainless steel bases

SPECIFICATIONS:

MODEL #	DESCRIPTION	PRODUCT CODE	CASE CUBE FT ³ /M ³	CASE WEIGHT LBS./KGS
#1	Can opener with new plated steel base (for cans up to 11" tall)	11100	1.6/.05	27/12.3
#1 S	With stainless steel base	11300	1.6/.05	28/12.6
#1 WB	Without base (Caution: Using #1 without a base may prevent proper operation)	11000	1.4/.04	22/9.9
#2	Table style can opener with new plated steel base	12100	2.6/.07	31/15.8
#2 S	With new stainless steel base	12200	2.6/.07	31/15.8
#2 WB	Without base (Caution: Using #2 without a base may prevent proper operation)	12000	2.3/.07	23/10.8
ST-93	Rustproof can opener cleaning tool	38500		.5/.2



ST-93 Rustproof
can opener cleaning tool



Edlund We're in your kitchen.™

Edlund Company, Inc., 159 Industrial Parkway, Burlington, VT 05401, USA 800-772-2126 www.edlundco.com

WARRANTY INFORMATION: THE EDLUND COMPANY WARRANTS THESE PRODUCTS TO BE FREE FROM DEFECTS IN MATERIAL AND WORKMANSHIP FOR A PERIOD OF ONE YEAR FROM DATE OF PURCHASE. THE COMPANY'S OBLIGATION UNDER THIS WARRANTY IS LIMITED TO REPAIRING OR REPLACING WITHOUT CHARGE ANY PART OR PARTS FOUND TO BE DEFECTIVE UNDER NORMAL USE. IT IS THE RESPONSIBILITY OF THE PURCHASER TO RETURN THE ENTIRE UNIT TO THE FACTORY, TRANSPORTATION CHARGES PREPAID. THIS WARRANTY DOES NOT COVER PARTS THAT MUST BE REPLACED UNDER NORMAL USE, INCLUDING KNIVES AND DRIVE GEARS ON CAN OPENERS. NO OTHER WARRANTY, WRITTEN OR VERBAL, IS AUTHORIZED BY THE COMPANY. WARRANTY INFORMATION OUTSIDE THE UNITED STATES MAY VARY, CONSULT YOUR DISTRIBUTOR. 08/08 EDL-4848

Administrative New Hire(s)

<u>Name</u>	<u>Assignment/FTE/Building</u>	<u>Effective</u>	<u>Degree/Level</u>	<u>College/University</u>	<u>Replaces/Reason</u>
No New Hires					

Administrative Transfer(s)

<u>Name</u>	<u>Former Assignment/Building</u>	<u>New Assignment/Building</u>	<u>Effective</u>	<u>Replaces/Reason</u>
No Transfers				

Administrative Resignation/Release/Retire (s)

<u>Name</u>	<u>Assignment/Building</u>	<u>FTE</u>	<u>Effective</u>	<u>Replaces/Reason</u>
No Resignation/Release/Retires				

Certificated New Hire(s)

<u>Name</u>	<u>Assignment/FTE/Building</u>	<u>Effective</u>	<u>Degree/Level</u>	<u>College/University</u>	<u>Replaces/Reason</u>
No New Hires					

Certificated Transfer(s)

<u>Name</u>	<u>Former Assignment/Building</u>	<u>New Assignment/Building</u>	<u>Effective</u>	<u>Replaces/Reason</u>
No Transfers				

Certificated Resignation/Release(s)

<u>Name</u>	<u>Assignment/Building</u>	<u>FTE</u>	<u>Effective</u>	<u>Replaces/Reason</u>
No Resignation/Release/Retires				

Extra Standard New Hire(s)

<u>Name</u>	<u>Assignment/Building</u>	<u>Level</u>	<u>FTE</u>	<u>Effective</u>	<u>Replaces/Reason</u>
Elizabeth Trausch	MS Assistant 8th Grade Track	CAT I, Lvl 1	1	8/8/2022	Tamisha Rose-Osgood

Extra Standard Transfer(s)

<u>Name</u>	<u>Former Assignment/Building</u>	<u>New Assignment/Building</u>	<u>Effective</u>	<u>Replaces/Reason</u>
No Transfers				

Extra Standard Resignation/Release(s)

<u>Name</u>	<u>Assignment/Building</u>	<u>FTE</u>	<u>Effective</u>	<u>Replaces/Reason</u>
James Westerfield	SH Assistant Boy's Soccer	1	05/20/2022	Resign

Classified New Hire(s)

<u>Name</u>	<u>Assignment/Building</u>	<u>FTE</u>	<u>Effective</u>	<u>Replaces/Reason</u>
Rebecca Gerdes	School Nurse/Districtwide	1	8/8/2022	Tabitha Fox
Arely Gomez	EL Paraeducator/Alcott	1	8/8/2022	Joselyn Estrada
Douglas Kennedy	Nigh Custodian/Middle School	1	7/10/2022	Jasmine Kennedy
Joshua Necas	Maintenance/Districtwide	1	6/10/2022	Ethan Smith

Classified Transfer(s)

<u>Name</u>	<u>Former Assignment/Building</u>	<u>New Assignment/Building</u>	<u>Effective</u>	<u>Replaces/Reason</u>
Micheal Morgan	Night Custodian/Senior High	Head Night Custodian/Senior High	6/10/2022	Shirleen Scdoris

Classified Resignation/Release(s)

<u>Name</u>	<u>Assignment/Building</u>	<u>FTE</u>	<u>Effective</u>	<u>Replaces/Reason</u>
Rachel Guiai	Paraeducator Skills 2/Middle School	1	05/19/2022	Resign
Proscovia Mills	Paraeducator-SPED/Watson	1	05/19/2022	Resign