



AGENDA

Mustang Board of Education Regular Meeting

Monday, November 11, 2024 at 6:00 PM

Mustang Educational Resource Center, 909 S. Mustang Rd., Mustang, OK
73064

As required by Section 311, Title 25 of the Oklahoma Statutes, notice is hereby given that the Board of Education of Independent School District Number I-069 of Canadian County, Oklahoma will hold Mustang Board of Education Regular Meeting on Monday, November 11, 2024 at 6:00 PM. The place and street of the meeting will be Mustang Educational Resource Center, 909 S. Mustang Rd., Mustang, OK 73064.

The Board of Education may discuss, make motions, and vote upon all matters appearing on this agenda. Such votes may be to approve, reject, table, reaffirm, rescind, or take no action on any agenda matter.

{{Name: Agenda Item Name}}

A. Invocation and Flag Salute

B. Call to Order and Roll Call (may be silent)

C. Superintendent's Report

1. Bronco Leadership Code - Students of the Month

2. 3rd Annual Native Heritage Honor Award - Katy Patterson, Coordinator of Indian Education and Bailey Murrah, Mustang High School Title VI Academic Advisor

3. All State Theatre Students - Dr. Michael Raiber, Director of Fine Arts

4. Presentation of Thanks - Dr. Karen Wilson, Executive Director of Student Services

D. Assistant Superintendent's Report

1. Academic Presentation

Stacy Edwards, Assistant Superintendent of Elementary Education

Ryan McKinney, Assistant Superintendent of Secondary Education

- Annual Student College Remediation
- Annual Dropout Report
- ACT

2.

E. Board Reports

F. Public Participation

G. Consent Agenda

1. Board of Education Minutes
 - a. October 14, 2024 Regular Board Meeting Minutes
2. Revisions of Policy and Procedures
 - a. Policy 5005 - Transfer Policy
3. Out of State or Overnight Travel
 - a. Mustang High School FFA and sponsors to attend the OSU AGR Winter Bonanza on December 6-7, 2024 at Payne County Fairgrounds, Stillwater, OK.
 - b. Jennifer Newell, Director of School Safety and Security, to attend the 2025 National Association of School Resource Officers (NASRO) conference on July 6-11, 2025 in Grapevine, TX.
 - c. Misty Eidson, Director of Elementary Curriculum, to attend the OpenSciEd Elementary Facilitator Training on December 9-12, 2024 in Chicago, IL.
 - d. Mustang High School JROTC to attend the Cowtown Classic Invitational JROTC Drill Meet on November 2, 2024 in Fort Worth, TX.
 - e. Mustang High School Girls Basketball Team and coaches to participate in the Bishop Kelley High School basketball tournament on December 5-7, 2024 in Tulsa, OK.
 - f. Mustang High School Boys Basketball Team and coaches to participate in the Bishop Kelley High School basketball tournament on December 5-7, 2004 in Tulsa, OK.
 - g. Mustang High School Wrestling team and coaches to attend the Gardner Edgerton Wrestling Tournament on December 6-8, 2024 in Gardner, KS.
 - h. Lacy Darity and Erin Workman to attend the 2024 National Fastpitch Coaches Association National Convention on December 4-7, 2024 in Dallas, TX.

- i. Katy Korstjens, Cody Little, Jared Homer and Angelica Hull to attend the Mingacon Conference on November 19-21, 2024 in Corona, CA.
 - j. Mustang High School Varsity and Junior Varsity Pom Teams to attend the Dance Team Union Regional Dance Competition on November 22-23, 2024 at Broken Arrow High School.
 - k. Mustang High School Varsity and Junior Varsity Pom Teams to attend the OSDTDA Dance Competition on December 13-15, 2024 at the Cox Convention Center in Tulsa, OK.
4. Renewal and Ratification of Agreements/Contracts
- a. Student Services
 - 1. Board of Regents University of Oklahoma
 - 2. Strategic Educational Solutions, LLC
 - b. Operations
 - 1. Southwest Cleaning
5. Computer Science Textbook Adoption Committee
6. Fine Arts Textbook Adoption Committee
7. Change Orders
- a. CADE Construction - Sunset Hill Elementary (Elementary #9)
 - 1. CO #23 - Mezzanine Wall
 - 2. CO #24 - Ellsworth paving - utilize earthwork allowance
 - 3. CO #25 - Fur out for Saferoom conduit
 - b. Timberlake Construction - Mustang High School Expansion
 - 1. CO #7 - Sanitary sewer line repair
 - 2. CO #8 - Demo Contingency Return

- c. Timberlake Construction - Mustang High School Softball Hitting Facility
 - 1. CO #20 - Add S fixture to corridor 116

H. Financial Consent Agenda

- 1. Encumbrance Registers
- 2. Change Orders Registers
- 3. Treasurer's Report
- 4. General Fund Revenue Analysis
- 5. Activity Fund Purpose of Accounts

I. Business

- 1. Discussion and possible board action to elect or not elect the following as a new member to the board of directors of the Oklahoma School Investment Interlocal Cooperative (55K001):
- 2. Discussion and possible board action to approve the state contract with United Turf, an authorized vendor of AstroTurf listed in the state contract for Artificial Turf, for the infield and outfield of the Mustang High School girls' softball field for the quoted price of \$570,000.00.
- 3. Discussion and possible board action to approve Dr. Jason Pittenger as District Treasurer of Mustang Public Schools.
- 4. Administration of the Oath of Office

J. New Business

K. Executive Session: The Board of Education will consider and may vote to convene in Executive Session.

- 1. Proposed executive session to discuss the employment, hiring, appointment, promotion, demotion, disciplining, or resignation of an employee. 25 O.S. Section 307 (B)(1). As listed on Schedule A, B & C.

L. Acknowledge Return to Open Session

- M. Statement of Executive Session minutes by Board Clerk
- N. Vote to approve or not approve the Superintendent's recommendation concerning employment as listed on Schedule "A".
- O. Vote to approve or not approve the Superintendent's recommendation concerning employment as listed on Schedule "B".
- P. Vote to approve or not approve the Superintendent's recommendation concerning employment as listed on Schedule "C".

- Q. Adjournment

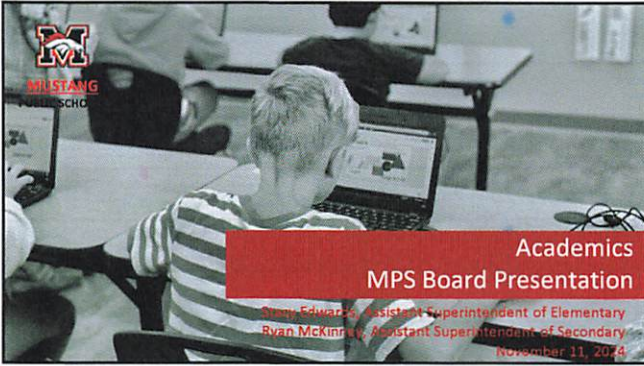

1

MPS Curriculum Team

Curriculum Team = The Resource Team



Misty Eidson | Director of Elementary Curriculum
Dr. Robbyn Glinzmann | Director of IS & MS Curriculum
Shanda Cummings | High School Curriculum & Director of Educational Technology
Dr. Lesa Rohrer | Director of High School Curriculum & Assessments
Stacy Edwards | Assistant Superintendent of Elementary Schools
Ryan McKinney | Assistant Superintendent of Secondary Schools



2

Successes



- Expansion of Mastery Connect (2nd-4th) and Implementation of ESGI (PreK-1st)
- Implementation of New Math Academic Standards and Curriculum Adoption (K-12th)
- Implementation of Updated Grading Policy (5th-12th)
- Implementation of Common Summative Assessments in (2nd-12th)
- Expansion of Instructional Coaches
- Stability in Leadership
- Strategic Professional Development Continuation
 - PLC at Work
 - Essential Standards
 - Elementary Science of Reading Training
 - LETRS Training for Cohort of Teachers (PreK-8th)
 - High Yield Instructional Strategies

3

Challenges

- Certified Teacher Shortage, Teacher Turnover, and Burnout
 - Special Education
- Substitute Shortage/Class Coverage
- Student Behaviors and Social Emotional Concerns
- Implementation of Secondary ELA Curriculum
- Chronic Absenteeism
- Multiple Sites Experience Traumatic Events During Testing Season
- Lack of Student Engagement While on Devices





4

State Testing Structure

State summative tests delivered through the Oklahoma School Testing Program (OSTP) sample from across the breadth and depth of the Oklahoma Academic Standards (OAS) to determine levels of proficiency on grade-level knowledge and skills for all students.

<p>Below Basic</p> <p>Students have not performed at least at the basic level.</p>	<p>Basic</p> <p>Students demonstrate partial mastery of the essential knowledge and skills that are foundational for proficiency work at their grade level or course and may need an track to be ready for college or career.</p>	<p>Proficient</p> <p>Students demonstrate mastery over challenging grade-level subject matter. Use critical and apply such knowledge to real-world situations. Proficient students are ready for the next grade, course, or level of education, and are on track to be ready for college or career.</p>	<p>Advanced</p> <p>Students demonstrate superior performance on challenging subject matter.</p>
---	--	--	--





5

How Do We Monitor Student Growth and Progress?

MPS Teachers and Administrators use data from a variety of assessments throughout the year to monitor student learning:

- Common Formative Assessments
- Curriculum-Based Assessments (weekly tests, unit tests, benchmark tests, etc.)
- Progress Monitoring
- Informal Assessments
- STAR Screening Assessment

6

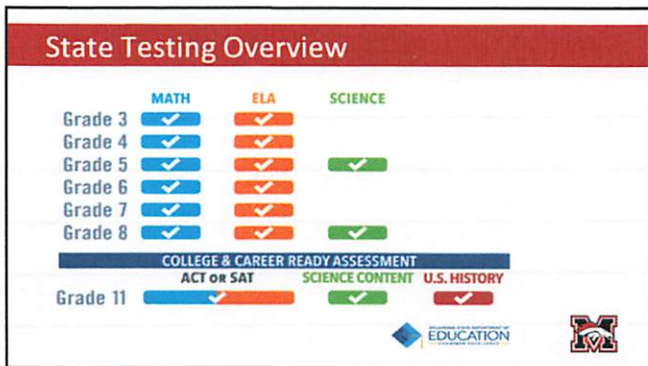

7



8

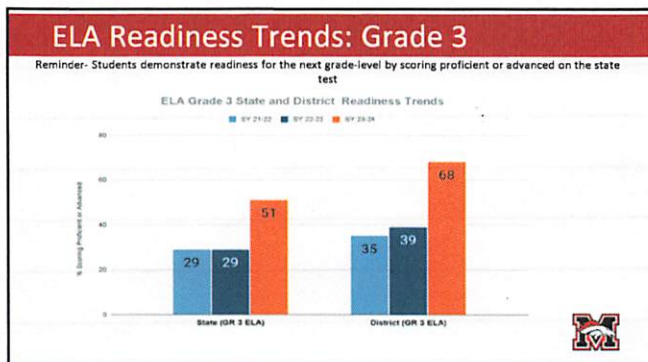

9

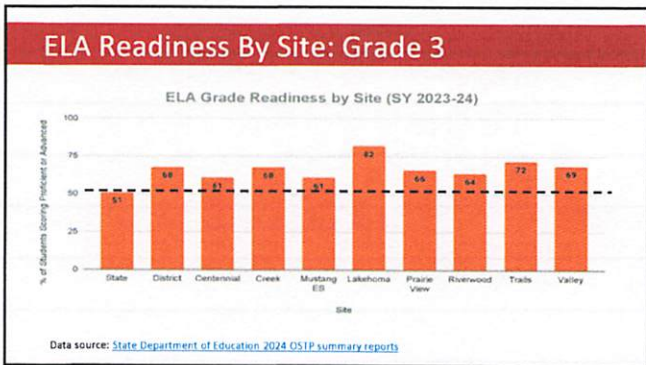

10

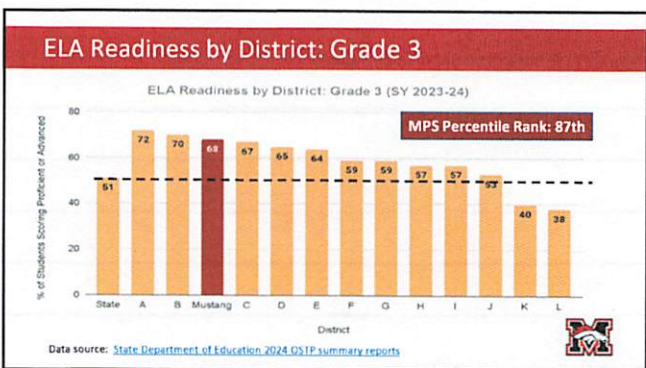

11

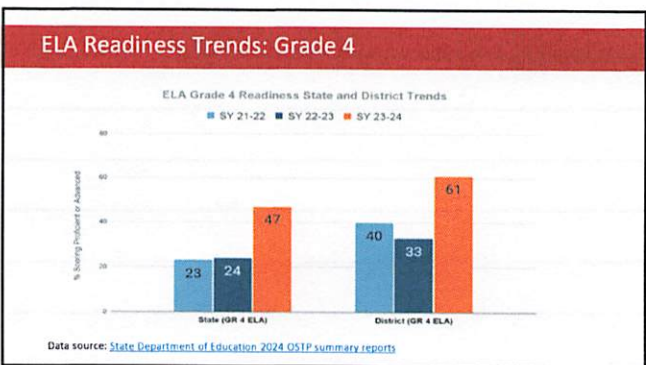

12

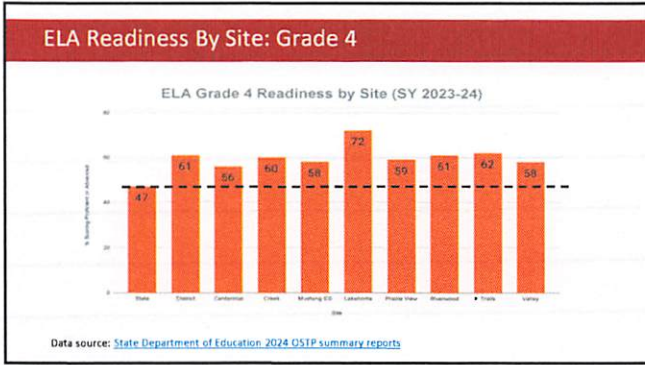

13

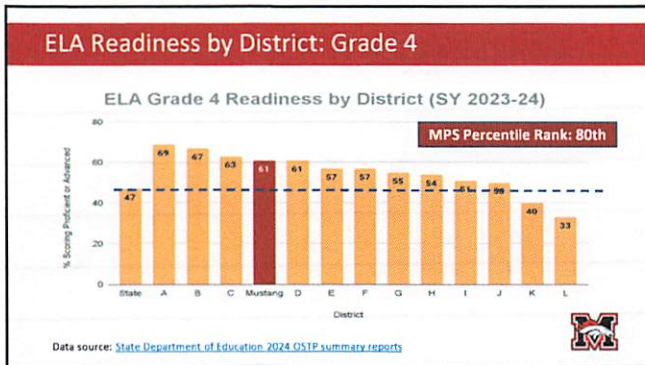

14

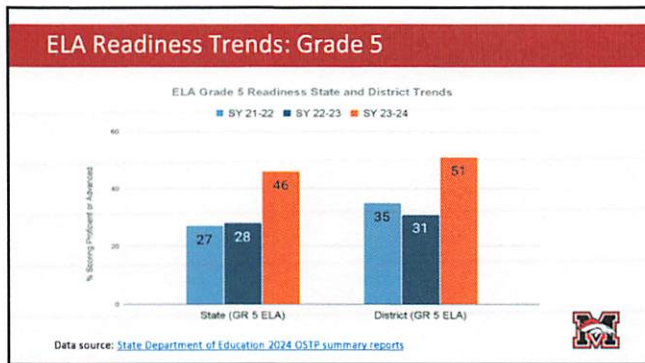

15

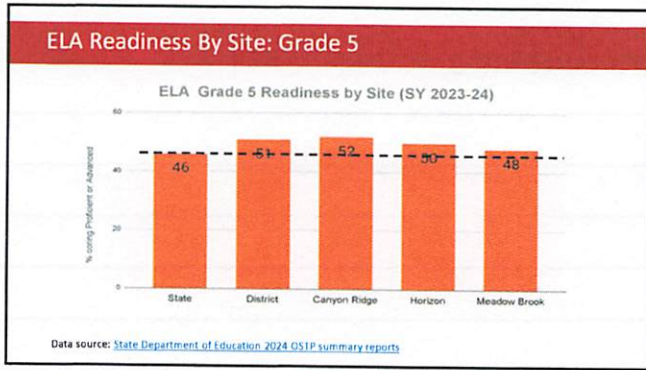

16

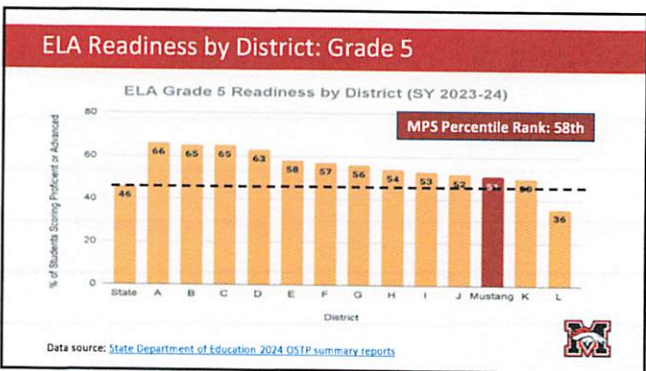

17

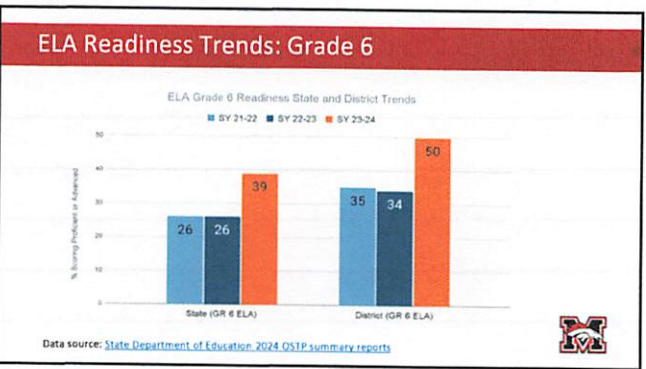

18

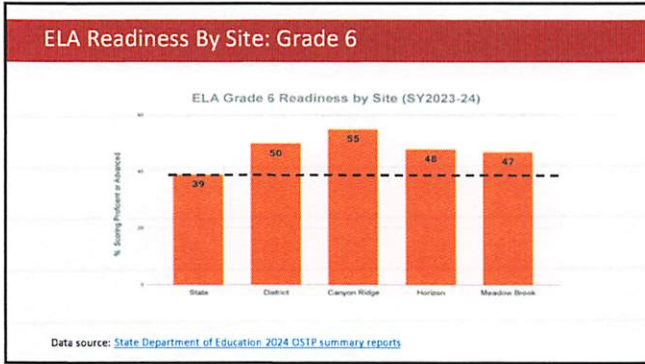

19

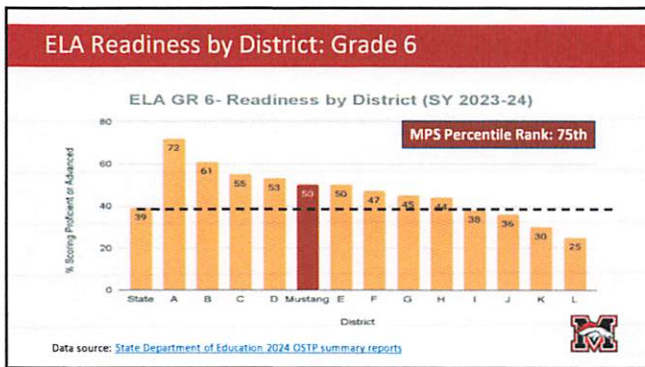

20

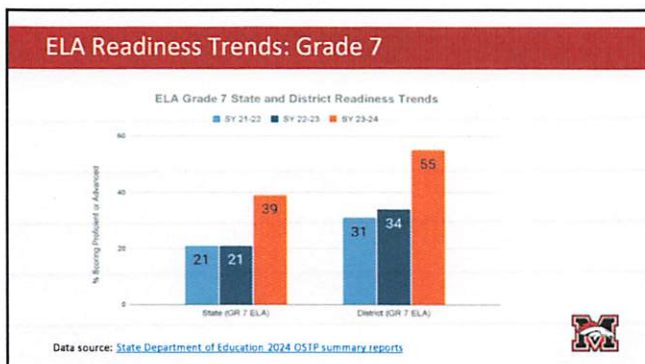

21

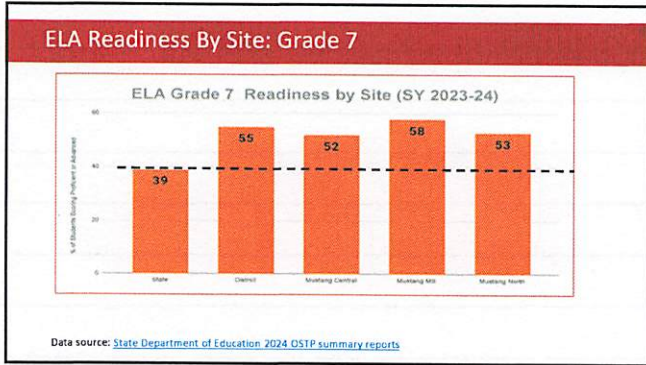

22

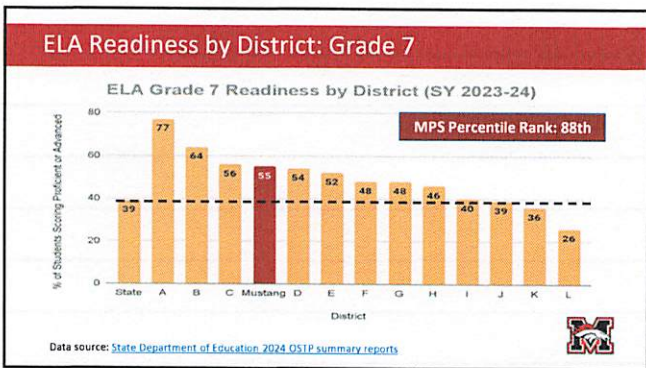

23

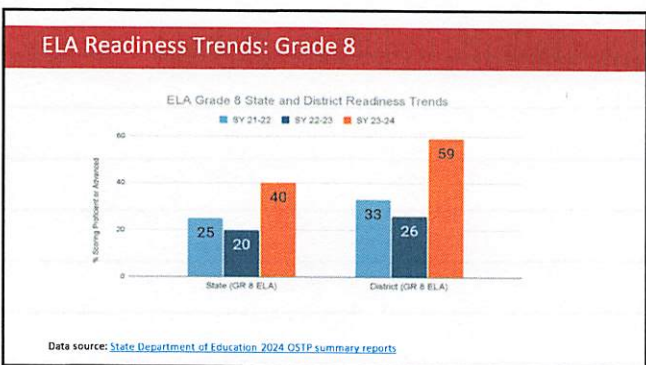

24

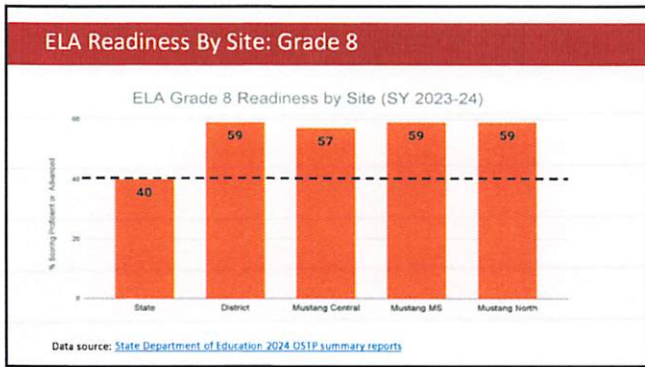

25

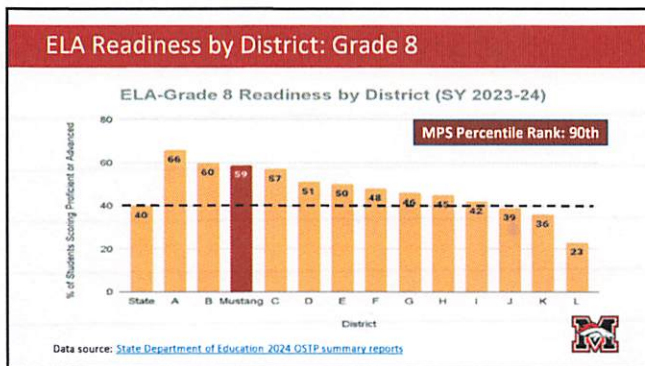

26

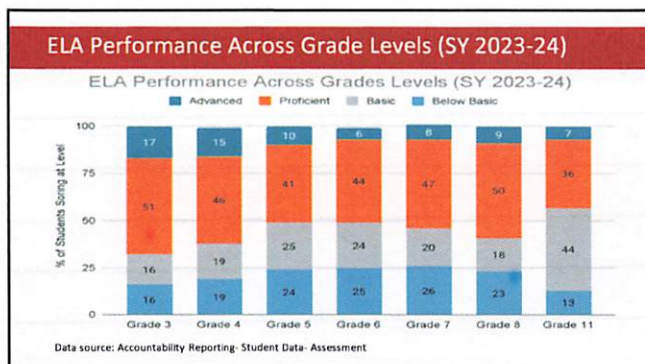

27

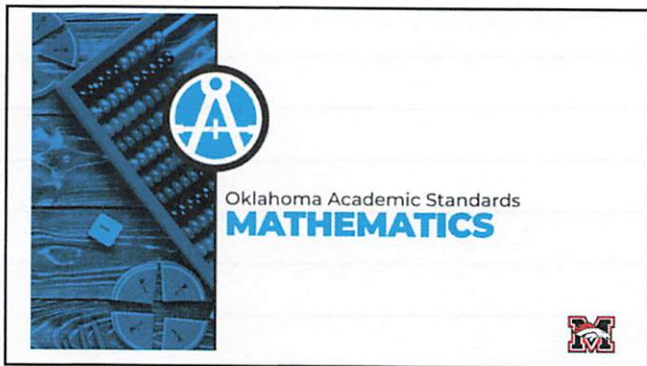

28

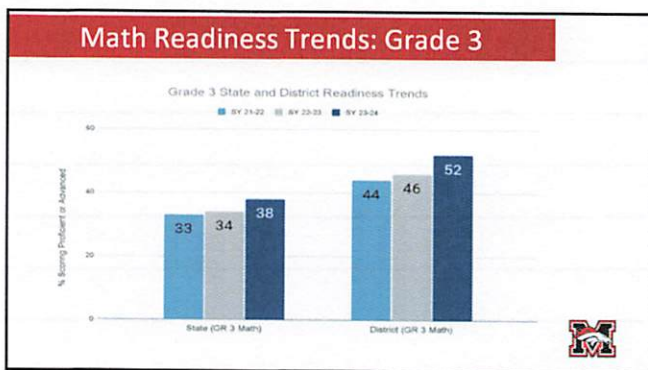

29

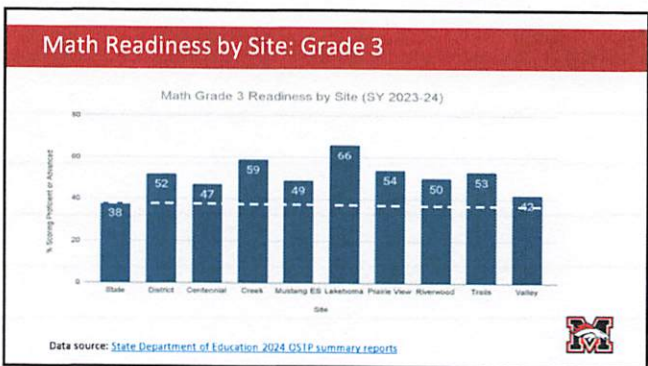

30

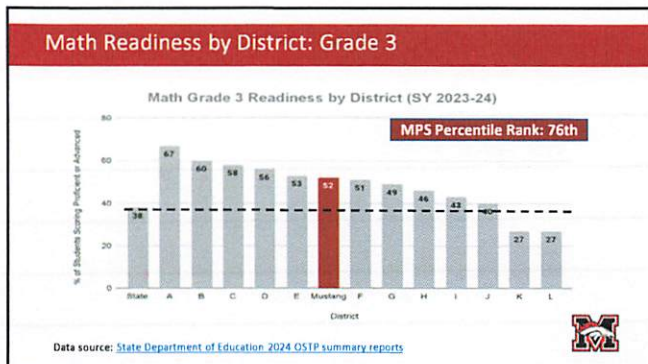

31

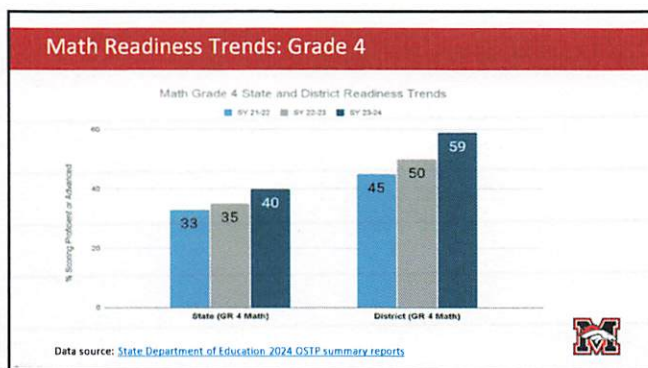

32

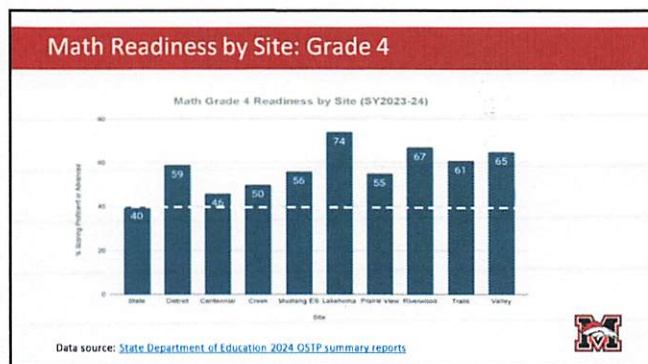

33

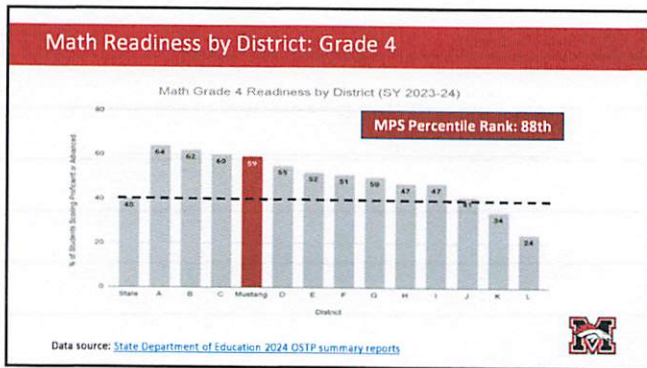

34

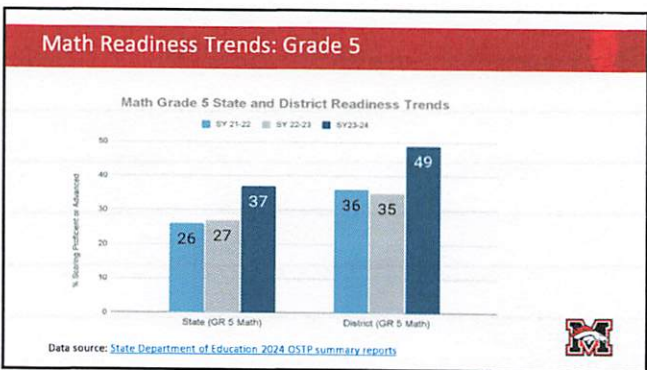

35

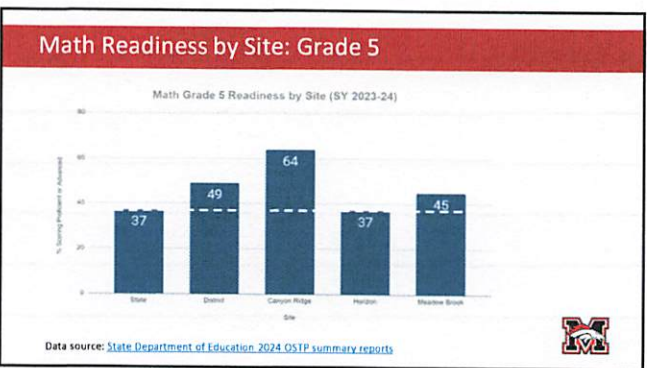

36

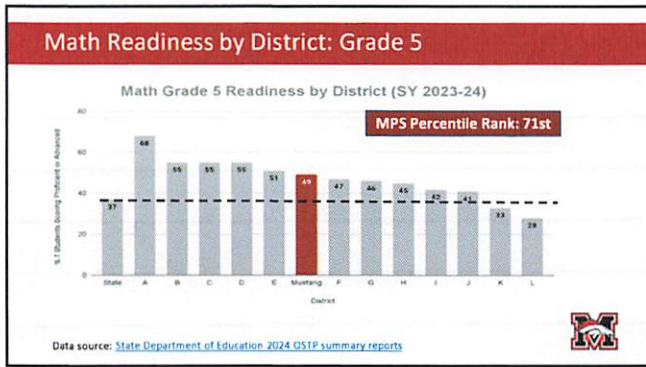

37

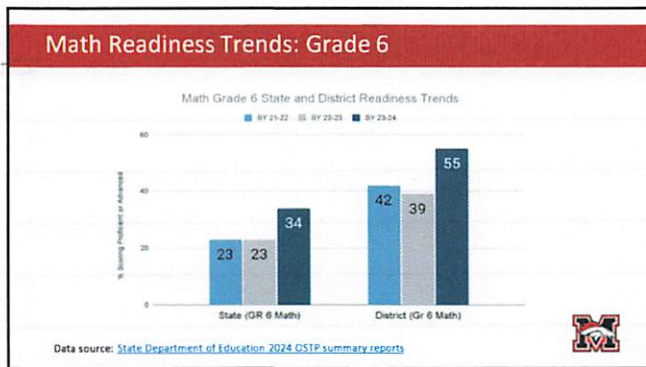

38

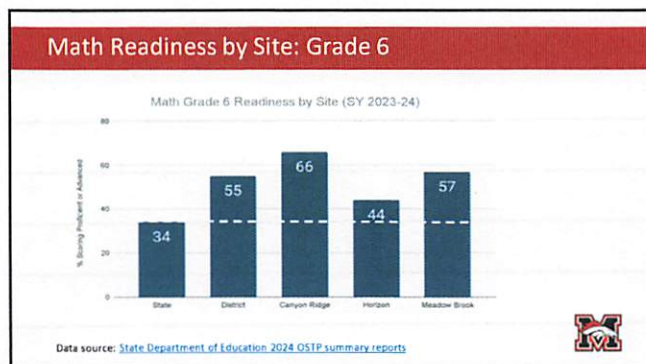

39

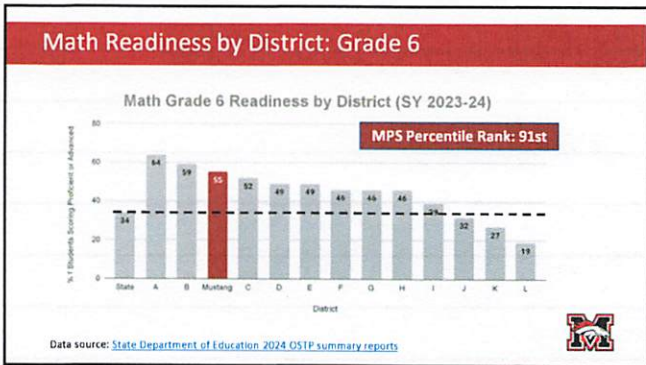

40

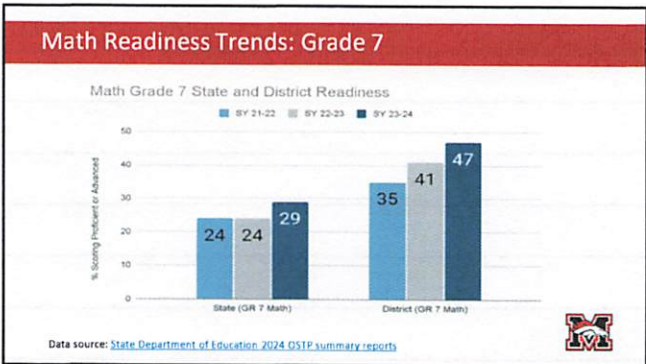

41

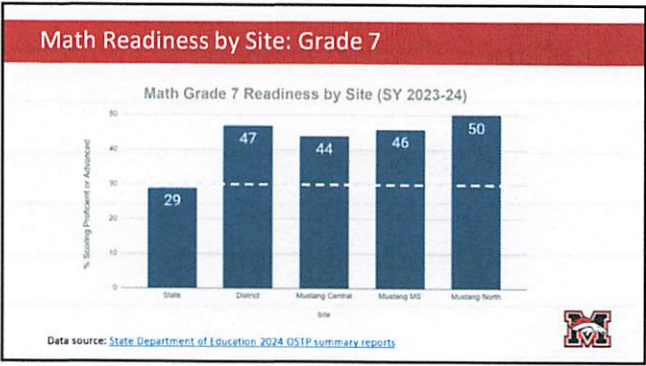

42

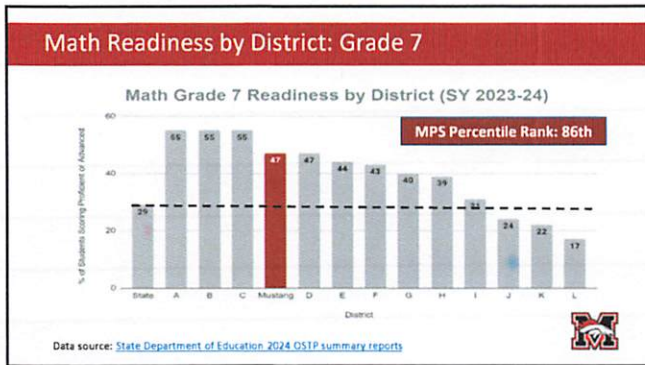

43

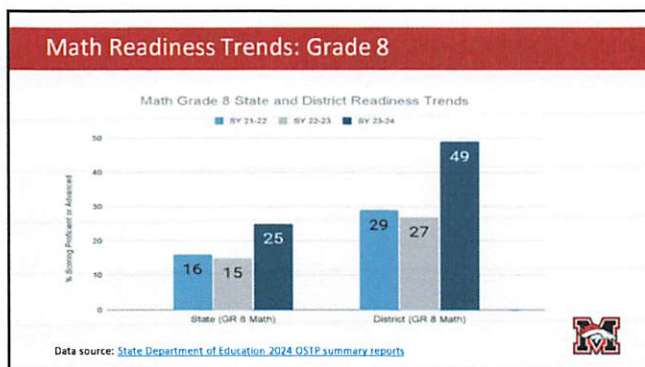

44

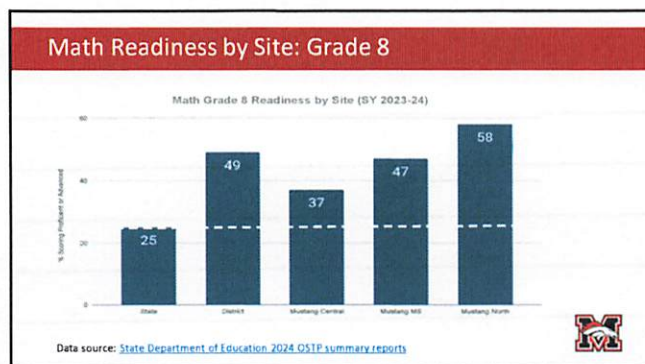

45

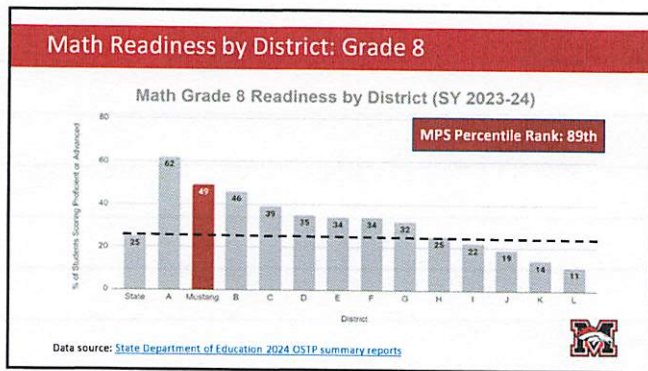

46

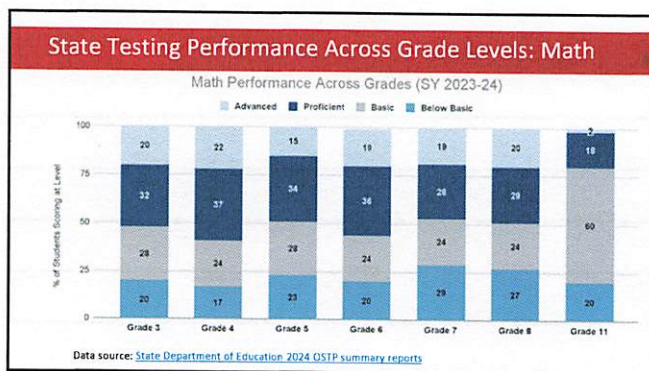

47



48

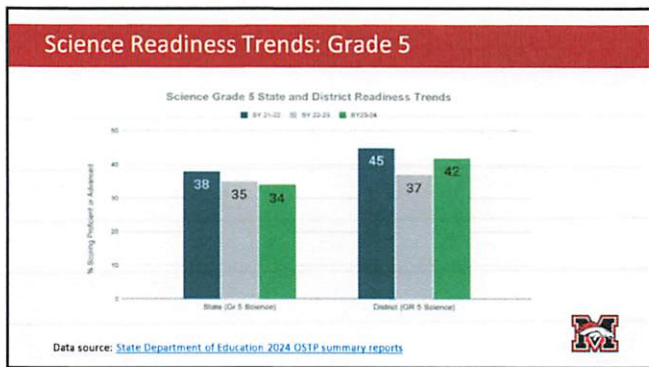

49

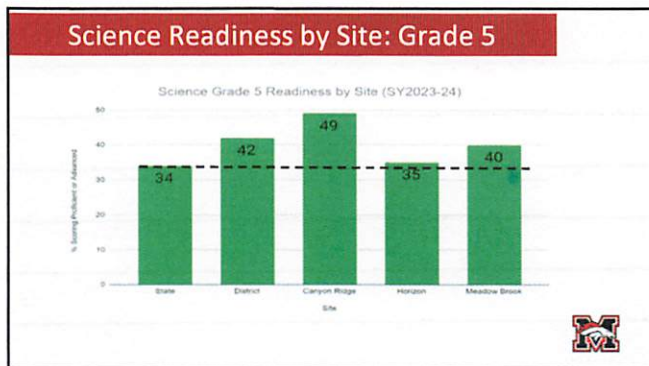

50

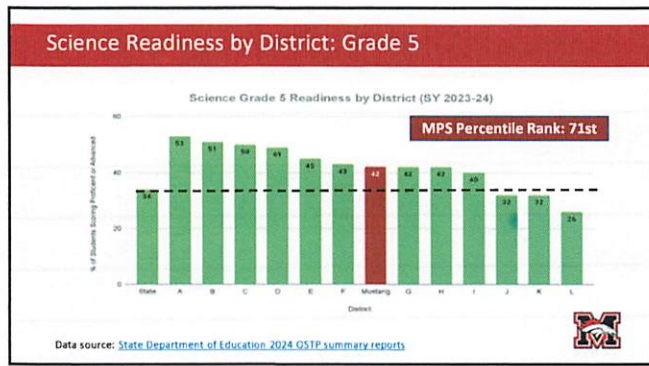

51

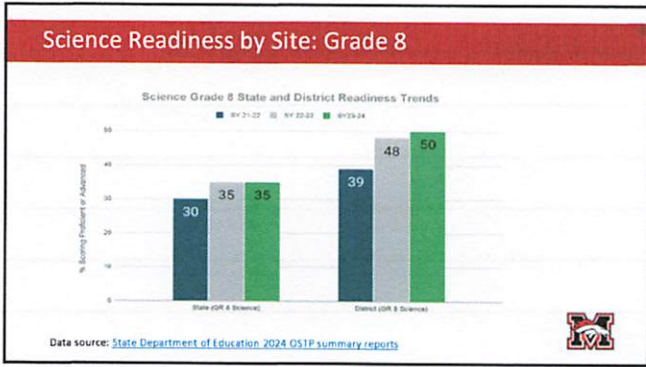

52

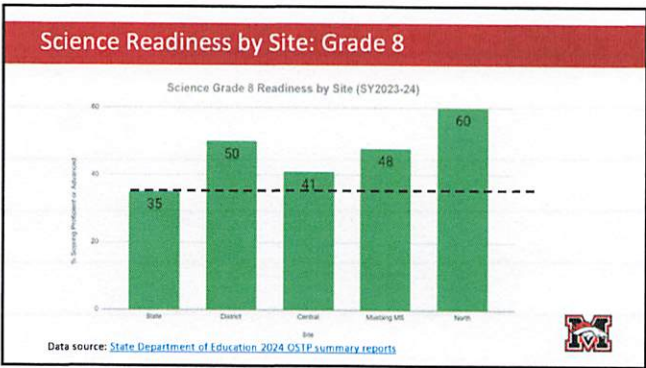

53

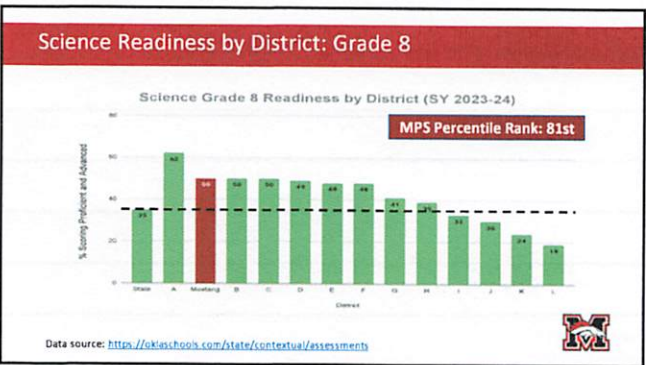

54

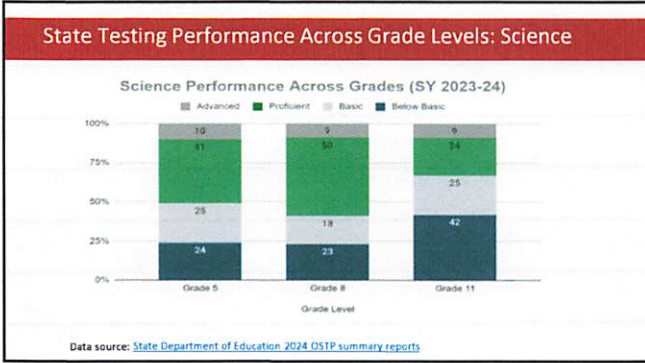

55

Takeaways

56

3rd-4th Grade Takeaways

- **3rd Grade ELA**
 - 23-24: Outperformed the state by 17% in 3rd Grade ELA
 - 22-23: Outperformed the state by 10% in 3rd Grade ELA
- **3rd Grade Math**
 - 23-24: Outperformed the state by 14% in 3rd Grade ELA
 - 22-23: Outperformed the state by 12% in 3rd Grade ELA
- **4th Grade ELA**
 - 23-24: Outperformed the state by 14% in 4th Grade ELA
 - 22-23: Outperformed the state by 9% in 4th Grade ELA
- **4th Grade Math**
 - 23-24: Outperformed the state by 19% in 4th Grade Math
 - 22-23: Outperformed the state by 15% in 4th Grade Math

57

3rd-4th Grade Next Steps

- Implemented in 2023-2024:
 - ESGI Assessment Platform in PreK-1st Grade
 - Mastery Connect Assessment Platform in 2nd-4th Grades
 - District Benchmarks in ELA and Math over Essential Standards
- UFLI
 - K-2nd - Tier 1 Instruction
 - 3rd-4th - Interventions
- Big Ideas Adoption
 - Math Curriculum Aligned to 2022 Math Standards



58

5th-8th Grade Takeaways

- **5th Grade ELA**
 - 23-24: Outperformed the state by 5% in 5th Grade ELA
 - 22-23: Outperformed the state by 3% in 5th Grade ELA
- **5th Grade Math**
 - 23-24: Outperformed the state by 12% in 5th Grade ELA
 - 22-23: Outperformed the state by 8% in 5th Grade ELA
- **6th Grade ELA**
 - 23-24: Outperformed the state by 11% in 6th Grade ELA
 - 22-23: Outperformed the state by 8% in 6th Grade ELA
- **6th Grade Math**
 - 23-24: Outperformed the state by 21% in 6th Grade Math
 - 22-23: Outperformed the state by 16% in 6th Grade Math



59

5th-8th Grade Takeaways

- **7th Grade ELA**
 - 23-24: Outperformed the state by 16% in 7th Grade ELA
 - 22-23: Outperformed the state by 13% in 7th Grade ELA
- **7th Grade Math**
 - 23-24: Outperformed the state by 18% in 7th Grade ELA
 - 22-23: Outperformed the state by 17% in 7th Grade ELA
- **8th Grade ELA**
 - 23-24: Outperformed the state by 19% in 8th Grade ELA
 - 22-23: Outperformed the state by 6% in 8th Grade ELA
- **8th Grade Math**
 - 23-24: Outperformed the state by 24% in 8th Grade Math
 - 22-23: Outperformed the state by 12% in 8th Grade Math



60

5th-8th Grade Next Steps

- New ELA Curriculum for Middle School ELA classes
- Implementation of new Math State Standards
- Increase in data literacy instruction to target crosscutting concepts in Science Standards
- Rigorous district benchmarks aligned to essential standards implemented in all core classes and data analyzed by each team and across the district
- Middle School collaborative PLCs monthly
- Vertical planning across grade levels multiple times



61

CCRA / ACT data

**ACT
Testing Data
Trends**



62

ACT Cohort Progress

759 Broncos took the PreACT as sophomores and the ACT as Juniors. Overall, 59% of these students increased their scores and the greatest gains were made in English where 71% of the students showed improvement.

- Important to note that the PreAct is a paper test and there is one less passage.

When they tested	Avg Composite Score	Avg Math Score	Avg English Score	Avg Reading Score
Grade 10 (Fall SY 22-23)	17.4	17.1	15.7	19.3
Grade 11 (Spring SY 23-24)	18.5	17.8	18.3	18.6



63

College Ready Benchmarks

Four Year Trends - Percent of Juniors Who Met College Readiness Benchmarks (CRB)

Year	Number of Students Tested		Percent of Students Who Met College Ready Benchmarks											
			English (CRB = 18)		Mathematics (CRB = 22)		Reading (CRB = 22)		Science (CRB = 23)		Met All Four		STEM (CRB = 26)	
			District	State	District	State	District	State	District	State	District	State	District	State
2022	896	38459	50	41	19	16	36	30	22	18	13	10	7	5
2023	932	45311	46	40	18	15	33	27	21	16	13	9	7	5
2024	926	50686	49	39	16	14	29	26	19	16	10	9	5	5

Data downloaded from the [ACT Reporting Portal](#) College Ready Benchmark Cuts



64

Average ACT Scores by Domain

Four Year Trends - Average ACT Scores for Juniors who took the ACT on the state testing day

Year	Number of Students Tested		Average ACT Scores											
			Composite		English		Reading		Mathematics		Science			
			District	State	District	State	District	State	District	State	District	State		
2022	896	38459	18.3	17.7	17.9	16.9	19.0	18.3	17.6	17.0	18.4	18.0		
2023	932	45311	18.4	17.5	17.6	16.7	18.6	18.0	18.0	16.9	18.8	17.8		
2024	926	50686	18.1	17.3	17.8	16.5	18.2	17.8	17.6	16.8	18.4	17.8		

Data downloaded from the [ACT Reporting Portal](#)



65

Average ACT Scores by District

District	# Tested	Composite	Math	Science	STEM	English	Reading	Writing	ELA
State	48593	17.3	16.8	17.8	17.5	16.5	17.8	5.8	16.6
A	1840	20.7	19.6	20.9	20.5	20.4	21.4	6.8	20.2
B	547	20.6	19.6	20.6	20.4	19.9	21.7	6.7	19.9
C	2047	19.5	18.8	19.9	19.6	18.8	19.9	6	17.8
D	609	19	18.2	19.1	18.9	18.4	19.6	6.1	17.4
E	453	18.9	18.2	19.4	19.1	18.1	19.4	6.5	18.4
F	1132	18.7	17.9	18.8	18.6	17.9	19.5	6.5	18.5
G	714	18.2	17.4	18.5	18.5	17.8	18.7	6	17.6
City	894	18.1	17.6	18.4	18.2	17.8	18.2	6.1	17.6
H	1388	17.9	17.4	18.2	18.1	17.1	18.4	6.3	17.6
I	283	17.1	16.2	17.7	17.2	16.3	17.7	5.9	16.2

Data as reported by [Districts](#)

66

CCRA

College Career Readiness Assessments

State Test for Juniors
 ELA & Math = ACT
 Science = CCRA



67

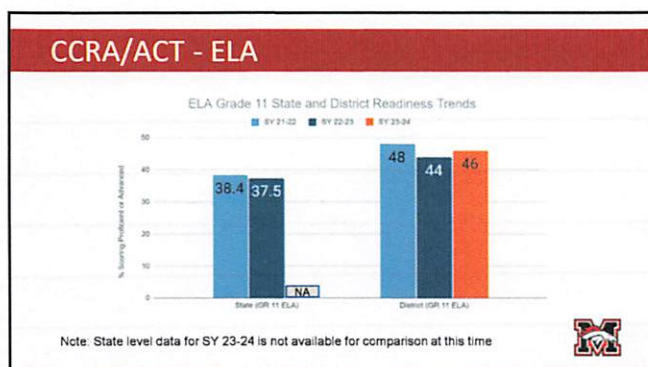

68

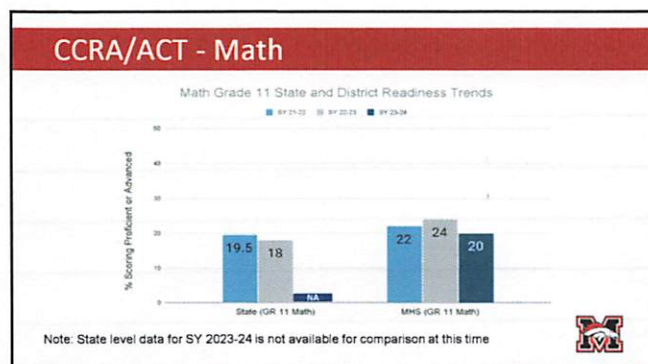

69

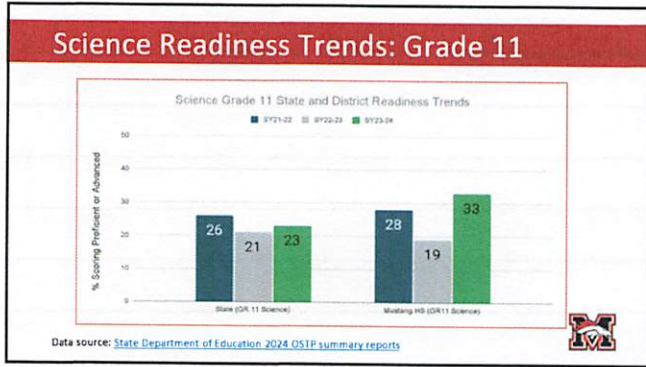

70

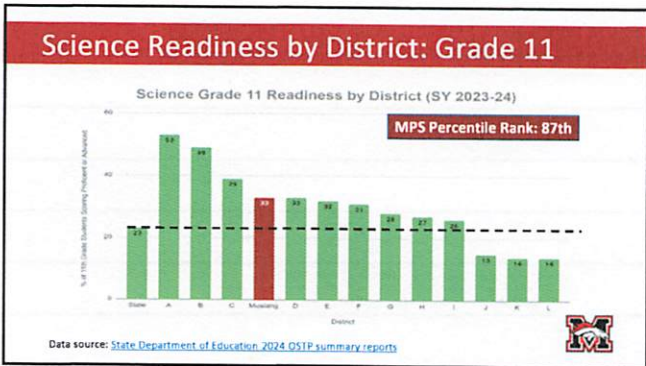

71

Post Secondary Opportunities

72

Postsecondary Opportunities

AP <small>(Advanced Placement)</small>	18-19	19-20	20-21	21-22	22-23	23-24
Number of students that took AP exam	282	251	179	236	252	343
Number of Exams	508	450	296	412	455	541
AP Students with Scores 3+	166	145	111	146	147	205
% of Total AP Students with Scores 3+	58.87	57.77	62.01	63.86	58.33	59.77

Data from [College Board AP](#)

73

Postsecondary Opportunities

Career Tech Enrollment	Fall	Spring
2020-2021	327	310
2021-2022	323	283
2022-2023	480	489
2023-2024	572	521
2024-2025	535	N/A

Represents individual students attending CT off campus through Canadian County Career Tech

74

Postsecondary Opportunities

Concurrent Enrollment	Fall	Spring
2020-2021	285	234
2021-2022	303	236
2022-2023	259	233
2023-2024	295	284
2024-2025	315	N/A

75

Dropouts & Additional Pathways



76

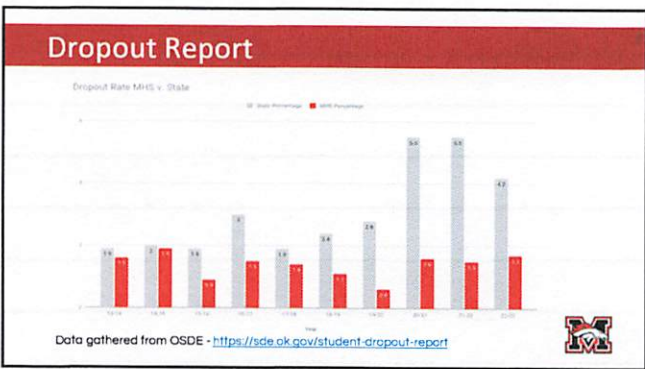

77

Alternate Pathways

Program	Description	Enrolled
Alt Ed	housed at MEC for students needing credit recovery as well as initial credit	60
Project Connect	housed at Canadian County Career Tech Center in El Reno	12
Mustang Treatment Center	housed on Highway 152 in Mustang	9
Canadian County Education Center	housed at the Juvenile Justice Center in El Reno	15



78

9th-12th Grade Takeaways

- Overall, we are above the state average in all ACT scoring areas
- The majority of students that took the PreAct as sophomores made gains on their ACT scores as juniors
- Consistent ACT scores for ELA and Math
- Significant increase in CCRA Science scores
- Increase in the number of students taking AP exams
- Drop out rate is still well below the state average
- Concurrent enrollment is on the rise



79

9th-12th Grade Next Steps

- Curriculum Directors and ICs are working closely with Team Leaders to improve PLC processes in core subjects
- District Benchmarks for SY 24-25 include targeted ACT questions aligned so that students are gaining experience
- ACT bootcamps
- Curriculum Maps developed or re-designed to focus on ACT standards and to address gaps identified by Benchmark Testing
- New Teacher Academy with twice monthly meetings/PD, mentor teachers, New Teacher binders, and intense support from ICs



80

9th-12th Grade Next Steps

- Focus on literacy throughout the year with expectations that teachers are implementing targeted strategies on a regular basis in all classrooms
- Emphasis on utilizing adopted curriculum to support instruction
- Flex Time built into the weekly bell schedule with the expectation that teachers are using it to provide reteaching, retesting, and Tier 2 intervention
- Implementation of adopted Math curriculum



81

Curriculum Team Focus and Vision



- Continue to use multiple data points to monitor student performance and growth
- Target the precise skills students are ready to learn
- Provide resources and training to support best instruction and practice
- Targeted essential standards by content area to strengthen focus
- Better meet the individual needs of all students including English Learners
- Continue to provide quality professional development experiences for our teachers



82



MUSTANG
PUBLIC SCHOOLS

Questions?

83



SY 2023-24 State Test Scores Comparison by District

Grade 3 ELA Readiness (SY 2023-24)			Grade 4- ELA Readiness (SY 2023-24)		
District		% Pro + Adv	District		% Pro + Adv
State		51	State		47
Deer Creek	A	72	Deer Creek	A	69
Piedmont	B	70	Piedmont	B	67
Mustang		68	Stillwater	C	63
Owasso	C	67	Mustang		61
Edmond	D	65	Edmond	D	61
Moore	E	64	Owasso	E	57
Yukon	F	59	Moore	F	57
Jenks	G	59	Jenks	G	55
Stillwater	H	57	Norman	H	54
Norman	I	57	Yukon	I	51
Broken Arrow	J	53	Broken Arrow	J	50
Shawnee	K	40	Shawnee	K	40
Putnam City	L	38	Putnam City	L	33



SY 2023-24 State Test Scores Comparison by District

Grade 5- ELA Readiness (SY 2023-24)			Grade 6 ELA Readiness (SY 2023-24)		
District		% Prof + Adv	District		% Prof + Adv
State		46	State		39
Stillwater	A	66	Piedmont	A	72
Piedmont	B	65	Deer Creek	B	61
Deer Creek	C	65	Moore	C	55
Edmond	D	63	Edmond	D	53
Owasso	E	58	Mustang		50
Jenks	F	57	Stillwater	E	50
Moore	G	56	Jenks	F	47
Yukon	H	54	Yukon	G	45
Broken Arrow	I	53	Owasso	H	44
Norman	J	52	Norman	I	38
Mustang		51	Broken Arrow	J	36
Shawnee	K	50	Shawnee	K	30
Putnam City	L	36	Putnam City	L	25



SY 2023-24 State Test Scores Comparison by District

Grade 7- ELA Readiness (SY 2023-24)			Grade 8 ELA Readiness (SY 2023-24)		
District		% Prof + Adv	District		% Prof + Adv
State		39	State		40
Piedmont	A	77	Deer Creek	A	66
Deer Creek	B	64	Piedmont	B	60
Stillwater	C	56	Mustang		59
Mustang		55	Stillwater	C	57
Edmond	D	54	Edmond	D	51
Yukon	E	52	Yukon	E	50
Jenks	F	48	Jenks	F	48
Moore	G	48	Owasso	G	46
Owasso	H	46	Moore	H	45
Norman	I	40	Norman	I	42
Shawnee	J	39	Broken Arrow	J	39
Broken Arrow	K	36	Shawnee	K	36
Putnam City	L	26	Putnam City	L	23



SY 2023-24 State Test Scores Comparison by District

Grade 3 Math Readiness (SY 2023-24)			Grade 4- Math Readiness (SY 2023-24)		
District		% Pro + Adv	District		% Pro + Adv
State		38	State		40
Piedmont	A	67	Deer Creek	A	64
Deer Creek	B	60	Piedmont	B	62
Owasso	C	58	Stillwater	C	60
Stillwater	D	56	Mustang		59
Edmond	E	53	Edmond	D	55
Mustang		52	Owasso	E	52
Yukon	F	51	Yukon	F	51
Moore	G	49	Moore	G	50
Norman	H	46	Jenks	H	47
Jenks	I	43	Norman	I	47
Broken Arrow	J	40	Broken Arrow	J	41
Shawnee	K	27	Shawnee	K	34
Putnam City	L	27	Putnam City	L	24



SY 2023-24 State Test Scores Comparison by District

Grade 5 Math Readiness (SY 2023-24)			Grade 6- Math Readiness (SY 2023-24)		
District		% Pro + Adv	District		% Pro + Adv
State		37	State		34
Stillwater	A	68	Deer Creek	A	64
Yukon	B	55	Piedmont	B	59
Deer Creek	C	55	Mustang		55
Edmond	D	55	Owasso	C	52
Owasso	E	51	Stillwater	D	49
Mustang		49	Moore	E	49
Piedmont	F	47	Yukon	F	46
Moore	G	46	Edmond	G	46
Jenks	H	45	Jenks	H	46
Norman	I	42	Norman	I	39
Broken Arrow	J	41	Broken Arrow	J	32
Shawnee	K	33	Shawnee	K	27
Putnam City	L	28	Putnam City	L	19



SY 2023-24 State Test Scores Comparison by District

Grade 7 Math Readiness (SY 2023-24)			Grade 8 Math Readiness (SY 2023-24)		
District		% Pro + Adv	District		% Pro + Adv
State		29	State		25
Piedmont	A	55	Deer Creek	A	62
Deer Creek	B	55	Mustang		49
Stillwater	C	55	Stillwater	B	46
Mustang		47	Owasso	C	39
Owasso	D	47	Piedmont	D	35
Edmond	E	44	Yukon	E	34
Moore	F	43	Moore	F	34
Yukon	G	40	Edmond	G	32
Jenks	H	39	Jenks	H	25
Norman	I	31	Norman	I	22
Broken Arrow	J	24	Broken Arrow	J	19
Shawnee	K	22	Putnam City	K	14
Putnam City	L	17	Shawnee	L	11



SY 2023-24 State Test Scores Comparison by District

Grade 5- Science Readiness (SY 2023-24)			Grade 8 Science Readiness (SY 2023-24)		
District		% Prof + Adv	District		% Prof + Adv
State		46	State		35
Stillwater	A	66	Deer Creek	A	62
Piedmont	B	65	Mustang		50
Deer Creek	C	65	Owasso	B	50
Edmond	D	63	Stillwater	C	50
Owasso	E	58	Edmond	D	49
Jenks	F	57	Piedmont	E	48
Moore	G	56	Jenks	F	48
Yukon	H	54	Yukon	G	41
Broken Arrow	I	53	Moore	H	39
Norman	J	52	Norman	I	33
Mustang		51	Broken Arrow	J	30
Shawnee	K	50	Putnam City	K	24
Putnam City	L	36	Shawnee	L	19



SY 2023-24 State Test Scores Comparison by District

Grade 11- Science Readiness (SY 2023-24)		
District		% Prof + Adv
State		23
Deer Creek	A	53
Edmond	B	49
Stillwater	C	39
Mustang		33
Norman	D	33
Owasso	E	32
Moore	F	31
Piedmont	G	28
Jenks	H	27
Yukon	I	26
Putnam City	J	15
Shawnee	K	14
Broken Arrow	L	14

Data source [State Department of Education 2024 OSTP summary reports](#)



SY 2023-24 State Test Scores Comparison by District

Average ACT Scores by District (SY 2023-24)					
District		# tested	Composite	Math	Science
State		48593	17.3	16.8	17.8
Edmond	A	1840	20.7	19.6	20.9
Deer Creek	B	547	20.6	19.6	20.6
Moore	C	2047	19.5	18.8	19.9
Choctaw	D	609	19	18.2	19.1
Stillwater	E	453	18.9	18.2	19.4
Norman	F	1132	18.7	17.9	18.8
Yukon	G	714	18.2	17.4	18.5
Mustang		894	18.1	17.6	18.4
Broken Arrow	H	1388	17.9	17.4	18.2
18.2Guthrie	I	283	17.1	16.2	17.7

Average ACT Scores by District (SY 2023-24)						
District		STEM	English	Reading	Writing	ELA
State		17.5	16.5	17.8	5.8	16.6
Edmond	A	20.5	20.4	21.4	6.8	20.2
Deer Creek	B	20.4	19.9	21.7	6.7	19.9
Moore	C	19.6	18.8	19.9	6	17.8
Choctaw	D	18.9	18.4	19.6	6.1	17.4
Stillwater	E	19.1	18.1	19.4	6.5	18.4
Norman	F	18.6	17.9	19.5	6.5	18.5
Yukon	G	18.5	17.8	18.7	6	17.6
Mustang		18.2	17.8	18.2	6.1	17.6
Broken Arrow	H	18.1	17.1	18.4	6.3	17.6
Guthrie	I	17.2	16.3	17.7	5.9	16.2

Data was self-reported by District DTC



Mustang Board of Education Regular Meeting
 Draft Minutes
 Monday, October 14, 2024 6:00 PM
 Mustang Educational Resource Center, 909 South Mustang Rd., Mustang, OK 73064

AUTHORITY OF THE BOARD OF EDUCATION

As required by Section 311, Title 25 of the Oklahoma Statutes, notice is hereby given that the Board of Education of Independent School District Number I-069 of Canadian County, Oklahoma held Mustang Board of Education Regular Meeting on Monday, October 14, 2024 at 6:00 PM. The place and street of the meeting was Mustang Educational Resource Center, 909 South Mustang Rd., Mustang, OK 73064.

Notice of this meeting was given to the County Clerk of Canadian County, Oklahoma at least forty-eight (48) hours prior to such meeting, and public notice of this meeting, with an agenda posted in prominent view at the Mustang Educational Resource Center 909 South Mustang Rd., Mustang, OK at least twenty-four (24) hours prior to this meeting, excluding Saturdays, Sundays and legal holidays, all in compliance with the Oklahoma Open Meeting Act.

A. Invocation and Flag Salute

Invocation and Flag Salute - Todd Lovelace

B. Call to Order and Roll Call (may be silent)

Dr. Rader, Board President, called the meeting to order at 6:00 PM. Those present were Dr. Rader, Todd Lovelace, Travis Helling, Toby Thompson and Sarah Lippencott.

C. Superintendent's Report

1. Bronco Leadership Code - Students of the Month

Centennial Elementary	Claire Burks	Canyon Ridge Intermediate	Phoebe David
Creek Elementary	Trinity McMillan	Canyon Ridge Intermediate	Jacklyn Matthews
Lakehoma Elementary	Layton Black	Horizon Intermediate	Oakly Hill
Mustang Elementary	Hector Ramos	Meadow Brook Intermediate	Maren VanVoast
Prairie View Elementary	Gunner Cummins	Mustang Central Middle School	Camilla Rosales
Riverwood Elementary	Lucca Chicaroni	Mustang North Middle School	Mia Greiner
Trails Elementary	Korin Sanderson	Mustang Middle School	Tripp Daniels
Valley Elementary	Seth Hastings	Mustang Education Center	Electra Gillispie
		Mustang High School	Mariela Robertson

2. Jason Doran

D. Assistant Superintendent's Report

1. Stacy Edwards, Assistant Superintendent of Elementary Education
Elementary #9 Update
2. Stacy Edwards, Assistant Superintendent of Elementary Education
Ryan McKinney, Assistant Superintendent of Secondary Education
Annual Student College Remediation
Report Annual Dropout Report
ACT
Academic Update

The Assistant Superintendent's Report was tabled for a later date.

3. Geromy Schrick, Executive Director of Technology
Ryan McKinney, Assistant Superintendent of Secondary Education
Classwize

E. Board Reports

No Board Reports

F. Public Participation

The floor shall be open to the public, and any regular meeting shall include an opportunity for the public to address the Board other than personnel matters. Presentations under Public Participation are limited to five (5) minutes and where several people wish to address the same subject, a spokesperson must be selected. Those residents wishing to address the Board of Education must complete a Request for Public Participation form prior to the scheduled starting time of the regular Board meeting. A response may not be provided at this time. Questions or concerns related to employees of the district will not be permitted at this time. Those are to be referred to the Superintendent at another time.

No Public Participation

G. Consent Agenda

All the following items, which concern reports and items of a routine nature normally approved at board meetings, will be approved by one vote, unless any board member desires to have a separate vote on any or all of these items. The consent agenda consists of discussion, consideration and action on the following items that the Superintendent recommends be approved.

Motion to approve consent agenda items G1-G11. This motion, made by Todd Lovelace and seconded by Travis Helling, Passed.

Travis Helling: Aye, Sarah Lippencott: Aye, Todd Lovelace: Aye, Dr. Robert Rader: Aye, Toby Thompson: Aye

Motion to approve items H1-3. This motion, made by Todd Lovelace and seconded by Travis Helling, Passed.

Travis Helling: Aye, Sarah Lippencott: Aye, Todd Lovelace: Aye, Dr. Robert Rader: Aye, Toby Thompson: Aye

1. Board of Education Minutes
 - a. September 9, 2024 Regular Board Meeting Minutes
2. Use of Facilities

- a. Meadowbrook Intermediate - Gym
 - 1. Space Jam Basketball
 - b. Valley Elementary - Cafeteria
 - 1. Brookstone Lakes West HOA
 - 2. Wimberley Estates III HOA
 - c. Mustang Central Middle School - Gym and Cafeteria
 - 1. Oklahoma City Gymnastics
 - d. Performing Arts Center (PAC)
 - 1. OKC Ballet Fall Performance
 - 2. Lone Star Dance Masters Regional Competition
 - 3. Triumph National Talent
 - 4. Ms. Oklahoma Senior America Pageant
 - 5. OKC Ballet Spring Performance
3. Out of State or Overnight Travel
- a. Dr. Michael Raiber to attend the Band of America Grand National Championships on November 14-16, 2024 in Indianapolis, IN.
 - b. Carrie Hixon to attend the Jumpstart National Educator Conference on November 2-4, 2024 in Louisville, KY.
 - c. Richelle Miller and Albany McClure to attend the Transporting Students with Disabilities Conference on November 7-12, 2024 in Frisco, TX.
 - d. Gary Knowles to attend the Aircraft Owners and Pilot Association's (AOPA's) 2024 You Can Fly High School STEM Symposium on November 17-19, 2024 in Atlanta, GA.
 - e. Gary Knowles to attend the NASA Oklahoma Space Grant Consortium, STEM in ACTION, on October 25-27, 2024 in Stillwater, OK.
 - f. Mustang High School Cross Country team and coaches attend the Nike South Regionals Cross Country Meet on November 22-24, 2024 in Woodlands, TX.
 - g. Mustang High School Boys and Girls Track and Field and coaches to attend the Razorback Invitational on January 10-12, 2025 at the University of Arkansas in Fayetteville, AR.
 - h. Mustang High School DECA members and Advisors to attend the DECA Sports and Entertainment Marketing Conference on January 29–February 2, 2025 in Orlando, FL.
 - i. The following teachers to attend the Oklahoma Fine Arts Institute Conference at Quartz Mountain in Lone Wolf, OK.
 October 3-6, 2024 - Breanne George, Art - Canyon Ridge Intermediate
 October 10-13, 2024 - Rachel Tilley, Art I - Mustang High School
 Sarah Carnes, Crafts - Mustang High School

October 17-20, 2024 - Sierra Machado, AP Art - Mustang High School
Natasha Duke, Music - Trails Elementary

4. Renewal and Ratification of Agreements/Contracts

a. Student Services

1. University of Oklahoma - Board Certified Behavioral Analysts (BCBA)
2. Motor Mouth Therapy

b. Canadian Valley Technology Center Transportation

1. Canadian Valley Technology Center, El Reno Campus
2. Canadian Valley Technology Center, Earl Cowan Campus

5. Job Description

a. Lead Nurse

b. Special Education Behavior Support Paraprofessional

6. Surplus

a. Buses

1. Bus 9 - 2005 Bluebird VIN - 1BAKCCKA45F228668
2. Bus 10 - 2005 Bluebird VIN - 1BAKGCKA45F228660
3. Bus 21 - 2006 Bluebird VIN - 1BAKGCKA36F236007
4. Bus 25 - 2006 Bluebird VIN - 1BAKGCKAX6F236005
5. Bus 26 - 2006 Bluebird VIN - 1BAKGCKA16F236006

7. Approval of the following for the annual school board election for board position #5, which has a 5-year term of office.

a. Resolution

b. Legal Notice

c. Press Release

8. Additional updates to the Bronco Club Parents Handbook.

9. Approval of the easement to OG&E for the relocation of the transformer from the Mustang High School's old gymnasium to the Wellness Center.

10. Approval of the easement for the private drainage restrictions required by Oklahoma City for the detention pond at elementary #9.

11. Approval of the easement next to Prairie View Elementary to MECO Services and ONEOK for the relocation of natural gas lines tied to the widening of the 59th Street project approved by Oklahoma City.

H. Change Orders

1. CADE Construction - Elementary #9
 - a. Change Order #20 - 266 & C. - OKC Storm Water Quality - Additional Erosion Control
 - b. Change Order #21 - Cherokee Painting - Paint sheen on all wall surfaces from Egg-shell to Semi-Gloss
 - c. Change Order #22 - Bryans Flooring - ASI18 Stage 124 Stair Treads
2. Timberlake Construction - Softball Hitting Facility
 - a. Change Order #17 - Moving air duct work above the netting
 - b. Change Order #18 - Sod and Temporary Irrigation
3. Timberlake Construction - Mustang Elementary Security Corridor
 - a. Change Order #007 - RFI #2 remove footing
 - b. Change Order #009 - Fire Alarm
 - c. Change Order #10 - #6, #8 and #9 grade related changes
 - d. Change Order #11 - Brick Wall Paint Modifications
 - e. Change Order #12 - Reconcile Payments on Change Orders #8, #9, #10 and #11
 - f. Change Order #13 - Project Contingency Return

I. Financial Consent Agenda

Motion to approve financial consent agenda. This motion, made by Todd Lovelace and seconded by Travis Helling, Passed.

Travis Helling: Aye, Sarah Lippencott: Aye, Todd Lovelace: Aye, Dr. Robert Rader: Aye, Toby Thompson: Aye

1. Encumbrance Registers
2. Change Orders Registers
3. Treasurer's Report
4. General Fund Revenue Analysis
5. Activity Fund Purpose of Accounts

J. Business

1. Discussion and possible board action to approve the naming of Elementary #9 to Sunset Hill Elementary School.

Motion to approve the naming of Elementary #9 to Sunset Hill Elementary School. This motion, made by Travis Helling and seconded by Todd Lovelace, Passed.

Travis Helling: Aye, Sarah Lippencott: Aye, Todd Lovelace: Aye, Dr. Robert Rader: Aye, Toby Thompson: Aye

2. Discussion and possible board action on the approval of the letter of substantial completion for the demolition of the old Mustang High School gym.

Motion to approve the letter of substantial completion for the demolition of the old Mustang High School gym. This motion, made by Todd Lovelace and seconded by Travis Helling, Passed.

Travis Helling: Aye, Sarah Lippencott: Aye, Todd Lovelace: Aye, Dr. Robert Rader: Aye, Toby Thompson: Aye

K. New Business This business, in accordance with Oklahoma Statutes, title 25- 311 (A)(9), is limited to any matter not known about or which could not have been reasonably foreseen prior to the time of posting this agenda.

No New Business

L. Executive Session: The Board of Education will consider and may vote to convene in Executive Session.

Did not convene into executive session.

1. Proposed executive session to discuss the employment, hiring, appointment, promotion, demotion, disciplining, or resignation of an employee. 25 O.S. Section 307 (B)(1). As listed on Schedule A, B & C.

M. Acknowledge Return to Open Session

N. Statement of Executive Session minutes by Board Clerk

O. Vote to approve or not approve the Superintendent's recommendation concerning employment as listed on Schedule "A".

Motion to approve Schedule A. This motion, made by Todd Lovelace and seconded by Travis Helling, Passed.

Travis Helling: Aye, Sarah Lippencott: Aye, Todd Lovelace: Aye, Dr. Robert Rader: Aye, Toby Thompson: Aye

P. Vote to approve or not approve the Superintendent's recommendation concerning employment as listed on Schedule "B".

Motion to approve Schedule B. This motion, made by Todd Lovelace and seconded by Travis Helling, Passed.

Travis Helling: Aye, Sarah Lippencott: Aye, Todd Lovelace: Aye, Dr. Robert Rader: Aye, Toby Thompson: Aye

Q. Vote to approve or not approve the Superintendent's recommendation concerning employment as listed on Schedule "C".

Motion to approve Schedule C. This motion, made by Todd Lovelace and seconded by Travis Helling, Passed.

Travis Helling: Aye, Sarah Lippencott: Aye, Todd Lovelace: Aye, Dr. Robert Rader: Aye, Toby Thompson: Aye

R. Adjournment

Time 7:06 PM

Motion to adjourn. This motion, made by Dr. Robert Rader and seconded by Travis Helling, Passed.

Travis Helling: Aye, Sarah Lippencott: Aye, Todd Lovelace: Aye, Dr. Robert Rader: Aye, Toby Thompson: Aye

Minutes Clerk

Board President



Schedule "A"
October 14, 2024

Employment				
Last Name	First Name	Replacing/New Position	Site/Assignment	Effective
Brownfield	Eugene	Zackri Parker	Transportation/Bus Driver	09/30/2024
Brownie	Erica	Sarah Gogle	CRI/ Spec Ed Teacher	10/07/2024
Duck	Travis	Mike Smith	Operations/Journeyman/Licensed Plumber	09/23/2024
Emillio	Stephanie	Christy Waller	MERC/Business Office Clerk	10/09/2024
Holland	Christina	Assistant Principal Substitute	MBI	10/01/2024
Massion	Loretta	Inez Henson	HZ/Spec Ed Teacher	10/02/2024
McCool	Jamie	Nanette Scott	MC/Spec Ed Paraprofessional	10/08/2024
Neal	Katherine	Ray Fendrych	Transportation/Bus Driver	10/07/2024
Parker	James	Jonathan Covey	Operations/Custodian	10/07/2024
Wasson	Amy	Tonya Hott	MC/Spec Ed Paraprofessional	09/16/2024
Whisenhunt	Sierra	Robin Adams	Transportation/Bus Driver	09/23/2024
Reassignments				
Last Name	First Name	From: Site/Assignment	Site/Assignment	Effective
Cornell	Amberlyn	ME/Noon Supervisor	ME/ Spec Ed Paraprofessional	10/10/2024
Hale	Mike	Transportation/Bus Driver	Transportation/Exec. Admin. Asst.	09/27/2024
Henson	Inez	HZ/ Spec Ed Teacher	HZ/Teacher	10/02/2024
Horinek	Denise	MEC/Site Paraprofessional	MERC/Receptionist	10/21/2024
Keith	Brian	MERC/Activity Fund Custodian	Operations/Custodial Manager	10/07/2024
Klassen	Marla	RWE/CN Cafeteria Assistant 7.5hrs	RWE/CN Cafeteria Assistant 6hrs	10/09/2024
Smith	Michelle	Transportation/Admin. Asst.	Operations/Admin. Asst.	10/21/2024
Vroman	Jeremy	MHS/Spec Ed Paraprofessional	MHS/LT Sub w/Benefits	10/08/2024
Resignations				
Last Name	First Name	From: Site/Assignment		Effective
Albrecht	Eric	Transportation/Bus Driver		10/11/2024
Duthile	Charlotte	MCE/Spec Ed Functional Skills Teacher		09/06/2024
Neel	James	PVE/CN Cafeteria Assistant		10/15/2024
Schneider	Reba	MHS/Spec Ed Teacher		10/07/2024
Scott	Nanette	MCE/Spec Ed FS Paraprofessional		09/06/2024
Sholer	Traci	Transportation/Bus Driver		01/01/2025
West	Jana	Operations/Exec. Administrative Asst		09/27/2024
Williams	Karen	MHS/CN Cafeteria Asst		09/23/2024
Wilson	Kenneth	Operations/Custodial Manager		10/09/2024
Wilson	Sue	HZ/ Teacher		09/27/2024
Termination				
Last Name	First Name	From: Site/Assignment		Effective
Floyd	Tanya	HZ/CN Cafeteria Assistant		10/09/2024



Schedule "B" October 14, 2024

Additional Duties				
Last Name	First Name	Assignment	Site	Effective
Brakebill	Heather	MS Multi-Sport (3 or More)	HZI	2024-2025
Burch	Blake	Archery MS	MNMS	2024-2025
Cambio	Zane	9th Asst. Football Coach	MHS	2024-2025
Evans	Antony	MS Multi-Sport (3 or More)	MHS	2024-2025
Farnham	Emily	Speech & Debate HS 1/2	MHS	2024-2025
Foster	Dakota	MS Multi-Sport (3 or More)	MMS	2024-2025
Garcia	Steve	Webmaster	MNMS	2024-2025
Garrett	Rondalyn	Asst 8th Girls Basketball	MNMS	2024-2025
Garrett	Rondalyn	MS Multi-Sport (2 Sports)	MNMS	2024-2025
Knight	Angela	Native American Club Sponsor	MCMS	2024-2025
Landry	Kimberly	MS Multi-Sport (2 Sports)	MHS	2024-2025
Leep	Lloyd	Asst 8th Gr Football (1/2)	MCMS	2024-2025
McCarty	Cynthia	Native American Club Sponsor	CRI	2024-2025
Pool	Jessica	District PD Comm Member	MBI	2024-2025
Ralls	Austin	9th Asst. Football Coach	MHS	2024-2025
Robison	Kaitlyn	E-Sports MS	MNMS	2024-2025
Sawyer	Christopher	MS Multi-Sport (2 Sports)	MMS	2024-2025
Sullivan	Ty	Asst 8th Gr Football (1/2)	MCMS	2024-2025
Williams	Benjamin	Native American Club Sponsor	MMS	2024-2025
Brock	Karissa	Homebased Instructional Services	Dist.	2024-2025
Brown	Alexis	Homebased Instructional Services	Dist.	2024-2025
Kennish	Beatrice	Homebased Instructional Services	Dist.	2024-2025
Swink	Kristina	Homebased Instructional Services	Dist.	2024-2025
Allen	Jenny	Mentor Teacher	Dist.	2024-2025
Aynes	Keith	Mentor Teacher	Dist.	2024-2025
Baca	Vanessa	Mentor Teacher	Dist.	2024-2025
Baker	Andra	Mentor Teacher	Dist.	2024-2025
Barnes	Cyndi	Mentor Teacher	Dist.	2024-2025
Blackwell	Amber	Mentor Teacher	Dist.	2024-2025
Brandon	Kari	Mentor Teacher	Dist.	2024-2025
Brown	Megan	Mentor Teacher	Dist.	2024-2025
Brown	Alexis	Mentor Teacher	Dist.	2024-2025
Burton	Amanda	Mentor Teacher	Dist.	2024-2025
Campbell	Kylie	Mentor Teacher	Dist.	2024-2025
Catelli	Sarah	Mentor Teacher	Dist.	2024-2025
Cavner	Kristina	Mentor Teacher (2)	Dist.	2024-2025
Chaisson	Leiha	Mentor Teacher	Dist.	2024-2025
Dunbar	Kaitlyn	Mentor Teacher (2)	Dist.	2024-2025
Dyche	Cindy	Mentor Teacher	Dist.	2024-2025
Eidson	Beka	Mentor Teacher	Dist.	2024-2025
Elliott	Malinda	Mentor Teacher	Dist.	2024-2025
Elmore	Shawn	Mentor Teacher	Dist.	2024-2025
Ervin	Dana	Mentor Teacher	Dist.	2024-2025
Evans	Mary	Mentor Teacher	Dist.	2024-2025
Farnham	Kyle	Mentor Teacher	Dist.	2024-2025
Fletcher	Max	Mentor Teacher	Dist.	2024-2025
Frederick	Courtney	Mentor Teacher	Dist.	2024-2025
Gatlin	Kelcy	Mentor Teacher	Dist.	2024-2025
George	Breanne	Mentor Teacher	Dist.	2024-2025
Glyckherr	Maria	Mentor Teacher	Dist.	2024-2025

Harney	Ruby	Mentor Teacher	Dist.	2024-2025
Henderson	Meradith	Mentor Teacher	Dist.	2024-2025
Henderson	Ashley	Mentor Teacher	Dist.	2024-2025
Holmes	Emily	Mentor Teacher	Dist.	2024-2025
Howard	Summer	Mentor Teacher	Dist.	2024-2025
Jackson	Holly	Mentor Teacher	Dist.	2024-2025
Keel	Jennifer	Mentor Teacher	Dist.	2024-2025
Keele	Robyn	Mentor Teacher	Dist.	2024-2025
Kenedy	Patrick	Mentor Teacher	Dist.	2024-2025
Kennish	Beatrice	Mentor Teacher	Dist.	2024-2025
Killebrew	Cindy	Mentor Teacher	Dist.	2024-2025
Lane	Alicia	Mentor Teacher	Dist.	2024-2025
LaRue	Amy	Mentor Teacher	Dist.	2024-2025
Llewellyn	Patricia	Mentor Teacher	Dist.	2024-2025
Manuel	Aron	Mentor Teacher	Dist.	2024-2025
Michael	Elizabeth	Mentor Teacher	Dist.	2024-2025
Miller	Eddie	Mentor Teacher	Dist.	2024-2025
Miller	Cherie	Mentor Teacher	Dist.	2024-2025
Miseldine	Michelle	Mentor Teacher	Dist.	2024-2025
Nguyen	Tresa	Mentor Teacher	Dist.	2024-2025
O'Bannon	Nicole	Mentor Teacher	Dist.	2024-2025
O'Nan	Jennifer	Mentor Teacher	Dist.	2024-2025
Penney	Amy	Mentor Teacher	Dist.	2024-2025
Pool	Jessica	Mentor Teacher	Dist.	2024-2025
Price	Chelsea	Mentor Teacher	Dist.	2024-2025
Ray	Robyn	Mentor Teacher	Dist.	2024-2025
Ray	Glendia	Mentor Teacher	Dist.	2024-2025
Reddish	Rebecca	Mentor Teacher	Dist.	2024-2025
Robinson	Mary Grace	Mentor Teacher	Dist.	2024-2025
Rosser	Allyson	Mentor Teacher	Dist.	2024-2025
Rother	Melissa	Mentor Teacher	Dist.	2024-2025
Sandefur	Christi	Mentor Teacher	Dist.	2024-2025
Schenk	Riley	Mentor Teacher	Dist.	2024-2025
Shackelford	Amber	Mentor Teacher	Dist.	2024-2025
Smith	Ryan	Mentor Teacher	Dist.	2024-2025
Snowden	Cheryl	Mentor Teacher	Dist.	2024-2025
Solberg	Lisa	Mentor Teacher	Dist.	2024-2025
Sparks	Brandy	Mentor Teacher	Dist.	2024-2025
Stokes	Hanna	Mentor Teacher	Dist.	2024-2025
Swink	Kristi	Mentor Teacher	Dist.	2024-2025
Teddy	Erin	Mentor Teacher	Dist.	2024-2025
Thatcher	Jana	Mentor Teacher	Dist.	2024-2025
Thomas	Amanda	Mentor Teacher	Dist.	2024-2025
Toblason	Erlin	Mentor Teacher	Dist.	2024-2025
Todd	Lisa	Mentor Teacher	Dist.	2024-2025
Tonay	Christina	Mentor Teacher	Dist.	2024-2025
Tucker	Erika	Mentor Teacher	Dist.	2024-2025
Vann	Marquita	Mentor Teacher	Dist.	2024-2025
Walker	David	Mentor Teacher	Dist.	2024-2025
Weidner	Corey	Mentor Teacher	Dist.	2024-2025
Wilson	Emily	Mentor Teacher	Dist.	2024-2025
Wolfe	Tom	Mentor Teacher	Dist.	2024-2025
Wright	Amy	Mentor Teacher	Dist.	2024-2025
Wyckoff	Kristin	Mentor Teacher	Dist.	2024-2025
Yates	Brandee	Mentor Teacher	Dist.	2024-2025



Schedule "C"
October 14, 2024

Guest Teacher			
Last Name	First Name	Site/Assignment	Effective
Ashbaugh	Michelle	District	2024-2025
Baker	Joy	District	2024-2025
Barron	Danielle	District	2024-2025
Brown	Rhonda	District	2024-2025
Brunson	Kallie	District	2024-2025
Coker	Patricia	District	2024-2025
Haney	Lisa	District	2024-2025
Jackson	Amberly	District	2024-2025
Johnson	Heather	District	2024-2025
Johnson	Stacey	District	2024-2025
Karpilo	Anthony	District	2024-2025
Lay	Hannah	District	2024-2025
McMurray	Charles	District	2024-2025
Pittman	Lisa	District	2024-2025
Popetsaitke	Glorietta	District	2024-2025
Robinson	Elizabeth	District	2024-2025
Russell	Karen	District	2024-2025
Ryan	Katelynn	District	2024-2025
Schill	Kristen	District	2024-2025
Schoening	Laurie	District	2024-2025
Swain	Karen	District	2024-2025
Thomas	Devin	District	2024-2025
Thomas	Jonathan	District	2024-2025
Valencia	Angela	District	2024-2025
Washburn	Janie	District	2024-2025
Watanabe	Robyn	District	2024-2025
Registered Nurse Substitute			
Last Name	First Name	Site/Assignment	Effective
Milburn	Shannon	District	2024-2025
Pittman	Lisa	District	2024-2025
Stangl	Janee	District	2024-2025
Bus Driver Substitute			
Last Name	First Name	Site/Assignment	Effective
Ratliff	Stacey	District	09/26/2024
Bronco Club 2024-2025 SY			
Last Name	First Name	Site	Effective
Beasley	Chaireka	MCE	2024-2025
Davis	Teresa	MCE	2024-2025
Dykes	Shelbi	MCE	2024-2025
Ezell	Melissa	MCE	2024-2025
Gray	Hannah	MCE	2024-2025
Joseph	Elsa	MT	2024-2025
Langham	Cinndy	PVE	2024-2025
Magno	Pamela	MV	2024-2025
Mejia	Guadalupe	RWE	2024-2025
Mowery	Charlie	MBI	2024-2025
Neal	Leslie	MCE	2024-2025
Peters	Amanda	ME	2024-2025
Risley	Ashlyn	MC	2024-2025

Previous Transfers (prior to January 1st, 2022)

Transfers previously granted by the school board will remain in effect unless the board of education takes action to deny a future year's attendance based upon discipline, or attendance as addressed within this policy. Parents/Guardians will be notified by July 15th of the district's decision to deny continuance. This discontinuance can be appealed to the school board according to this policy.

Transfer Application Overview & Timeline

The school district will not accept or deny a transfer based on ethnicity, national origin, gender, income level, disabling condition, proficiency in the English language, measure of achievement, aptitude or athletic ability. Parents/Guardians can request a transfer at any time. Receipt of applications will be documented by the district so that the district may review those applications in the order submitted for purposes of capacity limitations. The administration will notify parents/guardians of the decision to approve or deny within 30 calendar days of request receipt in writing by either hand-delivery, by U.S. Mail or electronic mail. If denied, the notification shall include an explanation including but not limited to any citation to the statute, regulation, or school district policy under which the denial was made; A copy or electronic link of the policy adopted by the district for determining the number of transfer students the school district has the capacity to accept; a copy or electronic link of 210:10-1-18.1 from the Administrative Code; and the date upon which the appeal will be due.

Upon notification of an approved transfer, the parents/guardian has 10 calendar days to initiate enrollment. Failure to do so may result in transfer revocation.

For existing transfers, the district will not require parents to resubmit a new transfer application each school year and will advance the previous application of an enrolled student amending only the grade placement of the student. A student shall be allowed to transfer to a district in which the parent or legal guardian of the student is employed as an employee as per 70 O.S. § 8-113.

State law does limit the ability of a student to transfer no more than two (2) times per school year to one or more school districts in which the student does not reside. Exceptions to this limit will exist for students in foster care. Students are legally entitled to reenroll at any time in his or her school district of residence. Any brother or sister of a student who transfers may attend the school district to which their sibling transferred as long as the school district has capacity in the grade level and the sibling does not meet a basis for denial as listed below. A separate application must be filed for each student so that the district can timely consider requests in the order applications are received.

It is the policy of the board of education that any legally transferring student shall be accepted by the district under the following circumstances:

1. The district has the capacity to accept the student at the grade level at the school site;
2. The transferring student has not been disciplined for:
 - a. violation of a school regulation,
 - b. possession of an intoxicating beverage, low-point beer, as defined by Section 163.2 of Title 37 of the Oklahoma Statutes, or missing or stolen property if the property is reasonably suspected to have been taken from a student, a school employee, or the school during school activities, or
 - c. possession of a dangerous weapon or a controlled dangerous substance while on or within two thousand (2,000) feet of public school property, or at a school event, as defined in the Uniform Controlled Dangerous Substances Act.

3. The transferring student does not have a history of absences. "History of absences" means ten or more absences in one semester that are not excused for the reasons provided in 70 O.S. § 10-105 or due to illness.

By the first day of January, April, July and October, the board of education shall establish the number of transfer students the district has the capacity to accept in each grade level for each school site within the district. The number of transfer students for each grade level at each site that the district has the capacity to accept will be posted in a prominent place on the school district's website. The district shall report to the State Department of Education the number of transfer students for each grade level for each school site which the district has the capacity to accept.

Capacity Determination

Capacity, determinations are specifically for the purpose of complying with Oklahoma state law (70 O.S. § 18-113.1) establishing guidelines to determine the capacity for Mustang Public Schools to accept transfer students as defined by law. Capacity is not intended to define district decisions related to staffing allocations or class size determinations for non-transfer students.

In making the decision to determine Capacity, the board of education shall review class size limits specified in 70 O.S. § 18-113.1 and multiply those limits times the number of specified classroom teachers employed by the school district at each grade level. If classroom space is not sufficient to accommodate that number of students due to a classroom being disproportionately sized, the district's capacity numbers will reflect a lesser amount based upon that classroom size. Mustang Public Schools recognizes the need to provide additional support in schools designated as School wide Title I sites. Capacity limits are smaller for these sites as described below.

The following calculations will be used to determine Program Capacity for schools **not** designated as School wide Title I school sites.

- **PK-4th Grades**

By site, the number of core grade level teachers per grade level x 20 students = capacity for that grade level.

- **5th -6th Grades**

By site, the number of English Language Arts sections per grade level x 20 students = capacity for that grade level.

- **7th-8th Grades**

By site, the number of English Language Arts sections per grade level x 25 students = capacity for that grade level.

- **9th-12th Grades**

By site, the number of English Language Arts sections per grade level x 28 students = capacity for that grade level.

The following calculations will be used to determine Program Capacity for schools designated as School wide Title I school sites.

- **PK-4th Grades**

By site, the number of core grade level teachers per grade level x 18 students = capacity for that grade level.

- **5th -6th Grades**

By site, the number of English Language Arts sections per grade level x 18 students = capacity for that grade level.

- **7th-8th Grades**

By site, the number of English Language Arts sections per grade level x 22 students = capacity for that grade level.

- 9th-12th Grades

By site, the number of English Language Arts sections per grade level x 25 students = capacity for that grade level.

As it relates to Capacity, "Student" is defined as any student currently enrolled in Mustang Public Schools, regardless of instructional delivery format.

As it relates to Capacity, "English Language Arts" includes all levels of English Instruction for each specific grade level (e.g. English 3 and AP English Language). Self-contained special education courses and special education related teacher maximums are defined elsewhere.

As it relates to Capacity, the "sections" of English Language Arts are defined as one regular class taught by at least one teacher for a time of 1 period in the school day.

Transfer Capacity Review

The school district shall enroll transfer students in the order in which they submit their applications. If the number of student transfer applications exceeds the capacity of the district, the district shall select transfer students in the order in which the district received the application.

Uniformed Military Services - Dependent Children

Students who are the dependent children of a member of the active uniformed military services of the United States on full-time active-duty status and students who are the dependent children of the military reserve on active duty orders shall be eligible for admission to the school district regardless of capacity of the district. Students shall be eligible for military transfer if:

1. At least one parent of the student has a Department of Defense issued identification card; and
2. At least one parent can provide evidence that he or she will be on active-duty status or active-duty orders, meaning the parent will be temporarily transferred in compliance with official orders to another location in support of combat, contingency operation or a national disaster requiring the use of orders for more than thirty (30) consecutive days and;
3. The student will be residing with a relative of the student who lives in the receiving school district or who will be living in the receiving school district within six (6) months of the filing of the application for transfer.

A student shall be considered in compliance with the residency provisions of Section 1-113 of this title if he or she is a student whose parent or legal guardian is transferred or is pending transfer to a military installation within the state while on active military duty pursuant to an official military order.

MPS shall accept applications by electronic means for enrollment including enrollment in a specific school or program within the school district and course registration for students. The Parent or legal guardian of a student shall provide proof of residence in the school district within ten (10) days after the published arrival date provided on official documentation. A parent or legal guardian may use the following addresses as proof of residence:

- a. a temporary on-base billeting facility,
- b. a purchased or leased home or apartment, or
- c. federal government or public-private venture off-base military housing. (70 O.S. § 8-103.1)

Transfer Acceptance

If accepted, a student transfer is granted for the existing school year and may continue to attend in future years. At the end of the school year, the district may deny continued transfer of the student due to disciplinary reasons or a history of absences. Parents will be responsible for transportation for accepted transfers.

Academic Program Capacity Reserved

Mustang Public Schools has placed an emphasis on diverse academic program offerings, specifically at the High School. Considering such, out of district transfer capacity has been reserved for innovative high school programs not offered in most other metro school districts. These include programs such as ROTC, Aviation, Outdoor Education, or Agriscience. Out of district transfer applicants choosing to participate in these programs may be considered priority candidates for approval regardless of capacity.

Automatic Approvals

If a parent receives notification from the State Department of Education their transfer has been automatically approved due to military, foster care or a teacher employment status situation, Mustang Public Schools may immediately revoke the transfer upon failure to meet qualifying approval criteria outlined in law; teacher hired but never shows for work; military deployment orders are rescinded; etc.

Transfer Denial & Appeal

If a transfer request is denied by the administration, the parent or legal guardian of the student may appeal the denial within ten (10) calendar days of notification of denial to the board of education. The appeal period begins 3 days after notification sent by US mail or the day after a notification sent by email or hand delivered. The appeal to the board of education shall be submitted to the office of the superintendent. The appeal shall include the following: The name, address and telephone number of the parent of the student and the student for whom the appeal is being taken; the date the district gave notice denying the transfer request; the basis for appealing the decision of the school district; and the name, address and telephone number of the legal representative, if applicable. The board of education shall consider the appeal at its next regularly scheduled board meeting if notice is provided prior to the statutory deadline for posting the agenda for the meeting. During the appeal, the board will review the action of the administration to make sure that the district policy was followed with regard to the denial of the transfer. The board of education will meet in an executive session to review the educational records of the student. If the policy was not followed, the board of education shall vote to overturn the denial and the transfer will be granted. Any board vote on the appeal must be taken in open session. The student's name should not be included in the agenda or in the motion. If the board of education votes to deny an appeal of a request to transfer, the board of education shall instruct the superintendent to provide notification of denial in writing to the parent of the student by either hand-delivery, by U.S. Mail, or by electronic mail. The notification shall include: An explanation, including the legal citation to the statute, regulation, or school district policy under which the denial was made; a copy of the policy adopted by the board of education for determining the number of transfer students the district has capacity to accept; a copy of the State Board of Education's prescribed form for an appeal; and a copy of 210:10-1-18.1 which identifies the Accreditation standard for appealing the denial of a student transfer. If the board of education votes to uphold the denial of the transfer, the parent or legal guardian may appeal the denial within ten (10) calendar days of the notification of the appeal denial to the State Board of Education. The parent or legal guardian shall submit to the superintendent of the district, a notice of appeal on the form prescribed by the State Board of Education. The superintendent will immediately provide copies of the appeal to each member of the board of education. Upon receipt of notice of an appeal, but not later than five (5) calendar days prior to the date at which the State Board of Education is scheduled to consider the appeal, the board of education may submit a written response to the appeal. Responses should not exceed five (5) pages. If not submitted by the parent, the board of education shall provide a copy of the policy adopted to determine the number of transfer students the district has the capacity to accept in each grade level for each school site within the district. The parent and the school district will have an

opportunity to appear in person or by authorized representative or by attorney to address the State Board at the meeting.

Athletics

Students who transfer into Mustang Public Schools shall retain varsity athletic eligibility according to "rule 8" from the Oklahoma Secondary Schools Athletics Association (OSSAA); amended 2024.

~~Athletics Capacity Exception~~

~~Due to the OSSAA's rule 8 exception, varsity eligible athletes choosing to transfer OUT of Mustang Public Schools will be recorded as such in the Central Enrollment Office. Upon the transfer window opening after the completion of the preceding school year, the number of athletic "transfers out" will be determined. This number of "transfers out" will be added to the capacity determination upon the opening of the transfer window prior to the published transfer capacity in July. This "additional capacity" number will be determined and placed upon the summer opening of the transfer window, on the school district website in the same location as capacity determinations published to meet state transfer law. Students' waitlisted from that same transfer window opening will be accepted in the order they were received per state law. Students will be accepted regardless of athletic enrollment, if they meet the acceptance criteria listed in the state law and do not exceed the district capacity levels.~~

Intra-District Transfer

Intra-district Transfers shall follow the same guidelines as out of district transfers. Employee preference is given regardless of capacity. When wait-listed, intra-district transfers will be given priority over out of district transfers regarding capacity and open spots at school sites. Discipline and attendance will be reviewed for each intra-district transfer application.

Transfer of Special education Students

If a transfer application is received for a child with disabilities to a school district other than the district of residence of the child pursuant to the Education Open Transfer Act, the following provisions shall apply:

1. The school district shall establish availability of the appropriate program, staff, and services prior to approval of the transfer;
2. Prior to the approval of the transfer of a child on an individualized education program (IEP), a joint IEP conference shall be required between the district of residence and the receiving district; and
3. Upon approval of the transfer, the receiving district shall claim the child in the average daily membership for state and for federal funding purposes and shall assume all responsibility for education of the child.

For state funding purposes, the State Department of Education shall include the appropriate grade level weight and all category weights to which the pupil is assigned pursuant to the provisions of Section 18-201.1 of this title when calculating State Aid pursuant to the provisions of Section 18-200.1 of this title, regardless of whether the receiving district provides education to the student using traditional in-class means or via online instruction. When applicable, the receiving district may apply to the Oklahoma Special Education Assistance Fund for assistance in meeting any extraordinary costs incurred.

REFERENCE: 70 O.S. §13-103.

Adopted: 12-99
Revised: 10-01
Revised: 08-03
Revised: 08-04
Revised: 07-06
Revised: 07-11-11

Revised: 01-21-14
Revised: 08-14-17
Revised: 08-14-19
Revised 12-13-21
Revised: 02-15-22
Revised 06-13-22
Revised: 06-27-24
Revised: 07-15-24
Revised: 08-12-24
Revised 11-11-24

CONTRACT APPROVAL MEMO



To: Mustang Board of Education
CC: Charles Bradley, Superintendent
Ryan McKinney, Assistant Superintendent of Secondary Schools *RM*

From: Karen Wilson, Executive Director of Student Services *KW*

Date: 10/23/24

Contract Vendor: OU Board of Regents **Time Frame:** July 1, 2024 thru June 30, 2025

Discussion, motion and possible action to approve entry into an agreement with the above-referenced vendor for the following services:

to promote collaboration in the delivery pre-employment transition services for participants with a documented disability transition from secondary school to post-secondary education programs and/or competitive employment.

Pre-Employment Transition Services Coordination
Pre-ETS COLLABORATIVE AGREEMENT
FY2025

SECTION I - PURPOSE

This Collaborative Agreement (“Agreement”), effective as of the latest date of signature of all Parties or the 1st day of July, 2024 whichever is later, is entered into by and between the following Parties, also referred to herein as “Team Members” to promote collaboration in the delivery of Pre-Employment Transition Services (also referred to herein as Pre- ETS) for participants with a documented disability transitioning from secondary school to post-secondary education programs and/or competitive employment; for individuals with disabilities who are enrolled in secondary education and are eligible, or potentially eligible, to receive vocational rehabilitation services (VR) provided by Oklahoma Department of Rehabilitation Services (DRS).

- Mustang Public Schools (also referred to herein as “Host School”);
- The Board of Regents of the University of Oklahoma, by and through University Outreach/College of Continuing Education’s National Center for Disability Education and Training (also referred to herein as “NCDET” or “University”).

The Rehabilitation Act of 1973 (Rehabilitation Act), as amended by the Workforce Innovation and Opportunity Act (WIOA), and the Individuals with Disabilities Education Act (IDEA), as amended, all require a formal mechanism in place to ensure coordination of transition services that are needed to provide a free appropriate public education to participants with a documented and to ultimately transition participants with documented disability to competitive integrated employment or post-secondary education.

The OBJECTIVE of this Agreement seeks to:

- Increase coordination between the Parties to identify and prepare participants with a documented way to move to post-secondary education and/or competitive integrated employment; based on participant need, considering strength, preferences, and interests.
- Improve transition planning by DRS and local education agencies (LEAs) for participants with disabilities to facilitate the development and implementation of that individual’s education program.
- Strengthen relationship between the Oklahoma State Department of Education (OSDE), Oklahoma Office of Workforce Development (OOWD), LEAs, higher education entities, and businesses to facilitate successful outcomes for participants a documented disability.
- Engage, involve and educate families to increase participant success in post-school activities.
- Increase the number of participants reaching their individual education plan (IEP) and the DRS individual plan for employment (IPE) goals.
- Increase professional learning opportunities and share resources.
- Increase job training and education opportunities for people who have traditionally faced barriers.

TERM

The Parties agree that the effective period of this Agreement shall be the latest date of signature of all Parties, or **July 1, 2024, whichever is the latter, through June 30, 2025.**

This Agreement may be renewed for two (2) additional twelve-month periods. Any renewals are contingent upon the Department of Rehabilitation Services renewing the Pre-Employment Transition Services Agreement with the University.

SECTION 2 – DEFINITIONS (for the purpose of this agreement):

2.1 **Workforce Innovation and Opportunity Act (WIOA):** Reauthorizes the Rehabilitation Act of 1973 as amended, that established VR (29 U.S.C. § 701 et seq.) and creates the Pre-ETS set-aside (29 U.S.C. § 730 (d)).

2.2 **Vocational Rehabilitation (VR):** a federal program which promotes, assesses, plans, develops and provides services for individuals with disabilities, consistent with their strengths, resources, priorities, concerns, abilities, capabilities, interests and informed choice, so they may prepare for and engage in gainful employment, as required by the Rehabilitation Act.

2.3 **Oklahoma Office of Workforce Development (OOWD):** carries out the vision of the Governor's Council for Workforce and Economic Development, provides technical assistance and coordinates strategic priorities and plans across education, training and economic agencies. Works to align and connect education and workforce resources, remove workforce barriers and better support Oklahoma employers and jobseeker.

2.4 **Individual Education Plan (IEP):** a written statement of the educational program required by IDEA for a participant with a disability designed to meet the participant's individual needs. The IEP has two general purposes: to set appropriate, measurable goals for the participant and to describe the specialized instruction and services the school district will provide for the participant.

2.5 **Individual Plan for Employment (IPE):** is required by the Rehabilitation Act, and is the roadmap developed jointly by the participant and the Vocational Rehabilitation counselor to help the participant with a disability reach a specific competitive, integrated employment goal.

2.6 **Individuals with Disabilities Education Act (IDEA):** is designed to ensure that all participants with a documented disability have available to them a Free and Appropriate Public Education (FAPE) that provides special education and related services designed to meet their unique needs and to prepare them for further education, employment and independent living; federal act codified at 20 U.S.C. § 1400 et seq.

2.7 **Local Education Agency (LEA):** a public board of education or other public authority legally constituted within a state for either administrative control or direction of, or to perform a service function for, public elementary schools or secondary schools in a city, county, township, school district or counties recognized in a state as an administrative agency for its public elementary schools or secondary schools; codified at 20 U.S.C. §1401 (19).

2.8 **A participant with a disability:** is an individual who is in an educational program; and

meets certain age requirements; and is eligible for and receiving special education or related services under IDEA; or is an individual with a disability for purposes of section 504 of the Rehabilitation Act.

2.9 Potentially Eligible: participants with a documented disability, including individuals ages 14-21 who have not applied or been determined eligible for VR services.

2.10 Competitive Integrated Employment: employment for an individual with a disability that is, among other things, compensated at a rate not lower than the minimum wage and is customary for the occupation and where the individual interacts with other persons without disabilities.

2.11 Pre-Employment Transition Services (Pre-ETS): activities provided through a subset of transition services, in partnership with LEAs, to help participants, and potentially eligible participants, with disabilities develop skills leading to success in employment and independent living after high school. These learning experiences are designed within an outcome-oriented process that promotes movement from school to post-school activities, including postsecondary education, vocational training, competitive integrated employment, financial literacy, and self-advocacy education to improve social and independent living skills. Pre-ETS are defined and authorized in accordance with 29

U.S.C. § 733.

The following are examples of activities that fall into the five required Pre-ETS categories:

- **Job Exploration Counseling:** discussion, activities, vocational evaluations or assessments on in-demand job opportunities intended to foster motivation and informed decision-making.
- **Work-Based Learning** – research and knowledge of work site tours, job shadowing, mentoring, internships, apprenticeships, short-term employment, volunteering, and on-the-job trainings;
- **Counseling on Post-Secondary Opportunities**—discussion and activities regarding college and other -post-secondary opportunities, academic and occupational training needed to succeed in the workplace, and providing resources that may be used to support individual participant success in education and training, such as disability support services and financial aid;
- **Workplace Readiness Training** (can be in a simulated or "real" work setting) - teaching social skills and independent living skills necessary to prepare for eventual employment, such as communication and interpersonal skills, financial literacy, transportation options, job-seeking skills, understanding employer expectations, and other "soft" skills necessary for employment; and
- **Self-advocacy**—training on rights and responsibilities; how to request accommodations or services and supports; communicating thoughts, concerns, and needs; peer-mentoring opportunities; and participating in leadership activities offered in educational or community settings.

SECTION 3 – RESPONSIBILITIES:

The Host School:

The school plays a significant role in the success of providing and coordinating transition services, specifically employment readiness instruction for participants with a documented disability. Schools are bound by the specific content in the Individuals with Disabilities Education Act (IDEA) for the provision of secondary transition services and by coordinating services with other agencies who will pay for or provide transition services. Pre-Employment Transition Services are not meant to reduce the responsibility of schools to provide transition services. The intent is to enhance the resources available to participants with a documented disability through collaboration. Host School understands and agrees that they will not be reimbursed by the University for any costs incurred as part of the Pre- ETS program.

The Host School will:

- Upon receipt of proof from NCDet that all NCDet personnel participant under this Agreement have passed the criminal background record check, allow the NCDet Pre-ETS staff access to DRS potentially eligible participants with a documented disability and/or DRS clients (in a group setting or one-on-one) to whom they can provide Pre-ETS instructional activities;
- work with the local DRS counselors to identify, recruit, and refer participants for vocational rehabilitation services;
- be responsible for collecting written parent authorization to allow their participant to participate in Pre-ETS activities;
- ensure school staff and/or a classroom teacher is present and assisting to ensure the highest engagement of the participants;
- communicate to the NCDet Pre-ETS staff and DRS (if applicable) any concerns brought forth by a participant;
- provide information to assist staff providing Pre-ETS activities that will support the learning needs, adaptations, and/or modifications of program participants;
- assist with outreach to identify participants with a documented disability and assessment of their potential need for transition services and pre-employment transition services;
- promote networking and collaboration among families, schools, community agencies and employers;
- share career assessment and planning information with DRS and Pre-ETS staff;
- work collaboratively to increased number of participants obtaining their IEP and IPE goals;
- assist with the development of additional school sites by speaking with potential school leadership; and
- maintain confidentiality regarding program participants.

NCDet:

The University of Oklahoma Outreach is a lifelong learning organization dedicated to helping individuals, businesses, groups, and communities transform themselves through knowledge. Established in 1965, the National Center for Disability Education and Training seeks to advance

independent living, employment, and career opportunities for people with disabilities through innovative training and direct service.

NCDDET will:

- work in collaboration with DRS counselors, school transition personnel, and other persons supporting DRS potentially eligible participants with a documented disability and/or DRS clients to provide Pre-ETS instructional activities in groups and/or individually;
- ensure its staff are trained and experienced in working with participants with a documented disability as well as developing business relationships;
- ensure its staff have successfully passed a criminal background check; and will provide the Host School proof prior to providing Pre-ETS activities,
- support the host school staff in planning for the transition of participants with a documented disability from school to post-school activities;
- work in collaboration with the teacher and current transition curriculum;
- work to increase employment and/or post-secondary participant success;
- work with local school districts to create greater access for participants with a documented disability and remove barriers into transition programs and activities;
- assist with outreach to identify participants with a documented disability and assessment of their potential need for transition services and pre-employment transition services;
- encourage community work experiences that provide the opportunity for participants with a documented disability to participate in skill development in community settings;
- promote networking and collaboration among families, schools, community agencies and employers;
- share career assessment and planning information with DRS and school staff;
- work with the local DRS counselors to identify, recruit, and refer participants for vocational rehabilitation services;
- communicate to Host School staff and DRS (if applicable) any concerns brought forth by a participant;
- assist with the development of additional school sites by speaking with potential school leadership; and
- maintain confidentiality regarding program participants.

Section 4 Special Terms and Assurances

A. Insurance

Each Party is hereby required to carry liability insurance or State of Oklahoma self-insurance adequate to compensate, in accordance with the limits of the Oklahoma Governmental Tort Claims Act, 51 O.S. 1991, sec 151, et seq., as amended, persons for injury to their person or property occasioned by an act of negligence by the party to be bound, its agents or employees. The Parties shall timely renew the policies to be carried pursuant to this section throughout the term of the Agreement, and provide evidence of such insurance and renewals upon request.

B. Equal Opportunity/Non-Discrimination

Each Party shall at all times comply with all federal laws relating to nondiscrimination, including, but not limited to, Presidential Executive Order 11246, as amended, and the Civil Rights Act of 1964, 42 U.S.C. §2000 et seq.; Section 504 of the Rehabilitation Act of 1973, 29 U.S.C. 794.; the Americans With Disabilities Act of 1990, 42 U.S.C. §12101 et seq.; Title IX of the Education Amendments of 1972, 20 U.S.C. §1681 et seq.; the Age Discrimination in Employment Act, 42 U.S.C. §6101 et seq.; and all amendments to these acts, and all requirements imposed by the regulations issued pursuant to these acts, including, but not limited to, providing equal opportunity, both to those seeking employment and those seeking services, without regard to race, color, religion, sex, national origin, age, or handicap.

Each Party is an Equal Opportunity Employer, a provider of services and/or assistance, and is in compliance with the 1964 Civil Rights Act, Title IX of the Education Amendments of 1972, Section 504 of the Rehabilitation Act of 1973, as amended and Executive orders 11246 and 11375. The Host School represents compliance with the Americans with Disabilities Act of 1990 (Public Law 101-336), all amendments to, and all requirements imposed by the regulations issued pursuant to this act.

C. Drug-Free Workplace

Each Party represents compliance in providing or continuing to provide a drug-free workplace in accordance with the Drug-Free Workplace Act of 1988, and implemented at 34 CFR Part § 85.600 et seq.

D. Modification

The Agreement may only be modified by mutual consent of the Parties in writing.

E. Cancellation

1. With Cause: In the event the Host School fails to meet the terms and conditions of the Agreement, or fails to provide services in accordance with the provisions of the Agreement, the University may, upon written notice of default transmitted via Certified Mail to the Host School, cancel the Agreement effective upon receipt of notice or at 5:00 PM on the fifth calendar day from the date the University mailed the notice, whichever occurs first. Such cancellation shall not be an exclusive remedy, but shall be in addition to any other rights and remedies provided for by law.

1. Without Cause: It is further agreed that the Agreement may be canceled by either Party by providing thirty (30) days prior written notice.

F. Access to and Retention of Records

The Host School shall maintain adequate records regarding the Pre-ETS program and participant participation. Authorized personnel of the University, U.S. Department of Education or other pertinent federal agencies, and authorized personnel of the Oklahoma Department of Rehabilitation Services, and other appropriate state entities shall have the right of access to records of Host School which are pertinent to the performance of the Agreement, in order to audit, examine, make excerpts and/or transcripts. The Host School shall be required to maintain all records for three (3) years after all pending matters are closed.

G. Compliance with State and Federal Laws

Each Party to this Agreement shall comply with all applicable state and federal laws, rules and regulations relevant to the performance of the Contract. Compliance shall be the responsibility of the each Party, without reliance on or direction by the other.

Each Party hereto agrees to be responsible for its own negligent acts and omissions and those of its employees and agents as provided by the Oklahoma Governmental Tort Claims Act, 51 O.S. 1991, sec 151, et seq., as amended.

If the University notifies the Host School of a possible compliance issue, the Host School must submit an explanation to the University within forty-five (45) days of the notification. If upon receipt of the explanation the University determines the Host School is out of compliance, the Host School will have 30 days to remedy the non-compliance. If after that time the University determines the Host School has not resolved the compliance issue, the University may take any or all, but not limited to, the following options:

1. suspension of the Contract;
2. withholding of additional Contracts;
3. requiring an immediate audit of all records pertaining to the Contract;
4. the University, within 21 days of receipt of reports, shall complete review;
5. the University may choose to make an allowance on any compliance issue if appropriate documentation for the non-compliance action can be furnished.

Neither Party shall be liable for any damages resulting from any delay in delivery or failure to give notice of delay that directly or indirectly results from the elements, acts of God, delays in transportation, or delays in delivery by any cause beyond the reasonable control of the Parties.

H. FERPA

Each Party to this Agreement agrees to abide by the limitations on redisclosure of personally identifiable information from education records as set forth in the Family Educational Rights and Privacy Act (34 CFR 99.33(a)(2))

I. Clean Air Act

Each Party agree to comply with all applicable standards, orders or regulations issued pursuant to the Clean Air Act, as amended, 42 U.S.C. § 7401 et seq. The Host School agrees to report each violation to the University, and understands and agrees that the University will, in turn, report each violation as required to assure notification to the appropriate Environmental Protection Agency Regional Office.

J. Employment Relationship

This Agreement does not create an employment relationship. Individuals performing services required by the Agreement are not considered employees of the University. The Host School's employees shall not be considered employees of the University for any purpose, and as such shall not be eligible for benefits accruing to University employees.

The University shall provide access to staff as needed to meet the requirements contained herein.

K. Contract Jurisdiction

The Agreement will be governed in all respects by the laws of the State of Oklahoma. The State of Oklahoma, District Court of Oklahoma County will be the venue in the event any legal action is filed by the Host School or the University to enforce or to interpret provisions of the Agreement.

This Agreement is the product of negotiations between the Parties, each of which has had the opportunity to consult counsel prior to the execution hereof. Therefore, the Parties agree that if this Agreement needs to be interpreted by any court (or other tribunal) having jurisdiction, no conclusions or inferences of the law shall be drawn in favor of or against either Party on the basis of which Party drafted the term or provision at issue.

L. Severability

If any provision under the Agreement, or its application to any person or circumstance, is held invalid by any court of competent jurisdiction, such invalidity does not affect any other provision of the Agreement or its application that can be given effect without the invalid provision or application.

M. Ownership and Copyrights

All curriculum, instructional materials, software, reports, and videos (hereinafter "Intellectual Property") are being developed exclusively for the University or purchased by the University and shall be the property of the University. Intellectual Property created and copyrighted or trademarked by the other Party outside of the Contract shall be retained by same. This article shall not be construed to alter or diminish ownership rights provided under state or federal law or regulations.

N. Accessibility

Pursuant to Title 74, Section 85.7d and OAC 580:15-6-22 electronic and information technology procurements, agreements, and contracts shall comply with applicable Oklahoma Information Technology Accessibility Standards issued by the Oklahoma Office of State Finance. EIT Standards may be found at www.ok.gov/DCS/Central_Purchasing Upon request, the Host School shall provide a description of conformance with the applicable Oklahoma Information Technology Accessibility Standards for the proposed product, system or application development/customization by means of either a Voluntary Product Accessibility Template (VPAT) or other comparable document.

O. Entire Agreement

This Agreement constitutes the entire Agreement and understanding between the Parties and supersedes all prior and/or contemporaneous discussions, representations, or contracts, whether written or oral, of the Parties relating to the work to be performed.

Section 5: Signatures

The Parties hereto agree that they may conduct the transaction by electronic means and hereby state that electronic signature shall have the same force and effect as an original signature.

THE HOST SCHOOL REPRESENTS THAT IT HAS READ AND UNDERSTOOD THE TERMS OF THIS AGREEMENT AND MADE NO CHANGES TO THE TERMS OF THIS AGREEMENT. BY PLACING THE SIGNATURE OF ITS AUTHORIZED REPRESENTATIVE, THE HOST SCHOOL AGREES TO BE BOUND BY THIS AGREEMENT.

Host School

Signature

Date

Print Name and Signatory Title

CONTRACT APPROVAL MEMO



To: Mustang Board of Education
CC: Charles Bradley, Superintendent
~~Jeff Landes, Chief Financial Officer~~
Dr. Jason Pittenger, Assistant Superintendent
Ryan McKinney, Assistant Superintendent
Stacy Edwards, Assistant Superintendent

A handwritten signature in blue ink, likely belonging to Dr. Jason Pittenger, written over the name.

From: Dr. Karen Wilson, Exe Director of Student Services 

Board Meeting Date: November 11, 2024

Contract Vendor: Strategic Educational Solutions, LLC **Time Frame:** November 11, 2024 - May 21, 2025

Amount: \$ 65,000.00 **Fund:** 11 **Project:** 621

New Contract: **Renewal Contract:** (check one)

Discussion, motion and possible action to approve entry into an agreement with the above-referenced vendor for the following items or services:

Company to provide special education daily services with students who qualify under IDEA for special education services.

AGREEMENT FOR PROVISION OF SPECIAL EDUCATION SERVICES

THIS AGREEMENT ("Agreement") is entered into as of the ___ day of November 2024, by and between:

MUSTANG PUBLIC SCHOOL DISTRICT, a public school district located in Oklahoma ("District"), with its principal address at:
909 S Mustang Rd, Mustang, OK 73064,
and

STRATEGIC EDUCATIONAL SOLUTIONS LLC, an Oklahoma limited liability company ("Contractor"), with its principal address at:
3901 Sara Park Dr. Mustang, OK 73064.

WHEREAS, the District requires the services of skilled professionals to provide specialized educational services to students with severe intellectual disabilities, autism spectrum disorders, multiple disabilities, and significant physical impairments; and

WHEREAS, the Contractor possesses the necessary expertise and agrees to furnish qualified personnel to provide such services;

NOW, THEREFORE, in consideration of the mutual promises contained herein, the parties agree as follows:

1. Scope of Services

1.1 The Contractor agrees to furnish qualified personnel to deliver specialized educational services to students of the District, aged 3-21, in accordance with applicable federal and state laws, including but not limited to the Individuals with Disabilities Education Act (IDEA), Section 504 of the Rehabilitation Act, and the Americans with Disabilities Act (ADA).

1.2 The services to be provided by the Contractor's qualified personnel shall include, but are not limited to, the following:

- *Instruction:* Tailored, individualized instruction to address each student's unique cognitive, physical, and emotional needs.
- *Functional Life Skills Training:* Development of essential daily living skills, including but not limited to personal hygiene, meal preparation, self-care, communication, and safety in community settings.
- *Behavior Management:* Implementation and monitoring of individualized Behavior Intervention Plans (BIPs) to support positive behavior change.
- *Individualized Education Plan (IEP) Implementation:* Development, execution, and continuous assessment of IEPs, with timely progress reports as required by applicable laws and District policies.

CONTRACT FOR SPECIAL EDUCATION SERVICES

- *Curriculum Modification and Adaptation:* Customization of educational content to align with the unique cognitive and physical capabilities of the students, ensuring compliance with state and federal educational standards.
- *Assistive Technology Integration:* Incorporation of assistive technologies such as communication devices, adaptive tools, and training on their effective use.
- *Collaboration with Specialists:* Active and regular participation in multi-disciplinary team meetings, including but not limited to meetings with speech-language pathologists, occupational therapists, physical therapists, and other relevant professionals.
- *Data Collection and Progress Reporting:* Systematic documentation of student progress in all areas of service provision, with detailed, written reports provided to the District on a weekly basis.
- *Parental Communication and Training:* Ongoing communication with parents or legal guardians, including providing strategies and resources for home support, and facilitating parental involvement in IEP meetings as required by law.
- *Transition Planning:* Development of individualized transition plans to prepare students for post-school life, including coordination with vocational rehabilitation services where applicable.

1.3 The District agrees to provide the necessary curriculum, classroom supplies, specific assistive technology required for students as needed, sensory items for students as needed, special seating arrangements, and any additional resources required for the qualified personnel to effectively perform their duties.

2. Personnel Qualifications

2.1 The Contractor warrants and represents that all personnel assigned to provide services under this Agreement shall be fully qualified, certified, and/or licensed under applicable state and federal law to perform the services required herein.

2.2 The Contractor shall provide proof of credentials, licensure, and certifications for each individual providing services under this Agreement upon request by the District, and shall maintain such qualifications throughout the duration of this Agreement.

2.3 The Contractor agrees to comply with all background check requirements mandated by federal, state, and District policies prior to assigning personnel to provide services within the District.

3. Term and Schedule of Services

3.1 The term of this Agreement shall commence on _____, 2024, and shall continue through _____, 2025, unless terminated earlier pursuant to the provisions of this Agreement.

CONTRACT FOR SPECIAL EDUCATION SERVICES

3.2 The Contractor's qualified personnel shall provide services to the District during regular school hours and on a schedule mutually agreed upon by the parties. Any services required outside of regular school hours, including but not limited to preparation, grading, lesson planning, or parent communication, shall be provided in accordance with the terms of compensation set forth herein.

4. Compensation and Invoicing

4.1 In consideration for the services provided by the Contractor, the District agrees to compensate the Contractor at the mutually agreed hourly rate of \$75 per hour for all services rendered pursuant to this Agreement. The Contractor is authorized to work up to 40 hours per week and shall not exceed this amount without prior written authorization from the District. The Contractor shall submit detailed, itemized invoices on a monthly basis, on the last business day of the month, specifying the dates and hours of services provided, the names of personnel performing the services, and a summary of the services rendered.

4.2 Payment of invoices shall be due within seven (7) calendar days of the District's receipt of the invoice.

4.3 In the event that payment is not made within three (3) calendar days of the invoice due date, the Contractor shall be entitled to charge interest on the outstanding balance at a rate of 1.5% per month, or the highest rate permitted by law, whichever is lower.

5. Confidentiality and FERPA Compliance

5.1 Strategic Educational Solutions LLC acknowledges that the qualified professional personnel it provides may have access to student records and other personally identifiable information while delivering services under this Agreement. The Contractor agrees to comply with the Family Educational Rights and Privacy Act (FERPA) and all other applicable federal and state laws and regulations governing the confidentiality of student information.

5.2 The District shall provide the qualified personnel with access to a FERPA-compliant system for communication between its qualified personnel and parents/legal guardians, as well as for the secure transmission of any confidential or sensitive student data.

5.3 Upon termination or expiration of this Agreement, Strategic Educational Solutions LLC agrees that its qualified personnel will return all student records and confidential information in their possession to the District and will cease any further use or dissemination of such information.

CONTRACT FOR SPECIAL EDUCATION SERVICES

6. Insurance and Liability

6.1 The Contractor shall, at its sole expense, maintain at all times during the term of this Agreement the following insurance coverages, with limits no less than the amounts specified below:

- Professional Liability Insurance: \$3,000,000 per occurrence and \$3,000,000 aggregate.
- General Liability Insurance: \$2,000,000 per occurrence and \$ \$2,000,000 general aggregate.
- Cyber Liability Insurance: \$250,000 per occurrence and \$250,000 aggregate.

6.2 The Contractor agrees to provide proof of insurance coverage upon execution of this Agreement and upon request by the District.

6.3 The Contractor's liability for any claims arising under this Agreement shall be limited to the amounts of insurance coverage maintained under this Agreement, and the District agrees to hold the Contractor harmless to the extent such coverage is in place.

7. Termination

7.1 This Agreement may be terminated by either party upon thirty (30) days' prior written notice to the other party. In the event the District terminates this Agreement prior to the expiration date, the District agrees to make payment for all services rendered up to the date of termination.

7.2 In the event of a material breach of this Agreement by either party, the non-breaching party may terminate the Agreement immediately upon written notice to the breaching party, provided the breaching party has failed to cure the breach within ten (10) days of receipt of written notice specifying the breach.

8. Force Majeure

8.1 Neither party shall be liable for any delay or failure to perform its obligations under this Agreement due to causes beyond its reasonable control, including but not limited to acts of God, natural disasters, pandemics, war, civil unrest, strikes, or governmental actions.

8.2 In the event of a force majeure that impacts the ability to provide in-person services, the Contractor agrees to transition all services to a virtual format, and to work with parents and the District to develop individualized virtual care plans.

9. Indemnification

CONTRACT FOR SPECIAL EDUCATION SERVICES

9.1 The Contractor agrees to indemnify, defend, and hold harmless the District, its officers, employees, agents, and representatives from any and all claims, damages, liabilities, or expenses (including reasonable attorneys' fees) arising from or related to the Contractor's performance under this Agreement, except to the extent such claims arise from the negligence or willful misconduct of the District.

10. Governing Law and Dispute Resolution

10.1 This Agreement shall be governed by and construed in accordance with the laws of the State of Oklahoma, without regard to its conflict of laws principles.

10.2 Any disputes arising out of or relating to this Agreement shall first be submitted to mediation. If mediation fails, the dispute shall be resolved through binding arbitration in accordance with the rules of the American Arbitration Association, with the arbitration to be conducted in the State of Oklahoma.

11. Entire Agreement and Amendments

11.1 This Agreement constitutes the entire understanding between the parties with respect to the subject matter herein and supersedes all prior discussions, agreements, or understandings, whether written or oral.

11.2 This Agreement may be amended only by a written instrument signed by both parties.

SIGNATURES

Mustang Public School District

By: _____

Name: _____

Title: _____

Date: _____

Strategic Educational Solutions LLC

By: _____

Name: _____

Title: _____

Date: _____

Board of Education MEMO



To: Mustang Board of Education
CC: Charles Bradley, Superintendent

From: Dr. Jason Pittenger, Assistant Superintendent, Operations 
Supplemental Cleaning Agreement

Date: 11/6/24

Contract Vendor: Southwest Cleaning **Time Frame:** _____

Discussion, motion and possible action to approve supplemental contract with Southwest Cleaning. The board would give the superintendent authority to approve up to 8 positions as needed to fill in Mustang vacancies from resignations and retirements to maintain staffing levels appropriate to clean our facilities.



Professional Commercial/Janitorial
www.southwestcleaningservices.net

11-06-2024

To Jason Pittenger,
Assistant supervisor of Operations
Mustang Public Schools

From Bill Donnelly
Southwest Cleaning,

Jason as requested, Southwest Cleaning will commit, as needed, to provide, up to 8 more, full time custodians,
to clean at Mustang Public schools.

This contract would last until the end of the 2024-2025 school year.
Our daily rate for a full time custodian would be \$178.00,per day.
This contract will begin on a date approved by the Mustang School Board.

These positions would have to be authorized, through the board authority given to the Superintendent or his designee, as needed, to fill open custodial positions, vacated by resignation, retirement, or other means.

The contract would end on the last day of the 2024-25 school year, May 30,2025

Approved by Bill Donnelly, President
Southwest Cleaning.

Approved by Mustang School Board

Date -----

Memo

To: Charles Bradley, Stacy Edwards, Ryan McKinney

SE

[Signature]

From: Robbyn Glinsmann

Date: October 29, 2024

Re: Computer Science Textbook Adoption Committee 2024-2025

Please discuss, consider, and vote on the following recommendations of the Computer Science Textbook Adoption Committee members:

- Misty Eidson - Director of Elementary Curriculum and Instruction
- Dr. Robbyn Glinsmann - Director of Intermediate & Middle School Curriculum
- Shanda Cummings - Director of HS Curriculum & Educational Technology
- Gina Sewell-Delaney - Intermediate Teacher, Horizon Intermediate
- Chana'e Jones - Middle School Teacher, Central Middle School
- Carrie Hixon - High School Teacher, Mustang High School
- Jessica Holman - High School Teacher, Mustang High School
- Kameron Hill - Administrator, Mustang North Middle School
- Amanda Brown - Parent, Mustang Public Schools



Memo

From: Dr. Michael Raiber 

To: Mr. Ryan Mckinney, Mr. Charles Bradley, and the Mustang School Board of Education

Date: 10/29/24

Re: Fine Arts Textbook Adoption Committee

I respectfully request the following faculty members be appointed to the 2024-25 Fine Arts textbook adoption committee:

Name	Genre	Grade Levels
Ryan Edgmon	Band	6-12
Sohailah Stout	Vocal Music	6-12
Jennifer Hooten	Elementary General Music	pK-5
Tina Fruit	Elementary Visual Art	pK-4
Vanessa McIntire	Int./Secondary Visual Art	5-12
Emily Farnham	Theatre/Speech & Debate	6-12
Gina Thompson	Humanities/General Studies	9-12

Change Order MEMO



To: Mustang Board of Education
CC: Charles Bradley, Superintendent

From: Dr. Jason Pittenger, assistant Superintendent, Operations 

Date: 10/08/24

Contract Vendor: CADE Construction _____ **Time Frame:** _____

Discussion, motion and possible action to approve the potential change order with the Construction Manager at-Risk:

New Elem #9 C/O #23 ASI 19 - Mezzanine Wall

PCO #23 includes all material, labor and equipment to extend the far South wall of the mezzanine storage area from the stage below per MPS. The far south wall was previously 4' tall and open to the stage below but will now be fully enclosed, and access controlled, secured storage area.

Contingency will be used in the amount of \$4,805



PCO #023

CADE Construction
701 W Sheridan Ave Suite 108
Oklahoma City, Oklahoma 73102
Phone: +14054106072

Project: 23-04 - Elementary #9
4800 S. Sara Road
Oklahoma City, Oklahoma 73064

Prime Contract Potential Change Order #023: ASI 19 - Mezzanine Stage Wall

TO:	Mustang Public Schools 909 S. Mustang Road Mustang, Oklahoma 73064	FROM:	CADE Construction 701 W. Sheridan Avenue Suite 108 Oklahoma City, Oklahoma 73102
PCO NUMBER/REVISION:	023 / 0	CONTRACT:	23-04 - Elementary #09
REQUEST RECEIVED FROM:		CREATED BY:	Blake Burden (CADE Construction)
STATUS:	Approved	CREATED DATE:	10/14/2024
REFERENCE:	Attached CO / ASI 19	PRIME CONTRACT CHANGE ORDER:	None
FIELD CHANGE:	No		
LOCATION:		ACCOUNTING METHOD:	Amount Based
SCHEDULE IMPACT:		PAID IN FULL:	No
EXECUTED:	No	SIGNED CHANGE ORDER RECEIVED DATE:	
		TOTAL AMOUNT:	\$0.00

POTENTIAL CHANGE ORDER TITLE: ASI 19 - Mezzanine Stage Wall

CHANGE REASON: Client Request

POTENTIAL CHANGE ORDER DESCRIPTION: (The Contract Is Changed As Follows)

PCO #23 - ASI 19 - Mezzanine Stage Wall - \$4,805.00

PCO #23 includes all material, labor and equipment to extend the far south wall of the mezzanine to the structure above to enclose the mezzanine storage area from the stage below per MPS. The far south wall was previously 4' tall and open to the stage below but will now be a fully enclosed, access controlled, secured storage area.

ATTACHMENTS:

[Arrow - ASI #19 Mezzanine Wall.pdf](#) , [Cherokee Painting - ASI 19 Mezz Stage Wall.pdf](#)

#	Budget Code	Description	Amount
1	09-102-S.O Painting - Cherokee Painting	ASI 19 - Tape Bed & Paint	\$1,940.00
2	09-100-S.O Gypsum Board Assemblies & Ceiling Systems - Arrow	ASI 19 - Framing, Insulation & Drywall	\$2,550.00
3	01-103-L.O Project Manager	Staff Cost	\$315.00
4	01-040-O.O Contingency,Other	Utilize Contingency	\$(4,805.00)
Grand Total:			\$0.00

Heath Tate (MA+ Architecture)
4000 N. Classen Boulevard Suite 100N
Oklahoma City, Oklahoma 73118

Mustang Public Schools
909 S. Mustang Road
Mustang, Oklahoma 73064

CADE Construction
701 W. Sheridan Avenue Suite 108
Oklahoma City, Oklahoma 73102

SIGNATURE DATE 10/24/2024

SIGNATURE DATE

SIGNATURE DATE 10/24/24

Project: C 2411 - Mustang PS - ES #9

1. Change Order Title: <u>ASI #19 - STOR 400 wall to deck</u>	2. Number <u>COR 002</u>
3. Change Order Requested By: <u>Caleb Manning</u>	3. Date <u>10.4.24</u>
5. Owner/Architect/Engineer Change Order Request Number	<u>CO 2</u>
6. Material	<u>\$ 991.07</u>
7. Equipment	<u>\$ 24.00</u>
	8. Material and Equipment Subtotal <u>\$ 1,015.07</u>
	9. Sales Tax <u>0.0%</u> <u>\$ -</u>
10. Labor <u>24</u> Manhours @ <u>\$ 34.00 /Hour</u>	<u>\$ 816.00</u>
11. PM/Estimating <u>1</u> Manhours @ <u>\$ 45.00 /Hour</u>	<u>\$ 45.00</u>
12. Labor Insurance and Taxes	<u>30%</u> <u>\$ 258.30</u>
13. Small Tools	<u>5% of Labor</u> <u>\$ 40.80</u>
14. Out of Town Expenses	<u>0% of Labor</u> <u>\$ -</u>
	15. Labor Sub-Total <u>\$ 1,160.10</u>
16. Equipment Rental	
Scissor Lift <u>8</u> Hours @ <u>3.00 /Hour</u>	<u>\$ 24.00</u>
SkyTrack _____ Hours @ <u>30.00 /Hour</u>	<u>\$ -</u>
Hoisting _____ Hours @ <u>125.00 /Hour</u>	<u>\$ -</u>
Scaffold _____ Hours @ <u>20.00 /Hour</u>	<u>\$ -</u>
	17. Equipment Rental Sub-Total <u>\$ 24.00</u>
18. Indirect Costs	
	19. Change Order Sub-Total Costs <u>\$ 2,175.17</u>
	20. Overhead <u>10%</u> <u>\$ 217.52</u>
	21. Sub-Total <u>\$ 2,392.69</u>
	22. Profit <u>5%</u> <u>\$ 119.63</u>
	23. (DEDUCTS)
	24. Sub-Total <u>\$ 2,512.32</u>
	25. Add'l Insurance Premiums
	26. Bond Premium <u>1.5%</u> <u>\$ 37.68</u>
	27. Total Change Order Cost
	<u>\$ 2,550.00</u>
28. Additional Calendar Days Required <u>1.5</u>	

29. Description of Additional Work

ASI # 19 - The owner has requested that the south 4' tall wall of the mezzanine be extended to the structure above to enclose the mezzanine storage area from the stage below. This change includes framing, drywall and insulation extended to the deck.

Submitted By: Caleb Manning Title: Project Manager - OKC DIV

Cherokee Painting, LLC.

8833 SE 29th St.

Midwest City, OK 73110

Cell # 405-250-2560 Office # 405-610-7620

E-mail jrosser@cherokeepainting.com

October 2, 2024

REQUEST FOR CHANGE ORDER

Attn: Blake Burden - Cade
From: Joe Rosser
Subj: MPS Elem No. 9
Re: ASI-019

This proposal, if accepted, shall be made a part of any contract entered into, either by attachment or direct incorporation. Pricing is offered per plans or as noted below. Any of the following exclusions may be waived in this proposal, if either, specific pricing is provided or if an item is directly waived in our proposal. If you are unsure of any of the items listed below, please call our office.

Cherokee Painting proposes to furnish the labor, material, equipment and necessary equipment to complete the above-mentioned project with the following scope.

1. Provide and install additional Tape & Bed and Paint on the new extended walls indicated on plans.

TOTAL

\$ 1,940.00

If you have any questions please don't hesitate to contact me.



Joe Rosser
Project Manager



ARCHITECT'S SUPPLEMENTAL INSTRUCTION No. 019

Date: September 24, 2024 Job #: 1123E96
To: Blake Burden
Company: CADE Construction
Project: Mustang PS Elementary School #9
From: Justin Mitchell



Oklahoma City + Norman

Phone: 405.525.8806
www.maplusarch.com

ASI DESCRIPTION:

The owner has requested that the south 4' tall wall of the Mezzanine be extended to to the structure above to enclose the mezzanine storage area from the stage below. Attached are sheets A112 and A305 showing the approximate dimensions of additional wall for this change.

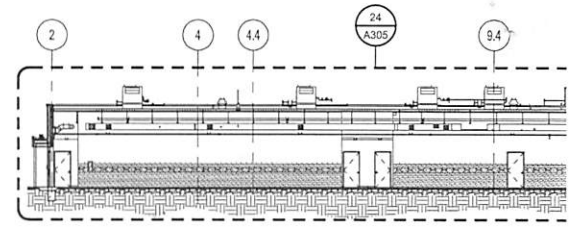

14 OVERALL E/W BLDG SECTION
 SCALE: 1/16" = 1'-0"
 REFER: 63-A110

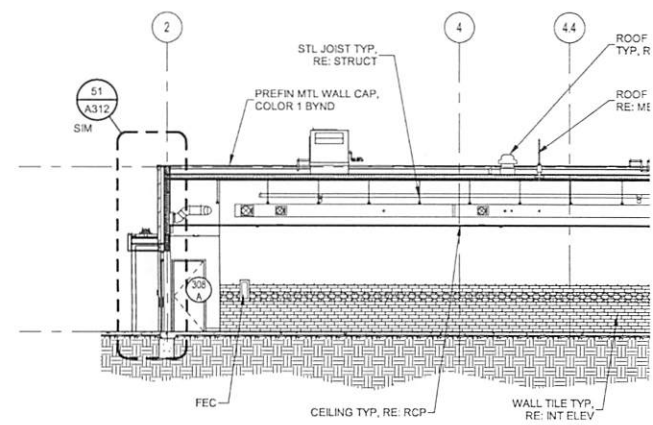

24 E/W BLDG SECTION T
 SCALE: 1/8" = 1'-0"
 REFER: 14-A305

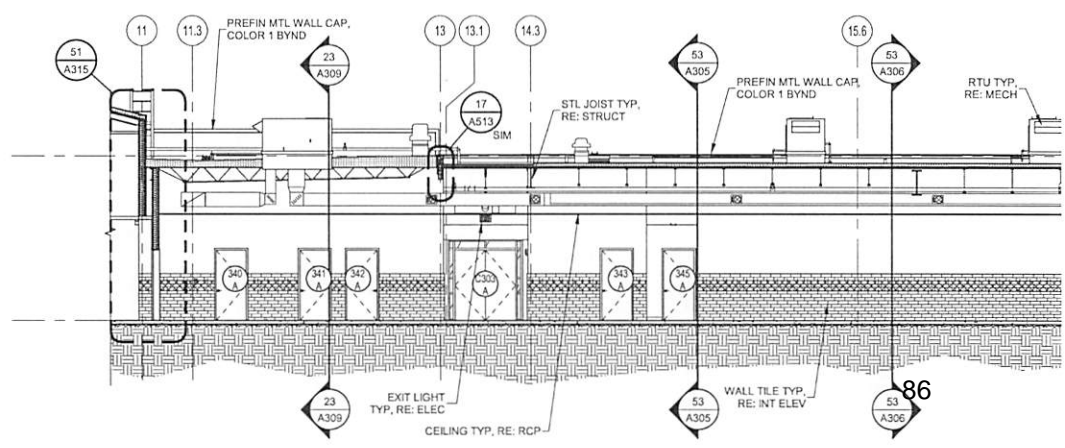

44 E/W BLDG SECTION T

Change Order MEMO



To: Mustang Board of Education
CC: Charles Bradley, Superintendent

From: Dr. Jason Pittenger, assistant Superintendent, Operations



Date: 10/08/24

Contract Vendor: CADE Construction **Time Frame:** _____

Discussion, motion and possible action to approve the potential change order with the Construction Manager at-Risk:

New Elem #9 C/O #24 Ellsworth - utilize earthwork allowance

PCO #24 includes all material and laborcost to touch up rock at the drives and parking lots due to weather, washout, traffic,etc.

Earthwork Allowance included in contingency - \$75,000

Earthwork Allowance used - \$32,265

Earthwork Allowance remaining - \$42,735

Contingency will be used in the amount of \$32,265.00

CADE Construction
701 W Sheridan Ave Suite 108
Oklahoma City, Oklahoma 73102
Phone: +14054106072

Project: 23-04 - Elementary #9
4800 S. Sara Road
Oklahoma City, Oklahoma 73064

Prime Contract Potential Change Order #024: Ellsworth - Utilize Earthwork Allowance

TO:	Mustang Public Schools 909 S. Mustang Road Mustang, Oklahoma 73064	FROM:	CADE Construction 701 W. Sheridan Avenue Suite 108 Oklahoma City, Oklahoma 73102
PCO NUMBER/REVISION:	024 / 0	CONTRACT:	23-04 - Elementary #09
REQUEST RECEIVED FROM:	Gumaro Herrera (Ellsworth Construction OKC)	CREATED BY:	Blake Burden (CADE Construction)
STATUS:	Approved	CREATED DATE:	10/17/2024
REFERENCE:	Attached CO	PRIME CONTRACT CHANGE ORDER:	None
FIELD CHANGE:	No		
LOCATION:		ACCOUNTING METHOD:	Amount Based
SCHEDULE IMPACT:	0 days	PAID IN FULL:	No
EXECUTED:	No	SIGNED CHANGE ORDER RECEIVED DATE:	
		TOTAL AMOUNT:	\$0.00

POTENTIAL CHANGE ORDER TITLE: Ellsworth - Utilize Earthwork Allowance

CHANGE REASON: Allowance

POTENTIAL CHANGE ORDER DESCRIPTION: *(The Contract Is Changed As Follows)*
PCO #24 - Ellsworth Paving - Utilize Earthwork Allowance - \$32,265.00

PCO #24 includes all material and labor cost to touch up rock at the drives and parking lots due to weather, washout, traffic, etc.

Earthwork Allowance Included within Contingency - \$75,000.00
Earthwork Allowance Utilized to Date - \$32,265.00
Earthwork Allowance Remaining - \$42,735.00

ATTACHMENTS:

[Ellsworth - Rock Touch Up at Drives.pdf](#)

#	Budget Code	Description	Amount
1	03-101-S.O Site Paving - Ellsworth Paving	Rock Touch Up at Drives - Utilize Earthwork Allowance	\$31,005.00
2	01-103-L.O Project Manager	Staff Cost	\$1,260.00
3	01-040-O.O Contingency.Other	Utilize Earthwork Allowance	\$(32,265.00)
Grand Total:			\$0.00

Heath Tate (MA+ Architecture)
4000 N. Classen Boulevard Suite 100N
Oklahoma City, Oklahoma 73118

Mustang Public Schools
909 S. Mustang Road
Mustang, Oklahoma 73064

CADE Construction
701 W. Sheridan Avenue Suite 108
Oklahoma City, Oklahoma 73102

SIGNATURE DATE 10-24-2024

SIGNATURE DATE

SIGNATURE DATE 10/24/24

PCO REQUEST



DATE: 10/11/2024
 PROJECT: MPS Elementary #9
 LOCATION SW 44TH/S SARA ROAD

500 N. Vickie Drive, OKC, OK 73117
 P.O. Box 10765, Midwest City, OK 73140
 405.418.4741 Fax: 405.418.4743

ITEM #	DESCRIPTION	UNIT	QUANTITY	UNIT PRICE	TOTAL PRICE
PCO-001					
PCO 1.1	1.5" AGGREGATE BASE TYPE A	TON	250.00	\$ 124.02	\$ 31,005.00
Total					\$ 31,005.00

NOTES:	
1	1.5" Aggregate base includes the material itself, placement, and processing to required specifications.
2	
3	
4	

PREPARED BY:	DATE:
Tim Lunday, President, TLunday@ellsworthinc.com	10/11/2024

ACCEPTED BY:	DATE:

Change Order MEMO



To: Mustang Board of Education
CC: Charles Bradley, Superintendent

From: Dr. Jason Pittenger, assistant Superintendent, Operations 

Date: 10/08/24

Contract Vendor: CADE Construction **Time Frame:** _____

Discussion, motion and possible action to approve the potential change order with the Construction Manager at-Risk:

New Elem #9 C/O #25 Fur out for saferoom conduit

PCO #25 includes all material, labor and equipment to fur out the west wall of spec ed 320 and the west mezzanine wall to encompass conduit that was unable to be ran in the tilt walls. The Cherokee Painting quote only includes tape and bed at the fur outs as they already had painting the concrete walls at these areas.

Contingency will be used in the amount of \$3,535.00

CADE Construction
701 W Sheridan Ave Suite 108
Oklahoma City, Oklahoma 73102
Phone: +14054106072

Project: 23-04 - Elementary #9
4800 S. Sara Road
Oklahoma City, Oklahoma 73064

Prime Contract Potential Change Order #025: Fur Out for Saferoom Conduit

TO:	Mustang Public Schools 909 S. Mustang Road Mustang, Oklahoma 73064	FROM:	CADE Construction 701 W. Sheridan Avenue Suite 108 Oklahoma City, Oklahoma 73102
PCO NUMBER/REVISION:	025 / 0	CONTRACT:	23-04 - Elementary #09
REQUEST RECEIVED FROM:		CREATED BY:	Blake Burden (CADE Construction)
STATUS:	Approved	CREATED DATE:	10/18/2024
REFERENCE:	Attached CO	PRIME CONTRACT CHANGE ORDER:	None
FIELD CHANGE:	No		
LOCATION:		ACCOUNTING METHOD:	Amount Based
SCHEDULE IMPACT:	0 days	PAID IN FULL:	No
EXECUTED:	No	SIGNED CHANGE ORDER RECEIVED DATE:	
		TOTAL AMOUNT:	\$0.00

POTENTIAL CHANGE ORDER TITLE: Fur Out for Saferoom Conduit

CHANGE REASON: Design Development

POTENTIAL CHANGE ORDER DESCRIPTION: *(The Contract Is Changed As Follows)*

PCO #25 - Arrow & Cherokee Painting - Fur out for Saferoom Conduit - \$3,535.00

PCO #25 includes all material, labor, and equipment to fur out the west wall of spec ed 320 and the west mezzanine wall to encompass conduit that was unable to be ran in the tilt walls. The Cherokee Painting quote only includes tape and bed at the fur outs as they already had painting the concrete walls at these locations.

ATTACHMENTS:

[Cherokee Painting - Safe Room Fur Out.pdf](#) , [Arrow - SPEC ED 320 & West Mezz Wall Furring.pdf](#)

#	Budget Code	Description	Amount
1	09-100-S.O Gypsum Board Assemblies & Ceiling Systems - Arrow	Arrow - Fur Out for Saferoom Conduit - Spec Ed 320	\$2,515.00
2	09-102-S.O Painting - Cherokee Painting	Cherokee - Tape/Bed Fur Out	\$600.00
3	01-103-L.O Project Manager	Staff Cost	\$420.00
4	01-040-O.O Contingency.Other	Utilize Contingency	\$(3,535.00)
Grand Total:			\$0.00

Heath Tate (MA+ Architecture)
4000 N. Classen Boulevard Suite 100N
Oklahoma City, Oklahoma 73118

Mustang Public Schools
909 S. Mustang Road
Mustang, Oklahoma 73064

CADE Construction
701 W. Sheridan Avenue Suite 108
Oklahoma City, Oklahoma 73102

 10-24-2024
SIGNATURE DATE

SIGNATURE DATE

 10/24/24
SIGNATURE DATE

Project: C 2411 - Mustang PS - ES #9

1. Change Order Title: <u>Spec Ed 320 & West Mezz Wall Furring</u>	2. Number	<u>COR 003</u>
3. Change Order Requested By: <u>Caleb Manning</u>	3. Date	<u>10.4.24</u>
5. Owner/Architect/Engineer Change Order Request Number		<u>CO 3</u>
6. Material		<u>\$ 985.21</u>
7. Equipment		
	8. Material and Equipment Subtotal	<u>\$ 985.21</u>
	9. Sales Tax	<u>0.0%</u> <u>\$ -</u>
10. Labor	<u>24</u> Manhours @ <u>\$ 34.00</u> /Hour	<u>\$ 816.00</u>
11. PM/Estimating	<u>1</u> Manhours @ <u>\$ 45.00</u> /Hour	<u>\$ 45.00</u>
12. Labor Insurance and Taxes	<u>30%</u>	<u>\$ 258.30</u>
13. Small Tools	<u>5%</u> of Labor	<u>\$ 40.80</u>
14. Out of Town Expenses	<u>0%</u> of Labor	<u>\$ -</u>
	15. Labor Sub-Total	<u>\$ 1,160.10</u>
16. Equipment Rental		
Scissor Lift	<u> </u> Hours @ <u>3.00</u> /Hour	<u>\$ -</u>
SkyTrack	<u> </u> Hours @ <u>30.00</u> /Hour	<u>\$ -</u>
Hoisting	<u> </u> Hours @ <u>125.00</u> /Hour	<u>\$ -</u>
Scaffold	<u> </u> Hours @ <u>20.00</u> /Hour	<u>\$ -</u>
	17. Equipment Rental Sub-Total	<u>\$ -</u>
18. Indirect Costs		
	19. Change Order Sub-Total Costs	<u>\$ 2,145.31</u>
	20. Overhead	<u>10%</u> <u>\$ 214.53</u>
	21. Sub-Total	<u>\$ 2,359.84</u>
	22. Profit	<u>5%</u> <u>\$ 117.99</u>
	23. (DEDUCTS)	
	24. Sub-Total	<u>\$ 2,477.83</u>
	25. Add'l Insurance Premiums	
	26. Bond Premium	<u>1.5%</u> <u>\$ 37.17</u>
	27. Total Change Order Cost	<u>\$ 2,515.00</u>
28. Additional Calendar Days Required	<u>1.5</u>	

29. Description of Additional Work

Spec Ed 320 and West Mezz Wall. Electrical chase furring needed, per CADE. This change includes framing and drywall extended to the deck, insulation excluded.

Submitted By: Caleb Manning

Title: Project Manager - OKC DIV

Cherokee Painting, LLC.

8833 SE 29th St.

Midwest City, OK 73110

Cell # 405-250-2560 Office # 405-610-7620

E-mail jrosser@cherokeepainting.com

October 2, 2024

REQUEST FOR CHANGE ORDER

Attn: Blake Burden - Cade
From: Joe Rosser
Subj: MPS Elem No. 9
Re: Spec Ed 320 and West Mezz Wall/ASI-019

This proposal, if accepted, shall be made a part of any contract entered into, either by attachment or direct incorporation. Pricing is offered per plans or as noted below. Any of the following exclusions may be waived in this proposal, if either, specific pricing is provided or if an item is directly waived in our proposal. If you are unsure of any of the items listed below, please call our office.

Cherokee Painting proposes to furnish the labor, material, equipment and necessary equipment to complete the above-mentioned project with the following scope.

1. Provide and install additional Tape and Bed on the new furred walls indicated on plans.

TOTAL

\$ 600.00

If you have any questions please don't hesitate to contact me.



Joe Rosser
Project Manager



Change Order MEMO



To: Mustang Board of Education

CC: Charles Bradley, Superintendent

From: Dr. Jason Pittenger, assistant Superintendent, Operations



Date: 10/08/24

Contract Vendor: Timberlake Construction **Time Frame:** _____

Discussion, motion and possible action to approve the potential change order with the Construction Manager at-Risk:

HS Expansion C/O #7 Contingency is used for the sanitary sewer line repair

MPS contingency will be used for sanitary sewer line repair in the amount of \$6,618.18

Timberlake Construction Co., Inc.
7613 N Classen Blvd
Oklahoma City, Oklahoma 73116
Phone: (405) 840-2521
Fax: (405) 840-5469

Project: 24-12 - Mustang HS Expansion
801 S Snyder
Mustang, Oklahoma 73099

Prime Contract Potential Change Order #007: CO #3 Contingency Draw Down

TO:	Mustang Public Schools 909 S Mustang Rd Mustang Oklahoma, 73064	FROM:	Timberlake Construction Co., Inc. 7613 N Classen Blvd Oklahoma City Oklahoma, 73116
PCO NUMBER/REVISION:	007 / 0	CONTRACT:	24-12 - Mustang HS Expansion
REQUEST RECEIVED FROM:		CREATED BY:	Jay Crawford (Timberlake Construction Co., Inc.)
STATUS:	Pending - In Review	CREATED DATE:	9/20 /2024
REFERENCE:		PRIME CONTRACT CHANGE ORDER:	None
FIELD CHANGE:	No		
LOCATION:		ACCOUNTING METHOD:	Amount Based
SCHEDULE IMPACT:		PAID IN FULL:	No
		TOTAL AMOUNT:	(\$6,618.18)

POTENTIAL CHANGE ORDER TITLE: CO #3 Contingency Draw Down

CHANGE REASON: Allowance

POTENTIAL CHANGE ORDER DESCRIPTION: *(The Contract Is Changed As Follows)*

CE #007 - CO #3 Contingency Draw Down
PCO #06 Sanitary Line Repair - \$6,618.18

ATTACHMENTS:

#	Cost Code	Description	Type	Amount
1	007-395 - Owner Contingency	CO #3 Contingency Draw Down	General	(\$6,618.18)
Subtotal:				(\$6,618.18)
Grand Total:				(\$6,618.18)

Mustang Public Schools
909 S Mustang Rd
Mustang, Oklahoma 73064

MA+ Architecture
4000 N Classen BlvdSte 100N
Oklahoma City, Oklahoma 73118

Timberlake Construction Co., Inc.
Oklahoma City
Oklahoma, United States 73116

SIGNATURE

DATE

SIGNATURE

DATE

SIGNATURE

DATE

INVOICE

Goforth Plumbing and Mechanical, LLC
 16818 SE 27th Street
 Choctaw, OK 73020
 Phone: (405) 390-1916

INVOICE DATE: 9/17/24
 INVOICE NUMBER: 18693

Oklahoma License #
 Plumbing 4172
 Mechanical 8311

SOLD TO: Timberlake Construction
 P.O. Box 18297
 Oklahoma City, OK 73154

JOB NUMBER	YOUR PO NUMBER	PAYMENT TERMS	DUE DATE
24-1437		Net 30 days	10/17/24

QUANTITY	ITEM NUMBER	DESCRIPTION	UNIT PRICE	EXTENSION
2.00	JHRS	Journeyman Hours	110.00	220.00
2.00	APPHRS	Apprentice Hours	90.00	180.00
1.00	MAT	Job Materials	215.00	215.00
1.00	SUB	Sub-Contractors Labor	5,530.00	5,530.00
		Mustang HS Gym Sanitary Repairs (Per Kaylon Bates)		

Thank you for your business!

SUBTOTAL:	6,145.00
SHIPPING:	0.00
TAX:	0.00
OTHER:	0.00
TOTAL	6,145.00

Change Order MEMO



To: Mustang Board of Education
CC: Charles Bradley, Superintendent

From: Dr. Jason Pittenger, assistant Superintendent, Operations 

Date: 10/08/24

Contract Vendor: Timberlake Construction **Time Frame:** _____

Discussion, motion and possible action to approve the potential change order with the Construction Manager at-Risk:

HS Expansion C/O #8 Demo Contingency Return

Unused project contingency returned to MPS (\$11,919.82)

Timberlake Construction Co., Inc.
7613 N Classen Blvd
Oklahoma City, Oklahoma 73116
Phone: (405) 840-2521
Fax: (405) 840-5469

Project: 24-12 - Mustang HS Expansion
801 S Snyder
Mustang, Oklahoma 73099

Prime Contract Potential Change Order #008: MPS HS Expan (Demo) Cont Return

TO:	Mustang Public Schools 909 S Mustang Rd Mustang Oklahoma, 73064	FROM:	Timberlake Construction Co., Inc. 7613 N Classen Blvd Oklahoma City Oklahoma, 73116
PCO NUMBER/REVISION:	008 / 0	CONTRACT:	24-12 - Mustang HS Expansion
REQUEST RECEIVED FROM:		CREATED BY:	Jay Crawford (Timberlake Construction Co., Inc.)
STATUS:	Pending - In Review	CREATED DATE:	10/14 /2024
REFERENCE:		PRIME CONTRACT CHANGE ORDER:	None
FIELD CHANGE:	No		
LOCATION:		ACCOUNTING METHOD:	Amount Based
SCHEDULE IMPACT:		PAID IN FULL:	No
		TOTAL AMOUNT:	(\$11,919.82)

POTENTIAL CHANGE ORDER TITLE: MPS HS Expan (Demo) Cont Return

CHANGE REASON: Allowance

POTENTIAL CHANGE ORDER DESCRIPTION: *(The Contract Is Changed As Follows)*

CE #008 - MPS HS Expan (Demo) Contingency Return

Unused project contingency return. Contingency was added below the fee line as a lump sum to the project, so fee return doesn't apply.

ATTACHMENTS:

#	Cost Code	Description	Type	Amount
1	007-395 - Owner Contingency	Contingency Return	General	(\$11,919.82)
Subtotal:				(\$11,919.82)
Grand Total:				(\$11,919.82)

Mustang Public Schools
909 S Mustang Rd
Mustang, Oklahoma 73064

MA+ Architecture
4000 N Classen Blvd Ste 100N
Oklahoma City, Oklahoma 73118

Timberlake Construction Co., Inc.
Oklahoma City
Oklahoma, United States 73116

SIGNATURE

DATE

SIGNATURE

DATE

SIGNATURE

DATE

Description	TCl Code	Date	PCO Number	CO #	Original Value	Costs Used	Costs Remaining
Contingency	007-395G				25,000.00		
1. Cut off water and sewer 5' from blds.		05.07.24	3	2		6,462.00	
2. Sanitary Line Repairs		09.20.24	6	3		6,618.18	
							11,919.82
Totals					25,000.00	13,080.18	11,919.82

Change Order MEMO



To: Mustang Board of Education

CC: Charles Bradley, Superintendent

From: Dr. Jason Pittenger, assistant Superintendent, Operations

A blue handwritten signature, likely of Dr. Jason Pittenger, written over the 'From:' line.

Date: 10/08/24

Contract Vendor: Timberlake Construction **Time Frame:** _____

Discussion, motion and possible action to approve the potential change order with the Construction Manager at-Risk:

Softball Hitting Facility C/O #20 Add S fixture to corr 116

MPS decided to add an S fixture to the corridor 116 in the amount of \$771.13

Timberlake Construction Co., Inc.
7613 N Classen Blvd
Oklahoma City, Oklahoma 73116
Phone: (405) 840-2521
Fax: (405) 840-5469

Project: 23-20 - Mustang Softball Batting Facility
421 W Dowden
Mustang, Oklahoma 73064

Prime Contract Potential Change Order #020: Add S Fixture to Cor 116

TO:	Mustang Public Schools 909 S Mustang Rd Mustang Oklahoma, 73064	FROM:	Timberlake Construction Co., Inc. 7613 N Classen Blvd Oklahoma City Oklahoma, 73116
PCO NUMBER/REVISION:	020 / 0	CONTRACT:	23-20 - Mustang Softball Field
REQUEST RECEIVED FROM:		CREATED BY:	Jay Crawford (Timberlake Construction Co., Inc.)
STATUS:	Pending - In Review	CREATED DATE:	10/25 /2024
REFERENCE:		PRIME CONTRACT CHANGE ORDER:	None
FIELD CHANGE:	No	ACCOUNTING METHOD:	Amount Based
LOCATION:		PAID IN FULL:	No
SCHEDULE IMPACT:		TOTAL AMOUNT:	\$771.13

POTENTIAL CHANGE ORDER TITLE: Add S Fixture to Cor 116

CHANGE REASON: Allowance

POTENTIAL CHANGE ORDER DESCRIPTION: *(The Contract Is Changed As Follows)*

CE #020 - Add S Fixture to Corridor 116

The owner decided to add an S fixture to the corridor 116.

ATTACHMENTS:

#	Cost Code	Description	Type	Amount
1	260-500 - Electrical	Add S Fixture to Corridor 116	Subcontract	\$ 716.00
Subtotal:				\$716.00
Insurance : 0.28% Applies to all line item types.				\$ 2.00
Bonds: 1.50% Applies to all line item types.				\$ 10.74
Safety: 0.32% Applies to all line item types.				\$ 2.29
Shop Support: 0.30% Applies to all line item types.				\$ 2.15
Cleaning General: 0.30% Applies to all line item types.				\$ 2.15
Fee: 5.00% Applies to all line item types.				\$ 35.80
Grand Total:				\$771.13

Mustang Public Schools
909 S Mustang Rd
Mustang, Oklahoma 73064

MA+ Architecture
4000 N Classen Blvd Ste 100N
Oklahoma City, Oklahoma 73118

Timberlake Construction Co., Inc.
Oklahoma City
Oklahoma, United States 73116

SIGNATURE

DATE

SIGNATURE

DATE

SIGNATURE

DATE



4712 SW 20TH ST
OKLAHOMA CITY OK 73128
405.604.5479
OK LICENSES # 63254

Mustang Softball Batting Facility

10-16-2024

Quote Number 2115-004

Scope: Pricing to add a "S" fixture mounted to the red wall at the south entry of corridor 116.

Material -	\$100.00
Light -	\$112.00
Labor -	\$380.00
Overhead -	\$59.00
Markup -	\$65.00

TOTAL \$716.00

Vice President

Ben Griffith

Encumbrance Register

Options: Year: 2024-2025, Date Range: 10/10/2024 - 11/7/2024, PO Range: 1057 - 5000, Fund(s): 11-General

Fund	PO No	Date	Vendor No	Vendor	Description	Amount
11	1057	10/11/2024	10027	Charrick Associates	026-Blanket Spare Keys	500.00
				026 Blanket for blank keys	11-026-2740-612-000-0000-000-050	500.00
11	1058	10/11/2024	67956	Howard industries Inc	002 150 Smart Board Bulbs	216.00
				Quote# MP 1447938.00Epson ELPLP80 - Projector lamps	11-002-1000-653-100-0000-000-150	216.00
11	1059	10/11/2024	17260	VIDEO REALITY	002 - Sound System for Cafeteria	7,500.00
				002 - Small 7 RU rack, 6 input mixer amplifier, rack mounted power unit, dual wireless handheld microphone system, wall plate volume controller, 6 pendant speakersQuote #013568	11-002-2410-732-900-0000-000-105	7,500.00
11	1060	10/11/2024	68493	Larry W. Oakley	066 District Piano Tuning	240.00
				066 District Piano Tuning	11-066-1000-439-100-0000-000-050	240.00
11	1061	10/11/2024	14462	Amazon Capital Services Inc.	002 Playground equipment	6,008.61
				002 Playground equipmentGaga pit, flooring, tetherball	11-002-2410-619-900-0000-000-135	6,008.61
11	1062	10/11/2024	63566	REV Robotics LLC	412 R Swan Classroom Materials	275.00
				412 Rhoda Swan Classroom Materials - Battery Chargers and Hex Shafts	11-412-1000-681-315-8700-000-510	275.00
11	1063	10/11/2024	14462	Amazon Capital Services Inc.	621 Physical Therapy Supplies	600.00
				621 Physical Therapy Supplies	11-621-2170-619-239-0000-000-050	19.48
					11-621-2170-619-239-0000-000-050	580.52
11	1064	10/11/2024	17183	NO TEARS LEARNING INC	621 OT Supplies	200.00
				621 OT Supplies	11-621-2135-658-239-0000-000-115	131.10
					11-621-2135-658-239-0000-000-115	21.15
					11-621-2135-658-239-0000-000-115	47.75
11	1065	10/11/2024	14462	Amazon Capital Services Inc.	621 Speech Supplies	500.00
				621 Speech Supplies	11-621-2152-614-239-0000-000-050	22.98
					11-621-2152-614-239-0000-000-050	477.02
11	1066	10/15/2024	14462	Amazon Capital Services Inc.	066 MBI Art Class Supplies	350.00
				066 MBI Art Class Items - sharpies, cardstock, tape, paint, etc	11-066-1000-611-100-1173-000-160	60.00
					11-066-1000-619-100-1173-000-160	255.02
					11-066-1000-619-100-1173-000-160	34.98
11	1067	10/15/2024	14462	Amazon Capital Services Inc.	066 Valley Music Class Items	350.00
				066 Classroom Items for Valley Music Class. Paper, pipe cleaners, envelopes etc	11-066-1000-611-100-1183-000-120	100.00
					11-066-1000-619-100-1183-000-120	250.00
11	1068	10/15/2024	11059	Blick Art Materials, LLC	066 Creek Art Supplies	230.10
				066 Art supplies for Creek	11-066-1000-611-100-1173-000-125	210.66
					11-066-1000-619-100-1173-000-125	19.44
11	1069	10/15/2024	61446	OKLAHOMA SCHOOLS INSURANCE GROUP	016-Deductible	1,000.00
				016-Insurance Deductible for Bus Accident dated 10.10.24	11-016-2720-521-000-0000-000-050	1,000.00
11	1070	10/15/2024	61446	OKLAHOMA SCHOOLS INSURANCE GROUP	016-Deductible	1,000.00
				016-Deductible for White Fleet Accident DOL 10.10.24	11-016-2720-521-000-0000-000-050	1,000.00
11	1071	10/15/2024	14462	Amazon Capital Services Inc.	412 Classroom Supplies J Harrison	350.00
				412 Jaqueline Harrison Classroom Supplies such as sealer, foam brushes, magnetic sign holders etc.	11-412-1000-681-314-8400-000-705	134.27
					11-412-1000-681-314-8400-000-705	225.73

Encumbrance Register

Options: Year: 2024-2025, Date Range: 10/10/2024 - 11/7/2024, PO Range: 1057 - 5000, Fund(s): 11-General

Fund	PO No	Date	Vendor No	Vendor	Description	Amount
11	1072	10/15/2024	68956	Board of Regents OUHSC	615 School-Based Autism Assessment Team Course Reg	1,100.00
			11-615-2573-860-239-0000-000-050		615 Registration for School-Based Autism Assessment Team Course2 Team @ \$550 Multi-Day & MultilocationTeam 1: Tami Lucas, Kristin Evans, Erin Tobiason, and Jaimie KuykendallTeam 2: Stacy McKinney, Kayla Ward, Amanda Peters, Gabriela Lopez	1,100.00
11	1073	10/15/2024	85788	Kayla Darlene Ward	615 School-Based Autism Assess Team Course Travel	300.00
			11-615-2573-580-239-0000-000-050		615 Travel for School-Based Autism Assessment Team CourseDay 1: 10/25/24 In-Person OKCDay 2: 12/13/24 VirtualDay 3: 03/05/25 In-Person OKCDay 4: 03/27/25 In-Person OKCDay 5: 04/11/25 Virtual	300.00
11	1074	10/15/2024	85398	Kristin Elizabeth Evans	615 School-Based Autism Assess Team Course Travel	300.00
			11-615-2573-580-239-0000-000-050		615 Travel for School-Based Autism Assessment Team CourseDay 1: 10/25/24 In-Person OKCDay 2: 12/13/24 VirtualDay 3: 03/05/25 In-Person OKCDay 4: 03/27/25 In-Person OKCDay 5: 04/11/25 Virtual	300.00
11	1075	10/15/2024	85106	Erin Maureen Tobiason	615 School-Based Autism Assess Team Course Travel	300.00
			11-615-2213-580-239-0000-000-115		615 Travel for School-Based Autism Assessment Team CourseDay 1: 10/25/24 In-Person OKCDay 2: 12/13/24 VirtualDay 3: 03/05/25 In-Person OKCDay 4: 03/27/25 In-Person OKCDay 5: 04/11/25 Virtual	300.00
11	1076	10/15/2024	14578	SYNERGY DATA COM	002- Cables for Smartboards/Boatman	281.44
			11-002-1000-653-900-0000-000-705		002- HSCE1 Arlington 1g Cable Entrance Plate White	10.12
			11-002-1000-653-900-0000-000-705		255050X 1.0 Vanco 50ft High Speed HDMI Cable, Bulk	129.86
			11-002-1000-653-900-0000-000-705		40416 1.0 C2G 50Ft 3.5MM M/M Audio Cable	27.10
			11-002-1000-653-900-0000-000-705		TSR2I-8A ST 1.0 Tyton 1-1/4 Plastic Latch Duct Ivory 8ft	55.76
			11-002-1000-653-900-0000-000-705		179300 1.0 Ic Usb over Cat5e 60m/196ft	42.24
			11-002-1000-653-900-0000-000-705		TSRI-JB1 1.0 Tyton 1g Surface Mount Box Ivory 1.25 D	16.36
11	1077	10/15/2024	14462	Amazon Capital Services Inc.	066 Creek Art Supplies	86.08
			11-066-1000-619-100-1173-000-125		066 United Novelty Super Bright Fluorescent 43ML Mini Bingo Daubers set of 9	86.08
11	1078	10/15/2024	14462	Amazon Capital Services Inc.	412 Classroom Supplies (V Bacca)	1,738.88
			11-412-1000-681-315-8700-000-160		412 Vanessa Baca Classroom Supplies including filament, microbit robotics kits, coding robots etc.	25.99
			11-412-1000-681-315-8700-000-160			1,712.89
11	1079	10/21/2024	66642	OKLAHOMA KENWORTH INC	026 blanket bus parts and repairs	25,000.00
			11-026-2740-612-000-0000-000-050		026 blanket Bus parts and repairs	25,000.00

Encumbrance Register

Options: Year: 2024-2025, Date Range: 10/10/2024 - 11/7/2024, PO Range: 1057 - 5000, Fund(s): 11-General

Fund	PO No	Date	Vendor No	Vendor	Description	Amount
11	1080	10/21/2024	67046	COMMERCE BANK	026 Hotel TSD Conference 10/21/2024	1,000.00 1,000.00
				026 Hotel Transporting students with disabilities Albany McClure and Richelle Miller110724-111224Frisco, Texas 11-026-2573-582-000-0000-000-050		
11	1081	10/21/2024	67046	COMMERCE BANK	026 TSD Registration 10/21/2024	1,300.00 1,300.00
				026 Registration for Transporting student with disabilities conferenceAlbany McClure and Richelle MillerNov 7-12, 2024 at Frisco, Texas 11-026-2573-582-000-0000-000-050		
11	1082	10/21/2024	84020	Albany Kay McClure	026 Per diem and reimbursements 10/21/2024	500.00 500.00
				026 Albany McClure per diem and reimbursements of travel expensesTSD conference Nov 7-12, 2024 at Frisco, Texas 11-026-2573-582-000-0000-000-050		
11	1083	10/21/2024	87522	Jana Richelle Miller	026 per diem and reimbursements for travel 10/21/2024	500.00 500.00
				026 Jana Richelle Miller per diem and reimbursement for travel expensesTSD ConferenceNov 7-12, 2024 at Frisco, Texas 11-026-2573-582-000-0000-000-050		
11	1084	10/21/2024	61446	OKLAHOMA SCHOOLS INSURANCE GROUP	016-Deductible 10/21/2024	1,000.00 1,000.00
				016-Insurance Deductible for Bus accident DOL 10.14.24 11-016-2720-521-000-0000-000-050		
11	1085	10/21/2024	14462	Amazon Capital Services Inc.	REPAIR AND REPLACEMENT PARTS 10/21/2024	2,000.00 2,000.00
				REPAIR AND REPLACEMENT PARTS 11-023-3140-618-700-0000-000-050		
11	1086	10/21/2024	99999	MUSTANG PUBLIC SCHOOLS	023 - UNIFORM REIMBURSEMENTS 10/21/2024	13,000.00 13,000.00
				UNIFORM REIMBURSEMENTS 11-023-3140-657-700-0000-000-050		
11	1087	10/21/2024	11059	Blick Art Materials, LLC	066 AP Art History Class Items 10/21/2024	300.00 300.00
				066 AP Art History Class Items 11-066-1000-619-100-2816-000-705		
11	1088	10/21/2024	14462	Amazon Capital Services Inc.	066 MHS AP Art History Class 10/21/2024	41.53 41.53
				Dixie Basic 8.5" Light-Weight Paper Plates by GP PRO (Georgia-Pacific), White, DBP09W, 500 Count (125 Plates Per Pack, 4 Packs Per Case) 11-066-1000-619-100-2740-000-705		
11	1089	10/21/2024	67046	COMMERCE BANK	hotel for NASRO conference 10/21/2024	1,200.00 1,200.00
				hotel for 2025 NASRO conference- July 06-11, 2025; 240 per night= 1200.00 11-024-2660-580-000-0000-000-050		
11	1090	10/21/2024	14462	Amazon Capital Services Inc.	511 Bronco Family Night (10/28/24) 10/21/2024	2,500.00 1,434.06
				511 Bronco Family Night Learning Games and Giveaways 11-511-2194-619-429-0000-000-050 11-511-2194-619-429-0000-000-050		1,065.94
11	1091	10/21/2024	14462	Amazon Capital Services Inc.	002 - Books 10/21/2024	60.00 60.00
				Ramae CollinsThe Courage to Teach: Exploring the Inner Landscape of a Teacher's Life Book 11-002-2410-641-000-0000-000-505		
11	1092	10/21/2024	14462	Amazon Capital Services Inc.	002 - Blanket PO Office Supplies 10/21/2024	1,000.00 1,000.00
				Shiella VardemanBlanket PO for Office Supplies 11-002-2340-619-000-0000-000-505		

Encumbrance Register

Options: Year: 2024-2025, Date Range: 10/10/2024 - 11/7/2024, PO Range: 1057 - 5000, Fund(s): 11-General

Fund	PO No	Date	Vendor No	Vendor	Description	Amount
11	1093	10/21/2024	21757	UNIVERSITY OF OKLAHOMA - K20 CENTER	003- ILI Registration for Alicia Layne 11/21/24	200.00
			003- PD MHSRegistration for K20 Centers Innovative Learning Institute in Norman, OK11/21/24Alicia Layne	11-003-2213-860-900-0000-000-705	10/21/2024	200.00
11	1094	10/21/2024	61450	FULL SPECTRUM LASER LLC	421 - STEM B Coffman Classroom Materials	4,500.00
			421 STEM: Brett Coffman Muse 3D Autofocus 20"x12" Desktop CO2 Laser	11-421-1000-681-332-8700-000-505	10/21/2024	4,500.00
11	1095	10/21/2024	12994	PITSCO EDUCATION, LLC	421 -STEM B Coffman Classroom Materials	3,500.00
			421 STEM: Brett Coffman Echo Drone 10pk	11-421-1000-681-332-8700-000-505	10/21/2024	3,500.00
11	1096	10/23/2024	14569	Staples, Inc.	002 BULLETIN BOARD PAPER ROLLS	500.00
			36" W X 1000' L PAPER ROLLS (RED, WHITE, BLACK, BLUE)	11-002-1000-611-900-0000-000-510	10/23/2024	500.00
11	1097	10/23/2024	68955	Muscogee Creek Nation	025-Hotel stay for OKSTE Conference	516.22
			Hotel stay for OKSTE Conference for Geromy SchrickNov 5-8River Spirit Resort	11-025-2573-580-000-0000-000-050	10/23/2024	516.22
11	1098	10/23/2024	68493	Larry W. Oakley	066 Piano String Repair	60.00
			066 Piano String Repair	11-066-1000-439-100-0000-000-050	10/23/2024	60.00
11	1099	10/23/2024	67046	COMMERCE BANK	541 C Tobler Registration Fee (Atixa VI Conf)	1,400.00
			541 - Chris Tobler Registration to Atixa Title VI Training Oct. 25-26, 2024; Philadelphia, PA	11-541-2213-860-000-0000-000-050	10/23/2024	1,400.00
11	1100	10/23/2024	86045	Gary Wayne Knowles	412 BLANKET Est. Travel Exp. G Knowles	500.00
			412 BLANKET Ext. Travel Exp. for Gary Knowles to attend: NASA OKSG PD SIA 10/25-27, Speedfest 11/16, FAA 12/4	11-412-2213-580-315-8700-000-705	10/23/2024	500.00
11	1101	10/24/2024	14231	OKLAHOMA TSA	412 Registration TSA Fall Lead Conf. 11/05/24	25.00
			412 Gary Knowles Registration to TSA FALL Leadership Conference, Norman, OK 11/05/24	11-412-2213-860-315-8700-000-705	10/24/2024	25.00
11	1102	10/24/2024	14462	Amazon Capital Services Inc.	572 K Dunn EL Classroom Materials	150.00
			572 EL - Kristina Dunn Classroom Materials such as Learning Games	11-572-1000-681-410-1310-000-705	10/24/2024	79.18
				11-572-1000-681-410-1310-000-705	10/24/2024	70.82
11	1103	10/24/2024	68945	Robert Hahn	066 MHS Acting/Vocal Fee	800.00
			066 MHS Theatre Acting Workshop for students and Theatre Teachers (Laban Technique)	11-066-1000-811-100-4000-000-705	10/24/2024	800.00
11	1104	10/24/2024	68962	BRAIN AND SENSORY SUPPORT CO.	615 Reg Brain & Sensory Foundations 1st Level	990.00
			615 Registration for Amy Farris & Sybil GeorgeBrain & Sensory Foundations 1st Level (Part 1)Online 11/01/24 - 07/31/25	11-615-2573-860-239-0000-000-050	10/24/2024	990.00

Encumbrance Register

Options: Year: 2024-2025, Date Range: 10/10/2024 - 11/7/2024, PO Range: 1057 - 5000, Fund(s): 11-General

Fund	PO No	Date	Vendor No	Vendor	Description	Amount	
11	1105	10/24/2024	14462	Amazon Capital Services Inc.	002 FS playground equipment	369.95	
				002 Outdoor dome for FS and DD Playground	11-002-2199-651-000-0000-000-135	10/24/2024	369.95
11	1106	10/24/2024	14462	Amazon Capital Services Inc.	002-two way walkies for safety in classrooms	1,710.00	
				two way walkie talkies for safety in classrooms and communication with the office.	11-002-2670-619-900-0000-000-110	10/24/2024	1,710.00
11	1107	10/24/2024	67296	Follett Content Solutions, LLC	006 Media allocation - Follett	1,787.63	
				Follett Book order	11-006-2220-641-000-0000-000-120	10/24/2024	1,124.68
					11-006-2220-641-000-0000-000-120	10/24/2024	662.95
11	1108	10/24/2024	14462	Amazon Capital Services Inc.	002- Whiteboards for B. Mathes	908.48	
				002- HS3 whiteboards for Brandon Mathes. Math class in B135	11-002-1000-619-100-0000-000-705	10/24/2024	750.00
				002- HSAdding additional whiteboard for B. Mathes	11-002-1000-619-900-0000-000-705	10/24/2024	158.48
11	1109	10/24/2024	14462	Amazon Capital Services Inc.	572- EL Intervention Supplies Katie Pruett	15.00	
				572- EL Intervention Supplies Katie Pruett such as charger for translation earbuds	11-572-1000-681-410-1310-000-115	10/24/2024	14.98
					11-572-1000-681-410-1310-000-115	10/24/2024	0.02
11	1110	10/24/2024	14462	Amazon Capital Services Inc.	412 B Carey Classroom Supplies	1,480.01	
				412 Bailey Carey Classroom Supplies such as film storage, video camera, ink cartridges, card stock etc.	11-412-1000-681-316-8100-000-705	10/24/2024	1,480.01
11	1111	10/24/2024	15147	LOWES CREDIT SERVICES	412 B Coffman Classroom Supplies	450.00	
				412 Brett Coffman project classroom supplies	11-412-1000-681-315-8700-000-505	10/24/2024	303.28
					11-412-1000-681-315-8700-000-505	10/24/2024	146.72
11	1112	10/24/2024	14462	Amazon Capital Services Inc.	412 J Ford Classroom Supplies	600.00	
				412 Jeremy Ford Classroom Supplies such as digital stopwatches, astrocam rocket camera, polyester thread etc.	11-412-1000-681-315-8700-000-525	10/24/2024	600.00
11	1113	10/24/2024	13963	CAPITAL ONE TRADE CREDIT	412 - BLANKET: C Matlock Classroom Supplies	2,000.00	
				412 Courtney Matlock Classroom Supplies	11-412-1000-681-314-8400-000-705	10/24/2024	2,000.00
11	1114	10/29/2024	14462	Amazon Capital Services Inc.	572 EL Classroom Supplies (A Mills)	150.00	
				572 EL Amanda Mills Classroom Supplies such as (10) Aceele USB Hub 3.0 Splitter with 4ft Extension Long Cable Cord for Chromebooks	11-572-1000-653-410-1310-000-150	10/29/2024	102.79
					11-572-1000-653-410-1310-000-150	10/29/2024	47.21
11	1115	10/29/2024	14462	Amazon Capital Services Inc.	002 - student supplies	225.29	
				002 - student school supplies	11-002-1000-619-800-0000-000-525	10/29/2024	225.29
11	1116	10/29/2024	12971	HERTZBERQ-NEW METHOD, INC.	11-06-Assorted Library books	2,197.50	
				Assorted Library BooksPurchased with General Funds	11-006-2199-641-900-0000-000-160	10/29/2024	2,197.50
11	1117	10/29/2024	12960	Betroid Enterprises, Inc.	066 Fall Festival Music for MCMS	315.00	
				066 Eneza Upendo - SA	11-066-1000-619-100-1183-000-525	10/29/2024	142.50
				It Feels New - SAB	11-066-1000-619-100-1183-000-525	10/29/2024	132.50
				Shipping	11-066-1000-619-100-1183-000-525	10/29/2024	40.00

Encumbrance Register

Options: Year: 2024-2025, Date Range: 10/10/2024 - 11/7/2024, PO Range: 1057 - 5000, Fund(s): 11-General

Fund	PO No	Date	Vendor No	Vendor	Description	Amount
11	1119	10/29/2024	22211	ARCHWAY MARKETING SERVICES	Increase for POs for additional shipping fees	2,665.60
					Increase for PO 33-5 & Invoice # 120374	510.00
					Increase for PO 33-8 & Invoice # 120380	986.00
					Increase for PO 33-9 & Invoice #120382	476.00
					Increase for PO 33-11 & Invoice #120386	95.20
					Increase for PO 33-10 & Invoice #120384	598.40
11	1120	10/29/2024	14462	Amazon Capital Services Inc.	412 K Owen Classroom Supplies	350.00
					412 Krista Owen Classroom Supplies such as screwdriver sets, modeling clay, neon dough etc.	350.00
11	1121	10/30/2024	66794	MOSYLE CORPORATION	025-Licensing for MacBook	12.75
					Mosyle Manager MDM and Mosyle AuthCharles Bradley	12.75
11	1122	10/31/2024	20361	NOAH'S PARK AND PLAYGROUNDS	041 Adaptive Swing Harness Replacement	150.00
					041 Adaptive Swing Harness Replacement	150.00
11	1123	10/31/2024	11059	Blick Art Materials, LLC	066 MHS Art Supplies K Starr	1,200.00
					066 MHS Art Class Items for K Starr	1,200.00
11	1124	10/31/2024	14446	WEST MUSIC	066 Creek Music Items	799.98
					066 SONOR BWG-B GLOCK;SOP;BWG;BAG	270.00
					BASIC BEAT BBRCB8 RESONATOR BELLS;8;C1-C2;MLTS	529.98
11	1125	10/31/2024	20811	THE COLLEGE BOARD	066 AP Exams for MHS Art History/Music Theory	1,650.00
					066 AP Exams for MHS AP Art History and AP Music Theory	1,650.00
11	1126	10/31/2024	99999	MUSTANG PUBLIC SCHOOLS	003-substitute coverage for observations	55.00
					1/2 day substitute 11/7/24--M. EdwardsM. England-substitute	55.00

Encumbrance Register

Options: Year: 2024-2025, Date Range: 10/10/2024 - 11/7/2024, PO Range: 1057 - 5000, Fund(s): 11-General

Fund	PO No	Date	Vendor No	Vendor	Description	Amount
11	1127	10/31/2024	14462	Amazon Capital Services Inc.	071 SREB Items for RAISE:OK at MMS	1,239.18
					EXPO Whiteboard / Dry Erase Board Liquid Cleaner MmcQFq, 22, Oz (2 Bottles)	45.60
					Magicfly Small White Board Grid Whiteboard Dry Erase Boards XY Axis Graph 9"x12", 16 Pack Mini Math Whiteboard Portable for Students Classroom Teachers School Supplies with 20 Pens and 16 Erasers	155.96
					SFAIH Fine Tip Dry Erase Markers - 144 Pack Black Whiteboard Erasable Markers Bulk for Kids Adults, Ideal for Classroom School Office Home Use on White Board, Non-Toxic Easy Clean	209.94
					Astrobrights Color Paper, 8.5" x 11", 24 lb/89 gsm, Sprinkle Assortment, 300 Sheets (94000) (Pack of 2)	32.76
					Marvel Titan Hero Series Action Figure Multipack, 6 Action Figures, 12 -Inch Toys, Inspired By Marvel Comics, For Kids Ages 4 And Up (Amazon Exclusive)	310.98
					Marbrasse 6 Tier Paper Organizer Letter Tray - Mesh Desk File Organizer with Handle, Paper Sorter Organizer for Letter/A4 Office File Folder Holder - Black	22.69
					Barbie Careers Doll & Accessories, Future Leader with Light Brown Hair Wearing Outfit with 2 Golden Bracelets & "B" Pin, Includes Future Leader Sticker for Kids	43.96
					Barbie Careers Fashion Doll & Accessory, Nurse Wearing Print Top, Pink Pants & White Shoes with Stethoscope	59.34
					Frestec 1.7 Cu.Ft Mini Fridge with Freezer,Mini Fridge for Bedroom,Small Refrigerator,Dorm Refrigerators with Freezer,Compact Refrigerator for Office,Apartment,Dorm,Bedroom (Black)	269.91
					Childcraft Construction Paper, 9 x 12 Inches, Assorted Colors, 500 Sheets - 1465886	28.04
					Shipping	60.00
11	1128	10/31/2024	12960	Betold Enterprises, Inc.	066 MCMS Fall Festival Music	150.00
					MCMS Autumn Leaves - SATB - Paris Rutherford	150.00
11	1129	11/01/2024	14462	Amazon Capital Services Inc.	003 Media Books	134.05
					003 Books MEDIA	134.05
11	1130	11/01/2024	13991	WESTCO COMPUTER & LAMINATOR	002 Laminating Film	672.00
					002 - Laminating Film	672.00

Encumbrance Register

Options: Year: 2024-2025, Date Range: 10/10/2024 - 11/7/2024, PO Range: 1057 - 5000, Fund(s): 11-General

Fund	PO No	Date	Vendor No	Vendor	Description	Amount	
11	1131	11/01/2024	14462	Amazon Capital Services Inc.	066 Valley Art Class Items	131.00	
				066 Crayola Air Dry Clay (5lbs), Natural White Modeling Clay for Kids, Sculpting Material, Bulk Craft Supplies for School Classrooms [Amazon Exclusive]	11-066-1000-619-100-1173-000-110	11/01/2024	81.00
				Mont Marte Discovery School Acrylic, Titanium White and Black, 1/2 Gallon (2 Liter). Ideal for Students and Artists. Excellent Coverage and Fast Drying. Pump Lid Included.	11-066-1000-619-100-1173-000-110	11/01/2024	50.00
11	1132	11/01/2024	14462	Amazon Capital Services Inc.	041 iPad Keyboard Case w/ Pen Holder	400.00	
				041 iPad Keyboard Case w/ Pen Holder x3Meg Corn, Stephanie Matthews, and Lori Naeher	11-041-2580-653-239-0000-000-050	11/01/2024	400.00
11	1133	11/01/2024	13119	REALLY GOOD STUFF	621 Tall Privacy Dividers for Desks	150.00	
				621 Tall Privacy Dividers for DesksTesting and Resource Center	11-621-1000-619-239-0000-000-705	11/01/2024	150.00
11	1134	11/01/2024	63314	REAL OT SOLUTIONS, INC.	621 OT Supplies	100.00	
				621 OT Supplies	11-621-2135-658-239-0000-000-125	11/01/2024	100.00
11	1135	11/01/2024	22211	ARCHWAY MARKETING SERVICES	333-6th Grade Math Books for Intermediate Schools	10,895.00	
				BIL OK2025 MATH GR6 PRACTICE AND TEST PREP WORKBOOK 6 YR- LARSON 1ST EDITION (K12, 2025 9798888039649/8888039643	11-333-1000-641-100-2200-000-140	11/01/2024	9,900.00
				SHIPPING	11-333-1000-641-100-2200-000-160	11/01/2024	495.00
				ADDITIONAL SHIPPING	11-333-1000-641-100-2200-000-140	11/01/2024	500.00
11	1136	11/01/2024	64786	GENERATION GENIUS, INC	071 / 002 - Generation Genius Online Subscription	1,795.00	
				071 - Generation Genius Subscription	11-071-1000-681-034-2250-000-140	11/01/2024	1,300.00
				002 - Generation Genius online subscription	11-071-1000-681-034-2250-000-140	11/01/2024	495.00
11	1137	11/01/2024	23066	AndyMark Inc.	469 Lottery Grant Classroom Materials (J Holman)	201.75	
				469 Lottery Grant Classroom Materials for Jessica Holman. Brushless Powerpole Kit/3 ea \$21.00 Item Total \$63.00FTC Power Switch with Bracket/5 ea \$15.25 Item Total \$76.25PWM Male Connectors (25 Housings, 100 Pins)/1 ea \$26.00 Item Total \$26.00	11-469-1000-681-315-8700-000-705	11/01/2024	201.75
11	1138	11/01/2024	62575	KALEN LAKE	469 Lottery Grant Classroom Materials (J Holman)	1,021.00	
				469 Lottery Grant: Jessica Holman Classroom Materials such as control sensor system and cables	11-469-1000-681-315-8700-000-705	11/01/2024	1,021.00
11	1139	11/01/2024	68942	Douglas Harnish	054 - GATE Private Instrument Lessons MMS	500.00	
				054 GATE Private Instrument Lessons MMS	11-054-1000-322-251-0000-000-505	11/01/2024	500.00

Encumbrance Register

Options: Year: 2024-2025, Date Range: 10/10/2024 - 11/7/2024, PO Range: 1057 - 5000, Fund(s): 11-General

Fund	PO No	Date	Vendor No	Vendor	Description	Amount
11	1140	11/01/2024	68564	Jacob Merrill	054 GATE Private Instrument Lessons - MMS	500.00
			054 GATE Private Instrument Lessons - MMS	11-054-1000-322-251-0000-000-505	11/01/2024	500.00
11	1141	11/01/2024	64814	REBECCA LITTLE	054 GATE Private Instrument Lessons - MMS	500.00
			054 GATE Private Instrument Lessons - MMS	11-054-1000-322-251-0000-000-505	11/01/2024	500.00
11	1142	11/01/2024	64827	Victor A. Mortson	054 GATE Private Instrument Lessons - MMS	500.00
			054 GATE Private Instrument Lessons - MMS	11-054-1000-322-251-0000-000-505	11/01/2024	500.00
11	1143	11/01/2024	68571	Karsten Rex Longhurst	054 GATE High School Choir Clinician	250.00
			054 GATE High School Choir Clinician	11-054-1000-322-251-0000-000-705	11/01/2024	250.00
11	1144	11/01/2024	68556	Julie Yu-Oppenheim	054 GATE High School Choir Clinician	250.00
			054 GATE High School Choir Clinician	11-054-1000-322-251-0000-000-705	11/01/2024	250.00
11	1145	11/01/2024	68561	Jim F Graves	054 GATE High School Choir Clinician	250.00
			054 GATE High School Choir Clinician	11-054-1000-322-251-0000-000-705	11/01/2024	250.00
11	1146	11/01/2024	66529	KEEGAN BUCKALOO	054 GATE Show Choir Choreography - Fall	400.00
			054 GATE Show Choir Choreography - Fall	11-054-1000-322-251-0000-000-705	11/01/2024	400.00
11	1147	11/01/2024	66529	KEEGAN BUCKALOO	054 GATE Show Choir Choreography - Spring	2,000.00
			054 GATE Show Choir Choreography - Spring	11-054-1000-322-251-0000-000-705	11/01/2024	2,000.00
11	1148	11/01/2024	68660	Oklahoma Film Actors Studio	054 GATE Breathwork Pedagogy Accommodations	360.00
			054 Accommodations for Rob Hahn (11/07/24) - Breathwork Pedagogy	11-054-1000-580-251-0000-000-505	11/01/2024	90.00
				11-054-1000-580-251-0000-000-510	11/01/2024	90.00
				11-054-1000-580-251-0000-000-525	11/01/2024	90.00
				11-054-1000-580-251-0000-000-705	11/01/2024	90.00
11	1149	11/01/2024	14462	Amazon Capital Services Inc.	412 Classroom Supplies (S LaPlace)	200.00
			412 Shadai LaPlace Classroom Supplies such as corrugated cardboard sheets, colored felt, building bricks etc.	11-412-1000-681-315-8700-000-145	11/01/2024	200.00
11	1150	11/01/2024	14462	Amazon Capital Services Inc.	412 Classroom Supplies (G Osborne)	750.00
			412 Greg Osborne Classroom Supplies such as paper photography backdrops, brackets, C-Stand w/boom arm, photography photo props etc.	11-412-1000-681-316-8100-000-705	11/01/2024	750.00
11	1151	11/01/2024	14462	Amazon Capital Services Inc.	412 Classroom Supplies (V Baca)	25.00
			412 Vanessa Baca Classroom Supplies	11-412-1000-681-315-8700-000-160	11/01/2024	25.00
11	1152	11/01/2024	14462	Amazon Capital Services Inc.	412 Classroom Supplies (R Swan)	650.00
			412 Rhoda Swan Classroom Supplies such as painters tapes, rubber bands, protective shield glasses, industrial masking tape, utility cart etc.	11-412-1000-681-315-8700-000-510	11/01/2024	650.00

Encumbrance Register

Options: Year: 2024-2025, Date Range: 10/10/2024 - 11/7/2024, PO Range: 1057 - 5000, Fund(s): 11-General

Fund	PO No	Date	Vendor No	Vendor	Description	Amount
11	1153	11/01/2024	12994	PITSCO EDUCATION, LLC	412 Classroom Materials (R Swan)	350.00
				412 Rhoda Swan Classroom Materials such as worm gear replacement/correct tools for Robotics	11-412-1000-681-315-8700-000-510 11/01/2024	350.00
11	1154	11/01/2024	68945	Robert Hahn	054 GATE Breathwork Pedagogy (HS/Middle Schools)	1,100.00
				054 GATE Breathwork Pedagogy at the HS and Middle Schools	11-054-1000-322-251-0000-000-505 11/01/2024	275.00
					11-054-1000-322-251-0000-000-510 11/01/2024	275.00
					11-054-1000-322-251-0000-000-525 11/01/2024	275.00
					11-054-1000-322-251-0000-000-705 11/01/2024	275.00
11	1155	11/01/2024	14462	Amazon Capital Services Inc.	054 GATE Classroom Supplies (A Myers)	350.00
				054 GATE Classroom Supplies for Anna Myers such as balloons, digital chess clocks, cotton balls, bakers twine, toothpicks, etc.	11-054-1000-681-251-0000-000-160 11/01/2024	350.00
11	1156	11/01/2024	20362	Grizzly Industrial Inc	412 Classroom Materials M Moore	150.00
				412 Matt Moore Classroom Materials	11-412-1000-681-315-8700-700-705 11/01/2024	150.00
11	1157	11/01/2024	63566	REV Robotics LLC	412 Classroom Materials M Stephens	550.00
				412 Matt Stephens Classroom Materials (2 x REV Robotics Expansion Hubs)	11-412-1000-681-315-8700-000-505 11/01/2024	550.00
11	1158	11/01/2024	14462	Amazon Capital Services Inc.	412 Classroom Supplies (K Pumford)	750.00
				412 Kristin Pumford Classroom Supplies such as felt fabric sheets, jumbo rickrack, button looping, trim ribbons, bias tapes, sewing elastic bands etc.	11-412-1000-681-314-8400-000-705 11/01/2024	750.00
11	1159	11/01/2024	67956	Howard industries Inc	002- Smart Boards for Classrooms	5,695.00
				002- HSSmartboards for Eric Peterson and N. Huepel	11-002-1000-653-900-0000-000-705 11/01/2024	3,782.00
				1456324.00 Newline 75' Q Pro series 4K LED 4K Multi-Touch Display w/ USB Type-C, Google EDLA Certified MPN: TT-7524QP		
				43/55/65/75/86 Wall Mount MPN: EPR8A50600-000 Newline EPR8A50500-SQR MPN: EPR8A50500-SQR Shipping & Handling	11-002-1000-653-900-0000-000-705 11/01/2024	1,913.00
11	1160	11/05/2024	15365	ABDO PUBLISHING	003 Books for Students MEDIA	1,329.20
				003 - Books MEDIA	11-003-2220-641-100-1050-000-115 11/05/2024	1,329.20
11	1161	11/05/2024	14915	VERNIER SOFTWARE & TECHNOLOGY	071 MMS SREB Grant Direct Motion Dectector	141.00
				071 MMS SREB Grant ItemGo Direct Motion Detector	11-071-1000-619-100-0000-000-505 11/05/2024	141.00
11	1162	11/05/2024	66397	MNJ TECHNOLOGIES DIRECT, INC.	002-smartboard projector bulbs	675.00
				smartboard projector bulbs- 4 BTI projector lamp and 4 Epson lamp bulbs.	11-002-1000-653-900-0000-000-110 11/05/2024	675.00

Encumbrance Register

Options: Year: 2024-2025, Date Range: 10/10/2024 - 11/7/2024, PO Range: 1057 - 5000, Fund(s): 11-General

Fund	PO No	Date	Vendor No	Vendor	Description	Amount
11	1163	11/05/2024	14462	Amazon Capital Services Inc.	012-Drone Battery	108.96
			11-012-2490-653-100-0000-000-050		11/05/2024	108.96
				012-Phantom 4 Battery 15.2V 5870mAh, Homesuit High Capacity Intelligent Flight Replacement Battery Pack for DJI Phantom 4 Series Drone DJI Phantom 4, Phantom 4 Pro, Phantom 4 Pro V2.0, Phantom 4 Advanced		
11	1164	11/06/2024	22211	ARCHWAY MARKETING SERVICES	333-Elementary Math Textbooks	3,300.00
			11-333-1000-641-100-2200-000-120		11/06/2024	1,200.00
				BIL OKLAHOMA 2025 MATH GR4 STUDENT EDITION SET 6YR LARSON 1ST EDITION (K12,2025) 9798888037072-8888037071		
			11-333-1000-641-100-2200-000-120		11/06/2024	1,800.00
				BIL OKLAHOMA 2025 MATH GR1 STUDENT EDITION SET 6YR LARSON 1ST EDITION (K12, 2025 9798888036891/888803689X		
			11-333-1000-641-100-2200-000-120		11/06/2024	300.00
				SHIPPING		
11	1165	11/06/2024	68973	Matthew James Heagerty	11-002 Author Visit 12/9	900.00
			11-002-1000-322-100-0000-000-160		11/06/2024	900.00
				12/9/24 Author Visit 1/2 day		
11	1166	11/06/2024	62734	Professional Basketball Club, LLC	561- Native American Student Day	2,000.00
			11-561-1000-810-100-0000-000-000		11/06/2024	2,000.00
				Cultural and Educational Event for Title VI Students		
11	1167	11/06/2024	64814	REBECCA LITTLE	054 GATE Private Instrument Lessons - MCMS	1,000.00
			11-054-1000-322-251-0000-000-525		11/06/2024	1,000.00
				054 GATE Private Instrument Lessons - MCMS		
11	1168	11/06/2024	64827	Victor A. Mortson	054 GATE Private Instrument Lessons - MCMS	1,000.00
			11-054-1000-681-322-0000-000-525		11/06/2024	1,000.00
				054 GATE Private Instrument Lessons - MCMS		
11	1169	11/06/2024	12706	OAEA ASSOC	054 Registration OAEA (E Odom) 11/15-11/16, 2024	150.00
			11-054-2213-860-251-0000-000-705		11/06/2024	150.00
				054 Registration Fee for Emily Odom to Attend OAEA at UCO November 15 -16, 2024		
11	1170	11/06/2024	12706	OAEA ASSOC	054 Registration OAEA (G Thompson) 11/15-11/16/24	150.00
			11-054-2213-860-251-0000-000-705		11/06/2024	150.00
				054 Registration Fee for Gina Thompson to Attend OAEA at UCO November 15-16, 2024		
11	1171	11/06/2024	12706	OAEA ASSOC	054 Reg. OAEA (V McIntire) 11/15-11/16, 20024	150.00
			11-054-2213-860-251-0000-000-705		11/06/2024	150.00
				054 Registration Fee for Vanessa McIntire to Attend OAEA at UCO November 15-16, 2024		
11	1172	11/06/2024	12706	OAEA ASSOC	054 Registration OAEA (R Tilley) 11/15-11/16, 2024	150.00
			11-054-2213-860-251-0000-000-705		11/06/2024	150.00
				054 Registration Fee for Rachel Tilley to Attend OAEA at UCO November 15 -16, 2024		
11	1173	11/06/2024	12706	OAEA ASSOC	054 Registration OAEA (S Machado) 11/15-11/16,2024	150.00
			11-054-2213-860-251-0000-000-705		11/06/2024	150.00
				054 Registration Fee for Sierra Machado to Attend OAEA at UCO November 15-16, 2024		

Encumbrance Register

Options: Year: 2024-2025, Date Range: 10/10/2024 - 11/7/2024, PO Range: 1057 - 5000, Fund(s): 11-General

Fund	PO No	Date	Vendor No	Vendor	Description	Amount	
11	1181	11/07/2024	65090	SWIVL, INC	541: License Renewal for Reflectivity	1,320.00	
				541: License Renewal for ReflectivityInstructional Coach Training Devices	11-541-2213-653-429-0000-000-105 11-541-2213-653-429-0000-000-110 11-541-2213-653-429-0000-000-115 11-541-2213-653-429-0000-000-120 11-541-2213-653-429-0000-000-125 11-541-2213-653-429-0000-000-135 11-541-2213-653-429-0000-000-140 11-541-2213-653-429-0000-000-145 11-541-2213-653-429-0000-000-150 11-541-2213-653-429-0000-000-155 11-541-2213-653-429-0000-000-160 11-541-2213-653-429-0000-000-505 11-541-2213-653-429-0000-000-510 11-541-2213-653-429-0000-000-525 11-541-2213-653-429-0000-000-705	11/07/2024 11/07/2024 11/07/2024 11/07/2024 11/07/2024 11/07/2024 11/07/2024 11/07/2024 11/07/2024 11/07/2024 11/07/2024 11/07/2024 11/07/2024 11/07/2024 11/07/2024 11/07/2024	88.00 88.00 88.00 88.00 88.00 88.00 88.00 88.00 88.00 88.00 88.00 88.00 88.00 88.00 88.00
11	1182	11/07/2024	65090	SWIVL, INC	541 Swivl Reflectivity Individual License Renewal	1,320.00	
				541 - (15) Reflectivity Individual License Renewal, 1 Year	11-541-2213-653-000-0000-000-050	11/07/2024	1,320.00
11	1183	11/07/2024	10170	Apple, Inc.	412 Classroom Tech Support (V Baca)	110.63	
				412 Vanessa Baca Classroom Tech SupportApp Stop Motion Studio Pro\$5.99 each x 37 = \$221.63	11-412-1000-653-315-8700-000-160	11/07/2024	110.63
Non-Payroll Total:						\$156,249.95	
Payroll Total:						\$0.00	
Balance Forward:						\$216.00	
Report Total:						\$156,465.95	

Encumbrance Register

Options: Year: 2024-2025, Date Range: 10/10/2024 - 11/7/2024, PO Range: 164 - 5000, Fund(s): 21-Building

Fund	PO No	Date	Vendor No	Vendor	Description	Amount
21	164	10/11/2024	64132	UNITED MECHANICAL SERVICE, INC	038-Valves & piping materials for LE	1,573.00
					038-Valves & piping materials for Lakehoma.	
			21-038-2620-453-000-0000-000-115		10/11/2024	1,573.00
21	165	10/15/2024	14462	Amazon Capital Services Inc.	031-wireless keyboard & mouse-Brian Keith	36.98
					031-Wireless keyboard & mouse for Brian Keith	
			21-031-2620-653-000-0000-000-050		10/15/2024	36.98
21	166	10/15/2024	23115	SCOVIL & SIDES HARDWARE CO	032-Keys & hardware for district wide use	1,000.00
					032-Keys & hardware for district wide use	
			21-032-2620-618-000-0000-000-050		10/15/2024	125.00
			21-032-2620-618-000-0000-000-050		10/15/2024	129.00
			21-032-2620-618-000-0000-000-050		10/15/2024	746.00
21	167	10/16/2024	11609	HUNZICKER BROTHERS, INC.	036-Coil kits for HZI	274.74
					036-2 Coil kits for HZI	
			21-036-2620-655-000-0000-000-140		10/16/2024	274.74
21	168	10/21/2024	63161	Stryker Integrated Solutions LLC	036-Fire/burglar alarm repairs	5,000.00
					036-Fire/burglar alarm repairs district wide	
			21-036-2620-438-000-0000-000-050		10/21/2024	1,750.00
			21-036-2620-438-000-0000-000-050		10/21/2024	3,250.00
21	169	10/21/2024	63099	EXCEL DRYER, INC.	038-Hand dryer replacements for MHS	2,400.00
					038-5 hand dryer replacements for the high school	
			21-038-2620-656-000-0000-000-705		10/21/2024	2,300.00
					038-Increase PO#2025-21-169 for freight charges	
			21-038-2620-656-000-0000-000-705		10/22/2024	100.00
21	170	10/21/2024	66758	PERFORMANCE ELECTRIC INC.	038-High school transformer issues	4,875.00
					038-High school emergency transformer issues	
			21-038-2620-656-000-0000-000-705		10/21/2024	4,875.00
21	171	10/29/2024	64132	UNITED MECHANICAL SERVICE, INC	036-Leak check at MHS Media Ctr	1,696.00
					036-Labor & materials to leak check VRF system at MHS Media Ctr	
			21-036-2620-453-000-0000-000-705		10/29/2024	1,696.00
21	172	10/29/2024	62711	LENNOX INDUSTRIES INC	036-R410A refrigerant for DW use	7,074.80
					036-R410A refrigerant for district wide use	
			21-036-2620-618-000-0000-000-050		10/29/2024	7,074.80
21	173	10/29/2024	63161	Stryker Integrated Solutions LLC	038-Fire extinguisher maintenance dw	10,885.00
					038-Fire extinguisher maintenance dw- (116) 6 year maint, (91) 12 year hydro.	
			21-038-2620-438-000-0000-000-050		10/29/2024	10,885.00
21	174	10/29/2024	68563	Baker Distributing Company LLC	036-Ice thickness probe for FB field house	156.20
					036-Ice thickness probe for ice machine at the football field house.	
			21-036-2620-618-000-0000-000-705		10/29/2024	156.20
21	175	10/31/2024	15346	CENTRAL OKLAHOMA WINNELSON	036-Water heater for MHS J hall	2,152.53
					036-Water heater for MHS J hall	
			21-036-2620-656-000-0000-000-705		10/31/2024	2,152.53
21	176	10/31/2024	10108	AMUNDSEN FOOD EQUIPMENT	089-Dishwasher	43,500.00
					089-Conveyor type Dishwasher and Install for Mustang South Middle School	
			21-089-2620-731-000-0000-000-505		10/31/2024	43,500.00

Encumbrance Register

Options: Year: 2024-2025, Date Range: 10/10/2024 - 11/7/2024, PO Range: 164 - 5000, Fund(s): 21-Building

Fund	PO No	Date	Vendor No	Vendor	Description	Amount
21	177	10/31/2024	68957	Quality Stainless, LLC	089-Walk In Freezer 10/31/2024	67,000.00 67,000.00
089-Walk in freezer, modular remove, delivery and construction of unit, refrigeration installation, electrical and security unit. 21-089-2620-731-000-0000-000-105						
21	178	11/01/2024	14462	Amazon Capital Services Inc.	Misc. parts & supplies as needed 11/01/2024	500.00 500.00
Misc parts & Supplies as needed 21-034-2620-618-000-0000-000-050						
21	179	11/06/2024	11262	Endex of Oklahoma, Inc.	038-Replace 500' faulty underground wiring at CRI 11/06/2024	6,375.00 6,375.00
038-Replace 500' faulty underground wiring at CRI office for intercom & bells 21-038-2620-438-000-0000-000-145						
Non-Payroll Total:						\$154,499.25
Payroll Total:						\$0.00
Balance Forward:						\$0.00
Report Total:						\$154,499.25

Encumbrance Register

Options: Year: 2024-2025, Date Range: 10/10/2024 - 11/7/2024, PO Range: 40 - 5000, Fund(s): 33-2023 Recurring

Fund	PO No	Date	Vendor No	Vendor	Description	Amount	
33	40	10/11/2024	66794	MOSYLE CORPORATION	066 Vocal Tech Ipad Subscription	72.64	
				066 Premium Subscription Mosyle	33-066-1000-653-100-3071-000-140	10/11/2024	9.08
				Manager MDM for Vocal Ipads	33-066-1000-653-100-3071-000-145	10/11/2024	9.08
					33-066-1000-653-100-3071-000-160	10/11/2024	9.08
					33-066-1000-653-100-3071-000-505	10/11/2024	9.08
					33-066-1000-653-100-3071-000-510	10/11/2024	9.08
					33-066-1000-653-100-3071-000-525	10/11/2024	9.08
					33-066-1000-653-100-3071-000-705	10/11/2024	18.16
33	41	10/15/2024	14462	Amazon Capital Services Inc.	066 DMX Light/Fog Machine Controller MCMS Theatre	159.99	
				066 CHAUVET DJ OBEY40 Universal	33-066-1000-619-100-1125-000-525	10/15/2024	150.00
				DMX Light/Fog Machine Controller			
				066 Increase to PO 2025-33-41 due to	33-066-1000-619-100-1125-000-525	10/21/2024	9.99
				price increase on DMX Light/Fog			
				Machine Controller for MCMS			
				Theater			
33	42	10/31/2024	14462	Amazon Capital Services Inc.	066 Stage Lights for MCMS Theatre	512.00	
				066 LED Par Stage Light - RGBWA	33-066-1000-619-100-1125-000-525	10/31/2024	512.00
				70W 7LED Stage Par Light Sound			
				Activated Auto Play by Remote &			
				DMX Control Uplighting for Events			
				Birthday Wedding Party Church Music			
				Live Show Concert DJ Lighting			
33	43	11/01/2024	17010	Dealers Electrical Supply Co	066 Kiln Installation at MHS	1,500.00	
				066 Material and Installation for MHS	33-066-2620-434-000-0000-000-705	11/01/2024	1,500.00
				Kiln in art room			

Non-Payroll Total:	\$2,244.63
Payroll Total:	\$0.00
Balance Forward:	\$0.00
Report Total:	\$2,244.63

Mustang Public Schools
Change Order Listing

Options: Fund(s): 11-General, Year: 2024-2025, ReferenceDate: PO Date, Date Range: 10/1/2024 - 10/1/2024, Include Negative Changes: False

PO No	Date	Vendor No	Vendor	Description	Amount	
782	09/05/2024	67711	FCCLA, Inc.	412 - FCCLA Membership Affiliation Package	24.00	
		11-412-1000-811-314-8400-000-510		09/05/2024	10/01/2024	-500.00
		11-412-1000-811-314-8400-000-510		10/01/2024		500.00
		11-412-1000-811-314-8400-000-510		10/01/2024		24.00

412 FCCLA Membership Affiliation Package for Christina Roby
 412 Increase to PO782 for FCCLA Membership Affiliation Package for Christina Roby
 The additional amount was not requested on the original PO request

Non-Payroll Total:	\$24.00
Payroll Total:	\$0.00
Report Total:	\$24.00

Project Totals

412	VOCATIONAL PRGMS INCENTIVE	24.00
-----	----------------------------	-------

Unit Totals

510	North Middle	24.00
-----	--------------	-------

Change Order Listing

Options: Fund(s): 11-General, Year: 2024-2025, ReferenceDate: PO Date, Date Range: 10/10/2024 - 11/7/2024, PO Range: 1 - 1056, Include Negative Changes: False

PO No	Date	Vendor No	Vendor	Description	Amount	
101	07/01/2024	14462	Amazon Capital Services Inc.	041 Blanket Assistive Technology	500.00	
	041 Increase PO 11-101	11-041-2490-619-239-0000-000-050		10/23/2024	500.00	
130	07/01/2024	10064	All Season Building Supply Co Inc	023 - BLANKET PARTS & SUPPLIES	300.00	
	INCREASE P.O. 11-130	11-023-3140-618-700-0000-000-050		10/30/2024	300.00	
247	07/10/2024	10027	Charrick Associates	023 - BLANKET LOCK AND KEYS	100.00	
	INCREASE P.O. 247	11-023-3140-618-700-0000-000-050		10/30/2024	100.00	
287	07/22/2024	67515	THEMES & VARIATIONS, INC	552 -Music Play/Themes & Variations	21.60	
	Music Play/Themes & Variations	11-552-1000-653-496-0000-000-105		07/22/2024	10/10/2024	-196.37
	Online Licenses (12)	11-552-1000-653-496-0000-000-110		07/22/2024	10/10/2024	-196.37
		11-552-1000-653-496-0000-000-115		07/22/2024	10/10/2024	-196.37
		11-552-1000-653-496-0000-000-120		07/22/2024	10/10/2024	-196.37
		11-552-1000-653-496-0000-000-125		07/22/2024	10/10/2024	-196.37
		11-552-1000-653-496-0000-000-135		07/22/2024	10/10/2024	-196.37
		11-552-1000-653-496-0000-000-140		07/22/2024	10/10/2024	-196.37
		11-552-1000-653-496-0000-000-145		07/22/2024	10/10/2024	-196.37
		11-552-1000-653-496-0000-000-150		07/22/2024	10/10/2024	-196.37
		11-552-1000-653-496-0000-000-155		07/22/2024	10/10/2024	-196.37
		11-552-1000-653-496-0000-000-160		07/22/2024	10/10/2024	-196.30
		11-552-1000-653-496-0000-000-105		10/10/2024		196.37
		11-552-1000-653-496-0000-000-110		10/10/2024		196.37
		11-552-1000-653-496-0000-000-115		10/10/2024		196.37
		11-552-1000-653-496-0000-000-120		10/10/2024		196.37
		11-552-1000-653-496-0000-000-125		10/10/2024		196.37
		11-552-1000-653-496-0000-000-135		10/10/2024		196.37
		11-552-1000-653-496-0000-000-140		10/10/2024		196.37
		11-552-1000-653-496-0000-000-145		10/10/2024		196.37
		11-552-1000-653-496-0000-000-150		10/10/2024		196.37
		11-552-1000-653-496-0000-000-155		10/10/2024		196.37
		11-552-1000-653-496-0000-000-160		10/10/2024		196.30
	412 Increase to PO287 for Themes and Variations REASON: The payment was made with school credit card and the processor charged an international fee for the payment.	11-051-0000-000-000-0000-000-105		10/15/2024		1.96
		11-051-0000-000-000-0000-000-110		10/15/2024		1.96
		11-051-0000-000-000-0000-000-115		10/15/2024		1.97
		11-051-0000-000-000-0000-000-120		10/15/2024		1.97
		11-051-0000-000-000-0000-000-125		10/15/2024		1.97
		11-051-0000-000-000-0000-000-135		10/15/2024		1.97
		11-051-0000-000-000-0000-000-140		10/15/2024		1.96
		11-051-0000-000-000-0000-000-145		10/15/2024		1.96
		11-051-0000-000-000-0000-000-150		10/15/2024		1.96
		11-051-0000-000-000-0000-000-155		10/15/2024		1.96
		11-051-0000-000-000-0000-000-160		10/15/2024		1.96
744	09/03/2024	67046	COMMERCE BANK	561-Title VI Program Printing	500.00	
	561- Increase to PO#744: Title VI Program Printing	11-561-2199-611-000-0000-000-050		10/23/2024	500.00	
791	09/06/2024	13963	CAPITAL ONE TRADE CREDIT	005- Science Dept Supplies for Classroom	175.00	
	005- HS Science Dept.Additional classroom supplies needed	11-005-1000-619-100-0000-000-705		10/21/2024	175.00	
989	09/30/2024	87461	Melissa Anne Sullinger	541 M Sullinger Mileage (OSCA Conf.)	30.00	
	541 Increase to PO989 Mileage for Melissa Sullinger to attend OSCA,	11-541-2213-580-000-0000-000-140		10/23/2024	30.00	

Change Order Listing

Options: Fund(s): 11-General, Year: 2024-2025, ReferenceDate: PO Date, Date Range: 10/10/2024 - 11/7/2024, PO Range: 1 - 1056, Include Negative Changes: False

PO No	Date	Vendor No	Vendor	Description	Amount
990	09/30/2024	84177	Amber Rae Northcutt	541 A Northcutt Mileage (OSCA Conf.)	30.00
				Norman OK Reason: Initial PO requested amount was for 1 day of travel instead of 2 days	
				541 Increase to PO990 Mileage for Amber Northcutt to attend OSCA, Norman OK Reason: Initial PO requested amount was for 1 day of travel instead of 2 days	30.00
991	09/30/2024	86821	Melissa Gail Hartzell	541 Melissa Hartzell Mileage (OSCA Conf.)	30.00
				11-541-2213-580-000-0000-000-160	
				541 Increase to PO991 Mileage for Melissa Hartzell to attend OSCA, Norman OK Reason: Initial PO requested amount was for 1 day of travel instead of 2 days	30.00
992	09/30/2024	86035	Michael Lynn Barrick	541 Mike Barrick Mileage (OSCA Conf.)	30.00
				11-541-2213-580-000-0000-000-050	
				541 Increase to PO992 Mileage for Mike Barrick to attend OSCA, Norman OK Reason: Initial PO requested amount was for 1 day of travel instead of 2 days	30.00
993	09/30/2024	87490	Lynn Warden	541 Lynn Warden Mileage (OSCA Conf.)	30.00
				11-541-2213-580-000-0000-000-705	
				541 Increase to PO993 Mileage for Lynn Warden to attend OSCA, Norman OK Reason: Initial PO requested amount was for 1 day of travel instead of 2 days	30.00
994	09/30/2024	87499	Elizabeth Marie Karnes	541 Elizabeth Karnes Mileage (OSCA Conf.)	30.00
				11-541-2213-580-000-0000-000-135	
				541 Increase to PO994 Mileage for Elizabeth Karnes to attend OSCA, Norman OK Reason: Initial PO requested amount was for 1 day of travel instead of 2 days	30.00
995	09/30/2024	86799	Hannah Gray	541 Hannah Gray Mileage (OSCA Conf.)	30.00
				11-541-2213-580-000-0000-000-135	
				541 Increase to PO995 Mileage for Hannah Gray to attend OSCA, Norman OK Reason: Initial PO requested amount was for 1 day of travel instead of 2 days	30.00
996	09/30/2024	85386	Sheadrian Nicole Cartwright	541 Sheadrian Cartwright Mileage (OSCA Conf.)	30.00
				11-541-2213-580-000-0000-000-155	
				541 Increase to PO996 Mileage for Sheadrian Cartwright to attend OSCA, Norman Reason: Initial PO requested amount was for 1 day of travel instead of 2 days	30.00
997	09/30/2024	85778	Melessia Kay Hopson	541 Melissa Hopson Mileage (OSCA Conf.)	300.00
				11-541-2213-580-000-0000-000-155	
				541 Increase to PO997 Mileage for Melissa Hopson to attend OSCA, Norman OK Reason: Initial PO requested amount was for 1 day of travel instead of 2 days	300.00

Change Order Listing

Options: Fund(s): 11-General, Year: 2024-2025, ReferenceDate: PO Date, Date Range: 10/10/2024 - 11/7/2024, PO Range: 1 - 1056, Include Negative Changes: False

PO No	Date	Vendor No	Vendor	Description	Amount
999	09/30/2024	83247	Kara Don Karr	541 Kara Karr Mileage (OSCA Conf.)	30.00
				541 Increase to PO999 Mileage for Kara Karr to attend OSCA, Norman OK Reason: Initial PO requested amount was for 1 day of travel instead of 2 days	30.00
		11-541-2213-580-000-0000-000-115		10/23/2024	30.00

Non-Payroll Total:	\$2,166.60
Payroll Total:	\$0.00
Report Total:	\$2,166.60

Project Totals

005	Site Science Budget	175.00
023	Child Nutrition	400.00
041	Special Ed (Budget/Salaries)	500.00
051	Federal Programs	21.60
541	TITLE II, PART A, TCHR/PRINC.	570.00
552	TITLE IV LEAS FORMULA	0.00
561	INDIAN EDUCATION	500.00

Unit Totals

050	District Wide	1,430.00
105	Mustang Elem	1.96
110	Valley Elem	1.96
115	Lakehoma Elem	31.97
120	Trails Elem	1.97
125	Creek Elem	1.97
135	Centennial Elem	61.97
140	Horizon Int	31.96
145	Canyon Ridge Int	1.96
150	Prairie View Elem	1.96
155	Riverwood Elem	331.96
160	Meadow Brook Int	61.96
705	Mustang High	205.00

Change Order Listing

Options: Fund(s): 21-Building, Year: 2024-2025, ReferenceDate: PO Date, Date Range: 10/10/2024 - 11/7/2024, PO Range: 1 - 163, Include Negative Changes: False

PO No	Date	Vendor No	Vendor	Description	Amount	
137	09/03/2024	67046	COMMERCE BANK	037-Motor, seats, fender, and door assy	154.00	
	037-Purchase a rebuilt motor, front seat, front door assy, and a fender. These items are for the 2009 Chevy Silverado, 3500.	21-037-2640-656-000-0000-000-050		09/03/2024	10/15/2024	-5,532.00
		21-037-2640-656-000-0000-000-050		10/15/2024		5,532.00
	037-Increase PO# 2025-21-137	21-037-2620-656-000-0000-000-050		10/15/2024		154.00
Non-Payroll Total:					\$154.00	
Payroll Total:					\$0.00	
Report Total:					\$154.00	

Project Totals

037	White Fleet	154.00
-----	-------------	--------

Unit Totals

050	District Wide	154.00
-----	---------------	--------

MUSTANG SCHOOLS - TREASURER'S REPORT

As of October 31, 2024

GOVERNMENTAL FUNDS		
Bank Statements		
Bank of Oklahoma Revenue Account	\$	0.00
Bank of Oklahoma Expenditure Account	\$	0.00
BOK Cavanal Hill General Fund Sweep Account	\$	3,084,179.75
4.74 % as of 10/31/2024		
BOK ICS Investments - General Fund	\$	22,614,042.74
4.75 % as of 10/31/2024		
Subtotal	\$	25,698,222.49
Computer Cash Balance	\$	25,698,222.48
*** American Fidelity Product	\$	0.01

Reconciliation - Should equal \$0.00	\$	(0.00)
Total - Governmental Funds	\$	25,698,222.49

ACTIVITY FUNDS		
Bank Statements		
Bank of Oklahoma Account	\$	1,302.39
BOK Cavanal Hill Activity Sweep Account	\$	576,036.09
4.74% as of 10/31/2024		
OLAP Investments - Activity Fund	\$	4,750,721.25
4.75% as of 10/31/2024		
All America Bank Certificates of Deposit	\$	240,579.93
4.25%		
Subtotal	\$	5,568,639.66
Computer Cash Balance	\$	5,497,711.39
Plus Outstanding Warrants	\$	70,928.27
Adjusted Computer Cash Balance	\$	5,568,639.66
*** Exceptions: None	\$	0.00
Reconciliation - Should equal \$0.00	\$	0.00
Total - Activity Fund	\$	5,568,639.66

OTHER FUNDS		
Commerce Bank - Governmental Revenue Share	\$	156,779.65
Commerce Bank - Activity Revenue Share	\$	70,696.56

TOTAL CASH ASSETS	\$	31,494,338.36
--------------------------	-----------	----------------------

GOVERNMENTAL FUND CASH BALANCES		
Fund 11 - General Fund	\$	4,941,682.54
Fund 21 - Building Fund	\$	2,588,587.94
Fund 33 - 2023 Recurring Bond Funds	\$	1,800,447.59
Fund 34 - 2012 Recurring Bond Funds	\$	2,256,596.78
Fund 38 - Transportation Bond	\$	838,684.00
Fund 41 - Sinking Fund	\$	10,758,997.73
Fund 86 - Insurance Recoveries	\$	2,513,225.90

MONTHLY PAYROLL		
Total Payroll	\$	9,021,974.28

Chad Buef

Date: *11/7/24*

Mustang Public Schools

Revenue Analysis

Options: Type of Revenue: Estimated, As Of Date: 10/31/2024

	Estimated Revenue	Revenue Collected	Revenue Receivable	Unappropriated Receipts	% Rev Collected	Current Month
Fund - 11 11-General						
Series - 1000						
Source - 1120 Ad Valorem Prior Years	\$0.00	\$804,222.57	\$0.00	\$804,222.57	N/A	\$58,535.91
Source - 1190 Other Taxes	\$0.00	\$0.00	\$0.00	\$0.00	N/A	\$0.00
Source - 1310 Interest Earnings	\$0.00	\$8,357.83	\$0.00	\$8,357.83	N/A	\$2,863.31
Source - 1312 Investment Earnings	\$0.00	\$754,703.74	\$0.00	\$754,703.74	N/A	\$97,540.49
Source - 1351 Interest on Protested taxes	\$0.00	\$80.54	\$0.00	\$80.54	N/A	\$0.00
Source - 1352 Unapportioned Interest	\$0.00	\$3,344.59	\$0.00	\$3,344.59	N/A	\$540.37
Source - 1440 Sales of Equipment	\$0.00	\$410.00	\$0.00	\$410.00	N/A	\$0.00
Source - 1510 Insurance Loss Recovery	\$0.00	\$17,694.90	\$0.00	\$17,694.90	N/A	\$17,694.90
Source - 1590 Misc Reimbursements	\$0.00	\$3,495.00	\$0.00	\$3,495.00	N/A	\$0.00
Source - 1620 Community Service	\$0.00	\$3,455.00	\$0.00	\$3,455.00	N/A	\$0.00
Source - 1680 Refund of PY Expense	\$0.00	\$598.86	\$0.00	\$598.86	N/A	\$0.00
Source - 1690 Misc Revenue/ District	\$0.00	\$18,600.00	\$0.00	\$18,600.00	N/A	\$0.00
Source - 1795 Promotional Rebate	\$0.00	\$13,218.44	\$0.00	\$13,218.44	N/A	\$5,648.44
Series - 1000 Total	\$0.00	\$1,628,181.47	\$0.00	\$1,628,181.47	N/A	\$182,823.42
Series - 2000						
Source - 2100 County 4 Mill Tax	\$0.00	\$74,411.11	\$0.00	\$74,411.11	N/A	\$18,806.92
Source - 2200 County Mortgage Tax	\$0.00	\$217,138.53	\$0.00	\$217,138.53	N/A	\$56,495.08
Series - 2000 Total	\$0.00	\$291,549.64	\$0.00	\$291,549.64	N/A	\$75,302.00
Series - 3000						
Source - 3110 Gross Production	\$0.00	\$1,480,817.80	\$0.00	\$1,480,817.80	N/A	\$379,084.18
Source - 3120 Motor Vehicle	\$0.00	\$1,627,653.50	\$0.00	\$1,627,653.50	N/A	\$522,955.73
Source - 3130 Rural Electric	\$0.00	\$71,023.18	\$0.00	\$71,023.18	N/A	\$19,998.94
Source - 3140 State School Land	\$0.00	\$713,350.94	\$0.00	\$713,350.94	N/A	\$179,172.31
Source - 3150 Vehicle Tax Stamp	\$0.00	\$2,480.39	\$0.00	\$2,480.39	N/A	\$489.59
Source - 3210 State Aid	\$0.00	\$13,754,654.78	\$0.00	\$13,754,654.78	N/A	\$4,584,884.93
Source - 3250 Flex Benefit Allowance	\$0.00	\$2,686,599.86	\$0.00	\$2,686,599.86	N/A	\$895,533.29
Source - 3400 State-Categorical	\$0.00	\$0.00	\$0.00	\$0.00	N/A	\$0.00
Source - 3420 State Textbook	\$0.00	\$864,655.16	\$0.00	\$864,655.16	N/A	\$0.00
Source - 3436 School Resource Officer	\$0.00	\$111,849.62	\$0.00	\$111,849.62	N/A	\$0.00
Source - 3437 Maternity Leave	\$0.00	\$60,765.93	\$0.00	\$60,765.93	N/A	\$60,765.93
Source - 3690 Misc State Revenue	\$0.00	\$3,380.00	\$0.00	\$3,380.00	N/A	\$0.00
Source - 3811 Career Tech Salary	\$0.00	\$5,940.00	\$0.00	\$5,940.00	N/A	\$0.00
Source - 3812 Career Tech Program	\$0.00	\$70,749.00	\$0.00	\$70,749.00	N/A	\$0.00
Series - 3000 Total	\$0.00	\$21,453,920.16	\$0.00	\$21,453,920.16	N/A	\$6,642,884.90
Series - 4000						
Source - 4140 Title VI Indian Education	\$0.00	\$108,760.16	\$0.00	\$108,760.16	N/A	\$19,111.66
Source - 4210 Title I/Part A	\$0.00	\$679,817.27	\$0.00	\$679,817.27	N/A	\$0.00
Source - 4271 Title II Part A	\$0.00	\$91,785.29	\$0.00	\$91,785.29	N/A	\$0.00
Source - 4281 Title III Part A ELL	\$0.00	\$9,178.90	\$0.00	\$9,178.90	N/A	\$0.00
Source - 4310 IDEA Part B	\$0.00	\$21,178.18	\$0.00	\$21,178.18	N/A	\$0.00
Source - 4442 Title IV Student Supp	\$0.00	\$3,223.29	\$0.00	\$3,223.29	N/A	\$0.00
Source - 4689 Other Misc Fed Rev	\$0.00	\$56,563.32	\$0.00	\$56,563.32	N/A	\$13,110.16
Source - 4710 Federal Lunch	\$0.00	\$600,164.95	\$0.00	\$600,164.95	N/A	\$344,997.02
Source - 4720 Federal Breakfast	\$0.00	\$148,660.56	\$0.00	\$148,660.56	N/A	\$89,432.89
Source - 4821 Carl Perkins	\$0.00	\$19,554.71	\$0.00	\$19,554.71	N/A	\$0.00
Series - 4000 Total	\$0.00	\$1,738,886.63	\$0.00	\$1,738,886.63	N/A	\$466,651.73
Series - 5000						
Source - 5160 Activity Fund Reimb	\$0.00	\$322,999.26	\$0.00	\$322,999.26	N/A	\$770.51
Source - 5600 Correcting Entry	\$0.00	\$5,503.57	\$0.00	\$5,503.57	N/A	\$4,425.49
Series - 5000 Total	\$0.00	\$328,502.83	\$0.00	\$328,502.83	N/A	\$5,196.00
Fund - 11 11-General Total	\$0.00	\$25,441,040.73	\$0.00	\$25,441,040.73	N/A	\$7,372,858.05
Report Total	\$0.00	\$25,441,040.73	\$0.00	\$25,441,040.73	N/A	\$7,372,858.05



MUSTANG PUBLIC SCHOOLS

Purpose of Activity Fund Account

School: Trails Title: PE Project#: 930 Program#: 900

Initial Form Amended Form (Indicate Additions with an *)

Fundraisers (selling items for a profit):

Description	Month Planned
<u>Cup stacking kit sales*</u>	<u>November 2024</u>
<u> </u>	<u> </u>
<u> </u>	<u> </u>
<u> </u>	<u> </u>
<u> </u>	<u> </u>
<u> </u>	<u> </u>

Other Sources of Revenue (income other than from fundraisers):

Donations,

Expenditures (how the funds will be spent):

Gym equipment, student rewards/prizes, professional development, office supplies

Christen Gelso
Sponsor Name (Please Print)

Christen Gelso
Sponsor Signature

10/24/2024 2024-25
Date Submitted School Year

Christy Waller 11.7.24
Activity Fund Custodian or CFO Signature

James Hasty
Principal or Director Signature

Date of Board Approval



MUSTANG PUBLIC SCHOOLS

Purpose of Activity Fund Account

School: Trails Title: Principal Project#: 931 Program#: 900

Initial Form Amended Form (Indicate Additions with an *)

Fundraisers (selling items for a profit):

Description	Month Planned
See attached form*	

Other Sources of Revenue (income other than from fundraisers):

Donations, Robotics fees, t-shirt sales, Scholastic News subscriptions, field trip money

Expenditures (how the funds will be spent):

t-shirts, office supplies, Robotics competition/fees/supplies, Scholastic renewals, food items for staff, snacks for students, buses for field trips, staff gifts, testing supplies, field trips, awards, sub reimbursement, fundraiser supplies, care/upkeep of grounds, professional development, cleaning supplies, office supplies, technology, books, travel expenses.

Brittney Brauer
Sponsor Name (Please Print)

Brittney Brauer
Sponsor Signature

[Signature]
Principal or Director Signature

10/29/2024
Date Submitted

2024-2025
School Year

Christy Walker 11-7-24
Activity Fund Custodian or CFO Signature

Date of Board Approval

Fundraiser for Principal 931	Month Planned
1 st and 2 nd grade pickles and popcorn	October
1 st grade candy cane sales	December
Tom Jackson photos	All year
Yearbook sales profits	All year
Trails T-shirt sales – office	September-December
Beast Week – Various fundraisers	January-March
Robotics student fees	All year
4 th grade pickles and popcorn*	January



OKLAHOMA PUBLIC SCHOOL INVESTMENT INTERLOCAL

2801 North Lincoln Boulevard, Suite 125 • Oklahoma City, OK 73105
(405) 528-3571 • (405) 528-5695 (FAX) • www.olaponline.org

October 14, 2024

To: Superintendents of Districts Belonging to the Oklahoma Public School Investment Interlocal [Oklahoma Liquid Asset Pool (OLAP)]

From: Dr. Shawn Hime, Board President

Re: Board of Directors' Nominee

The sponsoring organizations are recommending the following nominees to be presented to the boards of member districts. The nominee and the organization recommending the nominee are as follows:

Position No. 3: Lance Gibbs, Assistant Superintendent/CFO of Lawton Public Schools (CCOSA)

Position No. 5: Nancy Rogers, Director of Finance of Moore Norman Technology Center (OASBO)

Position No. 12: Don Tice, School Board Member of Oologah-Talala Public Schools (OSSBA)

Agenda items should read as follows:

Consideration and vote to elect or not to elect the following as new member of the board of directors of the Oklahoma Public School Investment Interlocal Cooperative (55K001):

Yes___ No___ Position No. 3: Lance Gibbs (CCOSA), Assistant Superintendent/CFO of Lawton Public Schools, to a 2025-2028 term.

Yes___ No___ Position No. 5: Nancy Rogers (OASBO), Director of Finance of Moore Norman Technology Center, to a 2025-2028 term.

Yes___ No___ Position No. 3: Don Tice (OSSBA), School Board Member of Oologah-Talala Public Schools, to a 2025-2028 term.

School District: _____

Board Clerk: _____

Please include this item on your November/December board agenda and notify the Oklahoma Public School Investment Interlocal of the action of your board, by returning the above ballot **via facsimile to Mong Chia, Board Clerk, at 405-528-5695 or email to mong@ossba.org by Friday, December 27, 2024.** Should you have any questions, feel free to contact me or Mong Chia at 405-528-3571. Your prompt reply is needed in order for the newly elected board member to begin his new term for the 2024 calendar year (January 1-December 31). Thank you for your cooperation.

Board of Education MEMO



To: Mustang Board of Education
CC: Charles Bradley, Superintendent

From: Dr. Jason Pittenger, Assistant Superintendent, Operations
State Contract for Athletic Surfacing

A handwritten signature in blue ink, appearing to be 'JP', is written over the 'From' line.

Date: 11/6/24

Contract Vendor: United Turf **Time Frame:** Winter 2024

Discussion, motion and possible action to approve a state contract with United Turf, an authorized vendor of Astroturf listed in the state contract for Artificial Turf for the infield and outfield of the girl's Softball field for the quoted price of \$570,000.



UNITED
TURF AND TRACK
PO BOX 565 ARCADIA, OK 73007
WWW.UNITEDTURFANDTRACK.COM



September 13, 2024

Mustang Public School
Robert Foreman, Director of Athletics
909 S. Mustang Rd
Mustang, OK 73064

Re: Mustang HS Softball Turf Project (091324) - **Sourcewell Contract #031622-AST**

Mr. Foreman,

Thank you for your interest in our products and services. We are pleased to present this proposal for your consideration. This proposal outlines the scope of work to be performed on the Mustang High School Softball Field. The proposal includes:

Softball Synthetic Construction, AstroTurf Diamond OPS Synthetic Grass Field:

1. Survey and Topographical Information
2. Geotechnical Engineering and Report
3. Civil Engineering, Design and Construction Documents
4. All project management, weekly job meetings, and mobilization.
5. Furnish all labor and equipment required for the earthwork scope of work. This shall include excavation, haul-off of the excess dirt materials, scarify, moisture condition and compaction of existing sub-grade. The softball field sub-grade shall be laser-graded at a minimum of .5% to a maximum of 1% to ensure positive drainage before field drainage system work begins. No topographical information or geotechnical information has been provided at this time. Construction testing shall be performed to include but not limited to proof-rolling with loaded tandem dump truck and a minimum of ten 95% compaction density shots. United Turf and Track will schedule and coordinate testing with selected testing company.
6. Furnish all materials, labor, and equipment to install a new 8"x12" perimeter concrete curb and curbing at the bullpens to accommodate two pitching lanes in the bullpens. Concrete curb shall contain two #5 rebar.
7. Furnish all materials, labor, and equipment to install a complete drainage system. This is to include 8", 10", 12", and 15" HDPE N-12 dual wall perforated and/or solid perimeter collector drains. The field drainage system shall tie into an existing storm water outflow pipe or daylight methods per plans.
8. Furnish all materials, labor, and equipment to install 4oz. separator fabric across the body of the field. Separator fabric shall be lapped and shingled 12" minimum with the planetary of the field and into the collector trenches.
9. Furnish all materials, labor, and equipment to install new composite 2x4 nail board at the concrete perimeter curb. Installation and attachment of nail board shall be by wedge style fasteners.
10. Furnish all materials, labor, and equipment to install a complete drainage stone sub-base, sloped per plan grades. A depth of 4.5" of #57 stone shall be installed and laser graded to .005 +/- of required planetary. A depth of 1.5" 3/8" #2 clean finish stone shall be installed, and laser graded to .0025 +/- of required planetary. Stone shall be rolled in for compaction as each lift is made.

11. Furnish all materials, labor, and installation equipment to install an AstroTurf artificial infilled grass system (+/- 44,880 SF). ALL turf, infill, AstroFusion Pro, seam tape, sewing thread, hot melt glue, 8-year non-prorated warranty and typical associated materials to complete the successful install shall be provided. Insert package is included for the Homeplate circle and pitching mound.
12. Furnish a new set Schutt Hollywood base anchors, home plates, bases, and pitching rubbers.

Total cost for Softball Synthetic Turf Scope of Work.....\$570,000.00

ALTERNATE ADD ITEMS:

ADD UPGRADE Foul Poles.....\$12,500.00
ADD UPGRADE Solid Metal Panel Outfield Fence System.....\$45,000.00

*****It is recommended that a Geotechnical Report be ordered to properly prepare the subgrade soils under the synthetic turf softball field based on the geotechnical engineer's recommendation*****

1. **Furnish all material, labor, and equipment to perform cement soil-stabilization for the turf field area. Soil-Stabilization shall extend 2' beyond the perimeter curb line..... \$62,941.00**

Inclusions:

- Payment & Performance Bonds
- Cooperative Contract Fee
- Samples, submittal information, and shop drawings as needed.
- Geotechnical Engineering and Report.
- Insurance as required.
- Mid-Outfield Logos
- Homeplate and/or Foul Territory Logos/Letters
- Inlaid markings as required for baseball and softball permanently installed in standard white synthetic turf.
- An infill of silca sand and SBR rubber at the manufacture-approved weights and ratios for the selected AstroTurf synthetic turf system.
- AstroTurf's Standard Eight (8) Year Warranty of the turf system materials.
- Clean-up and disposal of our debris into dumpsters.
- Wages as appropriate in the State of Oklahoma (non-prevailing/non-union)
- All colors are selected from AstroTurf's standard color palette.

Exclusions:

- **Sales and/or use Tax @ Mustang, OK. Sales Tax on materials will be billed in addition to the proposal price if tax exemption documentation is not provided.**
- Soil-Stabilization
- Fencing Work or Fence Modifications
- Poor Sub-Grade Remediation and/or Select Fill Material
- Any work not directly stated above.
- Any Liquidated Damages

Regards,



Dillon Ripley, CFB
 CEO
 United Turf and Track
 405-747-7748
unitedturfandtrack.com



October 7, 2024

Re: Artificial Turf and Tracks with Installation, Related Equipment, Materials and Supplies

To Whom it May Concern:

The AstroTurf response to Sourcewell's Request for Proposal (RFP) 031622 outlines on the contract Questions 26-28 that AstroTurf permits United Turf & Track to provide services on behalf of AstroTurf through the contract they hold with Sourcewell. United Turf & Track is a distributor for AstroTurf, they are authorized and incorporated into the contract as indicated in the language of the proposal as an authorized distributor.

Contract documentation linked below:

[AstroTurf: Contract 031622-AST | Sourcewell \(sourcewell-mn.gov\)](#)

Sincerely,

Heidi Murray | Senior Supplier Development Specialist

Office: 218-895-4119

Website: sourcewell-mn.gov





Schedule "A"
November 11, 2024

Employment				
Last Name	First Name	Replacing/New Position	Site/Assignment	Effective
Blackdeer-Deveni	Emily	James Neel	PVE/CN Full Time Cafeteria Assistant	11/04/2024
Dotson	Christy	Tammy Heldenbrand	Transportation/Bus Driver	11/01/2024
Glover	Melissa	Amberlynn Cornell	ME/Noon Supervisor	10/22/2024
Gutierrez	Karla	Karen Williams	MHS/CN Full Time Cafeteria Asst	10/28/2024
Harley	Robert	Jeremiah Thayer	Operations/Journeyman/Licensed Plumber	11/11/2024
Jobe	Brett	Maria Geikaunmah	Transportation/Bus Driver	11/04/2024
Jones	Latiah	Camilla Bolt	MCE/CN Full Time Cafeteria Asst	11/11/2024
King	Jennifer	Michael Gibson	Transportation/Bus Driver	11/04/2024
Laws	Tawny	Emily Brockett	MC/Teacher	12/02/2024
Malone	Darcie	Denise Horinek	MEC/Elementary Paraprofessional	10/22/2024
Ramirez	Andrew	Thearena Han	MBI/CN Full Time Cafeteria Assistant	11/04/2024
Ryan	Katelynn	New Position	ME/Spec Ed Para One on One	10/28/2024
Sanders	James	Brian Kidd	Transportation/Bus Driver	11/04/2024
Stow	Christopher	Xochitl Flores	LE/CN Full Time Floater	11/11/2024
Tilley	Barbara	Mary Moon	HZ/Teacher	11/11/2024
Trammell	Sandra	Kristen Matthews	MC/Noon Supervisor and Crossing Guard	11/08/2024
Reassignments				
Last Name	First Name	From: Site/Assignment	Site/Assignment	Effective
Bolt	Camille	MCE/CN Full Time Cafeteria Assistant	RWE/CN Full Time Cafeteria Assistant	11/04/2024
Mills	Angela	MERC/Central Enrollment Specialist	MERC/Exec. Admin. Asst. Fine Arts	10/28/2024
Resignations				
Last Name	First Name	From: Site/Assignment		Effective
Brockett	Emily	MC/Teacher		12/01/2024
Chacon Garcia	Concepcion	MBI/CN Full Time Cafeteria Assistant		11/04/2024
Matthews	Kristen	MC/MNMS/Noon Supervisor/Crosswalk		11/01/2024
McDonald	Gregory	Transportation/Bus Driver		11/19/2024
Moon	Mary	HZ/Teacher		11/08/2024
Parker	James	Operations/Custodian		10/22/2024
Thayer	Jeremiah	Operations/Journeyman Plumber		10/21/2024
Witte-Hunt	Joy	MNMS/ISI Supervisor		10/29/2024



Schedule "B"

November 11, 2024

Additional Duties				
Last Name	First Name	Assignment	Site	Effective
Ketch	Doug	Asst HS Boys Tennis	MHS	10/15/2024
McGill	Elizabeth	Asst MS Girls Track	MNMS	11/5/2024
McGill	Elizabeth	MS Multi Sport (2 Sports)	MNMS	11/5/2024
Trail	Monica	Homebound/based Services	District	2024-2025



Schedule "C"

November 11, 2024

Guest Teacher			
Last Name	First Name	Site/Assignment	Effective
Kuykendall	Troy	District	2024-2025
Siler	Michele	District	2024-2025
Soto	Angela	District	2024-2025
Wharry	Jami	District	2024-2025
Bronco Club 2024-2025 SY			
Last Name	First Name	Site	Effective
Brock	Karissa	MBI	2024-2025
Davis	Brooklyn	PVE	2024-2025
Griffin	Emma	CRI	2024-2025
Haskins	Emma	MV	2024-2025
Robertson	Tricia	MV	2024-2025
Wilson	Melissa	RWE	2024-2025