



AGENDA

Board of Education Regular Meeting

Monday, September 9, 2013 at 6:00 PM

Maxine and George Morris Alternative/Mustang Education Center 400 North
Clear Springs Road, Mustang, OK 73064, 12400 SW 15th St., Yukon,

Oklahoma 73099

As required by Section 311, Title 25 of the Oklahoma Statutes, notice is hereby given that the Board of Education of Independent School District Number I-069 of Canadian County, Oklahoma will hold a Board of Education Regular Meeting on Monday, September 9, 2013 at 6:00 PM. The place and street of the meeting will be Maxine and George Morris Alternative/Mustang Education Center 400 North Clear Springs Road, Mustang, OK 73064, 12400 SW 15th St., Yukon, Oklahoma 73099.

The Board of Education may discuss, make motions, and vote upon all matters appearing on this agenda. Such votes may be to approve, reject, table, reaffirm, rescind, or take no action on any agenda matter.

- A. Invocation and Flag Salute
- B. Roll Call (may be silent)
- C. Superintendent's Report
 - 1. Citizens of Character - Enthusiasm; being eager and excited to face new challenges.
 - 2. Board Correspondence
 - 3. Above & Beyond
 - 4. Groundbreaking for New Elementary - September 10, 2013 at 11:00 a.m. at intersection of County Line and 59th Street, Mustang, OK.
 - 5. Mustang Valley Outdoor Classroom Project
 - 6. Presentation by: MA+ Architecture's
 - a. The Board will consider and may take action to approve the MA+ Architecture's schematic design for the new high school event center.
- D. Board Reports
- E. Standing and Financial Resolutions

1. Chief Financial Officer Report - Deanna Mowrey
 - a. Vote to approve or not approve the Schedule of Encumbrances and Monthly Financial Reports:

F. Public Participation

G. Consent Agenda

1. Board of Education Minutes:
 - a. August 12, 2013 Regular Business meeting
2. Activity Accounts:
 - a. Transfer of \$978.95 from Valley Activity Account #841 to Valley PE Activity Account #998.
3. Acceptance of Donation:
 - a. Donation of \$2,500.00 from IPS Engineering of Oklahoma City to the MHS Robotics Club. The funds will be put in Acct#940 and used for tournament dues, robotic parts, robotic equipment, food and refreshments.
4. Approval of Surplus list from MHS Band Department.
5. Approval of Surplus list from Child Nutrition.
6. Out-of-District Overnight Travel:
 - a. Approval of JROTC to attend the Top of Texas Team Competition in Wichita Falls, Texas on October 5, 2013.
 - b. Approval for three (3) administrators- Geromy Schrick, Deanna Mowrey and Carol Wood to attend the ALIO Conference, October 15-16, 2013 in Tempe, AZ. Alio is the new software program for finance and personnel.
 - c. Approval for Title I Reading teachers, Title I Math teachers, Director of Federal Programs to attend the Title I National Conference, February 2-5, 2014 in San Diego, California. All expenses will be paid with Title I, Project 511 Funds.
 - d. Approval of four (4) intermediate teachers to attend the International STEM Educators Association (ISEA) Conference in Branson, Missouri October 6-8th, 2013.

7. Use of Facilities:
 - a. OK Storm Volleyball Club is requesting the use of MMS Gym for practices for their club volleyball program for the Mustang area. They will need the gym every Tues/Thurs from 6:00-9:00 p.m. Oct 8- April 30, 2014. Purpose is to teach fundamentals and the game of volleyball to girls ages 10-17.
 - b. Latchkey Child Services, Inc. is requesting the use of multiple facilities to provide supervised activities during out of school time during the 2013-2014 school year. Requesting the use of cafeterias at Valley/Creek/TE/ME/Horizon and Canyon Ridge 6:30-8:00 am,& 2:30-6:30 pm on a daily basis on school days.
 - c. Lakehoma/Centennial After School Program is requesting the use of the cafeterias at two sites for their child care activities. Requesting facilities from 6:30-7:30 am & 2:50-6:30 pm on a daily basis on school days.
 - d. Oklahoma Mustangs basketball team is requesting use of Creek Elem gym for practices. Sponsor is Gerry Hunt. Starting Sept 15-Oct 27th on Sundays from 2:00-3:30 p.m. Horizon's main gym Nov. 5-Feb. 27th on Tues/Thurs from 6:00-8:30 p.m.
8. Renewal of continued agreement with Oklahoma State Department of Health to utilize the Oklahoma State Immunization Information System (OSIIS) for SY 2013-2014
9. Approval of revisions to the following Policy and Procedures:
 - a. Use of Facilities, #2030
10. Approval of participation of an on-site dance instruction/therapy program for the students enrolled in the PASS program. Funds received from Oklahoma Arts Council (\$2,475.00) and MHS Pass Activity Acct#901 for \$275 payable to Todd Wisdom, artist.
11. Approval of participation in a Mini Math and Science Partnership Grant - titled Leading by Example for Engineering Design (LEED). The grant amount (\$58,476.23) is funded through the Oklahoma State Department of Education to be shared by six (6) districts.
12. Approval of after school program for ELL (English Language Learners)/Immigrant students and parents. This includes hiring of coordinators/tutors at two sites, one elementary and one secondary. All costs of program will be paid with Title III Funds. Estimated costs are \$15,000.00.
13. Approval of revised Nurse's Assistant job description.

14. Approval of the District Gifted Plan for SY 2013-2014.
15. Approval of recommendation for a 180 day school year, which includes two (2) parent teacher conference days and five(5)PD days, with the flexibility to exercise the 1080 hours calendar option in case of school closures due to inclement weather or other catastrophic circumstances for SY 2013-2014.
16. Approval of certificate of substantial completion for Horizon Intermediate.
17. Approval of Timberlake Change Order #11 for school on Sara Road. This will be a total decrease to the Construction Contingency by \$25,861.35.
18. Approval of Change Order #8 for Horizon Intermediate (Midhigh Renovation) This will be a net decrease to the contingency of \$10,475.00.
19. Approval of Change order #1 for County Line Elementary, this will be a net decrease to the contingency of \$18,837.00.
20. Approval of the Right of Way Easements to the City of Oklahoma City for County Line Elementary.

H. Business

1. Capital Improvements Committee/2013 Bond presentation
 - a. The Board will discuss, consider and/or act upon approving a resolution authorizing the calling and holding of a special election to be held in this School District to authorize the issuance of general obligation bonds, and setting forth the following items:
 - b. The Board will consider and may take action to call for a bond election to be held November 12, 2013 in the amount of 4.8 million.
2. The Board will consider and may take action to approve the contract with Robin Howard to provide Speech Pathology services for SY 2013-2014.
3. The Board will discuss, consider and/or act to approve the selection of BOSC, Inc., a subsidiary of BOK Financial Corporation, to act as financial advisor in connection with the proposed General Obligation bonds.
4. The Board will consider and may take action to approve the high bid or to reject all bids for the 60 acres located at 44th & Czech Hall Rd.
5. The Board will consider and may take action to approve the MAPS request for purchase of property.

6. The Board will consider and may take action to approve low bids from Ross Transportation to include: 1) 77 passenger bus for \$83,901.00 1) 53 passenger bus with lift for \$94,926.00
 7. The Board will consider and may take action to approve the Estimate of Needs for 2013-2014 school year.
- I. New Business:
 - J. Executive Session The Board of Education will consider and may vote to convene in Executive Session.
 1. Oklahoma Statutes Title 25, § Section 307(B)(1): Discuss employment, hiring, appointment, promotion, demotion, disciplining, or resignation of an employee.
 - a. Schedule "A"
 - b. Schedule "B"
 2. Oklahoma Statutes Title 25, § 307(B) (3): Discussing the purchase or appraisal of real property.
 - K. Acknowledge Return to Open Session
 - L. Statement of Executive Session by Board Clerk
 - M. Vote to approve or not approve the Superintendent's Recommendation concerning employment as listed on Schedule "A".
 - N. Vote to approve or not approve the Superintendent's Recommendation concerning employment as listed on Schedule "B".
 - O. The Board will consider and may take action to approve the purchase contract and settlement statement with the property owners of 921 Snyder in Mustang, Oklahoma.
 - P. Adjournment.

NEW EVENT CENTER

ENTRY FACING NW
ENTRY PLAZA

FUTURE GROWTH

ADDITIONS TO THE WEST

SITE IMPROVEMENTS

BUILDING DROP OFF
37 NEW PARKING STALLS
4 NEW BUS STALLS
SERVICE DRIVE FOR BLDG
ACCESS-TENNIS COURTS
LANDSCAPING

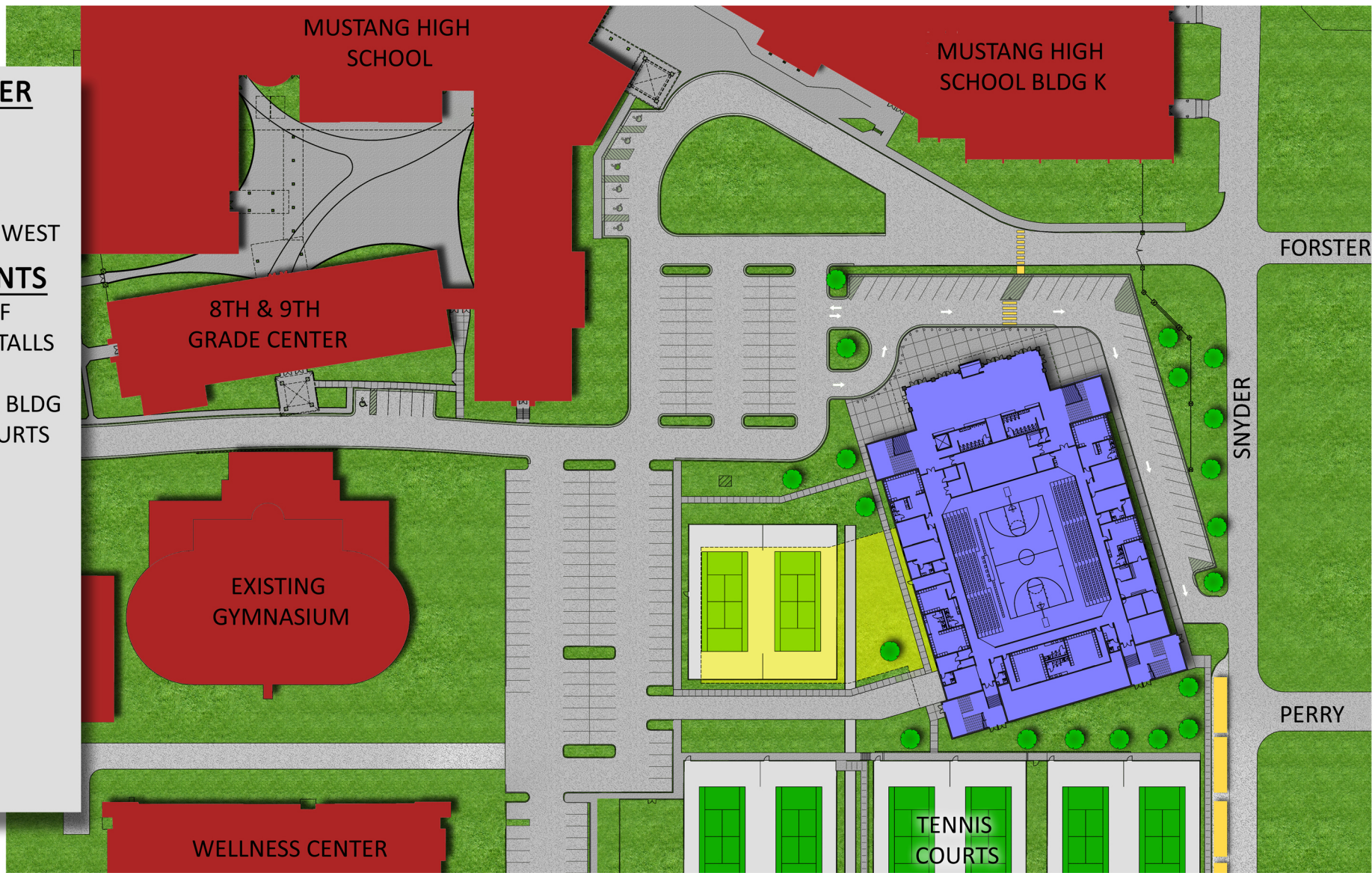

MUSTANG HIGH SCHOOL EVENT CENTER

MA+ architecture



LOCKER ROOMS

- BOYS VARSITY
- GIRLS VARSITY
- BOYS JR VARSITY
- GIRLS JR VARSITY
- 2 VOLLEYBALL/TENNIS
- 2 OFFICIALS LOCKER RM

EVENT ROOM

- SEATING FOR 60
- SPECIAL EVENTS
- DONOR SEATING

ENTRY LOBBY

- TROPHY CASES
- TICKET BOOTH
- MUSTANG LOGO

FILM ROOMS

TRAINING ROOM

COACHES OFFICES

RETRACTABLE SEATING

LAUNDRY ROOMS

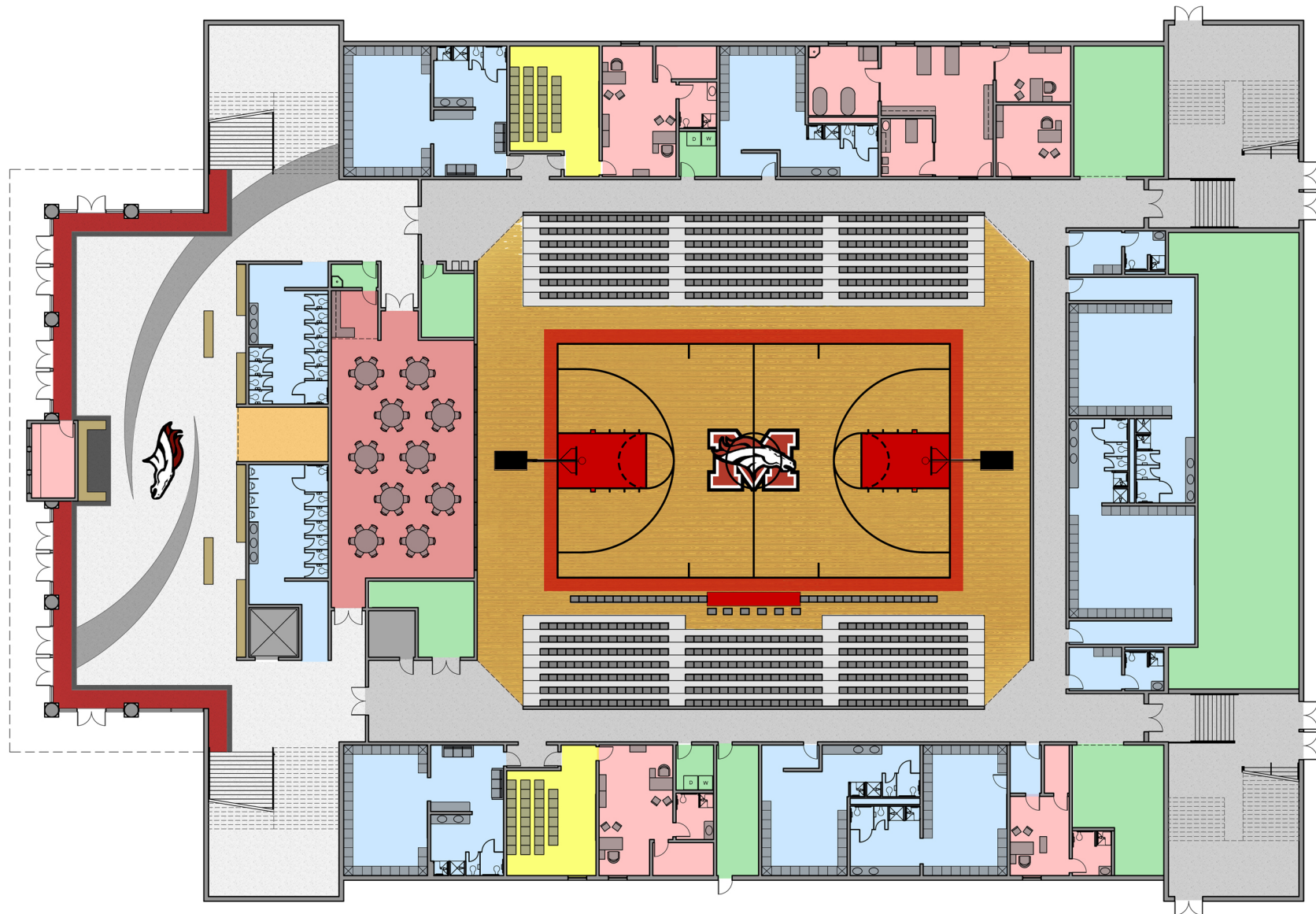

MUSTANG HIGH SCHOOL EVENT CENTER

MA+ architecture

OFFICES

- 5 OFFICES
- CONFERENCE ROOM
- STORAGE ROOM

CONCESSIONS

- 2 CONCESSIONS AREAS

SEATING

- LOWER LEVEL: 628
- UPPER LEVEL: 1,872
- TOTAL SEATING EST: 2,500

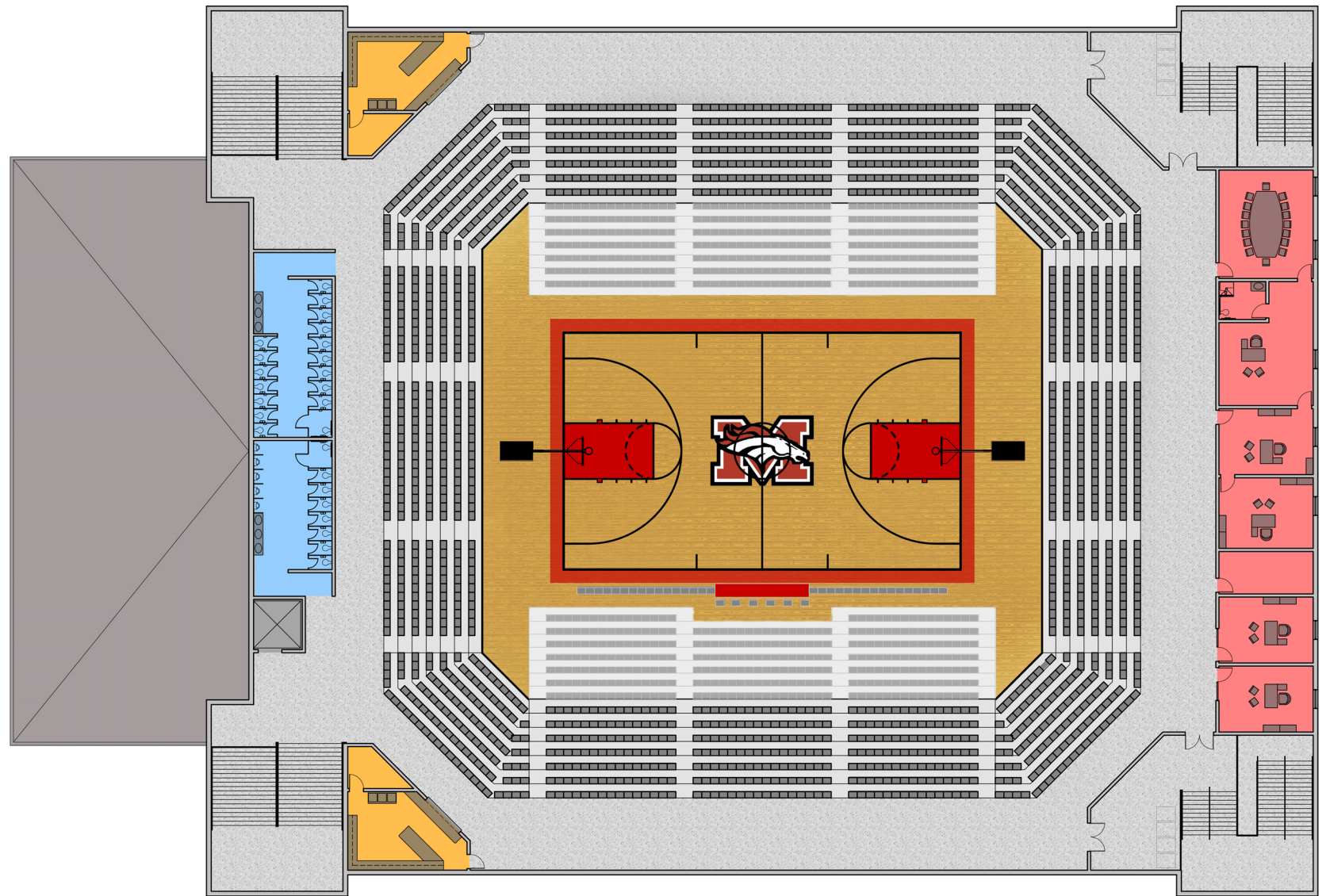

MUSTANG HIGH SCHOOL EVENT CENTER

MA+ architecture



2012



2011



2010



2010



2010



2010



MUSTANG HIGH SCHOOL EVENT CENTER

MA+ architecture



MUSTANG HIGH SCHOOL EVENT CENTER

MA+ architecture



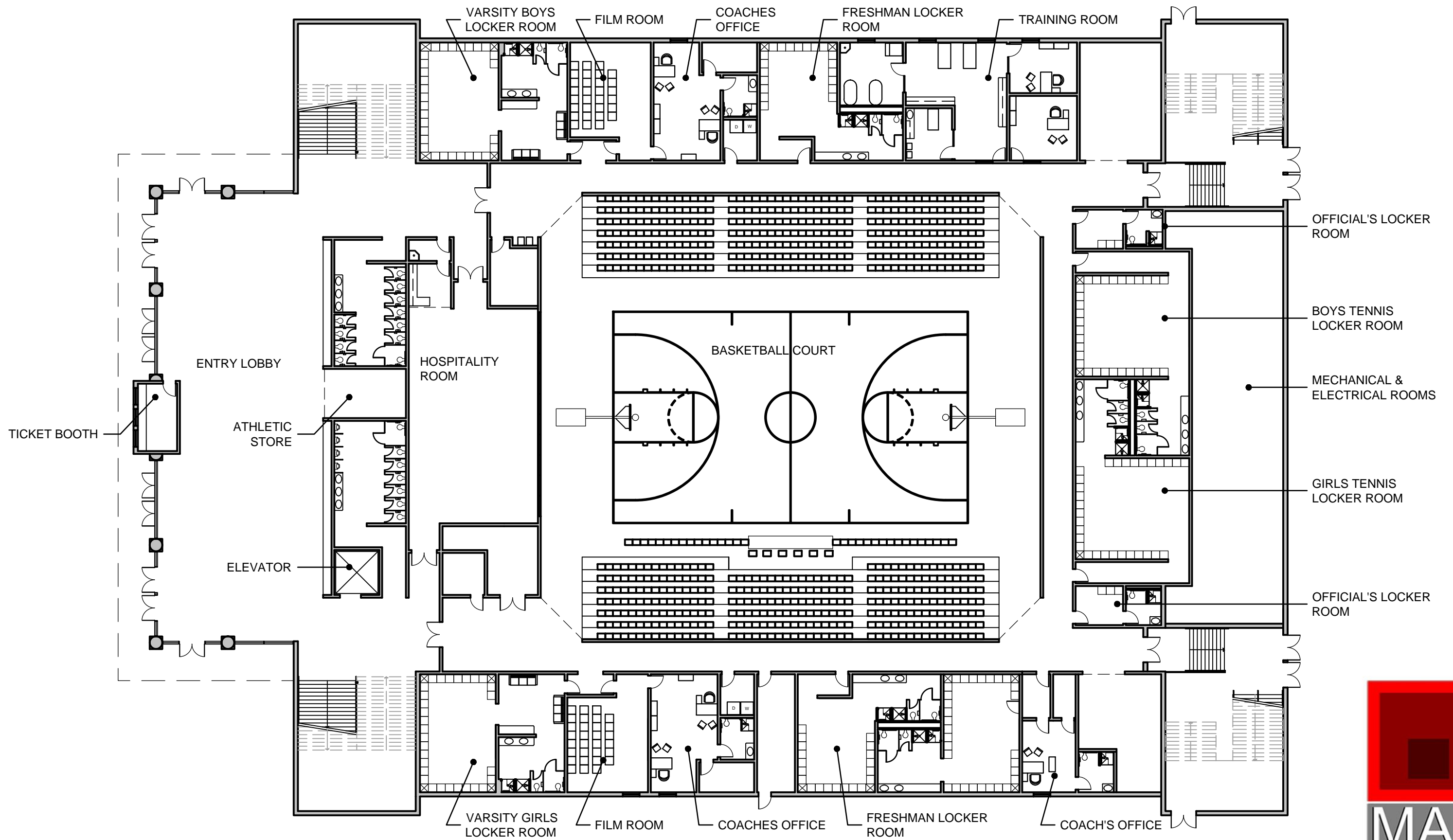

1ST FLOOR PLAN
NOT TO SCALE



MUSTANG EVENT CENTER

MA+ Architecture, L.L.C.
4000 N. Classen Blvd, Suite 100N, Oklahoma City, OK 73118

phone: 405.525.8806 fax: 405.525.8807 www.maplusarchitecture.com

date: AUG 26, 2013

This drawing and the design shown are the property of MA+ Architecture, L.L.C. The reproduction, copying, or other use of this drawing without written consent is prohibited and any infringement will be subject to legal action. ©2013 MA+ Architecture

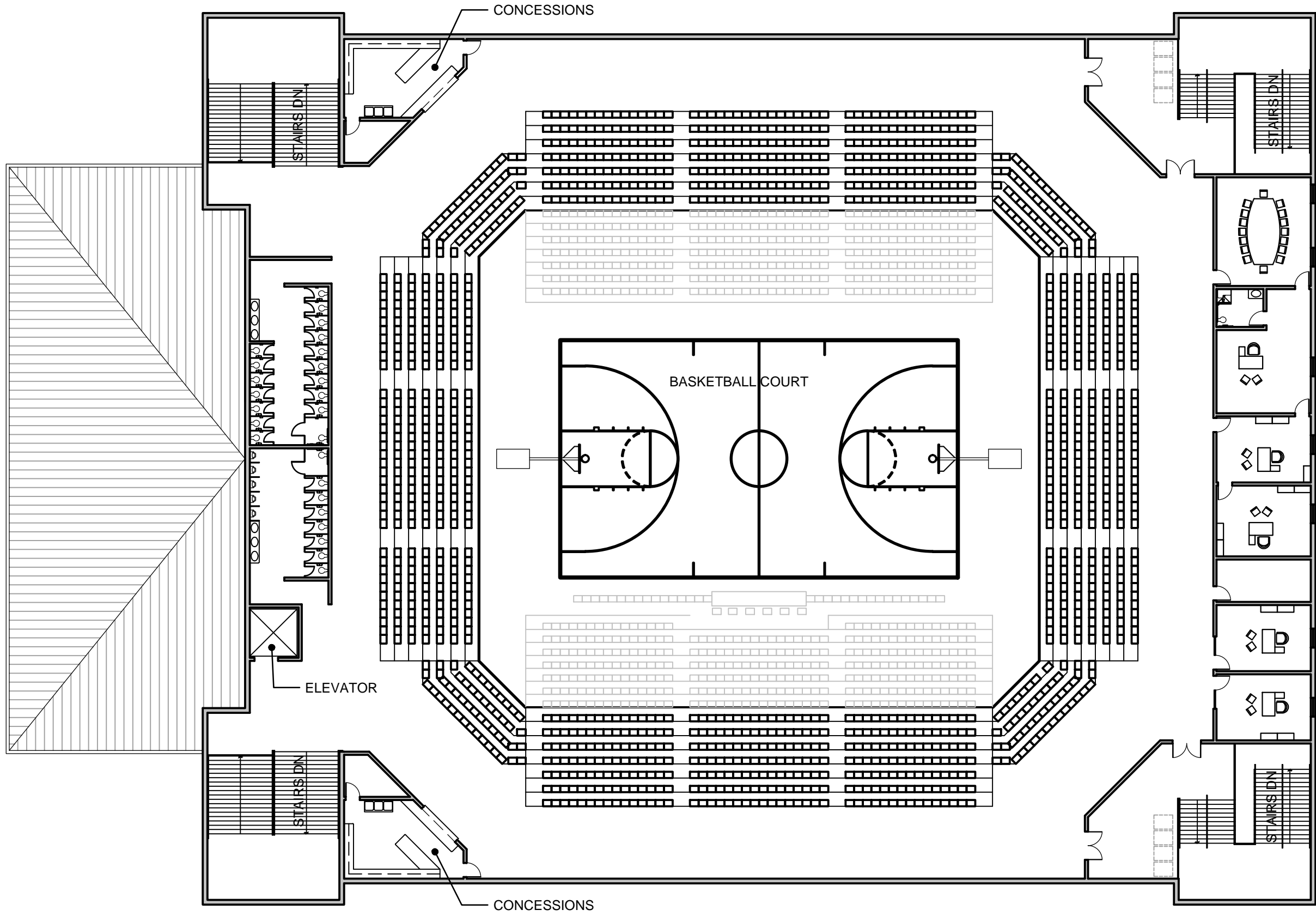

BUILDING TOTALS:
 LOWER LVL SEATING: 628
 UPPER LVL SEATING: 1,384
TOTAL SEATING: 2,012

1ST FLR AREA: 46,844 SF
 2ND FLR AREA: 29,763 SF
TOTAL AREA: 76,607SF

ATHLETIC DEPARTMENT OFFICES

2ND FLOOR PLAN
 NOT TO SCALE

MUSTANG EVENT CENTER

MA+ Architecture, L.L.C.
 4000 N. Classen Blvd, Suite 100N, Oklahoma City, OK 73118

phone: 405.525.8806 fax: 405.525.8807 www.maplusarchitecture.com

date: AUG 26, 2013

This drawing and the design shown are the property of MA+ Architecture, L.L.C. The reproduction, copying, or other use of this drawing without written consent is prohibited and any infringement will be subject to legal action. ©2013 MA+ Architecture



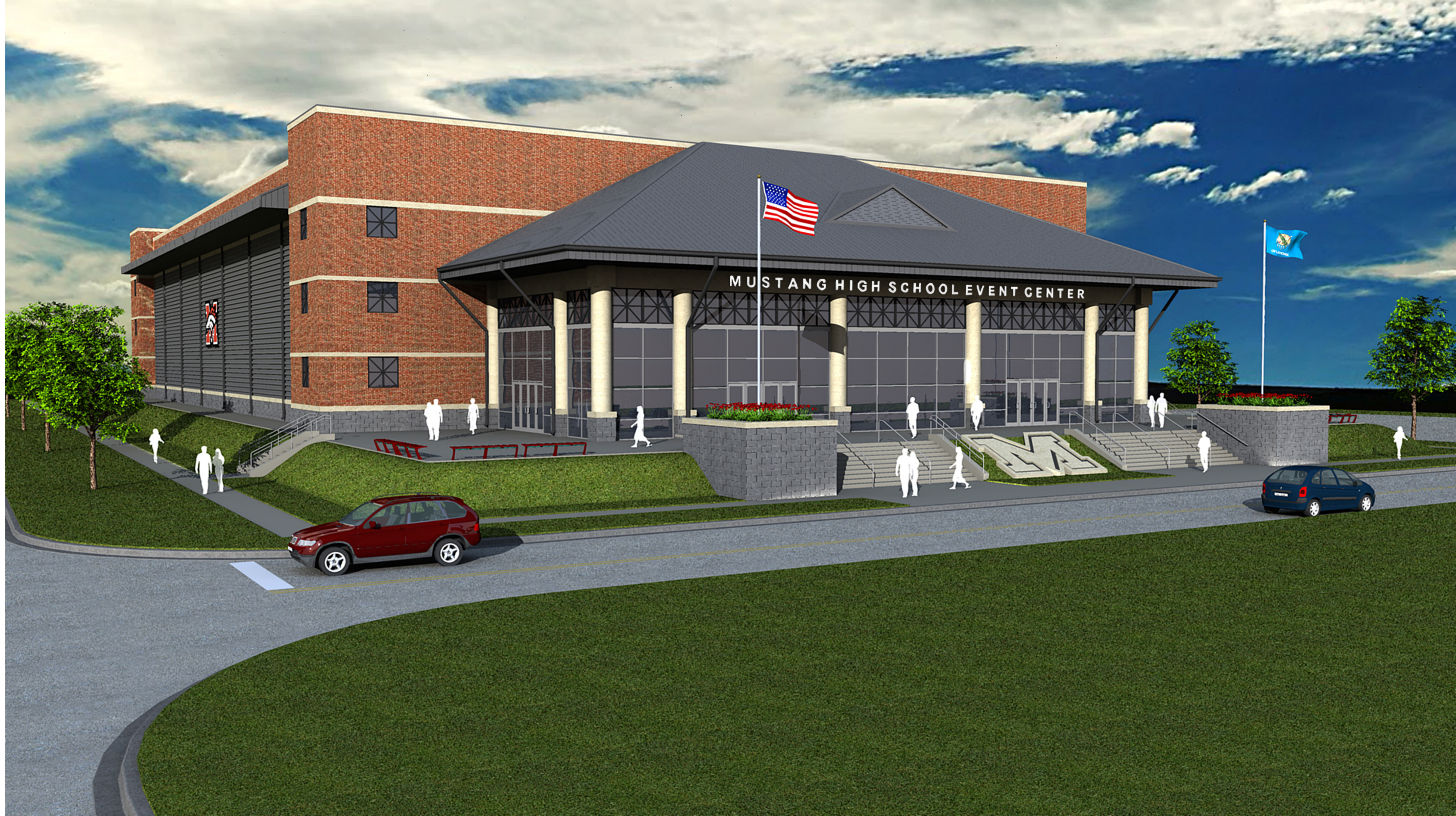

MUSTANG HIGH SCHOOL NEW EVENT CENTER

MUSTANG PUBLIC SCHOOLS



SEPTEMBER 9, 2013 BOARD MEETING

FISCAL YEAR 2014

PAYROLL

LEASE REVENUE BOND (10)	77-105	
GENERAL FUND (11)	519-839	50377-50633
BUILDING FUND (21)	23-30 (PO 22 WAS CLOSED – NOT USED)	
FOOD SERVICE (22)	138-174	50007-50021
LEASE REVENUE BOND (23)		.
OKC MAPS TRUST (24)		
BOND FUND (31)	2	
BOND FUND (32)	3	
BOND FUND (33)	10	
BOND FUND (34)	9	
BOND FUND (35)	11-12	
BOND FUND (36)	31	
BOND FUND (37)	24-42	
BOND FUND (38)		
BOND FUND (39)		.

LSE REVENUE ISS 2012 2013-2014
Summary Change Order Listing
As of 09/04/2013

P.O. No.	Date	To Whom Issued	P.O. Description	Amount
37	07/01/2013	WEST MUSIC	ROLLOVER 2013-10-63	-2.50
46	07/01/2013	WEST MUSIC	ROLLOVER 2013-10-73	-3.00
52	07/01/2013	SCHOOL OUTFITTERS	ROLLOVER 2013-10-80	59.92
53	07/01/2013	SCHOOL OUTFITTERS	ROLLOVER 2013-10-81	59.92
71	07/16/2013	UNITED REFRIGERATION, INC.	171 ICE MACHINE 4 C.R. KITCHEN	20.00
72	07/22/2013	GRAINGER	171 KEY BOXES	11.16
76	07/25/2013	CENTRAL OKLAHOMA TURF	172 SOD FOR HORIZON	40.00
Total Change Orders				185.50

LSE REVENUE ISS 2012 2013-2014
Detail Encumbrance Listing
As of 09/04/2013

PurOrder	Date	To Whom Issued / Detail Description	Po Description / Classification	
77	08/09/2013	BEST COMPANIES	171 LOCKERS 4 CAFETERIA	
		(12) 12"X72" LOCKERS W/BUILT IN LOCKS FOR CAFETERIA WORKERS	171-2620-654-000-0000-000-145	1,625.00
Total Purchase Order				1,625.00
78	08/13/2013	APPLE INC.	171 TECHNOLOGY	
		APPLE TV	171-1000-653-100-0000-000-145	5,346.00
Total Purchase Order				5,346.00
79	08/13/2013	APPLE INC.	172 TECHNOLOGY	
		APPLE TV	172-1000-653-100-0000-000-140	3,960.00
Total Purchase Order				3,960.00
80	08/13/2013	B&H PHOTO/VIDEO	172 TECHNOLOGY	
		PowerLite X12 Multimedia Projector	172-1000-653-100-0000-000-140	829.26
Total Purchase Order				829.26
81	08/13/2013	B&H PHOTO/VIDEO	171 TECHNOLOGY	
		PowerLite X12 Multimedia Projector	171-1000-653-100-0000-000-145	829.26
Total Purchase Order				829.26
82	08/13/2013	CHICKASAW TELECOM	171 TECHNOLOGY	
		APC 2200VA/1600 WATT EXPANDABLE UPS 6 OUT	171-2580-530-000-0000-000-145	1,179.21
		APC 48V BATTERY PACK	171-2580-530-000-0000-000-145	476.70
		APC 1KVA/800W LCD R EXPANDABLE SINEWAVE	171-2580-530-000-0000-000-145	581.85
		APC 48V EXTERNAL BAT 2U RACK MOUNT	171-2580-530-000-0000-000-145	488.65
		APC 1KVA/800W LCD R EXPANDABLE SINEWAVE	171-2580-530-000-0000-000-145	581.85
		APC 48V EXTERNAL BAT 2U RACK MOUNT	171-2580-530-000-0000-000-145	488.65
		APC 1KVA/800W LCD R EXPANDABLE SINEWAVE	171-2580-530-000-0000-000-145	581.85
		APC 48V EXTERNAL BAT 2U RACK MOUNT	171-2580-530-000-0000-000-145	488.65
Total Purchase Order				4,867.41
83	08/13/2013	TWOTREES TECHNOLOGIES	171TECHNOLOGY	
		HP LASERJET PRO 400 M401dw-B/W PRINTER - MONO PPM	171-1000-653-100-0000-000-145	850.00
		USB - 802.11b/g - 300 SHEETS	171-1000-653-100-0000-000-145	4,250.00
Total Purchase Order				5,100.00
84	08/13/2013	TWOTREES TECHNOLOGIES	172 TECHNOLOGY	
		HP LASERJET PROO 400 M401dw - B/W PRINTER - MONO PPM	172-1000-653-100-0000-000-140	4,250.00
		USB - 802.11b/g - 300 SHEETS		
Total Purchase Order				4,250.00
85	08/13/2013	FIVE STAR FENCE	172 FENCE 4 SIDEWALK @ HORIZON	
		FENCE FOR SIDEWALK AT HORIZON	172-2630-459-000-0000-000-140	2,214.00
			172-2630-459-000-0000-000-140	426.00
Total Purchase Order				2,640.00
86	08/13/2013	OLDHAM ACRES LANDSCAPING, INC.	172 LANDSCAPE FOR HORIZON	
		N.W. ENTRY AND WEST ENTRY BEDS	172-2630-459-000-0000-000-140	3,193.00
Total Purchase Order				3,193.00
87	08/13/2013	SCHOOL OUTFITTERS	171 WHITE BOARD FOR C.R. FLEX	
		(8) WHITE BOARDS WITH MAP RAIL AND ALUMINUM FRAME FOR FLEX ROOMS	171-2620-654-000-0000-000-140	2,552.00
Total Purchase Order				2,552.00
88	08/13/2013	OFFICE DEPOT	171 PAPER CUTTER/SHREDDER	
		PAPER CUTTERS	171-2620-655-000-0000-000-145	405.84
		PAPER SHREDDERS	171-2620-651-000-0000-000-145	479.98

LSE REVENUE ISS 2012 2013-2014
Detail Encumbrance Listing
As of 09/04/2013

PurOrder	Date	To Whom Issued / Detail Description	Po Description / Classification	
88	08/13/2013	OFFICE DEPOT	171 PAPER CUTTER/SHREDDER	
100	BOSTITCH	ELECTRI PENCIL SHARPENERS	171-2620-654-000-0000-000-145	2,099.00
Total Purchase Order				2,984.82
89	08/14/2013	CDW GOVERNMENT, INC.	171 TVS FOR PRINCIPALS	
(3)	32"	TV'S FOR PRINCIPALS AND OFFICE CHECK IN	171-2620-653-000-0000-000-140	709.44
Total Purchase Order				709.44
90	08/16/2013	MULLIN PLUMBING WEST DIVISION, INC.	172 INSTALL SINKS AT HZN GYM	
INSTALL 4 SINKS AND FAUCETS IN MENS AND WOMENS RESTROOMS NEXT TO GYM (WILL PROVIDE P-TRAPS AND SUPPLY LINES)			172-2620-457-000-0000-000-140	375.00
Total Purchase Order				375.00
91	08/20/2013	DECKER EQUIPMENT	171 BIKE RACKS 4 C.R.	
(6)	5 LOOP	BIKE RACKS, BLACK BD57	171-2630-654-000-0000-000-145	2,587.68
SHIPPING			171-2630-654-000-0000-000-145	271.01
Total Purchase Order				2,858.69
92	08/22/2013	BUDGET FLAG & BANNER	172 OUTSIDE FLAGS	
(1)	4X6	AMERICAN FLAG	172-2620-654-000-0000-000-140	45.00
(1)	3X5	OKLAHOMA FLAG	172-2620-654-000-0000-000-140	27.00
Total Purchase Order				72.00
93	08/22/2013	OLDHAM ACRES LANDSCAPING, INC.	172 LANDSCAPE AT HORIZON	
LANDSCAPE AT WEST ENTRY ISLAND BEDS - 2			172-2630-459-000-0000-000-140	589.50
EAST ENTRY - TREE WELL			172-2630-459-000-0000-000-140	92.00
NORTH SIDE BLDG. BED			172-2630-459-000-0000-000-140	148.00
Total Purchase Order				829.50
94	08/22/2013	THOMPSON EDUCATIONAL FURNISHINGS	171 CONFERENCE TABLE	
(1)	HON	CONFERENCE TABLE, HTLB4896, BOAT SHAPE, SHAKER CHERRY	171-2620-654-000-0000-000-145	833.03
(1)	HON	CURVED PANEL BASE FOR CONF TABLE, HTLC96, SHAKER CHERRY	171-2620-654-000-0000-000-145	296.30
Total Purchase Order				1,129.33
95	08/26/2013	THOMPSON EDUCATIONAL FURNISHINGS	172 INSIDE BENCHES 4 HZN	
(4)	HIGH POINT	METAL BENCHES, 918MET	172-2620-654-000-0000-000-140	2,800.00
Total Purchase Order				2,800.00
96	08/26/2013	THOMPSON EDUCATIONAL FURNISHINGS	171 INSIDE BENCHES 4 C.R.	
(4)	HIGH POINT	METAL BENCHES, 918MET	171-2620-654-000-0000-000-145	2,800.00
Total Purchase Order				2,800.00
97	08/28/2013	BARCO PRODUCTS	172 TRASH RECEPTACLES/BENCHES	
(6)	PUP942SMBPR8,	BACKLESS BENCHES, 8' BLACK	172-2620-654-000-0000-000-140	2,474.82
(5)	PUPEX-32,	TRASH RECEPTACLE, 32GALLON, BLACK	172-2620-654-000-0000-000-140	1,316.35
(5)	PUPRBR-3208,	STEEL TOPS FOR RECEPTACLES, BLACK	172-2620-654-000-0000-000-140	651.80
(5)	PUPPL-32,	PLASTIC LINERS FOR RECEPTACLES, BLACK	172-2620-654-000-0000-000-140	217.90
SHIPPING			172-2620-654-000-0000-000-140	345.97
Total Purchase Order				5,006.84
98	08/28/2013	BARCO PRODUCTS	171 TRASH RECEPTACLES/BENCHES	
(6)	KBM1330	BACKLESS BENCHES, 6', CEDAR/BLACK	171-2620-654-000-0000-000-145	1,493.42
(4)	KTR1135,	33 GALLON TOP LOAD WASTE RECEPTACLES, CEDAR/BLACK	171-2620-654-000-0000-000-145	1,553.72
SHIPPING			171-2620-654-000-0000-000-145	345.97

LSE REVENUE ISS 2012 2013-2014
Detail Encumbrance Listing
As of 09/04/2013

PurOrder	Date	To Whom Issued / Detail Description	Po Description / Classification	
98	08/28/2013	BARCO PRODUCTS	171 TRASH RECEPTACLES/BENCHES	
			Total Purchase Order	3,391.11
99	08/28/2013	TIMBERLAKE CONSTRUCTION	171 ADDED BOOK CASES	
		ADDED BOOK CASES AT C. R. MEDIA	171-2620-654-000-0000-000-145	6,159.00
			Total Purchase Order	6,159.00
100	08/29/2013	BUDGET FLAG & BANNER	171 FLAGS 4 CLASSROOMS	
		(24) OKLAHOMA FLAGS, 12"X18"	171-2620-654-000-0000-000-145	36.00
		(24) AMERICAN FLAGS, 12"X18"	171-2620-654-000-0000-000-145	29.28
			Total Purchase Order	65.28
101	08/29/2013	THOMPSON EDUCATIONAL FURNISHINGS	171 BOOK SHELVES 4 OFFICES	
		(3) HON BOOK SHELVES, H10534.FF, SHAKER CHERRY	171-2620-654-000-0000-000-145	907.50
			Total Purchase Order	907.50
102	08/30/2013	OLDHAM ACRES LANDSCAPING, INC.	171 SOUTH/EAST ENTRY LANDSCAPE	
		SOUTH ENTRY LANDSCAPE	171-2630-459-000-0000-000-145	1,638.50
		EASTY ENTRY LANDSCAPE	171-2630-459-000-0000-000-145	610.50
			Total Purchase Order	2,249.00
103	09/04/2013	CDW GOVERNMENT, INC.	172 TECHNOLOGY	
		StarTech.com 3 ft High Speed HDMIr Cable - HDMI to HDMI - M/M	172-1000-653-000-0000-000-140	269.00
			Total Purchase Order	269.00
104	09/04/2013	CDW GOVERNMENT, INC.	171 TECHNOLOGY	
		StarTech.com 3 ft High Speed HDMIr Cable - HDMI to HDMI - M/M	171-1000-653-000-0000-000-145	269.00
			Total Purchase Order	269.00
105	09/04/2013	CDW GOVERNMENT, INC.	171 TECHNOLOGY	
		Cyber Acoustics AC 100b - headset	171-1000-653-000-0000-000-145	825.00
			Total Purchase Order	825.00
			Total Fund	68,892.44

DateAdded	PurOrder	PoVendor	Description	ExPrice
08/15/2013	20	FORD AUDIO	055 INC PO 11-20 FOR THE REPAIR/SERIVE ON THE HI	261.51
09/04/2013	242	DAVID STANLEY C	INCREASE DUE TO SHORTAGE ON ESTIMATE	946.58
08/09/2013	501	DICK BLICK CENT	PRICE INCREASE FOR PO # 501	140.00

\$1348.09

Pij	Func	Obj	Prg	Subj	Jcl	Unl	Classified	CertificationNo	Payment	icType	icCode	PayVendorNo	BegDate	Er
000	2620	438	000	0000	000	055	261.51	361621				11351	07/01/2013	

General Fund 2013-2014
Summary Change Order Listing
As of 09/04/2013

P.O. No.	Date	To Whom Issued	P.O. Description	Amount
89	07/01/2013	LINKS LAWN EQUIPMENT	054 LAWN PARTS	6.18
173	07/08/2013	DALE ROGERS TRAINING CENTER, INC.	183 JULY ESY REGISTRATION	-290.00
188	07/08/2013	GRAINGER	063 806 GIRLS BB EQUIPMENT	0.90
195	07/15/2013	OFFICE DEPOT	050 051 OFFICE SUPPLY	-1.10
210	07/15/2013	OFFICE DEPOT	OFFICE SUPPLIES	-5.12
215	07/15/2013	WILLIAM KEVIN BACK	412 505 REIMBURSEMENT	27.35
216	07/15/2013	ARCHWAY MARKETING SERVICES	333 110 VALLEY - TEXTBOOKS	-137.55
217	07/15/2013	ARCHWAY MARKETING SERVICES	333 120TRAILS ELEM - TEXTBOOKS	-167.25
218	07/15/2013	ARCHWAY MARKETING SERVICES	333 125 CREEK - TEXTBOOKS	-126.81
219	07/15/2013	ARCHWAY MARKETING SERVICES	333 135 CENTENNIAL - TEXTBOOKS	-94.56
220	07/15/2013	ARCHWAY MARKETING SERVICES	333 705HIGH SCHOOL - TEXTBOOKS	-3.97
222	07/15/2013	BARNES & NOBLE	333 705HIGH SCHOOL - TEXTBOOKS	-370.33
226	07/15/2013	THOMPSON SCHOOL BK.DEPOSITORY	333 120TRAILS ELEM - TEXTBOOKS	-48.68
227	07/15/2013	THOMPSON SCHOOL BK.DEPOSITORY	333 115LAKEHOMA ELEM TEXTBOOK	-32.40
229	07/15/2013	THOMPSON SCHOOL BK.DEPOSITORY	333 110 VALLEY - TEXTBOOKS	-41.85
230	07/15/2013	THOMPSON SCHOOL BK.DEPOSITORY	333 125 CREEK - TEXTBOOKS	-36.45
242	07/15/2013	DAVID STANLEY	054 VEH MAINT SERVICE	946.58
247	07/15/2013	AMSAN EVE SUPPLY	057 CUSTODIAL SUPPLIES	-9.44
252	07/15/2013	CANADIAN COUNTY SHERIFF OFFICE	050 LAW ENFORCEMENT-NORTH	-5,384.75
260	07/15/2013	ROGER BURNETT	050 SECURITY	-25.00
332	07/16/2013	RIVERSIDE PUBLISHING	059 PYSCHS/LAKEHOMA	-222.20
335	07/16/2013	WEB RESOURCE LLC	059 SP ED TRAILS	11.97
340	07/16/2013	CDW GOVERNMENT, INC.	059 CASES FOR PSYCHS	-22.28
345	07/16/2013	CITY OF MUSTANG	050 LAW ENFORCEMENT 2013-2014	-40,840.00
352	07/16/2013	OFFICE DEPOT	000 066 DIRECTOR SUPPLIES	-106.92
363	07/18/2013	SCHOOL SPECIALTY	510 SCHOOL SPECIALTY	28.00
364	07/18/2013	TARGET BANK - ACCNT ID 00028951373	510 CLASSROOM SUPPLIES	-4.05
376	07/18/2013	STAPLES BUSINESS ADVANTAGE 156121:	CLASSROOM SUPPLIES	75.00
381	07/22/2013	ZEE SERVICE COMPANY	412 705 FIRST AIDE	2.60
383	07/22/2013	KAREN WOODARD	412 705 CONFERENCE REIMBUR	-90.79
385	07/22/2013	JENNIFER E MANGUS	412 705 CONF REIMB.	-292.79
389	07/22/2013	QUILL	135 OFFICE SUPPLIES	12.14
392	07/22/2013	POSITIVE PROMOTIONS ATTN. ACCTS RE	110 CLASSROOM/TECH INSTRUCTIC	-2.22
405	07/24/2013	MULLIN PLUMBING WEST DIVISION, INC.	055 PLUMBING SERVICES	-40.75
407	07/24/2013	OFFICE DEPOT	510 MNMS CARDSTOCK PAPER	-3.60
409	07/24/2013	CIMC	412 705 Instruction	37.40

General Fund 2013-2014
 Summary Change Order Listing
 As of 09/04/2013

P.O. No.	Date	To Whom Issued	P.O. Description	Amount
429	07/24/2013	DISCOUNT SCHOOL SUPPLY	510 MNMS BUTCHER PAPER ROLLS	-27.18
437	07/24/2013	CDW GOVERNMENT, INC.	K20/OETT GRANT PURCHASES	-21.02
440	07/25/2013	VETS PLUMBING	055 PLUMBING SERVICES	-250.00
444	07/26/2013	ARCHWAY MARKETING SERVICES	333 705 HIGH SCHOOL TEXTBOOKS	-1.98
449	07/26/2013	CENGAGE LEARNING/GALE	333 705 HIGH SCHOOL TEXTBOOKS	-210.26
451	07/26/2013	PEARSON	333 705 HIGH SCHOOL TEXTBOOKS	-1,831.71
455	07/26/2013	STARFALL EDUCATION	059 SP ED CURRICULCUM	-0.62
458	07/26/2013	DECKER EQUIPMENT	052 INSTRUCTIONAL SUPPLIES	33.28
461	07/26/2013	LIBERTY TIRE RECYCLING LLC	063 816 BAGS OF RUBBER	-5.42
466	07/26/2013	OFFICE DEPOT	000 050 SUPPLIES	6.04
482	07/31/2013	4IMPRINT	000 105 CLASSROOM SUPPLIES	-41.66
491	08/01/2013	ADOBE.COM	561 050 SOFTWARE	-198.00
496	08/02/2013	LAERDAL MEDICAL CORP	059 CPR/FIRST AID SUPPLIES	2.50
504	08/02/2013	DELL COMPUTER CORP	067 TONER CARTRIDGES	20.90
506	08/02/2013	CASEY BEASLEY	053 STRIPE HS PKG/CROSSWALKS	-25.00
507	08/02/2013	WALKER COMPANIES	000 067 NOTARY APPLICATIONS	-60.00
511	08/05/2013	QUILL	145 SCHOOL/OFFICE SUPPLIES	-17.42
515	08/05/2013	METRO MEDICAL SUPPLY, INC.	059 GLOVES FOR CLASSROOMS	-71.84
517	08/05/2013	P & K EQUIPMENT	055 CENTER WHEEL HUB	-39.99
Total Change Orders				-49,992.12

+ 1348.09

 - 48,644.03

General Fund 2013-2014
Detail Encumbrance Listing
As of 09/04/2013

PurOrder	Date	To Whom Issued / Detail Description	Po Description / Classification	
519	08/07/2013	WAREHOUSE SUPPLIES	145 PAPER FOR CLASSES	
		1 PALLET OF 8.5 X 11 PAPER COPY PAPER	000-1000-611-100-0001-000-145	1,940.00
			Total Purchase Order	1,940.00
520	08/07/2013	WAREHOUSE SUPPLIES	140- COPY PAPER	
		PALLET OF PAPER	029-1000-611-100-1050-000-140	970.00
			Total Purchase Order	970.00
522	08/07/2013	XPEDX	052 ADMIN PRINT SHOP	
		6 CASES CANARY #103341	000-2530-611-000-0000-000-052	277.86
			Total Purchase Order	277.86
523	08/07/2013	DELL COMPUTER CORP	059 INK FOR OFFICE PRINTER	
		DELL 2000 PAGE BALCK TONER CARTRIDGE FOR DELL 1250C COLOR PRINTERS	059-2340-611-239-0000-000-059	132.98
			Total Purchase Order	132.98
524	08/07/2013	JUDY W KELLOGG	051 MILEAGE REIMBURSEMENT	
		MILEAGE REIMBURSEMENT FOR CONFERENCE	000-2573-580-000-0000-000-051	26.56
			000-2573-580-000-0000-000-051	73.44
			Total Purchase Order	100.00
525	08/07/2013	DIAMOND TROPHIES	110 TEACHER NAME PLATES	
		TEACHER NAME PLATES CARE AND UPKEEP	000-2410-654-100-0000-000-110	378.00
			Total Purchase Order	378.00
526	08/07/2013	LEGACY SPORTS ACADEMY, INC	140 - SAFETY BAGS	
		SMALL HIT SPORTS PACK ITEM # 3071	000-2199-616-100-0000-000-140	90.00
			Total Purchase Order	90.00
527	08/07/2013	OTA	541 050 ENCYCLOMEDIA REGISTRAT	
		ENCYCLOMEDIA REGISTRATION FOR 1 ADMINISTRATOR OCT 1-2, 2013 COX CONVENTION CETNER, OKC, OK KRIS GREEN	541-2573-860-000-0000-000-050	95.00
			Total Purchase Order	95.00
528	08/07/2013	SCHOOL SPECIALTY	125 OFFICE SUPPLIES	
		DURABLE SHERPA DISPLAY DESKTOP REFERENCE SYSTEM-10 POCKET ASSORTED FRAMES	000-2410-619-000-0000-000-125	279.98
			Total Purchase Order	279.98
529	08/07/2013	WESTMORELAND THERAPIES SERVICES LLC	621 SPEECH LANGUAGE SERVICES	
		SPEECH SERVICES FOR THE 2013-2014 SCHOOL YEAR	621-2152-323-239-0000-000-059	3,375.00
			621-2152-323-239-0000-000-059	46,625.00
			Total Purchase Order	50,000.00
530	08/07/2013	LOWES CREDIT SERVICES	052 FLASHLIGHTS F/CR AND HRZ	
		052 PURCHASE FLASHLIGHTS FOR CANYON RIDGE AND HORIZON INTERMEDIATE SCHOOLS-2 PER PACKAGE	000-2620-618-000-0000-000-052	425.25
			000-2620-618-000-0000-000-052	22.50
			Total Purchase Order	447.75
531	08/07/2013	OFFICE DEPOT	510 TEACHER SUPPLIES	
		TAB DIVIDERS	000-1000-619-100-0000-000-510	22.00
			Total Purchase Order	99.00
532	08/07/2013	QUILL	135 STUDENT RECORD FOLDERS	
		QUILL BRAND 1/3-CUT LETTE-RSIZE FILE FOLDERS- RED-	000-2410-619-000-0000-000-135	55.15

General Fund 2013-2014
Detail Encumbrance Listing
As of 09/04/2013

PurOrder	Date	To Whom Issued / Detail Description	Po Description / Classification	
532	08/07/2013	QUILL	135 STUDENT RECORD FOLDERS	
		100 COUNT		
			Total Purchase Order	55.15
533	08/07/2013	UNITED RENTAL	069 USED SCISSOR LIFT FOR CR	
		PURCHASED 2006 SJYJACK 26' SCISSOR LIFT USE IN THE NORTH END OF THE DISTRICT. UNIT HAS 250 HOURS ON SERVICE CLOCK.	000-2650-769-000-0000-000-069	6,750.00
			Total Purchase Order	6,750.00
535	08/08/2013	PIONEER EQUIPMENT	053 PART F/SKID LOADER	
		053 PARTS TO REPAIR THE SKID LOADER	000-2620-618-000-0000-000-053	140.72
			000-2620-618-000-0000-000-053	109.28
			Total Purchase Order	250.00
536	08/09/2013	HONEYWELL INTERNATIONAL - ADI	055 BATTERIES F/FIRE ALARM @ME	
		055 PURCHASE BATTERIES FOR FIRE ALARM AT ME AND A FEW FOR STOCK	000-2620-618-000-0000-000-055	496.97
			Total Purchase Order	496.97
537	08/09/2013	EEI	055 HVAC CONTROL BOARDS F/LE	
		055 PURCHASE 2 HVAC CONTROLS FOR LE	000-2620-618-000-0000-000-055	1,364.00
			Total Purchase Order	1,364.00
538	08/09/2013	OFFICE WORLD, INC	510 CLASSROOM SUPPLIES	
		SPOTLIGHT PRESENTATION BOARD	000-1000-653-100-0000-000-510	63.69
		SPOTLIGHT CORRUGATED PRESENTATION HEADERS DISPLAY	000-1000-653-100-0000-000-510	58.98
		RAINBOW SUPER VALUE CONSTRUCTION PAPER REAM	000-1000-611-100-0000-000-510	30.38
		SPOTLIGHT PRESENTATION BOARD	000-1000-653-100-0000-000-510	63.69
			Total Purchase Order	216.74
539	08/09/2013	WAREHOUSE TECHNOLOGY	023-120 OFFICE SUPPLIES	
		Fax machine toner	023-2410-611-100-0000-000-120	149.98
			Total Purchase Order	149.98
540	08/09/2013	AMSAN EVE SUPPLY	057 CUSTODIAL SUPPLIES	
		50 CLOCKS #10126921	000-2620-619-000-0000-000-057	1,199.50
			Total Purchase Order	1,199.50
541	08/09/2013	ARCHWAY MARKETING SERVICES	HIGH SCHOOL TEXTBOOKS	
		HIGH SCHOOL AP WESTERN CIVILIZATION SINCE 1300, 2012 ISBN 9780495912590	198-1000-641-252-5546-000-705	17,157.75
		HIGH SCHOOL AP SOCIAL STUDIES - THE AMERICAN PAGEANT 2013 ISBN 9781111831066	198-1000-641-252-5546-000-705	25,125.00
		HIGH SCHOOL AP MYERS PSYCHOLOGY ISBN 1429244364	198-1000-641-252-5645-000-705	6,175.00
		1% HANDLING FEE - WE WILL PICK UP THE BOOKS	198-1000-641-252-5645-000-705	603.00
			Total Purchase Order	49,060.75
542	08/09/2013	THOMPSON SCHOOL BK.DEPOSITORY	HIGH SCHOOL TEXTBOOKS	
		HIGH SCHOOL AP AMERICAN GOVERNMENT ISBN 9780133274561	198-1000-641-252-5545-000-705	23,876.57
			Total Purchase Order	23,876.57
543	08/09/2013	DEE'S GRAPHIC SUPPLY	505 TEACHER SUPPLIES	
		23" POSTER PAPER BLACK ON WHITE	000-1000-611-000-0001-000-505	109.95
		23" POSTER PAPER BLUE ON WHITE	000-1000-611-000-0001-000-505	109.95
		23" POSTER PAPER RED ON WHITE	000-1000-611-000-0001-000-505	109.95
		23" POSTER PAPER BLACK ON PINK	000-1000-611-000-0001-000-505	109.95
		23" POSTER PAPER BLACK ON BLUE	000-1000-611-000-0001-000-505	109.95

General Fund 2013-2014
Detail Encumbrance Listing
As of 09/04/2013

PurOrder	Date	To Whom Issued / Detail Description	Po Description / Classification	
543	08/09/2013	DEE'S GRAPHIC SUPPLY	505 TEACHER SUPPLIES	
		23" POSTER PAPER BLACK ON YELLOW	000-1000-611-000-0001-000-505	109.95
		SHIPPING AND HANDLING	000-1000-611-000-0001-000-505	45.12
				Total Purchase Order
				704.82
544	08/09/2013	WESTCO COMPUTER & LAMINATOR	505 LAMINATING FILM	
		27" LAMINATING ROLLS PER SET OF TWO	000-1000-619-000-0001-000-505	120.00
				Total Purchase Order
				120.00
545	08/09/2013	HANCOCK FABRICS	412 MATERIALS, SUPPLIES, EQUIP	
		MATERIALS, SUPPLIES, EQUIPMENT FOR TEXTILES & APARREL CONSTRUCTION CLASSES	412-1000-681-314-8400-000-705	300.00
				Total Purchase Order
				300.00
546	08/09/2013	WAL-MART- 6032202040025802	412 FOOD, SUPPLIES, MATERIALS	
		FOOD, SUPPLIES, FOR FACS CLASSES	412-1000-681-314-8400-000-705	118.87
			412-1000-681-314-8400-000-705	281.13
		SUPPLIES, MATERIALS, EQUIPMENT FOR FACS CLASSES	412-1000-681-314-8400-000-705	7.00
				Total Purchase Order
				407.00
547	08/09/2013	HOMELAND	412 GROCERIES FOR FACS CLASSES	
		GROCERIES FOR FACS CLASSES	412-1000-681-314-3400-000-705	31.09
			412-1000-681-314-3400-000-705	968.91
				Total Purchase Order
				1,000.00
548	08/09/2013	WAL-MART- 6032202040025802	412 SUPPLIES FOR FACS CLASSES	
		SUPPLIES FOR FACS CLASSES	412-1000-681-314-3400-000-705	300.00
				Total Purchase Order
				300.00
549	08/09/2013	WAL-MART- 6032202040025802	412 GROCERIES FOR FACS CLASSES	
		GROCERIES FOR FACS CLASSES	412-1000-681-314-3400-000-705	1,000.00
				Total Purchase Order
				1,000.00
550	08/09/2013	MARDEL	023-120 OFFICE SUPPLIES	
		FILE FOLDERS	023-2410-619-100-1050-000-120	43.97
		6 PER PACKAGE	023-2410-619-100-1050-000-120	39.10
		NOTEPADS	023-2410-619-100-1050-000-120	7.37
			023-2410-619-100-1050-000-120	48.73
				Total Purchase Order
				139.17
551	08/09/2013	WESTCO COMPUTER & LAMINATOR	120 INSTRUCTIONAL SUPPLIES	
		LAMINATING FILM	000-2410-619-100-1050-000-120	360.00
				Total Purchase Order
				360.00
552	08/09/2013	PRO-ED DEPT. RB #0603	059 PYSCHS/LAKEHOMA	
		DAYC PROFILE/EXAMINER SUMMARY FORMS (25)	059-2140-614-239-0000-000-059	50.00
		DAYC COGNITIVE SUBTEST SCORING FORMS (25)	059-2140-614-239-0000-000-059	74.00
		DAYC ADAPTIVE BEHAVIOR SUBTEST SCORING FORMS (25)	059-2140-614-239-0000-000-059	74.00
		DAYC COMMUNICATION SUBTEST SCORING FORMS (25)	059-2140-614-239-0000-000-059	74.00
		DAYC PHYSICAL DEVELOPMENT SUBTEST SCORING FORMS (25)	059-2140-614-239-0000-000-059	74.00
		DAYC SOCIAL-EMOTIONAL SUBTEST SCORING FORMS (25)	059-2140-614-239-0000-000-059	74.00
		SHIPPING CHARGES	059-2140-614-239-0000-000-059	42.00
				Total Purchase Order
				462.00
553	08/09/2013	QUILL	145 TEACHER SUPPLIES	24
		QUILL STAINLESS STEEL 8" SCISSORS	000-1000-619-100-0001-000-145	51.45
		BLACK EXPO MARKERS PER DOZEN	000-1000-619-100-0001-000-145	378.95
		EXPO MARKERS RED	000-1000-619-100-0001-000-145	62.01

General Fund 2013-2014
Detail Encumbrance Listing
As of 09/04/2013

PurOrder	Date	To Whom Issued / Detail Description	Po Description / Classification	
553	08/09/2013	QUILL	145 TEACHER SUPPLIES	
		EXPO MARKERS GREEN		
		EXPO MARKERS BLUE	000-1000-619-100-0001-000-145	62.01
		INK PENS	000-1000-619-100-0001-000-145	47.36
		RED INK PENS	000-1000-619-100-0001-000-145	40.70
		PENCILS	000-1000-619-100-0001-000-145	78.65
		MANILLA FOLDERS	000-1000-619-100-0001-000-145	659.45
		POST IT STICKY NOTES 3X3 ASST. COLORS 4 PACK	000-1000-619-100-0001-000-145	257.32
		QUILL FULL STRIP STAPLER	000-1000-619-100-0001-000-145	89.85
		QUILL TAPE DISPENSER	000-1000-619-100-0001-000-145	57.45
		STAPLES QUILL BRAND	000-1000-619-100-0001-000-145	11.10
		PAPER CLIPS QUILL JUMBO SIZE	000-1000-619-100-0001-000-145	47.30
		DRY ERASE MARKER ERASERS	000-1000-619-100-0001-000-145	127.60
		RUBBER BANDS QUILL	000-1000-619-100-0001-000-145	5.59
		QUILL BRAND WIDE RULED	000-1000-619-100-0001-000-145	90.86
Total Purchase Order				2,129.66
554	08/09/2013	OFFICE DEPOT	023-120 OFFICE SUPPLIES	
		Envelopes 10x13 with clasp	023-2410-619-100-0000-000-120	8.41
		Blue My name is name...Name tags	023-2410-619-100-0000-000-120	35.40
		Cherry 8x11 Paper	023-2410-611-100-0000-000-120	16.70
		Yellow 8x11 paper	023-2410-611-100-0000-000-120	35.74
		Light Purple 8x11 paper	023-2410-611-100-0000-000-120	16.70
		Blue 8x11 paper	023-2410-611-100-0000-000-120	35.74
		Green 8x11 paper	023-2410-611-100-0000-000-120	35.74
		Office Depot scotch tape 3/4x1000	023-2410-619-100-0000-000-120	67.95
		office depot jumbo paper clips	023-2410-619-100-0000-000-120	9.48
		regular office depot paper clips	023-2410-619-100-0000-000-120	8.83
		LEGAL SIZE FILE FOLDERS 100/ BOX	023-2410-619-100-0000-000-120	16.71
		SMALL MULTICOLORED STICKY NOTES POST-IT 2 X 2 8 PADS PER PACKAGE	023-2410-619-100-0000-000-120	166.00
		DISPLAY BOARDS TRI-FOLD CORRUGATED 36 X 48	023-2410-619-100-0000-000-120	639.20
		LARGE COLORED NOTEPADS POST-IT 3 X 3 JEWEL POP COLORS 12 PER PACKAGE	023-2410-619-100-0000-000-120	83.10
Total Purchase Order				1,175.70
555	08/09/2013	HOLLIS PUBLIC SCHOOLS	PROF DEV ENGLISH WORKSHOP	
		30 ATTENDEES TO HOLLIS PUBIC SCHOOL WORKSHOP FOR ENGLISH CURRICULUM PROFESSIONAL DEVELOPMENT TRAINING ON 8/12/13 KELLY GONZALES, GAYLA CASE, JESTINE GAINES, MARSHA DUNFORD, LARJEN COLBERT, JACLYN GIAMMARIO, ERIN PATTON, ASHLEY STEWART, KAITLYN CAUDLE, CYNTHIA JARDINE, REBECCA NIETZEL, SUSAN LEWELLEN, MELANIE CICCORIA, LYNN HOFFMAN, VALERIE HAMMER, JUNE PAGE, MELANIE HYDEN-HIX, SANDRA WYNN, TAWNYA MERCHANT, CATHY FALKNER, JOY JEFFERS, LINDA SMITH, JONATHAN ATCHLEY, LINDA ATCHLEY, MATT VAUGHAN,	311-2212-582-270-0000-000-064	525.00
Total Purchase Order				525.00
556	08/13/2013	WAREHOUSE SUPPLIES	PAPER	
		DUPLICATING PAPER CASE	000-1000-611-100-1010-000-130	291.00
Total Purchase Order				291.00

General Fund 2013-2014
Detail Encumbrance Listing
As of 09/04/2013

PurOrder	Date	To Whom Issued / Detail Description	Po Description / Classification	
557	08/13/2013	QUILL	140 OFFICE SUPPLIES	
901-732907		HEAVY DUTY HOLE PUNCH	000-2410-619-100-0000-000-140	21.24
901-PT-90		BROTHERS LABEL MAKER	000-2410-619-100-0000-000-140	28.49
844-M231		LABEL MAKER TAPE	000-2410-619-100-0000-000-140	28.89
901-DMPC570DV		STICKY SQUARES 3X3 PASTEL 12PKT	000-2410-619-100-0000-000-140	23.19
901-683-4		FLAG NOTES	000-2410-619-100-0000-000-140	1.93
901-5845SSUC		POST IT PADS 5X8 LINED	000-2410-619-100-0000-000-140	11.58
901-7152F12AQ		STICKY SQUARES 1 1/2 X 2	000-2410-619-100-0000-000-140	10.80
901-3000BK		SHARPIES FINE POINT BLACK	000-2410-619-100-0000-000-140	8.49
901-3000RD		SHARPIES FINE POINT RED	000-2410-619-100-0000-000-140	8.49
215-25005		YELLOW HIGHLIGHTERS DZ	000-2410-619-100-0000-000-140	6.02
901-25009Q		PINK HIGHLIGHTERS DZ	000-2410-619-100-0000-000-140	6.02
901-25026		GREEN HIGHLIGHTERS DZ	000-2410-619-100-0000-000-140	6.02
901-830-56		DRY ERASE ORGANIZER	000-2410-619-100-0000-000-140	9.26
901-DMPC885		YELLOW PADS	000-2410-619-100-0000-000-140	7.72
901-13403Q		SCISSORS 3 PKG	000-2410-619-100-0000-000-140	26.07
901-711546QL		TAPE DISPENSER	000-2410-619-100-0000-000-140	25.90
901-620034X1000		TAPE REFILLS 6 PKT	000-2410-619-100-0000-000-140	10.68
901-79604Q		STAPLERS	000-2410-619-100-0000-000-140	40.53
901-791123		STAPLE REFILLS	000-2410-619-100-0000-000-140	1.80
901-793211		STAPLE REMOVER CLAW	000-2410-619-100-0000-000-140	3.45
901-JV53969		STAPLE REMOVER PENCIL GRIP	000-2410-619-100-0000-000-140	3.02
901-10702Q		RULERS	000-2410-619-100-0000-000-140	2.10
901-720500		BINDER CLIPS 5/8 IN DZ	000-2410-619-100-0000-000-140	6.93
901-721000		BINDER CLIPS 1 IN DZ	000-2410-619-100-0000-000-140	6.62
901-P1KS		PAPER CLIPS REGULAR 10 BOX	000-2410-619-100-0000-000-140	4.24
901-P1JG		PAPER CLIPS JUMBO SIZE 10 BOXES	000-2410-619-100-0000-000-140	7.72
901-790054		RUBBER BANDS ASST	000-2410-619-100-0000-000-140	5.40
901-WOTAPP10		WITE OUT TAPE 10 PKT	000-2410-619-100-0000-000-140	21.24
901-GSM11BK		BIC PENS BLACK	000-2410-619-100-0000-000-140	2.84
901-GSM11BE		BIC PENS BLUE	000-2410-619-100-0000-000-140	2.84
901-GSM11RD		BIC PENS RED	000-2410-619-100-0000-000-140	1.42
901-13882		PENCILS DIXON TICONDEROGAN #2 DZ	000-2410-619-100-0000-000-140	2.02
301-C7117A-BL		ALPHABETICAL EXPANDABLE FOLDER	000-2410-619-100-0000-000-140	17.77
907-7-BL-46		A-Z PAGE DIVIDERS	000-2410-619-100-0000-000-140	13.88
901-5160		MAILING ADDRESS LABELS AVERY 5160 3000CT	000-2410-619-100-0000-000-140	28.97
901-74925Q		MANILA FILE JACKETS LETTER SIZE 25CT	000-2410-619-100-0000-000-140	16.99
901-740137		MANILA FILE FOLDERS LETTER SIZE 100CT	000-2410-619-100-0000-000-140	10.02
901-7Q5215		HANGING FILE FOLDERS LETTER SIZE	000-2410-619-100-0000-000-140	27.04
901-WW10WES		WHITE LETTER ENVELOPES 500 CT	000-2410-619-100-0000-000-140	55.62
901-7CL6928		CLASP MANILA ENVELOPES 100 CT 6X9	000-2410-619-100-0000-000-140	10.73
9017CL91228		CLASP MANILA ENVELOPES 100CT 9X12	000-2410-619-100-0000-000-140	13.90
901-739501		2 INCH BLACK BINDER	000-2410-619-100-0000-000-140	14.80
901-739551		3 INCH BINDER BLACK	000-2410-619-100-0000-000-140	21.00
901-PC1500		BATTERIES AA SIZE DURACELL 2 DZ	000-2410-619-100-0000-000-140	16.99
904-78849		LYSOL WIPES	000-2410-618-100-0000-000-140	7.12
901-40090		PURELL 8OZ HAND SANITIZER	000-2410-616-100-0000-000-140	5.98
901-7-22381		ASTROBRIGHT GREEN PAPER	000-2410-611-100-0000-000-140	5.94
901-7-25861		ASTROBRIGHT ORANGE PAPER	000-2410-611-100-0000-000-140	5.94
901-7-22421		ASTROBRIGHT PINK PAPER	000-2410-611-100-0000-000-140	5.94
901-7-22431		ASTROBRIGHT YELLOW PAPER	000-2410-611-100-0000-000-140	5.94
901-7-22441		ASTROBRIGHT RED PAPER	000-2410-611-100-0000-000-140	5.94
901-7-22321		ASTROBRIGHT BLUE PAPER	000-2410-611-100-0000-000-140	5.94
901-22751		CARDSTOCK RED	000-2410-611-100-0000-000-140	12.59
901-82338		CARDSTOCK YELLOW	000-2410-611-100-0000-000-140	9.09

General Fund 2013-2014
Detail Encumbrance Listing
As of 09/04/2013

PurOrder	Date	To Whom Issued / Detail Description	Po Description / Classification	
557	08/13/2013	QUILL	140 OFFICE SUPPLIES	
901-82328		CARDSTOCK LIGHT BLUE	000-2410-611-100-0000-000-140	9.09
901-22781		CARDSTOCK TERRA GREEN	000-2410-611-100-0000-000-140	12.59
901-22871		CARDSTOCK PURPLE	000-2410-611-100-0000-000-140	12.59
Total Purchase Order				705.36
558	08/13/2013	QUILL	145 COMMUNICATION	
		ENVELOPES BUSINESS QUILL	000-1000-619-100-0001-000-145	39.95
		MANILLA ENVELOPES QUILL	000-1000-619-100-0001-000-145	14.39
		QUILL COLORED PAPER BLUE	000-1000-611-100-0001-000-145	8.48
		QUILL COLORED PAPER BRIGHT PINK	000-1000-611-100-0001-000-145	11.88
		QUILL COLORED PAPER CANARY YELLOW	000-1000-611-100-0001-000-145	8.48
		QUILL COLORED PAPER BRIGHT ORANGE	000-1000-611-100-0001-000-145	11.88
		QUILL COLORED PAPER RED	000-1000-611-100-0001-000-145	11.88
		QUILL COLORED PAPER LIGHT GREEN	000-1000-611-100-0001-000-145	8.48
		WAUSAU ASTRO BRITE COLORED PAPER PURPLE	000-1000-611-100-0001-000-145	23.78
		QUILL COLORED PAPER GOLDENROD	000-1000-611-100-0001-000-145	8.48
		QUILL COLORED PAPER GRAY	000-1000-611-100-0001-000-145	8.48
		ALPHABETIZER QUILL BRAND	000-1000-619-100-0001-000-145	13.09
Total Purchase Order				169.25
559	08/13/2013	K RENEE BOATMAN	705 TRAVEL REIMBURSEMENT	
		PRINCIPAL TRAVEL REIMBURSEMENT	023-2410-580-100-0000-000-705	1,000.00
Total Purchase Order				1,000.00
560	08/13/2013	CRAIG E CHESTNUT	705 TRAVEL REIMBURSEMENT	
		PRINCIPAL TRAVEL REIMBURSEMENT	023-2410-580-100-0000-000-705	1,000.00
Total Purchase Order				1,000.00
561	08/13/2013	RAMAE LYNN COLLINS	705 TRAVEL REIMBURSEMENT	
		PRINCIPAL TRAVEL REIMBURSEMENT	023-2410-580-100-0000-000-705	1,000.00
Total Purchase Order				1,000.00
562	08/13/2013	ROBERT D FOREMAN	705 TRAVEL REIMBURSEMENT	
		PRINCIPAL TRAVEL REIMBURSEMENT	023-2410-580-100-0000-000-705	1,000.00
Total Purchase Order				1,000.00
563	08/13/2013	BELINDA L HARPER	705 TRAVEL REIMBURSEMENT	
		PRINCIPAL TRAVEL REIMBURSEMENT	023-2410-580-100-0000-000-705	1,000.00
Total Purchase Order				1,000.00
564	08/13/2013	KENNY NELSON	705 TRAVEL REIMBURSEMENT	
		PRINCIPAL TRAVEL REIMBURSEMENT	023-2410-580-100-0000-000-705	1,000.00
Total Purchase Order				1,000.00
565	08/13/2013	TERESA LYNN WILKERSON	705 TRAVEL REIMBURSEMENT	
		PRINCIPAL TRAVEL REIMBURSEMENT	023-2410-580-100-0000-000-705	1,000.00
Total Purchase Order				1,000.00
566	08/13/2013	RENAISSANCE LEARNING	056 TECHNOLOGY	
		SERVICES - MANAGEMENT	000-2230-530-000-0000-000-056	1,800.00
		LAKEHOMA	000-2230-530-000-0000-000-056	13,712.83
		ACCELERATED MATH		
		ACCELERATED READER		
		MATHFACTS IN A FLASH		
		STAR EARLY LITERACY		
		STAR MATH		
		STAR READER		
		CENTENNIAL	000-2230-530-000-0000-000-056	13,712.83

General Fund 2013-2014
Detail Encumbrance Listing
As of 09/04/2013

PurOrder	Date	To Whom Issued / Detail Description	Po Description / Classification	
566	08/13/2013	RENAISSANCE LEARNING	056 TECHNOLOGY	
		ACCELERATED MATH ACCELERATED READER MATHFACTS IN A FLASH STAR EARLY LITERACY STAR MATH STAR READER		
		CREEK	000-2230-530-000-0000-000-056	13,712.83
		ACCELERATED MATH ACCELERATED READER MATHFACTS IN A FLASH STAR EARLY LITERACY STAR MATH STAR READER		
		ELEMENTARY	000-2230-530-000-0000-000-056	13,712.83
		ACCELERATED MATH ACCELERATED READER MATHFACTS IN A FLASH STAR EARLY LITERACY STAR MATH STAR READER		
		TRAILS	000-2230-530-000-0000-000-056	13,712.83
		ACCELERATED MATH ACCELERATED READER MATHFACTS IN A FLASH STAR EARLY LITERACY STAR MATH STAR READER		
		VALLEY	000-2230-530-000-0000-000-056	13,791.04
		ACCELERATED MATH ACCELERATED READER MATHFACTS IN A FLASH STAR EARLY LITERACY STAR MATH STAR READER		
			Total Purchase Order	84,155.19
567	08/13/2013	APPLE INC.	060 IPAD FOR CUST TRAINER	
		PURCHASE IPAD FOR NEW CUSTODIAL TRAINER POSITION.	000-2620-653-000-0000-000-060	499.99
			Total Purchase Order	499.99
568	08/13/2013	APPLE INC.	198 IPADS ADV COMM	
		BH422LL/A 10 PK IPADS ADVANCE COMM FOR INTERMEDIATE CENTERS	198-1000-653-251-0000-000-140 198-1000-653-251-0000-000-145	2,395.00 2,395.00
			Total Purchase Order	4,790.00
569	08/13/2013	CDW GOVERNMENT, INC.	060 IPAD COVER	
		IPAD COVER FOR CUSTODIAL TRAINER POSITION	000-2620-653-000-0000-000-060	39.99
			Total Purchase Order	39.99
570	08/13/2013	CDW GOVERNMENT, INC.	198 GRIFFIN CASES ADV COMM	
		GRIFFIN SURVIVOR CASES BLACK FOR ADV COMM FOR INTER CENTERS	198-1000-653-251-0000-000-140 198-1000-653-251-0000-000-145	199.95 199.95
			Total Purchase Order	399.90
571	08/13/2013	DELL COMPUTER CORP	064 PRINTER FOR LINDA ATCHLEY	
		DELL PRINTER FOR LINDA ATCHLEY DELL C1760nw #C176AY2	000-2212-653-000-0000-000-064	224.99
				28
			Total Purchase Order	224.99
572	08/13/2013	BARNES & NOBLE	110 INSTRUCTION	

General Fund 2013-2014
Detail Encumbrance Listing
As of 09/04/2013

PurOrder	Date	To Whom Issued / Detail Description	Po Description / Classification	
572	08/13/2013	BARNES & NOBLE	110 INSTRUCTION	
		COMMON CORE MATHEMATICS GRADE 4	000-1000-681-900-1050-000-110	20.11
		COMMON CORE GRADE 3	000-1000-681-900-1050-000-110	20.11
		COMMON CORE GRADE 2	000-1000-681-900-1050-000-110	18.47
		COMMON CORE MATHEMATICS GRADE 1	000-1000-681-900-1050-000-110	19.47
		COMMON CORE CURRICULUM MAPS ELA	000-1000-681-900-1050-000-110	113.80
			Total Purchase Order	191.96
573	08/13/2013	ANGELA M CHOATE	050 GATE TEACHER MILEAGE	
		ESTIMATED TRAVEL FOR GATE TEACHER MILEAGE FOR 13-14 SCHOOL YEAR	050-1000-580-251-0000-000-050	350.00
			Total Purchase Order	350.00
574	08/13/2013	HAL LEONARD CORP.	050 MUSIC EXPRESS	
		2013-2014 1 PREMIUM SUBSCRIPTION PACKAGE CENTENNIAL ATTN WHITNEY WALDROP	050-1000-648-100-3000-000-135	265.00
		2013-2014 1 PREMIUM SUBSCRIPTION PACKAGE CREEK ATTN MEGAN GODFRY	050-1000-648-100-3000-000-125	265.00
		2013-2014 1 PREMIUM SUBSCRIPTION PACKAGE LAKEHOMA ATTN TERRE MCDONALD	050-1000-648-100-3000-000-115	265.00
		2013-2014 1 PREMIUM SUBSCRIPTION PACKAGE MUSTANG ELEM ATTN RITA MEYERS	050-1000-648-100-3000-000-105	265.00
		2013-2014 1 PREMIUM SUBSCRIPTION PACKAGE TRAILS ATTN DIANE JOHNSON	050-1000-648-100-3000-000-120	265.00
		2013-2014 1 PREMIUM SUBSCRIPTION PACKAGE VALLEY ATTN MAUREEN FULLER	050-1000-648-100-3000-000-110	265.00
		2013-2014 1 PREMIUM SUBSCRIPTION PACKAGE CANYON RIDGE ATTN SOHAILAH STOUT	050-1000-648-100-3000-000-145	265.00
		2013-2014 1 PREMIUM SUBSCRIPTION PACKAGE HORIZON ATTN ERIN RAIBER	050-1000-648-100-3000-000-140	265.00
			Total Purchase Order	2,120.00
575	08/13/2013	CYNDE LARUE MORRIS	050 GATE TEACHER MILEAGE	
		ESTIMATED TRAVEL FOR GATE TEACHER MILEAGE FOR 13-14 SCHOOL YEAR	050-1000-580-251-0000-000-050	350.00
			Total Purchase Order	350.00
576	08/13/2013	PLANK ROAD PUBLISHING, INC	050 MUSIC SUBSCRIPTION	
		MK8-SD24 MUSIC K-8 CENTENNIAL ATTN WHITNEY WALDROP	050-1000-648-100-3000-000-135	104.75
		MK8-SD24 MUSIC K-8 CREEK ATTN MEGAN GODFRY	050-1000-648-100-3000-000-125	104.75
		MK8-SD24 MUSIC K-8 LAKEHOMA ATTN TERRE MCDONALD	050-1000-648-100-3000-000-115	104.75
		MK8-SD24 MUSIC K-8 MUSTANG ELEM ATTN RITA MEYERS	050-1000-648-100-3000-000-105	104.75
		MK8-SD24 MUSIC K-8 TRAILS ATTN DIANE JOHNSON	050-1000-648-100-3000-000-120	104.75
		MK8-SD24 MUSIC K-8 VALLEY ATTN MAUREEN FULLER	050-1000-648-100-3000-000-110	104.75
		MK8-SD24 MUSIC K-8 CANYON RIDGE ATTN SOHAILAH STOUT	050-1000-648-100-3000-000-145	104.75
		MK8-SD24 MUSIC K-8 HORIZON ATTN ERIN RAIBER	050-1000-648-100-3000-000-140	104.75
			Total Purchase Order	838.00
577	08/13/2013	CRYSTAL RUMBAUGH	050 GATE TEACHER MILEAGE	
		ESTIMATED TRAVEL FOR GATE TEACHER MILEAGE FOR 13-14 SCHOOL YEAR	050-1000-580-251-0000-000-050	350.00
			Total Purchase Order	350.00
578	08/13/2013	KRISTI STEPHENS	050 GATE TEACHER MILEAGE	29
		ESTIMATED TRAVEL FOR GATE TEACHER MILEAGE FOR 13-14 SCHOOL YEAR	050-1000-580-251-0000-000-050	350.00
			Total Purchase Order	350.00

General Fund 2013-2014
Detail Encumbrance Listing
As of 09/04/2013

PurOrder	Date	To Whom Issued / Detail Description	Po Description / Classification	
579	08/13/2013	LOWES CREDIT SERVICES	510 CLASSROOM SUPPLIES	
		HOOKLESS FROST SNAP LINER	000-1000-619-100-0000-000-510	88.07
				Total Purchase Order
				88.07
580	08/13/2013	WAL-MART- 6032202040025802	412 510 TECH ED SUPPLIES	
		PLASTIC TUBS	412-1000-681-317-8800-100-510	25.00
		PENS, MARKERS, PENCILS, SCISSORS, GLUE	412-1000-619-317-8800-100-510	99.34
		FOAM BOARD, SEA FOAM	412-1000-681-317-8800-100-510	25.00
				Total Purchase Order
				149.34
581	08/13/2013	SLRS, INC.	050 TRANSLATION SERVICES	
		TRANSLATION SERVICES FOR ENTIRE DISTRICT 2013-2014	050-2199-323-000-0000-000-050	373.78
		SCHOOL YEAR	050-2199-323-000-0000-000-050	626.22
				Total Purchase Order
				1,000.00
582	08/13/2013	THOMPSON SCHOOL BK.DEPOSITORY	HIGH SCHOOL - AP BOOKS	
		HIGH SCHOOL AP GOVERNMENT IN AMERICA 2014	198-1000-641-252-5545-000-705	9,877.60
		ADOPTION ISBN 0205865755		
				Total Purchase Order
				9,877.60
583	08/13/2013	THOMPSON SCHOOL BK.DEPOSITORY	CREEK ELEM - TEXTBOOKS	
		CREEK ELEM - SS WEEKLY	050-1000-644-100-5400-000-125	4,695.24
		K- OKLA KINDERGARTEN STUDIES WEEKLY 6 YR 15503054A		
		1ST GRADE - OKLA FIRST GRADE SW 6 YR 15503062A	050-1000-644-100-5400-000-125	4,695.24
		2ND GRADE - OKLA SECOND GRADE SW 6 YR 15503070A	050-1000-644-100-5400-000-125	5,869.05
		3RD GRADE - OKLA STUDIES WEEKLY - OUR STATE 6 YR 23257255A	050-1000-644-100-5400-000-125	4,602.40
		4TH GRADE - OKLA STUDIES WEEKLY - US REGION 6 YR 23257270A	050-1000-644-100-5400-000-125	5,690.24
				Total Purchase Order
				25,552.17
584	08/13/2013	THOMPSON SCHOOL BK.DEPOSITORY	LAKEHOMA ELEM - TEXTBOOKS	
		LAKEHOMA ELEM - SS WEEKLY	050-1000-644-100-5400-000-115	5,335.50
		K - OKLA KINDERGARTEN STUDIES WEEKLY 6 YR 15503054A		
		1ST GRADE - OKLA FIRST GRADE SW 6 YR 15503062A	050-1000-644-100-5400-000-115	6,438.17
		2ND GRADE - OKLA 2ND GRADE SW 6 YR 15503070A	050-1000-644-100-5400-000-115	6,509.31
		3RD GRADE - OKLA STUDIES WEEKLY - OUR STATE 6 YR 23257255A	050-1000-644-100-5400-000-115	6,652.56
		4TH GRADE - OKLA STUDIES WEEKLY - US REGIONS 6 YR 23257270A	050-1000-644-100-5400-000-115	7,112.80
				Total Purchase Order
				32,048.34
585	08/13/2013	THOMPSON SCHOOL BK.DEPOSITORY	CENTENNIAL ELEM - TEXTBOOKS	
		CENTENNIAL ELEM - SS WEEKLY	050-1000-644-100-5400-000-135	3,201.30
		K- OKLA K STUDIES WEEKLY 6 YR 15503054A		
		1ST GRADE - OKLA FIRST GRADE SW 6 YR 15503062A	050-1000-644-100-5400-000-135	3,734.85
		2ND GRADE - OKLA 2 GRADE SW 6 YR 15503070A	050-1000-644-100-5400-000-135	3,663.71
		3RD GRADE - OKLA STUDIES WEEKLY - OUR STATE 6 YR 23257255A	050-1000-644-100-5400-000-135	3,891.12
		4TH GRADE - OKLA STUDIES WEEKLY - US REGIONS 6 YR 23257270A	050-1000-644-100-5400-000-135	4,184.00
				Total Purchase Order
				18,674.98
586	08/13/2013	THOMPSON SCHOOL BK.DEPOSITORY	VALLEY ELEM - TEXTBOOKS	
		VALLEY ELEM - SS WEEKLY	050-1000-644-100-5400-000-110	5,513.35
		K - OKLA K STUDIES WEEKLY 6 YR 15503054A		30
		1ST GRADE - OKLA FIRST GRADE SW 6 YR 15503062A	050-1000-644-100-5400-000-110	5,975.76
		2ND GRADE - OK SECOND GRADE SW 6 YR 15503070A	050-1000-644-100-5400-000-110	6,118.04
		3RD GRADE - OK STUDIES WEEKLY - OUR STATE 6 YR	050-1000-644-100-5400-000-110	5,857.60

General Fund 2013-2014
Detail Encumbrance Listing
As of 09/04/2013

PurOrder	Date	To Whom Issued / Detail Description	Po Description / Classification	
586	08/13/2013	THOMPSON SCHOOL BK.DEPOSITORY	VALLEY ELEM - TEXTBOOKS	
		257255A		
		4TH GRADE - OKLA. STUDIES WEEKLY - US REGIONS 6 YR	050-1000-644-100-5400-000-110	7,029.12
		23257270A		
Total Purchase Order				30,493.87
587	08/13/2013	THOMPSON SCHOOL BK.DEPOSITORY	MUSTANG ELEM - TEXTBOOKS	
		MUSTANG ELEM. - SS WEEKLY	050-1000-644-100-5400-000-105	3,557.00
		K- OKLA K STUDIES WEEKLY 6 YEAR 15503054A		
		1ST - OKLA FIRST GRADE SW 6 YEAR 15503062A	050-1000-644-100-5400-000-105	3,841.56
		2ND GRADE - OKLA SECOND GRADE SW 6YR 15503070A	050-1000-644-100-5400-000-105	4,161.69
		3RD GRADE - OKLA STUDIES WEEKLY - OUR STATE 6 YR	050-1000-644-100-5400-000-105	5,188.16
		23257255A		
		4TH GRADE - OKLA STUDIES WEEKLY - US REGIONS 6 YR	050-1000-644-100-5400-000-105	5,188.16
		23257270A		
Total Purchase Order				21,936.57
588	08/13/2013	THOMPSON SCHOOL BK.DEPOSITORY	TRAILS ELEM - TEXTBOOKS	
		TRAILS ELEM - TEXTBOOKS - SS WEEKLY	050-1000-644-100-5400-000-120	5,335.50
		K - OKLA K STUDIES WEEKLY 6 YEAR - 15503054A		
		1ST - OKLA FIRST GRADE SW 6YR - 15503054A	050-1000-644-100-5400-000-120	6,438.17
		2ND GRADE - OKLA 2ND GRADE SW 6 YEAR 15503070A	050-1000-644-100-5400-000-120	6,509.31
		3RD - OKLA STUDIES WEEKLY - OUR STATE 6 YEAR	050-1000-644-100-5400-000-120	6,652.56
		23257255A		
		4TH - OKLA STUDIES WEEKLY - US REGIONS 6 YEAR	050-1000-644-100-5400-000-120	7,112.80
		23257270A		
Total Purchase Order				32,048.34
589	08/13/2013	THOMPSON SCHOOL BK.DEPOSITORY	CANYON RIDGE - TEXTBOOKS	
		CANYON RIDGE - TEXTBOOKS - SS WEEKLY	050-1000-644-100-5400-000-145	18,828.00
		5TH GRADE - OKLAHOMA STUDIES WEEKLY - US REGIONS 6 YR 23257261A		
Total Purchase Order				18,828.00
590	08/13/2013	THOMPSON SCHOOL BK.DEPOSITORY	050 140 HORIZON - TEXTBOOKS	
		HORIZON TEXTBOOKS - SS WEEKLY	050-1000-644-100-5400-000-140	14,644.00
		5TH GRADE - OKLAHOMA STUDIES WEEKLY - US REGIONS 6YR		
Total Purchase Order				14,644.00
591	08/13/2013	UMB BANK N.A.	2013-2014 ADMINISTRATIVE FEE	
		2013-2014 ADMINISTRATIVE FEE AND ACCEPTANCE FEES	000-2511-810-000-0000-000-051	300.00
			000-2511-810-000-0000-000-051	1,550.00
Total Purchase Order				1,850.00
592	08/13/2013	WAREHOUSE SUPPLIES	510 PAPER	
		PALET OF PAPER	029-1000-611-100-0000-000-510	970.00
Total Purchase Order				970.00
593	08/13/2013	WAREHOUSE SUPPLIES	140 OFFICE SUPPLIES	
		1503 RECEIPT BOOKS	029-2410-619-100-0000-000-140	79.00
Total Purchase Order				79.00
594	08/13/2013	OKLAHOMA AUTO DOOR	053 BLEACHER REPAIRS	
		053 BLEACHER REPAIRS AND SUPPLIES TO REPAIR BLEACHERS	000-2620-438-000-0000-000-053	1,500.00
Total Purchase Order				1,500.00
595	08/13/2013	OKLAHOMA SAFETY COUNCIL	060 MEMBERSHIP DUES	
		060 MEMBERSHIP DUES	000-2620-810-000-0000-000-060	350.00

General Fund 2013-2014
Detail Encumbrance Listing
As of 09/04/2013

PurOrder	Date	To Whom Issued / Detail Description	Po Description / Classification	
595	08/13/2013	OKLAHOMA SAFETY COUNCIL	060 MEMBERSHIP DUES	
			Total Purchase Order	350.00
596	08/13/2013	WAL-MART- 6032202040025802	053 SUPPLIES AND MATERIALS	
		PURCHASE SUPPLIES AND MATERIALS -	000-2620-618-000-0000-000-053	125.81
		CLEANING MATERIALS/SMALL PARTS	000-2620-618-000-0000-000-053	874.19
			Total Purchase Order	1,000.00
597	08/13/2013	OFFICE DEPOT	140 - SPEC ED CLASSROOM	
		SMEAD MANILA REINFORCED TAB FASTENER FOLDERS LETTER SIZE ITEM# 207126	000-1000-619-100-1050-000-140	61.98
		SWINGLINER SMART TOUCH 2-HOLE PUNCH ITEM# 203542	000-1000-619-100-1050-000-140	9.99
			Total Purchase Order	71.97
598	08/13/2013	OFFICE DEPOT	510 CLASSROOM SUPPLIES	
		DYMO D1 45013 BLACK ON WHITE TAPE .5X23	000-1000-619-100-0000-000-510	35.98
		HP Q3960A BLACK INK	000-1000-611-100-0000-000-510	187.98
		Q3964A IMAGING DRUM FOR hp 2840	000-1000-611-100-0000-000-510	228.38
		YELLOW INK Q3962A HP	000-1000-611-100-0000-000-510	112.99
		CYAN INK FOR HP 2840 Q3961A	000-1000-611-100-0000-000-510	112.99
		MAGENTA TONER FOR HP 2840 Q3963A	000-1000-611-100-0000-000-510	112.99
			Total Purchase Order	791.31
599	08/13/2013	OFFICE DEPOT	064 CURR DEPT SUPPLIES	
		BLACK PENS ITEM#181594 - T. SKINNER	000-2212-619-100-0000-000-064	13.60
		5X8 NOTE PADS - ITEM 247354	000-2212-619-100-0000-000-064	22.50
		5X8 NOTE PADS ITEM 247345	000-2212-619-100-0000-000-064	22.50
		TAPE DISPENSER WITH 6 ROLLS OF TAPE - S. EDWARDS ITEM#567213	000-2212-619-100-0000-000-064	17.09
		3X5 INDEX CARDS - T. SKINNER - ITEM 279688	000-2212-619-100-0000-000-064	8.30
		BIG HIGHLIGHTERS ASST. SHARPIE LARGE PKG 12 ITEM#708586	000-2212-619-100-0000-000-064	21.36
		BIG PERMANENT MARKERS ASST. PKG OF 4 ITEM #134200	000-2212-619-100-0000-000-064	19.88
		LOGITECH M310 WIRELESS OPTICAL MOUSE SILVER ITEM#262107	000-2212-619-100-0000-000-064	29.98
		SMEAD COLOR FILE LETTER SIZE ITEM #113253	000-2212-619-100-0000-000-064	174.36
		SMEAD COLOR HANGING FOLDERS LETTER SIZE ITEM#959429	000-2212-619-100-0000-000-064	141.24
		STACKING CRATE FOR FILES ITEM # 430723	000-2212-619-100-0000-000-064	107.88
		STAMP APPROVED BLUE ITEM# 266469	000-2212-619-100-0000-000-064	17.97
		LABEL MAKER TAPE TZ231 ITEM # 479596	000-2212-619-100-0000-000-064	34.99
		Item # 429175 Jumbo Silver Box of 100 clips - D. Locke	000-2212-619-100-0000-000-064	1.41
		Item # 959429 Color Hanging Folders letter size - D. Locke	000-2212-619-100-0000-000-064	11.77
		ITEM # 128853 - CHISEL TIP HIGHLIGHTERS - D. LOCKE	000-2212-619-100-0000-000-064	5.98
		ITEM # 234192 - PENS - D. LOCKE	000-2212-619-100-0000-000-064	10.44
		ITEM # 305466 - WRITING PADS - D. LOCKE	000-2212-619-100-0000-000-064	7.13
		ITEM # 558410 CD/DVD SLEEVES - G. LOVING	000-2212-619-100-0000-000-064	8.99
		ITEM # 869296 - CD REWRITABLE MEDIA CD - G. LOVING	000-2212-619-100-0000-000-064	71.90
		ITEM # 308114 - JUMBO SILVER PAPER CLIPS - G. LOVING	000-2212-619-100-0000-000-064	9.02
		ITEM # 810945 HANGING FOLDER 1/3 CUT LEGAL SIZE - G. LOVING	000-2212-619-100-0000-000-064	321.26
		ITEM # 578785 FILE FOLDERS LETTER SIZE 1/3 CUT - G. LOVING	000-2212-619-100-0000-000-064	21.70

General Fund 2013-2014
Detail Encumbrance Listing
As of 09/04/2013

PurOrder	Date	To Whom Issued / Detail Description	Po Description / Classification	
599	08/13/2013	OFFICE DEPOT	064 CURR DEPT SUPPLIES	
			Total Purchase Order	801.25
600	08/13/2013	OFFICE DEPOT	059 SP SER OFFICE SUPPLIES	
		SMEAD REINFORCED TAB KRAFT FILE FOLDERS, LETTER SIZE, 1/3 CUT, PACK OF 100	059-2199-619-239-0000-000-059	105.24
		SMEAD MANILA FILE FOLDERS, LETTER SIZE, 1/3 CUT, PACK OF 100	059-2199-619-239-0000-000-059	18.98
		REDI TAG REMOVABLE INDEX TABS, ASSORTED COLORS, 2 X 11/16	059-2199-619-239-0000-000-059	4.48
		AVERY PRINTABLE SELF-ADHESIVE TABS, WHITE, PACK OF 80	059-2199-619-239-0000-000-059	17.08
		STANLEY BOSTITCH PREMIUM STANDARD CHISEL-POINT STAPLES, PLASTIC BOX, BOX OF 5000	059-2199-619-239-0000-000-059	39.39
		OFFICE DEPOT BRAND SCHOOL GRADE 2-POCKET PAPER PORTFOLIOS, 8 1/2 X 11, ASSORTED COLORS, PACK OF 10	059-2199-619-239-0000-000-059	8.58
		SHARPIE RETRACTABLE HIGHLIGHTERS, NEON PINK, PK OF 12	059-2199-619-239-0000-000-059	15.29
		DYMO LABELWRITER 30251 WHITE ADDRESS LABELS, 3.5 X 1.13, PACK OF 2 ROLLS (260 LABELS)	059-2199-619-239-0000-000-059	46.08
			Total Purchase Order	255.12
601	08/13/2013	DEMCO INC.	050-BAND/MUSIC SUPPLIES	
		Luxor Adjustable-Height AV cart w/o tray Item # WE15300770	050-1000-654-100-1050-000-140	169.99
			Total Purchase Order	169.99
602	08/13/2013	DEMCO INC.	050- MEDIA SUPPLIES	
		Demco Library Quite 6 sloping shelf, single sided booktruck Item#WM12228850 Color: Bahama Blue	050-1000-654-100-1050-000-140	287.99
		Sandusky Lee Baic Sloping-shelf Booktruck Item#WM13587350 Color: Electric Green	050-1000-654-100-1050-000-140	151.99
		Demco Library Quite 3 sloping shelf, single sided booktruck Item#WM12229250 Color: Wisteria	050-1000-654-100-1050-000-140	288.99
			Total Purchase Order	728.97
603	08/13/2013	NASCO	050 - ART SUPPLIES	
		ART SUPPLIES	050-1000-619-100-1050-000-140	819.76
			050-1000-619-100-1050-000-140	180.24
			Total Purchase Order	1,000.00
604	08/13/2013	QUILL	050- CLASS/WORKROOM SUPPLIES	
		1 - 15" Swingline Ingento CL510 Classic Maple Paper Trimmer	050-1000-619-100-1050-000-140	111.99
		1 - 12" Swingline Ingento CL500 Classic Maple Paper Trimmer	050-1000-619-100-1050-000-140	88.61
		1 - 15" X-acto Heavy Duty Paper Trimmer	050-1000-619-100-1050-000-140	59.19
		EXPO MARKERS - ASSORTE COLORS 12/BOX	050-1000-619-100-1050-000-140	470.00
		DRY ERASER	050-1000-619-100-1050-000-140	54.52
		BLACK PENS 12/BOX	050-1000-619-100-1050-000-140	34.78
		RED PENS 12/BOX	050-1000-619-100-1050-000-140	34.78
		ITEM # 901-GSM11RD		
		#2 PENCILS 12/BOX	050-1000-619-100-1050-000-140	67.21
		ITEM # 901-13806Q		33
		LETTER SIZE MANILA FILE FOLDERS 100/BOX	050-1000-619-100-1050-000-140	563.53
		ITEM# 901-7-41137		
		3X3 YELLOW STICKY NOTES QUILL BRAND	050-1000-619-100-1050-000-140	352.03

General Fund 2013-2014
Detail Encumbrance Listing
As of 09/04/2013

PurOrder	Date	To Whom Issued / Detail Description	Po Description / Classification	
604	08/13/2013	QUILL	050- CLASS/WORKROOM SUPPLIES	
		ITEM# 901-7384YW		
		1 1/2 QUILL BRAND STICKY NOTES	050-1000-619-100-1050-000-140	225.13
		ITME# 901-7152F12AQ		
		SHARPIE MARKERS - BLACK	050-1000-619-100-1050-000-140	33.96
		12/BOX		
		ITEM# 901-3000BK		
		SHARPIE MARKERS - RED	050-1000-619-100-1050-000-140	33.96
		ITEM#		
		STAPLES	050-1000-619-100-1050-000-140	17.39
		ITEM # 901-791123		
Total Purchase Order				2,147.08
605	08/13/2013	JONATHAN CURTIS ATCHLEY	13-14 MILEAGE REIMBURSEMENT	
		13-14 MILEAGE REIMBURSEMENT FOR JONATHAN ATCHLEY	000-2212-580-000-0000-000-064	500.00
Total Purchase Order				500.00
606	08/13/2013	LINDA GAYLE ATCHLEY	13-14 MILEAGE REIMBURSEMENT	
		13-14 MILEAGE REIMBURSEMENT FOR LINDA ATCHLEY	000-2212-580-000-0000-000-064	500.00
Total Purchase Order				500.00
607	08/13/2013	STACY LYNETTE EDWARDS	13-14 MILEAGE REIMBURSEMENT	
		13-14 MILEAGE REIMBURSEMENT FOR STACY EDWARDS	000-2212-580-000-0000-000-064	500.00
Total Purchase Order				500.00
608	08/13/2013	TAMARA GORE	13-14 MILEAGE REIMBURSEMENT	
		13-14 MILEAGE REIMBURSEMENT FOR TAMARA GORE	000-2212-580-000-0000-000-064	500.00
Total Purchase Order				500.00
610	08/13/2013	GEOFFREY R KINGSLEY	13-14 MILEAGE REIMBURSEMENT	
		13-14 MILEAGE REIMBURSEMENT FOR GEOFF KINGSLEY	000-2212-580-000-0000-000-064	500.00
Total Purchase Order				500.00
611	08/13/2013	CATHERINE MARIE LINDSEY	13-14 MILEAGE REIMBURSEMENT	
		13-14 MILEAGE REIMBURSEMENT FOR CATHY LINDSEY	000-2212-580-000-0000-000-064	500.00
Total Purchase Order				500.00
612	08/13/2013	CAROLYN DENISE LOCKE	13-14 MILEAGE REIMBURSEMENT	
		13-14 MILEAGE REIMBURSEMENT FOR DENISE LOCKE	000-2212-580-000-0000-000-064	500.00
Total Purchase Order				500.00
613	08/13/2013	GAILE ANN LOVING	13-14 MILEAGE REIMBURSEMENT	
		13-14 MILEAGE REIMBURSEMENT FOR GAIL LOVING	000-2212-580-000-0000-000-064	500.00
Total Purchase Order				500.00
614	08/13/2013	TRACY PAIGE SKINNER	13-14 MILEAGE REIMBURSEMENT	
		13-14 MILEAGE REIMBURSEMENT FOR TRACY SKINNER	000-2212-580-000-0000-000-064	500.00
Total Purchase Order				500.00
615	08/14/2013	PROMOTIONAL & BUSINESS SERVICES	051 ACTIVITY FUND CHECKS	
		ACTIVITY FUND CHECKS (2500@ .168=343.15)	000-2511-611-000-0000-000-051	413.15
		ESTIMATED \$70.00 SHIPPING		
Total Purchase Order				413.15
616	08/14/2013	WAL-MART- 6032202040025802	057 MISC SUPPLIES/MATERIALS	
		057 PURCHASE MISC SUPPLIES/MATERIALS TO BE USED	000-2620-618-000-0000-000-057	97.36
		FOR THE CUSTODIAL DEPARTMENT	000-2620-618-000-0000-000-057	34
Total Purchase Order				500.00
617	08/14/2013	WESTCO COMPUTER & LAMINATOR	023 135 LAMINATION	

General Fund 2013-2014
Detail Encumbrance Listing
As of 09/04/2013

PurOrder	Date	To Whom Issued / Detail Description	Po Description / Classification	
617	08/14/2013	WESTCO COMPUTER & LAMINATOR	023 135 LAMINATION	
		LAMINATION FILM FOR LAMINATION MACHINE	023-2410-619-000-0000-000-135	120.00
				Total Purchase Order
618	08/14/2013	TEACHWARE EDUCATIONAL	561 050 SOFTWARE PURCHASE	
		ADOBE X PRO	561-1000-653-424-0000-000-050	198.00
				Total Purchase Order
619	08/16/2013	DELL COMPUTER CORP	059 IEP FACILITATOR LAPTOP	
		LAPTOP E5530 ----- EQUOTE #1014913270658	059-2490-653-239-0000-000-059	1,032.35
		PRINTER, DELL C1760NW	059-2490-653-239-0000-000-059	224.99
				Total Purchase Order
620	08/16/2013	BATTERIES PLUS, LLC.	056 TECHNOLOGY	
		WP3-12 BATTERIES	000-2580-613-000-0000-000-056	526.80
		12V 3.3AH Werker AGM Battery .250" Faston Terminal WKA12-3.3F2		
				Total Purchase Order
621	08/16/2013	WENGER CORP.	063 TRANSPORT CART	
		WENGER TRANSPORT CART WITH WRAP	063-2199-654-827-0000-000-705	1,445.00
		FRIEGHT	063-2199-654-827-0000-307-705	163.00
				Total Purchase Order
622	08/16/2013	PAR, INC	059 TESTING MATERIALS	
		WRAT3 READING AND SPELLING WORD LIST CARDS (SET OF 2)	059-1000-614-239-0000-000-115 059-1000-614-239-0000-000-510	28.00 28.00
		WRAT3 BLUE TEST FORMS (PKG/25)	059-1000-614-239-0000-000-115 059-1000-614-239-0000-000-510	60.00 60.00
		WRAT3 TAN TEST FORMS (PKG/25)	059-1000-614-239-0000-000-115 059-1000-614-239-0000-000-510	60.00 60.00
		WRAT3 PROFILE/ANALYSIS FORMS (PKG25)	059-1000-614-239-0000-000-115 059-1000-614-239-0000-000-510	57.20 57.20
				Total Purchase Order
623	08/16/2013	SAM'S CLUB	052 COPY PAPER	
		052 COPY PAPER - 16000 REAMS FOR DISTRICT WIDE USE	000-2620-611-000-0000-000-052	36,384.00
				Total Purchase Order
624	08/16/2013	ALLIED GLASS INC.	053 DOOR FRAMES/MISC SUPPLIES	
		053 DOOR FRAMES/MISC SUPPLIES	000-2620-618-000-0000-000-053	1,000.00
				Total Purchase Order
625	08/16/2013	PERMA BOUND BOOKS	021 110 SEQUOYAH BOOKS	
		SEQUOYAH CHILDRENS 2014 BOOKS & PROCESSING	021-2220-641-100-0000-000-110	256.54
				Total Purchase Order
626	08/16/2013	RIVERSIDE PUBLISHING	059 TESTING MATIERALS	
		WOODCOCK INTERPRETATION AND INSTRUCTIONAL INTERVENTIONS PROGRAM (WIIIP) (INCLUDES SOFTWARE PROGRAM AND MANUAL) AND WJ III NU ACHIEVEMENT AND BATTERY FORM C	059-1000-614-239-0000-000-140 059-1000-614-239-0000-000-145	654.00 654.00
		ONE FOR CANYON RIDGE ONE FOR HORIZON		
		WJ III NU TESTS OF ACHIEVEMENT, FORM C/BRIEF BATTERY TEST RECORDS AND SUBJECT RESPONSE BOOKLETS (PKG. 25)	059-1000-614-239-0000-000-059	358.00
		SHIPPING CHARGES	059-1000-614-239-0000-000-059	210.60

General Fund 2013-2014
Detail Encumbrance Listing
As of 09/04/2013

PurOrder	Date	To Whom Issued / Detail Description	Po Description / Classification	
626	08/16/2013	RIVERSIDE PUBLISHING	059 TESTING MATIERALS	
			Total Purchase Order	2,316.60
627	08/16/2013	OFFICE DEPOT	DEPUTY SUPERINTENDENT SUPPLIES	
		Item # 532257 Black n' RedT Poly Notebook/Journal, 11 3/4" x 8 1/4", Black/Red, 70 Pages	050-2321-619-000-0000-000-050	102.48
			Total Purchase Order	102.48
628	08/16/2013	LONE STAR SAFETY AND SUPPLY, INC.	052 SAFETY CONES F/DW	
		052 PURCHASE 50 SAFETY CONES TO BE USED AROUND THE DISTRICT	000-2670-618-000-0000-000-052	750.00
			Total Purchase Order	750.00
629	08/19/2013	DEMCO INC.	021 125 Supplies	
		Electric pencil sharpener	021-2220-619-100-1050-000-125	48.89
		letter size file folders	021-2220-619-100-1050-000-125	34.59
		Avery 5260 laser printer labels	021-2220-619-100-1050-000-125	14.29
		Scoth Magic Tape	021-2220-619-100-1050-000-125	10.32
		Premium book tape	021-2220-619-100-1050-000-125	72.24
		pop-up notes refill	021-2220-619-100-1050-000-125	17.04
		Post-it pad labels	021-2220-619-100-1050-000-125	12.99
		gold foil library pencils	021-2220-619-100-1050-000-125	3.50
		reading star pencils	021-2220-619-100-1050-000-125	3.50
		Eric Carle pencils	021-2220-619-100-1050-000-125	3.50
		shipping	021-2220-619-100-1050-000-125	5.00
		Economy binder	021-2220-619-100-1050-000-125	5.19
		Yellow book labels	021-2220-619-100-1050-000-125	3.46
			Total Purchase Order	234.51
630	08/19/2013	FOLLETT EDUCATIONAL SERVICES	505 PURCHASE LIBRARY BOOKS	
		NEW BOOKS FOR LIBRARY, ORDER TO BE PLACED UPON RECEIPT OF PO ASST TITLES (ESTIMATE)	000-2220-641-100-0000-000-505	120.00
			Total Purchase Order	120.00
631	08/19/2013	PERMA BOUND BOOKS	505 PURCHASE BOOKS FOR LIBRARY	
		NEW BOOKS FOR LIBRARY, ORDER TO BE PLACED UPON RECEIPT OF PO ASST TITLES (ESTIMATE)	000-2220-641-100-0000-000-505	500.00
			Total Purchase Order	500.00
632	08/19/2013	HOBBY LOBBY	505 SUPPLIES SKILLS FOR LIVING	
		SUPPLIES FOR SKILLS FOR LIVING FOR 7TH & 8TH GRADE	000-1000-681-100-0000-000-505	75.00
		STUFFING, THREAD, NEEDLES, SEWING SUPPLIES, EMBROIDERY HOOPS		
			Total Purchase Order	75.00
633	08/19/2013	HOMELAND	505 SUPPLIES SKILLS FOR LIVING	
		SUPPLIES FOR SKILLS FOR LIVING 7TH & 8TH GRADES	000-1000-681-100-0001-000-505	400.00
		ITEMS PURCHASED WILL INCLUDE FLOUR, SUGAR, EGGS, CANNED BISCUITS, CHEESE, CHOCOLATE CHIPS, BAKING MIX, EGGS		36
			Total Purchase Order	400.00

General Fund 2013-2014
Detail Encumbrance Listing
As of 09/04/2013

PurOrder	Date	To Whom Issued / Detail Description	Po Description / Classification	
634	08/19/2013	WAL-MART- 6032202040025802	505 SUPPLIES SKILLS FOR LIVING	
		SUPPLIES FOR SKILLS FOR LIVING; 7TH & 8TH GRADES ITEMS PURCHASED TO INCLUDE: EGGS, FLOUR, SUGAR, POWDERED MILK,, CHOCOLATE CHIPS, SMALL EQUIPMENT, NEEDLES, PINS, THREAD, COOKING SUPPLIES, TEA-TOWELS, HOT PADS, ETC	000-1000-681-100-0000-000-505	300.00
Total Purchase Order				300.00
635	08/19/2013	HUNZICKER BROTHERS, INC.	055 CONTACTORS F/HS BAND HALL	
		055 PURCHASE 5 LIGHT CONTACTORS FOR THE HALLWAY AT THE HS BAND ROOM	000-2620-618-000-0000-000-055	178.53
Total Purchase Order				178.53
636	08/19/2013	OFFICE DEPOT	059 OFFICE SUPPLIES/PSYCHS LK	
		NATURE SAVER 1/5 CUT HANGING FILE FOLDERS, LETTE SIZE, 100% RECYCLED, GREEN, BOX OF 25	059-2140-619-239-0000-000-059	163.08
		QUARTET NATURAL CORK BULLETIN BOARD WITH OAK FRAME, 18"x24"	059-2140-619-239-0000-000-059	62.36
		REALSPACE PRO 26 1/2"D VERTICAL LETTER SIZE FILE CABINET, 2 BRAWERS, 30% RECYCLED, BLACK	059-2140-619-239-0000-000-059	749.95
		FORAY ALUMINUN FRAMED DRY ERASE BOARD WITH MARKER, 36" X 48", WHITE BOARD, SILVER FRAME	059-2140-619-239-0000-000-059	159.98
Total Purchase Order				1,135.37
637	08/19/2013	WAREHOUSE SUPPLIES	125 OFFICE SUPPLIES	
		OFFICE SUPPLIES (#10 MAILING ENVELOPES)	000-2410-619-000-0000-000-125	19.02
Total Purchase Order				19.02
638	08/19/2013	KAREN S BRIDGES	505 TRAVEL REIMBURSEMENT	
		COVERING SPORTING EVENTS AND ATTEND REQUIRED A.D. MEETINGS ACROSS THE STATE	000-2490-580-900-0000-000-505	300.00
Total Purchase Order				300.00
639	08/19/2013	CHAD ANDREW COLLIER	505 STUDENT SUPERVISION	
		TRAVEL REIMBURSEMENT TO COVER AWAY SPORTING EVENTS	000-2490-580-900-0000-000-505	350.00
Total Purchase Order				350.00
640	08/19/2013	JODY P MCELHANEY	505 TRAVEL REIMBURSEMENT	
		TRAVEL REIMBURSEMENT TO COVER AWAY ATHLETIC EVENTS	000-2490-580-900-0000-000-505	350.00
Total Purchase Order				350.00
641	08/19/2013	LINDA J WILKES	505 TRAVEL REIMBURSEMENT	
		TRAVEL REIMBURSEMENT TO COVER SUPERVISION FOR ATHLETIC EVENTS	000-2490-580-900-0000-000-505	450.00
Total Purchase Order				450.00
642	08/20/2013	OFFICE DEPOT	412 705 INSTRUCTIONA MATERIALS	
		INSTRUCTIONAL SHELVES	412-1000-654-317-8800-000-705	366.30
		INSTRUCTIONAL SHELVES	412-1000-654-317-8800-000-705	215.10
Total Purchase Order				581.40
643	08/20/2013	STAPLES BUSINESS ADVANTAGE 1561215	059 OFFICE SUPPLIES	
		AVERY PREMIUM COLLATED LEGAL EXHIBIT DIVIDERS, 1-25 TAB, WHITE, 8 1/2 X 11	059-2340-619-239-0000-000-059	355 .65
Total Purchase Order				55.65
644	08/20/2013	STAPLES BUSINESS ADVANTAGE 1561215	412 705 CLASSROOM SUPPLIES	

General Fund 2013-2014
Detail Encumbrance Listing
As of 09/04/2013

PurOrder	Date	To Whom Issued / Detail Description	Po Description / Classification	
644	08/20/2013	STAPLES BUSINESS ADVANTAGE 1561215	412 705 CLASSROOM SUPPLIES	
		Staples 2-Pocket Folder with Fasteners, Assorted Item: 905754 Model: 13367-CC	412-1000-619-317-8800-000-705	155.80
Total Purchase Order				155.80
645	08/20/2013	BLICK ART MATERIALS	043 705 CRAFTS	
		E-Z GRIP KNIFE	043-1000-681-100-2800-000-705	76.50
		BULK PACK #11 BLADE	043-1000-681-100-2800-000-705	18.75
		BULK PACK #16 BLADE	043-1000-681-100-2800-000-705	35.00
		ART GUM ERASERS BOX OF 24	043-1000-619-100-2800-000-705	17.01
		K 1 HOBBY KNIFE	043-1000-681-100-2800-000-705	22.44
		CLASSROOM PACK GLUE STICK	043-1000-619-100-2800-000-705	35.67
Total Purchase Order				205.37
646	08/20/2013	ETCHWORLD	043 705 CRAFTS TWO	
		BEIGE STENCIL VINYL MASKING 25 YRDS.	043-1000-681-100-2800-000-705	369.50
		CLEAR STENCIL VINYL MASKING 25 YRDS.	043-1000-681-100-2800-000-705	369.50
		GLASS CUTTER W/WOODEN HANDLE	043-1000-681-100-2800-000-705	8.85
		Shipping	043-1000-681-100-2800-000-705	30.00
Total Purchase Order				777.85
647	08/20/2013	LOWES CREDIT SERVICES	043 705 CRAFTS MATERIALS	
		GARDNER BOX OF 6 12" X 12" MIRROR TILES	043-1000-681-100-2800-000-705	56.94
Total Purchase Order				56.94
648	08/20/2013	COLTON HINES	0017 705 MB ELECTRONICS	
		MARCHING BAND ELECTRONICS COMPOSITION	007-1000-681-901-0000-000-705	1,500.00
Total Purchase Order				1,500.00
649	08/20/2013	TOM MCGILLEN	007 705 PERCUSSION ARRANGEMENT	
		MARCHING BAND PERCUSSION ARRANGEMENT	007-1000-681-901-0000-000-705	4,000.00
Total Purchase Order				4,000.00
650	08/20/2013	MRE CREATIVE DESIGN	007 705 MARCHING BAND DRILL	
		MARCHING BAND DRILL DESIGN	007-1000-681-901-0000-000-705	5,000.00
Total Purchase Order				5,000.00
651	08/20/2013	PITSCO	412 510 TECH ED SUPPLIES	
		50 pack PROPELLER BUGGY	412-1000-681-317-1220-000-510	165.00
		ECONOMY ROCKET PACK WITHOUT ENGINES	412-1000-681-317-1220-000-510	230.00
		1/2 A3-2T ROCKET ENGINES	412-1000-681-317-1220-000-510	23.85
		1/2 A3-4T ROCKET ENGINE	412-1000-681-317-1220-000-510	23.85
		UP AEROSPACE SPACELOFT ROCKET BULK PACK	412-1000-681-317-1220-000-510	110.00
		BALSA GLIDERS - GETTING STARTED PACKAGE	412-1000-681-317-1220-000-510	125.00
		TECH GLIDERS CONSUMABLE	412-1000-681-317-1220-000-510	180.00
		MODEL AIRPLANES - GETTING STARTED PACKAGE	412-1000-681-317-1220-000-510	120.00
		DELTA DART MODEL AIRPLANE 35 - PACK	412-1000-681-317-1220-000-510	159.00
		SUN ZOOM LITE - GETTING STARTED PACKAGE	412-1000-681-317-1220-000-510	498.00
		SOLAR DESIGNER - GETTING STARTED PACKAGE	412-1000-681-317-1220-000-510	538.00
		6 IN 1 EDUCATIONALSOLAR KIT	412-1000-681-317-1220-000-510	199.50
		BALSA WOOD MEGAPACK	412-1000-681-317-1220-000-510	179.85
		X300 SAFETY GLASSES - CLEAR	412-1000-681-317-1220-000-510	58.50
		SOLAR VEHICLES TEACHERS GUIDE	412-1000-681-317-1220-000-510	24.95
Total Purchase Order				2,635.50
652	08/20/2013	SIGNWAREHOUSE, INC.	412 705 INSTRUCTIONAL SUPPLIES	
		VINYL DECAL MATERIAL	412-1000-681-317-8800-000-705	273.77

General Fund 2013-2014
Detail Encumbrance Listing
As of 09/04/2013

PurOrder	Date	To Whom Issued / Detail Description	Po Description / Classification	
652	08/20/2013	SIGNWAREHOUSE, INC.	412 705 INSTRUCTIONAL SUPPLIES	
			Total Purchase Order	273.77
653	08/20/2013	WAL-MART- 6032202040025802	059 OFFICE SUPPLIES	
		GENERAL OFFICE SUPPLIES FOR SPECIAL SERVICES	059-2340-619-239-0000-000-059	1,000.00
			Total Purchase Order	1,000.00
654	08/20/2013	WAL-MART- 6032202040025802	412 705 Classroom supplies	
		Storage Containers, Markers & Classroom supplies	412-1000-619-314-8400-000-705	89.09
			412-1000-619-314-8400-000-705	660.91
			Total Purchase Order	750.00
655	08/20/2013	WAL-MART- 6032202040025802	412 705 MATERIALS/SUPPLIES	
		SUPPLIES, MATERIALS, EQUIPMENT FOR FACS CLASSES	412-1000-681-314-8400-000-705	700.00
			Total Purchase Order	700.00
656	08/21/2013	LDS BUILDING SPECIALITIES	053 DOOR SUPPLIES/MATERIALS	
		053 PURCHASE DOOR SUPPLIES/MATERIALS	000-2620-618-000-0000-000-053	198.00
			000-2620-618-000-0000-000-053	802.00
			Total Purchase Order	1,000.00
657	08/21/2013	VETS PLUMBING	055 VACUUM SEPTIC TANK	
		FOUND FULL SEPTIC TANK NEAR OLD VO-AG BUILDING THAT NEEDS TO BE CLEANED OUT.	000-2620-437-000-0000-000-055	1,000.00
			Total Purchase Order	1,000.00
658	08/21/2013	APPLE INC.	469 705 LOTTERY MONEY	
		APPLE TV MD199LL/A	469-1000-653-317-8800-000-705	99.00
		LIGHTNING TO DIGITAL AV ADAPTER MD826ZM/A	469-1000-653-317-8800-000-705	343.00
			Total Purchase Order	442.00
659	08/21/2013	DELL COMPUTER CORP	572 110 ELL LAPTOP	
		LATITUDE E 5530 E QUOTE # 1020392413180	572-1000-653-410-1310-000-110	1,032.35
			Total Purchase Order	1,032.35
660	08/21/2013	DANIEL ADKISSO	209 705 FALL GUARD COMPOSITION	
		ALL FALL CHOREOGRAPHY FOR GUARD	209-1000-681-901-0000-000-705	1,500.00
			Total Purchase Order	1,500.00
661	08/21/2013	LONE STAR PERCUSSION	209 705 INSTRUMENT REPAIR	
		RIBBON CRASHER MOUNT FOR MARCHING SNARE DRUM	209-1000-681-901-0000-000-705	150.00
			Total Purchase Order	150.00
662	08/21/2013	TOM MCGILLEN	209 705 INSTRUMENT REPAIR	
		FALL PERCUSSION DRUM HEAD PACKAGE- THIS IS REPAIR AND MAINTENANCE FOR ALL MARCHING DRUMS	209-2640-655-901-0000-000-705	1,150.00
			Total Purchase Order	1,150.00
663	08/21/2013	PENDER'S MUSIC COMPANY	209 705 BEG.OF YEAR MUSIC	
		BEGINNING OF YEAR MUSIC/CURRICULUM FOR CONCERT AND JAZZ BANDS	209-1000-681-901-0000-000-705	1,000.00
			Total Purchase Order	1,000.00
664	08/21/2013	GEOFFREY CLIFTON	209 705 INSTRUMENT REPAIR	39
		CONCERT INSTRUMENT REPAIR AND MAINTENANCE (48 INSTRUMENTS	209-2640-655-901-0000-000-050	3,240.00
			Total Purchase Order	3,240.00

General Fund 2013-2014
Detail Encumbrance Listing
As of 09/04/2013

PurOrder	Date	To Whom Issued / Detail Description	Po Description / Classification	
665	08/21/2013	HEINEMANN	511 050 PD BOOKS	
		PATHWAYS TO COMMON CORE	511-2213-641-429-1139-000-105	1,115.00
		BOOKS TO BE USED FOR COMMON CORE PD	511-2213-641-429-1139-000-120	1,469.79
		15 PACKS OF 15 BOOKS	511-2213-641-429-1139-000-125	1,368.41
			511-2213-641-429-1139-000-135	1,115.00
		CREEK 62 BOOKS		
		CENTENNIAL 49 BOOKS		
		ME 49 BOOKS		
		TRAILS 65 BOOKS		
		SHIPPING COSTS	511-2213-641-429-1139-000-050	405.46
Total Purchase Order				5,473.66
666	08/21/2013	ROSETTA STONE, LTD	571/572 050 ELL ONLINE SUBSRIP	
		ROSETTA STONE CLASSROOM - ENGLISH VERSION 3	571-1000-530-410-0000-000-050	11,073.28
		ONLINE SUBSCRIPTION - 125 FLEXIBLE LICENSE	572-1000-530-410-0000-000-050	1,426.72
		SUBSCRIPTIONS WHICH ALSO INCLUDES UNLIMITED		
		ACCESS TO ADMINISTRATIVE TOOLS, ROSETTA STONE		
		MANAGER AND TECHNICAL SUPPORT FOR ONE YEAR		
Total Purchase Order				12,500.00
667	08/21/2013	CALAH CHRISTINE LYNES	050 ELL TEACHER MILEAGE	
		ESTIMATED TRAVEL FOR ELL TEACHER MILEAGE FOR	180-1000-580-410-0000-000-050	350.00
		2013-2014 YEAR		
Total Purchase Order				350.00
668	08/21/2013	CAROLINA BIOLOGICAL SUPPLY	SCIENCE SUPPLIES - HORIZON	
		HORIZON - SCIENCE SUPPLIES	050-1000-681-100-5000-000-140	91.00
		VOLUME FINDER CLASS SET 752676		
		STOPWATCHES 962107	050-1000-681-100-5000-000-140	78.00
		LAB APRONS, CHILD SIZE 706244	050-1000-681-100-5000-000-140	146.55
		TRIPLE BEAM BALANCE 702020	050-1000-681-100-5000-000-140	95.00
		RULER, PLASTIC SCALE 702611	050-1000-681-100-5000-000-140	30.15
		POLYSTYRENE, DISPOSABLE STERILE PETRI DISHES	050-1000-681-100-5000-000-140	25.00
		NITRITE DISPOSABLE GLOVES 706335	050-1000-681-100-5000-000-140	17.95
		IODINE TINCTURE LABORATORY GRADE 869121	050-1000-681-100-5000-000-140	6.80
		LUMBERICULUS VARIEGATUS, LIVING CULTURE 141720	050-1000-681-100-5000-000-140	17.00
		VINEGAR EELS RE133266	050-1000-681-100-5000-000-140	7.36
		PROTOZOA SURVEY SET, LIVING 131008	050-1000-681-100-5000-000-140	84.50
		TICKLE ME PLANT SEET PACKET 158150	050-1000-681-100-5000-000-140	29.94
		DAPHNIA MAGNA, LIVING 142330	050-1000-681-100-5000-000-140	17.50
		PREPARED SPIROGYRA SLIDES 296578	050-1000-681-100-5000-000-140	39.00
		DON'T BUG ME SLIDE SET 293519	050-1000-681-100-5000-000-140	210.00
		METER STICKS 702620	050-1000-681-100-5000-000-140	153.00
		SLIDES LJ632970	050-1000-681-100-5000-000-140	19.68
		SAFETY GLASSES RE646703	050-1000-681-100-5000-000-140	99.09
		BEAKERS - PYREX RE721219	050-1000-681-100-5000-000-140	91.20
		ERLENMEYER FLASKS/250MI RE721150	050-1000-681-100-5000-000-140	58.30
		SHIPPING 10%	050-1000-681-100-5000-000-140	132.00
Total Purchase Order				1,449.02
669	08/21/2013	CAROLINA BIOLOGICAL SUPPLY	SCIENCE SUPPLIES - CANYON RIDG	
		CANYON RIDGE - SCIENCE SUPPLIES	050-1000-681-100-5000-000-145	91.00
		VOLUME FINDER CLASS SET 752676		
		STOPWATCHES 962107	050-1000-681-100-5000-000-145	78.00
		LAB APRONS, CHILD SIZE 27X36 706244	050-1000-681-100-5000-000-145	146.55
		TRIPLE BEAM BALANCE 702020	050-1000-681-100-5000-000-145	95.00
		RULER, PLASTIC SCALE 702611	050-1000-681-100-5000-000-145	30.15
		POLYSTYRENE, DISPOSABLE STERILE PETRI DISHES	050-1000-681-100-5000-000-145	25.00
		741246		

General Fund 2013-2014
Detail Encumbrance Listing
As of 09/04/2013

PurOrder	Date	To Whom Issued / Detail Description	Po Description / Classification	
669	08/21/2013	CAROLINA BIOLOGICAL SUPPLY	SCIENCE SUPPLIES - CANYON RIDG	
		NITRITE DISPOSABLE GLOVES 706335	050-1000-681-100-5000-000-145	17.95
		IODINE TINCTURE LABORATORY GRADE 869121	050-1000-681-100-5000-000-145	6.80
		LUMBERICULU VARIEGATUS, LIVING CULTURE 141720	050-1000-681-100-5000-000-145	17.00
		VINEGAR EELS RE-133266	050-1000-681-100-5000-000-145	7.36
		PROTOZOA SURVEY SET, LIVING 131008	050-1000-681-100-5000-000-145	84.50
		TICKLE ME PLANT SEE PACKET 158150	050-1000-681-100-5000-000-145	29.94
		DAPHNIA MAGNA, LIVING 142330	050-1000-681-100-5000-000-145	17.50
		PREPARED SPIROGYRA SLIDES 296578	050-1000-681-100-5000-000-145	39.00
		DON'T BUG ME SLIDE SET 293519	050-1000-681-100-5000-000-145	210.00
		METER STICKS 702620	050-1000-681-100-5000-000-145	153.00
		SLIDES LJ632973	050-1000-681-100-5000-000-145	19.68
		SAFETY GLASSES RE646703	050-1000-681-100-5000-000-145	99.09
		BEAKERS - PYREX RE721219	050-1000-681-100-5000-000-145	91.20
		ERIENMEYER FLASKS/250 MI RE721150	050-1000-681-100-5000-000-145	58.30
		SHIPPING & HANDLING 10%	050-1000-681-100-5000-000-145	132.00
			Total Purchase Order	1,449.02
670	08/21/2013	SCHOOL SPECIALTY	SCIENCE SUPPLIES - HORIZON	
		HORIZON SCIENCE SUPPLIES	050-1000-681-100-5000-000-140	14.67
		SPRAY BOTTLES 6 - 205539		
		CENTIMETER CUBES 500 PER PACK - 236330	050-1000-681-100-5000-000-140	44.91
		SPONGES 85851	050-1000-681-100-5000-000-140	41.79
		SHIPPING 10%	050-1000-681-100-5000-000-140	10.14
			Total Purchase Order	111.51
671	08/21/2013	SCHOOL SPECIALTY	SCIENCE SUPPLIES - CANYON RIDG	
		CANYON RIDGE SCIENCE SUPPLIES	050-1000-681-100-5000-000-145	14.67
		SPRAY BOTTLES 6 - 205539		
		CENTIMETER CUBES - 500 PER PACK 236330	050-1000-681-100-5000-000-145	44.91
		SPONGES 85851	050-1000-681-100-5000-000-145	41.79
		SHIPPING 10%	050-1000-681-100-5000-000-145	10.14
			Total Purchase Order	111.51
672	08/21/2013	GRAINGER	SCIENCE SUPPLIES - HORIZON	
		HORIZON SCIENCE SUPPLIES	050-1000-681-100-5000-000-140	467.46
		EYEWASH, FAUCET mOUNT FOR STANDARD FAUCET 2DCJ8		
			Total Purchase Order	467.46
673	08/21/2013	GRAINGER	SCIENCE SUPPLIES - CANYON RIDG	
		CANYON RIDGE	050-1000-681-100-5000-000-145	467.46
		EYEWASH, FAUCET MOUNT, FOR STANDARD FAUCET 4-1/4 W, 2 1/4 D 2DCJ8		
			Total Purchase Order	467.46
674	08/21/2013	LAKESHORE LEARNING	SCIENCE SUPPLIES - HORIZON	
		HORIZON SCIENCE SUPPLIES	050-1000-681-100-5000-000-140	159.98
		STUDENT SAFETY GOGGLES LA217		
		PREPARED SLIDES LC3540X	050-1000-681-100-5000-000-140	49.99
		PRECISION SCHOOL BALANCE WITH METRIC WEIGHTS DA118	050-1000-681-100-5000-000-140	239.94
		SHIPPING 10%	050-1000-681-100-5000-000-140	44.99
			Total Purchase Order	494.90
675	08/21/2013	LAKESHORE LEARNING	SCIENCE SUPPLIES - CANYON RIDG	41
		CANYON RIDGE SCIENCE SUPPLIES	050-1000-681-100-5000-000-145	159.98
		STUDENT SAFETY GOGGLES SET OF 36 LA217		
		PREPARED SLIDES - COMPLETE SET LC3540X	050-1000-681-100-5000-000-145	49.99

General Fund 2013-2014
Detail Encumbrance Listing
As of 09/04/2013

PurOrder	Date	To Whom Issued / Detail Description	Po Description / Classification	
675	08/21/2013	LAKESHORE LEARNING	SCIENCE SUPPLIES - CANYON RIDG	
		PRECISION SCHOOL BALANCE WITH METRIC WEIGHTS DA118	050-1000-681-100-5000-000-145	239.94
		SHIPPING 10%	050-1000-681-100-5000-000-145	44.99
			Total Purchase Order	494.90
676	08/21/2013	NASCO	SCIENCE SUPPLIES - HORIZON	
		HORIZON SCIENCE SUPPLIES	050-1000-681-100-5000-000-140	299.00
		SUNLIGHTER PLANT DISPLAY STAND SB151180M		
		SUNLIGHTER FLORESCENT FIXTURE SB15185M	050-1000-681-100-5000-000-140	526.00
		IMMERSION THERMOMETERS - 10 TO 110C, 0 TO 230 F SA08157B	050-1000-681-100-5000-000-140	67.05
		GRADUATED CYLINDER SET EL11056B	050-1000-681-100-5000-000-140	139.30
		METERSTICKS, BRASS ENDS SB12161B	050-1000-681-100-5000-000-140	139.02
		SHIPPING 10%	050-1000-681-100-5000-000-140	117.40
			Total Purchase Order	1,287.77
677	08/21/2013	NASCO	SCIENCE SUPPLIES - CANYON RIDG	
		CANYON RIDGE SCIENCE SUPPLIES	050-1000-681-100-5000-000-145	299.00
		SUNLIGHTER PLANT DISPLAY STAND SB151180M		
		SUNLIGHTER FLORESCENT FIXTURE SB15185M	050-1000-681-100-5000-000-145	526.00
		IMMERSION THERMOMETERS - 20 TO 110 C, 0 TO 230 F SA08157B	050-1000-681-100-5000-000-145	67.05
		GRADUATED CYLINDER SET EL11056B	050-1000-681-100-5000-000-145	139.30
		METERSTICKS, BRASS ENDS SB12161B	050-1000-681-100-5000-000-145	139.02
		SHIPPING 10%	050-1000-681-100-5000-000-145	117.40
			Total Purchase Order	1,287.77
678	08/21/2013	SCHOOL SPECIALTY	SCIENCE SUPPLIES - HORIZON	
		HORIZON SCIENCE SUPPLIES	050-1000-681-100-5000-000-140	35.96
		UNITED SCIENTIFIC - ECONOMY PLASTIC BEAKERS 025-5420		
		C&A FLINT GLASS DROPPER PIETTES, 3 INCH 569723	050-1000-681-100-5000-000-140	11.94
		TWEEZERS 444185	050-1000-681-100-5000-000-140	86.04
		MEASURING SPOONS - METRIC CONVERSION 193-7912	050-1000-681-100-5000-000-140	35.82
		DISPOSABLE GLOVES SMALL 80571	050-1000-681-100-5000-000-140	39.96
		DISPOSABLE GLOVES MEDIUM 1004986	050-1000-681-100-5000-000-140	11.98
		ALL PURPOSE LAB CART 574109	050-1000-681-100-5000-000-140	611.85
		MEASURING CUPS - METRIC CONVERSION 1015599	050-1000-681-100-5000-000-140	58.50
		TRUNDLE WHEEL 573145	050-1000-681-100-5000-000-140	79.80
		SHIPPING 10%	050-1000-681-100-5000-000-140	97.18
			Total Purchase Order	1,069.03
679	08/21/2013	SCHOOL SPECIALTY	SCIENCE SUPPLIES - CANYON RIDG	
		CANYON RIDGE SCIENCE SUPPLIES	050-1000-681-100-5000-000-145	35.96
		UNITED SCIENTIFIC ECONOMY PLASTIC BEAKERS SET OF 5 025-5420		
		C&A FLINT GLASS DROPPER PIPETTES, 3 INCH 569723	050-1000-681-100-5000-000-145	11.94
		TWEEZERS 444185	050-1000-681-100-5000-000-145	86.04
		MEASURING SPOONS - METRIC CONVERSION 193-7912	050-1000-681-100-5000-000-145	35.82
		DISPOSABLE GLOVES SMALL 80571	050-1000-681-100-5000-000-145	39.96
		DISPOSABLE GLOVES - MEDIUM 1004986	050-1000-681-100-5000-000-145	11.98
		ALL PURPOSE LAB CART 574109	050-1000-681-100-5000-000-145	611.85
		MEASURING CUPS - METRIC CONVERSION 1015599	050-1000-681-100-5000-000-145	58.50
		TRUNDLE WHEEL 573145	050-1000-681-100-5000-000-145	79.80
		SHIPPING 10%	050-1000-681-100-5000-000-145	97.18
			Total Purchase Order	1,069.03
680	08/21/2013	HOMELAND	510 SKILLS FOR LIVING SUPPLIES	

General Fund 2013-2014
Detail Encumbrance Listing
As of 09/04/2013

PurOrder	Date	To Whom Issued / Detail Description	Po Description / Classification	
680	08/21/2013	HOMELAND	510 SKILLS FOR LIVING SUPPLIES	
		salt, shortening, brown sugar, milk, eggs, flour, Chocolate chips,	014-1000-681-100-3400-000-510	387.09
		frozen strawberries, yogurt, bananas, crescent rolls, little smokies,	014-1000-681-100-3400-000-510	212.91
		orange juice, bread, pepperonis, mozzarella cheese slives,		
		spaghetti sauce, soft margarine, bisquick, cooking spray, sugar		
Total Purchase Order				600.00
681	08/21/2013	WAL-MART- 6032202040025802	510 SKILLS FOR LIVING SUPPLIES	
		4 BLENDERS, 2 WAFFLE IRONS, 8 COOKIE SHEETS, 6	014-1000-681-100-3400-000-510	600.00
		COOLING RACKS, 12 CUSTARD CUPS		
Total Purchase Order				600.00
682	08/21/2013	AWIM	412 510 TECH ED SUPPLIES	
		motorized toy car challenge	412-1000-653-317-1220-000-510	460.00
Total Purchase Order				460.00
683	08/21/2013	C & H DISTRIBUTORS	057 CUSTODIAL SUPPLIES	
		2 ONLY 3X5 BLACK 32760 ECO CARPET MATS	000-2620-618-000-0000-000-057	196.00
		2 ONLY 3X10 BLACK 32761 CARPET MAT	000-2620-618-000-0000-000-057	402.00
Total Purchase Order				598.00
684	08/21/2013	CREATIVE MATHEMATICS	511-125 CLASS MATERIALS	
		MATH DRILLS TO THRILL CC1166	511-1000-641-429-2231-000-125	100.00
		POWERFUL NUMBERS 1-100 CC1140	511-1000-641-429-2231-000-125	100.00
		PLACE VALUE WITH PIZAZZ CC1143	511-1000-641-429-2231-000-125	100.00
		SKIP COUNTING CD CC1111	511-1000-615-429-2231-000-125	60.00
		MULTIPLICATION CD CC1110	511-1000-615-429-2231-000-125	60.00
		SHIPPING 15%	511-1000-615-429-2231-000-125	21.00
Total Purchase Order				441.00
685	08/21/2013	FOLLETT LIBRARY RESOURCES	021 110 PAPERBACK BOOKS	
		PAPERBACK BOOKS - SEQUOYAH -5 TITLES	021-2220-641-100-0000-000-110	103.84
Total Purchase Order				103.84
686	08/21/2013	HANDWRITING WITHOUT TEARS	059 TRAILS / OT/PT	
		LETTERS AND NUMERS FOR ME	059-2135-681-239-0000-000-120	123.75
		MY PRINTING BBOK	059-2135-681-239-0000-000-120	123.75
		PRINTING POWER	059-2135-681-239-0000-000-120	82.50
		MY FIRST SCHOOL BOOK	059-2135-681-239-0000-000-120	82.50
		ROCK-WRAP-TAP-LEARN CD	059-2135-681-239-0000-000-120	27.50
		WIDE DOUBLE LINE NOTEBOOK PAPER	059-2135-681-239-0000-000-120	11.50
		SHIPPING 10%	059-2135-681-239-0000-000-120	45.15
Total Purchase Order				496.65
687	08/21/2013	JUNIOR LIBRARY GUILD	021 510 BOOKS FOR STUDENTS	
		BOOK SUBSCRIPTION RENEWAL	021-2220-641-100-0000-000-510	3,594.00
		NONFICTION HISTORY (6-8), NONFICTION SCIENCE (6-8), SOCIAL STUDIES (6-8)B LEVEL, B+LEVEL, C LEVEL, C+ LEVEL, FM LEVELFANTASY/SCIENCE, GM LEVEL GRAPHIC NOVELS, HM LEVEL HIGH INTEREST MS, MN LEVEL MYSTERY AND ADVENTURE MS/HS, NONFICTION MS/HS, SPORTS MS, NH NONFICTION HS, SH LEVEL SPORTS HS, Y LEVEL YOUNG ADULTS, Y+LEVEL YOUNG ADULT SHELF READY PROCESSING		
		FREE SHIPPING		43
Total Purchase Order				3,594.00
688	08/21/2013	TRU-GREEN	064 802 FIELD MAINTENANCE	

General Fund 2013-2014
Detail Encumbrance Listing
As of 09/04/2013

PurOrder	Date	To Whom Issued / Detail Description	Po Description / Classification	
688	08/21/2013	TRU-GREEN	064 802 FIELD MAINTENANCE	
		FIELD MAINTENANCE ON SOCCER FIELD	064-2630-710-802-0000-000-705	1,410.00
Total Purchase Order				1,410.00
689	08/21/2013	JL HEIN SERVICE INC	110 TECHNOLOGY	
		VGA CABLES FOR SMARTBOARDS	000-1000-653-100-0000-000-110	276.00
Total Purchase Order				276.00
690	08/21/2013	OFFICE DEPOT	572 145 PRINTER ANITA CONWAY	
866887	EPSON	WF-2540 PRINTER - ANITA CONWAY	572-1000-653-410-1310-000-145	89.99
804058	EPSON	BL INK - ANITA CONWAY	572-1000-613-410-1310-000-145	28.61
821347	EPSON	CYAN INK - ANITA CONWAY	572-1000-613-410-1310-000-145	16.21
821374	EPSON	MAGENTA INK - ANITA CONWAY	572-1000-613-410-1310-000-145	16.21
821716	EPSON	YELLOW INK - ANITA CONWAY	572-1000-613-410-1310-000-145	16.21
Total Purchase Order				167.23
691	08/21/2013	OFFICE DEPOT	572 110 PRINTER CALAH LYNES	
866887	EPSON	WF-2540 PRINTER - CALAH LYNES	572-1000-653-410-1310-000-110	89.99
804058	EPSON	200XL BLACK INK - CALAH LYNES	572-1000-613-410-1310-000-110	28.61
821347	EPSON	200XL CYAN INK - CALAH LYNES	572-1000-613-410-1310-000-110	16.21
821374	EPSON	200XL MAGENTA INK - CALAH LYNES	572-1000-613-410-1310-000-110	16.21
821716	EPSON	200XL YELLOW INK - CALAH LYNES	572-1000-613-410-1310-000-110	16.21
Total Purchase Order				167.23
692	08/22/2013	SCHOOL SPECIALTY	110 CLASSROOM SUPPLIES	
		RIVERSIDE CONST. PAPER WHITE	000-1000-611-100-0000-000-110	1.27
		CONST PAPER HOLIDAY GREEN	000-1000-611-100-0000-000-110	1.27
		CHART PAPER	000-1000-611-100-0000-000-110	8.61
		DRY ERASE PUPIL BOARDS	000-1000-619-100-0000-000-110	15.97
		EXPO DRY ERASE KIT	000-1000-619-100-0000-000-110	17.87
		EXPO DRY ERASE KIT	000-1000-619-100-0000-000-110	14.77
		PAPER PRO DESK TOP STAPLER	000-1000-619-100-0000-000-110	20.37
		PAPERCLIPS	000-1000-619-100-0000-000-110	0.27
		PAPER CLIPS	000-1000-619-100-0000-000-110	0.57
		COLORED PAPER	000-1000-611-100-0000-000-110	7.97
		COLORED PAPER	000-1000-611-100-0000-000-110	7.97
Total Purchase Order				96.91
693	08/22/2013	LIBERTON INC.	110 SCHOOL SUPPLY	
		BLINDS FOR SPED ROOM AND OFFICE WINDOWS	000-2620-654-000-0000-000-110	300.00
Total Purchase Order				300.00
694	08/22/2013	METRO MEDICAL SUPPLY, INC.	059 SPECIAL SERVICES SUPPLIES	
		PACIFICA TRI-POLY NON-LATEX EXAM GLOVES (case of 1000) LARGE	059-2132-616-239-0000-000-135	50.69
Total Purchase Order				50.69
695	08/22/2013	WCEPS	572 140/145 ELL WIDA STANDARD	
		WIDA 2012 AMPLIFICATION OF THE ENGLISH LANGUAGE DEVELOPMENT STANDARDS	572-1000-681-410-1310-000-140	14.00
		WIDA 2012 AMPLIFICATION OF THE ENGLISH LANGUAGE DEVELOPMENT STANDARDS	572-1000-681-410-1310-000-145	14.00
		SHIPPING & HANDLING	572-1000-681-410-1310-000-145	44.00
Total Purchase Order				42.00
696	08/22/2013	SAM'S CLUB	110 NURSES OFFICE SUPPLIES	
			000-2132-616-100-0000-000-110	19.96

General Fund 2013-2014
Detail Encumbrance Listing
As of 09/04/2013

PurOrder	Date	To Whom Issued / Detail Description	Po Description / Classification	
696	08/22/2013	SAM'S CLUB	110 NURSES OFFICE SUPPLIES	
		TUMS		
		IBUPROFIN	000-2132-616-100-0000-000-110	12.98
		SALTINES	000-2132-616-100-0000-000-110	15.56
		MINTS	000-2132-616-100-0000-000-110	13.96
			Total Purchase Order	62.46
697	08/22/2013	OFFICE DEPOT	561 110 TEACHER SUPPLIES	
		GEAR HEAD WIRELESS KEYBOARD #266685	561-1000-653-424-0000-000-110	29.99
		SWINGLINE 545 STAPLER #908210	561-1000-619-424-0000-000-110	7.59
		POST-IT FLAGS #265333	561-1000-619-424-0000-000-110	6.26
		STORAGE TRAY #522330	561-1000-619-424-0000-000-110	9.00
		FILE SORTER #868068	561-1000-619-424-0000-000-110	23.39
		MESSAGE BOOK #848861	561-1000-619-424-0000-000-110	4.81
		ORBITZ RETRACTABLE BLUE PEN #528080	561-1000-619-424-0000-000-110	23.32
		BIC ROUND STIC #396521	561-1000-619-424-0000-000-110	4.00
		PAPER MATE FLAIR #396521	561-1000-619-424-0000-000-110	22.46
		FLAIR RED #898858	561-1000-619-424-0000-000-110	3.74
		HANGING FILE FOLDERS LEGAL #195168	561-1000-619-424-0000-000-110	74.07
		POP UP DISPENSER #717261	561-1000-619-424-0000-000-110	10.44
			Total Purchase Order	219.07
698	08/22/2013	OKLAHOMA EMPLOYMENT SEC. COMM.	050 UNEMPLOYMENT EXPENSES	
		UNEMPLOYMENT EXPENSES	050-1000-271-100-4000-210-705	2,859.83
			050-1000-271-100-4000-210-705	27,140.17
			Total Purchase Order	30,000.00
699	08/22/2013	THOMPSON EDUCATIONAL FURNISHINGS	060 LAMINATE DESK TOPS	
		060 SCHOLAR CRAFT LAMINATE DESK TOPS	000-2620-654-000-0000-000-060	372.00
			Total Purchase Order	372.00
700	08/22/2013	OSPMA	060 OSPMA CONVENTION	
		055 DUES AND FEES	000-2620-810-000-0000-000-055	65.00
			Total Purchase Order	65.00
701	08/22/2013	KNOX COMPANY	053 KNOX PADLOCKS	
		PURCHASE FOUR (4) KNOX PAD LOCKS FOR HORIZON AND HS CAMPUS AREA PER MFD REQUEST	000-2670-618-000-0000-000-053	354.00
			Total Purchase Order	354.00
702	08/22/2013	ID SPECIALTIES, INC	067 TECHNOLOGY	
		ZEBRA RIBBON FOR JANA CLASON - FOR PERSONNEL BADGES	000-2572-619-000-0000-000-067	160.00
		ZEBRA 800033-840 COLOR RIBBON		45
			Total Purchase Order	160.00
703	08/22/2013	DELL COMPUTER CORP	060 COLOR PRINTER AND TONER	

General Fund 2013-2014
Detail Encumbrance Listing
As of 09/04/2013

PurOrder	Date	To Whom Issued / Detail Description	Po Description / Classification	
703	08/22/2013	DELL COMPUTER CORP	060 COLOR PRINTER AND TONER	
		YELLOW TONER CARTRIDGE	000-2620-611-000-0000-000-060	132.98
		CYAN TONER CARTRIDGE	000-2620-611-000-0000-000-060	132.98
		MAGENTA TONER CARTRIDGE	000-2620-611-000-0000-000-060	132.98
		BLACK TONER CARTRIDGE	000-2620-611-000-0000-000-060	132.98
Total Purchase Order				756.91
704	08/22/2013	SCHOOL SPECIALTY	110 CLASSROOM SUPPLIES	
		HOLE PUNCH	000-1000-619-100-0000-000-110	13.27
		SCISSORS	000-1000-619-100-0000-000-110	4.17
		STAPLES	000-1000-619-100-0000-000-110	1.74
		STAPLER	000-1000-619-100-0000-000-110	16.77
		TAPE DISPENSER AND REFILLS	000-1000-619-100-0000-000-110	28.87
		CONTACT PAPER	000-1000-611-100-0000-000-110	6.67
		PLAY DOUGH ROLLERS	000-1000-619-100-0000-000-110	3.37
		ALPHABET SET	000-1000-619-100-0000-000-110	7.37
		DESK ORGANIZER	000-1000-619-100-0000-000-110	17.67
Total Purchase Order				99.90
705	08/22/2013	SCHOOL SPECIALTY	110 OFFICE SUPPLIES	
		FINGER TIP GRIPS	000-1000-619-100-0000-000-110	7.41
		CHALK DUSTLESS ASST PACK	000-1000-619-100-0000-000-110	3.77
		CHALK DUSTLESS ASST PACK	000-1000-619-100-0000-000-110	0.47
		CHALK DUSTLESS YELLOW	000-1000-619-100-0000-000-110	0.47
		TAPE DISPENSER	000-1000-619-100-0000-000-110	3.77
		TAPE DISPENSER (PINK)	000-1000-619-100-0000-000-110	3.77
Total Purchase Order				19.66
706	08/22/2013	DISCOUNT SCHOOL SUPPLY	110 CLASSROOM SUPPLIES	
		COLORATIONS SIMPLY WASHABLE TEMPERA PAINT (16 OZ. SET OF 11 COLORS)	000-1000-681-100-0000-000-110	43.78
		COLORATIONS CONSTRUCTION PAPER SMART PACK	000-1000-611-100-0000-000-110	15.99
		COLORATIONS BRIGHT CONSTRUCTION PAPER SMART PACK	000-1000-611-100-0000-000-110	15.99
		12 PENCIL SHARPENERS	000-1000-619-100-0000-000-110	20.97
Total Purchase Order				96.73
707	08/22/2013	DEMCO INC.	050 145 AUDIO CART FOR CRI	
		LUXOR ADJUSTABLE HEIGHT AV CART	050-1000-654-100-0001-000-145	169.99
		MODEL: P153-0077		
		SHIPPING AND HANDLING	050-1000-654-100-0001-000-145	25.00
Total Purchase Order				194.99
708	08/22/2013	QUILL	050 145 SCHOOL SUPPLIES	
		X-ACTO HEAVY DUTY WOOD TRIMMER 24 " MODEL 26364	050-1000-681-100-0001-000-145	319.98
Total Purchase Order				319.98
709	08/22/2013	OFFICE DEPOT	572 145 ELL CURRICULUM SUPPLIE	
		CYBER ACOUSTICS AC-840 MONO USB HEADSET #112278	572-1000-681-410-1310-000-145	269.90
		ADDRESS LABELS #612011	572-1000-681-410-0000-000-145	36.00
		NENNAH HEAVEYWEIGHT EXACT INDEX CARD STOCK GREEN #477562	572-1000-611-410-0000-000-145	35.61
Total Purchase Order				341.51
710	08/22/2013	OFFICE DEPOT	064 CLIPP SUPPLIES	

General Fund 2013-2014
Detail Encumbrance Listing
As of 09/04/2013

PurOrder	Date	To Whom Issued / Detail Description	Po Description / Classification	
710	08/22/2013	OFFICE DEPOT	064 CURR SUPPLIES	
		18 BOXES OF 100 SMEAD COLOR FILE FOLDERS LETTER SIZE 1/3 CUT, BRIGHTS ITEM #116253	000-2212-619-100-0000-000-064	251.82
		STACY - PLEASE MAKE SURE THE OFFICE DEPOT BOXES ARE MARKED TO STACY EDWARDS ATTENTION. THANK YOU!		
Total Purchase Order				251.82
711	08/23/2013	WANDA DENISE BLACK	021 125 Library remodel	
		Upper Case Living Vinyl lettering designs for library, "Oh the Places You'll Go", "The More you Read...". "Make each day a story"	021-2220-682-100-1050-000-125	204.55
		Shipping	021-2220-540-100-1050-000-125	20.00
Total Purchase Order				224.55
712	08/23/2013	OFFICE DEPOT	572 115 ELL SUPPLIES	
		HEAVY DUTY CABINET DOLLY DOVE REY #995124	572-1000-619-410-1310-000-115	99.99
Total Purchase Order				99.99
713	08/23/2013	STAPLES BUSINESS ADVANTAGE 1561215	572 115 ELL SUPPLIES	
		HIRSH COMMERCIAL VERTICAL CABINET MOVER #805671	572-1000-619-410-1310-000-115	24.99
Total Purchase Order				24.99
714	08/23/2013	TOWER TECH, INC	055 COOLING TWR FAN/MOTOR	
		055 PURCHASE A FAN AND MOTOR FOR THE COOLING TOWER AT CREEK ELEMENTARY	000-2620-656-000-0000-000-055	3,000.00
Total Purchase Order				3,000.00
715	08/23/2013	WESTERN HILLS GUEST RANCH/ SEQUOYAH	060 LODGING F/BILL DADY	
		060 LODGING FOR THE OSPMA CONVENTION IN WAGGONER, OK -- BILL DADY WILL BE ATTENDING AND IS STAYING ONE NIGHT, THE CONVENTION IS SEPT 25,26,27, MR DADY WILL BE STAYING SPET 25TH AND RETURNING BACK ON SEPT 26TH EVENING	000-2573-582-000-0000-000-060	72.00
Total Purchase Order				72.00
716	08/23/2013	APPLE INC.	023-120 PRINCIPAL OFFICE	
		APPLE LOGITECH ULTRATHIN IPAD KEYBOARD	023-2410-653-100-0000-000-120	199.90
Total Purchase Order				199.90
717	08/23/2013	APPLE INC.	110 TECH INSTRUCTION	
		KANEX ATV PRO KDMI TO VGA ADAPTER WITH AUDIO SUPPORT	000-1000-653-100-0000-000-110	59.95
Total Purchase Order				59.95
718	08/23/2013	WAREHOUSE TECHNOLOGY	060 INK CARTRIDGES	
		PURCHASE 2 INK CARTRIDGES FOR JOHNITA'S PRINTER	000-2620-611-000-0000-000-060	66.12
		PURCHASE 2 INK TONER CARTRIDGES	000-2620-611-000-0000-000-060	76.02
Total Purchase Order				142.14
719	08/23/2013	ALBRIGHT STEEL & WIRE	412 705 Instructinal Materials	
		ALUMINUM FOR PROJECTS	412-1000-681-317-8800-000-705	600.00
Total Purchase Order				600.00
720	08/23/2013	DATAPORT SYSTEMS, INC	412 705 INSTRUCTINAL MATERIAL	
		CIRCUIT BOARDS FOR ROBOTICS	412-1000-653-317-8800-000-705	300.00
Total Purchase Order				300.00

General Fund 2013-2014
Detail Encumbrance Listing
As of 09/04/2013

PurOrder	Date	To Whom Issued / Detail Description	Po Description / Classification	
721	08/23/2013	GRAINGER	412 705 INSTRUCTIONAL MATERIAL	
		RIVETS AND RIVITER	412-1000-618-317-8800-000-705	100.00
				Total Purchase Order 100.00
722	08/23/2013	LOWES CREDIT SERVICES	412 705 INSTRUCTIONAL TOOLS	
		ELECTRIC SCREW DRIVERS	412-1000-618-317-8800-000-705	240.00
		WOOD FOR PROJECTS	412-1000-681-317-8800-000-705	450.00
				Total Purchase Order 690.00
723	08/23/2013	RADIO SHACK A/R	412 705 INSTRUCTIONAL MATERIAL	
		Model: WM22-0.5 Catalog #: 55057655 MAGNET WIRE	412-1000-681-317-8800-000-705	143.52
				Total Purchase Order 143.52
724	08/23/2013	REGAL PLASTIC SUPPLY CO.	412 705 INSTRUCTIONAL MATERIAL	
		PLASTIC FOR PROJECTS	412-1000-681-317-8800-000-705	400.00
				Total Purchase Order 400.00
725	08/23/2013	WAREHOUSE SUPPLIES	029 135 COPY PAPER	
		ONE PALLET OF WHITE COPY PAPER	029-1000-611-000-0000-000-135	970.00
				Total Purchase Order 970.00
726	08/23/2013	WAREHOUSE SUPPLIES	029 705 PAPER FOR STUDENTS	
		2 PALETS OF PAPER	029-1000-611-100-0000-000-705	2,142.60
				Total Purchase Order 2,142.60
727	08/23/2013	EDUCATION WEEK	051 EDUCATION WEEK SUBSCRIPTIO	
		37 ISSUES OF EDUCATION WEEK DISCOUNT CODE D3H161	000-2321-648-000-0000-000-051	39.00
				Total Purchase Order 39.00
728	08/23/2013	QUILL	023 135 PAPER SHREDDER	
		HSM CLASSIC 80.2 10-12 SHEET STRIP CUT SHREDDER	023-2410-619-000-0000-000-135	149.99
				Total Purchase Order 149.99
729	08/23/2013	OFFICE DEPOT	023-120 OFFICE SUPPLIES	
		LETTER SIZE HANGING FILE FOLDERS	023-2410-619-100-0000-000-120	95.76
				Total Purchase Order 95.76
730	08/23/2013	OFFICE DEPOT	000 051 SUPPLIES	
		116253 SMEAD COLOR FILE FOLDERS, 1/3 CUT, BRIGHTS BOX OF 100	000-2321-619-000-0000-000-051	14.53
		430074 OFFICE DEPOT BRAND CERTIFICATE FRAME PACK OF 3	000-2321-619-000-0000-000-051	11.49
		826876 BIC WITE OUT CORRECTION TAPE, PACK OF 10	000-2321-619-000-0000-000-051	19.99
		520928 OFFICE DEPOT BRAND INVISIBLE TAPE, PACK OF 10	000-2321-619-000-0000-000-051	22.65
		655266 BIC SOFT FEEL RETRACTABLE BALLPOINT PENS, 1.0MM BLACK	000-2321-619-000-0000-000-051	11.45
		330379 SWINGLINE CLASSICUT PRO SERIES TRIMMER, 12"	000-2321-619-000-0000-000-051	47.49
		550657 POST IT SIGN HERE FLAGS	000-2321-619-000-0000-000-051	5.69
		560349 OFFICE DEPOT BRAND MINI BINDER CLIPS	000-2321-619-000-0000-000-051	4.55
				Total Purchase Order 137.84
731	08/23/2013	OKLAHOMA ASBO	051 REGISTRATION	
		ASBO ENC/TREASURER CLASS SEPT. 4TH	000-2511-860-000-0000-000-051	75.00
		DEANNA MOWREY		48
				Total Purchase Order 75.00
732	08/26/2013	RAMAE LYNN COLLINS	023 705 TRAVEL REIMBURSEMENT	

General Fund 2013-2014
Detail Encumbrance Listing
As of 09/04/2013

PurOrder	Date	To Whom Issued / Detail Description	Po Description / Classification	
732	08/26/2013	RAMAE LYNN COLLINS	023 705 TRAVEL REIMBURSEMENT	
		PRINCIPAL TRAVEL REIMBURSEMENT; TO TULSA FOR TULSA MODEL EVAL. TRAINING CONFERENCE AND BACK. AUG. 27 & 28.	023-2213-580-100-0000-000-705	200.00
Total Purchase Order				200.00
733	08/26/2013	HOLIDAY INN EXPRESS - JENKS	023 705 HOTEL/TRAVEL EXPENSE	
		2 NIGHTS, AUG. 27 & 28, HOLIDAY INN EXPRESS/JENKS. FOR TULSA MODEL EVAL. TRAINING. RAMAE COLLINS	023-2213-580-100-0000-000-705	178.00
Total Purchase Order				178.00
734	08/26/2013	WESTCO COMPUTER & LAMINATOR	000 105 LAMINATING FILM	
		LAMINATING FILM FOR CLASSROOM INSTRUCTION	000-1000-619-100-1050-000-105	300.00
Total Purchase Order				300.00
735	08/26/2013	LEARNING ZONEXPRESS	412 705 INSTRUCTIONAL MATERIAL	
		FAT FACTS HANDOUTS	412-1000-681-314-3400-000-705	19.90
		HANDY PORTIONS HANDOUTS	412-1000-681-314-3400-000-705	19.90
		POSTER:50 WAYS TO EAT MORE FRUITS & VEGS FOR BREAKFAST	412-1000-681-314-3400-000-705	14.95
		50 APP ACTIVITIES FOR LIFE SKILLS	412-1000-681-314-3400-000-705	34.95
		5 MINUTES CAREER ACTIVITIES	412-1000-681-314-3400-000-705	29.95
		KITCHEN MATH WORKBOOK	412-1000-681-314-3400-000-705	19.95
		CUSTOMER SERVICE BASICS WITH A SMILE DVD	412-1000-681-314-3400-000-705	79.95
		FOOD SAFETY BULLETIN BOARD KIT	412-1000-681-314-3400-000-705	24.95
		EVERYDAY MATH IN FOODS DVD	412-1000-681-314-3400-000-705	49.95
		50 APP ACTIVITIES FOR FOOD SAFETY & SANITATION	412-1000-681-314-3400-000-705	34.95
		JUST THE FACTS KNIVES DVD	412-1000-681-314-3400-000-705	49.95
		CREATIVE CUTS POSTER	412-1000-681-314-3400-000-705	9.95
		KITCHEN ABBREVIATIONS BINGO	412-1000-681-314-3400-000-705	24.95
Total Purchase Order				414.25
736	08/26/2013	WAL-MART- 6032202040025802	025 705 SCIENCE INSTRUCTION	
		BATTERIES, CUPS, VINEGAR, MATCHES, AND OTHER MISC. LAB SUPPLIES	025-1000-681-100-5000-000-705	500.00
Total Purchase Order				500.00
737	08/26/2013	WAREHOUSE SUPPLIES	029 105 PAPER	
		1602 PALLET-40 CASES DUPLICATING PAPER, 8 1/2X 11 (500 SHEETS PER REAM)	029-1000-611-100-1050-000-105	1,043.60
Total Purchase Order				1,043.60
738	08/26/2013	OFFICE DEPOT	060 3 HOLE PUNCH	
		060 PURCHASE AN ELECTRIC 3 HOLE PUNCH	000-2620-619-000-0000-000-060	166.24
Total Purchase Order				166.24
739	08/26/2013	STAPLES BUSINESS ADVANTAGE 1561215	056 TECHNOLOGY	
		FAX MACHINE - STAPLES PROCESSED A DUPLICATE ORDER, DECIDED TO KEEP 2ND SHIPMENT BECAUSE WE COULD USE THE EXTRA FAX FOR THE DISTRICT.	000-2580-653-000-0000-000-056	259.90
Total Purchase Order				259.90
740	08/26/2013	AIR PRODUCTS SUPPLY CO.	055 REVERSING VALVE F/CENT	
		055 REVERSING VALVE FOR CENTENNIAL ELEMENTARY LIBRARY	000-2620-618-000-0000-000-055	151.77
Total Purchase Order				151.77
741	08/26/2013	WAREHOUSE SUPPLIES	029-120 INSTRUCTIONAL MATERIAL	
		8 1/2 X 11 WHITE COPY PAPER	029-1000-611-100-1050-000-120	1,044.00

General Fund 2013-2014
Detail Encumbrance Listing
As of 09/04/2013

PurOrder	Date	To Whom Issued / Detail Description	Po Description / Classification	
741	08/26/2013	WAREHOUSE SUPPLIES	029-120 INSTRUCTIONAL MATERIAL	
			Total Purchase Order	1,044.00
742	08/27/2013	BARNES & NOBLE	050 DISTRICT NURSEING MANUAL	
		CLINICAL NURSING SKILLS AND TECHNIQUES: 8TH EDITION-USED, PAPERBACK (SEE ATTACHED)	181-2132-641-239-0000-000-050	67.86
			Total Purchase Order	67.86
743	08/27/2013	FEINER SUPPLY	059 CLASSROOM SUPPLIES	
		STICKY BACK TAPE:HOOK 1/2 IN	059-1000-619-239-0000-000-059	27.00
		STICKY BACK TAPE: LOOP 1/2 IN	059-1000-619-239-0000-000-059	27.00
			Total Purchase Order	54.00
744	08/27/2013	WESTERN PSY SERVICES	059 TESTING MATERILAS SPEECH	
		INTERVIEW FORM (PKGS OF 25)	059-2152-614-239-0000-000-059	166.00
		PARENT/CAREGIVER CHECKLIST (PKGS OF 25)	059-2152-614-239-0000-000-059	166.00
			Total Purchase Order	332.00
745	08/27/2013	EASTBAY - DEPT 5374	063 801 CC UNIFORMS	
		-22038 NATHAN RUNNING VEST	063-1000-657-801-0000-000-705	1,049.30
			Total Purchase Order	1,049.30
746	08/27/2013	PENDER'S MUSIC COMPANY	038 135 MUSIC	
		BROADWAY BEAT	038-1000-681-100-0000-000-135	79.99
			Total Purchase Order	79.99
747	08/27/2013	OFFICE DEPOT	125 OFFICE SUPPLIES	
		FILE FOLDERS	000-1000-619-000-0000-000-125	39.96
		RED FILE FOLDERS	000-1000-619-000-0000-000-125	27.98
		3" BINDER	000-1000-619-000-0000-000-125	7.39
		1" BINDER	000-1000-619-000-0000-000-125	6.98
		8 1/2 X 14 COPY PAPER - CASE	000-1000-619-000-0000-000-125	57.99
		APOLLO LASER TRANSPARENCY	000-1000-619-000-0000-000-125	39.99
		REINFORCEMENT LABELS	000-1000-619-000-0000-000-125	8.99
		PAPERMATE MECHANICAL PENCILS	000-1000-619-000-0000-000-125	14.97
		AVERY BIG TAB INSERTABLE PLASTIC DIVIDERS 5-TAB	000-1000-619-000-0000-000-125	11.95
			Total Purchase Order	216.20
748	08/27/2013	GLOBAL EQUIPMENT COMPANY	055 SUPPLIES AND MATERIALS	
		PURCHASE MISC. SUPPLIES AND MATERIALS	000-2620-618-000-0000-000-055	1,000.00
			Total Purchase Order	1,000.00
749	08/27/2013	OKLAHOMA STATE UNIVERSITY	051 REGISTRATION FEES	
		ADVANCED LEVEL 3	000-2511-860-000-0000-000-051	345.00
		SHELLY PAVLIK		
		OCT. 30 & 31		
		ARP 9 & 10		
		PERSONNEL & PAYROLL	000-2511-860-000-0000-000-051	195.00
		NOV. 13-14		
		PERSON TBD		
		TREASURER & ENCUMBRANCE CLERKS	000-2511-860-000-0000-000-051	390.00
		FEB 19-20		50
		SHELLY PAVLIK		
		STACY BROWN		

General Fund 2013-2014
Detail Encumbrance Listing
As of 09/04/2013

PurOrder	Date	To Whom Issued / Detail Description	Po Description / Classification	
749	08/27/2013	OKLAHOMA STATE UNIVERSITY	051 REGISTRATION FEES	
			Total Purchase Order	930.00
750	08/27/2013	ROBIN HOWARD	621 059 SPEECH PATHOLOGIST	
		SPEECH PATHOLOGY SERVICES FOR THE SCHOOL YEAR 2013-2014	621-2152-322-239-0000-000-059	35,000.00
			Total Purchase Order	35,000.00
751	08/27/2013	STAPLES BUSINESS ADVANTAGE 1561215	051 OFFICE SUPPLIES	
		SHARPIE METALLIC FINE POINT MARKERS - SILVER	000-2511-619-000-0000-000-051	17.99
		STAPLES ECONOMY RUBBER BANDS SIZE #16	000-2511-619-000-0000-000-051	7.29
		PAID STAMP	000-2511-619-000-0000-000-051	22.70
		POST-IT SUPER STICKY 25" X 30" EASEL PADS 2/PACK	000-2511-619-000-0000-000-051	65.99
			Total Purchase Order	113.97
752	08/28/2013	LOWES CREDIT SERVICES	053 SUPPLIES/MATERIALS	
		053 PURCHASE SUPPLIES/MATERIALS	000-2620-618-000-0000-000-053	2,000.00
			Total Purchase Order	2,000.00
753	08/28/2013	APPLE INC.	056 TECHNOLOGY	
		I PAD (NEW)	000-2580-653-000-0000-000-056	1,499.97
			Total Purchase Order	1,499.97
754	08/28/2013	MACGILL & CO.	022 140 Nursing Supplies	
		CURAD 1"X3" FLEXIBLE FABRIC BANDAGES 1800/BX LATEX FREE	022-2132-616-100-0000-000-140	97.90
		X-LG FLEXIBLE FABRIC 2"X4" BANDAGES LATEX FREE 50/BX	022-2132-616-100-0000-000-140	18.76
		WOUND WASH SALINE 7.1 OZ CAN	022-2132-616-100-0000-000-140	32.60
		ALCOHOL PREP PADS 200/BX	022-2132-616-100-0000-000-140	5.36
		ISOPROPYL ALCOHOL 16 OZ	022-2132-616-100-0000-000-140	1.59
		COTTON TIPPED APPLICATORS 3" 100 PER BAG	022-2132-616-100-0000-000-140	2.36
		PILL COUNTER WITH SPATULA	022-2132-616-100-0000-000-140	7.84
		PROBE COVERS FOR WELCH ALLYN SURE TEMP THERMOMETER 250/BX	022-2132-616-100-0000-000-140	49.25
		1 OZ GRADUATED MEDICINE CUPS	022-2132-616-100-0000-000-140	1.69
			Total Purchase Order	217.35
755	08/28/2013	MACGILL & CO.	NURSING OFFICE	
		WELCH ALLYN 2.5 V POCKETSCOPE OTOSCOPE W/THROAT ILLUMINATOR LATEX FREE	050-2132-616-100-0000-000-140	188.59
		KLEENSPEC UNIVERSAL SPECULA-LATEX FREE-USED IN CONJUNCTION WITH OTOSCOPE	050-2132-616-100-0000-000-140	3.08
		WELCH ALLYN SURE TEMP 690 PROFESSIONAL THERMOMETER	050-2132-616-100-0000-000-140	251.99
		O2 PULSE OXIMETER	050-2132-616-100-0000-000-140	48.00
		5 PACK SUNDRY CONTAINERS	050-2132-616-100-0000-000-140	24.49
		OMRON DIGITAL FLOOR SCALE	050-2132-616-100-0000-000-140	37.00
		ALCOHOL/LIQUID DISPENSER	050-2132-616-100-0000-000-140	7.98
		3M LITTMAN STETHOSCOPE LATEX FREE	050-2132-616-100-0000-000-140	52.94
		PARAMED SCISSORS	050-2132-616-100-0000-000-140	4.30
		SLANT POINT FORCEPS	050-2132-616-100-0000-000-140	1.70
		NAIL CLIPPERS	050-2132-616-100-0000-000-140	1.40
		FINGER SPLINTS	050-2132-616-100-0000-000-140	19.20
		COBAN LATEX FREE (36)	050-2132-616-100-0000-000-140	64.25
		ACE BANDAGES	050-2132-616-100-0000-000-140	52.40
		ARM SLINGS PEDIATRIC	050-2132-616-100-0000-000-140	18.27
		ALCOHOL PADS	050-2132-616-100-0000-000-140	8.04
		TOOTH HOLDERS	050-2132-616-100-0000-000-140	19.88

General Fund 2013-2014
Detail Encumbrance Listing
As of 09/04/2013

PurOrder	Date	To Whom Issued / Detail Description	Po Description / Classification	
755	08/28/2013	MACGILL & CO.	NURSING OFFICE	
		GAUZE 2"X4.1 12 PER BAG	050-2132-616-100-0000-000-140	5.25
		2X2 GAUZE	050-2132-616-100-0000-000-140	11.85
		4X4 GAUZE	050-2132-616-100-0000-000-140	12.62
		PAPER TAPE	050-2132-616-100-0000-000-140	7.38
		EYEGLOSS REPAIR KIT	050-2132-616-100-0000-000-140	3.78
		SAFETY PINS	050-2132-616-100-0000-000-140	1.74
		KIMBERLY CLARK POWDER FREE NITRILE GLOVES LATEX FREE 250/BX	050-2132-616-100-0000-000-140	79.76
		CURAD SPORTS TRAININER TAPE	050-2132-616-100-0000-000-140	7.39
		PENLIGHT	050-2132-616-100-0000-000-140	9.98
		BLOOD PRESSURE CUFF CHILD	050-2132-616-100-0000-000-140	28.94
		BLOOD PRESSURE CUFF X LG ADULT	050-2132-616-100-0000-000-140	34.49
		GLOW IN THE DARK HANDWASHING KIT	050-2132-616-100-0000-000-140	74.49
		SALINE	050-2132-616-100-0000-000-140	12.62
			Total Purchase Order	1,043.80
756	08/28/2013	BEST BUY BUSINESS ADVANTAGE ACCOUNT	050 SUPPLIES	
		CD DUPLICATOR KANGURU STAND ALONE CD/DVD DUPLICATOR	050-1000-652-100-0001-000-145	199.80
		MODEL: A1DVDS24X		
		SAMSUNG 220W MINI AUDIO SYSTEM MODEL: MX-F630B/ZA	050-1000-652-100-0001-000-145	149.99
		RECHARGEABLE BATTERIES ENERGIZER BATTERIES AA	050-1000-619-100-0001-000-145	34.98
		MODEL: NH15BP-4		
		RECHARGEABLE BATTERY CHARGER	050-1000-618-100-0001-000-145	43.99
		MODEL: CH15MNCP4		
			Total Purchase Order	428.76
757	08/28/2013	MUSIC EXPRESS MAGAZINE	050 MUSIC AMANDA THOMAS	
		2013-2014 BASIC SUBSCRIPTION AMANDA THOMAS TRAILS	050-1000-648-100-3000-000-120	195.00
		2013-2014 BASIC SUBSCRIPTION SCOTT HOWARD VALLEY	050-1000-648-100-3000-000-110	195.00
		2013-2014 BASIC SUBSCRIPTION SOHAILAH STOUT CANYON RIDGE	050-1000-648-100-3000-000-145	195.00
		2013-2014 BASIC SUBSCRIPTION ERIN RAIBER HORIZON	050-1000-648-100-3000-000-140	195.00
			Total Purchase Order	780.00
758	08/28/2013	MACGILL & CO.	050 145 CANYON HEALTH EQUIP	
		BLOOD PRESSURE CUFF KIT	050-2132-616-000-0000-000-145	31.48
		BLOOD PRESSURE CUFF LG ADULT	050-2132-616-000-0000-000-145	27.50
		BLOOD PRESSURE CHILD CUFF	050-2132-616-000-0000-000-145	15.89
		THERMOMETER	050-2132-616-000-0000-000-145	166.95
		THERMOMETER COVERS 200/BOX	050-2132-616-000-0000-000-145	157.50
		NO CONTACT THERMOMETER	050-2132-616-000-0000-000-145	52.95
		OTOSCOPE	050-2132-616-000-0000-000-145	188.59
		PULSE OX	050-2132-616-000-0000-000-145	48.00
		PULSE OX COVER/CASE	050-2132-616-000-0000-000-145	8.95
		5PK SUNDRY CONTAINERS	050-2132-616-000-0000-000-145	24.49
		FINGER SPLINTS 3PK	050-2132-616-000-0000-000-145	19.20
		COBAN LATEX FREE	050-2132-616-000-0000-000-145	60.90
		COBAN BRIGHT/FUN 36 ROLLS	050-2132-616-000-0000-000-145	54.25
		GAUZE 2X2 25/BOX	050-2132-616-000-0000-000-145	5.92
		SILK TAPE 1'X10 YARDS 12/BOX	050-2132-616-000-0000-000-145	32.10
		EYEGLOSS REPAIR KIT	050-2132-616-000-0000-000-145	4.75

PurOrder	Date	To Whom Issued / Detail Description	Po Description / Classification	
758	08/28/2013	MACGILL & CO.	050 145 CANYON HEALTH EQUIP	
		WHEEL CHAIR	050-2132-616-000-0000-000-145	173.19
		DIGITAL SCALE	050-2132-616-000-0000-000-145	37.00
		STETHESCOPE	050-2132-616-000-0000-000-145	24.98
		ELASTIC BANDAGE (ACEWRAP)	050-2132-616-000-0000-000-145	2.40
Total Purchase Order				1,146.99
759	08/28/2013	MACGILL & CO.	022 145 NURSE OFFICE SUP	
		J&J ANTISEPTIC WASH	022-2132-616-000-0000-000-145	34.32
		COTTON BALLS 500/BAG	022-2132-616-000-0000-000-145	6.16
		TWEEZERS	022-2132-616-000-0000-000-145	1.89
		BANDAIDS (1500/BOX)	022-2132-616-000-0000-000-145	63.98
		2X4 BANDAIDS 50/BOX	022-2132-616-000-0000-000-145	34.50
		EAR EASE	022-2132-616-000-0000-000-145	8.05
		MEDICINE CUPS (MEASURED)	022-2132-616-000-0000-000-145	8.45
		BAGGIES FOR ICE PACKS	022-2132-616-000-0000-000-145	19.08
		QTIPS (100PK)	022-2132-616-000-0000-000-145	5.12
		GLOVES--SM	022-2132-616-000-0000-000-145	26.07
		GLOVES MED	022-2132-616-000-0000-000-145	34.76
		GLOVES LRG	022-2132-616-000-0000-000-145	17.38
		PILL CUPS	022-2132-616-000-0000-000-145	11.67
		ALCOHOL PUMP	022-2132-616-000-0000-000-145	7.98
		DENTAL WAX	022-2132-616-000-0000-000-145	3.88
		SALINE 30 CT	022-2132-616-000-0000-000-145	12.62
		COTTON ROLLS/TUBES (2000)	022-2132-616-000-0000-000-145	16.49
Total Purchase Order				312.40
760	08/28/2013	SCHOOL NURSE SUPPLY, INC.	050 145 CANYON HEALTH EQUIP	
		TOOTH HOLDERS	050-2132-616-000-0000-000-145	53.80
Total Purchase Order				53.80
761	08/28/2013	WAL-MART- 6032202040025802	022 145 CANYON HEALTH OFFICE	
		FINGERNAIL CLIPPERS	022-2132-616-000-0000-000-145	3.97
		SEWING KIT/SAFETY PINS 225 ASSORTMENT	022-2132-616-000-0000-000-145	3.27
Total Purchase Order				7.24
762	08/28/2013	QUILL	140 INSTRUCTIONAL SUPPLIES	
		TAPE DISPENSER ITEM# 901-711546QL	000-1000-619-100-1050-000-140	38.30
		STAPLER ITEM# 901-79604Q	000-1000-619-100-1050-000-140	77.87
		STAPLE REMOVER ITEM# 901-793211	000-1000-619-100-1050-000-140	1.89
		TAPE REFILL ITEM# 901-620034	000-1000-619-100-1050-000-140	36.90
		STAPLES ITEM# 901-791123	000-1000-619-100-1050-000-140	7.40
		ADJUSTABLE HAGING FOLDER FRAMES ITEM# 901-98620	000-1000-619-100-1050-000-140	41.58
		HANGING FILE FOLDERS ITEM# 901-7Q5215	000-1000-619-100-1050-000-140	89.85
		ASTROBRIGHT COLORED PAPER ITEM# 901-22224	000-1000-611-100-1050-000-140	37.56
		QUILL STICKY NOTES LINED 4X6 PASTEL ITEM # 901-746F5AQ	000-1000-619-100-1050-000-140	22.38
Total Purchase Order				53
Total Purchase Order				353.73

General Fund 2013-2014
Detail Encumbrance Listing
As of 09/04/2013

PurOrder	Date	To Whom Issued / Detail Description	Po Description / Classification	
763	08/28/2013	SAS SCHOOL DIVISION	510 OFFICE SUPPLIES	
		3000 CHECK IN / OUT PASSES	000-1000-619-100-0000-000-510	375.00
		VISITOR STICKERS ROLL OF 500	000-1000-619-100-0000-000-510	49.50
				Total Purchase Order 424.50
764	08/28/2013	SAM'S CLUB	022 140 NURSING SUPPLIES	
		DIXIE CUPS 3 OZ/600 CUPS	022-2132-616-100-0000-000-140	19.44
		ZIPLOC SANDWICH BAGS 125 CT/4 PK	022-2132-616-100-0000-000-140	17.96
		CLOROX DISINFECTING WIPES 4 PK	022-2132-616-100-0000-000-140	9.36
		KLEENEX 10 BXS 160 CT EACH	022-2132-616-100-0000-000-140	11.48
				Total Purchase Order 58.24
765	08/28/2013	SAM'S CLUB	022 145 CANYON HEALTH OFFICE	
		MINTS 2IB BUCKETS	022-2132-617-000-0000-000-145	20.94
		DIXIE BATH CUPS	022-2132-617-000-0000-000-145	25.92
				Total Purchase Order 46.86
766	08/30/2013	WILSON ELECTRIC CO.	055 MOTOR REPAIRS	
		055 MOTOR REPAIRS	000-2620-438-000-0000-000-055	5,000.00
				Total Purchase Order 5,000.00
767	08/30/2013	CDW GOVERNMENT, INC.	029-120 CLASSROOM INSTRUCTION	
		eReplacements Premium Power POA-LMP142- projector lamp	029-1000-652-100-1050-000-120	252.99
				Total Purchase Order 252.99
768	08/30/2013	CDW GOVERNMENT, INC.	056 TECHNOLOGY	
		GRIFFIN SURVIVOR CASES	000-2580-653-000-0000-000-056	119.97
				Total Purchase Order 119.97
769	08/30/2013	WAREHOUSE TECHNOLOGY	023 705 INK CART/PRINCIPAL	
		HP1012 BLACK LASER JET INK FOR RAMAE COLLINS	023-2410-613-100-0000-000-705	33.06
				Total Purchase Order 33.06
770	08/30/2013	SYNERGY DATA COM	705 SCIENCE INSTRUCTION	
		PROJECTOR MOUNT, UNIVERSAL	000-1000-652-100-5000-000-705	266.64
		PROJECTOR MOUNT, UNIVERSAL	025-1000-652-100-5000-000-705	266.64
				Total Purchase Order 533.28
771	08/30/2013	DIAMOND TROPHIES	110 TEACHER NAME PLATES	
		TEACHER NAME PLATES	000-2410-654-100-0000-000-110	25.20
				Total Purchase Order 25.20
772	08/30/2013	QUILL	705 CLASSROOM SUPPLIES	
		HAMILTON DELUXE STEREO MONO HEADSET	000-1000-652-100-0000-000-705	365.33
				Total Purchase Order 365.33
773	08/30/2013	TUMBLEWEED PRESS, INC.	021 135 SOFTWARE	
		SOFTWARE PURCHASE	021-2220-653-100-0000-000-135	249.00
				Total Purchase Order 249.00
774	08/30/2013	WAL-MART- 6032202040025802	023-120 office supplies	
		Adams 2 part receipt book	023-2410-619-100-0000-000-120	44.95
		4 receipts per page		
		duracell 9V bateries	023-2410-619-100-0000-000-120	20.10
		4 pack		54
				Total Purchase Order 65.05
775	08/30/2013	B&H PHOTO/VIDEO	705 SCIENCE INSTRUCTION	
		PROJECTOR. EPSON. POWERLITE X12	000-1000-652-100-5000-000-705	1,197.00

General Fund 2013-2014
Detail Encumbrance Listing
As of 09/04/2013

PurOrder	Date	To Whom Issued / Detail Description	Po Description / Classification	
775	08/30/2013	B&H PHOTO/VIDEO	705 SCIENCE INSTRUCTION	
		PROJECTOR, EPSON, POWERLITE X12	025-1000-652-100-5000-000-705	1,197.00
		SCREEN, DA-LITE	025-1000-652-100-5000-000-705	226.20
		T-BAR TWIST CLIPS 2/PKG	025-1000-652-100-5000-000-705	55.26
		VGA CABLE, M/M, 50FT, W/AUDIO	025-1000-652-100-5000-000-705	149.94
		POWER ADAPTER, 85W, MAGSAFE	025-1000-652-100-5000-000-705	217.47
			Total Purchase Order	3,042.87
776	08/30/2013	OFFICE DEPOT	510 SPEC ED SUPPLIES	
		VELCRO BRAND DOTS 3/4 BEIGE 200 PK	000-1000-619-100-0000-000-510	67.98
			Total Purchase Order	67.98
777	08/30/2013	OFFICE DEPOT	023 120 office supplies	
		office depot stapler set	023-2410-619-100-0000-000-120	35.96
		office depot pack of 6 clear packing tape	023-2410-619-100-0000-000-120	16.99
		Red Ink "Faxed" Stamp	023-2410-619-100-0000-000-120	7.99
		Red ink "Copy" Stamp	023-2410-619-100-0000-000-120	7.99
		Manilla Envelopbes 6x9	023-2410-619-100-0000-000-120	9.99
		office depot brand box of 100		
			Total Purchase Order	78.92
778	08/30/2013	OFFICE DEPOT	023-120 OFFICE USE	
		HP INK JET PRINTER MODEL 7520 204-163	023-2410-653-100-0000-000-120	149.99
			Total Purchase Order	149.99
779	09/03/2013	AMSAN EVE SUPPLY	057 CUSTODIAL SUPPLIES	
		10 CASES WHITE KITCHEN TOWELS	000-2620-618-000-0000-000-057	275.00
		75 CASES APPEAL TOILET PAPER	000-2620-618-000-0000-000-057	1,845.00
		50 CASES APPEAL PAPER TOWELS	000-2620-618-000-0000-000-057	1,230.00
		50 96 CT TOILET PAPER	000-2620-618-000-0000-000-057	1,747.50
		12 CASES WASP AND HORNET SPRAY	000-2620-618-000-0000-000-057	694.08
		50 CASES 24X33 TRASH BAGS	000-2620-618-000-0000-000-057	1,068.00
		100 CASES 43X48 TRASH BAGS	000-2620-618-000-0000-000-057	2,495.00
		100 CASES 33X60 TRASH BAGS	000-2620-618-000-0000-000-057	3,582.00
		10 CASES CRANBERRY ICE	000-2620-618-000-0000-000-057	539.00
		25 CASES NABC CLEAN AND GO	000-2620-618-000-0000-000-057	1,869.50
		25 CASES DAMP MOP CLEAN AND GO	000-2620-618-000-0000-000-057	535.00
		25 CASE HDQ CLEAN AND GO	000-2620-618-000-0000-000-057	873.00
		25 CASES OF GLASS CLEANER CLEAN AND GO	000-2620-618-000-0000-000-057	1,075.00
		15 CASES RENOWN GLASS CLEANER CANS	000-2620-618-000-0000-000-057	381.60
		15 CASES STERIPHENE II DISENFECTANT	000-2620-618-000-0000-000-057	626.40
		4 ONLY BUDDY JUGS	000-2620-618-000-0000-000-057	87.00
		10 ONLY GRAY MAID CADDIES	000-2620-618-000-0000-000-057	354.70
		50 ONLY SCRAPERS	000-2620-618-000-0000-000-057	124.00
		50 PKGS SINGLE EDGE BLADES 98-1050	000-2620-618-000-0000-000-057	91.50
		36 KITCHEN BROOMS ANGLED	000-2620-618-000-0000-000-057	456.00
			Total Purchase Order	19,949.28
780	09/03/2013	OKLAHOMA JANITORIAL SUPPLY	057 CUSTODIAL SUPPLIES	
		6 ONLY 8Y PRESS COMBO MOP BUCKETTS	000-2620-618-000-0000-000-057	552.00
		12 DOLLIES FOR 44 GAL TRASH CANS	000-2620-618-000-0000-000-057	312.00
		100 BLUE HANDLES TOILET MOPS	000-2620-618-000-0000-000-057	79.00
		100 PLASTIC BOTTLES	000-2620-618-000-0000-000-057	-5,940.00
			000-2620-618-000-0000-000-057	6,000.00
		100 SPRAYERS	000-2620-618-000-0000-000-057	65.00
		12 BOXES SANI SAKS	000-2620-618-000-0000-000-057	234.96

General Fund 2013-2014
Detail Encumbrance Listing
As of 09/04/2013

PurOrder	Date	To Whom Issued / Detail Description	Po Description / Classification	
780	09/03/2013	OKLAHOMA JANITORIAL SUPPLY	057 CUSTODIAL SUPPLIES	
		4 CASES CLASS ROOM TRASH CANS	000-2620-618-000-0000-000-057	422.40
		50 CASES HAND SOAP	000-2620-618-000-0000-000-057	2,365.00
		100 313 PAPER TOWELS	000-2620-618-000-0000-000-057	3,560.00
			Total Purchase Order	7,650.36
781	09/03/2013	LISA J BAILEY	067 TRAVEL	
		MILEAGE FOR 2013-14 TO SITES AND PD	000-2572-580-000-0000-000-067	200.00
			Total Purchase Order	200.00
782	09/03/2013	JANA CARYL CLASON	067 TRAVEL	
		MILEAGE FOR 2013-14 TO SITES AND PD	000-2572-580-000-0000-000-067	200.00
			Total Purchase Order	200.00
783	09/03/2013	CYNTHIA ANN IVY	067 TRAVEL	
		MILEAGE FOR 2013-14 TO SITES AND PD	000-2572-580-000-0000-000-067	200.00
			Total Purchase Order	200.00
784	09/03/2013	PRISCILLA E MAXEY	067 TRAVEL	
		TRAVEL FOR 2013-14 TO SITES AND PD	000-2572-580-000-0000-000-067	200.00
			Total Purchase Order	200.00
785	09/03/2013	CHRISTY LYNN MCKINLEY	067 TRAVEL	
		TRAVEL FOR 2013-14 TO SITES AND PD	000-2572-580-000-0000-000-067	200.00
			Total Purchase Order	200.00
786	09/03/2013	DONNA MARIE ROETKER	067 TRAVEL	
		MILEAGE FOR 2013-14 TO SITES AND PD	000-2572-580-000-0000-000-067	200.00
			Total Purchase Order	200.00
787	09/03/2013	GLENDALE	705 FLAG FOR MEDIA CENTER	
		3 X 5 FRINGED FLAG	000-2220-619-100-0000-000-705	67.50
		SHIPPING AND HANDLING	000-2220-619-100-0000-000-705	10.00
			Total Purchase Order	77.50
788	09/03/2013	MICHAEL NEAL RACHLIN	412 705 MILEAGE REIMB/DECA	
		MILEAGE REIMBURSEMENT FOR DECA	412-1000-580-312-8600-000-705	800.00
			Total Purchase Order	800.00
789	09/03/2013	WAL-MART- 6032202040025802	022 705 SUPPLIES FOR NURSE	
		SUPPLIES FOR NURSES OFFICE : WIPES	022-2132-618-100-0000-000-705	100.00
			Total Purchase Order	100.00
790	09/03/2013	HASTINGS	510 FARRIS EXTENSION SUPPLIES	
		HUNGER GAMES	000-1000-641-100-1110-000-510	199.80
			Total Purchase Order	199.80
791	09/03/2013	UNITED PRINTING	510 SELF INKING STAMPS	
		DATE RECEIVED SELF INKING STAMP	000-2410-619-100-0000-000-510	29.00
		CHERYL RODGERS SIGNATURE STAMP	000-2410-619-100-0000-000-510	29.00
		CHRISTY BRADLEY SIGNATURE STAMP	000-2410-619-100-0000-000-510	29.00
		DANNY BROWN SIGNATURE STAMP	000-2410-619-100-0000-000-510	29.00
		RYAN MCKINNEY SIGNATURE STAMP	000-2410-619-100-0000-000-510	29.00
			Total Purchase Order	145.00
792	09/03/2013	WAL-MART- 6032202040025802	510 OLIGANGA EXT. SUPPLIES	56
		ONE 3D PUZZLE	000-1000-681-100-0000-000-510	20.00
		JIGSAW PUZZLES	000-1000-681-100-0000-000-510	30.00
		2 RIIRIK CIRCLES	000-1000-681-100-0000-000-510	24.00

General Fund 2013-2014
Detail Encumbrance Listing
As of 09/04/2013

PurOrder	Date	To Whom Issued / Detail Description	Po Description / Classification	
792	09/03/2013	WAL-MART- 6032202040025802	510 OLIGANGA EXT. SUPPLIES	
		PUZZLE/ACTIVITY BOOK	000-1000-681-100-0000-000-510	25.00
			Total Purchase Order	99.00
793	09/03/2013	WAL-MART- 6032202040025802	510 OTTO EXTENTION SUPPLIES	
		boye aluminum crochet hook bonus set.5.22	000-1000-681-100-0000-000-510	15.66
			Total Purchase Order	15.66
794	09/03/2013	TUMBLEWEED PRESS, INC.	021 125 TumbleBook Subscriptio	
		Subscription to TumbleBook Library	021-2220-641-100-1050-000-125	249.00
			Total Purchase Order	249.00
795	09/03/2013	SAM'S CLUB	510 APPLE REMOTE BATTERIES	
		ENERGIZER LITHIUM BATTERY 2032 - 6PACK	000-1000-619-100-0000-000-510	44.90
			Total Purchase Order	44.90
796	09/03/2013	OFFICE DEPOT	412 510 CLASSROOM SUPPLIES	
		HIGH YIELD BLACK	412-1000-613-312-8600-000-705	71.97
		HIGH YIELD CYAN	412-1000-613-312-8600-000-705	59.97
		HIGH YIELD, MAGENTA	412-1000-613-312-8600-000-705	59.97
		HIGH YIELD YELLOW	412-1000-613-312-8600-000-705	59.97
		HIGH YIELD PHOTO	412-1000-613-312-8600-000-705	59.97
		BLACK TONER CARTRIDGE DELL, HIGHYIELD	412-1000-613-312-8600-000-705	101.99
			Total Purchase Order	413.84
797	09/03/2013	SOONER PREVENTION SERVICES, LLC	050 705 PARKING LOT SECURITY	
		PARKING LOT SECURITY FOR THE 2013-2014 SCHOOL YEAR	050-2660-344-000-0000-000-705	560.00
			050-2660-344-000-0000-000-705	9,440.00
			Total Purchase Order	10,000.00
799	09/04/2013	TIMBERLAKE CONSTRUCTION	055 A/C UNIT IN HS PRESSBOX	
		055 REPAIR THE A/C UNIT THAT IS IN THE HS PRESSBOX	000-2620-433-000-0000-000-055	400.00
			Total Purchase Order	400.00
800	09/04/2013	ASSOCIATED APPLIANCE, INC.	055 PARTS/SUPPLIES	
		PURCHASE PARTS AND SUPPLIES FOR VARIOUS APPLIANCES	000-2620-618-000-0000-000-055	500.00
			Total Purchase Order	500.00
801	09/04/2013	APPLE INC.	572 050 ELL IPADS	
		IPADS	572-1000-653-410-1310-000-110	998.00
		ENGRAVING: TITLE III: ELL MUSTANG PS 2013-14		
			Total Purchase Order	998.00
802	09/04/2013	CDW GOVERNMENT, INC.	572 110 ELL IPAD CASES	
		GRIFFIN SURVIVOR	572-1000-653-410-1310-000-110	80.00
			Total Purchase Order	80.00
803	09/04/2013	DELL COMPUTER CORP	023-120 OFFICE SUPPLIES	
		DELL COLOR PRINTER 01760nw	023-2410-611-100-0000-000-120	224.99
			Total Purchase Order	224.99
804	09/04/2013	A.S.C. AUTOMOTIVE	054 VEH PARTS	
		054 VEH PARTS	000-2650-612-000-0000-000-054	10,000.00

General Fund 2013-2014
Detail Encumbrance Listing
As of 09/04/2013

PurOrder	Date	To Whom Issued / Detail Description	Po Description / Classification	
804	09/04/2013	A.S.C. AUTOMOTIVE	054 VEH PARTS	
			Total Purchase Order	10,000.00
805	09/04/2013	CARDINAL WINDSHIELD REPAIR	054 WINDSHIELD REPAIR	
054	WINDSHIELD REPAIR		000-2740-612-000-0000-000-054	500.00
			Total Purchase Order	500.00
806	09/04/2013	MICHAEL J. LOVELACE	054 TRANSMISSION REPAIR	
054	TRANSMISSION REPAIR		000-2740-439-000-0000-000-054	2,500.00
			Total Purchase Order	2,500.00
807	09/04/2013	WAL-MART- 6032202040025802	054 PURCHASE SUPPLIES	
60	HARDBOARD MEMO @\$1.27 EACH		000-2720-619-000-0000-000-054	1,100.00
60	MAGLITE FLASH LIGHTS @\$10.00 EACH			
5	WIREBOUND MESSAGE BOOKS @\$6.62 EACH			
6	JUMBO PAPER CLIPS @\$7.27 EACH			
6	SHEET PROTECTORS 50 COUNT @\$3.67 EACH			
1	COLORED PAPER @\$15.81 EACH			
60	INDEX CARDS @.97 EACH			
10	INK PENS 10 PK @ \$.97 EACH			
1	TRANSPARENT TAPE @12.77			
15	BROOMS@\$7.99 EACH			
15	TRASH CANS @\$7.99 EACH			
			Total Purchase Order	1,100.00
808	09/04/2013	ALL SEASON BUILDING & SUPPLY	012 705 BUILDING SUPPLIES	
3/4"	PLYWOOD SHEETS (4X8)		012-1000-618-100-4022-000-705	72.00
1X4X10	PINE		012-1000-618-100-4022-000-705	44.00
2X4X8	PINE		012-1000-618-100-4022-000-705	28.00
1.5"	SCREWS (500)		012-1000-618-100-4022-000-705	40.00
GALLON	OF WOOD GLUE		012-1000-618-100-4022-000-705	15.00
KITCHEN	HANDLES		012-1000-618-100-4022-000-705	80.00
			Total Purchase Order	279.00
809	09/04/2013	EDUCATIONAL THEATRE ASSOCIATION	012 705 ANNUAL MEMBERSHIP DUES	
ANNUAL	MEMBERSHIP DUES		012-1000-810-100-4022-000-705	75.00
			Total Purchase Order	75.00
810	09/04/2013	NATIONAL FORENSIC LEAGUE	012 705 ANNUAL MEMBERSHIP DUES	
ANNUAL	MEMBERSHIP DUES		012-1000-810-100-4022-000-705	99.00
			Total Purchase Order	99.00
811	09/04/2013	AMERICAN BAND ACCESSORIES INC	007 705 GUARD POLES AND SILK	
GOLD	POLE 6' WITH RUBBER WHITE END CAPS		007-1000-681-901-0000-000-705	341.00
SILVER	POLE 6' WHITE RUBBER END CAP		007-1000-681-901-0000-000-705	341.00
PRACTICE	FLAG SILK F-7 DEWBERRY		007-1000-681-901-0000-000-705	339.45
			Total Purchase Order	1,021.45
812	09/04/2013	VICTORIA MARIE BAILEY	189 705 HMB MILEAGE/ J.V.	
HOMEBOUND	MILEAGE FOR J.V. 8/27/13-12/20/13		189-1000-580-422-0000-000-705	284.76
			Total Purchase Order	284.76
813	09/04/2013	KRISTEN KAROL COX	189 705 HMB MILEAGE/ B.A.	
HOMEBOUND	MILEAGE FOR B.A. 8/26/13-12/20/13		189-1000-580-422-0000-000-705	244.08
			Total Purchase Order	244.08
814	09/04/2013	VANESSA LYNN MCINTIRE	189 705 HMB MILEAGE / S.M.	58
HOMEBOUND	MILEAGE FOR S.M. 8/27/13-12/20/13		189-1000-580-422-0000-000-705	189.84
			Total Purchase Order	189.84

General Fund 2013-2014
Detail Encumbrance Listing
As of 09/04/2013

PurOrder	Date	To Whom Issued / Detail Description	Po Description / Classification	
815	09/04/2013	BILINGUAL DICTIONARIES	572 505/510 BIL DICTIONARIES	
603X		SPANISH WORD TO WORD W CONTENT VOC	572-1000-681-410-1310-000-510	49.90
600X		SPANISH WORD TO WORD	572-1000-681-410-1310-000-510	29.90
798X		VIETNAMESE WORD TO WORD W CONTENT	572-1000-681-410-1310-000-510	24.95
Total Purchase Order				104.75
816	09/04/2013	SCHOOL SPECIALTY	572 140 ANITA CONWAY	
9-082079-222		WORLD MAP	572-1000-681-410-1310-000-140	19.97
		SHIPPING AND HANDLING	572-1000-681-410-1310-000-140	3.00
Total Purchase Order				22.97
817	09/04/2013	DYNAMIC MEASUREMENT GROUP	541 125 DIBELS PD	
		DIBELS TRAINING FOR RAYLENE RHYNES AT CREEK	541-2213-860-000-0000-000-125	570.00
		SEPT. 10-11, OKC \$250		
		OCT. 8, OKC \$160		
		NOV. 12, OKC \$160		
Total Purchase Order				570.00
818	09/04/2013	LAKESHORE LEARNING	572 140 ANITA CONWAY	
AW - 447		WORLD MAP	572-1000-681-410-1310-000-140	49.99
		SHIPPING AND HANDLING	572-1000-681-410-1310-000-140	7.50
Total Purchase Order				57.49
819	09/04/2013	FLINN SCIENTIFIC, INC.	025 705 SCIENCE INSTRUCTION	
		HEXANE, 100ML	025-1000-681-100-5000-000-705	6.95
		PULSE GLASS	025-1000-681-100-5000-000-705	14.95
		DENSITY CUBE SET	025-1000-681-100-5000-000-705	47.90
		HALL'S CARRIAGE	025-1000-681-100-5000-000-705	116.50
		TRIPLE TANDEM PULLEY	025-1000-681-100-5000-000-705	47.40
		LENS SUPPORT, SMALL	025-1000-681-100-5000-000-705	11.70
		MIRROR SUPPORT, LARGE	025-1000-681-100-5000-000-705	14.40
		INDEX OF REFRACTION PLATE	025-1000-681-100-5000-000-705	63.00
		PITH BALLS & THREADS	025-1000-681-100-5000-000-705	4.55
		BIMETAL STRIP	025-1000-681-100-5000-000-705	6.90
		BALL & RING APPARATUS	025-1000-681-100-5000-000-705	14.50
		38 MM DOUBLE CONVEX LENS	025-1000-681-100-5000-000-705	18.60
		38 MM DOUBLE CONCAVE LENS	025-1000-681-100-5000-000-705	19.50
		CONCAVE/CONVEX MIRROR	025-1000-681-100-5000-000-705	42.30
		FLAT MIRROR	025-1000-681-100-5000-000-705	25.20
		TUNING FORK, C-512	025-1000-681-100-5000-000-705	73.20
		TUNING FORK, A	025-1000-681-100-5000-000-705	73.20
		RUBBER Mallet	025-1000-681-100-5000-000-705	52.50
		RUBBER FRICTION ROD	025-1000-681-100-5000-000-705	34.80
		FAMILIES OF ELEMENTS LAB	025-1000-681-100-5000-000-705	97.40
		CHEMICAL REACTIONS KIT	025-1000-681-100-5000-000-705	114.30
		CHEMICAL FORMULAS KIT	025-1000-681-100-5000-000-705	97.00
		WOODEN SPLINTS	025-1000-681-100-5000-000-705	5.80
		INERTIA DEVICE	025-1000-681-100-5000-000-705	17.00
		NEWTONIAN DEMONSTRATION	025-1000-681-100-5000-000-705	30.50
		2ND LAW OF MOTION APPARATUS	025-1000-681-100-5000-000-705	37.55
		TABLETOP PULLEYS	025-1000-681-100-5000-000-705	46.60
		HYDRION SPECTRAL TEST PAPER, 1-14 PH	025-1000-681-100-5000-000-705	35.70
		SUDAN III	025-1000-681-100-5000-000-705	57.90
		BIURET	025-1000-681-100-5000-000-705	20.95
		POLYMERGEL SLIME KIT	025-1000-681-100-5000-000-705	57.90
Total Purchase Order				1,266.65

General Fund 2013-2014
Detail Encumbrance Listing
As of 09/04/2013

PurOrder	Date	To Whom Issued / Detail Description	Po Description / Classification	
820	09/04/2013	WARD'S SCIENCE	025 705 SCIENCE INSTRUCTION	
		STEEL BALLS 19MM	025-1000-681-100-5000-000-705	16.00
		STEEL BALLS 25MM	025-1000-681-100-5000-000-705	32.50
		PULLEY CORD	025-1000-681-100-5000-000-705	4.85
		STOP WATCHES	025-1000-681-100-5000-000-705	49.50
		LIGHT SOURCE/BATTERY HOLDER	025-1000-681-100-5000-000-705	66.00
		CALIPER	025-1000-681-100-5000-000-705	8.50
		PLASTIC FRICTION ROD	025-1000-681-100-5000-000-705	3.90
		GRANITE DISPLAY	025-1000-681-100-5000-000-705	10.25
		SLIME PREP KIT	025-1000-681-100-5000-000-705	30.40
			Total Purchase Order	221.90
821	09/04/2013	WARDS	025 705 SCIENCE INSTRUCTION	
		SQUID PAIL OF 50	025-1000-681-100-5000-000-705	224.30
		CRAYFISH PAIL OF 100	025-1000-681-100-5000-000-705	96.85
		DOGFISH SHARKS	025-1000-681-100-5000-000-705	647.55
			Total Purchase Order	968.70
822	09/04/2013	HOMELAND	412 705 Groceries	
		Groceries for foods labs	412-1000-681-314-8400-000-705	750.00
			Total Purchase Order	750.00
823	09/04/2013	LAKESHORE LEARNING	050-120 NEW KINDER CLASS	
		NEW KINDERGARTEN MATERIALS	050-1000-681-100-1050-000-120	2,298.32
		SHIPPING AND HANDLING	050-1000-681-100-1050-000-120	300.00
			Total Purchase Order	2,598.32
824	09/04/2013	MACGILL & CO.	022 140 first aid supplies	
		BANDAGES 1X3 900	022-2132-616-100-0000-000-140	25.00
		KIMBERLY CLARK NITRILE LATEX FREE GLOVES MD 250/BX	022-2132-616-100-0000-000-140	19.94
		ALCOHOL PREP PADS 200 BX	022-2132-616-100-0000-000-140	5.36
		NICE CLEAN TOWELETTES 100 PER BX	022-2132-616-100-0000-000-140	5.98
			Total Purchase Order	56.28
825	09/04/2013	OFFICE WORLD, INC	067 OFFICE SUPPLIES	
		CLASSIFICATION FOLDERS LEGAL 10 PER BOX	000-2572-619-000-0000-000-067	491.90
		File Folders, 1/3 Cut Top Tab, Letter, Manila, 100 / Box	000-2572-619-000-0000-000-067	59.60
		Hanging File Folders, Compressed Paper Fiber, 18 x 14, Green, 25 / Box	000-2572-619-000-0000-000-067	273.57
		Stor / File Storage Box, Legal, Locking Lid, White / Blue, 12 / Carton	000-2572-619-000-0000-000-067	81.28
		59Cb Light-Duty Cross-Cut Shredder, 9 Sheet Capacity	000-2572-619-000-0000-000-067	99.89
		Pop-Up Note Refills, 3 x 3, Five Pastel Colors, 12 100-Sheet Pads / Pack	000-2572-619-000-0000-000-067	29.78
			Total Purchase Order	1,036.02
826	09/04/2013	PCI EDUCATIONAL PUBLICATIONS	456 705 VOC REHAB	
		SELF DETERMINE READERS	456-1000-681-239-2765-000-705	199.95
		CAREERS IN COMMUNITY 1	456-1000-681-239-2765-000-705	71.95
		CAREERS IN COMMUNITY 2	456-1000-681-239-2765-000-705	71.95
		FUNCTIONAL MONEY - MONEY EQUIV.	456-1000-681-239-2765-000-705	79.95
		FUNC. MONEY COINS & DOLLARS	456-1000-681-239-2765-000-705	79.95
			Total Purchase Order	503.75
827	09/04/2013	WAL-MART- 6032202040025802	456 705 SUPPLIES FOR VOC REHAB	60
		COFFEE CART SUPPLIES	456-1000-681-239-2765-000-705	200.00
		OJT OFFICE SUPPLIES	456-1000-619-239-2765-000-705	100.00

General Fund 2013-2014
Detail Encumbrance Listing
As of 09/04/2013

PurOrder	Date	To Whom Issued / Detail Description	Po Description / Classification	
827	09/04/2013	WAL-MART- 6032202040025802	456 705 SUPPLIES FOR VOC REHAB	
			Total Purchase Order	300.00
828	09/04/2013	REGAL PLASTIC SUPPLY CO.	412 705 INSTRUCTIONAL MATERIAL	
		PLASTIC FOR PROJECTS	412-1000-681-317-8800-000-705	400.00
			Total Purchase Order	400.00
829	09/04/2013	STERICYCLE	057 CUSTODIAL SUPPLIES	
		2 ONLY R6145 HAZARD STEP ON TRASH CAN	000-2620-618-000-0000-000-057	398.00
			Total Purchase Order	398.00
830	09/04/2013	TUMBLEWEED PRESS, INC.	021 110 TUMBLEBOOKS	
		SUBSCRIPTION TO TUMBLEBOOK LIBRARY-RENEWAL 4-15-14 TO 4-15-15	021-2220-810-100-0000-000-110	249.00
			Total Purchase Order	249.00
831	09/04/2013	AMAZON.COM-604578781005224	412 705 remotes for projectors	
		2- Mitsubishi DLP Projector remotes EX24OU \$30 each plus shipping	412-1000-652-311-8000-000-705	80.00
			Total Purchase Order	80.00
832	09/04/2013	OFFICE DEPOT	572 ELL SUPPLIES	
		810838 - MANILLA FILE FOLDERS - CALAH LYNES	572-1000-619-410-1310-000-110	6.64
		810838 - MANILLA FILE FOLDER - LINDA KOLAR	572-1000-619-410-1310-000-120	6.64
		810838 - MANILLA FILE FOLDER - STACY MATTINGLY	572-1000-619-410-1310-000-115	6.64
		810838 - MANILLA FILE FOLDERS - TAMMI HAAS	572-1000-619-410-1310-000-125	6.64
		305466 - LEGAL NOTE PADS - DOZEN	572-1000-619-410-1310-000-510	7.13
			Total Purchase Order	33.69
833	09/04/2013	OFFICE DEPOT	067 OFFICE SUPPLIES	
		DYMO LabelWriterr 450 Turbo Labeler	000-2572-619-000-0000-000-067	129.99
		INK PEN	000-2572-619-000-0000-000-067	7.40
		DYMO LABELS	000-2572-619-000-0000-000-067	69.12
			Total Purchase Order	206.51
834	09/04/2013	OFFICE DEPOT	067 OFFICE SUPPLIES	
		File Sorter	000-2572-619-000-0000-000-067	20.99
		Office Depotr Brand 99% Recycled Incline Sorter, 5 Compartments, Black		
		Ink Pen	000-2572-619-000-0000-000-067	7.40
		Pilotr Dr. GripT Center Of Gravity Ballpoint Pen, 1.0 mm, Medium Point, Gray Metallic Barrel, Black Ink		
		Ink Pens	000-2572-619-000-0000-000-067	14.80

General Fund 2013-2014
Detail Encumbrance Listing
As of 09/04/2013

PurOrder	Date	To Whom Issued / Detail Description	Po Description / Classification
834	09/04/2013	OFFICE DEPOT	067 OFFICE SUPPLIES

Pilotr Dr. GripT Retractable Ballpoint Pen, 1.0 mm, Medium Point, Black Barrel, Black Ink	000-2572-619-000-0000-000-067	44.99
Business card paper		

Office Depotr Brand Matte Business Cards, 2" x 3 1/2", White, Pack Of 1,000	000-2572-619-000-0000-000-067	46.08
Dymo label		

DYMO LabelWriterr 30251 White Address Labels, 3.5" x 1.13", Pack Of 2 Rolls (260 Labels)	000-2572-619-000-0000-000-067	5.36
Scotch 100% Recycled Desk Tape Dispenser, Black		
Total Purchase Order		139.62

835 09/04/2013	OFFICE DEPOT	023-120 office supploes
Binder Clips Med box of 24		023-2410-619-100-0000-000-120 7.58
office depot brand small binder clips box of 36		023-2410-619-100-0000-000-120 5.98
LG Binder Clips box of 12		023-2410-619-100-0000-000-120 7.58
post it notes 3x3 12 pack		023-2410-619-100-0000-000-120 29.98
Total Purchase Order		51.12

836 09/04/2013	STAPLES BUSINESS ADVANTAGE 1561215	059 OT/PT SUPPLIES
STAPLES HANGING FILE FOLDERS, STANDARD GREEN, LEAGL SIZE HOLDS 8 1/2 X 14, 25 BOX		059-2135-619-239-0000-000-135 14.50
CENTENNIAL OT/PT		
STAPLES HANGING FILE FOLDERS, STANDARD GREEN, LETTER SIZE HOLDS 8 1/2 X 11, 25/BOX		059-2135-619-239-0000-000-135 11.42
CENTENNIAL OT/PT		62
STAPLES COLORED TOP-TAB FILE FOLDERS, 1/3 CUT, GRAY, LETTER-SIZE HOLDS 8 1/2 X 11, 100/BOX		059-2135-619-239-0000-000-135 10.39
STAPLES COLORED TOP-TAB FILE FOLDERS, 1/3 CUT,		059-2135-619-239-0000-000-135 11.31

General Fund 2013-2014
Detail Encumbrance Listing
As of 09/04/2013

PurOrder	Date	To Whom Issued / Detail Description	Po Description / Classification	
836	09/04/2013	STAPLES BUSINESS ADVANTAGE 1561215	059 OT/PT SUPPLIES	
		PURPLE, LETTER SIZE HOLDS 8 1/2 X 11, 100/BOX		
		STAPLES POLY PROJECT JACKETS, LETTER, ASSORTED	059-1000-619-239-0000-000-705	10.58
		TRANSPARENT, 5/PACK		
		ONE TO CANYON RIDGE		
		ONE TO HIGH SCHOOL/TRACI REIMER		
			Total Purchase Order	58.20
837	09/04/2013	STAPLES BUSINESS ADVANTAGE 1561215	412 705 Ink Toner	
		Need two (2) Black Ink Toner cartridges for Career Tech Class	412-1000-653-316-8100-000-705	330.00
		Color printer - Item # 620325 Model # Q7560A @ \$165 each for a		
		total of \$330 for school year 2013-2014 printer is HP Color		
		LaserJet 3000dn		
			Total Purchase Order	330.00
838	09/04/2013	STAPLES BUSINESS ADVANTAGE 1561215	412 705 Ink Toner	
		Need two (2) HP 126A Black Toner cartridge (CE310A) for class	412-1000-611-316-8100-000-705	110.00
		printr. Item # 905412 @ \$55.00 each - for a total of \$110.00 for		
		school year 2013-2014		
		Need two (2) Hp 126A Cyan/Magenta?Yellow laserjet Toner	412-1000-611-316-8100-000-705	350.00
		cartridges (CF341A) item # 475902 for class printer @ 175 each -		
		for school year 2013-2014 for a total of \$350		
			Total Purchase Order	460.00
839	09/04/2013	MUSTANG COLLISION CENTER, INC.	050 REPAIR TO '09 EXPLORER	
		REPAIR TO '09 EXPLORER, DOL: 8/27/13, CLAIM#	050-2720-521-000-0000-000-050	1,000.00
		P625-13-92038-01	050-5600-930-000-0000-000-051	1,047.95
			Total Purchase Order	2,047.95
			Total Fund	763,975.14

MUSTANG PUBLIC SCHOOLS
Encumbrance Register
General Fund 2013-2014

<i>fYear</i>	<i>Fund</i>	<i>P.O.</i>	<i>Vendor Name</i>	<i>Description</i>	<i>eDate</i>	<i>Classified</i>
2014	11	50377	ERIC JASON HARRINGTON	PAYROLL	08/16/2013	1,588.74
2014	11	50378	MICHAEL ALLEN CARTWRIGHT	PAYROLL	08/16/2013	2,522.39
2014	11	50379	JOSEPH ANTHONY MURRAY JR	PAYROLL	08/16/2013	1,852.07
2014	11	50380	JUDITH MARIE KYLE	PAYROLL	08/16/2013	1,717.10
2014	11	50381	MICHAEL RYAN PRICE	PAYROLL	08/16/2013	1,588.74
2014	11	50382	NATHAN TYLER BRITT	PAYROLL	08/16/2013	1,588.74
2014	11	50383	NANCY MARCELA PLATERO	PAYROLL	08/16/2013	2,215.11
2014	11	50384	TAMARA KAY SOLANO	PAYROLL	08/16/2013	1,588.74
2014	11	50385	CHERYL L SNOWDEN	PAYROLL	08/16/2013	169.17
2014	11	50386	JESSICA MARIE CREACH	PAYROLL	08/16/2013	145.01
2014	11	50387	ALLEGRA LIVIA BARKER	PAYROLL	08/16/2013	35.85
2014	11	50388	KRYSTAL GWEN WILLIAMS	PAYROLL	08/16/2013	145.01
2014	11	50389	PAULA SUE VOLENSTINE	PAYROLL	08/16/2013	169.17
2014	11	50390	THOMAS EDWARD WOLFE	PAYROLL	08/16/2013	169.17
2014	11	50391	DONNA ANN GOLEMON	PAYROLL	08/16/2013	65.24
2014	11	50392	CRAIG R ALLEN	PAYROLL	08/16/2013	108.75
2014	11	50393	GRETA YVETTE BENSCH	PAYROLL	08/16/2013	79.75
2014	11	50394	AMY LYNN REED	PAYROLL	08/16/2013	79.75
2014	11	50395	LAUREN ASHLEY TILLEY	PAYROLL	08/16/2013	169.17
2014	11	50396	TERESA ANN CHRISTENSEN	PAYROLL	08/16/2013	181.26
2014	11	50397	ANGELA JENNIFER HINDS	PAYROLL	08/16/2013	322.95
2014	11	50398	JESSICA DENISE WARCUP	PAYROLL	08/16/2013	169.17
2014	11	50399	KYLE ARDEN GUYER	PAYROLL	08/16/2013	1,002.89
2014	11	50400	CHRISTOPHER NATHAN LOCKE	PAYROLL	08/16/2013	96.66
2014	11	50401	GREGORY SCOTT OSBORNE	PAYROLL	08/16/2013	181.26
2014	11	50402	LINDA RENEE THIEMANN	PAYROLL	08/16/2013	235.61
2014	11	50403	RHODA CAROTHERS	PAYROLL	08/16/2013	145.01
2014	11	50404	SHERRY BRAY	PAYROLL	08/16/2013	100.49
2014	11	50405	SHAROLYN DAVIS	PAYROLL	08/16/2013	169.17
2014	11	50406	LOUIS A EDMONDS II	PAYROLL	08/16/2013	169.17
2014	11	50407	KATHY M BLACKWELL	PAYROLL	08/20/2013	7,264.83
2014	11	50408	K RENEE BOATMAN	PAYROLL	08/20/2013	7,178.40
2014	11	50409	DANIEL G BROWN	PAYROLL	08/20/2013	6,432.63
2014	11	50410	SHAWNA K CARTER	PAYROLL	08/20/2013	7,007.31
2014	11	50411	CRAIG E CHESTNUT	PAYROLL	08/20/2013	7,192.67
2014	11	50412	HAROLD H DUNN	PAYROLL	08/20/2013	5,319.43
2014	11	50413	TAMARA MICHELLE SCHRICK	PAYROLL	08/20/2013	6,621.17
2014	11	50414	JENNIFER L YOUNG	PAYROLL	08/20/2013	5,654.72
2014	11	50415	LAQUITA D SEMMLER	PAYROLL	08/20/2013	7,029.87
2014	11	50416	CHAD ANDREW COLLIER	PAYROLL	08/20/2013	5,915.60
2014	11	50417	RYAN SAMUEL WAGGONER	PAYROLL	08/20/2013	6,167.48
2014	11	50418	HOLLY CHRISTINE MCKINNEY	PAYROLL	08/20/2013	7,372.26
2014	11	50419	MICHAEL ELLIOTT OSSENKOP	PAYROLL	08/20/2013	8,131.65
2014	11	50420	MELISSA DAWN MALLOY	PAYROLL	08/20/2013	5,532.91
2014	11	50421	RYAN T MCKINNEY	PAYROLL	08/20/2013	7,272.58
2014	11	50422	ROBERT D FOREMAN	PAYROLL	08/20/2013	6,539.87
2014	11	50423	MOLLY DEE WILSON	PAYROLL	08/20/2013	6,704.45
2014	11	50424	JANDRA KAY HONEMAN	PAYROLL	08/20/2013	5,108.26
2014	11	50425	SHAYNA DENISE AUSTIN	PAYROLL	08/20/2013	6,510.56
2014	11	50426	ALISHA NOEL SUFFIELD	PAYROLL	08/20/2013	5,990.03
2014	11	50427	CHRISTOPHER AARON TOBLER	PAYROLL	08/20/2013	6,841.11
2014	11	50428	SUSAN ELIZABETH DOMBEK	PAYROLL	08/20/2013	6,341.01
2014	11	50429	RAMAE LYNN COLLINS	PAYROLL	08/20/2013	6,869.51
2014	11	50430	CHRISTY A BRADLEY	PAYROLL	08/20/2013	6,551.02
2014	11	50431	JILLIAN A MITCHELL	PAYROLL	08/20/2013	6,474.92
2014	11	50432	TAMARA RAE ROGERS	PAYROLL	08/20/2013	5,611.31

MUSTANG PUBLIC SCHOOLS
Encumbrance Register
General Fund 2013-2014

<i>fYear</i>	<i>Fund</i>	<i>P.O.</i>	<i>Vendor Name</i>	<i>Description</i>	<i>eDate</i>	<i>Classified</i>
2014	11	50435	SHARYL GENE ALLEN	PAYROLL	08/28/2013	1,641.66
2014	11	50436	RANDY B CARDENAS	PAYROLL	08/28/2013	2,314.48
2014	11	50437	DIANE M CERNY	PAYROLL	08/28/2013	5,382.50
2014	11	50438	SHERRI L DAVIS	PAYROLL	08/28/2013	4,898.08
2014	11	50439	PAMELA BYERS GEORGE	PAYROLL	08/28/2013	5,382.50
2014	11	50440	PAMELA J GREENWELL	PAYROLL	08/28/2013	5,382.50
2014	11	50441	JOYCE EYLEEN HESS	PAYROLL	08/28/2013	1,551.32
2014	11	50442	JEN L NELSON	PAYROLL	08/28/2013	4,494.39
2014	11	50443	LU DORA OVERMON	PAYROLL	08/28/2013	2,879.64
2014	11	50444	CAROLYN J QUINTERO	PAYROLL	08/28/2013	1,383.30
2014	11	50445	STEPHANIE A RANKIN	PAYROLL	08/28/2013	3,148.76
2014	11	50446	HEATH SAMUEL BUSH	PAYROLL	08/28/2013	1,103.41
2014	11	50447	PATRICIA JAYNE STURDY	PAYROLL	08/28/2013	3,579.36
2014	11	50448	PATRICIA LYNN HEATH	PAYROLL	08/28/2013	1,372.54
2014	11	50449	LEIGH KASHEA ARMSTRONG	PAYROLL	08/28/2013	726.64
2014	11	50450	MANDY JILL SCOTT	PAYROLL	08/28/2013	457.51
2014	11	50451	DAVID EARL WESTON	PAYROLL	08/28/2013	3,175.68
2014	11	50452	JACI LYNN WOLF	PAYROLL	08/28/2013	1,345.63
2014	11	50453	KIMBERLY HINES	PAYROLL	08/28/2013	2,933.46
2014	11	50454	TAMMY LYNETTE DAVIS	PAYROLL	08/28/2013	1,862.35
2014	11	50455	CARRIE ELAINE SHOCKLEY	PAYROLL	08/28/2013	1,014.92
2014	11	50456	DANIEL KEITH ALLEN	PAYROLL	08/28/2013	2,798.90
2014	11	50457	RYNDA LAYN CURL	PAYROLL	08/28/2013	457.51
2014	11	50458	MEGAN BREANNE BRODERICK	PAYROLL	08/28/2013	592.08
2014	11	50459	ASHLYN VICTORIA BOSWELL	PAYROLL	08/28/2013	430.60
2014	11	50460	SHANDA RENE BURNETT	PAYROLL	08/28/2013	296.04
2014	11	50461	LEAH RENEE DUMEY	PAYROLL	08/28/2013	376.78
2014	11	50462	ERIC STEVEN WALKER	PAYROLL	08/28/2013	538.25
2014	11	50463	JAMI LEEANN YOUNG	PAYROLL	08/28/2013	288.51
2014	11	50464	MARGARET ANN CORN	PAYROLL	08/28/2013	403.69
2014	11	50465	GARY LYNN STINNETT	PAYROLL	08/28/2013	4,252.18
2014	11	50466	LARRY E HYATT	PAYROLL	08/28/2013	2,771.99
2014	11	50467	JEANNE BETH JONES	PAYROLL	08/28/2013	4,144.53
2014	11	50468	CHAD A HARPER	PAYROLL	08/28/2013	412.54
2014	11	50469	CHARLES F STOVER	PAYROLL	08/28/2013	412.54
2014	11	50470	CLIF HALL PRESTIDGE	PAYROLL	08/28/2013	354.17
2014	11	50471	KYLE MARCUS WILLIAMS	PAYROLL	08/28/2013	412.54
2014	11	50472	JON MARK YATES	PAYROLL	08/28/2013	2,411.28
2014	11	50473	GLENNIS LADON RING	PAYROLL	08/28/2013	2,293.43
2014	11	50474	JEREMY R HARPER	PAYROLL	08/28/2013	3,970.65
2014	11	50475	WILLIAM E ALLEN JR	PAYROLL	08/30/2013	43.88
2014	11	50476	VICKI R BAILEY	PAYROLL	08/30/2013	28.22
2014	11	50477	DANIEL K BAKER	PAYROLL	08/30/2013	64.17
2014	11	50478	JULIE D BROWN	PAYROLL	08/30/2013	126.96
2014	11	50479	GAY L COCHERELL	PAYROLL	08/30/2013	102.42
2014	11	50480	PATTIE L CRAWFORD	PAYROLL	08/30/2013	144.21
2014	11	50481	LISA D FLOYD	PAYROLL	08/30/2013	37.62
2014	11	50482	LEE A HARRISON	PAYROLL	08/30/2013	644.20
2014	11	50483	SHERYL R HAZELBAKER	PAYROLL	08/30/2013	5,067.42
2014	11	50484	AMY VALENTINE JONES	PAYROLL	08/30/2013	84.65
2014	11	50485	J ELIZABETH JONES	PAYROLL	08/30/2013	112.86
2014	11	50486	DIANA S JUSTUS	PAYROLL	08/30/2013	33.46
2014	11	50487	BENITTA L MALEY	PAYROLL	08/30/2013	71.63
2014	11	50488	ABIGAIL C MCCUDDY	PAYROLL	08/30/2013	65.26
2014	11	50489	MICHAEL ALAN MCGARRY	PAYROLL	08/30/2013	28.22
2014	11	50490	PAUL R SHADE	PAYROLL	08/30/2013	94.98
2014	11	50491	MARGARET J STEVENS	PAYROLL	08/30/2013	77.94

MUSTANG PUBLIC SCHOOLS
Encumbrance Register
General Fund 2013-2014

<i>fYear</i>	<i>Fund</i>	<i>P.O.</i>	<i>Vendor Name</i>	<i>Description</i>	<i>eDate</i>	<i>Classified</i>
2014	11	50492	CAROL A STILL	PAYROLL	08/30/2013	55.00
2014	11	50493	BETTY L STOVER	PAYROLL	08/30/2013	50.16
2014	11	50494	ROANNA JOANETTE TALLENT	PAYROLL	08/30/2013	20.01
2014	11	50495	JENNIFER SUE TIPTON	PAYROLL	08/30/2013	51.56
2014	11	50496	LORI WALKABOUT	PAYROLL	08/30/2013	131.66
2014	11	50497	DENA L WILKES	PAYROLL	08/30/2013	508.98
2014	11	50498	CARIN MELISSA MCSPERITT	PAYROLL	08/30/2013	4,368.87
2014	11	50499	IRIS NEDEEN MARTIN	PAYROLL	08/30/2013	1,569.14
2014	11	50500	WAYNE EARL HUGHES	PAYROLL	08/30/2013	29.19
2014	11	50501	JAMES COLIAN TEEL	PAYROLL	08/30/2013	13.48
2014	11	50502	WILLIAM KEVIN BACK	PAYROLL	08/30/2013	370.23
2014	11	50503	JAMES ALLAN JOHNSON	PAYROLL	08/30/2013	24.63
2014	11	50504	TOMMY JAMES JUSTUS	PAYROLL	08/30/2013	25.02
2014	11	50505	DAN CREACH	PAYROLL	08/30/2013	4.18
2014	11	50506	JAMES LOUIS REES	PAYROLL	08/30/2013	57.45
2014	11	50507	CASEY VON PATTEN	PAYROLL	08/30/2013	3,216.98
2014	11	50508	CHRISTOPHER JON BALDWIN	PAYROLL	08/30/2013	3,623.31
2014	11	50509	KEITH EDWARD JUST	PAYROLL	08/30/2013	53.35
2014	11	50510	RICHARD ALAN WILLIS II	PAYROLL	08/30/2013	50.16
2014	11	50511	LORI DENISE WEST	PAYROLL	08/30/2013	50.16
2014	11	50512	DOROTHA F PARASICH	PAYROLL	08/30/2013	31.72
2014	11	50513	RONALD GORDEN WEST	PAYROLL	08/30/2013	28.29
2014	11	50514	CHRISTINA DAWN WALLER	PAYROLL	08/30/2013	3,216.98
2014	11	50515	JASON THOMAS STINNETT	PAYROLL	08/30/2013	19.56
2014	11	50516	AIMEE K CARMICHAEL	PAYROLL	08/30/2013	523.69
2014	11	50517	CODY DON LITTLE	PAYROLL	08/30/2013	141.07
2014	11	50518	BRANDON PERNELL LEE	PAYROLL	08/30/2013	55.64
2014	11	50519	MICHAEL F WALLACE	PAYROLL	08/30/2013	414.45
2014	11	50520	JOHN ROBERT LYNCH	PAYROLL	08/30/2013	39.12
2014	11	50521	RANDELL D BRUBAKER	PAYROLL	08/30/2013	19.56
2014	11	50522	DELIA LADAWN WICKER	PAYROLL	08/30/2013	37.53
2014	11	50523	WINDY MICHELE WOOD	PAYROLL	08/30/2013	72.50
2014	11	50524	AMANDA MICHELLE NEELY	PAYROLL	08/30/2013	3,614.93
2014	11	50525	HOLLY BROOKE DUNN	PAYROLL	08/30/2013	329.54
2014	11	50526	MEREDITH CAYE NORTON	PAYROLL	08/30/2013	550.65
2014	11	50527	VICKI WOLVERTON	PAYROLL	08/30/2013	66.51
2014	11	50528	DONALD RAY HAND	PAYROLL	08/30/2013	23.47
2014	11	50529	AMY E HOLLAND	PAYROLL	08/30/2013	3,179.11
2014	11	50530	AMBER KATHLEEN KILLMER	PAYROLL	08/30/2013	3,645.53
2014	11	50531	ROY DEAN PITCHFORD	PAYROLL	08/30/2013	396.33
2014	11	50532	RACHELLE R OWENS	PAYROLL	08/30/2013	3,097.64
2014	11	50533	TAMI DAWN COOPER	PAYROLL	08/30/2013	2,012.85
2014	11	50534	KAREN PATRICIA KIRBY	PAYROLL	08/30/2013	3,958.66
2014	11	50535	CAITLYN PAIGE BERNHARDT	PAYROLL	08/30/2013	3,095.24
2014	11	50536	JEREMY LEE DOMBEK	PAYROLL	08/30/2013	7,293.80
2014	11	50537	KAYLA RENEE HENAGAR	PAYROLL	08/30/2013	5,273.94
2014	11	50538	ANDREA MICHELLE CATHELL	PAYROLL	08/30/2013	4,070.00
2014	11	50539	JAMIE LEIGH SPRADLIN	PAYROLL	08/30/2013	3,868.98
2014	11	50540	MORGAN ASHLEY WALLS	PAYROLL	08/30/2013	3,323.35
2014	11	50541	FREDERICK L BOST	PAYROLL	08/30/2013	4,434.74
2014	11	50542	BROOKE ADELLE BARRETT	PAYROLL	08/30/2013	3,867.27
2014	11	50543	KIMBERLY BROWN	PAYROLL	08/30/2013	5,275.40
2014	11	50544	TONYA MARIE SMITHEY	PAYROLL	08/30/2013	3,664.57
2014	11	50545	ASHLEY RENE ARMSTRONG	PAYROLL	08/30/2013	3,620.96
2014	11	50546	AMY COZENS	PAYROLL	08/30/2013	3,221.80
2014	11	50547	QUINTON ELAM BLEVINS	PAYROLL	08/30/2013	3,643.96

MUSTANG PUBLIC SCHOOLS
Encumbrance Register
General Fund 2013-2014

fYear	Fund	P.O.	Vendor Name	Description	eDate	Classified
2014	11	50549	MEREDITH ALLISON HENDERSON	PAYROLL	08/30/2013	3,835.44
2014	11	50550	AYRIAL DEVIN HENSLEY	PAYROLL	08/30/2013	3,097.64
2014	11	50551	LAURA LOUISE SUTTLES	PAYROLL	08/30/2013	3,097.64
2014	11	50552	CHELSEA DAWN DOUGLAS	PAYROLL	08/30/2013	3,724.85
2014	11	50553	KRISTEN DENEVA POLSON	PAYROLL	08/30/2013	3,097.64
2014	11	50554	REBECCA M NEITZEL	PAYROLL	08/30/2013	3,730.40
2014	11	50555	CAITLIN MICHELLE TRAIL	PAYROLL	08/30/2013	3,131.57
2014	11	50556	FAITH EULALIA ENGEL	PAYROLL	08/30/2013	3,825.10
2014	11	50557	MEGAN NICHOLE CREWS	PAYROLL	08/30/2013	3,097.64
2014	11	50558	JENIECE BRIDGFORTH	PAYROLL	08/30/2013	5,396.75
2014	11	50559	CHRISTIE MICHELLE MCDUGAL	PAYROLL	08/30/2013	3,645.37
2014	11	50560	TIFFANY MARIE BOSTIC	PAYROLL	08/30/2013	3,851.25
2014	11	50561	HARLEY LYNN WEBB	PAYROLL	08/30/2013	3,641.56
2014	11	50562	LORI LINN KNOWLES	PAYROLL	08/30/2013	3,097.64
2014	11	50563	WHITNEY PAIGE BENNETT	PAYROLL	08/30/2013	3,131.57
2014	11	50564	MADISON MARIE CARTER	PAYROLL	08/30/2013	3,679.48
2014	11	50565	LAUREN RENE SHAFFER	PAYROLL	08/30/2013	3,095.07
2014	11	50566	KRISTEN ASHLEY ZUBOR	PAYROLL	08/30/2013	3,323.35
2014	11	50567	KARISSA KUHN-ARNETT	PAYROLL	08/30/2013	3,097.64
2014	11	50568	KAREN JO FRANCE	PAYROLL	08/30/2013	4,195.12
2014	11	50569	MISTY DAWN SHANKS	PAYROLL	08/30/2013	3,967.81
2014	11	50570	GINA NICHOLE THOMPSON	PAYROLL	08/30/2013	3,623.94
2014	11	50571	CHRISTY DIANE SELF	PAYROLL	08/30/2013	4,260.39
2014	11	50572	BRADLY A DICK	PAYROLL	08/30/2013	3,924.46
2014	11	50573	RACHEL MARIE THOMAS	PAYROLL	08/30/2013	5,228.30
2014	11	50574	BARBARA LINN HEIDEBRECHT	PAYROLL	08/30/2013	3,961.15
2014	11	50575	MELISSA MICHELLE SCHAFER	PAYROLL	08/30/2013	3,646.05
2014	11	50576	ERIN ELIZABETH RAIBER	PAYROLL	08/30/2013	3,771.42
2014	11	50577	MALLORY PAIGE WALTHER	PAYROLL	08/30/2013	3,807.20
2014	11	50578	ANDRA LEIGH WILLIAMS	PAYROLL	08/30/2013	3,970.16
2014	11	50579	MISTY D EIDSON	PAYROLL	08/30/2013	3,930.08
2014	11	50580	GLENDA MICHELLE SERJEANT	PAYROLL	08/30/2013	3,097.64
2014	11	50581	KAILA DANE SMITH	PAYROLL	08/30/2013	3,645.54
2014	11	50582	SAMANTHA JO GODWIN	PAYROLL	08/30/2013	3,725.42
2014	11	50583	JESSICA LEIGH POOL	PAYROLL	08/30/2013	3,232.91
2014	11	50584	TERRI LYNNE STORY	PAYROLL	08/30/2013	4,072.64
2014	11	50585	BAILEY NICOLE POOL	PAYROLL	08/30/2013	3,063.73
2014	11	50586	WHITNEY ANN WALDROP	PAYROLL	08/30/2013	3,058.73
2014	11	50587	PAULA SUE ALLISON	PAYROLL	08/30/2013	3,005.69
2014	11	50588	CARA SUE REID	PAYROLL	08/30/2013	3,768.13
2014	11	50589	BRITNEY ANN MCWILLIAMS	PAYROLL	08/30/2013	3,620.00
2014	11	50590	BETH ANN JOHNSTON	PAYROLL	08/30/2013	3,489.21
2014	11	50591	ROBERT LEE JOHNSON	PAYROLL	08/30/2013	3,689.23
2014	11	50592	CRYSTAL ANN HUGGINS	PAYROLL	08/30/2013	1,474.61
2014	11	50593	SHIELLA MARIE VARDEMAN	PAYROLL	08/30/2013	1,458.33
2014	11	50594	MELISSA CAROL VANOSDOL	PAYROLL	08/30/2013	1,518.49
2014	11	50595	AMBER SARIL WAGGONER	PAYROLL	08/30/2013	3,200.93
2014	11	50596	ALICIA MARIE YOUNG	PAYROLL	08/30/2013	1,456.58
2014	11	50597	JORDAN ASHLEY PYLE	PAYROLL	08/30/2013	965.35
2014	11	50598	FRANCES EVELYN STIDHAM	PAYROLL	08/30/2013	965.35
2014	11	50599	REBECCA ANN PRYOR	PAYROLL	08/30/2013	965.35
2014	11	50600	LINDA SUSAN NUNLEY	PAYROLL	08/30/2013	5,041.65
2014	11	50601	KRYSTAL DIANNE TURNER	PAYROLL	08/30/2013	672.93
2014	11	50602	WHITNEY LEONNA TAYLOR	PAYROLL	08/30/2013	3,097.64
2014	11	50603	CALAH CHRISTINE LYNES	PAYROLL	08/30/2013	3,221.80
2014	11	50604	MORGAN ELISE HELLER	PAYROLL	08/30/2013	3,097.64

MUSTANG PUBLIC SCHOOLS
Encumbrance Register
General Fund 2013-2014

<i>fYear</i>	<i>Fund</i>	<i>P.O.</i>	<i>Vendor Name</i>	<i>Description</i>	<i>eDate</i>	<i>Classified</i>
2014	11	50606	CATHERINE EVELYN SANDERS	PAYROLL	08/30/2013	134.91
2014	11	50607	NADIA B COFFMAN	PAYROLL	08/30/2013	774.82
2014	11	50608	ANGELICA MARIE LEDFORD	PAYROLL	08/30/2013	1,494.06
2014	11	50609	CHERYL LYNN JOHNSON	PAYROLL	08/30/2013	965.35
2014	11	50610	MARTHA JO RHODES	PAYROLL	08/30/2013	954.32
2014	11	50611	MATTHEW LEE VAUGHAN	PAYROLL	08/30/2013	3,640.88
2014	11	50612	KASEY RENEE SAUNDERS	PAYROLL	08/30/2013	3,097.64
2014	11	50613	CHASIDY LEE HULSEY	PAYROLL	08/30/2013	5,090.93
2014	11	50614	JARED SMITH PROCK	PAYROLL	08/30/2013	3,644.67
2014	11	50615	JUDITH MARIE KUCZYNSKI	PAYROLL	08/30/2013	3,221.80
2014	11	50616	BRITTANY MARIE PARKER	PAYROLL	08/30/2013	3,640.76
2014	11	50617	ALLEN WILLIAM E	PAYROLL	08/30/2013	48.44
2014	11	50618	LORI JOHNSON	PAYROLL	08/30/2013	39.22
2014	11	50619	BORDEN B CLIFTON	PAYROLL	08/30/2013	141.07
2014	11	50620	DEANN ELIZARDO	PAYROLL	08/30/2013	43.06
2014	11	50621	PATRICK COURTNEY	PAYROLL	08/30/2013	50.16
2014	11	50622	LUEON E HOWERTON	PAYROLL	08/30/2013	74.21
2014	11	50623	JOHNNIE RAY LANCASTER	PAYROLL	08/30/2013	58.55
2014	11	50624	BARNETTA NELL MOONEYHAM	PAYROLL	08/30/2013	406.38
2014	11	50625	LISA CREWS	PAYROLL	08/30/2013	43.06
2014	11	50626	CHARLES EMIL DUBOIS	PAYROLL	08/30/2013	53.35
2014	11	50627	QUENTIN LARUE PLOCH	PAYROLL	08/30/2013	24.73
2014	11	50628	YOLANDA JO HENDERSON	PAYROLL	08/30/2013	42.32
2014	11	50629	GREGORY SCOTT MANGUS	PAYROLL	08/30/2013	3,295.05
2014	11	50630	JAMIE L SIMMONS	PAYROLL	08/30/2013	37.62
2014	11	50631	CHERYL A RODGERS	PAYROLL	08/30/2013	100.31
2014	11	50632	KATELYN LAURI CAUDLE	PAYROLL	09/04/2013	3,097.63
2014	11	50633	TACEY ANN LUCAS	PAYROLL	09/04/2013	61.57

Total Printed: 601,600.49
 Total Balance Forward: 6,729,788.63
 Total to Date: 7,331,389.12

Building Fund 2013-2014
Detail Encumbrance Listing
As of 09/05/2013

PurOrder	Date	To Whom Issued / Detail Description	Po Description / Classification		
23	08/13/2013	BECKETT BROS.	055 CLEAN HS/PE GYM FLOOR		
		CLEAN, ABRABE AND APPLY TWO NEW COATS OF OIL BASE FINISH TO HS PR BLDG. GYM FLOOR FOR ROTC USE. FLOOR HAS NOT RECEIVED THIS TREATMENT IN AT LEAST FOUR YEARS WHILE USED FOR STORAGE DURING THE HS RENOVATION PROJECT.	055-2620-439-000-0000-000-053	1,356.00	
				Total Purchase Order	1,356.00
24	08/15/2013	MULLIN PLUMBING WEST DIVISION, INC.	055 PLUMBING SERVICES		
		055 WATER LINE REPAIR AT OLD VOAG AND OLD PE BLDG	055-2620-437-000-0000-000-705	5,000.00	
				Total Purchase Order	5,000.00
25	08/19/2013	HUNTER MECHANICAL & CONTROLS	021 WATER PIPE BROKE AT CREEK		
		REPLACE THE WATER FEEDER LINE FROM THE MECHANICAL ROOM AND THE COOLING TOWER. THIS IS AN EMERGENCY REPAIR WHICH WILL MEAN WE DONT HAVE TIME TO GET THREE QUOTES FROM SEVERAL VENDORS.	000-2620-433-000-0000-000-055	35,000.00	
				Total Purchase Order	35,000.00
26	08/22/2013	TIMBERLAKE CONSTRUCTION	REPAIR FENCE DUE TO STORMS		
		FURNISH AND INSTALL CHAIN LINK FENCE ON SOUTH SIDE OF BUILDING WHERE ROOF HOOD BLEW OFF BUILDING DUE TO STORMS	000-2620-459-000-0000-000-140	1,442.00	
				Total Purchase Order	1,442.00
27	08/22/2013	TIMBERLAKE CONSTRUCTION	CLEAN/PATCH HOLES FROM STORM D		
		CLEAN AND PATCH 16 HOLES/CUTS ON FLAT ROOF AT HORIZON FROM STORM DAMAGE	000-2620-458-000-0000-000-140	4,927.00	
				Total Purchase Order	4,927.00
28	08/28/2013	GRAINGER	055 SUPPLIES F/CR AND HRZ		
		PURCHASE (2) FLAMMABLE CABINETS - ONE FOR CANYON RIDGE AND ONE FOR HORIZON	055-2620-654-000-0000-000-140	962.10	
			055-2620-654-000-0000-000-145	962.10	
		PURCHASE (2) METAL STORAGE CABINETS ONE FOR EACH INTERMEDIATE SCHOOL	055-2620-654-000-0000-000-140	465.75	
			055-2620-654-000-0000-000-145	465.75	
		PURCHASE (2) 25' TAPE MEASURES FOR THE INTERMEDIATE SCHOOLS	055-2620-618-000-0000-000-140	9.64	
			055-2620-618-000-0000-000-145	9.64	
		PURCHASE (4) 170 PC TOOL KITS	055-2620-618-000-0000-000-140	286.66	
			055-2620-618-000-0000-000-145	286.66	
				Total Purchase Order	3,448.30
29	09/05/2013	TIMBERLAKE CONSTRUCTION	050 MORE ROOF REPAIR FROM STOR		
		MORE ROOF DAMAGE REPAIR FROM MAY STORMS	050-2630-430-000-0000-000-705	7,003.00	
				Total Purchase Order	7,003.00
30	09/05/2013	JOE LYNDA REITER	ACQUISITION OF PROPERTY		
		FOR PURCHASE OF LAND - SNYDER	000-4200-710-000-0000-000-050	80,000.00	
				Total Purchase Order	80,000.00
				Total Fund	138,176.30

Child Nutrition Programs Fund 2013-2014
Summary Change Order Listing
As of 09/04/2013

P.O. No.	Date	To Whom Issued	P.O. Description	Amount
32	07/01/2013	NUTRIKIDS- HEARTLAND PAYMNT SYSTE	SFTWRE LIC UPDATE & TECH SUPP'	15.00
33	07/01/2013	OFFICE DEPOT	OFFICE SUPPLIES	-588.23
131	07/08/2013	COMPLIANCE & SAFETY LLC	SAFETY DVD'S	-22.68
132	07/08/2013	OFFICE DEPOT	OFFICE SUPPLIES	-12.00
133	07/15/2013	ALL STATE HOOD CLEANING, INC.	HOOD VENT CLEANING	100.00
			Total Change Orders	-507.91

Child Nutrition Programs Fund 2013-2014
Detail Encumbrance Listing
As of 09/04/2013

PurOrder	Date	To Whom Issued / Detail Description	Po Description / Classification	
138	08/09/2013	DELL COMPUTER CORP	TRANSFER ROLLER FOR PRINTER	
		TRANSFER ROLLER FOR 5100CN PRINTER, #310-5814	176-3140-611-700-0000-000-050	28.49
				Total Purchase Order
				28.49
139	08/09/2013	DELL COMPUTER CORP	DELL COLOR PRINTER & CARTRIDGES	
		DELL C1760NW #C176AY2 COLOR PRINTER	176-3140-653-700-0000-000-050	224.99
		1400 PAGE - YELLOW #332-0408	176-3140-611-700-0000-000-050	66.49
		1400 PAGE - CYAN #332-0410	176-3140-611-700-0000-000-050	66.49
		1400 PAGE - MAGENTA #332-0409	176-3140-611-700-0000-000-050	66.49
		2000 PAGE - BLACK #332-0407	176-3140-611-700-0000-000-050	66.49
				Total Purchase Order
				490.95
140	08/09/2013	WALKER COMPANIES	NOTARY RENEWAL	
		NOTARY RENEWAL FOR TAMMY BALES AND CARMENE KROUTIL	176-3140-810-700-0000-000-050	217.00
				Total Purchase Order
				217.00
141	08/14/2013	DEALERS ELECTRICAL SUPPLY	ELECTRICAL PARTS BLANKET	
		ELECTRICAL PARTS DISTRICT WIDE BLANKET	176-3140-618-700-0000-000-050	194.68
			176-3140-618-700-0000-000-050	805.32
				Total Purchase Order
				1,000.00
142	08/14/2013	AMANDA BETH CARTER	UNIFORM REIMBURSEMENT BLKT	
		UNIFORM REIMBURSEMENT BLANKET ORDER	176-3140-657-700-0000-000-145	150.00
				Total Purchase Order
				150.00
143	08/14/2013	SANDRA LIZETH DAVIDSON	UNIFORM REIMBURSEMENT BLANKET	
		UNIFORM REIMBURSEMENT BLANKET ORDER	176-3140-657-700-0000-000-505	150.00
				Total Purchase Order
				150.00
144	08/14/2013	BEVERLY SUE GREEFF	UNIFORM REIMBURSEMENT BLANKET	
		UNIFORM REIMBURSEMENT BLANKET ORDER	176-3140-657-700-0000-000-145	150.00
				Total Purchase Order
				150.00
145	08/14/2013	CHERYL ANN MONASCO	UNIFORM REIMBURSEMENT BLKT	
		UNIFORM REIMBURSEMENT BLANKET ORDER	176-3140-657-700-0000-000-505	150.00
				Total Purchase Order
				150.00
146	08/14/2013	CATHERINE EVELYN SANDERS	UNIFORM REIMBURSEMENT BLANKET	
		UNIFORM REIMBURSEMENT BLANKET ORDER	176-3140-657-700-0000-000-120	150.00
				Total Purchase Order
				150.00
147	08/14/2013	STEPHENI EVELINA SELPH	UNIFORM REIMBURSEMENT BLKT	
		UNIFORM REIMBURSEMENT BLANKET ORDER	176-3140-657-700-0000-000-140	150.00
				Total Purchase Order
				150.00
148	08/14/2013	DIANA SHEPARD	UNIFORM REIMBURSEMENT BLANKET	
		UNIFORM REIMBURSEMENT BLANKET ORDER	176-3140-657-700-0000-000-510	150.00
				Total Purchase Order
				150.00
149	08/14/2013	AMY MASCHELL THOMPSON	UNIFORM REIMBURSEMENT BLANKET	
		UNIFORM REIMBURSEMENT BLANKET ORDER	176-3140-657-700-0000-000-145	150.00
				Total Purchase Order
				150.00
150	08/14/2013	GAIL ELLEN WALLACE	UNIFORM REIMBURSEMENT BLKT	
		UNIFORM REIMBURSEMENT BLANKET	176-3140-657-700-0000-000-110	150.00
				Total Purchase Order
				150.00

Child Nutrition Programs Fund 2013-2014
Detail Encumbrance Listing
As of 09/04/2013

PurOrder	Date	To Whom Issued / Detail Description	Po Description / Classification	
151	08/14/2013	SHARON EULENE WARREN	UNIFORM REIMBURSEMENT BLKT	
		UNIFORM REIMBURSEMENT BLANKET ORDER	176-3140-657-700-0000-000-145	150.00
			Total Purchase Order	150.00
152	08/15/2013	HUNZICKER BROTHERS, INC.	ELECTRICAL PARTS BLANKET	
		ELECTRICAL PARTS BLANKET ORDER	176-3140-618-700-0000-000-050	1,000.00
			Total Purchase Order	1,000.00
153	08/15/2013	CURTIS RESTAURANT SUPPLY	SMALL EQUIPMENT BLANKET	
		SMALL EQUIPMENT BLANKET ORDER	176-3140-618-700-0000-000-050	3,091.69
			176-3140-618-700-0000-000-050	1,908.31
			Total Purchase Order	5,000.00
154	08/15/2013	OKC WINNELSON	PLUMBING PARTS BLANKET	
		PLUMBING PARTS BLANKET ORDER	176-3140-618-700-0000-000-050	1,000.00
			Total Purchase Order	1,000.00
155	08/20/2013	CURTIS RESTAURANT SUPPLY	SMALL EQUIPMENT BLANKET	
		SMALL EQUIPMENT BLANKET ORDER	176-3140-618-700-0000-000-050	76.00
			176-3140-618-700-0000-000-050	4,924.00
			Total Purchase Order	5,000.00
156	08/20/2013	OFFICE DEPOT	OFFICE SUPPLIES	
		LETTER SIZE WALL FILES 3-PK	176-3140-619-700-0000-000-050	25.99
		3-HOLE PUNCH - SWINGLINE	176-3140-619-700-0000-000-050	15.99
		WOOD RULERS	176-3140-619-700-0000-000-050	2.98
		LETTER TRAYS - 6 PK	176-3140-619-700-0000-000-050	17.09
		CLIP BOARDS - 9 X 12 BLACK 2-PK	176-3140-619-700-0000-000-050	37.96
		QUARTET BULLETIN BOARD	176-3140-619-700-0000-000-050	49.99
		MASTERVISION - DRY ERASE EASEL	176-3140-619-700-0000-000-050	188.99
		EXPO DRY ERASE STARTER SET	176-3140-619-700-0000-000-050	9.99
		MASTER CASTER DOR STOP BIG FOOT BROWN	176-3140-619-700-0000-000-050	9.98
		AT A GLANCE 20 X 30 WALL CALENDAR	176-3140-619-700-0000-000-050	49.98
		AT A GLANCE DESK PAD CALENDARS	176-3140-619-700-0000-000-050	14.99
		PUSH PINS 50 PK	176-3140-619-700-0000-000-050	3.19
		AT A GLANCE WALL CALENDAR 8 X 11	176-3140-619-700-0000-000-050	11.99
		STANLEY BOSTITCH ELEC PENCIL SHARPENER	176-3140-619-700-0000-000-050	20.99
		SCOTCH TAPE DISPENSER	176-3140-619-700-0000-000-050	10.98
		SWINGLINE STAPLERS	176-3140-619-700-0000-000-050	53.97
		ROLODEX - 250 CARD FILE	176-3140-619-700-0000-000-050	16.99
			Total Purchase Order	542.04
157	08/20/2013	COURTNEY MICHELLE BOSARGE	UNIFORM REIMBURSEMENT BLKT	
		UNIFORM REIMBURSEMENT BLANKET ORDER	176-3140-657-700-0000-000-505	150.00
			Total Purchase Order	150.00
158	08/20/2013	BECKY JAREE BRAND	UNIFORM REIMBURSEMENT BLKT	
		UNIFORM REIMBURSEMENT BLANKET ORDER	176-3140-657-700-0000-000-110	150.00
			Total Purchase Order	150.00
159	08/20/2013	LAWRENCE EUGENE FARNSWORTH	UNIFORM REIMBURSEMENT BLKT	
		UNIFORM REIMBURSEMENT BLANKET ORDER	176-3140-657-700-0000-000-115	150.00
			Total Purchase Order	150.00
160	08/20/2013	ANNETTE LALENE FREEMAN	UNIFORM REIMBURSEMENT BLKT	72
		UNIFORM REIMBURSEMENT BLANKET ORDER	176-3140-657-700-0000-000-510	150.00
			Total Purchase Order	150.00

Child Nutrition Programs Fund 2013-2014
Detail Encumbrance Listing
As of 09/04/2013

PurOrder	Date	To Whom Issued / Detail Description	Po Description / Classification	
161	08/20/2013	LORI GAYE GENTRY	UNIFORM REIMBURSEMENT BLKT	
		UNIFORM REIMBURSEMENT BLANKET ORDER	176-3140-657-700-0000-000-145	150.00
				Total Purchase Order
				150.00
162	08/20/2013	JENNIFER RAE ROLLINS	UNIFORM REIMBURSEMENT BLKT	
		UNIFORM REIMBURSEMENT BLANKET ORDER	176-3140-657-700-0000-000-125	150.00
				Total Purchase Order
				150.00
163	08/21/2013	PLUMBCO	PLUMBING BLANKET ORDER	
		PLUMBING BLANKET ORDER	176-3140-618-700-0000-000-050	601.18
			176-3140-618-700-0000-000-050	1,898.82
				Total Purchase Order
				2,500.00
164	08/22/2013	HOBART CORPORATION	.75 HP GARBAGE DISPOSAL	
		3/4 HP GARBAGE DISPOSAL, DELIVERY AND INSTALLATION	176-3140-651-700-0000-000-140	1,720.10
				Total Purchase Order
				1,720.10
165	08/22/2013	HOBART CORPORATION	1.25 HP GARBAGE DISPOSAL	
		1.25 HP GARBAGE DISPOSAL, DELIVERY AND INSTALLATION	176-3140-651-700-0000-000-115	1,821.45
				Total Purchase Order
				1,821.45
166	08/22/2013	NUTRIKIDS- HEARTLAND PAYMNT SYSTEM	NUTRIKIDS SHIPPING	
		PIN PAD SHIPPING	176-3140-653-700-0000-000-050	8.95
				Total Purchase Order
				8.95
167	08/22/2013	NUTRI-LINK TECHNOLOGIES, INC	ONLINE APPLICATION SVC FEE	
		NUTRI-LINK ANNUAL SERVICE FEE FOR ONLINE APPLICATIONS	176-3140-810-700-0000-000-050	2,400.00
				Total Purchase Order
				2,400.00
168	08/23/2013	AMANDA SUE EMBREY	UNIFORM REIMBURSEMENT BLANKET	
		UNIFORM REIMBURSEMENT BLANKET ORDER	176-3140-657-700-0000-000-105	150.00
				Total Purchase Order
				150.00
169	08/29/2013	IVONNE DRAKE	STD LNCH RFND-HAYLEN-DALLAS-DE	
		STUDENT LUNCH REFUND FOR HAYLEN FROM MHS	176-5600-930-700-0000-000-705	50.00
		STUDENT LUNCH REFUND FOR DALLAS FROM MHS	176-5600-930-700-0000-000-705	50.00
		STUDENT LUNCH REFUND FOR DEAVEN FROM NORTH MIDDLE	176-5600-930-700-0000-000-510	50.00
				Total Purchase Order
				150.00
170	08/29/2013	NICOLETTE GOSSETT	STUDENT LUNCH REFUND-MADISON	
		STUDENT LUNCH REFUND FOR NICILETTE FROM TRAILS	176-5600-930-700-0000-000-120	50.00
				Total Purchase Order
				50.00
171	08/29/2013	BABITA NAYYAR	STUDENT LUNCH REFUND-YESHU	
		STUDENT LUNCH REFUND FOR YESHU FROM NORTH MIDDLE	176-5600-930-700-0000-000-510	50.00
				Total Purchase Order
				50.00
172	08/30/2013	SHELLI MARTINEZ	STUDENT LUNCH REFUND-KASSEDI	
		STUDENT LUNCH REFUND FOR KASSEDI FROM NORTH MIDDLE	176-5600-930-700-0000-000-510	44.40
				Total Purchase Order
				44.40
173	09/04/2013	OFFICE DEPOT	OFFICE SUPPLIES	73
		L-SHAPED DESK - CHERRY	176-3140-654-700-0000-000-050	249.99
		HUTCH WITH GLASS DOORS - CHERRY	176-3140-654-700-0000-000-050	159.99
		SMEAD HANGING FOLDER FRAME	176-3140-619-700-0000-000-050	28.98

Child Nutrition Programs Fund 2013-2014
 Detail Encumbrance Listing
 As of 09/04/2013

<i>PurOrder</i>	<i>Date</i>	To Whom Issued / Detail Description	Po Description / Classification	
173	09/04/2013	OFFICE DEPOT	OFFICE SUPPLIES	
		SHARP EL-1750V PRINTING CALCULATOR	176-3140-619-700-0000-000-050	74.97
		WILSON JONES 2" BINDER - BLACK	176-3140-619-700-0000-000-050	11.29
		WILSON JONES 3" BINDER - BLACK	176-3140-619-700-0000-000-050	28.58
		STANLEY BOSTITCH ELECTRIC PENCIL SHARPENER	176-3140-619-700-0000-000-050	20.99
		ALLSOP MOUSE PAD	176-3140-619-700-0000-000-050	9.79
		CORK BULLETIN BOARD 2' X 3'	176-3140-619-700-0000-000-050	39.99
		WILSON JONES 1 1/2" BINDER - BLACK	176-3140-619-700-0000-000-050	9.29
			Total Purchase Order	649.85
174	09/04/2013	CHRISTINA POWELL SMITH	STUDENT LUNCH REFUND-JACK	
		STUDENT LUNCH REFUND FOR JACK FROM LAKEHOMA	176-5600-930-700-0000-000-115	30.00
			Total Purchase Order	30.00
			Total Fund	26,253.23

MUSTANG PUBLIC SCHOOLS
Encumbrance Register
Child Nutrition Programs Fund 2013-2014

<i>fYear</i>	<i>Fund</i>	<i>P.O.</i>	<i>Vendor Name</i>	<i>Description</i>	<i>eDate</i>	<i>Classified</i>
2014	22	50007	KIMBERLY LYNN HOWARD	PAYROLL	08/20/2013	161.41
2014	22	50008	RHEA JANE LOGAN	PAYROLL	08/20/2013	164.51
2014	22	50009	JANATH E MEIER	PAYROLL	08/20/2013	117.13
2014	22	50010	PEGGY L RAINES	PAYROLL	08/20/2013	374.76
2014	22	50011	ROXANNE S DAVIS	PAYROLL	08/20/2013	95.49
2014	22	50012	KIMBERLY DAWN NOVOTNY	PAYROLL	08/20/2013	239.80
2014	22	50013	BRENDA K ROBERTS	PAYROLL	08/20/2013	133.82
2014	22	50014	L DENISE PERHANE	PAYROLL	08/20/2013	110.64
2014	22	50015	LINDA ANN RIGGS	PAYROLL	08/20/2013	100.12
2014	22	50016	MARY D HENDRIX	PAYROLL	08/28/2013	5,382.50
2014	22	50017	CONNIE JEAN SCOTT	PAYROLL	08/28/2013	345.38
2014	22	50018	MARJORIE MORRIS	PAYROLL	08/28/2013	365.01
2014	22	50019	BETTY JOANN JUSTUS	PAYROLL	08/28/2013	838.43
2014	22	50020	TERESA LYNN HALL	PAYROLL	08/30/2013	930.21
2014	22	50021	CHERYL ANN MONASCO	PAYROLL	08/30/2013	1,619.15

Total Printed: 10,978.36
Total Balance Forward: 1,370,286.80
Total to Date: 1,381,265.16

LEASE REVENUE BOND 2013-2014
Summary Change Order Listing
As of 09/04/2013

P.O. No.	Date	To Whom Issued	P.O. Description	Amount
2	07/01/2013	OLDHAM ACRES LANDSCAPING, INC.	ROLLOVER 2013-23-47	-685.50
10	07/01/2013	DOLESE BROS CO	ROLLOVER 2013-23-160	95.00
			Total Change Orders	-590.50

Bond Fund #31 2013-2014
Detail Encumbrance Listing
As of 09/04/2013

PurOrder	Date	To Whom Issued / Detail Description	Po Description / Classification	
2	08/28/2013	WEIDENHAMMER SYSTEMS CORPORATION	150 050 ADDITIONAL AP CHK	
		ADDITIONAL AP CHECK FOR STUDENT ACTIVITY	150-2580-653-000-0000-000-050	395.00
		STUDENT ACTIVITY CHECK		
			Total Purchase Order	395.00
			Total Fund	395.00

Bond Fund #32 2013-2014
 Detail Encumbrance Listing
 As of 09/04/2013

<i>PurOrder</i>	<i>Date</i>	To Whom Issued / Detail Description	Po Description / Classification	
3	08/14/2013	LOWES CREDIT SERVICES	WASHER/DRYER 4 HZN SPEC ED	
(1)		DRYER ITEM#365228	000-2620-654-000-0000-000-140	809.10
(1)		WASHER, ITEM#365226	000-2620-654-000-0000-000-140	809.10
(1)		DISHWASHER, ITEM#377813	000-2620-654-000-0000-000-140	224.10
(1)		WASH HOSE	000-2620-654-000-0000-000-140	25.58
(1)		5' UNIVERSAL FIT DISHWASHER HOSE	000-2620-654-000-0000-000-140	13.48
(1)		QUIT FIT KIT	000-2620-654-000-0000-000-140	17.97
(1)		4 WIRE DRYER CORD	000-2620-654-000-0000-000-140	21.59
			Total Purchase Order	1,920.92
			Total Fund	1,920.92

Bond Fund #33 2013-2014
Detail Encumbrance Listing
As of 09/04/2013

<i>PurOrder</i>	<i>Date</i>	To Whom Issued / Detail Description	Po Description / Classification	
10	08/07/2013	SOONER FLOORING, INC	159 TILE FOR HORIZON	
		10 CARTONS OF "WASHED LINEN" #51810 TILE FOR HORIZON	159-2620-618-000-0000-000-140	1,495.00
			Total Purchase Order	1,495.00
			Total Fund	1,495.00

Bond Fund #34 2013-2014
Detail Encumbrance Listing
As of 09/04/2013

<i>PurOrder</i>	<i>Date</i>	To Whom Issued / Detail Description	Po Description / Classification	
9	09/03/2013	LDS BUILDING SPECIALITIES	169 KICKDOWNS/KICKPLATES 4 INT	
		KICKDOWNS AND KICK PLATES FOR DOORS AT BOTH INTERMEDIATE SCHOOLS	169-2620-654-000-0000-000-145	1,700.00
			Total Purchase Order	1,700.00
			Total Fund	1,700.00

Bond Fund #35 2013-2014
 Detail Encumbrance Listing
 As of 09/04/2013

<i>PurOrder</i>	<i>Date</i>	To Whom Issued / Detail Description	Po Description / Classification	
11	08/19/2013	ACTION LOCK & SAFE	164 CYLINDERS/CORES 4 DOOR LOC	
		CYLINDERS AND CORES FOR DOOR LOCKS	164-2620-618-000-0000-000-140	30.00
			164-2620-618-000-0000-000-140	320.00
			Total Purchase Order	350.00
12	08/26/2013	SAI ENGINEERING	162 DESIGN ENG. 4 SOCCER SCORB	
		DESIGN ENGINEERING FOR SOCCER SCOREBOARD	162-2630-334-000-0000-000-705	995.00
			Total Purchase Order	995.00
			Total Fund	1,345.00

Bond Fund #36 2013-2014
 Detail Encumbrance Listing
 As of 09/04/2013

<i>PurOrder</i>	<i>Date</i>	To Whom Issued / Detail Description	Po Description / Classification	
31	08/30/2013	BSN SPORTS, INC.	160 BASKETBALLS FOR P.E.	
(48)		X6000 MACGREGOR INTERMEDIATE BASKETBALLS, MCX6285X	160-1000-681-000-0000-000-140	815.52
		SHIPPING	160-1000-681-000-0000-000-140	20.00
			Total Purchase Order	835.52
			Total Fund	835.52

Bond Fund #37 2013-2014
Summary Change Order Listing
As of 09/04/2013

P.O. No.	Date	To Whom Issued	P.O. Description	Amount
11	07/12/2013	SWEETWATER SOUND, INC.	165 BAND EQUIPMENT	-6.98
Total Change Orders				-6.98

Bond Fund #37 2013-2014
Detail Encumbrance Listing
As of 09/04/2013

PurOrder	Date	To Whom Issued / Detail Description	Po Description / Classification	
24	08/07/2013	BOB HURLEY FORD	161 VEHICLES FOR STAFF	
		PURCHASE TWO (2) 2014 FORD EXPLORERS FOR THE DEPUTY AND ASSISTANT SUPERINTENDENTS AND TRANSFER THEIR EXISTING VEHICLES TO THE TECHNOLOGY DEPARTMENT FOR USE BY THEIR NEW TECHNICIANS AROUND THE DISTRICT.	161-2650-769-000-0000-000-053	46,620.00
		(2) 2014 FORD EXPLORERS MODEL CODE: K7B		
		COLOR:		
		BASE PRICE: \$ 23,310.00 EACH		
			Total Purchase Order	46,620.00
25	08/07/2013	INDECO SALES	160 K-CLASS FURN TE	
		PURCHASE FURNITURE FOR NEW K-CLASS AT TRAILS ELEMENTARY.	159-2620-654-000-0000-000-053	1,055.47
		1- CUBBY WITH ASSORTED COLOR TUBS		
		4 - STORAGE SHELF UNITS		
		1 -RECTANGLE TABLE		
		1 - ROUND TABLE		
			Total Purchase Order	1,055.47
26	08/09/2013	CURTIS RESTAURANT SUPPLY	trays for Horizon	
		Lunch trays for 800 students - Horizon Intermediate	166-3140-651-700-0000-000-140	6,606.20
			Total Purchase Order	6,606.20
27	08/09/2013	INDECO SALES	159 SPARE STUDENT CHAIRS	
		PURCHASE ADDITIONAL STUDENT CHAIRS FOR THE TWO INTERMEDIATE SITES:	160-2620-654-000-0000-000-053	2,211.00
		ABC D10A 18" STACK CHAIRS @ \$ 22.11 EACH		
			Total Purchase Order	2,211.00
28	08/09/2013	SOONER FLOORING, INC	159 LABOR TO INSTALL AT HORIZO	
		LABOR TO ASSIST WITH INSTALLATION OF CARPET SQUARES AT HORIZON BAND ROOM.	159-2620-459-000-0000-000-053	1,766.00
			Total Purchase Order	1,766.00
29	08/09/2013	UNITED RENTAL	161 2011 DROP DECK TRAILER	
		PURCHASE 2011 DROP DECK TRAILER FOR MAINTENANCE AND FOOD SERVICE USE AROUND THE DISTRICT.	161-2650-769-000-0000-000-055	11,500.00
			Total Purchase Order	11,500.00
30	08/13/2013	THOMPSON EDUCATIONAL FURNISHINGS	160 K-CLASS FURNITURE	
		PURCHASE THREE WOOD DESIGN MOBILE STORAGE UNITS FOR NEW PRE-K CLASS AND K-CLASS ROOMS AT CREEK AND TRAILS	160-2620-654-000-0000-000-120 160-2620-654-000-0000-000-125	232.50 465.00
			Total Purchase Order	697.50
31	08/16/2013	MEDLEY MATERIAL HANDLING	161 ELECTRIC PALLET TRUCK	
		PURCHASE AN ELECTRIC PALLET TRUCK FOR THE FOOD SERVICE AND CUSTODIAL WAREHOUSE TO USE.	161-2650-769-000-0000-000-053	4,125.00
			Total Purchase Order	4,125.00
32	08/16/2013	VIRCO INC	160 ADMIN CONF RM TABLES	
		PURCHASE OF TEN (12) VIRCO TEXT TABLES #TT2472830 FOR USE IN THE ADMIN. BOARD ROOM.	160-2620-654-000-0000-000-053	4,284.00
				84
			Total Purchase Order	4,284.00
33	08/19/2013	MACK BRASS OF VIRGINIA	165 BAND EQUIP 4 HS	

Bond Fund #37 2013-2014
Detail Encumbrance Listing
As of 09/04/2013

PurOrder	Date	To Whom Issued / Detail Description	Po Description / Classification	
33	08/19/2013	MACK BRASS OF VIRGINIA	165 BAND EQUIP 4 HS	
(2)		COMP EUPH IN SILVER, EU1150S	165-1000-655-000-0000-000-705	1,990.00
(12)		BB TUBA, TU210L	165-1000-655-000-0000-000-705	20,100.00
		SHIPPING	165-1000-655-000-0000-000-705	315.00
			Total Purchase Order	22,405.00
34	08/19/2013	THOMPSON EDUCATIONAL FURNISHINGS	160 ADDITNL HS STUDENT DESKS	
		PURCHASE (50) ADDITIONAL STUDENT DESKS FOR THE HIGH SCHOOL. THEY ARE OUT OF SPRARE DESKS THAT WAS PURCHASED AS PART OF THE ORIGINAL RENOVATION.	160-2620-654-000-0000-000-053	4,499.50
			Total Purchase Order	4,499.50
35	08/26/2013	INDECO SALES	160 CREEK PRE-K FURNTURE	
		PURCHASE THE FOLLOWING FURNITURE FOR THE CREEK PRE-K CLASS:	160-2620-654-000-0000-000-125	1,294.52
		20 - 12" CHAIRS ----- \$ 394.80		
		(1) CUBBY RACK W/CUBBIES-----\$ 324.21		
		(1) TEACHERS EASEL -----\$ 128.15		
		(2) STORAGE CABINETS -----\$ 447.36		
			Total Purchase Order	1,294.52
36	08/28/2013	AMUNDSEN FOOD EQUIPMENT	DISHMACHINE REPLACEMENT	
		CL44e Hobart Dishwasher with S/S pressure-less 30 KW booster heater and higher than standard chamber, warranty	166-3140-731-700-0000-000-120	23,798.00
			Total Purchase Order	23,798.00
37	08/28/2013	CURTIS RESTAURANT SUPPLY	STEAMER REPLACEMENT	
		AccuTemp E6 double electric convection steamer to replace old steamer not working	166-3140-731-700-0000-000-110	13,033.82
			Total Purchase Order	13,033.82
38	08/28/2013	INDECO SALES	160 ART RM FURN FOR ME	
		PURCHASE FURNTURE FOR ART ROOM AT ME PER REQUEST OF ART TEACHER TO BETTER ACCOMODATE HIS STUDENTS	160-2620-654-000-0000-000-105	1,589.76
		(42) 16" DISCOVER STUDENT CHAIRS @ \$ 22.59 IN VARIOUS COLORS.		
		(6) 30" X 72" TABLES WITH ADJUSTABLE LEGS @ \$ 106.93 IN VARIOUS TABLE TOP COLORS		
			Total Purchase Order	1,589.76
39	08/28/2013	THOMPSON EDUCATIONAL FURNISHINGS	160 ADD'L HS STUDENT DESKS	
		PURCHASE (50) ADDITIONAL STUDENT DESKS FOR THE HS CAMPUS	160-2620-654-000-0000-000-053	4,499.50
			Total Purchase Order	4,499.50
40	08/29/2013	HUDIBURG CHEVROLET	161 VEHICILE FOR ADMIN USE	
		CHEVROLET TAHOE FOR USE BY ADMINISTRATORS	161-2640-769-000-0000-000-053	29,200.00
		BASE PRICE: \$ 28,859.00		
		OPTION: THIRD ROW SEAT - \$ 341.00		
		TOTAL PRICE: \$ 29,200.00		
			Total Purchase Order	29,200.00
41	09/03/2013	TIMBERLAKE CONSTRUCTION	158 MMH PARKING LOT	
		MMH PARKING, ALT.#4	158-2630-455-000-0000-000-140	53,287.27
			158-2630-455-000-0000-000-140	26,298.09
			Total Purchase Order	79,585.36

Bond Fund #37 2013-2014
 Detail Encumbrance Listing
 As of 09/04/2013

<i>PurOrder</i>	<i>Date</i>	To Whom Issued / Detail Description	Po Description / Classification	
42	09/03/2013	BANCFIRST	LEASE REV PAYMENT	
		LEASE REVENUE PAYMENT	150-4600-720-000-0000-000-050	5,895,886.36
			Total Purchase Order	5,895,886.36
			Total Fund	6,154,656.99

MUSTANG PUBLIC SCHOOLS
Custodians Analysis
SCHOOL ACTIVITY FUNDS

Report Options: As Of Date: 08/2013; Time Frame: For Fiscal Year; Field Order: Project; Group Totals: ; Page Break: No

	Begin Balance	Receipts	Adjusting Entries	Checks	Cash End Balance	Unpaid Purchase Orders	End Balance
Project 800 SCHOOL ACTIVITY ACCOUN	\$0.00	\$269.40	\$0.00	\$0.00	\$269.40	\$0.00	\$269.40
Project 801 INDUSTRIAL ARTS	\$542.11	\$274.06	\$0.00	\$0.00	\$816.17	\$0.00	\$816.17
Project 802 ANNUAL - H.S.	\$19,204.64	\$362.52	\$0.00	\$421.82	\$19,145.34	\$10,578.00	\$8,567.34
Project 803 HIGH SCHOOL ATHLETICS	\$77,366.00	\$13,363.64	\$0.00	\$27,380.74	\$63,348.90	\$77,935.83	(\$14,586.93)
Project 804 BAND - H.S.	\$33,056.05	\$55,202.31	\$0.00	\$5,732.90	\$82,525.46	\$76,447.30	\$6,078.16
Project 805 BOYS BASKETBALL - H.S.	\$17,645.12	\$250.90	\$0.00	\$11,092.19	\$6,803.83	\$0.00	\$6,803.83
Project 806 BOYS SOCCER - H.S.	\$16,133.87	\$1.64	\$0.00	\$3,620.46	\$12,515.05	\$200.00	\$12,315.05
Project 807 CENTENNIAL COUNSELING	\$0.00	\$0.00	\$0.00	\$0.00	\$0.00	\$1,488.00	(\$1,488.00)
Project 808 CENTENNIAL MEDIA	\$4,252.49	\$0.56	\$0.00	\$0.00	\$4,253.05	\$0.00	\$4,253.05
Project 809 D.A.R.E.	\$446.53	\$0.06	\$0.00	\$0.00	\$446.59	\$0.00	\$446.59
Project 810 MUSTANG ELEMENTARY	\$5,471.36	\$402.52	\$0.00	\$2,115.00	\$3,758.88	\$2,490.56	\$1,268.32
Project 811 ENRICHMENT ORGANIZATIO	\$7,693.39	\$1.02	\$0.00	\$0.00	\$7,694.41	\$0.00	\$7,694.41
Project 812 ART-MUSTANG VALLEY	\$7,024.58	\$115.92	\$0.00	\$5,213.20	\$1,927.30	\$766.99	\$1,160.31
Project 814 FFA - H.S.	\$24,205.73	\$880.16	\$0.00	\$1,116.00	\$23,969.89	\$2,415.00	\$21,554.89
Project 815 FCCLA - H.S.	\$1,309.37	(\$19.82)	\$0.00	\$0.00	\$1,289.55	\$405.00	\$884.55
Project 816 FRENCH CLUB - H.S.	\$1,368.65	\$0.18	\$0.00	\$0.00	\$1,368.83	\$0.00	\$1,368.83
Project 817 FRESHMEN CHEER - H.S.	\$474.59	\$0.06	\$0.00	\$0.00	\$474.65	\$400.00	\$74.65
Project 818 HIGH SCHOOL GENERAL	\$60,943.99	\$80,081.32	\$0.00	\$6,335.19	\$134,690.12	\$9,419.43	\$125,270.69
Project 819 GIRLS BASKETBALL - H.S.	\$6,473.07	\$0.46	\$0.00	\$2,915.49	\$3,558.04	\$0.00	\$3,558.04
Project 820 GIRLS TRACK - H.S.	\$1,485.51	\$0.20	\$0.00	\$0.00	\$1,485.71	\$0.00	\$1,485.71
Project 821 GIRLS VOLLEYBALL - H.S.	\$1,172.03	\$0.16	\$0.00	\$0.00	\$1,172.19	\$25.00	\$1,147.19
Project 822 GOLF-HS	\$545.07	\$0.06	\$0.00	\$0.00	\$545.13	\$0.00	\$545.13
Project 823 LAKEHOMA ELEM	\$30,086.64	\$4.22	\$2,186.63	\$47.88	\$32,229.61	\$204.28	\$32,025.33
Project 824 CENTENNIAL ART	\$61.27	\$0.02	\$0.00	\$0.00	\$61.29	\$598.64	(\$537.35)
Project 825 MEDIA-HS	\$4,964.15	\$186.96	\$0.00	\$0.00	\$5,151.11	\$0.00	\$5,151.11
Project 826 MEDIA - MS	\$1,044.82	\$0.14	\$0.00	\$0.00	\$1,044.96	\$209.00	\$835.96
Project 827 MEDIA -NORTH MS	\$11,738.35	\$403.56	\$0.00	\$0.00	\$12,141.91	\$1,088.75	\$11,053.16
Project 828 KEY CLUB HS	\$828.73	\$0.10	\$0.00	\$0.00	\$828.83	\$0.00	\$828.83
Project 829 ATHLETICS - MS	\$60,616.94	\$7,907.67	\$0.00	\$5,004.65	\$63,519.96	\$14,312.28	\$49,207.68
Project 830 BAND - MS	\$6,147.83	\$1,042.78	\$0.00	\$441.90	\$6,748.71	\$3,338.55	\$3,410.16
Project 831 CHEER - MS	\$1,528.10	\$500.20	\$0.00	\$0.00	\$2,028.30	\$0.00	\$2,028.30
Project 832 FCA -MS	\$2,460.74	\$0.32	\$0.00	\$0.00	\$2,461.06	\$0.00	\$2,461.06
Project 833 MIDDLE SCHOOL	\$14,507.34	\$2,507.34	\$3,168.00	\$592.04	\$19,590.64	\$519.80	\$19,070.84
Project 834 SKILLS FOR LIVING - MS	\$395.39	\$0.08	\$0.00	\$0.00	\$395.47	\$0.00	\$395.47
Project 835 PEP CLUB - MS	\$780.01	\$0.10	\$0.00	\$0.00	\$780.11	\$0.00	\$780.11
Project 836 SCIENCE CLUB - MS	\$62.48	\$0.02	\$0.00	\$0.00	\$62.50	\$0.00	\$62.50
Project 837 CHEER - NORTH MS	\$94.67	\$0.02	\$0.00	\$0.00	\$94.69	\$0.00	\$94.69
Project 838 STUDENT COUNCIL - MS	\$1,482.72	\$0.20	\$0.00	\$0.00	\$1,482.92	\$0.00	\$1,482.92
Project 839 VOCAL MUSIC - MS	\$13,221.01	\$1.72	\$0.00	\$105.00	\$13,117.73	\$27,046.00	(\$13,928.27)
Project 840 YEARBOOK - MS	\$9,202.49	\$1.20	\$0.00	\$0.00	\$9,203.69	\$0.00	\$9,203.69
Project 841 MUSTANG VALLEY ELEM	\$22,572.56	\$10,219.46	\$0.00	\$11,884.45	\$20,907.57	\$1,007.08	\$19,900.49
Project 842 NAT'L HONOR SOCIETY-HS	\$1,330.72	\$0.18	\$0.00	\$0.00	\$1,330.90	\$0.00	\$1,330.90
Project 843 MEDIA -CREEK	\$1,842.46	(\$26.24)	\$0.00	\$0.00	\$1,816.22	\$825.00	\$991.22
Project 844 ATHLETICS - NORTH MS	\$37,959.64	\$5,552.99	\$0.00	\$7,840.81	\$35,671.82	\$13,707.93	\$21,963.89
Project 845 BAND - NORTH MS	\$8,601.53	\$1.12	\$0.00	\$44.00	\$8,558.65	\$5,791.00	\$2,767.65
Project 847 NORTH MIDDLE SCHOOL	\$24,936.53	\$408.52	\$0.00	\$1,719.27	\$23,625.78	\$4,958.32	\$18,667.46
Project 848 POM-PON - HS	\$3,056.09	\$0.40	\$0.00	\$0.00	\$3,056.49	\$622.50	\$2,433.99
Project 849 PEP CLUB - NORTH MS	\$1,060.86	\$0.14	\$0.00	\$0.00	\$1,061.00	\$0.00	\$1,061.00
Project 850 SCIENCE CLUB - NORTH MS	\$5,079.79	\$0.66	\$0.00	\$0.00	\$5,080.45	\$0.00	\$5,080.45
Project 851 SPEECH CLUB - NORTH MS	\$51.29	\$0.02	\$0.00	\$0.00	\$51.31	\$0.00	\$51.31
Project 852 STUDENT COUNCIL - NORTI	\$639.60	\$0.08	\$0.00	\$0.00	\$639.68	\$0.00	\$639.68
Project 853 VOCAL MUSIC - NORTH MS	\$1,230.52	\$0.16	\$0.00	\$0.00	\$1,230.68	\$455.00	\$775.68
Project 854 YEARBOOK-NORTH MS	\$8,236.68	\$109.08	\$0.00	\$0.00	\$8,345.76	\$8,300.00	\$45.76
Project 855 JR CLASS - HS	\$17,912.31	(\$77.68)	\$0.00	\$0.00	\$17,834.63	\$0.00	\$17,834.63
Project 856 SCIENCE/MATH - H.S.	\$580.88	(\$18.92)	\$0.00	\$0.00	\$561.96	\$0.00	\$561.96
Project 857 SR CLASS - HS	\$56,417.01	\$11,062.36	\$0.00	\$523.00	\$66,956.37	\$5,250.00	\$61,706.37
Project 858 SPECIAL OLYMPICS	\$1,181.69	\$0.16	\$0.00	\$0.00	\$1,181.85	\$0.00	\$1,181.85
Project 859 DRAMA DEPARTMENT/CLUE	\$10,005.39	\$1.30	\$0.00	\$175.00	\$9,831.69	\$227.00	\$9,604.69
Project 860 STUDENT COUNCIL - HS	\$930.64	\$0.12	\$0.00	\$0.00	\$930.76	\$2,396.00	(\$1,465.24)
Project 861 VARSITY CHEER - HS	\$11,691.01	\$3,961.74	\$0.00	\$2,346.50	\$13,306.25	\$6,524.15	\$6,782.10
Project 862 VOCAL MUSIC - HS	\$3,839.44	\$310.50	\$0.00	\$250.00	\$3,899.94	\$5,075.00	(\$1,175.06)
Project 863 SCHOLARSHIP FUND	\$1,750.65	\$0.16	\$0.00	\$1,500.00	\$250.81	\$0.00	\$250.81
Project 864 D.E.C.A. - H.S.	\$2,098.76	\$1,851.42	\$0.00	\$0.00	\$3,950.18	\$454.00	\$3,496.18

MUSTANG PUBLIC SCHOOLS
Custodians Analysis
SCHOOL ACTIVITY FUNDS

Report Options: As Of Date: 08/2013; Time Frame: For Fiscal Year; Field Order: Project; Group Totals: ; Page Break: No

	Begin Balance	Receipts	Adjusting Entries	Checks	Cash End Balance	Unpaid Purchase Orders	End Balance
Project 865 BASEBALL - H.S.	\$24,569.66	\$2.12	\$0.00	\$8,676.05	\$15,895.73	\$7,836.87	\$8,058.86
Project 866 SIXTH GRADE - NORTH M.S.	\$887.69	\$0.12	\$0.00	\$0.00	\$887.81	\$0.00	\$887.81
Project 867 ADMINISTRATION	\$8,794.66	\$1.14	\$0.00	\$150.13	\$8,645.67	\$0.00	\$8,645.67
Project 868 MEDIA - VALLEY	\$13,260.93	\$429.67	\$0.00	\$0.00	\$13,690.60	\$1,103.21	\$12,587.39
Project 869 COUNSELING ACTIVITIES - '1	\$627.66	\$0.08	\$0.00	\$0.00	\$627.74	\$2,693.90	(\$2,066.16)
Project 870 TRAILS ELEMENTARY	\$14,725.54	\$1,786.37	\$0.00	\$3,085.49	\$13,426.42	\$1,262.30	\$12,164.12
Project 871 GIRLS SOFTBALL - H.S.	\$1,072.17	\$853.86	\$0.00	\$2,049.41	(\$123.38)	\$0.00	(\$123.38)
Project 872 SPANISH CLUB - H.S.	\$639.21	\$0.08	\$0.00	\$0.00	\$639.29	\$0.00	\$639.29
Project 873 MEDIA - MUSTANG TRAILS	\$928.61	\$0.12	\$0.00	\$0.00	\$928.73	\$249.00	\$679.73
Project 874 M.E.A.D. - MUSTANG ELEME	\$1,874.86	\$0.24	\$0.00	\$0.00	\$1,875.10	\$0.00	\$1,875.10
Project 875 DRUG FREE CLUB - TRAILS	\$1,205.11	\$0.16	\$0.00	\$0.00	\$1,205.27	\$850.00	\$355.27
Project 876 9TH-VARSITY FOOTBALL H.S.	\$19,547.84	\$8,603.20	\$0.00	\$314.09	\$27,836.95	\$31,127.50	(\$3,290.55)
Project 877 GIFTED AND TALENTED	\$1,107.48	\$0.14	\$0.00	\$0.00	\$1,107.62	\$0.00	\$1,107.62
Project 878 TRANSPORTATION	\$2,004.27	\$24.22	\$0.00	\$0.00	\$2,028.49	\$600.00	\$1,428.49
Project 879 CREEK CHOIR	\$372.12	\$0.06	\$0.00	\$0.00	\$372.18	\$0.00	\$372.18
Project 880 BOYS-GIRLS TENNIS H.S.	\$1,100.41	\$0.14	\$0.00	\$0.00	\$1,100.55	\$0.00	\$1,100.55
Project 881 L.E. DRUG FREE LEADERS	\$2,554.26	\$0.34	\$0.00	\$0.00	\$2,554.60	\$0.00	\$2,554.60
Project 882 BOYS/GIRLS CROSS COUNTRY	\$1,985.39	\$2,263.26	\$0.00	\$0.00	\$4,248.65	\$1,875.00	\$2,373.65
Project 883 GIRLS SOCCER - H.S.	\$4,739.56	\$0.62	\$0.00	\$0.00	\$4,740.18	\$0.00	\$4,740.18
Project 884 CHISHOLM TRAILS	\$1,728.69	\$0.22	\$0.00	\$98.14	\$1,630.77	\$40.00	\$1,590.77
Project 885 BUILDER'S CLUB - MS	\$293.17	\$0.04	\$0.00	\$0.00	\$293.21	\$0.00	\$293.21
Project 886 BUILDER'S CLUB - NORTH M	\$2,139.42	\$0.28	\$0.00	\$0.00	\$2,139.70	\$0.00	\$2,139.70
Project 887 DEBATE CLUB - HS	\$557.59	\$0.06	\$0.00	\$0.00	\$557.65	\$0.00	\$557.65
Project 888 MUSTANG CREEK ELEM	\$7,237.24	\$477.53	\$0.00	\$453.33	\$7,261.44	\$244.93	\$7,016.51
Project 889 MEDIA - LE	\$1,592.76	\$0.22	\$0.00	\$0.00	\$1,592.98	\$920.25	\$672.73
Project 890 RENAISSANCE - MS	\$1,087.02	\$0.14	\$0.00	\$0.00	\$1,087.16	\$381.00	\$706.16
Project 891 READING - MS	\$6,677.99	\$0.88	\$0.00	\$0.00	\$6,678.87	\$0.00	\$6,678.87
Project 892 RENAISSANCE - NORTH MS	\$1,402.14	\$0.18	\$0.00	\$0.00	\$1,402.32	\$0.00	\$1,402.32
Project 893 RENAISSANCE - HS	\$5,572.60	\$0.74	\$0.00	\$0.00	\$5,573.34	\$0.00	\$5,573.34
Project 894 SPECIAL LIFE SKILLS -MS	\$1,430.11	\$0.18	\$0.00	\$0.00	\$1,430.29	\$0.00	\$1,430.29
Project 895 TECHNOLOGY STUDENT-M	\$49.47	\$0.00	\$0.00	\$0.00	\$49.47	\$0.00	\$49.47
Project 896 ACADEMIC TEAM -HS	\$1.32	\$0.00	\$0.00	\$0.00	\$1.32	\$0.00	\$1.32
Project 897 ART CLUB -HS	\$845.55	\$2,135.10	\$0.00	\$218.68	\$2,761.97	\$207.99	\$2,553.98
Project 898 ATHLETIC TRAINING -HS	\$8,985.93	\$0.98	\$0.00	\$2,617.66	\$6,369.25	\$2,250.00	\$4,119.25
Project 899 TECHNOLOGY - NORTH MS	\$444.23	\$0.06	\$0.00	\$0.00	\$444.29	\$0.00	\$444.29
Project 900 SPANISH CLUB - MV	\$666.23	\$0.10	(\$666.33)	\$0.00	\$0.00	\$0.00	\$0.00
Project 901 P.A.S.S. - MEC	\$665.59	\$352.05	\$0.00	\$416.30	\$601.34	\$245.85	\$355.49
Project 902 CRI ACTIVITY ACCOUNT	\$0.00	\$0.26	\$2,000.00	\$105.70	\$1,894.56	\$179.83	\$1,714.73
Project 903 ADVANCED PLACEMENT -H	\$10,897.19	\$1,672.72	\$0.00	\$1,626.97	\$10,942.94	\$3,453.26	\$7,489.68
Project 904 GROUNDS IMPROVEMENT	\$1,266.11	\$0.16	\$0.00	\$0.00	\$1,266.27	\$14,168.45	(\$12,902.18)
Project 905 CRI STAFF ACCOUNT	\$0.00	\$11.67	\$4,000.00	\$1,162.80	\$2,848.87	\$540.19	\$2,308.68
Project 906 HS FRESHMAN F.C.C.L.A.	\$1,875.99	\$0.24	\$0.00	\$175.00	\$1,701.23	\$0.00	\$1,701.23
Project 907 OUTDOOR CLASSROOM - M	\$2,764.35	\$0.36	\$0.00	\$0.00	\$2,764.71	\$570.00	\$2,194.71
Project 908 GOLF - NORTH MS	\$722.17	\$0.10	\$0.00	\$0.00	\$722.27	\$0.00	\$722.27
Project 915 TRACK/CROSS COUNTRY-N	\$1,115.54	\$0.14	\$0.00	\$0.00	\$1,115.68	\$0.00	\$1,115.68
Project 916 CREEK/NORTH OUTDOOR	\$323.06	\$0.04	\$0.00	\$0.00	\$323.10	\$0.00	\$323.10
Project 918 FOOTBALL - NORTH MS	\$249.50	\$0.02	\$0.00	\$0.00	\$249.52	\$0.00	\$249.52
Project 919 LE- 5TH GRADE	\$2,186.63	\$0.00	(\$2,186.63)	\$0.00	\$0.00	\$0.00	\$0.00
Project 920 PRE-KINDERGARTEN- MEC	\$10,354.69	\$3,997.13	\$0.00	\$1,751.16	\$12,600.66	\$4,944.36	\$7,656.30
Project 921 MUSTANG EDUCATION CEN	\$1,821.51	\$0.24	(\$1,821.51)	\$0.00	\$0.24	\$0.00	\$0.24
Project 922 SPECIAL EDUCATION - M-H	\$360.21	\$0.06	\$0.00	\$0.00	\$360.27	\$0.00	\$360.27
Project 923 ART - LAKEHOMA	\$3,980.88	\$0.52	\$0.00	\$0.00	\$3,981.40	\$0.00	\$3,981.40
Project 924 MUSICAL - HS	\$5,726.21	\$0.74	\$0.00	\$0.00	\$5,726.95	\$0.00	\$5,726.95
Project 925 WRESTLING - HS	\$2.47	\$0.00	\$0.00	\$0.00	\$2.47	\$0.00	\$2.47
Project 926 JROTC - HS	\$1,425.09	\$85.93	\$0.00	\$0.00	\$1,511.02	\$0.00	\$1,511.02
Project 927 HS ATHLETIC DEPT. STAFF	\$8,453.53	\$12,699.90	\$0.00	\$6,074.70	\$15,078.73	\$8,322.91	\$6,755.82
Project 929 MUSTANG ELEMENTARY ST	\$3,661.08	\$0.82	\$2,500.00	\$1,131.64	\$5,030.26	\$411.00	\$4,619.26
Project 930 MUSTANG VALLEY STAFF	\$2,334.75	\$0.62	\$2,500.00	\$1,032.39	\$3,802.98	\$5.16	\$3,797.82
Project 931 MUSTANG LAKEHOMA STAF	\$1,948.22	\$0.58	\$2,500.00	\$141.31	\$4,307.49	\$303.00	\$4,004.49
Project 932 MUSTANG TRAILS STAFF	\$3,676.44	\$87.61	\$2,500.00	\$1,861.13	\$4,402.92	\$2,560.81	\$1,842.11
Project 933 MUSTANG CREEK STAFF	\$2,105.29	\$21.23	\$2,500.00	\$381.35	\$4,245.17	\$319.21	\$3,925.96
Project 934 MUSTANG MIDDLE SCHOOL	\$10,221.95	\$0.92	(\$3,168.00)	\$242.90	\$6,811.97	\$0.00	\$6,811.97
Project 935 MNMS STAFF	\$1,209.76	\$0.16	\$0.00	\$427.98	\$781.94	\$60.00	\$721.94

MUSTANG PUBLIC SCHOOLS
Custodians Analysis
SCHOOL ACTIVITY FUNDS

Report Options: As Of Date: 08/2013; Time Frame: For Fiscal Year; Field Order: Project; Group Totals: ; Page Break: No

	Begin Balance	Receipts	Adjusting Entries	Checks	Cash End Balance	Unpaid Purchase Orders	End Balance
Project 937 HIGH SCHOOL STAFF	\$29,331.82	\$26.00	\$0.00	\$2,011.50	\$27,346.32	\$0.00	\$27,346.32
Project 938 EDUCATION CENTER STAFF	\$1,447.81	\$0.18	\$1,821.51	\$163.24	\$3,106.26	\$325.00	\$2,781.26
Project 939 ADMINISTRATION STAFF	\$38,086.19	\$1,771.99	(\$27,000.00)	\$4,075.25	\$8,782.93	\$520.00	\$8,262.93
Project 940 HIGH SCHOOL TECH EDUC/	\$618.18	\$0.08	\$0.00	\$0.00	\$618.26	\$0.00	\$618.26
Project 941 HIGH SCHOOL BOYS TRACT	\$514.25	\$0.14	\$0.00	\$0.00	\$514.39	\$0.00	\$514.39
Project 942 HS - BUSINESS PROF. OF A	\$1,042.21	\$2,186.14	\$0.00	\$0.00	\$3,228.35	\$4,540.00	(\$1,311.65)
Project 943 MUSTANG CREEK COUNSEI	\$3,475.77	\$0.46	\$0.00	\$0.00	\$3,476.23	\$0.00	\$3,476.23
Project 944 MPS SPECIAL NEEDS	\$44.21	\$0.00	\$0.00	\$0.00	\$44.21	\$0.00	\$44.21
Project 945 MUSTANG CREEK ART	\$4,468.91	\$0.58	\$0.00	\$1,546.42	\$2,923.07	\$44.18	\$2,878.89
Project 946 ECO CLUB HIGHSCHOOL	\$255.49	\$0.04	\$0.00	\$0.00	\$255.53	\$0.00	\$255.53
Project 947 LAKEHOMA MUSIC	\$563.62	\$0.08	\$0.00	\$0.00	\$563.70	\$0.00	\$563.70
Project 948 MUSTANG TRAILS ART	\$6,101.13	\$0.80	\$0.00	\$0.00	\$6,101.93	\$0.00	\$6,101.93
Project 949 MUSTANG TRAILS HONOR C	\$109.76	\$0.02	\$0.00	\$0.00	\$109.78	\$26.99	\$82.79
Project 950 CENTENNIAL ELEMENTARY	\$19,220.62	\$1,010.91	\$0.00	\$1,326.31	\$18,905.22	\$1,354.50	\$17,550.72
Project 951 TRAILS SPECIAL ED.	\$437.92	\$0.06	\$0.00	\$0.00	\$437.98	\$0.00	\$437.98
Project 952 CENTENNIAL STAFF	\$1,134.92	\$58.48	\$2,500.00	\$0.00	\$3,693.40	\$0.00	\$3,693.40
Project 953 MUSTANG ELEM ART	\$3,794.10	(\$29.50)	\$0.00	\$0.00	\$3,764.60	\$12,007.91	(\$8,243.31)
Project 954 MUSTANG ELEM MEDIA	\$5,374.09	\$0.70	\$0.00	\$620.00	\$4,754.79	\$250.00	\$4,504.79
Project 955 TRAILS READING CARNIVAL	\$74.05	\$0.02	\$0.00	\$0.00	\$74.07	\$0.00	\$74.07
Project 956 TRAILS STUDENT COUNCIL	\$8,505.27	\$150.12	\$0.00	\$6,811.00	\$1,844.39	\$0.00	\$1,844.39
Project 957 MUSTANG TRAILS PE ACTIV	\$1,443.60	\$0.18	\$0.00	\$0.00	\$1,443.78	\$0.00	\$1,443.78
Project 959 H.S. SPANISH NAT'L HONOF	\$382.28	\$0.06	\$0.00	\$0.00	\$382.34	\$0.00	\$382.34
Project 960 H.S. MAC CHOIR	\$818.98	\$0.10	\$0.00	\$0.00	\$819.08	\$0.00	\$819.08
Project 961 H.S. VIDEO CLUB	\$2,281.83	\$20.30	\$0.00	\$929.37	\$1,372.76	\$57.05	\$1,315.71
Project 962 H.S. SWIM TEAM	\$0.34	\$90.00	\$0.00	\$0.00	\$90.34	\$0.00	\$90.34
Project 963 CREEK ARCHERY CLUB	\$394.49	\$0.06	\$0.00	\$0.00	\$394.55	\$0.00	\$394.55
Project 964 ARCHERY CLUB - MS	\$4,904.40	\$0.64	\$0.00	\$0.00	\$4,905.04	\$221.00	\$4,684.04
Project 965 VALLEY STUDENT COUNCIL	\$1,291.06	\$0.00	\$0.00	\$0.00	\$1,291.06	\$0.00	\$1,291.06
Project 966 CENTENNIAL OUTDOOR CL	\$0.00	\$20.90	\$0.00	\$0.00	\$20.90	\$0.00	\$20.90
Project 967 MUSTANG STUDENTS IN NE	\$2,506.21	\$104.30	\$0.00	\$100.00	\$2,510.51	\$0.00	\$2,510.51
Project 974 CRI SPANISH ACCT	\$0.00	\$0.00	\$666.33	\$0.00	\$666.33	\$0.00	\$666.33
Project 978 HORIZON INT ACTIVITY ACC	\$0.00	\$3,717.00	\$0.00	\$0.00	\$3,717.00	\$0.00	\$3,717.00
Project 979 HORIZON INT STAFF ACCT	\$0.00	\$0.78	\$6,000.00	\$844.56	\$5,156.22	\$774.00	\$4,382.22
Grand Total	\$1,029,724.49	\$241,750.20	\$0.00	\$151,039.45	\$1,120,435.24	\$393,328.00	\$727,107.24

**Mustang Public Schools
Monthly Interest Report
AUG 2013**

MONTHLY INTEREST TOTALS - FISCAL YEAR 2013-2014													THRU	
	JUL	AUG	SEPT	OCT	NOV	DEC	JAN	FEB	MAR	APR	MAY	JUNE	TOTALS	Aug-12
GEN FUND	120.87	1,282.24											1,403.11	\$5,027.35
BLDG - 21	16.86	13.18											30.04	\$358.08
CNS - 22	12.44	13.14											25.58	\$283.50
MAPS - 24	0.00	0.00											0.00	\$174.80
SINKING-41	91.66	423.19											514.85	\$3,162.54
Activity-60	66.48	269.40											335.88	751.00
BONDS														
#31	5.73	5.43											11.16	299.74
#32	0.90	0.84											1.74	\$37.74
#33	3.04	2.68											5.72	\$128.11
#34	3.65	3.35											7.00	\$101.75
#35	10.11	8.01											18.12	\$455.45
#36	1,921.43	1,610.47											3,531.90	\$2,367.89
#37	136.90	128.09											264.99	\$0.00
#38	0.19	0.20											0.39	\$61.14
TOTAL	2,390.26	3,760.22	0.00	0.00	0.00	0.00	0.00	0.00	0.00	0.00	0.00	0.00	\$6,150.48	\$13,209.09

YTD TOTAL

The monthly rate for BOK for AUG 13' was .2750%
The BOK Ending Balance was \$25,086,887.48

**Mustang Public Schools
Monthly Interest Report
AUG 2013**

Mustang Public Schools Board of Education
Regular Board Meeting Minutes
August 12, 2013
Maxine and George Morris Alternative/Mustang Education Center
400 North Clear Springs Road
Mustang, OK 73064
6:00 PM

AUTHORITY OF THE BOARD OF EDUCATION

As required by Section 311, Title 25 of the Oklahoma Statutes, notice is hereby given that the Board of Education of Independent School District I-069 of Canadian County, Oklahoma held a Regular Meeting on Monday, August 12, 2013 at 6:00 PM. The place and street of the meeting was the Maxine and George Morris Alternative/Mustang Education Center, 400 North Clear Springs Road, Mustang, OK 73064.

Notice of this meeting was given to the County Clerk of Canadian County, Oklahoma at least forty-eight (48) hours prior to such meeting, and public notice of this meeting, with an agenda posted in prominent view at the Mustang Education Center, 400 North Clear Springs Road, Mustang, Oklahoma, at least twenty-four (24) hours prior to this meeting, excluding Saturdays, Sundays and legal holidays, all in compliance with the Oklahoma Open Meeting Act.

Board President Chad Fulton called the meeting to order at 6:01 p.m. with Jim Davis, Amanda Strassle, Mike Kessler and Jeff Landrith present.

Superintendent's Report:

1. Board Correspondence - Thank you from 31 principals that were able to attend the NAESP conference in Baltimore over the summer.
2. Above & Beyond - Mr. McDaniel presented Clear Springs Free Will Baptist Church and Pastor Jim Harris a certificate for their project titled "The Big Give" that gave out more than 200 backpacks full of supplies, free haircuts and sacks of food.
3. Start of School - Mr. Bradley reported that enrollment numbers are at 10,051 students for Pre K-12th. Mr. Bradley recognized Jeff Woodard and many others that were instrumental in getting the two schools open for the first week of school.
4. Capital Improvement Committee Update - committee has met twice and has reached a list of immediate needs for the board to consider for a possible bond election in November.
5. Construction Update
6. District Traffic Plan
7. 2013 Spring Testing Update - Dr. Angela Mills stated we don't have scores yet, could be as last as September before we get them from SDE.

Board Reports:

Jeff Landrith and Mike Kessler reported they will be attending OSSBA conference August 23-25th, 2013.

President Chad Fulton stated he was at a meeting last week with 180 new teachers, and also toured both Intermediate Schools and was very proud.

Following a report given by Deanna Mowrey, Chief Financial Officer, on a motion made by Jim Davis and seconded by Jeff Landrith, the board voted to approve the Schedule of Encumbrances and Monthly Financial Reports:

FISCAL YEAR 2014		PAYROLL
LEASE REVENUE BOND (10)	60-76	
GENERAL FUND (11)	152-518	50295-50376
BUILDING FUND (21)	12-21	
FOOD SERVICE (22)	130-137	50002-50006
LEASE REVENUE BOND (23)		
OKC MAPS TRUST (24)		
BOND FUND (31)		
BOND FUND (32)	2	
BOND FUND (33)		
BOND FUND (34)	7-8	
BOND FUND (35)	10	
BOND FUND (36)	22-30	
BOND FUND (37)	4-23	

<u>abstain</u>	<u>aye</u>	<u>aye</u>	<u>aye</u>	<u>aye</u>
Kessler	Landrith	Strassle	Davis	Fulton

Public Participation: NONE

Consent Agenda:

On a motion made by Jim Davis and a second by Amanda Strassle, the board voted to approve all the following Consent items, which concern reports and items of a routine nature normally approved at board meetings, will be approved by one vote, unless any board member desires to have a separate vote on any or all of these items. The consent agenda consists of discussion, consideration and action on the following items that the Superintendent recommends be approved.

1. Board of Education Minutes:

- a. Regular Board Meeting - July 8, 2013

2. Activity Accounts:

- a. Transfer of \$666.23 from Mustang Valley Spanish Club #900 to Canyon Ridge Spanish Club #974.
- b. Transfer of \$1,821.51 from MEC (used as staff) #921 to MEC Staff #938, and closing of #921.

3. Out-of-District Overnight Travel:

- a. Mustang HS FFA to attend Tulsa State Fair October 1-4, 2013 in Tulsa, OK. Mr. Harris and Mr. Griffin will be sponsors for the ten (10) students.
- b. MHS Pom Team to attend the Alamo Bowl in San Antonio, TX from December 27-31st. Trip will be paid for by individual members and their booster organization.
- c. MHS Softball team to travel to Broken Arrow for a tournament on August 16-17th, 2013.

4. Use of Facilities:

- a. Optimist Club of Mustang requesting the use of Creek and Valley Elementary gymnasiums for practice for the 2013-2014 basketball

- league. They will need the gyms every Mon., Tues., Thur. and Fri. from August 15th-March 7th 2014 6:00pm -9:00 pm.
- b. Optimist Club of Mustang requesting the use of Horizon Intermediate and MNMS main gyms for games for 2013-2014 basketball leagues. They will need the gyms Fri. nights starting mid November from 5:00 - 9:00 pm, Sat. from 7:30am-9:00pm and Sundays from noon - 5:00 pm.
 - c. Optimist Club of Mustang is requesting the use of Centennial and Trails Elementary gymnasiums for practice for 2013-14 basketball leagues. They will need the gyms every Monday, Tuesday, Thursday and Friday nights from November 4th until March 7th from 6:00 pm until 9:00 pm.
5. Renewal of Contract with Canadian County Youth and Family Services for the SY 2013-2014.
 6. Renewal of Contract with Melody Thomason as Physical Therapist for SY 2013-2014.
 7. Renewal of Contract with Greta Forcina as a Speech Language Pathologist for the SY 2013-2014.
 8. Renewal of Contract with Susan Westmoreland of Westmoreland Therapy for speech language therapy for SY 2013-2014.
 9. Renewal of Contract with Stephanie Pyle as Occupational Therapist for the SY 2013-2014.
 10. Renewal of Contract with ALCA for storing student testing data in one data base for SY 2013-2014.
 11. Renewal of Contract with Edgenuity for 40 licenses for on-line course work for the SY 2013-2014.
 12. Renewal of Contract with Southern Nazarene University for Clinical Rotation for Nursing Students with no cost to District for SY 2013-2014.
 13. Renewal of Contract with Canadian County Education Center for SY 2013-2014.
 14. Renewal of Contract with parent to provide transportation to and from Putnam City Public Schools on a daily basis for deaf services for SY 2013-2014.
 15. Renewal of Contract with Maximum Health Care to provide nursing services for a student with severe medical disabilities for SY 2013-2014. This is paid from federal funds.
 16. Renewal of Contract with Putnam City Public Schools for SY 2013-2014. This contract provides transfer of students who require IEP services not available in our district, such as services for students who are deaf. All funds are paid from Federal Programs.
 17. Renewal of Contract with Rosetta Stone for the ELL (English Language Learners) program for the SY 2013-2014. This is an online language acquisition program. Estimated cost for this service is \$12,500 depending on number of participants. All costs will be paid with Federal Funds.
 18. Renewal of Contract with City of Mustang for two (2) experienced Mustang police officers for the SY 2013-2014.

19. Renewal of Contract with Canadian County Sheriff's Department for SY 2013-2014 to provide one (1) full time, on duty law enforcement officer covering MNMS, Trails Elementary, Creek Elementary, Valley Elementary and Canyon Ridge Intermediate School each day school is in session.
20. Approval of the Treasurer Certificate Forms to be filed with Cleveland, Canadian and Oklahoma County Clerk.
21. Approval of revised K-2nd grade report card to a standards based report card for SY 2013-2014.
22. Approval of District Activity Fund Handbook for SY 2013-2014.
23. Approval of District Student Handbook for SY 2013-2014.
24. Approval for new HS Activity Account: French National Honor Society.
25. Approval of new clubs for Canyon Ridge Intermediate School for SY 2013-2014 consisting of Academic Team, Photography Club, Golf Club, Science Club, Student Council, Fellowship of Christian Athletes, Cultural Club, Intramural Club, Archery, Honor Choir and Find-A-Hobby Club.
26. Approval of new clubs for Mustang Horizon Intermediate School for SY 2013-2014: 6th Grade Scholastic Club, Science Club, Student Leadership Club, 5th & 6th Honor Choir, Intramural Club and Archery Club.
27. Approval of Committee members for the District Gifted and Talented Advisory Committee for the SY 2013-2014: Connie Huffman, Amy Booth, Roxanne Davis/Parents, Bettilou Stover/Teacher, Crystal Rumbaugh/Elementary GATE teacher, Matt Moore/AP teacher, Kristi Stephens, Secondary GATE counselor, Holly McKinney/Horizon Principal, Linda Atchley/Administrative Liason
28. Approval of the Change Order #7 from Timberlake Construction for Horizon Intermediate School. This will be a decrease to the contingency of \$35,826.80.
 - a. Installation of additional outlets & data outlets
 - b. ADA Ramp, crosswalk, signage, & striping
 - c. Time and materials for chiller work
 - d. Time and materials for new hollow metal framing
 - e. Addition of outlets
 - f. Additional downspout boots and collection pipes
 - g. Provide a backflow valve
 - h. Furnish and install break metal
 - i. Add outlets in MDF Room 154
 - j. Furnish and install high moisture VCT adhesive
 - k. Deduct for particleboard used in office
29. Approval of Change Order #10 from Timberlake Construction for Sara Rd. Elementary. This will be a total decrease to the Construction Contingency by \$13,170.80.
 - a. Add monument sign at entry
 - b. Add closer, threshold, and stop to door 21D
 - c. Provide carpet moisture barrier
 - d. Modify ductwork & sprinkler system

30. Approval of awarding Sam's Club the copy paper bid for the District copy paper for the SY 2013-2014.

31. Approval of revisions to the following Policies and Procedures:

- a. Family Educational Rights and Privacy Act (FERPA), Policy #2045
- b. Acceptable Use and Safety Policy (IAUSP) #2130
- c. Enrollment of Students, Policy #5035

 abstain aye aye aye aye
Kessler Landrith Strassle Davis Fulton

Business:

1. On a motion made by Jeff Landrith and a second by Amanda Strassle the Board voted to approve the contract with Northeastern Speech Therapy, Pllc to provide speech language pathologists for the SY 2013-2014.

 aye aye aye aye aye
Kessler Landrith Strassle Davis Fulton

2. On a motion made by Jeff Landrith and a second by Jim Davis the Board voted to approve the Resolution Adopting the Canadian County Multi-Jurisdictional Multi-Hazard Mitigation Plan.

 aye aye aye aye aye
Kessler Landrith Strassle Davis Fulton

3. On a motion made by Jeff Landrith and a second by Amanda Strassle the Board voted to approve the contract with Sign Language Resource Services, Inc. (SLRS) to provide sign language interpreting as needed for employees or patrons of the Mustang School District.

 aye aye aye aye aye
Kessler Landrith Strassle Davis Fulton

4. On a motion made by Mike Kessler and a second by Jim Davis the board voted to approve the addition to Policy and Procedures #2140 Personal Technology Device (PTD) Use Policy.

 aye aye aye aye aye
Kessler Landrith Strassle Davis Fulton

5. On a motion made by Jim Davis and a second by Amanda Strassle the board voted to approve the Certificate of Substantial Completion for Canyon Ridge Intermediate School.

 aye aye aye aye aye
Kessler Landrith Strassle Davis Fulton

New Business: NONE

On a motion made by Jim Davis and a second by Mike Kessler the board voted to convene in Executive Session at 7:10 p.m.

 __aye__ __aye__ __aye__ __aye__ __aye__
Kessler Landrith Strassle Davis Fulton

1. Oklahoma Statutes Title 25, Section 307(B)(1): Discuss employment, hiring, appointment, promotion, demotion, disciplining, or resignation of an employee.
 - a. Schedule "A"
 - b. Schedule "B"
2. Oklahoma Statutes Title 25, 307 (B)(2): Discussing negotiations concerning employees and representatives of employee groups.
3. Oklahoma Statutes Title 25, 307(B)(3): Discussing the purchase or appraisal of real property.

On a motion made by Jim Davis and a second by Mike Kessler the board voted to return to Open Session at 7:51 p.m.

 __aye__ __aye__ __aye__ __aye__ __aye__
Kessler Landrith Strassle Davis Fulton

Board Clerk Amanda Strassle gave statement that she, Jeff Landrith, Chad Fulton, Jim Davis, Mike Kessler and Sean McDaniel were in Executive Session and discussed items J: 1, 2, and 3 with no action taken.

On a motion made by Jim Davis and a second by Amanda Strassle the Board voted to approve Schedule "A".

 __aye__ __aye__ __aye__ __aye__ __aye__
Kessler Landrith Strassle Davis Fulton

On a motion made by Amanda Strassle and a second by Jim Davis the Board voted to approve Schedule "B"

 __aye__ __aye__ __aye__ __aye__ __aye__
Kessler Landrith Strassle Davis Fulton

On a motion made by Jim Davis and a second by Jeff Landrith the Board voted to approve the Agreement between MEA and Mustang Board of Education for Teacher Contract for SY 2013-2014.

 __aye__ __aye__ __aye__ __aye__ __aye__
Kessler Landrith Strassle Davis Fulton

On a motion made by Jeff Landrith and a second by Mike Kessler the Board voted to adjourn at 7:52 p.m.

 __aye__ __aye__ __aye__ __aye__ __aye__
Kessler Landrith Strassle Davis Fulton

Minutes Clerk

Board President

Mustang Public Schools Request for transfer of Funds

From: VE Activity Account no 110 Quil Mitchell
Activity Fund Name Site Sponsor Signature

Please transfer funds as indicated below:

Account #	Activity Fund Account Name	Amount to be transferred
From: <u>841</u>	<u>Valley Activity Account</u>	<u>\$ 978.95</u>
From: <u>998</u>	_____	\$ _____
From: _____	_____	\$ _____
To: <u>998</u>	<u>Valley PE Activity Account</u>	<u>\$ 978.95</u>
To: _____	_____	\$ _____
To: _____	_____	\$ _____

Reason for funds to be transferred: _____

The money transferred is money raised by the PE dept and will be going into their new activity account.

Sufficient funds in account to complete transaction: Yes
(to be completed by Activity Fund Custodian) No

QMW
8-15-13
8/15/13

Board approval: _____ Approved _____
Date Disapproved _____

Board President signature: _____

Transfer completed by: _____ Date: _____

Activity Fund
Custodian

Board Memo

It is the intention of Mustang High School Technology Student Association to accept the monetary gift of \$2500 from IPS Engineering of Oklahoma City. The intention of the funds is to promote robotics and engineering at Mustang High School; therefore, we would ask the Mustang Board of Education to accept the gift. The gift is to be deposited into the account number 940 and be dispersed to the high school robotics program within the TSA organization. It will be spent on tournament dues, robotics parts, food and refreshments, and robotic equipment.

We would like to extend our greatest appreciation to the executives at IPS Engineering, and we will ensure their gracious gift will enrich the lives of the young people within the TSA organization.

Chad Harper

Mustang High School Band Department Surplus Inventory List

Item	District Serial #	Model#
Yamaha Subwoofer	1059	CW118V
Yamaha Subwoofer	1060	CW118V
Yamaha Speaker	1259	CM15V
Yamaha Speaker	0764	CW215V
Adams Marimba	083133	MCKV44
Adams Marimba	082364	MCKV44
Adams Marimba	083134	MCKV44
Musser Marimba	A0948	M350
Musser Marimba	A0330	M350
Musser Vibraphone	Q1535	M75
Musser Vibraphone	Q1531	M75



Memo

To: Tracy Skinner, Director of Secondary Schools *TS*
From: Teresa Wilkerson, Principal of Mustang High School *TW*
Date: August 29, 2013
Re: Consideration of ROTC trip *CB*

Please discuss, consider, and/or act upon this request to allow the JROTC to attend the Top of Texas Team Competition in Wichita Falls, Texas, on October 5, 2013. A formal request and specific details of the trip are attached to this memo.

Bronco Battalion



23 August 2013

To Mr. Sean McDaniel and the Mustang Public School Board;

1. The purpose of the letter is to request approval for the MHS JROTC to participate in the Top of Texas Invitational Drill Competition at Wichita Falls, Texas, on 5 October 2013. It is our plan to enter teams in the following categories;

- a) Marksmanship, 12 cadets, 3 teams (varsity & junior varsity).
- b) Color Guard, 4 cadets, 1 team (varsity).
- c) Drill Team, Unarmed, 10 cadets, 2 teams (varsity & junior varsity).
- d) Drill Team, Armed, Non-service, 10 cadets, 2 team (varsity).
- e) Drill Team, Armed, Service, 10 cadets, 1 team (varsity).
- f) Raider Challenge Physical Fitness, 16 cadets, 4 teams (2 male, 2 female).
- g) Academic Team, 5 cadets.

2. In support of this competition, we request that the Mustang School District provide one bus and one 8 passenger van to be driven by JROTC instructors. The competition will be held at S. H. Rider High School in Wichita Falls. The 8 passenger van will be used to transport equipment and to move marksmanship cadets between the main site and the marksmanship range during the event. The transportation will be the only cost to the district. All event fees will be paid by the JROTC Booster club. The cadets will be responsible for the cost of their meals.

3. We intend to depart not later than (NLT) 6:45 AM Saturday morning as our first competitive events begin at 9:00AM. We estimate our return time to be NLT 8:00PM Saturday evening.

4. This competition is fast paced and designed to promote teamwork, develop and improve leadership techniques, and build esprit de corps within the organization and the cadets. Safety is stressed in all activities.

5. We respectfully request approval of our request.

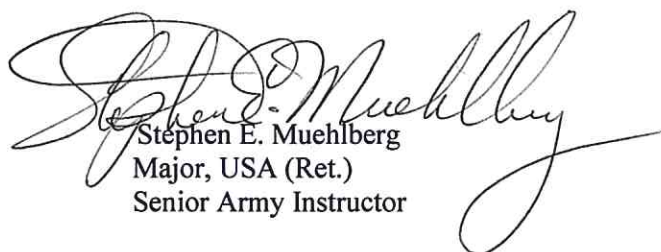
Stephen E. Muehlberg
Major, USA (Ret.)
Senior Army Instructor

MUSTANG PUBLIC SCHOOLS
 OUT OF DISTRICT, OVERNIGHT TRAVEL OR OUT OF STATE TRAVEL
 REQUEST FORM

Date of Request: 23 August 2013 Site: MHS

Staff Member Making Request: Stephen E. Muehlberg

Name of Activity: Top of Texas JROTC Teams Competition

Date/Dates of Activity: 5 October 2013

Location of Activity: H.S. Rider High School, Wichita Falls, Texas

Number of Days Students Will Miss School: N/A

Number of Students Attending Activity: 45

Number and Name(s) of Sponsor(s) Attending Activity: 3(Major Stephen E. Muehlberg, CW4 Omar Jones, MSG Jorge Moreira,)

Estimate of Expenses For Trip:

	Fund	Estimated Cost
Type of Transportation <u>Bus and van</u>	Paid by: <u>District</u>	<u>\$450.00</u>
Registration Fee _____	Paid by: <u>Booster club</u>	<u>\$385.00</u>
Registration & lunch meal paid for by the Bronco Battalion Booster Club.		
Meal Expense for Students <u>Dinner Meal (\$7.00 each)</u>	Paid by: <u>Students</u>	<u>\$280.00</u>
Meal Expense for Sponsors <u>Dinner Meal (\$7.00 each)</u>	Paid by: <u>Sponsors</u>	<u>\$21.00</u>
Room Rate for Students _____		
Number of Rooms ___ x Number of Nights = _____	Paid by: <u>N/A</u>	
Room Rate for Sponsors _____		
Number of Rooms ___ x Number of Nights = _____	Paid by: <u>N/A</u>	
Number of Days Substitute Will Be Required: <u>N/A</u>	Paid by: _____	

Estimated Total Costs: \$1,136.00

Sponsor Signature: *Stephen E. Muehlberg* (Date)

Approved by Principal <u><i>[Signature]</i></u>	<u>8/23/2013</u>
	(Date)
Approved by District Athletic Director (if applicable) _____	(Date)
Approved by Deputy Superintendent <u><i>Ches Beauf</i></u>	<u>9-3-13</u>
	(Date)

Stephen Muel

**Mustang Public Schools
Activity Tracker**

Schedule Activity

The following information has been sent for approval. You may print this your records.

- Home
- Main Options ▾
- Activity Options ▾
- Print Request Form
- Driver Options ▾
- Assistant Options ▾

ID:	14172
School/Department:	Mustang High School
Type of Fund:	Site Budget
Type of Activity:	Out of District
Additional Options:	Use of Facilities: No Custodian Services Needed: No Auditorium: No Field Trip: No Transportation: Yes
Date Needed:	10/5/2013
Date Return:	10/5/2013
Organization/Class:	MHS JROTC
Time of Activity Start:	8:00:00 AM
Time of Activity Finish:	4:30:00 PM
Location:	H.S. Rider High School - Wichita Falls, TX
Activity:	Top Of Texas JROTC Drill Competition
Number of Riders:	45
Number of Wheelchairs:	0
Sponsor in Charge:	Stephen E. Muehlberg
Sponsor Phone Number:	405-376-9334
Facilities Needed:	
Special Equipment Needed:	None
Student Liability-Release Forms:	Yes
Vehicle Type:	Bus
Time Needed:	6:0:00
Time of Departure:	6:45:00
Time of Return:	20:0:00
Loading Location:	Noth Parking Lot - MHS
Return/Dropoff Location:	Noth Parking Lot - MHS
Transportation to provide driver:	NO
If NO, Name of Driver(s):	Eric Muehlberg Jorge Moreira
Transportation to provide special needs assistant:	NA
If NO, Name of Assistant(s):	
Unusual Loads:	
Wheelchair Students:	
Bill To:	
Additional Information/Comments:	Request 1 eight passenger van to be driven Stephen Muehlberg. Van will be used to carry marksmanship and Marksmanship equipment.
P.A.S.S. Objectives:	

Error Sending Email to recipient: Debbie Schman
503 5.5.2 Need rcpt command

MUSTANG PUBLIC SCHOOLS

OUT OF DISTRICT, OVERNIGHT TRAVEL OR OUT OF STATE TRAVEL REQUEST FORM

Date of Request: 8-29-13 Site: Admin
 Staff Member Making Request: Carol Wood
 Name of Activity: ALTO Conference
 Date/Dates of Activity: Oct 15-16
 Location of Activity: Tempe Arizona
 Number of Days Students Will Miss School: _____
 Number of Students Attending Activity: _____
 Number and Name(s) of Sponsor(s) Attending Activity: Geromy Schrick, Deanna Mowrey
Carol Wood

Estimate of Expenses For Trip:

	Fund	Estimated Cost
Type of Transportation <u>Air (Geromy has a ticket)</u>	Paid by: <u>11</u>	<u>\$728</u>
Registration Fee <u>\$795 x 3 = \$2,385</u>	Paid by: <u>11</u>	<u>\$2,385</u>
<u>Rental Car if needed</u>	<u>11</u>	<u>300</u>
Meal Expense for Students _____	Paid by: <u>-</u>	<u>-</u>
Meal Expense for Sponsors _____	Paid by: <u>-</u>	<u>-</u>
Room Rate for Students _____		
Number of Rooms <u>-</u> x Number of Nights = <u>-</u>	Paid by: <u>-</u>	<u>-</u>
Room Rate for Sponsors <u>\$200</u>		
Number of Rooms <u>3</u> x Number of Nights = <u>3</u>	Paid by: <u>11</u>	<u>\$1,800</u>
<u>Per diem \$71 x 3 x 3 =</u>		<u>639</u>
Number of Days Substitute Will Be Required: _____	Paid by: <u>-</u>	<u>-</u>
# of days <u>-</u> x \$70.00 = <u>-</u> x # of sponsors <u>-</u> =		
Estimated Total Costs:		<u>\$5,852</u>

Sponsor Signature: Carol Wood 8-29-13
(Date)

Approved by Principal _____ (Date)

Approved by District Athletic Director (if applicable) _____ (Date)

Approved by Deputy Superintendent CBroelly 9-3-13
(Date)

Mustang Public Schools
Faculty Out of State Travel Request Form

Date of Request: August 30, 2013

Staff Member Making Request: Kris Green

Name of Activity: Title I National Conference

Location of Activity: San Diego

Dates of Activities: February 1st - 5th

Faculty Attending: Kris Green, Director of Federal Programs, Julie Chastain, Judy Jenkins, Shathar Bates, Title I Reading Teachers, Holly Stricker, Nikki Stein, Allison Reyes, Kathy Wilkins, Title I Math Teachers, Laurie Locke, Raylene Rhynes, Stacey Treadwell, Jackie Stafford, Title I Reading Specialists

Estimate of Expenses for Trip

Type of Transportation:	<u>Air</u>	Paid by: <u>511</u>	Estimated Cost: <u>\$4,800</u>
Registration Fee:	<u>\$549</u>	Paid by: <u>511</u>	Estimated Cost: <u>\$6,588</u>
Room Rate:	<u>\$237</u>		
Number of Rooms <u>6</u> x Number of nights <u>4</u>		Paid by: <u>511</u>	Estimated Cost: <u>\$5,688</u>
Daily Per Diem <u>\$66</u>		Paid by: <u>511</u>	Estimated Cost: <u>\$3,960</u>
Substitutes Required <u>0</u>			

Estimated Total Costs: \$21,036.00

Supervisor Signature: _____

Kris Green

(Date)

8/30/13

Approved by Deputy Superintendent _____

Charles Brady

(Date)

Memo

Date: 9/9/2013
To: Dr. Angela Mills 
From: Gaile Loving
RE: International STEM Educators Association (ISEA)

Please submit to the board for consideration and/or action upon the recommendation to send four intermediate teachers to the ISEA Conference in Branson Missouri, October 6 – 8, 2013. Funds from 311 and Title II will be used to cover the cost of the conference registration, hotel, mileage, and substitute fees for a total cost of \$3082.

Respectfully submitted,

Gaile Loving
Science Curriculum Coordinator
Mustang Public Schools

All learners need an opportunity to explore new ideas and new methods related to science, technology, engineering, and mathematics (STEM) learning. This is as true for students as it is for teachers.

The International STEM Educators Association (ISEA) conference is an integrated education conference with a focus on effective implementation of integrated STEM education into K-12 classrooms. The design of the conference will focus on a series of "hands-on" workshops that will allow teachers with an interest in STEM to actually "experience" project-based learning that can work in their classrooms. There won't be a lot of speeches at this conference, mostly hands-on professional development sessions that provide participating teachers with ideas that they can immediately take home and try.

This professional development conference strongly suggests using a team approach in order to achieve a true integration of STEM concepts across curriculum domains.

The cross-curriculum **STEM teacher-leadership team** at the intermediate grade levels of 5 and 6 will be composed of:

Tonya Smiley – Canyon Ridge, STEM Grades 5 and 6

Marti Brown – Horizon, STEM Grades 5 and 6

Tom Wolfe – Canyon Ridge, Grade 6 Science

Max Fletcher – Horizon, Grade 5 Math

Conference Location: Branson Conference Center, Branson Missouri

Hotel and Parking: Hilton Branson Convention Center Hotel.

Travel/Mileage: One teacher participant will be reimbursed for mileage at the state rate of .56 per mile, if their personal vehicle will be used. Otherwise a district vehicle will be used.

Substitutes: Teachers will miss two days only which will necessitate substitutes for Monday, October 7 and Tuesday, October 8th only.

Meals: Participants will cover the cost of their own food besides the three meals included in the registration cost.

Mustang Public Schools
Faculty Out of State Travel Request Form

Date of Request: August 30, 2013

Staff Member Making Request: Gaile Loving, Science Curriculum Coordinator

Name of Activity: International STEM Education Association (ISEA) STEM conference

Location of Activity: Branson, Missouri

Dates of Activities: October 6 - 8

Faculty Attending: Two intermediate level STEM Teachers (Marti Black, Tonya Smiley) and Intermediate science Teacher (Tom Wolfe) and one intermediate math Teacher (Max Fletcher)

Estimate of Expenses for Trip

Type of Transportation:	<u>Car</u>	Paid by: <u>333</u>	Estimated Cost: <u>\$400</u>
Registration Fee:	<u>\$270</u>	Paid by: <u>333</u>	Estimated Cost: <u>\$1080</u>
Room Rate:	<u>\$111 plus tax</u>		
Number of Rooms <u>2</u> x Number of nights <u>2</u>		Paid by: <u>333</u>	Estimated Cost: <u>\$500</u>
Parking: Number of days <u>2</u> x <u>1</u> car x <u>\$15</u> per day		Paid by: <u>333</u>	Estimated cost: <u>\$30</u>
Daily Per Diem <u>\$66</u>		Paid by: <u>Title I</u>	Estimated Cost: <u>\$792.</u>
Substitutes Required <u>4</u> x Number of days <u>2</u>		Paid by: <u>Title I</u>	Estimated Cost: <u>\$280</u>

Estimated Total Costs: \$3082

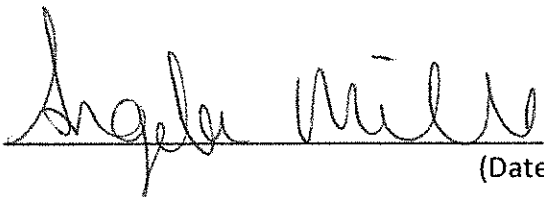
Supervisor Signature:  9-4-13
(Date)

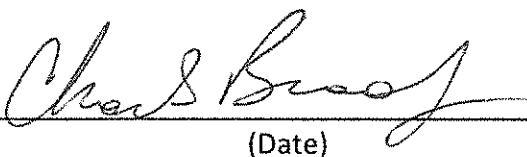
Approved by Deputy Superintendent:  9-4-13
(Date)



MUSTANG PUBLIC SCHOOLS

Use of Facility Form

GENERAL INFORMATION

APPLICANT:

Organization: OK Storm Volleyball Club

Name of Applicant: Lauren Ivy

Billing Address: 1201 W Camellia Way, Mustang, OK 73064

E-mail Address: laurenivy@cox.net

Telephone (Cell) 405-821-8887

Contact Person: Lauren Ivy

Telephone (Other) 405-256-0848

EVENT DETAILS:

Name of Activity: Club Volleyball program for Mustang area.

Purpose of Activity: Teach fundamentals and game of VB to ages 10-17.

Date(s)/Day(s) Requested: October 8 thru April 30: Tue - Thu with options of Mon if bumped for school activities.

Facility Entry Time: 6:00 am (pm) Facility Exit Time: 9:00 am (pm)

Actual Performance (if applicable) Start Time: 6:00 am (pm) End Time: 9:00 am (pm)

Expected number of participants: 45 Expected number of audience (if applicable): <10

RESPONSIBILITIES OF THE APPLICANT:

- Read the Use of Facilities and Grounds" Policy #2030. This policy provides the guidelines that are to be followed.
- Complete this form, 2030C. A copy of the board approved rental sheet is enclosed for your use in completing this form.
- Read and sign Felony Check and Sex Offender Registry statement (2030D). This form needs to be **notarized**.
- Provide a **certificate of insurance** for each request. It is the responsibility of the organization to provide a copy of an updated insurance verification if the certificate expires during the timeframe that the facility and/or grounds have been approved for use.
- I understand that upon completion of the request form, it must be returned to the MPS Administration Building Secretary along with the certificate of insurance and the Felony Checks and Sex Offender Registry form **30 days prior to the regularly scheduled board meeting**.
- Pending board approval, I understand that expenses for all facility usage will be billed following completion of the event and will be **payable upon receipt of invoice**. **Failure to promptly settle financial obligations will void future facility usage requests.**

INSURANCE REQUIREMENTS:

The user shall file a liability insurance policy with the **Mustang Board of Education**. Limits of liability shall not be less than:

\$100,000.00

Property Damage

\$100,000.00

Personal Injury each accident or occurrence

\$100,000.00

Aggregated (all claims for anyone occurrence)

The policy shall reflect an additional named insured:

Mustang Board of Education

Mustang Public School District I-69

Mustang, Oklahoma 73064

Current Insurance Verification Provided: Yes No

Expires: 9/1/13

FACILITY REQUESTED (Please refer to Policy # 2030A for the rental fees)

High School

Cafeteria
Kitchen
Commons area
Wrestling Room
MHS soccer practice field
Classrooms

MMS

Cafeteria
Kitchen
Wrestling Room
Gymnasium
Softball field
Classrooms

MNMS

Cafeteria
Kitchen
Commons Gym
Gymnasium
Softball/baseball field
Classrooms

Horizon Intermediate

Main Gym Only

Elementary Schools (Please select a site)

Mustang Elementary
Centennial Elementary
Lakehoma Elementary
Trails Elementary
Creek Elementary
Valley Elementary

Facility

Cafeteria
Kitchen
Gymnasium
Playing Field
Classrooms

Total to be invoiced:

(office use only)

Custodial Fees: Custodial fees apply for the use of cafeterias, gymnasiums, wrestling rooms and classrooms. Fees are only charged for Saturday and/or Sunday use with a two (2) hour minimum.

Number of participants: 45 Number of Mustang students participating: 40

Will admission be charged: Yes No

Special Equipment Needed: Volleyball standards and nets for 2 courts

AGREEMENT:

- We (I), OK Storm VB Club understand that we (I) are (am) to assume all damages to facilities, disappearance of equipment and costs of unauthorized usage.
- We (I), assume full liability for the care and the use of the facility and agree not to hold the school district liable for anything arising of our (my) use of the Mustang Public School facility. We (I) certify that no registered sex offenders are working this/these events(s).
- We (I) further agree to indemnify and save harmless the Mustang School District and the Mustang Board of Education from and against any and all claims and demands whether for injuries to persons or loss of life, or damage to property occurring within the Mustang Schools facility and arising out of the use and occupancy of said facility by us (me), our (my) employees, guests, members, participants and invitees.

Representative's Signature: _____

Lauren M. G.

Date: 8/19/13

OFFICE USE ONLY:

Estimated Charge for Use of Facility

Rental of Facility:

Custodial Costs:

Other:

TOTAL COST:

Signatures:

Use of Facilities Coordinator:



Date: 9-3-13

Athletic Director (if applicable):

Date:

Deputy Superintendent of Schools:



Date: 9-5-13

President of Mustang Board of Education:

Date:

CERTIFICATE OF INSURANCE

DATE: 8/22/2012

CERTIFICATE NUMBER: 20120822088823

AGENCY:

ESIX Entertainment & Sports Insurance eXperts
5660 New Northside Drive, Suite 640
Atlanta, GA 30328
Phone: (678) 324-3300 Fax: (678) 324-3303

THIS CERTIFICATE IS ISSUED AS A MATTER OF INFORMATION ONLY AND CONFERS NO RIGHTS UPON THE CERTIFICATE HOLDER. THIS CERTIFICATE DOES NOT AMEND, EXTEND OR ALTER THE COVERAGE AFFORDED BY THE POLICIES BELOW.

NAMED INSURED:

USA Volleyball (Oklahoma Region) OKRVA
4065 Sinton Road, Suite 200 2741 NW 162ND
Colorado Springs CO 80907 Edmond OK 73013

INSURERS AFFORDING COVERAGE:

INSURER A: AXIS Insurance Company (NAIC# 37273)

POLICY/COVERAGE INFORMATION:

THE POLICIES OF INSURANCE LISTED BELOW HAVE BEEN ISSUED TO THE INSURED NAMED ABOVE FOR THE POLICY PERIOD INDICATED. NOTWITHSTANDING ANY REQUIREMENT, TERM OR CONDITION OF ANY CONTRACT OR OTHER DOCUMENT WITH RESPECT TO WHICH THIS CERTIFICATE MAY BE ISSUED OR MAY PERTAIN, THE INSURANCE AFFORDED BY THE POLICIES DESCRIBED HEREIN IS SUBJECT TO ALL THE TERMS, EXCLUSIONS AND CONDITIONS OF SUCH POLICIES. AGGREGATE LIMITS SHOWN MAY HAVE BEEN REDUCED BY PAID CLAIMS.

INS	TYPE OF INSURANCE:	POLICY NUMBER(S):	EFFECTIVE:	EXPIRES:	LIMITS:
A	GENERAL LIABILITY				
	X Occurrence	AXGL05100172-12	9/1/2012 12:01 AM	9/1/2013 12:01 AM	GENERAL AGGREGATE (Applies Per Event) \$5,000,000
	X Participant Legal Liability				EACH OCCURRENCE \$1,000,000
					DAMAGE TO RENTED PREMISES (Each Occ.) \$1,000,000
					MEDICAL EXPENSE (Any one person) EXCLUDED
					PERSONAL & ADV INJURY \$1,000,000
					PRODUCTS-COMP/OP AGG \$1,000,000

DESCRIPTION OF OPERATIONS/LOCATIONS/VEHICLES/EXCLUSIONS ADDED BY ENDORSEMENT/SPECIAL PROVISIONS:

Evidence of Coverage Only.

All participants must be registered with a regional volleyball association in order for coverage to apply. No coverage will apply for regions and clubs for events conducted in which all participants are not USAV members.

Coverage applies to the above Insureds with respect to sanctioned USAV and Regional Volleyball Association events, effective the date of this certificate issuance.

Coverage available under policy #SRG 911 1239 is on file with the policyholder - Accident Medical Coverage \$25,000, deductible \$250 - Accidental Death & Dismemberment \$10,000. Policy effective date: September 1, 2012 / Policy expiration date: September 1, 2013.

CERTIFICATE HOLDER:

Mustang Public Schools - Mustang Mid High C/o Mustang Board Of Education
430 Forester Mustang Ok 73064
430 Forester
Mustang 73064

NOTICE OF CANCELLATION:

Should any of the above described policies be cancelled before the expiration date thereof, notice will be delivered in accordance with the policy provisions.

AUTHORIZED REPRESENTATIVE:



CERTIFICATE OF INSURANCE

DATE: 8/22/2012

CERTIFICATE NUMBER: 20120822088749

AGENCY:

ESIX Entertainment & Sports Insurance eXperts
5660 New Northside Drive, Suite 640
Atlanta, GA 30328
Phone: (678) 324-3300 Fax: (678) 324-3303

THIS CERTIFICATE IS ISSUED AS A MATTER OF INFORMATION ONLY AND CONFERS NO RIGHTS UPON THE CERTIFICATE HOLDER. THIS CERTIFICATE DOES NOT AMEND, EXTEND OR ALTER THE COVERAGE AFFORDED BY THE POLICIES BELOW.

NAMED INSURED:

USA Volleyball (Oklahoma Region)
4065 Sinton Road, Suite 200
Colorado Springs CO 80907

INSURERS AFFORDING COVERAGE:

INSURER A: AXIS Insurance Company (NAIC# 37273)

POLICY/COVERAGE INFORMATION:

THE POLICIES OF INSURANCE LISTED BELOW HAVE BEEN ISSUED TO THE INSURED NAMED ABOVE FOR THE POLICY PERIOD INDICATED. NOTWITHSTANDING ANY REQUIREMENT, TERM OR CONDITION OF ANY CONTRACT OR OTHER DOCUMENT WITH RESPECT TO WHICH THIS CERTIFICATE MAY BE ISSUED OR MAY PERTAIN, THE INSURANCE AFFORDED BY THE POLICIES DESCRIBED HEREIN IS SUBJECT TO ALL THE TERMS, EXCLUSIONS AND CONDITIONS OF SUCH POLICIES. AGGREGATE LIMITS SHOWN MAY HAVE BEEN REDUCED BY PAID CLAIMS.

INS	TYPE OF INSURANCE:	POLICY NUMBER(S):	EFFECTIVE:	EXPIRES:	LIMITS:
A	GENERAL LIABILITY				
X	Occurrence	AXGL05100172-12	9/1/2012 12:01 AM	9/1/2013 12:01 AM	GENERAL AGGREGATE (Applies Per Event) \$5,000,000
X	Participant Legal Liability				EACH OCCURRENCE \$1,000,000
					DAMAGE TO RENTED PREMISES (Each Occ.) \$1,000,000
					MEDICAL EXPENSE (Any one person) EXCLUDED
					PERSONAL & ADV INJURY \$1,000,000
					PRODUCTS-COMP/OP AGG \$1,000,000

DESCRIPTION OF OPERATIONS/LOCATIONS/VEHICLES/EXCLUSIONS ADDED BY ENDORSEMENT/SPECIAL PROVISIONS:

Evidence of Coverage Only.

All participants must be registered with a regional volleyball association in order for coverage to apply. No coverage will apply for regions and clubs for events conducted in which all participants are not USAV members.

Coverage applies to the above Insureds with respect to sanctioned USAV and Regional Volleyball Association events, effective the date of this certificate issuance.

Coverage available under policy #SRG 911 1239 is on file with the policyholder - Accident Medical Coverage \$25,000, deductible \$250 - Accidental Death & Dismemberment \$10,000. Policy effective date: September 1, 2012 / Policy expiration date: September 1, 2013.

CERTIFICATE HOLDER:

Mustang Middle School C/O Beverly Adams
1145 South Heights
Mustang 73064

NOTICE OF CANCELLATION:

Should any of the above described policies be cancelled before the expiration date thereof, notice will be delivered in accordance with the policy provisions.

AUTHORIZED REPRESENTATIVE:



CERTIFICATE OF INSURANCE

DATE: 8/22/2013

CERTIFICATE NUMBER: 20130820183321

AGENCY:

ESIX Entertainment & Sports Insurance eXperts
5660 New Northside Drive, Suite 640
Atlanta, GA 30328
Phone: (678) 324-3300 Fax: (678) 324-3303

THIS CERTIFICATE IS ISSUED AS A MATTER OF INFORMATION ONLY AND CONFERS NO RIGHTS UPON THE CERTIFICATE HOLDER. THIS CERTIFICATE DOES NOT AMEND, EXTEND OR ALTER THE COVERAGE AFFORDED BY THE POLICIES BELOW.

NAMED INSURED:

USA Volleyball (Oklahoma Region)
4065 Sinton Road, Suite 200
Colorado Springs CO 80907

OKRVA
2741 NW 162ND
Edmond OK 73013

INSURERS AFFORDING COVERAGE:

INSURER A: AXIS Insurance Company (NAIC# 37273)

POLICY/COVERAGE INFORMATION:

THE POLICIES OF INSURANCE LISTED BELOW HAVE BEEN ISSUED TO THE INSURED NAMED ABOVE FOR THE POLICY PERIOD INDICATED. NOTWITHSTANDING ANY REQUIREMENT, TERM OR CONDITION OF ANY CONTRACT OR OTHER DOCUMENT WITH RESPECT TO WHICH THIS CERTIFICATE MAY BE ISSUED OR MAY PERTAIN, THE INSURANCE AFFORDED BY THE POLICIES DESCRIBED HEREIN IS SUBJECT TO ALL THE TERMS, EXCLUSIONS AND CONDITIONS OF SUCH POLICIES. AGGREGATE LIMITS SHOWN MAY HAVE BEEN REDUCED BY PAID CLAIMS.

INS	TYPE OF INSURANCE:	POLICY NUMBER(S):	EFFECTIVE:	EXPIRES:	LIMITS:
A	GENERAL LIABILITY				
	X Occurrence	AXGL06100172-13	9/1/2013 12:01 AM	9/1/2014 12:01 AM	GENERAL AGGREGATE (Applies Per Event) \$5,000,000
	X Participant Legal Liability				EACH OCCURRENCE \$1,000,000
					DAMAGE TO RENTED PREMISES (Each Occ.) \$1,000,000
					MEDICAL EXPENSE (Any one person) EXCLUDED
					PERSONAL & ADV INJURY \$1,000,000
					PRODUCTS-COMP/OP AGG \$1,000,000

DESCRIPTION OF OPERATIONS/LOCATIONS/VEHICLES/EXCLUSIONS ADDED BY ENDORSEMENT/SPECIAL PROVISIONS:

Evidence of Coverage Only.

All participants must be registered with a regional volleyball association in order for coverage to apply. No coverage will apply for regions and clubs for events conducted in which all participants are not USAV members.

Coverage applies to the above Insureds with respect to sanctioned USAV and Regional Volleyball Association events, effective the date of this certificate issuance.

Coverage is available under a Participant Accident policy with National Union Fire Insurance Company of Pittsburgh on file with the policyholder - Accident Medical Coverage \$25,000, deductible \$250 - Accidental Death & Dismemberment \$10,000. Policy effective date: September 1, 2013 / Policy expiration date: September 1, 2014.

CERTIFICATE HOLDER:

Mustang Public Schools - Mustang Mid High C/o Mustang Board Of Education
430 Forester Mustang Ok 73064
430 Forester
Mustang OK 73064

NOTICE OF CANCELLATION:

Should any of the above described policies be cancelled before the expiration date thereof, notice will be delivered in accordance with the policy provisions.

AUTHORIZED REPRESENTATIVE:

FELONY CHECKS & SEX OFFENDER REGISTRY

As a representative of the organization that is requesting to use a Mustang Public School facility and/or grounds, this letter is to acknowledge that all the employees/coaches of the organization have clean felony checks and are not listed as sex offenders.

[Handwritten Signature] _____ 23 Aug 13 _____
Signature of Representative Date

STATE OF: Oklahoma

COUNTY OF: Canadian

Subscribed and sworn to before me this 23rd day of August, 2013

[Handwritten Signature] _____
Signature of Notary Public



Adopted: 08-14-06



MUSTANG PUBLIC SCHOOLS

Use of Facility Form

GENERAL INFORMATION

APPLICANT

Organization: Latchkey Child Services, Inc.
 Name of Applicant: Linda L. Cohn
 Address: 1141 N. Robinson Suite 404, OKC, OK 73103
 Billing Address: same Telephone (Work) 405-236-2069
 Contact Person: Linda Cohn Telephone (Home) 405-826-8892

EVENT DETAILS

Name of Activity: Before & After School Program
 Purpose of Activity: Provide supervised activities during out-of-school time
 Date(s)/Day(s) Requested: 2013-2014 school year
 Facility Entry Time 6:30 am @ pm 2:30 Facility Exit Time 8:00 am @ pm 6:30
 Actual Performance (if applicable) Start time n/a am pm End Time n/a am pm
 Expected number of participants 70 Expected number of audience (if applicable) n/a

RESPONSIBILITIES OF THE APPLICANT

- Read the Use of Facilities and Grounds" Policy #2030. This policy provides the guidelines that are to be followed.
- Complete this form, 2030C, front and back. A copy of the board approved rental sheet is enclosed for your use in completing this form.
- Read and sign Felony Check and Sex Offender Registry statement (2030D). This form needs to be notarized.
- Provide a certificate of insurance for each request. It is the responsibility of the organization to provide a copy of an updated insurance verification if the certificate expires during the timeframe that the facility and/or grounds have been approved for use.
- I understand that upon completion of the form, it must be returned to the Administrative Assistant's office along with the certificate of insurance and the Felony Checks and Sex Offender Registry form 30 days prior to the regularly scheduled board meeting.
- I understand that expenses for all facilities will be billed following the board meeting at which approval is granted and will be payable upon receipt of invoice. Payment is to be received by MPS before the facility can be used.

INSURANCE REQUIREMENTS

The user shall file a liability insurance policy with the Mustang Board of Education. Limits of liability shall not be less than:

\$100,000.00	Property Damage
\$100,000.00	Personal Injury each accident or occurrence
\$100,000.00	Aggregated (all claims for anyone occurrence)

The policy shall reflect an additional named insured: Mustang Board of Education
 Mustang Public School District I-69
 Mustang, Oklahoma 73064

Current Insurance Verification Provided: Yes No Expires: 7-1-2013

FACILITY REQUESTED (Please refer to Policy # 2030D for the rental fees)

<u>High School</u>	<u>Mid-High</u>	<u>MMS</u>	<u>MNMS</u>
Cafeteria	Cafeteria	Cafeteria	Cafeteria
Kitchen	Kitchen	Kitchen	Kitchen
PE building	Wrestling Room	Wrestling Room	Wrestling Room
Wrestling Room	Gymnasium	Gymnasium	Gymnasium
MHS soccer practice field		Softball field	Softball/baseball field

Elementary Schools (Please select a site)

- Mustang Elementary
- Centennial Elementary
- Lakehoma Elementary
- Trails Elementary
- Creek Elementary
- Valley Elementary

Facility

- Cafeteria
- Kitchen
- Gymnasium
- Playing Field

Total to be invoiced:

(office use only)

Custodial Fees: Custodial fees apply for the use of cafeterias, gymnasiums, wrestling rooms and classrooms. Fees are only charged for Saturday and/or Sunday use with a two (2) hour minimum.

Number of participants: 70 Number of Mustang students participating: 70

Will admission be charged: Yes No

Special Equipment Needed: none

AGREEMENT

We (I), Latahkey Child Services understand that we (I) are (am) to assume all damages to facilities, disappearance of equipment and costs of unauthorized usage.
 We (I), assume full liability for the care and the use of the facility and agree not to hold the school district liable for anything arising of our (my) use of the Mustang Public School facility. We (I) certify that no registered sex offenders are working this/these events(s).
 We (I) further agree to indemnify and save harmless the Mustang School District and the Mustang Board of Education from and against any and all claims and demands whether for injuries to persons or loss of life, or damage to property occurring within the Mustang Schools facility and arising out of the use and occupancy of said facility by us (me), our (my) employees, guests, members, participants and invitees.

Representative's Signature: [Signature] Date: 5-1-13

OFFICE USE

Estimated Charge for Use of Facility

Rental of Facility: _____ Custodial Costs: _____ Other: _____

TOTAL COST: _____

Signatures:

Administrative Assistant: [Signature]

Athletic Director (If applicable): _____
 Superintendent of Schools: [Signature]

President of Mustang Board of Education: _____

Date: 9-3-13
 Date: _____ Date: _____
 Date: 9-5-13
 Date: _____

FELONY CHECKS & SEX OFFENDER REGISTRY

As a representative of the organization that is requesting to use a Mustang Public School facility and/or grounds, this letter is to acknowledge that all the employees/coaches of the organization have clean felony checks and are not listed as sex offenders.

[Handwritten Signature]

5-1-13

Signature of Representative

Date

STATE OF: Oklahoma

COUNTY OF: Oklahoma

Subscribed and sworn to before me this 1st day of May, 2013.

[Handwritten Signature: Kathy Sue Day]

Signature of Notary Public



SEAL

Adopted: 08-14-06



CERTIFICATE OF LIABILITY INSURANCE

DATE (MM/DD/YYYY)
7/12/2012

THIS CERTIFICATE IS ISSUED AS A MATTER OF INFORMATION ONLY AND CONFERS NO RIGHTS UPON THE CERTIFICATE HOLDER. THIS CERTIFICATE DOES NOT AFFIRMATIVELY OR NEGATIVELY AMEND, EXTEND OR ALTER THE COVERAGE AFFORDED BY THE POLICIES BELOW. THIS CERTIFICATE OF INSURANCE DOES NOT CONSTITUTE A CONTRACT BETWEEN THE ISSUING INSURER(S), AUTHORIZED REPRESENTATIVE OR PRODUCER, AND THE CERTIFICATE HOLDER.

IMPORTANT: If the certificate holder is an ADDITIONAL INSURED, the policy(ies) must be endorsed. If SUBROGATION IS WAIVED, subject to the terms and conditions of the policy, certain policies may require an endorsement. A statement on this certificate does not confer rights to the certificate holder in lieu of such endorsement(s).

PRODUCER The Insurance Center Agency, Inc. 9020 N May Ave. Suite 160 Oklahoma City OK 73120-4489	CONTACT NAME: Linda Kirk CISR	FAX (A/C No.): (405) 843-3208	
	PHONE (A/C No. Ext): (405) 843-0793	E-MAIL ADDRESS: linda@ticokc.com	
INSURED Latchkey Child Services, Inc. 1141 N. Robinson, Ste 404 Oklahoma City OK 73103	INSURER(S) AFFORDING COVERAGE		NAIC #
	INSURER A: Stonington Insurance Co		
	INSURER B:		
	INSURER C:		
	INSURER D:		
	INSURER E:		

COVERAGES CERTIFICATE NUMBER: 12/13 Master REVISION NUMBER:

THIS IS TO CERTIFY THAT THE POLICIES OF INSURANCE LISTED BELOW HAVE BEEN ISSUED TO THE INSURED NAMED ABOVE FOR THE POLICY PERIOD INDICATED. NOTWITHSTANDING ANY REQUIREMENT, TERM OR CONDITION OF ANY CONTRACT OR OTHER DOCUMENT WITH RESPECT TO WHICH THIS CERTIFICATE MAY BE ISSUED OR MAY PERTAIN, THE INSURANCE AFFORDED BY THE POLICIES DESCRIBED HEREIN IS SUBJECT TO ALL THE TERMS, EXCLUSIONS AND CONDITIONS OF SUCH POLICIES. LIMITS SHOWN MAY HAVE BEEN REDUCED BY PAID CLAIMS.

INSR ITR	TYPE OF INSURANCE	ADDL SUBR INSR WORD	POLICY NUMBER	POLICY EFF (MM/DD/YYYY)	POLICY EXP (MM/DD/YYYY)	LIMITS
A	GENERAL LIABILITY		CCP30038025	7/1/2012	7/1/2013	EACH OCCURRENCE \$ 1,000,000
	<input checked="" type="checkbox"/> COMMERCIAL GENERAL LIABILITY					DAMAGE TO RENTED PREMISES (Ea occurrence) \$ 100,000
	<input type="checkbox"/> CLAIMS-MADE <input checked="" type="checkbox"/> OCCUR					MED EXP (Any one person) \$ 5,000
	GENTL AGGREGATE LIMIT APPLIES PER:					
	<input checked="" type="checkbox"/> POLICY <input type="checkbox"/> PRO-JECT <input type="checkbox"/> LOC					GENERAL AGGREGATE \$ 3,000,000
						PRODUCTS - COMPOF AGG \$ 3,000,000
A	AUTOMOBILE LIABILITY		CCP30038025	7/1/2012	7/1/2013	COMBINED SINGLE LIMIT (Ea accident) \$
	<input type="checkbox"/> ANY AUTO	<input type="checkbox"/> SCHEDULED AUTOS				BODILY INJURY (Per person) \$
	<input type="checkbox"/> ALL OWNED AUTOS	<input type="checkbox"/> NON-OWNED AUTOS				BODILY INJURY (Per accident) \$
	<input type="checkbox"/> HIRED AUTOS					PROPERTY DAMAGE (Per accident) \$
						\$
	UMBRELLA LIAB	<input type="checkbox"/> OCCUR				EACH OCCURRENCE \$
	EXCESS LIAB	<input type="checkbox"/> CLAIMS-MADE				AGGREGATE \$
	DED	RETENTION \$				\$
	WORKERS COMPENSATION AND EMPLOYERS' LIABILITY					WC STATU-TORY LIMITS OTH-ER
	ANY PROPRIETOR/PARTNER/EXECUTIVE OFFICER/MEMBER EXCLUDED? (Mandatory in NH)	Y/N	N/A			E.L. EACH ACCIDENT \$
	If yes, describe under DESCRIPTION OF OPERATIONS below					E.L. DISEASE - EA EMPLOYEE \$
						E.L. DISEASE - POLICY LIMIT \$

DESCRIPTION OF OPERATIONS / LOCATIONS / VEHICLES (Attach ACORD 101, Additional Remarks Schedule, if more space is required)

CERTIFICATE HOLDER

Mustang Public Schools
1141 N. Robinson, ste 404
Oklahoma City, OK 73103

CANCELLATION

SHOULD ANY OF THE ABOVE DESCRIBED POLICIES BE CANCELLED BEFORE THE EXPIRATION DATE THEREOF, NOTICE WILL BE DELIVERED IN ACCORDANCE WITH THE POLICY PROVISIONS.

AUTHORIZED REPRESENTATIVE

S. H. Green CPCU/LLA



CERTIFICATE OF LIABILITY INSURANCE

DATE (MM/DD/YYYY)
7/9/2013

THIS CERTIFICATE IS ISSUED AS A MATTER OF INFORMATION ONLY AND CONFERS NO RIGHTS UPON THE CERTIFICATE HOLDER. THIS CERTIFICATE DOES NOT AFFIRMATIVELY OR NEGATIVELY AMEND, EXTEND OR ALTER THE COVERAGE AFFORDED BY THE POLICIES BELOW. THIS CERTIFICATE OF INSURANCE DOES NOT CONSTITUTE A CONTRACT BETWEEN THE ISSUING INSURER(S), AUTHORIZED REPRESENTATIVE OR PRODUCER, AND THE CERTIFICATE HOLDER.

IMPORTANT: If the certificate holder is an **ADDITIONAL INSURED**, the policy(ies) must be endorsed. If **SUBROGATION IS WAIVED**, subject to the terms and conditions of the policy, certain policies may require an endorsement. A statement on this certificate does not confer rights to the certificate holder in lieu of such endorsement(s).

PRODUCER The Insurance Center Agency, Inc. 9020 N May Ave. Suite 160 Oklahoma City OK 73120-4489		CONTACT NAME: Linda Kirk CISR PHONE (A/C No. Ext.): (405) 843-0793 FAX (A/C. No.): (405) 843-3208 E-MAIL ADDRESS: linda@ticoko.com	
INSURED Latchkey Child Services, Inc. 1141 N. Robinson, Ste 404 Oklahoma City OK 73103		INSURER(S) AFFORDING COVERAGE INSURER A: Markel Insurance Company INSURER B: Continental Western Ins Co 10804 INSURER C: INSURER D: INSURER E: INSURER F:	

COVERAGES **CERTIFICATE NUMBER:** 13/14 Master **REVISION NUMBER:**

THIS IS TO CERTIFY THAT THE POLICIES OF INSURANCE LISTED BELOW HAVE BEEN ISSUED TO THE INSURED NAMED ABOVE FOR THE POLICY PERIOD INDICATED. NOTWITHSTANDING ANY REQUIREMENT, TERM OR CONDITION OF ANY CONTRACT OR OTHER DOCUMENT WITH RESPECT TO WHICH THIS CERTIFICATE MAY BE ISSUED OR MAY PERTAIN, THE INSURANCE AFFORDED BY THE POLICIES DESCRIBED HEREIN IS SUBJECT TO ALL THE TERMS EXCLUSIONS AND CONDITIONS OF SUCH POLICIES. LIMITS SHOWN MAY HAVE BEEN REDUCED BY PAID CLAIMS.

INSR LTR	TYPE OF INSURANCE	ADDL INSR	SUBR WVD	POLICY NUMBER	POLICY EFF (MM/DD/YYYY)	POLICY EXP (MM/DD/YYYY)	LIMITS
A	GENERAL LIABILITY			CCP20001419	7/1/2013	7/1/2014	EACH OCCURRENCE \$ 1,000.00
	<input checked="" type="checkbox"/> COMMERCIAL GENERAL LIABILITY						DAMAGE TO RENTED PREMISES (Ea occurrence) \$ 100.00
	<input type="checkbox"/> CLAIMS-MADE <input checked="" type="checkbox"/> OCCUR						MED EXP (Any one person) \$ 10.00
							PERSONAL & ADV INJURY \$ 1,000.00
	GEN'L AGGREGATE LIMIT APPLIES PER:						GENERAL AGGREGATE \$ 3,000.00
	<input checked="" type="checkbox"/> POLICY <input type="checkbox"/> PROJECT <input type="checkbox"/> LOC						PRODUCTS - COMP/OP AGG \$ 3,000.00
B	AUTOMOBILE LIABILITY			CAA0480114-34	7/1/2013	7/1/2014	COMBINED SINGLE LIMIT (Ea accident) \$ 500.00
	<input checked="" type="checkbox"/> ANY AUTO						BODILY INJURY (Per person) \$
	<input type="checkbox"/> ALL OWNED AUTOS	<input type="checkbox"/> SCHEDULED AUTOS					BODILY INJURY (Per accident) \$
	<input type="checkbox"/> HIRED AUTOS	<input type="checkbox"/> NON-OWNED AUTOS					PROPERTY DAMAGE (Per accident) \$
	UMBRELLA LIAB						EACH OCCURRENCE \$
	EXCESS LIAB						AGGREGATE \$
	RETENTION \$						\$
	WORKERS COMPENSATION AND EMPLOYERS' LIABILITY						WC STATUTORY LIMITS \$
	ANY PROPRIETOR/PARTNER/EXECUTIVE OFFICER/MEMBER EXCLUDED? (Mandatory in NH)		N/A				E.L. EACH ACCIDENT \$
	If yes, describe under DESCRIPTION OF OPERATIONS below.						E.L. DISEASE - EA EMPLOYEE \$
							E.L. DISEASE - POLICY LIMIT \$

DESCRIPTION OF OPERATIONS / LOCATIONS / VEHICLES (Attach ACORD 101, Additional Remarks Schedule, if more space is required)

CERTIFICATE HOLDER Mustang Public Schools 1141 N. Robinson, ste 404 Oklahoma City, OK 73103	CANCELLATION SHOULD ANY OF THE ABOVE DESCRIBED POLICIES BE CANCELLED BEFORE THE EXPIRATION DATE THEREOF, NOTICE WILL BE DELIVERED IN ACCORDANCE WITH THE POLICY PROVISIONS.
	AUTHORIZED REPRESENTATIVE S.H. Green CPCU/LLA



MUSTANG PUBLIC SCHOOLS

Use of Facility Form

GENERAL INFORMATION

APPLICANT

Organization: Latchkey Child Services, Inc.
 Name of Applicant: Linda L. Cohn
 Address: 1141 N. Robinson Suite 404, OKC, OK 73103
 Billing Address: same Telephone (Work) 405-236-2069
 Contact Person: Linda Cohn Telephone (Home) 405-826-8822

EVENT DETAILS

Name of Activity: Before & After School Program
 Purpose of Activity: Provide supervised activities during out-of-school time
 Date(s)/Day(s) Requested: 2013-2014 school year
 Facility Entry Time 6:30 am @ pm 2:30 Facility Exit Time 8:00 am @ pm 6:30
 Actual Performance (if applicable) Start time n/a am pm End Time n/a am pm
 Expected number of participants 70 Expected number of audience (if applicable) n/a

RESPONSIBILITIES OF THE APPLICANT

- Read the Use of Facilities and Grounds' Policy #2030. This policy provides the guidelines that are to be followed.
- Complete this form, 2030C, front and back. A copy of the board approved rental sheet is enclosed for your use in completing this form.
- Read and sign Felony Check and Sex Offender Registry statement (2030D). This form needs to be notarized.
- Provide a certificate of insurance for each request. It is the responsibility of the organization to provide a copy of an updated insurance verification if the certificate expires during the timeframe that the facility and/or grounds have been approved for use.
- I understand that upon completion of the form, it must be returned to the Administrative Assistant's office along with the certificate of insurance and the Felony Checks and Sex Offender Registry form 30 days prior to the regularly scheduled board meeting.
- I understand that expenses for all facilities will be billed following the board meeting at which approval is granted and will be payable upon receipt of invoice. Payment is to be received by MPS before the facility can be used.

INSURANCE REQUIREMENTS

The user shall file a liability insurance policy with the Mustang Board of Education. Limits of liability shall not be less than:

\$100,000.00	Property Damage
\$100,000.00	Personal Injury each accident or occurrence
\$100,000.00	Aggregated (all claims for anyone occurrence)

The policy shall reflect an additional named insured: Mustang Board of Education
 Mustang Public School District I-69
 Mustang, Oklahoma 73064

Current Insurance Verification Provided: Yes No Expires: 7-1-2013

FACILITY REQUESTED (Please refer to Policy # 2030D for the rental fees)

<u>High School</u>	<u>Mid-High</u>	<u>MMS</u>	<u>MNMS</u>
Cafeteria	Cafeteria	Cafeteria	Cafeteria
Kitchen	Kitchen	Kitchen	Kitchen
PE building	Wrestling Room	Wrestling Room	Wrestling Room
Wrestling Room	Gymnasium	Gymnasium	Gymnasium
MHS soccer practice field		Softball field	Softball/baseball field

Elementary Schools (Please select a site)

Facility

- Mustang Elementary
- Centennial Elementary
- Lakehoma Elementary
- Trails Elementary
- Creek Elementary
- Valley Elementary

- Cafeteria
- Kitchen
- Gymnasium
- Playing Field

Total to be invoiced:

(office use only)

Custodial Fees: Custodial fees apply for the use of cafeterias, gymnasiums, wrestling rooms and classrooms. Fees are only charged for Saturday and/or Sunday use with a two (2) hour minimum.

Number of participants: 70 Number of Mustang students participating: 70

Will admission be charged: Yes No

Special Equipment Needed: none

AGREEMENT

We (I), Latchkey Child Services understand that we (I) are (am) to assume all damages to facilities, disappearance of equipment and costs of unauthorized usage.

We (I), assume full liability for the care and the use of the facility and agree not to hold the school district liable for anything arising of our (my) use of the Mustang Public School facility. We (I) certify that no registered sex offenders are working this/these event(s).

We (I) further agree to indemnify and save harmless the Mustang School District and the Mustang Board of Education from and against any and all claims and demands whether for injuries to persons or loss of life, or damage to property occurring within the Mustang Schools facility and arising out of the use and occupancy of said facility by us (me), our (my) employees, guests, members, participants and invitees.

Representative's Signature: [Signature] Date: 5-1-13

OFFICE USE

Estimated Charge for Use of Facility

Rental of Facility: _____ Custodial Costs: _____ Other: _____

TOTAL COST: _____

Signatures:

Administrative Assistant: [Signature]

Date: 9-3-13

Athletic Director (if applicable): _____

Date: _____ Date: _____

Superintendent of Schools: [Signature]

Date: 9-5-13

President of Mustang Board of Education: _____

Date: _____

FELONY CHECKS & SEX OFFENDER REGISTRY

As a representative of the organization that is requesting to use a Mustang Public School facility and/or grounds, this letter is to acknowledge that all the employees/coaches of the organization have clean felony checks and are not listed as sex offenders.

[Handwritten Signature] _____ 5-1-13
Signature of Representative Date

STATE OF: Oklahoma

COUNTY OF: Oklahoma

Subscribed and sworn to before me this 1st day of May, 2013.

[Handwritten Signature: Kathy Sue Day]
Signature of Notary Public



SEAL

Adopted: 08-14-06



CERTIFICATE OF LIABILITY INSURANCE

DATE (MM/DD/YYYY)
7/12/2012

THIS CERTIFICATE IS ISSUED AS A MATTER OF INFORMATION ONLY AND CONFERS NO RIGHTS UPON THE CERTIFICATE HOLDER. THIS CERTIFICATE DOES NOT AFFIRMATIVELY OR NEGATIVELY AMEND, EXTEND OR ALTER THE COVERAGE AFFORDED BY THE POLICIES BELOW. THIS CERTIFICATE OF INSURANCE DOES NOT CONSTITUTE A CONTRACT BETWEEN THE ISSUING INSURER(S), AUTHORIZED REPRESENTATIVE OR PRODUCER, AND THE CERTIFICATE HOLDER.

IMPORTANT: If the certificate holder is an ADDITIONAL INSURED, the policy(ies) must be endorsed. If SUBROGATION IS WAIVED, subject to the terms and conditions of the policy, certain policies may require an endorsement. A statement on this certificate does not confer rights to the certificate holder in lieu of such endorsement(s).

PRODUCER The Insurance Center Agency, Inc. 9020 N May Ave. Suite 160 Oklahoma City OK 73120-4489		CONTACT NAME: Linda Kirk CISR PHONE (A/C No. Ext): (405) 843-0793 FAX (A/C No.): (405) 843-3208 E-MAIL ADDRESS: linda@ticokc.com															
INSURED Latchkey Child Services, Inc. 1141 N. Robinson, Ste 404 Oklahoma City OK 73103		<table border="1"> <tr> <th>INSURER(S) AFFORDING COVERAGE</th> <th>NAIC #</th> </tr> <tr> <td>INSURER A: Stonington Insurance Co</td> <td></td> </tr> <tr> <td>INSURER B:</td> <td></td> </tr> <tr> <td>INSURER C:</td> <td></td> </tr> <tr> <td>INSURER D:</td> <td></td> </tr> <tr> <td>INSURER E:</td> <td></td> </tr> <tr> <td>INSURER F:</td> <td></td> </tr> </table>		INSURER(S) AFFORDING COVERAGE	NAIC #	INSURER A: Stonington Insurance Co		INSURER B:		INSURER C:		INSURER D:		INSURER E:		INSURER F:	
INSURER(S) AFFORDING COVERAGE	NAIC #																
INSURER A: Stonington Insurance Co																	
INSURER B:																	
INSURER C:																	
INSURER D:																	
INSURER E:																	
INSURER F:																	

COVERAGES CERTIFICATE NUMBER: 12/13 Master REVISION NUMBER:

THIS IS TO CERTIFY THAT THE POLICIES OF INSURANCE LISTED BELOW HAVE BEEN ISSUED TO THE INSURED NAMED ABOVE FOR THE POLICY PERIOD INDICATED. NOTWITHSTANDING ANY REQUIREMENT, TERM OR CONDITION OF ANY CONTRACT OR OTHER DOCUMENT WITH RESPECT TO WHICH THIS CERTIFICATE MAY BE ISSUED OR MAY PERTAIN, THE INSURANCE AFFORDED BY THE POLICIES DESCRIBED HEREIN IS SUBJECT TO ALL THE TERMS, EXCLUSIONS AND CONDITIONS OF SUCH POLICIES. LIMITS SHOWN MAY HAVE BEEN REDUCED BY PAID CLAIMS.

INSR LTR	TYPE OF INSURANCE	ADDL SUBR INSR: Y/N/D	POLICY NUMBER	POLICY EFF (MM/DD/YYYY)	POLICY EXP (MM/DD/YYYY)	LIMITS
A	GENERAL LIABILITY <input checked="" type="checkbox"/> COMMERCIAL GENERAL LIABILITY <input type="checkbox"/> CLAIMS-MADE <input checked="" type="checkbox"/> OCCUR		CCP30038025	7/1/2012	7/1/2013	EACH OCCURRENCE \$ 1,000,000 DAMAGE TO RENTED PREMISES (Ea occurrence) \$ 100,000 MED EXP (Any one person) \$ 5,000 PERSONAL & ADV INJURY \$ 1,000,000 GENERAL AGGREGATE \$ 3,000,000 PRODUCTS - COMP/OP AGG \$ 3,000,000
	GENL AGGREGATE LIMIT APPLIES PER: <input checked="" type="checkbox"/> POLICY <input type="checkbox"/> PRO-JECT <input type="checkbox"/> LOC					
A	AUTOMOBILE LIABILITY <input type="checkbox"/> ANY AUTO <input type="checkbox"/> ALL OWNED AUTOS <input type="checkbox"/> HIRED AUTOS <input type="checkbox"/> SCHEDULED AUTOS <input type="checkbox"/> NON-OWNED AUTOS		CCP30038025	7/1/2012	7/1/2013	COMBINED SINGLE LIMIT (Ea accident) \$ BODILY INJURY (Per person) \$ BODILY INJURY (Per accident) \$ PROPERTY DAMAGE (Per accident) \$
	UMBRELLA LIAB <input type="checkbox"/> OCCUR EXCESS LIAB <input type="checkbox"/> CLAIMS-MADE DED: RETENTION \$					
	WORKERS COMPENSATION AND EMPLOYERS' LIABILITY ANY PROPRIETOR/PARTNER/EXECUTIVE OFFICER/MEMBER EXCLUDED? (Mandatory in NH) If yes, describe under DESCRIPTION OF OPERATIONS below	Y/N	N/A			WC STATU- TORY LIMITS: OTH- ER: E.L. EACH ACCIDENT \$ E.L. DISEASE - EA EMPLOYEE \$ E.L. DISEASE - POLICY LIMIT \$

DESCRIPTION OF OPERATIONS / LOCATIONS / VEHICLES (Attach ACORD 101, Additional Remarks Schedule, if more space is required)

CERTIFICATE HOLDER

Mustang Public Schools
 1141 N. Robinson, ste 404
 Oklahoma City, OK 73103

CANCELLATION

SHOULD ANY OF THE ABOVE DESCRIBED POLICIES BE CANCELLED BEFORE THE EXPIRATION DATE THEREOF, NOTICE WILL BE DELIVERED IN ACCORDANCE WITH THE POLICY PROVISIONS.

AUTHORIZED REPRESENTATIVE

S.H. Green CPCU/LLA



MUSTANG PUBLIC SCHOOLS

Use of Facility Form

GENERAL INFORMATION

APPLICANT

Organization: Latchky Child Services, Inc.
 Name of Applicant: Linda L. Cohn
 Address: 1141 N. Robinson Suite 404, OKC, OK 73103
 Billing Address: same Telephone (Work) 405-236-2069
 Contact Person: Linda Cohn Telephone (Home) 405-826-8892

EVENT DETAILS

Name of Activity: Before & After School Program
 Purpose of Activity: Provide supervised activities during out-of-school time
 Date(s)/Day(s) Requested: 2013 - 2014 school year
 Facility Entry Time 6:30 am @ pm 2:30 Facility Exit Time 8:00 am @ pm 6:30
 Actual Performance (if applicable) Start time n/a am pm End Time n/a am pm
 Expected number of participants 80 Expected number of audience (if applicable) n/a

RESPONSIBILITIES OF THE APPLICANT

- Read the Use of Facilities and Grounds' Policy #2030. This policy provides the guidelines that are to be followed.
- Complete this form, 2030C, front and back. A copy of the board approved rental sheet is enclosed for your use in completing this form.
- Read and sign Felony Check and Sex Offender Registry statement (2030D). This form needs to be notarized.
- Provide a certificate of insurance for each request. It is the responsibility of the organization to provide a copy of an updated insurance verification if the certificate expires during the timeframe that the facility and/or grounds have been approved for use.
- Understand that upon completion of the form, it must be returned to the Administrative Assistant's office along with the certificate of insurance and the Felony Checks and Sex Offender Registry form **30 days prior to the regularly scheduled board meeting.**
- Understand that expenses for all facilities will be billed following the board meeting at which approval is granted and will be payable upon receipt of invoice. Payment is to be received by MPS before the facility can be used.

INSURANCE REQUIREMENTS

The user shall file a liability insurance policy with the Mustang Board of Education. Limits of liability shall not be less than:

\$100,000.00	Property Damage
\$100,000.00	Personal Injury each accident or occurrence
\$100,000.00	Aggregated (all claims for anyone occurrence)

The policy shall reflect an additional named insured: Mustang Board of Education
 Mustang Public School District I-69
 Mustang, Oklahoma 73064

Current Insurance Verification Provided: Yes No Expires: 7-1-2013

FACILITY REQUESTED (Please refer to Policy # 2030D for the rental fees)

<u>High School</u>	<u>Mid-High</u>	<u>MMS</u>	<u>MNMS</u>
Cafeteria	Cafeteria	Cafeteria	Cafeteria
Kitchen	Kitchen	Kitchen	Kitchen
PE building	Wrestling Room	Wrestling Room	Wrestling Room
Wrestling Room	Gymnasium	Gymnasium	Gymnasium
MHS soccer practice field		Softball field	Softball/baseball field

Elementary Schools (Please select a site)

Facility

Mustang Elementary	<input checked="" type="checkbox"/> Cafeteria	Total to be invoiced:	
Centennial Elementary	Kitchen		(office use only)
Lakehoma Elementary	Gymnasium		
<input checked="" type="checkbox"/> Trails Elementary	Playing Field		
Creek Elementary			
Valley Elementary			

Custodial Fees: Custodial fees apply for the use of cafeterias, gymnasiums, wrestling rooms and classrooms. Fees are only charged for Saturday and/or Sunday use with a two (2) hour minimum.

Number of participants: 80 Number of Mustang students participating: 80

Will admission be charged: Yes No

Special Equipment Needed: none

AGREEMENT

We (I), Latahkey Child Services understand that we (I) are (am) to assume all damages to facilities, disappearance of equipment and costs of unauthorized usage.

We (I), assume full liability for the care and the use of the facility and agree not to hold the school district liable for anything arising of our (my) use of the Mustang Public School facility. We (I) certify that no registered sex offenders are working this/these events(s).

We (I) further agree to indemnify and save harmless the Mustang School District and the Mustang Board of Education from and against any and all claims and demands whether for injuries to persons or loss of life, or damage to property occurring within the Mustang Schools facility and arising out of the use and occupancy of said facility by us (me), our (my) employees, guests, members, participants and invitees.

Representative's Signature: [Signature] Date: 5-1-13

OFFICE USE

Estimated Charge for Use of Facility

Rental of Facility: Custodial Costs: Other:

TOTAL COST:

Signatures:

Administrative Assistant: [Signature]

Date: 9-3-13

Athletic Director (If applicable): [Signature]

Date: _____ Date: _____

Superintendent of Schools: [Signature]

Date: 9-5-13

President of Mustang Board of Education:

Date: _____

FELONY CHECKS & SEX OFFENDER REGISTRY

As a representative of the organization that is requesting to use a Mustang Public School facility and/or grounds, this letter is to acknowledge that all the employees/coaches of the organization have clean felony checks and are not listed as sex offenders.

[Handwritten Signature] _____ 5-1-13
Signature of Representative Date

STATE OF: Oklahoma
COUNTY OF: Oklahoma

Subscribed and sworn to before me this 1st day of May, 2013.

[Handwritten Signature: Kathy Sue Day]
Signature of Notary Public

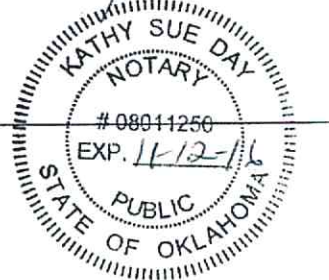

SEAL

Adopted: 08-14-06



CERTIFICATE OF LIABILITY INSURANCE

DATE (MM/DD/YYYY)
7/12/2012

THIS CERTIFICATE IS ISSUED AS A MATTER OF INFORMATION ONLY AND CONFERS NO RIGHTS UPON THE CERTIFICATE HOLDER. THIS CERTIFICATE DOES NOT AFFIRMATIVELY OR NEGATIVELY AMEND, EXTEND OR ALTER THE COVERAGE AFFORDED BY THE POLICIES BELOW. THIS CERTIFICATE OF INSURANCE DOES NOT CONSTITUTE A CONTRACT BETWEEN THE ISSUING INSURER(S), AUTHORIZED REPRESENTATIVE OR PRODUCER, AND THE CERTIFICATE HOLDER.

IMPORTANT: If the certificate holder is an ADDITIONAL INSURED, the policy(ies) must be endorsed. If SUBROGATION IS WAIVED, subject to the terms and conditions of the policy, certain policies may require an endorsement. A statement on this certificate does not confer rights to the certificate holder in lieu of such endorsement(s).

PRODUCER The Insurance Center Agency, Inc. 9020 N May Ave. Suite 160 Oklahoma City OK 73120-4489	CONTACT NAME: Linda Kirk CISR
	PHONE (A/C No. Ext): (405) 843-0793 FAX (A/C No.): (405) 843-3208 E-MAIL ADDRESS: linda@ticckc.com
INSURED Latchkey Child Services, Inc. 1141 N. Robinson, Ste 404 Oklahoma City OK 73103	INSURER(S) AFFORDING COVERAGE
	INSURER A: Stonington Insurance Co
	INSURER B:
	INSURER C:
	INSURER D:
	INSURER E:

COVERAGES CERTIFICATE NUMBER: 12/13 Master REVISION NUMBER:

THIS IS TO CERTIFY THAT THE POLICIES OF INSURANCE LISTED BELOW HAVE BEEN ISSUED TO THE INSURED NAMED ABOVE FOR THE POLICY PERIOD INDICATED. NOTWITHSTANDING ANY REQUIREMENT, TERM OR CONDITION OF ANY CONTRACT OR OTHER DOCUMENT WITH RESPECT TO WHICH THIS CERTIFICATE MAY BE ISSUED OR MAY PERTAIN, THE INSURANCE AFFORDED BY THE POLICIES DESCRIBED HEREIN IS SUBJECT TO ALL THE TERMS, EXCLUSIONS AND CONDITIONS OF SUCH POLICIES. LIMITS SHOWN MAY HAVE BEEN REDUCED BY PAID CLAIMS.

INSR LTR	TYPE OF INSURANCE	ADDL INSR	SUBR Y/N	POLICY NUMBER	POLICY EFF (MM/DD/YYYY)	POLICY EXP (MM/DD/YYYY)	LIMITS
A	GENERAL LIABILITY <input checked="" type="checkbox"/> COMMERCIAL GENERAL LIABILITY <input type="checkbox"/> CLAIMS-MADE <input checked="" type="checkbox"/> OCCUR			CCP30038025	7/1/2012	7/1/2013	EACH OCCURRENCE \$ 1,000,000 DAMAGE TO RENTED PREMISES (Ea occurrence) \$ 100,000 MED EXP (Any one person) \$ 5,000 PERSONAL & ADV INJURY \$ 1,000,000 GENERAL AGGREGATE \$ 3,000,000 PRODUCTS - COMPROP AGG \$ 3,000,000
	GENL AGGREGATE LIMIT APPLIES PER: <input checked="" type="checkbox"/> POLICY <input type="checkbox"/> PROJECT <input type="checkbox"/> LOC						
A	AUTOMOBILE LIABILITY <input type="checkbox"/> ANY AUTO <input type="checkbox"/> ALL OWNED AUTOS <input type="checkbox"/> HIRED AUTOS			CCP30038025	7/1/2012	7/1/2013	COMBINED SINGLE LIMIT (Ea accident) \$ BODILY INJURY (Per person) \$ BODILY INJURY (Per accident) \$ PROPERTY DAMAGE (Per accident) \$
	<input type="checkbox"/> SCHEDULED AUTOS <input type="checkbox"/> NON-OWNED AUTOS						
	UMBRELLA LIAB <input type="checkbox"/> EXCESS LIAB						EACH OCCURRENCE \$ AGGREGATE \$
	<input type="checkbox"/> OCCUR <input type="checkbox"/> CLAIMS-MADE						
	DED RETENTION \$						
	WORKERS COMPENSATION AND EMPLOYERS' LIABILITY ANY PROPRIETOR/PARTNER/EXECUTIVE OFFICER/MEMBER EXCLUDED? (Mandatory in NH) If yes, describe under DESCRIPTION OF OPERATIONS below		Y/N	N/A			WC STATUTORY LIMITS \$ OTHER \$ E.L. EACH ACCIDENT \$ E.L. DISEASE - EA EMPLOYEE \$ E.L. DISEASE - POLICY LIMIT \$

DESCRIPTION OF OPERATIONS / LOCATIONS / VEHICLES (Attach ACORD 101, Additional Remarks Schedule, if more space is required)

CERTIFICATE HOLDER

Mustang Public Schools
1141 N. Robinson, ste 404
Oklahoma City, OK 73103

CANCELLATION

SHOULD ANY OF THE ABOVE DESCRIBED POLICIES BE CANCELLED BEFORE THE EXPIRATION DATE THEREOF, NOTICE WILL BE DELIVERED IN ACCORDANCE WITH THE POLICY PROVISIONS.

AUTHORIZED REPRESENTATIVE

S.H. Green CPCU/LLA



MUSTANG PUBLIC SCHOOLS

Use of Facility Form

GENERAL INFORMATION

APPLICANT

Organization: Latchkey Child Services, Inc.
 Name of Applicant: Linda L. Cohn
 Address: 1141 N. Robinson Suite 404, OKC, OK 73103
 Billing Address: same Telephone (Work) 405-236-2069
 Contact Person: Linda Cohn Telephone (Home) 405-826-8892

EVENT DETAILS

Name of Activity: Before & After School Program
 Purpose of Activity: Provide supervised activities during out-of-school time
 Date(s)/Day(s) Requested: 2013-2014 school year
 Facility Entry Time 6:30am @ pm 2:30 Facility Exit Time 8:00 am pm 6:30
 Actual Performance (if applicable) Start time n/a am pm End Time n/a am pm
 Expected number of participants 60 Expected number of audience (if applicable) n/a

RESPONSIBILITIES OF THE APPLICANT

- Read the Use of Facilities and Grounds Policy #2030. This policy provides the guidelines that are to be followed.
- Complete this form, 2030C, front and back. A copy of the board approved rental sheet is enclosed for your use in completing this form.
- Read and sign Felony Check and Sex Offender Registry statement (2030D). This form needs to be notarized.
- Provide a certificate of insurance for each request. It is the responsibility of the organization to provide a copy of an updated insurance verification if the certificate expires during the timeframe that the facility and/or grounds have been approved for use.
- I understand that upon completion of the form, it must be returned to the Administrative Assistant's office along with the certificate of insurance and the Felony Checks and Sex Offender Registry form 30 days prior to the regularly scheduled board meeting.
- I understand that expenses for all facilities will be billed following the board meeting at which approval is granted and will be payable upon receipt of invoice. Payment is to be received by MPS before the facility can be used.

INSURANCE REQUIREMENTS

The user shall file a liability insurance policy with the Mustang Board of Education. Limits of liability shall not be less than:

\$100,000.00	Property Damage
\$100,000.00	Personal Injury each accident or occurrence
\$100,000.00	Aggregated (all claims for anyone occurrence)

The policy shall reflect an additional named insured: Mustang Board of Education
 Mustang Public School District I-69
 Mustang, Oklahoma 73064

Current Insurance Verification Provided: Yes No Expires: 7-1-2013

FACILITY REQUESTED (Please refer to Policy # 2030D for the rental fees)

<u>High School</u>	<u>Mid-High</u>	<u>MMS</u>	<u>MNMS</u>
Cafeteria	Cafeteria	Cafeteria	Cafeteria
Kitchen	Kitchen	Kitchen	Kitchen
PE building	Wrestling Room	Wrestling Room	Wrestling Room
Wrestling Room	Gymnasium	Gymnasium	Gymnasium
MHS soccer practice field		Softball field	Softball/baseball field

Elementary Schools (Please select a site)

- Mustang Elementary
- Centennial Elementary
- Lakehoma Elementary
- Trails Elementary
- Creek Elementary
- Valley Elementary

Facility

- Cafeteria
- Kitchen
- Gymnasium
- Playing Field

Total to be invoiced:

(office use only)

Custodial Fees: Custodial fees apply for the use of cafeterias, gymnasiums, wrestling rooms and classrooms. Fees are only charged for Saturday and/or Sunday use with a two (2) hour minimum.

Number of participants: 60 Number of Mustang students participating: 60

Will admission be charged: Yes No

Special Equipment Needed: none

AGREEMENT

We (I), Latchkey Child Services understand that we (I) are (am) to assume all damages to facilities, disappearance of equipment and costs of unauthorized usage.

We (I), assume full liability for the care and the use of the facility and agree not to hold the school district liable for anything arising of our (my) use of the Mustang Public School facility. We (I) certify that no registered sex offenders are working this/these events(s).

We (I) further agree to indemnify and save harmless the Mustang School District and the Mustang Board of Education from and against any and all claims and demands whether for injuries to persons or loss of life, or damage to property occurring within the Mustang Schools facility and arising out of the use and occupancy of said facility by us (me), our (my) employees, guests, members, participants and invitees.

Representative's Signature: [Signature] Date: 5-1-13

OFFICE USE

Estimated Charge for Use of Facility

Rental of Facility: Custodial Costs: Other:

TOTAL COST:

Signatures:

Administrative Assistant: [Signature]

Date: 9-3-13

Athletic Director (If applicable):

Date: Date:

Superintendent of Schools: [Signature]

Date: 9-5-13

President of Mustang Board of Education:

Date:

FELONY CHECKS & SEX OFFENDER REGISTRY

As a representative of the organization that is requesting to use a Mustang Public School facility and/or grounds, this letter is to acknowledge that all the employees/coaches of the organization have clean felony checks and are not listed as sex offenders.

L L Ch _____ 5-1-13
Signature of Representative Date

STATE OF: Oklahoma
COUNTY OF: Oklahoma

Subscribed and sworn to before me this 1st day of May, 2013.

Kathy Sue Day
Signature of Notary Public



SEAL

Adopted: 08-14-06



CERTIFICATE OF LIABILITY INSURANCE

DATE (MM/DD/YYYY)
7/12/2012

THIS CERTIFICATE IS ISSUED AS A MATTER OF INFORMATION ONLY AND CONFERS NO RIGHTS UPON THE CERTIFICATE HOLDER. THIS CERTIFICATE DOES NOT AFFIRMATIVELY OR NEGATIVELY AMEND, EXTEND OR ALTER THE COVERAGE AFFORDED BY THE POLICIES BELOW. THIS CERTIFICATE OF INSURANCE DOES NOT CONSTITUTE A CONTRACT BETWEEN THE ISSUING INSURER(S), AUTHORIZED REPRESENTATIVE OR PRODUCER, AND THE CERTIFICATE HOLDER.

IMPORTANT: If the certificate holder is an ADDITIONAL INSURED, the policy(ies) must be endorsed. If SUBROGATION IS WAIVED, subject to the terms and conditions of the policy, certain policies may require an endorsement. A statement on this certificate does not confer rights to the certificate holder in lieu of such endorsement(s).

PRODUCER The Insurance Center Agency, Inc. 9020 N May Ave. Suite 160 Oklahoma City OK 73120-4489	CONTACT NAME: Linda Kirk CISR
	PHONE (A/C No. Ext.): (405) 843-0793 FAX (A/C No.): (405) 843-3208 E-MAIL ADDRESS: linda@ticokc.com
INSURED Latchkey Child Services, Inc. 1141 N. Robinson, Ste 404 Oklahoma City OK 73103	INSURER(S) AFFORDING COVERAGE
	INSURER A: Stonington Insurance Co
	INSURER B:
	INSURER C:
	INSURER D:
	INSURER E:

COVERAGES CERTIFICATE NUMBER: 12/13 Master REVISION NUMBER:

THIS IS TO CERTIFY THAT THE POLICIES OF INSURANCE LISTED BELOW HAVE BEEN ISSUED TO THE INSURED NAMED ABOVE FOR THE POLICY PERIOD INDICATED. NOTWITHSTANDING ANY REQUIREMENT, TERM OR CONDITION OF ANY CONTRACT OR OTHER DOCUMENT WITH RESPECT TO WHICH THIS CERTIFICATE MAY BE ISSUED OR MAY PERTAIN, THE INSURANCE AFFORDED BY THE POLICIES DESCRIBED HEREIN IS SUBJECT TO ALL THE TERMS, EXCLUSIONS AND CONDITIONS OF SUCH POLICIES. LIMITS SHOWN MAY HAVE BEEN REDUCED BY PAID CLAIMS.

INSR LTR	TYPE OF INSURANCE	ADDL SUBR INSR WVD	POLICY NUMBER	POLICY EFF (MM/DD/YYYY)	POLICY EXP (MM/DD/YYYY)	LIMITS
A	GENERAL LIABILITY		CCP30038025	7/1/2012	7/1/2013	EACH OCCURRENCE \$ 1,000,000
	<input checked="" type="checkbox"/> COMMERCIAL GENERAL LIABILITY					DAMAGE TO RENTED PREMISES (Ea occurrence) \$ 100,000
	<input type="checkbox"/> CLAIMS-MADE <input checked="" type="checkbox"/> OCCUR					MED EXP (Any one person) \$ 5,000
	GENL AGGREGATE LIMIT APPLIES PER:					
	<input checked="" type="checkbox"/> POLICY <input type="checkbox"/> PROJECT <input type="checkbox"/> LOC					GENERAL AGGREGATE \$ 3,000,000
A	AUTOMOBILE LIABILITY		CCP30038025	7/1/2012	7/1/2013	COMBINED SINGLE LIMIT (Ea accident) \$
	<input type="checkbox"/> ANY AUTO	<input type="checkbox"/> SCHEDULED AUTOS				BODILY INJURY (Per person) \$
	<input type="checkbox"/> ALL OWNED AUTOS	<input type="checkbox"/> NON-OWNED AUTOS				BODILY INJURY (Per accident) \$
	<input type="checkbox"/> HIRED AUTOS					PROPERTY DAMAGE (Per accident) \$
	UMBRELLA LIAB <input type="checkbox"/> OCCUR					EACH OCCURRENCE \$
	EXCESS LIAB <input type="checkbox"/> CLAIMS MADE					AGGREGATE \$
	DED <input type="checkbox"/> RETENTIONS					\$
	WORKERS COMPENSATION AND EMPLOYERS' LIABILITY					WC STATUTORY LIMITS <input type="checkbox"/> OTHER <input type="checkbox"/>
	ANY PROPRIETOR/PARTNER/EXECUTIVE OFFICER/MEMBER EXCLUDED? (Mandatory in NH)	<input type="checkbox"/> Y/N	N/A			E.L. EACH ACCIDENT \$
	If yes, describe under DESCRIPTION OF OPERATIONS below					E.L. DISEASE - EA EMPLOYEE \$
						E.L. DISEASE - POLICY LIMIT \$

DESCRIPTION OF OPERATIONS / LOCATIONS / VEHICLES (Attach ACORD 101, Additional Remarks Schedule, if more space is required)

CERTIFICATE HOLDER Mustang Public Schools 1141 N. Robinson, ste 404 Oklahoma City, OK 73103	CANCELLATION SHOULD ANY OF THE ABOVE DESCRIBED POLICIES BE CANCELLED BEFORE THE EXPIRATION DATE THEREOF, NOTICE WILL BE DELIVERED IN ACCORDANCE WITH THE POLICY PROVISIONS.
	AUTHORIZED REPRESENTATIVE S. H. Green CPCU/LIA



MUSTANG PUBLIC SCHOOLS

Use of Facility Form

GENERAL INFORMATION

APPLICANT

Organization: Latchkey Child Services, Inc.
 Name of Applicant: Linda L. Cohn
 Address: 1141 N. Robinson Suite 404, OKC, OK 73103
 Billing Address: same Telephone (Work) 405-236-2069
 Contact Person: Linda Cohn Telephone (Home) 405-826-8892

EVENT DETAILS

Name of Activity: Before & After School Program
 Purpose of Activity: Provide supervised activities during out-of-school time
 Date(s)/Day(s) Requested: 2013-2014 school year
 Facility Entry Time 6:30 am @ pm 2:30 Facility Exit Time 8:00 am @ pm 6:30
 Actual Performance (if applicable) Start time n/a am pm End Time n/a am pm
 Expected number of participants 40 Expected number of audience (if applicable) n/a

RESPONSIBILITIES OF THE APPLICANT

- Read the Use of Facilities and Grounds Policy #2030. This policy provides the guidelines that are to be followed.
- Complete this form, 2030C, front and back. A copy of the board approved rental sheet is enclosed for your use in completing this form.
- Read and sign Felony Check and Sex Offender Registry statement (2030D). This form needs to be notarized.
- Provide a certificate of insurance for each request. It is the responsibility of the organization to provide a copy of an updated insurance verification if the certificate expires during the timeframe that the facility and/or grounds have been approved for use.
- I understand that upon completion of the form, it must be returned to the Administrative Assistant's office along with the certificate of insurance and the Felony Checks and Sex Offender Registry form 30 days prior to the regularly scheduled board meeting.
- I understand that expenses for all facilities will be billed following the board meeting at which approval is granted and will be payable upon receipt of invoice. Payment is to be received by MPS before the facility can be used.

INSURANCE REQUIREMENTS

The user shall file a liability insurance policy with the Mustang Board of Education. Limits of liability shall not be less than:

\$100,000.00	Property Damage
\$100,000.00	Personal Injury each accident or occurrence
\$100,000.00	Aggregated (all claims for anyone occurrence)

The policy shall reflect an additional named insured: Mustang Board of Education
 Mustang Public School District I-69
 Mustang, Oklahoma 73064

Current Insurance Verification Provided: Yes No Expires: 7-1-2013

FACILITY REQUESTED (Please refer to Policy # 2030D for the rental fees)

<u>High School</u>	<u>Mid-High</u>	<u>MMS</u>	<u>MNMS</u>
Cafeteria	Cafeteria	Cafeteria	Cafeteria
Kitchen	Kitchen	Kitchen	Kitchen
PE building	Wrestling Room	Wrestling Room	Wrestling Room
Wrestling Room	Gymnasium	Gymnasium	Gymnasium
MHS soccer practice field		Softball field	Softball/baseball field

Mustang Intermediate (5th + 6th) Cafeteria - (Horizon)

Elementary Schools (Please select a site)

Facility

- Mustang Elementary
- Centennial Elementary
- Lakehoma Elementary
- Trails Elementary
- Creek Elementary
- Valley Elementary

- Cafeteria
- Kitchen
- Gymnasium
- Playing Field

Total to be invoiced:

(office use only)

Custodial Fees: Custodial fees apply for the use of cafeterias, gymnasiums, wrestling rooms and classrooms. Fees are only charged for Saturday and/or Sunday use with a two (2) hour minimum.

Number of participants: 40 Number of Mustang students participating: 40

Will admission be charged: Yes No

Special Equipment Needed: none

AGREEMENT

We (I), Latahkey Child Services understand that we (I) are (am) to assume all damages to facilities, disappearance of equipment and costs of unauthorized usage.

We (I), assume full liability for the care and the use of the facility and agree not to hold the school district liable for anything arising of our (my) use of the Mustang Public School facility. We (I) certify that no registered sex offenders are working this/these event(s).

We (I) further agree to indemnify and save harmless the Mustang School District and the Mustang Board of Education from and against any and all claims and demands whether for injuries to persons or loss of life, or damage to property occurring within the Mustang Schools facility and arising out of the use and occupancy of said facility by us (me), our (my) employees, guests, members, participants and invitees.

Representative's Signature: [Signature] Date: 5-1-13

OFFICE USE

Estimated Charge for Use of Facility

Rental of Facility: _____ Custodial Costs: _____ Other: _____

TOTAL COST: _____

Signatures:

Administrative Assistant: [Signature]

Date: 9-5-13

Athletic Director (If applicable): _____

Date: _____ Date: _____

Superintendent of Schools: [Signature]

Date: 9-5-13

President of Mustang Board of Education: _____

Date: _____

FELONY CHECKS & SEX OFFENDER REGISTRY

As a representative of the organization that is requesting to use a Mustang Public School facility and/or grounds, this letter is to acknowledge that all the employees/coaches of the organization have clean felony checks and are not listed as sex offenders.

[Handwritten Signature] _____ 5-1-13
Signature of Representative Date

STATE OF: Oklahoma
COUNTY OF: Oklahoma

Subscribed and sworn to before me this 1st day of May, 2013.

[Handwritten Signature: Kathy Sue Day]
Signature of Notary Public

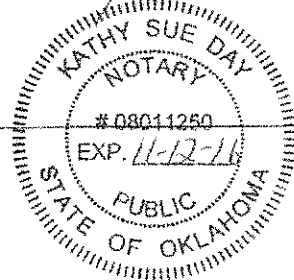

SEAL

Adopted: 08-14-06



CERTIFICATE OF LIABILITY INSURANCE

DATE (MM/DD/YYYY)
7/12/2012

THIS CERTIFICATE IS ISSUED AS A MATTER OF INFORMATION ONLY AND CONFERS NO RIGHTS UPON THE CERTIFICATE HOLDER. THIS CERTIFICATE DOES NOT AFFIRMATIVELY OR NEGATIVELY AMEND, EXTEND OR ALTER THE COVERAGE AFFORDED BY THE POLICIES BELOW. THIS CERTIFICATE OF INSURANCE DOES NOT CONSTITUTE A CONTRACT BETWEEN THE ISSUING INSURER(S), AUTHORIZED REPRESENTATIVE OR PRODUCER, AND THE CERTIFICATE HOLDER.

IMPORTANT: If the certificate holder is an ADDITIONAL INSURED, the policy(ies) must be endorsed. If SUBROGATION IS WAIVED, subject to the terms and conditions of the policy, certain policies may require an endorsement. A statement on this certificate does not confer rights to the certificate holder in lieu of such endorsement(s).

PRODUCER The Insurance Center Agency, Inc. 9020 N May Ave. Suite 160 Oklahoma City OK 73120-4489	CONTACT NAME: Linda Kirk CISR
	PHONE (A/C No. Ext): (405) 843-0793 FAX (A/C No.): (405) 843-3208 E-MAIL ADDRESS: linda@ticokc.com
INSURED Latchkey Child Services, Inc. 1141 N. Robinson, Ste 404 Oklahoma City OK 73103	INSURER(S) AFFORDING COVERAGE
	INSURER A: Stonington Insurance Co
	INSURER B:
	INSURER C:
	INSURER D:
	INSURER E:

COVERAGES CERTIFICATE NUMBER: 12/13 Master REVISION NUMBER:

THIS IS TO CERTIFY THAT THE POLICIES OF INSURANCE LISTED BELOW HAVE BEEN ISSUED TO THE INSURED NAMED ABOVE FOR THE POLICY PERIOD INDICATED. NOTWITHSTANDING ANY REQUIREMENT, TERM OR CONDITION OF ANY CONTRACT OR OTHER DOCUMENT WITH RESPECT TO WHICH THIS CERTIFICATE MAY BE ISSUED OR MAY PERTAIN, THE INSURANCE AFFORDED BY THE POLICIES DESCRIBED HEREIN IS SUBJECT TO ALL THE TERMS, EXCLUSIONS AND CONDITIONS OF SUCH POLICIES. LIMITS SHOWN MAY HAVE BEEN REDUCED BY PAID CLAIMS.

INSR I, TR	TYPE OF INSURANCE	ADDL ISSUR INSR LKWD	POLICY NUMBER	POLICY EFF (MM/DD/YYYY)	POLICY EXP (MM/DD/YYYY)	LIMITS
A	GENERAL LIABILITY <input checked="" type="checkbox"/> COMMERCIAL GENERAL LIABILITY <input type="checkbox"/> CLAIMS-MADE <input checked="" type="checkbox"/> OCCUR		CCP30038025	7/1/2012	7/1/2013	EACH OCCURRENCE \$ 1,000,000 DAMAGE TO RENTED PREMISES (Ea occurrence) \$ 100,000 MED EXP (Any one person) \$ 5,000 PERSONAL & ADV INJURY \$ 1,000,000 GENERAL AGGREGATE \$ 3,000,000 PRODUCTS - COMP/OP AGG \$ 3,000,000
	GENL AGGREGATE LIMIT APPLIES PER: <input checked="" type="checkbox"/> POLICY <input type="checkbox"/> PRO-JECT <input type="checkbox"/> LOC					
A	AUTOMOBILE LIABILITY <input type="checkbox"/> ANY AUTO <input type="checkbox"/> ALL OWNED AUTOS <input type="checkbox"/> HIRED AUTOS <input type="checkbox"/> SCHEDULED AUTOS <input type="checkbox"/> NON-OWNED AUTOS		CCP30038025	7/1/2012	7/1/2013	COMBINED SINGLE LIMIT (Ea accident) \$ BODILY INJURY (Per person) \$ BODILY INJURY (Per accident) \$ PROPERTY DAMAGE (Per accident) \$
	UMBRELLA LIAB <input type="checkbox"/> OCCUR EXCESS LIAB <input type="checkbox"/> CLAIMS-MADE					EACH OCCURRENCE \$ AGGREGATE \$
	WORKERS COMPENSATION AND EMPLOYERS' LIABILITY ANY PROPRIETOR/PARTNER/EXECUTIVE OFFICER/MEMBER EXCLUDED? (Mandatory in NH) If yes, describe under DESCRIPTION OF OPERATIONS below	Y/N <input type="checkbox"/> N/A				WC STATU-TORY LIMITS <input type="checkbox"/> OTH-ER \$ E.L. EACH ACCIDENT \$ E.L. DISEASE - EA EMPLOYEE \$ E.L. DISEASE - POLICY LIMIT \$

DESCRIPTION OF OPERATIONS / LOCATIONS / VEHICLES (Attach ACORD 101, Additional Remarks Schedule, if more space is required)

CERTIFICATE HOLDER Mustang Public Schools 1141 N. Robinson, ste 404 Oklahoma City, OK 73103	CANCELLATION SHOULD ANY OF THE ABOVE DESCRIBED POLICIES BE CANCELLED BEFORE THE EXPIRATION DATE THEREOF, NOTICE WILL BE DELIVERED IN ACCORDANCE WITH THE POLICY PROVISIONS.
	AUTHORIZED REPRESENTATIVE S.H. Green CPCU/LIA

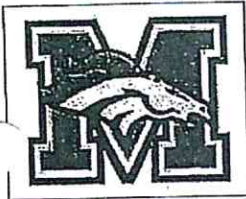

MUSTANG PUBLIC SCHOOLS

Use of Facility Form

GENERAL INFORMATION

APPLICANT

Organization: Latchkey Child Services, Inc.
 Name of Applicant: Linda L. Cohn
 Address: 1141 N. Robinson Suite 404, OKC, OK 73103
 Billing Address: same Telephone (Work) 405-236-2069
 Contact Person: Linda Cohn Telephone (Home) 405-826-8892

EVENT DETAILS

Name of Activity: Before & After School Program
 Purpose of Activity: Provide supervised activities during out-of-school time
 Date(s)/Day(s) Requested: 2013-2014 school year
 Facility Entry Time 6:30am @ pm 2:30 Facility Exit Time 8:00 @ am @ pm 6:30
 Actual Performance (if applicable) Start time n/a am pm End Time n/a am pm
 Expected number of participants 40 Expected number of audience (if applicable) n/a

RESPONSIBILITIES OF THE APPLICANT

- Read the Use of Facilities and Grounds Policy #2030. This policy provides the guidelines that are to be followed.
- Complete this form, 2030C, front and back. A copy of the board approved rental sheet is enclosed for your use in completing this form.
- Read and sign Felony Check and Sex Offender Registry statement (2030D). This form needs to be notarized.
- Provide a certificate of insurance for each request. It is the responsibility of the organization to provide a copy of an updated insurance verification if the certificate expires during the timeframe that the facility and/or grounds have been approved for use.
- Understand that upon completion of the form, it must be returned to the Administrative Assistant's office along with the certificate of insurance and the Felony Checks and Sex Offender Registry form 30 days prior to the regularly scheduled board meeting.
- Understand that expenses for all facilities will be billed following the board meeting at which approval is granted and will be payable upon receipt of invoice. Payment is to be received by MPS before the facility can be used.

INSURANCE REQUIREMENTS

The user shall file a liability insurance policy with the Mustang Board of Education. Limits of liability shall not be less than:

\$100,000.00	Property Damage
\$100,000.00	Personal Injury each accident or occurrence
\$100,000.00	Aggregated (all claims for anyone occurrence)

The policy shall reflect an additional named insured: Mustang Board of Education
 Mustang Public School District I-69
 Mustang, Oklahoma 73064

Current Insurance Verification Provided: Yes No Expires: 7-1-2013

FACILITY REQUESTED (Please refer to Policy # 2030D for the rental fees)

<u>High School</u>	<u>Mid-High</u>	<u>MMS</u>	<u>MNMS</u>
Cafeteria	Cafeteria	Cafeteria	Cafeteria
Kitchen	Kitchen	Kitchen	Kitchen
PE building	Wrestling Room	Wrestling Room	Wrestling Room
Wrestling Room	Gymnasium	Gymnasium	Gymnasium
MHS soccer practice field		Softball field	Softball/baseball field

X Mustang Intermediate (\$4^{hr} x 6^{hr}) Cafeteria (?)

Elementary Schools (Please select a site)

Facility

Mustang Elementary	X Cafeteria
Centennial Elementary	Kitchen
Lakehoma Elementary	Gymnasium
Trails Elementary	Playing Field
Creek Elementary	
Valley Elementary	

Total to be invoiced:

(office use only)

Custodial Fees: Custodial fees apply for the use of cafeterias, gymnasiums, wrestling rooms and classrooms. Fees are only charged for Saturday and/or Sunday use with a two (2) hour minimum.

Number of participants: 40 Number of Mustang students participating: 40

Will admission be charged: Yes No

Special Equipment Needed: none

AGREEMENT

We (I), Latchkey Child Services understand that we (I) are (am) to assume all damages to facilities, disappearance of equipment and costs of unauthorized usage.

We (I), assume full liability for the care and the use of the facility and agree not to hold the school district liable for anything arising of our (my) use of the Mustang Public School facility. We (I) certify that no registered sex offenders are working this/these event(s).

We (I) further agree to indemnify and save harmless the Mustang School District and the Mustang Board of Education from and against any and all claims and demands whether for injuries to persons or loss of life, or damage to property occurring within the Mustang Schools facility and arising out of the use and occupancy of said facility by us (me), our (my) employees, guests, members, participants and invitees.

Representative's Signature: [Signature] Date: 5-1-13

OFFICE USE

Estimated Charge for Use of Facility

Rental of Facility: Custodial Costs: Other:

TOTAL COST:

Signatures:

Administrative Assistant:

Date:

Athletic Director (If applicable):

Date:

Date:

Superintendent of Schools: [Signature]

Date: 9-5-13

President of Mustang Board of Education:

Date:

FELONY CHECKS & SEX OFFENDER REGISTRY

As a representative of the organization that is requesting to use a Mustang Public School facility and/or grounds, this letter is to acknowledge that all the employees/coaches of the organization have clean felony checks and are not listed as sex offenders.

[Handwritten Signature] _____ 5-1-13
Signature of Representative Date

STATE OF: Oklahoma

COUNTY OF: Oklahoma

Subscribed and sworn to before me this 1st day of May, 2013.

[Handwritten Signature: Kathy Sue Day]
Signature of Notary Public

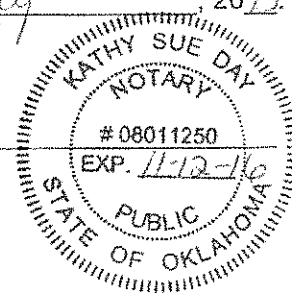

SEAL

Adopted: 08-14-06



CERTIFICATE OF LIABILITY INSURANCE

DATE (MM/DD/YYYY)
7/12/2012

THIS CERTIFICATE IS ISSUED AS A MATTER OF INFORMATION ONLY AND CONFERS NO RIGHTS UPON THE CERTIFICATE HOLDER. THIS CERTIFICATE DOES NOT AFFIRMATIVELY OR NEGATIVELY AMEND, EXTEND OR ALTER THE COVERAGE AFFORDED BY THE POLICIES BELOW. THIS CERTIFICATE OF INSURANCE DOES NOT CONSTITUTE A CONTRACT BETWEEN THE ISSUING INSURER(S), AUTHORIZED REPRESENTATIVE OR PRODUCER, AND THE CERTIFICATE HOLDER.

IMPORTANT: If the certificate holder is an ADDITIONAL INSURED, the policy(ies) must be endorsed. If SUBROGATION IS WAIVED, subject to the terms and conditions of the policy, certain policies may require an endorsement. A statement on this certificate does not confer rights to the certificate holder in lieu of such endorsement(s).

PRODUCER The Insurance Center Agency, Inc. 9020 N May Ave. Suite 160 Oklahoma City OK 73120-4489		CONTACT NAME: Linda Kirk CISR PHONE (A/C No. Ext): (405) 843-0793 FAX (A/C No.): (405) 843-3208 E-MAIL ADDRESS: linda@ticokc.com	
INSURED Latchkey Child Services, Inc. 1141 N. Robinson, Ste 404 Oklahoma City OK 73103		INSURER(S) AFFORDING COVERAGE INSURER A: Stonington Insurance Co INSURER B: INSURER C: INSURER D: INSURER E: INSURER F:	

COVERAGES CERTIFICATE NUMBER: 12/13 Master REVISION NUMBER:

THIS IS TO CERTIFY THAT THE POLICIES OF INSURANCE LISTED BELOW HAVE BEEN ISSUED TO THE INSURED NAMED ABOVE FOR THE POLICY PERIOD INDICATED. NOTWITHSTANDING ANY REQUIREMENT, TERM OR CONDITION OF ANY CONTRACT OR OTHER DOCUMENT WITH RESPECT TO WHICH THIS CERTIFICATE MAY BE ISSUED OR MAY PERTAIN, THE INSURANCE AFFORDED BY THE POLICIES DESCRIBED HEREIN IS SUBJECT TO ALL THE TERMS, EXCLUSIONS AND CONDITIONS OF SUCH POLICIES. LIMITS SHOWN MAY HAVE BEEN REDUCED BY PAID CLAIMS.

INSR LTR	TYPE OF INSURANCE	ADDL SUBR INSR W/VO	POLICY NUMBER	POLICY EFF (MM/DD/YYYY)	POLICY EXP (MM/DD/YYYY)	LIMITS
A	GENERAL LIABILITY <input checked="" type="checkbox"/> COMMERCIAL GENERAL LIABILITY <input type="checkbox"/> CLAIMS-MADE <input checked="" type="checkbox"/> OCCUR		CCP30038025	7/1/2012	7/1/2013	EACH OCCURRENCE \$ 1,000,000 DAMAGE TO RENTED PREMISES (Ea occurrence) \$ 100,000 MED EXP (Any one person) \$ 5,000 PERSONAL & ADV INJURY \$ 1,000,000 GENERAL AGGREGATE \$ 3,000,000 PRODUCTS - COMP/CP AGG \$ 3,000,000
	GENL AGGREGATE LIMIT APPLIES PER: <input checked="" type="checkbox"/> POLICY <input type="checkbox"/> PRO-JECT <input type="checkbox"/> LOC					
A	AUTOMOBILE LIABILITY <input type="checkbox"/> ANY AUTO <input type="checkbox"/> ALL OWNED AUTOS <input type="checkbox"/> HIRED AUTOS <input type="checkbox"/> SCHEDULED AUTOS <input type="checkbox"/> NON OWNED AUTOS		CCP30038025	7/1/2012	7/1/2013	COMBINED SINGLE LIMIT (Ea accident) \$ BODILY INJURY (Per person) \$ BODILY INJURY (Per accident) \$ PROPERTY DAMAGE (Per accident) \$
	UMBRELLA LIAB <input type="checkbox"/> OCCUR EXCESS LIAB <input type="checkbox"/> CLAIMS-MADE DED <input type="checkbox"/> RETENTIONS					
	WORKERS COMPENSATION AND EMPLOYERS' LIABILITY ANY PROPRIETOR/PARTNER/EXECUTIVE OFFICER/MEMBER EXCLUDED? (Mandatory in NH) If yes, describe under DESCRIPTION OF OPERATIONS below	Y/N	N/A			WC STATUTORY LIMITS <input type="checkbox"/> OTHER <input type="checkbox"/> E.L. EACH ACCIDENT \$ E.L. DISEASE - EA EMPLOYEE \$ E.L. DISEASE - POLICY LIMIT \$

DESCRIPTION OF OPERATIONS / LOCATIONS / VEHICLES (Attach ACORD 101, Additional Remarks Schedule, if more space is required)

CERTIFICATE HOLDER Mustang Public Schools 1141 N. Robinson, ste 404 Oklahoma City, OK 73103	CANCELLATION SHOULD ANY OF THE ABOVE DESCRIBED POLICIES BE CANCELLED BEFORE THE EXPIRATION DATE THEREOF, NOTICE WILL BE DELIVERED IN ACCORDANCE WITH THE POLICY PROVISIONS.
	AUTHORIZED REPRESENTATIVE S.H. Green CPCU/LIA



MUSTANG PUBLIC SCHOOLS

Use of Facility Form

GENERAL INFORMATION**APPLICANT**

Organization: *Lakehoma Centennial Afterschool Program*
 Name of Applicant: *Vickie Hadlock*
 Address: *543 E. Hwy 152 Ste. 101 Mustang, OK 73064*
 Billing Address: *Same* Telephone (Work) *376-7377*
 Contact Person: *Vickie Hadlock* Telephone (Home) *376-4374*

EVENT DETAILS

Name of Activity: *Before and after school child care*
 Purpose of Activity: *Provide child care before & afterschool for parents*
 Date(s)/Day(s) Requested: *all days school is in session for students*
 Facility Entry Time: am pm *6:30 am* Facility Exit Time: am pm *7:30 am, 6:30 pm*
 Actual Performance (if applicable) Start time: am pm End Time: am pm
 Expected number of participants *50* Expected number of audience (if applicable)

RESPONSIBILITIES OF THE APPLICANT

- Read the Use of Facilities and Grounds" Policy #2030. This policy provides the guidelines that are to be followed.
- Complete this form, 2030C, front and back. A copy of the board approved rental sheet is enclosed for your use in completing this form.
- Read and sign Felony Check and Sex Offender Registry statement (2030D). This form needs to be notarized.
- Provide a certificate of insurance for each request. It is the responsibility of the organization to provide a copy of an updated insurance verification if the certificate expires during the timeframe that the facility and/or grounds have been approved for use.
- I understand that upon completion of the form, it must be returned to the Administrative Assistant's office along with the certificate of insurance and the Felony Checks and Sex Offender Registry form 30 days prior to the regularly scheduled board meeting.
- I understand that ~~expenses for all facilities will be billed following the board meeting at which approval is granted and will be payable upon receipt of invoice.~~ Payment is to be received by MPS before the facility can be used. *Arrangements made for monthly payments w/ administration*

INSURANCE REQUIREMENTS

The user shall file a liability insurance policy with the Mustang Board of Education. Limits of liability shall not be less than:

\$100,000.00	Property Damage
\$100,000.00	Personal Injury each accident or occurrence
\$100,000.00	Aggregated (all claims for anyone occurrence)

The policy shall reflect an additional named insured: Mustang Board of Education
 Mustang Public School District I-69
 Mustang, Oklahoma 73064

Current Insurance Verification Provided: Yes No Expires:

FACILITY REQUESTED (Please refer to Policy # 2030D for the rental fees)

High School

- Cafeteria
- Kitchen
- PE building
- Wrestling Room
- MHS soccer practice field

Mid-High

- Cafeteria
- Kitchen
- Wrestling Room
- Gymnasium

MMS

- Cafeteria
- Kitchen
- Wrestling Room
- Gymnasium
- Softball field

MNMS

- Cafeteria
- Kitchen
- Wrestling Room
- Gymnasium
- Softball/baseball field

Elementary Schools (Please select a site)

- Mustang Elementary
- Centennial Elementary
- Lakehoma Elementary
- Trails Elementary
- Creek Elementary
- Valley Elementary

Facility

- Cafeteria
- Kitchen
- Gymnasium
- Playing Field

Total to be invoiced:

(office use only)

Custodial Fees: Custodial fees apply for the use of cafeterias, gymnasiums, wrestling rooms and classrooms. Fees are only charged for Saturday and/or Sunday use with a two (2) hour minimum.

Number of participants: 50 Number of Mustang students participating: 50

Will admission be charged: Yes No

Special Equipment Needed:

AGREEMENT

We (I), Vickie Hadlock understand that we (I) are (am) to assume all damages to facilities, disappearance of equipment and costs of unauthorized usage.

We (I), assume full liability for the care and the use of the facility and agree not to hold the school district liable for anything arising of our (my) use of the Mustang Public School facility. We (I) certify that no registered sex offenders are working this/these events(s).

We (I) further agree to indemnify and save harmless the Mustang School District and the Mustang Board of Education from and against any and all claims and demands whether for injuries to persons or loss of life, or damage to property occurring within the Mustang Schools facility and arising out of the use and occupancy of said facility by us (me), our (my) employees, guests, members, participants and invitees.

Representative's Signature: Vickie Hadlock Date: 4/9/13

OFFICE USE

Estimated Charge for Use of Facility

Rental of Facility: Custodial Costs: Other:

TOTAL COST:

Signatures:

Administrative Assistant: [Signature]

Athletic Director(If applicable):

Superintendent of Schools:

President of Mustang Board of Education:

Date: 9-3-13

Date:

Date:

Date:

FELONY CHECKS & SEX OFFENDER REGISTRY

As a representative of the organization that is requesting to use a Mustang Public School facility and/or grounds, this letter is to acknowledge that all the employees/coaches of the organization have clean felony checks and are not listed as sex offenders.

Yickie Hadlock 4-16-13
Signature of Representative Date

STATE OF: OKLAHOMA
COUNTY OF: CANADIAN

Subscribed and sworn to before me this 16th day of April, 2013.

Elaine Arnold
Signature of Notary Public
Comm # 03001797
Exp: 2-6-15

SEAL



Adopted: 08-14-06



CERTIFICATE OF LIABILITY INSURANCE

DATE (MM/DD/YYYY)
11/27/2012

THIS CERTIFICATE IS ISSUED AS A MATTER OF INFORMATION ONLY AND CONFERS NO RIGHTS UPON THE CERTIFICATE HOLDER. THIS CERTIFICATE DOES NOT AFFIRMATIVELY OR NEGATIVELY AMEND, EXTEND OR ALTER THE COVERAGE AFFORDED BY THE POLICIES BELOW. THIS CERTIFICATE OF INSURANCE DOES NOT CONSTITUTE A CONTRACT BETWEEN THE ISSUING INSURER(S), AUTHORIZED REPRESENTATIVE OR PRODUCER, AND THE CERTIFICATE HOLDER.

IMPORTANT: If the certificate holder is an ADDITIONAL INSURED, the policy(ies) must be endorsed. If SUBROGATION IS WAIVED, subject to the terms and conditions of the policy, certain policies may require an endorsement. A statement on this certificate does not confer rights to the certificate holder in lieu of such endorsement(s).

PRODUCER Fulton Insurance Agency Inc 877 S Mustang Rd Yukon, OK 73099		CONTACT NAME: Pam Carter PHONE (A/C, No. Ext): (405)324-1115 E-MAIL ADDRESS: fultoninsurance@hotmail.com FAX (A/C, No.): (405)324-1116	
INSURED Centennial After School Program, Inc 700 South Czech Hall Rd Mustang, OK 73064		INSURER(S) AFFORDING COVERAGE INSURER A: United States Liability Insurance Company INSURER B: INSURER C: INSURER D: INSURER E: INSURER F:	

COVERAGES **CERTIFICATE NUMBER:** **REVISION NUMBER:**

THIS IS TO CERTIFY THAT THE POLICIES OF INSURANCE LISTED BELOW HAVE BEEN ISSUED TO THE INSURED NAMED ABOVE FOR THE POLICY PERIOD INDICATED. NOTWITHSTANDING ANY REQUIREMENT, TERM OR CONDITION OF ANY CONTRACT OR OTHER DOCUMENT WITH RESPECT TO WHICH THIS CERTIFICATE MAY BE ISSUED OR MAY PERTAIN, THE INSURANCE AFFORDED BY THE POLICIES DESCRIBED HEREIN IS SUBJECT TO ALL THE TERMS, EXCLUSIONS AND CONDITIONS OF SUCH POLICIES. LIMITS SHOWN MAY HAVE BEEN REDUCED BY PAID CLAIMS.

INSR LTR	TYPE OF INSURANCE	ADDL ISDR		POLICY NUMBER	POLICY EFF (MM/DD/YYYY)	POLICY EXP (MM/DD/YYYY)	LIMITS	
		INSR	WORD					
A	GENERAL LIABILITY <input checked="" type="checkbox"/> COMMERCIAL GENERAL LIABILITY <input type="checkbox"/> CLAIMS-MADE <input checked="" type="checkbox"/> OCCUR	N	N	CL1587311	11/23/2012	11/23/2013	EACH OCCURRENCE	\$ 1,000,000
	GENL AGGREGATE LIMIT APPLIES PER: <input type="checkbox"/> POLICY <input type="checkbox"/> PRO-JECT <input type="checkbox"/> LOC							DAMAGE TO RENTED PREMISES (Ea occurrence)
	AUTOMOBILE LIABILITY <input type="checkbox"/> ANY AUTO <input type="checkbox"/> ALL OWNED AUTOS <input type="checkbox"/> HIRED AUTOS <input type="checkbox"/> SCHEDULED AUTOS <input type="checkbox"/> NON-OWNED AUTOS						MED EXP (Any one person)	\$ 5,000
	UMBRELLA LIAB EXCESS LIAB DED RETENTION \$ OCCUR CLAIMS-MADE						PERSONAL & ADV INJURY	\$ 1,000,000
	WORKERS COMPENSATION AND EMPLOYERS' LIABILITY ANY PROPRIETOR/PARTNER/EXECUTIVE OFFICER/MEMBER EXCLUDED? (Mandatory in WA) If yes, describe under DESCRIPTION OF OPERATIONS below	Y/N	N/A				GENERAL AGGREGATE	\$ 2,000,000
	DESCRIPTION OF OPERATIONS / LOCATIONS / VEHICLES (Attach ACORD 101, Additional Remarks Schedule, if more space is required)						PRODUCTS - COMP/OP AGG	\$ Included
							Professional Liability	\$ Included
							COMBINED SINGLE LIMIT (Ea accident)	\$
							BODILY INJURY (Per person)	\$
							BODILY INJURY (Per accident)	\$
							PROPERTY DAMAGE (Per accident)	\$
							EACH OCCURRENCE	\$
							AGGREGATE	\$
							WC STATU-TORY LIMITS	
							OTH-ER	
							E.L. EACH ACCIDENT	\$
							E.L. DISEASE - EA EMPLOYEE	\$
							E.L. DISEASE - POLICY LIMIT	\$

CERTIFICATE HOLDER Centennial School 700 S Czech Hall Rd Mustang, OK 73064	CANCELLATION SHOULD ANY OF THE ABOVE DESCRIBED POLICIES BE CANCELLED BEFORE THE EXPIRATION DATE THEREOF, NOTICE WILL BE DELIVERED IN ACCORDANCE WITH THE POLICY PROVISIONS. AUTHORIZED REPRESENTATIVE Chad R Fulton
--	---

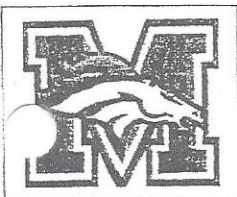

MUSTANG PUBLIC SCHOOLS

Use of Facility Form

GENERAL INFORMATION

APPLICANT

Organization: *Lakehoma Centennial Afterschool Program*
 Name of Applicant: *Vickie Hadlock*
 Address: *543 E. Hwy 152 Ste. 101 Mustang, OK 73064*
 Billing Address: *Same* Telephone (Work) *376-7377*
 Contact Person: *Vickie Hadlock* Telephone (Home) *376-4376*

EVENT DETAILS

Name of Activity: *Before and after school child care*
 Purpose of Activity: *Provide child care before & afterschool for parents*
 Date(s)/Day(s) Requested: *all days school is in session for students*
 Facility Entry Time: am pm *6:30 am* Facility Exit Time: am pm *7:30 am, 6:30 pm*
 Actual Performance (if applicable) Start time: am pm End Time: am pm
 Expected number of participants *50* Expected number of audience (if applicable)

RESPONSIBILITIES OF THE APPLICANT

- Read the Use of Facilities and Grounds Policy #2030. This policy provides the guidelines that are to be followed.
- Complete this form, 2030C, front and back. A copy of the board approved rental sheet is enclosed for your use in completing this form.
- Read and sign Felony Check and Sex Offender Registry statement (2030D). This form needs to be notarized.
- Provide a certificate of insurance for each request. It is the responsibility of the organization to provide a copy of an updated insurance verification if the certificate expires during the timeframe that the facility and/or grounds have been approved for use.
- I understand that upon completion of the form, it must be returned to the Administrative Assistant's office along with the certificate of insurance and the Felony Checks and Sex Offender Registry form 30 days prior to the regularly scheduled board meeting.
- I understand that ~~expenses for all facilities will be billed following the board meeting at which approval is granted and will be payable upon receipt of invoice.~~ Payment is to be received by MPS before the facility can be used. *Arrangements made for monthly payments w/ administration*

INSURANCE REQUIREMENTS

The user shall file a liability insurance policy with the Mustang Board of Education. Limits of liability shall not be less than:

\$100,000.00	Property Damage
\$100,000.00	Personal Injury each accident or occurrence
\$100,000.00	Aggregated (all claims for anyone occurrence)

The policy shall reflect an additional named insured: Mustang Board of Education
 Mustang Public School District I-69
 Mustang, Oklahoma 73064

Current Insurance Verification Provided: Yes No Expires:

FACILITY REQUESTED (Please refer to Policy # 2030D for the rental fees)

High School

- Cafeteria
- Kitchen
- PE building
- Wrestling Room
- MHS soccer practice field

Mid-High

- Cafeteria
- Kitchen
- Wrestling Room
- Gymnasium

MMS

- Cafeteria
- Kitchen
- Wrestling Room
- Gymnasium
- Softball field

MNMS

- Cafeteria
- Kitchen
- Wrestling Room
- Gymnasium
- Softball/baseball field

Elementary Schools (Please select a site)

- Mustang Elementary
- Centennial Elementary
- Lakehoma Elementary
- Trails Elementary
- Creek Elementary
- Valley Elementary

Facility

- Cafeteria
- Kitchen
- Gymnasium
- Playing Field

Total to be invoiced:

(office use only)

Custodial Fees: Custodial fees apply for the use of cafeterias, gymnasiums, wrestling rooms and classrooms. Fees are only charged for Saturday and/or Sunday use with a two (2) hour minimum.

Number of participants: 50 Number of Mustang students participating: 50

Will admission be charged: Yes No

Special Equipment Needed:

AGREEMENT

We (I), Vickie Hadlock understand that we (I) are (am) to assume all damages to facilities, disappearance of equipment and costs of unauthorized usage.

We (I), assume full liability for the care and the use of the facility and agree not to hold the school district liable for anything arising of our (my) use of the Mustang Public School facility. We (I) certify that no registered sex offenders are working this/these events(s).

We (I) further agree to indemnify and save harmless the Mustang School District and the Mustang Board of Education from and against any and all claims and demands whether for injuries to persons or loss of life, or damage to property occurring within the Mustang Schools facility and arising out of the use and occupancy of said facility by us (me), our (my) employees, guests, members, participants and invitees.

Representative's Signature: Vickie Hadlock Date: 4/9/13

OFFICE USE

Estimated Charge for Use of Facility

Rental of Facility: Custodial Costs: Other:

TOTAL COST:

Signatures:

Administrative Assistant: [Signature]

Date: 9-3-13

Athletic Director(If applicable):

Date:

Superintendent of Schools:

Date:

President of Mustang Board of Education:

Date:

CC Assistant Treasurer
 Representative's Address
 Custodial Supervisor
 Child Nutrition
 District Athletic Department

Adopted December 1998
 Revised June 2003
 Revised July 2006
 Revised June 2010

FELONY CHECKS & SEX OFFENDER REGISTRY

As a representative of the organization that is requesting to use a Mustang Public School facility and/or grounds, this letter is to acknowledge that all the employees/coaches of the organization have clean felony checks and are not listed as sex offenders.

Tuckie Hadlock
Signature of Representative

4-14-13
Date

STATE OF: OKLAHOMA
COUNTY OF: CANADIAN

Subscribed and sworn to before me this 16 day of April, 2013.

Elaine Arnold
Signature of Notary Public
Comm # 03001797
Exp: 2-6-15

SEAL



Adopted: 08-14-06



CERTIFICATE OF LIABILITY INSURANCE

DATE (MM/DD/YYYY)
11/27/2012

THIS CERTIFICATE IS ISSUED AS A MATTER OF INFORMATION ONLY AND CONFERS NO RIGHTS UPON THE CERTIFICATE HOLDER. THIS CERTIFICATE DOES NOT AFFIRMATIVELY OR NEGATIVELY AMEND, EXTEND OR ALTER THE COVERAGE AFFORDED BY THE POLICIES BELOW. THIS CERTIFICATE OF INSURANCE DOES NOT CONSTITUTE A CONTRACT BETWEEN THE ISSUING INSURER(S), AUTHORIZED REPRESENTATIVE OR PRODUCER, AND THE CERTIFICATE HOLDER.

IMPORTANT: If the certificate holder is an ADDITIONAL INSURED, the policy(ies) must be endorsed. If SUBROGATION IS WAIVED, subject to the terms and conditions of the policy, certain policies may require an endorsement. A statement on this certificate does not confer rights to the certificate holder in lieu of such endorsement(s).

PRODUCER Fulton Insurance Agency Inc 877 S Mustang Rd Yukon, OK 73099		CONTACT NAME: Pam Carter PHONE (A/C, No, Ext): (405)324-1115 FAX (A/C, No): (405)324-1116 E-MAIL ADDRESS: fultoninsurance@hotmail.com	
INSURED Lahoma After School Program, Inc 224 South Clear Springs Road Mustang, OK 73064		INSURER(S) AFFORDING COVERAGE INSURER A: United States Liability Insurance Company INSURER B: INSURER C: INSURER D: INSURER E: INSURER F:	

COVERAGES **CERTIFICATE NUMBER:** **REVISION NUMBER:**

THIS IS TO CERTIFY THAT THE POLICIES OF INSURANCE LISTED BELOW HAVE BEEN ISSUED TO THE INSURED NAMED ABOVE FOR THE POLICY PERIOD INDICATED. NOTWITHSTANDING ANY REQUIREMENT, TERM OR CONDITION OF ANY CONTRACT OR OTHER DOCUMENT WITH RESPECT TO WHICH THIS CERTIFICATE MAY BE ISSUED OR MAY PERTAIN, THE INSURANCE AFFORDED BY THE POLICIES DESCRIBED HEREIN IS SUBJECT TO ALL THE TERMS, EXCLUSIONS AND CONDITIONS OF SUCH POLICIES. LIMITS SHOWN MAY HAVE BEEN REDUCED BY PAID CLAIMS.

INBR LTR	TYPE OF INSURANCE	ADDL SUBR (INBR) (W/D)	POLICY NUMBER	POLICY EFF (MM/DD/YYYY)	POLICY EXP (MM/DD/YYYY)	LIMITS
A	GENERAL LIABILITY <input checked="" type="checkbox"/> COMMERCIAL GENERAL LIABILITY CLAIMS-MADE <input checked="" type="checkbox"/> OCCUR GEN'L AGGREGATE LIMIT APPLIES PER: <input type="checkbox"/> POLICY <input type="checkbox"/> PRO-JECT <input type="checkbox"/> LOC	N N	CL1587253	11/23/2012	11/23/2013	EACH OCCURRENCE \$ 1,000,000 DAMAGE TO RENTED PREMISES (Ea occurrence) \$ 100,000 MED EXP (Any one person) \$ 5,000 PERSONAL & ADV INJURY \$ 1,000,000 GENERAL AGGREGATE \$ 2,000,000 PRODUCTS - COMP/OP AGG \$ Included Professional Liability \$ Included COMBINED SINGLE LIMIT (Ea accident) \$ BODILY INJURY (Per person) \$ BODILY INJURY (Per accident) \$ PROPERTY DAMAGE (Per accident) \$ EACH OCCURRENCE \$ AGGREGATE \$
	AUTOMOBILE LIABILITY <input type="checkbox"/> ANY AUTO <input type="checkbox"/> ALL OWNED AUTOS <input type="checkbox"/> HIRED AUTOS <input type="checkbox"/> SCHEDULED AUTOS <input type="checkbox"/> NON-OWNED AUTOS					BODILY INJURY (Per person) \$ BODILY INJURY (Per accident) \$ PROPERTY DAMAGE (Per accident) \$ EACH OCCURRENCE \$ AGGREGATE \$
	UMBRELLA LIAB EXCESS LIAB DED RETENTION \$	<input type="checkbox"/> OCCUR <input type="checkbox"/> CLAIMS-MADE				EACH OCCURRENCE \$ AGGREGATE \$
	WORKERS COMPENSATION AND EMPLOYERS' LIABILITY ANY PROPRIETOR/PARTNER/EXECUTIVE OFFICE/MEMBER EXCLUDED? (Mandatory in NH) If yes, describe under DESCRIPTION OF OPERATIONS below	Y/N	N/A			WC STATU-TORY LIMITS OTH-ER E.L. EACH ACCIDENT \$ E.L. DISEASE - EA EMPLOYEE \$ E.L. DISEASE - POLICY LIMIT \$

DESCRIPTION OF OPERATIONS / LOCATIONS / VEHICLES (Attach ACORD 101, Additional Remarks Schedule, if more space is required)

CERTIFICATE HOLDER Lahoma School 224 South Clear Springs Road Mustang, OK 73064	CANCELLATION SHOULD ANY OF THE ABOVE DESCRIBED POLICIES BE CANCELLED BEFORE THE EXPIRATION DATE THEREOF, NOTICE WILL BE DELIVERED IN ACCORDANCE WITH THE POLICY PROVISIONS. AUTHORIZED REPRESENTATIVE Chad R Fulton
---	---



MUSTANG PUBLIC SCHOOLS

Use of Facility Form

GENERAL INFORMATION

APPLICANT:

Organization: Oklahoma Mustangs
 Name of Applicant: Gerry Hunt
 Billing Address: 522 N Canadian Terr, Mustang, OK 73064
 E-mail Address: ghunt@okcu.edu Telephone (Cell) 405-413-5582
 Contact Person: Gerry Hunt Telephone (Other) 405-208-5582

EVENT DETAILS:

Name of Activity: Basketball Practice
 Purpose of Activity: Provide instruction and develop skills of young boys & girls basketball players
 Date(s)/Day(s) Requested: Sundays from 2-3pm starting Sept 15-Oct 27, Tue/Thur from 6-8:30pm starting Nov 5th -> Feb 27th
 Facility Entry Time: 6:30 am pm Facility Exit Time: 8:00 am pm
 Actual Performance (if applicable) Start Time: _____ am pm End Time: _____ am pm
 Expected number of participants: 24 Expected number of audience (if applicable): _____

RESPONSIBILITIES OF THE APPLICANT:

- Read the Use of Facilities and Grounds' Policy #2030. This policy provides the guidelines that are to be followed.
- Complete this form, 2030C. A copy of the board approved rental sheet is enclosed for your use in completing this form.
- Read and sign Felony Check and Sex Offender Registry statement (2030D). This form needs to be notarized.
- Provide a **certificate of insurance** for each request. It is the responsibility of the organization to provide a copy of an updated insurance verification if the certificate expires during the timeframe that the facility and/or grounds have been approved for use.
- I understand that upon completion of the request form, it must be returned to the MPS Administration Building Secretary along with the certificate of insurance and the Felony Checks and Sex Offender Registry form **30 days prior to the regularly scheduled board meeting**.
- Pending board approval, I understand that expenses for all facility usage will be billed following completion of the event and will be **payable upon receipt of invoice**. **Failure to promptly settle financial obligations will void future facility usage requests.**

INSURANCE REQUIREMENTS:

The user shall file a liability insurance policy with the Mustang Board of Education. Limits of liability shall not be less than:

\$100,000.00	Property Damage
\$100,000.00	Personal Injury each accident or occurrence
\$100,000.00	Aggregated (all claims for anyone occurrence)

The policy shall reflect an additional named insured: **Mustang Board of Education**
Mustang Public School District I-69
Mustang, Oklahoma 73064

Current Insurance Verification Provided: Yes No Expires:

* will be purchased upon approval and prior to any usage.

FACILITY REQUESTED (Please refer to Policy # 2030A for the rental fees)

High School

Cafeteria
Kitchen
Commons area
Wrestling Room
MHS soccer practice field
Classrooms

MMS

Cafeteria
Kitchen
Wrestling Room
Gymnasium
Softball field
Classrooms

MNMS

Cafeteria
Kitchen
Commons Gym
Gymnasium
Softball/baseball field
Classrooms

Horizon Intermediate

Main Gym Only

Elementary Schools (Please select a site)

Mustang Elementary
Centennial Elementary
Lakehoma Elementary
Trails Elementary
Creek Elementary
Valley Elementary

Facility

Cafeteria
Kitchen
Gymnasium
Playing Field
Classrooms

Total to be invoiced:

(office use only)

Custodial Fees: Custodial fees apply for the use of cafeterias, gymnasiums, wrestling rooms and classrooms. Fees are only charged for Saturday and/or Sunday use with a two (2) hour minimum.

Number of participants: 24 Number of Mustang students participating: 24

Will admission be charged: Yes No

Special Equipment Needed: None. Basketball goals in place.

AGREEMENT:

- We (I), Gerry Hunt understand that we (I) are (am) to assume all damages to facilities, disappearance of equipment and costs of unauthorized usage.
- We (I), assume full liability for the care and the use of the facility and agree not to hold the school district liable for anything arising of our (my) use of the Mustang Public School facility. We (I) certify that no registered sex offenders are working this/these events(s).
- We (I) further agree to indemnify and save harmless the Mustang School District and the Mustang Board of Education from and against any and all claims and demands whether for injuries to persons or loss of life, or damage to property occurring within the Mustang Schools facility and arising out of the use and occupancy of said facility by us (me), our (my) employees, guests, members, participants and invitees.

Representative's Signature: _____

Date: _____

9/3/13

OFFICE USE ONLY:

Estimated Charge for Use of Facility

Rental of Facility:

Custodial Costs:

Other:

TOTAL COST:

Signatures:

Use of Facilities Coordinator:



Date: 9-4-13

Athletic Director (If applicable):

Date:

Deputy Superintendent of Schools:



Date: 9-4-13

President of Mustang Board of Education:

Date:

Memo

To: Charles Bradley
From: Deborah Beel *DB*
CC: File *CB*
Date: 9/3/2013
Re: Continued Business Associate Agreement

Please review and consider for board approval the continued agreement between Mustang Public Schools and the Oklahoma State Department of Health to utilize the Oklahoma State Immunization Information System (OSIIS). Each site is now required to have a business agreement. The site nurses and nurse assistants utilize this system to obtain required immunization documentation.

Contractor/Business Associate Name as shown or to be shown in OSIS MUSTANG ELEMENTARY	OSIS ID	New User <input checked="" type="checkbox"/>	VFC Pin
---	---------	--	---------

**OKLAHOMA STATE DEPARTMENT OF HEALTH
BUSINESS ASSOCIATE AGREEMENT**

This Business Associate Agreement (BAA), effective on the last signature date below, is entered into by and between the Oklahoma State Department of Health (Covered Entity) and Contractor (Business Associate).

BACKGROUND AND PURPOSE: The Parties have entered into, and may in the future enter into, one or more written agreements that require Business Associate to be provided with, to have access to, and/or to create Protected Health Information (PHI), (the “underlying Contract(s)”), that is subject to the federal regulations issued pursuant to the Health Insurance Portability and Accountability Act (HIPAA) and codified at 45 CFR, parts 160 and 164 (HIPAA Regulations). This BAA shall supplement and/or amend each of the Underlying Contract(s) only with respect to the Business Associate’s Use, Disclosure, and creation of PHI under the Underlying Contract(s) to allow Covered Entity to comply with Sections 164.502(c) and 164.314(a)(2)(i) of the HIPAA Regulations. Business Associate acknowledges that it is to comply with the HIPAA Security and Privacy regulations pursuant to Subtitle D of the Health Information Technology for Economic and Clinical Health Act (HITECH), Title XIII, of the American Recovery and Reinvestment Act of 2009, including Sections 164.308, 164.310, 164.312 and 164.316 of title 45 of the Code of Federal Regulations. Except as so supplemented and/or amended, the terms of the Underlying Contract(s) shall continue unchanged and shall apply with full force and effect to govern the matters addressed in the BAA and in each of the Underlying Contract(s).

DEFINITIONS: Unless otherwise defined in this BAA, all capitalized terms used in this BAA have the meanings ascribed in the HIPAA Regulations, provided, however, that “PHI” and “ePHI” shall mean Protected Health Information and Electronic Protected Health Information, respectively, as defined in 45 CFR § 160.103, limited to the information Business Associate received from or created or received on behalf of the Oklahoma State Department of Health (OSDH) as OSDH’s Business Associate. “Administrative Safeguards” shall have the same meaning as the term “administrative safeguards in 45 CFR § 164.304, with the exception that it shall apply to the management of the conduct of Business Associate’s workforce, not OSDH’s workforce, in relation to the protection of that information.

Business Associate. “Business Associate” shall generally have the same meaning as the term “Business Associate” at 45 CFR 160.103, and in reference to the party to this agreement, shall mean the entity whose name appears below.

Covered Entity. “Covered Entity” shall generally have the same meaning as the term “Covered Entity” at 45 CFR 160.103.

HIPAA Rules. “HIPAA Rules” shall mean the Privacy, Security, Breach Notification, and Enforcement Rules at 45 CFR Part 160 and Part 164, all as may be amended.

The following terms used in this Agreement shall have the same meaning as those terms in the HIPAA Rules: Breach, Data Aggregation, Designated Record Set, Disclosure, Health Care Operations, Individual, Minimum Necessary, Notice of Privacy Practices, Protected Health Information, Required By law, Secretary, Security Incident, Subcontractor, Unsecured PHI, and Use.

Obligations of Business Associate: Business Associate may use Electronic PHI and PHI (collectively, "PHI") solely to perform its duties and responsibilities under this Agreement and only as provided in this Agreement. Business Associate acknowledges and agrees that PHI is confidential and shall not be used or disclosed, in whole or in part, except as provided in this Agreement or as required by law. Specifically, Business Associate agrees it will:

- (a) use or further disclose PHI only as permitted in this Agreement or as Required by Law, including, but not limited to the Privacy and Security Rule;
- (b) use appropriate safeguards, and comply with Subpart C of 45 CFR Part 164 with respect to Electronic PHI, to prevent use or disclosure of PHI other than as provided for by this Agreement;
- (c) implement and document appropriate administrative, physical, and technical safeguards to protect the confidentiality, integrity, and availability of PHI that it creates, receives, maintains, or transmits for or on behalf of Covered Entity in accordance with 45 CFR 164;
- (d) implement and document administrative safeguards to prevent, detect, contain, and correct security violations in accordance with 45 CFR 164;
- (e) make its policies and procedures required by the Security Rule available to Covered Entity solely for purposes of verifying BA's compliance and the Secretary of the Department of Health and Human Services (HHS);
- (f) not receive remuneration from a third party in exchange for disclosing PHI received from or on behalf of Covered Entity;
- (g) in accordance with 45 CFR 164.502(e)(1) and 164.308(b), if applicable, ensure that any subcontractors that create, receive, maintain or transmit PHI on behalf of the Business Associate agree to the same restrictions, conditions, and requirements that apply to the Business Associate with respect to such information; this shall be in the form of a written HIPAA Business Associate Contract and a fully executed copy will be provided to the Contract Monitor;
- (h) report to Covered Entity in writing any use or disclosure of PHI that is not permitted under this Agreement as soon as reasonably practicable but in no event later than five (5) calendar days from becoming aware of it and mitigate, to the extent practicable and in cooperation with Covered Entity, any harmful effects known to it of a use or disclosure made in violation of this Agreement;
- (i) promptly report to Covered Entity in writing and without unreasonable delay and in no case later than five (5) calendar days any Security Incident, as defined in the Security Rule, with respect to Electronic PHI;
- (j) with the exception of law enforcement delays that satisfy the requirements of 45 CFR 164.412, notify Covered Entity promptly, in writing and without unreasonable delay and in no case later than five (5) calendar days, upon the discovery of a breach of Unsecured PHI. Such notice shall include, to the extent possible, the name of each individual whose Unsecured PHI has been, or is reasonably believed by Business Associate to have been, accessed, acquired, or disclosed during such Breach. Business Associate shall also, to the extent possible, furnish Covered Entity with any other available information that Covered Entity is required to include in its notification to Individuals under 45 CFR § 164.404(c) at

the time of Business Associate's notification to Covered Entity or promptly thereafter as such information becomes available. As used in this Section, "breach" shall have the meaning given such term at 45 CFR 164.402;

- (k) to the extent allowed by law, indemnify and hold Covered Entity harmless from all claims, liabilities, costs, and damages arising out of or in any manner related to the disclosure by Business Associate of any PHI or to the breach by Business Associate of any obligation related to PHI;
- (l) provide access to PHI in a Designated Record Set to Covered Entity, or if directed by Covered Entity to an Individual in order to meet the requirements of 45 CFR 164.524. In the event that any Individual request access to PHI directly from Business Associate, Business Associate shall forward such request to Covered Entity within five (5) working days of receiving a request. This shall be in the form of a written HIPAA Business Associate Contract and a fully executed copy will be provided to the Contract Monitor. Any denials of access to the PHI requested shall be the responsibility of Covered Entity;
- (m) make PHI available to Covered Entity for amendment and incorporate any amendments to PHI in accordance with 45 CFR 164.526;
- (n) document disclosure of PHI and information related to such disclosure as would be required for Covered Entity to respond to a request by an Individual for an accounting of disclosures of PHI, in accordance with 45 CFR 164.528, and within five (5) working days of receiving a request from Covered Entity, make such disclosure documentation and information available to Covered Entity. In the event the request for an accounting is delivered directly to Business Associate, Business Associate shall forward within five (5) working days of receiving a request such request to Covered Entity;
- (o) make its internal practices, books, and records related to the use and disclosure of PHI received from or created or received by Business Associate on behalf of Covered Entity available to the Secretary of the Department of HHS, authorized governmental officials, and Covered Entity for the purpose of determining Business Associate's compliance with the Privacy Rule. Business Associate shall give Covered Entity advance written notice of requests from DHHS or government officials and provide Covered Entity with a copy of all documents made available; and
- (p) ensure that all of its subcontractors, vendors, and agents to whom it provides PHI or who create, receive, use, disclose, maintain, or have access to Covered Entity's PHI shall agree in writing to requirements, restrictions, and conditions at least as stringent as those that apply to Business Associate under this Agreement, including but not limited to implementing reasonable and appropriate safeguards to protect PHI, and shall ensure that its subcontractors, vendors, and agents agree to indemnify and hold harmless Covered Entity for their failure to comply with each of the provisions of this Agreement.

Permitted Uses and Disclosures of PHI by Business Associate: Except as otherwise provided in this Agreement, Business Associate may use or disclose PHI on behalf of or to provide services to Covered Entity for the purposes specified in this Agreement, if such use or disclosure of PHI would not violate the Privacy Rule if done by Covered Entity. Unless otherwise limited herein, Business Associate may:

- (a) use PHI for its proper management and administration or to fulfill any present or future legal responsibilities of Business Associate;

- (b) disclose PHI for its proper management and administration or to fulfill any present or future legal responsibilities of Business Associate, provided that (i) the disclosure is Required by Law; or (ii) Business Associate obtains reasonable assurances from any person to whom the PHI is disclosed that such PHI will be kept confidential and will be used or further disclosed only as Required by Law or for the purpose(s) for which it was disclosed to the person, and the person commits to notifying Business Associate of any instances of which it is aware in which the confidentiality of the PHI has been breached;
- (c) disclose PHI to report violations of law to appropriate federal and state authorities; or
- (d) aggregate the PHI with other data in its possession for purposes of Covered Entity's Health Care Operations;
- (e) make uses and disclosures and requests for protected health information consistent with Covered Entity's minimum necessary policies and procedures;
- (f) de-identify any and all PHI obtained by Business Associate under this BAA, and use such de-identified data, all in accordance with the de-identification requirements of the Privacy Rule [45 CFR §(d)(1)].

Obligations of Covered Entity:

- (a) Covered Entity shall notify Business Associate of any changes in, or revocation of, the permission by an individual to use or disclose his or her PHI, to the extent that such changes may affect Business Associate's use or disclosure of PHI.
- (b) Covered Entity shall notify Business Associate of any restriction on the use or disclosure of PHI that Covered Entity has agreed to or is required to abide by under 45 CFR 164.522, to the extent that such restriction may affect Business Associate's use or disclosure of protected health information.
- (c) Covered Entity shall not request Business Associate use or disclose PHI in any manner that would violate the Privacy Rule if done by Covered Entity.
- (d) OSDH agrees to timely notify Business Associate, in writing, of any arrangements between OSDH and the Individual that is the subject of PHI that may impact in any manner the use and/or disclosure of the PHI by Business Associate under this BAA.

Term and Termination:

- (a) Term. The Term of this Agreement shall be effective as of the date of the underlying agreement, and shall terminate on the date the underlying agreement terminates or on the date Covered Entity terminates for cause as authorized in paragraph (b) of this Section, whichever is sooner.
- (b) Termination for Cause. Business Associate authorizes termination of this Agreement by Covered Entity, if Covered Entity determines Business Associate has violated a material term of the Agreement (and Business Associate has not cured the breach or ended the violation within the time specified by Covered Entity if a cure period is specified).
- (c) Obligations of Business Associate Upon Termination.

Upon termination of this Agreement for any reason, Business Associate, with respect to PHI received from Covered Entity, or created, maintained, or received by Business Associate on behalf of Covered Entity, shall:

1. Retain only that PHI that is necessary for Business Associate to continue its proper management and administration or to carry out its legal responsibilities;
2. Return to Covered Entity (or, if agreed to by Covered Entity, destroy) the remaining PHI that the Business Associate still maintains in any form;
3. Continue to use appropriate safeguards and comply with Subpart C of 45 CFR Part 164 with respect to PHI to prevent use or disclosure of the PHI, other than as provided for in this Section, for as long as Business Associate retains the PHI;
4. Not use or disclose the PHI retained by Business Associate other than for the purposes for which such PHI was retained and subject to the same conditions set out at above under "Permitted Uses and Disclosures By Business Associate" that applied prior to termination; and
5. Return to Covered Entity (or, if agreed to by Covered Entity, destroy) the PHI retained by Business Associate when it is no longer needed by Business Associate for its proper management and administration or to carry out its legal responsibilities.

(d) All other obligations of Business Associate under this Agreement shall survive termination.

Should OSDH become aware of a pattern of activity or practice that constitutes a material breach of a material term of this BAA by Business Associate, OSDH shall provide Business Associate with written notice of such a breach in sufficient detail to enable Contractor to understand the specific nature of the breach. OSDH shall be entitled to terminate the Underlying Contract associated with such breach if, after OSDH provides the notice to Business Associate, Business Associate fails to cure the breach within a reasonable time period not less than thirty (30) days specified by OSDH in such notice; provided, however, that such time period specified by OSDH shall be based on the nature of the breach involved [45 CFR §§ 164.504(e)(1)(ii)(A),(B) & 164.314 (a)(2)(i)(D)].

MISCELLANEOUS:

Interpretation: The terms of this BAA shall prevail in the case of any conflict with the terms of any Underlying Contract to the extent necessary to allow OSDH to comply with the HIPAA Regulations. The bracketed citations to the HIPAA Regulations in several paragraphs of this BAA are for reference only and shall not be relevant in interpreting any provision of this BAA.

No Third Party Beneficiaries: Nothing in this BAA shall confer upon any person other than the parties and their respective successors or assigns, any rights, remedies, obligations, or liabilities whatsoever.

Business Associate recognizes that any material breach of this Agreement or breach of confidentiality or misuse of PHI may result in the termination of this Agreement and/or legal action. Said termination may be immediate and need not comply with any termination provision in the parties' underlying agreement, if any.

The parties agree to amend this Agreement from time to time as is necessary for Covered Entity or BA to comply with the requirements of the Privacy Rule and related laws and regulations.

(a) OSDH's Notice of Privacy Practices is available on its website: www.ok.gov/health.

- (b) Any ambiguity in this Agreement shall be resolved in a manner that causes this Agreement to comply with HIPAA.
- (c) This Agreement embodies and constitutes the entire agreement and understanding between the parties with respect to the subject matter hereof and supersedes all prior Business Associate agreements, oral or written agreements, commitments, and understandings pertaining to the subject matter hereof.
- (d) If Business Associate maintains a designated record set in an electronic format on behalf of Covered Entity, then Business Associate agrees that within 30 days of expiration or termination of the parties' agreement, Business Associate shall provide to Covered Entity a complete report of all disclosures of and access to the designated record set covering the three years immediately preceding the termination or expiration. The report shall include patient name, date and time of disclosures/access, description of what was disclosed/accessed, purpose of disclosure/access, name of individual who received or accessed the information, and, if available, what action was taken within the designated record set.

Amendment: To the extent that any relevant provision of the HIPAA Regulations is materially amended in a manner that changes the obligations of Business Associates or Covered Entities, the Parties agree to negotiate in good faith appropriate amendment(s) to this BAA to give effect to these revised obligations. The parties agree to amend this Agreement from time to time as is necessary for Covered Entity or to comply with the requirements of the Privacy Rule and related laws and regulations.

A signed copy of this agreement shall be accorded the same force and effect as the original.

IN WITNESS WHEREOF, each of the undersigned has caused this BAA to be duly executed in its name and on its behalf.

OKLAHOMA STATE DEPARTMENT OF HEALTH

CONTRACTOR

By: _____

By: _____
Authorized Facility Administrator Signature

Print Name: Robn Green, MPH

Print Name: _____

Print Title: HIPAA Privacy Officer

Print Title: _____

Date: _____

Date: _____ Phone # _____

The original form must be mailed to:

Immunization Service
Oklahoma State Department of Health
1000 NE 10th Street
Oklahoma City, OK 73117-1299

For questions, call Stephanie Natt at 405.271.4073.

Contractor/Business Associate Name as shown or to be shown in OSIIS	OSIIS ID	New User <input checked="" type="checkbox"/>	VFC Pin
MUSTANG ELEMENTARY			

**OKLAHOMA STATE DEPARTMENT OF HEALTH (OSDH)
OKLAHOMA STATE IMMUNIZATION INFORMATION SYSTEM (OSIIS)
FACILITY AUTHORIZATION REQUEST**

FACILITY NAME <u>MUSTANG ELEMENTARY</u>		New User: <input checked="" type="checkbox"/> Yes <input type="checkbox"/> No	
ADDRESS <u>400 S MUSTANG RD</u>		VFC PIN #:	OSIIS ID #:
CITY <u>MUSTANG</u>	COUNTY <u>CANADIAN</u>	STATE <u>OK</u>	ZIP <u>73064</u>
PHONE (405) <u>376-2491</u>		FAX (405) <u>376-7338</u>	
FACILITY TYPE (Please Check One) <input type="checkbox"/> County Health Department <input type="checkbox"/> Hospital – Public <input type="checkbox"/> Rural Health Clinic <input type="checkbox"/> Day Care <input type="checkbox"/> IHS / Tribal <input checked="" type="checkbox"/> School <input type="checkbox"/> Federally Qualified Health Center <input type="checkbox"/> Military <input type="checkbox"/> State / Federal Agency <input type="checkbox"/> HMO <input type="checkbox"/> Private Facility <input type="checkbox"/> Counseling Services <input type="checkbox"/> Hospital – Private <input type="checkbox"/> Public Facility		(Please check below) Does this facility obtain vaccine from the Oklahoma State Health Department? <input type="checkbox"/> YES <input type="checkbox"/> NO If no, will this site be a view only site? <input type="checkbox"/> YES <input type="checkbox"/> NO	

IMPORTANT - PLEASE READ

Obtaining user access to the OSIIS will provide your facility access to immunization information for any person entered into the system. Access to this system is granted only for the purposes of recording and/or verifying immunization requirements. This information is to be shared on an as needed basis only with school officials, public health officials, child day care centers, other health care professionals or health institutions, the person's legal guardian, or other institutions required by law to collect immunization records. All records are considered confidential and covered by the Health Insurance Portability and Accountability Act of 1996 (HIPAA). Facilities must obtain a written authorization from the individual for the use and disclosure of protected health information unless the disclosure is to the individual, for treatment, payment, or health care operations, or the disclosure falls under a specified exception.

The facility will provide its staff member's access to computer equipment and electronic communications necessary to operate the OSIIS. The facility agrees to enter client demographic and immunization information into the OSIIS in a timely manner for those receiving immunizations at the facility. The OSDH will periodically monitor the facility and user's activities related to usage of the OSIIS.

The facility will assign an account administrator to be responsible for this facility's OSIIS account. The account administrator will be responsible for the following:

- Creation of additional individual user accounts to be assigned to this facility
- Setting or changing each user's access level
- Immediately removing access to OSIIS for users who leave your employment
- Notification to OSIIS of any facility changes such as site name, address, phone/fax number, account administrator, or the closing of the facility

OSIIS Account Administrator

Signature: _____

Phone: 405-376-7944

Name: ASHLEY ARMSTRONG

E-mail: ARMSTRONGA@MUSTANGPS.ORG

Title: NURSE

OSIIS Account Administrator #2

Signature: _____

Optional

Phone: 405-376-7944

Name: AMBER WAGGONER

E-mail: WAGGONERA@MUSTANGPS.ORG

Title: NURSE ASSISTANT

Authorized Facility Administrator (signature)

Title

Date

Please return form to:

Oklahoma State Department of Health
1000 N.E. 10th Street OSIIS, Room 915
Oklahoma City, OK 73117

Fax: (405) 271-6133

Phone: (405) 271-7200

USE OF FACILITY AND/OR GROUNDS

The MPS Board of Education believes that the primary use of school buildings, facilities, grounds and equipment is for the educational program. Approval must be secured before any MPS facility can be utilized. No facility may be rented at times when it will interfere with school activities or the general operation of the District. ~~The All~~ 'Use of Facility' ~~forms~~ packets are to be obtained from the ~~Administrative Assistant's office at the~~ MPS Administration Building, 906 South Heights Drive, Mustang, Oklahoma or ~~online at~~ www.mustangps.org.

The following guidelines apply for use of MPS facilities:

1. There will be no unauthorized use of MPS facilities.
2. Any person providing services to MPS students must submit a 'Use of Facility Request' and follow all stated requirements.
3. Facilities may be used by PTA's or other parent/teacher groups for any program dealing with schools without charge if the building is normally open and custodians are on duty.
4. Bluebirds, Brownies, Campfire Girls, Girl Scouts, Cub Scouts, Boy Scouts and/or neighborhood/homeowners associations are approved to hold their regular meetings in school facilities without charge if the meeting is held on a regular school day and concluded by 8:30 p.m.
5. Adult sponsors must supervise the activities at all times. ~~Non - participates must be monitored, if in attendance of the activities.~~ Activities must be confined to the area assigned.
6. No intoxicants, narcotics or tobacco products shall be used in or around school buildings and grounds.
7. ~~Use or possessions of dangerous or offensive weapons are not allowed on the premises or property of Mustang Public Schools.~~
8. ~~7.~~ Proof of liability insurance must be provided before renting any facility. A copy of the certificate must be provided with each request. Mustang Public Schools must be named on the policy as a co-insured.
9. ~~8.~~ MPS Alumni Associates are approved to hold their alumni functions in school facilities without charge. ~~Charges will apply for the use of food service areas.~~
10. ~~9.~~ Any special or one-time event may be approved by a five (5) member committee. ~~chaired by the Administrative Assistant.~~ The committee will determine the merits of use and any associated fees or fee waivers.
11. ~~10.~~ Hours when MPS facilities may be used:
 - Mondays, Tuesday, Thursdays and Fridays – 6:00 p.m. to 9:00 p.m.
 - Wednesday – no facility can be used
 - Saturdays – 8:00 a.m. to 9:00 p.m.
 - Sundays – 1:00 to 5:00 p.m.
 - If school is closed due to inclement weather, there will be no use of facilities.
12. Upon completion of the ~~form,~~ use of facility form, the felony checks and sex offender registry form and the proof of liability insurance are ~~is~~ to be returned to the MPS Administration Building, 906 South Heights Drive, Mustang, Oklahoma. ~~along with the certificate of insurance, thirty (30) days prior to the regular Mustang Board of Education meeting.~~

- 13. The MPS Board of Education will approve or deny the request. Expenses for all facilities will be billed following the board meeting at which approval is granted and will be payable upon receipt of invoice. Payment is to be received by MPS before the facility can be used.
- 14. ~~11.~~ Mustang Public Schools reserves the right to revoke any use of facility for cause.
- 15. ~~42.~~ The Mustang Board of Education shall be the final authority in matters not covered by this policy.

Adopted: 12-98
Revised: 10-01
Revised: 06-03
Revised: 08-03
Revised: 07-06
Revised: 06-10
Revised: 07-10
Revised: 07-12
Revised: 09-13

CONTINGENT AGREEMENT

Contingent upon Mustang Public Schools receiving a Small Grant Support for Schools from the Oklahoma Arts Council in the amount of twenty-four hundred and seventy-five dollars (\$2475.00), and MHS PASS Alternative school supplying two hundred seventy-five dollars (\$275.00) from Activity account 901, Todd Wisdom, artist, and Mustang Public Schools agree as follows:

Todd Wisdom, artist, will provide a minimum of 68 hours of on-site dance instruction/therapy to the students at Mustang Education Center enrolled in the MHS PASS program for the period of every Tuesday beginning the week of October 22, 2013 through March 25, 2014.

In consideration for his services, artist will receive \$40.00 per hour of on-site instruction. Artist will submit a statement of on-site hours taught on a monthly basis and be paid his hourly rate.

This is the entire agreement between the parties. Any changes or supplement to this agreement shall be in writing and executed by both parties. Canadian County, State of Oklahoma, shall be sole jurisdiction in which to settle any dispute arising under the Contingent Agreement.

Dated this _____ day of _____ 2013.

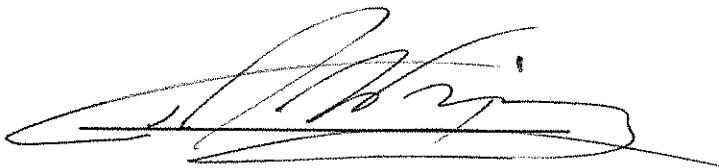

Artist



Mustang Independent School District

Small Grant Support for Schools Application

Mustang Alternative School

1.
791530913



Legal Assurances

1. Do you accept the legal assurances? Yes

2. The Applicant agrees that:

1. It will comply with Title VI of the Civil Rights Act of 1964 (P.O. 88-132) and in accordance with Title VI of the Act, no person in the United States, shall on the grounds of race, color, or national origin be excluded from participation in, be denied the benefits of, or otherwise be subjected to discrimination under any program activity for which the applicant received federal or state assistance and will immediately take any measures necessary to effectuate this agreement.
2. It will comply with Section 504 Rehabilitation Act which mandated that no otherwise qualified handicapped individual in the United States shall, solely by reason of his/her handicap, be excluded from participation in, be denied the benefits of or be subjected to discrimination under any program or activity receiving federal financial assistance.
3. It will comply with Title IX of the Education Amendment of 1972 which provides that no person in the United States shall, on the basis of sex, be excluded from participation in, be denied the benefits of or be subjected to discrimination under any education program or activity receiving federal or state financial assistance
4. It will comply with the Drug-Free Work Place Act of 1988 which requires recipients of federal financial assistance to certify that they will provide a drug-free work environment.
5. It will give the State of Oklahoma, the Oklahoma Arts Council or the Federal Government through any authorized representatives, the access to and the right to examine all records, books, papers or documents relating to this assistance.
6. Funds shall not be applied, donated or used directly or indirectly for the use, benefit or support of any sect, church, denomination or system of religion, for the use, benefit or support of any priest, preacher, minister or other religious teacher for dignitary or sectarian institution as such.
7. Funds granted will be expended solely for activities described in the application. Changes in the approved application can be made only upon the Council's receipt of a written request. Written approval of the Council must be received prior to changes. Failure to comply may result in termination of approved financial assistance.
8. The applicant's indicated acceptance of the Council's assistance and terms by returning the electronic Oklahoma Arts Council Contract, signed by the due date indicated in the award notification. Failure to return the Oklahoma Arts Council Contract will result in the termination of the approved assistance
9. Applicant will submit a Final Report, if applicable, to the Council within the prescribed time period for the program (usually 30 days) after the ending date of the project. Failure to return the Final Report will result in the termination of the approved assistance.
10. Applicant will keep complete and separate financial records for a period of three years, which adequately identify the source and use of Council assistance
11. The figures, facts and representations in this application, including all exhibits and attachments, are true and correct to the best of the authorizing official's knowledge and belief.
12. Notwithstanding any other provisions of this agreement, the parties acknowledge and agree that funds paid by the Oklahoma Arts Council under the terms of this agreement will be available only as appropriated on a fiscal-year basis by properly constituted legal authority. In the event that the funds available for financial assistance are reduced or canceled, the parties agree that any amounts of money shown in this agreement may be reduced accordingly or the agreement may be canceled in its entirety upon written notice by the Oklahoma Arts Council. The Council reserves the right to close any category if deemed necessary
13. It will comply with the Americans with Disabilities Act of 1990 ("ADA") which prohibits discrimination on the basis of disability in employment (Title I), State and local government services (Title II), and place of public accommodation and commercial facilities (Title III).
14. It will comply with the Age Discrimination Act of 1975 which provides that no person in the United State shall, on the basis of age, be excluded from participation in, be denied the benefits of, or be subjected to discrimination under any program or activity receiving federal financial assistance.

15. All promotional material for funded projects must the Oklahoma Arts Council logo, the National Endowment for the Arts logo and may include the following credit line: "With the assistance of the Oklahoma Arts Council and the National Endowment for the Arts". Failure to provide appropriate credit may result in the termination of the approved financial assistance.

3. **Please enter the name of the person with authority to agree to the Legal Assurances. Completion of this field represents a binding electronic signature.**

Michael Ossenkop

Application Support Material

Small Grant Support for Schools: Support Material Instructions

1. Cover Sheet: Name of Organization, address, phone number, e-mail address, primary contact name.
 2. Table of contents
 3. Signed and dated artist contract(s) including: name(s) of artist, dates of service, services provided and fee for service
 4. Bio(s) of artist(s) and/or resumes
-

Dancing Into Fitness

Arts Education in Schools Project Information #2863-4417

1. **Project Dates**

Project Beginning Date: 10/22/2013

Project Ending Date: 03/25/2014

2. **Enter the total number of youth that will receive direct benefit from this project as audience members or as participants.**

130

3. **Enter the total number of adults that will receive direct benefit from this project as audience members or as participants.**

10

4. **Enter the name, phone number and /or e-mail address of the project coordinator.**

Del Ann Easter Easterd@mustangps.org 405-376-7322 405-973-4576

Project Budget

Expenses		Income	
Outside Administration	\$0	Schools Contribution	\$275
Outside Artistic	\$2750		
Supplies	\$0		
Student Travel	\$0		
Other	\$0		
Expense Total	\$2750	Request	\$2475
		Income Total	\$2750

Budget Narratives

1. Describe and itemize any other expenses and supplies. Enter NA if this does not apply.
NA
 2. Describe how OAC funds will be used and include an itemized list of supplies. Not to exceed 25% of total cost of project.
All of the money would go to pay our artist. He would be paid \$45.00 per hour of instruction.
-

Project Description

1. Describe the project in depth. Discuss the arts activities including arts instruction and hands-on learning.

The physical aspect of dancing is challenging and invigorating and uses active learning rather than passive instruction. Many students get little to no physical exercise on a regular basis and dance provides another outlet for those who do or would not regularly participate in physical activities. The students learn about body language with a focus on posture, poise, and eye contact and other types of physical communication. This translates into the workplace, higher education, and other interview and life situations. The character and confidence building lessons learned in ballroom dance are enriching and even vital in many students' personal growth. By its nature dance is a celebration of the beauty and movement of the human form. Every student who learns to dance experiences Cinderella or Prince Charming moments wherein they see themselves capable of things they may never have thought possible. The students learn self-confidence and they learn to respect and appreciate others on the dance floor. The dancing instruction is designed to work hand-in-hand with parents and teachers to create and cultivate an environment of respect and admiration to be reciprocated between the student, parent, teacher, and peers.

Project Artists

Todd Wisdom

Fee: 40.00 per hour

Oklahoma Teaching Artist

Service Description: Todd will provide 4 hours of dance instruction every Tuesday that he comes to MEC.

Project Educational Merit

1. Enter the number of individuals receiving hands-on instruction. This number should only reflect the target population for this project.
130
2. Enter the number of teachers receiving teacher training in arts education. Enter 0 (zero) if not applicable.
0
3. Enter the number of sites served by this project.
1
4. Please indicate the number of rural school sites. (Located outside the Oklahoma City and Tulsa metropolitan areas.)
1
5. Please select the grade levels that will be receiving hands-on instruction. Select all that apply.
 - Grades PreK-5
 - Grades 6-8
 - Grades 9-12 ✓
 - Teacher Training
6. List the arts learning goals for this project. These goals should include specific artistic techniques, concepts and methods the participants will learn. (Example: For a three-week pottery course, students will demonstrate knowledge of coil technique and the ability to create a ceramic vessel. Students will implement the concepts of symmetry and balance.)
Each week will consist of primarily two methods of instruction. Most classes will open with discussion/lecture in which we relate dance/art including the principles and motive that drive this along with other art forms. This is an interactive time with a primary goal of building repertoire and teaching methods of successful living. The method is the actual hands-on dance instruction in which the students will learn in each dance; (1) the steps and footwork (2) partnership including how to lead and/or follow the dance (3) the style and technique of the particular dance (4) hearing the music and tempo (5) social dancing/putting all of this together on the dance floor. The dream and desire for this program is to foster

personal and community growth in the students and the greatest success would be watching them succeed on the dance floor and in their lives and relationships. The ballroom dancing art instruction course is designed to take students from having little or no previous dance experience to the level of an accomplished social dancer who is proficient in five major dances, able to teach others using leading and following methods, and have a deeper appreciation of music, culture, and art. The ballroom dancing also serves as a vehicle to teach a myriad of relational and personal life skills such as, interpersonal relations, forming and maintaining connections, decision-making, embracing diversity, living with passion, accomplishing goals, along with other skills and community values.

7.

Each participant would be actively involved in the dance class for a minimum of 15 hours. There will be 4, hour long classes of 15 students each week for one day. We serve 60 students at one time, but they graduate and new ones are added throughout the year. We usually end up serving close to 130 students throughout a school year.

Evaluation Methods

1. Please select at least one type of evaluation from each of the two lists below that you will use to measure student learning/teacher training. You may select all that apply.

- Pre-Post Testing
- Rubric-Measuring subject content ✓
- Short Answer Questionnaire
- Skills Testing
- Student Essay/Report
- Written/Oral Exam

- Instructor/Class Critique ✓
- Self/Peer Assessment
- Student Journal
- Student Survey
- Teacher Survey
- Other

2. List two or three sample questions for evaluation methods checked above used to measure participants' learning.

Rubric- steps and footwork- 76%; partnership- 85%; style and technique- 70%; music and timing- 81%; social dancing- 87%. Instructor asks students to demonstrate dance steps. Instructor asks students to tell about the culture behind a given dance. Class takes turns evaluating each other. They change partners and see how well they can pick up on the body language of a new partner.

Community Need

1. Select the number of years this project has taken place.
over 10

2. As the legislature faces difficult budget decisions for state agencies, how would the decrease or loss of public funding for the arts impact your organization, project and/or community?

In previous years we have funded our art projects through the Arts in Alternative School Grant. Then we learned about this Small Grant Support for Schools when the previous avenue was not available. We would not be able to have an artist come to our alternative school and teach our students if it were not for the funding through this grant. School budgets are very tight and there isn't enough money to fund such projects. Our students would not learn to dance or the importance of a dancing relationship without this grant. They would not be able to go to wedding receptions and dance or social dance without this instruction. Our community newspaper has done an article with pictures nearly every year. It is usually the only time our students receive positive praise in public.

Logged in as Del Ann Easter for Mustang Alternative School on Wednesday 7th of August 2013 10:01:00 AM

Oklahoma Arts Council P.O. Box 52001-2001 Oklahoma City OK 73152-2001 phone 405.521.2931
okarts@arts.ok.gov

Memo

Date: 9/9/2013
To: Dr. Angela Mills *AM CB*
From: Gaile Loving
RE: Mini Math and Science Partnership Grant

Please submit to the board for consideration and/or action the request to approve Mustang Public Schools participation in a Mini Math and Science Partnership Grant. The project, **Leading by Example for Engineering Design (LEED)**. Mustang Public Schools will be working in conjunction with six other public school districts and the University of Central Oklahoma. This grant gives math and science teachers extensive professional development opportunities. Teachers will develop engineering design components for both math and science content while focusing on best instructional practices and leadership within the STEM subjects.

The grant amount (\$58,476.23) is funded through the Oklahoma State Department of Education. Putnam City Public Schools will serve as the lead LEA, handling all financial transactions. The district will not incur any costs associated with the project. All professional development will be held on Saturdays during the months of October – February.

Respectfully submitted,

Gaile Loving

Gaile Loving
Science Curriculum Coordinator
Mustang Public Schools

Leading by Example for Engineering Design (LEED) Math and Science Partnership Grant

Training future engineers is critical for sustained innovation and security in the United States. This need has been formalized for K-12 within the Next Generation Science Standards (NGSS) where engineering design (ED) was chosen to be integral. ED is a new concept for K-12 teaching, and teacher leaders are needed to implement ED in classrooms.

Very few teachers have engineering degrees, making the connection between teachers and engineers very important. UCO engineering faculty active in their engineering discipline will work with LEED participants to relate engineering design to the Crosscutting concepts in the NGSS. These relationships will be drawn using real-world examples that connect to science concepts and provide LEED participants with ready-to-use content at their schools. The faculty will assist the participants to develop ED examples and content that can be directly used at partner schools.

Mustang Public Schools will be joining with six other public school districts, and the University of Central Oklahoma (UCO) to provide teacher professional development under the direction of a Math and Science Partnership grant. Participating districts include: Putnam City Public Schools, Norman Public Schools, Edmond Public Schools, Deer Creek Public Schools, Minco Public Schools, Oklahoma City Public Schools, and Mustang Public Schools. Putnam City Public Schools will serve as the Lead Educational Agency (LEA) being responsible for providing the grant project director and handling all financial and business arrangements for the project.

The program's goals are:

- To train teacher-leaders in the Engineering Design Cross-Cutting ideas that are a part of the Next Generation Science Standards and the prospective Oklahoma Academic Science Standards (OASS) which are to be infused into all science courses.
- To develop teacher-leaders in the subject areas of secondary science and math. High School Science and Math Department chairs or other teacher leaders within those departments, etc., would be participants. The specific science or math subject concentration of the applicant does not matter, however the workshops will have a heavy science emphasis.
- To build for the future, LEEDS will help teacher-leaders jump-start the transition to the new standards-based instructional design required of the OASS.

Mustang's Math and Science goals are:

- To build an integrated cross-curriculum STEM leadership team between the High School science and math departments.
- To work effectively at increasing the ED content knowledge of fellow teachers through established Professional Learning Communities (PLC).

Participant space allotment and obligation:

- There are a total of 37 teacher spaces allotted for the entire grant.
- Initially, each partner district can submit up to five teachers.
- Unused teacher spaces will be transferred to other partner districts until all the available participant slots are taken. Mustang could place additional teachers within the program.
- Each teacher participant will be obligated to attend all four days.

Workshop Dates: LEED will consist of a set of four workshops at UCO. The four (4) Saturday meeting dates are still to be determined, however the initial three meetings will be held in October and November (with November 2nd as one of the dates). The culminating LEED activity will be the LEED conference on the UCO campus in which participating teachers will disseminate the examples of content they have developed. Specific date information will be provided before the teacher makes a final commitment.

Stipend: Participants will receive \$600 plus benefits (\$792 total) for participating in the 3 workshop days plus the LEED Conference on Engineering Design.

TITLE: NURSE ASSISTANT

QUALIFICATIONS: High School Diploma: Working knowledge of basic office procedures and the operation of common office equipment. Demonstrates positive attitude toward school environment.

Reports To Principal/assistant Principal/Registered Nurse

PERFORMANCE RESPONSIBILITIES

1. Administers first aid and medication to students according to district policy and procedures
2. Assists and participates in the implementation of the communicable disease program and screenings
3. Communicates effectively with school nurse, staff and parents regarding health care needs and concerns for the purpose of referring students in need of further treatment.
4. Follows medical emergency plans and maintains health records for the purpose of providing information required by legal and professional standards.
5. Performs record keeping and clerical functions under strict confidentiality for the purpose of supporting the health services staff.
6. Performs specialized treatments as delegated by appropriate personnel monitored and evaluated by school nurse.
7. Supervises students referred for illness and/or injury for the purpose of monitoring their care and maintaining order in the health room.
8. Maintains such student records as required
9. Performs other tasks and health related duties as assigned by supervisor.

Mustang Public Schools

*Gifted and Talented
Education Plan
2013*



Gifted and Talented Education Plan

Mustang Public Schools

Mustang, Oklahoma

Philosophy:

The gifted and talented education program of Mustang Public Schools, GATE, is an integral part of our commitment to provide for the unique needs, interests, skills, and talents of identified gifted students. We believe identified gifted and talented youth need differentiated instructional strategies, materials, and expectations which take into account their special abilities and potential. The gifted and talented program should contribute to each student's development in the areas of talents and abilities, self-concept, social acceptance, and skills related to independent study, research, creativity, performance, critical thinking, and problem-solving.

GATE is intended to enhance and enrich experiences in regular classrooms, providing an expansion of the existing curriculum. The development of lifelong learning is the purpose of GATE, as students are challenged to develop their abilities for both personal fulfillment and significant contributions to society.

Definition of Gifted and Talented Students:

"Gifted and talented students" refers to those students identified as having demonstrated potential abilities of high performance capability, requiring differentiated or accelerated curriculum or educational programs. For the purpose of this definition, "demonstrated abilities of high performance capability" refers to those students identified by scoring in the top 3% on any nationally standardized intellectual ability assessment. This definition may also include students who excel in one or more of the following areas:

- creative thinking ability
- leadership ability
- visual/performing arts ability (subject to audition)
- specific academic ability (i.e. accelerated classes, honors curriculum, Pre-AP, and AP coursework)

Definition of Gifted and Talented Programs:

"Gifted and talented child educational programs" means those special instructional programs, supportive services, unique educational materials, learning settings, and other educational services which differentiate, supplement and support the regular program in meeting the needs of the gifted and talented child." (70. O.S.1210.301)

Goals:

Opportunities are provided for students to be considered for placement in gifted and talented programming throughout their school experiences. Procedures used in the identification

process are non-discriminatory with respect to race, economic background, national origin, or handicapping condition. Identification procedures are uniformly implemented and communicated to the entire school staff through distribution of the "Gifted and Talented Education Plan," posted on the district website at www.mustangps.org or a written copy may be obtained from each school site and the Mustang Public Schools Administration Building.

Central office personnel, site principals, counselors, and the GATE instructors will assist staff with questions and referral procedures. Instructionally useful information about individual students obtained during the identification process is communicated to the appropriate personnel, irrelevant of placement or non-placement.

Categories and State Funding:

Students with Demonstrated Abilities of High Performance Capability

Those students identified by scoring in the top 3% on any nationally standardized intellectual ability assessment as defined by state statute may be eligible for placement in the GATE program. Weighted state funding is provided for these students.

Students Identified Based on Multi-criteria

Students identified based on district approved multi-criteria as specified in the plan may also be eligible for placement in the GATE program. Weighted state funding provided for students served in the GATE program is restricted. This funding is applicable for a maximum of 8% of the district's "average daily membership" or ADM. The restriction is for weighted state funding only. The district may serve any number of students who may qualify.

Referrals:

School professionals, parents, peers, and the students themselves may make referrals for gifted and talented identification. Referrals will be made to the counselor(s) of the appropriate site. Data will be collected on the referred student and may include, but is not limited to, scores on standardized ability and/or achievement tests, student grades within specific academic areas, project portfolios, and other information as appropriate. Referral information and a signed "parent permission to evaluate" form will be forwarded to the director of instructional programs.

Students entering the school district who have been placed in a gifted and talented program in another district will automatically be screened for placement in the GATE program and will be placed if the student meets the criteria established by Mustang Public Schools. Additional testing may be administered if necessary to meet the established district criteria for placement.

Additional Testing:

Parents have the right to request, in writing, a subsequent nationally standardized intellectual ability assessment. In the event a parent desires an additional evaluation, the test must be a nationally standardized test of intellectual ability and may not replicate previous student testing. It must be secured through another source or agency in order for the district to consider it valid. This evaluation will be at parent expense.

Eligibility:

- A score in the top 3% on any nationally standardized intellectual ability assessment, according to the law of the State of Oklahoma, results in automatic placement into appropriate gifted programming options with parental approval.
- Student placement decisions in the capability areas will be based on multiple criteria.
- Uniform identification procedures will be used to identify students for specific gifted educational programming options.
- To allow for the unbiased assessment of all cultural and economic backgrounds, a placement decision will be based on referral, performance, appropriate checklists, and other relevant information. The office of gifted education may authorize the use of alternative assessment procedures when appropriate for a student.
- Placement will be made in programming options appropriate to the student's educational needs, interests, and/or abilities with parental approval.
- Placement in talented programs is subject to annual auditions.

Placement and Notification of Parents/Guardians and Teachers:

Parents or guardians will be notified in writing of test results and/or eligibility for placement in the gifted and talented program. With parent/guardian permission, placement will be made in program options appropriate to the student's educational qualifications, needs, interests, and/or abilities.

When a child qualifies for placement in the gifted program based on the results of any nationally standardized intellectual ability assessment, a placement conference may be held with the school staff and parent prior to placement. Parents may request conferences or consultation as desired.

Either the school counselor, GATE teacher and/or director of instructional programs shall notify teachers in writing of those students who will be served in the GATE program.

Teachers serving these students shall be assisted through professional development training opportunities designed to assist in accommodating the needs of these students.

Questions regarding referral, screening, testing, and placement of students should be directed to the school counselor or director of instructional programs. Appeals, questions, or concerns regarding placement of students should be made in writing to the director of instructional programs of Mustang Public Schools.

Review of Progress:

The progress of students in the gifted program is assessed with attention to mastery of content, higher-level thinking skills, and creativity. At the elementary level, upon completion of units of study, student portfolios will be sent to parents accompanied by an informative non-graded evaluation with comment. Additional communication with parents may occur as needed throughout the school year.

~~For students placed in the talented program for academic team competitions, the appropriate teachers will report student progress and/or group accomplishments.~~

For students placed in the talented program by participation in selected groups of vocal, instrumental, visual, and performing arts, the appropriate teachers will report progress and/or group accomplishments to the parent.

Removal from Program:

Students may be removed from a program which is not meeting their educational needs following a conference which includes the student's parent(s), teacher(s), and administrative representative(s).

Students whose needs are not being met by current placement will be considered for other programming options which may be more appropriate to their needs.

The parent of a gifted program student will be given the option to complete an "Exit Interview" form when:

- student participation in all GATE program options is refused
- removal of the student from GATE program options is desired

This form will allow parents the opportunity to express in writing the reason(s) for non-participation by their student in the district program options. Students may not move in- and-out of the GATE program within a school calendar year, unless extenuating circumstances deem interrupted attendance to be appropriate. Should an interruption of GATE participation occur, a conference with a parent/guardian, classroom teacher, and GATE teacher will preface such program interruption.

Regular Classroom Assignment Modifications:

Identified gifted students should not be penalized for participation in GATE classes and activities. Every effort should be made by regular classroom teachers and administrators to:

- avoid presenting new concepts
- post assignments presented in order for students to be aware of content covered
- schedule tests around GATE time
- schedule school-wide events around GATE time
- exempt students from daily practice and/or drill work, including homework, completed or assigned during a student's GATE time.
- ensure GATE students are not given additional homework
- ensure GATE attendance is not associated with behavior and/or homework completion

Program Options:

Differentiated education includes multiple programming options and curriculum which is modified in pace, breadth, and depth. Programming options are coordinated to guide the development of gifted and talented students from the time they are identified through graduation from high school. Student placement in programming options is based on

qualifications, abilities, needs, and interests. Gifted and talented educational programming is an on-going consideration of the school curriculum and schedule.

Curriculum for the gifted and talented is an extension of the regular curriculum. It is differentiated in content, process, and/or product. Instructional practices for gifted and talented students stress creativity, performance, and higher level thinking skills. Gifted and talented students may also be served informally through various school organizations and clubs, which pertain to their specific needs, interest, and abilities.

Elementary Gifted Program Options:

GATE, the district elementary gifted and talented educational programming will include:

- GATE resource room access for identified gifted elementary students for a specified time once a week
- individualization of instruction for a focused or specific educational need
- proficiency based promotion for any student who scores 90% or above on designated assessments in all core curriculum areas
- differentiated or enriched classes including differentiated and/or accelerated content designed for qualified students
- mutually agreed upon independent study or contracted in-depth study of a specified topic, course, or unit of study
- continuous progress/acceleration of content and pacing of curriculum and instruction which is matched to the students' abilities and needs. Students move ahead on the basis of content mastery
- cross-grade grouping providing opportunity for a student to work in an advanced grade level setting with one or more students sharing a similar readiness for the learning task and performance expectation
- providing opportunities for identified gifted students to serve as resident topic or unit of study experts within the regular classroom setting
- academic and talent competition participation such as local, regional, state, or national contests in a variety of areas such as science fairs or other academic and fine arts competitions
- guidance and counseling sessions and activities to assist identified gifted students in planning their course selections for future academic and career pursuits

5th/6th Grade Intermediate Center Gifted Students Program Options:

- advanced curriculum in mathematics
- proficiency based promotion for any student who scores 90% or above on designated assessments for all curriculum areas
- C³ Fair (College, Career, and Citizen awareness)
- advanced communication program options
- cross-grade grouping providing opportunity for a student to work in an advanced grade

level setting with one or more students sharing a similar readiness for the learning task and performance expectation

- providing opportunities for identified gifted students to serve as resident topic or unit of study experts within the regular classroom setting
- academic and talent competition participation such as local, regional, state, or national contests in a variety of areas such as science fairs or other academic and fine arts competitions
- guidance and counseling sessions and activities to assist identified gifted students in planning their course selections for future academic and career pursuits

Middle School Gifted Student Program Options:

- advanced curriculum in mathematics
- honors course work utilizing inquiry approach with Pre-AP teaching strategies
- proficiency based promotion for any student who scores 90% or above on designated assessments for all curriculum areas
- Engineering Fair participation
- cross-grade grouping providing opportunity for a student to work in an advanced grade level setting with one or more students sharing a similar readiness for the learning task and performance expectation
- providing opportunities for identified gifted students to serve as resident topic or unit of study experts within the regular classroom setting
- academic and talent competition participation such as local, regional, state, or national contests in a variety of areas such as science fairs or other academic and fine arts competitions
- guidance and counseling sessions and activities to assist identified gifted students in planning their course selections for future academic and career pursuits specifically utilizing the EXPLORE assessment for 8th graders
- Duke University, TIP, Talent Identification Program for 7th grade students
- field trips for enrichment in areas not emphasized in the regular curriculum

High School Gifted Students Program Options:

- Advanced Placement Courses providing high school students the opportunity to receive college credit by examination as delineated by the Advanced Placement Program of College Board
- concurrent college enrollment for qualified students enabling them to concurrently take college course work while attending high school
- cross-grade grouping providing opportunity for a student to work in an advanced grade level setting with one or more students sharing a similar readiness for the learning task and performance expectation
- providing opportunities for identified gifted students to serve as resident topic or unit of study experts within the regular classroom setting
- academic and talent competition participation such as local, regional, state, or national contests in a variety of areas such as science fairs or other academic and fine arts

competitions including robotics team competitions

- guidance and counseling sessions and activities to assist identified gifted students in planning their course selections for future academic and career pursuits specifically utilizing the EXPLORE/PLAN/ACT and/or PSAT/SAT assessments
- field trips for enrichment in areas not emphasized in the regular curriculum

Confidentiality:

According to district policy, the disclosure of information contained in a student's educational record is limited except by prior written consent of the student's parent/guardian or the legally-eligible student or under certain limited circumstances as permitted by the Family and Educational Rights and Privacy Act. Records of placement decisions and data on all nominated students are kept on file for a minimum of five years or for as long as needed for educational decisions.

Qualifications and Responsibilities of Gifted and Talented Educational Program Staff

A teacher of the gifted and talented shall hold a valid Oklahoma Teaching Certificate appropriate to the certificate credential and grade level(s) included in the program.

All teachers whose duties include direct involvement with gifted/talented students shall participate in professional development, workshops, seminars, conferences, and/or college training designed to educate/assist them in the area of gifted and talented education.

Gifted and talented education program coordinators shall hold a valid Oklahoma Teaching Certificate. They shall also participate in professional development, workshops, seminars, conferences, and/or college training designed to educate/assist them in the area of gifted and talented education.

Responsibilities of School District and Local Board of Education in Providing for a Gifted and Talented Program:

The local Board of Education is responsible to provide gifted and talented educational programs for all eligible gifted and talented children who reside in the district. This differentiated education will include multiple programming options which shall be carefully matched with students' identified needs, interests, and abilities.

The district shall submit a Gifted and Talented Child Count, a Gifted and Talented Educational Plan Update, a Summary Budget, and a Gifted and Talented Expenditure Report to the State Department of Education by state determined deadlines each year.

Annual Evaluation of Gifted and Talented Program:

The local school district shall conduct an annual evaluation of the gifted and talented program. To aide in this evaluation, surveys shall be conducted of students, staff, and parents. The evaluation process will assess each component of gifted programming

education which will include, but will not be limited to:

- identification
- professional development
- curriculum
- instructional program
- program management
- evaluation process

Evaluation findings are to be compiled, analyzed, and communicated to appropriate groups. Results of the annual evaluation conducted by the district should be taken into consideration when devising program improvement plans.

Local Advisory Committee:

The Local Advisory Committee shall be appointed by the district Board of Education, and shall consist of at least three (3) but no more than eleven (11) members, at least one-third (1/3) of whom shall be selected from a list of nominations submitted by associations whose purpose is advocacy for gifted and talented children. The Local Advisory Committee shall be appointed no later than September 15th of each school year for two-year terms and consist of parents of children identified as gifted and talented and community members who may be, but are not required to be, parents of students within the district.

(70. O.S.1210.308A)

The first meeting shall be called by the superintendent or the superintendent's designee no later than October 1st of each year. At this meeting, the committee shall elect a chair and a vice-chair.

The Local Advisory Committee shall meet at other times during the year as necessary in meeting space furnished by the district. All meetings of the committee are subject to the provisions of the Oklahoma Open Meeting Act. The school district shall furnish staff which has training in gifted and talented education on the advisory committee.

The Local Advisory Committee shall assist in the formulation of district goals for gifted education, assist in development of the district plan for gifted and talented educational programming, and perform other advisory duties as requested by the Board of Education.

(70. O.S.1210.308A)

The school district may choose to expand the duties of a Curriculum Advisory Committee rather than create a Local Advisory Committee on education for gifted and talented children.

Districts utilizing the curriculum body shall appoint at least one member who is a parent of a child identified as gifted or is a knowledgeable advocate for gifted children.

(70. O.S.1210.308A)

Budget

District administrative personnel will compile and prepare the budget for gifted educational programming in conjunction with the superintendent and the Local Gifted Advisory

Committee. The budget will be compiled on forms required by the State Department of Education and will be submitted per the established guidelines. The budget will be approved by the Board of Education before filing with the State Department of Education.

Expenditures Report

An expenditures report for the previous school year will be submitted by the superintendent to the State Department of Education as required. This report will outline the expenditures made by the district for gifted and talented educational programming. The report will identify expenditures by major codes and program classifications pursuant to the Oklahoma Cost Accounting System.

Revised August 31, 2013

MEMO

To: Sean McDaniel, Superintendent *SM 8/30/13*
From: Jeff Woodard, Director of Bonds/Construction
Date: August 30, 2013
Re: Substantial Completion for Mid-High Renovation

Respectfully request that the Board discuss, consider, and/or act upon approval of the certificate of substantial completion for Horizon Intermediate (Mid-High renovation).

AW
8/30/13



AIA® Document G704™ – 2000

Certificate of Substantial Completion

PROJECT:
(Name and address)
Mustang Mid-High Renovation - 5th
and 6th Grade Center
430 Forster Drive
Mustang, OK 73064

PROJECT NUMBER: 1511E67/
CONTRACT FOR: General Construction
CONTRACT DATE: 4-26-12

OWNER:
ARCHITECT:
CONTRACTOR:
FIELD:
OTHER:

TO OWNER:
(Name and address)
Mustang Board of Education
906 South Heights Drive
Mustang, Oklahoma 73064

TO CONTRACTOR:
(Name and address)
Timberlake Construction Company, Inc.
P.O. Box 18297
Oklahoma City, OK 73154

PROJECT OR PORTION OF THE PROJECT DESIGNATED FOR PARTIAL OCCUPANCY OR USE SHALL INCLUDE:

The Facility of Mustang Mid-High Renovation for 5th and 6th Grade Center with the exception of Area 4 (as identified on the Construction Documents) and the exterior site work around the building.

The Work performed under this Contract has been reviewed and found, to the Architect's best knowledge, information and belief, to be substantially complete. Substantial Completion is the stage in the progress of the Work when the Work or designated portion is sufficiently complete in accordance with the Contract Documents so that the Owner can occupy or utilize the Work for its intended use. The date of Substantial Completion of the Project or portion designated above is the date of issuance established by this Certificate, which is also the date of commencement of applicable warranties required by the Contract Documents, except as stated below:

Warranty

Date of Commencement

MA+ Architecture, L.L.C.

ARCHITECT

BY

August 21, 2013

DATE OF ISSUANCE

A list of items to be completed or corrected is attached hereto. The failure to include any items on such list does not alter the responsibility of the Contractor to complete all Work in accordance with the Contract Documents. Unless otherwise agreed to in writing, the date of commencement of warranties for items on the attached list will be the date of issuance of the final Certificate of Payment or the date of final payment.

Cost estimate of Work that is incomplete or defective: \$50,000.00

See attached list of remaining portions that need to be completed.

The Contractor will complete or correct the Work on the list of items attached hereto within Thirty (30) days from the above date of Substantial Completion.

Timberlake Construction Company,
Inc.

CONTRACTOR

BY

DATE

8/20/13

The Owner accepts the Work or designated portion as substantially complete and will assume full possession at 8:00 a.m. (time) on Friday, August 16, 2013 (date).

Mustang Board of Education

OWNER

BY

DATE

8/30/13

This is a list of the remaining portions of the project that have not been reviewed or inspected.

- All of the exterior portions of the project, including all Civil work, has not been reviewed.
- All of Area 4 has not been reviewed.
- All of the Basement Area has not been reviewed.
- P.E. Gym 210 & Storage Room 206 has not been reviewed.
- All Corridor Floors has not been reviewed.
- 196 Classroom Floor has not been reviewed.
- 197 Classroom Floor has not been reviewed.
- 198 Classroom Floor has not been reviewed.
- 199 Classroom Floor has not been reviewed.
- 149 Classroom Floor has not been reviewed.
- 179 Classroom Floor has not been reviewed.
- 160 Classroom Floor has not been reviewed.
- 138 Classroom sink and counter has not been reviewed.
- 147 Classroom sink and counter has not been reviewed.
- 137 Classroom Kitchenette and bookshelf has not been reviewed.
- 136 Classroom bookshelf has not been reviewed.
- Janitor Closet 184A has not been reviewed.
- Corridor Door 174A (at classroom addition) has not been reviewed.
- Storage Room 183A Floor has not been reviewed.
- Kitchen Restroom 120 has not been reviewed.
- Kitchen Office 128 has not been reviewed.
- Electrical Closet 130 has not been reviewed.

Horizon Elementary Classrooms

Project Number: 1511E67

July 26, 2013

Present at Inspection: Jeff Woodard, Marcia Gallant, Josh Pendleton, Jay Crawford, Ryan Manning
 Note: All room numbers are based off of Architectural drawings.

RM #	ROOM NAME	DESCRIPTION	TIMBERLAKE COMMENT
ALL	General Notes	Remove debris from light fixtures	
		Clean light fixtures	
		Clean base	
		Fix drawer pulls in Teacher Cabinets	
		Clean up caulking at window sills	
		Install door stops	
		Emergency lights need power	
		Fix overspray of texture on block walls next to new walls	
		Clean existing adhesive and caulking from block walls	
		Adjust catch at Cubby doors to not rub on other door	
		Clean tack boards	
		Touch up paint at all door frames	
		Repaint all door frames	
		Cover all screw holes on outside and inside of all millwork	
		Adjust all millwork to make all doors/drawers level, reveals even, minimize reveals, and make drawer/door operation smooth.	
		Caulk all backsplashes to wall	
		Install corner guards	
		Fix scratches in millwork as marked	
		Patch holes @ cubbies below hooks	
		Clean up top of wall/ transition to ceiling grid	
		Clean tops of door frames	
		Install end cap at ends of markerboard map rails	
		Install missing screws in cubbies	
		Install buttons at upper cabinet bottoms to conceal screws of lip	
		Clean all glass	
		Install coat hooks at all teacher cabinets & cubbies	
		Clean all surfaces of millwork, including interior surfaces	

		Replace all new surface mounted conduit with wire mold as specified or cover all new surface mounted conduit with cover as shown in hand sketch detail provided to TCI. Contractor to notify Architect of method chosen.	
		Clean all millwork door corners to remove dark staining	
		Patch and paint walls as marked	
		Install room signage	
		Existing window sills to be cleaned and painted	
		Wood knots found in millwork are being reviewed against industry wood standard to determine if millwork provided is acceptable. Determination forthcoming.	
	BLUE POD		
	188 Classroom	Install catch in upper cabinet 3rd door from wall	
		Install light lens	
		Install PLAM finish on side of teacher cabinet	
		Replace ceiling tile above teachers cabinet	
		Replace damaged ceiling tiles near fire strobe	
		Install blank cover plates	
		Clean ceiling tile near sprinkler at cubbies	
	189 Classroom	Clean room	
		Install cover plates	
		Clean base	
		Fix light not working near window	
		Clean tackboard	
		Install mechanical cover floor grill	
		Re-sand & paint corner of room next to cubbies/ tack board	
		Clean up window caulking	
		Fix hole at lock on teachers cabinet	
		Fix screw hole edges at back of teachers cabinet	
		Finish hardware install	
	190 Classroom	Fix base between door & bookshelves	
		Clean room	
		Install silencers	
		Fix wall at electrical outlet next to wardrobe	
		Remove adhesive from top of wall next to window	

		Clean up tackboard	
		Patch wall above base between exterior wall and cubbies	
		Re-do bookshelf end panel near teachers cabinet	
		Adjust catch on upper cabinet - 3rd set from door- hard to open	
		Patch wall behind door - bad texture and exposed screws	
		Finish door hardware install	
		Replace ceiling tile that has chipped edge near exterior wall	
		Replace damaged floor tiles (2 found)	
191	Classroom	Put finish on end of teachers cabinet	
		Install flat file drawers	
		Fix base between teachers cabinet and accent wall	
		Fix scratch in teachers cabinet	
		Adjust catch at middle upper cabinet - door won't open	
		Replace base between door & cubbies	
		Replace ceiling tiles as marked (7 marked)	
		Replace damaged floor tiles (3 found)	
192	Classroom	Cover holes in cabinet below sink	
		Install shelf in lower cabinet	
		Install cover plate at box above counter	
		Patch hole in wall above counter	
		Fix scratch on first door above cubbies from door	
		Adjust catch to lock properly - 2nd set of doors	
		Install shelf in last cubby cabinet	
		Fix hot water to function properly	
		Replace discolored & chipped ceiling tiles (4 chipped tiles)	
		Replace damaged floor tiles (2 found)	
187	Science Classroom	Install lock catch in cabinet above cubbies	
		Intall missing sprinkler cover	
		Adjust flat file drawers to close properly	
		Remove paint from millwork	
		Clean ceiling grid at door	
		Fix hot water to function properly	
		Replace 3 missing ceiling tiles	
		Touch up paint above marker board	

		Fix gouges and cracks in cubby fronts	
		Fix base between angle wall and teachers cabinet	
		Replace damaged ceiling tiles (8 found)	
		Replace damaged floor tiles (4 found)	
194	Cart Storage	Remove tape from ceiling grid	
183	Electrical	Room not punched	
183A	Storage	Room not punched	
186	Work Room	Patch walls around millwork each side	
		Adjust millwork doors/ drawers to align	
		Fix 2 gouges in upper cabinet doors	
		Fix splice at upper cabinet	
		Feather wall behind base at existing pipe near sink and reinstall base	
		Caulk floor to clean out	
		Replace ceiling tile above door at closer	
154	MDF Room	Room not punched	
YELLOW POD			
201	Classroom	Cover screw holes in back of wardrobe cabinet	
		Clean file drawer fronts	
		Fix base on beige CMU wall and wall next to thermostat on wall	
		Clean ceiling grid near accent wall	
		Adjust/ replace base at cubbies	
		Replace damaged ceiling tiles (4 found)	
		Replace damaged floor tiles (1 found)	
200	Classroom	Remove tape from millwork	
		Finish end of student cubbies	
		Adjust door catch on 2nd door from accent wall - it does not open well	
		Repair 3 light fixtures that aren't working	
		Adjust sprinkler covers which are hanging down (2 found)	
		Adjust ceiling tile at sprinkler head	
		Replace chipped ceiling tiles (2 found)	

	Replace damaged floor tiles (17 found)	
	Replace missing ceiling tile	
	Fix wavy base between cubbies and accent wall	
	Clean ceiling grid near door	
	Adjust ceiling tile at sprinkler head near door	
196	Classroom	Adjust catch @ cabinet door - 4th & 6th door from angle wall & last catch Adjust cabinet doors to align Adjust ceiling tile at sprinkler near window Repaint accent wall Floor not punched Replace damaged ceiling tiles (9 found) Fix wavy base on angled wall near door Clean room
197	Classroom	Room not punched
198	Classroom	Room not punched
199	Classroom	Room not punched
RED POD		
177	Classroom	Fix nail hole issues at ceiling grid above sink Install door Install red accent floor tiles Remove tape from sink drain Adjust cabinet doors - 3rd bay from wall - hinge not on properly Adjust light lens covers near accent wall Adjust cabinet door catches - 1st bay from right end, 2nd door Adjust ceiling tile at sprinkler cover near cubbies & towards wall Replace other ceiling tile at sprinkler by cubbies and at sprinkler by teachers cabinet Clean inside millwork at sink and counter Fix light fixtures that do not work (2 found) Clean up joint between ceiling grid and top of wall at perimeter of room Cover holes below coat hooks

175	Classroom	Install electrical cover plate near cubbies Adjust catch on 1st full cabinet from wall Address cable outlet above marker board Install screws at side wall of cubbies Cover holes below coat hooks Install door
252	Alternate Classroom	Install window sill trim pieces Install end panel finish at bookshelves Clean flat file drawer fronts Adjust electrical outlet cover plate above marker board Adjust catches on 2nd & 5th full cabinet sets to open better Install screws at cubbies side panel Fix floor tile joints in front of cubbies Clean ceiling grid by tack board Adjust ceiling tile at sprinkler by tack board Replace damaged ceiling tiles (4 found) Remove construction filter Adjust light trim near marker board Adjust ceiling grid splice near marker board Adjust floor tiles joint near wall furr out Adjust light lens cover by wall furr out Clean smudges from all light fixtures
257	Alt Storage Room	Replace missing ceiling tile Remove construction filter Clean brick wall Replace damaged ceiling tiles (5 found) Fix hole in door Remove paint from door frame Clean supply air grill
251	Alternate Classroom	Fix lights that aren't working (3 found) Adjust catches on 1st full, 4th, and 6th cabinets Finish bookshelf end panel

		Address window sill trim at both windows	
		Clean ceiling grid near supply air near window	
		Replace damaged ceiling tiles (7 found)	
		Replace ceiling tiles with red paint on them over teachers cabinet (2 found)	
		Clean light fixture & ceiling grid at marker board & tack board	
		Replace damaged floor tiles (1 found)	
		Install thermostat at correct height	
253	Alternate Classroom	Adjust catch on 2nd and 5th cabinet from left	
		Adjust all cabinet doors to align	
		Install catch on cabinet door, 1st from left	
		Install screws at side of student cubbies	
		Fix lights that don't work (3 found)	
		Install light lens	
		Address window sills at both windows	
		Fix right side of bookshelf, 3rd shelf ends	
		Fix chipped corner @ top of bookshelf	
		Reinstall base at bookshelf	
		Clean dirt and smudges from light fixtures	
		Adjust ceiling tiles at sprinkler near door	
		Replace damaged ceiling tiles (14 found)	
		Clean ceiling grid at sprinklers at tackboard	
		Adjust light fixture at cubbies	
254	Alternate Classroom	Adjust catch at 1st full door	
		Adjust cabinets for alignment	
		Install missing cabinet door	
		Fix cubbie vertical joints - (2 locations found)	
		Patch wall above thermostats	
		Fix top of bookshelf, which is bulging	
		Adjust sprinkler cover near teachers wardrobe	
		Address window sill trims	
		Fix ding on 2nd flat file drawer	
		Adjust light fixture trim in middle of room	
		Replace base at cubbies	
		Replace damaged ceiling tiles (8 found)	
		Install missing screws at door hinges	

258	Alt Storage Room	Storage Room not punched	
147	Classroom	Fix scratch at front of cabinet door Adjust catches on 3rd, 4th, and 6th cabinets from door Sink counter not punched Install faucet and 2 drawers at counter and shelf Fix leak above ceiling near counter & replace water damaged tiles Provide smooth finish on sink cabinet Paint column Install shelf at half upper cabinets at cubbies Replace ceiling tile at column for better fit Caulk gap to wall at cubbies Touch up paint/conceal screws at top of wall/ ceiling grid perimeter of room Fix leak above teachers cabinet and replace ceiling tile Install accent floor tiles Repaint accent wall Replace damaged floor tiles (7 found) Replace damaged ceiling tiles (5 found) Fix lights not working properly (2 found) Install door	
146	Classroom	Install door Install accent floor tiles Install screws at cubbies side Install shelf at cabinet next to wall Repaint accent wall Adjust catches on two cabinets nearest windows Paint wall above cubbies in corner Install missing ceiling tiles and grid (4 tiles found missing) Caulk floor tile to window sill Fix wavy base near window Replace 3 missing tiles above window Repaint tack board wall Fix base next to bookshelves Remove paint from top of bookshelves Replace damaged floor tiles (8 found)	

		Replace damaged ceiling tiles (8 found)	
		Install screws at back of cabinet, 2nd from window	
		Install stainless cover plate at accent wall	
		Remove construction filter	
		Fix corner of cubbies near window	
149	Flex Classroom	Room not punched	
179	Classroom	Room not punched	
	Green Pod		
202	Classroom	Attach first cabinet door to hinge	
		Adjust all cabinet catches to open easily	
		Fix rough edges @ cubbies	
		Install electrical outlet in cubby	
		Install missing finish at cubby shelf 4th from door	
		Clean paint from millwork	
		Tighten screws/ install screws on cubbies	
		Fix chips on bookshelf and teachers cabinet	
		Replace missing ceiling tile	
		Mill finished data cover plate to receive paint	
		Patch hole at top of wall at window	
		Replace damaged floor tiles (2 found)	
		Replace damaged ceiling tiles (4 found)	
		Install transom at door	
151	Classroom	Adjust catch on cabinet next to column	
		Repaint column	
		Replace ceiling tiles at column	
		Remove items from millwork	
		Stain missing at cubbies near door	
		Clean paint from electrical outlet near cubbies	
		Fix base at cubbies	
		Install missing screws at cubbies and cabinets	
		Fix scuffs on cubbies	
		Fix wavy base at angled wall	

		Reinstall missing ceiling tiles (2 found)
		Replace damaged floor tiles (2 found)
		Replace damaged ceiling tiles (7 found)
		Fix rough edge at end of cubbies near column
		Install missing screws in door hinges
		Address kick plate
152	Classroom	Finish end panel @ cubbies
		Replace missing ceiling tiles (3 found)
		Finish teacher cabinet door
		Install missing light
		Clean up paint transition between green and beige paint
		Install coat hook at teacher cabinet
		Clean ceiling grid at sprinkler near marker board
		Replace damaged ceiling tiles (11 found)
		Clean green paint from floor near accent wall/ teacher cabinet
		Fix floor joint near markerboard
		Fix dent in ceiling grid at return air
		Make strike plate flush
203	Classroom	Remove tape from cubbies
		Install electrical outlet at cubbies
		Remove debris from room
		Adjust door lockset
		Replace missing ceiling tiles
		Fix leak above ceiling & replace ceiling tile
		Address window sill
		Replace damaged floor tiles (6 found)
		Replace damaged ceiling tiles (2 found)
		Fix base splice behind door
		Address door transom
204	Classroom	Address door transom
		Fix door hardware
		Clean green paint from floor and millwork
		Reinstall base at cubbies
		Install missing light, ceiling tiles & grid

		Install electrical receptacle	
		Reinstall corner base at small furr out	
		Adjust door life frame	
		Clean paint from floor tile	
		Clean room	
		Replace damaged ceiling tiles (14 found)	
163	Classroom	Install catch at 1st upper cabinet next to door	
		Replace ceiling tile @ column	
		Repaint column	
		Replace floor tiles at air grill	
		Anchor tackboard to wall	
		Install water to sink	
		Fix wavy base next to bookshelves	
		Fix leak above ceiling and replace water damaged tiles (2 found)	
		Install silencers at cabinet below sink	
		Fix melamine at inside of teacher cabinet	
		Remove protection from drain	
		Clean counter	
		Install trim in corner at ceiling at door	
		Caulk tile to column	
		Replace damaged ceiling tiles (2 found)	
		Fix floor tile joints at corner at door	
		Address transom	
		Fix thermostat read out	
162	Classroom	Install missing wall base	
		Fix plumbing for water to sink to function properly	
		Fix rough cabinet door edge	
		Patch holes at door frame transom	
		Reinstall moved ceiling tiles	
		Patch floor by window	
		Fix edge of teacher cabinet door	
		Install light switch	
		Install sprinkler cover	
		Replace damaged ceiling tile (1 found)	
		Clean up paint transition near sink	

161	Classroom	Install missing ceiling tiles Adjust catch on 1st cabinet from door Install sprinkler cover Adjust sprinkler cover near door Adjust center light fixture Fix bent ceiling grid at window Fix bent chalk tray Touch up scrapes at ceiling grid at light near window Replace damaged floor tiles (5 found) Replace damaged ceiling tiles (1 found)
160	Classroom	Floor not punched Clean room Fix leaks above ceiling and replace water damaged tiles (10 found) Repaint accent wall corner/ paint color transition Repaint column Install light switch Address transom Fix scratch in door
159	Classroom	Address light switch Remove tape at accent wall corners Install ceiling grid/ tile at teacher cabinet Paint conduit and box at data boxes (3 locations found) Reinstall moved ceiling tiles (2 found) Fix crack in cubby shelf front Replace damaged floor tiles (6 found) Install sprinkler covers (2 found) Clean ceiling grid near sprinkler cover near door
158	Classroom	Fix rough door edge Adjust catch at 1st full door cabinet Reinstall moved ceiling tiles (2 found) Adjust flat file drawers - they were installed crooked Install missing sprinkler covers (3 found) Replace rough ceiling tile near TV mount

	Finish waxing floor near exterior exit door	
	Replace damaged floor tiles (2 found)	
	Fix and install tiles around floor clean out near kitchenette	
	Fix and install base near washer and dryer alcove	
	Clean tackboard	
	Remove existing caulking and repaint accent wall	
	Paint wall near ceiling and washer box in washer and dryer alcove	
	Paint existing junction box and install covers	
	Adjust latch on far east cubby door	
	Fix door edging on cubby 3rd from east	
	Fix split in support face on cubby 3rd from east	
	Install missing coat hooks in cubbies (14 found missing)	
	Clean dust off teachers cabinet	
	Install closer bumper on east door of teacher cabinet, as it is missing	
	Clean spackle from east door of teacher cabinet	
	Install proper door hardware to seal exterior exit door from outside	
	Patch and paint exterior exit door and frame	
	Install fire sprinkler covers	
	Fix leaks above ceiling and replace water damaged ceiling tile (3 found)	
	Replace damaged ceiling tiles (2 found)	
	Adjust door latching hardware at classroom entry door	
	Install base within the closet	
	Clean and wax floor in closet	
	Caulk southeast wall corner in closet	
	Paint existing clothes rod support	
	Paint walls to existing millwork	
	Install light switch	
	Clean overspray of spackle and paint from existing millwork	
	Touch up all walls	
136	Classroom	
	Bookshelf not punched as it was covered in dirt	
	Adjust door latching hardware at classroom entry door	
	Replace damaged floor tiles (4 found)	
	Fix base at southwest corner	
	Fix base at window base	
	Fix caulking at window head	
	Fix gasket at window	

	Clean tack boards	
	Install cover on north wall junction box	
	Repaint accent wall	
	Install cover on junction box above marker board	
	Install cover for fire sprinklers	
	Fix leaks above ceiling and replace water damaged ceiling tile (1 found)	
	Replace damaged ceiling tiles (4 found)	
	Clean shelves of cubby cabinets	
	Fix broken door on cabinet, 2nd door from west	
	Fix gap between shelf and cabinet, 5th & 6th cubbies from west	
	Fix splintered back panel on far east cubby	
	Fill holes under coat hooks in cubbies	
	Fix split support under cabinet between 12th and 13th cabinet from east	
	Touch up scratches on east door of teacher cabinet	
134	Flex Classroom	
	Fix base under teacher cabinet	
	Fix base at door entry	
	Replace damaged tiles under markerboard (1 found)	
	Fix leaks above ceiling and replace water damaged ceiling tile (4 found)	
	Install fire sprinkler covers	
	Clean dirty ceiling tiles	
	Adjust door latching hardware at classroom entry door	
	Repaint accent wall	
	Install covers on junction boxes on accent wall	
	Clean spray insulation from west wall and repaint	
	Clean marker and tack board	
	Install shelf in north cubby cabinet	
	Install coat hooks at cubbies	
	Fill holes under coat hooks	
	Clean splatter from south face of teacher cabinet	
	Cover holes at side & back of teacher cabinet interior	
	Fix edge banding at lower north face of interior of teacher cabinet	
	Clean sink and vanity	
	Fix hot water, which does not work well	
	Fix far right vanity drawer from hanging up during opening	
	Seal backsplash to counter and wall	
	Touch up splatter and scratches on vanity door faces and side panel	



**Horizon Elementary
Media Center - Administrative Area**

Project Number: 1511E67

August 15, 2013

Present at Inspection: Heath Tate		
Note: All room numbers are based off of Architectural drawings.		
RM #	ROOM NAME	TIMBERLAKE COMMENT
142	Storage	Touch up paint on door frame Provide blank covers on existing electrical boxes recessed in north wall Paint wall patch on south wall near electrical panels and on north wall behind electrical panel Paint east corner of wall at caulking line
145	Media Center	At east pair of doors: Install center mullion Provide rubber transition strip/threshold at flooring material change Install key cores Clean doors/window frame, both sides CMU bases at east windows shows the cut end of the burnished block. This was identified as incorrect at previous construction meeting and is to be corrected. This happens at all columns. One can light at NE corner not installed. Near east entry. At NE corner wall paint has been over sprayed onto ceiling grid. This is near the Media Desk. Red paint drips on east wall near south corner. Touch up paint on this wall. East wall at south corner: Trane sensors are not cleanly installed. Sealant was used under sensors. Sensors are not level. Drywall needs to be patched and sensors installed level. Near SE corner where stainless steel corner guard is applied: trim silicone at stainless steel corner guard and touch up paint on wall where sealant has pulled paint loose. South Wall: Paint overspray on ceiling grid needs to be removed and cleaned Provide cover plate on co-ax outlet Horizontal scratch in drywall was textured and painted. Repair wall, touch up and texture to match surrounding wall.

	At SW corner CMU wall needs to be repaired and painted. CMU block at ceiling is damaged and does not provide a seal at the exterior wall.	
	West Wall:	
	Aluminum frames at south exit are not correctly installed. Frame bows away at window sill.	
	Window sills are not sealed to the walls/all window sills	
	At south end of window frame, gyp board at sill does not match plane of CMU wall. This connection needs to be addressed.	
	Alum break metal at window sills in some areas bows away from frame. These need to be installed properly	
	Touch up paint several locations above windows and at north CMU wall	
	At north door, closer box is scratched and damaged: replace/clean door and glass	
	North Wall:	
	Touch up paint above window at west end	
	Clean windows to remove construction dust from glazing seals	
	At east end provide cover plate at wall outlet	
	At window to office: touch up paint at window opening	
	At office wall: provide outlet cover at wall box	
	At office wall corner: clean paint off of stainless steel corner guard/clean sealant off too	
	Clean door/window frame at office/clean wall opening at office door and window - touch up paint	
	Seal gaps between window frame and wall	
	Touch up paint scratches on door frame into Storage Room #144	
	Storage Room Door #144 does latch as it closes under it's own weight	
	Ceilings:	
	Paint sprinkler head covers to match ceiling: entire room	
	Paint supply and return diffusers and grills to match the ceiling	
	Ceiling tile damaged over media desk near fire strobe	
	Clean can lights in red furr-down to remove fingerprints and construction dust	
	Clean all ceiling grid to removed construction dust and paint overspray - entire room.	
	Adjust sprinkler head covers at red furr-down so they are flush with furr-down.	

	2x2 lights in green ceiling furr-down need to be adjusted to sit level in gyp board openings	
	At 2x2 lights in green furr-down gyp board edge returns at lights are to be painted green	
	Clean 2x4 lights entire room	
	Yellow ceiling grids: silver brackets need to be painted to match	
	Touch up paint on green furr-down to cover damaged areas	
	Touch up paint/clean at green furr-down and ceiling grid connection	
	Floors:	
	Replace carpet tile near computer desk which has paint sprayed on it.	
	South computer desk, east end.	
	Clean construction dust off carpet: entire room	
	Clean wall base to remove construction dust	
	At the north wall - center of wall - there is a gap between the floor tile	
	Media Desk:	
	Provide outlet covers where not provided by MPS IT	
	At west end of media desk on the front side a shim is visible and needs to be trimmed so it is not visible	
	Provide metal trim around book drop	
	Computer Desks:	
	Provide base at the columns	
	Wall covering at column overlaps onto desk: unfinished column is visible at table edge - both columns	
	Clean glue off of wall covering - both columns	
	Seams at countertops have construction dust - clean/close gap	
	Escutcheons loose at 3-form panel supports	
	Provide outlet covers under countertops where not provided by MPS IT	
	Underside of counters damaged where convenience holes are cut: worst location is north desk, north side at center of desk. All locations need to be addressed.	
	Clean pencil marks off countertops at convenience hole locations	
143	Office	
	Provide closer cover on door	
	Clean door frame at floor	
	Wall base at door is coming loose	
	Clean window frame	

144	Storage	Install wall base entire room Touch up wall paint at door head Repair wall damage near E corner Remove construction filter at return air grille Touch up NE wall to cover marks on wall Touch up entire west wall
101	Vestibule	Touch up north wall near corner guard Touch up south wall - several locations Clean all door and window frames to remove construction dust Provide wall outlet covers where not provided by MPS IT Remove plastic from door closers Remove pencil marks from Door #101C where hardware was installed Finish install of automatic door closer Clean tile Replace damaged ceiling tile near ext. doors Adjust sprinkler head cover near Door #102A
102	Reception	Clean door frame and closer at Door #102A Clean all window frames to remove paint Remove construction filter Provide transition strip at floor at Door #102B Clean wall base Clean aluminum fillings at Door #102B - at floor Bottom of Reception Desk is damaged near east wall - repair/shims are visible between millwork base and carpet. Damage to west gyp board wall near south corner. 2 locations - repair and paint. Damage to west gyp board wall near middle of wall at base. Resilient base at red wall covering, west side, is pulling away from wall Install corner guard at west corner of red wall covering 2x2 light in ceiling does not sit flush in ceiling Adjust can lights so they are flush with ceiling: several lights Touch up paint on frame of Door #116A at edge of frame Clean paint off of wall outlet on east wall Base cabinets east wall: Repair screw holes inside cabinet (2nd from north)

		Middle set of drawers: 2nd drawer from top catches as it opens	
		Clean black marks off of south pair of doors - inside face	
		South door hinges overhang on inside edge; these hinges will fall over time. Hinges are to be properly supported.	
		Short 3-form panel at east side of millwork is loose	
		Clean under counter top at desk-east side	
		Bottom two drawers at desk do not open full depth to match other drawers	
106	Nurse	Touch up paint at SW corner	
		Replace stained ceiling tile near cabinets	
		Remove construction materials from center cabinets/intermediate shelf not installed	
		At upper cabinets - south cabinet has yellow staining on movable shelf - replace	
		Base cabinets:	
		Clean under sink space	
		Repair damage to lower cabinet	
		Provide covers around plumbing line penetrations	
		Replace countertop: countertop not square with walls/sealant used to fill gaps in not acceptable	
		Provide intermediate shelves which are not installed	
		Clean base	
		Seal VET at door frames to fill gaps	
		Sealant at window frames near sills is poorly done	
		Clean bugs out of light fixtures	
		Clean ceiling tile grid between light and fire alarm	
105	Storage	Clean light	
		Clean east wall to remove stain	
104	Rest Room	Clean tile wall to remove construction dust	
		Clean toilet seat to remove marks	
		Touch up paint on door frame	
103	Corridor	Ceiling tile at center of corridor occupancy sensor doesn't sit square	
		Clean toping compound off of ceiling grid at gyp board furr-down	

107	Office	Door hardware is not flush with edge of door. The mortise catches on the door strike. Touch up paint at SE corner of room Touch up paint at column furr-out at base Ceiling grid has a gap at the wall in the SW corner
108	Conference	Remove marks on door Replace dirty ceiling tile at east wall that does not sit in grid properly Finish installation of floor box
112	Corridor	Touch up paint on Door frame #112A/damage to wall beside door to be repaired Touch up paint at one spot on the north wall approx 10' from Door #112A
113	Rest Room	Clean walls Remove pencil lines over mirror Adjust sprinkler head cover so it sits flush against the ceiling
114	Rest Room	Touch up paint at door frame Remove pencil lines over mirror Clean walls
110	Break Room	Edge of door damaged at hinge side bottom of door Seal VET at door frames to close gap
116	Work Room	Upper cabinets east wall: 4th cabinet from south: damage to side panel needs to be repaired Provide cover plate at wall box - north wall Inside Door #115B: door lite has a splinter on the door trim East lower cabinets: drawer catches - 3rd from north Remove stickers inside all lower cabinets on shelves Door #116A: touch up door frame paint and seal VET to remove gaps between frame
115	Vault	Paint inside of vault frame

108	Office	Outlet cover on east wall doesn't cover hole in wall Touch up paint over door Touch up paint for sealant at windows near the sill	
111	Storage	Damage to face of door Top of door frame at hinge side	
117	Office	Couldn't inspect - door locked	
118	Conference	Touch up paint near light switch - 2 spots on wall Touch up paint around door frame on wall Remove construction filter on return air diffuser Touch up paint on north wall at ceiling Replace stained ceiling tile at NE corner Replace dirty ceiling tile near supply diffuser Adjust sprinkler head cover near door	
119	Office	Touch up wall paint around door frame/clean frame on corridor side at floor Touch up paint SE corner above floor base Quad outlet cover on west wall doesn't cover hole in drywall	
120	Corridor	Clean frame at Door #120A Touch up paint at Door #120A near ceiling Trim carpet at Door #120A around frames Provide transition strip at carpet and linoleum at Door #120A At Door #120A, seal wall to window frame all the way to the floor to close gap at base Replace stained ceiling tile at middle of corridor near light fixture Missing ceiling tile in front of Door #111A	
122	Men's Rest Room	Touch up paint at ceiling where it is sealed to the wall - entire room/touch up all ceiling spaces Access panels not installed: install and paint to match ceiling Adjust sprinkler head covers to be flush with ceiling Repair damaged ceiling above urinals Clean walls 1st toilet: cuts are visible in tile at plumbing penetration	

123	Women's Rest Room	Clean walls Install access panels and paint to match ceiling Light over sink not installed properly Repair damage to ceiling over HC stall Replace cracked tile on north wall at water spigot Remove stickers from toilet partitions 3rd stall from south: tile behind toilet is cut too large to be covered by plate where pipe comes out of wall
168	South Men's RR	Clean walls and ceilings to remove construction dust Install metal transition threshold strip at floor material change Light installed too close to wall over sink Pencil lines over mirrors and at overhead brace Adjust sprinkler head covers 1st toilet stall door swings closed instead of open NW corner: tile not grouted at corner Hand Dryers not working
176	Storage off RR	No base installed Install access panel in gyp board
169	Faculty Rest Room	Clean entire room
170	South WRR	Finish tile repair Install metal transition threshold strip at floor material change Install access panels and paint to match ceiling Most toilet stall doors swing close instead of open Cut tile visible behind HC toilet Clean entire room Hand Dryers not working
171	Faculty Rest Room	Clean room Touch up paint on door frame Dark grout tile joints should not be extended into white tile
140	Cafeteria	Clean stains off of cast stone caps/all columns

	Clean glue off of wood laminate panels: 2nd column from north on east side	
	All can lights to be mounted flush with furr-down	
	Touch up and clean red wall covering at east side	
	Touch up paint foam roof insulation SW corner	
	Clean base and floor	
	Paint sprinkler head covers in gyp board clouds to match cloud	
	Remove sticker from 2nd column from south on west side/outlet cover doesn't cover hole in CMU base	
	Clean paint off of 3rd and 4th column from south on west side	
	Seal all pipe penetrations through furr-down and paint to match	
	Touch up red cloud at north side	
	Where light fixture cables penetrate the gyp board clouds, provide protection to keep from damaging clouds	
	it does not appear that the light fixtures are hung level. Check and adjust if necessary	
	All unpainted sprinkler piping is to be painted	
	Install speaker enclosures	
	Adjust all sprinkler covers to be flush with gyp board ceilings	
	Floor cannot be completely inspected as it is half covered	
	All red welded seams need to be inspected. Where the red seam bleeds over onto the white linoleum the floor will need to be cleaned or changed to keep the red lines straight and consistent	
126	Serving Line	
	At ceiling overhead grilles paint support channels to match wall	
	6" resilient wall base is pulling away from walls all around room. Re-apply at wall base	
	Clean entire space	
	Touch up paint on south wall to hide marks on wall: in several places	
	Touch up paint at door frame/touch up paint above door on cafeteria side of door	
	Adjust sprinkler head covers	
	Touch up paint on north wall at openings to Kitchen	
	Replace stained ceiling tiles	
	Replace damaged ceiling tile at opening to Kitchen	
	Paint base of CMU at west opening to Kitchen where no base is present	

125	Dish Return	Replace damaged ceiling tiles Replace damaged and chipped tile at opening to serving lines Touch up paint over coiling dish return door Clean or replace dirty HVAC grilles in the ceiling
127	Kitchen	Replace stained ceiling tiles west side of Kitchen hood/and north side of hood One light fixture is missing lens diffuser and light bulbs At center opening to Kitchen and Serving Lines: forstone rough area of concrete where inoleum was cut around Kitchen equipment not completely installed
132	Kitchen Storage	Ceiling tile missing Clean light fixtures Remove construction filter Adjust sprinkler head covers
131	Teacher Dining	Clean entire room New counter top installed. Backsplash not completely installed VCT not cut around north wall very cleanly: redo at stainless steel wall cover Stained ceiling tile at sprinkler head Missing sprinkler head cover Air diffuser at north wall has paint chipped
120	Kitchen Restroom	Room not punched.
128	Kitchen Office	Room not punched.
130	Electrical Closet	Room not punched.

Horizon Elementary
Corridors - Remaining Classrooms - Storage - Closets

August 15, 2013

Project Number: 1511E67

Present at inspection: Josh Pendleton

Note: All room numbers are based off of Architectural drawings.

Although some flooring notes have been provided, all corridor floors have not been officially punched.

RM #	ROOM NAME	DESCRIPTION	TIMBERLAKE COMMENT
ALL	GENERAL NOTE	Clean base	
		Paint transom screws to match frames	
		Install seams of all flooring	
		Clean and wax all flooring	
		Touch up paint on door frames	
		Install end caps for wall tack strips	
		Clean off exposed silicone from corner guards	
		Touch up all ceiling tiles that have scuffs, scraps or dirt	
		Clean all ceiling grid of grease and fingerprints	
		Clean corner guards of fingerprints and overspray paint and caulking	
		Clean tile floors	
		Replace door transoms at doors with gap at transom head	
		Clean cast stone and block at columns near cafeteria	
		Clean exit signs	
		Install base	
		Remove black film from tops, bottoms and edges of corner guards	
		Clean all ceiling grid of grease and fingerprints	
		Accent floor joints to be welded	
		Clean dust from all walls	
		Paint fire sprinkler covers at accent color ceilings	
135	Corridor	Floor has not been punched	
		Touch up paint between Door 136A and 137A on accent wall	
		Fix base pulling away from wall at jamb of door to Flex Classroom 134 and Classroom 138.	
		Fill hole in drywall near A4 sign	
		Paint head at entry to Corridor. Remove existing caulking from lintel.	
		Touch up all ceiling tiles that have scuffs, scraps or dirt. (7 found)	

139	Vestibule	Install light switches/empty J-boxes found Floor has not been punched Paint south wall dirty spots near base Clean paint from aluminum frames Clean doors and glazing Adjust interior doors to close properly Re-texture south wall (texture does not match other) Adjust jamb weather seal at interior doors Install door opener
121	Corridor	Install far east diamond accent Floor has not been punched Touch up ceiling grid and ceiling tile near exit sign east entry Remove expose caulking at corner guards at Corridor #135 entry Touch up paint at Faculty Dining door frame Fill gap at head of Faculty Dining door Replace water damaged ceiling tiles: 2 found Touch up door frame at door to Storage #156 Touch up Door #156 Touch up furr-down of east angled wall Replace transom due to gap at transom head
	Column R8, 17	Fix broken tile and top of south face Fix laminate corner at east face Fix and clean laminate at north face
	North Wall Near Kitchen and RR	Paint steel channels at frame of rolling doors Touch up scratches on door and frame at Door #126B Touch up and install screws at dish return window head Touch up and clean tile trim at east drinking fountains Patch linoleum floor at east drinking fountains Floor is skewed from what is shown on Sheet A701 Far west diamond accent is not installed. Correct. Clean all tile at RR entry Touch up door frames for restrooms (both)

	Install metal transition threshold strip at floor material change at RR entry and drink fountains	
	Fix base at west entry, west end of west drinking fountains	
	Touch up ceiling at entry to Counselor's Offices	
	Touch up aluminum frame of door 120A	
	Patch wall next to electrical outlet near Counselor entry door	
	Door #102B: clean frame, touch up caulking at door head, fix base at jamb, touch up frame	
	Touch up and clean doors and frames at Door #101C	
	Clean linoleum floor at Door #142A base	
	Install corner guard near Door #101C, south wall	
	Fix paint at base at angled wall south end	
155	Floor has not been punched	
	East Wall:	
	Clean column finishes	
	Adjust and clean ceiling tile at fire sprinkler head between east columns	
	Paint steel channels at overhead coiling door	
	Touch up ceiling tile with fire sprinkler on south side of coiling door	
	Corner guard near Corridor #155 not all the way to ceiling, extend	
	West Wall:	
	Touch up angled ceiling tile above map rails	
	Touch up dented and scratched door frame at Classroom #150	
	Clean floors and seams at accent bands	
	Floor:	
	Clean up linoleum floor as marked by tape	
	Touch up rolling door emergency pull	
148	Floor has not been punched	
	Floor:	
	Address accent strips as marked by tape	
	Clean up seams, patch holes at seams	
	Touch up stained, marked and scuffed ceiling tiles	
	West Wall:	
	Address back edge of columns near media center glazing	
	Need threshold at Media Center Door #145A	
	Repaint inside corner at south end of north column	

		Touch up Door #145A	
		Clean glass, frame and caulking of Media Center windows	
		Touch up aluminum frame gaps and scratches	
		Touch up wall and ceiling grid at west wall near coiling door north side	
		East Wall:	
		Touch up rolling door emergency pull	
		Touch up wall around electric coiling door open switch	
		Repaint door frame Classroom #149	
		Fix wood door kick at bottom hinge, Classroom #149	
		Touch up south wall near cafeteria marked ceiling grid and wall	
		Clean up connection of corner guard at Corridor #148 and Corridor #165 connection	
		Clean up paint & caulking from edge of corner guard at corner of Corridor #148 and Corridor #166	
		Fix top of wall near F.E.C.	
166	Corridor	Floor has not been punched	
		Northwall West to East:	
		Fix base (wavy near west corner)	
		Repaint door frame of MDF room	
		Fix wall base east of MDF door	
		Fix gap in between base and wall between doors to MDF and CR #151	
		Fix wall base east of CR Door #152	
		Repaint door frame CR #151	
		Fix base between Doors CR #151 and #152	
		Repaint frame Door #152	
		Clean caulking from corner guard edge near east angled wall	
		Angled Wall:	
		Fix wall base pulling away from wall	
		Floor at corner to be patched	
		Touch up door frame to Teacher's Work Room	
		South Wall East to West:	
		Install wall base	
		Touch up Frame #260A heavy paint	
		Clean up green paint over spray on frame to CR #205	
		Touch up top of Door #205A	
		Touch up door near bottom hinge at Door #204A	

		Touch up paint on frame at Door #203A	
		Touch up bottom of corner guard near Door #202A	
		Touch up Door #C4 near bottom hinge	
		Touch up paint on frame at Door #202A	
		Need corner guards at west corner of Door #202A	
		Corner guard needed at west end of map rails	
		Fix ceiling tile at west exit sign	
208	Corridor	Floor has not been punched	
		Install Base	
		Seam floor joints	
		Touch up overspray paint on frame at Door #259A	
		Transom too short on frame at Door #259A	
		Caulk around FEC	
		Touch up paint on FEC wall, near FEC	
		Clean dirt off wall (angled wall going to PE Gym)	
		Replace PE Gym door with maple doors	
		Put block filler on CMU walls behind Drinking Fountain	
		Touch up paint on frame at Door #210A	
		Touch up CMU wall at frame at Door #210A	
		Clean plastic from Drinking Fountain, clean Drinking Fountain	
		Paint door head above Door #209A	
		Touch up CMU wall paint	
		Fill CMU wall budge and caulk on north CMU wall	
		Address J-box on north wall	
		Touch up holes and scratches on Door #208A	
		Touch up frame at Door #208A	
		Touch up frame and door at Door #209A	
		Address J-box under thermostat	
		Water damaged ceiling tile above door to PE Gym	
		Center exit sign above Door #208A	
		Cover box east of Storage Door #164A	
		Fix fire sprinkler head leading to Competition Gym	
165	Corridor	Floor has not been punched	
		Remove protective cover from corner guard at Door #147A	
		Install base	

		Fix 3 scuffed and stained ceiling tiles above Door #147A	
		Replace Door #147A	
		Repaint all frame at Door #147A	
		Wall texture scrap near Exit door switch south wall	
		Touch up paint at corner trim at Boy's RR entry	
		Replace stained ceiling tile near ceiling mechanical unit	
		Touch up ceiling grid at Boy's RR entry head	
		Clean aluminum frame and glass at exit door	
		Flush up fire sprinkler over at Door #146A	
		Fix flooring as it connects to aluminum exit frame entire length of frame	
167	Corridor	Floor has not been punched	
		Clean floor	
		Touch up door frame to Faculty RR #169	
		Touch up scuffed ceiling tile above RR#169	
		Touch up ceiling grid between faculty RR and Girl's RR door	
		Touch up paint and tile trim, entry head and Girl's RR entry	
		Fasten base at entry to Girl's RR	
		Clean and install drinking fountains and tile	
		Fix ceiling grid in drinking fountain alcove at back wall	
		Touch up scuffed tile above drinking fountain	
		Touch up scratches and dings on Door #172A to Mechanical Room	
		Touch up frame Door #172A	
		Touch up paint at inside corner at Door frame #172A	
		Install corner guards at outside corners of #172A	
		Replace ceiling tile (water damage) at angled wall near #172A	
		Touch up ceiling tiles above and left of FEC	
		Clean FEC and paint	
173	Corridor	Floor has not been punched	
		Paint door and frame #173A	
		Install base on south wall and angled wall	
		Address connection of flooring to #173 Door frame	
		Repaint east end of south wall near Door #173	
184	Corridor	Floor has not been punched	
		Install Base	

		Repaint door frame to Room #184A Janitor and #171 Faculty RIR	
		Patch dent in wall under electrical outlet near #171A	
		Install corner guard on wall corner across from #184A	
		Touch up paint over spray on ceiling grid above Door #184A	
		Touch up scuffs on Doors #171A and #184A(a)	
		Clean stains from flooring	
		Repaint wall at corner of Corridor #184 and Corridor #174	
		Touch up paint on Frame #183A and inside corner	
		Install corner guards at Door #183A	
		Fix gaps in ceiling grid near Door #183A	
		Clean tile at drinking fountains	
		Add corners at tile trim at drinking fountains	
		Touch up paint at edge of drinking fountain tile	
		Remove plastic coating from drinking fountains and clean	
174	Corridor	Floor has not been punched	
		Install Base	
		Door #179B:	
		Patch hinge connections on doors	
		Touch up door frame on all sides	
		Add corner guard	
		Fill hole in wall behind door handle. Install stop.	
		Clean door hinges	
		Fix 4 light fixture lenses	
		Door #179A:	
		Install corner guard both ends of door	
		Clean door frame of dust	
		Touch up wall at ceiling grid west of Door #179A	
		Touch up bottom of accent wall at Door #175A and #177A	
		Replace door with maple door	
		Touch up ceiling tile near west fire alarm strobe above Door #175A	
		Repaint frame on Door #177A	
		Clean door glass	
		Clean sealant from corner guard near Door #177A	
250	Corridor (Alternate)	Floor has not been punched	
		GEN NOTE: Clean grilles above doors	

	Install Base	
	Door #174A not punched (was being worked on)	
	Repaint frame #258A	
	Touch up Door #258A	
	Clean and adjust outlet west of Door #258A (sticking out from wall)	
	Corridor is missing accent bands on floor, both sides of diamond	
	Door #254A:	
	Install screws at door hardware latch	
	Touch up scratch at bottom outside of door	
	Clean silicone from glass	
	Touch up glass stop. Exposed bare wood at edges.	
	Door #253A:	
	Touch up door frame upper right hand hinge side	
	Replace ceiling tile above door at edge	
	Door #250A:	
	Clean water leaking under door sill	
	Touch up paint at door frame head	
	Install lock and center mullion of door	
	Clean door frame of paint over spray	
	Touch up accent wall bottom between Door #251A and #252A	
	Touch up scratches at bottom of Door #251A and scratches near lite (lower left side)	
	Touch up scratches on Door #252A at bottom and lower right near lite	
	Touch up north wall near Door #174A	
	Clean up ceiling grid of over paint near Door #254A at diamond	
	Remove plastic from far exit light fixture.	
	Touch up diamond furr-down edge at east corner	
	Paint edge of gyp board at light fixtures. Typ.	
	Touch up scratched ceiling tile near first light east of diamond	
	Touch up scratched ceiling tile near east mechanical supply grille	
185	Corridor	
	Floor has not been punched	
	Install base	
	Door #183B:	
	Touch up paint at edge of door frame near hinges	
	Touch up caulking at door frame, latch side	
	Touch up paint on door frame near latch	

	Drinking Fountains:	
	Clean fountains	
	Touch up connection of gyp to ceiling grid above fountains	
	Clean tile	
	Smooth out silicone sealant at tile & fountain	
	Install corners at tile trim	
	At tile base, fix gap between tile and floor on left side	
	Remove floor weld under right fountain	
	Clean paint from Door #187A near hinges	
	Fix wall at ceiling above map rails	
	Install corner guards on column furr-out (near cart storage room)	
	Touch up electrical outlet near column furr-out	
	Touch up ceiling tiles near drinking fountain near ceiling transmitter in front of work room	
193	Corridor (Blue Pod)	
	Floor has not been punched	
	At furr-down, address broken drywall at corner near drinking fountains	
	Touch up furr-down near exit sign	
	Install map rail ends, typ.	
	Door #188A:	
	Touch up paint accent line	
	Remove existing room sign. Fill holes and paint.	
	Touch up door frame to accent paint on latch side of door.	
	Touch up drywall at jamb of door	
	Touch up glass stop at lower right hand corner	
	Door #189A:	
	Touch up accent color on jamb of door (entire length)	
	Touch up ding on jamb (latch side lower)	
	Touch up accent line on Door #190A and repaint lower portion of accent color	
	Align ceiling grid and corner guard near Doors #191A and #190A. Patch busted gyp board at ceiling corner.	
	Patch base at wall on hinge side of door, behind door	
	Door #191A:	
	Clean paint from door and fix ding at top left of glass lite	
	Repaint door frame, top glossy and bottom not	
	Repaint accent paint line edge	
	Remove accent color from edge of door frame	

	Glue top of base to wall under accent band	
	Drinking Fountains:	
	Install tile trim corners	
	Clean tile	
	Clean fountains	
	Fix/address gap below fountain at floor and tile	
	Fix base at corner near Door #192A	
	Door #192A:	
	Clean paint from door near latch	
	Remove old sign from top of door, patch holes and paint	
	Touch up paint on hinge side of door frame (entire length)	
	Touch up paint at accent color on door frame as well as inside corner of wall	
	Door #193A	
	Clean aluminum frame of all dirt and painting overspray	
	Clean threshold of paint, glue and dirt	
	Paint steel door jamb	
	Touch up floor sticking up at south end of door threshold	
	Door #194A	
	Touch up scratches at bottom of door	
	Glue wall base on hinge side of door, coming off	
	Touch up frame at base, hinge side	
	Caulk around FEC	
	Fill hole in wall near outlet under FEC	
	Remove glue from wall at base near corner guard on FEC wall	
	Touch up caulk at corner guard bottom and top on FEC wall	
	Adjust ceiling tile above thermostat on FEC wall	
	2 light fixtures near Door #193A bulbs not working	
	1 light fixture lens to be adjusted. Sticking up	
	Touch up 4 ceiling tiles near mechanical unit on ceiling	
	Touch up center of ceiling tile near speaker near drink fountain	
	Touch up 2 ceiling tiles above drinking fountain	
	Touch up ceiling tile near furr-down exit sign	
	Touch up ceiling tiles in alcove by Room 191	
	Replace ceiling tile water damage above map rails near Classroom 190	
	Touch up accent diamond south facing drinking fountain	
	Touch up accent diamond at corner near 190	

		Touch up accent diamond at corner pointing north	
		Pain edge of gyp board at light fixture in accent diamond	
157	Corridor	Floor has not been punched	
		Clean fire sprinkler cover in front of #163A	
		Touch up scraped tile by light in front of #163A	
		Touch up gyp board furr-down near #163A	
		Touch up ceiling tile at gyp board furr-down near #163A	
		Touch up ceiling tile at top of corner guard near hinge side of Door 158A	
		Address gyp board busted out at top of hinge side of Door 158A	
		Accent diamond paint around lights	
		East corner, clean paint from ceiling grid	
		Clean up sealant from bottom of corner guard at hinge side Door 158A	
		Door 158A:	
		Remove paint from bottom of door	
		Touch up paint at door frame at accent wall	
		Touch up accent wall lower area near base	
		Touch up top of wall at ceiling grid above map rails between #158A and #159A	
		Touch up bottom of wall at base below map rails between #158A and #159A	
		Door #159A:	
		Touch up bottom left of accent wall	
		Clean paint over spray from edge of HM frame. Repaint frame.	
		Touch up dings in door at latch	
		Re-texture drywall at hinge jamb of door. Repaint.	
		Seal FEC cabinet to wall	
		Door #160A:	
		Clean up accent line edge. Touch up	
		Touch up accent wall near base	
		Touch up bottom of door scratches and dings	
		Door #161A:	
		Touch up scratches at bottom of Door #161A	
		Touch up edge of accent band	
		Touch up frame at bottom of jamb hinges and latch side of Door #162A	
		Touch up accent band corner on right side of wall near #162A	
		Touch up wall near ceiling grid above map rails between #162A and 163A	

	Door #163A:	
	Glue base at bottom of door latch side	
	Clean up texture and paint at door frame and wall at hinge & jamb	
	Clean caulking from bottom of corner guard at wing wall hinge side of door.	
195	Corridor	
	Floor has not been punched	
	GEN NOTE: Repaint all classroom door accent walls.	
	Paint edge of gyp board at light fixtures in accent diamond	
	Door #196A:	
	Clean base	
	Paint accent color on latch side of door to corner guard	
	Touch up scratches at bottom of door	
	Touch up paint at latch side base	
	Touch up paint at hinge side jamb, entire length.	
	Remove all wrapping from corner guards	
	Caulk FEC to wall	
	Door #198A:	
	Clean off markings at top of door	
	Remove excess sealant from inside lite	
	Touch up bottom of door jambs, both sides	
	Door #199A:	
	Repaint top portion of door frame, you can see difference in gloss	
	Touch up bottom of door jambs, both sides	
	Touch up wall edge of accent band, bottom of wall.	
	Install ends of map rails	
	Door #200A:	
	Remove existing sign from top of door, patch holes and paint.	
	Touch up bottom jamb, both sides of door latch and hinge	
	Clean and remove paint from outlet cover between #200A and #201A	
	Door #201A:	
	Touch up paint edge of HM frame and bottom of jamb, both sides.	
	Paint accent band on latch side of door	
183A	Storage Room	
	Floor not punched, janitor equipment and cardboard cover in room	
	Clean brick wall	
	Caulk wall behind sink to brick wall	

	Patch ceiling	
199	Classroom	<p>Floor has not been punched</p> <p>Accents tiles at two southeast accent squares don't match well to other accent colors. Replace tiles so all accent colors match.</p> <p>Millwork:</p> <p>Cubbies:</p> <p>Fix Knot holes: 1st, 5th and 12th cubby from door</p> <p>Last cubby cabinet doesn't latch</p> <p>Clean black substance from cabinet faces, typ.</p> <p>Left end panel of bookshelf not finished</p> <p>Teacher's Cabinet:</p> <p>Fill holes on left end panel, inside and out.</p> <p>Fix knots and splits on inside face of doors</p> <p>Floor tile patch near corridor wall does not match</p> <p>VCT tiles gapped under TV stand</p> <p>End panels needed for marker board map rail</p> <p>Map rail doesn't have tack board (cork)</p> <p>Clean outlet under marker board and repaint wall near outlet to cover smudges</p> <p>Clean bugs from lights</p> <p>Clean excess caulking from aluminum window frame</p> <p>Floor tiles at teacher desk wall do not match</p> <p>Touch up bottom glass stop on interior door lite</p> <p>Fill holes in glass stop trim, inside and out.</p>
198	Classroom	<p>Floor has not been punched</p> <p>Millwork:</p> <p>Cubbies:</p> <p>Fix Knot holes: 6th and 10th from door</p> <p>Cubby Shelves:</p> <p>Fix Knot holes: lower 3rd and 9th from door</p> <p>Cubby Cabinets:</p> <p>Fix Knot, lower shelf, 5th from door.</p> <p>Fix Scratches on 2nd cabinet door face</p> <p>Clean Red coating (Paint?) from 4th cabinet near left handle</p> <p>5th cabinet, left side doesn't latch well</p>

		Fill screw holes
		Clean paint from top of bookshelf near Teacher's Cabinet
		Teachers Cabinet:
		Left side, OSB showing over base
		Fix base at lower right side
		Right cabinet face interior knot holes to be fixed
		Fix rubber base at corner near TV mount. Base doesn't turn corner well.
		Floor under market board not installed tightly
		Caulk gap at top of wall adjacent to window, entire wall required
		3 floor tiles busted near floor vent at window
		Clean aluminum window frame and screws of paint and excess caulking
		Clean drywall dust from behind door
		Touch up door near lower hinge and top of door
149	Flex Room	Floor has not been punched
		Cubbies: (Numbered from door)
		3rd cabinet, left door hard to open
		5th cabinet left door does not latch well
		Fill all screw holes on interior of cabinets
		Fix Knots: 5th and 9th lower shelf
		Clean paint from end of cubby panel
		Edge banding of left door of Teacher's Cabinet is rough
		Install tack board on east wall
		Touch up paint at base in front of teacher shelving unit, east wall.
		East wall, touch up paint corner guard inside corner.
		Accent red wall, address exposed J-boxes under marker board, 3 total.
		Clean base under east wall corner guard
		Address exposed J-box above marker board
		Address floor tile and vent under marker board
		Clean light fixture lens
		Replace ceiling tile at north east fire sprinkler head
		Remove and replace floor base installed too high on west wall in front of Teacher's Cabinet
		Install flooring material at threshold of door
		Touch up door at edge near latch
		Clean wall base in corner behind door at bottom hinge

182	Storage Room	Floor has not been punched Glue base at transformer, right side. Paint wall on left side of Panels PP and LL Paint wall above existing tall blue cabinet Paint wall at base above tall blue cabinet Fix base end at each side of door Touch up door frame lower jamb, each side of door.
179	Classroom	Floor has not been punched Touch up base near Door #179B, both sides. Paint cover plate behind thermostat Paint wall under existing cover plate above millwork near Door #179B. Remove existing cover. Paint blank J-box cover to match wall Cover existing clock box on north wall Glue base at 3rd bay on west millwork counter near Door #179B Paint backing plate under intercom buttons Paint fire pull conduit Clean paint from light switch cover Touch up gyp board wall near Door #179A Touch up top right of frame Door #179A Trim base at bottom left of frame Door #179A Address ceiling tile at corner near Storage #180 Address ceiling tile above fire pull Caulk north wall at ceiling connection between Doors #179A and #179B Clean base Paint wall at base behind fridge Fix plam backsplash at 3 locations of existing kitchenette Install cover plate over stove hood Patch floor where exposed at base in corner near Storage #180 and Fir Vent Touch up wall near unisex west door left side (hinge) Touch up wall above base in corner across from unisex door west Clean base under corner guard near Door #180A Repaint south wall near RR #181 Touch up HM frame and wall above Door #181B hinge side and near push plate

181	Restroom	Clean floor Clean all surfaces Patch ceiling to wall connection on east wall Touch up HM frame Door #181A and #181B Patch hole in ceiling near Door #181A Address exposed J-box on west wall Patch hole in Door #181A under pull plate
180	Storage Room	Remove cover plastic from light switch Repaint frame of Door #180A Glue base on east wall across from window top pulling away Touch up sill of window, repaint Repaint west wall near base, north of window Repaint north wall Repaint east wall near Door #150A Clean floor Install cover on fire sprinkler in ceiling
258	Storage Room	Clean entire room.
197	Classroom	Floor has not been punched Floor patches do not match existing floor Floor accent tiles near teacher desk and bookshelf not tight Millwork: (Numbered from Classroom Door) Cubbies: Fix knot at 2nd cabinet door , 3rd cabinet, right door; 4th cabinet door, right; 6th, left door; 7th, left door 4th cabinet, left door, bottom left corner broken. Fix 2nd cubby knots Last shelf near Teacher's Cabinet, fix shelf ding. Right door of Teacher's Cabinet has knots, fix. Bottom right corner of bookshelves to be touched up Address J-box above marker board Clean lights Repaint conduit and J-boxes on accent wall Replace water damaged ceiling tile at fire sprinkler near teacher's desk

156	Storage Room	Floor has not been punched Repaint east and south walls Repaint door frame Fix hole and outlet cover on west wall	
154	MDF	Floor has not been punched Cover exposed wood with gyp board and paint Clean floor Verify intumescent paint properly covers exposed insulation at deck. It doesn't appear to cover completely.	
172	Mechanical	Floor has not been punched Verify intumescent paint properly covers exposed insulation at deck. It doesn't appear to cover completely.	
183	Electrical	Floor has not been punched Verify intumescent paint properly covers exposed insulation at deck. It doesn't appear to cover completely. Clean floors	
260	Storage Room	Floor has not been punched Install missing ceiling tiles Patch holes by outlets on east wall Touch up wall near north outlet east wall	
259	Mechanical	Floor has not been punched Clean floors, replace demoed VCT Verify intumescent paint properly covers exposed insulation at deck. It doesn't appear to cover completely. Install base	
210	P.E. Gym	Not ready for punch.	
206	Storage Room	Not ready for punch.	
	Basement Area	Not ready for punch.	

184A	Storage Room	Not punched.
------	--------------	--------------



August 15, 2013

OBSERVATION OF Mustang 9th Grade Center

OBSERVATION MADE August 14, 2013

GENERAL:

1. Clean all equipment.
2. Start, adjust and test all equipment.
3. Demonstrate equipment to Owner at Owner's convenience.
4. Provide O&M manual per contract documents.
5. Check under edges and corners of all fabricated equipment and remove burrs and sharp edges. Silicone over surfaces not acceptable.
6. ITEM NO. 01 MOBILE TRAY DISPENSER
 - A. Provide bumpers as specified.
7. ITEM NO. 03 MOBILE MILK COOLER
 - A. Provide cord & plug.
8. ITEM NO. 04 SERVING COUNTER
 - A. Replace damaged louvered grille.
 - B. Clean utility compartments.
 - C. Fix display lights to food guard at all connection points.
 - D. Provide & install missing food guard screw cap, north end.
 - E. Repair non-functioning display light, south end.
 - F. Polish out scratches.
 - G. Set serving counter off wall per CDs or trim and seal to wall.
 - H. Provide & install New Age base.
 - I. Provide angle pan supports at cold pan.
9. ITEM NO. 05 SERVING COUNTER
 - A. Replace damaged louvered grille.
 - B. Clean utility compartments.
 - C. Polish out scratches.
 - D. Set serving counter off wall per CDs or trim and seal to wall.
 - E. Provide & install New Age base.
 - F. Provide angle pan supports at cold pan.
 - G. Fix display lights to food guard at all connection points
10. ITEM NO. 06 MOBILE CASHIER'S STAND
 - A. Provide second cashier's stand.
11. ITEM NO. 09 STAINLESS STEEL WALL PANEL
 - A. Tack weld & seal wall panel to splash.
 - B. Extend wall panel over splash at clean dishtable, north end.
 - C. Affix wall panel at dishwasher and clean dishtable.

D. Remove protective film behind dishwasher.

END

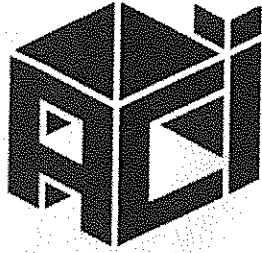

ALLEN CONSULTING INCORPORATED

115 W. Main, Norman, OK
Ph (405) 447-2282

Mechanical Site Observation

Report No.2

Date: August 13, 2013

Project: Mustang Mid-High Renovation
5th & 6th Grade Center
Mustang, Oklahoma

ACI Project No.: 136.12

Date of Visit: August 9, 2013

Persons Present: Heath Q. McKee, PE

Below you will find a copy of some items we observed during a recent site visit. Please have the Contractor address these issues.

General

1. Provide test and balance report.
2. Provide O&M manual.

Roof

1. All gas piping on roof should be painted.
2. Not all roof pipe supports have roof pad. Provide roof pad under all pipe supports.
3. Some roof supports need to have height adjusted. Several were loose, not set correctly or just laying on roof.
4. Provide freeze proof condensate traps on Rooftop units.
5. Coupling on Kitchen unit condensate line split.

Kitchen

1. Equipment has not been relocated under hood. Relocate as indicated on plans.
2. Kitchen Hood controller not operational at time of inspection.
3. Remove 1/4 of grate on floor sink directly under indirect drain.
4. Sprinkler pipe appears to be leaking water at head location. Repair leak.
5. Holes through kitchen hood are required to be sealed in accordance with IMC.

Admin Area

1. Provide cover for condensate box in nurse area restroom.
2. Domestic hot water was found to almost no water pressure in this area. Correct issue.

Basement

1. Refrigerant monitoring system found not operational. System should be interlocked with exhaust fan and damper. It should have horn and strobe at panel interlocked with alarm function.
2. Boiler not operational at time of visit.

3. Seal gap between new louver and existing concrete wall for refrigerant purge system.



Unpainted gas piping and missing roof pad.

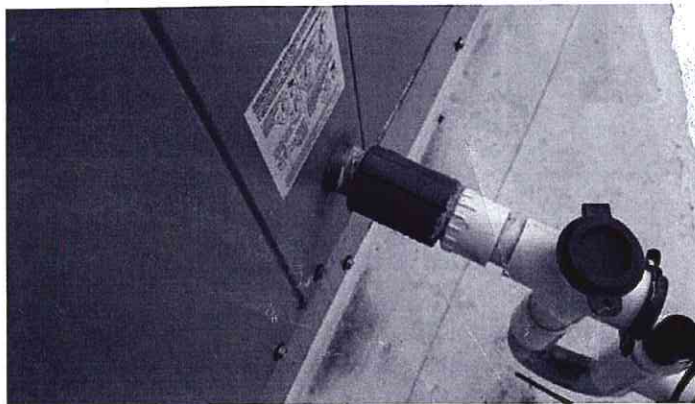

Split coupling on Kitchen unit.

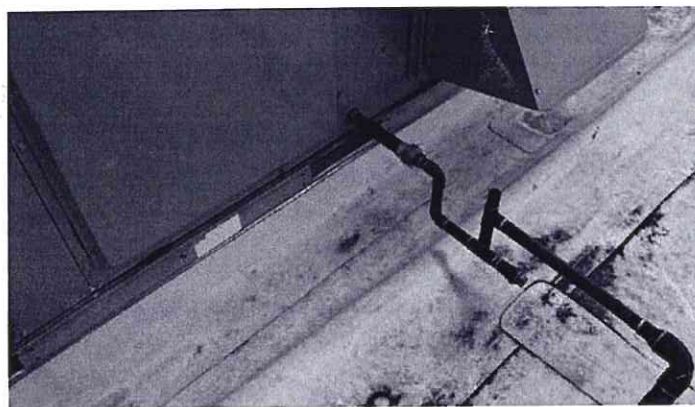

Unit missing freeze-proof trap.

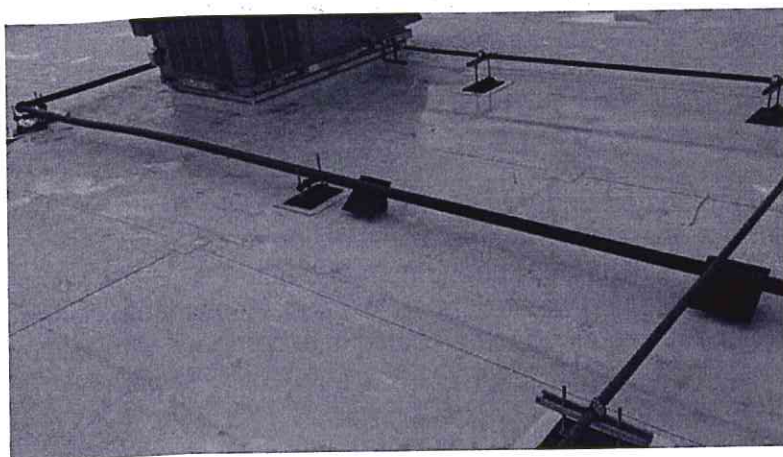

Gas piping stands need to be adjusted.



Kitchen equipment under hood.



New floor sink.

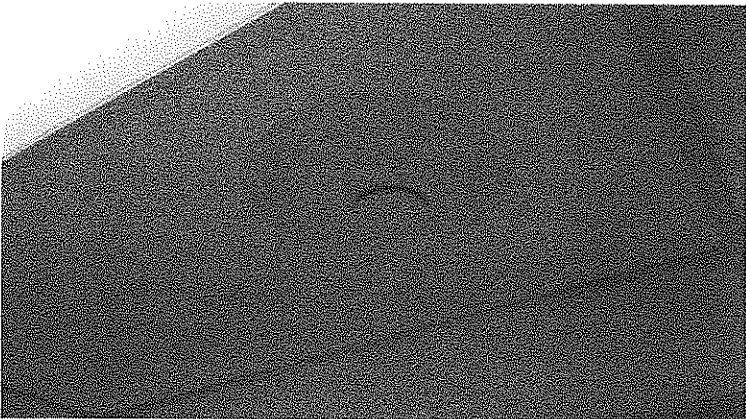

Sprinkler head at water leak.

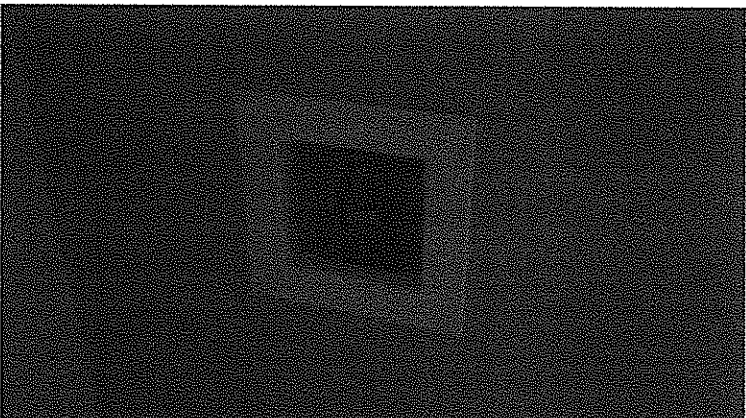

Condensate box at Nurse's restroom.

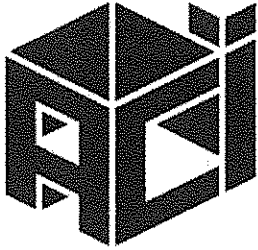

ALLEN CONSULTING INCORPORATED

115 W. Main, Norman, OK
Ph (405) 447-2282

Electrical Site Observations

Date: August 17, 2013

Project: Mustang Mid-High Renovation
5th & 6th Grade Center
Mustang, Oklahoma

ACI Project No.: 136.12

Date of Visit: August 17, 2013

Persons Present: James S. Ruse, PE

Below you will find a copy of some items we observed during a recent site visit. Please have the Contractor address these issues.

1. Program relay panels to control exterior lighting, currently the lighting is on during the day.
2. Label all new receptacles and switch plates with circuit number in accordance with specifications.
3. Install floorbox covers in room 109.
4. Program occupancy sensors per schedule.
5. 4 type LP fixtures are not working in the cafeteria
6. Label low voltage switches for cafeteria. Program controls per plans. Provide engraved signs indicating switch functions in lieu of engraved pushbuttons. Provide training to owner's personnel for operation of this system, schedule training session with owner.
7. Label relays and push buttons in relay panels.
8. Connect lighting to relay panel, connect dimming controls to panel. Demonstrate functions for owner.
9. Light fixture in workroom 153 is not working.
10. Remove conduit from kitchen hood, patch holes in hood.
11. Install typewritten panel schedules in all panels.
12. One type N fixture at the west end of corridor 250 isn't working.
13. Label switches in gym, program panel per details.

14. Install engraved tags on switchboard indicating load served by each breaker.
15. Panel schedule for panel HA is incorrect, provide corrected schedule.
16. Label exterior main disconnect with engraved sign reading "MAIN DISCONNECT".
17. In kitchen, fill abandoned junction boxes with grout.
18. In serving line 126, replace all non-gfi receptacles with new gfi receptacles.

MEMO

To: Sean McDaniel, Superintendent *SM 8/30/13*
From: Jeff Woodard, Director of Bonds/Construction
Date: August 30, 2013
Re: Timberlake Change Order #11

Respectfully request that the Board discuss, consider, and/or act upon approval of the change order from Timberlake Construction for the following on the Sara Rd. Elementary:

- *PC#106- Provide pressure reducing valve per RFI#81 - \$4,375.25
- *PC#115- Emergency lighting per Fire Marshall - \$2,362.55
- *PC#111- Media center aluminum doors - \$973.27
- *PC#112- Add power to music, art and media rooms - \$1,001.98
- *PC#117- Roof drain tie in at gym - \$945.65
- *PC#120- Roof condensate lines - \$806.00
- *PC#121- Dumpster screen allowances – Credit <\$2,500.00>
- *PC#124- Provide Hobart VCM kitchen equipment - \$4,377.39
- *PC#70- Revise window opening for Type O window - \$3,637.00
- *PC#100R- Area inlets to gym courtyard - \$9,882.26

This will be a total **decrease** to the **Construction Contingency** by \$25,861.35

SM
8/30/13



AIA®

Document G701™ – 2001

Change Order

PROJECT (Name and address): Sara Road Elementary - Building 3600 S Sara Road Oklahoma City, OK 73099	CHANGE ORDER NUMBER: 011 DATE: 8-28-13	OWNER: <input checked="" type="checkbox"/> ARCHITECT: <input checked="" type="checkbox"/> CONTRACTOR: <input checked="" type="checkbox"/> FIELD: <input type="checkbox"/> OTHER: <input type="checkbox"/>
TO CONTRACTOR (Name and address): Timberlake Construction Co., Inc. PO Box 18297 Oklahoma City, OK 73154	ARCHITECT'S PROJECT NUMBER: CONTRACT DATE: 4-26-12 CONTRACT FOR: General Construction	

THE CONTRACT IS CHANGED AS FOLLOWS:

(Include, where applicable, any undisputed amount attributable to previously executed Construction Change Directives)
This change order will be a net deduct to the Owner Contingency in the amount of \$ 25,861.35 as follows:

1. PC #106 - Provide pressure reducing valve per RFI #81 - \$4,375.25.
2. PC #115 - Emergency lighting per Fire Marshall - \$2,362.55.
3. PC #111 - Media Center Aluminum Doors - \$973.27.
4. PC #112 - Add power to music, art and media rooms - \$1,001.98.
5. PC #117 - Roof drain tie in at gym - \$945.65.
6. PC #120 - Roof Condensate Lines - \$806.00.
7. PC #121 - Dumpster Screen Allowance \$-<2,500.00>.
8. PC #124 - Provide Hobart VCM kitchen equipment - \$4,377.39.
9. PC #70 - Revise window opening for Type O window - \$3,637.00.
10. PC #100R - Area Inlets to gym courtyard - \$9,882.26.

The original Guaranteed Maximum Price was	\$ 16,801,568.66
The net change by previously authorized Change Orders	\$ 0.00
The Guaranteed Maximum Price prior to this Change Order was	\$ 16,801,568.66
The Guaranteed Maximum Price will be increased by this Change Order in the amount of	\$ 0.00
The new Guaranteed Maximum Price including this Change Order will be	\$ 16,801,568.66

The Contract Time will be increased by Zero (0) days.

The date of Substantial Completion as of the date of this Change Order therefore is

NOTE: This Change Order does not include changes in the Contract Sum, Contract Time or Guaranteed Maximum Price which have been authorized by Construction Change Directive until the cost and time have been agreed upon by both the Owner and Contractor, in which case a Change Order is executed to supersede the Construction Change Directive.

NOT VALID UNTIL SIGNED BY THE ARCHITECT, CONTRACTOR AND OWNER.

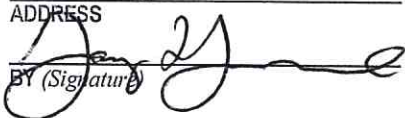
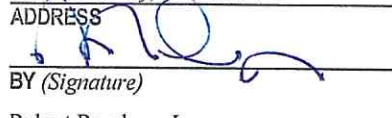
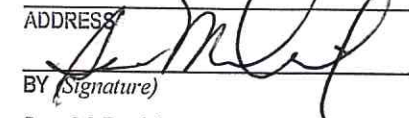
<u>MA+ Architecture</u> ARCHITECT (Firm name)	<u>Timberlake Construction Co., Inc.</u> CONTRACTOR (Firm name)	<u>Mustang Public Schools</u> OWNER (Firm name)
<u>4000 North Classen, Suite 100N,</u> <u>Oklahoma City, OK 73118</u> ADDRESS	<u>PO Box 18297</u> <u>Oklahoma City, OK 73154</u> ADDRESS	<u>906 S Heights Drive, Mustang, OK 73064</u> ADDRESS
<u></u> BY (Signature)	<u></u> BY (Signature)	<u></u> BY (Signature)
<u>08/29/13</u> (Typed name)	<u>Robert Renshaw, Jr.</u> (Typed name)	<u>Sean McDaniel</u> (Typed name)
<u>DATE</u>	<u>8-28-13</u> DATE	<u>DATE</u>

Sara Road Elementary
Contingency Reconciliation Log
8/29/2013

Proposed Change	Owner Change Order	Description	Amount
Total Declared Contingency			\$300,000.00
PC #1	1	Water for site	\$3,044.00
PC #2	1	Kitchen VE revisions	\$3,952.00
PC #3	1	Gravel for box culverts (Pending per city's inspections)	\$1,335.00
PC #4	1	Permit cost increase	\$10,041.00
PC #5	1	ASI 02 additional glass at music	\$671.00
PC #7	1	Gas reheat on units	\$27,263.00
PC #8	1	ASI 05 storm sewer revisions	(\$5,560.00)
PC #9	1	ASI 05 driveway width revisions	(\$6,185.00)
PC #11	2	Earthwork for Alternate Parking	\$6,752.00
PC #12	2	Paving for Alternate Parking	\$5,845.00
PC #14R	2	Valve Freeze Protection	\$8,504.00
PC #18	2	Install gravel base under remaining three culverts (PC #3 only included 1 culvert)	\$4,005.00
PC #10	3	Culvert Revisions	\$15,036.00
PC #13R	3	Added Restroom at kitchen	\$9,304.00
PC 15R	3	Roof color add	\$5,073.00
PC #16	3	Recess Stage Floor	\$927.00
PC #17	3	Expansion joints per ASI 10	\$1,468.00
PC #19	3	Additional silt fence per City	\$2,777.00
PC #20	3	ASI 07 Fire wall revisions	\$35,887.00
PC #21	3	Courtyard Concrete	\$13,071.00
PC #22	3	Flooring Changes	\$837.00
PC #23	4	Culvert headwall revisions	\$15,931.00
PC #24	3	Ceramic Tile and FRP	(\$20,270.00)
PC #25	3	Brick pilasters at gym	(\$9,069.00)
PC #26R	4	Area G parapet	\$4,223.00
PC #27	3	Pipe Chases at teachers lounge	\$261.00
PC #29	4	Mech room wall and door	\$995.00
PC #33	4	Delete two braising pans	(\$9,454.00)
PC #34R2	7	Art Room Revisions	\$9,192.00
PC #35	5	Add/extend concrete footings for brick pilasters per RFP 1R	\$5,767.00
PC #36	5	Add Armstrong 360 15"x16" ceiling grid to Art Room	\$2,327.00
PC #37R	5	Add concrete drop off locations at parking areas per RFP 16	\$13,296.00

40R2	7	Shower Lighting Revisions per RFI 51	\$1,536.00
PC #41	5	Add 64 drawers at removed sink locations	\$1,476.00
PC #42	5	Add water heater to teachers lounge per RFP 14	\$412.00
PC #43	5	Add/change janitor closets per RFP 09.	\$9,071.00
PC #45	5	Change fire wall layout per RFI 46	\$340.00
PC #47R	5	Change flex room walls per RFP 15.	\$958.00
PC #48	5	Delete one layer of sheetrock in kitchen per RFP 12	(\$1,430.00)
PC #49	5	Add roofing transition at precast concrete per RFP 19	\$787.00
PC #51	5	Stucco credit	(\$25,520.00)
PC #53	5	Add new concrete footing to door 103B, per RFI 72.	\$2,059.00
PC #54	5	Add cast stone lintel above added door 116A	\$547.00
PC #56	7	RFI 65 ADA Shower Heads	\$1,588.00
PC #57	6	RFP 22 Stage Elec	\$1,559.00
PC #58R	7	RFP 25 Additional Electric at Rotunda	\$2,864.00
PC #59	6	RFP 26 Serving Menu Display	\$666.00
PC #60	6	RFP 05R Service Drive Area	\$473.00
PC #61	6	RFI 69 Smart Board Rough In	\$2,479.00
PC #62	6	RFI 41 Duct at Music Room	\$622.00
PC #66	7	Furrdow at Rotunda Coiling Doors	\$332.00
PC #67	7	Fiberglass Frame Credit	(\$4,165.00)
PC #68	7	Terrazzo Modifications	\$5,624.00
PC #70	11	Revise Window opening for Type O window	\$3,637.00
PC #71	7	RFP 28 Special Needs Door, Frame and Hardware.	\$1,694.00
PC #75	7	Ceramic Tile Credit	(\$4,902.00)
PC #76	7	RFI 77 Ceiling Expansion Joints	\$633.00
PC #79	8	Flex Room Barrow Lites	\$3,281.00
PC #80	10	Monument Sign at Entry	\$3,500.79
PC #82	7	Corner Guard Revisions	(\$9,072.00)
PC #83	8	Curtains at Special Needs	\$1,931.00
PC #84	8	Revised Roof Rails	\$2,606.00
PC #85	9	Door Canopy at 29C	\$13,791.55
PC #87R	8	Entry Signage	(\$704.75)
PC #88	8	File Room Key Pad Lock	\$515.00
PC #89	8	Public Restroom Tile	\$1,527.00
PC #90	8	Added Power & Data Locations in Administration	\$1,093.00
PC #92	9	Exit light @ Rutunda	\$2,622.32
PC #93	9	Display Rails	\$4,446.83
PC #94	9	Intercom at Art Room	\$645.46
PC #95	9	Ansul Water	\$663.18

PC #96	9	Concrete Bollards	\$2,259.71
PC #97	9	Door Canopy Paint	\$1,453.41
PC #98	9	Courtyard Sidewalks	\$45,433.40
PC #99	9	High Moisture Flooring Adhesive	\$6,524.96
PC #100R	11	Area inlets to gym courtyard	\$9,882.26
PC #101	9	Stage Revisions	\$4,534.37
PC #102	9	Restroom Toilet Partition Pilaster	\$1,154.42
PC #103	10	Add closer, threshold, and stop to Door 21D	\$610.85
PC #105	10	Provide carpet moisture barrier	\$3,203.75
PC #106	11	Provide pressure reducing valve per RFI #81	\$4,375.25
PC #107	10	Modify ductwork & sprinkler system	\$5,855.41
111	11	Media Center Aluminum Doors	\$973.27
112	11	Add power to music, art and media rooms	\$1,001.98
115	11	Emergency Lighting per Fire Marshall	\$2,362.55
117	11	Roof drain tie in at gym	\$945.65
120	11	Roof condensate lines	\$806.00
121	11	Dumpster Screen allowance	(\$2,500.00)
124	11	Provide Hobart VCM kitchen equipment	\$4,377.39

Total Remaining Contingency

\$19,312.99

TIMBERLAKE CONSTRUCTION COMPANY, INC.

TCI JOB # 1224
Sara Road Elementary
PROPOSED CHANGE SUMMARY

DATE: 4/9/2013

PROPOSED CHANGE # 70

CHANGE DESCRIPTION: Price to revise window opening for type O window at the rotunda corners. Rotunda calls for three type O windows but the overall framing dimensions are not large enough for these windows. Price is to modify and reorder the corner glass. The other type O window frames can be utilized to save cost.

#	ITEM CODE	DESCRIPTION	MATERIAL	LABOR	SUB	EQUIPMENT	TOTALS
1		Revise eight type O windows corners at Rotunda	\$3,405.50				\$3,405.50
2							\$0.00
3							\$0.00
4							\$0.00
5							\$0.00
6							\$0.00
7							\$0.00
8							\$0.00
9							\$0.00
10							\$0.00
11							\$0.00
12							\$0.00
13							\$0.00
14							\$0.00
15							\$0.00
16							\$0.00
17							\$0.00
18							\$0.00
19							\$0.00
20							\$0.00
21							\$0.00
22							\$0.00
23							\$0.00
24							\$0.00
		CATEGORY TOTALS	\$3,405.50	\$0.00	\$0.00	\$0.00	\$3,405.50
	0.0000%	SALES TAX	\$0.00	N/A	N/A	\$0.00	\$0.00
	38.4400%	LABOR BURDEN	N/A	\$0.00	N/A	N/A	\$0.00
	0.6800%	SUB BONDS	N/A	N/A	\$29.97	N/A	\$29.97
		SUBTOTALS	\$3,405.50	\$0.00	\$29.97	\$0.00	\$3,435.47
					0.2400%	SUB LIABILITY	\$8.25
					0.8300%	BONDS	\$28.51
					4.0000%	OH&P	\$137.42
					0.3200%	Safety	\$10.99
					0.2200%	Shop Dray	\$7.56
					0.2500%	Cleanup	\$8.59
		TOTAL CHANGE ORDER					\$3,637

SPECIAL NOTES AND COMMENTS ABOUT THIS CHANGE:
Special notes and comments about this change:

Additional time requested due to this change: 0 Days

The work described above represents a change in scope and price and will adjust the time to the original contract as indicated. Timberlake Construction is directed to proceed with this work ASAP and the contract sum will be adjusted by change order within 15 day, or as agreed by the owner/contractor.

AUTHORIZING SIGNATURE

OWNER

AUTHORIZING SIGNATURE

TIMBERLAKE CONSTRUCTION

Change Order Request



"Building A Better View"

C.O.R. # 32102-006

G.C. #

Date: 4/4/2013

Project Name: Sara Road Elementary

Project #: 32102

To: Timberlake Construction
Attn: Brandon Cheney
7613 N. Classen Blvd
P O Box 18297
Oklahoma City, OK 73154

From: TEPCO Contract Glazing, Inc.
Mark Simowitz
11210 Ables Lane
Dallas, TX 75229

Phone: (405) 840-2521 Fax: (405) 840-5469

Phone: (972) 247-1055 Fax: (972) 247-1052

We hereby propose to make the following changes:

Sara Road Elementary - Remake type "O" corner windows

Change Order Price \$3,404.50

This price is good for 5 days. If conditions change, this price is void.

We are requesting a time extension of 5 days in conjunction with this change.

Mark Simowitz 4/4/2013
Author Date Sent

Accepted The above prices and specifications of this Change Order request are satisfactory and are hereby accepted. All work to be performed under same terms and conditions as specified in original contract unless otherwise specified.

Authorized Signature

Date of Acceptance

Change Order Request



"Building A Better View"

C.O.R. # 32102-006

G.C. #

Date: 4/4/2013

Project Name: Sara Road Elementary

Project #: 32102

Materials

Materials	Quantity	Cost	Total Tax	Total Materials
Windows	1.00	\$3,095.00	\$0.00	\$3,095.00
			Sub Total	\$3,095.00
			Grand Total	\$3,095.00
Total Cost				\$3,095.00
Overhead				\$309.50
Total				\$3,404.50

TIMBERLAKE CONSTRUCTION Change Order Cost Analysis Recap

Project: Sara Road Date: 03/27/2013
 Job #: 32102 GC CO#
 Subcontractor Co. Name: TEPCO Contract Glazing
 Prepared By: William MacDermott

Total Change Order Price equals Grand Total (M) below
 Description of Work: Add to remake 8 type "O" window panels

Work Not included: _____

COST SUMMARY:

Total Labor Cost	(A)	<input type="text" value="\$0.00"/>	Total of breakdown below
Labor Breakdown:			
		Rate	
			example
			\$
			\$
			\$
Material Subtotal	(B)	<input type="text" value="\$3,095.00"/>	Breakdown MUST BE ATTACHED
Sales Tax @ <u>0</u> %	(C.)	<input type="text" value="\$0.00"/>	
Materials Total (B+C)=	(D)	<input type="text" value="\$3,095.00"/>	
Subtotal Labor + Materials (A+D)=	(E)	<input type="text" value="\$3,095.00"/>	
10%Overhead/Profit	(F)	<input type="text" value="\$309.50"/>	(E) times 10%
Subtotal: (E+F)=	(G)	<input type="text" value="\$3,404.50"/>	Subcontractor Total

Lower Tier Sub Name: _____

Total Lower-Tier Sub Cost	(H)	<input type="text" value="\$"/>	-Attach subs breakdown
5% O & P	(I)	<input type="text" value="\$"/>	(H) times 5%
Subtotal (H + I)=	(J)	<input type="text" value="\$"/>	Lower Tier Sub Total
Subtotal (G+J)=	(K)	<input type="text" value="\$"/>	Combined Total of Sub & Lower Tier Sub
Bond Rate:%	(L)	<input type="text" value="\$"/>	(K) times Bond Rate %
GRAND TOTAL (K+L)=	(M)	<input type="text" value="3404.5"/>	Total Proposed Change Order Amount
Extra Estimated OT Cost for an Add'l Shift 6 (10's)		<input type="text" value="\$"/>	*DO NOT add this Cost to the Grand Total

NOTICE: CHANGE ORDER REQUIREMENTS

All subcontractors & suppliers must provide the following for change orders to be processed:
 A detailed breakdown which includes the labor rates, hours per rate, materials cost breakdown & lower tier subs breakdown of costs along with this Change Order Cost Analysis recap sheet.
 Change Orders submitted without this documentation will be returned unprocessed.
 Maximum allowed subcontractor markup is 15% total (not 10% + 5%) Lower Tier Sub markup is 5%
 *See add'l procedures for OT change order requests.

TIMBERLAKE CONSTRUCTION COMPANY, INC.

TCI JOB # 1224
Sara Road Elementary
PROPOSED CHANGE SUMMARY

DATE: 7/16/2013

PROPOSED CHANGE # 100R

CHANGE DESCRIPTION: Price to new area inlets, associated piping per the attached sketch's.

ADDITIONAL TIME REQUESTED DUE TO THIS CHANGE:

#	ITEM CODE	DESCRIPTION	MATERIAL	LABOR	SUB	EQUIPMENT	TOTALS
1		New site drainage at courtyards	\$2,156.55	\$1,347.75	\$3,668.45	\$787.50	\$7,860.25
2							\$0.00
3		New area inlets from Nance	\$1,393.53				\$1,393.53
4							\$0.00
5							\$0.00
6							\$0.00
7							\$0.00
8							\$0.00
9							\$0.00
10							\$0.00
11							\$0.00
12							\$0.00
13							\$0.00
14							\$0.00
15							\$0.00
16							\$0.00
17							\$0.00
18							\$0.00
19							\$0.00
20							\$0.00
21							\$0.00
22							\$0.00
23							\$0.00
24							\$0.00
CATEGORY TOTALS			\$3,550.08	\$1,347.75	\$3,668.45	\$787.50	\$9,253.78
0.0000%	SALES TAX		\$0.00	N/A	N/A	\$0.00	\$0.00
38.4400%	LABOR BURDEN		N/A	\$0.00	N/A	N/A	\$0.00
0.8800%	SUB BONDS		N/A	N/A	\$81.43	N/A	\$81.43
SUBTOTALS			\$3,550.08	\$1,347.75	\$3,649.88	\$787.50	\$9,335.21
					0.2400% SUB LIABILITY		\$22.40
					0.8300% BONDS		\$77.48
					4.0000% OH&P		\$373.41
					0.3200% Safety		\$29.87
					0.2200% Shop Dray		\$20.54
					0.2500% Cleanup		\$23.34
TOTAL CHANGE ORDER							\$9,882.26

SPECIAL NOTES AND COMMENTS ABOUT THIS CHANGE:
Special notes and comments about this change:

Additional time requested due to this change: 0 Days

The work described above represents a change in scope and price and will adjust the time to the original contract as indicated. Timberlake Construction is directed to proceed with this work ASAP and the contract sum will be adjusted by change order within 15 day, or as agreed by the owner/contractor.

AUTHORIZING SIGNATURE

OWNER

AUTHORIZING SIGNATURE

TIMBERLAKE CONSTRUCTION

H & H Plumbing & Utilities, Inc.

266 Industrial Blvd., Goldsby, OK 73093-9116
(405) 288-2346 (405) 288-2349 FAX

Lic. No.
OK 02653

Contractor: <u>Timberlake Const. Co., Inc.</u>	Ph.#: <u>840-2521</u>	Project: <u>Sara Road Elementary</u>
Address: <u>P.O. Box 18297</u>	Fax #: <u>840-5469</u>	Address: <u>3600 S Sara Rd., OKC</u>
<u>Oklahoma City, OK 73154</u>	Email: <u>brandonc@timberlakeconstruction.com</u>	

Revised price change request to install four area drains and pour three area drain concrete boxes.

<u>A</u>	<u>Material</u>	Unit	Qty	Price	Total
	12" HDPE storm pipe	LF	37	7.00	259.00
	6" HDPE storm pipe	LF	95	2.74	260.30
	12" x 6" HDPE saddle tees	EA	1	73.25	73.25
	15" x 6" HDPE saddle tees	EA	2	88.10	176.20
	15" x 12" HDPE tees	EA	1	149.00	149.00
	6" HDPE 90° Bend	EA	1	15.00	15.00
	6" Cantex	EA	2	8.40	16.80
	12" Grated inlet with pedestrian grates & 6" outlet	EA	1	350.00	350.00
	15" HDPE couplings	EA	3	14.00	42.00
	Concrete	CY	7	95.00	665.00
	Misc rebar	LS	1	150.00	150.00
					2,156.55
				Tax	0.000%
					-
					2,156.55
<u>B</u>	<u>Labor</u>				
	Operator	Hrs	22.5	33.60	756.00
	Helper	Hrs	22.5	26.30	591.75
					1,347.75
<u>C</u>	<u>Equipment</u>				
	Truck	Hrs	22.5	15.00	337.50
	Trackhoe (Mini)	Hrs	22.5	20.00	450.00
					787.50
<u>D</u>	<u>Subcontract</u>				
	Robinett's Concrete Structures, LLC (labor & forms for inlets)	EA	3	600.00	1,800.00
					1,800.00
				Subtotal	6,091.80
<u>E</u>	<u>Overhead</u>			15%	913.77
					7,005.57
<u>F</u>	<u>Profit</u>			10%	700.56
					\$ 7,706.13
<u>G</u>	<u>Bonding</u>			2%	154.12
				Total	\$ 7,860.25

Total Add to Contract \$ 7,860.00

Submitted by: Carl Hendrix

Title: Vice President

Date: 7/16/2013

Accepted by: _____

Title: _____

Date: _____ 256



Credit Card Detail Report

Thursday, June 27, 2013 1:03:55 PM

TransID	Date	Trans Type	Status	Ticket	Issuer	Card	Member	AVS Response	Auth	Trans Ref	Amount
1513	06/27/13	Sale	Active	27665	AMEX	3782.....1855 (M)	daniel baton	Address + 5-digit zip match	299257	65023177	\$1,290.00
Totals for Merchant #: 090108009555							M= Manually Entered				Totals: \$1,290.00
Sales:											* Net added to Totals
Credits:											
Voids:											
Pre-Auths:											
Post-Auths:											
Reversals:											
Sales w/ Gratuity:											
Books:											
Ships:											

This report was generated using the following filters:

Start Date/Time: Thursday, June 27, 2013 12:00:00 AM
 End Date/Time: Thursday, June 27, 2013 11:59:59 PM
 Member:
 Card:
 TID: All
 Card Type: All
 Result: Approved
 User:
 Batch Number:
 Ticket:
 Amount:

#1224
 Daniel Batton
 Gents + extensions
 DANCE PRECAST

NANCE PRECAST CONCRETE PRODUCTS
 PO Box 116
 Piedmont, OK 73078
 (405) 373-1800



www.nanceprecast.com

Page: 1
 Invoice

Invoice Number: 0027685-IN
 Invoice Date: 6/27/2013
 Order Number: 0011158
 Order Date: 6/14/2013
 Salesperson: Brandon Gauthier
 Customer Number: T1M031

Sold To:
 Timberlake Construction Co. Inc
 PO Box 18297
 7513 N. Classen Blvd.
 OKLAHOMA CITY, OK 73154

Ship To:
 Sarah rd Elem.
 CUSTOMER PICK UP
 PIEDMONT, OK

Confirm To: Darrell 535-8958

Customer P.O.	Ship VIA	F.O.B.	Terms Net 30 Days w/ Approved Credit		
Item Number		Unit	Shipped	Price	Extension
MISC SALE	V5724 UND FRAME	EACH	6.000	100.00	600.00
MISC SALE	V5724-80 UND PED GRATE	EACH	3.000	130.00	390.00
MISC SALE	3" Riser Ring	EACH	2.000	150.00	300.00

#1224
 Darrell BKS
 Gates & Extensions
 Page 2 of 2

Net Invoice: 1,290.00
 Less Discount: 0.00
 Freight: 0.00
 Sales Tax: 0.00
 Invoice Total: 1,290.00

D P Supply Co.

"Castings Specialists"

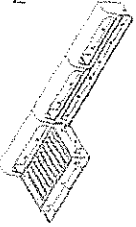
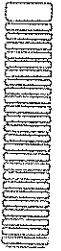

NO CREDIT ALLOWED ON GOODS RETURNED WITHOUT OUR PERMISSION

D P Supply Co. • 19711 E. 6th Street Tulsa, OK 74108 • Office (918) 266-0209 • Fax (918) 266-0235

27087

DELIVERY

A FINANCE CHARGE OF 1% PER MONTH, EQUAL TO 18% PER YEAR WILL BE ADDED TO ALL PAST DUE ACCOUNTS

DATE OF CUST. ORDER		SALESMAN	JOB	P.O. No.		BACK ORDER FROM	BACK ORDER TO	SHIP VIA
S O L D T O						ORDERED BY		DATE SHIPPED
TAX EXEMPT								FILLED BY
								CHECKED BY

QUANTITY ORDERED	QUANTITY SHIPPED	QUANTITY B.O.	PART NO.	DESCRIPTION	UNIT PRICE	NET PRICE	UNIT COST	COST EXTENSION
				STEEL RING WENT TO SAIRA Rd ELM School Job 1224				
						103.53		

HAPP PAID FOR
THIS BILL
STEEL RING WENT
TO SAIRA Rd ELM
School Job 1224

918-266-0209
UTILITY SUPPLY CO
19711 E 6TH ST
TULSA OK 74108
TERMINAL I.O.#
0110
66065
ITEM #: 091
UTSA
*****1219
SALE
DATE: JUL 10, 2013 TIME: 07:31
AUTH NO: 055050
\$103.53
TOTAL
HAP A SCHIRASE
HAP A CUSTOMER COPY

INCL. 2 - Hvy HEX NUTS	
7/8 X 12	7/8 X 12
BLACK	ZINC
1/2 WASHER	

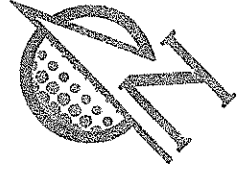
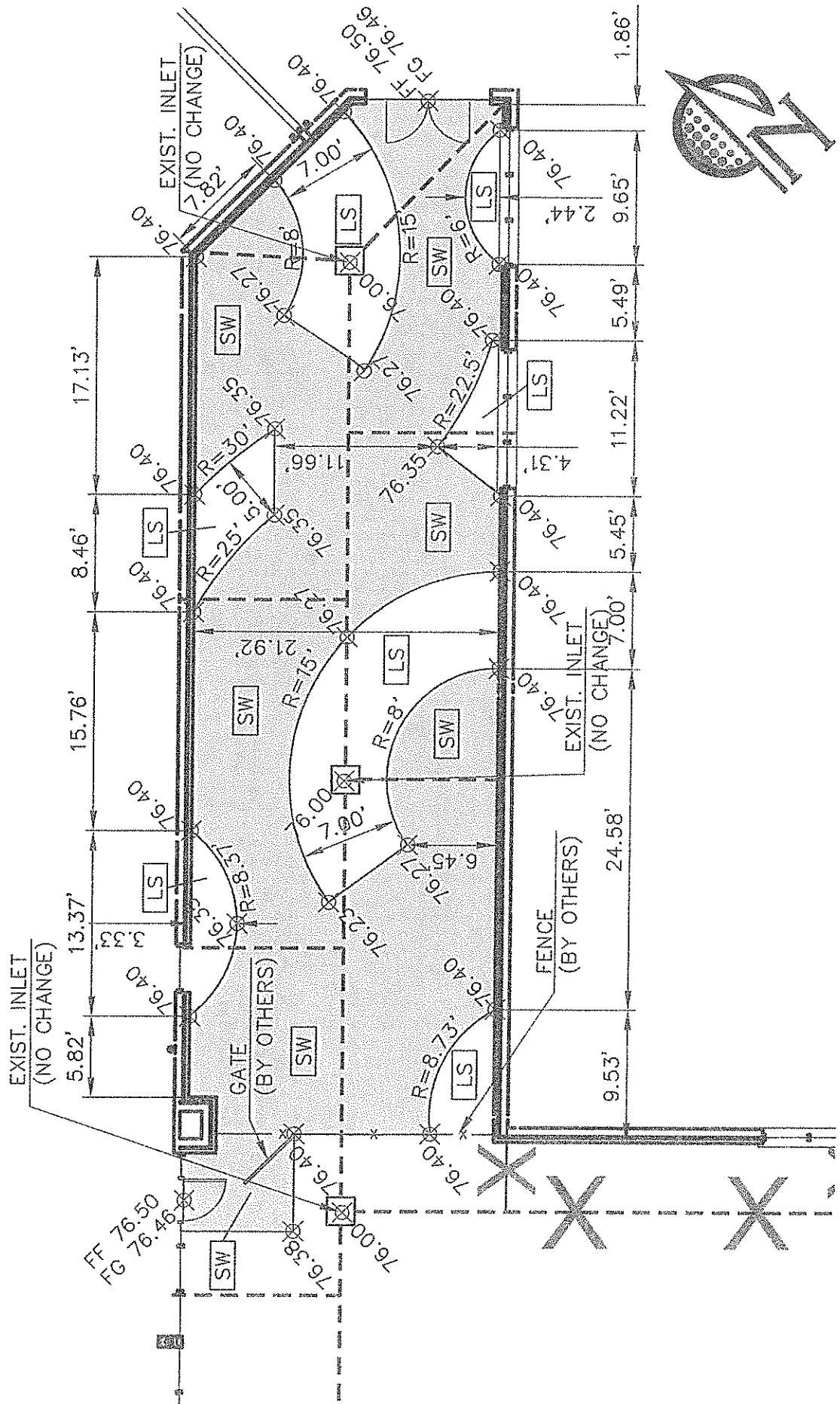

MEDIA CENTER COURT YARD REVISION

SCALE: 1"=10'

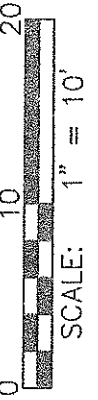

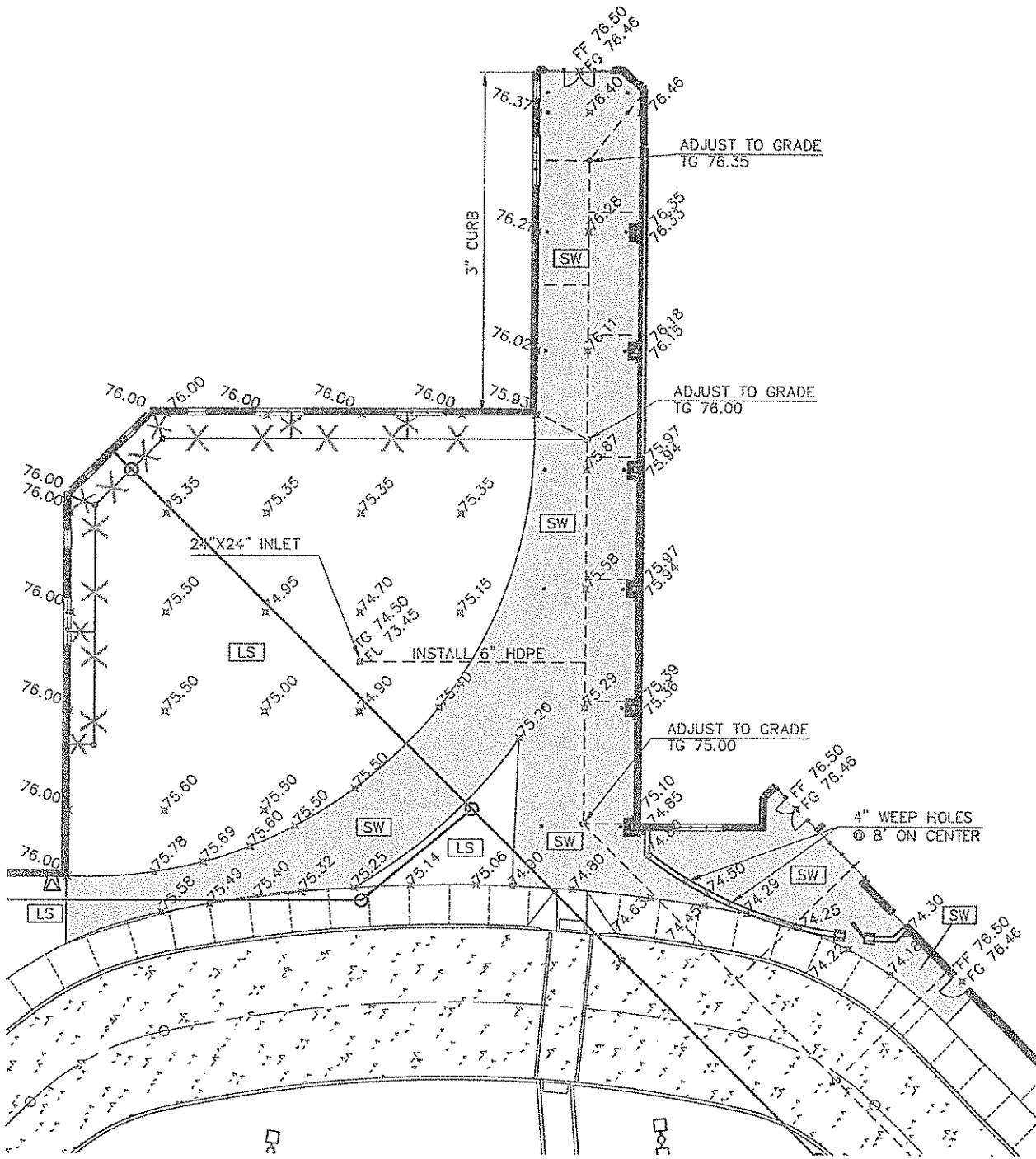

SOUTH EAST COURT YARD REVISION

SCALE: 1"=20'

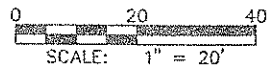

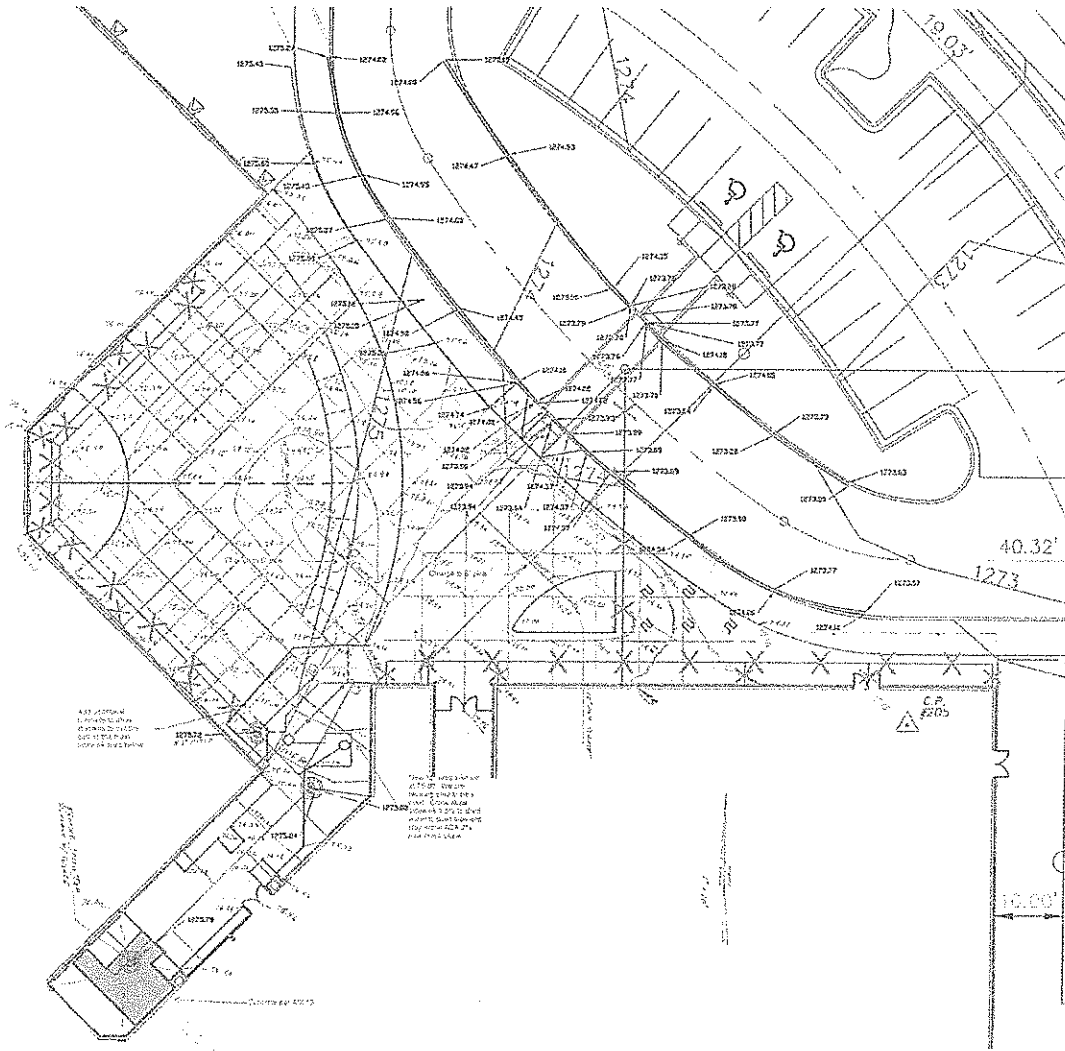

Brandon Cheney

From: Melissa Szymanski <nwmech_melissa@att.net>
Sent: Tuesday, July 16, 2013 1:19 PM
To: Brandon Cheney
Subject: Re: RFI 1F-Pressure

Brandon,

The labor for this job will be \$611.00 and the material is \$3486.00. I wanted to get the numbers to you ASAP; I will attach and send the breakdown shortly. Thanks!

Melissa Szymanski

Northwest Plumbing & Mechanical Inc.

580-233-0225

Please note the new email address and delete the old nwplumbingmex@shawbizal.net or nwplumbing_melissa@shawbizal.net

TIMBERLAKE CONSTRUCTION COMPANY, INC.

TCI JOB # 1224
Sara Road Elementary
PROPOSED CHANGE SUMMARY

DATE: 8/20/2013

PROPOSED CHANGE # 111

CHANGE DESCRIPTION: Price to change Media Center doors from wood to aluminum to match adjacent doors and storefront material. TCI was able to get the aluminum door contractor to split this cost to help mitigate the cost due to the error on the door schedule.

ADDITIONAL TIME REQUESTED DUE TO THIS CHANGE:

#	ITEM CODE	DESCRIPTION	MATERIAL	LABOR	SUB	EQUIPMENT	TOTALS
1		Add aluminum doors to Media Center (price is split in half)	\$488.50	\$304.00	\$118.88		\$911.38
2							\$0.00
3							\$0.00
4							\$0.00
5							\$0.00
6							\$0.00
7							\$0.00
8							\$0.00
9							\$0.00
10							\$0.00
11							\$0.00
12							\$0.00
13							\$0.00
14							\$0.00
15							\$0.00
16							\$0.00
17							\$0.00
18							\$0.00
19							\$0.00
20							\$0.00
21							\$0.00
22							\$0.00
23							\$0.00
24							\$0.00
CATEGORY TOTALS			\$488.50	\$304.00	\$118.88	\$0.00	\$911.38
0.0000%	SALES TAX		\$0.00	N/A	N/A	\$0.00	\$0.00
38.4400%	LABOR BURDEN		N/A	\$0.00	N/A	N/A	\$0.00
0.8800%	SUB BONDS		N/A	N/A	\$8.02	N/A	\$8.02
SUBTOTALS			\$488.50	\$304.00	\$126.90	\$0.00	\$919.40
					0.2400% SUB LIABILITY		\$2.21
					0.8300% BONDS		\$7.63
					4.0000% OH&P		\$36.78
					0.3200% Safety		\$2.94
					0.2200% Shop Dray		\$2.02
					0.2500% Cleanup		\$2.30
TOTAL CHANGE ORDER							\$973.27

SPECIAL NOTES AND COMMENTS ABOUT THIS CHANGE:

Special notes and comments about this change:

Additional time requested due to this change: 0 Days

The work described above represents a change in scope and price and will adjust the time to the original contract as indicated. Timberlake Construction is directed to proceed with this work ASAP and the contract sum will be adjusted by change order within 15 day, or as agreed by the owner/contractor.

AUTHORIZING SIGNATURE

OWNER

AUTHORIZING SIGNATURE

TIMBERLAKE CONSTRUCTION

To : Tepco Contract Glz Inc 11210 Ables Ln Dallas, TX 75229 Attn :	Job Name : Sara Rd - door Quote # : TER130702389 From : Elevation Take Off
---	--

This quote covers only the materials listed below. Price quoted is firm for 30 days from below date and is subject to our terms and conditions of sale as defined herein. **TERMS OF THIS SALE ARE: Net 30.**
 Material must ship before the end of the 4th Qtr. of 2013.

DOORS INCLUDED IN THIS BID:

- 1: 72" X 84" RUGGED WIDE STYLE PAIR OF DOORS CLASS I CLEAR
- 10" BOTTOM RAIL
- 5" HORIZONTAL MUNTIN
- STOPS FOR 1/4" GLAZING
- NO PREPS OR HARDWARE INCLUDED

EXCEPTIONS AND DEVIATIONS:

No Shop Drawings, or calculations. No anchors, fasteners, trim or glass. Standard two year warranty is included.

Class No.	Finish	Total Net Price (All Prices Exclude Sales Tax)
✓ I	Clear	Base Bid \$977.00
	Dark Bronze	
	Black	
	Exterior Paint	
	Interior Paint	
	Mill	
	Other	
		Approximate shipping date: To be advised after receipt of purchase order and/or approved shop drawings.
		F.O.B. shipping point, freight.
		✓ Allowed Collect

General Notes:

1. This quotation will be referred to on and made an integral part of all purchase orders. No contract of sale shall occur unless and until a purchase order is received and accepted in writing by Oldcastle BuildingEnvelope and buyer's credit is approved.
2. Quantities are calculated to complete the units defined herein. Additional requirements will be considered extra to contract.
3. Oldcastle BuildingEnvelope does not assume responsibility for quantities of stock length take-off due to various methods of fabrication. We suggest you check your take-off against the material listed herein.
4. When using Oldcastle BuildingEnvelope products, for your own protection, be sure job conditions are satisfactory. Laws and Building and Safety Codes vary widely, be sure the products you plan to use are clearly specified and approved and suitable for the application. Oldcastle BuildingEnvelope does not assume responsibility for mis-application of products quoted herein.

NOTE

This proposal is qualified by
Design and/or Quantities listed
- READ CAREFULLY -

By: Karen Hilgenfeld

Karen Hilgenfeld

Title: Customer Service Representative

Date: 07-23-2013

TEPCO Contract Glazing
 4703 Enterprise Drive
 Oklahoma City 73129

Ph. (405) 246-9334
 Fax (405) 227-9105

TEPCO Contract Glazing CE# 32102-005
 GC/CM# _____
 Change Order # _____

Date of Submission: 8/16/2013

COST ESTIMATE FORM

Estimating change order amounts between Tepco Contract Glazing and Customer

Project: Sara Road Elementary

Issued to: Timberlake Construction

Scope of Work - or see attached description

LUMP SUM PROPOSAL FOR THE FOLLOWING:
 Provide and install one pair of aluminum storefront entrance doors 6'0 X 7'0 with prep for hardware.

COSTS			
Labor Type	Price/Hr	# Hrs	Cost
Glaizer	\$38.00	16	\$608.00
	\$0.00	0	\$0.00
	\$0.00	0	\$0.00
	\$0.00	0	\$0.00
Total Labor Cost			\$608.00
Material Costs			\$977.00
Subcontractors' Cost			\$0.00
Equipment			\$0.00
Set Up Fee			\$0.00
Energy Surcharge			\$0.00
Miscellaneous			\$0.00
Total Materials Costs			\$977.00
Subtotal of Costs			\$1,585.00
% Overhead	15.0%		\$237.75
Total after Overhead			\$1,822.75
% Profit	0.0%		\$0.00
Total after Profit			\$1,822.75
% Bonding	0.0%	% Sales tax	0.0000
	\$0.00		\$0.00
TOTAL	LUMP SUM		\$1,822.75

Has a change order been issued? **NO**

Date: _____
 Amount: _____
 CO #: _____
 Changes to schedule: _____ (days)

- Attachments:
- A. _____
 - B. _____
 - C. _____
 - D. _____
 - E. _____

If you are authorizing Tepco to proceed with the above-referenced work, please sign and fax this back to Tepco.

Authorized by: _____ Printed Name _____
 Company: _____
 Date: _____

TEPCO Contract Glazing
4703 Enterprise Drive
Oklahoma City 73129

Ph. (405) 246-9334
Fax (405) 227-9105

Breakdown of labor	1 man	8 hours	prep doors for panic and handle hardware
	2 men	4 hours	install doors and adjust

Blank doors	\$977.00
-------------	----------



BRADLEY
ELECTRIC Inc.

Invoice

P O BOX 238
PIEDMONT, OK 73078
405-943-2442 Fax # 405-943-3442

Date 8/15/2013
Invoice # 130811-1

Bill To

TIMBERLAKE CONSTRUCTION
P. O. BOX 18297
OKLAHOMA CITY, OK 73154

Job Location/Description

SARA ROAD EXTRA
INSTALL OUTLETS IN MUSIC
ROOM,
ART ROOM, AND MEDIA ROOM

Terms Net 30
Due Date 9/14/2013

Description	Qty	Rate	Serviced	Amount
12-2/C MC CABLE W/GRN GRD	95	1.107	8/15/2013	105.17
3/8 MC CONNECTOR	12	1.4246	8/15/2013	17.10
3/8 MC STRAP	5	0.24	8/15/2013	1.20
BOX SUPPORTS	6	1.0332	8/15/2013	6.20
20A COMM DPX REC. B&S WIRED	3	14.35	8/15/2013	43.05
1G 302 SS DPLX RCPT PLATE	3	3.22	8/15/2013	9.66
SCOTCHLOCKS-RED	18	0.3268	8/15/2013	5.88
ELECTRICIAN REGULAR RATE	12.5	60.00	8/15/2013	750.00

Total \$938.26



BRADLEY
ELECTRIC Inc.

Invoice

P O BOX 238
PIEDMONT, OK 73078
405-943-2442 Fax # 405-943-3442

Date 8/19/2013
Invoice # 130801-1

Bill To

TIMBERLAKE CONSTRUCTION
P. O. BOX 18297
OKLAHOMA CITY, OK 73154

Job Location/Description

SARA ROAD EXTRA
INSTALL EM. CIRCUITS IN
PANEL ROOMS
'C', AND 'B'. INSTALL EM
LIGHTS IN PANEL
ROOMS 'A', AND 'D'.
AS PER FIRE MARSHAL

Terms Net 30
Due Date 9/18/2013

Description	Qty	Rate	Serviced	Amount
ELECTRICIAN REGULAR RATE	2	60.00	8/5/2013	120.00
ELECTRICIAN REGULAR RATE	2	60.00	8/5/2013	120.00
ELECTRICIAN REGULAR RATE	2.25	60.00	8/6/2013	135.00
ELECTRICIAN REGULAR RATE	5.75	60.00	8/6/2013	345.00
DUAL HEAD EMERG LIGHT	2	67.71	8/5/2013	135.42
12-3/C MC CABLE W/GRN GRD	50	1.87842	8/15/2013	93.92
3/8 MC STRAP	16	0.24	8/15/2013	3.84
3/8 MC CONNECTOR	8	1.4246	8/15/2013	11.40
CUT-IN BOX 3-1/2 DEEP	2	4.5186	8/15/2013	9.04
BOX SUPPORTS	4	1.0332	8/15/2013	4.13
SCOTCHLOCKS-RED	15	0.3268	8/15/2013	4.90
TEK SCREWS	35	0.10	8/15/2013	3.50

Total \$986.15



**BRADLEY
ELECTRIC Inc.**

Invoice

P O BOX 238
PIEDMONT, OK 73078
405-943-2442 Fax # 405-943-3442

Date 8/19/2013

Invoice # 130814-1

Bill To

TIMBERLAKE CONSTRUCTION
P. O. BOX 18297
OKLAHOMA CITY, OK 73154

Job Location/Description

INSTALL EM. LTS. IN MUSIC
ROOM NOT
SHOWN ON PRINTS AS PER
FIRE MARSHAL

Terms Net 30

Due Date 9/18/2013

Description	Qty	Rate	Serviced	Amount
ELECTRICIAN REGULAR RATE	16	60.00	8/6/2013	960.00
12-3/C MC CABLE W/GRN GRD	50	1.87842	8/6/2013	93.92
3/8 MC STRAP	16	0.24	8/6/2013	3.84
3/8 MC CONNECTOR	8	1.4246	8/6/2013	11.40
CUT-IN BOX 3-1/2 DEEP	2	4.5186	8/6/2013	9.04
BOX SUPPORTS	4	1.0332	8/6/2013	4.13
SCOTCHLOCKS-RED	15	0.3268	8/6/2013	4.90
TEK SCREWS	35	0.10	8/6/2013	3.50
DUAL HEAD EM. LT.	2	67.71	8/6/2013	135.42

Total \$1,226.15

TIMBERLAKE CONSTRUCTION COMPANY, INC.

TCI JOB # 1224
Sara Road Elementary
PROPOSED CHANGE SUMMARY

DATE: 8/20/2013

PROPOSED CHANGE # 117

CHANGE DESCRIPTION: Price to tie roof drain at gym door into the underground storm water system. Current design had roof drain exiting the wall via cow tongue at door area.

ADDITIONAL TIME REQUESTED DUE TO THIS CHANGE:

#	ITEM CODE	DESCRIPTION	MATERIAL	LABOR	SUB	EQUIPMENT	TOTALS
1		Tie roof drain into underground storm water	\$262.09	\$301.70	\$199.22	\$122.50	\$885.51
2							\$0.00
3							\$0.00
4							\$0.00
5							\$0.00
6							\$0.00
7							\$0.00
8							\$0.00
9							\$0.00
10							\$0.00
11							\$0.00
12							\$0.00
13							\$0.00
14							\$0.00
15							\$0.00
16							\$0.00
17							\$0.00
18							\$0.00
19							\$0.00
20							\$0.00
21							\$0.00
22							\$0.00
23							\$0.00
24							\$0.00
		CATEGORY TOTALS	\$262.09	\$301.70	\$199.22	\$122.50	\$885.51
	0.0000%	SALES TAX	\$0.00	N/A	N/A	\$0.00	\$0.00
	38.4400%	LABOR BURDEN	N/A	\$0.00	N/A	N/A	\$0.00
	0.8800%	SUB BONDS	N/A	N/A	\$7.79	N/A	\$7.79
		SUBTOTALS	\$262.09	\$301.70	\$207.01	\$122.50	\$893.30
					0.2400%	SUB LIABILITY	\$2.14
					0.8300%	BONDS	\$7.41
					4.0000%	OH&P	\$35.73
					0.3200%	Safety	\$2.86
					0.2200%	Shop Dray	\$1.97
					0.2500%	Cleanup	\$2.23
		TOTAL CHANGE ORDER					\$945.65

SPECIAL NOTES AND COMMENTS ABOUT THIS CHANGE:

Special notes and comments about this change:

Additional time requested due to this change: 0 Days

The work described above represents a change in scope and price and will adjust the time to the original contract as indicated. Timberlake Construction is directed to proceed with this work ASAP and the contract sum will be adjusted by change order within 15 day, or as agreed by the owner/contractor.

AUTHORIZING SIGNATURE
OWNER

AUTHORIZING SIGNATURE
TIMBERLAKE CONSTRUCTION

Lic. No.
OK 02653

H & H Plumbing & Utilities, Inc.

266 Industrial Blvd., Goldsby, OK 73093-9116
(405) 288-2346 (405) 288-2349 FAX

Contractor: <u>Timberlake Const. Co., Inc.</u>	Ph.#: <u>840-2521</u>	Project: <u>Sara Road Elementary</u>
Address: <u>P.O. Box 18297</u>	Fax #: <u>840-5469</u>	Address: <u>3600 S Sara Rd., OKC</u>
<u>Oklahoma City, OK 73154</u>	Email: <u>brandonc@timberlakeconstruction.com</u>	

Price change request to tie one roof drain downspout into an existing 15" underground storm pipe approximately 20' away that was dumping out near an outside door.

<u>A</u>	<u>Material</u>	<u>Unit</u>	<u>Qty</u>	<u>Price</u>	<u>Total</u>
	6" ADS storm pipe	LF	20	2.74	54.80
	15" x 6" ADS saddle tee	EA	1	88.10	88.10
	6" Schedule 40 pipe	LF	6	3.00	18.00
	6" Schedule 40 90° bend	EA	2	20.35	40.70
	6" CI x Plastic cantex	EA	1	27.19	27.19
	Top soil	Bag	1	33.30	33.30
					262.09
				Tax	0.000%
					-
					262.09
<u>B</u>	<u>Labor</u>				
	Operator	Hrs	3.5	33.60	117.60
	Helper	Hrs	7	26.30	184.10
					301.70
<u>C</u>	<u>Equipment</u>				
	Truck	Hrs	3.5	15.00	52.50
	Trackhoe (Mini)	Hrs	3.5	20.00	70.00
					122.50
				Subtotal	686.29
<u>D</u>	<u>Overhead</u>			15%	102.94
					789.23
<u>E</u>	<u>Profit</u>			10%	78.92
					\$ 868.15
<u>F</u>	<u>Bonding</u>			2%	17.36
				Total	\$ 885.51

Total Add to Contract \$ 885.00

Submitted by: *Carl Hendrix*

Title: Vice President

Date: 8/7/2013

Accepted by: _____

Title: _____

Date: _____ 275

TIMBERLAKE CONSTRUCTION COMPANY, INC.

TCI JOB # 1224
Sara Road Elementary
PROPOSED CHANGE SUMMARY

DATE: 8/20/2013

PROPOSED CHANGE # 120

CHANGE DESCRIPTION: Price to change condensate lines at gym roof top units. Current design called for condensate lines to be installed to nearest roof drain. The nearest roof drain exits on a sidewalk on the north side of the gym. The City of OKC will not allow condensate lines to flow over sidewalks due to their code requirements. We relocated the condensate lines for these four roof top units to another roof drain that ties into the underground storm water.

ADDITIONAL TIME REQUESTED DUE TO THIS CHANGE:

#	ITEM CODE	DESCRIPTION	MATERIAL	LABOR	SUB	EQUIPMENT	TOTALS
1		Relocate condensate lines at Gym	\$327.51	\$346.41	\$81.47		\$755.39
2							\$0.00
3							\$0.00
4							\$0.00
5							\$0.00
6							\$0.00
7							\$0.00
8							\$0.00
9							\$0.00
10							\$0.00
11							\$0.00
12							\$0.00
13							\$0.00
14							\$0.00
15							\$0.00
16							\$0.00
17							\$0.00
18							\$0.00
19							\$0.00
20							\$0.00
21							\$0.00
22							\$0.00
23							\$0.00
24							\$0.00
		CATEGORY TOTALS	\$327.51	\$346.41	\$81.47	\$0.00	\$755.39
	0.0000%	SALES TAX	\$0.00	N/A	N/A	\$0.00	\$0.00
	38.4400%	LABOR BURDEN	N/A	\$0.00	N/A	N/A	\$0.00
	0.8800%	SUB BONDS	N/A	N/A	\$6.65	N/A	\$6.65
		SUBTOTALS	\$327.51	\$346.41	\$88.12	\$0.00	\$762.04
					0.2400%	SUB LIABILITY	\$1.83
					0.8300%	BONDS	\$6.32
					4.0000%	OH&P	\$30.48
					0.3200%	Safety	\$2.44
					0.2200%	Shop Dray	\$1.68
					0.2500%	Cleanup	\$1.91
		TOTAL CHANGE ORDER					\$806.69

SPECIAL NOTES AND COMMENTS ABOUT THIS CHANGE:

Special notes and comments about this change:

Additional time requested due to this change: 0 Days

The work described above represents a change in scope and price and will adjust the time to the original contract as indicated. Timberlake Construction is directed to proceed with this work ASAP and the contract sum will be adjusted by change order within 15 day, or as agreed by the owner/contractor.

AUTHORIZING SIGNATURE

OWNER

AUTHORIZING SIGNATURE

TIMBERLAKE CONSTRUCTION

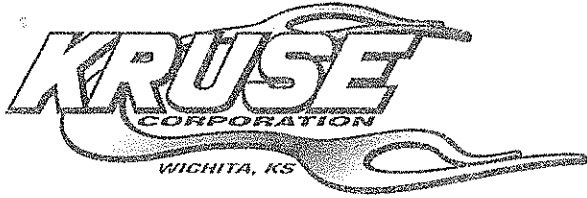

3636 North Topeka
Wichita, Kansas 67219

P. 316-838-7885
F. 316-832-2876

CHANGE REQUEST ESTIMATE FORM

DATE: 8/12/2013

C.R. NO.: 70

PROJECT: Sara Road Elementary School

PROJECT NO.: A2-095

DESCRIPTION OF CHANGE: Rework condensate lines on roof
per Timberlake Construction direction

				Sub Totals
LABOR AND EXPENSES:				
SM Shop Labor		Hours@	\$48.30	\$0.00
SM Field Labor		Hours@	\$48.30	\$0.00
SM Field Labor (Overtime)		Hours@	\$66.57	\$0.00
Piping Labor	6	Hours@	\$50.27	\$301.62
Piping Labor (Overtime)		Hours@	\$68.44	\$0.00
Estimate Preparation	0.25	Hours@	\$58.50	\$14.63
Field Supervision		10% of Field Labor		\$30.16
Cartage/Handling		Hours@	\$30.00	\$0.00
Sheetmetal Shop Facility		25%of Shop Labor		\$0.00
TOTAL COST-LABOR:				\$346.41
PURCHASE EQUIP. AND MATERIALS:				
Equipment:	N/A			
Materials:	Sch. 80 PVC pipe, fittings, roof blocks, etc- HAJOCA			\$327.51
TOTAL COST-EQUIPMENT AND MATERIALS:				\$327.51
EQUIPMENT RENTAL:				
	N/A			
TOTAL COST- EQUIPMENT RENTAL:				\$0.00
SUBCONTRACTORS:				
	N/A			
TOTAL COST-SUBCONTRACTORS:				\$0.00
TOTAL COSTS:				
Overhead	5%			\$673.92
Profit	5%			\$33.70
Taxes	7.3%	Tax Exempt enter 0, Taxable enter 1	<input type="text" value="0"/>	\$33.70
Bond	1.9%	Not required enter 0, required enter 1	<input type="text" value="1"/>	\$0.00
				\$14.08
TOTAL CHANGE ESTIMATE:				\$755.39

EXCLUSIONS:

Site or utility work of any kind	Roof Cut / Patch / Removal
Electrical work of any kind	Structural steel work or supports of any kind
Plumbing work of any kind	
Fire protection work of any kind	
Ceiling or wall demo/repair	

HAJOCA WICHITA
 711 N HYDRAULIC ST
 WICHITA KS 67214-3470
 316-262-2471 Fax 316-262-1813

**** INVOICE ****
(Reprint)

INVOICE DATE	INVOICE NUMBER
08/02/13	S008220117.001
REMIT TO: HAJOCA CORPORATION DEPT 0937 PO BOX 120937 DALLAS TX 75312-0937	PAGE NO. 1

BILL TO:
 KRUSE CORPORATION
 3636 N TOPEKA
 WICHITA, KS 67219

SHIP TO:
 SARA ROAD ELEMENTARY A2095
 c/o KRUSE CORPORATION
 3600 S SARA RD
 YUKON, OK 73099

CUSTOMER NUMBER	CUSTOMER ORDER NUMBER	CUSTOMER RELEASE NUMBER	FRT	ORDERED BY	
150-503362AS	A-2095	CO-80	N	KENT	
SALESPERSON	WRITER	SHIP VIA	TERMS	SHIP DATE	ORDER DATE
Hilary Perkins	Deandre King	WC WILL CALL	NET 30 DAYS	08/02/13	08/02/13
DESCRIPTION	ORDER QTY	SHIP QTY	NET UNIT PRICE	EXTENSION	
2X20 SCH80 PE PVC GREY PLAS PIPE	140'	140'	1.081ft	151.36	
829-020 2 SCH80 SXS PVC CPLG	4ea	4ea	2.761ea	11.04	
801-020 2 SCH80 SXSXS PVC TEE	3ea	3ea	7.900ea	23.70	
837-249 2X1 SCH80 SPGXS PVC FLUSH BUSH	3ea	3ea	3.165ea	9.49	
ROOF TOP BLOX RTB-1 ADJ PIPING SUPPORT	10ea	10ea	8.680ea	86.80	
835-020 2 SCH80 SXF PVC FEM ADPT	1ea	1ea	7.996ea	8.00	
850-020 2 SCH80 MALE PVC THRD PLUG	1ea	1ea	2.485ea	2.48	
IPS 10223 P-70 QT PURPLE LOW VOC PVC & CPVC PRIMER	1ea	1ea	16.296ea	16.30	
MSDS SHEETS ON FILE					
IPS 10119 711 QT GRAY HVY BODY PVC CEMENT	1ea	1ea	18.336ea	18.34	
MSDS SHEETS ON FILE					
MSDS Sheet# ADHESIVES Required					

This invoice is governed by, and incorporates by reference, Hajooca Corporation's Sales Order Terms and Conditions found at <http://www.hajoca.com/sales-order-terms-and-conditions/> and the terms and conditions of our credit application. By your signature below and/or acceptance of the products described herein, you acknowledge having read and agree to be bound by such terms and conditions

Subtotal	327.51
S&H CHGS	0.00
Sales Tax	23.42
Amount Due	350.93

** Reprint ** Reprint ** Reprint **

HAJOCA WICHITA
 711 N HYDRAULIC ST
 WICHITA KS 67214-3470
 316-262-2471 Fax 316-262-1813

**** INVOICE ****

INVOICE DATE	INVOICE NUMBER
08/09/13	S008220117.002
REMIT TO: HAJOCA CORPORATION DEPT 0937 PO BOX 120937 DALLAS TX 75312-0937	PAGE NO. 1

BILL TO:
 KRUSE CORPORATION
 3636 N TOPEKA
 WICHITA, KS 67219

SHIP TO:
 SARA ROAD ELEMENTARY A2095
 c/o KRUSE CORPORATION
 3600 S SARA RD
 YUKON, OK 73099

CUSTOMER NUMBER	CUSTOMER ORDER NUMBER	CUSTOMER RELEASE NUMBER	FRT	ORDERED BY	
150-503362AS	A-2095	CO-80	N	KENT	
SALESPERSON	WRITER	SHIP VEA	TERMS	SHIP DATE	ORDER DATE
Hilary Perkins	Deandre King	OT3 OUR TRK3	NET 30 DAYS	08/09/13	08/02/13
DESCRIPTION	ORDER QTY	SHIP QTY	NET UNIT PRICE	EXTENSION	
BLOX SCB-07 SECURING BRACKETS 2 PER SET	10ea	10ea	6.850ea	68.50	

This invoice is governed by, and incorporates by reference, Hajooca Corporation's Sales Order Terms and Conditions found at <http://www.hajoca.com/sales-order-terms-and-conditions/> and the terms and conditions of our credit application. By your signature below and/or acceptance of the products described herein, you acknowledge having read and agree to be bound by such terms and conditions

Subtotal	68.50
S&H CHGS	0.00
Sales Tax	4.90
Amount Due	73.40

TIMBERLAKE CONSTRUCTION COMPANY, INC.

TCI JOB # 1224
Sara Road Elementary
PROPOSED CHANGE SUMMARY

DATE: 8/21/2013

PROPOSED CHANGE # 121

CHANGE DESCRIPTION: Price to credit back dumpster screen allowance established at project start up.

ADDITIONAL TIME REQUESTED DUE TO THIS CHANGE:

#	ITEM CODE	DESCRIPTION	MATERIAL	LABOR	SUB	EQUIPMENT	TOTALS
1		Dumpster screen allowance			(\$2,500.00)		(\$2,500.00)
2							\$0.00
3							\$0.00
4							\$0.00
5							\$0.00
6							\$0.00
7							\$0.00
8							\$0.00
9							\$0.00
10							\$0.00
11							\$0.00
12							\$0.00
13							\$0.00
14							\$0.00
15							\$0.00
16							\$0.00
17							\$0.00
18							\$0.00
19							\$0.00
20							\$0.00
21							\$0.00
22							\$0.00
23							\$0.00
24							\$0.00
		CATEGORY TOTALS	\$0.00	\$0.00	(\$2,500.00)	\$0.00	(\$2,500.00)
	0.0000%	SALES TAX	\$0.00	N/A	N/A	\$0.00	\$0.00
	38.4400%	LABOR BURDEN	N/A	\$0.00	N/A	N/A	\$0.00
	0.8800%	SUB BONDS	N/A	N/A	\$0.00	N/A	\$0.00
		SUBTOTALS	\$0.00	\$0.00	(\$2,500.00)	\$0.00	(\$2,500.00)
				0.2400%	SUB LIABILITY		\$0.00
				0.8300%	BONDS		\$0.00
				4.0000%	OH&P		\$0.00
				0.3200%	Safety		\$0.00
				0.2200%	Shop Dray		\$0.00
				0.2500%	Cleanup		\$0.00
		TOTAL CHANGE ORDER					(\$2,500.00)

SPECIAL NOTES AND COMMENTS ABOUT THIS CHANGE:
Special notes and comments about this change:

Additional time requested due to this change: 0 Days

The work described above represents a change in scope and price and will adjust the time to the original contract as indicated. Timberlake Construction is directed to proceed with this work ASAP and the contract sum will be adjusted by change order within 15 day, or as agreed by the owner/contractor.

AUTHORIZING SIGNATURE
OWNER

AUTHORIZING SIGNATURE
TIMBERLAKE CONSTRUCTION

TIMBERLAKE CONSTRUCTION COMPANY, INC.

TCI JOB # 1224
Sara Road Elementary
PROPOSED CHANGE SUMMARY

DATE: 8/28/2013

PROPOSED CHANGE # 124

CHANGE DESCRIPTION: Price to provide Hobart VCM kitchen equipment. This was deleted during the VE and the school's kitchen staff stated this piece of equipment was required.

ADDITIONAL TIME REQUESTED DUE TO THIS CHANGE:

#	ITEM CODE	DESCRIPTION	MATERIAL	LABOR	SUB	EQUIPMENT	TOTALS
1		Discount Bakery			\$4,099.00		\$4,099.00
2							\$0.00
3							\$0.00
4							\$0.00
5							\$0.00
6							\$0.00
7							\$0.00
8							\$0.00
9							\$0.00
10							\$0.00
11							\$0.00
12							\$0.00
13							\$0.00
14							\$0.00
15							\$0.00
16							\$0.00
17							\$0.00
18							\$0.00
19							\$0.00
20							\$0.00
21							\$0.00
22							\$0.00
23							\$0.00
24							\$0.00
CATEGORY TOTALS			\$0.00	\$0.00	\$4,099.00	\$0.00	\$4,099.00
0.0000%	SALES TAX		\$0.00	N/A	N/A	\$0.00	\$0.00
38.4400%	LABOR BURDEN		N/A	\$0.00	N/A	N/A	\$0.00
0.8800%	SUB BONDS		N/A	N/A	\$36.07	N/A	\$36.07
SUBTOTALS			\$0.00	\$0.00	\$4,135.07	\$0.00	\$4,135.07
					0.2400% SUB LIABILITY		\$9.92
					0.8300% BONDS		\$34.32
					4.0000% OH&P		\$165.40
					0.3200% Safety		\$13.23
					0.2200% Shop Dray		\$9.10
					0.2500% Cleanup		\$10.34
TOTAL CHANGE ORDER							\$4,377.39

SPECIAL NOTES AND COMMENTS ABOUT THIS CHANGE:

Special notes and comments about this change:

Additional time requested due to this change: 0 Days

The work described above represents a change in scope and price and will adjust the time to the original contract as indicated. Timberlake Construction is directed to proceed with this work ASAP and the contract sum will be adjusted by change order within 15 day, or as agreed by the owner/contractor.

AUTHORIZING SIGNATURE
OWNER

AUTHORIZING SIGNATURE
TIMBERLAKE CONSTRUCTION

Discount Bakery Equipment

PO Box 181
 Wayland, MI 49348
 877-331-BAKE (2253)

Invoice

Date	Invoice #
8/8/2013	7545

PAID
 08/08/2013

Bill To
Timberlake Construction PO BOX18297 Oklahoma City, OK 73154 United States

Ship To
3600 S Fara Rd Yukon, OK 73099 United States

P.O. Number	Terms	Rep	Ship	Via	F.O.B.
1224	Am Express	DR	8/8/2013	R&L	

Quantity	Description	Price Each	Amount
1.00	Hobart	3,950.00	3,950.00T
1.00	Freight	149.00	149.00

jerose@discountbakeryequip.com	Subtotal	\$4,099.00
www.discountbakeryequip.com		
Total		\$4,099.00

Equipment will remain property of Discount Bakery Equipment until paid in full.

MEMO

To: Sean McDaniel, Superintendent *SM 8/20/13*
From: Jeff Woodard, Director of Bonds/Construction
Date: August 30, 2013
Re: MidHigh Renovation Change Order #8

Respectfully request that the Board discuss, consider, and/or act upon approval of the following change order from Timberlake Construction for the MidHigh Renovation:

- *PC#67- Hood work in Rm179 - \$4,822
- *PC#79- Time and materials to run conduit/power in underground raceway per RFI#49 - \$1,443.00
- *PC#82- Add sidewalk from media center to flat canopy section - \$2,114.00
- *PC#83- Relocate thermostat in kitchen per RFI#75, and add return air grille in Rm132 per RFI#76 - \$2,096.00

This will be a net DECREASE to the contingency of **\$10,475.00**

AW
8/20/13



AIA Document G701™ - 2001

Change Order

PROJECT <i>(Name and address):</i> Mustang Mid-High Renovation - 5th & 6th Grade Center 430 Forster Drive Mustang, Oklahoma 73064	CHANGE ORDER NUMBER: 008 DATE: 8-21-13	OWNER: <input checked="" type="checkbox"/> ARCHITECT: <input checked="" type="checkbox"/> CONTRACTOR: <input checked="" type="checkbox"/> FIELD: <input type="checkbox"/> OTHER: <input type="checkbox"/>
TO CONTRACTOR <i>(Name and address):</i> Timberlake Construction Co., Inc. PO Box 18297 Oklahoma City, OK 73154	ARCHITECT'S PROJECT NUMBER: CONTRACT DATE: 4-26-12 CONTRACT FOR: General Construction	

THE CONTRACT IS CHANGED AS FOLLOWS:

(Include, where applicable, any undisputed amount attributable to previously executed Construction Change Directives)

This change order will be a net deduct to the Owner Contingency in the amount of \$10,475.00 as follows:

1. PC #67 - Hood work in Room 179 - \$4,822.00.
2. PC #79 - Time and materials to run conduit/power in underground raceway per RFI #49 - \$1,443.00.
3. PC #82 - Add sidewalk from Media Center to flat canopy section - \$2,114.00.
4. PC #83 - Relocate thermostat in kitchen per RFI #75, and add return air grille in Rm 132 per RFI #76 - \$2,096.00.

The original Guaranteed Maximum Price was	\$ 7,299,977.36
The net change by previously authorized Change Orders	\$ 0.00
The Guaranteed Maximum Price prior to this Change Order was	\$ 7,299,977.36
The Guaranteed Maximum Price will be increased by this Change Order in the amount of	\$ 0.00
The new Guaranteed Maximum Price including this Change Order will be	\$ 7,299,977.36

The Contract Time will be increased by Zero (0) days.

The date of Substantial Completion as of the date of this Change Order therefore is

NOTE: This Change Order does not include changes in the Contract Sum, Contract Time or Guaranteed Maximum Price which have been authorized by Construction Change Directive until the cost and time have been agreed upon by both the Owner and Contractor, in which case a Change Order is executed to supersede the Construction Change Directive.

NOT VALID UNTIL SIGNED BY THE ARCHITECT, CONTRACTOR AND OWNER.

<u>MA+ Architecture</u> ARCHITECT <i>(Firm name)</i>	<u>Timberlake Construction Co., Inc.</u> CONTRACTOR <i>(Firm name)</i>	<u>Mustang Public Schools</u> OWNER <i>(Firm name)</i>
4000 North Classen, Suite 100N, Oklahoma City, OK 73118	PO Box 18297, Oklahoma City, OK 73154	906 S Heights Drive, Mustang, OK 73064
ADDRESS	ADDRESS	ADDRESS
<u></u> BY <i>(Signature)</i>	<u></u> BY <i>(Signature)</i>	<u></u> BY <i>(Signature)</i>
<u>08/26/13</u> (Typed name)	<u>Robert Renshaw Jr.</u> (Typed name)	<u>Sean McDaniel</u> (Typed name)
DATE	DATE	DATE

TIMBERLAKE CONSTRUCTION COMPANY, INC.

TCI JOB # 1229
Mustang Mid High 5th & 6th Grade Center Renovation
PROPOSED CHANGE SUMMARY

DATE: 7/1/13

PROPOSED CHANGE #67

CHANGE DESCRIPTION: Pricing below is for hood work in room 179 to provide new hood. The Owner will provide the range/stove combo unit and mechanical and electrical trades are to hook up. The ansul system will be included in this work.

ADDITIONAL TIME REQUESTED DUE TO THIS CHANGE:

#	ITEM CODE	DESCRIPTION	MATERIAL	LABOR	SUB	EQUIPMENT	TOTALS
1		Bass Electric			\$0.00		\$0.00
2		United Mechanical			\$4,309.28		\$4,309.28
3		OK Roofing			\$205.70		\$205.70
4							\$0.00
5							\$0.00
6							\$0.00
7							\$0.00
8							\$0.00
9							\$0.00
10							\$0.00
11							\$0.00
12							\$0.00
13							\$0.00
14							\$0.00
15							\$0.00
16							\$0.00
17							\$0.00
18							\$0.00
19							\$0.00
20							\$0.00
21							\$0.00
22							\$0.00
23							\$0.00
24							\$0.00
CATEGORY TOTALS			\$0.00	\$0.00	\$4,514.98	\$0.00	\$4,514.98
0.0000%	SALES TAX		\$0.00	N/A	N/A	\$0.00	\$0.00
38.4400%	LABOR BURDEN		N/A	\$0.00	N/A	N/A	\$0.00
0.8800%	SUB BONDS		N/A	N/A	\$39.73	N/A	\$39.73
SUBTOTALS			\$0.00	\$0.00	\$4,554.71	\$0.00	\$4,554.71
					0.2400% SUB LIABILITY		\$10.93
					0.8300% BONDS		\$37.80
					4.0000% OH&P		\$182.19
					0.3200% Safety		\$14.58
					0.2200% Shop Dray		\$10.02
					0.2500% Cleanup		\$11.39
TOTAL CHANGE ORDER							\$4,822

SPECIAL NOTES AND COMMENTS ABOUT THIS CHANGE:

Special notes and comments about this change: NONE

Additional time requested due to this change: 0 Days

The work described above represents a change in scope and price and will adjust the time to the original contract as indicated. Timberlake Construction is directed to proceed with this work ASAP and the contract sum will be adjusted by change order within 15 day, or as agreed by the owner/contractor.

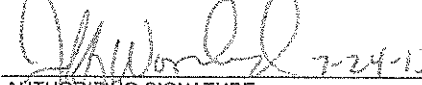

AUTHORIZING SIGNATURE
OWNER

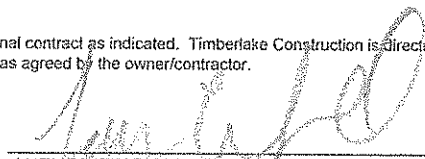

AUTHORIZING SIGNATURE
TIMBERLAKE CONSTRUCTION

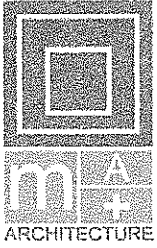

Architect's Supplemental Instruction

DATE: June 10, 2013

TO: Jay Crawford

COMPANY: Timberlake Construction

FROM: Josh Pendleton

PROJECT: Mustang Mid-High Renovation – 5th & 6th Grade Center

JOB #: 1511E67

CONTRACT DATE: April 26, 2012

ASI NO. 027 :

Please find attached detail and schedule for the vent hood to be used over the Owner provided stove in Classroom 179. This vent hood configuration shall replace the previous hood configuration due to the State Fire Marshal Directive for this equipment, effective June 1 2013. This document is attached for reference.

Contractor to provide pricing credit for equipment required in original Contract Documents in cost breakdown.

Kitchen Hood Schedule

MARK TYPE	MANUFACTURER/CAPTURE MODEL NO.	EXHAUST SIZE	CFM	NOTES	HOOD CONTROLLER	AMPS	VOLTAGE	NOTES	AIR SUPPLY CURTAIN	QUANTITY	AIR CURTAIN SIZE	AIR VOLUME/ SP (IN WG)	NOTES
H-1	EXISTING	186"X54"	3500	1	GREENHECK	15	120/60/1	2,3,4	GREENHECK	2	186"X16"	1750	5
KH-2	WALL CANOPY TYPE 1	36"x19.5"	550	1	FACTORY MOUNTED VARIABLE SWITCH	5	120/60/1	3,4					

- NOTE: 1. PROVIDE UL LISTED EXHAUST DUCT.
 2. PROVIDE INTERLOCK TO KITCHEN HOOD EXHAUST FAN EF-5 AND MAKEUP AIR UNITS RTU-2 & 3.
 3. PROVIDE FAN SWITCH, LIGHT SWITCH, AND TEMPERATURE INTERLOCK HEAT SENSOR.
 4. PROVIDE INTERLOCK TO EXISTING GAS SOLENOID, NEW ELECTRICAL SHUNTS AND FIRE SUPPRESSION CONTROLLER.
 5. SUPPLY AIR PLENUM CONSTRUCTED OF 430 STAINLESS AND INSULATED.

KEYED NOTES:

- RTU-12, 13, 14 & 15 AND ALL ASSOCIATED DUCTWORK, GRILLES, PIPING, ECT. TO BE BID UNDER ALTERNATE #1.
- NEW FLOOR GRILLE. CUT EXISTING CONCRETE AND TIE INTO EXISTING UNDERFLOOR DUCT. PATCH CONCRETE TO MATCH EXISTING.
- RELOCATED EXISTING THERMOSTAT.
- REPLACE EXISTING MULTIZONE UNIT WITH NEW. REFER TO DETAILS AND SCHEDULES. REUSE EXISTING MULTIZONE DAMPERS. PROVIDE NEW 4" THICK CONCRETE HOUSEKEEPING PAD. 6" LARGER THAN NEW UNIT FOOTPRINT ON ALL SIDES. BID UNDER ALTERNATE #9.
- PROVIDE RESIDENTIAL HOOD WITH INTEGRAL FIRE PROTECTION SYSTEM. PROVIDE GAS SOLENOID VALVE OR ELECTRICAL SHUNT FOR EXISTING RANGE AND INTERLOCK WITH SYSTEM. PROVIDE PULL STATION. REFER TO KITCHEN HOOD SCHEDULE FOR ADDITIONAL INFORMATION.

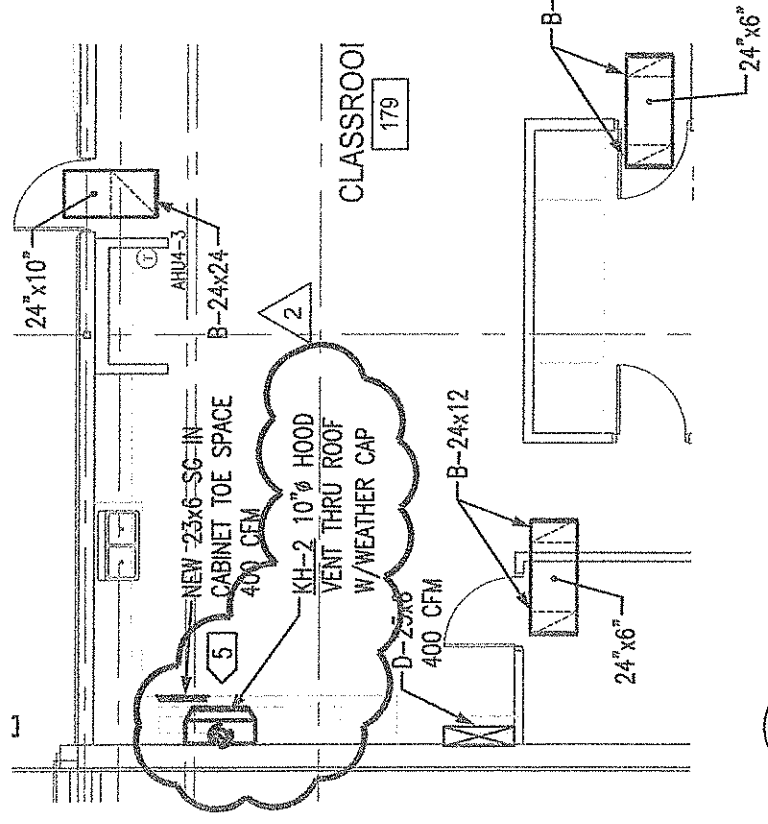

SCALE: 1/8" = 1'-0"
 REFER:

A FIRST FLOOR MECHANICAL PLAN - AREA 2

ASI-27

ACI ALLEN CONSULTING, INC.
 ENGINEERING, PLANNING, ENERGY CONSULTANTS
 NORMAN, OKLAHOMA (405) 447-2292

Mustang Mid-High Renovation
 5th & 6th Grade Center
 Mustang Oklahoma

Project #	186.12
Sheet #	SKM-1
Date	6/6/13
Ref.	M212

Oklahoma State Fire Marshal's Office
Official Interpretation and Code Directive 2013-7

Hood Suppression System Requirements for Cooking Appliances
Used for Warming Purposes Only

Effective June 1, 2013

The guidelines set forth through the codes adopted by the Oklahoma Uniform Building Code Commission and enforced by the Oklahoma State Fire Marshals Office can help to establish the requirements for non-commercial warming devices. This directive is to help simplify and bring clarity as to what is required to be installed.

Any cooking device used to warm foods within an Assembly, Business, Education, Factory, Hazardous, Institutional, Mercantile, Residential, Special Amusement Building, High Rise Buildings, Atriums, High Piled Combustible Storage Areas, Aerosol Storage Uses, Lumber-Wood Structural Panel and Veneer, Underground Buildings, Deep Underground Buildings, Covered Mall Buildings, Residential Aircraft Hangers, and Airport Traffic Control Towers as identified by the International Building Code (IBC) and the International Fire Code (IFC) must adhere to the requirements to the adopted International Building Code Section 903 and the Life Safety Code 101 as it relates to remodels.

In lieu of a commercial hood suppression system being installed over cooking devices used to warm foods only, an alternative hood suppression system shall be acceptable as long as that particular suppression system is in compliance with the 2009 International Mechanical Code (IMC), 2009 International Fire Code (IFC), LC1031(Exhaust Type II Hood with an integrated fire suppression system for domestic cooking appliances in commercial applications), UL Subject 300A (Extinguishing System Units for residential top cooking surfaces), and UL 507 (Standard for Electric Fans). An ICC Evaluation Service Report is required to confirm compliance.

Upon the activation of the hood suppression system the exhaust fan shall turn on if in the off position, shall remain on if in the on position, shall shunt all gas and electrical systems to the cooking equipment, shall have a pull station provided for manual activation, shall sound a local alarm once activated, and shall be tied to the fire alarm system if present.

We would require that a complete set of plans be submitted to our office for review of all buildings that fall within our jurisdiction. Provide the ICC Evaluation Service report.

It is our hope that we can work together to develop new sites while remaining committed to maintaining the utmost level of life safety by making Oklahoma structures as safe as possible through congruent code enforcement.

Robert Doke
State Fire Marshal



PROPOSED CHANGE ORDER - OFFICE COPY

CCN # ASI 027 VENT HOOD
Date: 7/1/2013
Project Name: MUSTANG MID-HIGH
Project Number: RFP# 007
Page Number: 1

Client Address:

Work Description

We reserve the right to correct this quote for errors and omissions.

This quote covers direct costs only and we reserve the right to claim for impact and consequential costs.

This price is good for acceptance within 10 days from the date of receipt.

We request a time extension of 3 days.

We will supply and install all materials, labor, and equipment as per your instructions on **CCN # ASI 027 VENT HOOD**.

FIELD CODES

Tab - distance in inches that text following the field code will be indented from left
Current date 7/1/2013
7/1/2013 - current date with tab from the left included

Database Name
Database Number (folder name) BASSELECTRICLLC
Database Address (path and folder name) C:\ProgramData\Accubid\Databases\BASSELECTRICLLC
Project Name MUSTANG MID-HIGH 5TH & 6TH GRADE CENTER
Project Number (folder name) RFP# 007
Project Address (path and folder name) C:\ProgramData\Accubid\CODATA\MUSTANG MID-HIGH 5TH & 6TH GRADE CENTER.co10
Project Contract Number
File name of PDF attached to email ASI 027 VENT HOOD.pdf

My Company Name
My Company Address Line 1
My Company Address Line 2
My Company City
My Company State or Province
My Company Country
My Company Zip Code or Postal Code
My Company Telephone number
My Company Fax number
My Company Contact name
My Company E-mail

Client Address Site Name
Client Address Address Line 1
Client Address Address Line 2
Client Address City
Client Address State or Province
Client Address Country
Client Address Zip Code or Postal Code
Client Address Telephone number
Client Address Fax number
Client Address Contact name
Client Address E-mail

FROM JOB INFO SCREEN

ORIGINAL - OFFICE COPY

289

PROPOSED CHANGE ORDER - OFFICE COPY

Client Address:

CCN # ASI 027 VENT HOOD
 Date: 7/1/2013
 Project Name: MUSTANG MID-HIGH
 Project Number: RFP# 007
 Page Number: 2

Job (CCN) Number ASI 027 VENT HOOD
 Job (CCN) Number Header CCN #
 Job (CCN) Description
 Job (CCN) Notes
 Job (CCN) Status Pending

Job (CCN) Date 7/1/2013
 Job (CCN) Date Header CCN Date
 Last Saved Date 7/1/2013
 Received Date 7/1/2013
 Due Date 7/1/2013
 Start Date 7/1/2013
 CO Date
 CO Number

Reference Column 1
 Reference Column 1 Header Ref #1
 Reference Column 2
 Reference Column 2 Header Ref #2
 Reference Column 3
 Reference Column 3 Header Ref #3
 Reference Column 4
 Reference Column 4 Header Ref #4
 Reference Column 5
 Reference Column 5 Header Ref #5
 Reference Column 6
 Reference Column 6 Header Ref #6

FROM JOB SCREENS

Labor column used in Extension 3

FROM TOTALS

Selling Price 619.64
 Final Price (includes Global Tax) 619.64

Itemized Breakdown

Description	Qty	Trade Price	Disc %	Link Price	Cost Adj %	Net Cost	Adj %
#12 THHN	100	276.56	59.29	0.00	0.000	112.58	0.000
50A 2P BREAKER BOLT-ON	1	51.44	19.88	0.00	0.000	41.22	0.000
Totals							

Description	Qty	Net Price	U	Total Mat.	Labor	U	Total Hrs.
#12 THHN	100	276.56	M	27.66	6.92	M	0.69
50A 2P BREAKER BOLT-ON	1	51.44	E	51.44	0.37	E	0.37
Totals				79.10			1.06

Summary

General Materials		79.10
DISTRIBUTION	(\$65.00 + \$0.00)	65.00
FIRE ALARM	(\$200.00 + \$0.00)	200.00
Total Material		344.10
JOURNEYMAN	(4.00 Hrs @ (\$42.00 + \$0.00))	168.00
		290

ORIGINAL - OFFICE COPY

PROPOSED CHANGE ORDER - OFFICE COPY

Client Address:

CCN # **ASI 027 VENT HOOD**
Date: **7/1/2013**
Project Name: **MUSTANG MID-HIGH**
Project Number: **RFP# 007**
Page Number: **3**

Summary (Cont'd)

Subtotal		512.10
Overhead	(@ 10.000 %)	51.21
Markup	(@ 10.000 %)	56.33
Subtotal		619.64
Final Amount		\$619.64

Cost Breakdown	Total (\$)
Material Cost	317.48
Direct Labor Cost	168.00
Total Cost	485.48



PROJECT: MUSTANG MID HIGH SCHOOL.
LOCATION: MUSTANG OK
OWNER: MUSTANG PUBLIC SCHOOLS
ARCHITECT: MEYER.

Ok. Lic. # 80000327

WE PROPOSE AND AGREE TO FURNISH ALL THE NECESSARY LABOR AND MATERIAL TO INSTALL, DESCRIBED AS HEREIN, THE FOLLOWING.

ASI 027

- 1- FURNISH 1- EACH GALVANIZED SHEET METAL VENT FLASHING.
- 2- INSTALL FLASHING AT LOCATION MARKED BY OTHERS, SEAL AND FLASH TO THE ROOF PER MANUFACTURE STANDARD DETAILS.

TOTAL COST. \$205.70

TOTAL MATERIALS.	65.00
LABOR COST, &	
LABOR BURDEN	105.00

	170.00
OH & P	35.70

TOTAL	\$ 205.70

WE EXCLUDE. METAL DECK CUT.

- I. ALL BUILT IN ITEMS TO BE FURNISHED FOB JOBSITE FOR INSTALLATION BY OTHERS.
- II. WHERE WE ARE TO FURNISH MAINTENANCE GUARANTEE OR SURETY BOND, IT IS AGREED THAT OUR REGULAR FORMS WILL BE ACCEPTABLE.
- III. ALL FACTS ARE COVERED IN THIS PROPOSAL AND NO VERBAL AGREEMENT SHALL BE RECOGNIZED.
- IV. THIS PROPOSAL IS SUBJECT TO CANCELLATION BY US WITHIN TEN DAYS AFTER THE GENERAL CONTRACT IS AWARDED, UNLESS IT IS ACCEPTED BY BOTH PARTIES BEFORE THAT DATE AND APPROVED BY OUR OFFICE.

JULY 2, 2013

YOUR ACCEPTANCE OF THIS PROPOSAL WILL CONSTITUTE A CONTRACT.

ARTURO MERINO.

DATE: _____

BY: _____

NAME: _____

OKLAHOMA ROOFING & SHEET METAL, LLC
1708 S. LOWRY AVENUE
OKLAHOMA CITY, OKLAHOMA 73129

COMPANY: _____

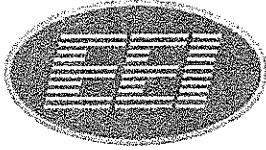

Engineered Equipment Inc.

PROPOSAL SCOPE

June 11, 2013

TO: United Mechancial/Patrick

RE: Mustang Mid High 5th & 6th Renov.

Patrick,
EEI is pleased to offer the following equipment for your use on this project:

- 1. Denlar D1030-IE-DF-MPK Kitchen Hood w/Fire Suppression System
Qty(1) to include:
 - Inline Top Discharge
 - Electrical Box
 - 10" Inline Fan
 - Manual Pull Kit
 - Guardian UL300a Fire Suppression System

PRICE: \$ 4162.00

Specifically Excluding: (Inspection by Fire Marshall)

- Starters
- Filters
- Thermostats/CO2 Sensors
- Plenums
- Round Manual Balancing Dampers/Control Dampers
- Loose Hot Water Coils
- Motorized Dampers
- Temperature Sensors
- Spiral Duct (Unless Noted Above)
- P.E. Switch
- Coating Finishes Unless Noted Above
- Smoke Detectors
- Switches/Actuators
- Hoods
- Time Clock
- Flue/Vent Piping
- Installation
- Sleeves and Access Doors
- Fire Dampers Unless Noted on M Sheets
- Vibration Isolation/Seismic
- Thimbles/Stacks
- VFD's (unless noted above)
- DDC Controls
- Any Item Listed Above

Equipment is offered FOB factory with full freight allowed to the job site. Price does not include labor or installation, extended warranties unless specifically noted above, or applicable taxes of any kind. Any taxes that apply will be added. Standard manufacturer's warranty applies and is parts-only unless stated otherwise. Quotation is good for 45 days. This quotation is based upon payment terms 'net 30 days' with prior credit approval (EEI standard terms and conditions apply).

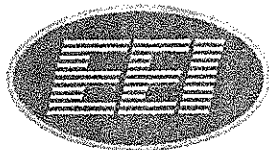

Engineered Equipment Inc.

Should we be awarded this project, please address all purchase orders to *Engineered Equipment, Inc., 4601 N. Santa Fe Ave, Oklahoma City, OK 73118*. In lieu of formal purchase order please sign and return your acceptance of our proposal as listed above.

ACCEPTED

Sincerely,

Signature: _____

Title: _____

Company Name: _____

Date: _____

Penny Allison

Phone Number: _____

ENGINEERED EQUIPMENT INC.

Fax: _____

Email address: _____

TIMBERLAKE CONSTRUCTION COMPANY, INC.

TCI JOB # 1229
Mustang Mid High 5th & 6th Grade Center Renovation
PROPOSED CHANGE SUMMARY

DATE: 7/1/13

PROPOSED CHANGE #67

CHANGE DESCRIPTION: Pricing below is for hood work in room 179 to provide new hood. The Owner will provide the range/stove combo unit and mechanical and electrical trades are to hook up. The ansul system will be included in this work.
Bass pricing was for shunt tripping the oven there was some extra cost on f/A for hood

*RELEASE EVERYTHING EXCEPT BASS
ASK FOR POSSIBLE REVISION*

ADDITIONAL TIME REQUESTED DUE TO THIS CHANGE:

#	ITEM CODE	DESCRIPTION	MATERIAL	LABOR	SUB	EQUIPMENT	TOTALS
1		Bass Electric			\$619.64		\$619.64
2		United Mechanical			\$4,309.28		\$4,309.28
3		OK Roofing			\$205.70		\$205.70
4							\$0.00
5							\$0.00
6							\$0.00
7							\$0.00
8							\$0.00
9							\$0.00
10							\$0.00
11							\$0.00
12							\$0.00
13							\$0.00
14							\$0.00
15							\$0.00
16							\$0.00
17							\$0.00
18							\$0.00
19							\$0.00
20							\$0.00
21							\$0.00
22							\$0.00
23							\$0.00
24							\$0.00
CATEGORY TOTALS			\$0.00	\$0.00	\$5,134.62	\$0.00	\$5,134.62
0.0000%	SALES TAX		\$0.00	N/A	N/A	\$0.00	\$0.00
38.4400%	LABOR BURDEN		N/A	\$0.00	N/A	N/A	\$0.00
0.8800%	SUB BONDS		N/A	N/A	\$45.18	N/A	\$45.18
SUBTOTALS			\$0.00	\$0.00	\$5,179.80	\$0.00	\$5,179.80
					0.2400% SUB LIABILITY		\$12.43
					0.8300% BONDS		\$42.99
					4.0000% OH&P		\$207.19
					0.3200% Safety		\$16.58
					0.2200% Shop Dray		\$11.40
					0.2500% Cleanup		\$12.95
TOTAL CHANGE ORDER							\$5,483

SPECIAL NOTES AND COMMENTS ABOUT THIS CHANGE:

Special notes and comments about this change: NONE

Additional time requested due to this change: 0 Days

The work described above represents a change in scope and price and will adjust the time to the original contract as indicated. Timberlake Construction is directed to proceed with this work ASAP and the contract sum will be adjusted by change order within 15 day, or as agreed by the owner/contractor.

[Signature] 07-17-13
AUTHORIZING SIGNATURE
OWNER

[Signature]
AUTHORIZING SIGNATURE
TIMBERLAKE CONSTRUCTION

TIMBERLAKE CONSTRUCTION COMPANY, INC.

TCI JOB # 1229
Mustang Mid High 5th & 6th Grade Center Renovation
PROPOSED CHANGE SUMMARY

DATE: 7/19/13

PROPOSED CHANGE #79

CHANGE Pricing below is per RFI #49 which stated that the existing power that feeds the food service was to be reused in the underground raceway.
DESCRIPTION: Unfortunately, this line was 'frozen'. Price below was agreed to do on T&M to run the conduits/power overhead per the response which is attached.

ADDITIONAL TIME REQUESTED DUE TO THIS CHANGE:

#	ITEM CODE	DESCRIPTION	MATERIAL	LABOR	SUB	EQUIPMENT	TOTALS
1		Bass Electric			\$1,351.05		\$1,351.05
2							\$0.00
3							\$0.00
4							\$0.00
5							\$0.00
6							\$0.00
7							\$0.00
8							\$0.00
9							\$0.00
10							\$0.00
11							\$0.00
12							\$0.00
13							\$0.00
14							\$0.00
15							\$0.00
16							\$0.00
17							\$0.00
18							\$0.00
19							\$0.00
20							\$0.00
21							\$0.00
22							\$0.00
23							\$0.00
24							\$0.00
CATEGORY TOTALS			\$0.00	\$0.00	\$1,351.05	\$0.00	\$1,351.05
0.0000%	SALES TAX	\$0.00	N/A	N/A	\$0.00		\$0.00
38.4400%	LABOR BURDEN	N/A	\$0.00	N/A	N/A		\$0.00
0.8800%	SUB BONDS	N/A	N/A	\$11.89	N/A		\$11.89
SUBTOTALS			\$0.00	\$0.00	\$1,362.94	\$0.00	\$1,362.94
					0.2400% SUB LIABILITY		\$3.27
					0.6300% BONDS		\$11.31
					4.0000% OH&P		\$54.52
					0.3200% Safety		\$4.36
					0.2200% Shop Dray		\$3.00
					0.2500% Cleanup		\$3.41
TOTAL CHANGE ORDER							\$1,443

SPECIAL NOTES AND COMMENTS ABOUT THIS CHANGE:

Special notes and comments about this change: NONE

Additional time requested due to this change: 0 Days

The work described above represents a change in scope and price and will adjust the time to the original contract as indicated. Timberlake Construction is directed to proceed with this work ASAP and the contract sum will be adjusted by change order within 15 day, or as agreed by the owner/contractor.



AUTHORIZING SIGNATURE
OWNER

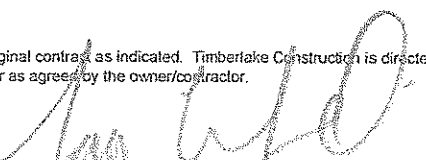

AUTHORIZING SIGNATURE
TIMBERLAKE CONSTRUCTION

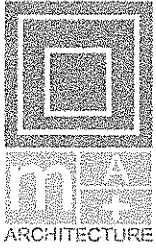

RFI RESPONSE

DATE: April 18, 2013

TO: Ryan Manning

COMPANY: Timberlake Construction, Inc

FROM: Josh Pendleton

PROJECT: Mustang Mid-High Renovation – 5th & 6th Grade Center

JOB #: 1511E67

CONTRACT DATE: April 26, 2012

RFI QUESTION NO. 049 (received 04/10/13):

The power that feeds the food service line was to reuse the underground conduit as a race way. These are 'frozen'. Can these feeds be overhead? What is to be done with the existing holes in the floor--covered over?

RFI ANSWER:

Electrical feeder line can be run overhead. The Contractor is to fasten the electrical lines to the outside surface of the vent hood. No lines are to be installed within the vent hood area. Electrical lines are to be installed with proper conduit per electrical code requirements.

Existing openings located on floor are to be capped with bronze floor cover assemblies appropriately sized for the existing openings.

PROPOSED CHANGE ORDER

Client Address:

CCN # MAIN KITCHEN T&
 Date: 7/19/2013
 Project Name: MUSTANG MID-HIGH
 Project Number: RFP# 007
 Page Number: 2

Job (CCN) Number MAIN KITCHEN T&M
 Job (CCN) Number Header CCN #
 Job (CCN) Description
 Job (CCN) Notes
 Job (CCN) Status Pending

 Job (CCN) Date 7/19/2013
 Job (CCN) Date Header CCN Date
 Last Saved Date 7/19/2013
 Received Date 7/19/2013
 Due Date 7/19/2013
 Start Date 7/19/2013
 CO Date
 CO Number

Reference Column 1
 Reference Column 1 Header Ref #1
 Reference Column 2
 Reference Column 2 Header Ref #2
 Reference Column 3
 Reference Column 3 Header Ref #3
 Reference Column 4
 Reference Column 4 Header Ref #4
 Reference Column 5
 Reference Column 5 Header Ref #5
 Reference Column 6
 Reference Column 6 Header Ref #6

FROM JOB SCREENS

Labor column used in Extension 3

FROM TOTALS

Selling Price 1,351.05
 Final Price (includes Global Tax) 1,351.05

Itemized Breakdown

Description	Qty	Net Price	U	Total Mat.	Labor	U	Total Hrs.
3/4" EMT	30	108.90	C	32.67	8.71	C	2.61
1" EMT	10	181.52	C	18.15	11.08	C	1.11
3/4" EMT STL SS CONN	6	205.54	C	12.33	22.50	C	1.35
1" EMT STL SS CONN	1	353.07	C	3.53	27.00	C	0.27
#12 THHN	240	276.56	M	66.37	10.38	M	2.49
#10 THHN	200	436.16	M	87.23	7.65	M	1.53
B2-1 RED WIRE CONN	32	15.54	C	4.97	9.00	C	2.88
FS 2G BOX 3/4" HUB	1	30.06	E	30.06	0.81	E	0.81
#RCH1GFR WP GFI COVER	3	23.67	E	71.01	0.15	E	0.45
20A 125V GFI DUP REC (SG)	3	1,060.00	C	31.80	33.00	C	0.99
CD1B 3/4" COND CLMP W/ BOLT	6	38.32	C	2.30	14.63	C	0.88
20A 1P BREAKER BOLT-ON	2	22.54	E	45.08	0.22	E	0.44
30A 3P MCB OPEN	1	0.00	E	0.00	1.12	E	1.12
Totals				405.51			16.93

Summary

ORIGINAL

PROPOSED CHANGE ORDER

Client Address:

CCN # **MAIN KITCHEN T&**
Date: **7/19/2013**
Project Name: **MUSTANG MID-HIGH**
Project Number: **RFP# 007**
Page Number: **3**

Summary (Cont'd)

General Materials		405.51
Material Total		405.51
JOURNEYMAN	(16.93 Hrs @ \$42.00)	711.06
Subtotal		1,116.57
Overhead	(@ 10.000 %)	111.66
Markup	(@ 10.000 %)	122.82
Subtotal		1,351.05
Final Amount		\$1,351.05

CONTRACTOR CERTIFICATION

Name: _____
Date: _____
Signature: _____
I hereby certify that this quotation is complete and accurate based on the information provided.

CLIENT ACCEPTANCE

CCN #: MAIN KITCHEN T&M _____
Final Amount: \$1,351.05 _____
Name: _____
Date: _____
Signature: _____
Change Order #: _____
I hereby accept this quotation and authorize the contractor to complete the above described work.

TIMBERLAKE CONSTRUCTION COMPANY, INC.

TCI JOB # 1229
Mustang Mid High 5th & 6th Grade Center Renovation
PROPOSED CHANGE SUMMARY

DATE: 7/30/13

PROPOSED CHANGE #82

CHANGE DESCRIPTION: Pricing below is to add a sidewalk from the Media Center exterior single door to the flat canopy section just south of the media center. This was a request per the Owner's Rep and work was completed yesterday. Attached you will see a picture with the highlighted area in orange.

ADDITIONAL TIME REQUESTED DUE TO THIS CHANGE:

#	ITEM CODE	DESCRIPTION	MATERIAL	LABOR	SUB	EQUIPMENT	TOTALS
1		Connelly Paving			\$1,980.00		\$1,980.00
2							\$0.00
3							\$0.00
4							\$0.00
5							\$0.00
6							\$0.00
7							\$0.00
8							\$0.00
9							\$0.00
10							\$0.00
11							\$0.00
12							\$0.00
13							\$0.00
14							\$0.00
15							\$0.00
16							\$0.00
17							\$0.00
18							\$0.00
19							\$0.00
20							\$0.00
21							\$0.00
22							\$0.00
23							\$0.00
24							\$0.00
CATEGORY TOTALS			\$0.00	\$0.00	\$1,980.00	\$0.00	\$1,980.00
0.0000%	SALES TAX	\$0.00	N/A	N/A	\$0.00		\$0.00
38.4400%	LABOR BURDEN	N/A	\$0.00	N/A	N/A		\$0.00
0.8800%	SUB BONDS	N/A	N/A	\$17.42	N/A		\$17.42
SUBTOTALS			\$0.00	\$0.00	\$1,997.42	\$0.00	\$1,997.42
					0.2400% SUB LIABILITY		\$4.79
					0.8300% BONDS		\$16.58
					4.0000% OH&P		\$79.90
					0.3200% Safety		\$6.39
					0.2200% Shop Dray		\$4.39
					0.2500% Cleanup		\$4.99
TOTAL CHANGE ORDER							\$2,114

SPECIAL NOTES AND COMMENTS ABOUT THIS CHANGE:

Special notes and comments about this change: NONE

Additional time requested due to this change: 0 Days

The work described above represents a change in scope and price and will adjust the time to the original contract as indicated. Timberlake Construction is directed to proceed with this work ASAP and the contract sum will be adjusted by change order within 15 day, or as agreed by the owner/contractor.

8-7-13

AUTHORIZING SIGNATURE
OWNER

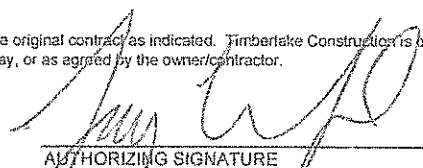

AUTHORIZING SIGNATURE
TIMBERLAKE CONSTRUCTION

From: [Gary Sweeney](#)
To: [James A. Connelly III](#)
Cc: [Ryan Manning](#)
Subject: RE: Mustang Mid High
Date: Tuesday, July 30, 2013 11:36:24 AM

Thank you Andy

From: James A. Connelly III [mailto:andy@connellypaving.com]
Sent: Tuesday, July 30, 2013 11:35 AM
To: Gary Sweeney
Subject: Mustang Mid High

Gary,

The additional sidewalk we poured on the west side of Mustang Mid High per your request will be an add of \$1,980.00

--

Andy Connelly
Connelly Paving Company

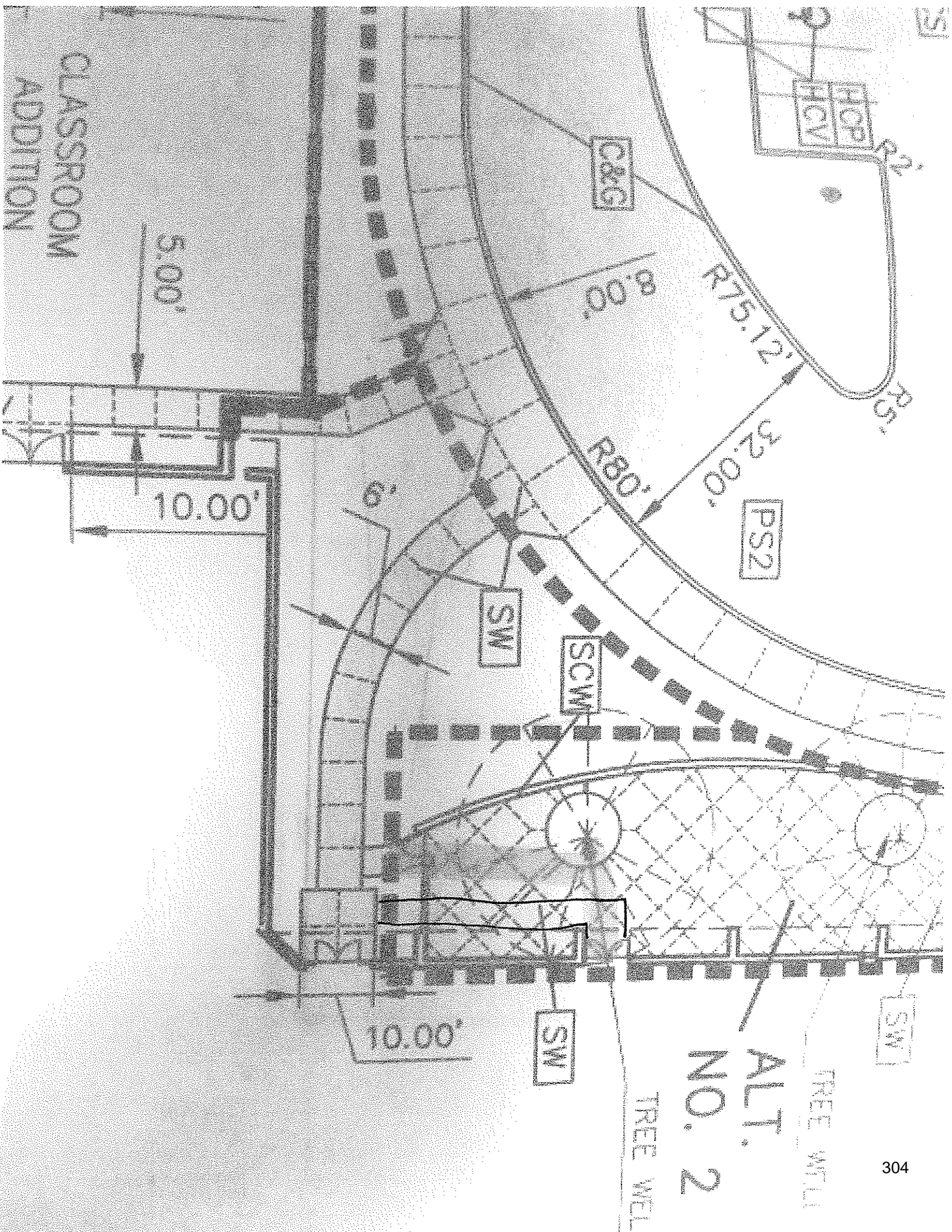

TIMBERLAKE CONSTRUCTION COMPANY, INC.

TCI JOB # 1229
Mustang Mid High 5th & 6th Grade Center Renovation
PROPOSED CHANGE SUMMARY

DATE: 8/1/13

PROPOSED CHANGE #83

CHANGE DESCRIPTION: Pricing below is for RFI #75 to relocate thermostat in kitchen, RFI #76 to add return air grille in room 132, and to install the owner provided ice machine in the nurse station. Ice machine will be plugged into existing outlet. All backup is attached to this PCO.

ADDITIONAL TIME REQUESTED DUE TO THIS CHANGE:

#	ITEM CODE	DESCRIPTION	MATERIAL	LABOR	SUB	EQUIPMENT	TOTALS
1		United(Thermostat)			\$539.38		\$539.38
2		United(Return Air Grille)			\$435.09		\$435.09
3		United(Ice Machine Install)			\$988.45		\$988.45
4							\$0.00
5							\$0.00
6							\$0.00
7							\$0.00
8							\$0.00
9							\$0.00
10							\$0.00
11							\$0.00
12							\$0.00
13							\$0.00
14							\$0.00
15							\$0.00
16							\$0.00
17							\$0.00
18							\$0.00
19							\$0.00
20							\$0.00
21							\$0.00
22							\$0.00
23							\$0.00
24							\$0.00
CATEGORY TOTALS			\$0.00	\$0.00	\$1,962.92	\$0.00	\$1,962.92
0.0000%	SALES TAX		\$0.00	N/A	N/A	\$0.00	\$0.00
38.4400%	LABOR BURDEN		N/A	\$0.00	N/A	N/A	\$0.00
0.8800%	SUB BONDS		N/A	N/A	\$17.27	N/A	\$17.27
SUBTOTALS			\$0.00	\$0.00	\$1,980.19	\$0.00	\$1,980.19
					0.2400% SUB LIABILITY		\$4.75
					0.8300% BONDS		\$16.44
					4.0000% OH&P		\$79.21
					0.3200% Safety		\$6.34
					0.2200% Shop Dray		\$4.56
					0.2500% Cleanup		\$4.95
TOTAL CHANGE ORDER							\$2,096

SPECIAL NOTES AND COMMENTS ABOUT THIS CHANGE:

Special notes and comments about this change: NONE

Additional time requested due to this change: 0 Days

The work described above represents a change in scope and price and will adjust the time to the original contract as indicated. Timberlake Construction is directed to proceed with this work ASAP and the contract sum will be adjusted by change order within 15 day, or as agreed by the owner/contractor.

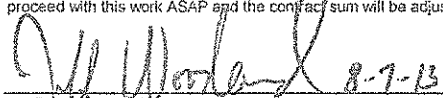
AUTHORIZING SIGNATURE
OWNER

AUTHORIZING SIGNATURE
TIMBERLAKE CONSTRUCTION



PROJECT: Mustang Mid High Renovation
 RFP NO.:
 DESCRIPTION: RFI-75, Relocate RTU-2 T-stat

CHANGE ORDER

JOB NUMBER: 12956
 DATE: 7/31/2013

MATERIAL:					
QTY	SIZE	CODE	DESCRIPTION	COST EA.	TOTAL
1		Lot	Plumbing Material	\$ -	\$ -
1		Lot	Hydronic Material	\$ 50.00	\$ 50.00
1		Lot	Sheetmetal Material	\$ -	\$ -
1		Lot	Plumbing Equipment	\$ -	\$ -
1		Lot	Hydronic Equipment	\$ -	\$ -
1		Lot	Sheetmetal Equipment	\$ -	\$ -
SUB TOTAL:				\$	50.00
SALES TAX:				\$	-
OVERHEAD:				\$	-
PROFIT: 10%				\$	5.00
TOTAL MATERIAL:				\$	55.00

LABOR:				
TYPE	CODE	RATE	HRS	TOTAL
REGULAR HOURS				
PIPE FITTER		\$ 31.08	4	124.32
PLUMBER		\$ 31.08		-
SHEET METAL FIELD		\$ 30.00		-
SHEET METAL SHOP		\$ 30.00		-
FOREMENS RATE		\$ 6.00	2	12.00
TRUCKING LABOR		\$ 25.00	0.4	10.00
OVERTIME (TIME & 1/2)				
PIPE FITTER		\$ 46.62		-
PLUMBER		\$ 46.62		-
SHEET METAL FIELD		\$ 45.00		-
SHEET METAL SHOP		\$ 45.00		-
FOREMENS RATE		\$ 9.32		-
TRUCKING LABOR		\$ 37.50		-
FRINGE BENEFITS				
PIPE FITTER		\$13.22	4	52.88
PLUMBER		\$13.22		-
SHEET METAL FIELD		\$14.28		-
SHEET METAL SHOP		\$14.28		-
LABOR BURDEN				
TOTAL				27.32
TRAVEL PAY		\$65	PER DAY	
COST PER HOUR			\$8.13	
INDIRECT COST ALLOCATION (6%)				
TOTAL				10.42
SUB TOTAL:				\$ 235.94
OVERHEAD:				\$ -
PROFIT: 10%				\$ 23.69
TOTAL LABOR:				\$ 260.63

TOOL AND EQUIPMENT RENTAL:					
QTY	SIZE	CODE	DESCRIPTION	RATE:	TOTAL
1		Lot	Plumbing Other Cost	\$ 200.00	\$ 200.00
1		Lot	Hydronic Other Cost	\$ -	\$ -
1		Lot	Sheetmetal Other Cost	\$ -	\$ -
1		Lot	Excavation	\$ -	\$ -
SUB TOTAL:				\$	200.00
OVERHEAD:				\$	-
PROFIT: 10%				\$	20.00
TOTAL RENTAL:				\$	220.00

SUBCONTRACTS:		
DESCRIPTION:	CODE	TOTAL:
Insulation		\$ -
Excavation		\$ -
Test & Balance		\$ -
SUB TOTAL:		\$ -
OVERHEAD:		\$ -
PROFIT: 5%		\$ -
TOTAL SUB-CONTRACTS:		\$ -

BOND RATE: 0.7%

\$ 3.75

TOTAL CHANGE ORDER:

\$ 539.38

THIS WILL BECOME KNOWN AS CHANGE ORDER NO. 27

CONTRACTOR:

SUBCONTRACTOR:
 UNITED MECHANICAL, INC.

BY: _____

BY: _____

DATE: _____

DATE: July 31, 2013



CHANGE ORDER

PROJECT: Mustang Mid High Renovation
 RFP NO.:
 DESCRIPTION: RFI-76, Add return air grille in room 132

JOB NUMBER: 12956
 DATE: 7/31/2013

MATERIAL:

QTY	SIZE	CODE	DESCRIPTION	COST EA	TOTAL
1		Lot	Plumbing Material	\$ -	\$ -
1		Lot	Hydronic Material	\$ -	\$ -
1		Lot	Sheetmetal Material	\$ 75.00	\$ 75.00
1		Lot	Plumbing Equipment	\$ -	\$ -
1		Lot	Hydronic Equipment	\$ -	\$ -
1		Lot	Sheetmetal Equipment	\$ -	\$ -
SUB TOTAL:				\$	75.00
SALES TAX:				\$	-
OVERHEAD:				\$	-
PROFIT: 10%				\$	7.50
TOTAL MATERIAL:				\$	62.50

TOOL AND EQUIPMENT RENTAL:

QTY	SIZE	CODE	DESCRIPTION	RATE:	TOTAL
1	Lot		Plumbing Other Cost	\$ 200.00	\$ 200.00
1	Lot		Hydronic Other Cost	\$ -	\$ -
1	Lot		Sheetmetal Other Cost	\$ -	\$ -
1	Lot		Excavation	\$ -	\$ -
SUB TOTAL:				\$	200.00
OVERHEAD:				\$	-
PROFIT: 10%				\$	20.00
TOTAL RENTAL:				\$	220.00

BOND RATE: 0.7%

TOTAL CHANGE ORDER:

THIS WILL BECOME KNOWN AS CHANGE ORDER NO.

CONTRACTOR:

BY: _____

DATE: _____

LABOR:

TYPE	CODE	RATE	HRS	TOTAL
REGULAR HOURS				
PIPE FITTER		\$ 31.00		-
PLUMBER		\$ 31.00		-
SHEET METAL FIELD		\$ 30.00	2	60.00
SHEET METAL SHOP		\$ 30.00		-
FOREMENS RATE		\$ 6.00	1	6.00
TRUCKING LABOR		\$ 25.00	0.2	5.00
OVERTIME (TIME & 1/2)				
PIPE FITTER		\$ 46.62		-
PLUMBER		\$ 46.62		-
SHEET METAL FIELD		\$ 45.00		-
SHEET METAL SHOP		\$ 45.00		-
FOREMENS RATE		\$ 9.32		-
TRUCKING LABOR		\$ 37.50		-
FRINGE BENEFITS				
PIPE FITTER		\$13.22		-
PLUMBER		\$13.22		-
SHEET METAL FIELD		\$14.28	2	28.56
SHEET METAL SHOP		\$14.28		-
LABOR BURDEN				
TOTAL				13.18
TRAVEL PAY		\$65 PER DAY		
COST PER HOUR		\$8.13		
INDIRECT COST ALLOCATION (6%)				
TOTAL				5.05
SUB TOTAL:				\$ 117.79
OVERHEAD:				\$ -
PROFIT: 10%				\$ 11.78
TOTAL LABOR:				\$ 129.57

SUBCONTRACTS:

DESCRIPTION:	CODE	TOTAL:
Insulation		\$ -
Excavation		\$ -
Test & Balance		\$ -
SUB TOTAL:		\$ -
OVERHEAD:		\$ -
PROFIT: 5%		\$ -
TOTAL SUB-CONTRACTS:		\$ -

\$ 3.02

\$ 435.09

28

SUBCONTRACTOR:
 UNITED MECHANICAL, INC.

BY: _____

DATE: July 31, 2013

MEMO

To: Sean McDaniel, Superintendent *SM 8/30/13*
From: Jeff Woodard, Director of Bonds/Construction
Date: August 30, 2013
Re: County Line Elementary Change Order #1

Respectfully request that the Board discuss, consider, and/or act upon approval of the following change order from Timberlake Construction for the County Line Elementary:

- *PC#001- Relocate AT&T telephone line - \$7,347.00
- *PC#002- Credit for using PVC in lieu of cast iron plumbing per RFI#10 – CREDIT <21,330.00>.
- *PC#003- Credit for masonry – CREDIT <\$2,000.00>.
- *PC#004- Changes per ASI#003 issued in response to City of Oklahoma City Building Code - \$14,722.00
- *PC#005- Provide 20oz Armour Matt XX mesh at all EIFS panels - \$20,098.00

This will be a net DECREASE to the contingency of **\$18,837.00**

*RW
8/30/13*



AIA Document G701™ – 2001

Change Order

PROJECT (Name and address): County Line Elementary 9201 SW 59th Street Mustang, OK 73064	CHANGE ORDER NUMBER: 001 DATE: 8-28-13	OWNER: <input checked="" type="checkbox"/> ARCHITECT: <input checked="" type="checkbox"/> CONTRACTOR: <input checked="" type="checkbox"/> FIELD: <input type="checkbox"/> OTHER: <input type="checkbox"/>
TO CONTRACTOR (Name and address): Timberlake Construction Co., Inc. PO Box 18297 Oklahoma City, OK 74154	ARCHITECT'S PROJECT NUMBER: CONTRACT DATE: 4-26-12 CONTRACT FOR: General Construction	

THE CONTRACT IS CHANGED AS FOLLOWS:

(Include, where applicable, any undisputed amount attributable to previously executed Construction Change Directives)
This change order will be a net deduct to the Owner contingency in the amount of \$18,837.00 as follows:

1. PC #001 - Relocate AT&T telephone line - \$7,347.00.
2. PC #002 - Credit for using PVC in lieu of cast iron plumbing per RFI #10 - \$<21,330.00>.
3. PC #003 - Credit for masonry - \$<2,000.00>.
4. PC #004 - Changes per ASI #003 issued in response to City of Oklahoma City Building Code - \$14,722.00.
5. PC #005 - Provide 20 oz Armour Matt XX mesh at all EIFS panels - \$20,098.00.

The original Contract Sum was	\$	13,357,361.32
The net change by previously authorized Change Orders	\$	0.00
The Contract Sum prior to this Change Order was	\$	13,357,361.32
The Contract Sum will be unchanged by this Change Order in the amount of	\$	0.00
The new Contract Sum including this Change Order will be	\$	13,357,361.32

The Contract Time will be unchanged by Zero (0) days.
The date of Substantial Completion as of the date of this Change Order therefore is August 1, 2014.

NOTE: This Change Order does not include changes in the Contract Sum, Contract Time or Guaranteed Maximum Price which have been authorized by Construction Change Directive until the cost and time have been agreed upon by both the Owner and Contractor, in which case a Change Order is executed to supersede the Construction Change Directive.

NOT VALID UNTIL SIGNED BY THE ARCHITECT, CONTRACTOR AND OWNER.

LWPB Architects ARCHITECT (Firm name) 5909 NW Expressway, Suite 600, Oklahoma City, OK 731232 ADDRESS BY (Signature) Steven Sprague (Typed name) 8/28/13 DATE	Timberlake Construction Co., Inc. CONTRACTOR (Firm name) PO Box 18297 Oklahoma City, OK 73154 ADDRESS BY (Signature) Robert Renshaw, Jr. (Typed name) 8-28-13 DATE	Mustang Public Schools OWNER (Firm name) 906 S Heights Drive, Mustang, OK 73064 ADDRESS BY (Signature) Sean McDaniel (Typed name) DATE
--	---	---

TIMBERLAKE CONSTRUCTION COMPANY, INC.

TCI JOB # 1325
County Line Elementary
PROPOSED CHANGE SUMMARY

DATE: 8/23/2013

PROPOSED CHANGE # 001

CHANGE DESCRIPTION: Cost to relocate the AT&T telephone line that currently runs approximately 2 feet below existing grade across the entire south side of the property. Work to be completed shall include but is not limited to exposing the existing 25 pair buried cable, dig and install splice pits on east and west end of property, place new cable from splice pit to 1st OG&E pole west of County Line Rd, place cable up pole and attach to 7 additional poles going west and then reactivating the cable. THE COST OF THIS WORK WILL BE DEDUCTED FROM THE PROJECT CONTINGENCY.

ADDITIONAL TIME REQUESTED DUE TO THIS CHANGE:

#	ITEM CODE	DESCRIPTION	MATERIAL	LABOR	SUB	EQUIPMENT	TOTALS
1		AT&T CWOT Group			\$6,879.76		\$6,879.76
2							\$0.00
3							\$0.00
4							\$0.00
5							\$0.00
6							\$0.00
7							\$0.00
8							\$0.00
9							\$0.00
10							\$0.00
11							\$0.00
12							\$0.00
13							\$0.00
14							\$0.00
15							\$0.00
CATEGORY TOTALS			\$0.00	\$0.00	\$6,879.76	\$0.00	\$6,879.76
0.0000%	SALES TAX		\$0.00	N/A	N/A	\$0.00	\$0.00
38.4400%	LABOR BURDEN		N/A	\$0.00	N/A	N/A	\$0.00
0.8800%	SUB BONDS		N/A	N/A	\$60.54	N/A	\$60.54
SUBTOTALS			\$0.00	\$0.00	\$6,940.30	\$0.00	\$6,940.30
					0.2400% SUB LIABILITY		\$16.66
					0.8300% BONDS		\$57.60
					4.0000% OH&P		\$277.61
					0.3200% Safety		\$22.21
					0.2200% Shop Dray		\$15.27
					0.2500% Cleanup		\$17.35
TOTAL CHANGE ORDER							\$7,347

SPECIAL NOTES AND COMMENTS ABOUT THIS CHANGE:

Special notes and comments about this change: NONE

Additional time requested due to this change: 0 Days

The work described above represents a change in scope and price and will adjust the time to the original contract as indicated. Timberlake Construction is directed to proceed with this work ASAP and the contract sum will be adjusted by change order within 15 day, or as agreed by the owner/contractor.

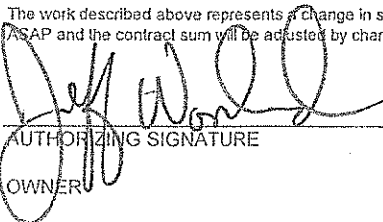
 8-27-13

AUTHORIZING SIGNATURE
OWNER

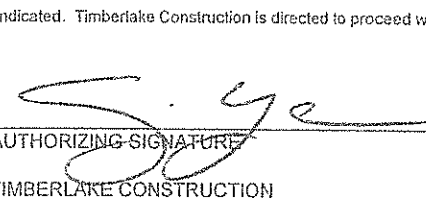

AUTHORIZING SIGNATURE
TIMBERLAKE CONSTRUCTION



APPLICATION and LETTER OF AGREEMENT FOR CUSTOM WORK

August 27, 2013

CWOTS Number:

206-13

Customer Billing Telephone Number:

N/A

BILL TO: Timberlake Construction

WORK SITE LOCATION: SW 59th & County Line Rd, Wheatland OK

DESCRIPTION OF CUSTOM WORK:

AT&T cost estimate will expose existing 25-pair buried cable, dig splice pit, place new cable from splice pit to 1st OG&E pole west of County Line Rd, place cable up pole and attach to 7 additional poles going west, activate new cable

ESTIMATED LABOR: \$4,805.00; ESTIMATED MATERIALS: \$1,535.00; ESTIMATED OVERHEAD EXPENSE: \$539.76;

TARIFF/LICENSE AGREEMENT EXPENSE: \$0.00

COST OF MONEY EXPENSE: \$0.00

CHARGE FOR CUSTOM WORK:

ESTIMATED COST: \$6,879.76

(Actual charges may exceed this estimated cost.)

Applicant requests that Southwestern Bell Telephone Company d/b/a AT&T Oklahoma, (hereafter "SWBT") act as its agent in performing the above-described custom work on Applicant's behalf. Applicant agrees to pay the charge(s) for such work. The work is to be done on an "Actual Cost" basis, all charge(s) will be computed in accordance with Southwestern Bell Corporation's ordinary accounting practices under the Uniform System of Accounts for Class A telephone companies and will include allocated costs for labor, engineering, materials, transportation, motor vehicles, tool and supply expenses and sundry billings from sub-contractors and suppliers for work and materials related to the job. The Applicant affirms that the cost estimate furnished by the Telephone Company has been considered only as an estimate of approximate costs and that the actual costs incurred by the Telephone Company in doing the work at the particular time and location might be higher. Said estimated cost is subject to change due to any number of factors including, but not limited to, changing conditions in the field, weather delays, or changes in the scope of the work.

CHANGE ORDERS

Should concealed conditions exist, including conditions that may exist below the surface of the ground, or if conditions exist that could not have been anticipated by Southwestern Bell Telephone Company at the time of this agreement, Southwestern Bell Telephone Company, will be entitled to additional funds and/or additional time to complete the work. Southwestern Bell Telephone Company will request such additional funding and/or additional time through a request for a change order.

Should Applicant or its agents, servants, or employees order or seek changes in the scope of the work, Southwestern Bell Telephone Company is entitled to seek from Applicant, its agents, servants, or employees, additional funds as necessary to perform the work, and additional time, as necessary to complete the work. Said request for additional funds and/or additional time will be through change order.

All change orders will be in writing.

All change orders will be submitted and accepted by Applicant, its agents, servants or employees, before Southwestern Bell Telephone Company, proceeds to execute the work or, if work has been initiated on the project, continues with executing the work except in an emergency endangering life or property.



Applicant, its agents, servants or employees, are deemed to have accepted the terms of any change order by signing where indicated on the change order.

Under no circumstances will Southwestern Bell Telephone Company's request for a change order be deemed or used as evidence of delay on the project. Nor will any change order issued in this project be used to charge Southwestern Bell Telephone Company with responsibility for any alleged delay on the project.

NO DAMAGE FOR DELAY

Under no circumstances will Southwestern Bell Telephone Company be held liable to Applicant, Applicant's agents, employees or contractors, for any alleged delay on the project that forms the basis for this custom work order.

TIME TO COMPLETE

Any representation by Southwestern Bell Telephone Company, its agents, servants or employees that the project, or any additional work authorized by change order, will be complete by a certain date or certain time period is strictly an estimate and not binding on Southwestern Bell Telephone Company, its agents, servants, or employees. All estimated completion dates are subject to changing conditions in the field, changes in the scope of the work, relocation of existing utilities not within Southwestern Bell Telephone Company's control, Acts of God, weather delays, labor disputes, vendor/contractor disputes, and other conditions or circumstances that Southwestern Bell Telephone Company, its agents, servants, or employees, could not reasonably anticipate at the time of the estimate.

PAYMENT

Applicant agrees to make an advance payment of \$6,879.76 prior to commencement of the work. Applicable charges for Custom Work will be billed on a special bill separate from the bill that Applicant receives for telephone service.

Applicant, its agents, servants, or employees agree to make payment on change orders within thirty (30) days of the date of signature on the change order. Failure to make payment within the designated thirty (30) day time period will operate to cancel the change order and Southwestern Bell Telephone Company, will cease all work activity on the project until payment is made.

When the Parties agree to Interval Billing *, the balance of the Contract Price or Actual Cost (as applicable) will be made in monthly payments. If the Actual Cost made varies from the Estimated Cost, then a correcting adjustment will be made in the last payment. If the parties cannot agree to Interval Billing, Applicant will make an advanced payment as indicated above.

* Applicable to orders over \$25,000 and work will take 6 or more months to complete.

CANCELLATION

If the Applicant cancels the work prior to completion, Applicant must notify Southwestern Bell Telephone Company, in writing of said cancellation.

If Applicant elects to cancel the work prior to completion, Applicant agrees to pay Southwestern Bell Telephone Company for the costs it has incurred in starting performance under the contract. If Applicant has made an advance payment, Southwestern Bell Telephone Company will deduct its costs and expenses incurred as of the date of Applicant's notice of cancellation from the amount of the advance payment. Any amount remaining will be refunded to Applicant.



ESTIMATED PRICE QUOTE

The above estimated price is guaranteed for 60 days from **August 27, 2013**. If the charges are not accepted within 60 days the order will be cancelled and a new order will need to be placed. The second estimate may be higher than the estimated price set out above.

STOP WORK ORDER

In the event that Applicant issues a stop work order, or places the project "on hold", at any point during the progress of the work, said stop work order or request to "hold" work must be issued in writing and must be delivered via certified mail, return receipt requested to **Pam Johnson, 11930 Airline Dr., Rm. 205, Houston, TX 77037**. If Applicant issues a stop work order, or a request to "hold" work, the contract price quoted herein will remain valid until sixty (60) days from the date of the stop work or "hold" work order. At the expiration of the sixty (60) days, the contract price quoted herein will expire and a new contract price will be determined and provided, in writing, to Applicant. The new contract price may be higher than the contract price quoted in this custom work order.

If, after issuing a stop work, or "hold" work order, Applicant elects to cancel the contract, Applicant must inform Southwestern Bell Telephone Company, in writing of the cancellation. Southwestern Bell Telephone Company, will deduct any expenses incurred in performing the work from Applicant's advance payment and refund any remaining funds to Applicant.

Under no circumstances will Southwestern Bell Telephone Company, be responsible to Applicant for any alleged damages or additional expenses incurred by Applicant as a result of a stop work order or an order to "hold" work on the project.

CHOICE OF LAW

Should any dispute arise between the parties concerning the subject matter of this agreement, or any term contained therein, the parties agree that the dispute or claim shall be submitted to a court of competent jurisdiction. The parties further agree that the prevailing party in any such dispute will be entitled to recover attorney's fees and costs.

Oklahoma law governs the application of this agreement and all terms contained therein.

INDEMNIFICATION AND HOLD HARMLESS

Applicant, its agents, servants, and employees hereby agree to indemnify and hold harmless Southwestern Bell Telephone Company, and its employees, agents and contractors, from and against any and all claims, costs, expenses, judgments or actions for damage to property or injury or death to persons, and/or arising from or relating to the work that is the subject of this agreement, to the extent any such claims are caused by the negligent acts or omissions of the Applicant, its agents, servants, or employees.



ENTIRE AGREEMENT

The parties agree that the terms set forth herein constitute the entire agreement and there are no other agreements regarding the project that is the subject of this agreement between the parties.

MODIFICATION & NOTICE

Any modification to this agreement must be made in writing and signed by both parties.

Any party to this agreement may provide the other party with notice of any fact or condition by providing such information in writing and serving said writing via certified mail, return receipt requested.

CWOTS Record # 206-13
ACCEPTED FOR TIMBERLAKE CONSTRUCTION:



Authorized Signature

Title: PROJECT MGR.

Company: TIMBERLAKE CONST.

Printed Name: CRAG YARDON

Date: 8/26/13

ACCEPTED FOR SOUTHWESTERN BELL TELEPHONE COMPANY:



Authorized Signature

Title: Manager OSP Planning & Engineering Design

Company: Southwestern Bell Telephone Company

Printed Name: Paul DeSpain

Date: 8/27/13



CWOTS # 206-13
SWBT Company
5305 East 71st
Tulsa, OK 74136

August 27, 2013

Craig Yadon
c/o Timberlake Construction
PO Box 18297
Oklahoma City OK 73154

Dear Mr. Yadon:

This letter is in regards to your request for Southwestern Bell Telephone Company d/b/a AT&T Oklahoma (hereafter "SWBT") to perform custom work for you. Enclosed please find an Application and Letter of Agency for Custom Work. This application describes the custom work you have requested along with the associated charges for us to do the work. We require an advance payment on this amount, which is shown on the application.

Both the signed application and the advanced payment must be received by our office before we can proceed on your behalf. Our mailing address for these documents is listed below:

AT&T
Attn: CWOT Group
5305 East 71st St
Tulsa, OK 74136-6269

Please send checks or money order made payable to AT&T.

If you decide not to proceed with this work or if you have any questions regarding this matter, please contact me directly on 918 576-2318. Please refer to the **CWOT # 206-13** when calling. You may also contact our office by calling toll free, 877-957-7775.

Sincerely,

A handwritten signature in cursive script that reads "Gail Moon".

Gail Moon
Construction & Engineering
Southwestern Bell Telephone Company



Phone: (918) 576-2318
 Fax: (918) 495-2249
 E-mail: pp0391@att.com

Invoice

Invoice #: 206-13
 Date: August 27, 2013

Bill To: Timberlake Construction
 PO Box 18297
 Oklahoma City OK 73154

Mail To: AT&T
 Attn: CWOT Group
 5305 E 71st St
 Tulsa OK 74136-6269

Date	Invoice #	Description	Amount	Payment	Balance
8/27/2013	206-13	Relocate cable at SW corner of SW 59th & County Line Rd	\$ 6,879.76	\$ -	\$ 6,879.76
				Total	\$ 6,879.76

Reminder: Please include the invoice number on your check or money order.

REMITTANCE	
Customer Name:	Timberlake Construction
Invoice #:	206-13
Date:	August 27, 2013
Amount Due:	\$6,879.76

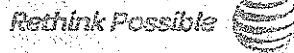

TIMBERLAKE CONSTRUCTION COMPANY, INC.

TCI JOB # 1325
County Line Elementary
PROPOSED CHANGE SUMMARY

DATE: 8/26/2013

PROPOSED CHANGE # 002

CHANGE DESCRIPTION: Credit for using PVC in lieu of cast iron plumbing above grade and below grade per RFI #10.

ADDITIONAL TIME REQUESTED DUE TO THIS CHANGE:

#	ITEM CODE	DESCRIPTION	MATERIAL	LABOR	SUB	EQUIPMENT	TOTALS
1		Orcuit Mechanical Contractors			(\$21,330.00)		(\$21,330.00)
2							\$0.00
3							\$0.00
4							\$0.00
5							\$0.00
6							\$0.00
7							\$0.00
8							\$0.00
9							\$0.00
10							\$0.00
11							\$0.00
12							\$0.00
13							\$0.00
14							\$0.00
15							\$0.00
CATEGORY TOTALS			\$0.00	\$0.00	(\$21,330.00)	\$0.00	(\$21,330.00)
0.0000%	SALES TAX	\$0.00	N/A	N/A	N/A	\$0.00	\$0.00
38.4400%	LABOR BURDEN	\$0.00	N/A	\$0.00	N/A	N/A	\$0.00
0.8800%	SUB BONDS	N/A	N/A	N/A	\$0.00	N/A	\$0.00
SUBTOTALS			\$0.00	\$0.00	(\$21,330.00)	\$0.00	(\$21,330.00)
				0.2400%	SUB LIABILITY		\$0.00
				0.8300%	BONDS		\$0.00
				4.0000%	OH&P		\$0.00
				0.3200%	Safety		\$0.00
				0.2200%	Shop Dray		\$0.00
				0.2500%	Cleanup		\$0.00
TOTAL CHANGE ORDER							(\$21,330)

SPECIAL NOTES AND COMMENTS ABOUT THIS CHANGE:

Special notes and comments about this change: NONE

Additional time requested due to this change: 0 Days

The work described above represents a change in scope and price and will adjust the time to the original contract as indicated. Timberlake Construction is directed to proceed with this work ASAP and the contract sum will be adjusted by change order within 15 day, or as agreed by the owner/contractor.

 8-27-13

AUTHORIZING SIGNATURE
OWNER



AUTHORIZING SIGNATURE
TIMBERLAKE CONSTRUCTION



5940 NW 38th Street
Oklahoma City, Oklahoma
73122
Phone: (405) 787-5888
Fax: (405) 787-5999

August 13, 2013

Timberlake Construction, Inc.
P.O. Box 18297
Oklahoma City, Oklahoma
73154

Attention: Cale Lopp
Phone: 405-840-2521
Fax: 405-840-5469

Our RFI Number: RFI-002
Our Project Number: TCI-132
Project Name: COUNTY LINE ELEM. - 15TH

Response Due: August 20, 2013

Regarding: Plumbing

Subject: Waste and vent piping

We are requesting information on the following:

In the mechanical specs for the job it calls for cast iron piping to be used for the project. SCH 40 PVC is allowed by code in areas where there is not a return air plenum and we would request to use this material in areas allowed by code. One of the main reasons we would like to use this material is the speed of install. The ground job as well as the block walls will go much faster with PVC material than with cast iron, and the schedule will improve in these areas. We would offer a credit to the owner of \$21,233.00 for the use of PVC. Also note I have offered a voluntary deduct on ASI #3 if PVC is allowed.

Sincerely,
Matt Weber

Response:

TIMBERLAKE CONSTRUCTION COMPANY, INC.

TCI JOB # 1325
County Line Elementary
PROPOSED CHANGE SUMMARY

DATE: 8/27/2013

PROPOSED CHANGE # 003

CHANGE DESCRIPTION: Voluntary credit from ACME Brick to C&N Masonry.

ADDITIONAL TIME REQUESTED DUE TO THIS CHANGE:

#	ITEM CODE	DESCRIPTION	MATERIAL	LABOR	SUB	EQUIPMENT	TOTALS
1		C & N Masonry			(\$2,000.00)		(\$2,000.00)
2							\$0.00
3							\$0.00
4							\$0.00
5							\$0.00
6							\$0.00
7							\$0.00
8							\$0.00
9							\$0.00
10							\$0.00
11							\$0.00
12							\$0.00
13							\$0.00
14							\$0.00
15							\$0.00
CATEGORY TOTALS			\$0.00	\$0.00	(\$2,000.00)	\$0.00	(\$2,000.00)
0.0000%	SALES TAX	\$0.00	N/A	N/A	N/A	\$0.00	\$0.00
38.4400%	LABOR BURDEN	\$0.00	N/A	\$0.00	N/A	N/A	\$0.00
0.8800%	SUB BONDS	\$0.00	N/A	N/A	\$0.00	N/A	\$0.00
SUBTOTALS			\$0.00	\$0.00	(\$2,000.00)	\$0.00	(\$2,000.00)
				0.2400% SUB LIABILITY			\$0.00
				0.8300% BONDS			\$0.00
				4.0000% OH&P			\$0.00
				0.3200% Safety			\$0.00
				0.2200% Shop Dray			\$0.00
				0.2500% Cleanup			\$0.00
TOTAL CHANGE ORDER							(\$2,000)

SPECIAL NOTES AND COMMENTS ABOUT THIS CHANGE:

Special notes and comments about this change: NONE

Additional time requested due to this change: 0 Days

The work described above represents a change in scope and price and will adjust the time to the original contract as indicated. Timberlake Construction is directed to proceed with this work ASAP and the contract sum will be adjusted by change order within 15 day, or as agreed by the owner/contractor.

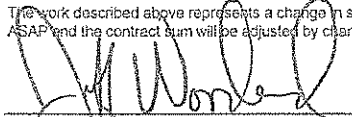
 8-27-13

AUTHORIZING SIGNATURE
OWNER

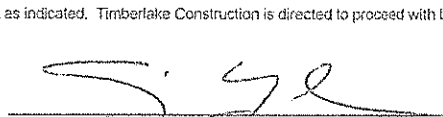

AUTHORIZING SIGNATURE
TIMBERLAKE CONSTRUCTION

TIMBERLAKE CONSTRUCTION COMPANY, INC.

TCI JOB # 1325
County Line Elementary
PROPOSED CHANGE SUMMARY

DATE: 8/27/2013

PROPOSED CHANGE # 004

CHANGE DESCRIPTION: ASI #003 - Issued as a response to The City of Oklahoma City Building Code review comments (see attached with responses). Also, change doors A161 and A164 to frame type "3" in lieu of type "1".

ADDITIONAL TIME REQUESTED DUE TO THIS CHANGE:

#	ITEM CODE	DESCRIPTION	MATERIAL	LABOR	SUB	EQUIPMENT	TOTALS
1		Orcutt Mechanical Contractors (Add 10 sinks)			\$9,423.00		\$9,423.00
2		EGR (Credit for millwork)	\$100.00		(\$3,343.00)		(\$3,243.00)
3		Timberlake Construction (Add blocking, install soap dishes)	\$100.00	\$150.00			\$250.00
4		Beniley Flooring (Additional ceramic tile)			\$5,693.00		\$5,693.00
5		Precision Door (Add 10 18" x 36" mirrors)	\$802.00	\$100.00			\$902.00
6		Scovil & Sides (Added HM sidelight)	\$541.00				\$541.00
7		Binswanger Glass (Glass @ 2 ea Sidelights)	\$220.00				\$220.00
8							\$0.00
9							\$0.00
10							\$0.00
11							\$0.00
12							\$0.00
13							\$0.00
14							\$0.00
15							\$0.00
CATEGORY TOTALS			\$1,763.00	\$250.00	\$11,773.00	\$0.00	\$13,786.00
0.0000%	SALES TAX		\$0.00	N/A	N/A	\$0.00	\$0.00
38.4400%	LABOR BURDEN		N/A	\$0.00	N/A	N/A	\$0.00
0.8800%	SUB BONDS		N/A	N/A	\$121.32	N/A	\$121.32
SUBTOTALS			\$1,763.00	\$250.00	\$11,894.32	\$0.00	\$13,907.32
					0.2400% SUB LIABILITY		\$33.38
					0.8300% BONDS		\$115.43
					4.0000% OH&P		\$556.29
					0.3200% Safety		\$44.50
					0.2200% Shop Dray		\$30.60
					0.2500% Cleanup		\$34.77
TOTAL CHANGE ORDER							\$14,722

SPECIAL NOTES AND COMMENTS ABOUT THIS CHANGE:

Special notes and comments about this change: NONE

Additional time requested due to this change: 0 Days

The work described above represents a change in scope and price and will adjust the time to the original contract as indicated. Timberlake Construction is directed to proceed with this work ASAP and the contract sum will be adjusted by change order within 15 day, or as agreed by the owner/contractor.

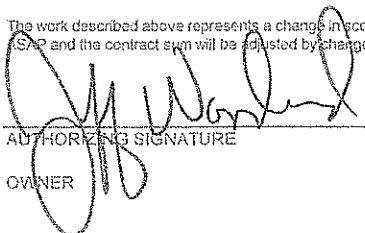
 8-27-13

AUTHORIZING SIGNATURE
OWNER



AUTHORIZING SIGNATURE
TIMBERLAKE CONSTRUCTION



The City of
OKLAHOMA CITY

Development Services
420 West Main Street - 8th floor
Oklahoma City, OK 73102

BUILDING CODE REVIEW

Date: 6/19/2013

Building Address: 9201 SW 59TH ST OKLAHOMA CITY, OK 73179

Type Construction: II.B

Use Group: E / A-2 /A-3/ B

Application #: BLDC-2013-05119

Reviewer: Randy Edwards

Sprinkler: Yes

The following items shall be complied with prior to occupancy:

Posting Structures - Occupant Load Must Be Posted. Occupancy Load: 2370

Minimum Uniformly Distributed Live Loads Must be: Live Load: 80

Structures Must Comply With Energy Conservation Requirements.

Smoke Detectors Required Code Section Ord. #16500

All Reserved Accessible Parking Spaces Shall Be Posted With Above Grade Sign Code Section Ord. #18743

This Review Covers Building Code Compliance Only: All Other Work, i.e., Mechanical, Electrical, Plumbing, etc., Shall Comply With Their Respective Codes.

The Owner Must Independently Achieve Compliance With The Americans With Disabilities Act.

Safety Glazing As Required Code Section 2406.0

- 1) Emergency egress lighting & illuminated exit signs req'd per Section 1011 including Tactile Exit Signs at req'd doors.
- 2) Panic hardware required on exits. We will comply We will comply
- 3) Fire alarm system required- NFPA 72. We will comply
- 4) Fire suppression system required/separate permit- NFPA 13. We will comply
- 5) Special Inspections required- See attached letter from METCO. Russelville Steel is providing steel and is AISC
- 6) Building oversized for IIB type of construction for A-3/E use - max allowed 45,125 sq ft / actual 79665 sq ft. Approved
- 7) Fire walls per plans(A6.9 & Eng. Cert) - Building oversized for A-3/E use - max allowed - Board Of Appeals filed. Approved
- 8) 5 wheel chair spaces required for bleacher seating per Table 1108.2.2.1. We shall comply. Bleacher Shop drawings will be submitted by the Construction Manager.
- 9) Restroom (s) to comply with ICC/ANSI Standard:
60" clear required at WC wall to sink/cabinet edge.
60" turning space. Design complies with this.
- 10) Single user restrooms require lavatories in the same room (IPC 2000 section 405.3.3). Pending
- 11) 60" required for front approach to door at single user restrooms at pre-k and K rooms. Design complies with this.
- 12) 60" turning required in Girls restrooms - B114, B120, D105. See revised layout for compliance.
- 13) Maximum 34" height req'd for accessible sink(s) / including breakroom areas. Design complies with this.
- 14) Provide details on sinks in core restrooms - accessibility. See attached cut sheet for Bradley Terreon Washfountain
- 15) Ramp to have Max 1:12 slope - provide details. Design complies with this. See revised sheet A2.6 for dimensions
- 16) Provide plans for bleachers including handrail & guardrail details. Bleacher Shop drawings will be submitted by the CM.
- 17) Accessible service counter req'd- Max. 36" high/ Min 36" wide / careteria. Design complies with this. See attached 8 1/2" x 11" for clarification.

All work shall comply with all local ordinances and codes, including all applicable sections of the International Building Code as adopted by The City of Oklahoma City.

An approved set of building plans, along with the review worksheet(s), must be on the site of the project at all times.

I hereby agree to comply with all the requirements mentioned above.

Printed Name: _____ Signature: _____

323

TO BE SIGNED AT TIME OF PERMIT ISSUANCE ONLY

 **Document G710™ – 1992**

Architect's Supplemental Instructions

PROJECT (Name and address):
County Line Elementary School

**ARCHITECT'S SUPPLEMENTAL
INSTRUCTION NO:** 003

OWNER:

ARCHITECT:

CONSULTANT:

CONTRACTOR:

FIELD:

OTHER:

OWNER (Name and address):
Mustang Public Schools, ISD 69
906 South Heights Drive
Mustang, OK 73064-3542

DATE OF ISSUANCE: July 31, 2013

CONTRACT FOR: General Construction

**FROM ARCHITECT (Name and
address):**
LWPB, P.C.
5909 NW Expressway, Suite 600
Oklahoma City, Oklahoma 73132

CONTRACT DATE:

**TO CONTRACTOR (Name and
address):**
Timberlake Construction
7613 North Classen
Oklahoma City, OK 73116

ARCHITECT'S PROJECT NUMBER:
12-1245-E823

The Work shall be carried out in accordance with the following supplemental instructions issued in accordance with the Contract Documents without change in Contract Sum or Contract Time. Proceeding with the Work in accordance with these instructions indicates your acknowledgment that there will be no change in the Contract Sum or Contract Time.

DESCRIPTION:

Change doors A151 & A154 to a frame type "3" with a sidelight in lieu of type "1". All other changes have been bubbled on the attached revised 30"x42" drawings.

ATTACHMENTS:

(Here insert listing of documents that support description.)

L1, A2.1, A2.2, A2.3, A2.4, A2.5, A2.6, A2.16, A3.1, A3.2, A7.1, A7.2, M0.1, M4.1, M4.2, M4.3, M4.4, M4.5, M4.6, M4.7, M4.8, M5.0, & M5.1

ISSUED BY THE ARCHITECT:

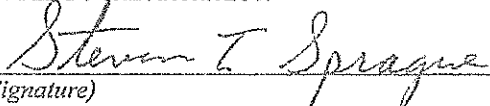
(Signature)

Steve Sprague, AIA
(Printed name and title)

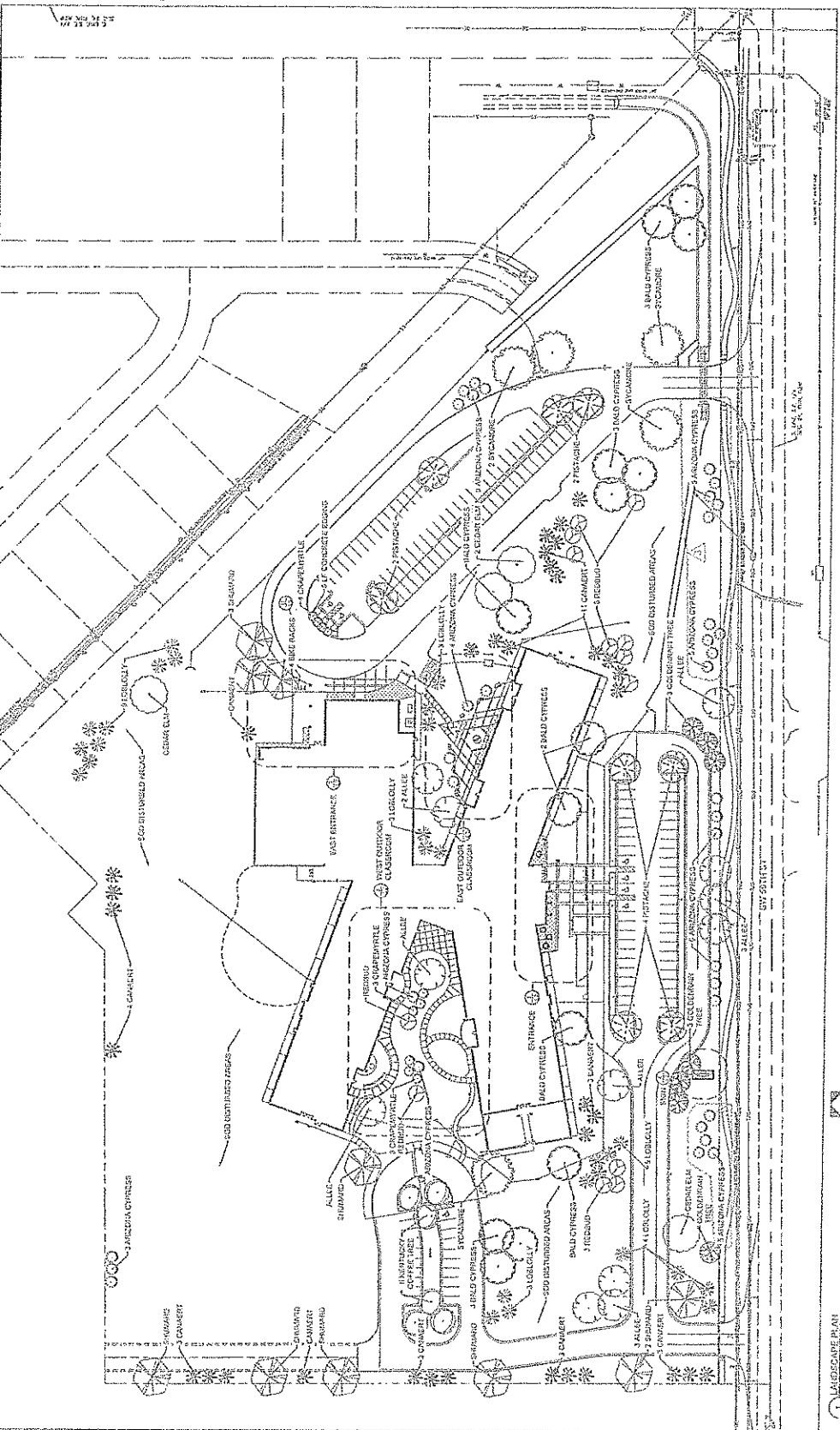
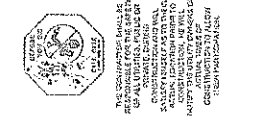

NOTE: LANDSCAPING AND IRRIGATION SHALL BE PROVIDED BY THE OWNER.

PLANTING	QUANTITY	PLANTING DATE	PLANTING METHOD	PLANTING NOTES
1. CAMELOT	10	10/2017	PLANT	PLANT IN 18" DIA. HOLES
2. STENOCHLOA	10	10/2017	PLANT	PLANT IN 18" DIA. HOLES
3. BIRD CHERRY	10	10/2017	PLANT	PLANT IN 18" DIA. HOLES
4. SWEET GUM	10	10/2017	PLANT	PLANT IN 18" DIA. HOLES
5. RED TWIG DOGWOOD	10	10/2017	PLANT	PLANT IN 18" DIA. HOLES
6. LILAC	10	10/2017	PLANT	PLANT IN 18" DIA. HOLES
7. YUCCA	10	10/2017	PLANT	PLANT IN 18" DIA. HOLES
8. SPANISH BROOM	10	10/2017	PLANT	PLANT IN 18" DIA. HOLES
9. CACTUS	10	10/2017	PLANT	PLANT IN 18" DIA. HOLES
10. AGAVE	10	10/2017	PLANT	PLANT IN 18" DIA. HOLES
11. SAGE PALM	10	10/2017	PLANT	PLANT IN 18" DIA. HOLES
12. PALM	10	10/2017	PLANT	PLANT IN 18" DIA. HOLES
13. OLIVE	10	10/2017	PLANT	PLANT IN 18" DIA. HOLES
14. JASMINE	10	10/2017	PLANT	PLANT IN 18" DIA. HOLES
15. HYDRANGEA	10	10/2017	PLANT	PLANT IN 18" DIA. HOLES
16. RHODODENDRON	10	10/2017	PLANT	PLANT IN 18" DIA. HOLES
17. AZALEA	10	10/2017	PLANT	PLANT IN 18" DIA. HOLES
18. GARDEN SPIDER LILY	10	10/2017	PLANT	PLANT IN 18" DIA. HOLES
19. TULIP	10	10/2017	PLANT	PLANT IN 18" DIA. HOLES
20. DAFODIL	10	10/2017	PLANT	PLANT IN 18" DIA. HOLES
21. IRIS	10	10/2017	PLANT	PLANT IN 18" DIA. HOLES
22. HYDRANGEA	10	10/2017	PLANT	PLANT IN 18" DIA. HOLES
23. RHODODENDRON	10	10/2017	PLANT	PLANT IN 18" DIA. HOLES
24. AZALEA	10	10/2017	PLANT	PLANT IN 18" DIA. HOLES
25. GARDEN SPIDER LILY	10	10/2017	PLANT	PLANT IN 18" DIA. HOLES
26. TULIP	10	10/2017	PLANT	PLANT IN 18" DIA. HOLES
27. DAFODIL	10	10/2017	PLANT	PLANT IN 18" DIA. HOLES
28. IRIS	10	10/2017	PLANT	PLANT IN 18" DIA. HOLES
29. HYDRANGEA	10	10/2017	PLANT	PLANT IN 18" DIA. HOLES
30. RHODODENDRON	10	10/2017	PLANT	PLANT IN 18" DIA. HOLES
31. AZALEA	10	10/2017	PLANT	PLANT IN 18" DIA. HOLES
32. GARDEN SPIDER LILY	10	10/2017	PLANT	PLANT IN 18" DIA. HOLES
33. TULIP	10	10/2017	PLANT	PLANT IN 18" DIA. HOLES
34. DAFODIL	10	10/2017	PLANT	PLANT IN 18" DIA. HOLES
35. IRIS	10	10/2017	PLANT	PLANT IN 18" DIA. HOLES
36. HYDRANGEA	10	10/2017	PLANT	PLANT IN 18" DIA. HOLES
37. RHODODENDRON	10	10/2017	PLANT	PLANT IN 18" DIA. HOLES
38. AZALEA	10	10/2017	PLANT	PLANT IN 18" DIA. HOLES
39. GARDEN SPIDER LILY	10	10/2017	PLANT	PLANT IN 18" DIA. HOLES
40. TULIP	10	10/2017	PLANT	PLANT IN 18" DIA. HOLES
41. DAFODIL	10	10/2017	PLANT	PLANT IN 18" DIA. HOLES
42. IRIS	10	10/2017	PLANT	PLANT IN 18" DIA. HOLES
43. HYDRANGEA	10	10/2017	PLANT	PLANT IN 18" DIA. HOLES
44. RHODODENDRON	10	10/2017	PLANT	PLANT IN 18" DIA. HOLES
45. AZALEA	10	10/2017	PLANT	PLANT IN 18" DIA. HOLES
46. GARDEN SPIDER LILY	10	10/2017	PLANT	PLANT IN 18" DIA. HOLES
47. TULIP	10	10/2017	PLANT	PLANT IN 18" DIA. HOLES
48. DAFODIL	10	10/2017	PLANT	PLANT IN 18" DIA. HOLES
49. IRIS	10	10/2017	PLANT	PLANT IN 18" DIA. HOLES
50. HYDRANGEA	10	10/2017	PLANT	PLANT IN 18" DIA. HOLES
51. RHODODENDRON	10	10/2017	PLANT	PLANT IN 18" DIA. HOLES
52. AZALEA	10	10/2017	PLANT	PLANT IN 18" DIA. HOLES
53. GARDEN SPIDER LILY	10	10/2017	PLANT	PLANT IN 18" DIA. HOLES
54. TULIP	10	10/2017	PLANT	PLANT IN 18" DIA. HOLES
55. DAFODIL	10	10/2017	PLANT	PLANT IN 18" DIA. HOLES
56. IRIS	10	10/2017	PLANT	PLANT IN 18" DIA. HOLES
57. HYDRANGEA	10	10/2017	PLANT	PLANT IN 18" DIA. HOLES
58. RHODODENDRON	10	10/2017	PLANT	PLANT IN 18" DIA. HOLES
59. AZALEA	10	10/2017	PLANT	PLANT IN 18" DIA. HOLES
60. GARDEN SPIDER LILY	10	10/2017	PLANT	PLANT IN 18" DIA. HOLES
61. TULIP	10	10/2017	PLANT	PLANT IN 18" DIA. HOLES
62. DAFODIL	10	10/2017	PLANT	PLANT IN 18" DIA. HOLES
63. IRIS	10	10/2017	PLANT	PLANT IN 18" DIA. HOLES
64. HYDRANGEA	10	10/2017	PLANT	PLANT IN 18" DIA. HOLES
65. RHODODENDRON	10	10/2017	PLANT	PLANT IN 18" DIA. HOLES
66. AZALEA	10	10/2017	PLANT	PLANT IN 18" DIA. HOLES
67. GARDEN SPIDER LILY	10	10/2017	PLANT	PLANT IN 18" DIA. HOLES
68. TULIP	10	10/2017	PLANT	PLANT IN 18" DIA. HOLES
69. DAFODIL	10	10/2017	PLANT	PLANT IN 18" DIA. HOLES
70. IRIS	10	10/2017	PLANT	PLANT IN 18" DIA. HOLES
71. HYDRANGEA	10	10/2017	PLANT	PLANT IN 18" DIA. HOLES
72. RHODODENDRON	10	10/2017	PLANT	PLANT IN 18" DIA. HOLES
73. AZALEA	10	10/2017	PLANT	PLANT IN 18" DIA. HOLES
74. GARDEN SPIDER LILY	10	10/2017	PLANT	PLANT IN 18" DIA. HOLES
75. TULIP	10	10/2017	PLANT	PLANT IN 18" DIA. HOLES
76. DAFODIL	10	10/2017	PLANT	PLANT IN 18" DIA. HOLES
77. IRIS	10	10/2017	PLANT	PLANT IN 18" DIA. HOLES
78. HYDRANGEA	10	10/2017	PLANT	PLANT IN 18" DIA. HOLES
79. RHODODENDRON	10	10/2017	PLANT	PLANT IN 18" DIA. HOLES
80. AZALEA	10	10/2017	PLANT	PLANT IN 18" DIA. HOLES
81. GARDEN SPIDER LILY	10	10/2017	PLANT	PLANT IN 18" DIA. HOLES
82. TULIP	10	10/2017	PLANT	PLANT IN 18" DIA. HOLES
83. DAFODIL	10	10/2017	PLANT	PLANT IN 18" DIA. HOLES
84. IRIS	10	10/2017	PLANT	PLANT IN 18" DIA. HOLES
85. HYDRANGEA	10	10/2017	PLANT	PLANT IN 18" DIA. HOLES
86. RHODODENDRON	10	10/2017	PLANT	PLANT IN 18" DIA. HOLES
87. AZALEA	10	10/2017	PLANT	PLANT IN 18" DIA. HOLES
88. GARDEN SPIDER LILY	10	10/2017	PLANT	PLANT IN 18" DIA. HOLES
89. TULIP	10	10/2017	PLANT	PLANT IN 18" DIA. HOLES
90. DAFODIL	10	10/2017	PLANT	PLANT IN 18" DIA. HOLES
91. IRIS	10	10/2017	PLANT	PLANT IN 18" DIA. HOLES
92. HYDRANGEA	10	10/2017	PLANT	PLANT IN 18" DIA. HOLES
93. RHODODENDRON	10	10/2017	PLANT	PLANT IN 18" DIA. HOLES
94. AZALEA	10	10/2017	PLANT	PLANT IN 18" DIA. HOLES
95. GARDEN SPIDER LILY	10	10/2017	PLANT	PLANT IN 18" DIA. HOLES
96. TULIP	10	10/2017	PLANT	PLANT IN 18" DIA. HOLES
97. DAFODIL	10	10/2017	PLANT	PLANT IN 18" DIA. HOLES
98. IRIS	10	10/2017	PLANT	PLANT IN 18" DIA. HOLES
99. HYDRANGEA	10	10/2017	PLANT	PLANT IN 18" DIA. HOLES
100. RHODODENDRON	10	10/2017	PLANT	PLANT IN 18" DIA. HOLES
101. AZALEA	10	10/2017	PLANT	PLANT IN 18" DIA. HOLES
102. GARDEN SPIDER LILY	10	10/2017	PLANT	PLANT IN 18" DIA. HOLES
103. TULIP	10	10/2017	PLANT	PLANT IN 18" DIA. HOLES
104. DAFODIL	10	10/2017		



Mustang Public Schools
 COUNTY LINE ELEMENTARY
 Oklahoma City, OK

DATE: 01/14/2014
 SCALE: 1/8" = 1'-0"
 PROJECT NO: 14-0000000000

COMPOSITE FLOOR PLAN
 A2.1

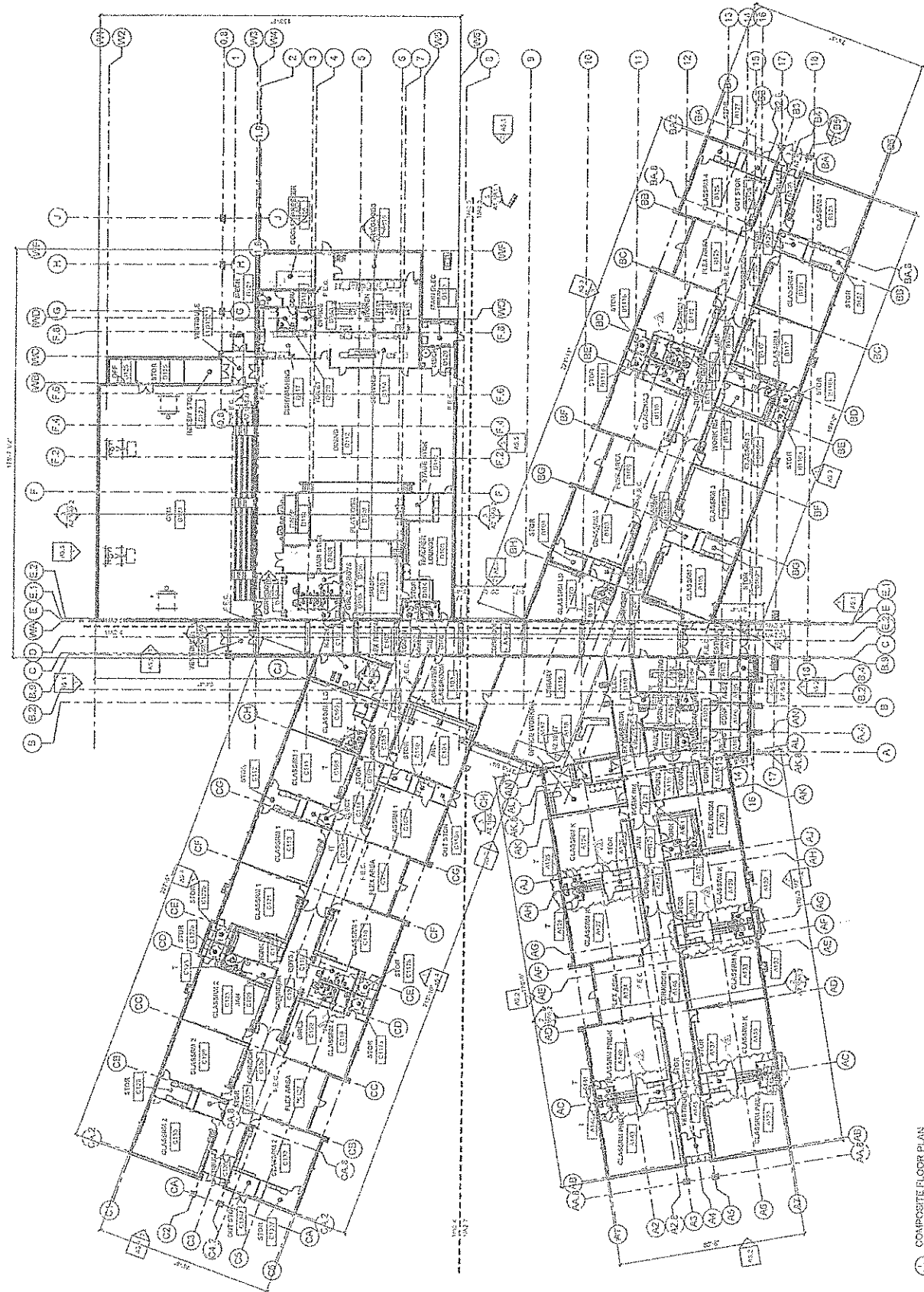
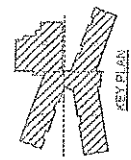

COMPOSITE FLOOR PLAN
 COUNTY LINE ELEMENTARY





OKLAHOMA STATE UNIVERSITY
SCHOOL OF ARCHITECTURE
FACULTY ARCHITECTS



COUNTY LINE ELEMENTARY

Mustang Public Schools

Okahoma City, OK

SCALE: 1/8" = 1'-0"
DATE: 10/15/11
PROJECT: COUNTY LINE ELEMENTARY

DESIGNED BY: [Name]
CHECKED BY: [Name]

NO. A2.2
PROJECT: COUNTY LINE ELEMENTARY

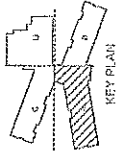
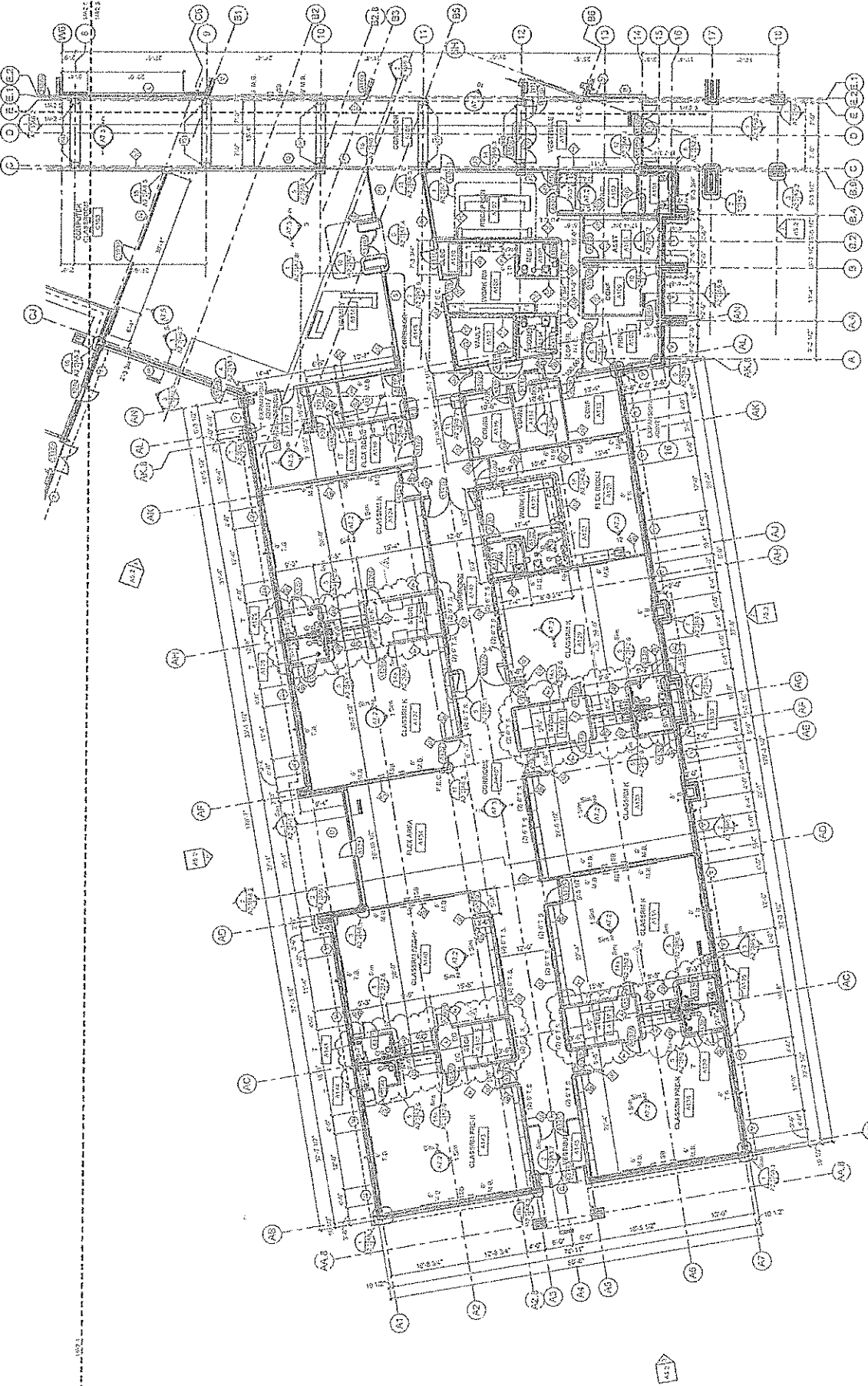

- REVISIONS:**
- 1. MARKED STALL DOOR ACCESS LAYOUT
 - 2. PROVIDE 3/4" FIRE TREATED PLYWOOD FINISHING ON ALL WALLS IN THE ROOM
 - 3. VERTICAL CURTAINS (SHOWN) TO BE FINISHED ABOUT ON BOTH SIDES OF WALL
 - 4. CURTAIN ELEMENT FINISHED UNDER THE FINISH FLOOR FINISH IS SHOWN ON UNIT 1
 - 5. PROVIDE 1/2" GYPSON BOARD WALL FOR FINISHING THE SIDEWALLS IN FRONT OF BRICKWORK, BRACKING
 - 6. 8" TYPICAL WALL WITH 1/4" FINISH STEEL TUBE REINFORCING AND SOLID BRICK CORE MATERIAL, GYPSON BOARD WALL FINISHING FINISHABLE, DOOR AT 30' x 7' 6", AND ONE AT 12' x 6' 6".
 - 7. 3/4" WALL FINISH WITH 1/2" GYPSON BOARD FINISH ABOUT AT 12' x 6' 6".

- REVISIONS:**
- 1. RETURN TO ACCESS POINTS AND ASSET TO ALL WALLS IN FINISHING AND NORMAL DIMENSIONS
 - 2. REFER TO GYM PLAN FOR CLEARANCE REQUIREMENTS
 - 3. ALL TO THE TOP OF 1" N.
 - 4. FINISH ACCESS POINTS FOR ALL WALLS WITH FINISHING, DIMENSIONS, DATE: 10/15/11, 12:41:40
 - 5. ALL DIMENSIONS ARE TO FACE UNLESS NOTED OTHERWISE
 - 6. FINISH ACCESS POINTS AT 12' x 6' 6" TO THE BOTTOM
 - 7. FINISH ACCESS POINTS AT 12' x 6' 6" TO THE BOTTOM
 - 8. FINISH ACCESS POINTS AT 12' x 6' 6" TO THE BOTTOM
 - 9. FINISH ACCESS POINTS AT 12' x 6' 6" TO THE BOTTOM
 - 10. FINISH ACCESS POINTS AT 12' x 6' 6" TO THE BOTTOM



Mustang Public Schools
 COUNTY LINE ELEMENTARY
 Oklahoma City, OK

DATE: 08/20/13
 SHEET: 02 OF 04
 PROJECT: COUNTY LINE ELEMENTARY

SCALE: AS SHOWN
 DRAWN BY: J. HARRIS
 CHECKED BY: J. HARRIS

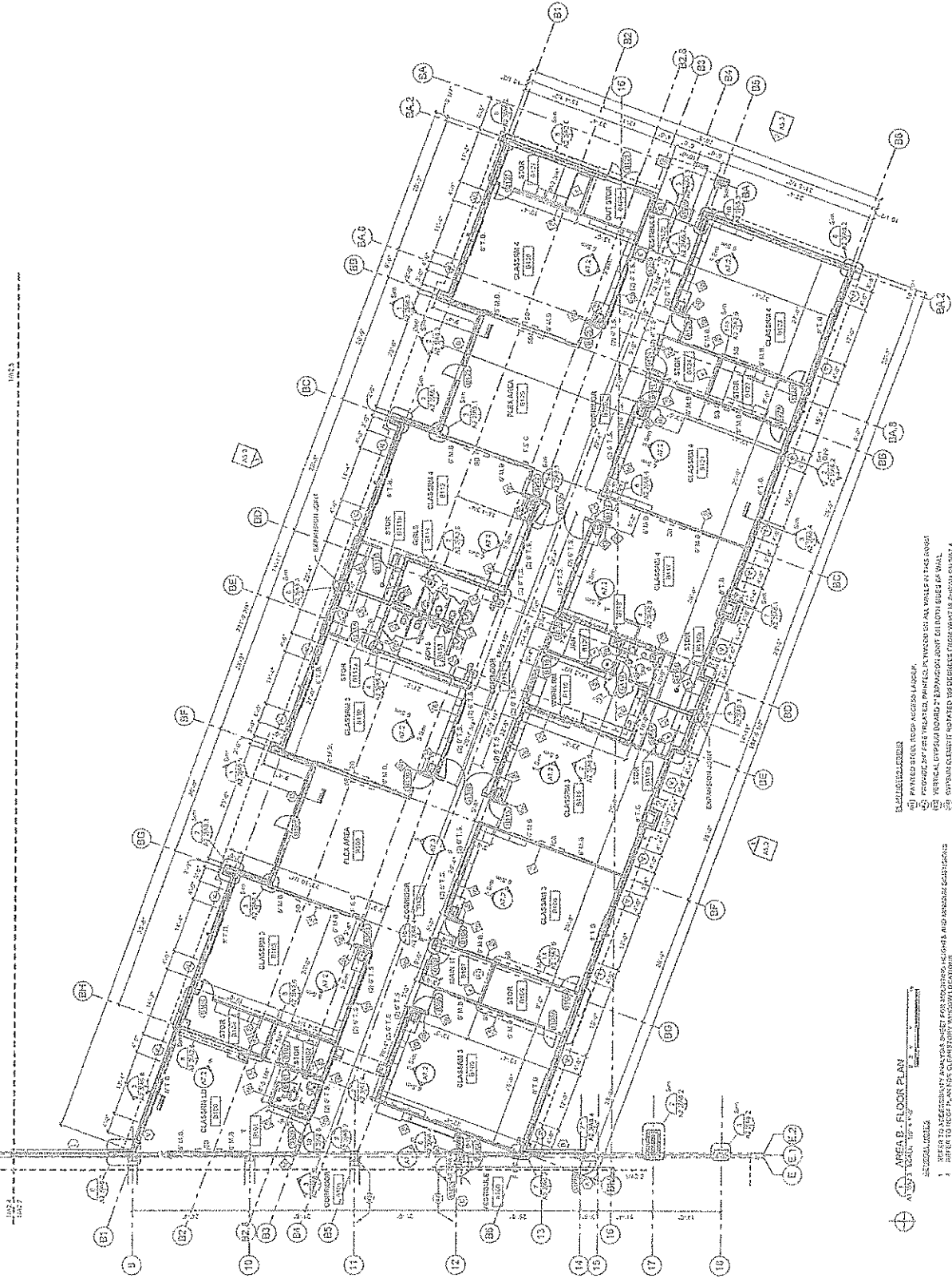
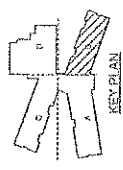

- REVISIONS:**
- 1) FINISHED FLOOR LEVELS ADJUSTED.
 - 2) FINISHED FLOOR LEVELS ADJUSTED TO MATCH EXISTING LEVELS AT ALL WALLS IN THE NORTH AND SOUTH CORNERS OF THE BUILDING.
 - 3) FINISHED FLOOR LEVELS ADJUSTED TO MATCH EXISTING LEVELS AT ALL WALLS IN THE NORTH AND SOUTH CORNERS OF THE BUILDING.
 - 4) FINISHED FLOOR LEVELS ADJUSTED TO MATCH EXISTING LEVELS AT ALL WALLS IN THE NORTH AND SOUTH CORNERS OF THE BUILDING.
 - 5) FINISHED FLOOR LEVELS ADJUSTED TO MATCH EXISTING LEVELS AT ALL WALLS IN THE NORTH AND SOUTH CORNERS OF THE BUILDING.
 - 6) FINISHED FLOOR LEVELS ADJUSTED TO MATCH EXISTING LEVELS AT ALL WALLS IN THE NORTH AND SOUTH CORNERS OF THE BUILDING.
 - 7) FINISHED FLOOR LEVELS ADJUSTED TO MATCH EXISTING LEVELS AT ALL WALLS IN THE NORTH AND SOUTH CORNERS OF THE BUILDING.
 - 8) FINISHED FLOOR LEVELS ADJUSTED TO MATCH EXISTING LEVELS AT ALL WALLS IN THE NORTH AND SOUTH CORNERS OF THE BUILDING.
 - 9) FINISHED FLOOR LEVELS ADJUSTED TO MATCH EXISTING LEVELS AT ALL WALLS IN THE NORTH AND SOUTH CORNERS OF THE BUILDING.
 - 10) FINISHED FLOOR LEVELS ADJUSTED TO MATCH EXISTING LEVELS AT ALL WALLS IN THE NORTH AND SOUTH CORNERS OF THE BUILDING.
 - 11) FINISHED FLOOR LEVELS ADJUSTED TO MATCH EXISTING LEVELS AT ALL WALLS IN THE NORTH AND SOUTH CORNERS OF THE BUILDING.
 - 12) FINISHED FLOOR LEVELS ADJUSTED TO MATCH EXISTING LEVELS AT ALL WALLS IN THE NORTH AND SOUTH CORNERS OF THE BUILDING.
 - 13) FINISHED FLOOR LEVELS ADJUSTED TO MATCH EXISTING LEVELS AT ALL WALLS IN THE NORTH AND SOUTH CORNERS OF THE BUILDING.
 - 14) FINISHED FLOOR LEVELS ADJUSTED TO MATCH EXISTING LEVELS AT ALL WALLS IN THE NORTH AND SOUTH CORNERS OF THE BUILDING.
 - 15) FINISHED FLOOR LEVELS ADJUSTED TO MATCH EXISTING LEVELS AT ALL WALLS IN THE NORTH AND SOUTH CORNERS OF THE BUILDING.
 - 16) FINISHED FLOOR LEVELS ADJUSTED TO MATCH EXISTING LEVELS AT ALL WALLS IN THE NORTH AND SOUTH CORNERS OF THE BUILDING.
 - 17) FINISHED FLOOR LEVELS ADJUSTED TO MATCH EXISTING LEVELS AT ALL WALLS IN THE NORTH AND SOUTH CORNERS OF THE BUILDING.

- NOTES:**
1. REFER TO SUPPLEMENTARY WORK SHEET FOR FINISHING HEIGHTS AND FINISHING CONDITIONS.
 2. ALL FINISHING HEIGHTS AND CONDITIONS SHALL BE AS SHOWN ON THIS SHEET UNLESS OTHERWISE NOTED.
 3. FINISHED FLOOR LEVELS SHALL BE AS SHOWN ON THIS SHEET UNLESS OTHERWISE NOTED.
 4. FINISHED FLOOR LEVELS SHALL BE AS SHOWN ON THIS SHEET UNLESS OTHERWISE NOTED.
 5. FINISHED FLOOR LEVELS SHALL BE AS SHOWN ON THIS SHEET UNLESS OTHERWISE NOTED.
 6. FINISHED FLOOR LEVELS SHALL BE AS SHOWN ON THIS SHEET UNLESS OTHERWISE NOTED.
 7. FINISHED FLOOR LEVELS SHALL BE AS SHOWN ON THIS SHEET UNLESS OTHERWISE NOTED.
 8. FINISHED FLOOR LEVELS SHALL BE AS SHOWN ON THIS SHEET UNLESS OTHERWISE NOTED.
 9. FINISHED FLOOR LEVELS SHALL BE AS SHOWN ON THIS SHEET UNLESS OTHERWISE NOTED.
 10. FINISHED FLOOR LEVELS SHALL BE AS SHOWN ON THIS SHEET UNLESS OTHERWISE NOTED.
 11. FINISHED FLOOR LEVELS SHALL BE AS SHOWN ON THIS SHEET UNLESS OTHERWISE NOTED.
 12. FINISHED FLOOR LEVELS SHALL BE AS SHOWN ON THIS SHEET UNLESS OTHERWISE NOTED.
 13. FINISHED FLOOR LEVELS SHALL BE AS SHOWN ON THIS SHEET UNLESS OTHERWISE NOTED.
 14. FINISHED FLOOR LEVELS SHALL BE AS SHOWN ON THIS SHEET UNLESS OTHERWISE NOTED.
 15. FINISHED FLOOR LEVELS SHALL BE AS SHOWN ON THIS SHEET UNLESS OTHERWISE NOTED.
 16. FINISHED FLOOR LEVELS SHALL BE AS SHOWN ON THIS SHEET UNLESS OTHERWISE NOTED.
 17. FINISHED FLOOR LEVELS SHALL BE AS SHOWN ON THIS SHEET UNLESS OTHERWISE NOTED.



Mustang Public Schools
 COUNTY LINE ELEMENTARY
 Oklahoma City, OK

DATE: 11/20/2012
 BY: JWP
 1. 10/20/12

PROJECT: COUNTY LINE ELEMENTARY
 FLOOR PLAN AREA C

A2.4

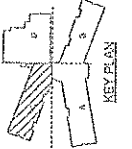
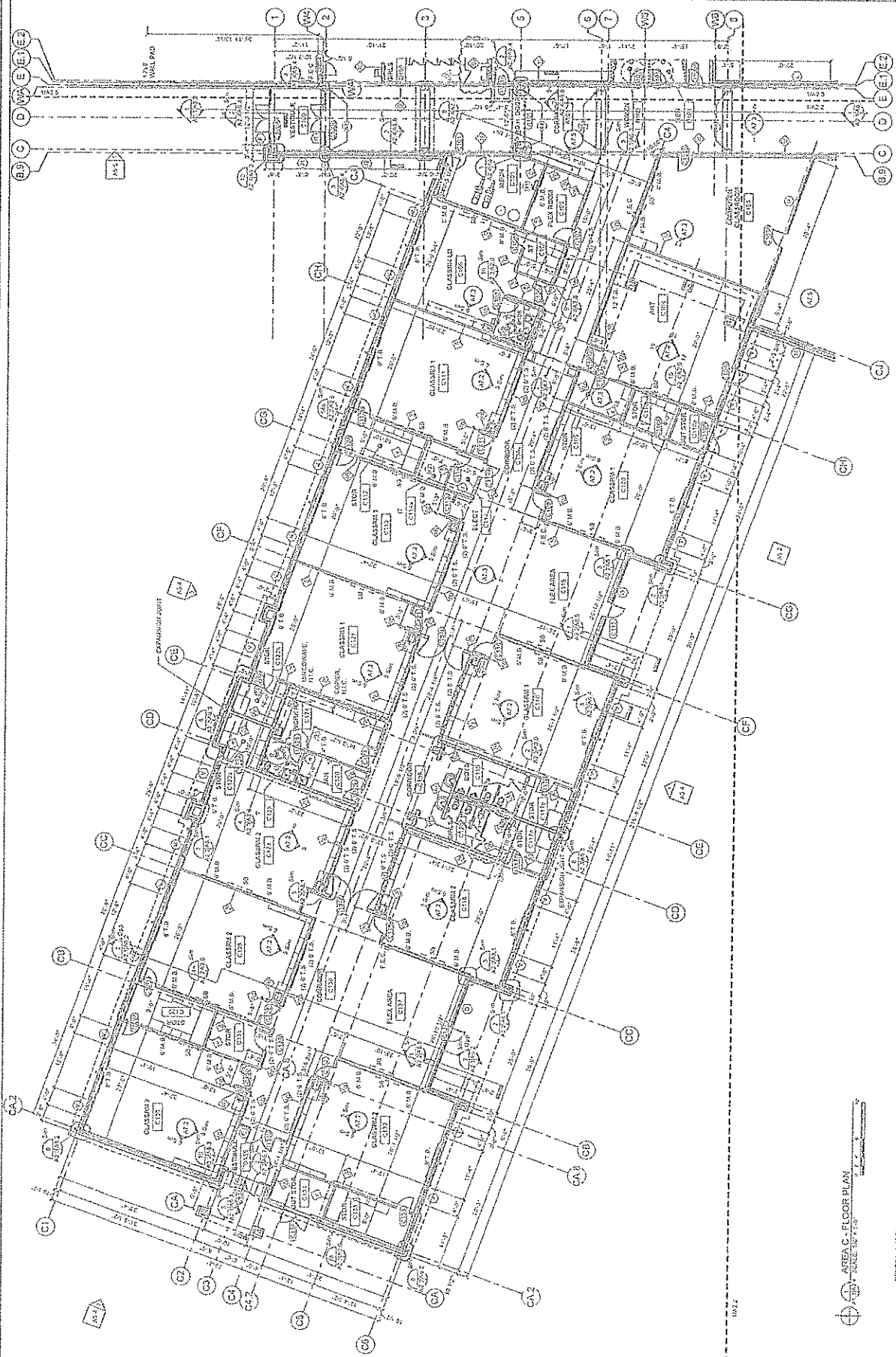

- REVISIONS:**
1. REFER TO SECURITY ANALYSIS DATED FOR DOCUMENTS, RISERS AND SPECIAL CONDITIONS
 2. ALL WALLS TO BE TYPED, FINISHED, PAINTED, IN TWO PART WALLS IN THIS ROOM.
 3. PROVIDE COORDING FOR WALL WALLS INCLUDING, GASTROCK, T.N.S., T.L., J.B., S.B., AND S.W. WALLS.
 4. PROVIDE COORDING FOR WALL WALLS INCLUDING, GASTROCK, T.N.S., T.L., J.B., S.B., AND S.W. WALLS.
 5. PROVIDE COORDING FOR WALL WALLS INCLUDING, GASTROCK, T.N.S., T.L., J.B., S.B., AND S.W. WALLS.
- GENERAL NOTES:**
1. FINISHED FLOOR TO BE AS SHOWN.
 2. ALL WALLS TO BE TYPED, FINISHED, PAINTED, IN TWO PART WALLS IN THIS ROOM.
 3. PROVIDE COORDING FOR WALL WALLS INCLUDING, GASTROCK, T.N.S., T.L., J.B., S.B., AND S.W. WALLS.
 4. PROVIDE COORDING FOR WALL WALLS INCLUDING, GASTROCK, T.N.S., T.L., J.B., S.B., AND S.W. WALLS.
 5. PROVIDE COORDING FOR WALL WALLS INCLUDING, GASTROCK, T.N.S., T.L., J.B., S.B., AND S.W. WALLS.
 6. PROVIDE COORDING FOR WALL WALLS INCLUDING, GASTROCK, T.N.S., T.L., J.B., S.B., AND S.W. WALLS.
 7. PROVIDE COORDING FOR WALL WALLS INCLUDING, GASTROCK, T.N.S., T.L., J.B., S.B., AND S.W. WALLS.
 8. PROVIDE COORDING FOR WALL WALLS INCLUDING, GASTROCK, T.N.S., T.L., J.B., S.B., AND S.W. WALLS.
 9. PROVIDE COORDING FOR WALL WALLS INCLUDING, GASTROCK, T.N.S., T.L., J.B., S.B., AND S.W. WALLS.
 10. PROVIDE COORDING FOR WALL WALLS INCLUDING, GASTROCK, T.N.S., T.L., J.B., S.B., AND S.W. WALLS.
 11. PROVIDE COORDING FOR WALL WALLS INCLUDING, GASTROCK, T.N.S., T.L., J.B., S.B., AND S.W. WALLS.
 12. PROVIDE COORDING FOR WALL WALLS INCLUDING, GASTROCK, T.N.S., T.L., J.B., S.B., AND S.W. WALLS.
 13. PROVIDE COORDING FOR WALL WALLS INCLUDING, GASTROCK, T.N.S., T.L., J.B., S.B., AND S.W. WALLS.
 14. PROVIDE COORDING FOR WALL WALLS INCLUDING, GASTROCK, T.N.S., T.L., J.B., S.B., AND S.W. WALLS.
 15. PROVIDE COORDING FOR WALL WALLS INCLUDING, GASTROCK, T.N.S., T.L., J.B., S.B., AND S.W. WALLS.
 16. PROVIDE COORDING FOR WALL WALLS INCLUDING, GASTROCK, T.N.S., T.L., J.B., S.B., AND S.W. WALLS.
 17. PROVIDE COORDING FOR WALL WALLS INCLUDING, GASTROCK, T.N.S., T.L., J.B., S.B., AND S.W. WALLS.
 18. PROVIDE COORDING FOR WALL WALLS INCLUDING, GASTROCK, T.N.S., T.L., J.B., S.B., AND S.W. WALLS.
 19. PROVIDE COORDING FOR WALL WALLS INCLUDING, GASTROCK, T.N.S., T.L., J.B., S.B., AND S.W. WALLS.
 20. PROVIDE COORDING FOR WALL WALLS INCLUDING, GASTROCK, T.N.S., T.L., J.B., S.B., AND S.W. WALLS.

AREA C - FLOOR PLAN
 SCALE: 1/8" = 1'-0"



OKLAHOMA STATE UNIVERSITY
ARCHITECTURAL COLLEGE



Mustang Public Schools COUNTY LINE ELEMENTARY

Oklaoma City, OK

DATE: 11/15/2011
DRAWN: JAC
CHECKED: JAC
PROJECT NO: 11-00000000

FLOOR PLAN AREA
A2.5

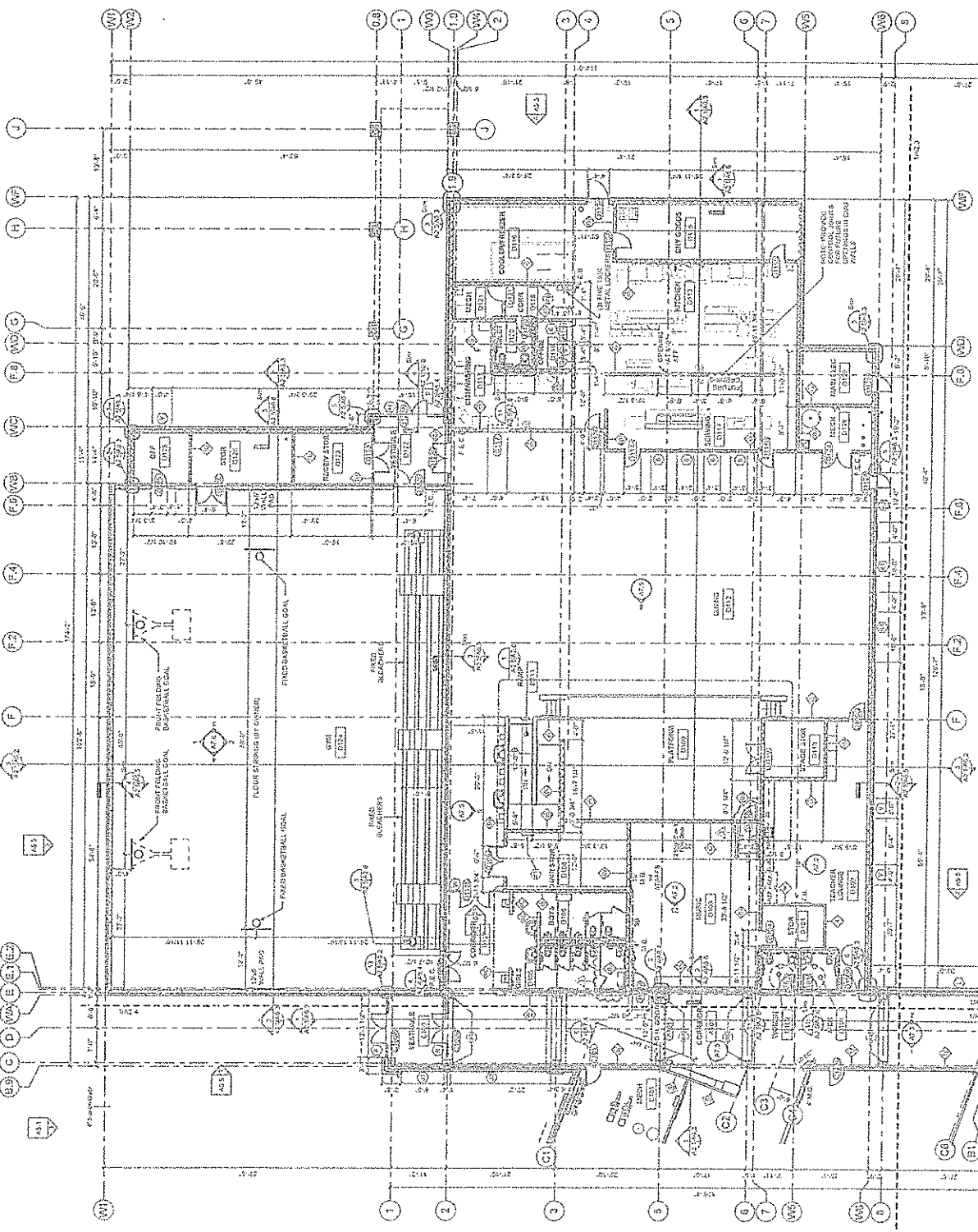
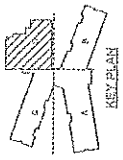

- REVISIONS:**
- 1. REFER TO ACCESSORY SHEET FOR DOOR AND WINDOW SCHEDULES.
 - 2. ALL TASK ROOMS TO BE ACCORDING TO THE CONSTRUCTION DOCUMENTS.
 - 3. PROVIDE A 3" WIDE GROUND LINE FOR ALL WALLS.
 - 4. PROVIDE A 3" WIDE GROUND LINE FOR ALL WALLS.
 - 5. PROVIDE A 3" WIDE GROUND LINE FOR ALL WALLS.
 - 6. PROVIDE A 3" WIDE GROUND LINE FOR ALL WALLS.
 - 7. PROVIDE A 3" WIDE GROUND LINE FOR ALL WALLS.
 - 8. PROVIDE A 3" WIDE GROUND LINE FOR ALL WALLS.
 - 9. PROVIDE A 3" WIDE GROUND LINE FOR ALL WALLS.
 - 10. PROVIDE A 3" WIDE GROUND LINE FOR ALL WALLS.
- NOTES:**
- 1. FINISH FLOOR: 1/2" POLISHED CONCRETE.
 - 2. FINISH WALLS: 5/8" GYP. BOARD OVER STUDS AND TRACKS.
 - 3. FINISH CEILING: 2' X 4' GYP. BOARD.
 - 4. FINISH DOORS: 1 3/4" SOLID CORE.
 - 5. FINISH WINDOWS: 2" ALUMINUM FRAME WITH GLASS.
 - 6. FINISH STAIRS: 1/2" POLISHED CONCRETE.
 - 7. FINISH ELEVATOR: 1/2" POLISHED CONCRETE.
 - 8. FINISH RESTROOMS: 1/2" POLISHED CONCRETE.
 - 9. FINISH PLUMBING: 1/2" POLISHED CONCRETE.
 - 10. FINISH ELECTRICAL: 1/2" POLISHED CONCRETE.

- GENERAL NOTES:**
- 1. REFER TO ACCESSORY SHEET FOR DOOR AND WINDOW SCHEDULES.
 - 2. ALL TASK ROOMS TO BE ACCORDING TO THE CONSTRUCTION DOCUMENTS.
 - 3. PROVIDE A 3" WIDE GROUND LINE FOR ALL WALLS.
 - 4. PROVIDE A 3" WIDE GROUND LINE FOR ALL WALLS.
 - 5. PROVIDE A 3" WIDE GROUND LINE FOR ALL WALLS.
 - 6. PROVIDE A 3" WIDE GROUND LINE FOR ALL WALLS.
 - 7. PROVIDE A 3" WIDE GROUND LINE FOR ALL WALLS.
 - 8. PROVIDE A 3" WIDE GROUND LINE FOR ALL WALLS.
 - 9. PROVIDE A 3" WIDE GROUND LINE FOR ALL WALLS.
 - 10. PROVIDE A 3" WIDE GROUND LINE FOR ALL WALLS.

- REVISIONS:**
- 1. REFER TO ACCESSORY SHEET FOR DOOR AND WINDOW SCHEDULES.
 - 2. ALL TASK ROOMS TO BE ACCORDING TO THE CONSTRUCTION DOCUMENTS.
 - 3. PROVIDE A 3" WIDE GROUND LINE FOR ALL WALLS.
 - 4. PROVIDE A 3" WIDE GROUND LINE FOR ALL WALLS.
 - 5. PROVIDE A 3" WIDE GROUND LINE FOR ALL WALLS.
 - 6. PROVIDE A 3" WIDE GROUND LINE FOR ALL WALLS.
 - 7. PROVIDE A 3" WIDE GROUND LINE FOR ALL WALLS.
 - 8. PROVIDE A 3" WIDE GROUND LINE FOR ALL WALLS.
 - 9. PROVIDE A 3" WIDE GROUND LINE FOR ALL WALLS.
 - 10. PROVIDE A 3" WIDE GROUND LINE FOR ALL WALLS.

AREA D - FLOOR PLAN
A2.5



COUNTY LINE ELEMENTARY

Oklahoma City, OK

Mustang Public Schools

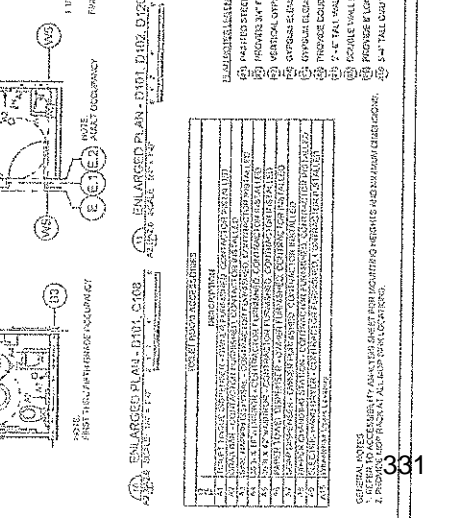
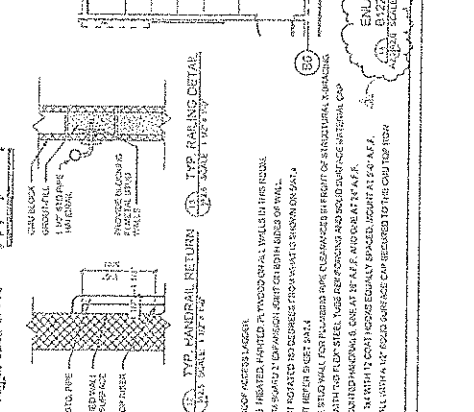
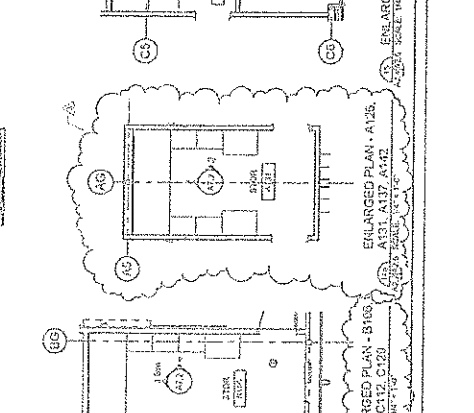
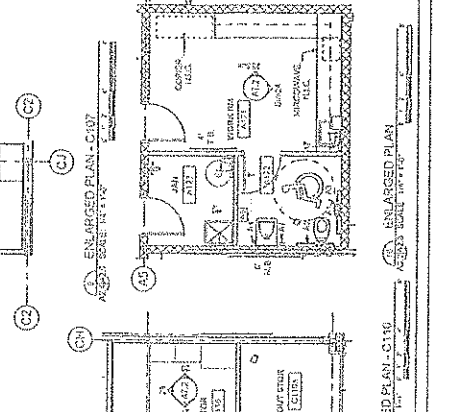
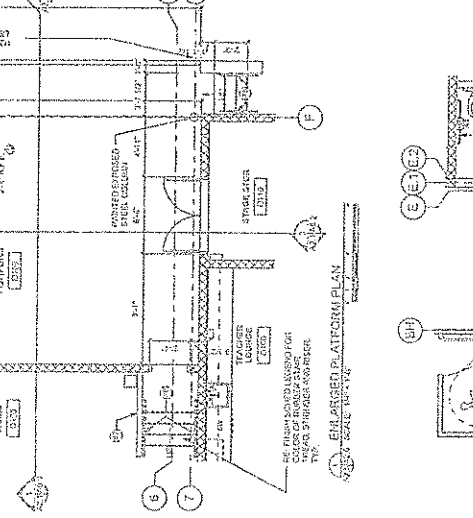
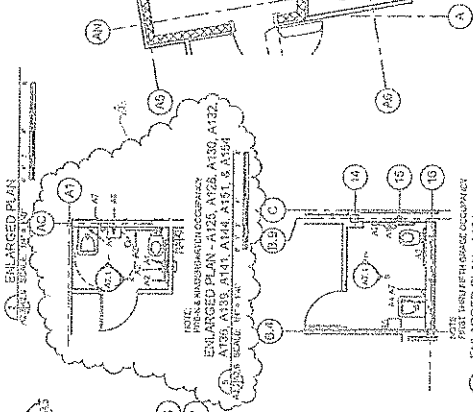
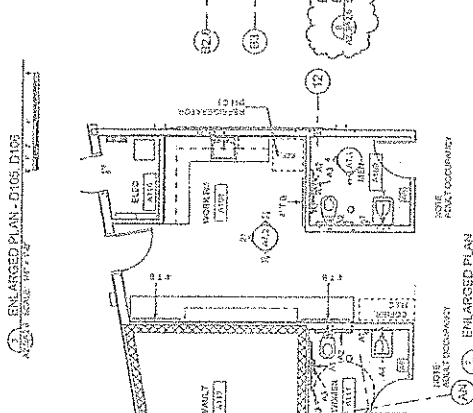
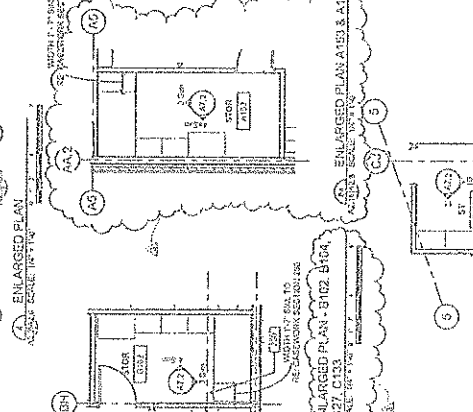
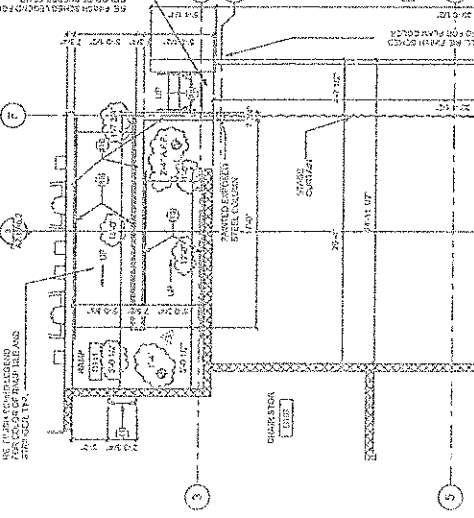
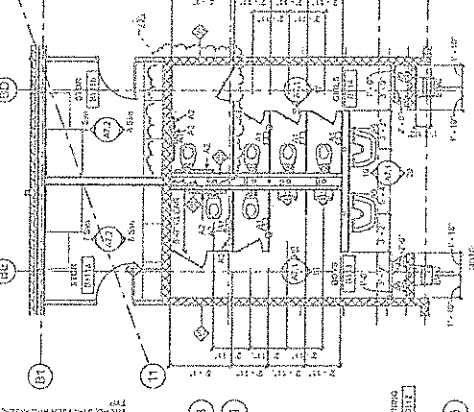
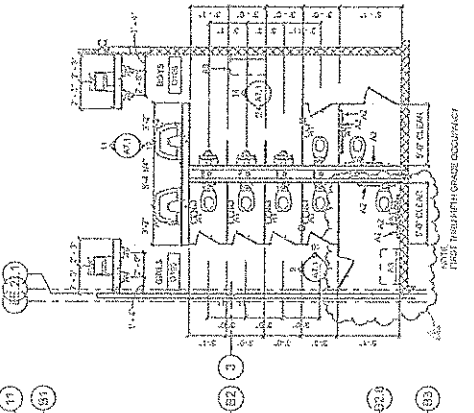
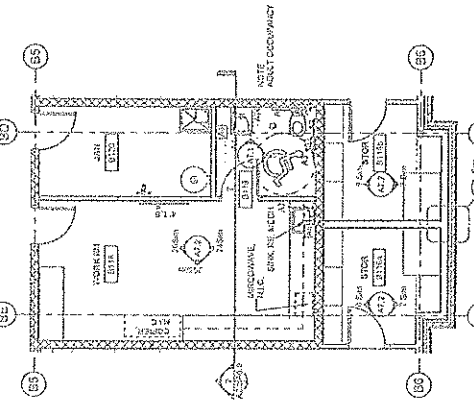

NO.	DESCRIPTION
1	SEE GENERAL NOTES
2	SEE GENERAL NOTES
3	SEE GENERAL NOTES
4	SEE GENERAL NOTES
5	SEE GENERAL NOTES
6	SEE GENERAL NOTES
7	SEE GENERAL NOTES
8	SEE GENERAL NOTES
9	SEE GENERAL NOTES
10	SEE GENERAL NOTES
11	SEE GENERAL NOTES
12	SEE GENERAL NOTES
13	SEE GENERAL NOTES
14	SEE GENERAL NOTES
15	SEE GENERAL NOTES
16	SEE GENERAL NOTES
17	SEE GENERAL NOTES
18	SEE GENERAL NOTES
19	SEE GENERAL NOTES
20	SEE GENERAL NOTES
21	SEE GENERAL NOTES
22	SEE GENERAL NOTES
23	SEE GENERAL NOTES
24	SEE GENERAL NOTES
25	SEE GENERAL NOTES
26	SEE GENERAL NOTES
27	SEE GENERAL NOTES
28	SEE GENERAL NOTES
29	SEE GENERAL NOTES
30	SEE GENERAL NOTES
31	SEE GENERAL NOTES
32	SEE GENERAL NOTES
33	SEE GENERAL NOTES
34	SEE GENERAL NOTES
35	SEE GENERAL NOTES
36	SEE GENERAL NOTES
37	SEE GENERAL NOTES
38	SEE GENERAL NOTES
39	SEE GENERAL NOTES
40	SEE GENERAL NOTES
41	SEE GENERAL NOTES
42	SEE GENERAL NOTES
43	SEE GENERAL NOTES
44	SEE GENERAL NOTES
45	SEE GENERAL NOTES
46	SEE GENERAL NOTES
47	SEE GENERAL NOTES
48	SEE GENERAL NOTES
49	SEE GENERAL NOTES
50	SEE GENERAL NOTES
51	SEE GENERAL NOTES
52	SEE GENERAL NOTES
53	SEE GENERAL NOTES
54	SEE GENERAL NOTES
55	SEE GENERAL NOTES
56	SEE GENERAL NOTES
57	SEE GENERAL NOTES
58	SEE GENERAL NOTES
59	SEE GENERAL NOTES
60	SEE GENERAL NOTES
61	SEE GENERAL NOTES
62	SEE GENERAL NOTES
63	SEE GENERAL NOTES
64	SEE GENERAL NOTES
65	SEE GENERAL NOTES
66	SEE GENERAL NOTES
67	SEE GENERAL NOTES
68	SEE GENERAL NOTES
69	SEE GENERAL NOTES
70	SEE GENERAL NOTES
71	SEE GENERAL NOTES
72	SEE GENERAL NOTES
73	SEE GENERAL NOTES
74	SEE GENERAL NOTES
75	SEE GENERAL NOTES
76	SEE GENERAL NOTES
77	SEE GENERAL NOTES
78	SEE GENERAL NOTES
79	SEE GENERAL NOTES
80	SEE GENERAL NOTES
81	SEE GENERAL NOTES
82	SEE GENERAL NOTES
83	SEE GENERAL NOTES
84	SEE GENERAL NOTES
85	SEE GENERAL NOTES
86	SEE GENERAL NOTES
87	SEE GENERAL NOTES
88	SEE GENERAL NOTES
89	SEE GENERAL NOTES
90	SEE GENERAL NOTES
91	SEE GENERAL NOTES
92	SEE GENERAL NOTES
93	SEE GENERAL NOTES
94	SEE GENERAL NOTES
95	SEE GENERAL NOTES
96	SEE GENERAL NOTES
97	SEE GENERAL NOTES
98	SEE GENERAL NOTES
99	SEE GENERAL NOTES
100	SEE GENERAL NOTES

A2.6



SWP&E
 Structural, Welding, Painting, Electrical, Mechanical, Plumbing, Fire Protection, and Energy Services
 1000 N. Lincoln Blvd., Suite 100
 Oklahoma City, Oklahoma 73102
 (405) 241-2222



COUNTY LINE ELEMENTARY

Mustang Public Schools

Oklahoma City, OK

DATE: 05/14/19
 USER: JPH/ML
 PROJECT: 19030001

CONTRACT: 19030001

A2.16

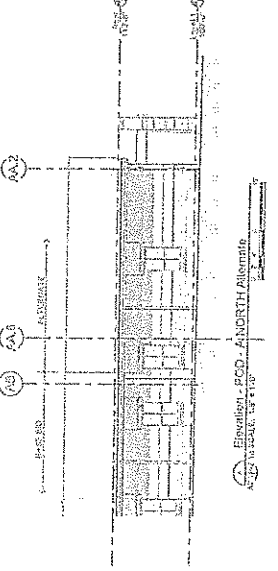
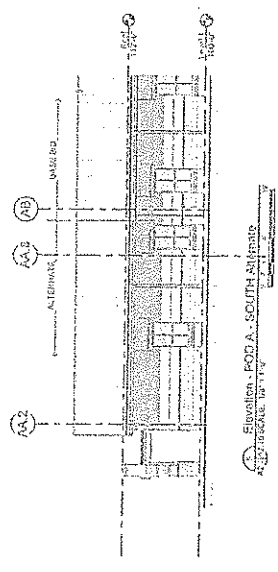
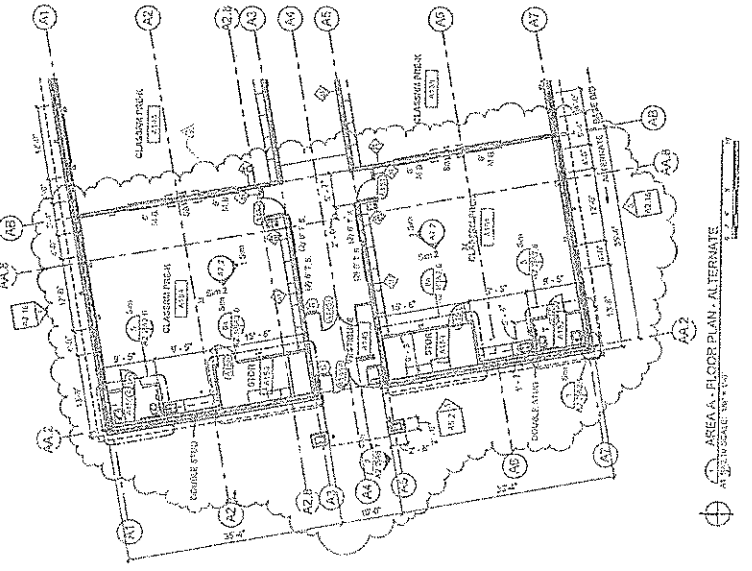
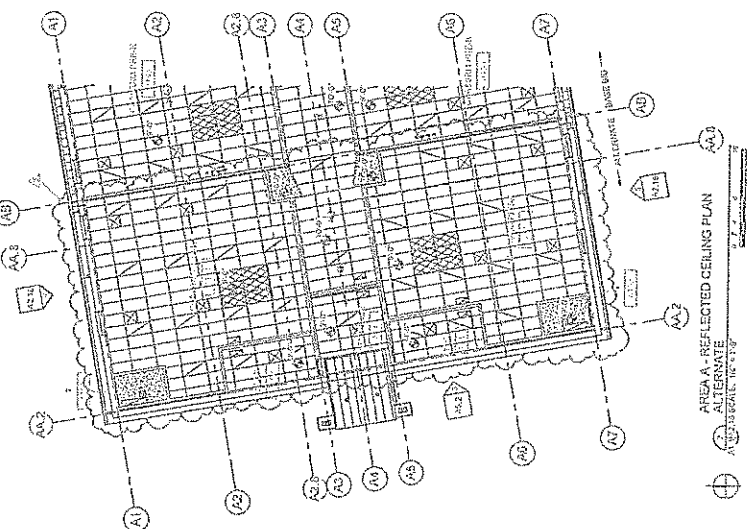
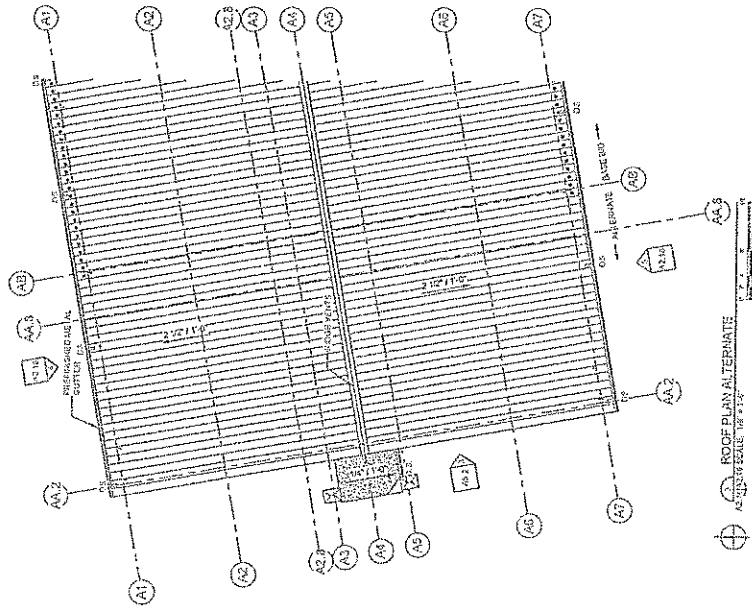



Mustung Public Schools
 COUNTY LINE ELEMENTARY
 Oklahoma City, OK

DATE: 10/23/19
 DRAWN BY: [Name]
 CHECKED BY: [Name]
 PROJECT NO: [Number]
 SHEET NO: [Number]
 TOTAL SHEETS: [Number]

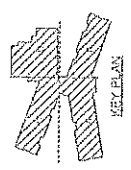

A3.1

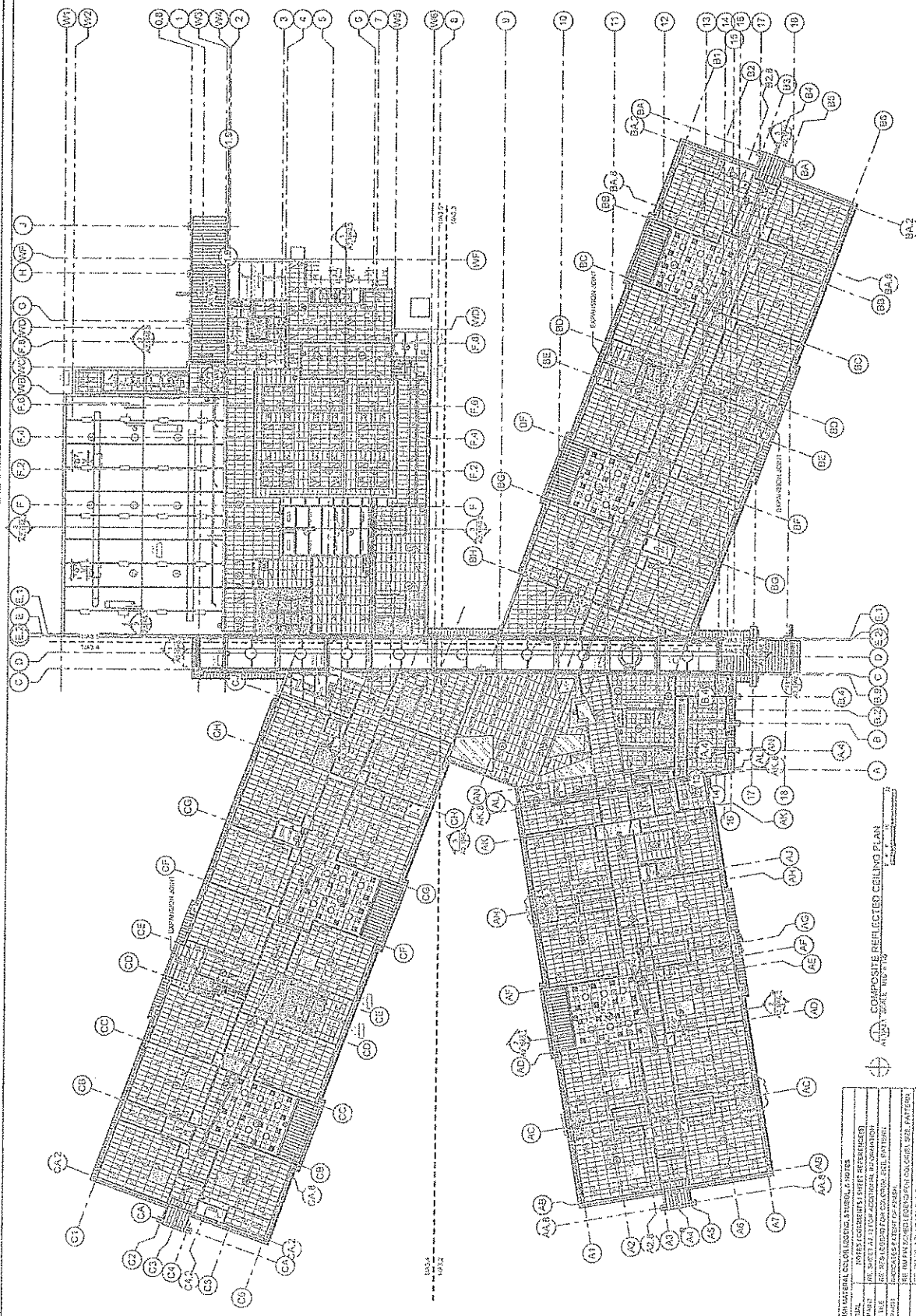

NO.	DESCRIPTION	DATE
1	REVISION	
2	REVISION	
3	REVISION	
4	REVISION	
5	REVISION	
6	REVISION	
7	REVISION	
8	REVISION	
9	REVISION	
10	REVISION	
11	REVISION	
12	REVISION	
13	REVISION	
14	REVISION	
15	REVISION	
16	REVISION	
17	REVISION	
18	REVISION	
19	REVISION	
20	REVISION	
21	REVISION	
22	REVISION	
23	REVISION	
24	REVISION	
25	REVISION	
26	REVISION	
27	REVISION	
28	REVISION	
29	REVISION	
30	REVISION	
31	REVISION	
32	REVISION	
33	REVISION	
34	REVISION	
35	REVISION	
36	REVISION	
37	REVISION	
38	REVISION	
39	REVISION	
40	REVISION	
41	REVISION	
42	REVISION	
43	REVISION	
44	REVISION	
45	REVISION	
46	REVISION	
47	REVISION	
48	REVISION	
49	REVISION	
50	REVISION	
51	REVISION	
52	REVISION	
53	REVISION	
54	REVISION	
55	REVISION	
56	REVISION	
57	REVISION	
58	REVISION	
59	REVISION	
60	REVISION	
61	REVISION	
62	REVISION	
63	REVISION	
64	REVISION	
65	REVISION	
66	REVISION	
67	REVISION	
68	REVISION	
69	REVISION	
70	REVISION	
71	REVISION	
72	REVISION	
73	REVISION	
74	REVISION	
75	REVISION	
76	REVISION	
77	REVISION	
78	REVISION	
79	REVISION	
80	REVISION	
81	REVISION	
82	REVISION	
83	REVISION	
84	REVISION	
85	REVISION	
86	REVISION	
87	REVISION	
88	REVISION	
89	REVISION	
90	REVISION	
91	REVISION	
92	REVISION	
93	REVISION	
94	REVISION	
95	REVISION	
96	REVISION	
97	REVISION	
98	REVISION	
99	REVISION	
100	REVISION	

COMPOSITE REFLECTED CEILING PLAN
 SCALE: 1/8" = 1'-0"

ORIGINAL NOTES:
 1. REFER TO SHEET A3.1 FOR CEILING PLAN
 2. REFER TO SHEET A3.2 FOR CEILING PLAN
 3. REFER TO SHEET A3.3 FOR CEILING PLAN



COUNTY LINE ELEMENTARY

Mustang Public Schools

Oklahoma City, OK

DATE: 04/14/11
BY: JMM

PROJECT: COUNTY LINE ELEMENTARY

A3.2

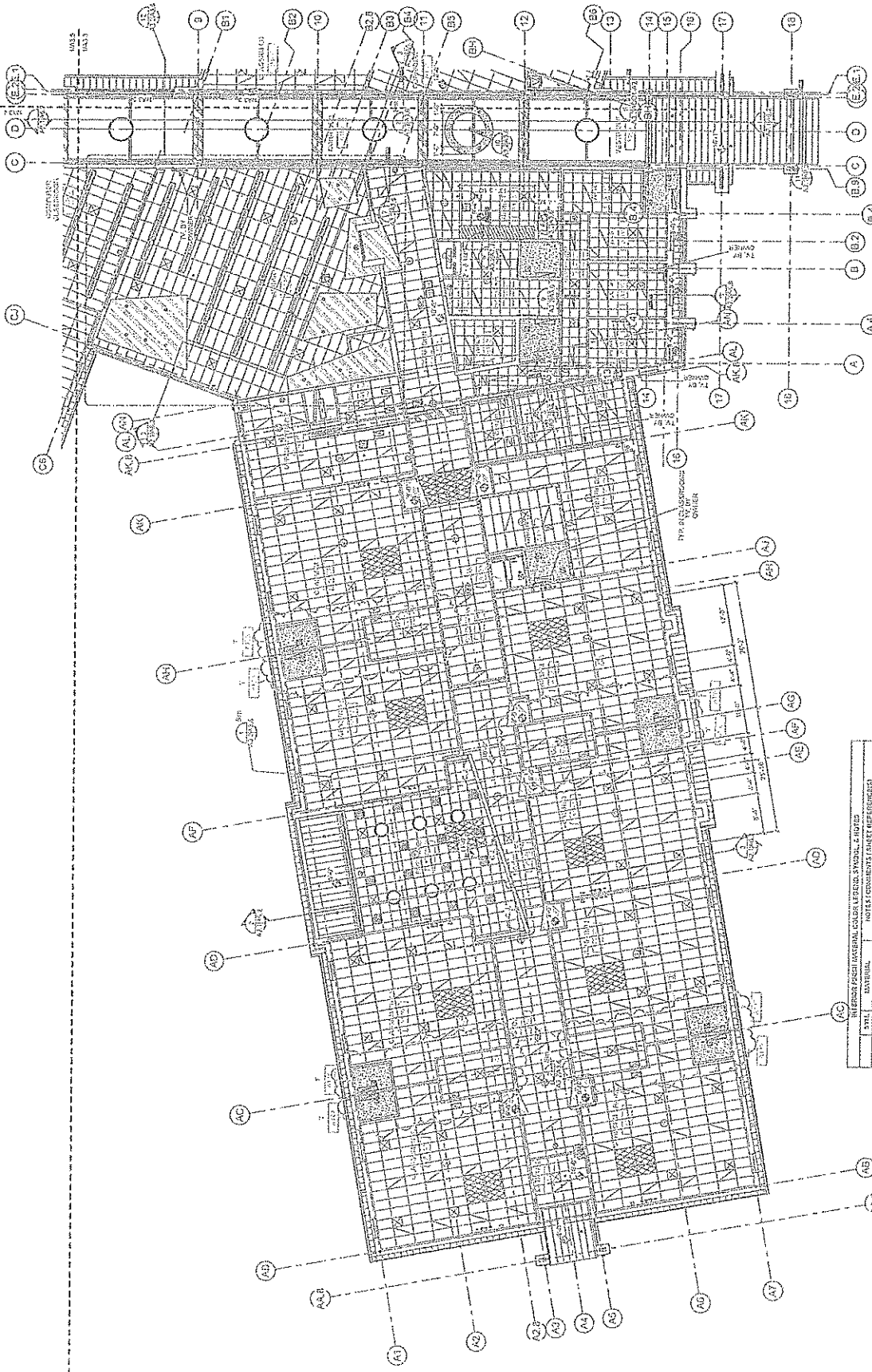

GENERAL NOTES:
1. ALL GRASS IS TO BE MAINTAINED AS EXISTING UNLESS OTHERWISE NOTED.
2. ALL EXISTING UTILITIES TO BE PROTECTED AND NOT TO BE MOVED UNLESS OTHERWISE NOTED.

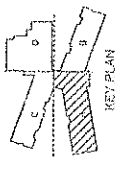

SYMBOL	DESCRIPTION
	STRUCTURAL STEEL DECK
	STRUCTURAL STEEL JOIST
	STRUCTURAL STEEL BEAM
	STRUCTURAL STEEL COLUMN
	STRUCTURAL STEEL WALL
	STRUCTURAL STEEL FLOOR DECK
	STRUCTURAL STEEL ROOF DECK
	STRUCTURAL STEEL TRUSS
	STRUCTURAL STEEL JOIST AND BEAM
	STRUCTURAL STEEL JOIST AND COLUMN
	STRUCTURAL STEEL JOIST AND WALL
	STRUCTURAL STEEL JOIST AND FLOOR DECK
	STRUCTURAL STEEL JOIST AND ROOF DECK
	STRUCTURAL STEEL JOIST AND TRUSS
	STRUCTURAL STEEL JOIST AND WALL AND FLOOR DECK
	STRUCTURAL STEEL JOIST AND WALL AND ROOF DECK
	STRUCTURAL STEEL JOIST AND WALL AND TRUSS
	STRUCTURAL STEEL JOIST AND WALL AND FLOOR DECK AND ROOF DECK
	STRUCTURAL STEEL JOIST AND WALL AND FLOOR DECK AND TRUSS
	STRUCTURAL STEEL JOIST AND WALL AND ROOF DECK AND TRUSS
	STRUCTURAL STEEL JOIST AND WALL AND FLOOR DECK AND ROOF DECK AND TRUSS

SYMBOL	DESCRIPTION
	STRUCTURAL STEEL DECK
	STRUCTURAL STEEL JOIST
	STRUCTURAL STEEL BEAM
	STRUCTURAL STEEL COLUMN
	STRUCTURAL STEEL WALL
	STRUCTURAL STEEL FLOOR DECK
	STRUCTURAL STEEL ROOF DECK
	STRUCTURAL STEEL TRUSS
	STRUCTURAL STEEL JOIST AND BEAM
	STRUCTURAL STEEL JOIST AND COLUMN
	STRUCTURAL STEEL JOIST AND WALL
	STRUCTURAL STEEL JOIST AND FLOOR DECK
	STRUCTURAL STEEL JOIST AND ROOF DECK
	STRUCTURAL STEEL JOIST AND TRUSS
	STRUCTURAL STEEL JOIST AND WALL AND FLOOR DECK
	STRUCTURAL STEEL JOIST AND WALL AND ROOF DECK
	STRUCTURAL STEEL JOIST AND WALL AND TRUSS
	STRUCTURAL STEEL JOIST AND WALL AND FLOOR DECK AND ROOF DECK
	STRUCTURAL STEEL JOIST AND WALL AND FLOOR DECK AND TRUSS
	STRUCTURAL STEEL JOIST AND WALL AND ROOF DECK AND TRUSS
	STRUCTURAL STEEL JOIST AND WALL AND FLOOR DECK AND ROOF DECK AND TRUSS

AREA A - REFLECTED CEILING PLAN
AREA A - WALL TO WALL

NOTES:
1. REFLECTED CEILING PLAN.
2. AREA A - WALL TO WALL.



COUNTY LINE ELEMENTARY

Mustang Public Schools
Oklahoma City, OK

DATE: 11/19/14
NO. 1001
SHEET 22 OF 27
DRAWN BY

SWANVILLE
PROJECT ARCHITECTS

A7.1

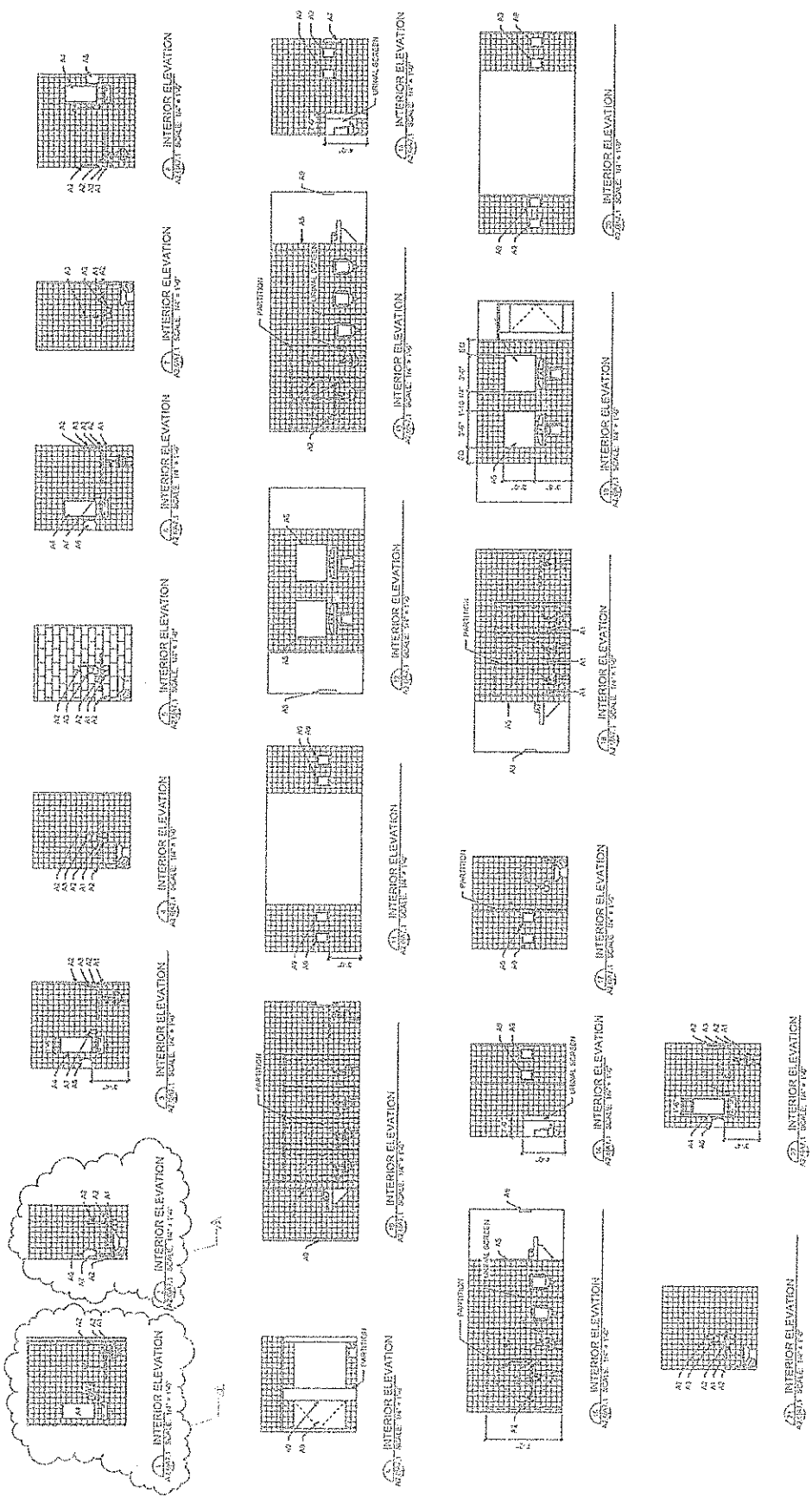

LEGEND - INTERIOR FINISH MATERIALS

NO.	SYMBOL	DESCRIPTION
1	(Symbol)	ACRYLIC PAINT
2	(Symbol)	ACRYLIC PAINT
3	(Symbol)	ACRYLIC PAINT
4	(Symbol)	ACRYLIC PAINT
5	(Symbol)	ACRYLIC PAINT
6	(Symbol)	ACRYLIC PAINT
7	(Symbol)	ACRYLIC PAINT
8	(Symbol)	ACRYLIC PAINT
9	(Symbol)	ACRYLIC PAINT
10	(Symbol)	ACRYLIC PAINT
11	(Symbol)	ACRYLIC PAINT
12	(Symbol)	ACRYLIC PAINT
13	(Symbol)	ACRYLIC PAINT
14	(Symbol)	ACRYLIC PAINT
15	(Symbol)	ACRYLIC PAINT
16	(Symbol)	ACRYLIC PAINT
17	(Symbol)	ACRYLIC PAINT
18	(Symbol)	ACRYLIC PAINT
19	(Symbol)	ACRYLIC PAINT
20	(Symbol)	ACRYLIC PAINT
21	(Symbol)	ACRYLIC PAINT
22	(Symbol)	ACRYLIC PAINT
23	(Symbol)	ACRYLIC PAINT
24	(Symbol)	ACRYLIC PAINT
25	(Symbol)	ACRYLIC PAINT
26	(Symbol)	ACRYLIC PAINT
27	(Symbol)	ACRYLIC PAINT
28	(Symbol)	ACRYLIC PAINT
29	(Symbol)	ACRYLIC PAINT
30	(Symbol)	ACRYLIC PAINT
31	(Symbol)	ACRYLIC PAINT
32	(Symbol)	ACRYLIC PAINT
33	(Symbol)	ACRYLIC PAINT
34	(Symbol)	ACRYLIC PAINT
35	(Symbol)	ACRYLIC PAINT
36	(Symbol)	ACRYLIC PAINT
37	(Symbol)	ACRYLIC PAINT
38	(Symbol)	ACRYLIC PAINT
39	(Symbol)	ACRYLIC PAINT
40	(Symbol)	ACRYLIC PAINT
41	(Symbol)	ACRYLIC PAINT
42	(Symbol)	ACRYLIC PAINT
43	(Symbol)	ACRYLIC PAINT
44	(Symbol)	ACRYLIC PAINT
45	(Symbol)	ACRYLIC PAINT
46	(Symbol)	ACRYLIC PAINT
47	(Symbol)	ACRYLIC PAINT
48	(Symbol)	ACRYLIC PAINT
49	(Symbol)	ACRYLIC PAINT
50	(Symbol)	ACRYLIC PAINT
51	(Symbol)	ACRYLIC PAINT
52	(Symbol)	ACRYLIC PAINT
53	(Symbol)	ACRYLIC PAINT
54	(Symbol)	ACRYLIC PAINT
55	(Symbol)	ACRYLIC PAINT
56	(Symbol)	ACRYLIC PAINT
57	(Symbol)	ACRYLIC PAINT
58	(Symbol)	ACRYLIC PAINT
59	(Symbol)	ACRYLIC PAINT
60	(Symbol)	ACRYLIC PAINT
61	(Symbol)	ACRYLIC PAINT
62	(Symbol)	ACRYLIC PAINT
63	(Symbol)	ACRYLIC PAINT
64	(Symbol)	ACRYLIC PAINT
65	(Symbol)	ACRYLIC PAINT
66	(Symbol)	ACRYLIC PAINT
67	(Symbol)	ACRYLIC PAINT
68	(Symbol)	ACRYLIC PAINT
69	(Symbol)	ACRYLIC PAINT
70	(Symbol)	ACRYLIC PAINT
71	(Symbol)	ACRYLIC PAINT
72	(Symbol)	ACRYLIC PAINT
73	(Symbol)	ACRYLIC PAINT
74	(Symbol)	ACRYLIC PAINT
75	(Symbol)	ACRYLIC PAINT
76	(Symbol)	ACRYLIC PAINT
77	(Symbol)	ACRYLIC PAINT
78	(Symbol)	ACRYLIC PAINT
79	(Symbol)	ACRYLIC PAINT
80	(Symbol)	ACRYLIC PAINT
81	(Symbol)	ACRYLIC PAINT
82	(Symbol)	ACRYLIC PAINT
83	(Symbol)	ACRYLIC PAINT
84	(Symbol)	ACRYLIC PAINT
85	(Symbol)	ACRYLIC PAINT
86	(Symbol)	ACRYLIC PAINT
87	(Symbol)	ACRYLIC PAINT
88	(Symbol)	ACRYLIC PAINT
89	(Symbol)	ACRYLIC PAINT
90	(Symbol)	ACRYLIC PAINT
91	(Symbol)	ACRYLIC PAINT
92	(Symbol)	ACRYLIC PAINT
93	(Symbol)	ACRYLIC PAINT
94	(Symbol)	ACRYLIC PAINT
95	(Symbol)	ACRYLIC PAINT
96	(Symbol)	ACRYLIC PAINT
97	(Symbol)	ACRYLIC PAINT
98	(Symbol)	ACRYLIC PAINT
99	(Symbol)	ACRYLIC PAINT
100	(Symbol)	ACRYLIC PAINT

1. REFER TO ROOM FINISH SCHEDULES FOR COLOR AND FINISH.
2. FINISHES FOR AREAS THAT HAVE MULTIPLE TYPES OF FINISHES SHOULD BE IDENTIFIED BY CALLING OUT THE FINISH TYPE AND COLOR TO THE WALL OR CEILING.
3. LEGEND SYMBOLS ARE SCHEDULES AS SHOWN IN THE FINISH SCHEDULES FOR ALL WALL, FLOOR, AND CEILING FINISHES.
4. REFER TO THE FINISH SCHEDULES FOR ALL WALL, FLOOR, AND CEILING FINISHES.
5. REFER TO THE FINISH SCHEDULES FOR ALL WALL, FLOOR, AND CEILING FINISHES.
6. REFER TO THE FINISH SCHEDULES FOR ALL WALL, FLOOR, AND CEILING FINISHES.
7. REFER TO THE FINISH SCHEDULES FOR ALL WALL, FLOOR, AND CEILING FINISHES.
8. REFER TO THE FINISH SCHEDULES FOR ALL WALL, FLOOR, AND CEILING FINISHES.
9. REFER TO THE FINISH SCHEDULES FOR ALL WALL, FLOOR, AND CEILING FINISHES.
10. REFER TO THE FINISH SCHEDULES FOR ALL WALL, FLOOR, AND CEILING FINISHES.

SWANVILLE PROJECT ARCHITECTS

DATE: 11/19/14
NO. 1001
SHEET 22 OF 27
DRAWN BY

A7.1



ALLEN ENGINEERING & ARCHITECTURE
1000 N. W. 10th St.
Oklahoma City, OK 73102
Tel: (405) 241-1111
Fax: (405) 241-1112



MUSTANG PUBLIC SCHOOLS COUNTY LINE ELEMENTARY

Oklahoma City, OK

DATE: 05/04/04
SCALE: AS SHOWN
PROJECT NO: 04-00000000

WATER SERVICE PLAN
PLANS

MO.1

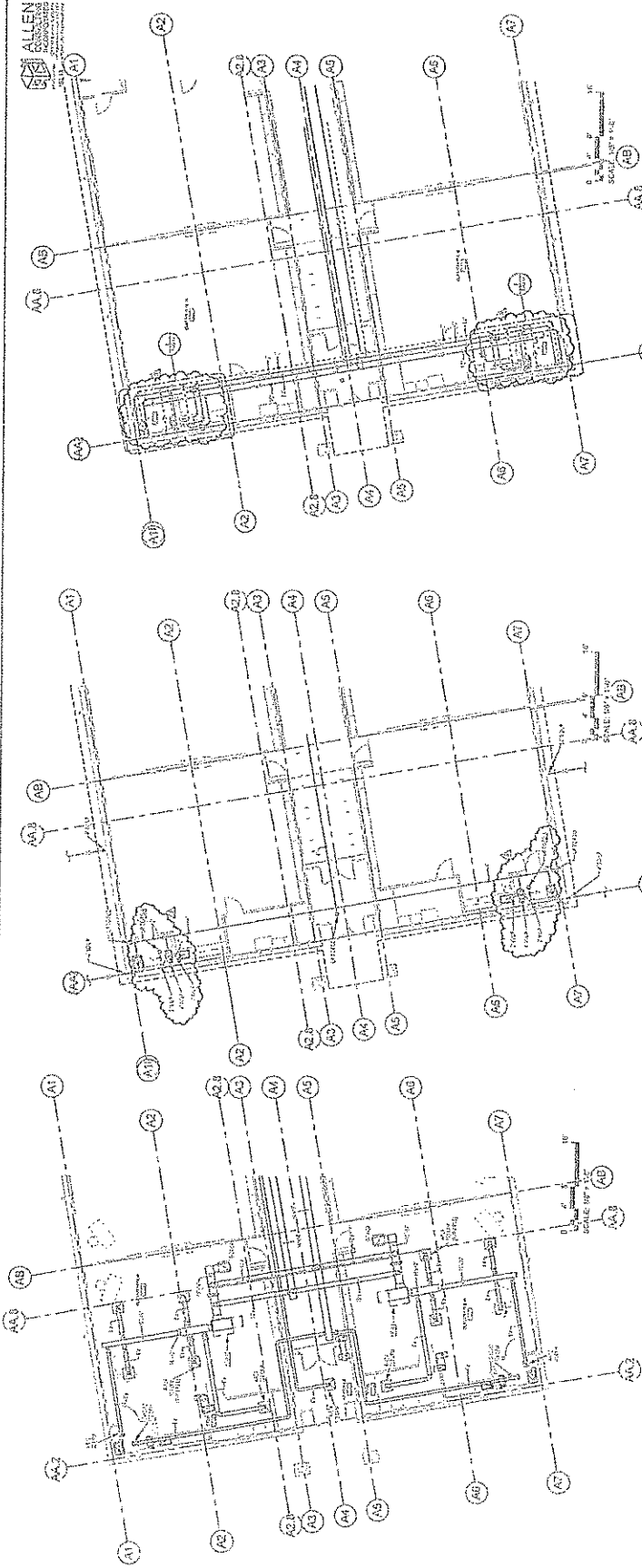

A MECHANICAL PLAN - AREA A ALTERNATE
SCALE: 1/8" = 1'-0"

B UNDERFLOOR PLUMBING PLAN - AREA A ALTERNATE
SCALE: 1/8" = 1'-0"

C ABOVEFLOOR PLUMBING PLAN - AREA A ALTERNATE
SCALE: 1/8" = 1'-0"



Mustang Public Schools
 COUNTY LINE ELEMENTARY
 Oklahoma City, OK

DATE: 04/20/11
 BY: J. W. B. / J. W. B.
 PROJECT: COUNTY LINE ELEMENTARY
 SHEET NO. M4.1

MUSTANG PUBLIC SCHOOLS
 COUNTY LINE ELEMENTARY
 PART AREA A

M4.1

ALLEN
 ARCHITECTS
 1000 N. W. 10th St.
 Oklahoma City, OK 73102

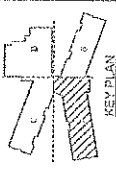
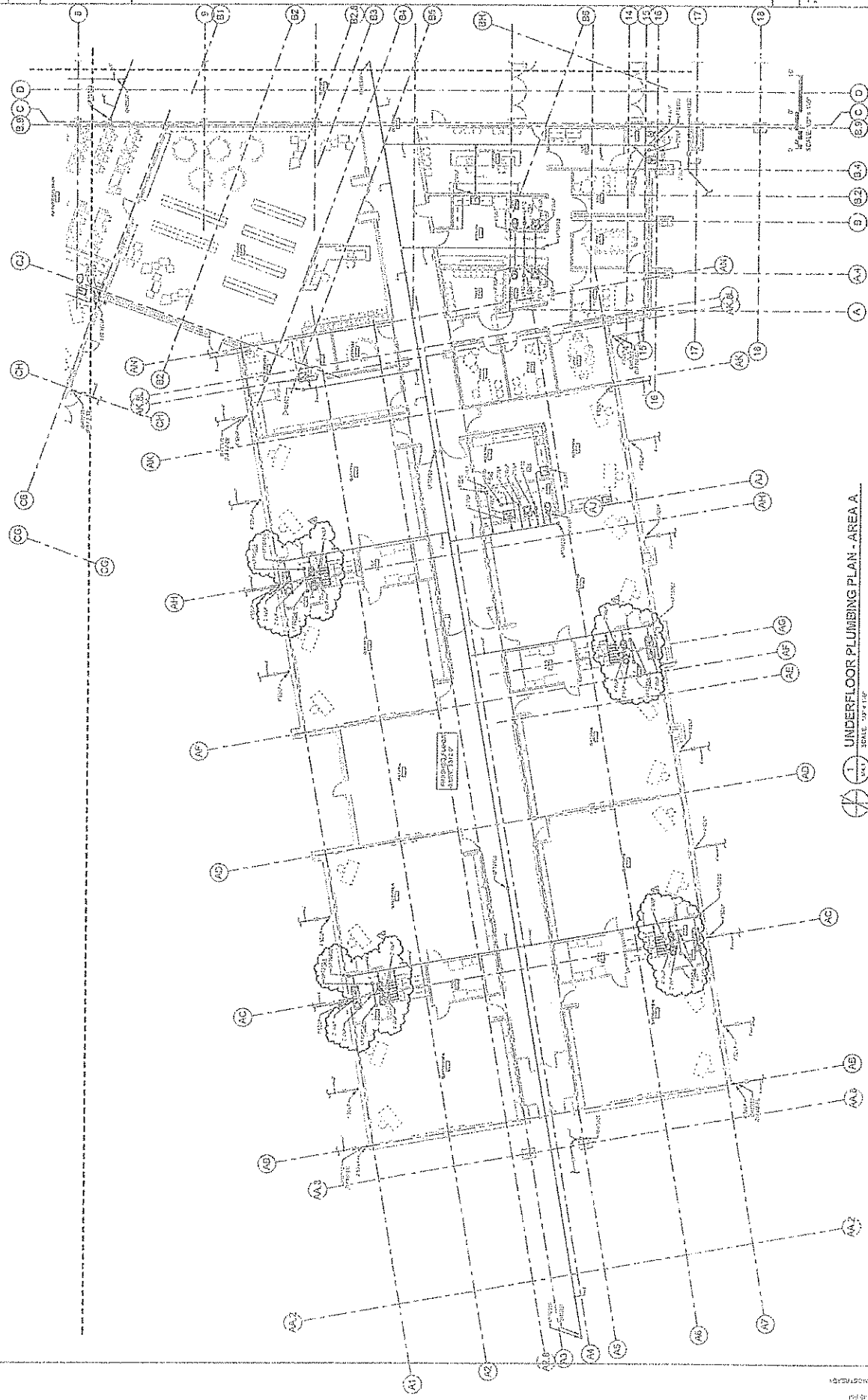

1 UNDERFLOOR PLUMBING PLAN - AREA A
 SCALE: 1/8" = 1'-0"





Mustang Public Schools
 COUNTY LINE ELEMENTARY
 Oklahoma City, OK

DATE: 04/20/2011
 SHEET: 0043
 PROJECT: COUNTY LINE
 DRAWING: PLUMBING

MUSTANG PUBLIC SCHOOLS
 COUNTY LINE ELEMENTARY
 PLUMBING - AREA B
M4.2

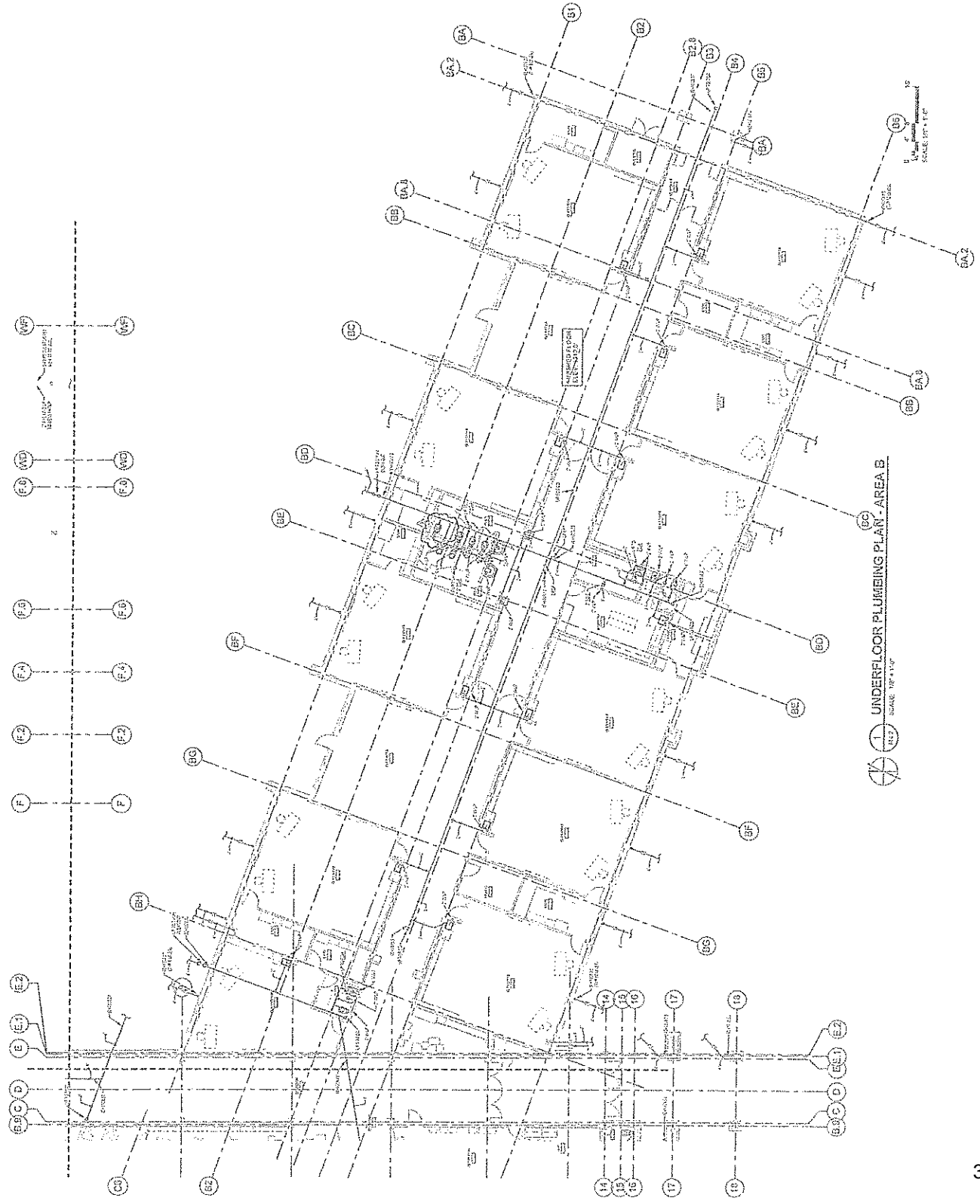
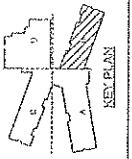

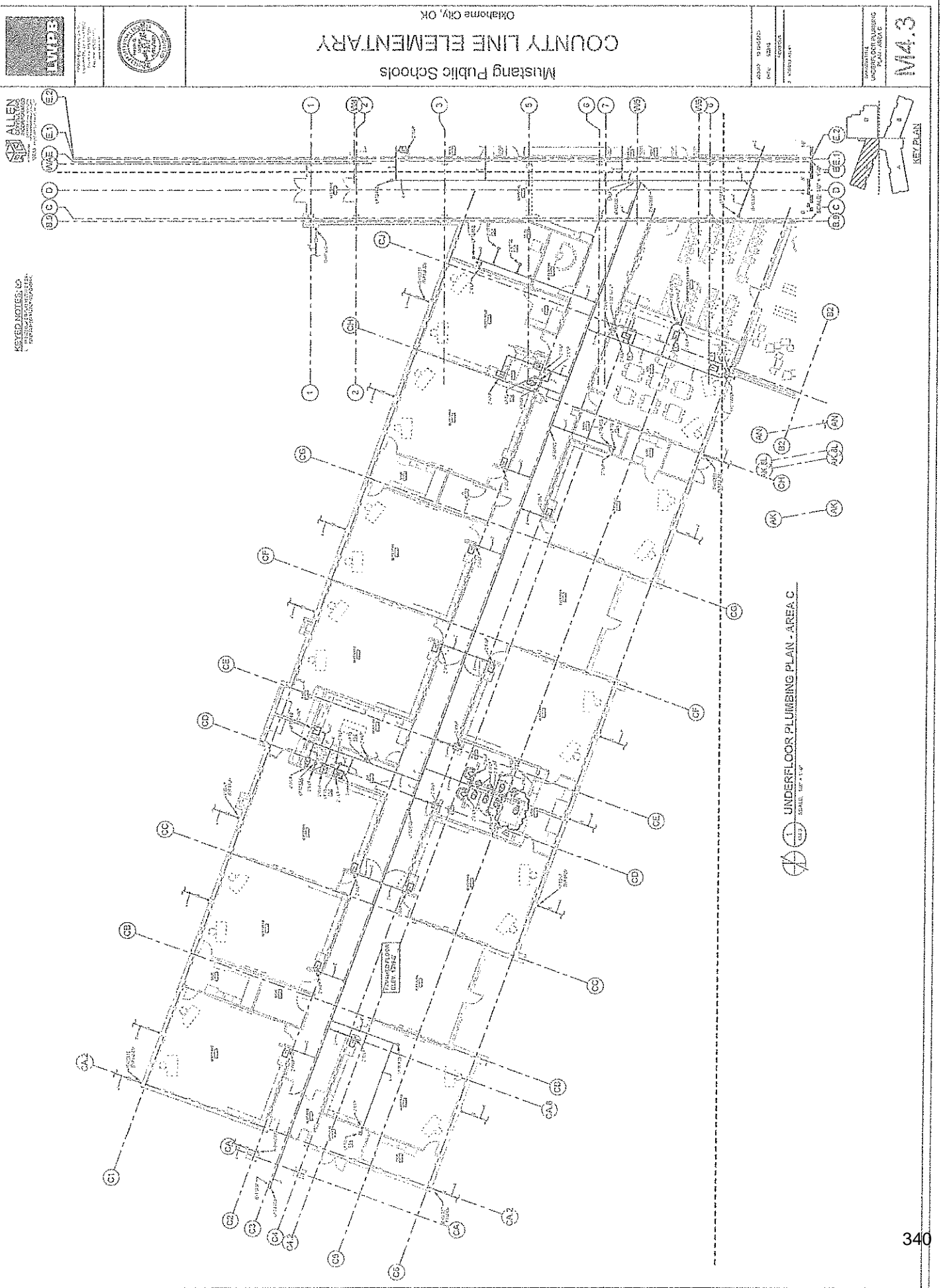

1 UNDERFLOOR PLUMBING PLAN - AREA C
 SCALE: 1/8" = 1'-0"

REVISED NOTES OF
 REVISIONS



100-0013
 12/15/04
 12/15/04
 12/15/04



Mustang Public Schools
 COUNTY LINE ELEMENTARY
 Oklahoma City, OK

DATE	12/15/04
BY	12/15/04
REVISION	12/15/04
PROJECT	100-0013

100-0013
 12/15/04
 12/15/04
 12/15/04

M4.3



Mustang Public Schools
1000 S. MAIN ST.
MUSTANG, OKLAHOMA 73160



MUSTANG PUBLIC SCHOOLS COUNTY LINE ELEMENTARY

Oklahoma City, OK

DATE: 05/15/13
BY: [Signature]
CHECKED: [Signature]
PROJECT: COUNTY LINE ELEMENTARY

PROJECT: COUNTY LINE ELEMENTARY
SHEET: M4.4

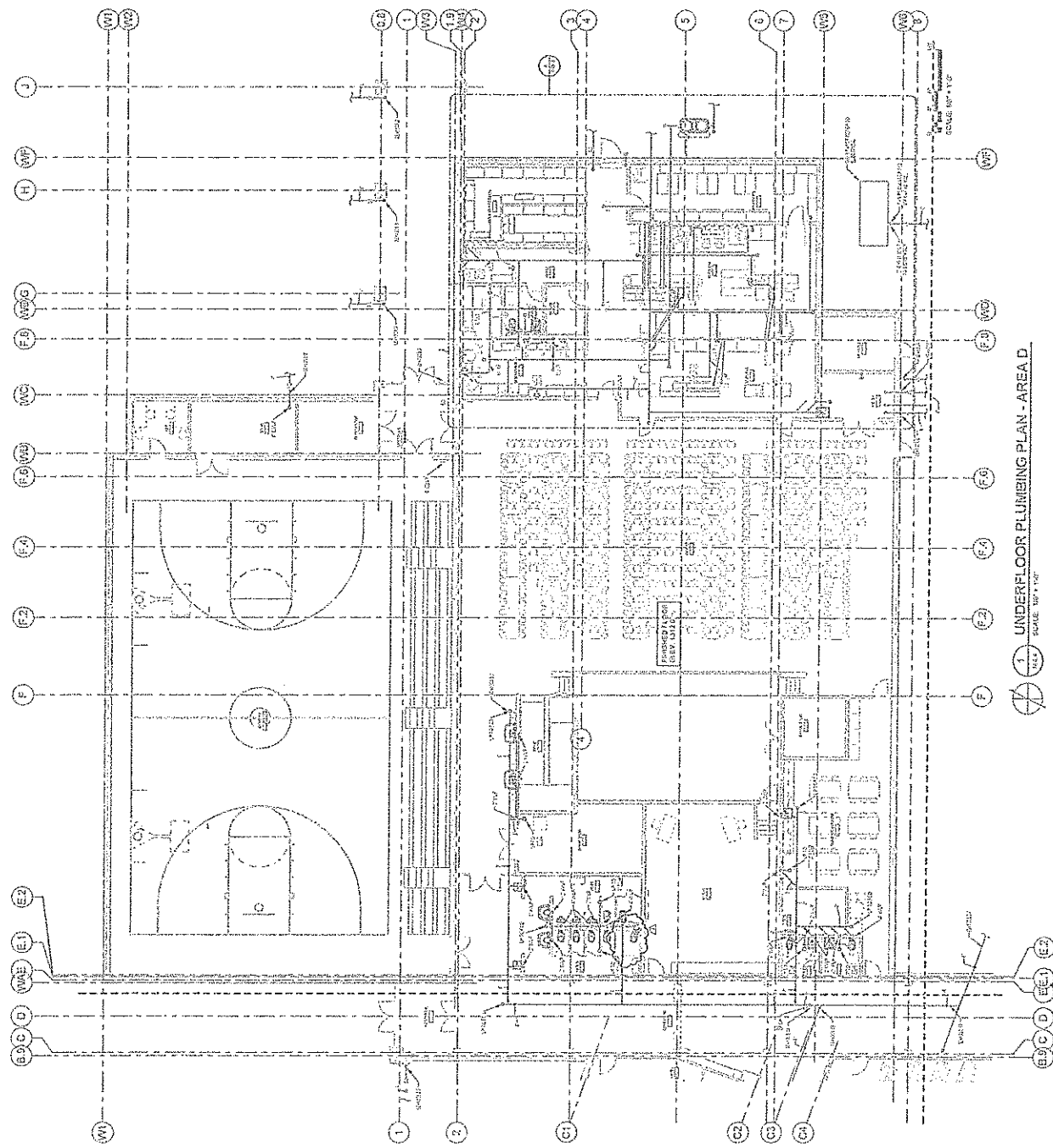
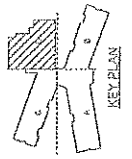

1 UNDERFLOOR PLUMBING PLAN - AREA D
SCALE: 1/8" = 1'-0"

Mustang Public Schools
 COUNTY LINE ELEMENTARY
 Oklahoma City, OK

OWNER: MUSTANG PUBLIC SCHOOLS
 PROJECT: COUNTY LINE ELEMENTARY
 SHEET: M4.5
 DATE: 12/15/13



Professional Engineer
 J. M. MOORE
 License No. 12345
 State of Oklahoma



ALLEN
 ENGINEERING &
 CONSTRUCTION, INC.
 1000 N. W. 10th St., Suite 100
 Oklahoma City, OK 73106
 Phone: (405) 555-1234
 Fax: (405) 555-5678
 Email: info@alleneng.com

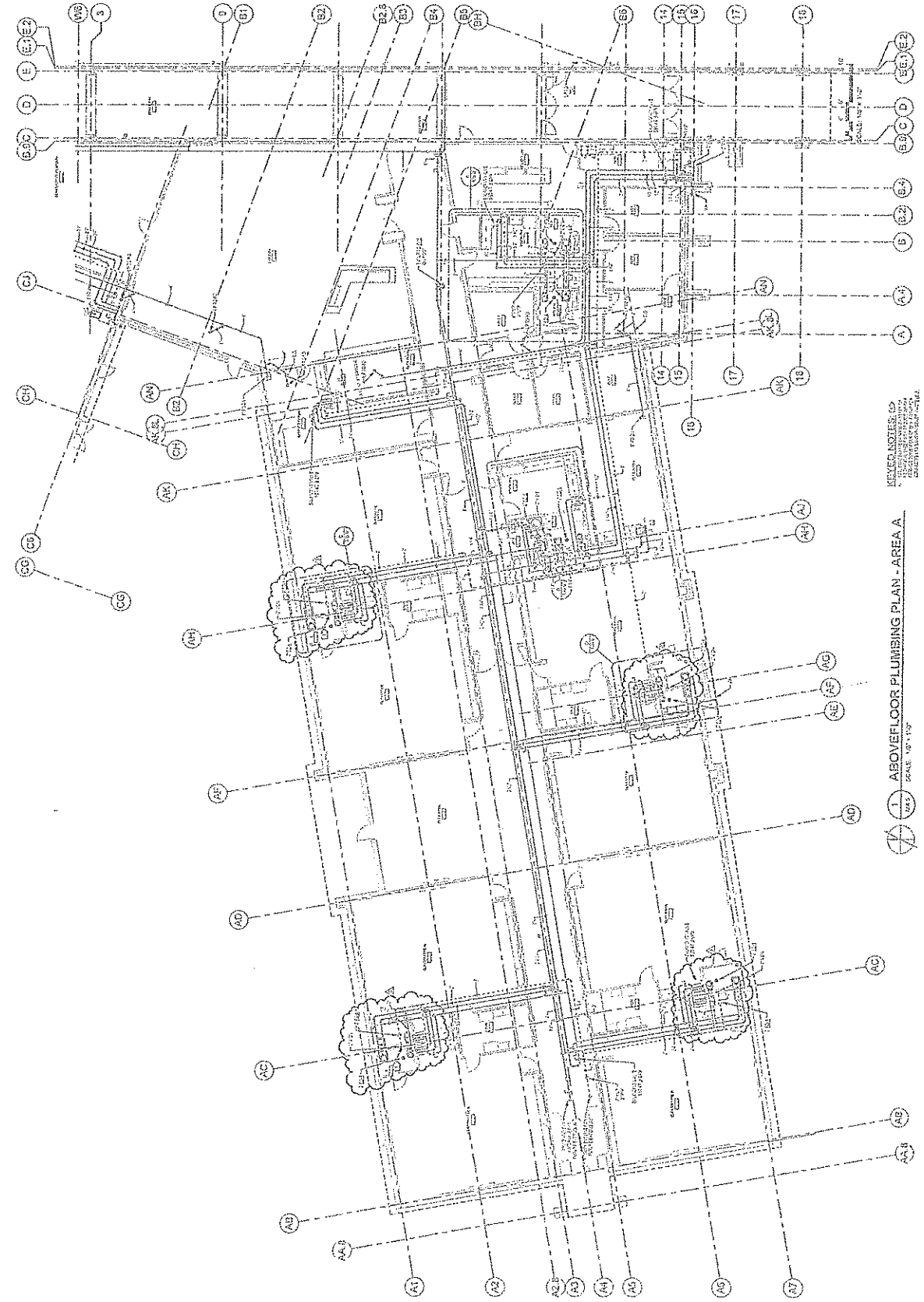

KEY PLAN
 SCALE: 1/8" = 1'-0"

ABOVE FLOOR PLUMBING PLAN - AREA A
 SCALE: 1/8" = 1'-0"

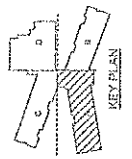

M4.5



Professional Engineer
Mustang Public Schools
Oklahoma City, OK



MUSTANG PUBLIC SCHOOLS COUNTY LINE ELEMENTARY

Oklahoma City, OK

AREA: 10,000 SQ. FT.
DATE: 10/18/11
PROJECT: MUSTANG PUBLIC SCHOOLS
COUNTY LINE ELEMENTARY

SCALE: 1/4" = 1'-0"

M4.6

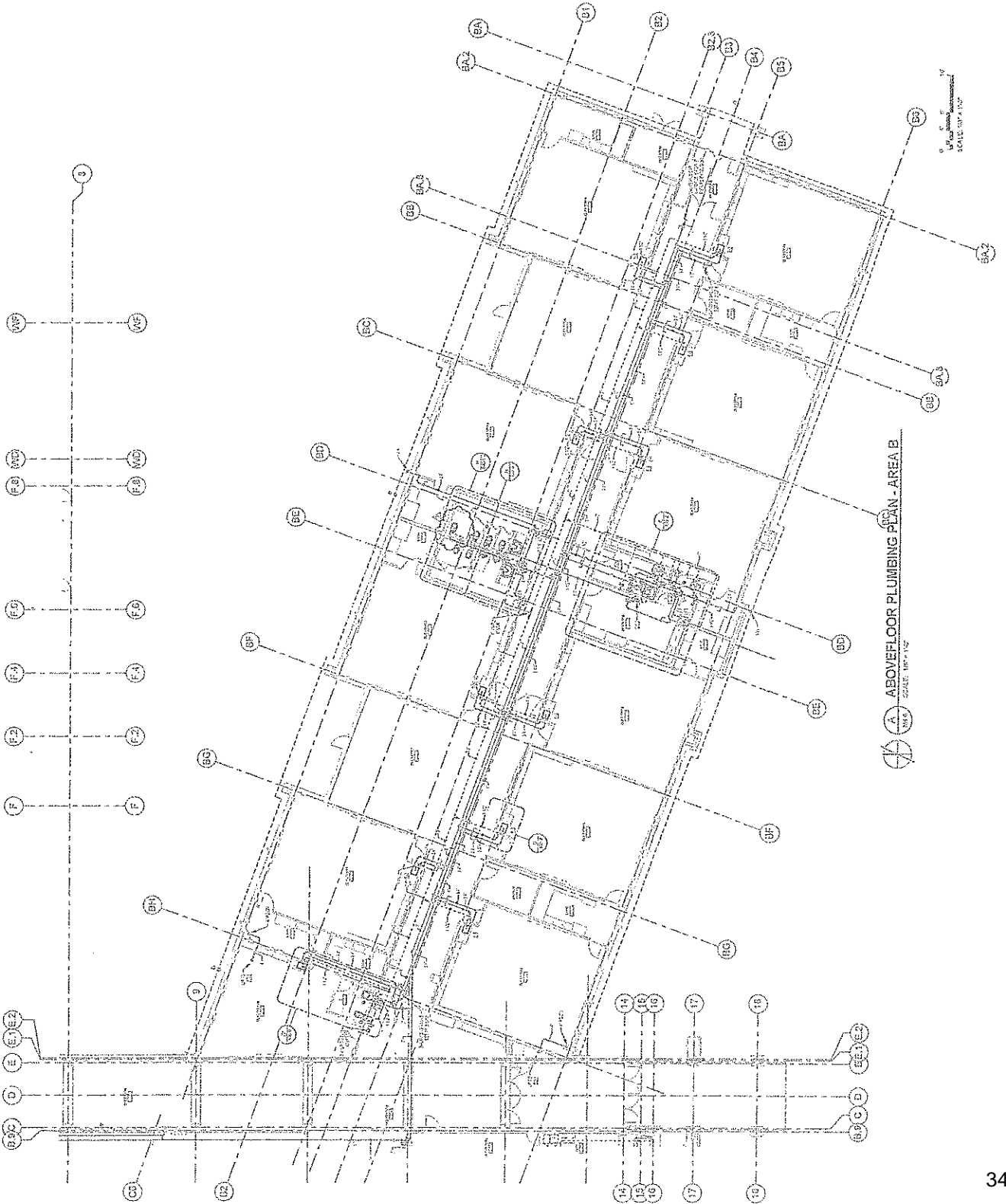
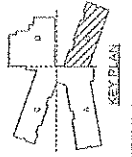

ABOVE FLOOR PLUMBING PLAN - AREA B
SCALE: 1/4" = 1'-0"

DATE: 10/18/11
PROJECT: MUSTANG PUBLIC SCHOOLS
COUNTY LINE ELEMENTARY



Mustang Public Schools
COUNTY LINE ELEMENTARY
Oklahoma City, OK

PROJECT NUMBER: 2013-010427
DATE: 02/27/13
PROJECT: COUNTY LINE ELEMENTARY PLUMBING PLAN AREA C
DRAWN BY: J. ALLEN

PROJECT: COUNTY LINE ELEMENTARY PLUMBING PLAN AREA C
DATE: 02/27/13
DRAWN BY: J. ALLEN
M4.7

KEY NOTES:
1. REFER TO ALL OTHER PLUMBING PLANS FOR COMPLETE INFORMATION.
2. ALL DIMENSIONS ARE UNLESS OTHERWISE NOTED.
3. ALL WORK SHALL BE IN ACCORDANCE WITH THE 2011 UPC.

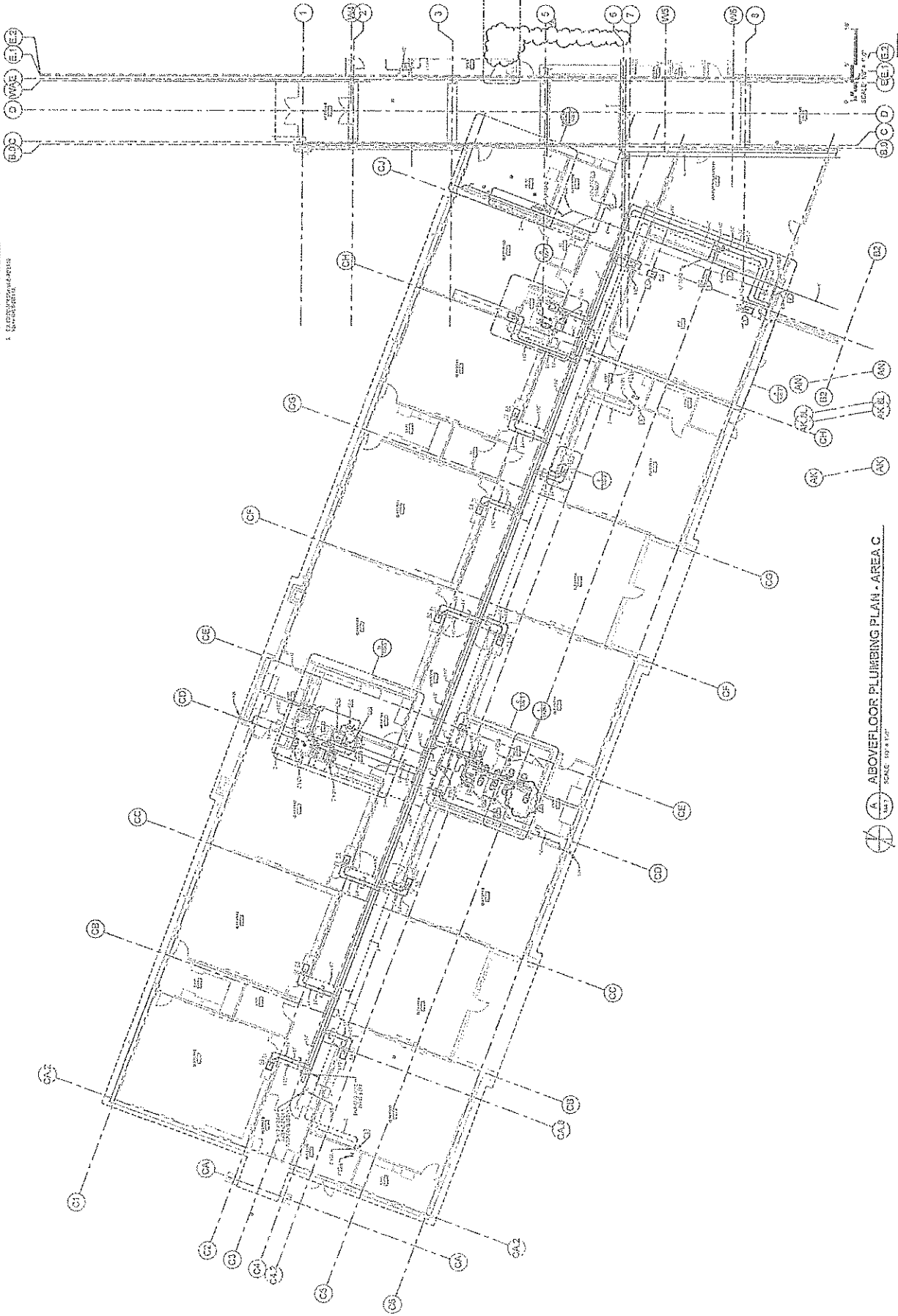

KEY PLAN
A ABOVE FLOOR PLUMBING PLAN - AREA C
SCALE: 1/8" = 1'-0"



Mustang Public Schools
 COUNTY LINE ELEMENTARY
 Oklahoma City, OK

PROJECT: COUNTY LINE ELEMENTARY
 SHEET: M4.8
 DATE: 11/15/11

PROJECT: COUNTY LINE ELEMENTARY
 SHEET: M4.8

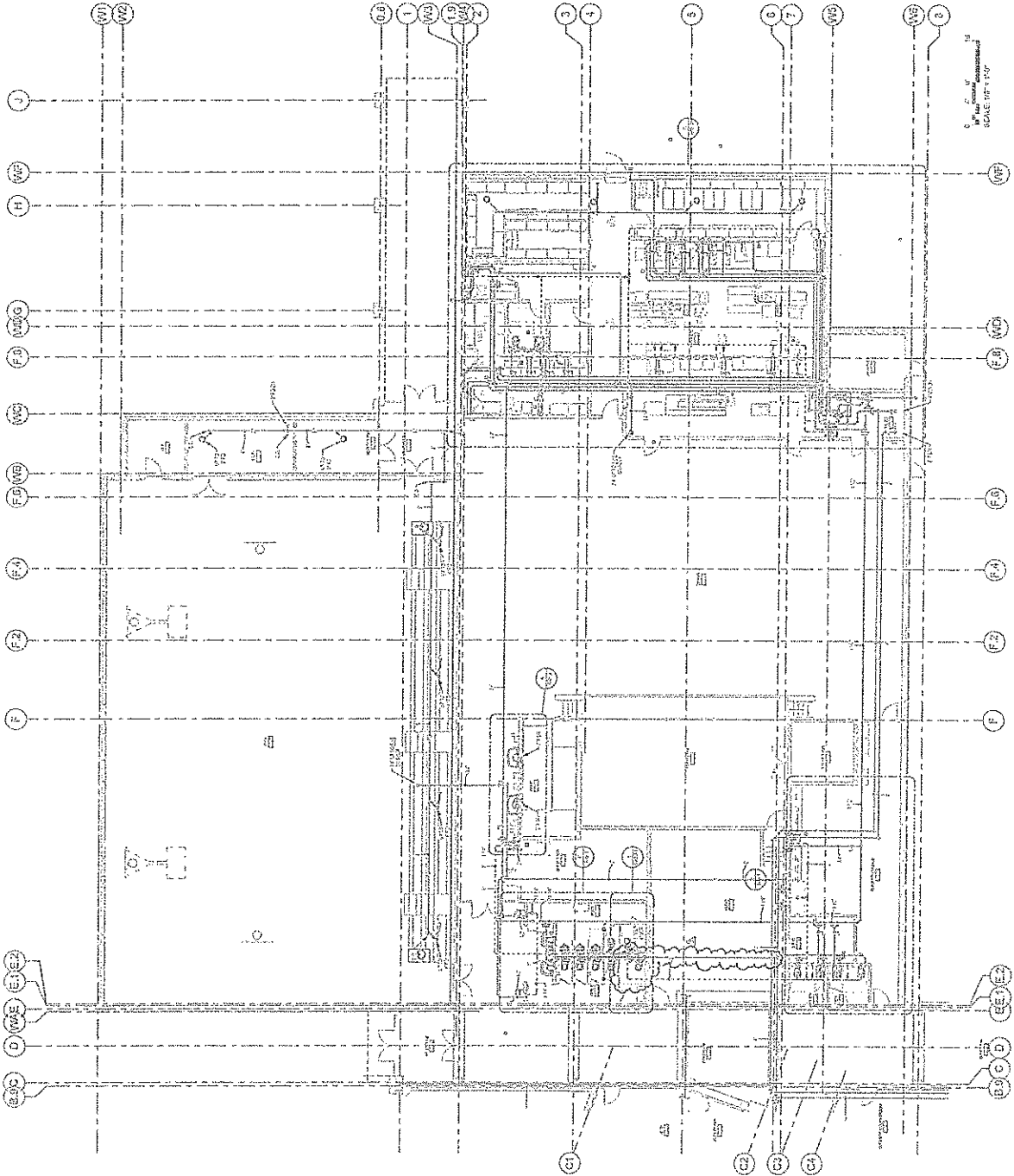
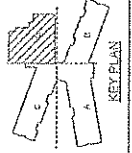

SCALE: 1/8" = 1'-0"

ABOVE FLOOR PLUMBING PLAN - AREA D
 SCALE: 1/8" = 1'-0"



Mustang Public Schools
 COUNTY LINE ELEMENTARY
 Oklahoma City, OK

DATE: 12/15/11
 DRAWN BY: J. HARRIS
 CHECKED BY: J. HARRIS

PROJECT NO. 11-0000
 SHEET NO. M5.0

ALLEN
 ARCHITECTS
 1101 N. W. 10th St.
 Oklahoma City, OK 73102

KEY NOTES:
 1. SEE SHEET M5.1 FOR GENERAL NOTES AND SPECIFICATIONS.
 2. SEE SHEET M5.2 FOR GENERAL NOTES AND SPECIFICATIONS.
 3. SEE SHEET M5.3 FOR GENERAL NOTES AND SPECIFICATIONS.

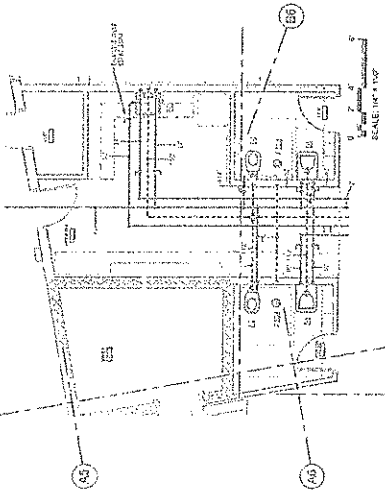

A ENLARGED PLUMBING PLAN - Rm. A108, A109, A110, A111
 SCALE: 1/4" = 1'-0"

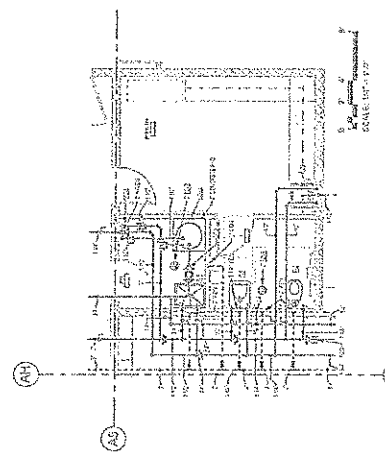

B ENLARGED PLUMBING PLAN - Rm. A121, A122, A123
 SCALE: 1/4" = 1'-0"

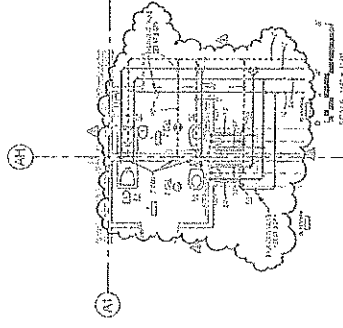

C ENLARGED PLUMBING PLAN - Rm. A124, A125, A127, A128
 SCALE: 1/4" = 1'-0"

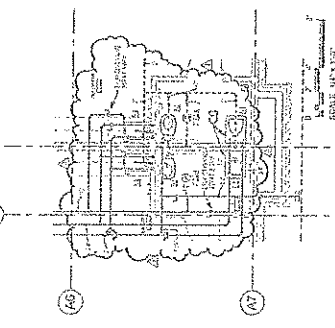

D ENLARGED PLUMBING PLAN - Rm. A129, A132, A133
 SCALE: 1/4" = 1'-0"

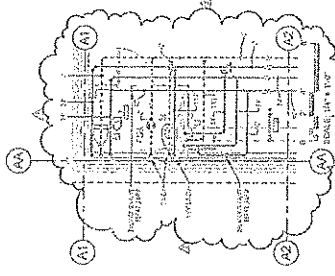

E ENLARGED PLUMBING PLAN - Rm. A148, A149 - ALT.
 SCALE: 1/4" = 1'-0"

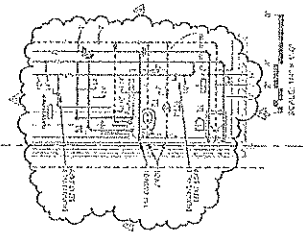

F ENLARGED PLUMBING PLAN - Rm. A145, A146 - ALT.
 SCALE: 1/4" = 1'-0"

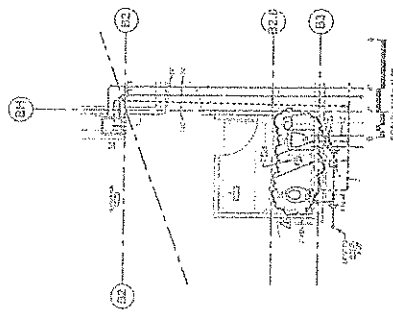

G ENLARGED PLUMBING PLAN - Rm. B100, B101
 SCALE: 1/4" = 1'-0"

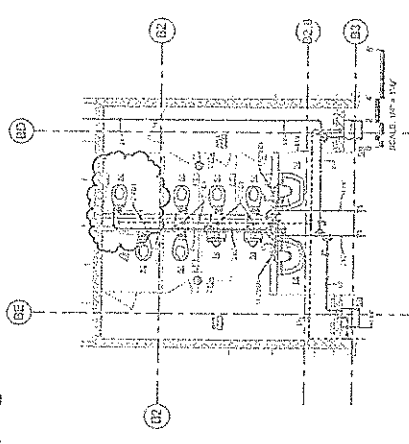

H ENLARGED PLUMBING PLAN - Rm. B113, B114
 SCALE: 1/4" = 1'-0"



Professional Engineer
 License No. 10000
 State of Oklahoma



Mustang Public Schools
 COUNTY LINE ELEMENTARY
 Oklahoma City, OK

ADRIAN WATKINS
 P.E., RAS, RAS
 7/1/2020

PLUMBING
 ENLARGED PLUMBING
 PLAN

M5.1

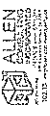

- KEYED NOTES:**
1. ALL WORK SHALL BE IN ACCORDANCE WITH THE 2015 INTERNATIONAL PLUMBING CODE (IPC) AND THE 2015 INTERNATIONAL RESIDENTIAL CODE (IRC).
 2. ALL WORK SHALL BE IN ACCORDANCE WITH THE 2015 INTERNATIONAL MECHANICAL CODE (IMC).
 3. ALL WORK SHALL BE IN ACCORDANCE WITH THE 2015 INTERNATIONAL ELECTRICAL CODE (IEC).
 4. ALL WORK SHALL BE IN ACCORDANCE WITH THE 2015 INTERNATIONAL FIRE AND SAFETY CODE (IFSC).
 5. ALL WORK SHALL BE IN ACCORDANCE WITH THE 2015 INTERNATIONAL BUILDING CODE (IBC).
 6. ALL WORK SHALL BE IN ACCORDANCE WITH THE 2015 INTERNATIONAL ENERGY CONSERVATION CODE (IECC).
 7. ALL WORK SHALL BE IN ACCORDANCE WITH THE 2015 INTERNATIONAL SWEET'S CATALOG (SIC).

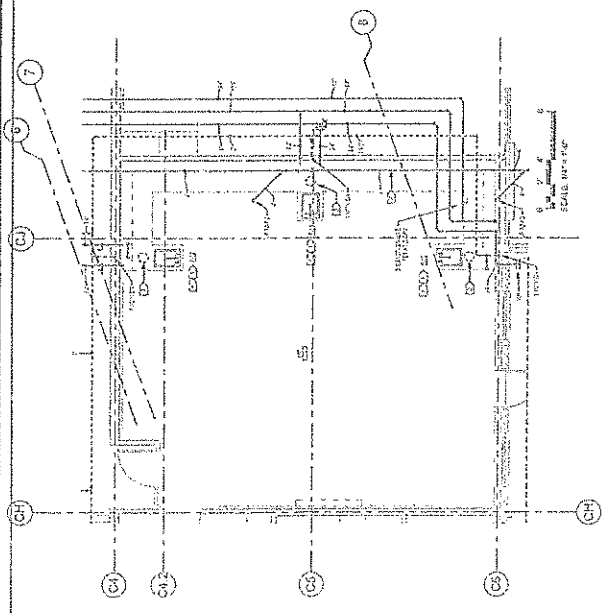

ENLARGED PLUMBING PLAN - RM. C103
 SCALE: 1/4" = 1'-0"

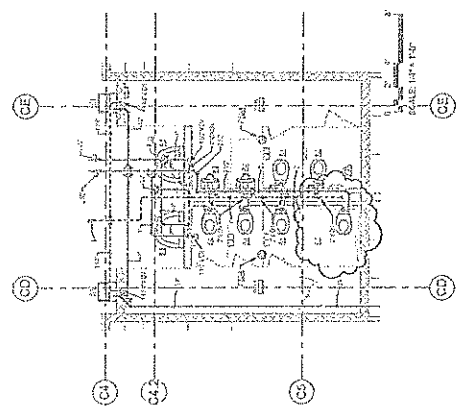

ENLARGED PLUMBING PLAN - RM. C119, C120
 SCALE: 1/4" = 1'-0"

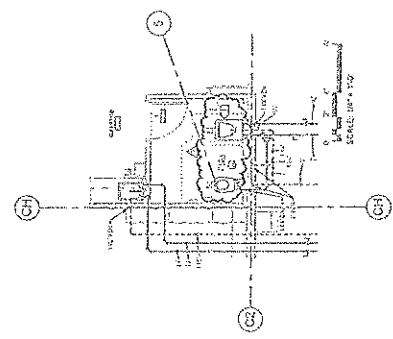

ENLARGED PLUMBING PLAN - RM. C106, C108
 SCALE: 1/4" = 1'-0"

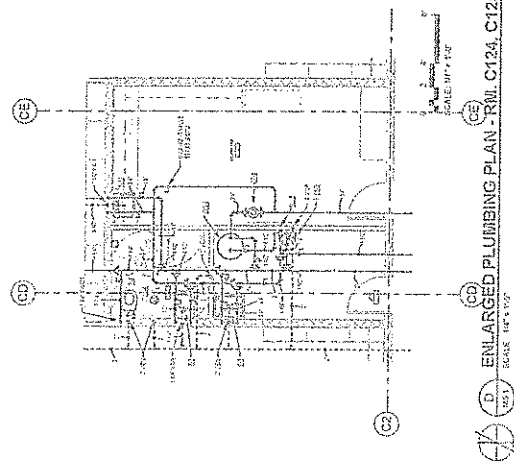

ENLARGED PLUMBING PLAN - RM. C124, C125, C126
 SCALE: 1/4" = 1'-0"

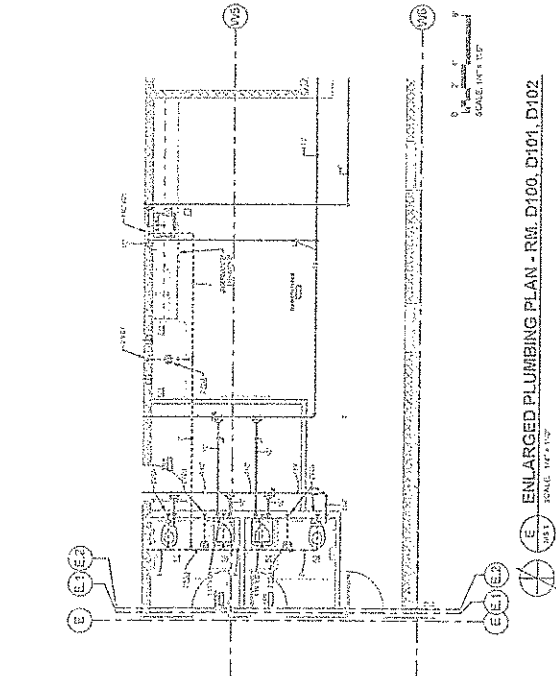

ENLARGED PLUMBING PLAN - RM. D100, D101, D102
 SCALE: 1/4" = 1'-0"

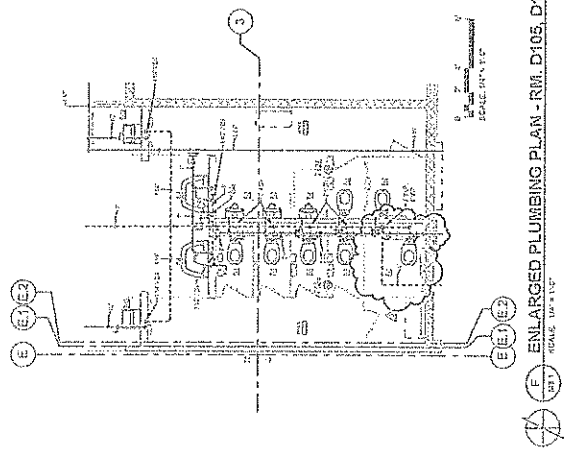

ENLARGED PLUMBING PLAN - RM. D105, D106
 SCALE: 1/4" = 1'-0"

Craig Yadon

From: mweber@orcuttmech.com
Sent: Tuesday, August 13, 2013 7:04 AM
To: Craig Yadon
Subject: [BULK] [FWD: ASI 3 R]

Importance: Low

Here is the revised we talked about

Thank You

Matt Weber
Sr. Estimator/Project Manager
Orcutt Mechanical Contractors, Inc.
5940 NW 38th Street
Oklahoma City, OK 73122
office (405) 787-5888 x206
cell (405) 436-9757
fax (405) 787-5999

----- Original Message -----
Subject: ASI 3 R
From: mweber@orcuttmech.com
Date: Tue, August 13, 2013 7:00 am
To: mweber@orcuttmech.com



5940 NW 38th Street
Oklahoma City, Oklahoma
73122
Phone: (405) 787-5888
Fax: (405) 787-5999

Proposed Change Order

08/07/2013

Timberlake Construction, Inc.
P.O. Box 18297
Oklahoma City, Oklahoma 73154
Phone: 405-840-2521
Fax: 405-840-5469

Attn: Cale Lopp

Project Name: COUNTY LINE ELEM. - 15TH
Project Number: TCI-132
Description: ASI 3 R
Subject: COUNTY LINE ELEM. - 15TH
PCO No.: 01
RE:

Orcutt Mechanical Contractors, Inc. has reviewed the above referenced change(s) and we have determined that our work is impacted as follows:

Net Amount of this Proposed Change: ~~\$10,657.00~~ 10,773
Schedule Impact: 7 Days
Proceeded with proposed work: No
Response due date: 01/01/1900

This proposal is based on the Terms and Conditions as follows:

Description of work:

Addition of wall hung sinks in classroom restrooms as shown. Adjusting layout of rest rooms as shown. Includes underfloor piping vents, carriers fixtures, waterlines and insulation. Addition of waterline shown to main restrooms as shown.

Comments:

If PVC waste and vent lines are allowed please deduct \$1,350.00

SEE PCO# 002 ALSO

If you have any questions, please contact Orcutt Mechanical Contractors, Inc. as soon as possible. This proposal remains in effect for 30 days.

Sincerely,

Matt Weber
Sr. Estimator / Project Manager
Orcutt Mechanical Contractors, Inc.
(405) 787-5888

cc:
Orcutt Mechanical Contractors, Inc., Matt Weber
MW/mw

10,773
~~10,657~~
1,350

9,423
TOTAL \$9,423

BID RECAP SHEET

Company: Enter Company Name Here
 JobName: MUSTANG SCHOOL []
 Bid: Base Bid

8/13/2013
 1:04 PM

(# = from attach wksht)		Materials	Hours	Rate	Price	Total
Material & Lab(see Summary)	#	\$ 3,200	80	\$43.45	\$ 3,476	\$ 6,676
Equipment	#	\$ -	0	\$43.45	\$ -	\$ -
Fixtures	#	\$ 2,100	0	\$43.45	\$ -	\$ 2,100
Specialty	#	\$ -	0	\$43.45	\$ -	\$ -
Other	#	\$ -	0	\$43.45	\$ -	\$ -
G & A - Labor	#		0	varies	\$ -	\$ -
Added on this sheet					\$ -	\$ -
Material & Labor Totals		\$ 5,300	80		\$ 3,476	\$ 8,776
Sales Tax (Y or N)	Y	\$ -	0.00%			\$ -
Materials Total		\$ 5,300		sales tax		\$ 8,776

(# = from attach wksht)

G & A - Equip #	\$	450
G & A - Other #	\$	-
Subs #	\$	-
Sub Total	\$	9,226
Add/Deduct	\$	-
Sub Total	\$	9,226

Overhead	10.00%	\$	923
Profit	5.00%	\$	507
TOTAL		\$	10,656

P&P Bond (Y or N)	Y	\$	117
see bond calculator below			
		\$	10,773

Performance & Payment Bond Calculator			
Total Before Bond:	\$	10,656	
	Brackets	Rate/1000	Bond Amount
1st	100,000	11.00	\$ 117
Next:	400,000	8.00	\$ -
Next:	2,000,000	6.00	\$ -
Next:	2,500,000	6.00	\$ -
Next:	2,500,000	6.00	\$ -
Over:	7,500,000	6.00	\$ -
Total Job Bond			\$ 117
Length of Job		Months	
Premium/month		1.0%	0
Over		Months	
Total Bond This Project			\$ 117



Millwork Proposal

County Line Elementary

8/20/2013

Timberlake Construction
PO Box 18297
Oklahoma City OK 73154

Phone: (405) 840-2521
FAX: (405) 840-5469

Attention: Craig Yadon

SECTIONS:	123204 and 123600
AWI Grade:	Per Specs
Plans Specifications Dated:	7/31/2013
Addenda Included:	ASI #003
Pages Including Cover:	2
CHANGE REQUEST PRICE FOR ASI #003	(\$3,343.00)

Removes 2 full-height open cabinets from storage A126, A131, A137, & A142

Removes 1 full-height open cabinet from storage A153 & A156

EXCLUSIONS: Paint, Stain, and Transparent Finishes. Premium Colors and Finishes. In-wall Blocking and Support Brackets. Glass, Glass Hardware, and Associated Installation. Signage and Lighting. Caulking Millwork to Finished Walls. Payment and Performance Bonds. Any item or room not specified in the attached scope of work. See Scope of Work for details.

EGR Incorporated is a manufacturer of euro style commercial cabinets. EGR adheres strictly to the guidelines outlined by Architectural Woodwork Institute (AWI). The Architectural Woodwork Standards 1st Edition, October 1, 2009, will be used as a reference guide for this Project. This Project has been priced to meet AWI's Grade standard referenced above as per Contract Documents. EGR's Millwork Proposal and Scope of Work will become additions to the Contract. Items not specified in the attached Scope of Work are excluded. EGR will provide detailed Shop Drawings. Installation is detailed in our Proposal. The standards set by AWI (Section 1700) will be followed. Blocking is to be the responsibility of the General Contractor. Following these requirements help to assure a successful Installation. Overtime pay is NOT included in our Proposal. Delays beyond the control of EGR do not warrant overtime.

Respectfully submitted,

Ed Martz

ASI #003 Change Request Breakout

	Price	Percent of Price
Materials	-\$2,498.32	74.7%
Labor	-\$510.38	15.3%
Total Direct Cost	-\$3,008.70	90.0%
Overhead & Profit	-\$334.30	10.0%
Total Change	-\$3,343.00	100%

Bentley Flooring, Inc.

3844 N.W. 8th Street

Oklahoma City, OK 73107

Tel. 405-235-6471 Fax 405-235-1855

Date: August 26, 2013

To: Craig Yadon

Company: Timberlake Construction

From: Ryan Eldridge

Subject: Mustang County Line Elementary

Pages: 1

Section(s): 09300 Tile

ASI#03

Proposal includes labor & materials for the installation of the following:

- Added floor, base and wall tile in (10) restrooms per A2.6.

ASI#03 Total.....~~INCLUDING~~.....~~ALTERNATE~~.....\$ 5,693.00 (excludes tax)
~~ASI#03 Alternate Total.....\$1,138.00~~

Standard Exclusions

The following are excluded unless specifically included above: Epoxy Grout or Mortar, Waterproofing, Crack Isolation Membrane, Mud Bed, Cementitious Backer Units, Mesh Taping, Floor or Wall Prep, Demo, Scraping, Sealing, Waxing, Grinding, Moisture Detection or Correction, Caulking, Post Covering of Surfaces, Temporary Heat, Lighting, Overtime, & After Hours Work. Materials in areas other than those indicated above will result in additional costs.

DISCLAIMER: Bentley Flooring, Inc. cannot assume responsibility for any pre-existing JOBSITE conditions such as soil or slab stability, ground water, hydrostatic pressure, vapor and/or moisture vapor pressure or the presence and condition of vapor barriers, and any unreported substrate contamination. The presence or influence of the above conditions may negatively affect the performance of any flooring system or material installed. The proposal pricing is subject to withdrawal by Bentley Flooring, Inc. if not accepted within thirty (30) days.

Craig Yadon

From: Denise Miller
Sent: Tuesday, August 27, 2013 7:49 AM
To: Craig Yadon
Subject: FW: Additional Mirrors

See below.

Denise Miller
Project Administrator
Timberlake Construction Co., Inc.
P.O. Box 18297
Oklahoma City, OK 73154
405-840-2521 office
405-840-5469 fax
denise@timberlakeconstruction.com
www.timberlakeconstruction.com
|||||||

TIMBERLAKE
Construction

From: Kim Plumlee [<mailto:kplumlee@precisiondoor.com>]
Sent: Monday, August 26, 2013 6:45 PM
To: Denise Miller
Subject: FW: Additional Mirrors

Denise,

Craig was wanting this information last night and I didn't have his email and when I called I got the answering machine. Please make sure he gets this email and please send me his email address.

Kim Plumlee
Project Manager
Precision Door, Inc.
8255 Owasso Expressway
Owasso, OK 74055
kplumlee@precisiondoor.com
918-272-3667 Ext. 8#
Fax 918-274-0140

From: Kim Plumlee [<mailto:kplumlee@precisiondoor.com>]
Sent: Monday, August 26, 2013 5:55 PM
To: 'Cale Lopp'
Subject: Additional Mirrors
Importance: High

Craig,

For 10 ea. additional mirrors it will be \$802. Add to Contract. Let me know if I need to add to approval submittal. If I do need to add I need to know where they will be located.

Thank you

Kim Plumlee

Project Manager

Precision Door, Inc.

8255 Owasso Expressway

Owasso, OK 74055

kplumlee@precisiondoor.com

918-272-3667 Ext. 8#

Fax 918-274-0140

SCOVIL & SIDES HARDWARE COMPANY

P.O. Box 11404; Oklahoma City, OK 73136-0404

Phone: (405) 525-8053 Fax: (405) 521-8246

QUOTE

(8/7/13)

Proposal to: Timberlake Construction
Attn: Craig Yadon
Project: County Line Elem
Location: Mustang, Ok
Architect: LWPB

We propose to furnish on the above referenced project according to plans, specifications and addenda ASI No.003 as prepared by the Architect.

Change openings A151 & A153 to frame type "3" with a sidelight.	\$803.00
Deduct for two only type "1" frames.	<\$262.00
Total add for ASI No. 003	\$541.00

Net, F.O.B. nearest shipping point.

Sales tax not included. Prices are for material only and do not include installation.

TERMS: Net 30 days from date of invoice. Accounts past due shall bear interest at the rate of 1 ½ % per month unless otherwise agreed.

We reserve the right to refuse any order submitted and will not be bound until accepted by our office.

This quotation subject to acceptance within 45 days.

Accepted as Contract

Date _____

By _____

Respectfully Submitted,
Scovil & Sides Hardware Co.

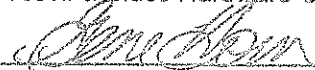
Gene Horn



CHANGE ORDER 1

9401 S. Pole Rd Suite 300
OKC, OK 73160

PROJECT:
County Line Elementary
Mustang Public Schools

CHANGE ORDER NUMBER: 1

TO:
Timberlake Construction
Attn: Craig Yadon

CONTRACT JOB NO.: TCI # 1325

CONTRACT FOR: \$235,480.00

CONTRACT DATE: 7/29/2013

CHANGES IN THIS CONTRACT:

ASI # 3

Add 1/4" Clear Tempered Glass glazed into HM side lites at Doors A151 & A154 - Frame Type 3 (4 pieces)

WORK COVERED BY THIS CHANGE ORDER CANNOT PROCEED UNTIL YOUR WRITTEN ACCEPTANCE IS RECEIVED

The original Contract Sum was		\$ 235,480.00
Net change by previous Change Order #	n/a	\$ -
The Contract Sum prior to this Change Order was		\$ 235,480.00
The Contract Sum will be	Increased	\$ 220.00
The new Contract Sum including this Change Order will be		\$ 235,700.00

BRIAN JOBE
BINSWANGER GLASS

8/27/2013
DATE

ACCEPTED

DATE

TIMBERLAKE CONSTRUCTION COMPANY, INC.

TCI JOB # 1325
County Line Elementary
PROPOSED CHANGE SUMMARY

DATE: 8/27/2013

PROPOSED CHANGE # 005

CHANGE DESCRIPTION: Provide 20 oz Armour Matt XX mesh at all EIFS panels for higher impact resistance to hail.

ADDITIONAL TIME REQUESTED DUE TO THIS CHANGE:

#	ITEM CODE	DESCRIPTION	MATERIAL	LABOR	SUB	EQUIPMENT	TOTALS
1		Deiht Enterprise, INC			\$18,820.00		\$18,820.00
2							\$0.00
3							\$0.00
4							\$0.00
5							\$0.00
6							\$0.00
7							\$0.00
8							\$0.00
9							\$0.00
10							\$0.00
11							\$0.00
12							\$0.00
13							\$0.00
14							\$0.00
15							\$0.00
CATEGORY TOTALS			\$0.00	\$0.00	\$18,820.00	\$0.00	\$18,820.00
0.0000%	SALES TAX	\$0.00	N/A	N/A	\$0.00	\$0.00	\$0.00
38.4400%	LABOR BURDEN	N/A	\$0.00	N/A	N/A	\$0.00	\$0.00
0.8800%	SUB BONDS	N/A	N/A	\$165.62	N/A	\$165.62	\$165.62
SUBTOTALS			\$0.00	\$0.00	\$18,985.62	\$0.00	\$18,985.62
				0.2400% SUB LIABILITY		\$45.57	\$45.57
				0.8300% BONDS		\$157.58	\$157.58
				4.0000% OH&P		\$759.42	\$759.42
				0.3200% Safety		\$60.75	\$60.75
				0.2200% Shop Dray		\$41.77	\$41.77
				0.2500% Cleanup		\$47.46	\$47.46
TOTAL CHANGE ORDER							\$20,098

SPECIAL NOTES AND COMMENTS ABOUT THIS CHANGE:

Special notes and comments about this change: NONE

Additional time requested due to this change: 0 Days

The work described above represents a change in scope and price and will adjust the time to the original contract as indicated. Timberlake Construction is directed to proceed with this work ASAP and the contract sum will be adjusted by change order within 15 day, or as agreed by the owner/contractor.

AUTHORIZING SIGNATURE

OWNER

8-27-13

AUTHORIZING SIGNATURE

TIMBERLAKE CONSTRUCTION

Deihl Enterprises, Inc.

11794 W. Hwy 264
Bentonville, AR 72712
479-248-1067 Phone
479-248-1257 Fax

Change Order 851

August 5, 2013

Timberlake Construction Co., Inc.

P.O. Box 18297
Oklahoma City, OK 73154
405-840-2521 office
405-795-7726 cell
405-840-5469 fax
405-840-2454 direct fax

Attn: Craig Yadon
craigy@timberlakeconstruction.com

Re: County Line Elementary
Edmond, OK

For the following:

Install 15 oz. Armour Mat Mesh with a layer of Standard Mesh on all EIFS.

Extra \$15,910.00 (Fifteen thousand nine hundred ten dollars)

Install 20 oz. Armour Mat XX with a layer of Standard Mesh on all EIFS.

Extra \$18,820.00 (Eighteen thousand eight hundred twenty dollars)

Accepted by

Date

Prices valid for 30 days from the above date unless noted otherwise and are subject to change without notice.

MEMO

To: Sean McDaniel, Superintendent *SM 8-3-13*
From: Jeff Woodard, Director of Bonds/Construction *JW*
Date: August 28, 2013 *8-28-13*
Re: Approval of Right of Way Easements for County Line Elementary

Respectfully request that the Board discuss, consider, and/or act upon approval of the Right of Way Easements for County Line Elementary provided by Legacy Engineering.

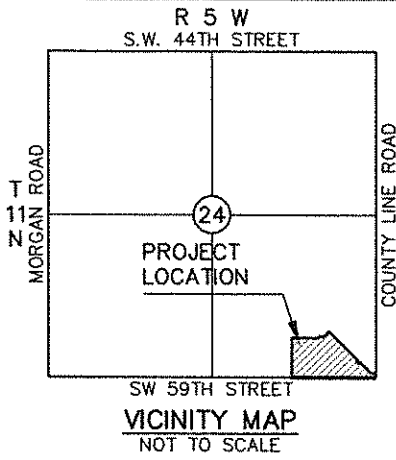

RIGHT-OF-WAY EASEMENT

A tract of land in the SE/4 of Section 24, T11N, R5W of the Indian Meridian, Canadian County, Oklahoma, being more particularly described as follows: Commencing at the Southeast corner of said SE/4; THENCE S 89°24'00" W along the South line of said SE/4, a distance of 1321.92 feet; THENCE N 00°10'36" W, a distance of 33.00 feet to a point on the statutory right-of-way of S.W. 59th Street and said point also being the point of beginning; THENCE continuing N 00°10'36" W, a distance of 17.00 feet; THENCE N 89°24'00" E parallel to the South line of said SE/4, a distance of 1246.88 feet; THENCE N 44°35'43" E, a distance of 25.13 feet to the Southeast corner of Lot 11, Block 2, Silver Leaf West Section 1; THENCE continuing N 44°35'43" E along said Southeast line of said Lot 11, a distance of 10.36 feet to the platted 50 foot West right-of-way line of County Line Road; THENCE S 89°47'26" E, a distance of 17.00 feet to a point on the West statutory right-of-way of County Line Road; THENCE South 00°12'30" East along the said statutory right-of-way, a distance of 41.90 feet to a point on the North statutory right-of-way line of S.W. 59th Street; THENCE S 89°24'00" W along said statutory right-of-way a distance of 1288.90 feet to the point of beginning.

LINE DATA		
NO.	BEARING	DISTANCE
L1	N 00°10'36" W	33.00'
L2	N 00°10'36" W	17.00'
L3	N 44°35'43" E	25.13'
L4	N 44°35'43" E	10.36'
L5	S 89°47'26" E	17.00'
L6	S 00°12'30" E	41.90'

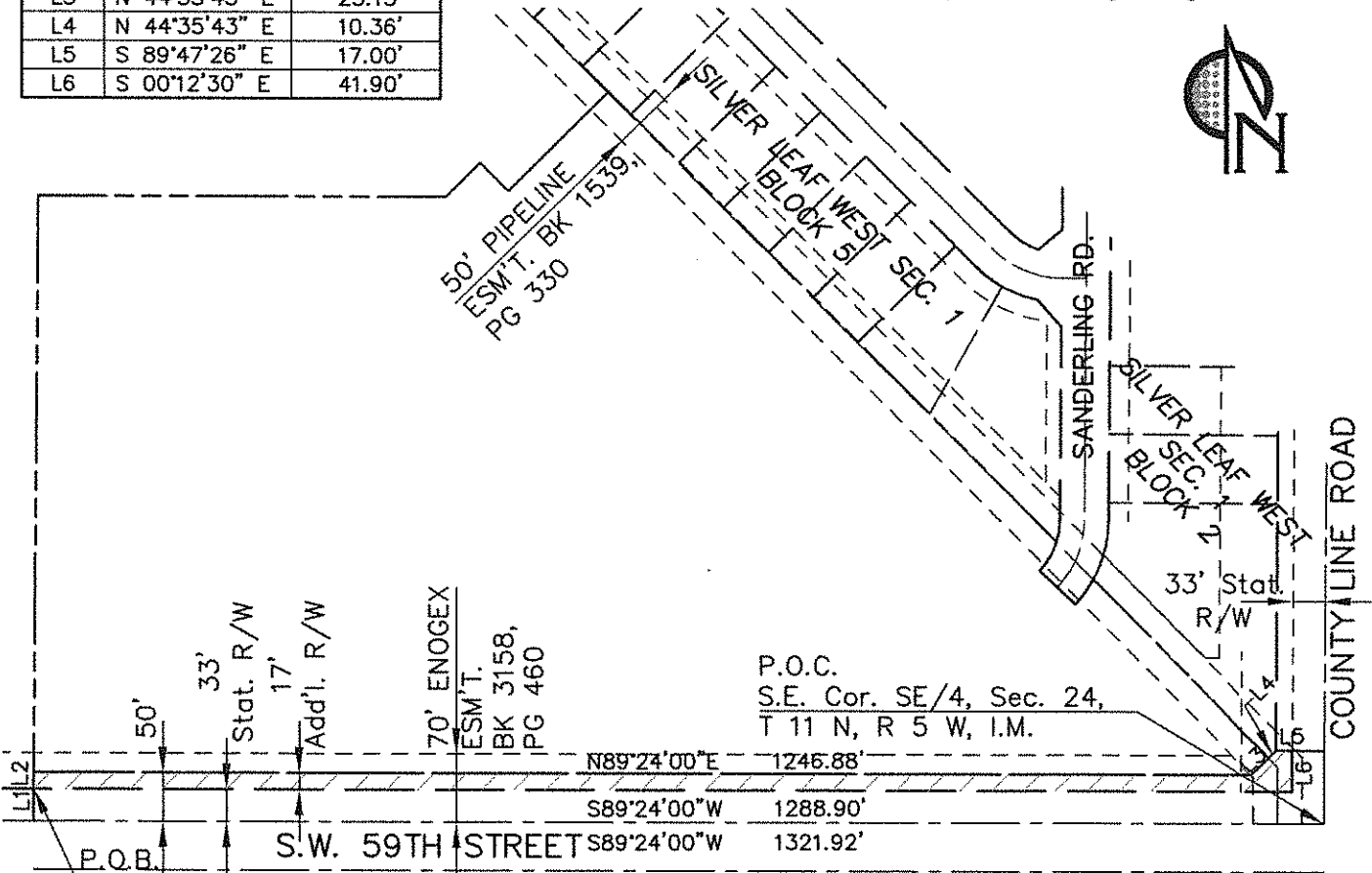

ATTACHMENT A

LEGACY ENGINEERING, INC.
Engineering Construction & Architecture

One N.W. 64th Street, Suite C
Oklahoma City, OK 73116
405/840-0995 info@legacyengr.com

Mustang Public Schools
COUNTY LINE ELEMENTARY
S.W. 59th & COUNTY LINE RD.
Oklahoma City, Oklahoma

RIGHT-OF-WAY	
Drawn By: AMc	Scale: NTS
Checked By: BSB	Date: Aug. 28, 2013
Project No.: A120203	Sheet 1 of 1

R 5 W
S.W. 44TH STREET

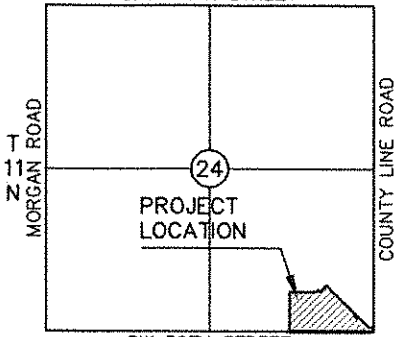

VICINITY MAP
NOT TO SCALE

LINE DATA		
NO.	BEARING	DISTANCE
L1	N 00°36'00" W	50.00'
L2	N 00°36'00" W	49.72'
L3	N 59°46'37" W	70.71'
L4	S 89°57'54" W	20.25'
L5	S 00°02'06" E	20.00'
L6	N 89°57'54" E	25.72'
L7	S 59°46'37" E	71.11'
L8	S 00°36'00" E	65.27'
L9	N 89°24'00" E	15.00'

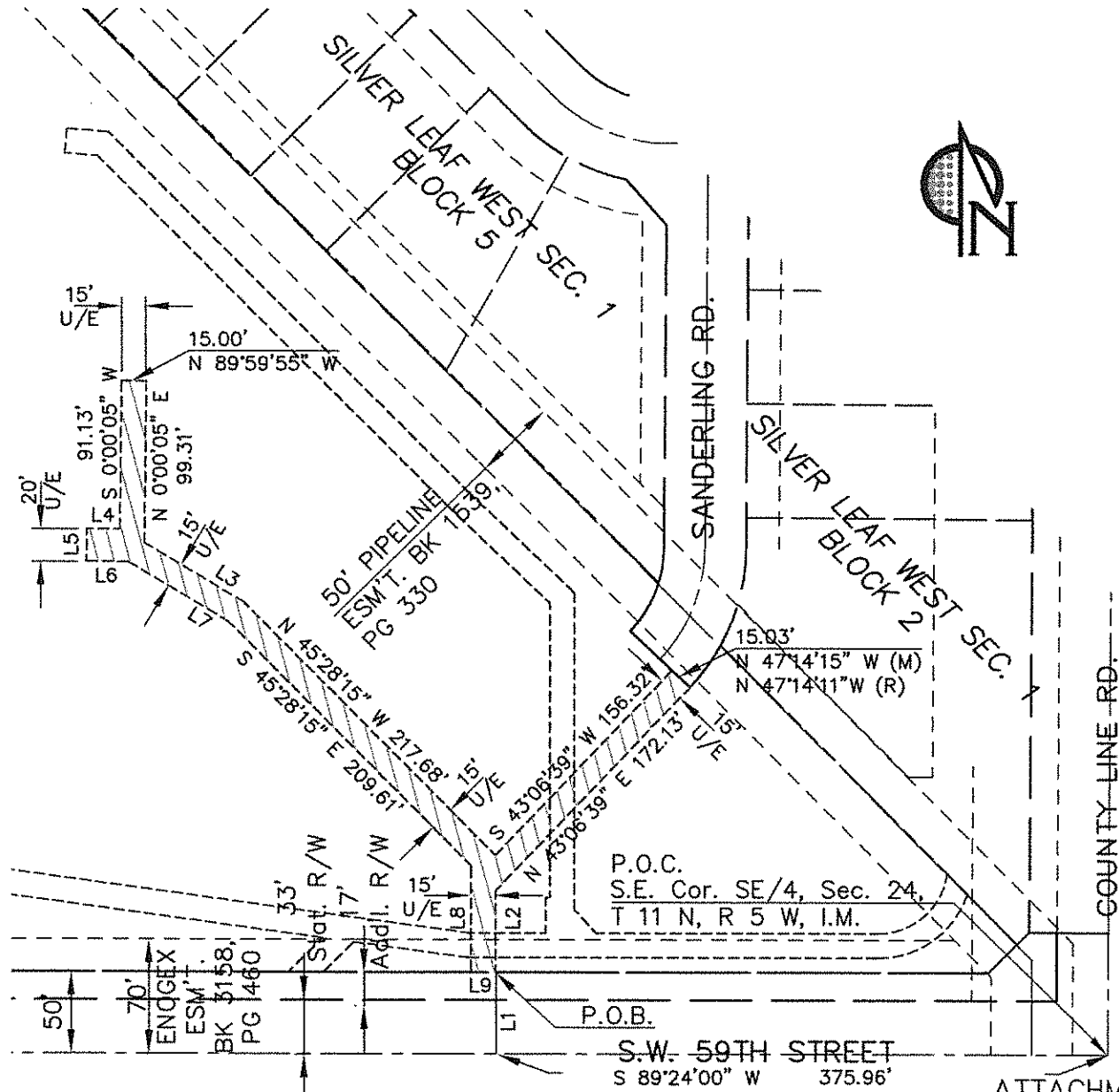

ATTACHMENT A



LEGACY ENGINEERING, INC.
Engineering Technology & Architecture

One N.W. 64th Street, Suite C
Oklahoma City, OK 73116
405/840-0995 info@legacyengr.com

Mustang Public Schools
COUNTY LINE ELEMENTARY
S.W. 59th & COUNTY LINE RD.
Oklahoma City, Oklahoma

WATERLINE EASEMENT 1	
Drawn By: AMc	Scale: NTS
Checked By: BSB	Date: Aug. 28, 2013
Project No.: A120203	Sheet 1 of 2

UTILITY EASEMENT

A utility easement lying in the SE/4 of Section 24, T11N, R5W of the Indian Meridian, Canadian County, Oklahoma and more particularly described as follows: Commencing at the S.E. Corner of said SE/4, thence S 89°24'00" W, along the south line of said SE/4, a distance of 375.96 feet; Thence N 0°36'00" W, a distance of 50 feet to a point on the present right-of-way line and said point being the point of beginning of the following described utility easement:

- Thence continuing N 0°36'00" W, a distance of 49.72 feet;
- Thence N 43°06'39" E, a distance of 172.13 feet to the S.E. Corner of Sanderling Road right-of-way in Silver Leaf West Section 1;
- Thence N 47°14'15" W (Measured) N 47°14'11" W (Plat Record), along said right-of-way, a distance of 15.03 feet;
- Thence S 43°06'39" W, a distance of 156.32 feet;
- Thence N 45°28'15" W, a distance of 217.68 feet;
- Thence N 59°46'37" W, a distance of 70.71 feet;
- Thence N 00°00'05" E, a distance of 99.31 feet;
- Thence N 89°59'55" W, a distance of 15.00 feet;
- Thence S 00°00'05" W, a distance of 91.13 feet;
- Thence S 89°57'54" W, a distance of 20.25 feet;
- Thence S 00°02'06" E, a distance of 20.00 feet;
- Thence N 89°57'54" E, a distance of 25.72 feet;
- Thence S 59°46'37" E, a distance of 71.11 feet;
- Thence S 45°28'15" E, a distance of 209.61 feet;
- Thence S 00°36'00" E, a distance of 65.27 feet to a point on the present right-of-way line;
- Thence N 89°24'00" E, along said right-of-way, a distance of 15 feet to the point of beginning.

ATTACHMENT A

 <p>LEGACY ENGINEERING, INC. Engineering, Technology & Infrastructure One N.W. 64th Street, Suite C Oklahoma City, OK 73116 405/840-0995 info@legacengr.com</p>	<p>Mustang Public Schools COUNTY LINE ELEMENTARY S.W. 59th & COUNTY LINE RD. Oklahoma City, Oklahoma</p>	<p>WATERLINE EASEMENT 1</p>	
		<p>Drawn By: AMc</p>	<p>Scale: NTS</p>
		<p>Checked By: BSB</p>	<p>Date: Aug. 28, 2013</p>
		<p>Project No.: A120203</p>	<p>Sheet 2 of 2</p>

Project No.

PERMANENT EASEMENT
(Representative-Water/Wastewater)

KNOW ALL MEN BY THESE PRESENTS THAT Mustang Public Schools Independent School District #1069 ("grantor") for and in consideration of One Dollar and other good and valuable consideration, receipt of which is hereby acknowledged, does hereby grant and convey unto **THE CITY OF OKLAHOMA CITY**, a municipal corporation, its public trusts, and their successors and assigns (herein collectively referred to as "grantee") a permanent easement over, under, across, through and to the following described property situated in Canadian County, Oklahoma, to wit:
See Attachment "A" (Subject Property)

plus the right of ingress and egress through grantor's property to and from said Subject Property along with all rights, title and interest in and to all land, fixtures, and appurtenances within the boundaries of the Subject Property, incidentally removed during the use of said easement, for the use of grantee for the exclusive purpose of constructing, operating, maintaining, and replacing a water line and other City owned or operated utilities and appurtenances thereto, over, under, through and upon the same. Grantor further covenants and agrees to neither erect a building or other structure nor change the terrain (no excavation or addition of soil) within the described easement without the prior approval of the grantee. Grantor acknowledges the requirement of Oklahoma Statutes Title 63, Section 142.1 et seq., to call OKIE/One Call. Should the grantee abandon the permanent easement and right-of-way for the purposes above stated, then the said easement shall revert to the grantor, its successors and/or assigns.

The grantor hereby agrees that grantor, its heirs, successors, grantees, and assigns, will repair, maintain, and replace paving and facilities on this permanent easement whenever it becomes necessary due to the normal operation, maintenance, and/or repair of the utilities, appurtenances, and facilities. The grantor hereby further agrees that grantor, its heirs, successors, grantees and assigns, will hold the grantee harmless for any damage that should occur as a result of operations, maintenance, and/or repair of such facilities and utilities within the easement.

Dated this _____ day of _____, 20_____.

STATE OF _____)
) ss
COUNTY OF _____)

This instrument was acknowledged before me on this _____ day of _____, 20_____,
by _____ as _____ of Grantor.

My Commission Expires: _____ Notary Public # _____

ACCEPTED by the Council of **THE CITY OF OKLAHOMA CITY** this _____ day of _____, 20_____.

REVIEWED for form and legality.

City Clerk

Assistant Municipal Counselor

R 5 W
S.W. 44TH STREET

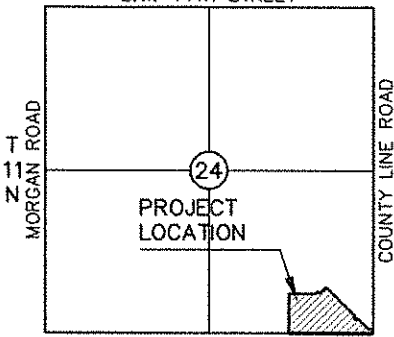

SW 59TH STREET
VICINITY MAP
NOT TO SCALE

LINE DATA		
NO.	BEARING	DISTANCE
L1	N 00°10'36" W	50.00'
L2	N 00°10'36" W	116.66'
L3	N 89°49'24" E	75.20'
L4	N 80°00'52" E	41.27'
L5	N 09°59'08" W	15.00'
L6	S 80°00'52" W	39.98'
L7	S 89°49'24" W	73.91'
L8	N 00°10'36" W	20.50"
L9	S 89°49'24" W	15.00'
L10	S 00°10'36" E	115.56'
L11	N 89°24'00" E	15.00'

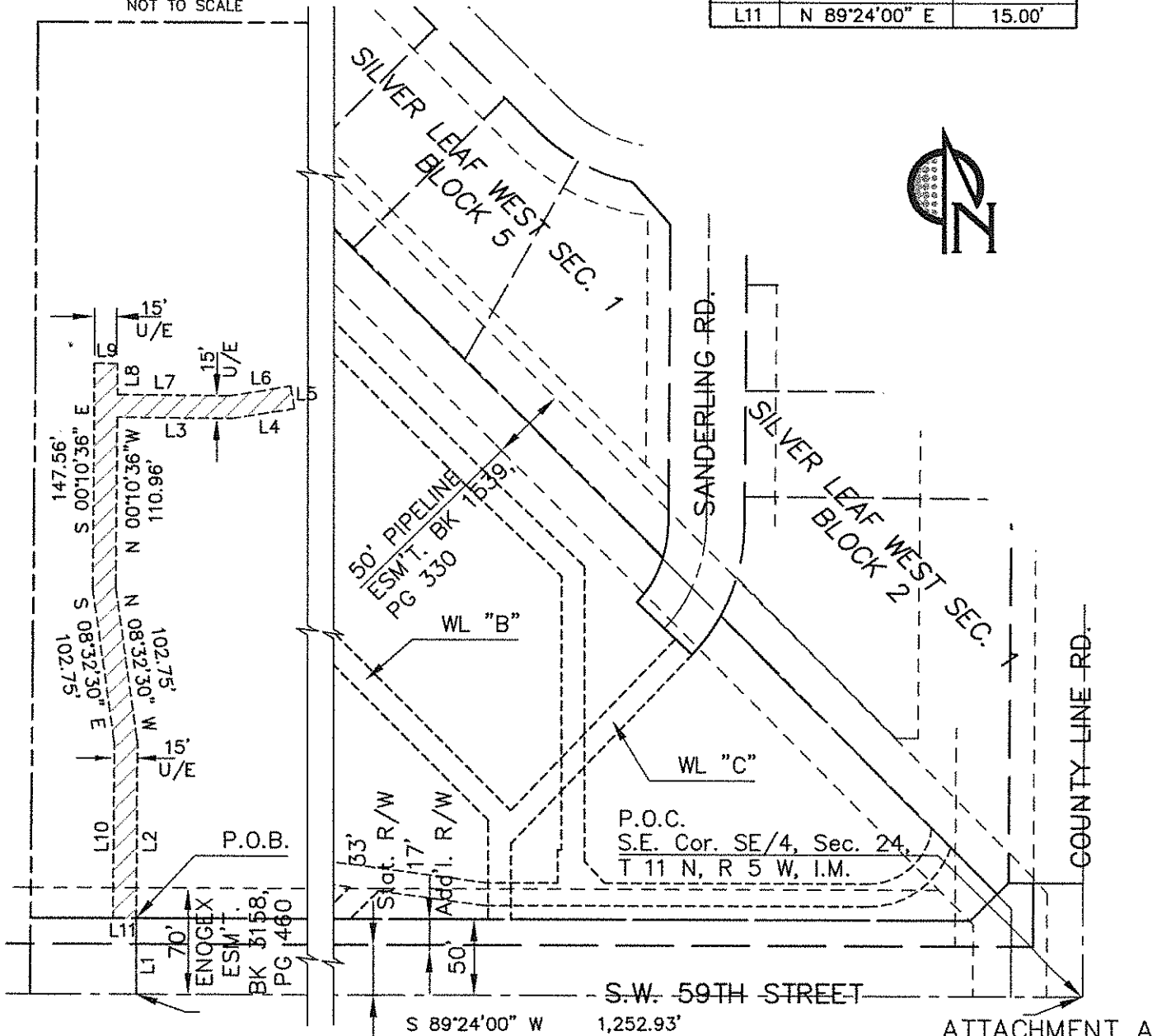

ATTACHMENT A

LEGACY ENGINEERING, INC.
Engineers • Planners • Surveyors

One N.W. 64th Street, Suite C
Oklahoma City, OK 73116
405/840-0995 info@legacyengr.com

Mustang Public Schools
COUNTY LINE ELEMENTARY
S.W. 59th & COUNTY LINE RD.
Oklahoma City, Oklahoma

WATERLINE EASEMENT 2	
Drawn By: AMc	Scale: NTS
Checked By: BSB	Date: Aug. 28, 2013
Project No.: A120203	Sheet 1 of 2

UTILITY EASEMENT

A 15 foot utility easement lying in the SE/4 of Section 24, T11N, R5W of the Indian Meridian, Canadian County, Oklahoma and more particularly described as follows: Commencing at the S.E. Corner of said SE/4, thence S 89°24'00" W, along the south line of said SE/4, a distance of 1,252.93 feet; Thence N 00°10'36" W, a distance of 50 feet to a point on the present right-of-way line and said point being the point of beginning of the following described 15 foot utility easement:

- Thence continuing N 00°10'36" W, a distance of 116.66 feet;
- Thence N 08°32'30" W, a distance of 102.75 feet;
- Thence N 00°10'36" W, a distance of 110.96 feet;
- Thence N 89°49'24" E, a distance of 75.20 feet;
- Thence N 80°00'52" E, a distance of 41.27 feet;
- Thence N 09°59'08" W, a distance of 15.00 feet;
- Thence S 80°00'52" W, a distance of 39.98 feet;
- Thence S 89°49'24" W, a distance of 73.91 feet;
- Thence N 00°10'36" W, a distance of 20.50 feet;
- Thence S 89°49'24" W, a distance of 15.00 feet;
- Thence S 00°10'36" E, a distance of 147.56 feet;
- Thence S 08°32'30" E, a distance of 102.75 feet;
- Thence S 00°10'36" E, a distance of 115.56 feet to a point on the present right-of-way line;
- Thence N 89°24'00" E, along said right-of-way, a distance of 15 feet to the point of beginning.

ATTACHMENT A

 <p>LEGACY ENGINEERING, INC. <small>Engineering, Surveying & Construction</small> One N.W. 64th Street, Suite C Oklahoma City, OK 73116 405/840-0995 info@legocyngr.com</p>	<p>Mustang Public Schools COUNTY LINE ELEMENTARY S.W. 59th & COUNTY LINE RD. Oklahoma City, Oklahoma</p>	<p>WATERLINE EASEMENT 2</p>	
		<p>Drawn By: AMc</p>	<p>Scale: NTS</p>
		<p>Checked By: BSB</p>	<p>Date: Aug. 28, 2013</p>
		<p>Project No.: A120203</p>	<p>Sheet 2 of 2</p>

Project No.

PERMANENT EASEMENT
(Representative-Water/Wastewater)

KNOW ALL MEN BY THESE PRESENTS THAT Mustang Public Schools Independent School District #1069 ("grantor") for and in consideration of One Dollar and other good and valuable consideration, receipt of which is hereby acknowledged, does hereby grant and convey unto **THE CITY OF OKLAHOMA CITY**, a municipal corporation, its public trusts, and their successors and assigns (herein collectively referred to as "grantee") a permanent easement over, under, across, through and to the following described property situated in Canadian County, Oklahoma, to wit:

See Attachment "A" (Subject Property)

plus the right of ingress and egress through grantor's property to and from said Subject Property along with all rights, title and interest in and to all land, fixtures, and appurtenances within the boundaries of the Subject Property, incidentally removed during the use of said easement, for the use of grantee for the exclusive purpose of constructing, operating, maintaining, and replacing a water line and other City owned or operated utilities and appurtenances thereto, over, under, through and upon the same. Grantor further covenants and agrees to neither erect a building or other structure nor change the terrain (no excavation or addition of soil) within the described easement without the prior approval of the grantee. Grantor acknowledges the requirement of Oklahoma Statutes Title 63, Section 142.1 et seq., to call OKIE/One Call. Should the grantee abandon the permanent easement and right-of-way for the purposes above stated, then the said easement shall revert to the grantor, its successors and/or assigns.

The grantor hereby agrees that grantor, its heirs, successors, grantees, and assigns, will repair, maintain, and replace paving and facilities on this permanent easement whenever it becomes necessary due to the normal operation, maintenance, and/or repair of the utilities, appurtenances, and facilities. The grantor hereby further agrees that grantor, its heirs, successors, grantees and assigns, will hold the grantee harmless for any damage that should occur as a result of operations, maintenance, and/or repair of such facilities and utilities within the easement.

Dated this _____ day of _____, 20_____.

STATE OF _____)
) ss
COUNTY OF _____)

This instrument was acknowledged before me on this _____ day of _____, 20_____,
by _____ as _____ of Grantor.

My Commission Expires: _____ Notary Public # _____

ACCEPTED by the Council of **THE CITY OF OKLAHOMA CITY** this _____ day of _____, 20_____.

REVIEWED for form and legality.

City Clerk

Assistant Municipal Counselor

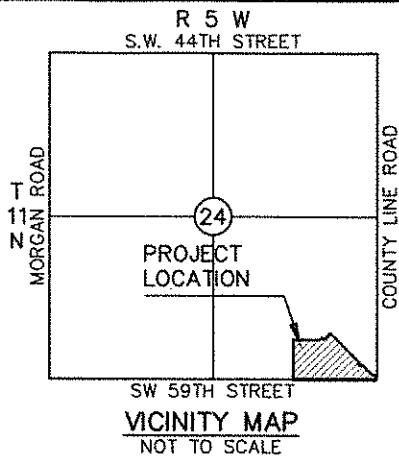

A 15 foot utility easement lying in the SE/4 of Section 24, T11N, R5W of the Indian Meridian, Canadian County, Oklahoma and more particularly described as follows: Commencing at the S.E. Corner of said SE/4, thence S 89°24'00" W, along the south line of said SE/4, a distance of 706.44 feet; Thence N 0°36'00" W, a distance of 50 feet to a point on the present right-of-way and said point being the point of beginning of the following described centerline of a 15 foot utility easement, 7.50 feet on either side of said centerline; Thence continuing N 0°36'00" W, a distance of 14.00 feet to the point of ending.

LINE DATA		
NO.	BEARING	DISTANCE
L1	N 00°36'00" W	50.00'
L2	N 00°36'00" W	14.00'

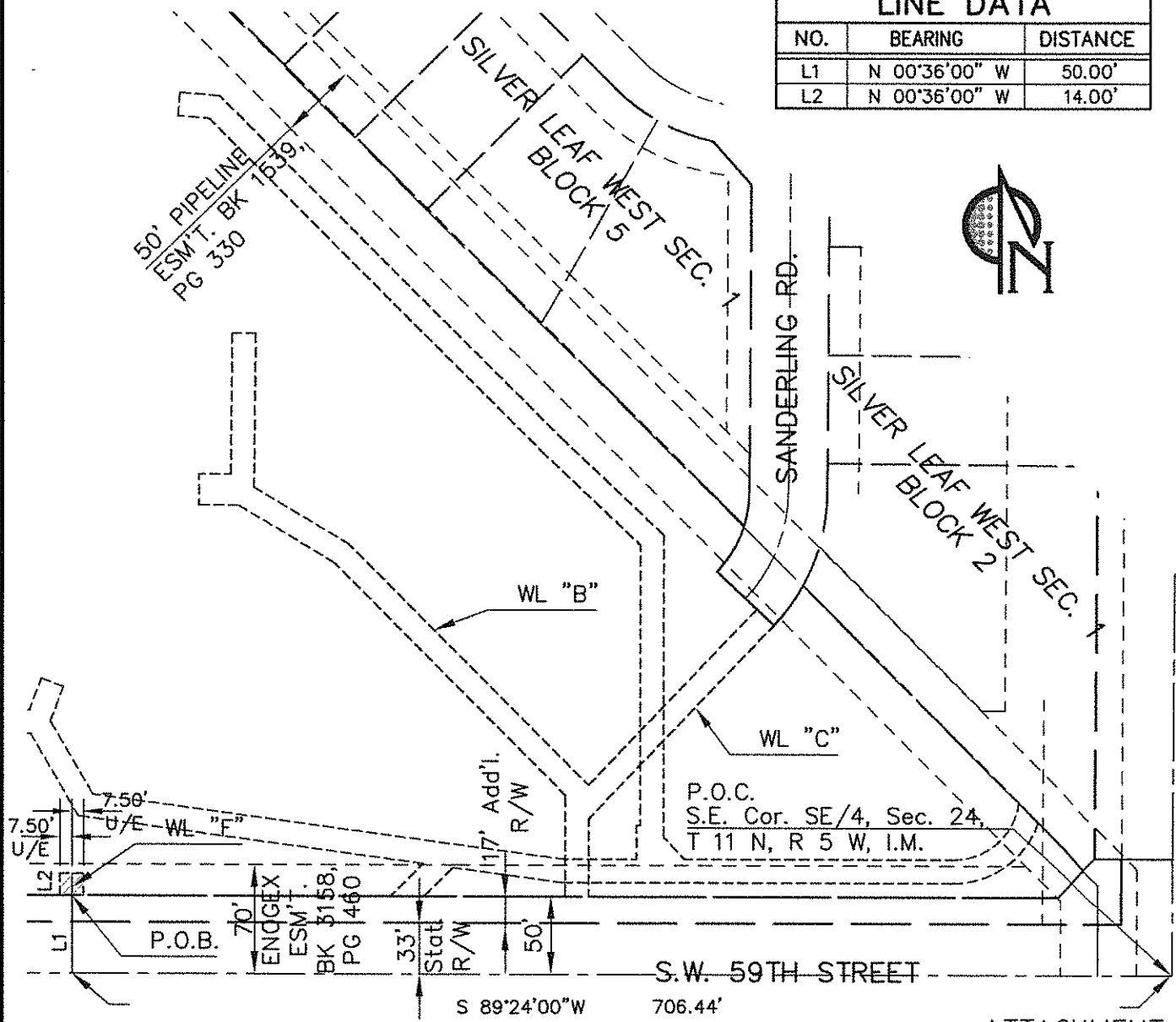

ATTACHMENT A



LEGACY ENGINEERING, INC.
Engineering. Construction. Inspection.

One N.W. 64th Street, Suite C
Oklahoma City, OK 73116
405/840-0995 info@legacyngr.com

Mustang Public Schools
COUNTY LINE ELEMENTARY
S.W. 59th & COUNTY LINE RD.
Oklahoma City, Oklahoma

WATERLINE EASEMENT 3

Drawn By: AMc	Scale: NTS
Checked By: BSB	Date: Aug. 28, 2013
Project No.: A120203	Sheet 1 of 1



BOND ELECTION PROPOSAL

November 12, 2013

Mustang Public Schools
Board of Education
September 9, 2013



Recommended for Bond Proposal

- ROTC Training and Instructional Center
- Expansion of the FFA/Agricultural Education Barn Facility
- Renovation/New Construction of the MHS Baseball Facilities
- Renovation/New Construction of the MHS Softball Facilities
- Transportation
- Technology
- Elementary Playground Equipment
- District Arts Programs
- District Science, Technology, Engineering, & Math (STEM) Initiative
- District Wide Building Maintenance



ROTC Training & Instructional Center

Construction of new ROTC Training & Instructional
Center

Funds: 2013 Bond



EXTERIOR RENDERING



SOUTH ELEVATION



WEST ELEVATION



NORTH ELEVATION



EAST ELEVATION



SITE PLAN



123' - 4"

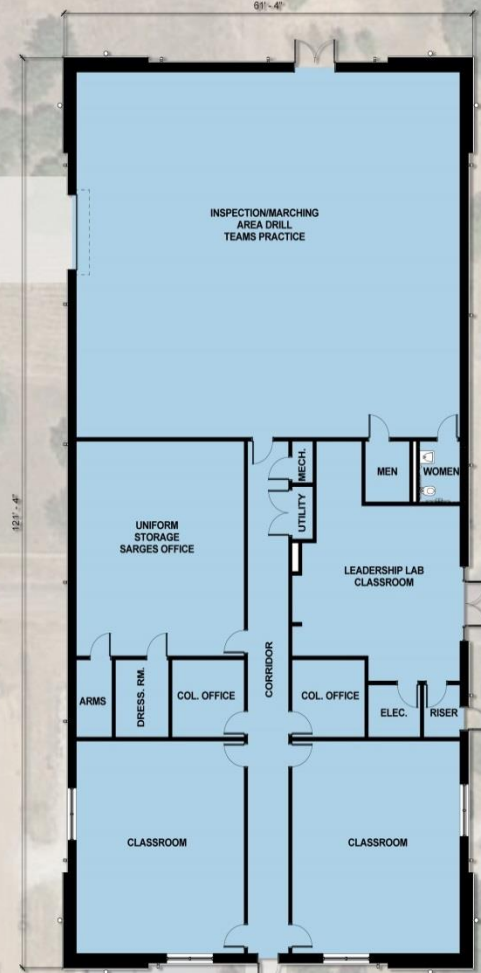

0' 2' 4' 8' 16'

FLOOR PLAN 1/8" = 1' - 0"

ROTC
Mustang, Oklahoma





Agricultural Education Barn Expansion

- New construction of second barn on farm property
- Purchase of fixtures and equipment for use in the AgEd programs

Funds: 2013 Bond



Renovation/New Construction MHS Baseball Facilities

- New Construction of indoor hitting facility
- Renovation and upgrades to existing facility

Funds: 2013 Bond



BRONCO BASEBALL COMPLEX

8-8-18



BRONCO BASEBALL COMPLEX

8-5-19

378

the.stacy.group
ARCHITECTURE

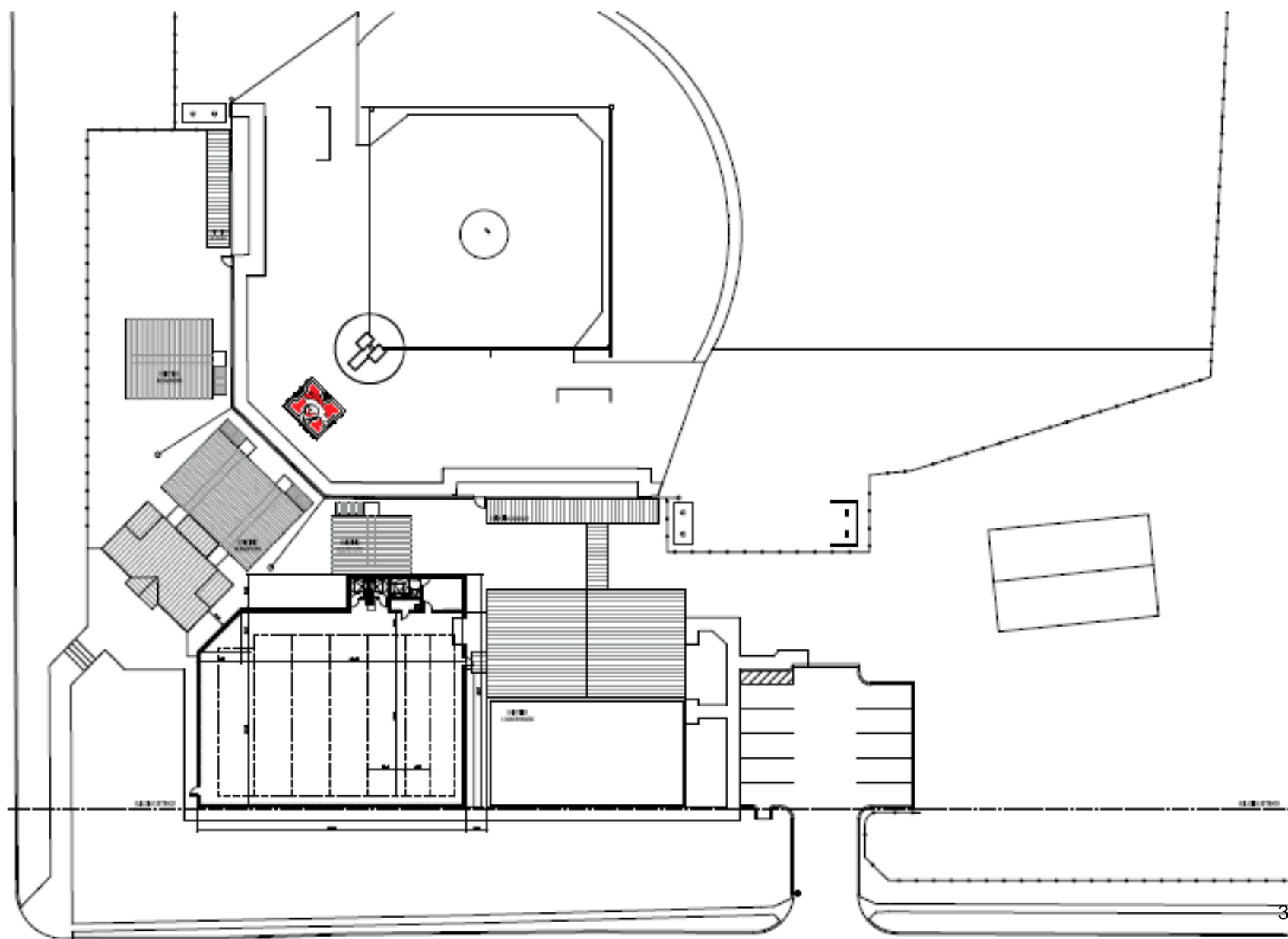



Renovation/New Construction MHS Softball Facilities

- New construction – drop down netting in Health & Wellness Center for hitting
- New construction – facility storage

Funds: 2013 Bond





Elementary Playground Equipment

- Mustang Elementary replacement
- Lakehoma Elementary replacement

Funds: 2013 Bond

AMERICAN
PLAY COMPANY





Technology

- Further implementation of district technology plan to include infrastructure, equipment, and devices

Funds: 2013 Bond



ons.
ing with
switches.





Transportation

- Purchase of 6 new route buses
- Purchase of 2 new handicap buses
- Purchase of 2 new Operations vans

Funds: 2013 Bond





Recommended for Bond Proposal

- ROTC Training and Instructional Center (\$1.4M)
- Expansion of the FFA/Agricultural Education Barn Facility (\$150K)
- Renovation/New Construction of the MHS Baseball Facilities (\$1.325)
- Renovation/New Construction of the MHS Softball Facilities (\$100K)
- Transportation (\$750K)
- Technology (\$350K)
- Elementary Playground Equipment (\$250K)
- District Arts Programs (\$250K)
- District Science, Technology, Engineering, & Math (STEM) Initiative (\$125K)
- District Wide Building Maintenance (\$100K)
- **TOTAL of \$4.8M**



Information

- Resolution
- Proposition 1
- Proposition 2
- Board Q & A
- Reading of the Proposition
- Board action

**Robin M. Howard, MS CCC-SLP
11804 Gwendolyn Lane
Oklahoma City, OK 73131
Professional Services Agreement**

This Agreement is entered into as of August 14, 2013 (the "Effective Date"), between Robin M. Howard, a certified Speech and Language Pathologist and Mustang Public Schools, an Oklahoma Public School ("Customer").

- A. Robin M. Howard, an independent contractor engaged in the business of providing Speech Language Pathology consulting and therapy services.
- B. Customer desires that Robin M. Howard provide certain services to Customer, on the terms and conditions set forth below.

1. SERVICES

Robin M. Howard agrees to provide up to two full school days per week of Speech Pathology services for Mustang Public Schools that meets all guidelines set by the Oklahoma State Department of Education within the Special Education Policies and Procedures Manual.

2. CHARGES; INVOICING AND PAYMENT

Robin M. Howard will invoice Customer monthly. All invoices are due and payable in full within thirty (30) days of Customer's receipt of the invoice. Customer agrees that it shall promptly notify Robin M. Howard in writing of any dispute with any invoice.

3. TERM

3.1 Initial Term

This Agreement will commence on the Effective Date specified above and continue until the end of the scheduled 2013-2014 school year.

3.2 Extension

By giving notice to Robin M. Howard no less than (30) days prior to the expiration date of the initial Term, Robin M. Howard shall have the right to extend the Term for one (1) extension period of up to (1) school year, on the same rates, charges and term and conditions set forth in this Agreement. If the notice period specified above has elapsed and said Customer wants to renew services with Robin M. Howard a new Agreement with new rates, charges and terms and conditions will be enacted.

4. NON-SOLICITATION

Neither party shall solicit employment from any of the other party's employees whose work relates to this Agreement, during the term of this Agreement and for a period of six (6) months after termination of this Agreement, without the prior written consent of the other party.

5. SERVICE RATES

(A) \$65.00 per hour

Robin M. Howard shall not increase such rate levels by more than 5% per year after the initial term of this agreement unless this agreement is extended as outlined in Section 3.2. This includes charges for therapy and IEP paperwork and meetings.

6. MISCELLANEOUS

This Agreement shall be governed by and construed in accordance with the internal laws of the State of Oklahoma. This Agreement may be executed in any number of counterparts, each of which shall be deemed to be an original and all of which together shall be deemed one and the same document. This Agreement may not be amended without the prior written consent of each of the parties hereto. Any amendment to this Agreement or increase in the amount of the Monthly Payment from the amounts specified in Section 2 shall require the approval of Mustang Public Schools. This Agreement may not be assigned or transferred by either party hereto without the consent of the other party hereto. Either party may terminate this Agreement at any time upon sixty days prior written notice without any further liability among the parties hereto, other than the accrued Monthly Amount (including any pro rata amount for a partial month) through the effective time of such termination.

IN WITNESS WHEREOF, the parties have executed this Agreement as of the date first above written.

Robin M. Howard, MS CCC-SLP

Mustang Public Schools

By: Robin Howard MS CCC-SLP

By: _____

Robin Howard
MS CCC-SLP

(name) _____
(title) _____

FINANCIAL ADVISORY SERVICES CONTRACT

Honorable President and Members of the Board of Education
I.S.D. No. 69 of Canadian County, Oklahoma
(Mustang Public Schools)

Ladies and Gentlemen:

In connection with your issue of general obligation bonds for the purpose of financing capital improvements and/or transportation equipment for the Mustang School District (the "School District"), we hereby agree to perform the following services as Financial Advisor/Consultant:

1. We shall prepare a written Financial Analysis based upon the capital improvement and other needs of the School District which shall include a survey of the financial resources of the School District. This document shall also contain an analysis of the existing debt and tax structure of all levels of government involved and compare this analysis to the projected debt. On the basis of information thus developed, we shall devise a financing program to fund the proposed maturities, the estimated interest rate and cost on the proposed bonds, the resulting overall amount of projected annual debt service and tax requirements, and the relationship of these items to existing corresponding projected items of the School District and other related levels of government.
2. We shall provide the following services relating to a bond election:
 - A. Provide the School District with information concerning the most advisable dates for holding an election to approve such issuance;
 - B. Provide the necessary Resolution to call for the election;
 - C. Provide for filing the necessary documentation with the County Election Board;
 - D. Assist in providing printed ballots for such election;
 - E. Arrange for proper legal notices to be published at the appropriate times regarding the notice of such election;
 - F. Appear at public meetings informing the public as to the use of bond proceeds and the effect on ad valorem taxes;
 - G. Assist in the formation of informational brochures discussing the items concerning the election such as taxes and use of proceeds;
 - H. Provide the County Election Board with the appropriate material to canvass the election returns; and
 - I. Assist in the analysis of and provide the School District with election results.
3. Upon approval by the voters of the School District, we shall undertake the following tasks:
 - A. We shall advise the Board of Education of current bond market conditions, forthcoming bond issues, and other general information and economic data that might normally be expected to influence interest rates or bidding conditions so that the date for the sale of the bonds may be set at a time which, in our opinion, would be favorable to the School District.
 - B. We shall assist the School District, if necessary, in the identification, evaluation, and negotiations with prospective paying agents, registrars and transfer agents.

- C . We shall prepare an Official Notice of Sale, that establishes the specifications for bidding; i.e. bond maturity and interest coupon arrangements, interest rate limitations, and other pertinent details.
 - D. We shall also prepare a Preliminary Official Statement that describes the Bonds offered, including complete information as to the security for the Bonds, the School District and other pertinent details.
 - E . We shall prepare a uniform Bid Form which would prevent deviation by any bidders when any such deviation would be costly to the issuing body.
 - F . If desirable, we shall submit to the national rating services or credit enhancement providers, an application necessary to obtain a rating or enhancement on the Bonds. If such service(s) are determined to be necessary for the most effective marketing of the bonds, we shall assist the School District with the following:
 - 1. Provide financial, economic and demographic information to such organizations for their review;
 - 2. Coordinate and negotiate with the rating agencies to obtain the highest possible rating for the Bonds.
 - G. We shall prepare the necessary Resolution to set the date, time and place for the sale of the Bonds.
 - H . We shall be present at the sale of bonds to aid the Board of Education in the tabulation and comparison of bids. We shall also advise the members of the Board of Education as to the bond market conditions at the time of the sale and the advisability of accepting or rejecting the bids submitted.
 - I. We shall prepare the necessary Resolution to authorize the issuance of the Bonds.
 - J. We shall prepare a final Official Statement that describes the Bonds offered, including complete information as to the security for the Bonds, the School District and other pertinent details for use by the successful bidder of the Bonds.
 - K. Assuming a favorable interest rate is received and accepted by the School District, we shall then proceed to take all steps necessary to expedite the preparation of all other documentation necessary to achieve delivery of the Bonds, including delivery of the Transcript of Proceedings to the Attorney General's Office.
- 4 . We shall advise the Board of Education and Administration on the investment of bond proceeds that would, in our opinion, allow the School District to benefit the most from the investment of said proceeds.
 - 5 . We shall advise School District officials as to any pending legislation in the Oklahoma Legislature and the United States Congress which may have an effect upon the School District's proposed and existing indebtedness.
 - 6 . For the above services, you agree to pay us the following:

\$18,000 per series of bonds issued

The above fees are payable only upon a successful election and subsequent receipt of proceeds from the bonds. However, if your election is held and fails, and another election is called for the issuance of bonds within one year from this date, you hereby agree to employ us under the terms of this contract.

In addition to the above fees, you agree to pay or reimburse us for our payment of the following expenses:

1. All Election Board expenses
 2. Legal Publication fees
 3. Secretary of State filing fees
 4. Bond printing
 5. Official Statement Printing & Distribution
 6. Credit Rating Agency Fees
 7. Overnight courier service charges associated with distribution of bond material
7. Either party may terminate this Agreement by giving not less than 30 days prior written notice to the other specifying the effecting date of such termination. If the School District exercises its option to terminate this Agreement, it agrees to reimburse BOSC, Inc., for any of the enumerated expenses advanced by it pursuant to paragraph 6 above and to pay BOSC, Inc., for its services rendered prior to such termination in a mutually acceptable amount to be negotiated in good faith between the parties. In addition, it is acknowledged by the parties that the School District has entered into this Agreement with the understanding that the services to be provided under this Agreement will be provided by Chris Cochran.
8. Neither party to this Agreement shall assign its interests in this Agreement without the specific written prior approval of the other party.

Respectfully submitted,
BOSC, Inc.

Chris Cochran

In a session legally assembled on the 9th day of September, 2013, the above offer was duly considered and approved and accepted. Witness our official hands this 9th day of September, 2013.

(SEAL)

ATTEST: _____
Clerk

President

BID TAB SHEET
60 Acres at 44th and Czech Hall Rd.
FRIDAY, AUGUST 23, 2013 AT 2:00PM

COMPANY NAME	AMOUNT	PHONE #
Gary Owens Const.	\$ 501,000 ⁰⁰	
WP Land	\$ 726,001 ⁰⁰	

\$ 8,350⁰⁰ per acre

\$ 12,100 per acre

**APPLICATION FOR FUNDING
OCMAPS PROGRAM FOR SUBURBAN SCHOOL
IMPROVEMENTS**

Purchase Property for HS Event Center
Project Title

Mustang High School Event Center
Name of School Building/Facility

921 S. Snyder, Mustang, OK 73064
Address/Location of School Building/Facility

328
Number of Oklahoma City Resident Students Enrolled at Facility

Jeff Woodard
Project Contact

906 S. Heights Dr., Mustang, OK 73064
Address

405-376-7342 / 405-376-7901
Phone/Fax

woodardj@mustangps.org
Email

October 1, 2013
Estimated Project Start Date

October 1, 2014
Estimated Project Completion Date

BOARD OF EDUCATION APPROVAL

The above referenced project has been approved by the Board of Education, _____ School District, on this _____ day of _____, 20____.

By: _____
President, Board of Education

APPLICATION SUBMITTAL

**OCMAPS Trust Secretary
c/o City Clerk's Office
200 N. Walker, 2nd Floor
Oklahoma City, OK 73102**

ATTEST

Secretary, OCMAPS Trust

ATTEST

City Clerk

REVIEWED FOR FORM AND LEGALITY:

School District _____
Original Amended
City Project No. _____

\$ 325,000
Total Project Cost Estimate

\$ 325,000
OCMAPS Funding Requested

N/A
Source of Funds, If Request Is Less Than Total Project Cost

The undersigned Architect, Engineer or qualified professional certifies the attached, itemized Cost Estimate is a reasonable amount to complete the public school project.

By: Jeff Woodard
Subscribed and sworn to before me this 22nd day of August, 2013.

Notary Public ASHLI R. MILLER
State of Oklahoma
Comm. Expiration/Comm. #: 7-27-17 Commission # 09005848 Expires 07/17/17

BONDED INDEBTEDNESS

As of this date the School District's percentage of voter-authorized bonded indebtedness is 83.9%. This percentage is equal to or greater than the bonded indebtedness limitation of 50 % and therefore complies with the requirements of the August 28, 2001 Memorandum of Understanding, Section 3, I., and any amendments.

By: _____
President, Board of Education

Subscribed and sworn to before me this _____ day of _____, 20____.

Notary Public _____

Comm. Expiration/Comm. #: _____

APPROVAL

Chairman, OCMAPS Trust / Date

CONCURRENCE

Mayor, The City of Oklahoma City / Date

Assistant Municipal Counselor

DESCRIPTION OF THE PROJECT: (USE ADDITIONAL PAGES IF NEEDED.)

The Mustang Public School district is requesting OCMAPS funds to purchase property for a new HS Event Center. The district continues steady growth in student population. This facility will allow students and student athletes room for additional Physical Education classes, Locker rooms, and a Gymnasium. Total seating capacity would be approximately 2,800.

**BID TAB SHEET
TRANSPORTATION - BUS BID
THURSDAY, AUGUST 29, 2013**

COMPANY NAME	AMOUNT	DELIVERY DATE	DAYS TO COMPLETE
ROSS TRANSPORTATION	Spec. Ed w/Lift \$94,926	FEB. 2014	
ROSS TRANSPORTATION	77 pass. \$83,901.00	FEB. 2014	
MIDWEST BUS SALES	NO BID		
MIDWEST BUS SALES	NO BID		
ROBERTS BUS CENTER	Spec. Ed w/Lift \$101,734.00	60-90 days	
ROBERTS BUS CENTER	77 pass. \$91,049.00	60-90 days	

Mustang School District No.I-069, Canadian County, Oklahoma
Summary of Estimate of Needs

GENERAL FUND APPROPRIATIONS - 2013-14	
General Fund Cash Fund Balance July 1, 2013	\$4,573,861.63
ESTIMATED MISCELLANEOUS REVENUE FOR 2013-14	
1200 Tuition & Fees	0.00
1300 Earnings on Investments	13,000.00
1400 Rental, Disposals and Commissions	0.00
1500 Reimbursements	0.00
1600 Other Local Sources of Revenue	0.00
1700 Child Nutrition Programs	0.00
1800 Athletics	0.00
2100 County 4 Mill Ad Valorem Tax	1,475,000.00
2200 County Apportionment (Mortgage Tax)	375,000.00
2300 Resale of Property Fund Distribution	0.00
2910 Other Intermediate Sources of Revenue	0.00
3110 Gross Production Tax	850,000.00
3120 Motor Vehicle Collections	2,222,000.00
3130 Rural Electric Cooperative Tax	120,000.00
3140 State School Land Earnings	1,200,000.00
3150 Vehicle Tax Stamps	0.00
3160 Farm Implement Tax Stamps	0.00
3170 Trailers and Mobile Homes	0.00
3190 Other Dedicated Revenue	0.00
3210 Foundation and Salary Incentive Aid	24,269,215.00
3220 Mid-Term Adjustment For Attendance	0.00
3230 Teacher Consultant Stipend	0.00
3250 Flexible Benefit Allowance	3,942,129.75
3300 State Aid - Competitive Grants - Categorical	0.00
3400 State - Categorical	527,413.00
3500 Special Programs	0.00
3600 Other State Sources of Revenue	0.00
3700 Child Nutrition Program	0.00
3800 State Vocational Programs - Multi-Source	121,120.00
4100 Grants-In-Aid Direct From The Federal Government	150,000.00
4200 Disadvantage Students	928,252.97
4300 Individuals With Disabilities	1,685,769.96
4400 No Child Left Behind	0.00
4500 Grants-In-Aid Passed Through Other State/Intermediate Sources	0.00
4600 Other Federal Sources Passed Through State Dept Of Education	0.00
4700 Child Nutrition Programs	0.00
4800 Federal Vocational Education	0.00
5100 Return of Assets	0.00
Total Miscellaneous Revenue	37,878,900.68
Sub-Total	42,452,762.31
35 Mill Ad Valorem Tax (Net)	12,799,294.02
GRAND TOTAL 2013-14 GENERAL FUND APPROPRIATIONS	55,252,056.33

GENERAL FUND APPROPRIATIONS 2013-14	
Current Expense	\$55,252,056.33
Interest	0.00
Pro rata share of County Assessor's Budget by County Excise Board	0.00
GRAND TOTAL 2013-14 GENERAL FUND APPROPRIATIONS	\$55,252,056.33

BUILDING FUND APPROPRIATIONS 2013-14	
Cash Fund Balance July 1, 2013	\$1,095,615.22
5 Mill Levy (Net)	1,829,421.08
Miscellaneous Revenue	0.00
Total Building Fund	\$2,925,036.30

BUILDING FUND APPROPRIATIONS 2013-14	
Current Expense	\$2,925,036.30
Interest	0.00
Pro rata share of County Assessor's Budget by County Excise Board	0.00
GRAND TOTAL 2013-14 BUILDING FUND APPROPRIATIONS	\$2,925,036.30

CHILD NUTRITION FUND APPROPRIATIONS 2013-14	
Cash Fund Balance July 1, 2013	\$593,026.61
Miscellaneous Revenue	3,582,286.64
Total Child Nutrition Fund	\$4,175,313.25

CHILD NUTRITION FUND APPROPRIATIONS 2013-14	
Current Expense	\$4,175,313.25
Interest	0.00
GRAND TOTAL 2013-14 CHILD NUTRITION FUND APPROPRIATIONS	\$4,175,313.25

COOP FUND APPROPRIATIONS 2013-14	
Cash Fund Balance July 1, 2013	\$0.00
Miscellaneous Revenue	0.00
Total Coop Fund	\$0.00

COOP FUND APPROPRIATIONS 2013-14	
Current Expense	\$0.00
Interest	0.00
GRAND TOTAL 2013-14 COOP FUND APPROPRIATIONS	\$0.00

2013 VALUATIONS	\$387,248,085
2012 VALUATIONS	364,348,316
INCREASE (DECREASE)	\$22,899,769

AVAILABLE BONDING CAPACITY ASOF JULY 1, 2013	
10% of Net Valuations	\$38,724,808.50
Less: Bonds Outstanding	33,170,000.00
NET AVAILABLE BONDING CAPACITY	\$5,554,808.50

Publication Sheet - Board of Education
 Financial Statement of the Various Funds for the Fiscal Year Ending June 30, 2013, And
 Estimate of Needs for Fiscal Year Ending June 30, 2014, of Mustang Public Schools
 School District No. 1-069, Canadian County, Oklahoma

STATEMENT OF FINANCIAL CONDITION AS OF JUNE 30, 2013	GENERAL FUND DETAIL	BUILDING FUND DETAIL	CO-OP FUND DETAIL	NUTRITION FUND DETAIL
ASSETS:				
Cash Balance June 30, 2013	\$10,806,122.83	\$1,186,526.33	\$0.00	\$906,692.07
Investments	485,000.00	245,000.00	0.00	0.00
TOTAL ASSETS	\$11,291,122.83	\$1,431,526.33	\$0.00	\$906,692.07
LIABILITIES AND RESERVES:				
Warrants Outstanding	6,291,106.84	139,808.57	0.00	216,500.32
Reserve for Interest on Warrants	0.00	0.00	0.00	0.00
Reserves From Schedule 8	426,154.36	196,102.54	0.00	97,165.14
TOTAL LIABILITIES AND RESERVES	\$6,717,261.20	\$335,911.11	\$0.00	\$313,665.46
CASH FUND BALANCE (Deficit) JUNE 30, 2013	\$4,573,861.63	\$1,095,615.22	\$0.00	\$593,026.61

ESTIMATED NEEDS FOR FISCAL YEAR ENDING JUNE 30, 2014

GENERAL FUND		SINKING FUND BALANCE SHEET	
Current Expense	\$55,252,056.33	1. Cash Balance on Hand June 30, 2013	\$5,471,018.87
Reserve for Int. on Warrants & Revaluation	0.00	2. Legal Investments Properly Maturing	485,000.00
Total Required	\$55,252,056.33	3. Judgments Paid To Recover By Tax Levy	1,142.22
FINANCED:		4. Total Liquid Assets	\$5,957,161.09
Cash Fund Balance	\$4,573,861.63	Deduct Matured Indebtedness:	
Estimated Miscellaneous Revenue	37,878,900.68	5. a. Past-Due Coupons	\$0.00
Total Deductions	\$42,452,762.31	6. b. Interest Accrued Thereon	0.00
Balance to Raise from Ad Valorem Tax	\$12,799,294.02	7. c. Past-Due Bonds	0.00
ESTIMATED MISCELLANEOUS REVENUE:		8. d. Interest Thereon after Last Coupon	0.00
1000 District Sources of Revenue	\$13,000.00	9. e. Fiscal Agency Commissions on Above	0.00
2100 County 4 Mill Ad Valorem Tax	1,475,000.00	10. f. Judgements and Int. Levied for/Unpaid	0.00
2200 County Apportionment (Mortgage Tax)	375,000.00	11. Total Items a. Through .f	\$0.00
2300 Resale of Property Fund Distribution	0.00	12. Balance of Assets Subject to Accrual	\$5,957,161.09
2900 Other Intermediate Sources of Revenue	0.00	Deduct Accrual Reserve if Assets Sufficient:	
3110 Gross Production Tax	850,000.00	13. g. Earned Unmatured Interest	\$33,386.24
3120 Motor Vehicle Collections	2,222,000.00	14. h. Accrual on Final Coupons	0.00
3130 Rural Electric Cooperative Tax	120,000.00	15. i. Accrued on Unmatured Bonds	5,378,500.00
3140 State School Land Earnings	1,200,000.00	16. Total Items g Through i	\$5,411,886.24
3150 Vehicle Tax Stamps	0.00	17. Excess of Assets Over Accrual Reserves (Page 2)	\$545,274.85
3160 Farm Implement Tax Stamps	0.00	SINKING FUND REQUIREMENTS FOR 2013-2014	
3170 Trailers and Mobile Homes	0.00	1. Interest Earnings on Bonds	\$477,246.04
3190 Other Dedicated Revenue	0.00	2. Accrual on Unmatured Bonds	9,214,500.00
3200 State Aid - General Operations	28,211,344.75	3. Annual Accrual on "Prepaid" Judgements	1,142.22
3300 State Aid - Competitive Grants	0.00	4. Annual Accrual on Unpaid Judgments	0.00
3400 State - Categorical	527,413.00	5. Interest on Unpaid Judgements	0.00
3500 Special Programs	0.00	6. Credit to Sch. Dist. No. & No.	0.00
3600 Other State Sources of Revenue	0.00	7. Credit to Sch. Dist. No. & No.	0.00
3700 Child Nutrition Program	0.00	8. Annual Accrual from Exhibit KK	
3800 State Vocational Programs	121,120.00		
4100 Capital Outlay	150,000.00		
4200 Disadvantage Students	928,252.97		
4300 Individuals With Disabilities	1,685,769.96		
4400 Minority	0.00		
4500 Operations	0.00	Total Sinking Fund Requirements	\$9,692,888.27
4600 Other Federal Sources of Revenue	0.00	Deduct:	
4700 Child Nutrition Programs	0.00	1. Excess of Assets over Liabilities	\$545,274.85
4800 Federal Vocational Education	0.00	2. Surplus Building Fund Cash	0.00
5000 Non-Revenue Receipts	0.00	3. Contributions From Other Districts	0.00
Total Estimated Revenue	\$37,878,900.68	Balance To Raise	\$9,147,613.41

Publication Sheet - Board of Education
 Financial Statement of the Various Funds for the Fiscal Year Ending June 30, 2013, And
 Estimate of Needs for Fiscal Year Ending June 30, 2014, of Mustang Public Schools
 School District No. I-069, Canadian County, Oklahoma

** If line 12 is less than line 16 after omitting "h" deduct the following each in turn from line 4, "Total liquid Assets".	SINKING FUND
13d. j. Unmatured Coupons Due Before 4-1-2014	0.00
14d. k. Unmatured Bonds So Due	0.00
15d. l. Whatever Remains is for Exhibit KK Line E.	0.00
16d. Deficit as Shown on Sinking Fund Balance Sheet.	0.00
17d. Less Cash Requirements for Current Fiscal Year in Excess of Cash on Hand (From Line 15d Above).	0.00
18d. Remaining Deficit is for Exhibit KK Line F.	0.00

BUILDING FUND		CO-OP FUND	
Current Expense	\$2,925,036.30	Current Expense	\$0.00
Reserve for Int. on Warrants & Revaluation	0.00	Reserve for Int. on Warrants & Revaluation	0.00
Total Required	\$2,925,036.30	Total Required	\$0.00
FINANCED:		FINANCED:	
Cash Fund Balance	\$1,095,615.22	Cash Fund Balance	\$0.00
Estimated Miscellaneous Revenue	0.00	Estimated Miscellaneous Revenue	0.00
Total Deductions	\$1,095,615.22	Total Deductions	\$0.00
Balance to Raise from Ad Valorem Tax	\$1,829,421.08	Balance	\$0.00

CHILD NUTRITION PROGRAMS FUND	
Current Expense	\$4,175,313.25
Reserve for Int. on Warrants & Revaluation	0.00
Total Required	\$4,175,313.25
FINANCED:	
Cash Fund Balance	\$593,026.61
Estimated Miscellaneous Revenue	3,582,286.64
Total Deductions	\$4,175,313.25
Balance	\$0.00

CERTIFICATE - GOVERNING BOARD

STATE OF OKLAHOMA, COUNTY OF CANADIAN,ss:

We, the undersigned duly elected, qualified and acting officers of the Board of Education of Mustang Public Schools, School District No. I-069, of Said County and State, do hereby certify that at a meeting of the Governing Body of the said District begun at the time provided by law for districts of this class and pursuant to the provisions of 68 O. S. 2001 Sec. 3003, the foregoing statement was prepared and is a true and correct condition of the Financial Affairs of said District as reflected by the records of the District Clerk and Treasurer. We further certify that the foregoing estimate for current expenses for the fiscal year beginning July 1, 2013, and ending June 30, 2014, as shown are reasonably necessary for the proper conduct of the affairs of the said Municipality, that the Estimated Income to be derived from sources other than ad valorem taxation does not exceed the lawfully authorized ratio of the revenue derived from the same sources during the preceding year.

 President of Board of Education

Subscribed and sworn to before me this _____ day of _____, 2013

 Notary Public

SCHEDULE "A"
September 9, 2013

NAME		SITE/ASSIGNMENT		EFFECTIVE
Resignations				
Joule, Dee		Horizon/Cafeteria Assistant		8/15/2013
Prophete, Angela		LE/Crosswalk Attendant		8/30/2013
Lucas, Tacey		Trails/Spec. Ed Teacher Assistant		8/15/2013
Rinehart, Windy		Canyon Ridge/Spec. Ed Teacher Assistant		8/14/2013
Krug, Nancy		MMS/Team Leader - extra duty		8/26/2013
Name	From: Site/Assignment	To: Site/Assignment		Effective
Reassignments				
Brown, Stacy	Admin/Accounts Payable	Admin/Business Facilitator		2013-2014
Jones, Liz	HS/Spec. Ed Teacher Assistant	Canyon Ridge/Spec. Ed Teacher Assistant		2013-2014
Renchen, Shirley	HS/Spec. Ed Teacher Assistant	Canyon Ridge/Spec. Ed Teacher Assistant		2013-2014
Treschitta, Debra	HS/Spec. Ed Teacher Assistant	Canyon Ridge/Spec. Ed Teacher Assistant		2013-2014
Madison, Sharon	Lakehoma/1st Grade Teacher Assistant	Lakehoma/Special Ed Teacher Asst.		2013-2014
Weinrich, Mandy	HS/Special Ed Teacher	Lakehoma/Special Ed Teacher		8/21/2013
Day, Kristie	Valley/Teacher Assistant	ME/Noon supervisor & Crosswalk guard		8/16/2013
Covalt, Jennifer	Trails/Teacher Assistant	Horizon/Spec. Education Tchr Assistant		8/27/2013
Hernandez, Sandra	Valley/PM Custodian	Horizon/PM Custodian		8/5/2013
Klein, Reta	Valley/Cafeteria Assistant	Horizon/Cafeteria Assistant		8/14/2013
Hicks, Greg	Trails/Head Custodian	MMS & Centennial/PM Custodian		8/12/2013
Mathes, Brandon	HS/Math Teacher	MMS/Pre-Algebra Teacher		2013-2014
Koonce, Jessica	Trails/Teacher Assistant	Trails/Spec. Ed Teacher Assistant		2013-2014
Platero, Nancy	MMS/PM Custodian	Trails/Custodian		8/9/2013
Scott, Denise	ME/Custodian	Trails/Custodian		8/27/2013
Theдераhn, Mori	Trails/Teacher Assistant	Trails/Spec. Ed Teacher Assistant		8/16/2013
Mansour, Nilgun	MNMS/3.0 hr Cafeteria Assistant	MNMS/5.25 hr Cafeteria Assistant		8/14/2013
Ellison, Danny	MNMS/AM Custodian	HS/PM Custodian		9/3/2013
Fletcher, Deanna	HS/4.0 hr Cafeteria Assistant	HS/6.5 hr Cafeteria Assistant		8/14/2013
Grimes, Kody	District/Custodian Floater	HS/PM Custodian		8/12/2013
Miles, Jody	HS/Asst. Girls Basketball Coach	HS/Asst. Boys Basketball Coach		2013-2014
Nelson, Brian	HS/Custodian	HS/PM Working Supervisor		7/1/2013
Novotny, Kimberly	HS/Cafeteria Assistant	HS/Cafeteria Assistant Manager		8/14/2013
Name		To: Site/Assignment		Effective
Employment				
Hunter, Michelle	New	Canyon Ridge/Crossing Guard		2013-2014
Riley, David	New	Canyon Ridge & Horizon/pm split Custodian		9/3/2013
Wood, Gina	New	Canyon Ridge/6.5 Hr Cafeteria Asst.		2013-2014
Carriger, Laura	Replacement/Amelia Daugherty	Centennial/Noon Supervisor		2013-2014
Higgins, Dawn	Replacement/Julie Chastain	Creek/Third Grade Teacher		2013-2014
Kemnitz, Jessica	New	Creek/Custodian		9/3/2013
Rollins, Jennifer	Replacement/Brandon Lee	Creek/3 hr Cafeteria Asst		2013-2014
Rush, Tiffany	Replacement/Larry Hyatt	Creek/Second Gr Teacher		2013-2014
Casey, Steve	Replacement/Lori Sholer	District/Bus Driver		2013-2014
Prophete, Angela		District/Cafeteria Substitute & Lakehoma/Crosswalk Attendant		2013-2014
Williams, Janet		District/Cafeteria Substitute		2013-2014
England, Amy	Replacement/Lora Estabrook	Lakehoma/Noon Supervisor		2013-2014
Farnsworth, Lawrence	Replacement/Vacant	Lakehoma/3 hr Cafeteria Asst		2013-2014
Gilbert, Brittany	Replacement/Katrina Thomas	Lakehoma/4 hr Cafeteria Asst		2013-2014
Name		To: Site/Assignment		Effective
Employment				
Britt, Danny	Replacement/Bill Scott	ME/Head Custodian		2013-2014
Chilton, Karis	Replacement/Lisa Meyer	MEC/Teacher Assistant		2013-2014

SCHEDULE "A"
September 9, 2013

Patrick, Cynthia	Replacement/Jennifer Linson	Trails/4 hr Cafeteria Asst.		2013-2014
Treadway, Stacey	New	Trails/Title I Reading Resource Tchr		2013-2014
Dougherty, Holly		Valley/Teacher Assistant		2013-2014
Hill, Stacey	New	Valley/First Grade Teacher		2013-2014
Koehn, Renee		Valley/Teacher Assistant		2013-2014
Underwood, Donna	Replacement/Marlene Whisenhunt	Valley/PM Custodian		2013-2014
Wellman, Andrea		Valley/Teacher Assistant		2013-2014
Bosarge, Courtney	Replacement/Connie Scott	MMS/3 hr Cafeteria Asst		2013-2014
Davidson, Sandra	Replacement/Vacant	MMS/3 hr Cafeteria Asst		2013-2014
Glenn, Kimberlie	Replacement/Pamela Ferguson	MMS/Spec Ed Teacher Assistant		2013-2014
Avila, Marie	Replacement/Vacant	HS/6.5 hr Cafeteria Assistant		2013-2014
Bowie, Shelton	Replacement/Brendo Ford	HS/PM Custodian		9/3/2013
Epling, Jared	Replacement/Mandy Weinrich	HS/Special Ed Math Teacher		2013-2014
Franco, Rosa	Replacement/Vacant	HS/6.5 hr Cafeteria Assistant		2013-2014
Hall, Danette	Replacement/Greg Oswald	HS/Teacher		2013-2014
Keel, Jake	Replacement/Liz Jones	HS/Special Ed. Teacher Assistant		2013-2014
Maness, Barbara	Replacement/Lenise Davidson	HS/6.5 hr Cafeteria Assistant		2013-2014
Pruneau, Donna	Replacement/Deanna Fletcher	HS/4 hr Cafeteria Assistant		2013-2014
Raisley, Brent	Replacement/Darrin Dean	HS/Science Teacher		2013-2014
Russell, Bret	New	HS/Spanish Teacher		8/29/2013
Name		Site/Assignment		Effective
Extra-Duty/Supplemental:				
Stout, Sohailah		Canyon Ridge/Music Position		2013-2014
Peery, Bobbi		Canyon Ridge/Math Data Analyst		2013-2014
Karn, Heather		Canyon Ridge/Awards Prog. Coordinator		2013-2014
Fletcher, Teresa		Centennial/First Grade Team Ldr		2013-2014
Gray, Susan		Centennial/Sp. Ed Department Chair		2013-2014
Harrison, Cheryl		Centennial/Fourth Grade Team Ldr & Awards Program Coordinator		2013-2014
Henagar, Kayla		Centennial/Site Webmaster		2013-2014
Langston, Sharrie		Centennial/Specials Team Ldr		2013-2014
Locke, Laurie		Centennial/PD Committee Chair		2013-2014
Luper, Amanda		Centennial/Third Grade Team Ldr		2013-2014
Mahan, Stephanie		Centennial/Kdg. Team Leader		2013-2014
Simmons, Janette		Centennial/PreK Team Leader		2013-2014
Stein, Nikki		Centennial/Math Data Analyst		2013-2014
Waldrop, Whitney		Centennial/Elem. Vocal Music		2013-2014
Wood, Windy		Centennial/Second Grade Team Ldr		2013-2014
Brown, Martha	Replacement/Rachel McDaniel	Horizon/Life App Elective Team Ldr.		2013-2014
McDaniel, Rachel		Horizon/Yearbook Sponsor		2013-2014
Bornemann, Britney		Horizon/Student Council Sponsor		2013-2014
Fruit, Andrea		Horizon/6th Gr. Scholastic Coach		2013-2014
Watson, Misti		Horizon/Math Data Analyst		2013-2014
Brandon, Kari		Lakehoma/Kindergarten Team Leader		2013-2014
Name		Site/Assignment		Effective
Extra-Duty/Supplemental:				
Lindsey, Hillary		Lakehoma/First Grade Team Leader		2013-2014
Barber, Liz		Lakehoma/Second Grade Team Leader & Math Data Analyst		2013-2014
Koeninger, Jennifer		Lakehoma/Third Grade Team Leader		2013-2014
Bailey, Vicki		Lakehoma/Fourth Grade Team Leader		2013-2014
McCullough, Paula		Lakehoma/Student Services Team Leader		2013-2014

SCHEDULE "A"
September 9, 2013

Jones, Amy		Lakehoma/Essentials Team Leader		2013-2014
DeMoss, Mary		Lakehoma/Awards Assembly Coordinator & Student Council Sponsor		2013-2014
Prather, Jenny		Lakehoma/Webmaster		2013-2014
Choate, Angie		Lakehoma/Yearbook		2013-2014
Bernhardt, Tanya		ME/Yearbook Coordinator		2013-2014
Bullard, Kelly		ME/Student Council Sponsor		2013-2014
Evans, Madalyn		ME/Fourth Grade Team Leader		2013-2014
Hill, Gwendolyn		ME/First Grade Team Leader		2013-2014
Mangus, Kaylee		ME/Site Webmaster		2013-2014
Watkins, Kayla		ME/Second Grade Team Leader		2013-2014
Wildman, Andrea		ME/Kdg. Team Leader		2013-2014
Williamson, Daryl		ME/Specials Team Leader		2013-2014
Wood, Nita		ME/Third Grade Team Leader		2013-2014
Cherian, Lisa		Trails/Spec. Ed Department Head		2013-2014
Cummings, Shanda		Trails/Grade Level Team Leader		2013-2014
Fowler Amber		Trails/Grade Level Team Leader		2013-2014
Gelso, Christin		Trails/Yearbook Sponsor		2013-2014
Johnson, Cindy		Trails/Grade Level Team Leader		2013-2014
Johnson, Diane		Trails/Elem. Vocal Music		2013-2014
McDaniel, Tammy		Trails/Awards Program Coordinator		2013-2014
Reyes, Allison		Trails/Math Data Analyst		2013-2014
Sabo, Cathy		Trails/Grade Level Team Leader		2013-2014
Slupe, Julie		Trails/Specials Team Leader		2013-2014
Thomas, Amanda		Trails/Elem. Vocal Music		2013-2014
Walther, Mallory		Trails/Student Council Sponsor		2013-2014
Weismann, Rebecca		Trails/Site Webmaster & Grade Level Team Leader		2013-2014
Collins, Jacob		MMS/Team Leader		2013-2014
Prock, Jared		HS/Assistant Baseball Coach		2013-2014
Wilson, Christina		HS/Assistant Girls Basketball		2013-2014
Wilson, Justin		HS/Student Council		2013-2014
Day, Alecia		HS/Student Council		2013-2014
Caudle, Katelyn		HS/Student Council & Speech/Debate		2013-2014
Dillard, Joni		HS/Senior Sponsor		2013-2014
Chavez, Rose		HS/Senior Sponsor		2013-2014
Faulkner, Cathy		HS/Senior Sponsor		2013-2014
Hyden-Hix, Melanie		HS/Junior Sponsor & Yearbook		2013-2014
Stewart, Ashley		HS/Junior Sponsor		2013-2014
Lindsey, Brenda		HS/Junior Sponsor & Prof.Dev. Chair		2013-2014
Edgmon, Ryan		HS/Instrumental Music Head		2013-2014
Name		Site/Assignment		
Extra-Duty/Supplemental:				
Hofer, Jacob		HS/Instrumental Music Assistant		2013-2014
Mangus, Greg		HS/Instrumental Music Assistant		2013-2014
Watson, Belinda		HS/Instrumental Music Assistant		2013-2014
Thompson, Gina		HS/Instrumental Music Assistant		2013-2014
Jussila, Dustin		HS/Instrumental Music Assistant		2013-2014
Gass, Cynthia		HS/Vocal Music Head		2013-2014
Easley, Stephanie		HS/Vocal Music Assistant		2013-2014
Farnham, Emily		HS/Drama		2013-2014
Garner, Tom		HS/Honor Society& Science Dept. Head		2013-2014
Vaughan, Matt		HS/Scholastic Coach		2013-2014
Hammer, Valerie		HS/Language Arts Dept. Head		2013-2014

Schedule "B"
September 9, 2013

Continued employment for Support Personnel for 2013-2014			
Martin, Bob			
Support Personnel Substitutes at \$7.25 per hour			
Anderson, Susan	Davis, Kristina	Honohan, Carol	Reynolds, Angie
Ayala, Antonieta	Davis, Tammy	Langham-McClain, Jessica	Ridinger, Melanie
Beltran, Diana	Day, Kristie	Lauen, Ashley	Schwartz, Betty Lou
Berndt, Ashley	Devonshire, Maria Elena	LeGrand, Lisa	Scott, Melissa
Bertholf, Renae	Dougherty, Holly	Lewis, Kaitlin	Simmons, Ronda
Birdsley, Christina	Dunn, Holly	Loch, Peter	Steele, Alison
Boehnlein, Theresa	Elwell, Judy	McNeil, Melinda	Thompson, Brenda
Bottoms, Marian	Elwess, Dianna	Miller, Mary	Walker, Sonja
Cabral, Sharon	Floyd, Taylor	Miller, Shelly	Walls, Sharon
Charles, Raimey	Glyckherr, Joe	Moreland, Nancy	Wentworth, Kylie
Coker, Ashley	Grabeal, Billie	Murar, Claudia	Wilson, Christina
Coker, Patricia	Gray, Angeliqa	Obannon, Nicole	Wycoff, Debra
Collum, Jerry	Greene, Anna	Porschien, Catherine	
Cummings, Serena	Hammer, Carl	Putnam, Cindy	
Curtis, Beverly	Henagar, Rochelle	Rees, Janet	
Non-Certified/Non-Degreed Substitutes at \$60 per day			
Beltran, Diana	Davis, Kristina	Greene, Scott	Porschien, Catherine
Bertholf, Renae	Davis, Tammy	Hammer, Carl	Putnam, Cindy
Birdsley, Christina	Day, Kristie	Henagar, Rochelle	Rees, Janet
Boehnlein, Theresa	Devonshire, Maria Elena	Honohan, Carol	Reynolds, Angie
Bottoms, Marian	Dougherty, Holly	Immenschuh, Barbara	Ridinger, Melanie
Brown, Phyllis	Dunn, Holly	Langham-McClain, Jessica	Schwartz, Betty Lou
Buckley, Thomas	Elwess, Dianna	Lewis, Kaitlin	Scott, Melissa
Burkitt, Jessica	Floyd, Taylor	Loch, Peter	Steele, Alison
Cabral, Sharon	Glyckherr, Joe	Miller, Mary	Walls, Sharon
Coker, Patricia	Grabeal, Billie	Miller, Shelly	
Cummings, Serena	Gray Angeliqa	Moreland, Nancy	
Curtis, Beverly	Greene, Anna	Murar, Claudia	
Non-Certified/Degreed Substitutes at \$60 per day			
Anderson, Susan	Choate, Sean	McNeil, Melinda	Whitehead, Katrina
Ayala, Antonieta	Crawford, Chasity	Reed, Jamie	Wilson, Christina
Bean, Aimee	Elwell, Judy	Ridenhour, Ralph	Wycoff, Debra
Berndt, Ashley	Keith, Sara	Simmons, Ronda	
Bowman, Janice	Lauen, Ashley	Walker, Sonja	
Brock, Andrew	LeGrand, Rachel	Welch, Sandi	
Charles, Raimey	Leonard, Ralph Greg	Wentworth, Kylee	
Certified Substitutes at \$70 per day			
Cardenas, Randy	Hathaway, Brenda	Obannon, Nicole	Steiner, David
Childress, Debra	Johnson, Pallas	Porter, Jimmie	Steiner, Quannah
Collum, Jerry	LeGrand, Lisa	Pruett, Katie	Sturdy, Patricia
Crabtree, Kathy	Moen, Jane	Seiler, Susan	Thompson, Brenda
Hamilton, Cindy	Norris, Patricia	Smei, Mahria	Vollmer, Mary