



**"OPEN MEETINGS ACT"**

**City of Blair Regular Parks, Recreation and Cemetery Advisory Board  
Meeting  
City Council Chambers  
October 21, 2025 - 5:30 PM**

**A Copy of the "Open Meetings Act" Has Been Posted at Both Exits**

**AGENDA**

**NOTE: A current copy of the agenda can be obtained at the City Clerk's Office at 218 S. 16th Street, Blair, Nebraska or on the City website at [www.blairnebraska.org](http://www.blairnebraska.org). The City Council reserves the right to go into Executive Session at any time.**

1. Meeting called to order by Chairperson Jensen at 5:30 p.m.
2. Roll Call of members.
3. Approval of minutes from the September 16, 2025, meeting.
4. Budget report for September 2025
5. Discussion and possible action regarding an addition of a columbarium at the Blair Cemetery.
6. Discussion and possible action permitting multiple cremations per burial lot.
7. Discussion and possible action regarding potential renovations to the disc golf course at Black Elk - Neihardt Park.
8. Review and consider bids for the purchase and installation of dog park fencing project.
9. Review and consider bid for the purchase of a Bobcat Toolcat (UTV) for the Parks Department
10. Staff Report.
11. Motion and second by Council members to adjourn the meeting.

**A Copy of the "Open Meetings Act" Has Been Posted at Both Exits**

City of Blair Regular Parks, Recreation and Cemetery Advisory Board Meeting  
September 16, 2025

Agenda Item #1 - The Parks, Recreation and Cemetery Advisory Board met in regular session in the City Council Chambers on September 16, 2025 at 5:30 PM and called to order by Chairperson Jensen.

The Chairperson publicly stated to all in attendance that a current copy of the Nebraska Open Meetings Act was available for review and indicated the location of such copy posted in the room where the meeting was being held. Notice of the meeting was given in advance thereof by publication in the Enterprise or the Pilot -Tribune as shown by the affidavit of publication filed in the City Clerk's office. Notice of the meeting was simultaneously given to all members of the Parks, Recreation and Cemetery Advisory Board and the agenda is filed in the City Clerk's office. Availability of the agenda was communicated in the advance notice and in the notice to the Board of this meeting. All proceedings shown hereafter were taken while the convened meeting was open to the attendance of the public.

Agenda Item #2 - Roll Call of members – The following were present: Betsy Anderson, Sarah Boeka, Joe Burns, Neil Jensen, Kristi Rounds. Absent: Todd Wick. Also present were City Administrator Green, Director of Public Works Heaton, and Non-Lawyer Assistant Ferrari.

Agenda Item #3 - Approval of minutes from the August 19, 2025 - Motion by Betsy Anderson, second by Kristi Rounds to approve the Minutes from August 19, 2025 meeting. Members voted as follows: Betsy Anderson: Yea, Sarah Boeka: Yea, Joe Burns: Yea, Neil Jensen: Yea, Kristi Rounds: Yea, Todd Wick: Absent. All Board members voted: Yea: 5, Nay: 0, Absent: 1. Chairperson Jensen declared the motion carried.

Agenda Item #4 - Budget report for August, 2025 – Chairperson Jensen stated the budget report for August, 2025 is presented for review. No action required.

Agenda #5 - Discussion and possible action regarding Dog Park Rules and Regulations – Public Works Director Heaton presented the dog park rules for approval. They include: 1) The dog park is for dogs and their owners only – handlers must be at least 16 years old; 2) No more than two dogs per handler; 3) Owners must remain in the park and always keep dogs within sight and control; 4) All dog waste must be cleaned up by the owner; 5) No food, treats, or glass containers permitted in the dog park area; 6) No smoking or alcohol use in the dog park; 7) All dogs shall be leashed before entering and after exiting the dog park; 8) Aggressive dogs are not allowed; 9) Puppies using the dog park must be 4 months old and fully vaccinated; 10) All dogs must be current on all vaccines and licenses; 11) Dogs must have a collar with ID tags while in the dog park; 12) Dogs in heat shall not use the dog park; 13) Owners are responsible for their dog's behavior and any injuries or damage caused by their dog; 14) Dogs showing signs of illness shall not enter the dog park; 15) Dogs should use the appropriate section for the size of the dog. Heaton confirmed the rules and regulations will be posted at the park and online. Bids for fencing will go out shortly. As previously discussed, the streets department will complete the concrete work for sidewalks and picnic table pads while the parks department will clear shrubs and trees to clean up the area and enhance the view. The project should be completed before the start of winter. Security cameras will be installed off the water pump house at a later date. Motion by Kristi Rounds, second by Joe

Burns to recommend approving the proposed rules and regulation for dog park. Members voted as follows: Betsy Anderson: Yea, Sarah Boeka: Yea, Joe Burns: Yea, Neil Jensen: Yea, Kristi Rounds: Yea, Todd Wick: Absent. All Board members voted: Yea: 5, Nay: 0, Absent: 1. Chairperson Jensen declared the motion carried.

Agenda #6. Discussion and possible action regarding installation of pickleball windscreens  
– Public Works Director Heaton reported George Hall successfully fundraised money to be used for the installation of windscreens around the pickleball courts. Park Supervisor Bilslend reached out to multiple vendors for bids and received one back from Odeys in the amount of \$4,749.55. Heaton confirmed the estimate is for materials only and the installation will be completed by the Parks Department. The windscreens will go around the full perimeter of the four courts. Burns questioned whether the windscreens would be up year-round, and it was confirmed they would be taken down during the winter months. George Hall, 1234 Corey Drive, addressed the Board to asking if there would be a gap at the top and bottom for adequate airflow. Bilslend confirmed there would be appropriate airflow. Board member Anderson extended a huge thank you to Mr. Hall for his efforts in fundraising the necessary funds. The windscreens will be purchased but not installed until spring of 2026. Motion by Betsy Anderson, second by Kristi Rounds to recommend approving the installation of pickleball windscreens using funds raised by George Hall with additional support from Keno or Washington County Foundation funds if necessary. Members voted as follows: Betsy Anderson: Yea, Sarah Boeka: Yea, Joe Burns: Yea, Neil Jensen: Yea, Kristi Rounds: Yea, Todd Wick: Absent. All Board members voted: Yea: 5, Nay: 0, Absent: 1

Agenda #7 - Staff Report - Public Works Director Heaton reviewed the budget that was approved at the previous Council Meeting. He highlighted a few key items including: 1) \$27,500 for Security cameras at Lyons Park; 2) \$14,000 fertilizer buggy/salt spreader; 3) \$130,000 for a BobCat Toolcat, dump trailer, and dedicated mower for Vets field; 5) \$64,000 for upgraded and standardized signage, furniture, and trashcans across all parks, and new tables and chairs for the Depot. Board member Anderson inquired about the bathroom improvements for Hardy RV Park that were removed from this year's budget. She requested they be added to next year's budget. Anderson also questioned if the \$31,000 designated for a shop study was necessary. City Administrator Green explained the study is essential because it allows a professional to analyze present, future and possible unknown needs. Public Work Director Heaton provided an update on the installation of the security cameras. IT Director White is currently installing cameras at Generations Park and will then move to Lyons Park. Heaton announced the City received a \$10,000 Water Security Fund grant to install fiber to sites including the water plant, pump stations and wells. Many of these are in or near city parks and it is his hope that all parks will have camera coverage within 3-5 years. Heaton, Bilslend, and the Board extended a special thank you to Pastor Glen and the 30 volunteers for their contribution in the extensive clean-up of Potters Field in the Blair Cemetery. Pastor Glen Thomas, 657 N 22nd Street, addressed the Board indicating that over half the site has been cleared. They identified 22 markers and remnants of wooden markers leading them to believe there are likely more than 50 graves in the area. The next steps include preventing erosion, maintenance, and a possible long-term memorial.

Agenda #8 – Adjournment - Motion by Neil Jensen, second by Joe Burns to adjourn the meeting at 6:07 p.m. Members voted as follows: Betsy Anderson: Yea, Sarah Boeka: Yea, Joe Burns: Yea, Neil Jensen: Yea, Kristi Rounds: Yea, Todd Wick: Absent. All members voted: Yea: 5, Nay: 0, Absent: 1. Chairperson declared the motion carried.



**BUDGET REPORT**  
**CALENDAR 9/2025, FISCAL 12/2025**

**PCT OF FISCAL YTD 100.0%**

ACCOUNT NUMBER	ACCOUNT TITLE	TOTAL BUDGET	PTD BALANCE	YTD BALANCE	PERCENT EXPENDED	UNEXPENDED
01-014-5001	SALARIES	320,000.00	24,097.86	347,717.51	108.66	27,717.51-
01-014-5002	FICA - CITY SHARE	24,480.00	1,741.57	26,235.59	107.17	1,755.59-
01-014-5003	WORKMAN'S COMPENSATION	6,400.00	.00	9,068.95	141.70	2,668.95-
01-014-5004	H.A.L. INSURANCE	120,050.00	7,965.06	106,719.38	88.90	13,330.62
01-014-5005	RETIREMENT - CITY SHARE	22,400.00	1,332.59	27,618.53	123.30	5,218.53-
01-014-5006	UNEMPLOYMENT COMP	500.00	.00	.00	.00	500.00
01-014-5007	DISABILITY	2,000.00	88.97	1,238.94	61.95	761.06
01-014-5008	PENSION ADMINISTRATION	500.00	.00	229.05	45.81	270.95
	PERSONAL SERVICES TOTAL	496,330.00	35,226.05	518,827.95	104.53	22,497.95-
01-014-5209	BANK FEES	.00	.00	.00	.00	.00
01-014-5210	LEGAL	4,000.00	68.40	1,266.21	31.66	2,733.79
01-014-5211	AUDITING	2,500.00	.00	2,338.90	93.56	161.10
01-014-5212	ENGINEERING/CONSULTANT	4,000.00	135.00	8,420.97	210.52	4,420.97-
01-014-5213	PROFESSIONAL SERVICES	150.00	.00	.00	.00	150.00
01-014-5215	EMPLOYEE APPREC/SCHOOLING	1,500.00	.00	830.34	55.36	669.66
01-014-5216	POSTAGE	100.00	.00	7.50	7.50	92.50
01-014-5217	PRINTING & PUBLICATION	2,500.00	9.09	412.52	16.50	2,087.48
01-014-5222	TRAVEL EXPENSE	800.00	.00	.00	.00	800.00
01-014-5223	TRAINING EXP/CONF REGISTR	800.00	.00	305.00	38.13	495.00
01-014-5224	DUES	500.00	.00	318.63	63.73	181.37
01-014-5227	SOFTWARE MAINTENANCE	6,500.00	880.29	5,744.23	88.37	755.77
01-014-5228	UTILITIES	34,000.00	1,085.99	39,824.10	117.13	5,824.10-
01-014-5229	TELEPHONE	3,000.00	270.64	3,358.95	111.97	358.95-
01-014-5230	VEHICLE INSURANCE	4,000.00	.00	4,952.13	123.80	952.13-
01-014-5231	LIABILITY INSURANCE	2,500.00	.00	1,456.84	58.27	1,043.16
01-014-5232	BLDG & CONTENT INSURANCE	24,000.00	.00	29,749.12	123.95	5,749.12-
01-014-5236	RADIO MAINTENANCE	100.00	.00	.00	.00	100.00
01-014-5239	MOTORIZED EQUIPMENT MAINT	10,000.00	437.44	12,373.86	123.74	2,373.86-
01-014-5240	BUILDING MAINTENANCE	40,000.00	783.15	21,273.80	53.18	18,726.20
01-014-5241	TREE/STUMP REMOVAL & PLANTING	15,000.00	.00	25,189.86	167.93	10,189.86-
01-014-5244	RECREATION ASSISTANCE	53,000.00	.00	33,085.91	62.43	19,914.09
01-014-5245	MEDICAL	4,000.00	.00	430.15	10.75	3,569.85
01-014-5253	REPURCHASE CEMETERY LOTS	600.00	.00	2,800.00	466.67	2,200.00-
01-014-5258	OTHER OP EXP/FIRE WORKS	7,500.00	.00	20,000.00	266.67	12,500.00-
01-014-5259	BLACK ELK MAINTENANCE	2,000.00	.00	.00	.00	2,000.00
01-014-5263	OPTIMIST BOAT RAMP	3,000.00	.00	.00	.00	3,000.00
01-014-5266	CONTRACT MOWING	80,000.00	18,849.87	102,443.05	128.05	22,443.05-
01-014-5281	BUILDING REPAIR STORM	1,000.00	.00	4,000.00	400.00	3,000.00-
	OPERATING EXPENSE TOTAL	307,050.00	22,519.87	320,582.07	104.41	13,532.07-
01-014-5359	OFFICE EQUIPMENT	1,000.00	.00	.00	.00	1,000.00
01-014-5360	OFFICE SUPPLIES	1,000.00	.00	454.51	45.45	545.49
01-014-5361	JANITORIAL SUPPLIES	4,400.00	144.14	2,546.58	57.88	1,853.42
01-014-5363	CHEMICALS	6,500.00	29.68	5,930.14	91.23	569.86

**BUDGET REPORT**  
**CALENDAR 9/2025, FISCAL 12/2025**

**PCT OF FISCAL YTD 100.0%**

ACCOUNT NUMBER	ACCOUNT TITLE	TOTAL BUDGET	PTD BALANCE	YTD BALANCE	PERCENT EXPENDED	UNEXPENDED
01-014-5364	SEED, SOD, ETC	3,000.00	1,700.00	3,624.25	120.81	624.25-
01-014-5365	RECREATIONAL SUPPLIES	8,500.00	.00	9,380.24	110.36	880.24-
01-014-5369	SAFETY EQUIPMENT/TRAINING	1,850.00	34.89	1,492.89	80.70	357.11
01-014-5370	GAS/OIL/DIESEL	8,000.00	881.40	9,575.21	119.69	1,575.21-
01-014-5371	UNIFORMS	1,500.00	236.56	2,949.85	196.66	1,449.85-
01-014-5372	BOOKS & MAPS	100.00	.00	.00	.00	100.00
01-014-5373	SMALL TOOLS	2,000.00	.00	2,156.95	107.85	156.95-
01-014-5374	SAND/ROCK/GRAVEL	4,000.00	1,680.00	1,680.00	42.00	2,320.00
01-014-5383	OTHER EXPENSE MATL & SUPP	3,500.00	2,001.70	3,445.78	98.45	54.22
01-014-5389	PURCHASE/GRANT	.00	.00	.00	.00	.00
01-014-5395	NON-CAPITAL EQUIPMENT	.00	.00	.00	.00	.00
	EXPENDABLE MAT & SUPPLIES TOTA	45,350.00	6,708.37	43,236.40	95.34	2,113.60
01-014-5399	MOTORIZED EQUIP/GRAVE OPENING	22,500.00	1,000.00	9,000.00	40.00	13,500.00
	RENTAL EXPENSE TOTAL	22,500.00	1,000.00	9,000.00	40.00	13,500.00
01-014-5401	OFFICE EQUIPMENT	7,000.00	.00	.00	.00	7,000.00
01-014-5402	MOTORIZED EQUIPMENT (SMALL)	5,000.00	.00	17,057.56	341.15	12,057.56-
01-014-5403	MOTORIZED EQUIPMENT (LARGE)	30,000.00	.00	37,190.80	123.97	7,190.80-
01-014-5419	OTHER IMPROVEMENTS/PARK SIGNS	4,000.00	.00	.00	.00	4,000.00
	OTHER CAPITAL OUTLAY TOTAL	46,000.00	.00	54,248.36	117.93	8,248.36-
01-014-5502	BUILDING/RESTROOM	25,000.00	.00	.00	.00	25,000.00
01-014-5504	PAVING	20,000.00	.00	3,846.50	19.23	16,153.50
01-014-5519	PLAYGROUND EQUIPMENT	7,500.00	.00	3,805.12	50.73	3,694.88
01-014-5520	CAPITAL PROJECT/RESERVE	2,700,000.00	10,400.00	2,033,480.35	75.31	666,519.65
01-014-5521	OTHER IMPROVEMENTS	.00	.00	.00	.00	.00
01-014-5523	CAPITAL CONST PROJECT/RES	.00	.00	.00	.00	.00
01-014-5531	RESURFACE TENNIS COURTS	.00	.00	.00	.00	.00
	CAPITAL IMPROVEMENTS TOTAL	2,752,500.00	10,400.00	2,041,131.97	74.16	711,368.03
	PARK TOTAL	3,669,730.00	75,854.29	2,987,026.75	81.40	682,703.25

# MEMORANDUM

TO: Blair Parks, Recreation, and Cemetery Board  
From: CJ Heaton, Deputy City Administrator of Public Works  
Date: 10/14/25  
Re: Columbarium at the Blair Cemetery

Attached is some information and pricing on potential columbaria at the Blair Cemetery. Staff would like to get input from the board on the possibility of purchasing and creating a columbarium memorial area at the cemetery.

**Staff Recommendation:** Seeking opinion and possible action.

**Financial Impact:** NA

# Columbaria Guide



Create a Lasting Tribute

What you need to know  
when purchasing  
a columbarium.



employee owned | established 1917



# INDEX

Glossary.....	5-6
Purpose of a Columbarium.....	7
The Niche / Niche Door.....	8
Operation & Maintenance.....	9-10



## GLOSSARY

### Break-Even Pricing

A method of pricing niches without regard of creating a surplus for the general operational fund or of the cost of placement.

### Columbarium

A structure that holds urns containing cremated remains. The term comes from the Latin word columba, which means "dove". Columbaria are often designed with niches that resemble dove coves.

### Community Mausoleum

A structure that contains niches that are open to the public.

### Companion Niche

A space in a columbarium that can hold two urns.

### Cremains

A socially accepted term for Cremated Remains, the ashes of a body that have been cremated.

### Foundation

A level concrete pad on which a columbarium is installed. In most cases it should be supported with a frost foundation.

### Inurnment

The process of placing the urn containing cremains into a permanent niche in the columbarium.

### Niche

A compartment or cubicle in a columbarium for the memorialization and permanent placement of the urn containing a person's cremated remains.

### Urn

A receptacle where the cremated remains are placed after a cremation has taken place.



## Purpose of Columbarium:

A columbarium provides a respectful and necessary structure to place the cremated remains of loved ones. Many Americans are opting for cremation in increasing numbers and cemeteries are seeing decreasing revenue due to this trend. A columbarium provides a beautiful place for burial and allows more space for inurnments occupying less property.

## What is a Columbarium:

A columbarium contains rows and columns of niches on a wall or round structure, that provides a place for cremated remains. They can vary in the number of niches and the shape of the structure.

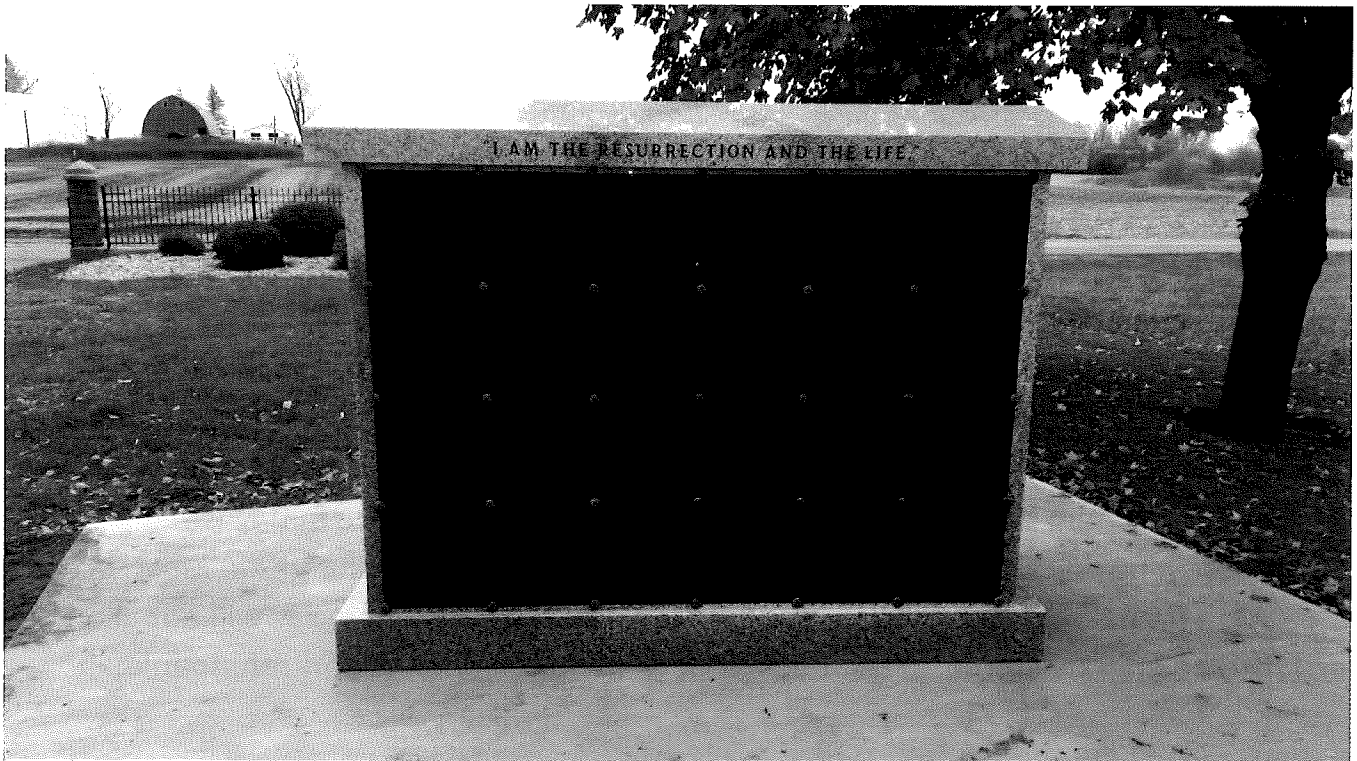

Add different sizes here

## The Niche:

A standard niche is typically a cube, 12" x 12" x 12" and made of granite (igneous rock). One niche can hold 1 or 2 sets of ashes, depending on the size of the urns.

## The Niche Cover/Door:

The face plate / cover / door of the niche displays the names and dates of the deceased. The names and dates are commonly engraved into the granite but may also be marked with a bronze plate.

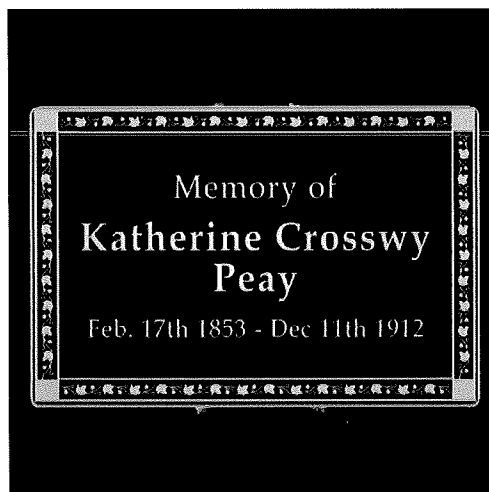

It is recommended to be consistent with the doors to make it aesthetically pleasing.

Many columbarium operators do not engrave the covers until the family is ready to use them. Opening and closing of the doors and engraving costs are charges per instance. To engrave a name on without a date doubles the cost. Many cemeteries will not allow the cover to be engraved prior to use because it renders the door as non-refundable.

## Operation & Maintenance:

The operation of the columbarium consists of the sale of the niches, the placement of the urns, and general maintenance.

**Niche Sales:** Each niche can be purchased from the church / cemetery just as a grave space is purchased. You will be provided with a template to track sales and placement dates of each inurnment.

	Column 1	Column 2	Column 3	Column 4	Column 5	Column 6	Cost per niche
Row 1	Purchased: <b>Johnson</b> James Date: Judy Date:	Purchased: Date:	Purchased: Date:	Purchased: Date:	Purchased: Date:	Purchased: Date:	
Row 2	Purchased: Date: Date:	Purchased: Date: Date:	Purchased: Date: Date:	Purchased: Date: Date:	Purchased: Date: Date:	Purchased: Date: Date:	
Row 3	Purchased: Date: Date:	Purchased: Date: Date:	Purchased: Date: Date:	Purchased: Date: Date:	Purchased: Date: Date:	Purchased: Date: Date:	
Row 4	Purchased: Date: Date:	Purchased: Date: Date:	Purchased: Date: Date:	Purchased: Date: Date:	Purchased: Date: Date:	Purchased: Date: Date:	

**Inurnment:** The family or funeral home will make arrangements with you for the date and time of the inurnment much like a ground inurnment. During or before the service the plate is removed for the service to include placement of the urn into the niche with the family present.

**Niche Door Operation:** A suction cup handle is commonly used to remove the niche cover, and the door is manipulated within the grooves to lift it out.

Example:

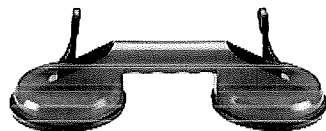

After the door is returned to its original position, it should be caulked to keep out the weather and insects.

**Maintenance:** We recommend that a columbarium be constructed of granite. It will require minimal maintenance, which may include pressure washing over time.

## The Mausoleum Foundation:

The foundation work may be installed by the cemetery or an outside source. It is important to review the county/state regulations on proper footing depth.

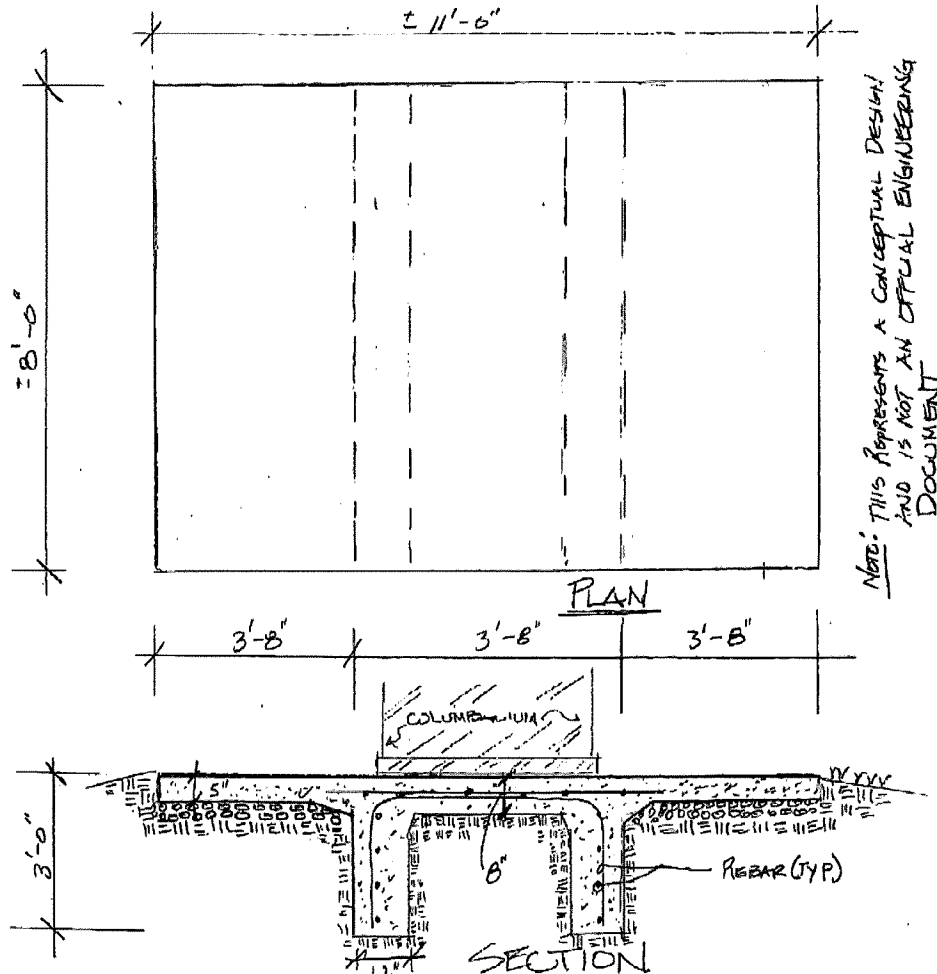

One of many common plans for the foundation.

## Crane Considerations:

The size and weight of the columbarium you are installing will determine the size of the crane needed to install the columbarium on the foundation. Crane expenses should be reviewed with your local crane operators.

## Planning for Expansion:

It is important to consider the future of the cemetery and plan for expansion of the mausoleum area. Determine the amount of land you want to occupy and we can create a custom layout.

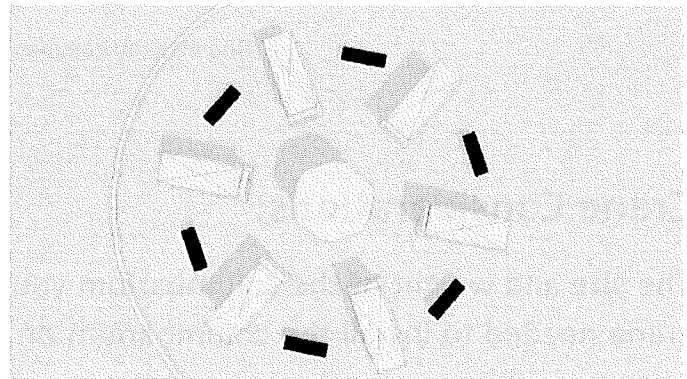
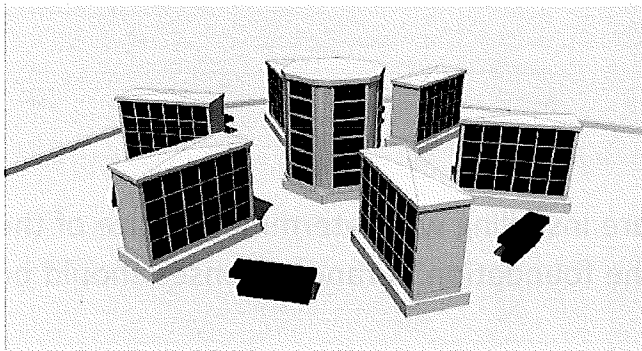
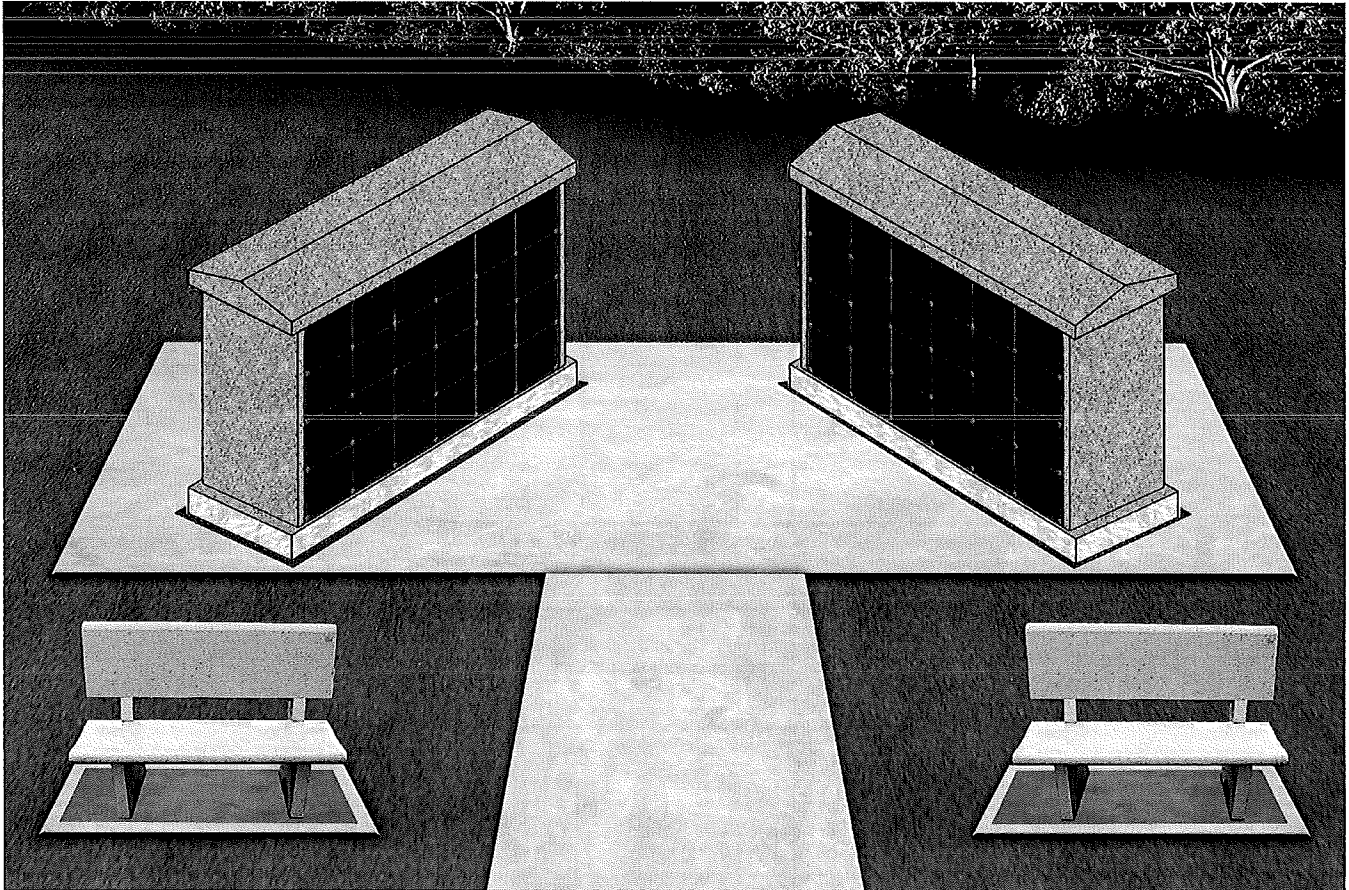

Examples of Master Planning shots

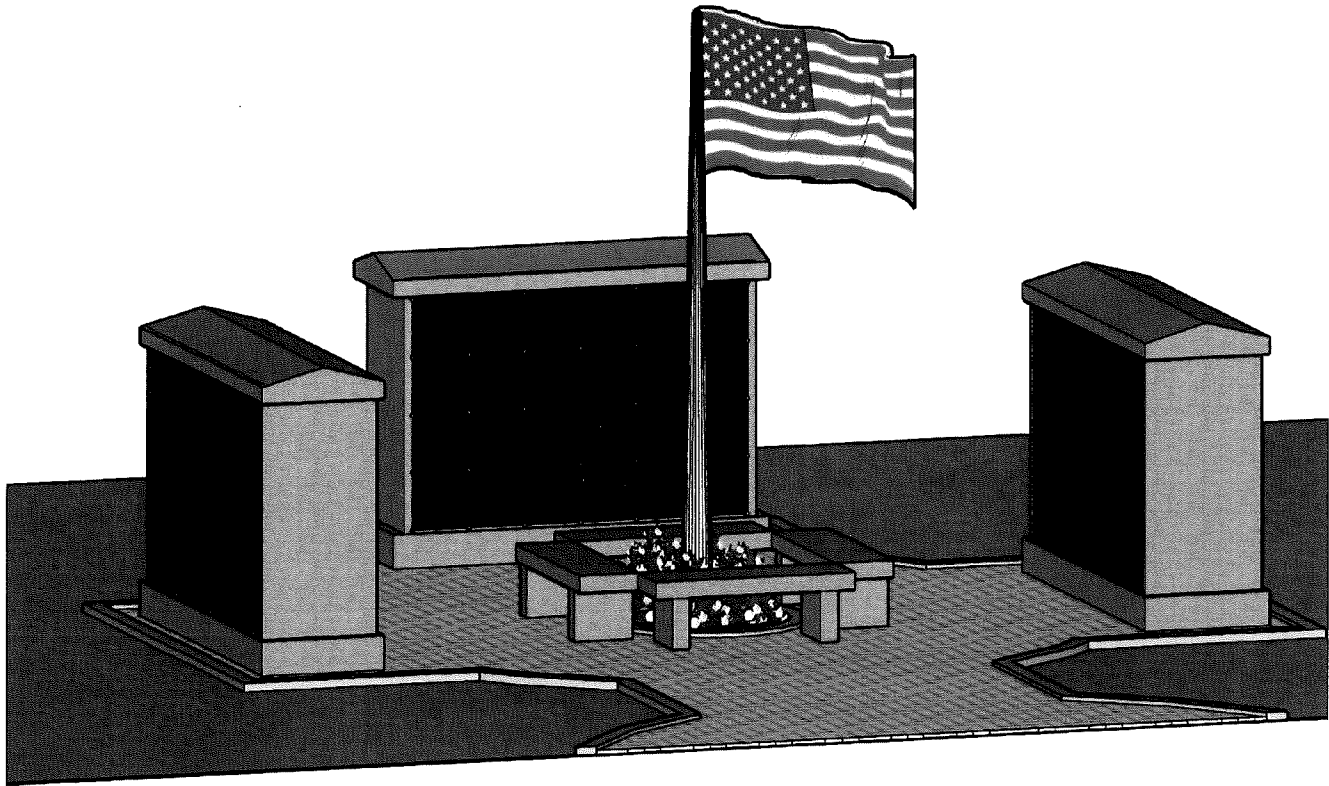

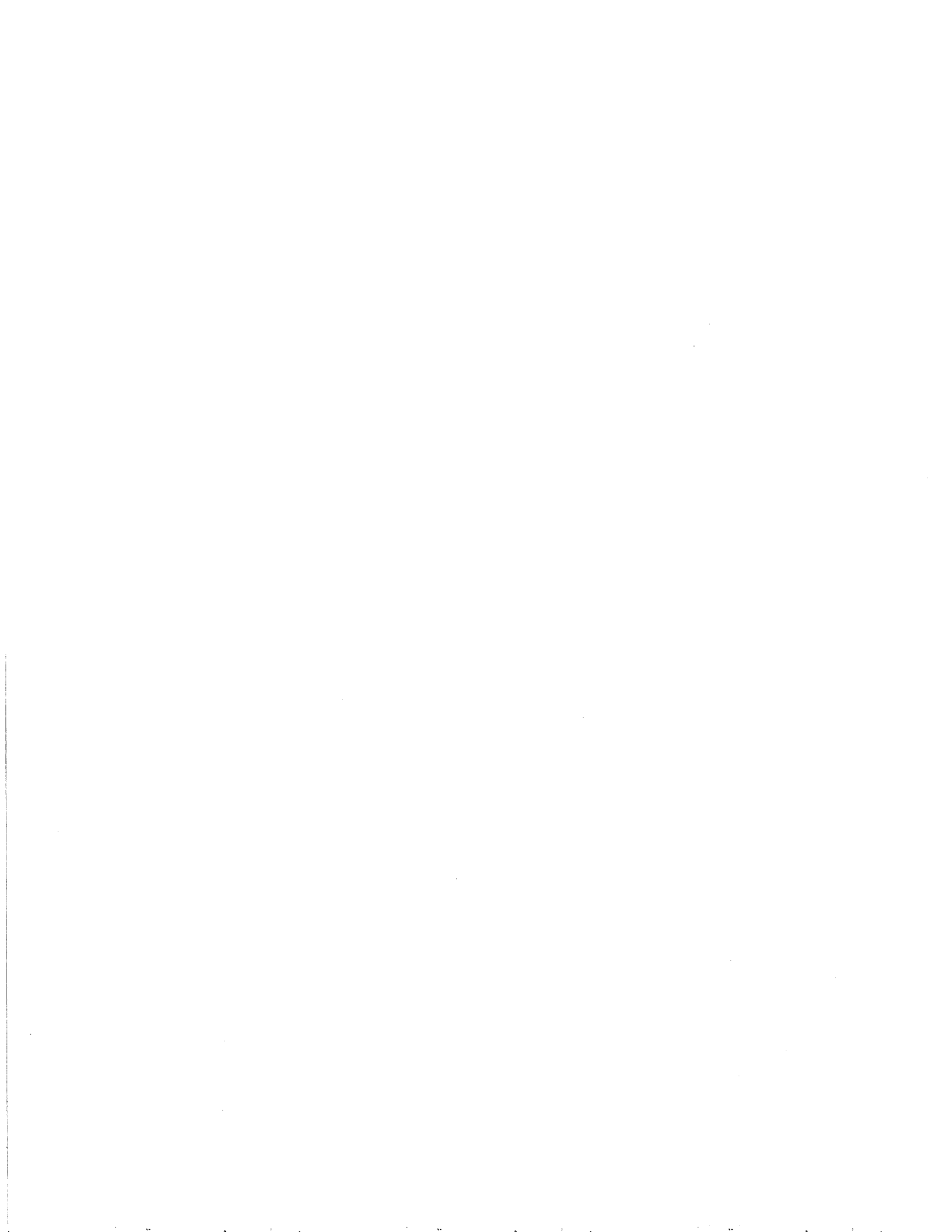

# Columbariums

## 48 NICHE COLUMBARIUM

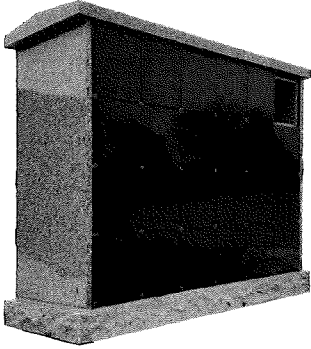

48 Niche Columbarium  
2 sided with a pitched roof  
4 niches high by 6 niches wide  
Grey Trim  
Jet Black Niche Fronts  
Retail: \$30,100

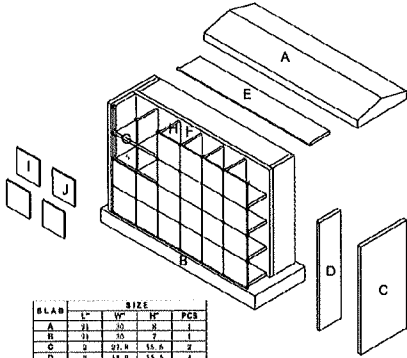

BLANK	SIZE			PCB
A	L"	W"	H"	
A	31	35	8	1
B	31	35	7	1
C	2	12.5	15.5	2
D	2	12.5	15.5	1
E	25	12.5	1.5	1
F	31	35	15.5	1
G	17	12	1.5	0
H	1	12	17	10
I	11.5	0.2	13.5	16
J	12	0.2	13.5	25
TOTAL	2525/274			107

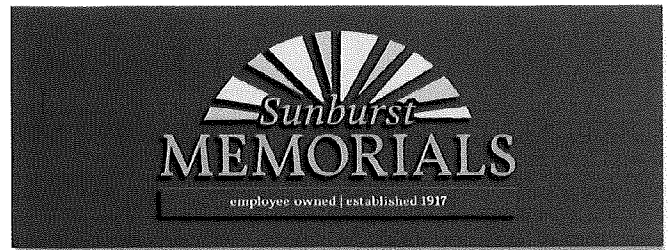

### Choose From

- ▶ Niche covers be carved or etching available in jet black
- ▶ Vase not included
- ▶ Many different colors/combinations
- ▶ Request a quote for additional colors

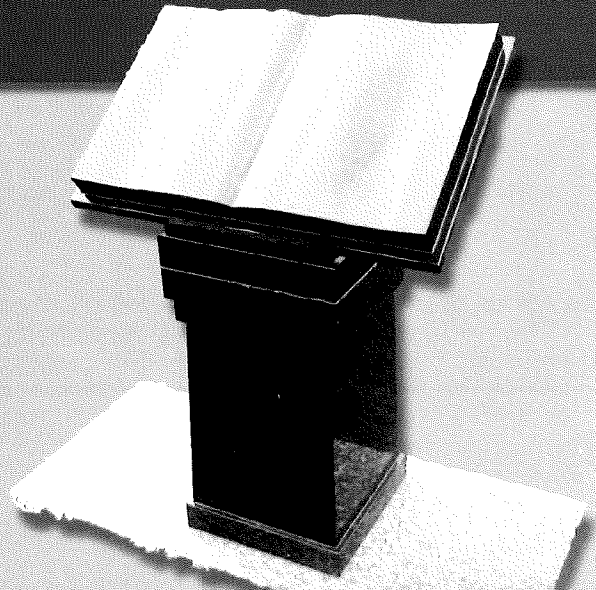

SunburstMemorials.com





# Columbarium Information

Customer may supply their own foundation.

Pricing does not include carve/letter/etch of the niche covers (Pricing per Niche is below)

Cemetery: dictate size, location, costs

All Pricing: Grey Trim with Jet Black Door Covers

Add: \$300 per to carve/letter a niche cover

Add: \$500 per to etch a niche cover

# Columbarium Information

## 24 Niche Rectangle

Retail: \$18,500

Freight & Setting (location & fuel rates will vary) ~ \$ 3000-4000

Foundation Estimate: \$6,000

Crane Estimate: \$ 1000

Wt: 3654 lbs.

24 Niche Rectangle

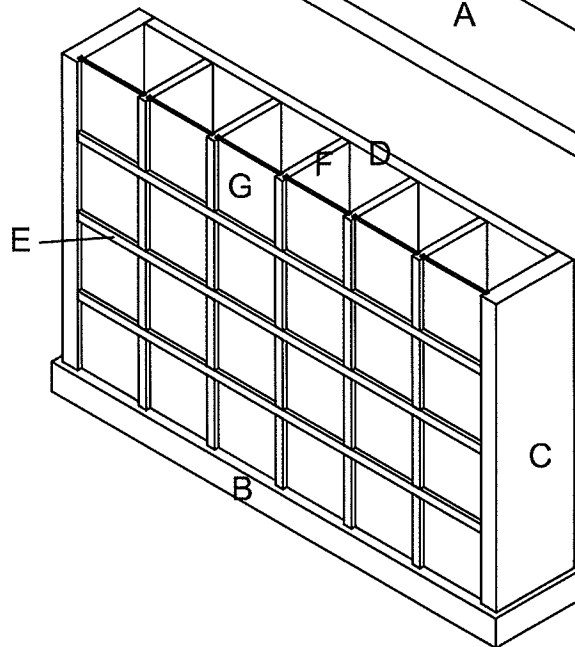
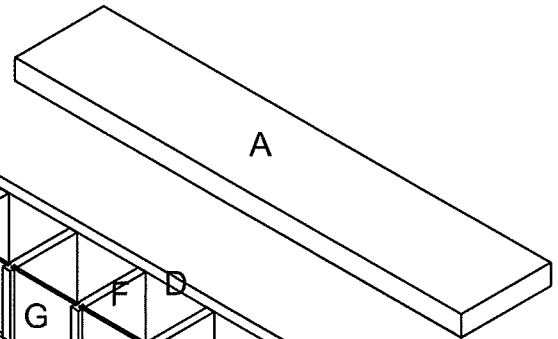
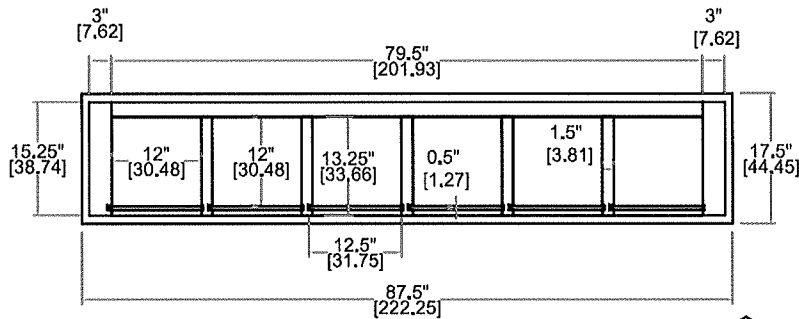

SLAB	SIZE			PCS	M3
	L"	W"	H"		
A	87.5	17.5	4	1	0.100
B	87.5	17.5	5	1	0.125
C	3	15.25	52.5	2	0.079
D	79.5	2	52.5	1	0.137
E	79.5	13.25	1.5	3	0.078
F	1.5	13.25	12	20	0.078
G	12.5	0.5	12	24	0.029
<b>TOTAL</b>	2020/3/20			52	0.627



**Consumer cost per niche (cost of single grave space) \$1200**

24 x \$1200 : \$28,800

Open/Close \$300 each x 24 = \$7200

# Columbarium Information

## 32 Niche Rectangle

Retail: \$23,600

Freight & Setting

Freight & Setting (location & fuel rates will vary) ~ \$ 3000-4000

Foundation Estimate: \$

Crane Estimate: \$

Wt. 3843 lbs.

32 Niche Rectangle

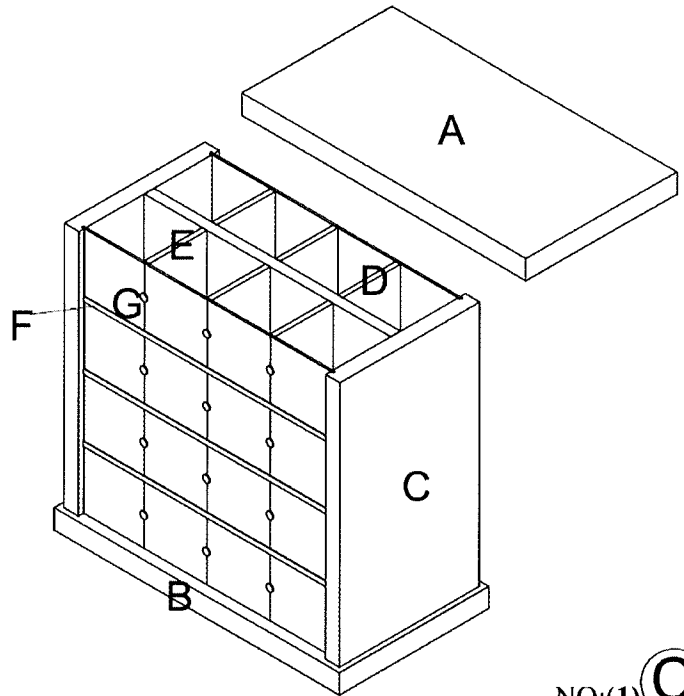
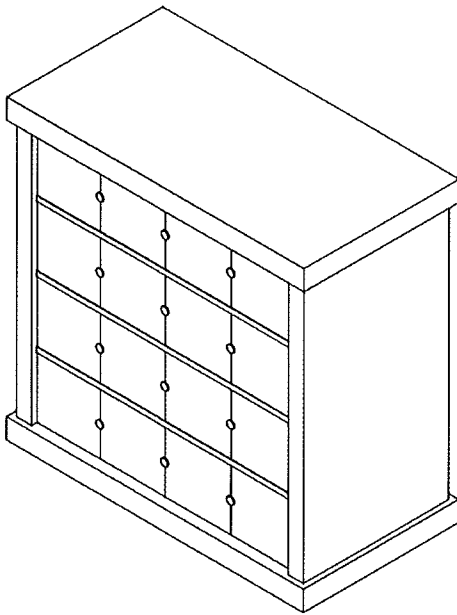

SLAB	SIZE (英寸)			PCS	M3
	L"	W"	H"		
A	59	31	4	1	0.120
B	59	31	4	1	0.120
C	29	3	51	2	0.145
D	51	2	51	1	0.085
E	12	1	12	24	0.057
F	51	12.5	1	6	0.063
G	13	0.4	12	32	0.033
TOTAL	2019/12/10			67	0.622

NO:(1) ©

**Consumer cost per niche (cost of single grave space) \$1200**

**32 x \$1200 : \$38,400**

# Columbarium Information

## 32 Niche Octagon

Retail: \$24,500

Freight & Setting (location & fuel rates will vary) ~ \$ 3000-4000

Foundation Estimate: \$

Crane Estimate: \$

Wt. 3160 lbs.

32 Niche Octagon

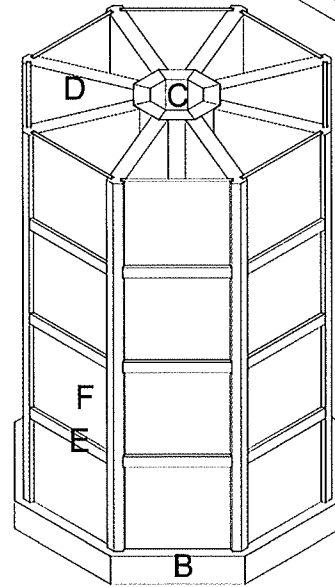
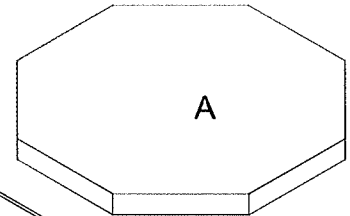
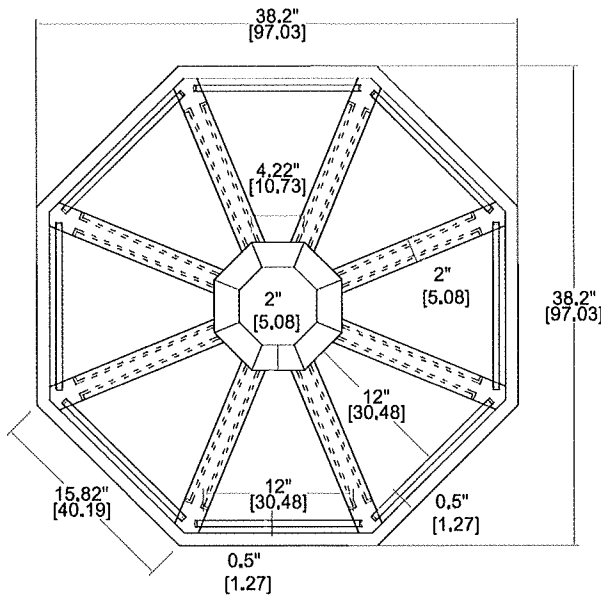

SLAB	SIZE			PCS	M3
	L"	W"	H"		
A	38.2	38.2	3	1	0.072
B	38.2	38.2	4	1	0.096
C	4.22	2	52.5	8	0.058
D	2	14.5	52.5	8	0.200
E	12.83	13	1.5	24	0.098
F	13	0.5	12	32	0.041
<b>TOTAL</b>	2022/10/20			74	0.564



**Consumer cost per niche (cost of single grave space) \$1200**

**32 x \$1200 : \$38,400**

# Columbarium Information

## 48 Niche Rectangle

Retail: \$31,500

Freight & Setting (location & fuel rates will vary) ~ \$ 3000-4000

Foundation Estimate: \$

Crane Estimate: \$

Wt. 8076 lbs.

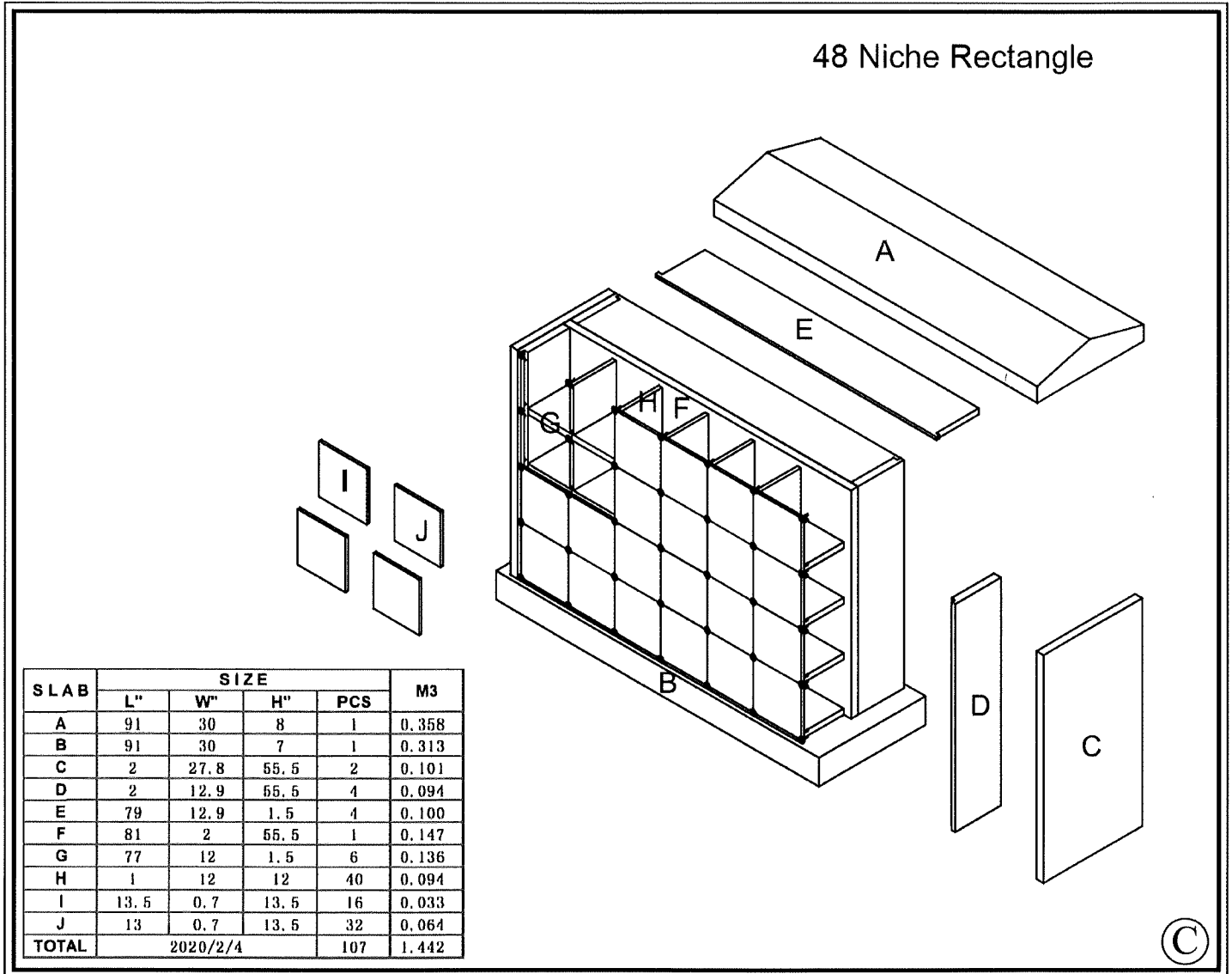

Consumer cost per niche (cost of single grave space) \$1200

32 x \$1200 : \$38,400

# Columbarium Information

## 64 Niche Rectangle

Retail: \$39,950

Freight & Setting (location & fuel rates will vary) ~ \$ 3000-4000

Foundation Estimate: \$

Crane Estimate: \$

Wt. 10,450 lbs.

64 Niche Rectangle

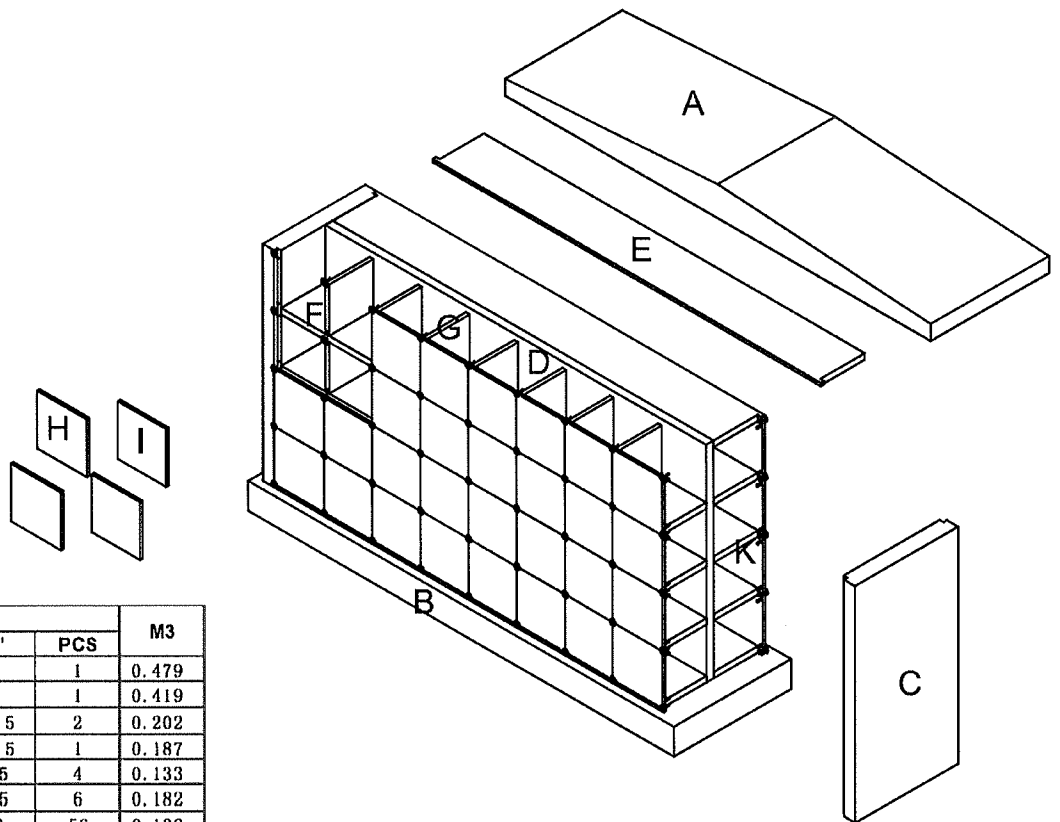

SLAB	SIZE				M3
	L"	W"	H"	PCS	
A	115	31.8	8	1	0.479
B	115	31.8	7	1	0.419
C	4	27.8	55.5	2	0.202
D	2	103	55.5	1	0.187
E	105	12.9	1.5	4	0.133
F	103	12	1.5	6	0.182
G	1	12	12	56	0.132
H	13.5	0.7	13.5	16	0.033
I	13	0.7	13.5	48	0.097
<b>TOTAL</b>	2020/2/4			135	1.866



Consumer cost per niche (cost of single grave space) \$1200

64 x \$1200 : \$76,800

# Columbarium Information

## 72 Niche Rectangle

Retail: \$43,100

Freight & Setting (location & fuel rates will vary) ~ \$ 3000-4000

Foundation Estimate: \$

Crane Estimate: \$

Wt. 11,570 lbs.

72 Niche Rectangle

SLAB	SIZE				M3
	L"	W"	H"	PCS	
A	128	31.8	8	1	0.534
B	128	31.8	7	1	0.467
C	4	27.8	55.5	2	0.202
D	2	116	55.5	1	0.211
E	118	12.9	1.5	4	0.150
F	116	12	1.5	6	0.205
G	1	12	12	64	0.151
H	13.5	0.7	13.5	16	0.033
I	13	0.7	13.5	56	0.113
<b>TOTAL</b>	2020/2/4			151	2.066

©

Consumer cost per niche (cost of single grave space) \_\_\_\_\_ \$1200

72 x \$1200 : \$86,400

# Columbarium Information

## 72 Niche Hexagon

Retail: \$45,500

Freight & Setting (location & fuel rates will vary) ~ \$ 3000-4000

Foundation Estimate: \$

Crane Estimate: \$

Wt. 13,080 lbs.

72 Niche Hexagon

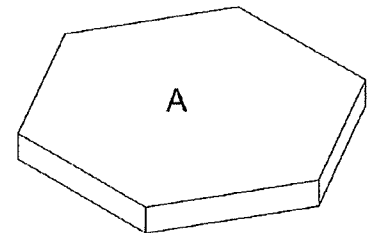

SLAB	SIZE			PCS	M3
	L"	W"	H"		
A	68.36	59.2	6	1	0.398
B	68.36	59.2	6	1	0.398
C	16.11	2	79.5	6	0.252
D	4.33	17.43	79.5	6	0.590
E	28.02	14.65	1.5	30	0.303
F	1.5	14.65	12	36	0.156
G	12.6	0.5	12	72	0.089
H	13.4	0.8	12	72	0.152
TOTAL	2020/7/7			224	2.337

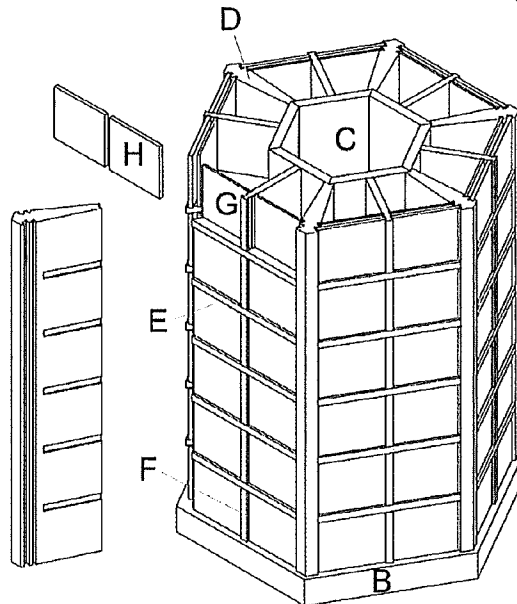

©

**Consumer cost per niche (cost of single grave space) \$1200**

**72 x \$1200 : \$86,400**

# Columbarium Information

## 96 Niche Octagon

Retail: \$69,000

Freight & Setting (location & fuel rates will vary) ~ \$ 3000-4000

Foundation Estimate: \$

Crane Estimate: \$

Wt. 23,640 lbs.

96 Niche Octagon

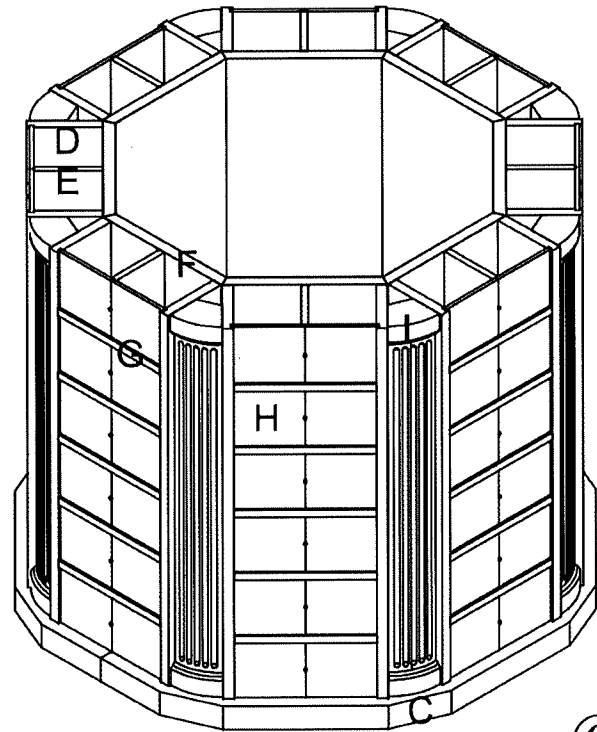
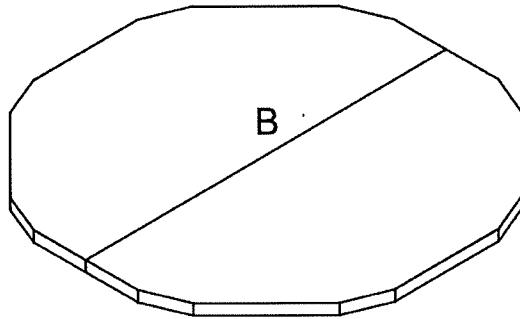

SLAB	SIZE				M3
	L"	W"	H"	PCS	
B	102	51	3	2	0.511
C	102	51	5	2	0.852
D	13.25	2	79.5	16	0.552
E	12	1.25	12	48	0.142
F	29.25	2.25	79.5	8	0.686
G	26.25	13.25	1.5	40	0.342
H	13.25	0.75	12	96	0.188
I	9.87	7	79.5	8	0.720
TOTAL	2019/6/20			220	3.993



Consumer cost per niche (cost of single grave space) \$1200

96 x \$1200 : \$115,200



# MEMORANDUM

TO: Blair Parks, Recreation, and Cemetery Board  
From: CJ Heaton, Deputy City Administrator of Public Works  
Date: 10/21/25  
Re: Proposed Changes to Cemetery Rules: Number of Cremains per Space

Staff have proposed a rule change to allow more than two cremations per grave space in the Blair Cemetery. Currently, rules permit one casket and one cremation, or two cremations, per space. Families have asked staff to allow for more than two cremations per space. Staff propose changing the rule to allow for 6 cremations per space. We do not recommend changing the rules regarding headstones, and families will have to understand that, in some cases, a stone or memorial may not be allowed due to space restrictions.

**Staff Recommendation:** Seeking opinion and possible action.

**Financial Impact:** NA

## FOREWORD

The Blair Cemetery is owned and managed by the City of Blair, Nebraska.

The management of the cemetery shall be under the direction of the Cemetery and Parks Supervisor, who in turn shall be responsible to the Deputy City Administrator of Public Works, City Administrator, Blair Mayor, and City Council for direct and complete supervision of the cemetery in all matters.

All applications for purchase, transfers, assignments or repurchase of the cemetery grave spaces, interment and disinterment permits shall be made at the Cemetery and Parks Supervisor's Cemetery and Parks Supervisor office. Only the Cemetery and Parks Supervisor Clerk/Treasurer is empowered to receive all monies or payments and to issue receipts for the same in all transactions involving cemetery property or service.

It is the desire of the City to make the Blair Municipal Cemetery a quiet, beautiful place for the deceased, where a sense of repose will be obtained by dignified landscape effects on a well-maintained lawn. Anything which would mar the general beauty and harmony of the cemetery must be avoided. Peace and good order must prevail, and the sacredness of the cemetery must be properly maintained. It is to this end that these rules and regulations have been implemented.

These rules govern the use and operation of the Blair Cemetery located in Blair, Washington County, Nebraska.

## **ARTICLE 1 GENERAL RULES**

1. The cemetery is open every day of the year, weather permitting. The gates are open from 7:00 a.m. to dusk.
2. The Cemetery and Parks Supervisor may open or close the Cemetery when in his judgment the appropriate use of the cemetery requires it.
3. The Cemetery and Parks Supervisor has the general oversight of the cemetery and shall coordinate the time and day of all interment and disinterment.
4. No person shall:
  - a. Operate a motor vehicle within the cemetery except on an established roadway.
  - b. Disturb any trees, shrubs, plants, or monuments without the consent of the Cemetery and Parks Supervisor.
  - c. Erect a marker, monument, or vase without first contacting the Cemetery and Parks Supervisor and obtaining the necessary authorization and/or permits.
  - d. Erect a mausoleum for private use.
5. The Cemetery and Parks Supervisor and/or City Council reserves the right for City workers and those persons necessary to the performance of normal cemetery operations to enter on or cross over any lot or grave space in the cemetery in performing such duties as are deemed necessary by the Cemetery and Parks Supervisor of the Blair Cemetery.
6. The Blair Cemetery and/or City of Blair shall not be financially responsible for any damage to grave spaces, monuments, vases, or structures thereon for flowers or articles removed from any grave space or lot.
7. Neither the City of Blair nor its employees assumes liability for property or physical damage, or mental anguish caused or alleged to be caused in the performance of normal operations or of loss or damage by vandals or any third party.
8. All traffic rules of the City of Blair shall apply to operations of vehicles in the Blair Cemetery. No vehicle shall be operated more than ten miles per hour within the cemetery. Any person driving in the cemetery shall be responsible for any damage done by the vehicle, and/or the person operating such vehicle.
9. The City Council shall have the right at any time to amend or change these rules and regulations.

**ARTICLE 2**  
**INTERMENTS, DISINTERMENTS, AND REMOVALS**

1. Any interment, disinterment, and or removal in or from the cemetery are subject to these rules and the Statutes of the State of Nebraska
2. The Cemetery and Parks Supervisor shall be given a minimum of twenty-four (24) hours' notice in the Summer and thirty-six (36) hours' notice in the Winter for the opening and preparation of a grave prior to interment.
3. Interments on Saturday, or City-recognized holidays, shall be allowed for religious reasons, extraordinary, or extenuating circumstances. Sunday funerals shall only be allowed for religious reasons and shall be charged at the Saturday afternoon or City holiday rate.
4. Any disinterment and or removal shall be made under the direction of the Cemetery and Parks Supervisor according to the laws of the State of Nebraska, Washington County, the State Board of Health, and in the presence of a Licensed Mortician.
5. Disinterment or removal will not be permitted on weekends, National or City-recognized holidays.
6. The Cemetery and Parks Supervisor shall be given at least one week notice of the intention to disinter or remove a body from the cemetery. When disinterment is made, the Cemetery and Parks Supervisor shall permit only the following persons to be present:
  - a. Members of the immediate family.
  - b. The mortician conducting the disinterment.
  - c. A legal enforcement official authorized by a Court Order.
  - d. Any other person specifically authorized by Law or Court Order.
  - e. Any other person(s) that are needed to perform disinterment and/or re-interment.
7. The interment of two bodies in one grave space will not be permitted except in the following cases:
  - a. Two infants
  - b. One infant and one cremation.

- c. One cremation and one adult burial (where sufficient space is available).
    - i. Cremations will only be placed on top of the vault or box.
  - d. Multiple cremations (based on available space)?
    - i. Up to 6 cremations allowed per grave space.
  - e. One adult and one infant.
8. No interment of remains other than that of a human being will be permitted within the cemetery.
  9. All interred cremains shall meet all Cemetery rules and regulations for lot setback, lot coverage, and shall be placed in conformance with regulations for monuments and markers.
  10. No interment will be permitted until the Cemetery and Parks Supervisor has issued a burial permit and all requirements have been met and all fees paid to the City Clerk/Treasurer.
  11. The lot owner and/or funeral director shall designate the location of graves on the lot to the Cemetery and Parks Supervisor, and any change of location made after the opening of the grave has begun shall be at the expense of the lot owner/funeral director. When definite information for locating a grave is not available in ample time for grave preparation to meet the time requested for interment, the Cemetery and Parks Supervisor will exercise his best judgment in establishing the location in order that the requested time for interment may be met. The City, Blair Cemetery, or its employees assumes no responsibility for any error in such location. An additional charge will be made for any change requested.
  12. The City and its employees shall not be held responsible for any orders given by phone, or for any mistake resulting from the lack of precise and proper instructions as to the space, size, or location in a plot where an interment is desired.
  13. The cemetery shall be in no way liable for any delays in the interment of a body where a protest to the interment has been made or where the rules or regulations have not been followed. The City shall be under no duty to recognize any protest to interment unless they are in writing and filed at the cemetery.
  14. The Cemetery and Parks Supervisor or his/her designated representative is to be present in the cemetery for every interment or disinterment.
  15. All interments shall be contained in a concrete box or vault only, except for infants or cremation interment, in which case an infant interment may use a fiberglass casket vault combination

16. Disinterment by heirs of a body so that the grave space or lot may be sold for profit to themselves or to any other persons, or disinterment contrary to the written directions of the original grave space or lot owner, shall not be allowed.
17. The City of Blair and/or its employees shall not be liable for any damages to any casket, vault, or box incurred in making a removal. Fee charges for such service are set in Appendix B.

### **ARTICLE 3**

#### **Blocks, Lots, and Grave Spaces**

1. The cemetery is divided into blocks, which are in turn subdivided into lots, each ranging from four (4) to twelve (12) grave spaces. An infant's section and a county burial section are also available in the Blair Cemetery.
2. All arrangements to purchase a lot or grave space shall be coordinated with the Cemetery and Parks Supervisor, after which the purchaser shall make payment to the City of Blair for such purchase. The purchaser shall receive a Cemetery Deed from the City of Blair for the lot or grave spaces purchased. A purchaser acquires no right, title, or interest and may not inter a body or cremation in any grave space in the cemetery; until he has paid in full for said grave space or spaces, along with all interment fees.
3. The City of Blair will file with the Washington County Register of Deeds on behalf of the lot owner. A fee of ten dollars will be added to the sale of lots for this service.
4. A lot owner may sell their grave space or spaces; however, the City shall have no obligation to recognize the transfer unless a copy of the deed recorded with the Registrar of Washington County is filed with the City Clerk. All grave spaces sold back to the Cemetery/City must be conveyed by Warranty Deed.
5. The Cemetery shall have the right to refuse to consent to a transfer or any conveyance of said grave spaces if there is any kind of indebtedness due to the cemetery by a recorded lot or grave space owner.
6. If there are no heirs at law of a lot owner and he or she has not provided by will for the disposal of lots, the remaining space, or spaces, escheat back to the Blair Cemetery after normal inquiry of any known relatives and in accordance with State law.
7. A single interment may not be buried to occupy more than one grave space without written direction from the lot owner or his heirs.
8. Unused grave spaces may be reclaimed and sold per Nebraska State Statute.

**ARTICLE 4**  
**Care of the Cemetery**

1. All grading, general landscape work, improvements, all openings and closing of graves, and all interments, disinterment, and removals shall be made by the Cemetery and Parks Supervisor or an approved delegate.
2. All plantings of trees, shrubs, bushes, plants, and flowers shall be under the direction of the Cemetery and Parks Supervisor; any removal or pruning of the above-listed items must also be under the Cemetery and Parks Supervisor's supervision. The Cemetery and Parks Supervisor may remove any unauthorized planting, and the City and its employees shall not be liable for such removals.
3. Floral arrangements and designs, flowers, shrubs, trees, weeds, or any herbage or any plastic or any other item may be removed by the Cemetery and Parks Supervisor or his employees whenever he judges them to be unsightly, dangerous, detrimental, diseased, or distracting from the general décor of the cemetery. The cemetery and its employees shall not be liable for flower pieces, baskets, frames, or other objects left for or after a funeral service or for decoration of a grave over winter. The cemetery shall not be liable for lost, misplaced, or otherwise damaged flower cases unless such damage is caused by the cemetery personnel in the performance of their duties. The cemetery shall not be responsible for frozen plants or herbage of any kind, or for plantings or herbage of any kind, or for plantings damaged by the elements, drought, lack of water, thieves, vandals, or by other causes beyond its control.
4. Glass containers of any kind are not permitted in the cemetery. The City/cemetery is not responsible for any cost of replacement or injury because of such containers.
5. Flowers (silk, plastic, or real) are not permitted on lots or grave spaces from April 1 through November 1 unless contained in a permanent type of container approved by these rules, except as follows:

- a. From April 1 through November 1, all other decorations or mementos are permitted if attached to the headstone or firmly sitting completely on the headstone base.
  - b. A valid three (3) day registration in remembrance of birthdays or the date of death.
  - c. Five (5) days before Memorial Day to seven (7) days after.
  - d. The Thursday before Mother's and/or Father's Day at 4:00 p.m. to the Tuesday after Mother's and/or Father's Day at 6:00 p.m.
  - e. Temporary decorations are allowed for 30 days after interment. Decorations must be placed in line with adjacent markers and must not impede the routine maintenance of the cemetery.
    - i. An extension may be allowed by the Cemetery and Parks Supervisor on a case-by-case basis, depending upon circumstances.
6. Patrons of the Blair Cemetery may decorate grave spaces or lots from November 1 through April 1 with any items they wish except for any glass items. The cemetery and its employees, however, are not responsible for any items that have been moved, damaged, or lost during this time, either in the performance of their duties or by other third parties.
  7. Patrons of the Blair Cemetery may water grave spaces, lots, trees, and bushes or flowers only if they are present. Any water hydrant left on, and no one present, shall be turned off, and the cemetery employees shall pick up any hoses or sprinklers left out. The cemetery also reserves the right to turn off or disconnect the water supply at any time because of leaks or rationing mandated by the City.
  8. Curbing, fences, or hedges around any grave space or lots are prohibited.
  9. No elevated mounds shall be built over graves, and no lots shall be filled above the level established by the cemetery.

**ARTICLE 5**  
**Monument and Marker Regulations**

1. Flower vases, allowed by these rules, separate from the headstone or monument, must be placed at the North and South ends of the foundation.
2. The Blair Cemetery may charge a fee to the lot owner or person requiring the movement of a large monument or marker or to open a grave. The City is not responsible for the replacement of any foundation damaged by opening a grave.
3. All permits and fees shall be paid before any monuments, markers, vase or foundation work can begin. See Appendix A for any fees.
4. The foundation for any monument or markers shall be level with the ground at least six (6) inches thick. The lot owner is responsible for the maintenance and repairs of the foundation.
5. All monuments or markers shall be no more than sixteen inches in width and be set in a straight line with lot lines. Cemetery staff will locate corner pins and identify the location of each monument or marker. All monuments and markers must be properly aligned in their respective lots.
6. All monuments or markers shall be constructed of marble, granite, or bronze. Rock, steel, aluminum, or formed concrete plate shall not be used for markers or monuments. Grave slabs are not permitted in any part of the cemetery.
7. Monuments or markers shall not be removed unless notice has been given to the Cemetery and Parks Supervisor in writing.
8. Placement of monuments and markers applies to each section of the Cemetery as follows:
  - a. Blocks 1 through 109 inclusive shall have unrestricted monument privileges, which permit the erection of monuments or markers at either or

both ends of a grave space that do not interfere with future grave openings and are not set back-to-back with another monument or marker.

- b. Blocks 110, 111 and 118, the monuments or markers on the East one-half of the lot shall be placed on the East end of the grave with the inscription facing the grave, and on the West one-half of the lot, the monuments or markers shall be placed on the West end of the grave with the inscription facing the grave.
  - c. Block 115-117 shall allow monuments or markers on the East one-half of the lot shall be placed on the East end of the grave with the inscription facing the grave, and on the West one-half of the lot, the monuments or markers shall be placed on the West end of the grave with the inscription facing the grave..
  - d. Monuments or markers located in North-South closed roadway lots shall be placed at the West end of the grave and face East. No monuments may be placed on the east end of these grave spaces.
  - e. Center (Family) monuments will not be permitted in any section of the cemetery for lots purchased after April 1, 2023.
9. In the event existing curbs become a maintenance hazard or become unsightly because of deterioration and/or disrepair, the Cemetery and Parks Supervisor shall notify the lot owner or heirs, if possible, that the curb must be repaired within 30 days, weather permitting, or it shall be removed. If no lot owner or heir can be located, the Cemetery shall repair or remove the curbing at the Cemetery and Parks Supervisor's discretion.
10. Spaces will multiple burials will not be exempt from the head stone rules and regulations.
11. The following requirements shall apply to all monuments and markers:
- a. Only professional monument companies are permitted to install foundations and monuments.
  - b. Only engineered, pre-stressed precast concrete foundation caps set in a wet concrete footing will be used.
    - i. The monument company will be responsible for determining the depth of the footing.
    - ii. Monuments over sixty (60) inches tall must be supported by a minimum six-inch-thick foundation and a six-inch diameter post forty-two (42) inches deep, one for each two feet of length. A reinforcing rod must be used to tie the foundation to the post(s).
  - c. The wash on all monuments will be a minimum of two inches.

- d. No monument, marker, or vase will extend beyond the boundary of the grave space or lot.
- e. It shall be the responsibility of the monument company and/or the family of the deceased to straighten the monument or marker should it begin to lean or tilt.
- f. If, in the judgment of the Cemetery and Parks Supervisor, any marker or monument becomes hazardous, the monument company will be notified.
  - i. If the monument company fails to take action after thirty days, the Cemetery and Parks Supervisor may remove the marker until it can be reset.
- g. Temporary markers may be placed by request for a length of 90 days. These may be placed by the funeral home or one provided by the cemetery. After 90 days, temporary markers will be removed, and a permanent marker or monument must be placed at the grave.
  - i. An extension may be allowed by the Cemetery and Parks Supervisor on a case-by-case basis, depending upon circumstances.

**ARTICLE 6**  
**Fees - Charges - Permits - Payments**

The payment of all fees, charges, permits, and payments is payable at the time of service and shall be made at the City Clerk's office, located at 218 South 16<sup>th</sup> Street.

A schedule of all fees, charges, permits, and payments as established by the City Council and stated in Appendix A hereto shall be on file in the office of the Cemetery and Parks Supervisor and in the Blair City Clerk's office. Such a schedule may be amended from time to time.

The City may buy back grave spaces at the rate of \$200.00 per grave space.

**APPENDIX A**  
**Fee Schedule**

Grave Openings

Adult	\$550.00
Infant	\$350.00
Cremation (one urn)	\$300.00
Cremation (one urn with vault)	\$350.00

There shall be an additional charge of \$350.00 for interments on Saturday mornings. There shall be an additional charge of \$350.00 for interments on Saturday afternoon or recognized City holidays. There shall be a late service fee of \$125.00 per hour for any service scheduled after 4 pm.

All disinterments and re-interments in the same grave shall be charged for one (1) opening and any additional time or equipment used in the removal of said disinterment in accordance with City rental fees and expenses.

Any disinterment and re-interment, in another grave, shall be charged for two (2) openings plus any additional fees if applicable.

**Grave Space Purchases**

40- & 45-Inch Spaces	Adult/Infant/Cremation	\$550.00
----------------------	------------------------	----------

**Baby Section (30inches x 60inches)**

Infant (under 2)	\$300.00
Cremation (Any)	\$300.00
Recording Fee for Deed	\$10.00

# MEMORANDUM

TO: Blair Parks, Recreation, and Cemetery Board  
From: CJ Heaton, Deputy City Administrator of Public Works  
Date: 10/21/25  
Re: Proposed Changes to Cemetery Rules: Number of Cremains per Space

Staff have proposed a rule change to allow more than two cremations per grave space in the Blair Cemetery. Currently, rules permit one casket and one cremation, or two cremations, per space. Families have asked staff to allow for more than two cremations per space. Staff propose changing the rule to allow for 6 cremations per space. We do not recommend changing the rules regarding headstones, and families will have to understand that, in some cases, a stone or memorial may not be allowed due to space restrictions.

**Staff Recommendation:** Seeking opinion and possible action.

**Financial Impact:** NA



[americandiscgolf@gmail.com](mailto:americandiscgolf@gmail.com)  
(402)813-5018

---

Proposed changes to Black Elk Neihardt Park Disc Golf Course.

Hole #1 - Moving of both "A" and "B" tees. Pouring new 4' x 12' tee pads. Also the installation of a new "A" pin placement.

Hole #2 - Moving of both "A" and "B" tees. Pouring new 4' x 12' tee pads. Also the installation of a new "B" pin placement.

Hole #3 - Moving of both "A" and "B" tees. Pouring new 4' x 12' tee pads. Also the installation of new "A" and "B" pin placements.

Hole #4 - Moving of both "A" and "B" tees. Pouring new 4' x 12' tee pads. Also the installation of new "A" and "B" pin placements.

Hole #5 - The installation of new "A" and "B" pin placements.

Hole #6 - Moving of both "A" and "B" tees. Pouring new 4' x 12' tee pads. Also the installation of a new "A" pin placement.

Hole #7 - Moving of both "A" and "B" tees. Pouring new 4' x 12' tee pads. Also the installation of new "A" and "B" pin placements.

Hole #8 - The installation of new a "B" pin placement.

Hole #9 - Moving of both "A" and "B" tees. Pouring new 4' x 12' tee pads. Also the installation of new "A" and "B" pin placements.

The proposed changes will help with both course flow and play. Making the course a better experience for players of all skill levels and ages. They will also help by making the course easier to maintain. The safety of both players and the general public has also been a factor in the current proposed changes. Putting more space between holes and keeping pin placements far enough away from playground equipment and the new dog park.

This proposal does not include the removal of the exiting tee pads. We can generate another bid that would include the price of removal of the old pads.

Black Elk Neihardt Park Disc Golf Course is a beautiful place to play. It is an honor to have the chance to make the course even better for everyone to enjoy. The goal of our company is to make our sport accessible to everyone. No matter what age or level of play.





5513 N. 81<sup>ST</sup> STREET  
 OMAHA, NE 68134  
 PHONE: 402.813.5018

**Date:** 9.20.25  
**Submitted to:** City of Blair  
**Project:** Black Elk Neihardt Park Disc Golf Course Renovation

QTY	DESCRIPTION
14	Grading locations in preparation of installation of tees (concrete pads).
	Setting of 12' x 14' forms for tees (concrete pads).
	Pouring and finishing of Tees (concrete pads).
14	Auguring of 10" x 42" holes in preparation of installation of basket sleeves.
	Leveling and setting of basket sleeves.
	<b>TOTAL: \$15,000</b>

**COMMENTS:** This price does not include the removal of old tees(concrete pads). An additional bid can be provided.

To: City of Blair  
 Attn: Mark Hodson  
 Email: 402-533-3740  
 Phone: [mhodson@blairne.gov](mailto:mhodson@blairne.gov)



From: MIDWEST FENCE-GUARDRAIL SYSTEMS INC.  
 8000 Serum Avenue, Ralston, NE 68127  
 Phone (402) 331-3385 / Fax (402) 331-4803

PROPOSAL

Bid Date: October 16, 2025  
 CITY: Blair PROJ.# Dog Park - BLACK VINYL  
 STATE: NEBRASKA

ITEM	DESCRIPTION	QUANTITY	UNIT	TOTAL
002	72" CL fence installed, 2" mesh, 9 gauge core BK <i>-includes 40 weight pipe, 1-5/8" top rail, 2.5" line posts w/ 10"x42" concrete footings</i>	800 LF	\$31.50	\$25,200.00
	Terminal Post Assembly	20 EA	\$190.00	\$3,800.00
	4' Wide x 6'H Gate	3 EA	\$408.00	\$1,224.00
	8' Wide x 6'H Gate	4 EA	\$768.00	\$3,072.00
			<b>Total Bid</b>	<b>\$33,296.00</b>
	<i>Add Bottom Rail</i>	<i>800 LF</i>	<i>\$4.00</i>	<i>\$3,200.00</i>

NOTES:

1. Net 30 days from invoice.
2. Building permit if required by owner.
3. Price good for 30 days.
4. The following items are excluded from our bid grading, filling, Traffic Control, Signs, Permits, Bonds & Dues.
5. If bonding is required add 1 1/2 % to total contract.

**Accepted BY**

**Date**

Information: Trent (Junior) Leonard 402.331.3385 cell 402.981.0667

[tjl@guardrail.omhcoxmail.com](mailto:tjl@guardrail.omhcoxmail.com)





# ELKHORN FENCE CO.

**P.O. Box 186**

**Elkhorn, NE 68022**

**Office 402-289-4945 / Fax 402-289-5566**

To: City of Blair  
  
Attn: Mark Hodson  
CJ Heaton

Date: 10/21/25

Project Name:  
Dog Park

Elkhorn Fence proposes to supply all materials and labor to install 800 LF of 6' tall black coated chain link fence and gates for:

**\$23,225.00 (no tax)**

Clarifications:

- 3" OD SS 40 black powder coated terminal posts set in 10"x39" concrete footings.
- 2" OD SS40 black powder coated line posts set in 19"x39" concrete footings.
- 1-5/8" OD SS20 black powder coated top rails.
- 7 ga black vinyl coated bottom tension wire.
- Standard 2"x9ga. core galvanized/black vinyl coated chain link mesh.
- (3) 4' wide walk gates.
- (2) 16' wide double drive swing gates.

Conditions:

Fence to conform to drawings and written specifications and installed in a professional manner.

**All terminal and corner points to be clearly marked prior to our crew's arrival unless otherwise indicated herein. Fence line location shall be the sole responsibility of the Owner/General Contractor.**

Price includes Mobilizations to site.

Price assumes the entire fence line to be accessible by large skid-steer loader and the ability to dig post holes with hydraulic auger.

Project to be finish graded and ready for all fence installation upon notice to proceed and mobilization to the site.

This proposal to be attached to the Contract/Sub-contract as an Exhibit/Amendment to any Contract upon acceptance.

Price good for **30** days.

Submitted by: Rob Brooks

Accepted By: \_\_\_\_\_

**Rob Brooks**  
402-677-8677 cell

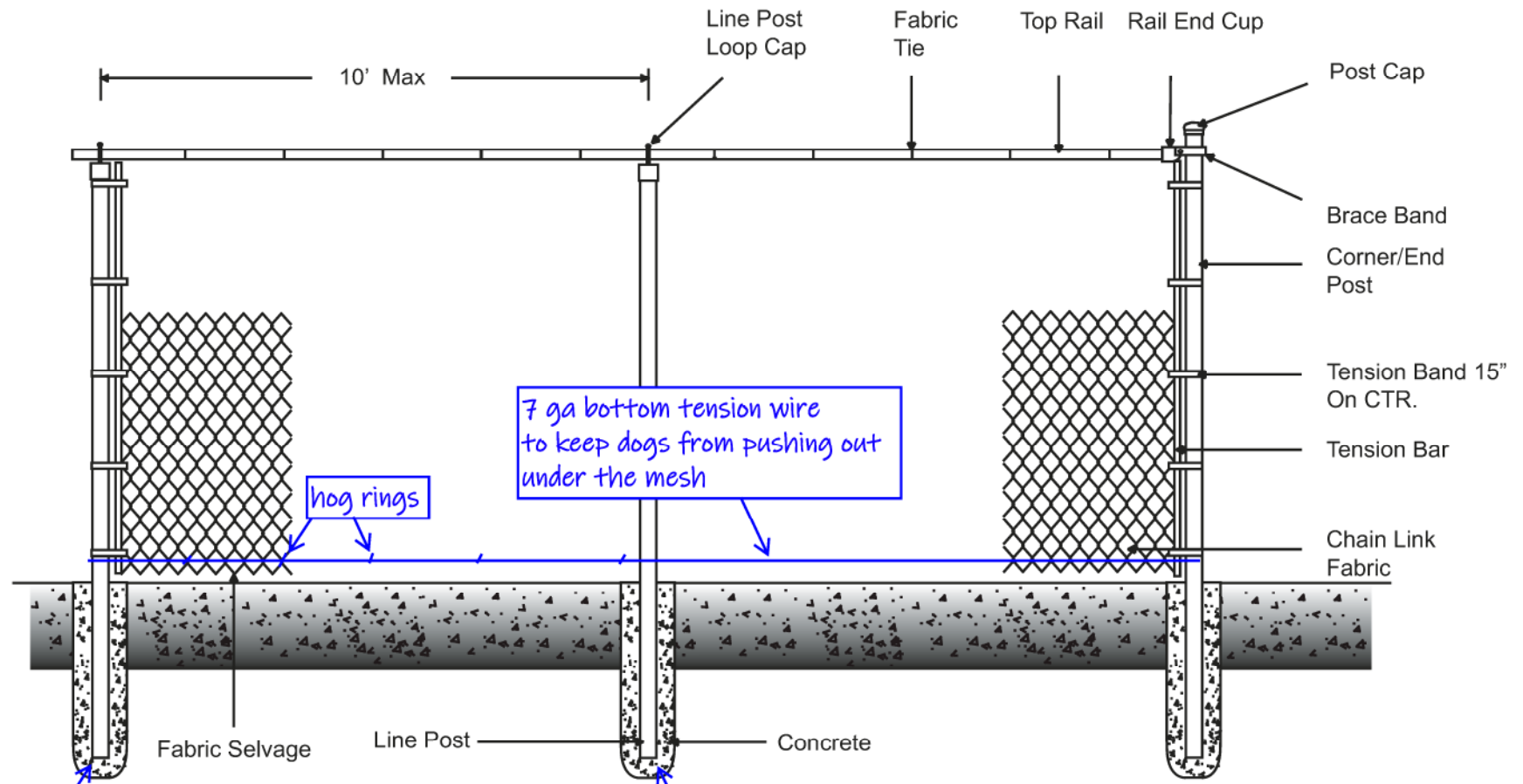

10"x39" concrete footing

9"x36" concrete footing

7 ga bottom tension wire to keep dogs from pushing out under the mesh

hog rings

Top and Bottom

Fabric	Height	Mesh	Gage	Servage	Finish
	6'	2"	9	KK	black
Framework	O.D.	Wall	Wt.per ft.	Length	
End/Corner Post	3"	.149	4.78	9'	
Line Post	2"	.120	2.28	8'	
Rails	1-5/8"	.085	1.46	21'	
Gate Frame	1-5/8"	.085	1.46		
Gate Post	3"	.149	4.78	9'	

- Notes
- Gate Fabric to match fence
  - For welded frames omit truss rods
  - For more information please see <http://www.spsfence.com>

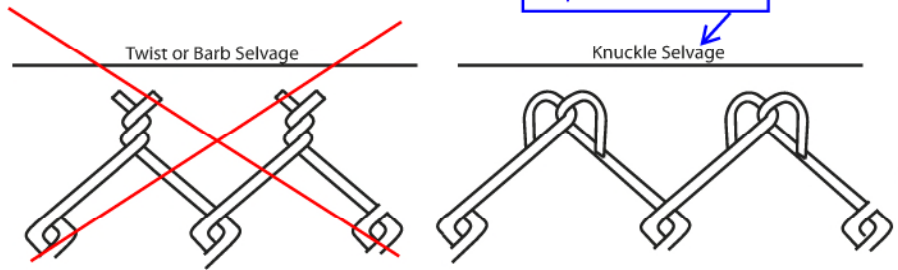

# Standard Chain Link Fencing

## 6' Chain Link Fence W/Top Rail Detail

Approved By: <b>Rob Brooks 10/21/25</b>	Revision NO. <b>4</b>	Drawing NO. <b>SPS-CL-01R2</b>
Drawn By: <b>Joshua Stidham</b>	Effective Date	

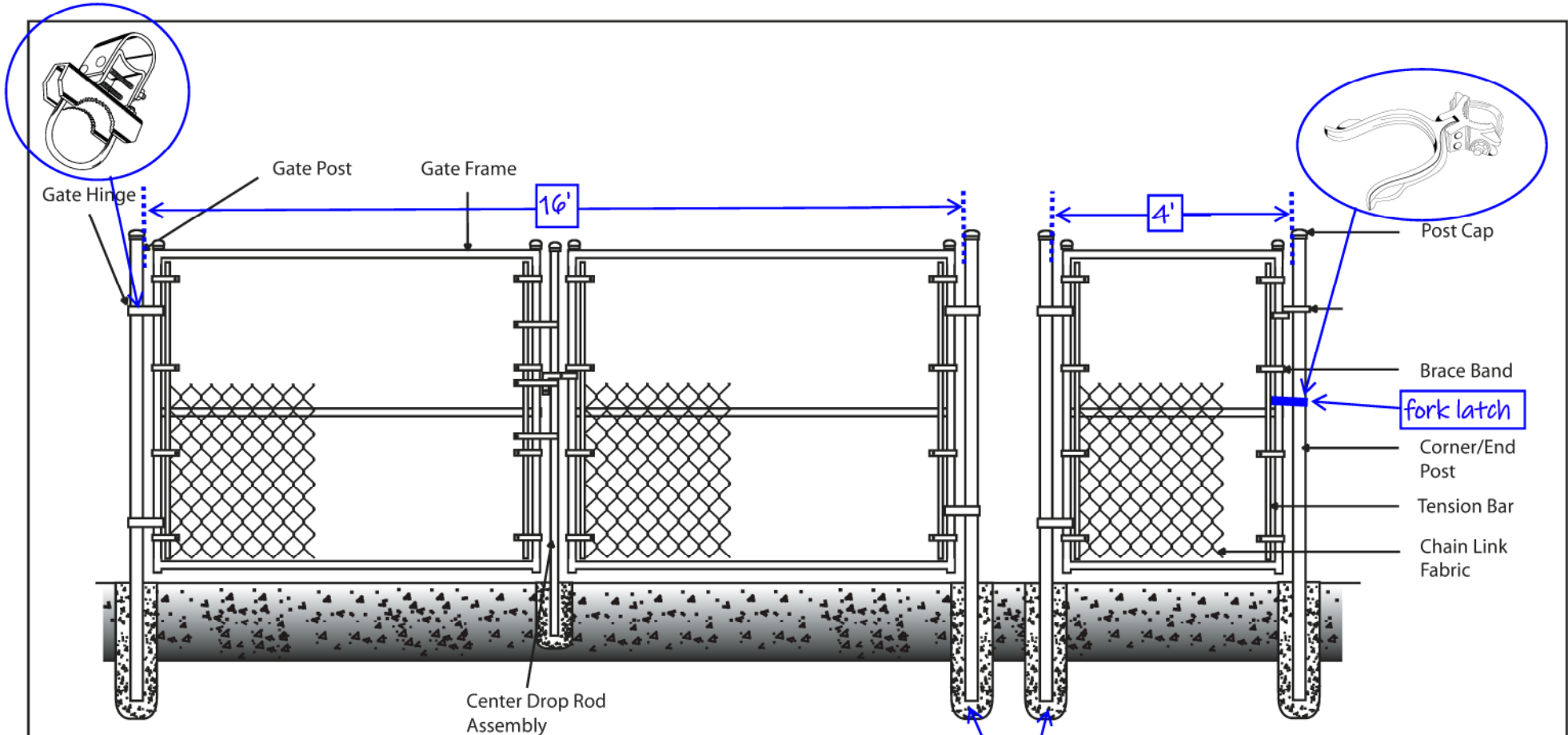

Fabric	Height	Mesh	Gage	Selvage	Finish
	6'	2"	9	KK	black
Framework	O.D.	Wall	Wt. per ft.	Length	
End/Corner Post					
Line Post					
Rails					
Gate Frame	1-5/8	.085	1.46		
Gate Post	3"	.149	4.78	9'	

Notes  
 - Gate Fabric to match fence  
 - For welded frames omit truss rods  
 - For more information please see <http://www.spsfence.com>

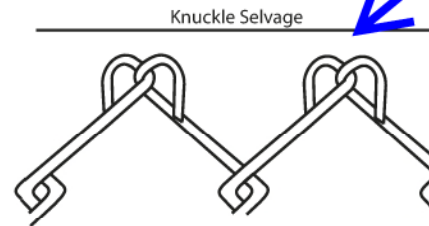
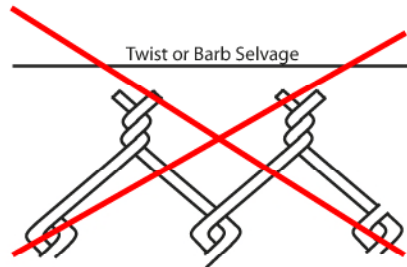

5' Or More



# Standard Chain Link Fencing

Project  
**Standard ChainLink Gate Detail**

Approved By	General Contractor	Drawing NO.
Drawn By: Joshua Stidham	Submitted By: Rob Brooks 10/21/25	SPS-CL-16R2

# MEMORANDUM

TO: Blair Parks, Recreation, and Cemetery Advisory Board  
From: CJ Heaton, Deputy City Administrator of Public Works  
Date: 10/21/25  
Re: Dog Park Fences

Attached are two bids for the dog park fence. The fence will be a black chain link fence, 6 feet high. The sally port will have three gates, one main entrance, and one gate to each section. There will also be two 16-foot gates for mowers and equipment to access the park and water tower. The two bids are as follows.

Midwest Fence - \$33,296.00

Dakota Fence - \$23,613.00

Elkhorn Fence - \$23,225.00

**Staff Recommendation:** Approval and recommendation to the City Council of the bid from Elkhorn Fence in the amount of \$23,225.00

**Financial Impact:** \$23,225.00

TOOLCAT w/ SEEDER



Quotation Number: **DG1434962**

Quote Sent Date: **Oct 01, 2025**

Expiration Date: **Oct 31, 2025**

Prepared By: **Dustin Goodsell**

Phone: 402-510-6993

Email: [dustingoodsell@bobcat-omaha.com](mailto:dustingoodsell@bobcat-omaha.com)

Customer  
**CITY OF BLAIR**  
 218 S 16TH ST  
 BLAIR, NE, 68008-2000  
 Phone: +1 402 426 4191

Contact  
**LOWEL KUBIE**  
 Phone: +1 402 426 4191  
 Email: [lkubie@blairnebraska.org](mailto:lkubie@blairnebraska.org)

Dealer  
**Bobcat of Omaha, Omaha, NE**  
 8701 SOUTH 145TH STREET  
 OMAHA, NE, 68138-3618

Item Name	Item Number	Quantity	Price Each	Total
<b>Bobcat UW53</b>	M1227	1	67,239.00	67,239.00
<b>Standard Equipment:</b>				
Adjustable Vinyl Seats			Falling Object Protective Structure (FOPS) - Meets Requirements of SAE-J1043 & ISO3449, Level I	
All-Wheel Steer			Dome Light	
Automatically Activated Glow Plugs			Interior Trim	
Auxiliary Hydraulics			Joystick, Manually Controlled with Lift Arm Float	
Variable Flow with dual direction detent			Lift Arm Support	
High Flow Hydraulics and Attachment Control Kit			Limited Slip Transaxle	
Beverage Holders			Parking Brake, automatic	
Power Bob-Tach			Power Steering with Tilt Steering Wheel	
Boom Float			Radiator Screen	
Cowl and Cowl Support			Radio:	
Cruise Control			AM/FM/Weatherband	
<b>Deluxe Equipment:</b>			Aux Input & Head Phone Jacks	
Cab Enclosure with Heater and Air Conditioning			Lower Engine Cover	
Deluxe Operator Cab (Front Window, Rear Window, Front Wipers)			Rear Receiver Hitch	
Deluxe Road Package (back-up alarm, turn signals, flashers, tail lights, brake lights, rear view mirror, side mirrors, horn, rear work light, and headlights)			Seat Belts, Shoulder Harness	
Engine and Hydraulic Monitor with Shutdown			Spark Arrestor Muffler	
Front Work Lights			Storage Bins	
Full-time Four-Wheel Drive			Suspension, 4-wheel independent	
Horsepower Management			Tires: 27 x 10.5-15 (8 ply), Lug Tread	
Speed Management			Toolcat Interlock Control System (TICS)	
Instrumentation: Standard 5" Display with Keyless Start, Engine Temperature and Fuel Gauges, Hour meter, RPM and Warning Indicators. Includes maintenance interval notification, fault display, job codes, quick start, and security lockouts.			Two-Speed Transmission	
Heavy Duty Battery			Traction Control	
PTO Package (rear PTO-540 RPM, PTO Shield, PTO Tachometer)			Machine Warranty: 12 Months, unlimited hours	
Three-Point Hitch Package (Three-Point, depth position gauge)			Bobcat Engine Warranty: Additional 12 Months or total of 2000 hours after initial 12 month warranty	
Rear Remote Package (One set of poppet-style couplers, for use with implement hydraulics)				
Roll Over Protective Structure (ROPS) - Meets Requirements of SAE-J1040 & ISO 3471				
<b>29 X 12.5 Turf Tires</b>	M1227-R05-C05	1	753.00	753.00
<b>62" Heavy Duty Bucket</b>	7272678	1	1,180.00	1,180.00

<b>Bolt-On Cutting Edge, 62"</b>	6718005	1	500.00	500.00
<b>72" Seeder</b>	7167712	1	7,130.00	7,130.00
<b>Bob-Tach Adapter - Seeder</b>	7167759	1	666.00	666.00
<b>Electrical &amp; Lighting - Strobe Light Kit</b>	7424783	1	500.00	500.00

Total for Bobcat UW53 77,968.00

Quote Subtotal	77,968.00
Dealer PDI	700.00
Tariff Surcharge	3,977.00
Freight Charges	975.00
Destination Charges	501.00
Dealer Assembly Charges	323.00
Sales Total before Taxes	84,444.00
Taxes	0.00
<b>Quote Total - USD</b>	<b>84,444.00</b>

**Notes:** PRICE PER NE STATE CONTRACT #15993OC AND SOURCEWELL CONTRACT #020223-CEC

<b>Customer Acceptance:</b>	
Quotation Number: DG1434962	Purchase Order: _____
<b>Authorized Signature:</b>	
Print: _____	Sign: _____
Date: _____	Email: _____ Tax Exempt: Y <input type="checkbox"/> / N <input type="checkbox"/>

# MEMORANDUM

TO: Blair Mayor and City Council

From: CJ Heaton, Deputy City Administrator of Public Works

Date: 10/28/25

Re: Purchase of Toolcat for Park Department

The Parks department has in the FY 26 budget funds to purchase a new UTV. Attached is the price for a Toolcat, which is a Bobcat product. This UTV will be used for numerous tasks in the Parks department, from pushing snow to loading dirt and other materials. This piece of equipment can use any attachment that a Bobcat can use, meaning the Parks Department can share implements with other departments, or vice versa. The quote includes a bucket and a seed drill, which can be used for a variety of seeding projects that are currently bid out to a contractor.

**Staff Recommendation:** Approval of the purchase of the ToolCat with the seeder for \$84,444.00. We had \$100,000 budget for this item.

**Financial Impact:** \$84,444.00