

Agenda of Regular Meeting

The Board of Trustees Canutillo ISD

A Regular meeting of the Board of Trustees of Canutillo ISD will be held December 14, 2004, beginning at 6:00 PM in the Canutillo ISD Administration Office, 7965 Artcraft, El Paso, TX 79932.

The subjects to be discussed or considered or upon which any formal action may be taken are as listed below. Items do not have to be taken in the order shown on this meeting notice.

1. General Functions
 - A. Call to Order
 - B. Roll Call
 - C. "Pledge of Allegiance to the United States Flag" 4
 - D. "Texas Pledge of Allegiance" 5
 - E. "CISD Mission Statement" 6
 - F. Approval of Minutes
 1. Regular Board Meeting 11/9/04 7
 2. Special Board Meeting 11/11/04 23
 - G. Communications (Thirty Minute Open Forum)
 1. General Comments Portion
 2. Complaints Portion
 - H. Board of Trustee Business
 1. Review of events for month of December 27
 2. Holiday Melodies Performed by Canutillo High School Choir - Mr. Adame, Choral Director
 - I. Committee Reports
 1. Facilities/Finance Committee - Mr. Coronado, Chairperson 28
(November 29th & December 8)
 - J. Consent Agenda
 1. Leave of Absence Requests
 2. Approval of Budget Amendments
 3. Award Armored Car Service RFP #05-06
 4. Purchase of FFA truck and Band trailer for CHS
 5. Food Service Child Nutrition Cooperative Purchasing Contracts
 6. Furniture and equipment for new high school
 7. Award of E-Rate #8 Projects
 8. Purchase upgrade to enhance the district's SEMS telephone absence tracking system
 9. Interlocal Agreement with Village of Vinton regarding the Safe & Drug Free Schools and Community Grant

10.	Interlocal Agreement with Village of Vinton to share maintenance, personnel and equipment	
11.	Interlocal Agreement with El Paso ISD regarding El Paso County Juvenile Justice Alternative Education Program	
12.	Purchase district-wide extended warranties for servers	
13.	Request permission for use of space in the CISD maintenance facility by West Texas Health Connection	
14.	Request easement for a portion of Tract 8A, Block 11, Upper Valley Grant, El Paso, Texas by El Paso Electric Company	
15.	Board Budget Priorities for Fiscal Year 2005~2006	
16.	Approval of Optometric Services	
17.	Adoption of Policy CW (Local) - New Facilities as recommended by Policy Committee - second reading	
18.	Adoption of TASB Localized Policy Manual Update 73 as recommended by Policy Committee (including Policies GKD (Local) and GKDA (Local)) - second reading	
K.	Reports	
1.	Superintendent's Report	
a.	Overview of 2004	
2.	Financial, Attendance, Warrant List for October 23rd - November 30th 2004 in the amount \$2,515,840.04	30
3.	Other Reports	
a.	Formative Report - DAC - Antonio Del Campo, Chairperson	
b.	Progress Report on Construction of New High School - Dimensions Architects International & Banes General Contractor	
2.	Instruction and Student Affairs	
A.	NONE	
3.	Personnel	
A.	Leave of Absence Requests	33
B.	Request for a Level III Grievance by Jose R. Banuelos	
C.	Administrative Personnel Actions (no Board action required - information item only)	34
1.	Superintendent approved employment of personnel (no Board action required)	
2.	Superintendent approved position changes for personnel (no Board action required)	
3.	Superintendent acceptance of resignations from personnel (no Board action required)	
4.	Termination of Support Personnel (no Board action required)	
4.	Business and Finance	
A.	Approval of Budget Amendments	38
B.	Acceptance of Donations to Canutillo ISD	53
C.	Award Armored Car Service RFP #05-06	57
D.	Purchase of FFA truck and Band trailer for CHS	59
E.	Food Service Child Nutrition Cooperative Purchasing Contracts	61
F.	Furniture and Equipment for new high school	73
G.	Award of E-Rate #8 Projects	74

H.	Purchase upgrade to enhance the district's SEMS telephone absence tracking system	75
I.	Interlocal Agreement with Village of Vinton regarding the Safe & Drug Free Schools and Community Grant	77
J.	Interlocal Agreement with the Village of Vinton to share maintenance, personnel and equipment	83
K.	Interlocal Agreement with El Paso ISD regarding El Paso County Juvenile Justice Alternative Education Program	88
L.	Purchase district-wide extended warranties for servers	94
M.	Request permission for use of space in the CISD maintenance facility by West Texas Health Connections	108
N.	Request for easement for a portion of Tract 8A, Block 11, Upper Valley Grant, El Paso, Texas by El Paso Electric Company	110
O.	Consultation with attorney regarding change order requested by Enlink	
P.	Board Budget Priorities for Fiscal Year 2005~2006	114
Q.	Consider use of artificial turf or natural grass on the new high school football field	
R.	Presentation and possible recommendation to proceed with the issuance of Tax Maintenance Notes for the installation of artificial turf and possibly other capital improvements at the new high school	116
S.	Approval of Optometric Services	124
T.	Consideration of possible solutions regarding the openings on the second floor corridors at the new high school	
5.	Administration	
A.	Adoption of Policy CW (Local) - New Facilities as recommended by Policy Committee - second reading	126
B.	Adoption of TASB Localized Policy Manual Update 73 as recommended by Policy Committee (including Policies GKD (Local) & GKDA (Local)) - second reading	129
6.	Adjournment	

If, during the course of the meeting, discussion of any item on the agenda should be held in a closed meeting, the Board will conduct a closed meeting in accordance with the Texas Open Meetings Act, Government Code, Chapter 551, Subchapters D and E. Before any closed meeting is convened, the presiding officer will publicly identify the section or sections of the Act authorizing the closed meeting. All final votes, actions, or decisions will be taken in open meeting.



Pledge of Allegiance to the United States Flag

***I pledge allegiance to the flag of the United States of America
and to the republic for which it stands:
one nation under God, indivisible,
with liberty and justice for all.***

When reciting the pledge of allegiance, civilians should stand at attention or with the right hand over the heart. Men should remove their hats. Armed services personnel in uniform face the flag and give the military salute.



Texas Pledge of Allegiance

“Honor the Texas Flag; I pledge allegiance to thee, Texas, one and indivisible.”

The pledge of allegiance to the state flag should be rendered by all present except those in uniform by standing at attention facing the flag with the right hand over the heart. Individuals who are not in Uniform and who are wearing a headdress that is easily removable should remove their headdress with their right hand and hold it at the left shoulder, with the hand over the heart. Individuals in uniform should remain silent, face the flag, and render the military salute.

The pledge of allegiance to the state flag may be recited at all public and private meetings at which the pledge of allegiance to the United States Flag is recited and at state historical events and celebrations.

The pledge of allegiance to the state flag should be recited after the pledge of allegiance to the United States flag if both are recited.

Canutillo ISD

Mission Statement

Canutillo Independent School District is committed to providing a quality education to meet the varied needs of its student body. Every learner will have the opportunity to be challenged, successful, and prepared for a future as a responsible and productive citizen.

The District believes that quality education will provide the opportunity....

....to develop the ability to think logically, independently, and creatively.

....to communicate effectively.

....to develop an appreciation for other people.

....to build a responsibility to local, state, national and world communities.

MINUTES
CANUTILLO INDEPENDENT SCHOOL DISTRICT
PUBLIC MEETING OF THE BOARD OF TRUSTEES

MEMBERS

MR. CORONADO	MR. FRIETZE	MR. HECKER	MR. LERMA	MR. REYES	MRS. SANCHEZ	MR. VILLARREAL
--------------	-------------	------------	-----------	-----------	--------------	----------------

Type of Meeting: Special Board Meeting

Location Canutillo ISD Administration Office
 7965 Artcraft - El Paso, Texas

Date: (Tuesday) November 9, 2004 **Time:** 6:05 p.m.

Item:

Reference:

Present

1.0 General Functions

1.1 Call to Order

1.2 Roll Call (Mr. Lerma arrived at 6:06 p.m. during the reciting of the Mission Statement. Mr. Villarreal was absent.)

Mr. Frieze, Vice-President of the Board presided over the meeting.

“Pledge of Allegiance to the United States Flag”

Pg. 1

Mrs. Sanchez led the group in reciting the Pledge of Allegiance.

“Texas Pledge of Allegiance”

Pg. 2

Mrs. Sanchez led the group in reciting the Texas Pledge of Allegiance.

“CISD Mission Statement”

Pg. 3

Mr. Lerma arrived at the public meeting at 6:06 p.m.

Mr. Frieze read the Mission Statement into the record:

Canutillo Independent School District is committed to providing a quality education to meet the varied needs of its student body. Every learner will have the opportunity to be challenged, successful, and prepared for a future as a responsible and productive citizen.

The District believes that quality education will provide the opportunity....

....to develop the ability to think logically, independently and creatively.

....to communicate effectively.

**MINUTES
CANUTILLO INDEPENDENT SCHOOL DISTRICT
PUBLIC MEETING OF THE BOARD OF TRUSTEES**

MEMBERS

MR. CORONADO	MR. FRIETZE	MR. HECKER	MR. LERMA	MR. REYES	MRS. SANCHEZ	MR. VILLARREAL
--------------	-------------	------------	-----------	-----------	--------------	----------------

Item:

Reference:

....to develop an appreciation for other people.
....to build a responsibility to local, state, national and world communities.

1.3 Approval of Minutes

Minutes for the meetings of:
Regular Board Meeting – 10/12/04
Special Board Meeting – 10/20/04
Special Board Meeting – 10/26/04

Pgs. 4-16
Pgs. 17-19
Pgs. 20-21

Motion
Second
Ayes
Nays
Abstain

✓
✓
✓
✓
✓
✓

Motion to approve the minutes of the Regular Board Meeting – October 12, 2004, Special Board Meeting – October 20, 2004 and Special Board Meeting – October 26, 2004, passed.

1.4 Communications (Thirty Minute Open Forum)

1.4.1 General Comments Portion

Dr. John Kessinger, Assistant Superintendent for Administration & Planning, presented to Ernie Ontiveros, Transportation Supervisor, Certificates of Appreciation that were awarded to the Transportation Services staff members in recognition of their efforts in providing students safe rides to and from schools everyday.

Petty Officer First Class Pete Soto, NJROTC Instructor at CHS, extended a public invitation to CHS's annual cadet inspection, which is scheduled for 8:30 a.m. on Tuesday, November 30, at CHS Eagle Stadium.

Regular Board Meeting Minutes 11/9/04 page 2

MINUTES
CANUTILLO INDEPENDENT SCHOOL DISTRICT
PUBLIC MEETING OF THE BOARD OF TRUSTEES

MEMBERS

MR. CORONADO	MR. FRIETZE	MR. HECKER	MR. LERMA	MR. REYES	MRS. SANCHEZ	MR. VILLARREAL
--------------	-------------	------------	-----------	-----------	--------------	----------------

Item:	Reference:
<p>Mrs. Norma Hita, parent, expressed her disappointment at the way the Board handled a recent personnel matter.</p> <p style="text-align: center;">1.4.2 Complaints Portion</p> <p>No member of the audience addressed the Board.</p> <p style="text-align: center;">1.5 Board of Trustee Business</p> <p style="text-align: center;">1.5.1 Review of events for month of November</p> <p>The Board reviewed the Calendar of Events for November. Dr. Padilla informed the Board that the AEIS Report would be delayed until January or possibly February. Dr. Padilla also informed the Board that the DAC Report would be presented in December.</p> <p style="text-align: center;">1.5.2 Report on TASA/TASB Convention Delegate Assembly – Mr. Lerma/Mr. Fietze</p> <p>Frank Lerma and Carl Fietze, CISD Delegates to the TASA/TASB Legislative Assembly, presented a summary report on the assembly that they attended during the recent convention.</p> <p style="text-align: center;">1.6 Committee Reports</p> <ul style="list-style-type: none"> • Facilities/Finance Committee Meeting – Mr. Coronado, Chairperson (October 20 & November 3) <p>Mr. Coronado, Facilities & Finance Committee Chairperson, reported that at the October 20 meeting, the committee reviewed options regarding the track and tennis court surfaces for the new high school and asked for additional information before making a recommendation.</p>	<p>Pg. 22</p> <p>Pgs. 23-25</p> <p>Regular Board Meeting Minutes 11/9/04 page 3</p>

**MINUTES
CANUTILLO INDEPENDENT SCHOOL DISTRICT
PUBLIC MEETING OF THE BOARD OF TRUSTEES**

MEMBERS

MR. CORONADO
MR. FRIETZE
MR. HECKER
MR. LERMA
MR. REYES
MRS. SANCHEZ
MR. VILLARREAL

Item:

Reference:

He said that the Committee also heard a presentation by Rose Dowdy, of Enlink, on the status of geothermal system being installed at the new high school. Mr. Coronado reported that at the November 3 meeting, the Committee reviewed and recommended for approval the Warrant List and Financial Statements for October. He said that the committee received an update report on the new high school construction project. Mr. Coronado said that the Committee also received reports from the District's Construction Administrator regarding the geothermal system and the artificial turf possibilities.

- Personnel Committee Meeting – Mr. Fietze, Chairperson (October 26)

Pg. 26

Mr. Fietze, Personnel Committee Chairperson, reported that at the October 26 meeting, the Committee reviewed and recommended for approval the request for the creation of an IT Technical Support Specialist position in the Technology Department to address the district's growing technological network and programs' demands. He said that the Committee also reviewed and recommended for approval the addition of a market stipend for the Occupational Therapist, which was inadvertently left off the District's Stipend List for 2004-05.

- Policy Committee Meeting – Mr. Hecker, Chairperson (October 26)

Pgs. 27-30

Mr. Hecker, Policy Committee Chairperson, reported that at the October 26 meeting, the Committee reviewed and recommended for approval revisions to Board Policy regarding the naming and re-naming of CISD facilities. Mr. Hecker noted that the policy states that the name of Canutillo Elementary, Canutillo Middle School and Canutillo High School may not be changed regardless of physical location

Regular
Board
Meeting
Minutes
11/9/04
page 4

MINUTES
CANUTILLO INDEPENDENT SCHOOL DISTRICT
PUBLIC MEETING OF THE BOARD OF TRUSTEES

MEMBERS

MR. CORONADO
MR. FRIETZE
MR. HECKER
MR. LERMA
MR. REYES
MRS. SANCHEZ
MR. VILLARRAL

Item:

Reference:

- Instruction & Student Services Committee Meeting – Mr. Reyes, Chairperson (October 19)

Pgs. 31-33

Mr. Reyes, Instruction & Student Services Committee Chairperson, reported that at the October 19 meeting, the Committee reviewed and recommended for approval the Goals and Objectives for District and Campus Improvement Plans, Mr. Reyes said that the Committee also heard a presentation on the District's curriculum development documents and testing program.

1.7 Consent Agenda

- a. 2.2 Recommendation for School Health Advisory Council (SHAC) Membership
- b. 3.1 Creation of Position – IT Technical Support Specialist
- c. 3.5 Leave of Absence Requests
- d. 3.6 Supplemental Assignment-Addition to Stipend List (Occupational Therapist)
- e. 4.1 Budget Amendments
- f. 4.3 Purchase of Copy Paper
- g. 4.4 CISV Quotes for Related Technology Equipment
- h. 4.5 Approve and authorize the School Board President to sign Interlocal Agreement between the Juvenile Probation Department and the El Paso Independent School District for the Juvenile Alternative Education Program (JJAEP)
- i. 5.1 Review of Policy CW (Local) – New Facilities as recommended by Policy Committee – first reading

Regular
Board
Meeting
Minutes
11/9/04
page 5

MINUTES
CANUTILLO INDEPENDENT SCHOOL DISTRICT
PUBLIC MEETING OF THE BOARD OF TRUSTEES

MEMBERS

MR. CORONADO	MR. FRIETZE	MR. HECKER	MR. LERMA	MR. REYES	MRS. SANCHEZ	MR. VILLARREAL
--------------	-------------	------------	-----------	-----------	--------------	----------------

Motion
Second
Ayes
Nays
Abstain

Item:

Reference:

Motion to approve the consent agenda items 2.2, 3.1, 3.5, 3.6, 4.3, 4.4, 4.5, and 5.1, passed.*

**Mr. Hecker had stepped out of the room during the casting of the vote.*

1.8 Reports

Agenda item 1.8.1 was taken out of order with the consent of the Board after item 1.5.2

1.8.1 Superintendent's Report

- Recognition of Hector Giron, Canutillo Elementary School Principal, appointed to Educational Technology Advisory Committee

Pgs. 34-35

Mr. Hart presented a special recognition plaque to Hector Giron, CES Principal, for his recent appointment to the Education Technology Advisory Committee (ETAC) by the Texas Education Agency.

1.8.2 Financial, Attendance and Warrant List for October 1st-22nd 2004 in the amount of **\$3,042,112.81**

Pgs. 36-38

Regular
Board Mtg.
Minutes
11/9/04
page 6

**MINUTES
CANUTILLO INDEPENDENT SCHOOL DISTRICT
PUBLIC MEETING OF THE BOARD OF TRUSTEES**

MEMBERS

MR. CORONADO	MR. FRIETZE	MR. HECKER	MR. LERMA	MR. REYES	MRS. SANCHEZ	MR. VILLARREAL
--------------	-------------	------------	-----------	-----------	--------------	----------------

Motion
Second
Ayes
Nays
Abstain

Item:

Reference:

Motion that the Board approve the financial, attendance and warrant list for October 1-22, 2004 in the amount of \$3,042,112.81, passed.*

**Mr. Hecker had stepped out of the room during the casting of the vote. The following Board Members abstained from approval of the warrant list, specifically as follows:*

*Sergio Coronado Page 1
Carl Fietze Page 1*

1.8.3 Other Reports

- Progress Report on Construction of New High School – Dimensions Architects International & Banes General Contractors, Inc.

The Board was presented with a progress report on the construction of the new high school. Fred Siebert, Banes General Contractors Project Manager, said that the new high school was 55% complete and on schedule.

- Year End Investment Report 2004 (To Include Last Quarter) – Tony Reza

Mr. Reza presented the year-end investment report for 2004. He said that the accrued interest for the year is \$375,056.

Pgs. 39-60

Regular Board Meeting Minutes 11/9/04 page 7

**MINUTES
CANUTILLO INDEPENDENT SCHOOL DISTRICT
PUBLIC MEETING OF THE BOARD OF TRUSTEES**

MEMBERS

MR. CORONADO	MR. FRIETZE	MR. HECKER	MR. LERMA	MR. REYES	MRS. SANCHEZ	MR. VILLARREAL
--------------	-------------	------------	-----------	-----------	--------------	----------------

Motion
Second
Ayes
Nays
Abstain

Item:	Reference:
<p>2.0 Instruction and Student Affairs</p> <p>2.1 Approval of Goals & Objectives for District and Campus Improvement Plans</p> <p>Motion to approve the Goals & Objectives for District and Campus Improvement Plans, passed.</p>	Pg. 61
<p>2.2 Recommendation for School Health Advisory Council (SHAC) Membership</p> <p>Action on this item was taken and approved by the Board of Trustees under consent agenda.</p>	Pgs. 62-63
<p>3.0 Personnel</p> <p>3.1 Creation of Positions – IT Technical Support Specialist</p> <p>Action on this item was taken and approved by the Board of Trustees under consent agenda.</p>	Pg. 64

Regular Board Meeting Minutes 11/9/04 page 8

**MINUTES
CANUTILLO INDEPENDENT SCHOOL DISTRICT
PUBLIC MEETING OF THE BOARD OF TRUSTEES**

MEMBERS

MR. CORONADO
MR. FRIETZE
MR. HECKER
MR. IERMA
MR. REYES
MRS. SANCHEZ
MR. VILLARREAL

Item:	Reference:
<p>3.2 through 3.4</p> <p>NONE</p>	
<p>3.5 Leave of Absence Requests</p> <p>Action on this item was taken and approved by the Board of Trustees under consent agenda.</p>	Pg. 65
<p>3.6 Supplemental Assignments – Addition to Stipend List (Occupational Therapist)</p> <p>Action on this item was taken and approved by the Board of Trustees under consent agenda.</p>	Pg. 66
<p>3.7 Other Personnel Actions</p>	

**MINUTES
CANUTILLO INDEPENDENT SCHOOL DISTRICT
PUBLIC MEETING OF THE BOARD OF TRUSTEES**

MEMBERS

MR. CORONADO
MR. FRIETZE
MR. HECKER
MR. LERMA
MR. REYES
MRS. SANCHEZ
MR. VILLARREAL

Item:												
<p>3.7.1 Discussion of issues and concerns regarding Canutillo High School and possible recommendation to the Board (item requested by Mr. Frieze)</p> <p>The Board of Trustees adjourned into closed session from 7:36 p.m. through 8:21 p.m. under the authority of Texas Revised Civil Statutes Annotated, Texas Government Code Sections 551.074 and 551.082. The Board of Trustees took no formal action on this item.</p> <p>3.8 Administrative Personnel Actions (no Board action required – information item only)</p> <p>3.8.1 Superintendent approved employment of personnel (no Board action required)</p> <p>Superintendent approved employment of personnel:</p> <table style="margin-left: 40px;"> <tr> <td>Rosalia Becerrill</td> <td>FS Substitute, Effective 10/27/04</td> </tr> <tr> <td>Ann Carrera</td> <td>FS Substitute, Effective 10/14/04</td> </tr> <tr> <td>Mirna Figueroa</td> <td>FS Substitute, Effective 10/18/04</td> </tr> <tr> <td>James Gonzales</td> <td>TLC Lead Teacher, Effective 10/19/04</td> </tr> <tr> <td>Juana Gutierrez</td> <td>Auxiliary Personnel Specialist, Effective 10/18/04</td> </tr> <tr> <td>Esther Rocha</td> <td>Special Needs Assistant Caregiver, CES, Effective 10/25/04</td> </tr> </table>	Rosalia Becerrill	FS Substitute, Effective 10/27/04	Ann Carrera	FS Substitute, Effective 10/14/04	Mirna Figueroa	FS Substitute, Effective 10/18/04	James Gonzales	TLC Lead Teacher, Effective 10/19/04	Juana Gutierrez	Auxiliary Personnel Specialist, Effective 10/18/04	Esther Rocha	Special Needs Assistant Caregiver, CES, Effective 10/25/04
Rosalia Becerrill	FS Substitute, Effective 10/27/04											
Ann Carrera	FS Substitute, Effective 10/14/04											
Mirna Figueroa	FS Substitute, Effective 10/18/04											
James Gonzales	TLC Lead Teacher, Effective 10/19/04											
Juana Gutierrez	Auxiliary Personnel Specialist, Effective 10/18/04											
Esther Rocha	Special Needs Assistant Caregiver, CES, Effective 10/25/04											

Reference:
<p>Pgs. 67-70</p> <p>Regular Board Meeting Minutes 11/9/04 page 10</p>

MINUTES
CANUTILLO INDEPENDENT SCHOOL DISTRICT
PUBLIC MEETING OF THE BOARD OF TRUSTEES

MEMBERS

MR. CORONADO	MR. PRIETZE	MR. HECKER	MR. LERMA	MR. REYES	MRS. SANCHEZ	MR. VILLARREAL
--------------	-------------	------------	-----------	-----------	--------------	----------------

Item:

Reference:

3.8.2 Superintendent approved position changes for personnel (no Board action required)

Pgs. 67-68

Mr. Hart approved position changes for personnel:

- | | |
|-------------------|--|
| Ramon Gallegos | Custodian to Interim Asst.
Lead Custodian,
Effective 7/23/04 |
| Daniel Gomez | Technology Assistant, BCE, to
6 th Grade Bilingual Teacher, BCE
Effective 11/1/04 |
| Leticia Martinez | SEMS/SERS Clerk to Special Ed.
Dept. Secretary,
Effective 10/14/04 |
| Rosa Santillano | FS Assistant Manager to
Interim Manager,
Effective 10/18/04 |
| Rosa Santillano | FS Interim Manager to
FS Manager,
Effective 10/25/04 |
| Guadalupe Villela | FS Helper to FS Baker,
Effective 10/7/04 |

3.8.3 Superintendent acceptance of resignations from personnel (no Board action required)

Pg. 68

Mr. Hart accepted resignations from personnel:

- | | |
|----------------|--------------------------------------|
| Rita Dominquez | FS Helper, JDE,
Effective 10/1/04 |
|----------------|--------------------------------------|

Regular
Board
Meeting
Minutes
11/9/04
page 11

MINUTES
CANUTILLO INDEPENDENT SCHOOL DISTRICT
PUBLIC MEETING OF THE BOARD OF TRUSTEES

MEMBERS

MR. CORONADO	MR. FRIETZE	MR. HECKER	MR. LERMA	MR. REYES	MRS. SANCHEZ	MR. VILLARREAL
--------------	-------------	------------	-----------	-----------	--------------	----------------

Item:

Reference:

Bertha Gauna Campus Technology Assistant,
Effective 10/15/04

Omar Hernandez 6th Grade Bil. Teacher, BCE,
Effective 10/15/04

4.0 Business and Finance

4.1 Budget Amendments

Mr. Reza presented additional information pertaining to the budget amendment for food service department. Mr. Baskind, legal counsel for the district, had requested more detailed information than what was listed on page 78. Mr. Reza requested that page 80 be replaced with additional information, which was given to the Board. Mr. Reza also requested that a change be made on page 77 on construction fees from \$280,642 to **\$263,116**. This new figure is based on what expenditures are allowable under the regulations for the Child Nutrition Program. (Please see attachment to minutes)

Motion to approve the budget amendments as noted on pages 71 through 98 with the corrections noted on the budget amendment on page 77 for "*construction fees*" from \$280,642 to \$263,116, changing "*equity total transfer out*" amount to \$363,116, passed.

4.2 Donations to Canutillo Independent School District

Pgs. 71-98

Pgs. 99-103

Regular
Board Mtg.
Minutes
11/9/04
page 12

Motion
Second
Ayes
Nays
Abstain

✓ ✓ ✓ ✓ ✓ ✓

MINUTES
CANUTILLO INDEPENDENT SCHOOL DISTRICT
PUBLIC MEETING OF THE BOARD OF TRUSTEES

MEMBERS

	MR. CORONADO	MR. FRIETZE	MR. HECKER	MR. LERMA	MR. REYES	MRS. SANCHEZ	MR. VILLARREAL	Item:	Reference:
Motion					✓			Motion to accept the donations to Canutillo ISD as listed on pages 99-103 (from Office Max for school supplies for \$56.94 and Westway Foods for \$75.00), passed.	
Second			✓						
Ayes	✓	✓	✓	✓	✓	✓			
Nays									
Abstain									
								4.3 Purchase Copy Paper	Pgs. 104-107
								Action on this item was taken and approved by the Board of Trustees under consent agenda.	
								4.4 CISV Quotes for Related Technology Equipment	Pgs. 108-116
								Action on this item was taken and approved by the Board of Trustees under consent agenda.	
								4.5 Approve and authorize the School Board President to sign Interlocal Agreement between the Juvenile Probation Department and the El Paso Independent School District for the Juvenile Alternative Education Program (JJAEP)	Pgs. 117-145
								Action on this item was taken and approved by the Board of Trustees under consent agenda.	
									Regular Board Mtg. Minutes 11/9/04 page 13

**MINUTES
CANUTILLO INDEPENDENT SCHOOL DISTRICT
PUBLIC MEETING OF THE BOARD OF TRUSTEES**

MEMBERS

MR. CORONADO	MR. FRUETZE	MR. HECKER	MR. LERMA	MR. REYES	MRS. SANCHEZ	MR. VILLARREAL
--------------	-------------	------------	-----------	-----------	--------------	----------------

Item:

Reference:

5.0 Administration

5.1 Review of Policy CW (Local) – New Facilities as recommended by Policy Committee – first reading

Pgs. 146-148

Action on this item was taken and approved by the Board of Trustees under consent agenda.

5.2 Review of TASB Localized Policy Manual Update 73 as recommended by Policy Committee (including Policies GKD (Local) and GKDA (Local)) – first reading

Pgs. 149-161

Motion that the Board accept for first reading TASB Localized Policy Manual Update 73 as recommended by Policy Committee including Policies GKD (Local) and GKDA (Local), passed.

Motion
Second
Ayes
Nays
Abstain

	✓					
✓	✓	✓	✓	✓	✓	✓

6.0 Adjournment

Motion for adjournment of the public meeting 8:36 p.m. passed by unanimous consent.

Motion
Second

✓	✓
---	---

Regular
Board
Meeting
Minutes
11/9/04
page 14

Canutillo ISD
 Fiscal Year Ending 8/31/2005
 Canutillo High School
 Kitchen Equipment Up-Grade

Attachment to Regular Board Meeting
 November 9, 2004 Minutes
 Page 15

Code	Description	Revised Quote	Unallowable Expenditures	Allowable Expenditures
2.001	Earthwork (By Banes)	\$1,043.00	\$1,043.00	
3.001	Concrete	\$2,138.00	\$2,138.00	
5.105	Structural Steel	\$4,350.00	\$4,350.00	
5.106	Structural Steel Erection	\$1,290.00	\$1,290.00	
6.100	Carpentry (By Banes)	\$1,975.00	\$1,975.00	
7.100	Built Up Roof and Additional Penetrations	\$2,270.00		\$2,270.00
9.330	DW and paint	\$1,000.00		\$1,000.00
10.001	Specialties	\$550.00		\$550.00
15.015	Mechanical	\$39,300.00		\$39,300.00
	Mechanical Design	\$3,500.00		\$3,500.00
15.001	Plumbing	\$99,812.00		\$99,812.00
15.015	Fire Protection	\$8,525.00		\$8,525.00
16.001	Electrical	\$17,250.00		\$17,250.00
13.003	Special Systems	\$4,630.00		\$4,630.00
Subtotal for Allocation Purposes		\$187,633.00	\$10,796.00	\$ 176,837.00
Allocation Ratio			6%	94%
1.000	General Conditions	\$10,875.00	\$652.50	\$10,222.50
Total base construction costs		\$198,508.00	\$11,448.50	\$187,059.50
Overhead 5%		\$9,925.40	\$595.52	\$9,329.88
Construction Fees 3.4%		\$6,749.27	\$404.96	\$6,344.32
Total Construction Budget		\$215,183	\$12,449	\$202,734
Architect fees and services		\$64,728	\$3,884	\$60,844
GNP of F/S Equipment-\$35,105				
Consulting Services of Work-29,623				
BUDGET AMENDMENT		\$279,911	\$16,795	\$263,116

BOLD AMOUNTS ALLOCATED BASED ON RATIO

- > To be charged later to the General Fund - Fund Balance
- >> To be charged to the Food Service - Fund Balance

Adele Balesh

From: Karla Rodgers [krodgers@spider.esc19.net]
Sent: Tuesday, November 09, 2004 9:01 AM
To: abalesh@canutillo-isd.org
Subject: Equipment Purchases



krodgers.vcf (354
B)

Adele,

Modifications to the cafeteria, such as additional plumbing and changes for utility usage, are allowable expenditures provided that they are needed to support the new high school cafeteria equipment that was purchased. Refer to section 14.2 and 14.3 in the Child Nutrition Administrator's Reference Manual.

Karla Rodgers
Child Nutrition Program Specialist
Education Service Center, Region 19
6611 Boeing Drive
El Paso, TX 79925
(915) 780-5326
(915) 780-6574 FAX

Attachment to Regular Board Meeting Minutes
November 9, 2004
page 16

*Done 11/9/04
10 21*

MINUTES
CANUTILLO INDEPENDENT SCHOOL DISTRICT
PUBLIC MEETING OF THE BOARD OF TRUSTEES

MEMBERS

MR. CORONADO	MR. FRIETZE	MR. HECKER	MR. LERMA	MR. REYES	MRS. SANCHEZ	MR. VILLARREAL
--------------	-------------	------------	-----------	-----------	--------------	----------------

Type of Meeting: Special Board Meeting

Location Canutillo ISD Administration Office
 7965 Artcraft - El Paso, Texas

Date: (Thursday) November 11, 2004 **Time:** 6:08 p.m.

Item:

Reference:

Present

1.0 General Functions

1.1 Call to Order

1.2 Roll Call (Mr. Reyes arrived at 6:15 p.m. and Mr. Villarreal was absent.)

Mr. Fietze, Board Vice-President, presided over the meeting.

Mr. Fietze wanted the record to reflect that Mr. Villarreal was out of town and had experienced some problems with his vehicle on his way home.

1.3 through 1.5

NONE

2.0 Instruction and Student Affairs

NONE

3.0 Personnel

NONE

4.0 Business and Finance

4.1 Discussion with contractor and architect for the new high school - The following items will be discussed:

- Report from Construction Administrator regarding Geothermal Technology
- Relationship between price of oil and artificial turf
- Update on negotiations with Enlink
- Presentation by US Track & Field and discussion on financing plan

MINUTES
CANUTILLO INDEPENDENT SCHOOL DISTRICT
PUBLIC MEETING OF THE BOARD OF TRUSTEES

MEMBERS

MR. CORONADO	MR. FRITZE	MR. HECKER	MR. LERMA	MR. REYES	MRS. SANCHEZ	MR. VILLARREAL
--------------	------------	------------	-----------	-----------	--------------	----------------

Item:

Reference:

Due to the arrival of Mr. Frank Johnson from US Track and Turf, the items for discussion were taken out of order.

- Presentation by US Track & Field and discussion on financing plan

(Agenda item should have read: Presentation by US Track & Turf and discussion on financing plan.)

Due to the arrival of Mr. Frank Johnson from US Track and Turf, the items for discussion were taken out of order. Mr. Siebert explained that US Track & Turf were the low bidder on this project. Mr. Johnson made a short presentation to the Board regarding fields his company had done. Mr. Johnson stated that selling points for the installation of turf are as follows: maintenance-free, safety and usability. Mr. Robert Velasquez, Business Manager for Crystal City ISD was also present. Mr. Velasquez served as a reference for US Track and Turf. Mr. Velasquez explained the benefits of having a field with artificial turf and the financing plan done by his school district to pay for it. The Board discussed various financing options for this project. Mr. Baskind suggested that the Board determine whether or not they wanted artificial turf and then direct administration and legal counsel to negotiate with the low bidder.

Motion to instruct the administration to go forward, investigate the options into the installation of artificial turf (which will include the football field and track); commence negotiations with US Track & Turf; discuss possible finance options and report back to the Board, passed.

Motion ✓
 Second ✓
 Ayes ✓
 Nays ✓
 Abstain ✓

Special Board Meeting Minutes 11/11/04 page 2

**MINUTES
CANUTILLO INDEPENDENT SCHOOL DISTRICT
PUBLIC MEETING OF THE BOARD OF TRUSTEES**

MEMBERS

MR. CORONADO	MR. FRIETZE	MR. HECKER	MR. LERMA	MR. REYES	MRS. SANCHEZ	MR. VILLARREAL
--------------	-------------	------------	-----------	-----------	--------------	----------------

Item:

Reference:

- Relationship between price of oil and artificial turf

Mr. Farran stated that there was a relationship between the price of oil and artificial turf. He further provided an example with the present price of a barrel of crude oil. The Board on this item took no official action.

- Report from Construction Administrator regarding Geothermal Technology

Mr. Farran reported on a meeting held with the CMR regarding the on-going negotiations for the completion of ductwork for the geothermal energy at the new high school. The Board on this item took no official action.

- Update on negotiations with Enlink

The Board of Trustees adjourned into closed session from 7:38 p.m. through 8:15 p.m. under the authority of Texas Revised Civil Statutes Annotated, Texas Government Code Section 551.077. The Board on this item took no official action.

4.2 Presentation from Banes General Contractors, Inc. on received bids for "Education Boulevard"

Motion that the Board instruct the CMR to begin the negotiations for earthwork, curb and gutter paving and storm drain system for Education Boulevard with Allied but not finalize a contract until the school district has entered into a Interlocal Agreement with El Paso Community College, passed.

Motion
Second
Ayes
Nays
Abstain

✓						
✓	✓		✓	✓	✓	
		✓				

Special Board Meeting Minutes 11/11/04 page 3

**MINUTES
CANUTILLO INDEPENDENT SCHOOL DISTRICT
PUBLIC MEETING OF THE BOARD OF TRUSTEES**

MEMBERS

MR. CORONADO	MR. FRIETZE	MR. HECKER	MR. LERMA	MR. REYES	MRS. SANCHEZ	MR. VILLARREAL	Item:	Reference:
							<p>5.0 Administration</p> <p>NONE</p> <p>6.0 Adjournment</p> <p>Motion for adjournment of the public meeting at 8:36 p.m., passed by acclamation.</p>	
		✓					<p>Motion</p> <p>Second</p>	
				✓				<p>Special Board Meeting Minutes 11/11/04 page 4</p>

DECEMBER-----

Action Items

Review/Approve Financial Audit
Budget for Board Goals & Priorities for Coming School Year

Other Items

“Pre-evaluation” of Superintendent (Report on District Status)
Review Campus Report Cards

Important Dates

Pearl Harbor Day (Dec. 7)
Human Rights Day (Dec. 10)
Bill of Rights Day (Dec. 15)
Christmas (Dec. 25)

Events

Board Christmas Dinner
Retreat with TASB Consultant



Canutillo Independent School District

7965 Artcraft Rd.
El Paso, TX 79932

Mailing Address: P.O. Box 100
Canutillo, Texas 79835

John P. Kessinger, Ed. D.
Assistant Superintendent

Facilities & Finance Committee Meeting Minutes
November 29, 2004

(915) 877-7475
FAX (915) 877-7477
jkessinger@canutillo.k12.tx.us

Location: Administration Building
Time: 6:10 p.m. – 9:07 p.m.

Board Committee Members Present: Mr. Coronado, Mr. Frietze and Mr. Hecker.

Others Present: Mr. Charles Hart, Dr. Kessinger, Dr. Padilla, Rene O'Donnell, Tony Reza, Larry Baskind, Yvonne Sanchez, Frank Lerma, Sergio Martinez, Yvonne Duby, Yolanda Lucero.

The meeting was called to order at 6:10 p.m.

4.0 Business and Finance

Five Year Plan Update: Mr. Coronado informed the committee members that Mr. Villarreal had another commitment and would be out of town and would not be able to attend. Mr. Reyes also called in and said he had a family commitment and would not be able to attend. Dr. Kessinger greeted the committee members and explained that he is part one of part four on the Five Year Plan Update. Dr. Kessinger told them they had a manila folder in front of them with his power point presentation so they can follow along. In addition, there is copy of the Rancho Las Lomas concept plan, which is the Hunt development. The third item in their folder is a colored plat that will be discussed later and also included is a copy of an economic development plan for their information. Dr. Kessinger thanked Dr. Padilla, Mrs. O'Donnell and Tony Reza for participating in this and getting all the updates and sharing all this information on the Five Year Plan Update. Dr. Kessinger explained to the committee how the projected numbers were calculated. Based on these numbers, Mrs. O'Donnell built her proposal on these numbers for the required numbers of staff. From there, Mr. Reza calculated the projected costs and then Dr. Padilla will wrap up with the curriculum implications. Dr. Kessinger went over the various scenarios and projections for the different possibilities we could be facing within the next five years. Dr. Kessinger also went over the developments that are currently going up, what their status is and whether they are on schedule or behind schedule and what that could mean for student population. Dr. Kessinger also asked for a minimum of 2 more school buses that will be needed to bus the children coming from these new subdivisions. Eventually there will be attendance zone changes and acquisition for land for new school sites. The committee members asked Dr. Kessinger questions and discussed various possibilities for the future. Mrs. O'Donnell gave her power point presentation on her projections broken out by school and using a 20 to 1 ratio for personnel needs to match the Dr. Kessinger's growth projections for the next five years. Mrs. O'Donnell went over each individual campus and their needs for personnel with the committee members and explained all her configurations as to how she arrived at the numbers for added personnel. Mrs. O'Donnell answered questions from the committee members and told them that the coming years are going to be a challenge which means they will all be working together to balance out the numbers. Mr. Reza gave his financial projections with respect to the Five Year Plan. On the finance side you have to look at you average daily attendance because that's how the District received its funding. This year Mr. Reza projected a growth of 4%. Mr. Reza went over his power point presentation to the committee members and explained every detail of projected financial needs and what will be needed to budget for future years. Mr. Reza explained that our state revenues are declining because the state values are at 12% and our student growth is only at 5%. Until our ADA matches our growth and values we will lose money on the state side. Mr. Reza went over the projected financial needs by campus, departments and year by year and what the need and projected budget will be. Mr. Reza explained to the committee members that for the next three years the budget will have to dip into the fund balance but after that we should be doing better. Mr. Hart also told the committee members

that Mr. Reza has given the worst case scenario so that there will be no surprises and for them to keep that in mind. The committee members asked Mr. Reza questions and discussed several issues. Dr. Padilla gave her power point presentation and she felt she had good news for her part of the report. Because they won't see dollars signs and because they have worked really hard the past couple of years and continued to believe they have the resources to have the infra- structure to support this kind of growth without impacting the local budget. We are very lucky in that we are getting some pretty steady increases in some of the federal funds and we are able to offset the cost of our professional development with those federal funds. We would like to see more and we still think no child left behind is not fully funded. But for the most part we find ourselves feeling we can handle this growth with the infrastructure, especially the technology infrastructure that has been provided for us. Dr. Padilla did want to remind the committee as we go through these years where we are expecting pretty heavy duty growth in students we do have two accountability systems that we have to answer to and the first one is the state accountability system. In this system, we have to be academically acceptable across the four core curriculum areas. These standards will last until 2006 and we are not sure how the state is going to raise them for the 2006-2007 school year. The committee that worked in the accountability system for the state has left that question unanswered. The state is going to wait and see how many schools and districts across the state are able to meet these standards before they recalibrate for the acceptable category. However, they were less cautious about determining what we needed to be to be either recognized or exemplary. Dr. Padilla told the committee that we will be able to enjoy this same standard for recognized campus and district in each of the core curriculum areas of 70% through the 2005-2006 school year. The state is then going to ratchet up in 2006-2007 to 75% and then go to 80% in 2007-2008-2009. Dr. Padilla went through her power point presentation on her projected numbers for the five year plan. Dr. Padilla answered the questions of the committee members on her projected numbers and research to raise these levels. Dr. Padilla presented curriculum Management Audit 1-9. Dr. Padilla went over the eighteen barriers to overcome and the Superintendent's Goals. Dr. Padilla explained all the resources the district is using to overcome any problems that might get in the way of giving us a better commitment to help our student. Dr. Padilla is sure she can have the IEP's for all students in four years. Dr. Padilla wanted the committee members to know what some of the priority areas are and some of the constraints that they are a little worried about in responding to the two accountability systems in the same years that we expect to be growing.

After the presentations, Dr. Kessinger requested that the committee members go into executive session to discuss the acquisition of land with the school attorney. The Board of Trustees adjourned into closed session from 8:42 p.m. through 9:05 p.m. under the authority of Texas Open Meetings Act, Texas Government Code Section 551.07 and 551.073. The committee members came back to the regular session of the Facilities and Finance Committee meeting. There was no recommendation from the committee members. They will put the acquisition for land on the agenda for the regular board meeting

**Meeting adjourned by consensus at 9:07 p.m.
RMQ**



Canutillo Independent School District

7965 Artcraft Rd.
El Paso, TX 79932

Mailing Address: P.O. Box 100
Canutillo, Texas 79835

Tony Reza
Comptroller

(915) 877-7430
FAX (915) 877-7415
treza@canutillo.k12.tx.us

December 3, 2004

TO: Board of Trustees

THROUGH: Tony Reza *[Signature]*
Comptroller

FROM: Kathy Ellis *[Signature]*

SUBJECT: Approval of Warrant List for October 23-November 30, 2004

Enclosed in your packet is the warrant list for October 23-November 30, 2004. I recommend its approval in the amount of: \$ **2,515,840.04**.

The following Board members abstain from voting on individual payments as follows:

Sergio Coronado	Am. Exp./lodging-TASA/TASB	\$ 441.45	Page 4
Carl Fietze	Am. Exp./lodging-TASA/TASB	\$ 444.45	Page 4
Charley Hecker	Am. Exp./lodging-TASA/TASB	\$ 545.00	Page 4
	Banes General Contractors	\$ 1,739,508.36	Page 9
Frank Lerma	Am. Exp./lodging-TASA/TASB	\$ 545.00	Page 4
Yvonne Sanchez	Am. Exp./lodging-TASA/TASB	\$ 545.00	Page 4
Jose Villarreal	Am. Exp./lodging-TASA/TASB	\$ 545.00	Page 4
	Sprint/cell service fee	\$ 48.74	Page 116

CANUTILLO INDEPENDENT SCHOOL DISTRICT

Monthly ADA and Last Day Enrollment
As of November 30, 2004

<u>Campus</u>	<u>November ADA</u>	<u>Enrollment 11/30/04</u>
Canutillo Elementary School	682.448	737
Deanna Davenport Elementary School	592.289	647
Jose H. Damian Elementary School	661.764	724
Bill Childress Elementary School	720.974	780
Canutillo Middle School	749.158	781
Canutillo High School	1174.290	1240
	<hr/>	<hr/>
DISTRICT TOTALS	4580.923	4909
Ineligible students (Children of employees-out of state and ineligible PK students-not LEP or economically disadvantaged. Tuition is not collected.)		62
		<hr/>
GRAND TOTAL ENROLLMENT		4971

CANUTILLO INDEPENDENT SCHOOL DISTRICT

Year-to-Date Average Daily Membership and ADA
August 16, 2004 through November 30, 2004

<u>Campus</u>	<u>ADM</u>	<u>ADA</u>	<u>ATT %</u>
Canutillo Elementary School	710.896	689.974	97.1%
Deanna Davenport Elementary School	604.263	587.138	97.2%
Jose H. Damian Elementary School	688.258	668.923	97.2%
Bill Childress Elementary School	735.868	719.022	97.7%
Canutillo Middle School	780.444	754.097	96.6%
Canutillo High School	1244.326	1189.133	95.6%
	_____	_____	
*DISTRICT TOTALS	4764.055	4608.287	96.7%

*Does not include ineligible students

**CANUTILLO INDEPENDENT SCHOOL DISTRICT
OFFICE OF THE SUPERINTENDENT
POST OFFICE BOX 100
CANUTILLO, TEXAS**

Date: December 14, 2004

Subject: Leave of Absence Requests

Presented by: Renée O'Donnell

Consent Agenda: ✓

ACTION

1. **BACKGROUND INFORMATION**

Kathy Ellis	Assistant Business Manager
Julia Melendez	Teacher
Viviana Serrano	Teacher

Rationale: ● Ms. Ellis is requesting Family Medical Leave beginning November 15, 2004, and will return upon doctor's release. ● Ms. Melendez is requesting Family Medical Leave beginning November 2, 2004, and will return upon doctor's release. ● Ms. Serrano is requesting Family Medical Leave beginning November 22, 2004, and will return upon doctor's release.

2. **SUPERINTENDENT RECOMMENDATION**

It is recommended that the Board approve these requests.

3. **BOARD ACTION REQUESTED**

Motion to approve leave for Kathy Ellis, Julia Melendez, and Viviana Serrano as recommended by the Superintendent.

MOTION _____ **SECOND** _____

FOR _____ **AGAINST** _____

BOARD PRESIDENT: This Board will adjourn into closed session pursuant to the following section of the Texas Open Meetings Act, Texas Government Code Section 551.074 and 551.082, for evaluation and employment of a public officer or employee.

**CANUTILLO INDEPENDENT SCHOOL DISTRICT
OFFICE OF THE SUPERINTENDENT
POST OFFICE BOX 100
CANUTILLO, TEXAS**

Date: December 14, 2004

Subject: Administrative Personnel Actions for Board of Trustee Information Only

Presented by: Renée O'Donnell

Consent Agenda: _____

ACTION

1. BACKGROUND INFORMATION

Superintendent approved employment of personnel:

Bertha Atayde	Food Service Sub, Effective 11/01/04
Martha Hernandez	Food Service Sub, Effective 11/1/04
Audrie Morgan	Special Ed. Teacher, CHS, Effective 11/29/04
Niceforo Robles	Sub Driver, Effective 11/17/04

Superintendent approved position changes for personnel:

Monica Cazares	Counselor Clerk, CHS, to Sp. Ed. SEMS/SERS Clerk, Effective 11/18/04
Ron Gatlin	Warehouse Supervisor to Warehouse Supervisor/ Energy Manager, Effective 10/1/04
Sandra Guerrero	Receptionist, BCE, 202 days to 226 days, Effective 11/19/04

Superintendent approved resignations:

Jaime Armendariz	Bus Driver, Effective 11/17/04
Hilda Carrera	Custodian, DDE, Effective 11/15/04
Teresa Fresquez	Attendance Clerk, BCE, Effective 11/19/04
Javier Villalva	Maintenance Worker, Effective 11/11/04

Termination of Support Personnel

See under separate cover

BOARD ACTION REQUESTED

No action required.

EMPLOYMENT PRACTICES

PROFESSIONAL PERSONNEL RECOMMENDATION FORM

Name: Audrie Morgan

Replacement Position
 New Position

Recommended Assignment: Special Ed. Teacher, CHS

Department/Funding Source: 199.11.6119.00.001.5.30 (33.33%)

199.11.6119.00.001.5.23 (66.67%)

Effective Date
of Assignment: 11/29/04 Salary: \$21,270.59, 0 yrs. exp.

Terms of Employment: 187 day probationary contract
prorated to 113 days

Certification: Probationary Certificate
Special Ed. (ASTEP)

Experience: First year teacher

Education: MS - Calvary Bible College &
Theological Seminary
BS - Ferris State University

Interviewed by: Derrick Brown

Number of other candidates interviewed for this position: 2

List other interviewees: Nancy Hines and Gale Sanchez

Qualifications Required: Texas teacher certification as per SBEC rules and regulations.

Comments: Ms. Morgan is a replacement for Amy Egger who resigned.

Criminal Record Check: None

References Checked:

Jackie Fendley
Name

Rod Cariker
Name

Nominated by: Derrick Brown Principal 11/16/04
Name Title Date

Pam Farris 11-19-04
Assistant Superintendent Concurrence Date

Gene O'Brien 11-18-04
Executive Director, Human Resources Date

[Signature] 11/19/04
Superintendent's Approval Date

CANUTILLO INDEPENDENT SCHOOL DISTRICT
OFFICE OF THE SUPERINTENDENT
POST OFFICE BOX 100
CANUTILLO, TEXAS

Agenda Item: _____

Date: December 14, 2004

Subject: Kitchen Construction at New CHS

Presented By: Tony Reza

Consent Agenda: X

ACTION

1. BACKGROUND INFORMATION:

The enclosed budget amendment is to budget funds in the operating budget for the unallowable cost for the kitchen upgrade at the new high school. These costs cannot be charged to the Construction or the Food Service budgets.

2. SUPERINTENDENT RECOMMENDATION:

The Superintendent recommends approval of the requested budget amendment.

3. ACTION REQUESTED:

The Board of Trustees approves the requested budget amendment.

MOTION _____ SECOND _____

AYES _____ NAYS _____

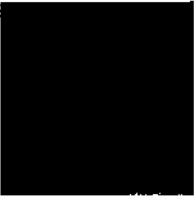

**CANUTILLO INDEPENDENT SCHOOL DISTRICT
OFFICE OF THE SUPERINTENDENT
BOARD AMENDMENT EXECUTIVE SUMMARY SHEET**

FUNDING SOURCE:

The district's unreserved and undesignated fund balance will be the funding source.

IF GRANT, PLEASE PROVIDE THE FOLLOWING: N/A

- GRANT AWARD:
- GRANT PERIOD:
- GRANT OBJECTIVES:
- GRANTING AGENCY:

PURPOSE OF THE AMENDMENT:

This amendment will fund the district's share of construction costs that cannot be charge to federal funds. The new high school cafeteria will be modified to support the new cafeteria equipment that was purchased by the Food Service department. This modification will require some construction that cannot be charged to federal funds, as such, these unallowable expenditures will be charged to these funds.

HOW WILL THIS IMPACT EDUCATION:

This item will provide the cafeteria for the new high school.

WHAT DISTRICT OR CAMPUS GOALS WILL BE MET WITH THIS AMENDMENT:

This will allow all district and campus goals to be achieved.

TO: Charles Hart, Superintendent

TO: Tony Reza, Comptroller

FROM: Kathy Ellis, Assistant Business Manager

SUBJECT: Kitchen Construction New CHS

DATE: December 8, 2004

BUDGET CODE	CURRENT BUDGET	CHANGE	AMENDED BUDGET
			-
199.81.6629.00.001.5.99 Construction		12,449	12,449
199.81.6629.01.001.5.99 Construction Fees		3,884	3,884
199.00.8999.00.000.5.00 Equity Transfer Out		(16,795)	(16,795)

REASON FOR BUDGET AMENDMENT REQUEST: To budget funds for the unallowable costs for the kitchen upgrade at the New CHS. These costs cannot be charged to the Construction budget or the Food Service budget.

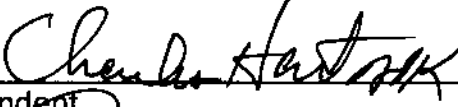

Superintendent

12-08-04
Date

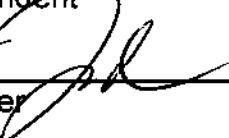

Comptroller

12/8/04
Date

CANUTILLO INDEPENDENT SCHOOL DISTRICT
OFFICE OF THE SUPERINTENDENT
POST OFFICE BOX 100
CANUTILLO, TEXAS

Agenda Item: _____

Date: December 14, 2004

Subject: Special Education – BJE # 1087

Presented By: Tony Reza

Consent Agenda: __X__

ACTION

1. BACKGROUND INFORMATION:

The enclosed budget amendment is to transfer funds from function 21 to function 51 to provide funds to install a kitchen in the DSC classroom at Canutillo Middle School.

2. SUPERINTENDENT RECOMMENDATION:

The Superintendent recommends approval of the requested budget amendment.

3. ACTION REQUESTED:

The Board of Trustees approves the requested budget amendment.

MOTION _____ SECOND _____

AYES _____ NAYS _____

Date: 12/08/04

Reason:

FUNDING SOURCE: STATE FUNDING

PURPOSE OF THE AMENDMENT: CONSTRUCTION COST TO REMOVE WALLS IN THE DSC UNIT TO INSTALL A FUNCTIONAL KITCHEN

HOW WILL THIS IMPACT EDUCATION: THE KITCHEN WILL ENABLE DSC STUDENT TO INCORPORATE COOKING SKILLS THAT ARE INCLUDED IN THEIR INDIVIDUAL EDUCATIONAL PLANS (IEPS)

WHAT DISTRICT OR CAMPUS GOALS WILL BE MET WITH THIS AMENDMENT: STUDENTS WILL ACQUIRE FUNCTIONAL LIVING SKILLS THAT WILL ENABLE THEM TO BE INDEPENDENT.

Mode: **Lookup**

Cancel? N

TO: Charles Hart, Superintendent
 THROUGH: Tony Reza, Comptroller
 FROM: Kathy Ellis, Assistant Business Manager
 SUBJECT: Special Education Department - BJE #1087
 DATE: December 8, 2004

BUDGET CODE	CURRENT BUDGET	CHANGE	AMENDED BUDGET
199.21.6411.00.918.5.23 Employee Travel	2,000.00	(1,000.00)	1,000.00
199.21.6329.00.918.5.23 Reading Materials	500.00	(450.00)	50.00
199.51.6299.00.918.5.23 Misc Contracted Svcs	-	1,450.00	1,450.00

REASON FOR AMENDMENT REQUEST - This budget amendment is to transfer funds from function 21 to function 51 to provide funds to install a kitchen in the DSC classroom at Canutillo Middle School.

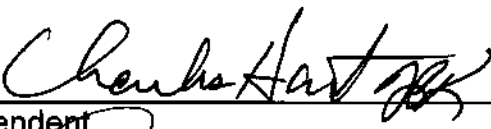

 Superintendent

12-08-04
 Date

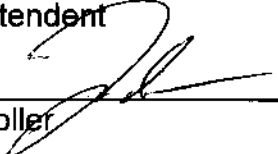

 Comptroller

12/8/04
 Date

Canutillo ISD
 Fiscal Year Ending 8/31/2005
 Canutillo High School
 Kitchen Equipment Up-Grade

Code	Description	Revised Quote	Unallowable Expenditures	Allowable Expenditures
2.001	Earthwork (By Banes)	\$1,043.00	\$1,043.00	
3.001	Concrete	\$2,138.00	\$2,138.00	
5.105	Structural Steel	\$4,350.00	\$4,350.00	
5.106	Structural Steel Erection	\$1,290.00	\$1,290.00	
6.100	Carpentry (By Banes)	\$1,975.00	\$1,975.00	
7.100	Built Up Roof and Additional Penetrations	\$2,270.00		\$2,270.00
9.330	DW and paint	\$1,000.00		\$1,000.00
10.001	Specialties	\$550.00		\$550.00
15.015	Mechanical	\$39,300.00		\$39,300.00
	Mechanical Design	\$3,500.00		\$3,500.00
15.001	Plumbing	\$99,812.00		\$99,812.00
15.015	Fire Protection	\$8,525.00		\$8,525.00
16.001	Electrical	\$17,250.00		\$17,250.00
13.003	Special Systems	\$4,630.00		\$4,630.00
	Subtotal for Allocation Purposes	\$187,633.00	\$10,796.00	\$ 176,837.00
	Allocation Ratio		6%	94%
1.000	General Conditions	\$10,875.00	\$652.50	\$10,222.50
Total base construction costs		\$198,508.00	\$11,448.50	\$187,059.50
Overhead 5%		\$9,925.40	\$595.52	\$9,329.88
Construction Fees 3.4%		\$6,749.27	\$404.96	\$6,344.32
Total Construction Budget		\$215,183	\$12,449	\$202,734
Architect fees and services		\$64,728	\$3,884	\$60,844
GNP of F/S Equipment-\$35,105				
Consulting Services of Work-29,623				
BUDGET AMENDMENT		\$279,911	\$16,795	\$263,116
			>	>>

BOLD AMOUNTS ALLOCATED BASED ON RATIO

- > To be charged later to the General Fund - Fund Balance
- >> To be charged to the Food Service - Fund Balance

CANUTILLO INDEPENDENT SCHOOL DISTRICT
OFFICE OF THE SUPERINTENDENT
POST OFFICE BOX 100
CANUTILLO, TEXAS

Agenda Item: _____

Date: December 14, 2004

Subject: Davenport Elementary School – BJE # 1039

Presented By: Tony Reza

Consent Agenda: X

ACTION

1. BACKGROUND INFORMATION:

The enclosed budget amendment is to reallocate funds from function 13 to function 11 to provide funding to pay teachers for tutoring at risk students after school.

2. SUPERINTENDENT RECOMMENDATION:

The Superintendent recommends approval of the requested budget amendment.

3. ACTION REQUESTED:

The Board of Trustees approves the requested budget amendment.

MOTION _____ SECOND _____

AYES _____ NAYS _____

Date: 11/10/04

Reason:
PURPOSE OF THE AMENDMENT: PAY FOR EXTENDED DAY INSTRUCTION FOR IDENTIFIED
AT RISK STUDENTS

HOW WILL THIS IMPACT EDUCATION: ALLOW AT RISK STUDENTS EQUAL OPPORTUNITY TO
ACHIEVE ACADEMICALLY

WHAT DISTRICT OR CAMPUS GOALS WILL BE MET: ALL STUDENTS WILL REACH HIGH ACA
DEMIC STANDARDS, ATTAINING, PROFICIENCY OR BETTER IN THE FOUNDATION CURRICU
LUM

Mode: **Lookup**

Cancel? N

TO: Charles Hart, Superintendent

THROUGH: Tony Reza, Comptroller

FROM: Kathy Ellis, Assistant Business Manager

SUBJECT: Davenport Elementary School - BJE #1039

DATE: December 8, 2004

BUDGET CODE	CURRENT BUDGET	CHANGE	AMENDED BUDGET
199.13.6118.00.102.5.30 Extra Duty Pay	1,548.00	(1,442.00)	106.00
199.11.6118.00.102.5.30 Extra Duty Pay	-	1,442.00	1,442.00

REASON FOR AMENDMENT REQUEST - This budget amendment is to reallocate funds from function 13 to function 11 to provide funding to pay teachers for tutoring at risk students after school.

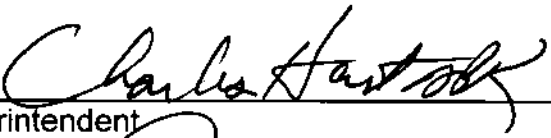

Superintendent

12-08-04
Date



Comptroller

12/8/04
Date

NOV BJE	1039 EXTENDED DAY INSTRUCTION	Total:	.00
CMD	A C C O U N T	TO	FROM

Position To: _____

BEGIN			
0001.000	199.13.6118.00.102.5.30		1,442.00
0002.000	199.11.6118.00.102.5.30	1,442.00	

COMMANDS: L F T E

F2=Process Transfer

POSITION: +n,n.n,-n, Roll-up, Roll-down

CANUTILLO INDEPENDENT SCHOOL DISTRICT
OFFICE OF THE SUPERINTENDENT
POST OFFICE BOX 100
CANUTILLO, TEXAS

Agenda Item: _____

Date: December 14, 2004

Subject: Canutillo Elementary School – BJE # 1067

Presented By: Tony Reza

Consent Agenda: __X__

ACTION

1. BACKGROUND INFORMATION:

The enclosed budget amendment is to reallocate funds from function 23 to function 13 to provide funding to pay for out of town travel for teachers at Canutillo Elementary.

2. SUPERINTENDENT RECOMMENDATION:

The Superintendent recommends approval of the requested budget amendment.

3. ACTION REQUESTED:

The Board of Trustees approves the requested budget amendment.

MOTION _____ SECOND _____

AYES _____ NAYS _____

Date: 11/19/04

Reason:
FUNDING SOURCE: LOCAL INSTRUCTIONAL

PURPOSE OF AMENDMENT: TO PROVIDE FUNDS FOR STAFF TO TRAVEL TO OUT OF TOWN
INSERVICE.

HOW WILL THIS IMPACT EDUCATION: WILL ALLOW FOR STAFF TO IMPLEMENT NEW
IDEAS INTO THE CURRICULUM AS WELL AS HELP THEM DEVELOP THEIR TEACHING
AND CLASSROOM SKILLS.

WHAT GOAL WILL BE MET? DISTRICT GOAL 7. THE DISTRICT WILL PROVIDE
LEADERSHIP, TECHNICAL ASSISTANCE, AND EFFECTIVE AND EFFICIENT
ADMINISTRATION TO ENSURE SCHOOLWIDE AND DISTRICTWIDE IMPROVEMENT.

Mode: **Lookup**

Cancel? N

TO: Charles Hart, Superintendent

THROUGH: Tony Reza, Comptroller

FROM: Kathy Ellis, Assistant Business Manager

SUBJECT: Canutillo Elementary School - BJE # 1067

DATE: December 8, 2004

BUDGET CODE	CURRENT BUDGET	CHANGE	AMENDED BUDGET
199.23.6399.00.101.5.99 General Supplies	9,070.00	(3,000.00)	6,070.00
199.13.6411.00.101.5.11 Employee Travel	-	3,000.00	3,000.00
			-

REASON FOR AMENDMENT REQUEST - This budget amendment is to reallocate funds from function 23 to function 13 to provide funds to pay for out of town travel for teachers at Canutillo Elementary.



Superintendent

12-08-04
Date

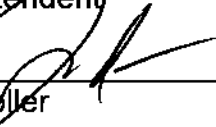

Comptroller

12/8/04
Date

NOV BJE	1067 BUDGET AMMENDMENT	Total:	.00
CMD	A C C O U N T	TO	FROM

Position To: _____

BEGIN			
0001.000	199.23.6399.00.101.5.99		3,000.00
0002.000	199.13.6411.00.101.5.99	3,000.00	

COMMANDS: L F T E

POSITION: +n,n.n,-n, Roll-up, Roll-down

F2=Process Transfer

CANUTILLO INDEPENDENT SCHOOL DISTRICT
OFFICE OF THE SUPERINTENDENT
POST OFFICE BOX 100
CANUTILLO, TEXAS

Agenda Item: _____

Date: December 14, 2004

Subject: Acceptance of Donations to Canutillo ISD

Presented By: Tony Reza

Consent Agenda: _____

ACTION

1. BACKGROUND INFORMATION:

The following businesses and/or individuals have made donations to Canutillo Elementary and Coach Cooper's Project Harmony.

2. SUPERINTENDENT RECOMMENDATION:

The Superintendent recommends acceptance of the donations to Canutillo ISD.

3. ACTION REQUESTED:

The Board of Trustees accepts the donations made to Canutillo ISD.

MOTION _____ SECOND _____

AYES _____ NAYS _____



Canutillo Elementary School

P.O. Box 100, 651 Canutillo Avenue
Canutillo, Texas 79835

(915) 877-7600, FAX (915) 877-7607

HECTOR GIRÓN
Principal

MIKE DILLARD
Assistant Principal

To: Charles Hart, Superintendent
From: Hector Girón 
Date: November 29, 2004
Re: Donations to CES for Project Harmony

The purpose of this memo is to inform you that Canutillo Elementary School has received donations from a large number of people, each donation is for money, food, gift cards, or other items. They are all being received for the purpose of supporting Project Harmony which will provide food baskets to needy families during Thanksgiving and Christmas and for Christmas gifts for children in the CES attendance zone. Accompanying this memo you will find a spreadsheet detailing all of the donors and their donations.

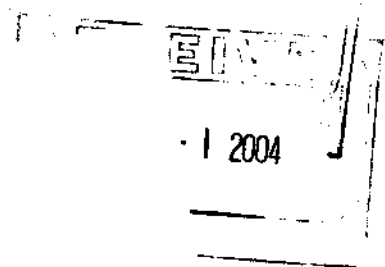

DONOR	ADDRESS	CHECK #	AMOUNT
Carlos and Gretchen Hincapie	6200 Pino Real Dr. El Paso, Texas 79912	7567	15.00
The Reyes Committee Inc.	1011 Montana Avenue, El Paso Tx. 79902	1432	300.00
Lydia and Sergio Camacho	817 Arredondo Dr., El Paso, Tx. 79912-1448	1244	20.00
Logistics Brokers	1000 Hawkins Blvd. El Paso, Tx. 79915	130657	1,500.00
Alicia Watson	9353 Viscount Blvd. Apt. 3008 El Paso, Tx. 79925	143	30.00
Carolyn Wood	P.O. Box 1117 Canutillo, Tx. 79835	2722	20.00
Bertha Leyva	2125 Carlyle Dr. Las Cruces, NM 88005	2810	25.00
Glazed Honey Ham Co.	Colony Cove Shopping Center	F1810 Gift certificate for 1 ham	41.90
Albertson's-Store # 936	3100 North Mesa St.	Gift card	20.00
Wal-Mart-Store #1015	7555 North Mesa	Gift card	50.00
Farmers Dairy Ltd.	7321 North Loop Road El Paso, Tx. 79915	5 gift certificates for 2 (5qt.) containers of icecream/certificate	
Economy Cash and Carry	1000 E. Overland El Paso, Tx 79901	5 bags of rice-100 lbs. each.	98.75
Gorman Distributing	1701 Texas Ave. El Paso, Tx.	Freezer-for holding frozen foods	400.00
Ben and Jessie Cooper	19 South Merrin Street, Plan City, Florida 33566	Table soccer game	350.00

Hoy Fox	11165 Gateway West, El Paso, Tx 79935	031645	250.00
Teachers Federal Credit Union	12020 Rojas Dr. El Paso, Tx. 79936	704071	100.00
Sunland Park Pontiac Buick GMC	955 Crockett Way El Paso, Tx. 79922	054134	600.00
Ben E. Keith Foods	P.O. Box 26656 Alb., NM 87125-7766	Canned goods	512.24
Sun Up/CASA	831 Anthony Rd. Canutillo, Tx. 79835	1040	350.00
Mr. and Mrs. W. R. Wilson	603 Sequoia Spur Georgetown, Tx. 78628	5273	15.00
Edwin and Jamie Coats	225 Three Rivers Dr. El Paso, Tx. 79912	3160	300.00
Martha Hurtado	P.O. Box 9 Canutillo, Tx. 79835	3032	25.00
Sandra and Richard Sapien	178 Cherry Hill Lane Santa Teresa, NM. 88008	760	20.00
Wal-Mart Foundation	702 S. W. 8 th Street Bentonville, Arkansas 72716	1023048	500.00
Donna Powers	P.O. Box 445 Fairacres, NM. 88033	5072	20.00
Laura and Mark Holt	713 Cheltenham El Paso, Tx. 79912	2652	20.00
Margarita Porras-Grant	559 Keifer Lane El Paso, Tx. 79912	2238	25.00

CANUTILLO INDEPENDENT SCHOOL DISTRICT
OFFICE OF THE SUPERINTENDENT
POST OFFICE BOX 100
CANUTILLO, TEXAS

Agenda Item:

Date: December 14, 2004

Subject: Award Armored Car Service RFP # 05-06

Presented By: Tony Reza

Consent Agenda: X

ACTION

1. BACKGROUND INFORMATION:

Proposals for Armored Service was opened on Thursday, December 2, 2004 with two vendors responding. The Finance Department reserves the option to renew this contract for three additional periods of twelve months each. The agreement will be effective January 2005 until December 2005. It is recommended to award the proposal to Azar Security Service which will provides pick-up and delivery service for six (6) campuses, Food Service and the Finance Department for no more than \$15,000.00 per year.

2. SUPERINTENDENT RECOMMENDATION:

The Superintendent recommends approval to award the service of armored car pick-up and delivery to Azar Security Service.

3. BOARD ACTION REQUESTED:

The Board of Trustees approves the Superintendent's recommendation.

MOTION _____ SECOND _____

AYES _____ NAYS _____

December 2, 2004
10:00 am

Canutillo Independent School District
Armored Service
RFP # 05-06

	Azar Security Services	Miracle Delivery Armored Service
Ability to provide pick-up and delivery to every location listed Yes OR No	Yes	Yes
Liability per location:	\$ 100,000.00	\$ 100,000.00
Rate for schedule pick-up:	\$ 7.00	\$ 9.25
Monthly	\$ 154.00	\$ 200.42
Rate for special/unscheduled pick-up between 8 am to 5 pm:	\$ 7.75	\$ 50.00
Rate for special/unscheduled pick-up after 5 pm:	\$ 8.00	\$ 100.00

CANUTILLO INDEPENDENT SCHOOL DISTRICT
OFFICE OF THE SUPERINTENDENT
POST OFFICE BOX 100
CANUTILLO, TEXAS

Agenda Item: Date: December 14, 2004

Subject: Approval to Purchase FFA Truck and Band Trailer

Presented By: Tony Reza Consent Agenda: X

ACTION

1. BACKGROUND INFORMATION:

The FFA Department and the High School Band have reviewed specifications for the purchase of a truck and a cargo trailer. Quotes are being obtained through the Texas Association of School Board Purchasing Program (Buy Board), which meets the Subchapter B, Section 44.031, Item L of the Texas Education Code. This request is to approve the purchase of a Ford F-350 Crew Cab for the FFA Department (\$24,204.00) and a 32' Wells Cargo Trailer for the High School Band program (\$9,075.00) for a total amount of \$33,279.00 from *Philpott Motors LTD*.

2. SUPERINTENDENT RECOMMENDATION:

The Superintendent recommends approval to purchase the truck and trailer for the FFA Department and CHS Band Program from Philpott Motors Company.

3. BOARD ACTION REQUESTED:

The Board of Trustees approves the Superintendent's recommendation.

MOTION _____ SECOND _____

AYES _____ NAYS _____

CANUTILLO INDEPENDENT SCHOOL DISTRICT
OFFICE OF THE SUPERINTENDENT
POST OFFICE BOX 100
CANUTILLO, TEXAS

Agenda Item:

Date: December 14, 2004

Subject: Food Service Child Nutrition Cooperative Purchasing Contracts

Presented By: Tony Reza

Consent Agenda: X

ACTION

1. BACKGROUND INFORMATION:
The Food Service Department participates in several cooperative purchasing programs which will aggregate to over \$10,000. Listed are the cooperative programs, products and awarded companies:

Southwest Texas Food Service Cooperative
Bakery – Flowers Baking Co.
Mexican Food – Isabellas
Dairy – Farmers Dairies

Defense Logistics Agency
Products – Quality Fruit and Vegetables

West Texas Cooperative
Food – Ben E. Keith
Meat – Quinteros

Region XIX Educational Service Center
Equipment and Utensils – JAX, National Restaurant, Pasco, Stepco
Linen – Unifirst
Machine supplies and Extermination – ECO Lab
Paper and Chemical – Grainger, Laundry, Sun Set, SW Mills

2. SUPERINTENDENT RECOMMENDATION:
The Superintendent approves to purchase items, materials and supplies for the Food Service Child Nutrition Program from the listed cooperative purchasing programs.
3. BOARD ACTION REQUESTED:
The Board of Trustees approves the Superintendent's recommendation.

MOTION _____ SECOND _____

AYES _____ NAYS _____

**LIST OF ANNUAL CO-OP BIDS UTILIZED BY
CANUTILLO INDEPENDENT SCHOOL DISTRICT
CHILD NUTRITION PROGRAM . . .**

I. SOUTHWEST TEXAS FOOD SERVICE COOPERATIVE

- 1. BAKERY PRODUCTS – FLOWERS BAKING CO.**
- 2. MEXICAN FOOD PRODUCTS – ISABELLAS**
- 3. DAIRY PRODUCTS – FARMERS DAIRIES**

II. DEFENSE LOGISTICS AGENCY

- 1. PRODUCT – QUALITY FRUIT AND VEGETABLES**

III. WEST TEXAS COOPERATIVE

- 1. FOOD PRODUCTS – BEN E. KEITH**
- 2. MEAT PRODUCTS – QUINTEROS**

IV. REGION 19 SERVICE CENTER

- 1. FOOD SERVICE EQUIPMENT/UTENSILS
JAX, NATIONAL RESTAURANT, PASCO
STEPCO**
- 2. LINEN SERVICE – UNIFIRST**
- 3. DISHMACHINE SUPPLIES
CAFETERIA EXTERMINATION – ECO LAB**
- 4. PAPER/CHEMICALS – GRAINER
LAUNDRY, SUN SET, SOUTHWESTERN MILLS**



DEPARTMENT OF
PURCHASING
Education Center
12300 Eastlake Dr.
El Paso, TX 79928-5400
P.O. Box 292800
El Paso, TX 79929-2800
PHN 915.937.0164
FAX 915.937.0170
www.sisd.net

BID AWARD

July 21, 2004

Adele Balesh
Director of Nutrition Service of Canutillo I.S.D.

Socorro Independent School District is pleased to announce the results of the following invitation to bid: Dairy Products, CSP No. 199-0603-0481. Award of this invitation was approved at the regular meeting of the SISD Board of Trustees on July 20, 2004.

Attached is a complete listing of the bid items, the vendor awarded the bid, and the awarded bid price. Please direct any questions to the undersigned.

Thank you for your response to the bid invitation and your continued support of the District.

Regards,

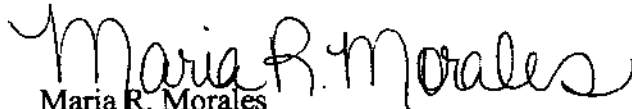
Maria R. Morales
Purchasing Agent

Enclosure



DEPARTMENT OF

PURCHASING

Education Center

12300 Eastlake Dr.

El Paso, TX 79928-5400

P.O. Box 292800

El Paso, TX 79929-2800

PHN 915.937.0164

FAX 915.937.0170

www.sisd.net

BID AWARD

July 21, 2004

Adele Balesh
Director of Nutrition Service of Canutillo I.S.D.

Socorro Independent School District is pleased to announce the results of the following invitation to bid: Mexican Food Products, CSP No. 199-0603-0480. Award of this invitation was approved at the regular meeting of the SISD Board of Trustees on July 20, 2004.

Attached is a complete listing of the bid items, the vendor awarded the bid, and the awarded bid price. Please direct any questions to the undersigned.

Thank you for your response to the bid invitation and your continued support of the District.

Regards,

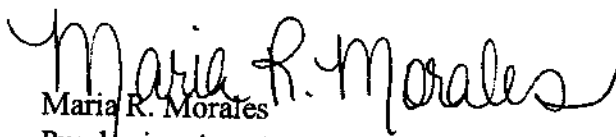
Maria R. Morales
Purchasing Agent

Enclosure



DEPARTMENT OF
PURCHASING
Education Center
100 Eastlake Dr.
Socorro, TX 79928-5400
P.O. Box 292800
Socorro, TX 79929-2800
Phone: 915.937.0164
Fax: 915.937.0170
www.sisd.net

BID AWARD

July 21, 2004

Adele Balesh
Director of Nutrition Service of Canutillo I.S.D.

Socorro Independent School District is pleased to announce the results of the following invitation to bid: Bakery Products, CSP No. 199-0603-0482. Award of this invitation was approved at the regular meeting of the SISD Board of Trustees on July 20, 2004.

Attached is a complete listing of the bid items, the vendor awarded the bid, and the awarded bid price. Please direct any questions to the undersigned.

Thank you for your response to the bid invitation and your continued support of the District.

Regards,

Maria R. Morales
Purchasing Agent

Enclosure



IN REPLY
REFER TO

DEFENSE LOGISTICS AGENCY
PRODUCE BUYING OFFICE FORT WORTH
DEFENSE PERSONNEL SUPPORT CENTER
1313 SAMUELS AVENUE
FORT WORTH, TEXAS 76102

July 9, 2004

Welcome to the Fresh Fruit & Vegetable Program

TDHS has sent me your allocation in the amount of 9,579.77
Your deliveries will be made to the schools you indicated. You may purchase any item on the following availability list that contains only USA grown items with your money. If you wish to purchase Bananas or other foreign grown products you must sign a Section 4-11 agreement and you will receive a bill for those items.

You must have spent half of your allotted money by the Christmas break. If you have not, your money will be removed from your account and given to someone that has spent their monies.

A list of all the items available at this time is enclosed. Please note that almost any item you want is available NOW. A list is also enclosed of the items that will be available from November to May. Please note that the fall list is much smaller because many items are foreign grown during this time frame and are not available with your group A.

We have solicited all approved vendors in the area and feel that

Quality would be your best supplier. Your

delivery day will be Monday. To ensure that everyone in your area is provided with the best possible service, please try to work with the vendor listed above.

WEST TEXAS FOOD SERVICE COOPERATIVE
Food Purchasing Component

Education Service Centers Regions 16, 17, 18 and 19

Date: August 30, 2004

From: Judy Gray
Purchasing Specialist
West Texas Food Service Purchasing Cooperative

To: Food Service Directors

Subject: Bid Award Change

The Food Purchasing Bid Award for Ben E. Keith in Amarillo has been changed to Ben E. Keith in Albuquerque. This change will take effect as of September 1, 2004. Listed below is the contact information for the Albuquerque Division.

Ben E Keith Foods
P.O. Box 26656
Albuquerque, NM 87125
505-843-7766
800-675-2949
505-842-8060 FAX
Contact: Colleen LaClair

All of the bid items will stay the same as well as the pricing. NOTE: All items shipped in August will be paid to the Amarillo Division and the items shipped in September and in the future will be paid to the Albuquerque Division.

A new Food Purchasing Catalog with nutritional information will be sent to you as soon as possible. If you have any questions, please call me at (806) 792-5468 ext. 710 or send me an email at jgray@esc17.net.

WEST TEXAS FOOD SERVICE COOPERATIVE

Food Purchasing Component

Region 16, 17, 18 and 19 Education Service Centers

2004-2005 VENDOR AWARD LIST

The following vendor has been awarded items for the bid period August 1, 2004 through July 31, 2005 in areas A, B, and C.

US Food Service, Inc.
P. O. Box 2804
Lubbock, TX 79408
806/747-5204
1-800-736-6178
806/747-6388 FAX
contact person: Gerald Ward

The following vendor have been awarded items for the bid period August 1, 2004 through July 31, 2005 in area D only.

Quintero's Meat Company
4413 Durazno
El Paso Texas
915/351-2471
915/351-2474 FAX
contact person: Juan Garcia

The following vendor have been awarded items for the bid period August 1, 2004 through July 31, 2005 in area D only.

Ben E. Keith Foods
P. O. Box 1588
Amarillo, TX 79105
806/376-6257 (Amarillo)
1-800-658-9790 (Amarillo)
806/374-8921 FAX (Amarillo)
contact person: Jamie Watkins

**REGION 19 EDUCATION SERVICE CENTER
BID AWARD SUMMARY**

BID TITLE: Linen Services
BID NUMBER: 02-5394
BID OPENING DATE: July 3, 2002
CONTRACT TERM: Date of Award until September 1, 2003 with the option to extend in 12-month increments not to exceed 36 months in the aggregate
(Extended by Region 19 Board of Directors on July 10, 2003 until September 1, 2004)
FUNDING SOURCE: Various
BID'S ISSUED: 6
RESPONSES: 2
ADVERTISEMENT DATES: June 16th & 23rd, 2002
BOARD MEETING DATE: July 11, 2002

RECOMMENDED FOR AWARD: Unifirst Corporation

TOTAL (ESTIMATED) \$100,000.00

EXPLANATIONS:

Award of this contract will enable Region 19 ESC and its Purchasing Cooperative Members to purchase linen and mat rental services for both their Food Service and Maintenance Departments as required. The recommended contractor has the ability to serve all Region 19 Purchasing Cooperative Members and was low bid on 12 of 14 items with the 6% environmental fee added to each invoice as per Unifirst's submittal.

SPECIFICATIONS PROVIDED BY: Royce Cleveland
Region 19 ESC

EVALUATION COMMITTEE: Royce Cleveland
Region 19 Purchasing

Terry Freiburg
El Paso ISD

Adele Balesh
Canutillo ISD

ORDER INFORMATION:

Unifirst Corporation
Attn: Frank Perez
6920 Commerce
El Paso, TX 79915
915-779-3221 (1-800-537-9074)
Fax: 915-778-2810
fperez@unifirst.com

**REGION 19 EDUCATION SERVICE CENTER
BID AWARD SUMMARY**

BID TITLE: Region 19 Cooperative Dishmachine Supplies & Related
BID NUMBER: 03-5581
BID OPENING DATE: July 16, 2003
CONTRACT TERM: Date of Award until September 1, 2004 with the option to extend 12 additional months not to exceed 36 months in the aggregate
(Extended by Region 19 Board of Director on August 13, 2004 until September 1, 2005)
FUNDING SOURCE: Various
BID'S ISSUED: 20
RESPONSES: 4
ADVERTISEMENT DATES: June 22nd and 29th, 2003
BOARD MEETING DATE: August 14, 2003

RECOMMENDED AWARD: Eco Lab
TOTAL (ESTIMATED) \$300,000.00

EXPLANATIONS:

Award of this contract will enable Region 19 ESC and its Purchasing Cooperative Members to purchase commercial dishmachine supplies and service during the contract period. Due to continuity in servicing, troubleshooting, compatibility of products, special conditions stated this bid would be awarded "all or none" in the best interest of the Region 19 Purchasing Cooperative. Due to concentration levels for dishmachine chemicals, true cost analysis is based on the usage cost when these chemicals are diluted with water. It should also be noted that depending on the manufacturer and model, different dish machines use different amounts of water, therefore each dispensing unit has to be calibrated by the vendor to maintain a certain level of chemical concentration to properly clean, sanitize, and dry dishes in compliance with local health ordinances. Eco Lab was low bid on 10 of 15 items, Regal was low bid on 3 of 15 items, and Johnson Diversey was low bid on 2 of 15 items. Additionally, Eco Lab bid on all 15 requested items, while Regal "no bid" 6 of 15 items. Additionally, Chemco "no bid" 4 of 15 items. Eco Lab has the largest staff of employees that would be dedicated to this contract.

SPECIFICATIONS PROVIDED BY: Royce Cleveland
Region 19 Purchasing Manager

EVALUATION COMMITTEE: Terrence Freiburg
El Paso ISD- Director of Purchasing

Adriana Rascon Lopez
Region 19 Head Start Food Nutrition Director

Royce Cleveland
Region 19 Purchasing Manager



**REGION 19 EDUCATION SERVICE CENTER
BID AWARD SUMMARY**

BID TITLE: Region 19 Cooperative Janitorial Supplies & Equipment
BID NUMBER: 04-5734
BID OPENING DATE: July 29, 2004
CONTRACT TERM: September 1, 2004 until August 31, 2005
FUNDING SOURCE: Various
BID's ISSUED: 40
RESPONSES: 20
ADVERTISEMENT DATES: July 15th & 22nd, , 2004
BOARD MEETING DATE: August 13, 2004

RECOMMENDED FOR AWARD

Arspec, Inc. (HUB)- Item #196

Baron Chemical- Items #12, 13, 15, 16, 19, 21, 23, 24, 29, 34, 45, 47, 48, 53, 54, 55, 56, 57, 63, 66, 83, 86, 112, 113, 132, 133, & 134

Grainger- Items #1, 11, 22, 43, 46, 91, 110, 115, 120, 121, 124, & 125

ICS- Items #104 & 105

Interboro Packaging- Items #4, 14, 153, & 154

Laun-Dry Supply Company- Items #2, 18, 33, 38, 41, 42, 44, 67, 70, 75, 76, 77, 114, 126, 138, 142, 143, 151, 158, 162, 164, 167, 170, 175, 184, & 186.

Ryan Supply Inc.- Items #106, 127, 128, 131, & 146

Sepco Inc. dba Springtime Janitorial- Items #30, 31, 37, 50, 60, 78, 80, 81, 85, 87, 107, 111, 119, 199, 200, 201, 202, 203, 204, 205, & 206.

Southwestern Mill Distributors, Inc.- Items #3, 5, 6, 7, 10, 17, 25, 27, 28, 32, 35, 39, 49, 51, 52, 58, 59, 61, 62, 64, 65, 67A, 68, 71, 72, 73, 74, 82, 84, 92, 95, 98, 100, 102, 116, 117, 118, 129, 130, 136, 139, 141, 147, 148, 149, 150, 152, 155, 156, 157, 159, 160, 163, 165, 166, 169, 171, 172, 173, 174, 176, 179, 181, 182, 183, 189, 192, & 195

Spectrum Paper (HUB)- Items #88, 89A, 89B, 89C, 90, 96, 97, 99, 101, 135, & 178.

Sun Set Industries (HUB)- Items #8, 9, 26, 36, 108, 122, 123, 144, 145, 168, 177, 180, 188, 191, 193, 194, 197, & 198

Sunwest Wholesale Merchants (HUB)- Items #69, 79, 93, 94, 103, 109, 140, 161, & 207

ZEP Manufacturing- Item #40

TOTAL (ESTIMATED LESS THAN)

\$1,000,000 / year

CANUTILLO INDEPENDENT SCHOOL DISTRICT
OFFICE OF THE SUPERINTENDENT
POST OFFICE BOX 100
CANUTILLO, TEXAS

Agenda Item:

Date: December 14, 2004

Subject: Furniture and Equipment for new High School

Presented By: Tony Reza

Consent Agenda: ✓

ACTION

1. BACKGROUND INFORMATION:

The Finance Department is reviewing and evaluating proposals for furniture and equipment for the new high school RFP # 05-01. A recommendation will be included in the Friday packet on December 10, 2004.

2. SUPERINTENDENT RECOMMENDATION:

The Superintendent recommends approval of the furniture and equipment as presented in the Friday packet.

3. BOARD ACTION REQUESTED:

The Board of Trustees approves the Superintendent's recommendation.

MOTION _____ SECOND _____

AYES _____ NAYS _____

CANUTILLO INDEPENDENT SCHOOL DISTRICT
OFFICE OF THE SUPERINTENDENT
POST OFFICE BOX 100
CANUTILLO, TEXAS

Agenda Item:

Date: December 14, 2004

Subject: Approval to Award E-Rate 8 Projects

Presented By: Tony Reza

Consent Agenda: ✓

ACTION

1. BACKGROUND INFORMATION:

The Technology Department is reviewing and evaluating proposals for the E-Rate program. A recommendation will be included in the Friday packet on December 10, 2004.

2. SUPERINTENDENT RECOMMENDATION:

The Superintendent recommends approval to award the E-rate project as recommended by the Technology Department.

3. BOARD ACTION REQUESTED:

The Board of Trustees approves the Superintendent's recommendation.

MOTION _____ SECOND _____

AYES _____ NAYS _____

**CANUTILLO INDEPENDENT SCHOOL DISTRICT
OFFICE OF THE SUPERINTENDENT
POST OFFICE BOX 100
CANUTILLO, TEXAS**

Date: December 14, 2004

Subject: Purchase upgrade to enhance the district's SEMS telephone absence tracking system

Presented By: Renee O'Donnell/Martha Veale Consent Agenda: ✓

ACTION

1. BACKGROUND INFORMATION:

Approval to purchase upgrade to enhance the tracking system at an approximate cost of \$15,138.33. Enhancement product enables employees to report absences either by telephone or via computer using the Internet.

Our existing SEMS absence tracking system is at the point that the District must add additional telephone lines in order to accommodate all the calls to the system. The existing phone lines accommodate up to 500 employees and employees now experience long wait times due to the ongoing busy signals. To correct the problem of tied-up lines, the District needs to purchase additional phone lines. SEMS sells these lines in bundles of four at a total of approximately \$11,000 plus \$30.00 a month per line (\$360 per year per line).

2. SUPERINTENDENT RECOMMENDATION:

Rather than add more telephone lines, the Human Resources Department would like to upgrade our present SEMS telephone absence tracking system and add the SEMS WebCenter at a cost of approximately \$15,138.33. This would allow district employees to use either the telephone or the Internet to report absences. This will not only reduce the number of busy signals we now experience but also provide additional needed features to the system such as:

- Allow employees the flexibility to use either a telephone or the Internet to report absences and request a substitute, if needed.

- Allow employees and supervisors to review and print historical absence data.
- Allow principals and supervisors to view past, current, and future jobs at their individual locations.
- Allow principals and supervisors to reassign jobs giving them greater control over selecting substitutes and filling assignments.
- Allow principals and supervisors to view and print reports.
- Allow substitutes to search for multiple jobs without having to take action on each individual job, review historical data, and print assignment records.
- Allow substitutes to modify their call back number and availability data.

The Human Resources Department has submitted budget amendments to cover the cost of the implementation, pending Board approval.

3. BOARD ACTION REQUESTED: '

Motion to approve the purchase upgrade to enhance the SEMS telephone absence tracking system as recommended by the Superintendent.

MOTION _____ SECOND _____

AYES _____ NAYS _____

**CANUTILLO INDEPENDENT SCHOOL DISTRICT
OFFICE OF THE SUPERINTENDENT
POST OFFICE BOX 100
CANUTILLO, TEXAS**

Date: December 14, 2004

Subject: Interlocal Agreement with Village of Vinton regarding the Safe & Drug Free Schools and Community Grant

Presented By: Pam Padilla/Larry Baskind

Consent Agenda: 

ACTION

1. BACKGROUND INFORMATION:

This interlocal agreement was drafted by the school district's legal counsel. This interlocal agreement is intended to provide certain services to at-risk children and their families in the Upper Valley of El Paso County. Services will be provided by Canutillo ISD through the use of Childress Elementary office space. Other services provided by the school district are enumerated in the document.

2. SUPERINTENDENT RECOMMENDATION:

Recommend approval of the interlocal agreement with the Village of Vinton.

3. BOARD ACTION REQUESTED:

Motion to approve the Interlocal Agreement with Village of Vinton as recommended by the Superintendent.

MOTION _____ SECOND _____

AYES _____ NAYS _____

BASKIND & HOSFORD, P.C.
ATTORNEYS AT LAW
300 E. Main, Suite 908
El Paso, Texas 79901-1379

LARRY A. BASKIND
HENRY C. HOSFORD, JR.*
MARK SALLOUM

Telephone:(915) 544-0737
Facsimile: (915) 533-5021

*ALSO ADMITTED IN NEW MEXICO

MEMORANDUM

TO: Jose Lopez
Canutillo ISD
FAX: 877-7470

FROM: Larry A. Baskind

RE: Interlocal Agreement Between Canutillo ISD
and Village of Vinton

DATE: November 10, 2004

Please find enclosed a draft of the proposed Interlocal Agreement. Please review and provide any comments. If you are satisfied with the form of the Interlocal Agreement, I can email it to you so that you can make any minor revisions or corrections needed. Please feel free to forward this to the Village of Vinton for its review.

I do want to point out that I made a couple of minor changes to your list of duties. With respect to the providing student data, there is federal and state law on what data can be provided. We need to be sure we comply with this law as certain information cannot be provided without parental consent. I also want to be sure that all of the people retained are not employees but are independent contractors. We will need to coordinate with the purchasing department in order to comply with applicable law.

THE INFORMATION CONTAINED IN THIS FACSIMILE MESSAGE IS ATTORNEY PRIVILEGED AND CONFIDENTIAL INFORMATION INTENDED ONLY FOR THE USE OF THE INDIVIDUAL OR ENTITY NAMED ABOVE. IF THE READER OF THIS MESSAGE IS NOT THE INTENDED RECIPIENT, OR THE EMPLOYEE OR AGENT RESPONSIBLE TO DELIVER IT TO THE INTENDED RECIPIENT, YOU ARE HEREBY NOTIFIED THAT ANY DISSEMINATION, DISTRIBUTION OR COPYING OF THIS COMMUNICATION IS STRICTLY PROHIBITED. IF YOU HAVE RECEIVED THIS COMMUNICATION IN ERROR, PLEASE DESTROY IMMEDIATELY AND NOTIFY US BY TELEPHONE AND/OR RETURN THE ORIGINAL MESSAGE TO US AT 300 E. MAIN, SUITE 908, EL PASO, TEXAS 79901 VIA THE US POSTAL SERVICE. F:\LBAS\2004\CJSD\CORRSP\MEMO\Lopez.1

**INTERLOCAL AGREEMENT BETWEEN
CANUTILLO INDEPENDENT SCHOOL DISTRICT
AND VILLAGE OF VINTON**

This Interlocal Agreement (this "Agreement") is made between CANUTILLO INDEPENDENT SCHOOL DISTRICT (the "Canutillo ISD") and VILLAGE OF VINTON ("Vinton") as of this ____ day of _____, 2004.

1. Recitals.

Whereas, Vinton has received approval for a grant (the "Grant") in the amount of \$50,000.00 pursuant to the Safe and Drug Free Schools and Communities Act to provide certain services to at risk children and their families in the Upper Valley of El Paso County, Texas; and

Whereas, Vinton has requested Canutillo ISD to provide certain services contemplated by the Grant, to base the services from the Childress Elementary School, and utilize the resources and the infrastructure of the Department of Student and Community Services at Canutillo ISD;

Whereas, Canutillo ISD and Vinton are authorized to enter into Interlocal Agreements pursuant to Section 791.001, Texas Government Code; and

Whereas, the services provided through this Interlocal Agreement will provide efficiencies and cost savings to both Canutillo ISD and Vinton and will benefit their respective residents, students and taxpayers;

NOW, THEREFORE, for and in consideration of the recitals, agreements and covenants set forth herein, the parties hereby agree as follows:

2. Duties and Responsibilities of Canutillo ISD. Canutillo ISD shall have the following duties and obligations:

- Provide onsite coordination, an adequate project site, and office space at Bill Childress Elementary School.
- Utilize Project Link to identify appropriate students for referral.
- Provide a well-planned environment of socialization, exercise, arts, crafts, educational field trips, and games to help stimulate mental and physical abilities for the reduction and prevention of drug and/or alcohol abuse.
- Obtain parental permission for student participation and coordinate meetings between mentors and students.
- Assist with volunteer and student orientation, training, and mentor and youth matching.

- To the extent allowed by applicable law, provide appropriate participants, such as program evaluators, with student data and ensure participant anonymity.
- Assist with the preparation of evaluations and quarterly reports.
- Contract with a full-time project coordinator who will be the point of contact.
- Provide or contract with personnel who will maintain casework for the ongoing project and participate in monitoring.
- Track outcomes and prepare evaluations and quarterly reports.
- Provide training programs in the identification, intervention and prevention of substance and/or alcohol abuse.
- Provide "Drug and Violence Free" activities for Vinton community members.
- Cooperate to the fullest extent possible with the Safe and Drug Free Schools and Communities Grant through the Texas Governor's Office.

3. Duties and Responsibilities of Vinton. The duties and obligations of Vinton shall be as follows:

- On a monthly basis, reimburse the Canutillo Independent School District for costs incurred by the program as stipulated in the Grant budget.
- Coordinate with local agencies by providing information and opportunities to prevent and reduce drug and/or alcohol abuse.
- Submit Financial and Progress reports to the Texas Governor's Office in a timely manner.
- Promote information sharing and the coordination of activities to improve the performance of all partners.
- Exchange information and coordinate programs for a more streamlined and efficient system.
- Identify opportunities for coordination and to eliminate barriers to reduce alcohol and/or drug abuse.
- Cooperate to the fullest extent possible with the Grant through the Texas Governor's Office.

4. Consultants and Independent Contractors. In order to provide the staffing for the services and activities contemplated by the Grant, Canutillo ISD will retain or contract with certain consultants and independent contractors to perform most of the services required by the Grant. The School District will follow its normal purchasing procedures for selection of consultants and independent contractors to conduct these services in accordance with Section 44.031, Texas Education Code, and shall enter into contracts or agreements with the consultants and independent contractors who are hired. All expense of the consultants and independent contractors shall be considered an expense of the Grant program. The School District shall be reimbursed by Vinton out of Grant proceeds for such expense. The consultants and independent

contractors hired shall not be deemed employees of Canutillo ISD.

5. Compliance with Grant. A copy of the application for the Grant and award of Grant is attached hereto as Exhibit A. To the extent any provisions of this Agreement are inconsistent with the terms, conditions, covenants and provisions of the Grant, the Grant shall control. The parties shall strictly comply with the terms and conditions of the Grant in the performance of activities and services to the community contemplated by the Grant.

6. Term. The term of this Interlocal Agreement shall be one (1) year commencing on September 1, 2004 and concluding on August 31, 2005. Either Canutillo ISD or Vinton may terminate this Agreement at any time, with or without cause, with thirty (30) days written notice to the other party.

7. Liability. This Agreement is not intended to alter or reallocate any defense or immunity presently authorized by law, or to create or transfer any liability arising under the law. Canutillo ISD and Vinton shall each bear any liability or risk of loss for claims arising from the acts or omissions of their respective employees and agents. Each party agrees that it shall be responsible for its own officers, agents and employees who are performing duties under this Agreement, and neither shall be liable or responsible for the acts or omissions of the other's officers, agents or employees.

7. Miscellaneous.

A. Entire Agreement. This Agreement constitutes the entire agreement of the parties and supercedes all prior agreements or understandings, whether written or oral.

B. Notices. Any notice authorized or required to be given under this Agreement shall be delivered or sent to the following addresses:

Canutillo ISD
 P.O. Box 100
 Canutillo, Texas 79835
 Attn: Superintendent

Village of Vinton

 Village of Vinton, Texas 79____
 Attn: Mayor

C. Compliance with Law and Regulations. The parties agree to comply with all applicable local, state and federal laws, ordinances, regulations and orders.

D. Governing Law. This Agreement shall be governed in all respects in accordance with the laws of the State of Texas, and shall be enforceable in El Paso County, Texas.

E. Counterparts. This Agreement is being executed in multiple counterparts, each of which shall constitute an original and of which together shall constitute but one and the same instrument.

SIGNED AND APPROVED as of the date shown above.

CANUTILLO ISD:

CANUTILLO INDEPENDENT SCHOOL DISTRICT

BY: _____
CHARLES HART, SUPERINTENDENT

VINTON:

VILLAGE OF VINTON

BY: _____
_____, **MAYOR**

**CANUTILLO INDEPENDENT SCHOOL DISTRICT
OFFICE OF THE SUPERINTENDENT
POST OFFICE BOX 100
CANUTILLO, TEXAS**

Date: December 14, 2004

Subject: Interlocal Agreement with Village of Vinton to share maintenance, personnel and equipment

Presented By: Larry Baskind Consent Agenda: ✓

ACTION

1. **BACKGROUND INFORMATION:**

This interlocal agreement was drafted by the attorney for the Village of Vinton. This interlocal agreement is intended to allow the Village and School District to share maintenance, personnel and equipment, if needed.

2. **SUPERINTENDENT RECOMMENDATION:**

Recommend approval of the interlocal agreement with the Village of Vinton.

3. **BOARD ACTION REQUESTED:**

Motion to approve the Interlocal Agreement with Village of Vinton as recommended by the Superintendent.

MOTION _____ SECOND _____

AYES _____ NAYS _____

BASKIND & HOSFORD, P.C.

ATTORNEYS AT LAW

**300 E. MAIN, SUITE 908
EL PASO, TEXAS 79901-1379**

**LARRY A. BASKIND
HENRY C. HOSFORD, JR.*
MARK SALLOUM**

*ALSO ADMITTED IN NEW MEXICO

**Telephone: (915) 544-0737
Facsimile: (915) 533-5021**

FACSIMILE TRANSMITTAL

FAX #

**TO: Charles Hart
Superintendent
Canutillo ISD** **877-7414**

FROM: Larry A. Baskind

DATE: December 3, 2004

RE: Interlocal Agreement with Village of Vinton

**NO. OF PAGES: 5
(including cover sheet)**

SPECIAL INSTRUCTIONS:

THE INFORMATION CONTAINED IN THE FOLLOWING FACSIMILE MESSAGE IS ATTORNEY PRIVILEGED AND CONFIDENTIAL INFORMATION INTENDED ONLY FOR THE USE OF THE INDIVIDUAL OR ENTITY NAMED ON THE ATTACHED COVER SHEET. IF THE READER OF THIS MESSAGE IS NOT THE INTENDED RECIPIENT, OR THE EMPLOYEE OR AGENT RESPONSIBLE TO DELIVER IT TO THE INTENDED RECIPIENT, YOU ARE HEREBY NOTIFIED THAT ANY DISSEMINATION, DISTRIBUTION OR COPYING OF THIS COMMUNICATION IS STRICTLY PROHIBITED. IF YOU HAVE RECEIVED THIS COMMUNICATION IN ERROR, PLEASE IMMEDIATELY NOTIFY US BY TELEPHONE AND RETURN THE ORIGINAL MESSAGE TO US AT 300 E. MAIN, SUITE 908, EL PASO, TEXAS 79901 VIA THE U.S. POSTAL SERVICE. THANK YOU. F:\BAS\2004\CISD\CRRSP\FaxCoverHart2

BASKIND & HOSFORD, P.C.
ATTORNEYS AT LAW
300 E. MAIN, SUITE 908
EL PASO, TEXAS 79901-1379

J. LARRY A. BASKIND
HENRY C. HOSFORD, JR.*
MARK SALLIDUM

TELEPHONE: (915) 544-0737
FAX: (915) 533-5021

***ALSO ADMITTED IN NEW MEXICO**

December 3, 2004

VIA FAX 877-7414

Mr. Charles Hart
Superintendent
Canutillo ISD
P.O. Box 100
Canutillo, Texas 79835

RE: Proposed Interlocal Agreement Between the Village of Vinton
and Canutillo ISD

Dear Mr. Hart:

Please find enclosed an Interlocal Agreement drafted and submitted by the attorney for the Village of Vinton for consideration by the School District. This Interlocal Agreement allows the Village and School District to share maintenance, personnel and equipment if needed and is in the best interest of both parties. The Mayor of Vinton has recommended this and instructed the Village's attorney to draw up this agreement. If the form of the Agreement is acceptable, I would respectfully request that this be considered as an agenda item for either the December or January meeting.

Very truly yours,



LARRY A. BASKIND

LAB:ogt

Enclosure

FM.BAS/2004CISD/CRR/SV/lhr.1?

- specific written request shall not be required in the case of emergencies when a written request is not feasible.
- 3.2 The written request to borrow and the authorization to lend maintenance personnel and/or equipment must specify the scope of the work for which the personnel/equipment will be utilized.
- 3.3 The borrowing entity shall be wholly responsible for all risks and hazards inherent in or reasonably foreseeable in the use, transportation and maintenance of the equipment and the lending entity shall have no liability therefore whatsoever and shall be held harmless therefrom by the borrowing entity.
- 3.4 Any borrowed equipment must be operated exclusively by a qualified equipment operator.
- 3.5 No expenditure of funds shall be made pursuant to this Agreement without specific written authorization from the paying party, with the exception of reasonable expenditures necessary to operate and maintain the equipment which shall be paid by the borrowing entity.
- 3.6 Each party paying for the performance of governmental functions or services must make those payments from current revenues available to the paying party.

4.0 MISCELLANEOUS

- 4.1 The document contains the entire agreement between the parties. Any oral representation or modification concerning this Agreement shall be of no force excepting a subsequent amendment in writing signed by each party.
- 4.2 This Interlocal Agreement may be amended only by mutual agreement of the parties in writing signed by both parties, to be attached to and incorporated herein.
- 4.3 If any action is brought with regard to this Agreement, in addition to any other relief which may be awarded, the prevailing party shall be entitled to recover attorney's fees and costs from the other party.
- 4.4 This Agreement is entered into in El Paso, County, Texas and venue for the enforcement of this Agreement shall lie in El Paso, County, Texas.
- 4.5 In the event any portion of this Agreement shall be found invalid or unenforceable, the remaining terms and conditions shall remain in full force and effect.
- 4.6 This Agreement may not be assigned by any party in whole or part.

IN WITNESS WHEREOF, the Parties have executed this Interlocal Agreement in duplicate counterparts, both having equal force, and effective on the date written above.

VILLAGE OF VINTON, TEXAS

CANUTILLO INDEPENDENT SCHOOL DISTRICT

Juvencia Rios-Ontiveros, Mayor
Village of Vinton

Jose Villarreal, President, Board of Trustees
Canutillo Independent School District

ATTEST:

ATTEST:

Refugia (Cooky) Marshall, Village Clerk

Frank Lerma, Secretary

Approved as to form:

Approved as to form:

Shane A. English, Village Attorney

Larry A. Baskind, Attorney for Canutillo
Independent School District

**CANUTILLO INDEPENDENT SCHOOL DISTRICT
OFFICE OF THE SUPERINTENDENT
POST OFFICE BOX 100
CANUTILLO, TEXAS**

Date: December 14, 2004

Subject: Interlocal Agreement with El Paso ISD regarding El Paso County Juvenile Justice Alternative Education Program

Presented By: Charles Hart Consent Agenda: ✓

ACTION

1. BACKGROUND INFORMATION:

This interlocal agreement is approved on a yearly basis. This agreement is intended to authorize the transfer of students expelled from Canutillo ISD to the JJAEP Program operated by El Paso ISD.

2. SUPERINTENDENT RECOMMENDATION:

Recommend approval of the interlocal agreement with El Paso ISD.

3. BOARD ACTION REQUESTED:

Motion to approve the Interlocal Agreement with El Paso ISD as recommended by the Superintendent.

MOTION _____ SECOND _____

AYES _____ NAYS _____

**INTERLOCAL AGREEMENT BETWEEN DISTRICTS REGARDING
THE EL PASO COUNTY JUVENILE JUSTICE
ALTERNATIVE EDUCATION PROGRAM PURSUANT TO CHAPTER 37 OF
THE TEXAS EDUCATION CODE**

The El Paso Independent School District, hereinafter called "EPISD," and the Canutillo Independent School District, hereinafter called "CISD," enter into this Inter-local Agreement effective this 1st day of September, 2004.

Texas Government Code Chapter 791 authorizes political subdivisions of the State to enter into contracts to increase their efficiency and effectiveness by consolidation of the administrative functions of government. The parties hereto are both political subdivisions of the State and hereto enter this Agreement in furtherance thereof.

This Agreement is intended to authorize the transfer of students expelled from the CISD to the JJAEP Program operated by the EPISD.

I.

A. The EPISD is operating, pursuant to an Inter-local Agreement with the County of El Paso by and through the El Paso County Juvenile Board, the Juvenile Justice Alternative Education Program ("JJAEP") pursuant to Chapter 37 of the Texas Education Code for students expelled from the El Paso, Anthony and Canutillo Independent School Districts, pursuant to §37.007 (a), (d) and (e) of the Texas Education Code. Pursuant to said Interlocal Agreement, the EPISD shall operate the JJAEP program for students expelled from CISD pursuant to said Education Code sections, provided that CISD joins said Interlocal Agreement and complies with all of the requirements thereof, and provided that EPISD receives from El Paso County Juvenile Board the funding in the amount of \$59.00 per day per student contemplated therein. The obligations

of EPISD in operating the JJAEP Program for the benefit of such students are as discussed in said Interlocal Agreement.

B. With respect to any students expelled by CISD pursuant to §37.007 (b), (c), or (f) (“discretionary expulsions”), if CISD desires that said students be placed in the JJAEP operated by the EPISD, such students may be accepted by the EPISD to the JJAEP, on a case-by-case basis. Because, pursuant to the El Paso County Inter-local Agreement, the Juvenile Board need not provide any additional funding for discretionary expulsion students, the CISD will pay to the EPISD an annual fee of \$7,500 per student for each discretionary expulsion student accepted by the EPISD into the JJAEP. Said fee is payable upon acceptance of the student by the EPISD into the JJAEP, is not refundable, and will cover the student’s education in the JJAEP for the duration of the expulsion term, or until August 31, 2005, whichever first occurs. All payments by CISD hereunder will be made from current revenues available to it.

C. With respect to CISD discretionary expulsion students attending the JJAEP under this Agreement, the CISD agrees to:

1. Transfer the student to the EPISD for the duration of the student’s attendance at the JJAEP so that the EPISD will be entitled to receive the WADA allotment from the State of Texas.
2. Transport the students to their assigned alternative campus at the CISD’s expense.
3. Obtain from the parents, the appropriate person, or anyone standing in parental relation to the student, a transfer form required by the EPISD.
4. Assignment of special education students must be preceded by a consensus of such assignment by sending and receiving ARD Committees, a transfer executed by the parent or other legal guardian of the student, and formal determination that the existing facilities of the site proposed for transfer meets the needs of the student to be placed, and shall be subject to the other terms and

conditions relative to special education students set out in the El Paso County Inter-Local agreement and in §37.004 of the Texas Education Code. The CISD shall provide the administrator of the EPISD JJAEP or designee with reasonable notice of the meeting of the student's ARD Committee to discuss the student's expulsion. A representative of the EPISD JJAEP may participate in the meeting to the extent that the meeting relates to the student's placement in the program. If, after placement of a student in the EPISD JJAEP, the administrator of the program, or the administrator's designee, has concerns that the student's education or behavioral needs cannot be met in the program, the administrator, or designee, shall provide written notice of those concerns to the CISD. The student's CISD ARD committee shall meet to reconsider the placement of the student in the program. The CISD shall provide the JJAEP administrator or designee with reasonable notice of the meeting, and a representative of the JJAEP may participate in the meeting to the extent that the meeting relates to the student's continued placement in the program.

D. With respect to CISD discretionary expulsion students attending the JJAEP under this Agreement, the EPISD agrees to:

1. Provide educational services for such students at the Raymond Telles Academy/Dr. Lorenzo G. LaFarelle Alternative Middle School in El Paso Texas.
2. Reserve five student slots for middle and five slots for high school students being transferred under this agreement from CISD. Any additional discretionary expulsion transfer students will be accepted only on a space available basis.
3. Apply to CISD students assigned to the JJAEP Program at the Raymond Telles Academy/Dr. Lorenzo G. LaFarelle Alternative Middle School the same rules and afford the same educational opportunities as provided and delivered to the EPISD students assigned to the aforementioned campus under the same circumstances.
4. Make lunch available for purchase for each student attending the Raymond Telles Academy/Dr. Lorenzo G. LaFarelle Alternative Middle School under this Agreement. Each student will be responsible for the purchase of lunch, except to the extent that lunch is provided on a free or reduced-price basis pursuant to the Federal Free and Reduced Price Lunch Program.

II.

CISD agrees that the EPISD may submit a grant application for whatever funding may be available for the operation of a JJAEP Program.

III.

CISD agrees that EPISD shall have the right to remove a discretionary expulsion student from the JJAEP for cause and return said student to CISD. In the event of such removal, EPISD shall make a pro rata refund of the fee paid by the CISD, prorating the \$7,500 fee over the duration of time that the student was attending the EPISD-operated JJAEP as compared to the duration of the expulsion term or until August 31, 2005, whichever would first occur.

IV.

Upon execution hereof, the CISD shall notify EPISD who its authorized representative will be under this Agreement. The CISD's authorized representative shall contact EPISD Associate Superintendent Robert Ortega, or his designee, when seeking to transfer a student to Raymond Telles Academy. The CISD's authorized representative shall contact EPISD Associate Superintendent Dr. Linda Holman or her designee, when seeking to transfer a student to Dr. Lorenzo G. LaFarelle Alternative Middle School. At the time of Placement or as soon thereafter as practical, CISD shall submit all necessary documentation, student records, and fees.

V.

This Contract shall be in effect until August 31, 2005, or until such time as the Inter-local Agreement for the Establishment and Operation of El Paso County Juvenile Justice Alternative Education Program Pursuant to Chapter 37 of the

Texas Education Code between the County of El Paso and the El Paso Independent School District is terminated, whichever first occurs.

Effective on the date first above noted following formal adoption by the Boards of Trustees of the parties as confirmed by the signatures of their authorized representatives:

EL PASO INDEPENDENT SCHOOL DISTRICT

By:

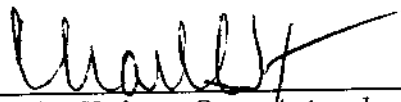

Charles Tafoya, Superintendent

CANUTILLO INDEPENDENT SCHOOL DISTRICT

By:

Charles Hart, Superintendent

DATED: _____

**CANUTILLO INDEPENDENT SCHOOL DISTRICT
OFFICE OF THE SUPERINTENDENT
POST OFFICE BOX 100
CANUTILLO, TEXAS 79835**

Date: December 2004.

Subject: Approval to Purchase District-Wide Extended Warranties for Servers.

Presented By: Martha Veale .Consent Agenda ✓

ACTION

1. BACKGROUND INFORMATION

As stated in Board Policy CH(Local), any single-item purchase that costs more than \$10,000 shall require Board approval before a transaction may take place. This request is to purchase warranty services for district-wide servers. This purchase will be done through DELL Service Sales in the amount of \$20,446.00.

2. SUPERINTENDENT RECOMMENDATION

The superintendent recommends approval to purchase the warranty services for district-wide servers from DELL Service Sales.

3. BOARD ACTION REQUESTED

The Board of Trustees approves the purchase of warranty services for district-wide servers from DELL Service Sales at a cost of \$20,446.00 as recommended by the Superintendent.

MOTION _____

SECOND _____

FOR _____

AGAINST _____

DELL Service Sales

QUOTATION

Dell Service Sales

Quote #: 155293 Date: Nov 16, 2004

Customer Information

Co #: CAMUJILLO ISD

Company Name: CAMUJILLO ISD

Contact: LEROY ROMERO

E-mail: 1747276

Dell Customer #

Dell Service Sales Detail

Description of Service Contract Types	
4HR	4HR 7x24 Service
6HR	2HR 7x24 response, 6 Hr Guaranteed Fix
NO, NBD	Next Business Day Onsite Service
RR, RTD	Return To Dell
CC	Complete Care Service
NA, NC	Not Applicable, No Contract
EOL	End Of Life

NOTE: Dell Service Sales is a separate division of Dell located in CA. Please include the following vendor information on your order.

DELL SERVICE SALES
PO Box 22130
Oakland, CA 94623

Service Tag	Model	Service Contract Type	Ship Date	Service Contract Expiration	Start Date	End Date	Year Service Othering	Price
9RZX401	Power Edge 4400	4 Hr. Support/8x10	10/24/2000	10/23/2004	11/16/2004	10/23/2005	4 Hr. Support/8x10	\$ 893.00
8RZX401	Power Edge 4400	4 Hr. Support/8x10	10/24/2000	10/23/2004	11/16/2004	10/23/2005	4 Hr. Support/8x10	\$ 893.00
18ZX401	Power Edge 4400	4 Hr. Support/8x10	10/24/2000	10/23/2004	11/16/2004	10/23/2005	4 Hr. Support/8x10	\$ 893.00
BRZX401	Power Edge 4400	4 Hr. Support/8x10	10/24/2000	10/23/2004	11/16/2004	10/23/2005	4 Hr. Support/8x10	\$ 893.00
JRZX401	Power Edge 4400	4 Hr. Support/8x10	10/24/2000	10/23/2004	11/16/2004	10/23/2005	4 Hr. Support/8x10	\$ 893.00
HRZX401	Power Edge 4400	4 Hr. Support/8x10	10/24/2000	10/23/2004	11/16/2004	10/23/2005	4 Hr. Support/8x10	\$ 893.00
<p>Reinstatement Fees are attached to all equipment that has an expired service contract</p> <p>All pricing is to extend the existing or expired service type by one or two years or to a maximum of 5 years from purchase END OF LIFE</p>								<p>Total Price: \$6,388.00</p> <p>Reinstatement fee included in Total Price: \$0.00</p> <p>*This quotation is valid for 30 days.</p>

Online tool allows you to track and manage your assets so that you can maintain your services on your existing initial base. Simply register for the free Premier account and then select My Systems.

Link to Premier Support: <http://premier.support.dell.com/ask/en/home.asp>

Asset Value Recovery: If your used equipment has some remaining value, Dell will make a reset offer for the hardware based on a set value schedule. Reclaimable value gained from the equipment's sale will be returned to YOU.

Click here to learn more about Asset Recovery and Value Recovery

Purchase Order Requirements

- > If you will be making your purchase with a purchase order, please ensure it includes the following:
- > Vendor information includes: **Dell Service Sales, PO Box 22130, Oakland, CA 94623**
- > A complete Billing Address;
- > A complete Shipping Address, including a contact name and phone number;
- > The Terms stated as, 'Net 30';
- > A total dollar amount for the PO;
- > An Authorizing Signature (if applicable);
- > And please attach this **Dell Service Sales Quotation** to your PO.
- > Fax your Purchase Order to (831) 430-3443
- > ATT: Dell Service Sales Thank you!

If you have any other questions, please contact me.

JENNIFER DONKERS

Dell Service Sales

Ph: (866)739-3355 ext. 3422

Fax: (831)430-3443

E-mail: jennifer.donkers@dellservicesales.com

Explanation of Service Levels:

Next Business Day:

Place a Dell-trained technician with replacement part at your location the following business day, if necessary, following phone-based troubleshooting. NBD Service is available for up to five years for most systems and can be purchased at a reduced price if purchased within 30 days of the system invoice date. (Calls dispatched before 5:00 pm local customer time, will receive a response on the next business day. In the case of calls dispatched after 5:00 pm local customer time, the service technician may take an additional business day to arrive at your location.)

Link to contract details: [NBD Service Contracts](#)

Same Day Response: A Dell-trained technician may arrive on-site, if necessary, within a select area prior to the next business day. Availability within a 175-mile radius of our AI headquarters office. Provisions not included within a 175-mile radius of the

7324: Dell will dispatch a technician, if necessary after phone-based troubleshooting, to the customer site within 4 hours of determining the hardware problem.

Link to contract details:

[Same Day Response Service Contracts](#)

Silver Enterprise Support: Silver Same Day Basic response simplifies the support process by offering both hardware and software support. Obtain incident resolutions quickly and conveniently by having hardware and software problems analyzed simultaneously. Save time by not having to coordinate support across multiple vendors.

Link to contract details:

[Silver Enterprise Support](#)

Gold Enterprise Support: Engineer-to-Engineer Support with direct access to Dell's entry-level Gold Queue Technical Account Management Team for advanced support and escalation management. Customer-Defined Call Priority so that you maintain control of your case. On-Demand Engineer Dispatch for select Severity 1 incidents to quickly receive on-site services.

Link to contract details:

[Gold Enterprise Support](#)

QUOTATION

Dell Service Sales

Date: November 8, 2004

Dell Service Sales Quote # : 10816272

Customer Information

Co. # : 26

Company Name : CANUTILLO ISD

Contact :

Dell Customer # : 21232818

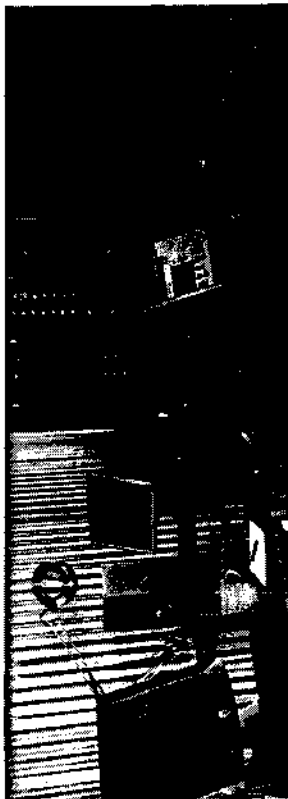

Dell Service Sales Detail

NOTE: Dell Service Sales is a separate division of Dell located in Scotts Valley, CA
Please include the following Remit to information on your order:

**DELL SERVICE SALES
PO BOX 22130
OAKLAND, CA 94623**

Please contact, with questions.

Description of Service Contract Types
S9 4HR 7X24 Service
6HR 2HR 7X24 response, 6 Hr Guaranteed
ND, NBD Next Business Day Onsite Service
RR, RTD Return To Dell
CCO Complete Care Service
NA, NC Not Applicable, No Contract
EOL End Of Life*

Current Equipment Information

Service Tag #	Model	Current Contract Type	Ship Date	Curr. Contract Expiration	New Contract Type		Reinstatement Fees	
					1 Year	2 Years		
3RB8F11	PE 4600	S9 Pes Gold	4/19/2002	4/19/2005	S9 Pes Gold	\$2,416.00	\$3,066.00	NA
FHN8F11	PE 4600	S9 Pes Gold	4/22/2002	4/22/2005	S9 Pes Gold	\$2,416.00	\$3,066.00	NA
CRB8F11	PE 4600	S9 Pes Gold	4/19/2002	4/19/2005	S9 Pes Gold	\$2,416.00	\$3,066.00	NA
2HSYH11	PE 2500	NBD	5/23/2002	5/23/2005	NBD	\$296.00	\$372.00	NA
3HSYH11	PE 2500	NBD	5/23/2002	5/23/2005	NBD	\$296.00	\$372.00	NA
JHN8F11	PE 4600	S9 Pes Gold	4/22/2002	4/22/2005	S9 Pes Gold	\$2,416.00	\$3,066.00	NA
CHN8F11	PE 4600	S9 Pes Gold	4/22/2002	4/22/2005	S9 Pes Gold	\$2,416.00	\$3,066.00	NA
2JN8F11	PE 4600	S9 Pes Gold	4/22/2002	4/22/2005	S9 Pes Gold	\$2,416.00	\$3,066.00	NA

Subtotal	\$15,088.00	\$19,140.00
Reinstatement Fees	\$0.00	\$0.00
Total:	\$15,088.00	\$19,140.00

* Price Valid thru 12/20/04 (per SM)

*Pricing does not include sales tax where applicable

*EOL is five years from Ship Date

Reinstatement Fees are attached to all equipment that has an expired service contract
All pricing is to extend the existing or expired service type by one or two years
or to a maximum of 5 years from purchase END OF LIFE)

This quotation is valid thru 12/20/04 per SM

Online tool allows you to track and manage your assets so that you
can maintain your services on your existing install base. Simply
register for the free Premier account and then select My Systems.



Link to Premier Support: <http://premiersupport.dell.com/us/en/home.asp>

ADMA

Network Rack

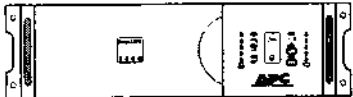
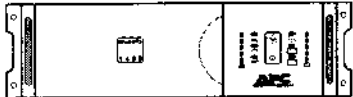
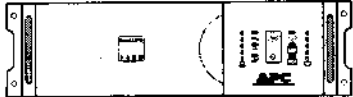
Application Rack

RACK #1 - 42U		
UPS - 1S	Tape Backup Unit US-31340-09L-3033	= 4U
UPS - 1M	Bess Server 3RB8F11	= 6U
UPS - 1S	Active Directory Server FHN8F11	= 6U
UPS - 2M	Mail Server CRB8F11	= 6U
UPS - 2S	DNS - Out H64F021	= 2U
UPS - 2S	DNS - In G64F021	= 2U
UPS - 2S	Flat Monitor	= 1U
	Space - 2 U	= 2U
UPS - 2S	Web Server GVNCX21	= 2U
UPS - 1S	McAfee	= 1U
UPS - 1		= 3U
UPS - 2		= 3U
UPS - 3		= 3U

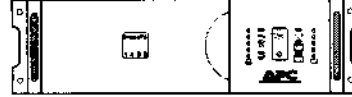
RACK #2 - 42U		
UPS - 1M	FileMaker Server 2HSYH11	= 5U
UPS - 1S	AVATAR Server 3HSYH11	= 5U
UPS - 2M	Streaming Server JHN8F11	= 6U
UPS - 2S	SQL Server CHN8F11	= 6U
	Space - 2U	= 2U
UPS - 3S	Flat Monitor	= 1U
UPS - 3S	Baby Server - 1 U 7LZX401	= 1U
	Space - 1 U	= 1U
UPS - 3M	Active Directory Server II 2JN8F11	= 6U
UPS - 1		= 3U
UPS - 2		= 3U
UPS - 3		= 3U

Network Rack

RACK #3 - 42U

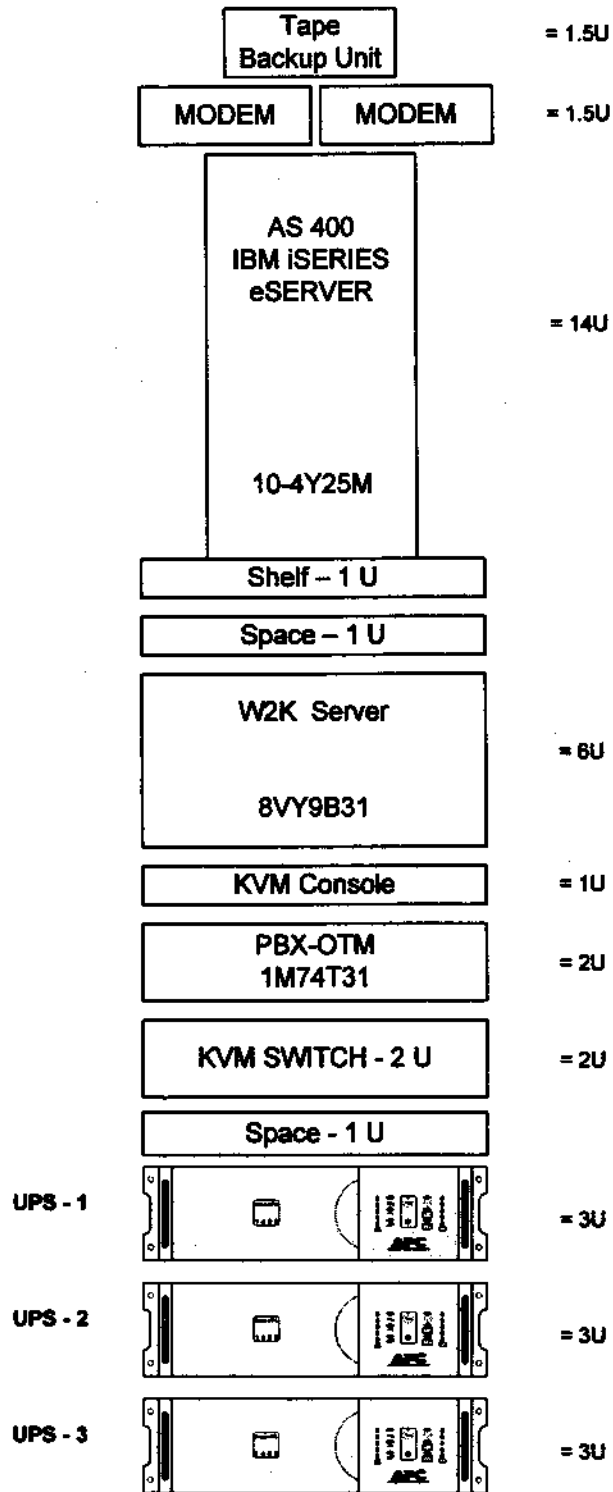

CHS Server Rack

RACK #1 - 42U

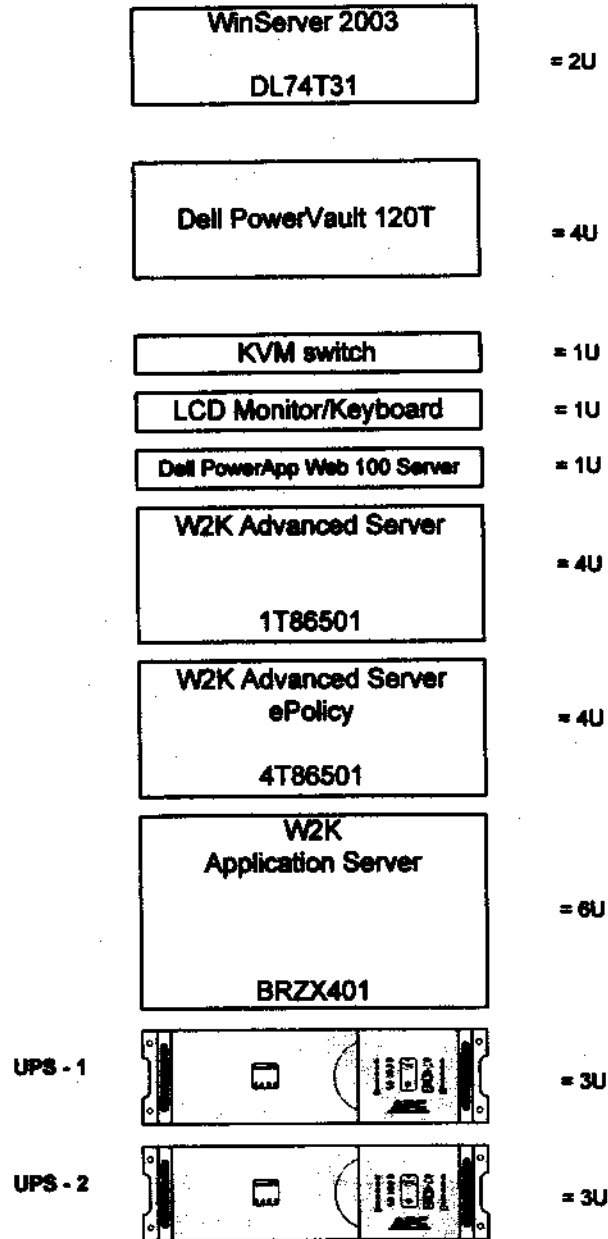

CMS Server Rack

RACK #1 - 42U

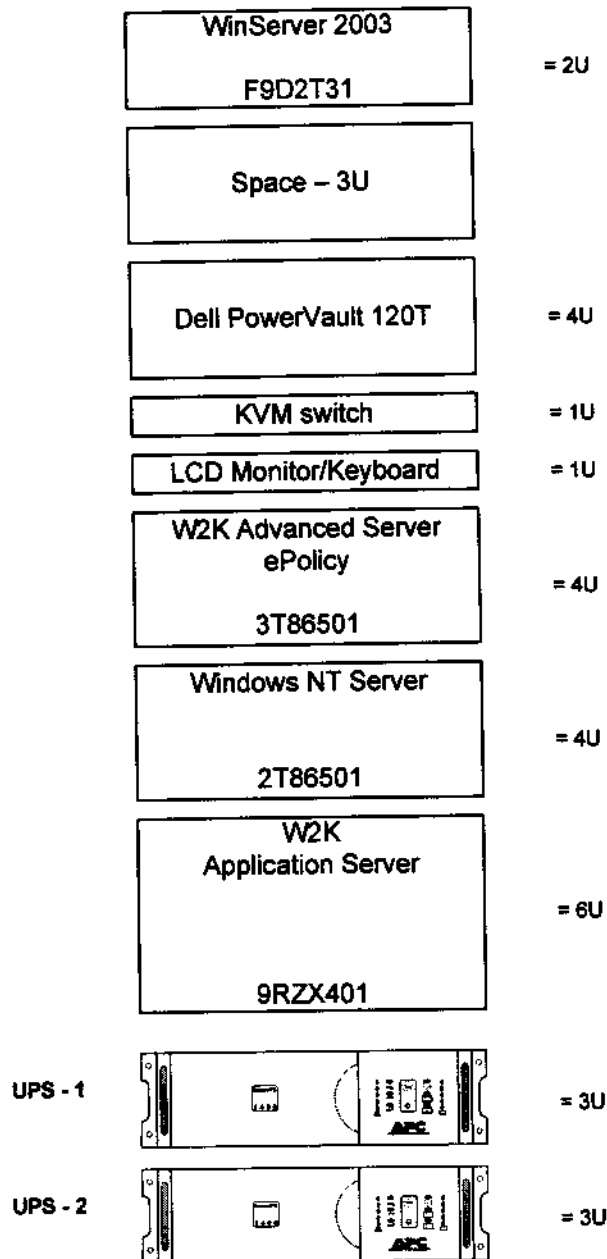

DDE Server Rack

RACK #1 - 42U

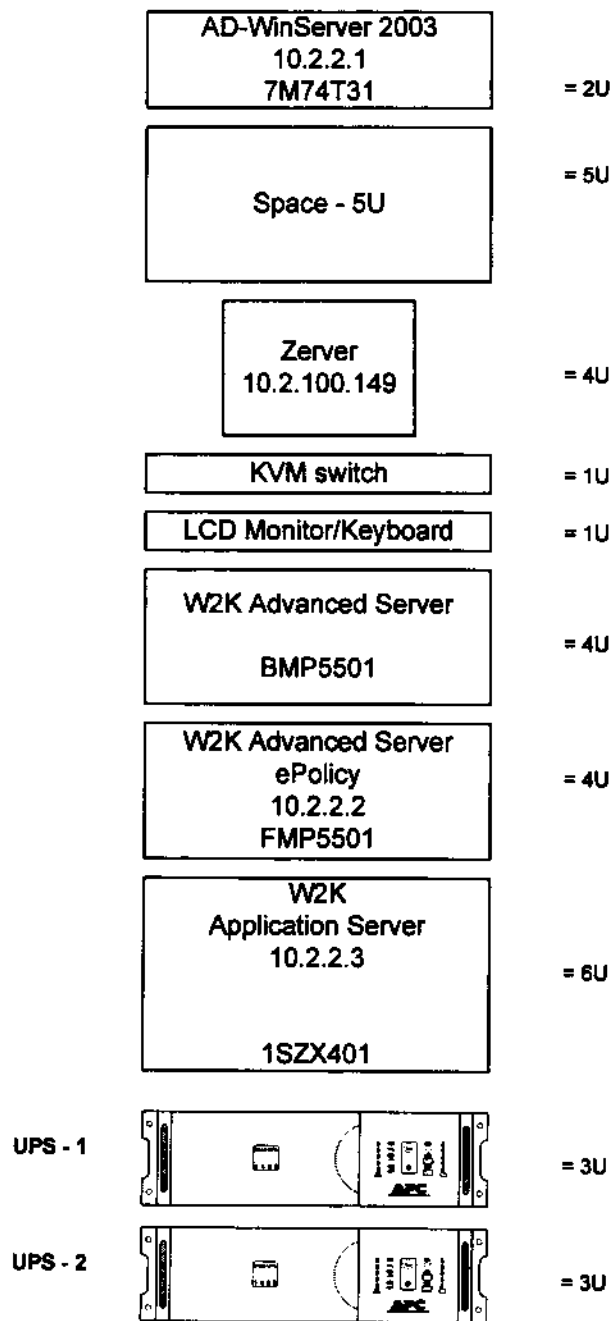

JDE Server Rack

RACK #1 - 42U

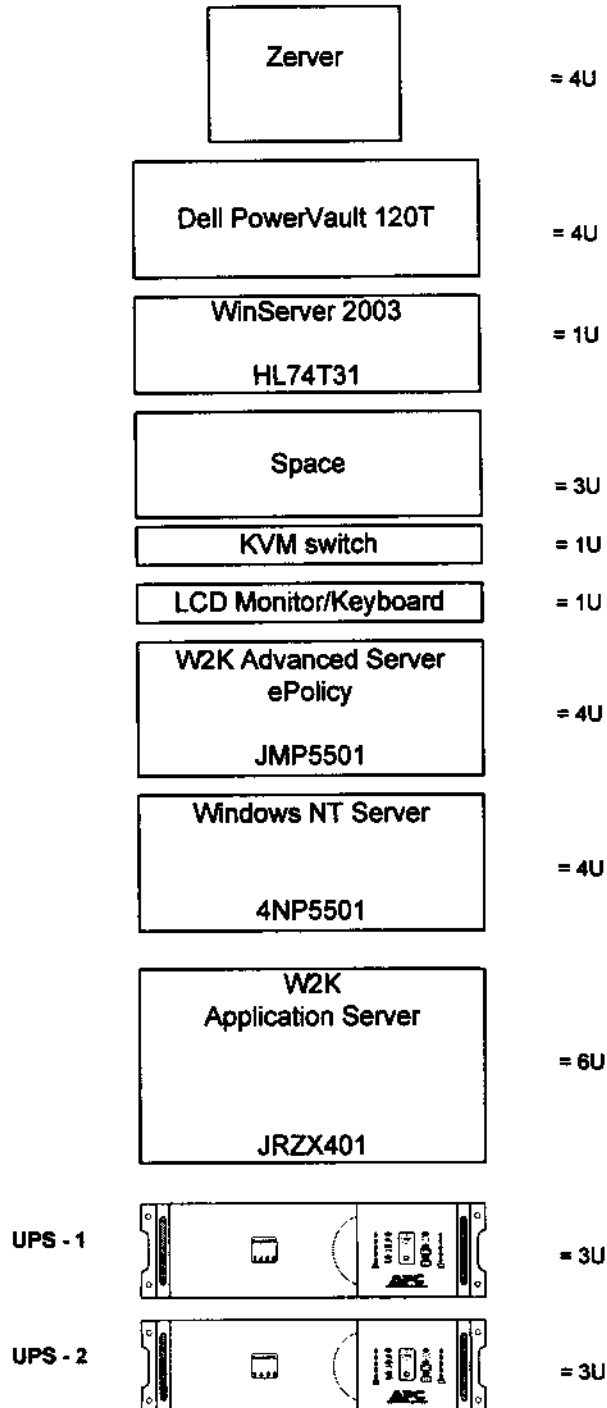

CES Server Rack

RACK #1 - 42U

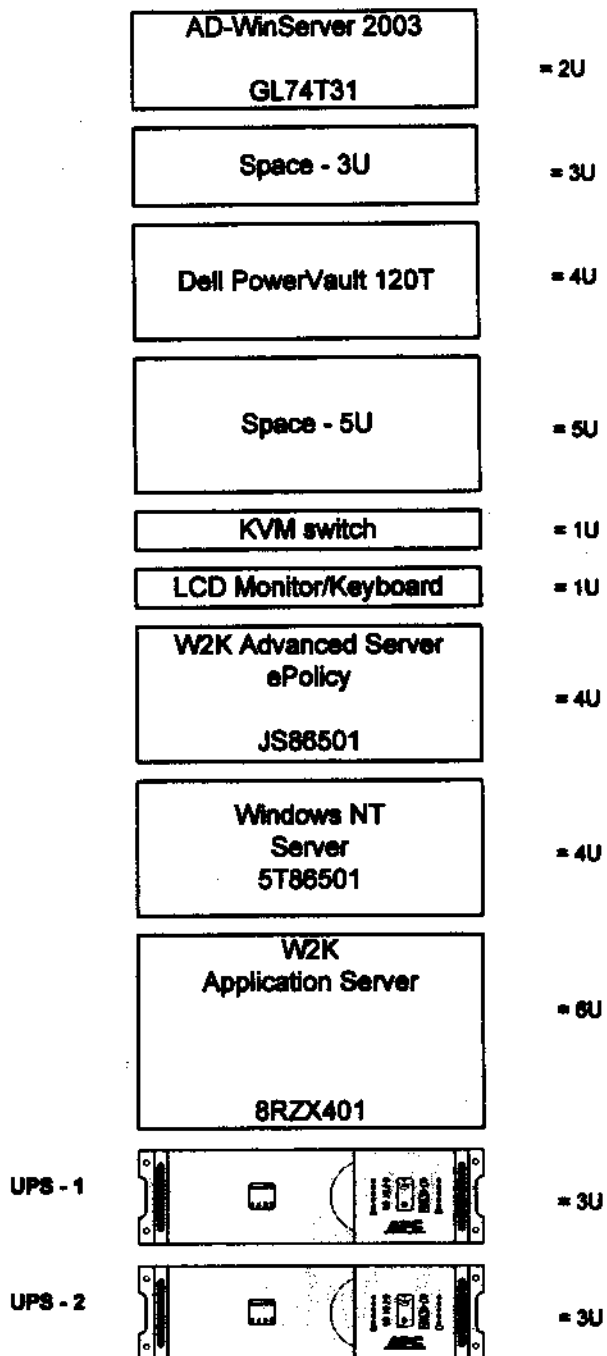

BCE Server Rack

RACK #1 - 42U

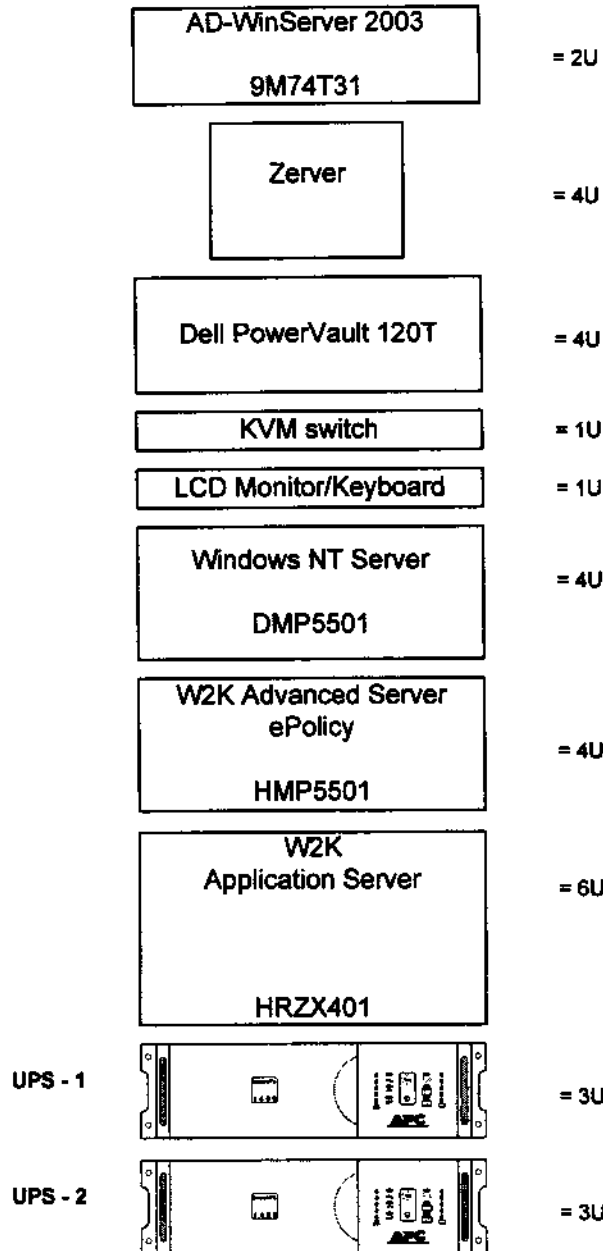

DDE Server Rack

RACK #1 - 42U

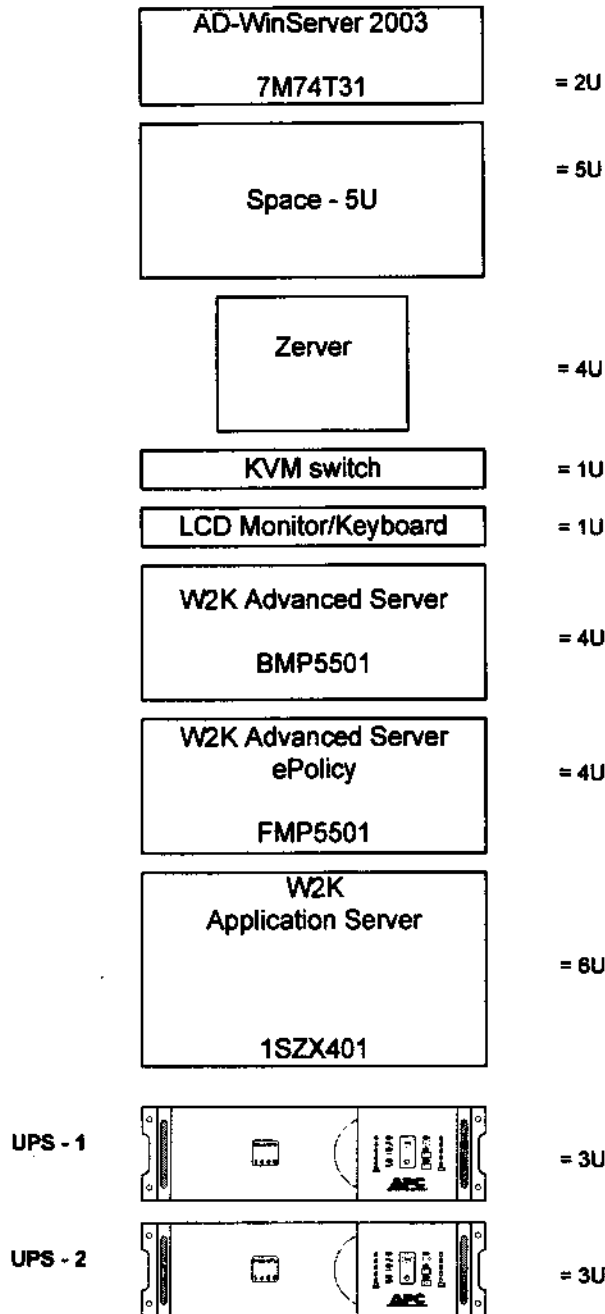

**CANUTILLO INDEPENDENT SCHOOL DISTRICT
OFFICE OF THE SUPERINTENDENT
POST OFFICE BOX 100
CANUTILLO, TEXAS**

Agenda Item: _____ Date: December 14, 2004

Subject: Request permission for use of space in the CISD maintenance facility

Presented By: Charles Hart Consent Agenda: _____

ACTION

1. BACKGROUND INFORMATION:

The West Texas Health Connection has requested use of space at the maintenance facility on Cap Carter. This will be the second year that this request has been made.

2. SUPERINTENDENT RECOMMENDATION:

Recommend approval of the request.

3. BOARD ACTION REQUESTED:

Motion to approve the request for use of space by the West Texas Health Connection as recommended by the Superintendent.

MOTION _____ SECOND _____

AYES _____ NAYS _____



WEST TEXAS HEALTH CONNECTION

Mailing Address: 10249 Bayo Avenue, El Paso, Texas 79925
(915) 598-1371 Fax (915) 595-3271

FAX TRANSMITTAL

TO: Patsy Mendoza
Canutillo Independent School District
877.7414

FROM: Julie Foret
West Texas Health Connection

DATE: 11.30.04

The West Texas Health Connection hereby requests to have the following item placed on the agenda for the December 14, 2004 Board of Trustees meeting:

Request permission for use of space in the C.I.S.D. maintenance facility located at 7710 Cap Carter.

I shall be delivering complete information, with copies for each Trustee, for inclusion with your board agenda package.

Please let me know if you need anything further in order for this item to be place on the agenda.

I can be contacted at: Office 533.9883
Cell 433.2866

Thank you.

**CANUTILLO INDEPENDENT SCHOOL DISTRICT
OFFICE OF THE SUPERINTENDENT
POST OFFICE BOX 100
CANUTILLO, TEXAS**

Date: December 14, 2004

Subject: Request for easement for a portion of Tract 8A, Block 11, Upper Valley Grant, El Paso, Texas by El Paso Electric Company

Presented By: Yusuf Farran Consent Agenda: ✓

ACTION

1. BACKGROUND INFORMATION:

This easement has been requested by the El Paso Electric Company and Mr. Farran concurs.

2. SUPERINTENDENT RECOMMENDATION:

Recommend approval of the request for the easement.

3. BOARD ACTION REQUESTED:

Motion to approve the request for easement for a portion of Tract 8A, Block 11, Upper Valley Grant, El Paso, Texas as recommended by the Superintendent.

MOTION _____ SECOND _____

AYES _____ NAYS _____

EASEMENT

Location Index 3900-3204
School District 081
Work Order No. 04-7-1-00128
Joint Use No. N/A

STATE OF TEXAS
COUNTY OF EL PASO

For one dollar (\$1.00) and other good and valuable consideration, the receipt and sufficiency of which are hereby acknowledged, Canutillo Independent School District, hereinafter called Grantor, grants unto El Paso Electric Company, hereinafter called Grantee, its successors and assigns, whose address is P.O. Box 982, El Paso, Texas 79960, the perpetual, exclusive right, privilege, authority and easement to enter and erect, construct, operate, remove, inspect, access, and maintain a line of poles at any time with any and all necessary towers, cables, lines, wires, crossarms, guys, and anchors for an above ground electric distribution and/or transmission system with any other usual appurtenances, pertaining thereto, together with the overhang of service wires, with the right of access, ingress, and egress thereto for the installation, construction, operation, inspection, repair, maintenance, replacement, renewal or removal thereof, for the distribution and/or transmission of electricity, for any and all purposes, including communications, for which same is or may hereafter be used, over, upon and along the following described premises and the adjoining roads, streets and highways, in the county named above, to wit:

A portion of Tract 8A, Block 11, Upper Valley Grant, El Paso County, Texas as shown on the attached print and made apart hereof

with the right to trim any trees and flora along and around said lines so as to keep the wires cleared, the right to erect and set the necessary brace poles, anchors and guy wires, and to do anything proper and necessary to operate and maintain same.

The authority granted herein includes the right to permit the attachment of the cables of any other company.

Buildings and structures of a permanent nature except fences, boundary walls, walkways and landscaping will not be built on or over the easement, or under any overhead electric lines, except with the prior written consent of the Grantee.

Executed as of the ____ day of _____, 200__.

GRANTOR

Canutillo Independent School District

By: _____
Name: _____
Title: _____

GRANTEE

EL PASO ELECTRIC COMPANY

By: _____
Name: _____
Title: _____

THE STATE OF _____ §
COUNTY OF _____ §

This instrument was acknowledged before me on this ____ day of _____, 200__ by _____ of _____ who stated that (s)he executed same for the purpose and consideration therein, expressed and in the capacity therein stated.

Notary Public in and for
the State of _____

Commission Expires: _____

Overhead Easement

THE STATE OF _____ §
COUNTY OF _____ §

This instrument was acknowledged before me on this _____ day of _____, 200__ by _____ of El Paso Electric Company who stated that (s)he executed same for the purpose and consideration therein, expressed and in the capacity therein stated.

Notary Public in and for
the State of _____

Commission Expires:



TRACT 9

STRAHAN ROAD

PSB
LIFT STATION

15'

15'

TRACT 6

1
6200

6201

6203

6205

5

6207

6209

6211

VIALE LUNGO AVE.

ARTCRAFT ROAD

LEGEND

----- PROPOSED E.P.E. CO. 10 FT. UTIL. ESMT.

GRANTORS INITIALS -----

113

Return to:
El Paso Electric Co.
P.O. Box 982-Loc 501
El Paso, TX. 79960

PROPOSED EASEMENT IN A PORTION OF
TRACT 8A, BLOCK 11
UPPER VALLEY GRANT
EL PASO COUNTY, TEXAS

EL PASO ELECTRIC CO. R.O.W.

DATE 10-25-04

EST. NO.

SCALE NONE

04-7-1-00128

**Canutillo Independent School District
Office of the Superintendent
Post Office Box 100
Canutillo, Texas**

Agenda Item:

Date: December 14, 2004

Subject: Approval of Board Budget Priorities for Fiscal Year 2005-2006

Presented By: Tony Reza

Consent Agenda: X

ACTION

1. BACKGROUND INFORMATION:

The administration is presenting for the board's approval, the budget priorities for fiscal year 2005-2006. This listing was submitted and discussed during the December's Facilities and Finance Committee Meeting. These priorities are in line with the five year plan presented to the board on November 30, 2004. The majority of the priorities are for personnel and supplies needed for the opening of the new high school and the 5th and 6th Grade School. The remaining priorities are items specifically requested or approved by the board in prior board meetings (i.e. maintenance allotment).

2. SUPERINTENDENT RECOMMENDATION:

Recommend approval of the board budget priorities for fiscal year 2005-2006.

3. BOARD ACTION REQUESTED:

The administration requests a motion to accept the board budget priorities for fiscal year 2005-2006 as presented.

MOTION _____

SECOND _____

FOR _____

AGAINST _____

Canutillo Independent School District
Proposed District-wide Board Budget Priorities for Fiscal Year 2005-2006
Priorities Ranked in Order of Need
Subject to Available Funding

Priority	Estimated Cost
1) Step increase for teachers, librarians, and nurses	\$235,000
2) Increase in health care costs*	478,000
3) Additional Staff for New High School	83,760
4) Additional Staff for 5 th & 6 th Grade School	73,760
5) Start up supplies for 5 th & 6 th Grade School	52,320
6) Utilities for New High School	115,514
7) Trash compactor service for New High School	13,000
8) Technology equipment for CHS	25,000
9) Two utility carts for new high school (\$7,000 each)	14,000
10) Supplies for security personnel at the New High School	2,000
11) Yearly payment for artificial turf (if approved by board)	\$88,000
12) Painting and renovation of CHS and CMS	20,000
13) Technology computer lease	250,000
14) Maintenance allotment	100,000
15) Additional busses and gasoline for the Transportation Dept.	118,000
16) Security cameras for district	15,000
17) Music instruments	20,000
18) Overtime for Support Services	4,000
19) Costs associated with moving portables	15,000
20) Hiring outside contractor for moving purposes	10,000
Total Amount of Priorities	\$1,732,354

*Subject to change but currently estimated at a 15 percent increase.

**Canutillo Independent School District
Office of the Superintendent
Post Office Box 100
Canutillo, Texas**

Agenda Item:

Date: December 14, 2004

Subject: Presentation and recommendation to proceed with the issuance of Tax Maintenance Notes for the installation of artificial turf and possibly other capital improvements at the new high school

Presented By: Tony Reza

Consent Agenda: _____

ACTION

1. BACKGROUND INFORMATION:

The district's financial advisors *First Southwest* will present a financing option for the installation of artificial turf and possibly other capital improvements at the new high school. That option would be the issuance of tax maintenance notes. Attached is a comparison between of the proposal from *Riverbend Capital* (which is a lease) and the issuance of tax maintenance notes by the district. That comparison illustrates that based on a financed amount of \$585,000 (which does not include attorney's costs) the district is better suited to issue tax maintenance notes. This attachment provides the board with a financial basis for the debt service payments for the next eight years. Be advised that the amount actually financed will be determined later. The administration will provide more detailed information on the artificial turf and the other capital improvements in the Friday packet or at the board meeting.

2. SUPERINTENDENT RECOMMENDATION:

Recommend approval to proceed with the issuance of tax maintenance notes.

3. BOARD ACTION REQUESTED:

The administration requests a motion to proceed with the issuance of tax maintenance notes.

MOTION _____

SECOND _____

FOR _____

AGAINST _____



Canutillo Independent School District



117

Utilizing Maintenance Tax Notes

December 8, 2004



FIRST SOUTHWEST COMPANY

Page 1





Canutillo Independent School District



Goals & Description of Maintenance Tax Notes



FIRST SOUTHWEST COMPANY

Capital Plan Goals for MTN

★ Goals:

- Utilize most efficient mechanism to fund capital for turf for new high school
- Analyze Riverbend financing proposal (lease) vs. Maintenance Tax Notes (“MTNs”)
- If District decides to utilize MTNs, the District would use MTNs to finance eligible maintenance or remodeling projects and there-by “free up” previously budgeted money for turf.
- District will use M&O funds to repay debt



Description

★ **Authority:**

In 1999, H.B. 4 expanded the definition of allowable financing projects and extended the maximum term to 20 years. Districts now have the ability to issue MTNs for other purposes than environmental cleanup:

- Legally, the purposes for which notes can be issued: maintenance, repair, rehabilitation, or replacement of heating, air conditioning, water, sanitation, roofing, electric, or other building systems of existing school properties

★ **Issuance Process:**

- MTN can be issued without an election.

★ **Debt Capacity:**

- The District is limited to \$1.50 M&O tax rate which is used to repay the Maintenance Tax Notes.

Description

★ MTN repayment:

- MTN are secured by a lien on and pledge of any available funds, including a maintenance tax;
- This means that any State revenues, local M&O taxes or federal monies will be “pledged” or promised to repay the Maintenance Tax Notes.

★ Tax and State Aid Treatment:

- Notes are to be treated as “debt” for tax rollback calculation purposes. The annual rollback calculation and truth-in-taxation notices treat the maintenance taxes levied to pay the notes as “debt.”
- Districts will continue to get Tier II funding for maintenance tax efforts, including maintenance taxes levied to pay Notes.

Financing Matrix

Riverbend vs. Maint. Tax Notes

	Riverbend Capital	Main. Tax Notes
Amount Financed	585000 ⁽¹⁾	615000 ⁽²⁾
Financing Vehicle	Lease Purchase	Main. Tax Notes
Projected Interest Rate	5.25%	3.40%
All Inclusive Cost	???? ⁽¹⁾	4.27% ⁽²⁾
Term	8 years	8 years
Debt Service Payments		
	92,776	88,069
	92,776	88,870
	92,776	91,490
	92,776	88,940
	92,776	91,390
	92,776	88,670
	92,776	90,950
	92,776	93,060
Total Debt Service	742,208	721,439

(1) Riverbend proposal does not include additional costs of attorney's fees & attorney general fees.

(2) Interest rate takes into account \$25,000 for cost of issuance

Next Steps.....

- **CISD Board indicates interest in moving forward with financing through issuance of MTNs**
- **FSC and CISD administration prepare for bond sale**
- **FSC would recommend a private placement of the bonds with Bank of America**
 - A private placement would eliminate a lot of the costs associate with a regular bond deal. Ratings fees, paying agent fees, OS fees, would be eliminated.
- **FSC would be prepared to come to the Board with the bond sale as early as Dec. 14th if authorization received tonight (December 8th)**
- **If approved on Dec. 14th, then closing would occur on Jan. 11th, at which time the District would receive the bond proceeds.**



CANUTILLO INDEPENDENT SCHOOL DISTRICT
OFFICE OF THE SUPERINTENDENT
POST OFFICE BOX 100
CANUTILLO, TEXAS

Agenda Item:

Date: December 14, 2004

Subject: Approval for Optometric Services

Presented By: Tony Reza

Consent Agenda: X

ACTION

1. BACKGROUND INFORMATION:

As stated in the Education Code Section 44.031, Item F, a school district may purchase an item or services that is available through professional services contract. In addition, as stated in Board Policy CH(Local), purchases over \$10,000 require Board Approval. Dr. Cris Koplos, optometrist, will provide vision screenings for 800 students to include kindergarten and fifth grade district wide. This initiative which includes collaboration with Texas Tech University Health Science Center and El Paso Community College will yield research findings that will bring into focus the relationship between vision related problems and learning deficits. Request approval to award contract to Dr. Cris Koplos for no more than \$25,000 which will be provided through Title I funds.

2. SUPERINTENDENT RECOMMENDATION:

Recommend approval to contract Dr. Cris Koplos for vision screening services.

3. BOARD ACTION REQUESTED:

The Board of Trustees approves the Superintendent's recommendation.

MOTION _____ SECOND _____

AYES _____ NAYS _____



East Side

Eastwood Middle School students will wear pedometers to measure their steps for a week

Coming Thursday

[Disadvantaged students get free optical exams]

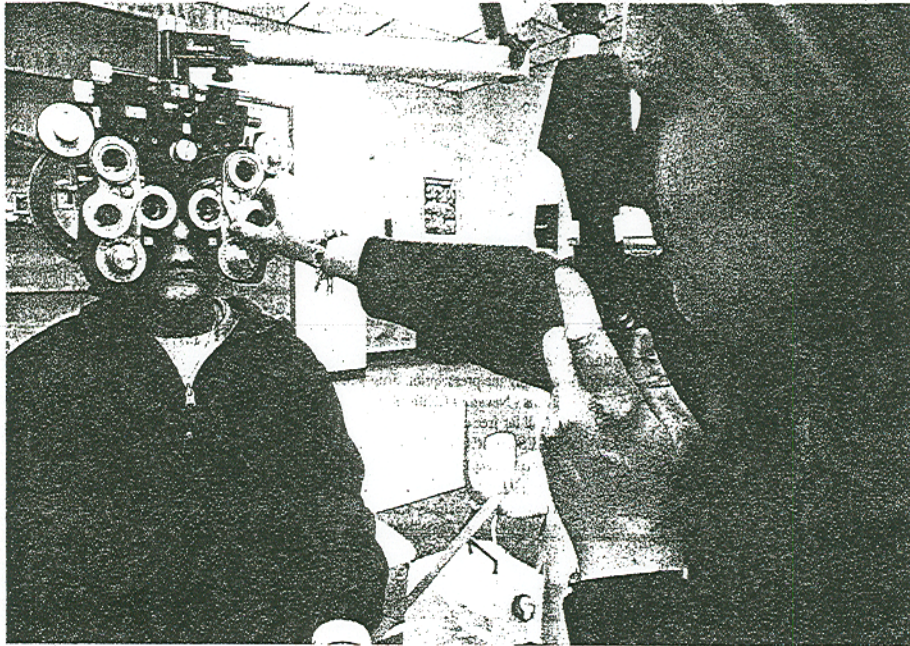

Mark Lambie / El Paso Times

Dalia Juárez, 10, had her eyes examined on Wednesday by Dr. Chris Koplos at Davenport Elementary in the Canutillo school district. About 800 students will have their vision screened through a new program.

SCHOOLS KEEP EYE ON VISION

Initiative will focus on links to learning difficulties

By Michael D. Hernandez
El Paso Times

In a hushed and darkened classroom Wednesday, Davenport Elementary School fifth-grader Ashley Rubio stared through a succession of lenses and struggled to make out a blurry collection of figures floating upon a screen less than 20 feet away.

"D-F-G ... 7," Ashley, 10, said with little confidence before moving on to the next perplexing row of letters and numerals.

Within 20 minutes, Ashley's screening had revealed she suffered from amblyopia — a loss of sharpness in her vision that could affect the pace at which she learns and one of many eye disorders that educators from the Canutillo Independent School District are hoping to identify during an ambitious program launched last week.

Because vision plays a vital role in the classroom, the district is performing optometric vision screenings for about 800 students in kindergarten and fifth-grade, an effort that has become an essential initiative for a community grappling with being largely economically disadvantaged and medically underserved, educators and optometry experts said.

"Many of our families do not have health insurance or the money for basic medical needs,

Symptoms that indicate there may be vision-related problem for a school-aged child occur when a student:

- ▶ Loses his or her place while reading.
- ▶ Avoids close work.
- ▶ Holds reading material closer than normal.
- ▶ Tends to rub his or her eyes.
- ▶ Has headaches.
- ▶ Turns or tilts head

Closerlook

to use one eye only.

- ▶ Makes frequent reversals when reading or writing.
- ▶ Uses finger to maintain place when reading.
- ▶ Omits or confuses small words when reading.
- ▶ Consistently performs below potential.

Source: American Optometric Association.

so many of these things ultimately become the schools' responsibility to help our students," Rachel Aguilar, the district's occupational therapist, said. "When some of them have problems keeping up with these new (scholastic) standards, we have found that vision is often related."

The vision screenings are funded by federal money and also will yield research that will help bring into focus the relationship between vision-related problems and learning deficits.

Before Davenport fifth-grader Dalia Juárez began the school

year with a pair of eyeglasses to correct astigmatism, her classroom experiences were less than stellar.

"Sometimes the board was blurry to me and my eyes would get tired and give me headaches," she said after her screening Wednesday. "My glasses help a lot."

One priority of the screenings is an agreement that allows the district to buy eyeglasses for \$20 per student from the El Paso Community College. The glasses will stay at the students' campuses. Parents can also buy a \$20 pair of glasses for the children to use

outside of school, Aguilar said.

Dr. Chris Koplos, who is conducting the vision screenings for the district, said such a thorough initiative — one that district officials hope to make available to every student — is a rare step to help stem a growing problem.

"This is the first time I've heard of a school district taking on this initiative and I think Canutillo should be commended," she said, adding that research for the field has helped uncover why some children are turned off by reading.

Dr. Derek Cunningham, a clinical faculty instructor at Texas Tech University Health Sciences Center who will study the initiative's research, said that some studies indicate a rudimentary eye examination conducted by schools fail to catch upwards of 30 percent of vision-related problems.

He hopes the thorough screenings initiated by Canutillo will help spark interest throughout the educational community.

"We became involved because we simply want to help improve a child's quality of life," he said. "If we can show how important vision is related to the ability to learn, then perhaps the state of Texas can take a closer look at this issue."

**CANUTILLO INDEPENDENT SCHOOL DISTRICT
OFFICE OF THE SUPERINTENDENT
POST OFFICE BOX 100
CANUTILLO, TEXAS**

Agenda Item: _____ Date: December 14, 2004

Subject: Adoption of CW (Local) - New Facilities as recommended by Policy Committee - second reading

Presented By: Pam Padilla Consent Agenda: ✓

ACTION

1. BACKGROUND INFORMATION:

This local policy pertaining to the naming of new facilities was presented to the Policy Committee on October 26. It was then presented to the Board for first reading on November 9th. The committee made several suggestions and they have been implemented into the policy. Dr. Padilla has revised the policy for your final review and adoption.

2. SUPERINTENDENT RECOMMENDATION:

Recommend adoption of policy CW (Local) for second reading.

3. BOARD ACTION REQUESTED:

Motion to adopt Board Policy CW (Local) - New Facilities for second reading as recommended by the Superintendent.

MOTION _____ SECOND _____

AYES _____ NAYS _____

NEW FACILITIES – Proposed Policy for discussion

CW
(LOCAL)

NAMING
FACILITIES

The Board may name or rename a District facility, or portion of a building, such as the library or auditorium:

1. To reflect the name of the residential community or communities that the facility serves,
2. After a local geographic area or feature or after local municipalities, or
3. To honor an outstanding individual.

NAMING OF A
NEW SCHOOL

For each new school built in the District, the Board President shall establish a school name task force, of not more than twelve persons, for the purpose of collecting nominations for naming the school and presenting a recommendation to the Board.

The task force shall request nominations from the community. Geographical, historical, and traditional names shall be considered. Names directly related to the District shall receive first consideration. Nominations shall include the following, if the suggested name is a person:

1. Biographical data,
2. Significant contributions made by the individual, and
3. A statement of why the school should be named after that person.

The task force shall hold at least two public meetings at which members of the community may participate in the process. The task force shall present its recommendation to the Board. A simple majority vote shall be required to approve the name.

Each new school shall be named in a timely fashion.

Once a school is named and a principal assigned, the principal shall establish a committee to recommend a school mascot and colors. This committee will submit its recommendation to the Superintendent for final approval.

NAMES ON
BUILDING
PLAQUES

Dedication plaques shall include the following information:

1. The name of the school or building.
2. The year completed.
3. Those individuals on the Board, with titles of officers, and the

Superintendent on the date when the architectural design is approved by the Board.

4. Those individuals on the Board, with titles of officers and years of service for the members who subsequently retire, and the Superintendent on the date when project is completed.
5. The name of the architectural firm which may include the city and state in which the firm is located.
6. The name of the contractor which may include the city and state where the contractor's business is located.

Any information other than the above must have approval of the Board to be included on a dedication plaque.

RENAMING The renaming of any school or educational facility may occur only if its educational function or support activity is changed and/or redirected; or if the community served by the facility demonstrates a major consensus for a name change. A unanimous vote of the Board shall be required to approve any action to re-name a school. Regardless of physical location, the name of Canutillo Elementary, Canutillo Middle, and Canutillo High School may not be changed.

DATE ISSUED:
LDU-04-02
CW(LOCAL)-X

**CANUTILLO INDEPENDENT SCHOOL DISTRICT
OFFICE OF THE SUPERINTENDENT
POST OFFICE BOX 100
CANUTILLO, TEXAS**

Agenda Item: _____ Date: December 14, 2004

Subject: Adoption of TASB Localized Policy Manual Update 73 as recommended by Policy Committee (including Policies GKD (Local) and GKDA (Local)) - second reading

Presented By: Renee O'Donnell Consent Agenda: ✓

ACTION

1. BACKGROUND INFORMATION:

Update 73 was presented in its entirety with the **exceptions** of policies GKD (Local) and GKDA (Local) at the Policy Committee Meeting on October 26th. These policies were not ready for review in time for the Policy Committee meeting.

Policies GKD (Local) and GKDA (Local) are included in this exhibit for your review. These policies have gone through review by campus principals and district directors with few changes to the present, existing GKD policy. Rather than call a special policy committee meeting to review these policies, and with Mr. Hecker's approval, they have been included with TASB Update 73 for first reading. The entire update will be presented again to the Board at the December meeting for adoption.

Several corrections were made to DEA (Local) in order to comply with the Fair Labor Standards Act. These changes have been incorporated and a draft copy is also included in this exhibit for your perusal.

2. SUPERINTENDENT RECOMMENDATION:

Recommend adoption of TASB Localized Policy Manual Update 73 for second reading.

3. BOARD ACTION REQUESTED:

Motion to adopt TASB Localized Policy Manual Update 73 for second reading as recommended by the Superintendent.

MOTION _____ SECOND _____

AYES _____ NAYS _____

COMPENSATION AND BENEFITS:
SALARIES, WAGES, AND STIPENDS

DEA
(LOCAL)

	<p>The Superintendent shall recommend to the Board for approval pay structures and compensation plans for all District employees. Pay structures shall be designed and administered for the purpose of attracting and retaining qualified employees to achieve District goals. The Superintendent shall administer and maintain pay systems in accordance with administrative procedures for the District compensation plan.</p>
PAY SYSTEMS DESCRIPTION	<p>The Superintendent shall assign positions to pay ranges that define the minimum and maximum base pay for the positions.</p> <p>All employees shall be paid within the assigned pay ranges unless exceptions are granted by the Board.</p> <p>The system shall be designed and administered to accomplish the following:</p> <ol style="list-style-type: none">1. Stay competitive with appropriate labor markets for the various categories of personnel.2. Recognize the levels of skill, effort, and responsibility required of different jobs.3. Be fiscally controlled and cost effective. <p>A copy of the District's pay system shall be available in the administrative offices.</p>
PAY RANGES	<p>Pay ranges for each pay grade shall establish minimum and maximum rates of pay within the range. All pay ranges shall be established by monthly, daily, or hourly base rates to promote consistent treatment of employees who have different work periods. Employees shall be paid within the range of rates established for the position assigned.</p> <p>The Superintendent shall review pay ranges on an annual basis and recommend adjustments consistent with economic and job market indicators.</p>
PAY ADVANCEMENT	<p>Pay ranges shall be structured to allow the opportunity to increase employee pay within the range for continued service to the District. The Superintendent shall make recommendations regarding employee increases on an annual basis. Recommendations shall be based on consideration of such factors as cost of living indexes, wage increases within competitive job markets, and budget resources. No employee with less than a satisfactory performance evaluation will receive a pay increase.</p>
PAY BUDGET INCREASE	<p>The Superintendent shall recommend to the Board an amount for employee pay increases as part of the annual budget. Pay</p>

COMPENSATION AND BENEFITS:
SALARIES, WAGES, AND STIPENDS

DEA
(LOCAL)

increases beyond the budgeted amount for individuals or positions shall be subject to Board approval.

PAY ADMINISTRATION

Employee pay adjustments shall be administered by the Superintendent or designee in accordance with written procedures to promote impartial and consistent treatment of all employees. Administrative procedures shall include hiring guidelines, promotion guidelines, updating pay ranges, method for calculating and applying a general pay increase, and a process for job classification review.

CLASSIFICATION OF
POSITIONS

Each job in the District shall be assigned to a pay grade based on the level of skill, effort, and responsibility required for the job assignment. The Superintendent shall classify new positions or reclassify existing positions as necessary based on job requirements and comparability to other positions in the District.

The Superintendent or designee shall determine the classification of positions or employees as "exempt" or "nonexempt" for purposes of payment of overtime in compliance with the Fair Labor Standards Act.

EXEMPT

The District shall pay employees who are exempt from the overtime pay requirements of the Fair Labor Standards Act (FLSA) on a salary basis. The salaries of these employees are intended to cover all hours worked, and the District shall not make deductions that are prohibited under the FLSA.

An employee who believes deductions have been made from his or her salary in violation of this policy should bring the matter to the District's attention, through the District's complaint policy [see DGBA]. If improper deductions are confirmed, the District will reimburse the employee and take steps to ensure future compliance with the FLSA.

NONEXEMPT

Nonexempt employees may be compensated on an hourly basis or on a salary basis. Employees who are paid on an hourly basis shall be compensated for all hours worked. Employees who are paid on a salary basis are paid for a 40-hour workweek and do not earn additional pay unless the employee works more than 40 hours.

A nonexempt employee shall have the approval of his or her supervisor before working overtime. An employee who works overtime without prior approval is subject to discipline, up to and including termination, but shall be compensated in accordance with the Fair Labor Standards Act.

COMPENSATORY
TIME

Compensation for overtime hours shall be awarded at one and a half times the employee's regular rate of pay or by time and a half earned in compensatory time. The employee shall be informed in

COMPENSATION AND BENEFITS:
SALARIES, WAGES, AND STIPENDS

DEA
(LOCAL)

advance if overtime hours will accrue compensatory time rather than pay. Compensatory time earned by nonexempt employees may not accumulate beyond a maximum of 120 hours. If an employee has a balance of more than 120 hours of overtime, the employee will be required to take compensatory time or, at the District's option, will receive overtime pay.

Unless the District receives prior written notification, all absences shall be charged against compensatory time before being charged against sick leave or personal leave.

Compensatory time shall be used by December of the duty year (July-June) in which it is earned. In January of the duty year, the District shall pay an employee overtime for all unused compensatory time remaining at the end of December of the previous duty year. Use of compensatory time may be at the employee's request or as determined by the employee's supervisor to protect the District's schedules and activities.

WORKWEEK
DEFINED

For purposes of FLSA compliance, the workweek for District employees shall be 12:00 a.m. Wednesday until 11:59 p.m. Tuesday.

SUPPLEMENTAL
DUTIES

The Superintendent or designee may assign noncontractual supplemental duties to personnel exempt under the Fair Labor Standards Act, as needed. The employee shall be compensated for these assignments according to the supplemental duty pay schedule established by the Board. These assignments may be discontinued at any time for any reason or no reason, by either party. The assignment of these duties shall not create any expectation of continued assignment to that same duty or any other duty.

Under the Fair Labor Standards Act (FLSA), extra duty pay assignments for noncontractual (nonexempt) employees may be assigned if the duties are occasional and sporadic and are not related to the employee's regular duties. Therefore, the District shall assign a nonexempt employee as a sponsor for a nonacademic/UII activity only if an exempt employee is unavailable for the assignment. The Extra Duty Stipend/Supplemental Pay Increment Schedule published by the District contains additional information.

ADVANCED DEGREE

When a professional employee completes a master's or doctorate degree in his or her teaching field or area of work responsibility prior to September 1, a pay increase based on the degree shall begin at that time; for degrees completed in December, a prorated pay increase for the employee shall begin in January.

COMPENSATION AND BENEFITS:
SALARIES, WAGES, AND STIPENDS

DEA
(LOCAL)

CREDITABLE
SERVICE

Employees who are receiving workers' compensation wage benefits and who have no available paid leave shall not earn creditable years of service while absent from duty.

In order to accrue a creditable year of service, an employee must be employed for at least 90 full-time days or the equivalent.

COMMUNITY RELATIONS:
NONSCHOOL USE OF SCHOOL FACILITIES

GKD
(LOCAL)

SCOPE OF USE	<p>The District shall permit nonschool use of designated District facilities for educational, recreational, civic, or social activities when these activities do not conflict with school use or with this policy.</p> <p>Approval shall not be granted for any purpose that would damage school property or to any group that has damaged District property.</p> <p>Note: See the following policies for other information regarding facilities use:</p> <ul style="list-style-type: none">• Use by employee professional organizations: DGA• Use of facilities for school-sponsored and school-related activities: FM• Use by noncurriculum-related student groups: FNAB• Use by District-affiliated school-support organizations: GE
NONPROFIT FUND-RAISING	<p>The District shall permit nonprofit organizations to conduct fund-raising events on District property when these activities do not conflict with school use or with this policy.</p>
FOR-PROFIT USE	<p>The District shall not permit individuals or for-profit organizations to use its facilities for financial gain; however, the District shall permit public performances, recitals, or presentations so long as no admission fee is charged and when these activities do not conflict with school use or with this policy.</p>
SCHEDULING	<p>Requests for nonschool use of District facilities shall be considered on a first-come-first-served basis.</p> <p>Academic and extracurricular activities sponsored by the District shall always have priority when any use is scheduled. [See FM] The Superintendent or designee shall have authority to cancel a scheduled nonschool use if an unexpected conflict arises with a District activity.</p>
APPROVAL OF USE	<p>The principal is authorized to approve use of facilities on a school campus. The Superintendent or designee is authorized to approve use of all other District facilities.</p>
EXCEPTION	<p>No approval shall be required for nonschool-related recreational use of the District's unlocked, outdoor recreational facilities, such as the track, playgrounds, tennis courts, and the like, when the facilities are not in use by the District or for a scheduled nonschool purpose.</p>
EMERGENCY USE	<p>In case of emergencies or disasters, the Superintendent or designee may authorize the use of school facilities by civil defense, health, or emergency service authorities.</p>

COMMUNITY RELATIONS:
NONSCHOOL USE OF SCHOOL FACILITIES

GKD
(LOCAL)

REPEATED USE	The District shall not permit any one organization to monopolize facilities.
USE AGREEMENT	Any organization or individual approved for a nonschool use of District facilities shall be required to complete a written agreement indicating receipt and understanding of this policy and any applicable administrative regulations, and acknowledging that the District is not liable for any personal injury or damages to personal property related to the nonschool use.
FEES FOR USE	<p>Nonschool users shall be charged a fee for the use of designated facilities.</p> <p>The Superintendent or designee shall establish and publish a schedule of fees based on the cost of the physical operation of the facilities, as well as any applicable personnel costs for supervision, custodial services, food services, security, and technology services.</p>
EXCEPTIONS	<p>Fees shall not be charged when school buildings are used for public meetings sponsored by state or local governmental agencies.</p> <p>Fees shall not be charged for use by District employee professional organizations. [See DGA]</p>
REQUIRED CONDUCT	<p>Persons or groups using school facilities shall:</p> <ol style="list-style-type: none">1. Conduct business in an orderly manner.2. Abide by all laws and policies, including but not limited to those prohibiting the use, sale, or possession of alcoholic beverages, illegal drugs, and firearms, and the use of tobacco products on school property. [See GKA]3. Make no alteration, temporary or permanent, to school property without prior written consent from the Superintendent. <p>All groups using school facilities shall be responsible for the cost of repairing any damages incurred during use and shall be required to indemnify the District for the cost of any such repairs.</p>

NONSCHOOL USE OF SCHOOL FACILITIES:
DISTRIBUTION OF NONSCHOOL LITERATURE

GKDA
(LOCAL)

DISTRIBUTION OF
NONSCHOOL
LITERATURE
PERMITTED

Written or printed materials, handbills, photographs, pictures, films, tapes, or other visual or auditory materials over which the District does not exercise control shall not be sold, circulated, or distributed by persons or groups not associated with the school or a school support group on any school premises in the District without permission in accordance with this policy.

[See CPAB regarding use of the District's internal mail system and FNAA regarding distribution of nonschool literature by students]

TIME, PLACE, AND
MANNER
RESTRICTIONS

Except as provided at FNAA(LOCAL), classrooms and hallways shall not be used during the school day for the distribution of any nonschool literature over which the District does not exercise control.

Each campus principal shall designate a location or means by which nonschool literature that is appropriate for distribution, as provided in this policy, may be made available or distributed to students or others at the principal's campus in accordance with the time, place, and manner restrictions developed and approved by the principal.

The Superintendent or designee shall designate appropriate locations and determine time, place, and manner restrictions regarding distribution of nonschool literature at District facilities other than school buildings, in accordance with this policy.

LIMITATIONS ON
CONTENT

Nonschool literature shall not be distributed on District property if:

1. The materials are obscene, vulgar, or otherwise inappropriate for the age and maturity of the audience.
2. The materials endorse actions endangering the health or safety of students.
3. The distribution of such materials would violate the intellectual property rights, privacy rights, or other rights of another person.
4. The materials contain defamatory statements about public figures or others.
5. The materials advocate imminent lawless or disruptive action and are likely to incite or produce such action.
6. The materials are hate literature or similar publications that scurrilously attack ethnic, religious, or racial groups or contain content aimed at creating hostility and violence; and the materials would materially and substantially interfere with school activities or the rights of others.

NONSCHOOL USE OF SCHOOL FACILITIES:
DISTRIBUTION OF NONSCHOOL LITERATURE

GKDA
(LOCAL)

7. There is reasonable cause to believe that distribution of the nonschool literature would result in material and substantial interference with school activities or the rights of others.

PRIOR REVIEW

All nonschool literature intended for distribution to multiple recipients on District premises under this policy shall be submitted to the Superintendent or designee for prior review in accordance with the following:

1. Materials shall include the name of the organization or person sponsoring the distribution.
2. Using the standards found in this policy at LIMITATIONS ON CONTENT, the Superintendent or designee shall approve or reject submitted materials within two school days of the time the materials were received.
3. The requestor may appeal a rejection in accordance with the appropriate District complaint policy, [See DGBA, FNG, or GF]

EXCEPTIONS TO
PRIOR REVIEW

Prior review shall not be required for distribution of nonschool literature in the following circumstances:

1. Distribution of materials by an attendee to other attendees at a school-sponsored meeting intended for adults and held after school hours.
2. Distribution of materials by an attendee to other attendees at a community group meeting held after school hours in accordance with GKD(LOCAL).
3. Distribution for electioneering purposes during the time a school facility is being used as a polling place in accordance with state law. [See BBB]

All nonschool literature distributed under these exceptions shall be removed from District property immediately following the event at which the materials were distributed.

Even when prior review is not required, all other provisions of this policy shall apply.

VIOLATIONS OF
POLICY

Failure to comply with this policy regarding distribution of non-school literature shall result in appropriate administrative action, including but not limited to confiscation of nonconforming materials and/or suspension of use of District facilities. Appropriate law enforcement officials may be called if a person refuses to comply with this policy or fails to leave the premises when asked. [See GKA]

Instruction Sheet

TASB Localized Policy Manual Update 73

District Canutillo ISD

Code	Action To Be Taken	Note
BBB (LEGAL)	Replace policy	Revised policy
BBFA (LEGAL)	Replace policy	Revised policy
BBFA (EXHIBIT)	Replace exhibit	Revised exhibit
BE (LEGAL)	Replace policy	Revised policy
BEC (LEGAL)	Replace policy	Revised policy
BED (LEGAL)	Replace policy	Revised policy
BED (LOCAL)	Replace policy	Revised policy
BJA (LEGAL)	Replace policy	Revised policy
BJCE (LEGAL)	Replace policy	Revised policy
BJCF (LOCAL)	Replace policy	Revised policy
BJCG (LEGAL)	Replace policy	Revised policy
CFEA (LEGAL)	Replace policy	Revised policy
CHF (LEGAL)	Replace policy	Revised policy
CMD (LEGAL)	Replace policy	Revised policy
CNB (LEGAL)	Replace policy	Revised policy
CO (LEGAL)	Replace policy	Revised policy
CPAB (LEGAL)	Replace policy	Revised policy
CRD (LEGAL)	Replace policy	Revised policy
CRF (LEGAL)	Replace policy	Revised policy
CRF (LOCAL)	Replace policy	Revised policy
CVA (LEGAL)	Replace policy	Revised policy
CVE (LEGAL)	Replace policy	Revised policy
DBE (LEGAL)	Replace policy	Revised policy
DC (LEGAL)	Replace policy	Revised policy
DC (EXHIBIT)	No exhibit enclosed	See explanatory note
DCD (LEGAL)	Replace policy	Revised policy
DEA (LEGAL)	Replace policy	Revised policy
DEA (LOCAL)	Replace policy	Revised policy
DEE (LEGAL)	Replace policy	Revised policy
DFBB (LOCAL)	Replace policy	Revised policy
DGA (LOCAL)	Replace policy	Revised policy

Instruction Sheet

TASB Localized Policy Manual Update 73

Code	Action To Be Taken	Note
DGBA (LEGAL)	Replace policy	Revised policy
DGBA (LOCAL)	Replace policy	Revised policy
DGBA (EXHIBIT)	No exhibit enclosed	See explanatory note
DH (LOCAL)	Replace policy	Revised policy
DK (LOCAL)	Replace policy	Revised policy
EFE (LEGAL)	Replace policy	Revised policy
EFE (LOCAL)	Replace policy	Revised policy
EFE (EXHIBIT)	DELETE exhibit	See explanatory note
EHBK (LEGAL)	Replace policy	Revised policy
EIC (LEGAL)	Replace policy	Revised policy
EIF (LEGAL)	Replace policy	Revised policy
EIF (LOCAL)	No policy enclosed	See explanatory note
EIF (EXHIBIT)	Replace exhibit	Revised exhibit
EK (LEGAL)	Replace policy	Revised policy
EK (LOCAL)	No policy enclosed	See explanatory note
FEA (LOCAL)	Replace policy	Revised policy
FFAA (LEGAL)	Replace policy	Revised policy
FFAB (LEGAL)	Replace policy	Revised policy
FFAB (EXHIBIT)	Replace exhibit	Revised exhibit
FFG (EXHIBIT)	Replace exhibit	Revised exhibit
FM (LOCAL)	Replace policy	Revised policy
FNC (LOCAL)	Replace policy	Revised policy
FNCB (LOCAL)	DELETE policy	See explanatory note
FNCF (LOCAL)	DELETE policy	See explanatory note
FNCG (LEGAL)	Replace policy	Revised policy
FNCG (LOCAL)	DELETE policy	See explanatory note
FNG (LEGAL)	Replace policy	Revised policy
FNG (LOCAL)	Replace policy	Revised policy
FNG (EXHIBIT)	No exhibit enclosed	See explanatory note
FO (LEGAL)	Replace policy	Revised policy
FOC (EXHIBIT)	Replace exhibit	Revised exhibit
GBA (EXHIBIT)	Replace exhibit	Revised exhibit
GE (LOCAL)	ADD policy	See explanatory note
GF (LEGAL)	ADD policy	New policy

Instruction Sheet

TASB Localized Policy Manual Update 73

Code		Action To Be Taken	Note
GF	(LOCAL)	Replace policy	Revised policy
GF	(EXHIBIT)	No exhibit enclosed	See explanatory note
GKA	(LEGAL)	Replace policy	Revised policy
GKA	(LOCAL)	Replace policy	Revised policy
GND	(LEGAL)	Replace policy	Revised policy
GRA	(LEGAL)	Replace policy	Revised policy