

Crete City Council Regular Meeting
Tuesday, April 20, 2021 6:00 PM
Crete City Hall Council Chambers
243 E 13th Street
Crete, NE 68333

1. Open Meeting

- In accordance with Nebraska law, a copy of the Open Meetings Act can be found in the back of the Council Chambers.
- Items listed on the agenda may be considered in any order.
- Please stand for the Pledge of Allegiance.

2. Roll Call

- Attendance of members will be recorded to determine the presence of a quorum for official actions.

3. Consent Agenda

- All items listed on the consent agenda will be approved by one motion and vote. No separate discussion of these items will occur unless the Mayor, a Councilmember, or a citizen so requests. If such a request is made, the item will be moved out of the consent agenda and considered separately.

A. Approve Meeting Minutes

1. Legislative and Economic Development Committee - April 6, 2021
2. Public Safety Committee - April 6, 2021
3. Public Works Committee - April 6, 2021
4. City Council Regular Meeting - April 6, 2021

B. Accept the City Treasurer's Report

C. Approve the Payment of Claims Against the City

4. Items of Business

- Action may be taken to discuss/limit discussion, to hear testimony in favor of or in opposition to, and to approve or disapprove any matter presented under this title.

A. Consider adopting Resolution 2021-02: A resolution declaring a vacancy in the elective office of Councilmember for the First Ward.

B. Consider approving the Mayor's appointment of Jerry Wilcox as City Clerk for the term beginning April 21, 2021 and ending December 1, 2022.

C. Public Hearing on PBS Aircraft's application for a special exception permit for a billboard along Highway 103.

D. Consider approving PBS Aircraft's application for a special exception permit for a billboard along Highway 103.

- E. Public Hearing on The 1206 LLC's application for a new Class I Liquor License for 1206 Main Avenue.
 - F. Consider and provide a recommendation to the Liquor Control Commission on The 1206 LLC's application for a liquor license.
 - G. Consider approving Charter Communication's application for a permit to occupy the right-of-way along Juniper Avenue between 12th Street and 14th Street.
 - H. Review the proposals for Keno Operator and consider selecting an operator and entering into a new operator contract.
 - I. Consider enacting Ordinance 2124: An ordinance to issue bonds and make special assessments for the 2021 gap paving projects.
 - J. Consider approving the bid for the Wildwood Pool Splashpad with the recommended cost adjustments from the Park and Recreation Committee.
 - K. Consider approving the subdivision improvements for Fairway Development 1st Addition.
 - L. Consider adopting Resolution 2021-03: A resolution proposing the annexation of West Crete Addition.
 - M. Consider authorizing the City Administrator and City Engineer to develop plans and specifications based on the preliminary cost estimates for a lift station at 22nd Street and Walnut Creek.
 - N. Consider approving the purchase of a new John Deere 524 P Wheel Loader from Murphy Tractor & Equipment Co. for \$141,536.
 - O. Consider adopting Resolution 2021-04: A resolution establishing the Master Fee Schedule for fiscal year 2020-2021.
 - P. Mayor's Proclamation of Friday April 30, 2021 as Arbor Day.
5. **Petitions - Communications - Citizen Concerns**
- Citizen testimony may be limited to 3 minutes per person.
 - Please do not repeat testimony that has already be heard.
 - No action can be taken on matters presented under this title except to answer any questions or to refer the matter for further action.
6. **Officers' Reports**
- Reports may be given by Officers, Departments, Committees, or Councilmembers concerning the current operations of the City.
 - No action can be taken on matters presented under this title except to answer any questions or to refer the matter for further action.
7. **Adjournment**

Disclaimers & Notices

- The Council may enter into closed session to discuss any matter on this agenda when it is determined that a closed session is clearly necessary for the protection of the public interest or the prevention of needless injury to the reputation of an individual (if such individual has not requested a public meeting) or as otherwise allowed by law. Any closed session shall be limited to the subject matter for which the closed session was called. If the motion to close passes, then immediately prior to the closed session the Mayor shall restate on the record the limitation of the subject matter of the closed session.

- The City of Crete assures that no person shall on the grounds of race, color, national origin, age, disability, handicap or sex, be excluded from participation in, be denied the benefits of, or be otherwise subjected to discrimination under any program or activity of the City receiving Federal financial assistance. To report discrimination, contact the City Clerk's office.
- The complete agenda with attachments is available at www.crete.ne.gov.



CITY COUNCIL LEGISLATIVE/DEVELOPMENT COMMITTEE MEETING

April 6, 2021 at 5:00 PM
Crete City Hall, 243 East 13th Street

MINUTES

Notice of the meeting was given by posting, the appointed method for giving notice as shown by the attached notice, at the following locations:

City Hall, 243 East 13th Street
Post Office, 1242 Linden Avenue
City Bank and Trust, 1135 Main Avenue

Advance notice of the meeting was also given to committee members. Pursuant to Section 84-1412(8) of the Nebraska Open Meetings Act, the City has posted a current copy of the Open meetings Act, Laws of the State of Nebraska, in the back of the council chambers. All proceedings shown were taken while the meeting was open to the attendance of the public.

1. Open Meeting

2. Roll Call

Kyle Frans: Present

Ryan Hinz: Present

Jack Oelschlager: Present

Present: 3.

3. Items of Business

3.A. Discuss and provide a recommendation to the City Council on enacting Ordinance 2122: An ordinance relating to appointed officials.

Recommend City Council approval of Ordinance 2122. Carried with a motion by Jack Oelschlager and a second by Kyle Frans.

Kyle Frans: Aye, Ryan Hinz: Aye, Jack Oelschlager: Aye

Aye: 3, No: 0

3.B. Discuss and provide a recommendation to the City Council on enacting Ordinance 2123: An ordinance relating to rates, fees, and charges.

Recommend City Council approval of Ordinance 2123 Carried with a motion by Jack Oelschlager and a second by Kyle Frans.

Kyle Frans: Aye, Ryan Hinz: Aye, Jack Oelschlager: Aye

Aye: 3, No: 0

4. Officers' Reports

5. Adjournment

Recorded by Acting City Clerk Jerry Wilcox



CITY COUNCIL PUBLIC SAFETY COMMITTEE MEETING

April 6, 2021 at 5:00 PM
Crete City Hall, 243 East 13th Street

MINUTES

Notice of the meeting was given by posting, the appointed method for giving notice as shown by the attached notice, at the following locations:

City Hall, 243 East 13th Street
Post Office, 1242 Linden Avenue
City Bank and Trust, 1135 Main Avenue

Advance notice of the meeting was also given to committee members. Pursuant to Section 84-1412(8) of the Nebraska Open Meetings Act, the City has posted a current copy of the Open meetings Act, Laws of the State of Nebraska, in the back of the council chambers. All proceedings shown were taken while the meeting was open to the attendance of the public.

1. Open Meeting

2. Roll Call

Ryan Hinz: Present

Jack Oelschlager: Present

Dale Strehle: Present

Present: 3.

3. Items of Business

3.A. Discuss and provide a recommendation to the City Council on approving the purchase of five sets of firefighting gear for \$18,515 from Sandry Fire Supply.

Recommend City Council approval of the Sandry Fire Supply quote for 5 sets of firefighting gear for \$18,515.00. Carried with a motion by Ryan Hinz and a second by Dale Strehle.

Ryan Hinz: Aye, Jack Oelschlager: Aye, Dale Strehle: Aye

Aye: 3, No: 0

Brandan Smejdir was present from the Fire Department to explain that the 5 sets of gear are the same as was budgeted, ordered and purchased last year.

3.B. Discuss and provide a recommendation to the City Council on approving the Fire Department's request to submit a grant application to the Emergency Drinking Water for Wildland Firefighters Program for canned drinking water.

Recommend City Council approval of the grant application for canned water for wildfire fighting by the Fire Department. Carried with a motion by Dale Strehle and a second by Ryan Hinz.

Ryan Hinz: Aye, Jack Oelschlager: Aye, Dale Strehle: Aye
Aye: 3, No: 0

3.C. Discuss adjusting the dates allowed for fireworks sales.

Mayor Bauer explained that he had been contacted about reducing the number of days for fireworks sales.

Dan Papik addressed the committee and requested the reduction in days because he did not sell more fireworks in the expanded time, but had to hire more help.

Larry Koener reported that the Knights of Columbus did sell more in the expanded days and it is an important fund raiser for the group. They also paid over \$8,000 in sales tax last year. The Knights of Columbus are not opposed to fewer days, but their vendor already has this year's product ordered and shipped, so it would be better to make the change for next year.

The committee took the information and will discuss a change in the future.

3.D. Discuss amending the fire pit regulations to change the distance gas and propane fire pits can be from structures or other combustible materials.

Recommend the City Attorney draft an ordinance to change the regulations on gas fire pits to follow manufacturers' recommendations. Carried with a motion by Ryan Hinz and a second by Dale Strehle.

Ryan Hinz: Aye, Jack Oelschlager: Aye, Dale Strehle: Aye
Aye: 3, No: 0

Mayor Bauer reported that he has had requests to change the regulations on gas fire pits. He did some research and the contacts he made suggested that the regulations for gas fire pits be changed to follow the manufacturer's recommendations. Also, the wood fire pits should remain at 25 feet from buildings.

3.E. Discuss the creation of an Investigative Sergeant position within the Police Department and the appropriate wage/salary of such position.

City Administrator Tom Ourada reported that the Civil Service Commission will be working on a new, not additional, position for the Police Department. Current trends are an increase in high tech crimes that require special investigative methods. It is recommended that an investigative sergeant position be created and filled prior to filling the patrol officer position that is vacant. The committee will be updated on this procedure as it moves forward.

4. Officers' Reports

5. Adjournment

Recorded by Acting City Clerk Jerry Wilcox



Public Works Committee Meeting
April 6, 2021
5:22 p.m.
Crete Public Library Community Room

Roll Call:

Committee Members Present:

Dale Strehle
Travis Sears

Others Present:

Tom Ourada, City Administrator
Dave Bauer, Mayor
Kyle Frans, Council Person
Ryan Hinz, Council Person
Jack Oelschlager, Council Person

Kyle Manley, City Attorney
Jerry Wilcox, Finance Director
Steve Hensel, Police Chief
Brad Bailey, Building Inspector
Kelsey Sisouvang, Book keeper
Nathan Boone, JEO

Special Order of Business

A. JEO Contract for development of Utility Emergency Response Plan:

Tom informed the Council that the emergency response plan is required by law and JEO is very capable of doing it. He recommends to move forward with the contract. Travis motioned to enter the contract for \$22,085 with JEO for development of a Utility Emergency Response Plan. Dale seconds. Travis, yes. Dale, yes.

B. Adjusting 12th & Norman City Parking Lot Monthly Rates for Volume Pricing:

Mayor Bauer has had requests on lowering the parking rate for volume pricing, one of them wanting 10 spots at a reduced price of \$15 a spot instead of the normal \$25. Doing a 12 month lease or commitment, with option for renewal, was suggested for that request. Dale motioned to do a 12 month lease for 10 parking spots at \$15 a spot in the 12th & Norman city parking lot. Travis seconds. Dale, yes. Travis, yes.

C. Speece Lewis Contract for Engineering Services Related to 22nd Street Box Culvert Project:

Speece Lewis submitted a contract for \$28,350 to design the box culvert on 22nd Street. Tom recommended to go through with the contract. Travis motioned to enter the contract for \$28,350 with Speece Lewis for engineering services for the 22nd Street Box Culvert Project. Dale seconds. Travis, yes. Dale, yes.

D. Approving Bid for Wildwood Pool Splashpad Project:

Tom recommends to table approving the bid, as he does not have a bid back from JEO yet. Travis motioned to table the Wildwood Pool Splashpad project to the next scheduled council meeting. Dale seconds. Travis, yes. Dale, yes.

E. Approving Engineering Plans for the North Crete 2021 Gap Paving Project & Setting a Bid Letting Date:

Senior Project Manager at JEO, Nathan Boone, handed out and talked through the design for gap paving 18th, 19th, 20th and 24th between Norman and Main, and Norman from 23rd to 24th. He discussed paving streets, some driveways and alleys and answered questions about right of ways and responsibility of upkeep. A bid letting date was set for May 13th at 11:00am. Travis motioned to approve the engineer plans for the North Crete 2021 Gap Paving Project, with the changes to 24th Street, and set a bid letting date of May 13th at 11:00am. Dale seconds. Travis, yes. Dale, yes.

Officer's Report

Adjournment

Meeting Adjourned at 5:52 p.m.

Dale Strehle, Chairman



CITY COUNCIL REGULAR MEETING

April 6, 2021 at 6:00 PM

Crete City Hall, 243 East 13th Street

MINUTES

Notice of the meeting was given by posting and publishing in The Crete News, the appointed method for giving notice as shown by the Proof of Publication attached to the minutes. Advance notice of the meeting was also given to the Mayor and City Council. Pursuant to Section 84-1412(8) of the Nebraska Open Meetings Act, the City has posted a current copy of the Open Meetings Act, Laws of the State of Nebraska in the back of the Council Chambers. Additional copies are available to read. The City may consider items listed on the agenda in random order. All proceedings shown were taken while the meeting was open to the attendance of the public.

Those in attendance pledged allegiance to the flag.

1. Open Meeting

2. Roll Call

Brian Carnes: Absent
Kyle Frans: Present
Ryan Hinz: Present
Jack Oelschlager: Present
Travis Sears: Present
Dale Strehle: Present

Present: 5, Absent: 1.

3. Consent Agenda

Approve the consent agenda items as presented. Carried with a motion by Dale Strehle and a second by Travis Sears.

Kyle Frans: Aye, Ryan Hinz: Aye, Jack Oelschlager: Aye, Travis Sears: Aye, Dale Strehle: Aye
Aye: 5, No: 0

3.A. Approve Meeting Minutes

3.A.1. Legislative and Economic Development Committee meeting minutes of March 16, 2021.

3.A.2. Finance Committee meeting minutes of March 16, 2021.

3.A.3. City Council Meeting Minutes of March 16, 2021.

3.B. Accept the City Treasurer's Report

3.C. Approve the Payment of Claims Against the City

4. Items of Business

4.A. Consider Trip Reynolds's request to limit the use by the public of Crete Public Schools athletic facilities.

Trip Reynolds showed some pictures of activities at the Crete High School Track and suggested that maybe the City would be able to pass an ordinance similar to one in Omaha that would prohibit some activities on specific public properties.

Council member Frans suggested that Mr. Reynolds make his presentation to the Crete School Board. Reynolds reported that he has contacted the board via letter and email and has not gotten a response from anyone in several months.

Mayor Bauer suggested that the City Attorney could review the information provided by Reynolds and determine if there is any action the City Council can take.

4.B. Consider granting Sean Tillery's request for an extended stay at Tuxedo Park from April to October.

City Administrator reported that Sean Tillery recently opened a skydiving business at the Crete Airport, is building a new house and would like to stay at the Tuxedo Park Campground through October 2021.

Approve the request of Sean Tillery for a long term stay at Tuxedo Park Campground through October 2021 Carried with a motion by Dale Strehle and a second by Travis Sears.

Kyle Frans: Aye, Ryan Hinz: Aye, Jack Oelschlager: Aye, Travis Sears: Aye, Dale Strehle: Aye
Aye: 5, No: 0

4.C. Consider approving the engineering plans for the North Crete 2021 Gap Paving Project and setting a bid letting date.

City Administrator Tom Ourada reviewed the plans as prepared by JEO Consulting. The Public Works Committee has reviewed the plans and suggested that some sidewalk be added to the northwest section of the 24th Street project. Ourada reported that he and the engineer would get the additional sidewalk added to meet expectations. The engineer had recommended to the committee to open bids on May 13, 2021 at 11 AM.

Approve the engineering plans for the 18th, 19th, 20th, 24th and Norman gap paving projects with the addition of some sidewalk to the 24th Street project and set the bid opening date for May 13, 2021 at 11:00 AM. Carried with a motion by Dale Strehle and a second by Travis Sears.

Kyle Frans: Aye, Ryan Hinz: Aye, Jack Oelschlager: Aye, Travis Sears: Aye, Dale Strehle: Aye
Aye: 5, No: 0

4.D. Consider approving the purchase of five sets of firefighting gear for \$18,515 from Sandry Fire Supply.

The Public Safety Committee met and discussed the request to order five sets of firefighting gear. The new gear is part of a budgeted plan to purchase new gear annually to keep everyone in compliant equipment.

Approve the purchase of five sets of personal firefighting protective gear from Sandry Fire Supply at a cost of \$18,515. Carried with a motion by Jack Oelschlager and a second by Ryan Hinz.

Kyle Frans: Aye, Ryan Hinz: Aye, Jack Oelschlager: Aye, Travis Sears: Aye, Dale Strehle: Aye
Aye: 5, No: 0

4.E. Consider approving the Fire Department's request to submit a grant application to the Emergency Drinking Water for Wildland Firefighters Program for canned drinking water.

The Public Safety Committee reviewed the Fire Department request to apply for a grant of canned drinking water for use to hydrant personnel during wildfires. It is a no cost grant.

Approve the Fire Department applying for a no cost grant of canned water for personnel during wildfires. Carried with a motion by Jack Oelschlager and a second by Ryan Hinz.

Kyle Frans: Aye, Ryan Hinz: Aye, Jack Oelschlager: Aye, Travis Sears: Aye, Dale Strehle: Aye
Aye: 5, No: 0

4.F. Consider entering into a contract for \$22,085 with JEO for the development of a Utility Emergency Response Plan.

City Administrator reported on the requirement to develop a Utility Emergency Response Plan. JEO Consulting has experience in working with the Nebraska Emergency Management Agency and developing these plans.

Approve the contract with JEO Consulting for the Emergency Response Plan at a cost of \$22,085. Carried with a motion by Dale Strehle and a second by Travis Sears.

Kyle Frans: Aye, Ryan Hinz: Aye, Jack Oelschlager: Aye, Travis Sears: Aye, Dale Strehle: Aye
Aye: 5, No: 0

4.G. Consider adjusting the monthly rates on parking spaces in the city parking lot at 12th and Norman for volume pricing.

City Administrator Tom Ourada reported that he has received a request again for a reduced parking rate in the paved lot at 12th and Norman for 10 or more spots.

Approve a volume parking rate for the paved lot at 12th and Norman at \$15 per spot for a term of 12 months for 10 or more spaces. Carried with a motion by Dale Strehle and a second by Travis Sears.

Kyle Frans: Aye, Ryan Hinz: Aye, Jack Oelschlager: Aye, Travis Sears: Aye, Dale Strehle: Aye
Aye: 5, No: 0

4.H. Consider entering into a contract for \$28,350 with Speece Lewis for engineering services related to the 22nd Street box culvert project.

City Administrator Tom Ourada reported that Speece Lewis Engineering contends that a box culvert will work on Walnut Creek at 22nd Street at a cost of less than \$1,000,000 to include the sewer lift station. Other firms suggested a bridge at a cost of over \$2,000,000.

Approve a contract with Speece Lewis to design a box culvert and lift station on Walnut Creek at 22nd Street at a cost of \$28,350. Carried with a motion by Dale Strehle and a second by Travis Sears.

Kyle Frans: Aye, Ryan Hinz: Aye, Jack Oelschlager: Aye, Travis Sears: Aye, Dale Strehle: Aye
Aye: 5, No: 0

4.I. Review and consider approving the bid for the Wildwood Pool Splashpad project.

City Administrator Tom Ourada explained that the only bid came in a little high so the engineer and contractor are working negotiating. They have not provided the City with any additional information at this point.

Table this item until the April 20, 2021 meeting. Carried with a motion by Dale Strehle and a second by Travis Sears.

Kyle Frans: Aye, Ryan Hinz: Aye, Jack Oelschlager: Aye, Travis Sears: Aye, Dale Strehle: Aye
Aye: 5, No: 0

4.J. Consider enacting Ordinance 2122: An ordinance relating to appointed officials.

City Administrator Tom Ourada explained that the ordinance would change the officers that the Mayor has to appoint to match state statute and it addresses the combining of the City Clerk and City Treasurer offices if the City Council wishes to do so

Introduce ordinance 2122 and suspend the rule requiring reading on three separate days Carried with a motion by Ryan Hinz and a second by Kyle Frans.

Kyle Frans: Aye, Ryan Hinz: Aye, Jack Oelschlager: Aye, Travis Sears: Aye, Dale Strehle: Aye
Aye: 5, No: 0

Approve ordinance 2122 on final reading Carried with a motion by Ryan Hinz and a second by Kyle Frans.

Kyle Frans: Aye, Ryan Hinz: Aye, Jack Oelschlager: Aye, Travis Sears: Aye, Dale Strehle: Aye
Aye: 5, No: 0

4.K. Consider enacting Ordinance 2123: An ordinance relating to rates, fees, and charges.

City Administrator Tom Ourada explained that the ordinance takes rates, fees and charges from throughout the City Code and allows for them all to be set by resolution, with the exception of taxes, which will still have to be set by ordinance.

Introduce ordinance 2123 and suspend the rule requiring reading on three separate days Carried with a motion by Ryan Hinz and a second by Kyle Frans.

Kyle Frans: Aye, Ryan Hinz: Aye, Jack Oelschlager: Aye, Travis Sears: Aye, Dale Strehle: Aye
Aye: 5, No: 0

Approve ordinance 2123 on final reading Carried with a motion by Ryan Hinz and a second by Kyle Frans.

Kyle Frans: Aye, Ryan Hinz: Aye, Jack Oelschlager: Aye, Travis Sears: Aye, Dale Strehle: Aye
Aye: 5, No: 0

5. Petitions - Communications - Citizen Concerns

6. Officers' Reports

City Administrator Tom Ourada reported the following:

- Introduced the new HR Coordinator Wendy Thomas to the City Council
- The American Recovery Act could provide up to \$1,180,000 to the City for Covid 19 related expenses
- Allo is still showing interest in providing internet service to the citizens of Crete
- The information discussed on the 22nd Street box culvert earlier is encouraging for an affordable option to keep the street open
- Sanitary issues are becoming concerning to the NDEE and annexation should be considered so that a sewer project can be done
- An updated photo of the Tuxedo Park Road Bridge shows that the deck appears to be all in place
- All city employees have plans in place for Covid 19 vaccinations
- The Library will be having an open house on April 9th and 10th

7. Adjournment

The meeting adjourned at 6:47 PM.

Mayor

(SEAL)

Acting City Clerk

I, Jerry Wilcox, Acting City Clerk for the City of Crete, hereby certify that the foregoing is a true and correct copy of the proceedings had and done by the Mayor and Council. I hereby certify that a copy of the Open Meetings Act was posted in the back of the Council Chambers. I certify that all of the subjects included in the foregoing proceedings were contained in the agenda

for the meeting, kept continually current and available for public inspection at the office of the City Clerk. I certify that such subjects were contained in said agenda for at least twenty-four hours prior to said meeting and that at least one copy of all reproducible material discussed at the meeting was available at the meeting for examination and copying by members of the public. I certify that the minutes were in written form and available for public inspection within ten working days and prior to the next convened meeting of the City Council. I certify that all news media requesting notification concerning meetings of the City Council were provided with advance notification of the time and place of said meeting and the subjects to be discussed.

Acting City Clerk

(S E A L)

CITY COUNCIL

CLAIMS PAID

Payee	Description	Amount
AMERITAS	ELECTIVE VISION INSURANCE	\$26.02
BLACK HILLS ENERGY	NATURAL GAS	\$277.67
BNSF RAILWAY COMPANY	CROSSING PERMIT	\$1,800.00
CITY PAYROLL FUND	WAGES	\$88,551.68
CITY TAX FUND	LIBRARY DONATION NESTLE	\$1,000.00
CORE & MAIN LP	SUPPLIES	\$6,260.79
CORNHUSKER INTERNATIONAL	PARTS	\$62.63
CRETE FOODMART	SUPPLIES	\$14.20
CRETE POSTMASTER	POSTAGE	\$1,080.54
DUTTON LAINSON COMPANY	SUPPLIES	\$1,905.98
EAKES OFFICE SOLUTIONS	SUPPLIES	\$2,793.81
GRAINGER	SUPPLIES	\$267.74
GRAYBAR ELECTRIC COMPANY	SUPPLIES	\$9,774.71
HEARTLAND NATURAL GAS	NATURAL GAS	\$304.20
JEO CONSULTING GROUP INC.	ENGINEERING	\$4,352.50
LINCOLN WINWATER WORKS	SUPPLIES	\$664.35
MAX I WALKER UNIFORM	UNIFORMS	\$189.16
M.E.A.N.	PURCHASED POWER	\$712,272.41
NeHHS LAB	LABS	\$120.00
NEBRASKALAND TIRE INC	TIRES	\$100.99
NETTIFEE, DIANN	REIMBURSEMENT	\$64.37
OLSSON	ENGINEERING	\$4,931.68
SEWARD COUNTY NEWS	PUBLICATION	\$13.91
SID DILLON FORD	PARTS	\$27.89
SOLOMON CORPORATION	TRANSFORMER PARTS	\$6,267.25
U.S. BANK	SUPPLIES	\$1,236.66
UNITE PRIVATE NETWORKS	ETHERNET INTERNET ACCESS	\$1,452.00
UPS	POSTAGE	\$12.46
VAN KIRK BROS CONTRACTING	CONSTRUCTION	\$28,330.35
WILBER PLUMBING, HEATING	REPAIR HEATER	\$139.95
UTILITY FUNDS	SUBTOTAL	\$874,295.90
AKRS EQUIPMENT	OIL/AIR FILTERS	\$53.93
ALL COPY PRODUCTS INC	KONICA LEASE	\$241.88
ALL MAKES OFFICE EQUIPMENT	OFFICE EQUIPMENT	\$451.24
AMERITAS	ELECTIVE VISION INSURANCE	\$156.04
ASSN OF THREAT ASSESSMENT	MEMBERSHIP	\$250.00
BADGER BODY & TRUCK EQUIP	LED LIGHTS	\$271.00
BAKER & TAYLOR	BOOKS/MAGAZINES	\$579.78
BEATRICE CONCRETE CO	CONCRETE	\$6,683.88
BLACK HILLS ENERGY	NATURAL GAS	\$1,005.56
BLUE VALLEY DOOR CO INC	SPRING REPAIR	\$2,272.74
BOUND TREE MEDICAL LLC	MEDICAL SUPPLIES	\$296.89
BRETHOUWER, SETH	REFUND ACTIVITY FEE	\$45.00
B'S ENTERPRISE INC	GRADER BLADES	\$3,439.00

APRIL 4, 2021

PAGE 1

CITY COUNCIL

CLAIMS PAID

Payee	Description	Amount
BSN SPORTS INC	POOL WHISTLES	\$702.46
CARROT-TOP INDUSTRIES INC	FLAGS, HALYARD & HOOKS	\$171.76
CDW GOVERNMENT INC	CITY HALL REMODEL	\$1,091.86
CENGAGE LEARNING INC/GALE	BOOKS/MAGAZINES	\$65.57
CENTER POINT LARGE PRINT	BOOKS/MAGAZINES	\$23.37
CITY PAYROLL FUND	WAGES	\$111,725.14
CITY REVENUE FUND	FUEL	\$5,285.92
CONTECH ENGINEERED SOLUTIONS	SUPPLIES	\$504.00
CORNHUSKER INTERNATIONAL	PARTS	\$41.21
CRETE AREA MEDICAL CENTER	ALS SERVICE FEE	\$529.23
CRETE FOODMART	OFFICE SUPPLIES	\$62.02
CRETE GLASS	TEMPERED GLASS	\$241.00
CRETE LUMBER & FARM SUPPLY	SUPPLIES	\$130.58
CRIST TOWING SERVICE	TOWING	\$155.50
DELL MARKETING LP	COMPUTERS	\$824.06
DIAMOND VOGEL PAINT CENTER	PAINT	\$2,173.45
DISPLAYS2GO	POOL PRICING SIGN	\$590.79
EAKES OFFICE SOLUTIONS	SUPPLIES	\$760.37
ENGINEERED CONTROLS INC	SUPPLIES	\$812.46
ESCALANTE, JESSICA	SOCCER REFUND	\$45.00
FIRST NATIONAL BANK OF OMAHA	SUPPLIES	\$934.66
GENERAL FIRE & SAFETY EQUIP	RECHARGE FIRE EXTINGUISHERS	\$264.35
HEARTLAND NATURAL GAS	NATURAL GAS	\$110.42
HEATH SPORTS	T-SHIRTS MICRO SOCCER	\$940.97
JANWAY COMPANY	OFFICE SUPPLIES	\$363.58
JAY'S OIL CO.	TIRE REPAIR	\$25.00
JEBRO INC	PARTS	\$100.00
JEO CONSULTING GROUP INC.	ENGINEERING	\$6,229.74
MATHESON TRI-GAS INC	OXYGEN	\$164.61
MENARDS - LINCOLN SOUTH	CITY HALL REMODEL	\$107.94
MIDWEST SERVICE AND SALES	SUPPLIES	\$1,929.82
MILFORD PLUMBING INC	SUPPLIES	\$865.70
NAPA AUTO PARTS	PARTS	\$327.95
NEBRASKA.GOV	JUSTICE CASE LISTING	\$2.00
NMC LLC	PARTS	\$6,587.75
ORSCHELN FARM AND HOME	SUPPLIES	\$47.65
PRESTO-X	PEST CONTROL	\$60.00
PURCHASE POWER	POSTAGE	\$300.00
QUADIANT FINANCE USA INC	POSTAGE	\$100.00
QUILL CORP.	OFFICE SUPPLIES	\$72.70
ROSE EQUIPMENT LLC	PARTS	\$1,542.56
SACK LUMBER CO	SUPPLIES	\$969.25
SAPP BROS, INC - LINCOLN	FUEL	\$420.00
SEWARD COUNTY INDEPENDENT	PUBLICATION	\$75.17

APRIL 4, 2021

PAGE 2

CITY COUNCIL
CLAIMS PAID

Payee	Description	Amount
SID DILLON FORD	PARTS	\$33.49
SILVER STATE CONSULTING GROUP	TRAINING	\$525.00
SPARQDATA	SUBSCRIPTION	\$3,000.00
TREETOP PRODUCTS INC	BENCHES	\$1,732.10
U.S. BANK	SUPPLIES	\$1,104.70
UNION BANK & TRUST CO	BOND INTEREST	\$624.00
UNITE PRIVATE NETWORKS LLC	ETHERNET INTERNET ACCESS	\$748.00
VERIZON WIRELESS	PHONES	\$338.02
WINDSTREAM	PHONE LINES	\$1,364.51
XPRESS BILL PAY	ONLINE CC FEES	\$612.14
TAX FUNDS	SUBTOTAL	\$174,306.47
ALL FUNDS	TOTAL	\$1,048,602.37

**City of Crete
Treasurer's Report**

	fy 2021	2/28/2021	Cash	Budget	Year to date	Percent	Budget	Year to date	Percent
	41.67%	Fund	Balance	Revenue	Revenue	Revenue	Expense	Expense	Expense
UTILITIES	001-1000	Electric Fund	\$3,237,684.46	\$10,640,161.00	\$4,496,091.11	42%	\$10,849,050.00	\$3,689,817.74	34%
	001-1005	Consumer Deposit	\$154,040.18						
	001-1006	Consumer Deposit CDs	\$348,000.00						
	001-1009	Pinnacle ACH	\$5,310.58						
	001-1015	Electric CDs	\$3,375,869.53						
	002-1000	Water Fund	-\$30,805.86	\$883,780.00	\$501,307.54	57%	\$1,074,160.00	\$368,649.43	34%
	002-1015	Water CDs	\$400,000.00						
	003-1000	Sewer Fund	\$1,657,760.50	\$1,622,600.00	\$811,008.49	50%	\$2,100,600.00	\$1,094,236.96	52%
	003-1002	Sewer USDA Equipment	\$109,455.14						
	003-1003	Sewer USDA Reserve	\$301,237.30						
AIRPORT	050-1010	Airport Purposes	\$222,200.02	\$300,000.00	\$132,882.48	44%	\$300,000.00	\$49,660.37	17%
GENERAL	101-1000	General Fund	-\$171,950.76	\$3,660,700.00	\$1,022,175.49	28%	\$3,660,700.00	\$1,501,993.63	41%
	101-1042	Brick Fund	\$622.85						
	102-1015	City Sales Tax	\$308,171.87	\$884,000.00	\$878,577.74	99%	\$884,000.00	\$682,530.87	77%
	103-1000	Keno Fund	\$144,166.28	\$60,000.00	\$46,719.10	78%	\$60,000.00	\$17,995.00	30%
	103-1007	Keno Prize Reserve	\$93,961.66						
	103-1015	Keno Savings	\$43,173.38						
	135-1000	Firemen's Agency	\$5.00	\$0.00	\$0.00	0%	\$0.00	\$0.00	0%
	150-1000	General Obligation Bonds	\$32,628.83	\$495,300.00	\$174,005.18	35%	\$557,000.00	\$339,191.50	61%
	150-1015	LB357 Bond Reserve UBT	\$147,491.99						
	171-1000	Insurance Contingency	\$107,138.41	\$0.00	\$0.00	0%	\$110,000.00	\$0.00	0%
	173-1000	Capital Reserve Checking	\$815,975.96	\$63,000.00	\$299,113.93	475%	\$16,000.00	\$6,550.00	41%
173-1043	Capital Reserve Savings	\$252,619.30							
POLICE	201-1000	Police Department	\$251,936.56	\$1,669,860.00	\$715,223.57	43%	\$1,669,860.00	\$713,933.78	43%
	202-1000	Communications Center	\$142,035.48	\$306,900.00	\$128,815.00	42%	\$306,900.00	\$140,266.94	46%
	203-1000	Community Service	\$69,658.17	\$68,850.00	\$28,395.75	41%	\$68,850.00	\$18,481.35	27%
	204-1000	Stop Fund	\$1,985.28	\$200.00	\$0.00	0%	\$200.00	\$0.00	0%

24

**City of Crete
Treasurer's Report**

	fy 2021	2/28/2021	Cash		Budget	Year to date	Percent		Budget	Year to date	Percent
	41.67%	Fund	Balance		Revenue	Revenue	Revenue		Expense	Expense	Expense
FIRE & RESCUE	301-1000	Fire Dept. Maintenance	\$7,917.38		\$130,200.00	\$55,415.00	43%		\$130,200.00	\$88,519.09	68%
	302-1000	Rescue	-\$50,931.93		\$375,000.00	\$102,719.65	27%		\$385,500.00	\$161,567.02	42%
	303-1000	Fire Equipment	-\$38,188.80		\$89,600.00	\$14,896.88	17%		\$59,600.00	\$41,182.47	69%
	304-1000	Fire Equipment II	\$161,179.49		\$321,000.00	\$220,516.13	69%		\$515,000.00	\$97,895.42	19%
	304-1043	Fire Equipment II Savings	\$152,494.59								
	304-1015	Fire Equipment II CDs	\$102,669.84								
STREETS	401-1000	Street & Grade	\$957,669.84		\$905,350.00	\$532,848.24	59%		\$936,350.00	\$406,640.74	43%
PUBLIC WORKS	501-1000	City Hall	\$52,025.34		\$45,950.00	\$19,159.00	42%		\$45,950.00	\$27,366.48	60%
	502-1000	Community Center	\$59,110.42		\$14,550.00	\$5,045.00	35%		\$14,550.00	\$4,202.41	29%
	503-1000	Community Room/Shelter	-\$6,207.55		\$0.00	\$0.00	0%		\$0.00	\$5,196.99	0%
	511-1000	Transfer Station	\$103,249.87		\$35,000.00	\$24,741.80	71%		\$35,000.00	\$13,383.94	38%
	512-1000	Landfill Reserve	\$244,658.57		\$11,000.00	\$3,210.00	29%		\$0.00	\$0.00	0%
	521-1000	Parks Maintenance	\$40,383.91		\$278,640.00	\$113,662.28	41%		\$278,640.00	\$104,090.10	37%
	522-1000	Swimming Pool Maintenance	\$141,364.51		\$49,900.00	\$20,000.00	40%		\$49,900.00	\$6,431.50	13%
	531-1000	Capitol Outlay	\$163,517.03		\$173,315.00	\$58,335.00	34%		\$264,800.00	\$67,624.31	26%
	531-1015	Capitol Outlay CDs	\$90,000.00								
	532-1000	Capitol Improvements	-\$407,735.48		\$1,993,700.00	\$19,008.78	1%		\$1,993,700.00	\$160,473.37	8%
	532-1043	Capitol Improvements BANs	\$93,241.48								
551-1000	FEMA Disaster	-\$1,079.40		\$20,000.00	\$0.00	0%		\$16,700.00	\$0.00	0%	
CEMETERY	601-1000	Cemetery Maintenance	\$65,373.51		\$79,780.00	\$35,853.80	45%		\$79,780.00	\$26,757.41	34%
	601-1010	Kuncl Memorial Fund	\$5,059.81								
	601-1014	Maintenance Perpetual CD	\$20,000.00								
	601-1015	Maintenance CDs	\$12,000.00								
	602-1000	Cemetery Perpetual Care	\$12,214.12		\$2,000.00	\$1,046.90	52%		\$1,000.00	\$241.00	24%
	602-1010	Moser/Chrastil Memorial Fund	\$1,155.94								
	602-1015	Perpetual Care CDs	\$107,000.00								

**City of Crete
Treasurer's Report**

	fy 2021	2/28/2021	Cash		Budget	Year to date	Percent		Budget	Year to date	Percent
	41.67%	Fund	Balance		Revenue	Revenue	Revenue		Expense	Expense	Expense
CULTURE & RECREATION	701-1000	Library Operations	\$192,591.73		\$505,475.00	\$207,859.68	41%		\$505,475.00	\$229,086.37	45%
	702-1000	Library Reserve	-\$183,014.60		\$17,775.00	\$5,558.55	31%		\$252,775.00	\$1,811.84	1%
	702-1014	Library Reserve CDs	\$115,000.00								
	702-1015	Library Reserve CDs	\$121,000.00								
	721-1000	Recreation Programs	\$196,051.80		\$60,500.00	\$22,034.19	36%		\$85,860.00	\$25,901.49	30%
	722-1000	Swimming Pool Programs	\$33,473.30		\$105,350.00	\$22,665.00	22%		\$105,350.00	\$5,594.96	5%
COMMUNITY DEVELOPMENT	801-1000	Economic Development	-\$556,730.64		\$415,000.00	\$171,346.99	41%		\$1,395,000.00	\$388,902.71	28%
	801-1014	ED Loan Guarantee Fund	\$358,234.22								
	801-1043	LB840 Savings	\$1,031,433.40								
	802-1000	Tax Increment Financing	\$156,127.78		\$20,000.00	\$38,840.00	194%		\$10,000.00	\$1,328.00	13%
	810-1000	CCCCFF Theater	-\$59,943.40		\$312,500.00	\$0.00	0%		\$282,500.00	\$2,731.58	1%
	851-1000	CDBG Housing	-\$2,758.27		\$0.00	\$1.56	0%		\$0.00	\$0.00	0%
	851-1043	Housing Savings	\$37,527.82								
	852-1000	CDBG DTR	\$1,630.59		\$550,000.00	\$0.00	0%		\$470,000.00	\$0.00	0%
853-1000	CDBG Streets	\$0.00		\$0.00	\$0.00	0%		\$0.00	\$0.00	0%	
MISC.	951-1000	Payroll	\$57,392.68								
	952-1010	Health Insurance	\$29,372.31		\$17,000.00	\$1,053.00	6%		\$17,000.00	\$7,290.36	43%
	953-1010	Cafeteria Fund	\$1,408.55								
	Totals		\$15,637,311.87		\$27,183,936.00	\$10,930,132.81	40%		\$29,587,950.00	\$10,497,551.13	35%

**City of Crete
Treasurer's Report**

fy 2021 41.67%	2/28/2021 Fund	Cash Balance	Budget Revenue	Year to date Revenue	Percent Revenue	Budget Expense	Year to date Expense	Percent Expense
	Revenue Funds	\$9,558,551.83	\$13,146,541.00	\$5,808,407.14	44%	\$14,023,810.00	\$5,152,704.13	37%
	General Funds	\$1,774,004.77	\$5,163,000.00	\$2,420,591.44	47%	\$5,287,700.00	\$2,548,261.00	48%
	Police Department	\$465,615.49	\$2,045,810.00	\$872,434.32	36%	\$2,045,810.00	\$872,682.07	30%
	Fire & Rescue Department	\$335,140.57	\$915,800.00	\$393,547.66	43%	\$1,090,300.00	\$389,164.00	36%
	Street Fund	\$957,669.84	\$905,350.00	\$532,848.24	59%	\$936,350.00	\$406,640.74	43%
	Public Works	\$572,528.70	\$2,622,055.00	\$263,161.86	10%	\$2,699,240.00	\$388,769.10	14%
	Cemetery	\$222,803.38	\$81,780.00	\$36,900.70	45%	\$80,780.00	\$26,998.41	33%
	Culture & Recreation	\$475,102.23	\$689,100.00	\$258,117.42	37%	\$949,460.00	\$262,394.66	28%
	Community Development	\$965,521.50	\$1,297,500.00	\$210,188.55	16%	\$2,157,500.00	\$392,962.29	18%
	Airport	\$222,200.02	\$300,000.00	\$132,882.48	44%	\$300,000.00	\$49,660.37	17%
	Miscellaneous	\$88,173.54	\$17,000.00	\$1,053.00	6%	\$17,000.00	\$7,290.36	43%
	Total All Funds	\$15,637,311.87	\$27,183,936.00	\$10,930,132.81	40%	\$29,587,950.00	\$10,497,527.13	35%
			DEBT	Principal	Interest	Total		Annual
			General Obligation	\$913,000.00	\$60,570.00	\$973,570.00		\$335,500.00
			Other Tax Funds	\$6,173,000.00	\$1,868,129.76	\$8,041,129.76		\$241,000.00
			Revenue Funds	\$10,565,546.27	\$1,507,107.68	\$12,072,653.95		\$223,500.00
			Total	\$17,651,546.27	\$3,435,807.44	\$21,087,353.71		\$800,000.00

GROSS SALES

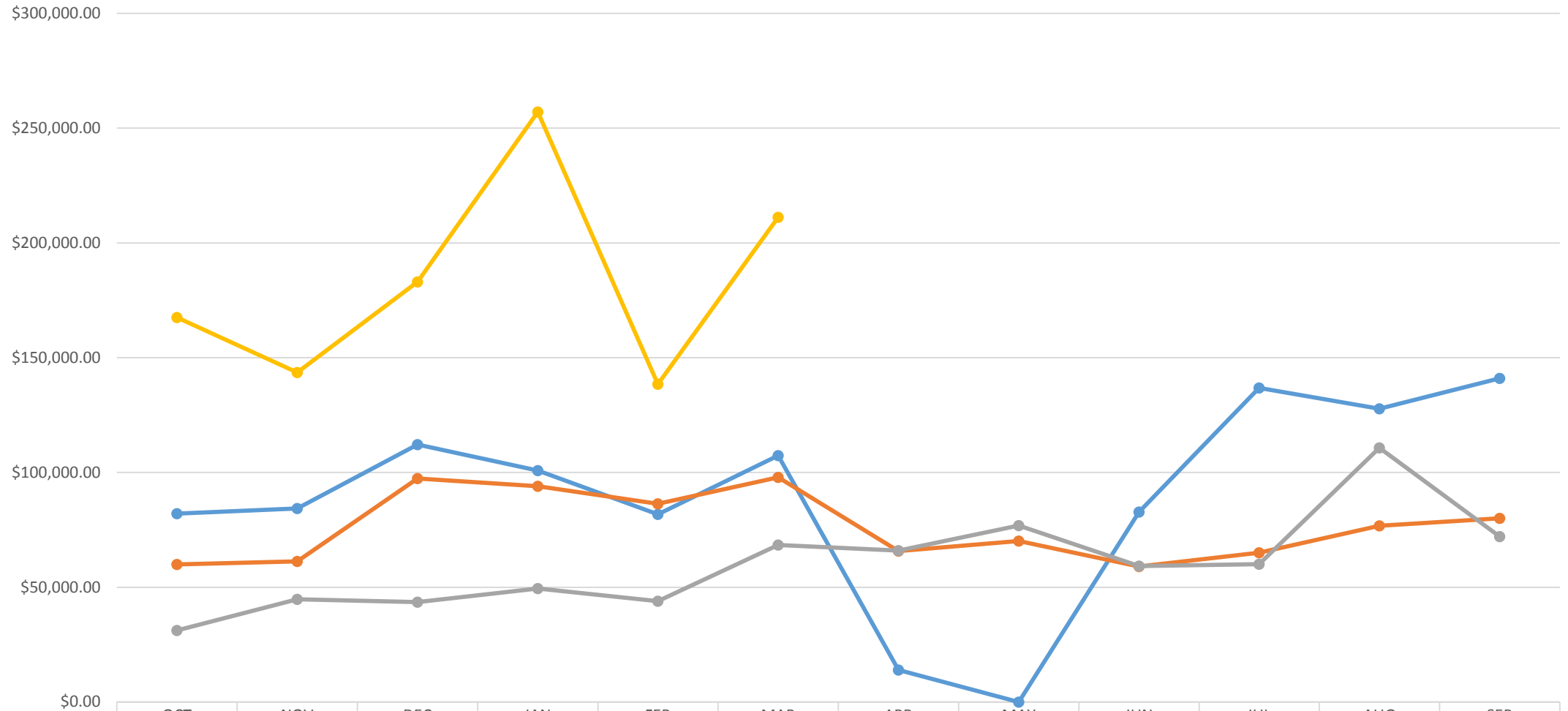

	OCT	NOV	DEC	JAN	FEB	MAR	APR	MAY	JUN	JUL	AUG	SEP
Gross Sales 2021	\$167,500.65	\$143,562.92	\$183,053.28	\$257,115.45	\$138,509.40	\$211,174.56						
Gross Sales 2020	\$82,114.30	\$84,347.94	\$112,176.69	\$100,852.12	\$81,801.89	\$107,413.97	\$13,996.50	\$0.00	\$82,777.35	\$136,862.14	\$127,740.86	\$141,032.24
Gross Sales 2019	\$59,991.95	\$61,227.28	\$97,417.83	\$94,018.74	\$86,348.05	\$97,838.40	\$65,777.09	\$70,189.21	\$59,030.14	\$65,098.75	\$76,753.34	\$80,089.25
Gross Sales 2018	\$31,226.24	\$44,714.38	\$43,562.15	\$49,418.69	\$43,895.80	\$68,412.12	\$66,012.04	\$76,924.49	\$59,273.32	\$60,046.47	\$110,715.19	\$72,048.19

Outlet Commissions

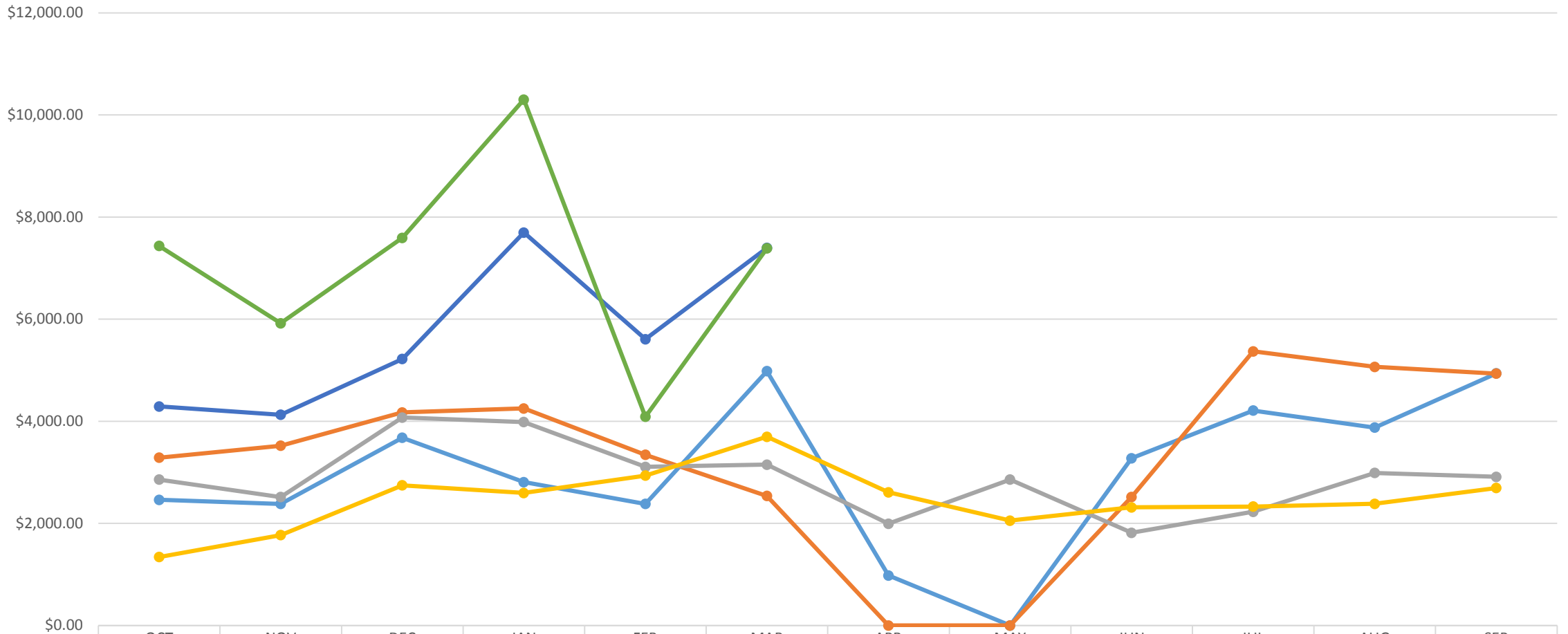

	OCT	NOV	DEC	JAN	FEB	MAR	APR	MAY	JUN	JUL	AUG	SEP
My Bar 2021	\$4,290.12	\$4,128.93	\$5,220.26	\$7,697.07	\$5,607.28	\$7,394.88						
Eagles 2021	\$7,434.93	\$5,920.47	\$7,593.46	\$10,301.01	\$4,088.38	\$7,387.34						
My Bar 2020	\$2,461.40	\$2,382.35	\$3,678.36	\$2,808.42	\$2,382.36	\$4,981.85	\$979.76	\$0.00	\$3,275.85	\$4,209.56	\$3,876.22	\$4,938.83
Eagles 2020	\$3,286.60	\$3,522.01	\$4,174.01	\$4,251.22	\$3,343.78	\$2,537.13	\$0.00	\$0.00	\$2,518.56	\$5,370.79	\$5,065.64	\$4,933.43
My Bar 2019	\$2,858.20	\$2,515.55	\$4,074.29	\$3,984.86	\$3,107.25	\$3,150.61	\$1,994.44	\$2,858.17	\$1,816.63	\$2,227.64	\$2,989.04	\$2,913.00
Eagles 2019	\$1,341.24	\$1,770.36	\$2,744.96	\$2,596.45	\$2,937.12	\$3,698.08	\$2,609.96	\$2,055.08	\$2,315.48	\$2,329.27	\$2,383.70	\$2,693.24

Name	Seq	Type	Description	Invoice Date	Total Cost	PO Number	Period	GL Account
ALL ROADS BARRICADES INC (115)								
ALL ROADS BARRICADES INC	1	Invoice	HIP 24X24-DO NOT ENTE	03/31/2021	63.66	1127	00/00	401-6001
ALL ROADS BARRICADES INC	2	Invoice	HIP 12x18-EMERGENCY	03/31/2021	76.70	1127	00/00	401-6001
ALL ROADS BARRICADES INC	3	Invoice	HIP 12x12-NO PARKING	03/31/2021	121.50	1127	00/00	401-6001
ALL ROADS BARRICADES INC	4	Invoice	HIP 18x18-TYPE 4-3, RED	03/31/2021	49.74	1127	00/00	401-6001
Total ALL ROADS BARRICADES INC (115):					311.60			
APWA (245)								
APWA	1	Invoice	2020/2021 MEMBERSHIP	04/05/2021	540.00		00/00	002-9780
Total APWA (245):					540.00			
ASSN OF THREAT ASSESSMENT (310)								
ASSN OF THREAT ASSESSMENT	1	Invoice	2021 ATAP DUES-DAWN	03/15/2021	125.00		00/00	201-5400
Total ASSN OF THREAT ASSESSMENT (310):					125.00			
BAKER & TAYLOR (370)								
BAKER & TAYLOR	1	Invoice	BOOKS/MAGAZINES	03/23/2021	53.06		00/00	701-5691
BAKER & TAYLOR	1	Invoice	BOOKS/MAGAZINES	03/30/2021	332.50		00/00	701-5691
BAKER & TAYLOR	1	Invoice	BOOKS/MAGAZINES	04/02/2021	97.94		00/00	701-5691
BAKER & TAYLOR	1	Invoice	BOOKS/MAGAZINES	04/12/2021	237.78		00/00	701-5691
Total BAKER & TAYLOR (370):					721.28			
BAUER INSURANCE INC (410)								
BAUER INSURANCE INC	1	Invoice	E&O INSURANCE	04/02/2021	2,380.00		04/21	050-9720
Total BAUER INSURANCE INC (410):					2,380.00			
BEATRICE CONCRETE CO (440)								
BEATRICE CONCRETE CO	1	Invoice	2-3" SEITZ CLEAN ROCK	03/31/2021	51.00		00/00	401-5980
BEATRICE CONCRETE CO	1	Invoice	1-1/2 SCR N WEeping W	04/01/2021	409.36		00/00	401-5980
BEATRICE CONCRETE CO	1	Invoice	1-1/2 SCR N WEeping W	04/01/2021	429.42		00/00	401-5980
BEATRICE CONCRETE CO	1	Invoice	1-1/2 SCR N WEeping W	04/01/2021	411.06		00/00	401-5980
BEATRICE CONCRETE CO	1	Invoice	1-1/2 SCR N WEeping W	04/01/2021	411.40		00/00	401-5980
BEATRICE CONCRETE CO	1	Invoice	1-1/2 SCR N WEeping W	04/01/2021	385.22		00/00	401-5980
BEATRICE CONCRETE CO	1	Invoice	ROAD GRAVEL	04/01/2021	229.88		00/00	401-5980
BEATRICE CONCRETE CO	1	Invoice	2-3" SEITZ CLEAN ROCK	04/09/2021	97.58		00/00	401-5980
BEATRICE CONCRETE CO	1	Invoice	1-1/2 SCR N WEeping W	04/12/2021	99.28		00/00	401-5980

Name	Seq	Type	Description	Invoice Date	Total Cost	PO Number	Period	GL Account
Total BEATRICE CONCRETE CO (440):					2,524.20			
BELL, SETH (5688)								
BELL, SETH	1	Invoice	REFUND ACTIVITY FEE	04/01/2021	25.00		00/00	721-5901
Total BELL, SETH (5688):					25.00			
BLACK HILLS ENERGY (495)								
BLACK HILLS ENERGY	1	Invoice	UTILITY-1440 LINDEN	04/12/2021	118.85		00/00	001-7040
Total BLACK HILLS ENERGY (495):					118.85			
BLAKE BUILDERS LLC (5687)								
BLAKE BUILDERS LLC	1	Invoice	SEWER LINE REPAIR	04/02/2021	1,875.00		00/00	003-8101
Total BLAKE BUILDERS LLC (5687):					1,875.00			
BRANDING INC DBA AL'S JOHNS (575)								
BRANDING INC DBA AL'S JOHNS	1	Invoice	PORTABLE RESTROOM	03/31/2021	91.00		00/00	721-5350
Total BRANDING INC DBA AL'S JOHNS (575):					91.00			
BRANDT, GARRETT (5701)								
BRANDT, GARRETT	1	Invoice	REIMBURSE CDL LICENS	04/16/2021	45.50		00/00	401-9760
Total BRANDT, GARRETT (5701):					45.50			
BRETHOUWER, SETH (5614)								
BRETHOUWER, SETH	1	Invoice	REFUND ACTIVITY FEE	04/01/2021	25.00		00/00	721-5901
Total BRETHOUWER, SETH (5614):					25.00			
CASELLE, INC. (5609)								
CASELLE, INC.	1	Invoice	CONTRACT SUPPORT &	04/01/2021	831.76		00/00	001-2400
CASELLE, INC.	2	Invoice	CONTRACT SUPPORT &	04/01/2021	349.02		00/00	002-2400
CASELLE, INC.	3	Invoice	CONTRACT SUPPORT &	04/01/2021	272.21		00/00	003-2400
CASELLE, INC.	4	Invoice	CONTRACT SUPPORT &	04/01/2021	806.01		00/00	101-6050
Total CASELLE, INC. (5609):					2,259.00			

Name	Seq	Type	Description	Invoice Date	Total Cost	PO Number	Period	GL Account
CDW GOVERNMENT INC (750)								
CDW GOVERNMENT INC	1	Invoice	CANON MAINT CARTRID	03/31/2021	14.96		00/00	001-9920
CDW GOVERNMENT INC	2	Invoice	CANON MAINT CARTRID	03/31/2021	14.96		00/00	002-9920
CDW GOVERNMENT INC	3	Invoice	CANON MAINT CARTRID	03/31/2021	14.96		00/00	003-9920
CDW GOVERNMENT INC	4	Invoice	CANON MAINT CARTRID	03/31/2021	14.95		00/00	401-9920
Total CDW GOVERNMENT INC (750):					59.83			
CENGAGE LEARNING INC/GALE (1890)								
CENGAGE LEARNING INC/GALE	1	Invoice	BOOKS/MAGAZINES	02/11/2021	22.13		00/00	701-5691
Total CENGAGE LEARNING INC/GALE (1890):					22.13			
CITY HALL FUND (830)								
CITY HALL FUND	1	Invoice	DEPARTMENT OFFICE R	04/01/2021	548.00		00/00	001-9680
CITY HALL FUND	2	Invoice	DEPARTMENT OFFICE R	04/01/2021	412.00		00/00	002-9680
CITY HALL FUND	3	Invoice	DEPARTMENT OFFICE R	04/01/2021	265.00		00/00	003-9680
CITY HALL FUND	4	Invoice	DEPARTMENT OFFICE R	04/01/2021	187.50		00/00	101-9680
CITY HALL FUND	5	Invoice	DEPARTMENT OFFICE R	04/01/2021	150.00		00/00	401-9680
CITY HALL FUND	6	Invoice	DEPARTMENT OFFICE R	04/01/2021	37.50		00/00	721-9680
Total CITY HALL FUND (830):					1,600.00			
CITY HEALTH FUND (835)								
CITY HEALTH FUND	1	Invoice	HEALTH REIMBURSEME	04/01/2021	40.00		00/00	101-9620
CITY HEALTH FUND	2	Invoice	HEALTH REIMBURSEME	04/01/2021	47.00		00/00	201-9620
CITY HEALTH FUND	3	Invoice	HEALTH REIMBURSEME	04/01/2021	7.00		00/00	203-9620
CITY HEALTH FUND	4	Invoice	HEALTH REIMBURSEME	04/01/2021	40.00		00/00	401-9620
CITY HEALTH FUND	5	Invoice	HEALTH REIMBURSEME	04/01/2021	15.00		00/00	601-9620
CITY HEALTH FUND	6	Invoice	HEALTH REIMBURSEME	04/01/2021	59.00		00/00	701-9620
CITY HEALTH FUND	7	Invoice	HEALTH REIMBURSEME	04/01/2021	92.00		00/00	001-9620
CITY HEALTH FUND	8	Invoice	HEALTH REIMBURSEME	04/01/2021	40.00		00/00	002-9620
CITY HEALTH FUND	9	Invoice	HEALTH REIMBURSEME	04/01/2021	26.00		00/00	003-9620
Total CITY HEALTH FUND (835):					366.00			
CITY OF BEATRICE (840)								
CITY OF BEATRICE	1	Invoice	DISPATCH IT SERVICES	04/01/2021	5,000.00		00/00	202-9860
CITY OF BEATRICE	2	Invoice	DISPATCH SERVICES	04/01/2021	62,500.00		00/00	202-9750

Name	Seq	Type	Description	Invoice Date	Total Cost	PO Number	Period	GL Account
Total CITY OF BEATRICE (840):					67,500.00			
CITY REVENUE FUND (860)								
CITY REVENUE FUND	1	Invoice	FUEL OIL RECOVERY	04/01/2021	59.43		00/00	001-7090
CITY REVENUE FUND	2	Invoice	GAS PUMPS	04/01/2021	61.66		00/00	001-9670
CITY REVENUE FUND	3	Invoice	WATER (4)	04/01/2021	9,533.73		00/00	002-7100
CITY REVENUE FUND	4	Invoice	SEWER	04/01/2021	2,818.17		00/00	003-7530
CITY REVENUE FUND	5	Invoice	GENERAL (POLICE 1)	04/01/2021	690.07		00/00	201-5215
CITY REVENUE FUND	6	Invoice	GENERAL (POLICE 8)	04/01/2021	31.44		00/00	201-5610
CITY REVENUE FUND	7	Invoice	CITY HALL	04/01/2021	961.20		00/00	501-7530
CITY REVENUE FUND	8	Invoice	STREET & GRADE (6)	04/01/2021	4,152.87		00/00	401-7530
CITY REVENUE FUND	9	Invoice	STREET & GRADE (7)	04/01/2021	139.40		00/00	401-5890
CITY REVENUE FUND	10	Invoice	FIRE MAINT.	04/01/2021	2,231.30		00/00	301-7530
CITY REVENUE FUND	11	Invoice	CEMETERY	04/01/2021	137.38		00/00	601-7530
CITY REVENUE FUND	12	Invoice	SAN. LANDFILL	04/01/2021	62.88		00/00	511-7530
CITY REVENUE FUND	13	Invoice	LIBRARY	04/01/2021	1,209.88		00/00	701-7530
CITY REVENUE FUND	14	Invoice	PARK & REC	04/01/2021	1,918.45		00/00	521-7530
CITY REVENUE FUND	15	Invoice	THEATRE	04/01/2021	84.87		00/00	810-5210
CITY REVENUE FUND	16	Invoice	SWIMMING POOL	04/01/2021	.00		00/00	522-7530
CITY REVENUE FUND	17	Invoice	COMM. DEVELOP.	04/01/2021	65.24		00/00	101-6201
CITY REVENUE FUND	1	Invoice	ELECTRIC	04/01/2021	69.88		00/00	001-7060
CITY REVENUE FUND	2	Invoice	POLICE	04/01/2021	35.03		00/00	201-5215
CITY REVENUE FUND	3	Invoice	CITY HALL	04/01/2021	82.37		00/00	501-7530
CITY REVENUE FUND	4	Invoice	STREET & GRADE	04/01/2021	35.91		00/00	401-7530
CITY REVENUE FUND	5	Invoice	FIRE MAINT.	04/01/2021	36.78		00/00	301-7530
CITY REVENUE FUND	6	Invoice	LIBRARY	04/01/2021	.00		00/00	701-7530
CITY REVENUE FUND	7	Invoice	PARK BLDG	04/01/2021	.00		00/00	721-7530
CITY REVENUE FUND	8	Invoice	SWIMMING POOL	04/01/2021	.00		00/00	522-7530
CITY REVENUE FUND	9	Invoice	THEATRE	04/01/2021	.00		00/00	810-5210
CITY REVENUE FUND	10	Invoice	PARK & REC	04/01/2021	135.12		00/00	521-7530
CITY REVENUE FUND	1	Invoice	ELECTRIC	04/01/2021	107.22		00/00	001-7060
CITY REVENUE FUND	2	Invoice	SEWER REV	04/01/2021	748.72		00/00	003-7530
CITY REVENUE FUND	3	Invoice	POLICE	04/01/2021	30.03		00/00	201-5215
CITY REVENUE FUND	4	Invoice	CITY HALL	04/01/2021	74.13		00/00	501-7530
CITY REVENUE FUND	5	Invoice	STREET & GRADE	04/01/2021	55.64		00/00	401-7530
CITY REVENUE FUND	6	Invoice	FIRE MAINT.	04/01/2021	60.80		00/00	301-7530
CITY REVENUE FUND	7	Invoice	CEMETERY	04/01/2021	.00		00/00	601-7530
CITY REVENUE FUND	8	Invoice	LANDFILL	04/01/2021	.00		00/00	511-7530
CITY REVENUE FUND	9	Invoice	LIBRARY	04/01/2021	204.61		00/00	701-7530
CITY REVENUE FUND	10	Invoice	PARKS & REC	04/01/2021	369.90		00/00	521-7530

Name	Seq	Type	Description	Invoice Date	Total Cost	PO Number	Period	GL Account
CITY REVENUE FUND	11	Invoice	THEATRE	04/01/2021	.00		00/00	810-5210
CITY REVENUE FUND	12	Invoice	SWIMMING POOL	04/01/2021	.00		00/00	522-7530
CITY REVENUE FUND	13	Invoice	PARK BLDG	04/01/2021	.00		00/00	721-7530
CITY REVENUE FUND	1	Invoice	WATER	04/01/2021	18.75		04/21	050-7530
CITY REVENUE FUND	1	Invoice	FRANCHISE FEE	04/07/2021	1,084.80		00/00	511-4012
CITY REVENUE FUND	1	Invoice	DUG GRAVE-BERNIECE	04/12/2021	60.00		00/00	601-5340
Total CITY REVENUE FUND (860):					27,367.66			
CITY TAX FUND (865)								
CITY TAX FUND	1	Invoice	ELECTRIC SURPLUS & F	04/01/2021	29,167.00		00/00	001-9960
CITY TAX FUND	2	Invoice	ELECTRIC SURPLUS & F	04/01/2021	10,000.00		00/00	001-9965
CITY TAX FUND	1	Invoice	LIBRARY BOND PAYMEN	04/01/2021	21,000.00		00/00	150-1015
Total CITY TAX FUND (865):					60,167.00			
CRETE ACE HARDWARE (1060)								
CRETE ACE HARDWARE	1	Invoice	SUPPLIES	03/04/2021	10.63		04/21	050-5330
CRETE ACE HARDWARE	1	Invoice	SUPPLIES	03/30/2021	2.50		04/21	050-5330
CRETE ACE HARDWARE	1	Invoice	CITY HALL CONST	03/02/2021	52.50		00/00	531-6482
CRETE ACE HARDWARE	1	Invoice	CITY HALL CONST	03/03/2021	2.75		00/00	531-6482
CRETE ACE HARDWARE	1	Invoice	BROOM/HANDLE	03/04/2021	21.69		00/00	601-8500
CRETE ACE HARDWARE	1	Invoice	OIL/FUEL FILTERS	03/05/2021	31.98		00/00	401-5771
CRETE ACE HARDWARE	2	Invoice	HYDRAULIC FLUID	03/05/2021	13.99		00/00	401-5801
CRETE ACE HARDWARE	1	Invoice	MOWER BLADE	03/09/2021	71.97		00/00	003-7220
CRETE ACE HARDWARE	1	Invoice	ZIP TIES	03/10/2021	16.28		00/00	521-5332
CRETE ACE HARDWARE	1	Invoice	WEED EATER	03/10/2021	359.99		00/00	601-8500
CRETE ACE HARDWARE	1	Invoice	SCREWS	03/11/2021	37.71		00/00	401-6020
CRETE ACE HARDWARE	1	Invoice	TAPE MEASURE, BROOM	03/12/2021	41.37		00/00	401-6020
CRETE ACE HARDWARE	1	Invoice	SLUDGE PROCESS	03/17/2021	91.81		00/00	003-7031
CRETE ACE HARDWARE	1	Invoice	GE96" TUBE	03/17/2021	18.38		00/00	401-5330
CRETE ACE HARDWARE	2	Invoice	GRACO TSL	03/17/2021	11.95		00/00	401-6010
CRETE ACE HARDWARE	1	Invoice	SCREWS, PLIERS, CUT	03/22/2021	31.86		00/00	401-6020
CRETE ACE HARDWARE	1	Invoice	TOILET PAPER	03/22/2021	170.16		00/00	521-5332
CRETE ACE HARDWARE	1	Invoice	DOOR STOP	03/25/2021	7.90		00/00	201-5329
CRETE ACE HARDWARE	1	Invoice	CITY HALL CONST	03/25/2021	6.60		00/00	531-6482
CRETE ACE HARDWARE	1	Invoice	SLEDGE HAMMER	03/26/2021	37.71		00/00	401-6020
CRETE ACE HARDWARE	1	Invoice	JANITORIAL SUPPLIES	03/29/2021	7.35		00/00	401-5541
CRETE ACE HARDWARE	2	Invoice	GREASE GUN	03/29/2021	4.59		00/00	401-6020
CRETE ACE HARDWARE	3	Invoice	SEALANT	03/29/2021	7.90		00/00	401-5880
CRETE ACE HARDWARE	1	Invoice	TV MOUNT-COUNCIL CH	03/30/2021	22.98		00/00	501-6020

Name	Seq	Type	Description	Invoice Date	Total Cost	PO Number	Period	GL Account
CRETE ACE HARDWARE	1	Invoice	CUTWHEEL	03/08/2021	13.32		00/00	002-7080
CRETE ACE HARDWARE	1	Invoice	GAS TREATMENT-CHAIN	03/12/2021	25.79		00/00	001-8500
CRETE ACE HARDWARE	1	Invoice	NUTS/BOLTS	03/24/2021	11.99		00/00	002-8031
CRETE ACE HARDWARE	1	Invoice	PLIERS	03/30/2021	15.47		00/00	002-7080
CRETE ACE HARDWARE	1	Invoice	BLDG/GRND MAINT	03/08/2021	3.38		00/00	301-5330
CRETE ACE HARDWARE	1	Invoice	BLDG/GRND MAINT	03/10/2021	31.99		00/00	301-5330
CRETE ACE HARDWARE	1	Invoice	BLDG/GRND MAINT	03/16/2021	122.27		00/00	301-5330
Total CRETE ACE HARDWARE (1060):					1,306.76			
CRETE AREA MEDICAL CENTER (1070)								
CRETE AREA MEDICAL CENTER	1	Invoice	AMBULANCE LAUNDRY	04/01/2021	35.00		00/00	302-8500
Total CRETE AREA MEDICAL CENTER (1070):					35.00			
CRETE FOODMART (1095)								
CRETE FOODMART	1	Invoice	LAB SUPPLIES	04/02/2021	25.00		00/00	003-7282
CRETE FOODMART	1	Invoice	REFUND LAB SUPPLIES	04/02/2021	2.50-		00/00	003-7282
Total CRETE FOODMART (1095):					22.50			
CRETE LUMBER & FARM SUPPLY CO (1110)								
CRETE LUMBER & FARM SUPPLY CO	1	Invoice	STORM SEWER REPAIR	03/24/2021	103.18		00/00	401-5880
Total CRETE LUMBER & FARM SUPPLY CO (1110):					103.18			
CRETE VETERINARY CLINIC (1140)								
CRETE VETERINARY CLINIC	1	Invoice	BOARD - DOG	03/10/2021	87.00		00/00	203-5345
CRETE VETERINARY CLINIC	1	Invoice	BOARD - DOG	03/19/2021	36.24		00/00	203-5345
CRETE VETERINARY CLINIC	1	Invoice	BOARD - DOG	03/23/2021	53.98		00/00	203-5345
CRETE VETERINARY CLINIC	1	Invoice	BOARD - DOG	03/29/2021	17.74		00/00	203-5345
Total CRETE VETERINARY CLINIC (1140):					194.96			
CULLIGAN WATER SERVICE (1160)								
CULLIGAN WATER SERVICE	1	Invoice	SOFTNER SALT	03/08/2021	45.00		04/21	050-7530
CULLIGAN WATER SERVICE	1	Invoice	WATER COOLER RENTA	03/31/2021	51.25		00/00	701-9900
Total CULLIGAN WATER SERVICE (1160):					96.25			

Name	Seq	Type	Description	Invoice Date	Total Cost	PO Number	Period	GL Account
DEPT. OF ENERGY W.A.P.A. (1250)								
DEPT. OF ENERGY W.A.P.A.	1	Invoice	PURCHASED POWER W	04/11/2021	21,122.19		00/00	001-7240
Total DEPT. OF ENERGY W.A.P.A. (1250):					21,122.19			
DJ WELDING (1330)								
DJ WELDING	1	Invoice	PLATES FOR COUNTERT	03/31/2021	141.00		00/00	531-6482
Total DJ WELDING (1330):					141.00			
EAKES OFFICE SOLUTIONS (1475)								
EAKES OFFICE SOLUTIONS	1	Invoice	DISCONNECT NOTICES	04/09/2021	229.76		00/00	001-9900
EAKES OFFICE SOLUTIONS	2	Invoice	DISCONNECT NOTICES	04/09/2021	229.75		00/00	002-9900
EAKES OFFICE SOLUTIONS	3	Invoice	DISCONNECT NOTICES	04/09/2021	206.51		00/00	003-9900
EAKES OFFICE SOLUTIONS	1	Invoice	OFFICE SUPPLIES	04/08/2021	43.39		00/00	101-9900
EAKES OFFICE SOLUTIONS	1	Invoice	OFFICE SUPPLIES	04/08/2021	46.43		00/00	101-9900
EAKES OFFICE SOLUTIONS	1	Invoice	OFFICE SUPPLIES	04/09/2021	14.98		00/00	101-9900
EAKES OFFICE SOLUTIONS	2	Invoice	OFFICE SUPPLIES	04/09/2021	14.98		00/00	201-9900
EAKES OFFICE SOLUTIONS	3	Invoice	OFFICE SUPPLIES	04/09/2021	59.94		00/00	001-9900
EAKES OFFICE SOLUTIONS	4	Invoice	OFFICE SUPPLIES	04/09/2021	14.98		00/00	002-9900
EAKES OFFICE SOLUTIONS	5	Invoice	OFFICE SUPPLIES	04/09/2021	14.98		00/00	003-9900
EAKES OFFICE SOLUTIONS	6	Invoice	OFFICE SUPPLIES	04/09/2021	14.98		00/00	401-9900
EAKES OFFICE SOLUTIONS	7	Invoice	OFFICE SUPPLIES	04/09/2021	14.98		00/00	721-9900
EAKES OFFICE SOLUTIONS	1	Invoice	OFFICE SUPPLIES	04/15/2021	37.99		00/00	301-9900
EAKES OFFICE SOLUTIONS	2	Invoice	OFFICE SUPPLIES	04/15/2021	37.99		00/00	101-9900
EAKES OFFICE SOLUTIONS	1	Invoice	JANITORIAL SUPPLIES	04/15/2021	80.14		00/00	701-5541
Total EAKES OFFICE SOLUTIONS (1475):					1,061.78			
ELEVATE AIR SERVICE LLC (1525)								
ELEVATE AIR SERVICE LLC	1	Invoice	OFFICE REMODELING	04/07/2021	757.67		04/21	050-5330
Total ELEVATE AIR SERVICE LLC (1525):					757.67			
EMERGENCY MEDICAL PRODUCTS (1570)								
EMERGENCY MEDICAL PRODUCTS	1	Invoice	MEDICAL SUPPLIES	04/08/2021	417.63		00/00	302-5341
Total EMERGENCY MEDICAL PRODUCTS (1570):					417.63			
EXECUTIVE ANSWERING SERVICE (1670)								
EXECUTIVE ANSWERING SERVICE	1	Invoice	ANSWERING SERVICE	04/15/2021	11.04		00/00	203-9980

Name	Seq	Type	Description	Invoice Date	Total Cost	PO Number	Period	GL Account
EXECUTIVE ANSWERING SERVICE	2	Invoice	ANSWERING SERVICE	04/15/2021	13.80		00/00	401-9980
EXECUTIVE ANSWERING SERVICE	3	Invoice	ANSWERING SERVICE	04/15/2021	.55		00/00	601-9980
EXECUTIVE ANSWERING SERVICE	4	Invoice	ANSWERING SERVICE	04/15/2021	.55		00/00	511-9980
EXECUTIVE ANSWERING SERVICE	5	Invoice	ANSWERING SERVICE	04/15/2021	1.66		00/00	521-9980
EXECUTIVE ANSWERING SERVICE	6	Invoice	ANSWERING SERVICE	04/15/2021	55.20		00/00	001-9980
EXECUTIVE ANSWERING SERVICE	7	Invoice	ANSWERING SERVICE	04/15/2021	13.80		00/00	002-9980
EXECUTIVE ANSWERING SERVICE	8	Invoice	ANSWERING SERVICE	04/15/2021	13.80		00/00	003-9980
Total EXECUTIVE ANSWERING SERVICE (1670):					110.40			
FIRST NATIONAL BANK OF OMAHA (1770)								
FIRST NATIONAL BANK OF OMAHA	1	Invoice	STEVE CC, MIDWAYUSA	04/05/2021	122.70		00/00	531-6477
FIRST NATIONAL BANK OF OMAHA	2	Invoice	STEVE CC, LINKEDIN 640	04/05/2021	42.99		00/00	201-9760
FIRST NATIONAL BANK OF OMAHA	3	Invoice	STEVE CC, AMAZON XX-	04/05/2021	9.30		00/00	531-6477
FIRST NATIONAL BANK OF OMAHA	4	Invoice	STEVE CC, AMAZON XX-	04/05/2021	39.98		00/00	531-6477
FIRST NATIONAL BANK OF OMAHA	5	Invoice	STEVE CC, AMAZON XX-	04/05/2021	246.99		00/00	531-6477
FIRST NATIONAL BANK OF OMAHA	6	Invoice	STEVE CC, WALMART 07	04/05/2021	99.94		00/00	201-5660
FIRST NATIONAL BANK OF OMAHA	7	Invoice	STEVE CC, AMAZON XX-	04/05/2021	46.47		00/00	531-6477
FIRST NATIONAL BANK OF OMAHA	8	Invoice	STEVE CC, LATE FEE & I	04/05/2021	54.79		00/00	201-8500
FIRST NATIONAL BANK OF OMAHA	1	Invoice	YOUNG CC, CONSOLIDA	03/05/2021	3.94		00/00	201-9760
FIRST NATIONAL BANK OF OMAHA	1	Invoice	YOUNG CC, LLRMI 5498	04/05/2021	79.00		00/00	201-9760
FIRST NATIONAL BANK OF OMAHA	2	Invoice	YOUNG CC, INTEREST	04/05/2021	1.75		00/00	201-8500
Total FIRST NATIONAL BANK OF OMAHA (1770):					747.85			
HAVLAT, DAWN (5689)								
HAVLAT, DAWN	1	Invoice	REFUND ACTIVITY FEE	04/01/2021	15.00		00/00	721-5901
Total HAVLAT, DAWN (5689):					15.00			
HUSKER ELECTRIC SUPPLY CO (2285)								
HUSKER ELECTRIC SUPPLY CO	1	Invoice	REPLACEMENT ELEMEN	03/31/2021	726.67	1124	00/00	001-7220
HUSKER ELECTRIC SUPPLY CO	1	Invoice	WIRE, TRIPLEX, 4/0 - 2/0	04/14/2021	4,434.38	1130	00/00	001-1500
HUSKER ELECTRIC SUPPLY CO	2	Invoice	WIRE, TRIPLEX, 500 MC	04/14/2021	3,743.15	1130	00/00	001-1500
Total HUSKER ELECTRIC SUPPLY CO (2285):					8,904.20			
INLAND TRUCK PARTS CO (2335)								
INLAND TRUCK PARTS CO	1	Invoice	E-5 BRAKE VALVE	04/14/2021	118.01		00/00	003-7220

Name	Seq	Type	Description	Invoice Date	Total Cost	PO Number	Period	GL Account
Total INLAND TRUCK PARTS CO (2335):					118.01			
JAY'S OIL CO. (2405)								
JAY'S OIL CO.	1	Invoice	TIRE REPAIR	03/01/2021	25.00		00/00	002-8460
JAY'S OIL CO.	1	Invoice	TIRE REPAIR-UNIT 2	04/08/2021	25.00		00/00	201-5810
Total JAY'S OIL CO. (2405):					50.00			
JONES AUTOMOTIVE (2475)								
JONES AUTOMOTIVE	1	Invoice	FULL VEHICLE STRIP	02/25/2021	760.00		00/00	531-6420
Total JONES AUTOMOTIVE (2475):					760.00			
KEN'S USAVE PHARMACY (2570)								
KEN'S USAVE PHARMACY	1	Invoice	MEDICAL SUPPLIES	03/11/2021	7.89		00/00	302-5341
Total KEN'S USAVE PHARMACY (2570):					7.89			
KUSS, ROD (5690)								
KUSS, ROD	1	Invoice	REIMBURSE FOR TORD	04/13/2021	91.32		00/00	001-8020
Total KUSS, ROD (5690):					91.32			
LANGUAGELINC INTERPRETATION SERVICES/ (5685)								
LANGUAGELINC INTERPRETATION SERVICES/	1	Invoice	INTERPRETATION OVER	02/10/2021	21.00		00/00	201-5382
Total LANGUAGELINC INTERPRETATION SERVICES/ (5685):					21.00			
LIBRARY FURNITURE INTERNATIONAL INC (5622)								
LIBRARY FURNITURE INTERNATIONAL INC	1	Invoice	SHELVING	01/22/2021	1,126.00		00/00	532-6482
Total LIBRARY FURNITURE INTERNATIONAL INC (5622):					1,126.00			
MANHATTAN LIFE ASSURANCE CO (2960)								
MANHATTAN LIFE ASSURANCE CO	1	Invoice	ELECTIVE COVERAGE	04/01/2021	7.21		04/21	201-9620
Total MANHATTAN LIFE ASSURANCE CO (2960):					7.21			
MAX I WALKER UNIFORM & APPAREL (3035)								
MAX I WALKER UNIFORM & APPAREL	1	Invoice	UNIFORMS	04/07/2021	60.17		00/00	003-9640

Name	Seq	Type	Description	Invoice Date	Total Cost	PO Number	Period	GL Account
MAX I WALKER UNIFORM & APPAREL	1	Invoice	UNIFORMS	04/14/2021	60.17		00/00	003-9640
Total MAX I WALKER UNIFORM & APPAREL (3035):					120.34			
MCI VERIZON (3055)								
MCI VERIZON	1	Invoice	TOLL FREE LINE	04/07/2021	.00		00/00	
MCI VERIZON	2	Invoice	TOLL FREE LINE	04/07/2021	12.00		00/00	101-7530
MCI VERIZON	3	Invoice	TOLL FREE LINE	04/07/2021	12.00		00/00	201-5220
MCI VERIZON	4	Invoice	TOLL FREE LINE	04/07/2021	12.00		00/00	301-7530
MCI VERIZON	5	Invoice	TOLL FREE LINE	04/07/2021	12.00		00/00	721-7530
MCI VERIZON	6	Invoice	TOLL FREE LINE	04/07/2021	18.31		00/00	001-9660
Total MCI VERIZON (3055):					66.31			
METAL DOORS & HARDWARE CO (5700)								
METAL DOORS & HARDWARE CO	1	Invoice	ELECTRONIC KEY PAD L	04/15/2021	690.40		00/00	201-5329
Total METAL DOORS & HARDWARE CO (5700):					690.40			
MIDWEST ALARM SERVICES (3175)								
MIDWEST ALARM SERVICES	1	Invoice	ALARM MONITORING 210	04/08/2021	85.50		00/00	301-5330
Total MIDWEST ALARM SERVICES (3175):					85.50			
MIDWEST LABORATORIES INC (3195)								
MIDWEST LABORATORIES INC	1	Invoice	LABS	04/05/2021	1,720.00		00/00	003-7282
Total MIDWEST LABORATORIES INC (3195):					1,720.00			
MIDWEST PETROLEUM EQUIPMENT (3205)								
MIDWEST PETROLEUM EQUIPMENT	1	Invoice	PCB COMMUNICATION A	03/31/2021	1,063.36	1129	00/00	001-7210
MIDWEST PETROLEUM EQUIPMENT	2	Invoice	TRIP CHARGE	03/31/2021	25.00	1129	00/00	001-7210
MIDWEST PETROLEUM EQUIPMENT	3	Invoice	SERVICE LABOR	03/31/2021	380.00	1129	00/00	001-7210
Total MIDWEST PETROLEUM EQUIPMENT (3205):					1,468.36			
MUTUAL OF OMAHA (3330)								
MUTUAL OF OMAHA	1	Invoice	ADDITIONAL LIFE AND DI	04/01/2021	154.95		04/21	101-9620
MUTUAL OF OMAHA	2	Invoice	ADDITIONAL LIFE AND DI	04/01/2021	230.75		04/21	201-9620
MUTUAL OF OMAHA	3	Invoice	ADDITIONAL LIFE AND DI	04/01/2021	107.00		04/21	401-9620
MUTUAL OF OMAHA	4	Invoice	ADDITIONAL LIFE AND DI	04/01/2021	75.39		04/21	301-9620

Name	Seq	Type	Description	Invoice Date	Total Cost	PO Number	Period	GL Account
MUTUAL OF OMAHA	5	Invoice	ADDITIONAL LIFE AND DI	04/01/2021	91.71		04/21	701-9620
MUTUAL OF OMAHA	6	Invoice	ADDITIONAL LIFE AND DI	04/01/2021	30.57		04/21	521-9620
MUTUAL OF OMAHA	7	Invoice	ADDITIONAL LIFE AND DI	04/01/2021	15.29		04/21	721-9620
MUTUAL OF OMAHA	8	Invoice	ADDITIONAL LIFE AND DI	04/01/2021	166.05		04/21	001-9620
MUTUAL OF OMAHA	9	Invoice	ADDITIONAL LIFE AND DI	04/01/2021	76.43		04/21	002-9620
MUTUAL OF OMAHA	10	Invoice	ADDITIONAL LIFE AND DI	04/01/2021	61.14		04/21	003-9620
MUTUAL OF OMAHA	11	Invoice	ADDITIONAL LIFE AND DI	04/01/2021	.00		00/00	101-9620
MUTUAL OF OMAHA	12	Invoice	ADDITIONAL LIFE AND DI	04/01/2021	.00		00/00	201-9620
MUTUAL OF OMAHA	13	Invoice	ADDITIONAL LIFE AND DI	04/01/2021	.00		00/00	401-9620
MUTUAL OF OMAHA	14	Invoice	ADDITIONAL LIFE AND DI	04/01/2021	.00		00/00	701-9620
MUTUAL OF OMAHA	15	Invoice	ADDITIONAL LIFE AND DI	04/01/2021	.00		00/00	521-9620
MUTUAL OF OMAHA	16	Invoice	ADDITIONAL LIFE AND DI	04/01/2021	.00		00/00	721-9620
MUTUAL OF OMAHA	17	Invoice	ADDITIONAL LIFE AND DI	04/01/2021	.00		00/00	001-9620
MUTUAL OF OMAHA	18	Invoice	ADDITIONAL LIFE AND DI	04/01/2021	.00		00/00	002-9620
MUTUAL OF OMAHA	19	Invoice	ADDITIONAL LIFE AND DI	04/01/2021	.00		00/00	003-9620
Total MUTUAL OF OMAHA (3330):					1,009.28			
NAPA AUTO PARTS (3345)								
NAPA AUTO PARTS	1	Invoice	VEHICLE EXPENSE	03/24/2021	163.32		00/00	001-8460
NAPA AUTO PARTS	1	Invoice	VEHICLE EXPENSE	03/26/2021	21.39		00/00	001-8460
NAPA AUTO PARTS	1	Invoice	V-BELT, REMAN ALTERN	04/06/2021	144.03		00/00	001-8460
NAPA AUTO PARTS	1	Invoice	VEHICLE REPAIR	03/07/2021	279.00		00/00	301-5791
NAPA AUTO PARTS	1	Invoice	VEHICLE REPAIR	03/08/2021	24.36		00/00	301-5791
NAPA AUTO PARTS	1	Invoice	VEHICLE REPAIR	03/23/2021	12.68		00/00	301-5791
Total NAPA AUTO PARTS (3345):					644.78			
NE PUBLIC HEALTH ENVIRONMENTAL LABORATOR (3480)								
NE PUBLIC HEALTH ENVIRONMENTAL LABORATO	1	Invoice	LABS	04/13/2021	104.00		00/00	002-7281
Total NE PUBLIC HEALTH ENVIRONMENTAL LABORATOR (3480):					104.00			
NEBRASKA MUNICIPAL POWER POOL (3555)								
NEBRASKA MUNICIPAL POWER POOL	1	Invoice	MEMBERSHIP DUES	04/01/2021	3,294.40		00/00	001-9780
NEBRASKA MUNICIPAL POWER POOL	1	Invoice	COST OF SERVICE STUD	04/14/2021	3,165.00		00/00	001-9840
Total NEBRASKA MUNICIPAL POWER POOL (3555):					6,459.40			
NEBRASKA STATE PATROL (5691)								
NEBRASKA STATE PATROL	1	Invoice	2021 MACH LICENSE	03/24/2021	288.00		00/00	201-9860

Name	Seq	Type	Description	Invoice Date	Total Cost	PO Number	Period	GL Account
Total NEBRASKA STATE PATROL (5691):					288.00			
NEBRASKALAND TIRE INC (5636)								
NEBRASKALAND TIRE INC	1	Invoice	USED TIRE	03/17/2021	64.49		00/00	521-5810
NEBRASKALAND TIRE INC	1	Invoice	'76 GRADER-TIRE REPAI	04/08/2021	86.83		00/00	401-5810
NEBRASKALAND TIRE INC	1	Invoice	'75 GRADER-TIRE REPAI	04/09/2021	86.83		00/00	401-5968
Total NEBRASKALAND TIRE INC (5636):					238.15			
NERUD, BONNIE (5692)								
NERUD, BONNIE	1	Invoice	REFUND ACTIVITY FEE	04/01/2021	25.00		00/00	721-5901
Total NERUD, BONNIE (5692):					25.00			
NORRIS PUBLIC POWER DISTRICT (3685)								
NORRIS PUBLIC POWER DISTRICT	1	Invoice	ELECTRICITY	04/01/2021	771.13		04/21	050-7530
NORRIS PUBLIC POWER DISTRICT	1	Invoice	ELECTRICITY	04/02/2021	8,449.67		00/00	003-7530
NORRIS PUBLIC POWER DISTRICT	1	Invoice	UTILITIES	04/02/2021	10.09		00/00	521-7530
Total NORRIS PUBLIC POWER DISTRICT (3685):					9,230.89			
OCLC INC (3745)								
OCLC INC	1	Invoice	STATE GRANT EXPENSE	04/01/2021	171.77		00/00	702-5700
Total OCLC INC (3745):					171.77			
OLSSON (3775)								
OLSSON	1	Invoice	FUEL SYSTEM #2	02/24/2021	21,200.00		04/21	050-2410
OLSSON	1	Invoice	#015-08260 CRETE CORE	02/11/2021	576.88		00/00	003-9840
Total OLSSON (3775):					21,776.88			
ONE CALL CONCEPTS INC (3810)								
ONE CALL CONCEPTS INC	1	Invoice	LOCATING SERVICE FEE	03/31/2021	47.46		00/00	001-9730
ONE CALL CONCEPTS INC	2	Invoice	LOCATING SERVICE FEE	03/31/2021	47.45		00/00	002-9730
Total ONE CALL CONCEPTS INC (3810):					94.91			
PAPER TIGER SHREDDING (3905)								
PAPER TIGER SHREDDING	1	Invoice	PAPER SHREDDING	03/31/2021	30.00		00/00	201-5329

Name	Seq	Type	Description	Invoice Date	Total Cost	PO Number	Period	GL Account
Total PAPER TIGER SHREDDING (3905):					30.00			
QUADIENT FINANCE USA INC (5591)								
QUADIENT FINANCE USA INC	1	Invoice	POSTAGE	04/01/2021	100.00		00/00	101-9650
QUADIENT FINANCE USA INC	2	Invoice	POSTAGE	04/01/2021	25.00		00/00	401-9650
QUADIENT FINANCE USA INC	3	Invoice	POSTAGE	04/01/2021	75.00		00/00	701-9650
QUADIENT FINANCE USA INC	4	Invoice	POSTAGE	04/01/2021	75.00		00/00	721-9650
QUADIENT FINANCE USA INC	5	Invoice	POSTAGE	04/01/2021	125.00		00/00	001-9650
QUADIENT FINANCE USA INC	6	Invoice	POSTAGE	04/01/2021	50.00		00/00	002-9650
QUADIENT FINANCE USA INC	7	Invoice	POSTAGE	04/01/2021	50.00		00/00	003-9650
Total QUADIENT FINANCE USA INC (5591):					500.00			
QUADIENT LEASING USA INC (4100)								
QUADIENT LEASING USA INC	1	Invoice	POSTAGE LEASE PMT	03/28/2021	379.38		00/00	701-9740
Total QUADIENT LEASING USA INC (4100):					379.38			
QUICK MED CLAIMS (4125)								
QUICK MED CLAIMS	1	Invoice	OUTSIDE SERVICES (AC	03/31/2021	8,029.08		00/00	302-5340
Total QUICK MED CLAIMS (4125):					8,029.08			
QUILL CORP. (4130)								
QUILL CORP.	1	Invoice	JANITORIAL SUPPLIES	03/29/2021	46.29		00/00	701-5541
Total QUILL CORP. (4130):					46.29			
RAILROAD MANAGEMENT CO III LLC (4155)								
RAILROAD MANAGEMENT CO III LLC	1	Invoice	LICENSE #303906	03/30/2021	284.85		00/00	001-9690
RAILROAD MANAGEMENT CO III LLC	1	Invoice	LICENSE #304034	03/30/2021	284.85		00/00	001-9690
Total RAILROAD MANAGEMENT CO III LLC (4155):					569.70			
RISCHE, MARY (5693)								
RISCHE, MARY	1	Invoice	REFUND ACTIVITY FEE	04/01/2021	25.00		00/00	721-5901
Total RISCHE, MARY (5693):					25.00			

Name	Seq	Type	Description	Invoice Date	Total Cost	PO Number	Period	GL Account
ROLD, MARIE (5694)								
ROLD, MARIE	1	Invoice	REFUND ACTIVITY FEE	04/01/2021	25.00		00/00	721-5901
Total ROLD, MARIE (5694):					25.00			
ROOT, DEREK (5695)								
ROOT, DEREK	1	Invoice	REFUND ACTIVITY FEE	04/01/2021	25.00		00/00	721-5901
Total ROOT, DEREK (5695):					25.00			
SACK LUMBER CO (4385)								
SACK LUMBER CO	1	Invoice	SPRAY TEXTURE	04/02/2021	27.93		00/00	531-6482
Total SACK LUMBER CO (4385):					27.93			
SAPP BROS PETROLEUM (4505)								
SAPP BROS PETROLEUM	1	Invoice	AIR METHODS PROPANE	03/09/2021	346.50		04/21	050-4215
SAPP BROS PETROLEUM	1	Invoice	SRE PROPANE	03/09/2021	247.83		04/21	050-7530
SAPP BROS PETROLEUM	1	Invoice	FUEL-ACCT #742498	03/31/2021	537.97		00/00	301-5800
Total SAPP BROS PETROLEUM (4505):					1,132.30			
SCHINDLER ELEVATOR CORP (4530)								
SCHINDLER ELEVATOR CORP	1	Invoice	INSPECTION SERVICE	02/01/2021	166.11		00/00	201-5329
Total SCHINDLER ELEVATOR CORP (4530):					166.11			
SEWARD COUNTY INDEPENDENT (4590)								
SEWARD COUNTY INDEPENDENT	1	Invoice	BID NOTICE	04/07/2021	241.83		04/21	050-5390
SEWARD COUNTY INDEPENDENT	1	Invoice	MEETING NOTICE	03/31/2021	11.05		04/21	050-5390
SEWARD COUNTY INDEPENDENT	1	Invoice	MEETING-LIBRARY	03/31/2021	10.23		00/00	701-5390
SEWARD COUNTY INDEPENDENT	1	Invoice	NOTICE-APPRAISAL SER	03/31/2021	129.17		00/00	551-5007
SEWARD COUNTY INDEPENDENT	1	Invoice	MEETING-CITY COUNCIL	03/31/2021	10.23		00/00	101-5390
SEWARD COUNTY INDEPENDENT	1	Invoice	OFFICE SUPPLIES	03/31/2021	27.00		00/00	701-9900
SEWARD COUNTY INDEPENDENT	1	Invoice	HEARING 4-20-21	04/07/2021	9.82		00/00	101-5390
SEWARD COUNTY INDEPENDENT	1	Invoice	LIQUOR LICENSES	04/07/2021	9.82		00/00	101-4904
SEWARD COUNTY INDEPENDENT	1	Invoice	MEETING-CITY COUNCIL	04/07/2021	10.23		00/00	101-5390
SEWARD COUNTY INDEPENDENT	1	Invoice	MEETING-FIRE	03/31/2021	9.82		00/00	301-5390
SEWARD COUNTY INDEPENDENT	1	Invoice	MINUTES 4-6-21	04/14/2021	69.95		00/00	101-5390
SEWARD COUNTY INDEPENDENT	1	Invoice	MEETING-PLAN COMM	04/14/2021	10.23		00/00	101-5480
SEWARD COUNTY INDEPENDENT	1	Invoice	MEETING-CEMETERY	04/14/2021	11.05		00/00	601-5390

Name	Seq	Type	Description	Invoice Date	Total Cost	PO Number	Period	GL Account
Total SEWARD COUNTY INDEPENDENT (4590):					560.43			
SID DILLON FORD (4635)								
SID DILLON FORD	1	Invoice	OIL CHANGE UNIT 3	04/07/2021	53.30		00/00	201-5801
SID DILLON FORD	1	Invoice	OIL CHANGE UNIT 6	04/09/2021	36.60		00/00	201-5801
Total SID DILLON FORD (4635):					89.90			
SIEDHOFF BODY SHOP (4640)								
SIEDHOFF BODY SHOP	1	Invoice	2021-1730 TOWING	04/12/2021	85.00		00/00	201-5812
Total SIEDHOFF BODY SHOP (4640):					85.00			
SLAMA, CODI (5696)								
SLAMA, CODI	1	Invoice	REFUND ACTIVITY FEE	04/01/2021	25.00		00/00	721-5901
Total SLAMA, CODI (5696):					25.00			
SPECTRUM (4730)								
SPECTRUM	1	Invoice	INTERNET	04/01/2021	64.69		00/00	101-7530
SPECTRUM	2	Invoice	INTERNET	04/01/2021	46.88		00/00	201-6050
SPECTRUM	3	Invoice	TV	04/01/2021	1.12		00/00	101-7530
SPECTRUM	4	Invoice	INTERNET	04/01/2021	16.10		00/00	301-7530
SPECTRUM	5	Invoice	INTERNET	04/01/2021	35.38		00/00	701-7530
SPECTRUM	6	Invoice	TV	04/01/2021	3.76		00/00	701-7530
SPECTRUM	7	Invoice	TV	04/01/2021	1.71		00/00	301-7530
SPECTRUM	8	Invoice	TV	04/01/2021	4.99		00/00	201-6050
SPECTRUM	9	Invoice	TV	04/01/2021	7.71		00/00	502-7530
SPECTRUM	10	Invoice	TV	04/01/2021	2.31		00/00	001-9910
SPECTRUM	11	Invoice	TV	04/01/2021	1.14		00/00	002-9910
SPECTRUM	12	Invoice	INTERNET	04/01/2021	17.81		00/00	001-9910
SPECTRUM	13	Invoice	INTERNET	04/01/2021	10.73		00/00	002-9910
SPECTRUM	1	Invoice	INTERNET-1945 FOREST	04/01/2021	8.98		00/00	201-5220
SPECTRUM	1	Invoice	UTILITY-1410 MAIN AVE	04/01/2021	8.98		00/00	502-7530
SPECTRUM	1	Invoice	UTLITY-239 E 13TH ST	04/01/2021	17.95		00/00	501-7530
Total SPECTRUM (4730):					250.24			
SYNCHRONY BANK/AMAZON (4910)								
SYNCHRONY BANK/AMAZON	1	Invoice	597783495845 OFFICE S	03/25/2021	25.19		04/21	701-9900

Name	Seq	Type	Description	Invoice Date	Total Cost	PO Number	Period	GL Account
SYNCHRONY BANK/AMAZON	2	Invoice	797754654786 BOOKS/M	03/25/2021	24.99		04/21	701-5691
SYNCHRONY BANK/AMAZON	3	Invoice	699896477634 OFFICE S	03/25/2021	39.33		04/21	701-9900
SYNCHRONY BANK/AMAZON	4	Invoice	444793854878 BOOKS/M	03/25/2021	9.62		04/21	701-5691
SYNCHRONY BANK/AMAZON	5	Invoice	938636858754 BOOKS/M	03/25/2021	357.49		04/21	701-5691
SYNCHRONY BANK/AMAZON	6	Invoice	438739443969 BOOKS/M	03/25/2021	17.93		04/21	701-5691
SYNCHRONY BANK/AMAZON	7	Invoice	786538766474 BOOKS/M	03/25/2021	25.99		04/21	701-5691
SYNCHRONY BANK/AMAZON	8	Invoice	469768368666 BOOKS/M	03/25/2021	29.37		04/21	701-5691
SYNCHRONY BANK/AMAZON	9	Invoice	767363677634 REPLACE	03/25/2021	11.54		04/21	701-5693
SYNCHRONY BANK/AMAZON	10	Invoice	689334397577 BOOKS/M	03/25/2021	94.69		04/21	701-5691
SYNCHRONY BANK/AMAZON	11	Invoice	449778377488 BOOKS/M	03/25/2021	13.59		04/21	701-5691
SYNCHRONY BANK/AMAZON	12	Invoice	LATE FEE	03/25/2021	35.00		04/21	701-5691
Total SYNCHRONY BANK/AMAZON (4910):					684.73			
THATCHER, JESSICA (5697)								
THATCHER, JESSICA	1	Invoice	REFUND ACTIVITY FEE	04/01/2021	15.00		00/00	721-5901
Total THATCHER, JESSICA (5697):					15.00			
U.S. BANK (5170)								
U.S. BANK	1	Invoice	JOY CC, SURVEYMONKE	03/24/2021	26.00		04/21	701-6210
U.S. BANK	2	Invoice	JOY CC, HUMANITIES NE	03/24/2021	50.00		04/21	702-5692
U.S. BANK	3	Invoice	JOY CC, OVERDRIVE 014	03/24/2021	8.99		04/21	702-5692
U.S. BANK	1	Invoice	OREGON OWL PELLETS	03/24/2021	131.25		04/21	702-5692
Total U.S. BANK (5170):					216.24			
UMB BANK N.A. (5200)								
UMB BANK N.A.	1	Invoice	ACCT #CN14	04/09/2021	318.00		00/00	150-9860
Total UMB BANK N.A. (5200):					318.00			
UNION BANK & TRUST CO (5205)								
UNION BANK & TRUST CO	1	Invoice	HSA FEES	04/01/2021	8.21		00/00	101-9620
UNION BANK & TRUST CO	2	Invoice	HSA FEES	04/01/2021	8.93		00/00	201-9620
UNION BANK & TRUST CO	3	Invoice	HSA FEES	04/01/2021	1.44		00/00	203-9620
UNION BANK & TRUST CO	4	Invoice	HSA FEES	04/01/2021	8.21		00/00	401-9620
UNION BANK & TRUST CO	5	Invoice	HSA FEES	04/01/2021	2.88		00/00	601-9620
UNION BANK & TRUST CO	6	Invoice	HSA FEES	04/01/2021	11.52		00/00	701-9620
UNION BANK & TRUST CO	7	Invoice	HSA FEES	04/01/2021	18.24		00/00	001-9620
UNION BANK & TRUST CO	8	Invoice	HSA FEES	04/01/2021	7.73		00/00	002-9620

Name	Seq	Type	Description	Invoice Date	Total Cost	PO Number	Period	GL Account
UNION BANK & TRUST CO	9	Invoice	HSA FEES	04/01/2021	4.84		00/00	003-9620
Total UNION BANK & TRUST CO (5205):					72.00			
UPS (5240)								
UPS	1	Invoice	POSTAGE	04/03/2021	12.52		00/00	003-9650
UPS	1	Invoice	POSTAGE	04/10/2021	7.01		00/00	003-9650
Total UPS (5240):					19.53			
VAN KIRK BROS CONTRACTING INC (5657)								
VAN KIRK BROS CONTRACTING INC	1	Invoice	2020 WATER SYSTEM IM	03/30/2021	82,133.74		00/00	002-2000
Total VAN KIRK BROS CONTRACTING INC (5657):					82,133.74			
VAN METER & ASSOCIATES INC (5686)								
VAN METER & ASSOCIATES INC	1	Invoice	TUITION-ARBUCKLE & G	04/08/2021	320.00		00/00	201-9760
Total VAN METER & ASSOCIATES INC (5686):					320.00			
VERIZON WIRELESS (5295)								
VERIZON WIRELESS	1	Invoice	CELL PHONE	04/01/2021	46.26		00/00	101-5452
VERIZON WIRELESS	2	Invoice	CELL PHONE	04/01/2021	41.12		00/00	101-6201
VERIZON WIRELESS	3	Invoice	CELL PHONE	04/01/2021	46.26		00/00	201-5220
VERIZON WIRELESS	4	Invoice	CELL PHONE	04/01/2021	200.32		00/00	001-9660
VERIZON WIRELESS	5	Invoice	CELL PHONE	04/01/2021	70.20		00/00	002-9660
VERIZON WIRELESS	6	Invoice	CELL PHONE	04/01/2021	29.08		00/00	003-9660
VERIZON WIRELESS	7	Invoice	CELL PHONE	04/01/2021	70.20		00/00	401-8500
VERIZON WIRELESS	8	Invoice	CELL PHONE	04/01/2021	197.03		00/00	301-7530
VERIZON WIRELESS	9	Invoice	CELL PHONE	04/01/2021	70.20		00/00	721-8500
VERIZON WIRELESS	1	Invoice	CELL PHONE PD	04/01/2021	240.14		00/00	201-5220
Total VERIZON WIRELESS (5295):					1,010.81			
VONWIN CAPITAL MANAGMENT LP (5699)								
VONWIN CAPITAL MANAGMENT LP	1	Invoice	WINDSTREAM BANKRUP	04/06/2021	665.47		00/00	001-4916
Total VONWIN CAPITAL MANAGMENT LP (5699):					665.47			
VOSS LIGHTING (5335)								
VOSS LIGHTING	1	Invoice	HANGAR #2 LIGHTING	03/31/2021	1,985.97		04/21	050-5330

Name	Seq	Type	Description	Invoice Date	Total Cost	PO Number	Period	GL Account
Total VOSS LIGHTING (5335):					1,985.97			
WACKEL'S MACHINE SHOP (5340)								
WACKEL'S MACHINE SHOP	1	Invoice	WELD OUTRIGGER	04/12/2021	63.75		00/00	001-8460
Total WACKEL'S MACHINE SHOP (5340):					63.75			
WASTE CONNECTIONS OF NEBRASKA (5360)								
WASTE CONNECTIONS OF NEBRASKA	1	Invoice	1945 FOREST AVE	04/01/2021	59.05		00/00	201-5329
WASTE CONNECTIONS OF NEBRASKA	2	Invoice	243 E 13TH ST	04/01/2021	166.82		00/00	501-7530
WASTE CONNECTIONS OF NEBRASKA	3	Invoice	1420 MAIN AVE	04/01/2021	21.10		00/00	502-7530
WASTE CONNECTIONS OF NEBRASKA	4	Invoice	320 W 9TH ST	04/01/2021	29.53		00/00	001-8000
WASTE CONNECTIONS OF NEBRASKA	5	Invoice	320 W 9TH ST	04/01/2021	29.52		00/00	002-8000
WASTE CONNECTIONS OF NEBRASKA	6	Invoice	100 S MAIN AVE	04/01/2021	466.57		00/00	003-7530
WASTE CONNECTIONS OF NEBRASKA	7	Invoice	212 E 15TH ST	04/01/2021	77.25		00/00	401-5330
WASTE CONNECTIONS OF NEBRASKA	1	Invoice	GARBAGE COLLECTION	04/01/2021	65.00		04/21	050-7530
WASTE CONNECTIONS OF NEBRASKA	1	Invoice	GARBAGE COLLECTION	04/01/2021	56.67		04/21	050-7530
WASTE CONNECTIONS OF NEBRASKA	1	Invoice	TUXEDO PARK	04/01/2021	148.45		00/00	521-7530
WASTE CONNECTIONS OF NEBRASKA	1	Invoice	GARBAGE COLLECTION	04/01/2021	37,559.15		00/00	001-4510
WASTE CONNECTIONS OF NEBRASKA	1	Invoice	1515 FOREST AVE	04/01/2021	60.70		00/00	701-5330
Total WASTE CONNECTIONS OF NEBRASKA (5360):					38,739.81			
WILLIAMS, JOSH (5698)								
WILLIAMS, JOSH	1	Invoice	REFUND ACTIVITY FEE	04/01/2021	15.00		00/00	721-5901
Total WILLIAMS, JOSH (5698):					15.00			
WINDSTREAM (5465)								
WINDSTREAM	1	Invoice	PHONE LINES	04/03/2021	123.61		04/21	050-5220
WINDSTREAM	1	Invoice	PHONE-CITY HALL	04/04/2021	153.46		00/00	101-7530
WINDSTREAM	2	Invoice	PHONE-CITY HALL	04/04/2021	145.14		00/00	201-5220
WINDSTREAM	3	Invoice	PHONE-CITY HALL	04/04/2021	112.04		00/00	721-7530
WINDSTREAM	4	Invoice	PHONE-CITY HALL	04/04/2021	127.63		00/00	003-9660
WINDSTREAM	5	Invoice	PHONE-CITY HALL	04/04/2021	82.00		00/00	401-7530
WINDSTREAM	6	Invoice	PHONE-CITY HALL	04/04/2021	123.96		00/00	001-9660
WINDSTREAM	7	Invoice	PHONE-CITY HALL	04/04/2021	61.98		00/00	002-9660
WINDSTREAM	1	Invoice	PHONE-COMM CTR	04/05/2021	58.60		00/00	502-7530
WINDSTREAM	1	Invoice	PHONE-FIRE	04/05/2021	61.60		00/00	301-7530
WINDSTREAM	1	Invoice	PHONE-EMERGENCY M	04/05/2021	74.75		00/00	101-5490

Name	Seq	Type	Description	Invoice Date	Total Cost	PO Number	Period	GL Account
WINDSTREAM	1	Invoice	PHONE-NMPP	04/05/2021	71.63		00/00	001-9660
WINDSTREAM	1	Invoice	PHONE-POLICE	04/05/2021	665.35		00/00	201-5220
WINDSTREAM	1	Invoice	PHONE-SC E911	04/07/2021	545.36		00/00	202-5220
Total WINDSTREAM (5465):					2,407.11			
Grand Totals:					390,169.34			

Report GL Period Summary

GL Period	Amount
04/21	30,181.60
00/00	359,987.74
Grand Totals:	390,169.34

Vendor number hash: 594132
 Vendor number hash - split: 1092600
 Total number of invoices: 195
 Total number of transactions: 370

Terms Description	Invoice Amount	Discount Amount	Net Invoice Amount
Open Terms	390,169.34	.00	390,169.34
Grand Totals:	390,169.34	.00	390,169.34

RESOLUTION NO. 2021-02

A RESOLUTION OF THE CITY OF CRETE, NEBRASKA DECLARING A VACANCY IN THE ELECTIVE OFFICE OF COUNCILMEMBER FOR THE FIRST WARD AND PROVIDING FOR PUBLIC NOTICE.

WHEREAS, Councilmember Brian Carnes, elected to represent the First Ward in November 2018, tragically passed away on April 14, 2021;

WHEREAS, Councilmember Carnes was a dedicated public servant who passionately advocated for his constituents and worked hard to serve the City of Crete with magnanimity and sincerity; and,

WHEREAS, with the sudden passing of Councilmember Carnes, a vacancy was created in the elective office of Councilmember for the First Ward of the City of Crete, Nebraska for the remainder of the four year term ending December 1, 2022;

NOW, THEREFORE, BE IT RESOLVED BY THE MAYOR AND CITY COUNCIL OF THE CITY OF CRETE, NEBRASKA:

Section 1. That public notice of the vacancy in the elective office of Councilmember for the First Ward of the City of Crete, Nebraska shall be published in a newspaper of general circulation stating the office vacated and the length of the unexpired term.

Section 2. That the issue of filling such vacancy shall be placed on the agenda for the next regular meeting of the City Council; at which time, the Mayor shall submit the name of a qualified registered voter to fill the vacancy for the balance of the unexpired term, subject to City Council approval.

PASSED AND ADOPTED this 20th day of April 2021.

Mayor

ATTEST:

City Clerk



CITY OF CRETE
APPLICATION FOR
SPECIAL EXCEPTION PERMIT

Special Exception Fee \$160

DATE OF APPLICATION: 2/25/21 APPLICATION #:

ADDRESS OR LOCATION: Highway 103, NW Corner of 605 S. Arizona St, Crete, NE

UNDER THE PROVISIONS OF SECTION 11-230 OF THE CITY OF CRETE ZONING REGULATIONS
THE UNDERSIGNED HEREBY APPLIES FOR A SPECIAL EXCEPTION PERMIT TO:

Construct a new billboard with 2 back to back 12'X24' advertising face. OAH of the structure will be 30'

The structure will have no lights or electric.

ON THE PROPERTY DESCRIBED AS LOT(S)

BLOCK ADDITION

PROPOSED DEVELOPMENT OF THE PROPERTY IS SHOWN AND PLANS ATTACHED HERETO.
TYPE AND PROPOSED USE IS AS FOLLOWS:

Advertsing Billboard

APPLICANT NAME: PBS Aircraft Company/Link Media Outdoor

ADDRESS:
4717 F St., Omaha, NE 68117

E-MAIL ADDRESS:
chager@linkmediaoutdoor.com

TELEPHONE #: 573-489-5974 SIGNATURE: [Handwritten Signature]

FOR OFFICIAL USE ONLY BELOW THIS LINE

DATE PUBLISHED & POSTED: Apr. 7, 2021

DATE OF CITY COUNCIL HEARING: Apr. 20, 2021

CONDITIONS:

APPROVED: DENIED:

COPY TO:
BUILDING INSPECTOR: DATE
CITY CLERK: DATE

Proposed Billboard

DATE: 03.02.2020

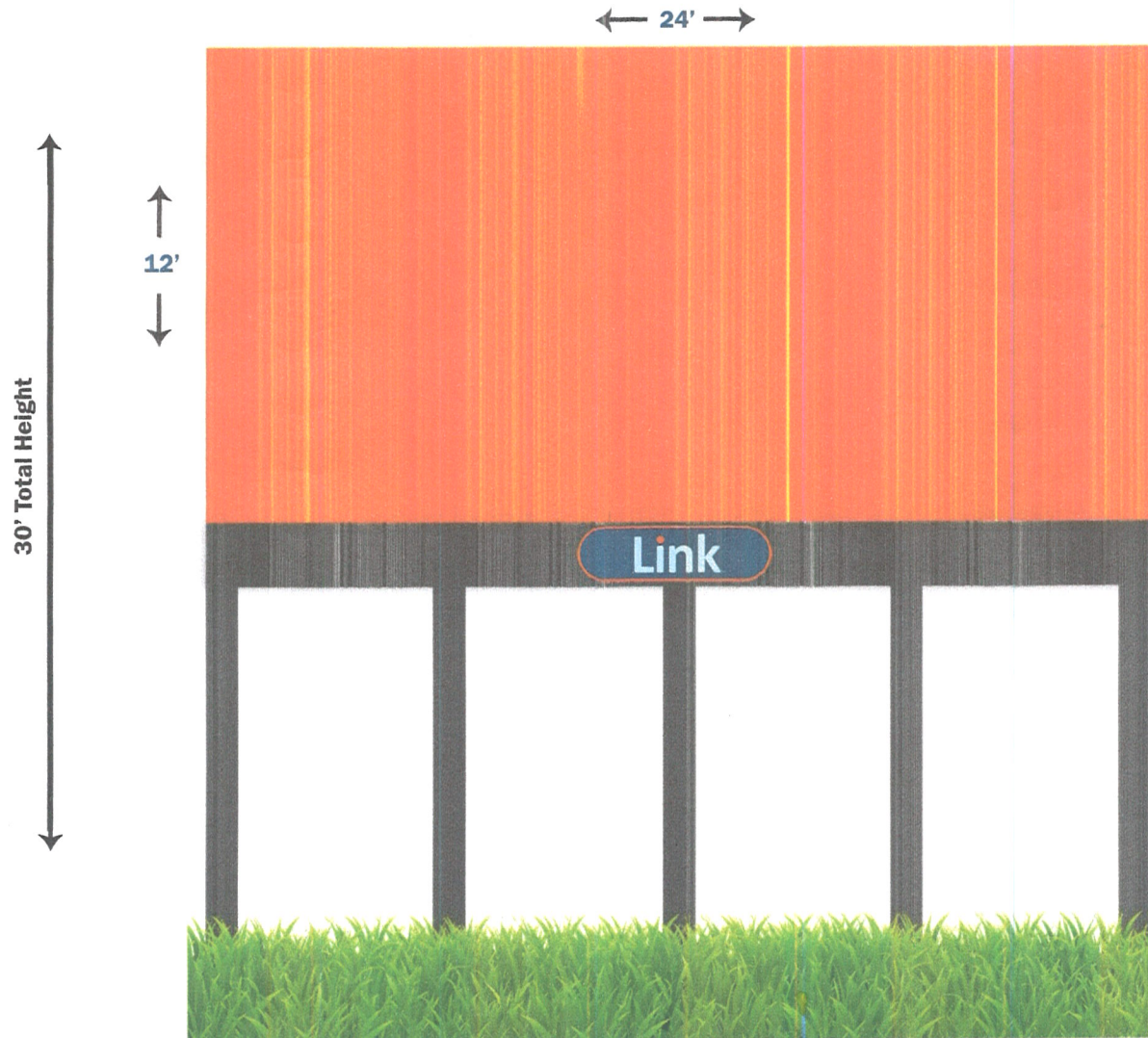

Face Size: 12x24 Total Board Height: 30'

Link

PLOT PLAN
NORTH

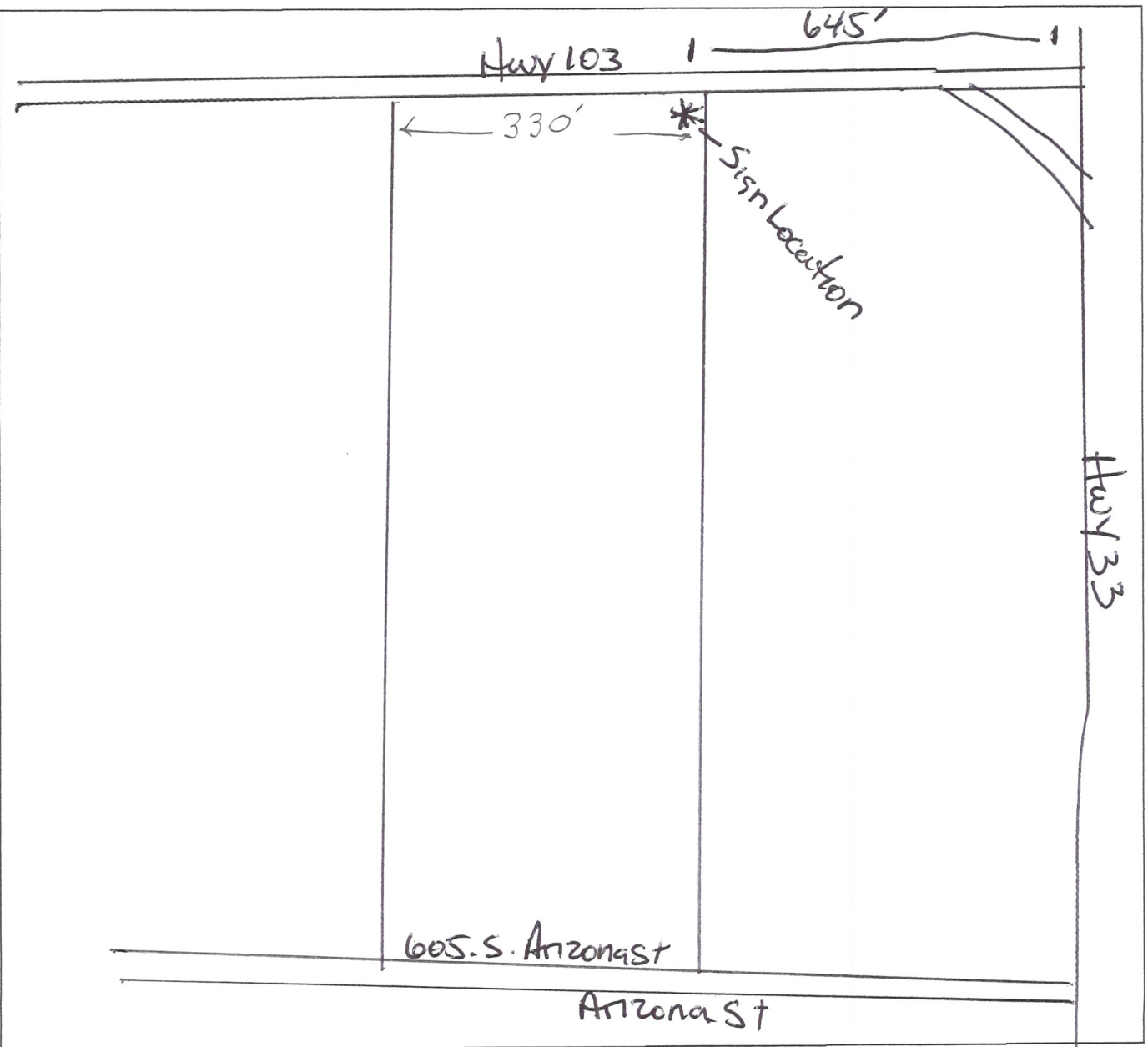

Please show location of sign or signs on the property, relative to all property lines. Any encroachment or overhang beyond the property lines will require an additional permit or variance. Questions? E-mail rsueper@crete-ne.gov.



3/9/2021

Saline County

Parcels

PID	OwnerName	PropertyAddress	OwnerAddress	LegalDesc
760142270	PBS AIRCRAFT CO INC	CRETE PRCT	PO BOX 45 CRETE, NE 68333-	CRETE PRCT PT S 1/2 NE 1/4 SE 1/4 NW 1/4 SEC. 33-8-4 3.70 ACRES~~~~

Sections

T	R	SEC	TR
8	4E	33	8-4E



CITY OF CRETE
AND TWO MILE ZONING LIMIT
243 EAST 13TH STREET
CRETE, NE 68333

APPLICATION FOR SIGN PERMIT

FEE: \$ _____ NUMBER: _____ DATE: 3/9/2021

REAL ESTATE OWNER'S NAME: PBS Aircraft Company
REAL ESTATE OWNER'S ADDRESS: 1807 Grove Ave Crete, NE 68333
REAL ESTATE OWNER'S PHONE: 402-826-5188
INSTALLER'S NAME: Link Media Outdoor
INSTALLER'S ADDRESS: 4717 F St, Omaha, NE 68130
INSTALLER'S PHONE: 402-681-8000-2230
SIGN OWNER'S NAME: Link Media Omaha LLC
SIGN OWNER'S ADDRESS: 4717 F St, Omaha, NE 68130
SIGN OWNER'S PHONE: 573-489-5974
SIGN LOCATION: 605 S. Arizona St, Crete, NE
LEGAL DESCRIPTION: LOT: See Attached.
CONTACT E-MAIL: Chager@LinkMediaOutdoor.com

TYPE OF SIGN: ADVERTISING: [checked] INFORMATIONAL: _____ DIRECTIONAL: _____
SIZE OF SIGN: 12'x24' Back to back CLEARANCE OF SIGN TO GROUND: 18'
"SIGT-TRIANGLE" COMPLIANT: _____ OVERALL HEIGHT OF SIGN: 30'
CONSTRUCTION MATERIAL TO BE USED: Wood

WILL SIGN BE ILLUMINATED? YES _____ NO [checked]
ELECTRICIAN'S NAME: N/A
ELECTRICIAN'S ADDRESS: N/A
ELECTRICIAN'S PHONE: N/A

WILL SIGN PROJECT BEYOND THE PROPERTY LINE? YES _____ NO [checked] # OF FEET? _____
WILL SUPPORT FOR SIGN BE LOCATED ON PUBLIC PROPERTY? YES _____ NO [checked]
IS A STATE OF NEBRASKA SIGN PERMIT REQUIRED? (HIGHWAY FRONTAGE) YES [checked] NO _____

SIGNATURE OF APPLICANT: [Signature]
SIGNATURE OF BUILDING INSPECTOR: _____

* PERMIT IS INVALID WITHOUT ATTACHED, APPROVED SITE PLAN AND DIAGRAM.
REFER TO CRETE MUNICIPAL CODE SIGN REQUIREMENTS, SECTION 11-519.01

LAST UPDATED ON 6/21/17.

MAR 15 2021 [Stamp]

SECURITY FEATURES INCLUDE TRUE WATERMARK PAPER, HEAT SENSITIVE ICON AND FOIL HOLOGRAM.

FIRST REPUBLIC BANK

17621

11-8166/3210

CHECK ARMOR
66
FRAUD PROTECTION

LINK MEDIA SERVICES LLC
200 MANSELL CT E
STE 360
ROSWELL, GA 30076

03/02/2021

\$ **160.00**

PAY TO THE ORDER OF City of Crete

One Hundred Sixty Dollars

DOLLARS

City of Crete



Frank Turner

AUTHORIZED SIGNATURE

MEMO

⑈017621⑈ ⑆321081669⑆ 80006956512⑈

Details on Back. Security Features Included

**APPLICATION FOR LIQUOR LICENSE
CHECKLIST - RETAIL**

NEBRASKA LIQUOR CONTROL COMMISSION
301 CENTENNIAL MALL SOUTH
PO BOX 95046
LINCOLN, NE 68509-5046
PHONE: (402) 471-2571
FAX: (402) 471-2814
Website: www.lcc.nebraska.gov

RECEIVED		
MAR 24 2021		
NEBRASKA LIQUOR CONTROL COMMISSION		
Hot List: YES (NO)	New/Replacing #	122524
Class Type	I	124183 Initial BH

Applicant name The 1206 LLC
Trade name The 1206
Previous trade name NA
Contact email address clayne@the1206.com

Provide all the items requested. Failure to provide any item will cause this application to be returned or placed on hold. All documents must be legible. Any false statement or omission may result in the denial, suspension, cancellation or revocation of your license. If your operation depends on receiving a liquor license, the Nebraska Liquor Control Commission cautions you that if you purchase, remodel, start construction, spend or commit money that you do so at your own risk. Prior to submitting your application review the application carefully to ensure that all sections are complete, and that any omissions or errors have not been made. You may want to check with the city/village or county clerk, where you are making application, to see if any additional requirements must be met before submitting application to the Nebraska Liquor Control Commission.

Crum hx

*lease
4-30-26*

RECEIPT	DATE <u>3-24-21</u> No. 170108
	FROM <u>The 1206 LLC</u>
	FOR <u>LIQUOR</u>
	<input type="checkbox"/> CASH <input checked="" type="checkbox"/> CHECK # <u>1503</u> \$ <u>400-</u> <input type="checkbox"/> MONEY# _____ <input type="checkbox"/> ORDER _____
Received by <u>[Signature]</u>	

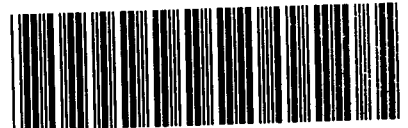
CK 1503 - \$400 - Ret 170108 BR	 2100003903
---------------------------------------	--

FORM 100
REV FEB 2017
PAGE 1
RECEIVED

1. Fingerprints are required for each person as defined in new application guide, found on our website under "Licensing Tab" in "Guidelines/Brochures". See _____ for further information, this form **MUST** be included with your application.
2. Enclose application fee of \$400 (nonrefundable), check made payable to the Nebraska Liquor Control Commission or you may pay online at _____
3. Enclose the appropriate application forms;
 - Individual License (requires insert form 1)
 - Partnership License (requires insert form 2)
 - Corporate License (requires insert form 3a & 3c)
 - Limited Liability Company (LLC) (requires form 3b & 3c)
4. If building is being leased send a copy of signed lease. Be sure the lease reads in the name of the individual(s), corporation or Limited Liability Company (LLC) making application. Lease term must run through the license year being applied for.
5. If building is owned or being purchased send a copy of the deed or purchase agreement in the name of the applicant.
6. If buying the business of a current liquor license holder:
 - a. Provide a copy of the purchase agreement from the seller (must read applicants name)
 - b. Provide a copy of alcohol inventory being purchased (must include brand names and container size)
 - c. Enclose a list of the assets being purchased (furniture, fixtures and equipment)
7. If requesting to operate on current liquor license; enclose Temporary Operating Permit (TOP) (_____).
8. Enclose a list of any inventory or property owned by other parties that are on the premises.
9. For citizenship enclose U.S. birth certificate; U.S. passport or naturalization paper
 - a. For residency enclose proof of registered voter in Nebraska
 - b. If permanent resident include Employment Authorization Card or Permanent Resident Card
 - c. See _____ for further assistance
10. Corporation or Limited Liability Company (LLC) must enclose a copy of articles of incorporation; as filed with the Secretary of State's Office.
11. Submit a copy of your business plan.

I acknowledge that this application is not a guarantee that a liquor license will be issued to me, and that the average processing period is 60 days. Furthermore, I understand that all the information is truthful and I accept all responsibility for any false documents.

Signature

Feb 23, 2021
Date

1. Fingerprints are required for each person as defined in new application guide, found on our website under "Licensing Tab" in "Guidelines/Brochures". See [FORM 100](#) for further information, this form **MUST** be included with your application.
2. Enclose application fee of \$400 (nonrefundable), check made payable to the Nebraska Liquor Control Commission or you may pay online at [PAY ONLINE](#).
3. Enclose the appropriate application forms;
 - Individual License (requires insert form 1)
 - Partnership License (requires insert form 2)
 - Corporate License (requires insert form 3a & 3c)
 - Limited Liability Company (LLC) (requires form 3b & 3c)
4. If building is being leased send a copy of signed lease. Be sure the lease reads in the name of the individual(s), corporation or Limited Liability Company (LLC) making application. Lease term must run through the license year being applied for.
5. If building is owned or being purchased send a copy of the deed or purchase agreement in the name of the applicant.
6. If buying the business of a current liquor license holder:
 - a. Provide a copy of the purchase agreement from the seller (must read applicants name)
 - b. Provide a copy of alcohol inventory being purchased (must include brand names and container size)
 - c. Enclose a list of the assets being purchased (furniture, fixtures and equipment)
7. If requesting to operate on current liquor license; enclose Temporary Operating Permit (TOP) ([FORM 100](#)).
8. Enclose a list of any inventory or property owned by other parties that are on the premises.
9. For citizenship enclose U.S. birth certificate; U.S. passport or naturalization paper
 - a. For residency enclose proof of registered voter in Nebraska
 - b. If permanent resident include Employment Authorization Card or Permanent Resident Card
 - c. See [FORM 100](#) for further assistance
10. Corporation or Limited Liability Company (LLC) must enclose a copy of articles of incorporation; as filed with the Secretary of State's Office.
11. Submit a copy of your business plan.

I acknowledge that this application is not a guarantee that a liquor license will be issued to me, and that the average processing period is 60 days. Furthermore, I understand that all the information is truthful and I accept all responsibility for any false documents.

Signature

Feb 23, 2021
Date

**APPLICATION FOR LIQUOR LICENSE
RETAIL**

NEBRASKA LIQUOR CONTROL COMMISSION
301 CENTENNIAL MALL SOUTH
PO BOX 95046
LINCOLN, NE 68509-5046
PHONE: (402) 471-2571
FAX: (402) 471-2814
Website: www.lcc.nebraska.gov/

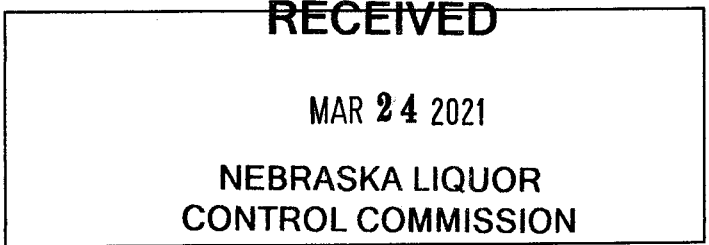

**CLASS OF LICENSE FOR WHICH APPLICATION IS MADE AND FEES
CHECK DESIRED CLASS**

- RETAIL LICENSE(S)** Application Fee \$400 (nonrefundable)
- A BEER, ON SALE ONLY
 - B BEER, OFF SALE ONLY
 - C BEER, WINE, DISTILLED SPIRITS, ON AND OFF SALE
 - D BEER, WINE, DISTILLED SPIRITS, OFF SALE ONLY
 - I BEER, WINE, DISTILLED SPIRITS, ON SALE ONLY
 - J LIMITED ALCOHOLIC LIQUOR, OFF SALE – MUST INCLUDE SUPPLEMENTAL FORM 120
 - AB BEER, ON AND OFF SALE
 - AD BEER ON SALE ONLY, BEER, WINE, DISTILLED SPIRITS OFF SALE
 - IB BEER, WINE, DISTILLED SPIRITS ON SALE, BEER OFF SALE ONLY

Class K Catering license (requires catering application form 106) \$100.00

Additional fees will be assessed at city/village or county level when license is issued

Class C license term runs from November 1 – October 31
All other licenses run from May 1 – April 30
Catering license (K) expires same as underlying retail license

CHECK TYPE OF LICENSE FOR WHICH YOU ARE APPLYING

- Individual License (requires insert 1 **FORM 101**)
- Partnership License (requires insert 2 **FORM 102**)
- Corporate License (requires insert 3a **FORM 103** & 3c **FORM 104**)
- Limited Liability Company (LLC) (requires form 3b **FORM 105** & 3c **FORM 104**)

**NAME OF ATTORNEY OR FIRM ASSISTING WITH APPLICATION (if applicable)
Commission will call this person with any questions we may have on this application**

Name _____ Phone number: _____

Firm Name _____

PREMISES INFORMATION

Trade Name (doing business as) The 1206

Street Address #1 1206 Main Ave

Street Address #2 _____

City Crete County Saline 22 Zip Code 68333

Premises Telephone number 402-309-5206 +12266

Business e-mail address elayne@the1206.com

Is this location inside the city/village corporate limits: YES NO

Mailing address (where you want to receive mail from the Commission) _____

Name Elayne Woods Jones

Street Address #1 15255 SW 114th St.

Street Address #2 _____

City Crete State NE Zip Code 68333

DESCRIPTION AND DIAGRAM OF THE STRUCTURE TO BE LICENSED

READ CAREFULLY

In the space provided or on an attachment draw the area to be licensed. This should include storage areas, basement, outdoor area, sales areas and areas where consumption or sales of alcohol will take place. If only a portion of the building is to be covered by the license, you must still include dimensions (length x width) of the licensed area as well as the dimensions of the entire building. No blue prints please. Be sure to indicate the direction north and **number of floors** of the building.

**For on premises consumption liquor licenses minimum standards must be met by providing at least two restrooms

Building: length 100 x width 45 in feet

Is there a basement? Yes No

If yes, length 100 x width 45 in feet

Is there an outdoor area? Yes No

If yes, length 45 x width 5 in feet

PROVIDE DIAGRAM OF AREA TO BE LICENSED BELOW OR ATTACH SEPARATE SHEET

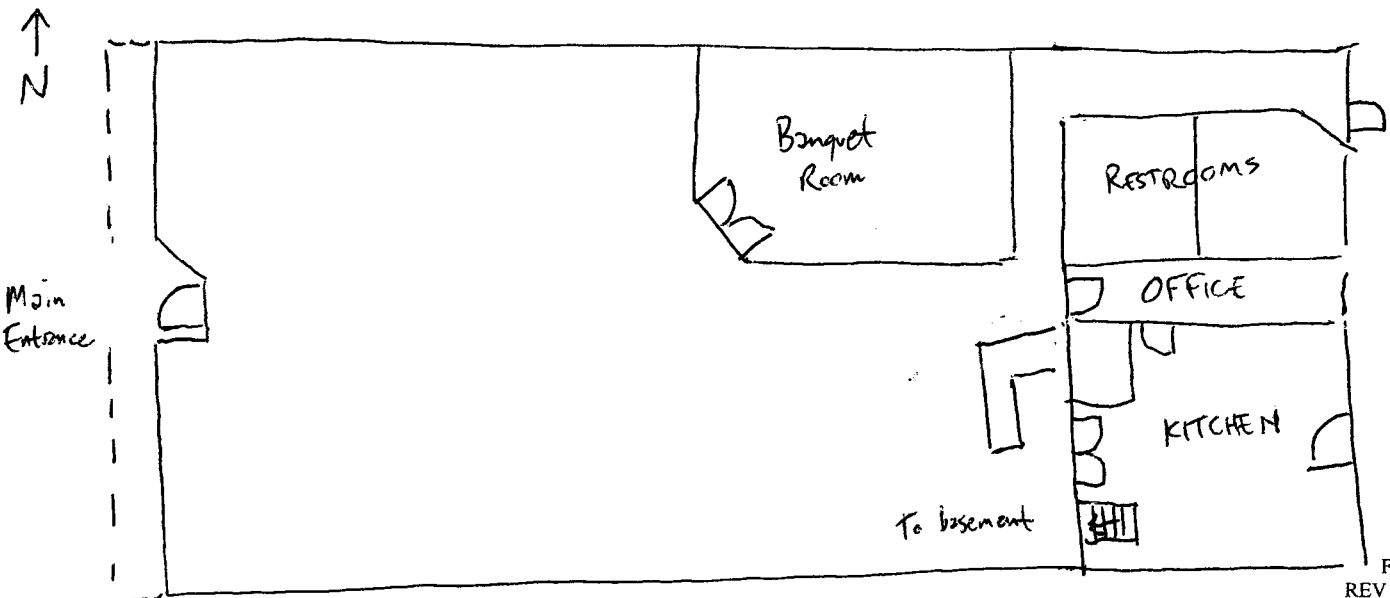

APPLICANT INFORMATION

1. **READ CAREFULLY. ANSWER COMPLETELY AND ACCURATELY §53-125(5)**

Has anyone who is a party to this application, or their spouse, EVER been convicted of or plead guilty to any charge. Charge means any charge alleging a felony, misdemeanor, violation of a federal or state law; a violation of a local law, ordinance or resolution. List the nature of the charge, where the charge occurred and the year and month of the conviction or plea. Also list any charges pending at the time of this application. If more than one party, please list charges by each individual's name. Include traffic violations. Commission must be notified of any arrests and/or convictions that may occur after the date of signing this application.

YES NO

If yes, please explain below or attach a separate page

Name of Applicant	Date of Conviction (mm/yyyy)	Where Convicted (city & state)	Description of Charge	Disposition
Elayne Jones	1996/97?	Lnk, NE	minor in poss. of alcohol	fine + community service

2. Are you buying the business of a current retail liquor license?

YES NO

If yes, give name of business and liquor license number _____

- a) Submit a copy of the sales agreement
- b) Include a list of alcohol being purchased, list the name brand, container size and how many
- c) Submit a list of the furniture, fixtures and equipment

3. Was this premise licensed as liquor licensed business within the last two (2) years?

YES NO

If yes, give name and license number The Brew House 122524

4. Are you filing a temporary operating permit (TOP) to operate during the application process?

YES NO ← this one
 ↑

If yes:

- a) Attach temporary operating permit (TOP) (FORM 100)
- b) TOP will only be accepted at a location that currently holds a valid liquor license.

5. Are you borrowing any money from any source, include family or friends, to establish and/or operate the business?

YES NO

If yes, list the lender(s) City Bank and Trust

6. Will any person or entity, other than applicant, be entitled to a share of the profits of this business?

YES NO

If yes, explain. (all involved persons must be disclosed on application)

No silent partners

7. Will any of the furniture, fixtures and equipment to be used in this business be owned by others?

YES NO

If yes, list such item(s) and the owner.

8. Is premises to be licensed within 150 feet of a church, school, hospital, home for the aged or indigent persons or for veterans, their wives, and children, or within 300 feet of a college or university campus?

YES NO

If yes, provide name and address of such institution and where it is located in relation to the premises (Neb. Rev. Stat.

Provide letter of support or opposition, see 126-101 - church or 126-102 - campus

9. Is anyone listed on this application a law enforcement officer?

YES NO

If yes, list the person, the law enforcement agency involved and the person's exact duties.

10. List the primary bank and/or financial institution (branch if applicable) to be utilized by the business.

a) List the individual(s) who will be authorized to write checks and/or withdrawals on accounts at this institution.

City Bank's Trust, Crete NE // Elayne Jones + Justin Jones

11. List all past and present liquor licenses held in Nebraska or any other state by any person named in this application. Include license holder name, location of license and license number. Also list reason for termination of any license(s) previously held.

Artisan Mark LLC, Elayne Woods Jones # 123528

12. List the alcohol related training and/or experience (when and where) of the person(s) making application. Those persons required are listed as followed:

- Individual: Applicant and spouse; spouse is exempt if they filed _____ – Affidavit of Non-Participation.
- Partnership: All partners and spouses, spouses are exempt if they filed _____ – Affidavit of Non-Participation.
- Limited Liability Company: All member of LLC, Manager and all spouses; spouses are exempt if they filed Form 116 – Affidavit of Non-Participation.
- Corporation: President, Stockholders holding 25% or more of shares, Manager and all spouses; spouses are exempt if they filed _____ – Affidavit of Non-Participation.

NLCC certified training program completed:

Applicant Name	Date (mm/yyyy)	Name of program (attach copy of course completion certificate)

List of NLCC certified _____ Experience:

Applicant Name/Job Title	Date of Employment:	Name & Location of Business
Elayne Jones /owner	Apr. 2019	Artisan Mark, 1144 Main Ave, Crete

13. If the property for which this license is sought is owned, submit a copy of the deed, or proof of ownership. If leased, submit a copy of the lease covering the entire license year. **Documents must show title or lease held in name of applicant as owner or lessee in the individual(s) or corporate name for which the application is being filed.**

Lease: expiration date 4/30/2026
 Deed
 Purchase Agreement

14. When do you intend to open for business? May 1, 2021

15. What will be the main nature of business? Events

16. What are the anticipated hours of operation? variable

17. List the principal residence(s) for the past 10 years for all persons required to sign, including spouses.

RESIDENCES FOR THE PAST 10 YEARS, APPLICANT AND SPOUSE MUST COMPLETE					
APPLICANT: CITY & STATE	YEAR		SPOUSE: CITY & STATE	YEAR	
	FROM	TO		FROM	TO
Elayne Jones Crete NE	2018	present	Justin Jones Crete NE	2009	present
Lincoln, NE	2008	2018			

If necessary attach a separate sheet.

The undersigned applicant(s) hereby consent(s) to an investigation of his/her background and release present and future records of every kind and description including police records, tax records (State and Federal), and bank or lending institution records, and said applicant(s) and spouse(s) waive(s) any right or causes of action that said applicant(s) or spouse(s) may have against the Nebraska Liquor Control Commission, the Nebraska State Patrol, and any other individual disclosing or releasing said information. Any documents or records for the proposed business or for any partner or stockholder that are needed in furtherance of the application investigation of any other investigation shall be supplied immediately upon demand to the Nebraska Liquor Control Commission or the Nebraska State Patrol. The undersigned understand and acknowledge that any license issued, based on the information submitted in this application, is subject to cancellation if the information contained herein is incomplete, inaccurate or fraudulent.

Individual applicants agree to supervise in person the management and operation of the business and that they will operate the business authorized by the license for themselves and not as an agent for any other person or entity. Corporate applicants agree the approved manager will superintend in person the management and operation of the business. Partnership applicants agree one partner shall superintend the management and operation of the business. All applicants agree to operate the licensed business within all applicable laws, rules, regulations, and ordinances and to cooperate fully with any authorized agent of the Nebraska Liquor Control Commission.

Applicant Notification and Record Challenge: Your fingerprints will be used to check the criminal history records of the FBI. You have the opportunity to complete or challenge the accuracy of the information contained in FBI identification record. The procedures for obtaining a change, correction, or updating an FBI identification record are set forth in Title 28, CFR, 16.34.

Must be signed in the presence of a notary public by applicant(s) and spouse(s). See [subpart 16.34](#) for required signatures

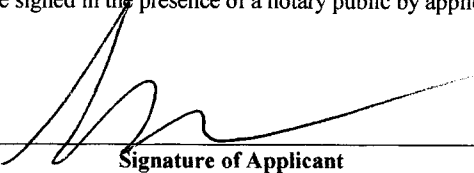

Signature of Applicant

Elayne Woods Jones

Print Name

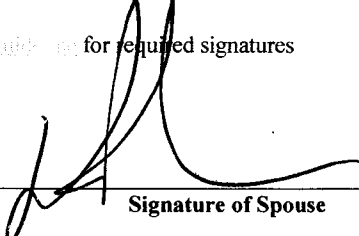

Signature of Spouse

Justin Jones

Print Name

Signature of Applicant

Print Name

Signature of Spouse

Print Name

ACKNOWLEDGEMENT

State of Nebraska
County of Saline
Feb 23, 2021
date

The foregoing instrument was acknowledged before me this

by Elayne Woods Jones & Justin Jones
name of person(s) acknowledged (individual(s) signing)



Notary Public signature

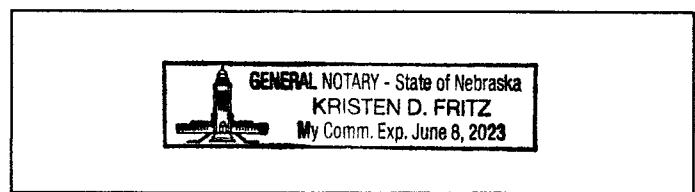

In compliance with the ADA, this application is available in other formats for persons with disabilities. A ten day advance period is required in writing to produce the alternate format.

**APPLICATION FOR LIQUOR LICENSE
LIMITED LIABILITY COMPANY (LLC)
INSERT - FORM 3b**

NEBRASKA LIQUOR CONTROL COMMISSION
301 CENTENNIAL MALL SOUTH
PO BOX 95046
LINCOLN, NE 68509-5046
PHONE: (402) 471-2571
FAX: (402) 471-2814
Website:

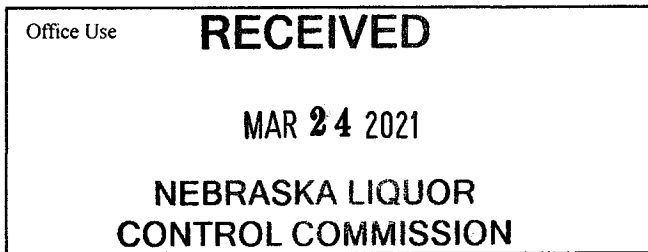

All members including spouse(s), are required to adhere to the following requirements:

- 1) All members spouse(s) must be listed
- 2) Managing/Contact member and all members holding over 25% interest and their spouse(s) (if applicable) must submit fingerprints. See Form 147 for further information, this form MUST be included with your application.
- 3) Managing/Contact member and all members holding over 25 % shares of stock and their spouse (if applicable) must sign the signature page of the Application for License form 100 (even if a spousal affidavit has been submitted)

Attach copy of Articles of Organization (must show electronic stamp or barcode receipt by Secretary of States office)

Name of Registered Agent: Elayne Woods Jones

Name of Limited Liability Company that will hold license as listed on the Articles of Organization
The 1206 LLC

LLC Address: 1206 Main Ave

City: Crete State: NE Zip Code: 68333

LLC Phone Number: 402-309-5206 LLC Fax Number +22222

Name of Managing/Contact Member
Name and information of contact member must be listed on following page

Last Name: Jones First Name: Elayne MI: W

Home Address: 15255 SW 114th St. City: Crete

State: NE Zip Code: 68333 Home Phone Number: 402-309-5206

[Handwritten Signature]
+33912

Signature of Managing/Contact Member

ACKNOWLEDGEMENT

State of Nebraska
County of Saline

Feb. 23, 2021
Date

Kristen D. Fritz

The foregoing instrument was acknowledged before me this

by Elayne Woods Jones
name of person acknowledge

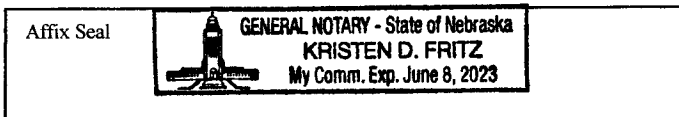

List names of all members and their spouses (even if a spousal affidavit has been submitted)

Last Name: Jones First Name: Elayne MI: W

Social Security Number: [REDACTED] Date of Birth: [REDACTED]

Spouse Full Name (indicate N/A if single): Justin Garfield Jones

Spouse Social Security Number: [REDACTED] Date of Birth: [REDACTED]

Percentage of member ownership 50%

Last Name: Jones First Name: Justin MI: G

Social Security Number: [REDACTED] Date of Birth: [REDACTED]

Spouse Full Name (indicate N/A if single): Elayne Woods Jones

Spouse Social Security Number: [REDACTED] Date of Birth: [REDACTED]

Percentage of member ownership 50%

Last Name: _____ First Name: _____ MI: _____

Social Security Number: _____ Date of Birth: _____

Spouse Full Name (indicate N/A if single): _____

Spouse Social Security Number: _____ Date of Birth: _____

Percentage of member ownership _____

Last Name: _____ First Name: _____ MI: _____

Social Security Number: _____ Date of Birth: _____

Spouse Full Name (indicate N/A if single): _____

Spouse Social Security Number: _____ Date of Birth: _____

Percentage of member ownership _____

List names of all members and their spouses (even if a spousal affidavit has been submitted)

Last Name: _____ First Name: _____ MI: _____

Social Security Number: _____ Date of Birth: _____

Spouse Full Name (indicate N/A if single): _____

Spouse Social Security Number: _____ Date of Birth: _____

Percentage of member ownership _____

Last Name: _____ First Name: _____ MI: _____

Social Security Number: _____ Date of Birth: _____

Spouse Full Name (indicate N/A if single): _____

Spouse Social Security Number: _____ Date of Birth: _____

Percentage of member ownership _____

Last Name: _____ First Name: _____ MI: _____

Social Security Number: _____ Date of Birth: _____

Spouse Full Name (indicate N/A if single): _____

Spouse Social Security Number: _____ Date of Birth: _____

Percentage of member ownership _____

Last Name: _____ First Name: _____ MI: _____

Social Security Number: _____ Date of Birth: _____

Spouse Full Name (indicate N/A if single): _____

Spouse Social Security Number: _____ Date of Birth: _____

Percentage of member ownership _____

Is the applying Limited Liability Company controlled by another corporation/company?

YES

NO

If yes, provide the following:

- 1) Name of corporation _____
- 2) Supply an organizational chart of the controlling corporation named above
- 3) Controlling corporation **MUST** be registered with the Nebraska Secretary of State, copy of articles must be submitted with application §53-126

Indicate the company's tax year with the IRS (Example January through December)

Starting Date: _____ Ending Date: _____

Is this a Non Profit Corporation?

YES

NO

If yes, provide the Federal ID #. _____

In compliance with the ADA, this corporation insert form 3a is available in other formats for persons with disabilities.
A ten day advance period is requested in writing to produce the alternate format.

Nebraska Secretary of State

THE 1206 LLC

Fri Apr 2 09:48:18 2021

SOS Account Number

2012161513

Status

Active

Principal Office Address

No address on file

Registered Agent and Office Address

ELAYNE WOODS
15255 SW 114TH ST
CRETE, NE 68333

Designated Office Address

1206 MAIN AVE
CRETE, NE 68333

Nature of Business

Not Available

Entity Type

Domestic LLC

Qualifying State: NE

Date Filed

Dec 04 2020

Next Report Due Date

Jan 01 2021

Filed Documents

Filed documents for THE 1206 LLC may be available for purchase and downloading by selecting the Purchase Now button. Your Nebraska.gov account will be charged the indicated amount for each item you view. If no Purchase Now button appears, please contact Secretary of State's office to request document(s).

Document	Date Filed	Price	
Certificate of Organization	Dec 04 2020	\$0.45 = 1 page(s) @ \$0.45 per page	<input type="button" value="Purchase Now"/>

Good Standing Documents

- If you need your Certificate of Good Standing Apostilled or Authenticated for use in another country, you must contact the Nebraska Secretary of State's office directly for information and instructions. Documents obtained from this site cannot be Apostilled or Authenticated.

Online Certificate of Good Standing with Electronic Validation

Not available. The biennial report is now due and may be filed online. Once filed, return to Corporate & Business Search to obtain an Online Certificate of Good Standing.

Certificate of Good Standing - USPS Mail Delivery
\$10.00

CERTIFICATE OF ORGANIZATION

1. The name of the Limited Liability Company is: The 1206 LLC
2. The purpose for which the company is organized is to conduct any and all lawful business.
3. The street and mailing address of the initial designated. Office is:

1206 Main Ave
Crete, Nebraska 68333

4. The name and mailing address of the initial agent for service of process of the company is:

Elayne Woods Jones
15255 SW 114th St
Crete, Nebraska 68333

5. The company is not organized to render a professional service.

6. The co-members and managers of the company are:

Elayne Woods Jones
15255 SW 114th St
Crete, Nebraska 68333

And

Justin G. Jones
15255 SW 114th St
Crete, Nebraska 68333



Elayne Woods Jones
Organizer/Co-Owner
15255 SW 114th St
Crete, Nebraska 68333

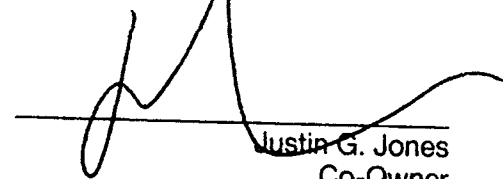

Justin G. Jones
Co-Owner
15255 SW 114th St
Crete, Nebraska 68333

**MANAGER APPLICATION
INSERT - FORM 3c**

NEBRASKA LIQUOR CONTROL COMMISSION
301 CENTENNIAL MALL SOUTH
PO BOX 95046
LINCOLN, NE 68509-5046
PHONE: (402) 471-2571
FAX: (402) 471-2814
Website: www.lcc.nebraska.gov

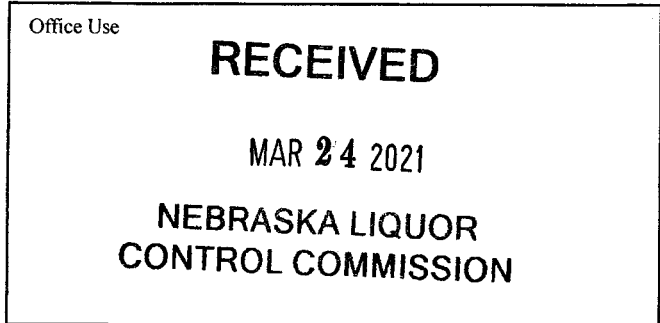

FORM MUST BE COMPLETELY FILLED OUT IN ORDER FOR APPLICATION TO BE PROCESSED

MANAGER MUST:

- Complete all sections of the application. Be sure it is signed by a **member or corporate officer**, corporate officer or member must be an individual on file with the Liquor Control Commission
- Fingerprints are required. See form 147 for further information, read form carefully to avoid delays in processing, this form **MUST** be included with your application.
- Provide a copy of one of the following: US birth certificate, naturalization papers or current US passport (even if you have provided this before)
- Be a registered voter in the State of Nebraska, include a copy of voter card or print document from Secretary of State website with application

Spouse who **will not** participate in the business, **spouse must:**

- Complete the Spousal Affidavit of Non Participation Insert (must be notarized). The non-participating spouse completes the top half; the manager completes the bottom half. **Be sure to complete both halves of this form.**
- Need not answer question #1 of the application

Spouse who **will** participate in the business, the **spouse must:**

- Sign the application
- Fingerprints are required. See form 147 for further information, read form carefully to avoid delays in processing, this form **MUST** be included with your application.
- Provide a copy of one of the following: birth certificate, naturalization papers or current US passport (even if you have provided this before)
- Be a registered voter in the state of Nebraska, include a copy of voter card with application
- Spousal Affidavit of Non Participation Insert **not** required

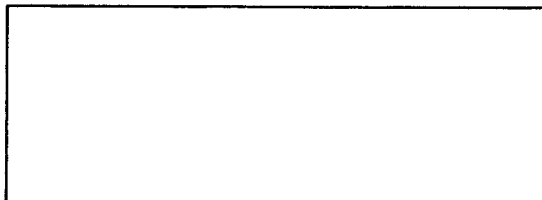

**MANAGER APPLICATION
INSERT - FORM 3c**

NEBRASKA LIQUOR CONTROL COMMISSION
301 CENTENNIAL MALL SOUTH
PO BOX 95046
LINCOLN, NE 68509-5046
PHONE: (402) 471-2571
FAX: (402) 471-2814
Website: www.lcc.nebraska.gov

Office Use
RECEIVED
MAR 24 2021
NEBRASKA LIQUOR
CONTROL COMMISSION

MUST BE:

- ✓ Include copy of US birth certificate, naturalization paper or current US passport
- ✓ Nebraska resident. Include copy of voter registration card or print out document from [Secretary of State website](#)
- ✓ Fingerprinted. See form 147 for further information, read form carefully to avoid delays in processing, this form **MUST** be included with your application
- ✓ 21 years of age or older

Corporation/LLC information

Name of Corporation/LLC: The 1206 LLC

Premise information

Liquor License Number: _____ Class Type _____ (if new application leave blank)

Premise Trade Name/DBA: The 1206

Premise Street Address: 1206 Main Ave

City: Crete County: Saline Zip Code: 68333

Premise Phone Number: NA * 2060

Premise Email address: elayne@the1206.com

The individual whose name is listed as a corporate officer or managing member as reported on insert form 3a or 3b or listed with the Commission. To see authorized officers or members search your license information [here](#).



SIGNATURE REQUIRED BY CORPORATE OFFICER / MANAGING MEMBER
(Faxed signatures are acceptable)

Manager's information must be completed below PLEASE PRINT CLEARLY

Last Name: Jones First Name: Elayne MI: W

Home Address: 15255 SW 114th St.

City: Crete County: Lancaster Zip Code: 68333

Home Phone Number: 402-309-5206

Driver's License Number & State: [REDACTED] Nebraska

Social Security Number: [REDACTED]

Date Of Birth: [REDACTED] Place Of Birth: Omaha, NE

Email address: elayne@the1206.com

Are you married? If yes, complete spouse's information (Even if a spousal affidavit has been submitted)

YES NO

Spouse's information

Spouses Last Name: Jones First Name: Justin MI: G

Social Security Number: [REDACTED]

Driver's License Number & State: [REDACTED] NE

Date Of Birth: [REDACTED] Place Of Birth: Santa Fe, NM

APPLICANT & SPOUSE MUST LIST RESIDENCE(S) FOR THE PAST TEN (10) YEARS
 APPLICANT SPOUSE

CITY & STATE	YEAR FROM	YEAR TO	CITY & STATE	YEAR FROM	YEAR TO
Crete, NE	2018	present	Crete, NE	2009	present
Lincoln, NE	2008	2018			

MANAGER'S LAST TWO EMPLOYERS

YEAR FROM TO		NAME OF EMPLOYER	NAME OF SUPERVISOR	TELEPHONE NUMBER
		Self-employed	10+ years	

1. READ CAREFULLY. ANSWER COMPLETELY AND ACCURATELY.

Must be completed by both applicant and spouse, unless spouse has filed an affidavit of non-participation.

Has anyone who is a party to this application, or their spouse, EVER been convicted of or plead guilty to any charge. Charge means any charge alleging a felony, misdemeanor, violation of a federal or state law; a violation of a local law, ordinance or resolution. List the nature of the charge, where the charge occurred and the year and month of the conviction or plea, include traffic violations. Also list any charges pending at the time of this application. If more than one party, please list charges by each individual's name. Commission must be notified of any arrests and/or convictions that may occur after the date of signing this application.

YES NO

If yes, please explain below or attach a separate page.

Name of Applicant	Date of Conviction (mm/yyyy)	Where Convicted (City & State)	Description of Charge	Disposition
Elzyna Jones	1996/97	LAK, NE	minor in possession of alcohol	fine / community serv.

2. Have you or your spouse ever been approved or made application for a liquor license in Nebraska or any other state?

YES NO

IF YES, list the name of the premise(s):

Artisan Markt, Crete, NE

3. Do you, as a manager, qualify under Nebraska Liquor Control Act (33-1310) and do you intend to supervise, in person, the management of the business?

YES NO

4. List the alcohol related training and/or experience (when and where) of the person making application.

*NLCC Training Certificate Issued: _____ Name on Certificate: _____

Applicant Name	Date (mm/yyyy)	Name of program (attach copy of course completion certificate)

*For list of NLCC Certified Training Programs see training

Experience:

Applicant Name / Job Title	Date of Employment:	Name & Location of Business:

5. Have you enclosed form 147 regarding fingerprints?

YES NO

PERSONAL OATH AND CONSENT OF INVESTIGATION

The above individual(s), being first duly sworn upon oath, deposes and states that the undersigned is the applicant and/or spouse of applicant who makes the above and foregoing application that said application has been read and that the contents thereof and all statements contained therein are true. If any false statement is made in any part of this application, the applicant(s) shall be deemed guilty of perjury and subject to penalties provided by law. Nebraska Liquor Control Act.

The undersigned applicant hereby consents to an investigation of his/her background including all records of every kind and description including police records, tax records (State and Federal), and bank or lending institution records, and said applicant and spouse waive any rights or causes of action that said applicant or spouse may have against the Nebraska Liquor Control Commission and any other individual disclosing or releasing said information to the Nebraska Liquor Control Commission. If spouse has NO interest directly or indirectly, a spousal affidavit of non-participation may be attached.

The undersigned understand and acknowledge that any license issued, based on the information submitted in this application, is subject to cancellation if the information contained herein is incomplete, inaccurate, or fraudulent.

Applicant Notification and Record Challenge: Your fingerprints will be used to check the criminal history records of the FBI. You have the opportunity to complete or challenge the accuracy of the information contained in FBI identification record. The procedures for obtaining a change, correction, or updating an FBI identification record are set forth in Title 28, CFR, 16.34.

Signature of Manager Applicant

Signature of Spouse

ACKNOWLEDGEMENT

State of Nebraska
County of Saline The foregoing instrument was acknowledged before me this

26th Day of Feb. 2021 by Elayse W. Jones & Justin G. Jones
date NAME OF PERSON BEING ACKNOWLEDGED

Berniece A. Prokop
Notary Public signature

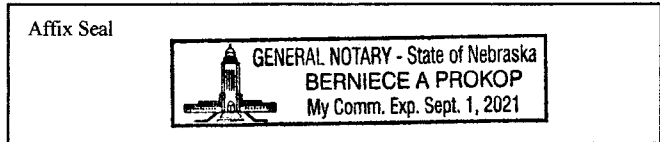

In compliance with the ADA, this application is available in other formats for persons with disabilities. A ten day advance period is required in writing to produce the alternate format.

**PRIVACY ACT STATEMENT/
SUBMISSION OF FINGERPRINTS /
PAYMENT OF FEES TO NSP-CID**

NEBRASKA LIQUOR CONTROL COMMISSION
301 CENTENNIAL MALL SOUTH
PO BOX 95046
LINCOLN, NE 68509-5046
PHONE: (402) 471-2571
FAX: (402) 471-2814
Website: www.lcc.nebraska.gov

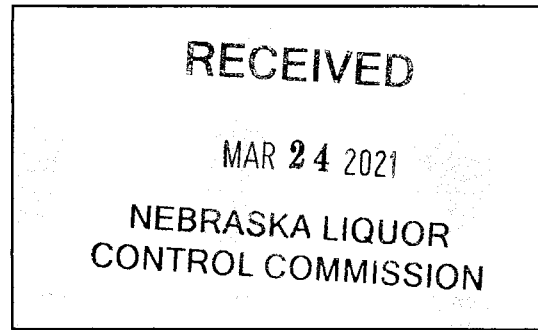

**THIS FORM IS REQUIRED TO BE SIGNED BY EACH PERSON BEING FINGERPRINTED:
DIRECTIONS FOR SUBMITTING FINGERPRINTS AND FEE PAYMENTS:**

- **FAILURE TO FILE FINGERPRINT CARDS AND PAY THE REQUIRED FEE TO THE NEBRASKA STATE PATROL WILL DELAY THE ISSUANCE OF YOUR LIQUOR LICENSE**
- Fee payment of **\$45.25 per person** **MUST** be made **DIRECTLY** to the Nebraska State Patrol;
It is recommended to make payment through the **NSP PayPort** online system at www.ne.gov/go/nsp
Or a check made payable to **NSP** can be mailed directly to the following address:
*****Please indicate on your payment who the payment is for (the name of the person being fingerprinted) and the payment is for a Liquor License*****
The Nebraska State Patrol – CID Division
3800 NW 12th Street
Lincoln, NE 68521
- Fingerprints taken at NSP LIVESCAN locations will be forwarded to NSP – CID
Applicant(s) will not have cards to include with license application.
- Fingerprints taken at local law enforcement offices may be released to the applicants;
Fingerprint cards should be submitted with the application.

Applicant Notification and Record Challenge: Your fingerprints will be used to check the criminal history records of the FBI. You have the opportunity to complete or challenge the accuracy of the information contained in the FBI identification record. The procedures for obtaining a change, correction, or updating a FBI identification record are set forth in Title 28, CFR, 16.34.

****Please Submit this form with your completed application to the Liquor Control Commission****

Trade Name The 1206 ~~the~~

Name of Person Being Fingerprinted: Elayne Woods Jones

Date of Birth: [REDACTED] Last 4 SSN: 4880

Date fingerprints were taken: Summer 2019

Location where fingerprints were taken: NSP HQ, Lincoln, NE

How was payment made to NSP?
 NSP PAYPORT CASH CHECK SENT TO NSP CK # _____

My fingerprints are already on file with the commission – fingerprints completed for a previous application less than 2 years ago? YES

SIGNATURE REQUIRED OF PERSON BEING FINGERPRINTED

**PRIVACY ACT STATEMENT/
SUBMISSION OF FINGERPRINTS /
PAYMENT OF FEES TO NSP-CID**

NEBRASKA LIQUOR CONTROL COMMISSION
301 CENTENNIAL MALL SOUTH
PO BOX 95046
LINCOLN, NE 68509-5046
PHONE: (402) 471-2571
FAX: (402) 471-2814

Website: www.liquor.nebraska.gov

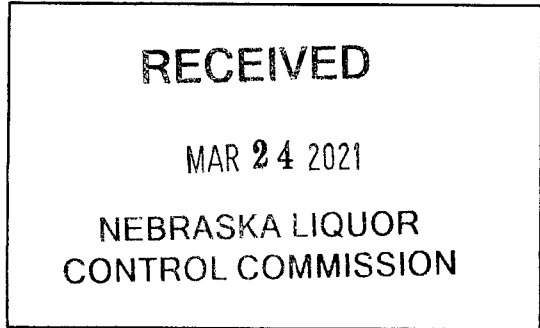

**THIS FORM IS REQUIRED TO BE SIGNED BY EACH PERSON BEING FINGERPRINTED:
DIRECTIONS FOR SUBMITTING FINGERPRINTS AND FEE PAYMENTS:**

**FAILURE TO FILE FINGERPRINT CARDS AND PAY THE REQUIRED FEE TO THE
NEBRASKA STATE PATROL WILL DELAY THE ISSUANCE OF YOUR LIQUOR LICENSE**

- Fee payment of **\$45.25 per person** **MUST** be made **DIRECTLY** to the Nebraska State Patrol;
It is recommended to make payment through the **NSP PayPort** online system at www.ne.gov/go/nsp
Or a check made payable to **NSP** can be mailed directly to the following address:

*****Please indicate on your payment who the payment is for (the name of the person being fingerprinted) and the payment is for a Liquor License*****

The Nebraska State Patrol – CID Division
3800 NW 12th Street
Lincoln, NE 68521

- Fingerprints taken at NSP LIVESCAN locations will be forwarded to NSP – CID
Applicant(s) will not have cards to include with license application.
- Fingerprints taken at local law enforcement offices may be released to the applicants;
Fingerprint cards should be submitted with the application.

Applicant Notification and Record Challenge: Your fingerprints will be used to check the criminal history records of the FBI. You have the opportunity to complete or challenge the accuracy of the information contained in the FBI identification record. The procedures for obtaining a change, correction, or updating a FBI identification record are set forth in Title 28, CFR, 16.34.

******Please Submit this form with your completed application to the Liquor Control Commission******

Trade Name The 1206, ~~1206~~

Name of Person Being Fingerprinted: Justin Jones

Date of Birth: [REDACTED] Last 4 SSN: 8611

Date fingerprints were taken: August 2019

Location where fingerprints were taken: NSP HQ, Lincoln NE

How was payment made to NSP?

NSP PAYPORT CASH CHECK SENT TO NSP CK # _____

My fingerprints are already on file with the commission – fingerprints completed for a previous application less than 2 years ago? YES

SIGNATURE REQUIRED OF PERSON BEING FINGERPRINTED

WHEN THIS COPY CARRIES THE RAISED SEAL OF THE STATE OF NEBRASKA, IT CERTIFIES THE DOCUMENT BELOW TO BE A TRUE COPY OF THE ORIGINAL RECORD ON FILE WITH THE NEBRASKA DEPARTMENT OF HEALTH AND HUMAN SERVICES, VITAL RECORDS OFFICE, WHICH IS THE LEGAL DEPOSITORY FOR VITAL RECORDS

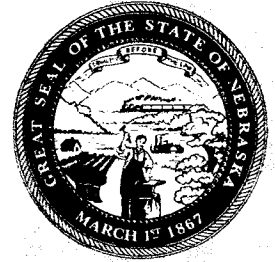

DATE OF ISSUANCE
11/16/2020
LINCOLN, NEBRASKA

Sarah Bohnenkamp
SARAH BOHNENKAMP
ASSISTANT STATE REGISTRAR
DEPARTMENT OF HEALTH
AND HUMAN SERVICES

STATE OF NEBRASKA—DEPARTMENT OF HEALTH
Bureau of Vital Statistics
CERTIFICATE OF LIVE BIRTH

126-

77 13041

CHILD—NAME FIRST MIDDLE LAST			DATE OF BIRTH (MONTH, DAY, YEAR)		BIRTH NUMBER
1 Elaine Lynn DeBusk			[REDACTED]		7b 11:02 P. M.
2 SEX	3 THIS BIRTH—SINGLE, TWIN, TRIPLE, ETC. (SPECIFY)	4 IF NOT SINGLE BIRTH—BORN FIRST, SECOND, THIRD, ETC. (SPECIFY)		5 COUNTY OF BIRTH	
Female	Single			Douglas	
6a CITY, TOWN, OR LOCATION OF BIRTH			6b HOSPITAL—NAME (IF NOT IN HOSPITAL, GIVE STREET AND NUMBER)		
Omaha			Bergan Mercy Hospital		
7a MOTHER—MAIDEN NAME FIRST MIDDLE LAST			8 AGE (AT TIME OF THIS BIRTH)	9 STATE OF BIRTH (IF NOT IN U.S.A., NAME COUNTRY)	
Catherine Mary Hall			28	Norfolk, Nebraska	
10a RESIDENCE—STATE	10b COUNTY	10c CITY, TOWN, OR LOCATION, zip code		10d STREET AND NUMBER	
Nebraska	Custer	Sargent		---	
11a FATHER—NAME FIRST MIDDLE LAST			12 AGE (AT TIME OF THIS BIRTH)	13 STATE OF BIRTH (IF NOT IN U.S.A., NAME COUNTRY)	
William Arthur DeBusk			29	Sargent, Nebraska	
14 INFORMANT—NAME OR SIGNATURE				15 RELATION TO CHILD	
Catherine M. DeBusk				Mother	
16a I CERTIFY THAT THE ABOVE NAMED CHILD WAS BORN ALIVE AT THE PLACE AND TIME AND ON THE DATE STATED ABOVE. 16b SIGNATURE			16c MAKING ADDRESS (STREET OR P.O. NO., CITY OR TOWN, STATE, ZIP)		
L. McNamara, M.D.			2722 South 87 Street		
17 ATTENDANT—M.D., D.O., OTHER (SPECIFY)			18 DATE RECEIVED BY LOCAL REGISTRAR		
M.D.			August 2, 1977		
19 REGISTRAR—SIGNATURE			20		
W.R. Jacobson, M.D., M.P.H.					

0667798

CERTIFICATE OF BIRTH
CERTIFICADO DE NACIMIENTO

**STATE OF
NEW MEXICO**

**DEPARTMENT OF HEALTH
PUBLIC HEALTH DIVISION
BUREAU OF VITAL RECORDS
AND HEALTH STATISTICS**



**ESTADO DE
NUEVO MEXICO**

**DEPARTAMENTO DE SALUD
DIVISION DE SALUD PUBLICA
OFICINA DE REGISTROS VITALES
Y ESTADISTICAS DE SALUD**

I certify that the following birth is registered in the Bureau of Vital Records and Health Statistics
Certifico que en la Seccion del Registro de Nacimientos a mi cargo aparece la siguiente inscripcion

File No. <i>Numero de Archivo</i> 78-0127-164	Request No. <i>Numero de Solicitud</i> 1-117506	County of Birth <i>Condado de Nacimiento</i> SANTA FE
Date of Birth <i>Fecha de Nacimiento</i> [REDACTED]	Date of Registration <i>Fecha de Inscripcion</i> JULY 03, 1978	
Name of Person Registered <i>Nombre del escrito</i> JUSTIN GARFIELD JONES		Sex <i>Sexo</i> MALE
Name of Father or Parent One <i>Nombre del Padre</i> MARK M JONES	Birth Name of Mother or Parent Two <i>Nombre de Soltera de la Madre</i> FAITH D GARFIELD	

No. 872052



Celina Sanchez
SIGNATURE OF STATE REGISTRAR
FIRMA DEL REGISTRADOR DEL ESTADO

DO NOT DUPLICATE BY ANY MEANS

WARNING: It is illegal to alter, copy or counterfeit this certificate **ADVERIENCIA: Es ilegal alterar, copiar o falsificar este certificado**



Elayne Woods Jones

Political Party
Nonpartisan

Precinct
Centerville

11/03/2020 2020 General Election

We did not find an absentee or provisional ballot associated with the selected election. This website does not track the status of a traditional ballot voted at the polls. If you voted a traditional ballot at the polls, your ballot has been accepted and counted.

Polling Location

Sprague-Martell Community Ctr

17500 SW 14th St Martell, NE 68404
(East door on So. Side by Gym)

Parking Info

Park on south side of facility.

View larger map

W 14th St

Martell

Google

RMap data ©2021

Ballot Styles

Cent.5

Districts

Show ▾



[Back to Lookup](#) / [Registrant Detail](#)

Justin G Jones

Political Party
Democratic

Precinct
Centerville

11/03/2020 2020 General Election

We did not find an absentee or provisional ballot associated with the selected election. This website does not track the status of a traditional ballot voted at the polls. If you voted a traditional ballot at the polls, your ballot has been accepted and counted.

Polling Location

Sprague-Martell Community Ctr

17500 SW 14th St Martell, NE 68404
(East door on So. Side by Gym)

Parking Info

Park on south side of facility.



Ballot Styles

Cent.5

Districts

Show

THE 1206

Wedding Reception Venue and Community Event Space

1206 Main Ave. Crete, Nebraska

THE 1206 is an event space with many facets - a high-end wedding reception venue and event venue that will be part of a vibrant and thriving downtown Crete. Owner Elayne Woods Jones has been in the wedding photography business for the past 10 years, and has first-hand insight on what couples are looking for in a reception venue. She also has the vision to create a space that will look beautiful in photographs, enhancing the marketability of the venue for wedding clients. In addition to being a reception venue, THE 1206 will continue the tradition of bringing people together as a community gathering space. The space will be ideal for hosting business meetings, birthday parties, fraternity and sorority socials, local fundraisers and more. Finally, THE 1206 will be known for noteworthy live music events, featuring local, regional and national performers.

With the owners' experience in the wedding and music industry, and a track record running and marketing several other successful businesses, they are confident that

THE 1206 will succeed and bring people and revenue to Crete.

Market Analysis

Market description

The wedding venue market is a consistent and high-margin industry. The consistency derives from the fact that there will always be people getting married. Average wedding-related expenditures in Nebraska average around \$30,000 per couple. According to industry reports, the venue rental is typically a large

share of overall wedding expenditures. Our area is lacking in upscale venues relative to population, with only 3 comparables within 30 miles. No similar locations exist in Crete, with most people traveling outside of town to find high-end venues.

Market trends

According to a report on the Nebraska wedding industry from The Wedding Report Inc., the long-term trend in number of weddings and expenditure per wedding in Nebraska is steady and trending slightly upward. The average expenditure on venue rental over the period 2010-2019 was approximately \$3000. High-end venues in Lincoln are charging \$6,000-\$10,000. Due to Covid-19, 2020 saw a 38% drop in wedding venue bookings. Industry projections indicate a more than 100% increase in number of bookings for 2021 (30% increase over 2019), with a lesser increase extending into 2022 and 2023 (3-4% increase over 2019). The average expenditure is also projected to rise. (See chart on next page)

Target Audience

Our target audience for the reception venue will be first-time newly-engaged couples in the 20-39 age range, and mid-high income range. Our marketing efforts will be directed specifically to the bride and/or parents of the couple. There is often a status component to the choices made by these consumers, leading to a preference for high-end/high-dollar options.

Our targeted geographic area is: a) Saline County b) Lancaster County c) Seward County.

Competitive Analysis

This analysis will focus on our geographically closest competitors: Hillside Events in Denton, Roca Ridge in Roca, Roca Berry Farm in Roca, the Ridnauer Room in Lincoln's Haymarket district, and the Talon Room in downtown Lincoln.

Hillside Events

Location: Denton, NE

Setting: Rural

Capacity: 150 inside, 100 outside

Price for Saturday wedding: \$3000 (includes Fri setup/rehearsal dinner/Sun teardown) Notes: budget option; requires decorating to look good

Roca Ridge

Location: Roca, NE

Setting: Roca

Capacity: 200 inside; 75 outside

Price for Saturday wedding: \$4750 (includes 7 AM sat-12 AM sun; coffee, breakfast, ceremony & reception)

Notes: must bring own alcohol

Roca Berry Farm

Location: Roca, NE

Setting: Rural

Capacity: 250 inside (outdoor extra)

Price for Saturday wedding: \$3200-\$4200

Notes: 18% service charge on final bill; \$750 for outside caterer

Ridnauer Room

Location: Lincoln, NE - Historic Haymarket Setting: Urban

Capacity: 300

Price for Saturday wedding: \$3375

Notes: No Bar or food service - clients bring their own

The Talon Room

Location: Lincoln, NE - Downtown Setting: Urban

Capacity: 250

Price for Saturday wedding: \$3500 Notes: require catering through venue

Competitors' Strengths

Many of our competitors offer an outdoor option for ceremonies and/or reception. They have been in business longer, and have more established brands within the wedding industry. They are in or near the population center of Lincoln.

Our Strengths

In contrast to several of our competitors' rural location and styling, we are located in a population center and offer a historic urban elegance. Also in contrast to the competition, we allow outside catering, increasing flexibility and options for clients. We will offer a stocked and staffed bar at all events.

How We Plan to Compete vs. Competitors' Strengths

We will partner with the Crete Youth Cabin to provide an outdoor ceremony location in a scenic wooded setting just south of Crete along the Blue River. Owner/Marketing Manager Elayne Woods Jones has a track record of building a brand and a fan base for her businesses, Elayne Woods Photography and Artisan Mark Coffee and Goods. She will apply her knowledge of brand building strategies to THE 1206. While slightly further from Lincoln than

the competition, we are also well positioned to solicit business from the growing areas of Saline County, Seward County, and rural southwestern Lancaster County, as well as areas to the west and south.

Description of Management and Organization

THE 1206 will be operated as a partner-managed LLC, with Justin Jones and Elayne Woods Jones as equal partners.

Elayne will assume the roles of Strategist/Visionary, Marketing and Sales Manager, and Wedding and Event Coordinator.

Justin will assume the roles of Live Music Coordinator, and Maintenance and Renovations Coordinator.

Our finances and books will be managed by Bridge Books, LLC.

We will hire a Bar Manager/Catering Facilitator and additional day-of-event staffing as needed.

Breakdown of Products and Services

Wedding Venue Rental

Our venue rental package will include: space rental for a full day; chairs, tables and linens with setup and teardown; elegant handcrafted hardwood head table; staffed and stocked cash bar; projector and screen for slideshows; and access to discounts with preferred vendors.

Community Event Space

Community Event Space rentals will feature per-hour or block rates depending on the type of event. Birthday parties, anniversaries, bridal showers, rehearsal dinners, reunions, fundraisers, club meetings, etc will be some of the possible event types. We include a staffed and stocked cash bar; tables, chairs, and linens with setup and teardown; and access to discounts with preferred vendors. Extra services include live sound for performers or speakers, big screen and projector setup; and booking services for musical acts.

Live Music Venue

THE 1206 will promote and host live music events featuring local, regional, and national performers. Our focus will be on building a base of loyal music lovers that attend our shows, augmented by the draw that booking established acts will provide. We will promote these performances as featured events or concert series, frequently enough to establish ourselves in the public's mind, while not so often as to dilute the "special event" character of the shows. Income for most shows will be generated by bar sales. Tickets will be sold for national acts or special performances only.

Marketing Plan

Our marketing plan will consist of: word-of-mouth contacts in the wedding industry, primarily with event planners and photographers; online advertising in the Knot and Wedding Wire online publications; and effective use of social media to build our brand and draw customers.

Sales Strategy

Our sales strategy will be focused on in-person sales. Elayne, with 10 years experience selling high-end wedding product, will be the primary salesperson. In addition we will hire one additional experienced salesperson. The sales process will begin by receiving an inquiry. The potential client will be contacted by our sales team to answer questions and schedule an on-site consultation. Base pricing may be provided at this time. At the consultation, we will evaluate the client's situation and provide a customized pricing quote based on their needs.

Sales goal year 1: 24 weddings

Request for Funding

Funds Needed

Downpayment Improvements Legal/appraisal/etc *total needed*
Funding Commitments City Of Crete

Cash on Hand

Equity Draw-1144 Main Ave
total available

Total investment to raise \$35,000

\$80,000 \$50,000 \$5,000 *\$135,000*

\$40,000 \$25,000 \$35,000 *\$100,000*

We are proposing to raise the capital for the last \$35,000 of funding by offering a repayment of 3.5% interest over a 5 year term, with payments made monthly.

Financial Projections

(See attached spreadsheet)

THE 1206 Monthly Operating Budget

INCOME

Weddings \$5,000 Alcohol sales @ Weddings \$6,000 Community Events \$750 Alcohol sales @ community events \$750 Music Events (Bar income) \$3,000

TOTAL INCOME \$15,500

COGS

Staffing – \$813 alcohol cost \$2,438 band cost \$1,600

TOTAL COGS \$4,850

GROSS PROFIT \$10,650

FIXED EXPENSE

rent payments \$3,000 utilities \$350 music licensing \$200 advertising \$400 Bar manager salary \$1,200 sales/marketing manager \$1,500

TOTAL FIXED EXPENSE \$6,650

NET PROFIT \$4,000

NOTES

2/mo @ \$2500

150 guests @ avg \$20 tab 3/mo @ \$250

2/mo @ \$1500

*25 hr/wedding, 8 hr/event, 12 hr/music event @ \$10/hr 25% of alcohol sales
\$800/event*

Budget

80hrs@\$15

THE 1206 WEDDING RECEPTION VENUE

2021 PRICING

SATURDAY

9am - 1am

\$2800

Friday and Sunday

9am - 1am

\$1500

Monday through Thursday

\$75/hour

2022 PRICING

SATURDAY

9am - 1am

\$3000

Friday and Sunday

9am - 1pm

\$1800

Included in reception pricing:

Space Rental

Chairs, tables and linens Setup/Teardown Stocked and Staffed Cash

Bar 1 Bartender Clean-Up

Discounted Vendors

Artisan Events

(Wedding Planner/Event Coordinator)

15% off services

Elayne Woods Photography

(wedding/engagement/boudoir photography)

15% off of any collection

Grow with the Flow

(flowers)

15% off flowers when booking The 1206

Commercial Lease Agreement

This Commercial Lease Agreement ("Lease") is made and effective Feb. 23, 2021, by and between Woods-Jones Enterprises, LLC ("Landlord") and The 1206, LLC ("Tenant").

Landlord is the owner of land and improvements commonly known and numbered as 1206 Main Ave, Crete, NE 68333.

Landlord desires to lease the Leased Premises to Tenant, and Tenant desires to lease the Leased Premises from Landlord for the term, at the rental and upon the covenants, conditions and provisions herein set forth.

THEREFORE, in consideration of the mutual promises herein contained, and other good and valuable consideration, it is agreed:

1. Term. Landlord hereby leases the Leased Premises to Tenant, and Tenant hereby leases the same from Landlord, for an "Initial Term" beginning May 1, 2021 and ending April 30, 2026. On May 1, 2021, Tenant shall have possession of the lease premises.
2. Rent. Tenant shall pay to Landlord a monthly rent during the initial term and during the renewal period lease of \$ 3,000.00 per month.
3. Use. Notwithstanding the forgoing, Tenant shall not use the Leased Premises for the purposes of storing, manufacturing or selling any explosives, flammables or other inherently dangerous substance, chemical, thing or device.
4. Sublease and Assignment. Tenant shall not sublease all or any part of the Leased Premises, or assign this Lease in whole or in part without Landlord's effective written consent.
5. Utilities. Tenant shall pay all charges for telephone, internet, and trash removal. Landlord shall pay all charges for electric, gas, water, and other utilities used by Tenant on the Leased Premises during the term of this Lease unless otherwise expressly agreed in writing by Landlord.
6. Entry. Landlord shall have the right to enter upon the Leased Premises at reasonable hours to inspect the same, provided Landlord shall not thereby unreasonably interfere with Tenant's business on the Leased Premises.

IN WITNESS WHEREOF, the parties have executed this Lease on Feb. 23, 2021.



Landlord

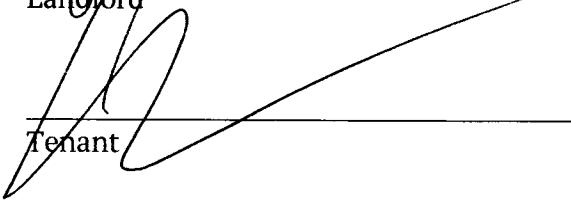

Tenant



Application for a Permit to Occupy City of Crete Right-of-Way (Rev. 2, 11-2015)

Jared Pearson

I _____ hereby request to occupy City of Crete Right-of-
Name

Way at **12th and Juniper Ave** _____ with a device or structure.
Address

Description of structure or device:

Bore from Juniper Ave in between 13th and 14th Street to 12th St and Juniper Ave.

- Diagram, or print included?
- Necessary permits and licenses obtained? Insurance?
- Approved by the Public Works Director _____ Date: _____

Note:

- 1) All applicants to occupy public right-of-way understand and agree that if, for any reason, the City or its agents require access; the obstruction shall be moved at the applicant's expense.
- 2) Any items approved for placement in the right-of-way shall be held to the building or property line as closely as possible.
- 3) If this is a 3rd party utility type project, all affected property owners shall be notified prior to the beginning of project by the project owner, or the project's contractor.
- 4) City Council approval is required for large projects (more than one property involved, or utility oriented projects).
- 5) All requests to occupy right-of-way must include a detailed sketch, print, or drawing with dimensions with respect to property lines, paving, curbs etc....
- 6) If this application is for underground sprinkler systems, a print or drawing of the system including location of lines and heads with measurements listed must accompany the application. Additionally, the applicant may be required to provide proof of proper permits to install, plumb, and provide backflow protection for said underground sprinkler systems.
- 7) Application for a permanent structure deemed to be a traffic or public safety hazard or which limit visibility will be denied.
- 8) An application shall be approved before any construction or installation is allowed to begin.

Jared Pearson

4/6/21

Signature of Applicant

Date of Application

Sacred Heart of Jesus
Catholic Church, Crete

Noa's Deli
Takeout

Burger King
Takeout

E 13th St

Juniper Ave

Ivy Ave

Grace United
Methodist Church

Casey's
Takeout

Smith Shaylene M

First Congregational
Church

th St

E 12th St

E 12th St

Juniper Ave

Ivy Ave

Google

ORDINANCE NO. 2124

AN ORDINANCE OF THE CITY OF CRETE, NEBRASKA CREATING STREET IMPROVEMENT PROJECT NOS. 2021-01, 2021-02, 2021-03, 2021-04, AND 2021-05; TO DEFINE THE BOUNDARIES AND LIMITS THEREOF; TO PROVIDE FOR PAVING, GRADING, CURBING, GUTTERING, AND OTHER NECESSARY AND INCIDENTAL WORK; TO PROVIDE FOR THE PAYMENT OF SUCH IMPROVEMENTS AND OTHER INCIDENTAL EXPENSES BY THE ISSUANCE OF WARRANTS, BOND ANTICIPATION NOTES, OR BONDS; AND TO PROVIDE FOR THE SPECIAL ASSESSMENT OF THE COSTS OF SUCH IMPROVEMENTS AGAINST THE PROPERTY SPECIALLY BENEFITED THEREBY AND A LEVY OF GENERAL TAXES.

BE IT ORDAINED BY THE MAYOR AND CITY COUNCIL OF THE CITY OF CRETE, NEBRASKA:

Section 1. That the Mayor and City Council of the City of Crete, Nebraska (“City”) hereby find and determine as follows:

- (a) That, pursuant to Sections 18-2001 to 18-2004 of the Nebraska Revised Statutes (“Act”), the City is authorized to grade, curb, gutter, and pave any unpaved street or alley that intersects a paved street for a distance of not to exceed one block on either side of such paved street.

- (b) That the City’s Main Avenue is a paved street and the Act authorizes the City to pave any street that intersects Main Avenue, including Eighteenth Street, Nineteenth Street, Twentieth Street, and Twenty-fourth Street, for a distance of one block from such intersection.

- (c) That the City’s Twenty-third Street is a paved street and the Act authorizes the City to pave any street that intersects Twenty-third Street, including Norman Avenue, for a distance of one block from such intersection.

- (d) That it is necessary, desirable, advisable, and in the best interest of the City to grade, curb, gutter, and pave (i) Eighteenth Street for a distance of not to exceed one block west of its intersection with Main Avenue under and pursuant to the Act, such work to be known as Street Improvement Project No. 2021-01 of the City (“Project 2021-01”); (ii) Nineteenth Street for a distance of not to exceed one block west of its intersection with Main Avenue under and pursuant to the Act, such work to be known as Street Improvement Project No. 2021-02 of the City (“Project 2021-02”); (iii) Twentieth Street for a distance of not to exceed one block west of its intersection with Main Avenue under and pursuant to the Act, such work to be known as Street Improvement Project No. 2021-03 of the City (“Project 2021-03”); (iv) Twenty-fourth Street for a distance of not to exceed one block west of its intersection with Main Avenue under and pursuant to the Act, such work to be known as Street Improvement Project No. 2021-04 of the City (“Project 2021-04”); and, (v) Norman Avenue for a distance of not to exceed one block north of its intersection with Twenty-third Street under and pursuant to the Act, such work to be known as Street Improvement Project No. 2021-05 of the City (“Project 2021-05”). Project 2021-01, Project 2021-02, Project 2021-03, Project 2021-04 and Project 2021-05 shall be collectively known herein as the “Projects”.

Section 2. That the Projects are hereby authorized to be constructed pursuant to the Act and shall include the grading, curbing, guttering, and paving of Eighteenth Street, Nineteenth Street, Twentieth Street, Twenty-fourth Street, and Norman Avenue for a distance of not to exceed one block as described in Section 1 above, including all incidental drainage improvements.

Section 3. That the property to be included in the Projects consists of the area for each respective Project, which are subject to special assessment, and are described as follows:

Project 2021-01: The outer boundaries of Project 2021-01 consist of a boundary line which encompasses all of the lots abutting Eighteenth Street from the intersection of Main Avenue to the intersection of Norman Avenue.

Project 2021-02: The outer boundaries of Project 2021-02 consist of a boundary line which encompasses all of the lots abutting Nineteenth Street from the intersection of Main Avenue to the intersection of Norman Avenue.

Project 2021-03: The outer boundaries of Project 2021-03 consist of a boundary line which encompasses all of the lots abutting Twentieth Street from the intersection of Main Avenue to the intersection of Norman Avenue.

Project 2021-04: The outer boundaries of Project 2021-04 consist of a boundary line which encompasses all of the lots abutting Twenty-fourth Street from the intersection of Main Avenue to the intersection of Norman Avenue.

Project 2021-05: The outer boundaries of Project 2021-05 consist of a boundary line which encompasses all of the lots abutting Norman Avenue from the intersection of Twenty-third Street to the intersection of Twenty-fourth Street.

Section 4. That JEO Consulting Group, Lincoln, Nebraska (“Engineer”) has been designated the City’s special engineer for the Projects and shall prepare detailed plans and specifications, and that prior to the letting of bids for the construction of the Projects, the Engineer shall submit the plans and specifications and an estimate of the costs of the Projects to the Mayor and City Council for approval.

Section 5. That the City shall advertise for bids for the construction of the improvements in accordance with all applicable provisions of law and shall have and hereby reserves the right to reject any and all bids received and, if all bids are rejected, to readvertise for bids.

Section 6. That the costs of the Projects shall be initially paid for by the City, but that special assessments on the properties especially benefited thereby shall be levied in proportion to the benefits derived from such improvements in order to reimburse the City to the fullest extent provided by law.

Section 7. That, for the purpose of paying the costs of the Projects, the City may issue warrants or bond anticipation notes in the form and manner provided by law, and that, to effect the final payment and retirement of such warrants and bond anticipation notes or to otherwise pay for any of the improvements authorized herein, the City may issue bonds in the form and manner provided by law.

Section 8. That all ordinances or parts of ordinances in conflict herewith shall be repealed and that any partial repeal shall not affect the other parts of ordinances that can be given effect without the repealed parts.

Section 9. That if any section, part, or provision of this ordinance is for any reason held invalid, the invalidity thereof shall not affect the validity of any other section, part, or provision of this ordinance.

Section 10. That this ordinance shall be published in pamphlet or book form and shall take effect and be in full force and effect from and after its passage, approval, and publication, as provided by law.

PASSED AND ENACTED this 20th day of April 2021.

Mayor

ATTEST:

City Clerk



13680 South 220th Street Gretna, NE 68028
Office Phone: (402) 332-4537 Fax: (402) 332-2881
Mobile Phone: Bodie (402) 670-8506

Wildwood Pool Crete, NE Deduction List/Options

Reuse existing 8" Drain Line	Deduct \$ 24,500
Waterplay (Crouch Recreation) -no controller -264 gallons a minute	Deduct \$ 6,000
Vortex Design (CRS) -with no controller -280 gallons a minute	Deduct \$ 6,000
Splashtacular Design with lower flow	Not submitting



Wildwood Pool – Crete, NE

April, 2021



COMMERCIAL **RECREATION** SPECIALISTS



**COMMERCIAL
RECREATION
SPECIALISTS**

Quote

Quote Number: 0016938
Quote Date: 4/6/2021

Commercial Recreation Specialists
807 Liberty Dr., Ste 101
Verona, WI 53593-9160
Ph: (877) 896-8442 Fx: (608) 848-8782
43-2046045

Bill To :
Dostals Construction 13680 South 220th Street Gretna, NE 68028

Ship To :
Dostals Construction Willdwood Pool - Crete, NE 13680 South 220th Street Gretna, NE 68028

Customer ID	Customer PO Number	Sales Rep Name
DOSTALS CONSTRUCTION		Patrick Pierce
Valid Through	Shipping Method	Payment Terms
5/6/2021	BEST WAY	SEE BELOW

Item	Description	Quantity	Unit Cost	Amount
VO VOR-8537.0000	Wildwood Pool - Crete, NE Custom Elevation 01	1.00	99,000.00	99,000.00
/FREIGHT	Freight and Packaging	1.00	6,000.00	6,000.00

Note: This quote is valid for 30 days. Please review the above information carefully. It defines your order as we understand it. If satisfactory, please sign and date below and fax to 608-848-8782, email back to your sales representative, or send a copy with your deposit to the address above. We will begin processing your order upon receipt of both your DEPOSIT AND APPROVAL SIGNATURE, per the terms indicated on your quote above. Additional surcharges may apply depending on final delivery address, actual delivery requirements and payment method. Please note that a 3% convenience fee may apply to credit card orders.

Net Order: 105,000.00
Freight: 0.00
Sales Tax: 0.00
Order Total: 105,000.00

Customer Acceptance: _____ Date: _____



COMMERCIAL RECREATION SPECIALISTS



Vortex Splash Pad's Notes, Exclusions, & Terms

Notes

- Off-Loading may require equipment
- Standard Lead Times are 6 – 8 weeks for Play Products, 10 weeks for Water Recirculation Equipment and 16 weeks for Elevations

Exclusions

- Receiving
- Off-Loading
- Storage
- Installation
- Fees and Permits
- Health Depart Approval and OSHA Paperwork
- Electrical and Plumbing
- Excavation
- Site Work and Site Restoration
- Surfacing
- Stamped Drawings

Terms:

- 50% due upon acceptance of this quote
- 50% remaining due upon receiving of materials



Colored concrete and environment are for illustration purposes only and not supplied by Vortex. Not for construction. Actual colors and textures of products and materials may appear differently than pictured.

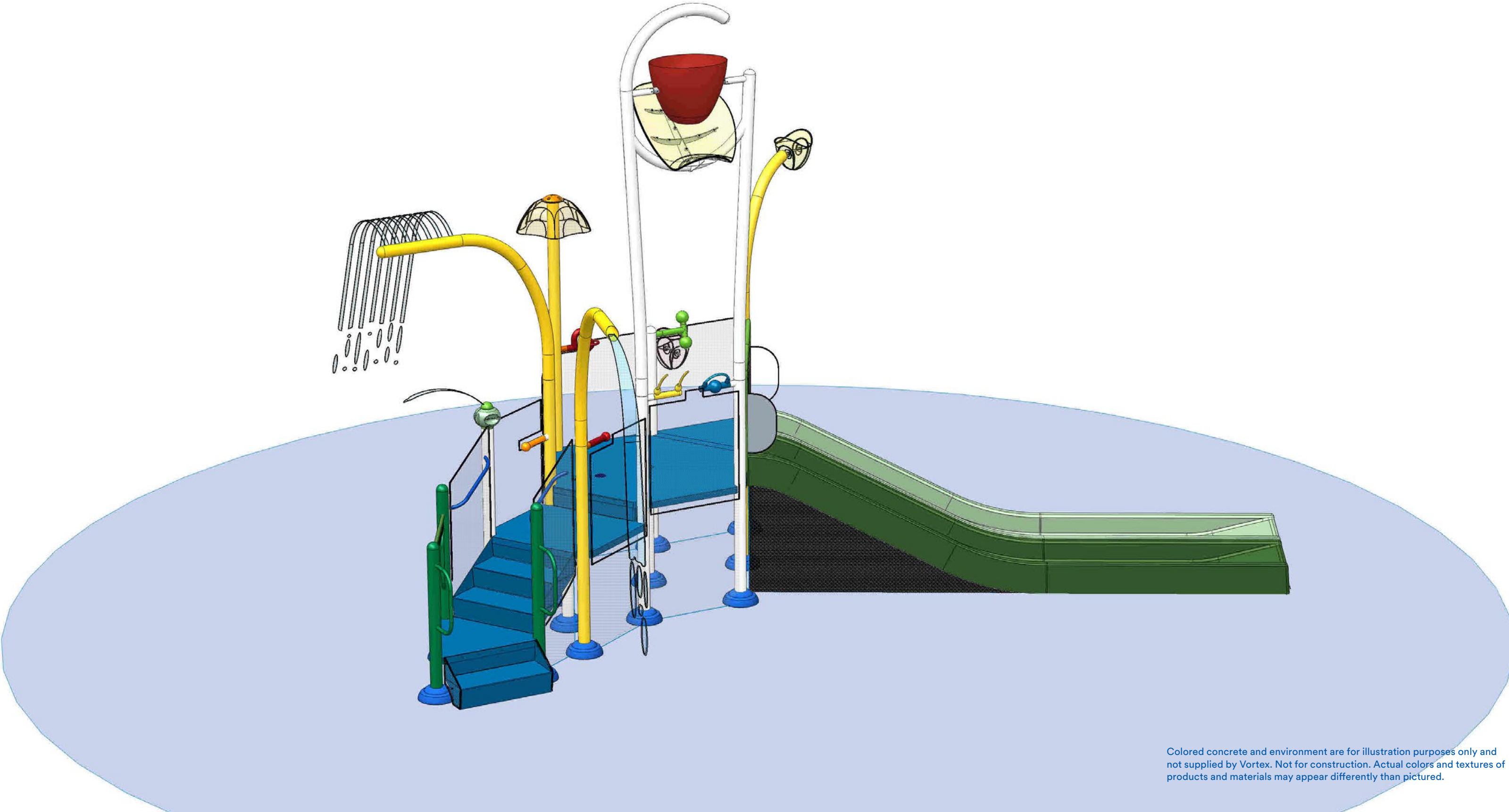

Colored concrete and environment are for illustration purposes only and not supplied by Vortex. Not for construction. Actual colors and textures of products and materials may appear differently than pictured.



Colored concrete and environment are for illustration purposes only and not supplied by Vortex. Not for construction. Actual colors and textures of products and materials may appear differently than pictured.

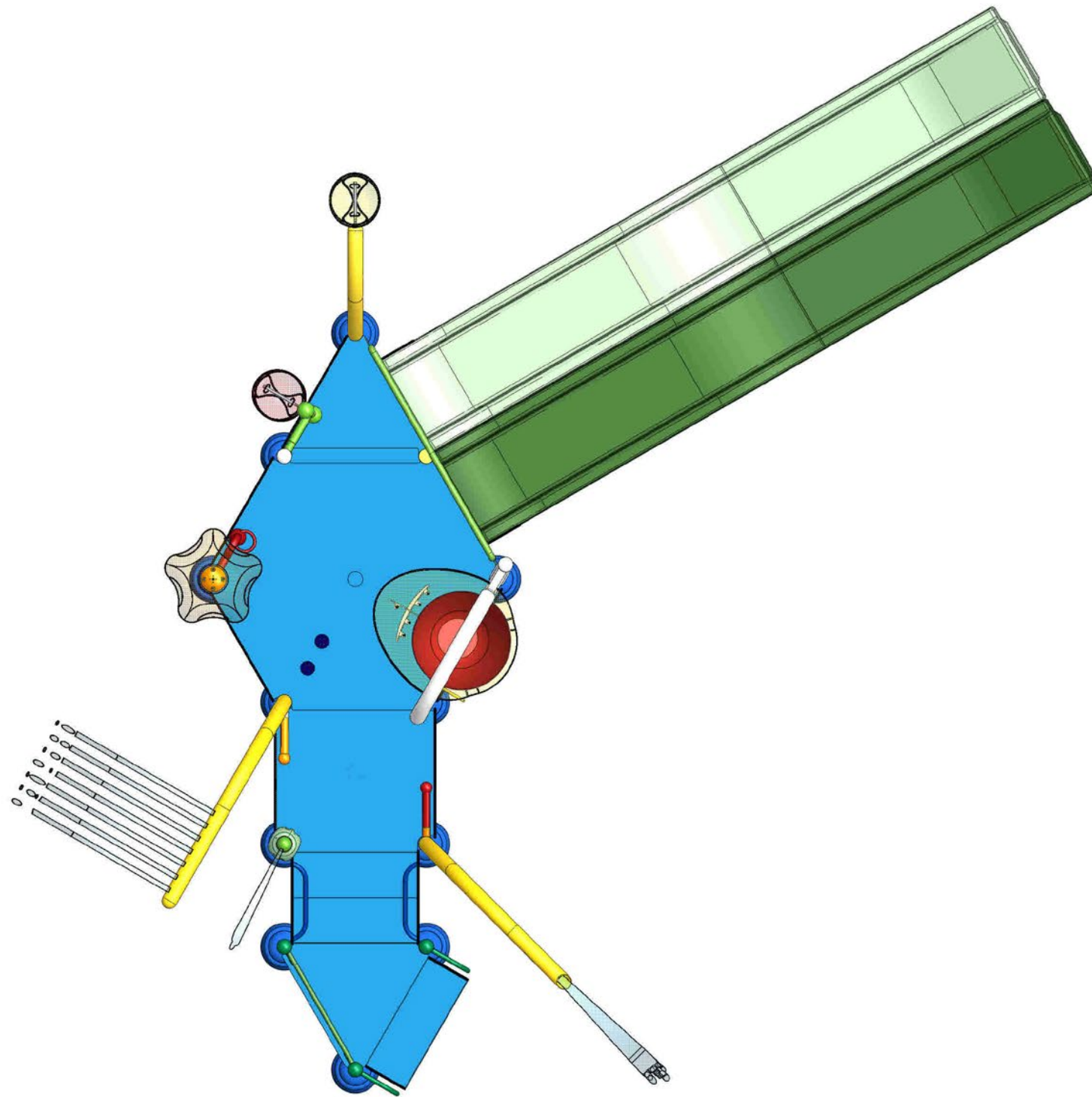

- 4 Decks on an iconic custom Elevation
- 13 Interactive water features with a variety of water effects
- 2 Waterslides. Parallel flumes promote race experiences
- 1 Iconic TwinSplash dumping feature
- ✓ Unique custom design
- ✓ Decorative elements with Seeflow™ technology creating colorful shadows
- ✓ Several cannons with different effects and play experiences
- ✓ ADA accessible entry

ELEVATIONS LEGEND

WATER ANCHORS = 2
DECKS = 4
WATER PLAY FEATURES= 13
WATERSLIDES = 2
TOTAL FLOW = 350 gpm (1325 lpm)
MAX USER CAPACITY = 110 users

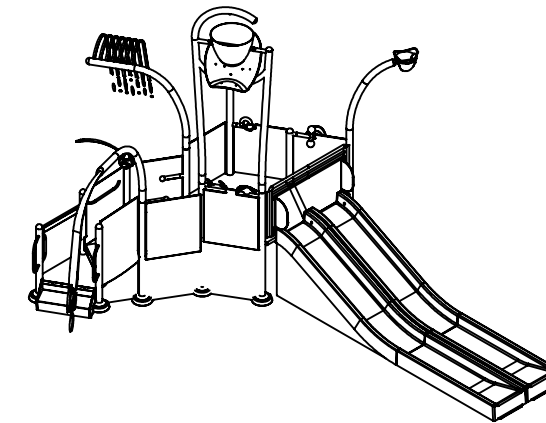
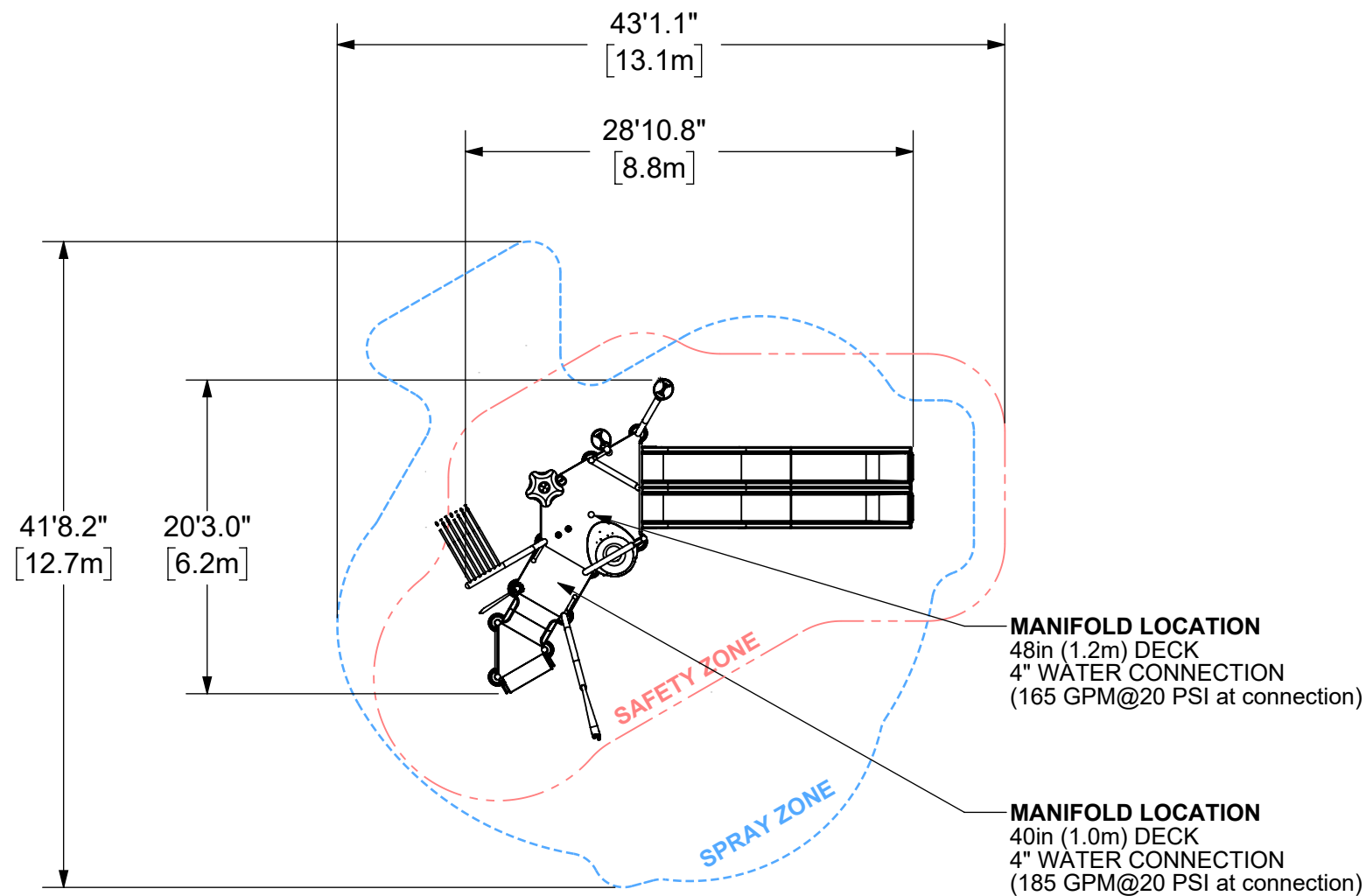

5' Spray-free buffer area is recommended around the structure

IMPORTANT

Client to provide Vortex with CAD and/or "As Built" drawings to establish the pool floor slope. If this is impossible, client will need to provide site dimensions that identify various depths at the Elevations structure location.

Failure to provide this information will cause delays in completing the submittal documents, fabrications drawings and may delay product delivery. Inaccurate information may cause additional site work at client's expense.

This proposal was made using PDF file: (S-191222- Crete Splash Pad-2-13-2020)

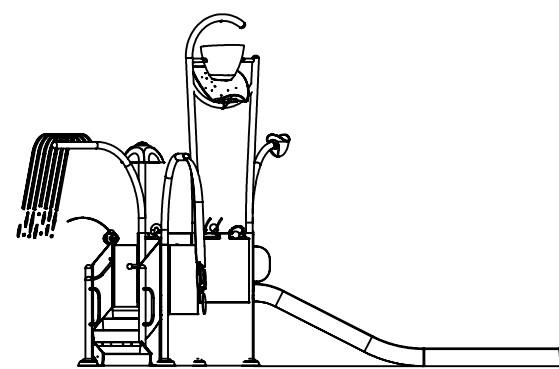

Minimum User Height for waterslides: 36" (0.90m)

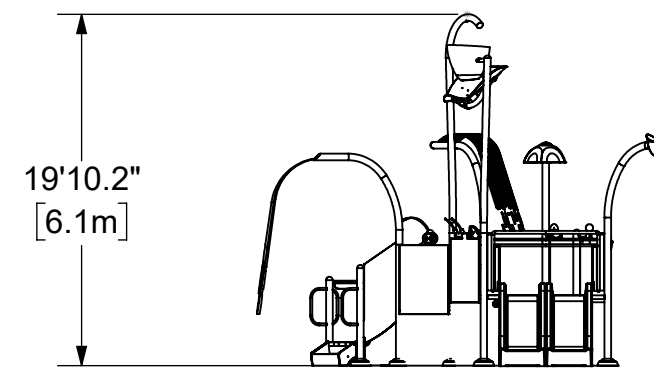

PRELIMINARY - NOT FOR CONSTRUCTION

THE DIMENSIONS CONTAINED HERE IN ARE A RESULT OF INITIAL SITE INFORMATION THAT WAS PROVIDED DURING THE PRELIMINARY DESIGN PROCESS. WHILE EVERY ATTEMPT HAS BEEN MADE TO ASSURE ACCURACY, FINAL CONSTRUCTION DRAWING DIMENSIONS MAY VARY.

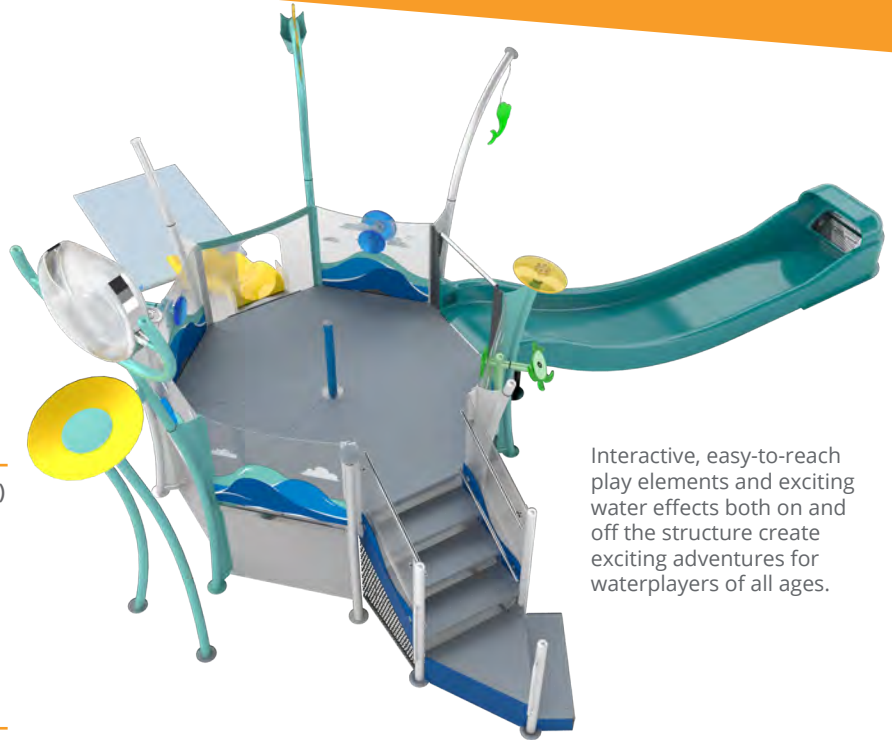
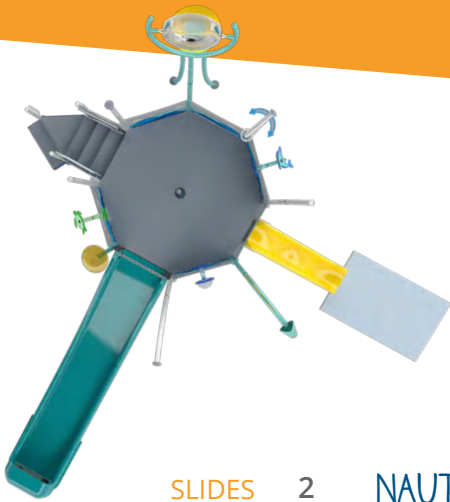

Interactive, easy-to-reach play elements and exciting water effects both on and off the structure create exciting adventures for waterplayers of all ages.

SLIDES 2 NAUTICAL

WATER FEATURES 13

LENGTH / WIDTH	35'5" x 33'5" (18.8m x 10.2m)
TOTAL HEIGHT	14'8" (4.51m)
ELEVATED PLAY AREA	90ft ² (8.4m ²)
DECK HEIGHT	4' (1.22m) OCTO
TOTAL WATER FLOW	264 GPM (999 LPM)

Stairs and transfer stations not included in elevated play area calculation. See Specification Sheet for product data.

DISCOVERY SERIES N150

0010-6322

PRODUCT LINE Activity Towers

CATEGORY Discovery Series

PLAY OPPORTUNITIES

A perfect setting to make new discoveries and engage in immersive play, the Discovery Series Signature Designs fit easily into any project. 4' (1.2m) deck heights invite fun for all ability levels.

SIGNATURE FEATURES



4' SINGLE WAVE FLUME
(0010-2084)



TURTLE PANEL SPLASHER
(0010-2801)



TOWER SOAKER
(0010-2015)

PLAY-BASED LEARNING



COGNITIVE



SOCIAL



PHYSICAL



CREATIVE

Play is fundamental in childhood development, health and wellbeing. Waterplay products are designed using research that supports cognitive, social and emotional, creative and physical growth. The above icons represent the leading attributes associated with this play feature.

PLAY ZONES

DEVELOPMENT

DISCOVERY

EXPLORATION

ADVENTURE

playCONNECT™

Detachable Feature Mounting System

INSTALLATION

Zero-depth/Wading Pool/Sloped Surfaces

- ✓ Inclusive Design
- ✓ ADA Accessible
- ✓ ASTM Safety Standards

waterplay® solutions corp.

1.800.590.5552 (USA & CAN) | +1 (250) 712.3393 (INTL)
info@waterplay.com | www.waterplay.com

LIST OF MATERIALS / LISTE DE MATÉRIAUX (IF / SI APPLICABLE)	
BASE MATERIAL / MATÉRIEL	304 STAINLESS STEEL / ACIER INOXYDABLE
NOZZLES / BUSES	ACETAL / ACÉTAL, URETHANE / URÉTHANE
PANELS / PANNEAUX	ACRYLIC / ACRYLIQUE, ALUMINUM / ALUMINIUM

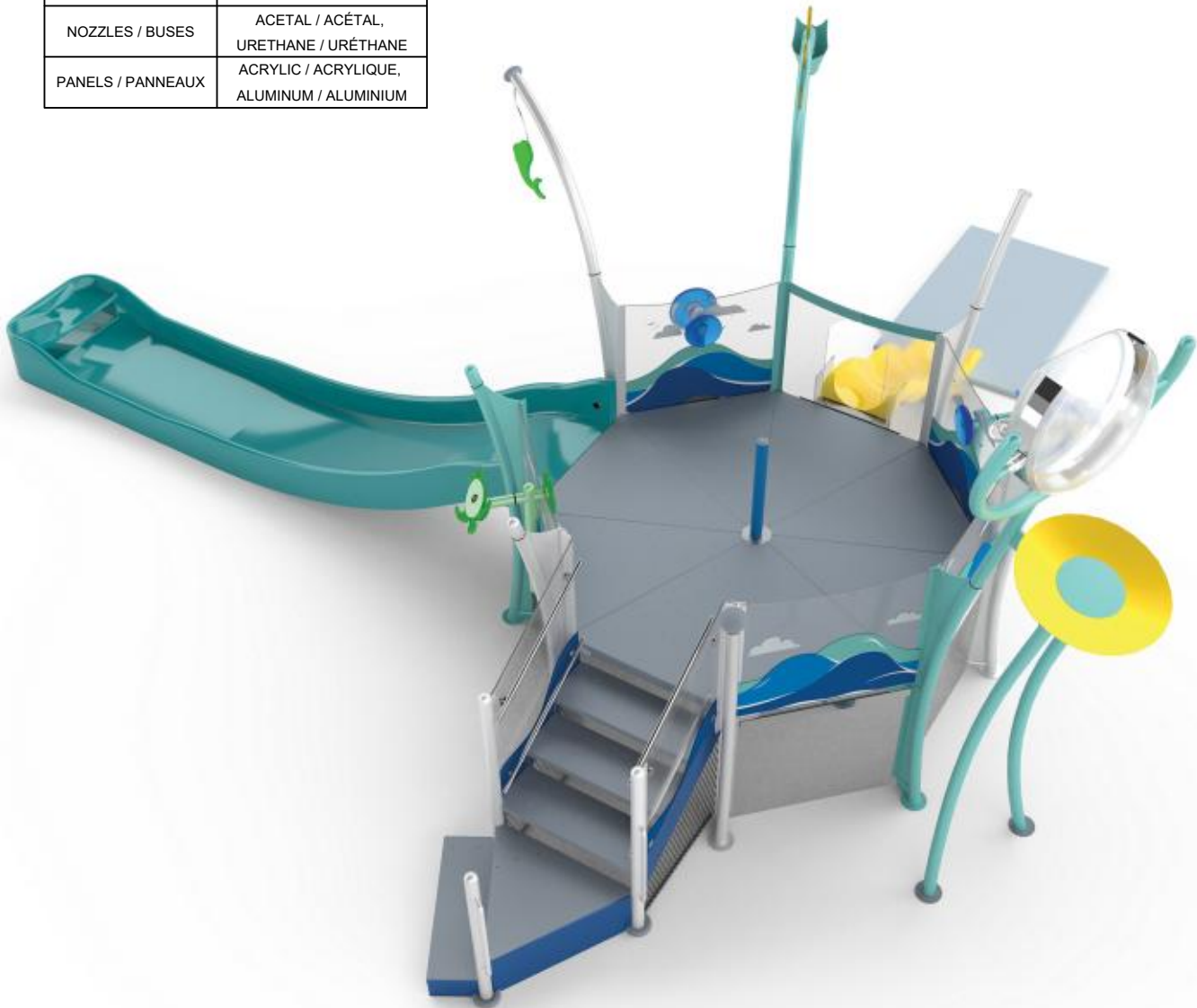

THIS RENDER IS AN ARTIST'S REPRESENTATION OF THE PRODUCT AND USES PANEL GRAPHICS AND COLOUR SELECTIONS THAT MAY DIFFER FROM THE FINAL PRODUCT. PANEL GRAPHICS (0010-6344) APPEAR SEPARATELY ON QUOTE.

CET IMAGE EST UNE REPRÉSENTATION ARTISTIQUE ET UTILISE DES GRAPHIQUES SUR LES PANNEAUX ET DES SÉLECTIONS DE COULEURS QUI PEUVENT DIFFÉRER DU PRODUIT FINAL. GRAPHIQUES DU PANNEAU (0010-6344) APPARAÎSSENT SÉPARÉMENT SUR LE DEVIS.

FOOTING BY OTHER, REFER TO LOCAL CODE / BASE DE BÉTON PAR D'AUTRES, SE RÉFÉRER AU CODE LOCAL

RECOMMENDED SPRAY AREA / ZONE D'ASPERSION POTENTIELLE			FLOW RATE / DÉBIT D'EAU		COMPONENT INCLUDES: (IF REQUIRED) / INCLUS AVEC LE JEU (SI REQUISE) -SERVICE TOOLS / OUTILS -SPRAY NOZZLES / BUSES DE PERFORMANCE	INITIAL:	
R (ft/mm)	L (ft/mm)	W (ft/mm)	GPM/LPM	PSI/kPa		DRAWING ID:	SHEET: 1
-/-	-/-	-/-	264/999	-/-	DIMENSIONAL ACCURACY / PRÉCISION DIMENSIONNELLE +/- 1" [25mm]	0010-6322	OF: 3
NOZZLES / BUSES			MASS:				



805 CROWLEY AVE.
KELOWNA, BRITISH COLUMBIA
CANADA, V1Y 7G6
P: 250-712-3393 F: 250-861-4814
E: design@waterplay.com W: waterplay.com

ALL PLANS AND DESIGNS AT ALL TIMES REMAIN THE PROPERTY OF THE WATERPLAY AND CANNOT BE USED OR REPRODUCED WITHOUT WRITTEN PERMISSION.

TOUS LES PLANS ET DESSINS QUE WATERPLAY ONT CONÇUS, LEUR APPARTIENNENT ET NE PEUVENT ÊTRE UTILISÉS OU REPRODUITS SANS AVOIR UNE PERMISSION ÉCRITE DE LEUR PART.

NOTE: REFER TO THE COMPONENT WRITTEN SPECIFICATION DOCUMENT FOR COMPLETE PRODUCT SPECIFICATIONS. WATERPLAY RESERVES THE RIGHT TO CHANGE THIS SPECIFICATION WITHOUT NOTICE.

SE RÉFÉRER AU DOCUMENT DE SPÉCIFICATION ÉCRIT POUR LES DÉTAILS COMPLET DU PRODUIT. WATERPLAY A LE DROIT DE CHANGER CES DERNIERS SANS PRÉAVIS.

PART ID	DESCRIPTION	QTY	PART ID	DESCRIPTION	QTY
0002-4930	SAFETY MAT, 60" X 96" X 2"	1	0010-2801	TURTLE-PS ASSY	1
0010-0485	FUNBRELLA INSTALL	1	0010-2930	ANCHOR CANNON ASSY	1
0010-0937	BOBBLE NOZZLE ASSY	1	0010-2943	WATER BROLLY ASSY	1
0010-1083	SUPPORT COLUMN WELD ASSY, 48" D.H	8	0010-2989	RAILING PANEL KIT	2
0010-2015	TOWER SOAKER ASSY 48" D.H	1	0010-3136	WATERNOOK ASSY, 4ft OCTO	2
0010-2041	COLUMN PLUG ASSY	2	0010-3244	ANGLED STAIR ASSY 48" LH	1
0010-2084	4' SP POLY WAVE FLUME ASSY	1	0010-3668	4' OCTODECK OUTER COLUMN JIG	1
0010-2103	4' OCTODECK NETTING KIT	5	0010-3713	PLAY POD 4FT - OCTO	1
0010-2351	FISHIN' POLE ASSY	1	0010-4005	WHIRLWIND ASSY	1
0010-2362	OGO ASSY	1	0010-4568	4' ANGLED STAIR NETTING KIT OCTO	1
0010-2798	BEACH BALL-PS ASSY	1	0010-6393	AT FLUME 4 ft CLOSED RUNOUT WMI	1
0010-2799	DOLPHIN-PS ASSY	1			

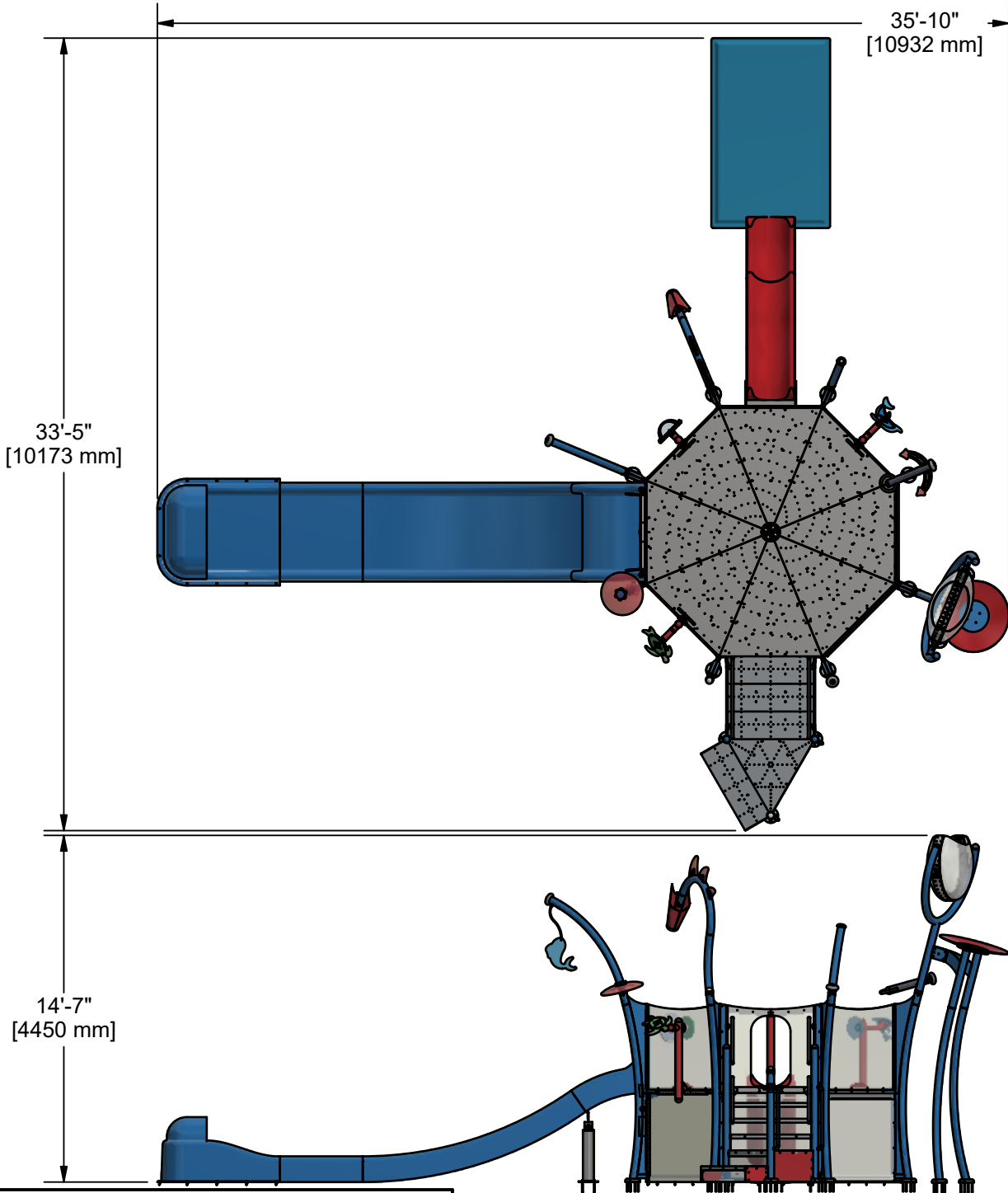

805 CROWLEY AVE.
 KELOWNA, BRITISH COLUMBIA
 CANADA, V1Y 2A3
 P: 250-712-3393 F: 250-861-4814
 E: design@waterplay.com W: waterplay.com

DRAWING ID: **0010-6322** SHEET: 2
 OF: 3

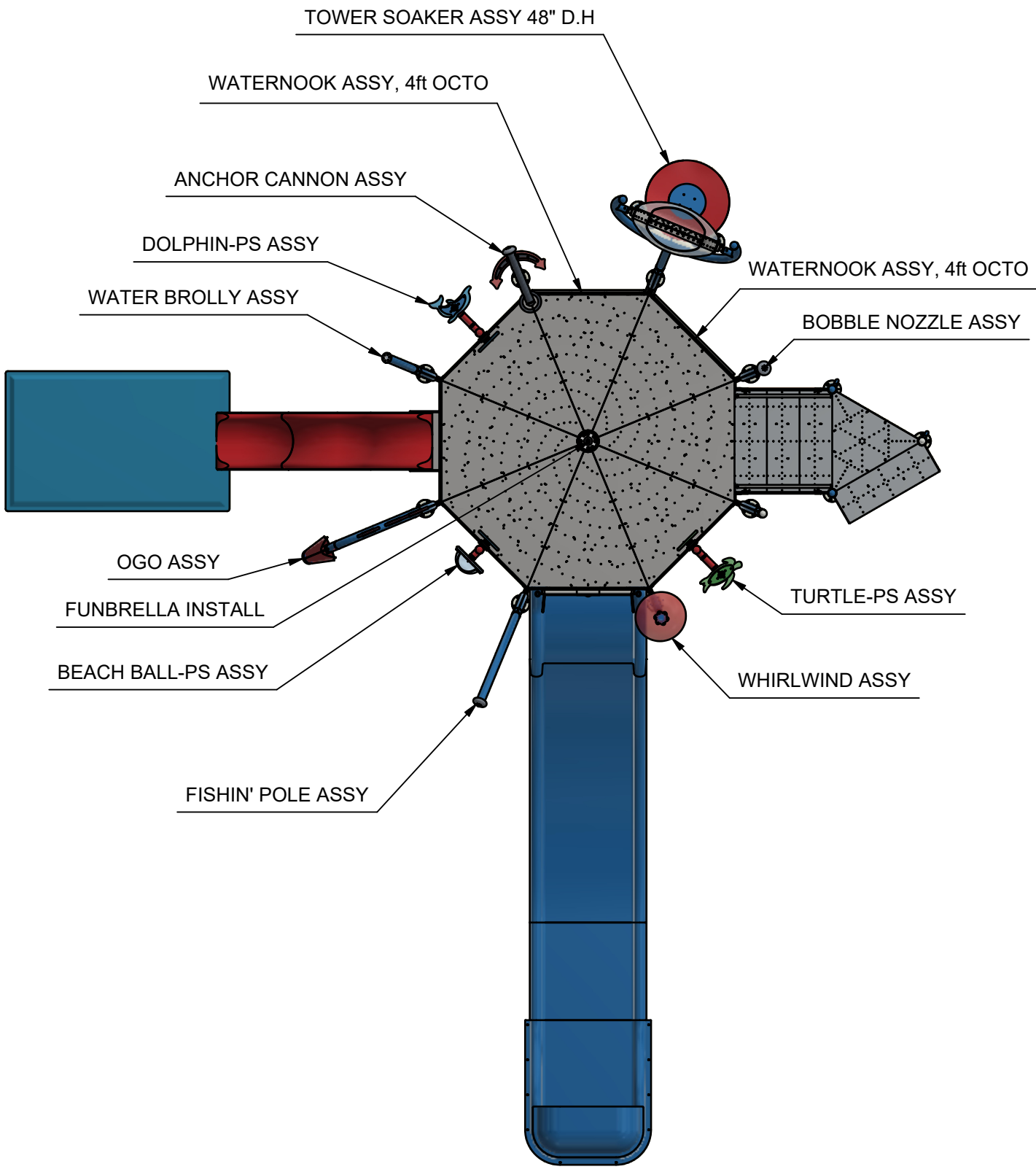

TOWER SOAKER ASSY 48" D.H

WATERNOOK ASSY, 4ft OCTO

ANCHOR CANNON ASSY

DOLPHIN-PS ASSY

WATER BROLLY ASSY

WATERNOOK ASSY, 4ft OCTO

BOBBLE NOZZLE ASSY

OGO ASSY

FUNBRELLA INSTALL

BEACH BALL-PS ASSY

TURTLE-PS ASSY

WHIRLWIND ASSY

FISHIN' POLE ASSY



805 CROWLEY AVE.
 KELOWNA, BRITISH COLUMBIA
 CANADA, V1Y 2A3
 P: 250-712-3393 F: 250-861-4814
 E: design@waterplay.com W: waterplay.com

DRAWING ID:	0010-6322	SHEET: 3
		OF: 3

**NOT FOR CONSTRUCTION
PURPOSES**

NOTES:

1. MAIN AQUATIC PLAY PAD AREA: 2224 SQ
TOTAL AREA, INCLUDING OVERSPRAY ZONE: 2819 SQ
2. TO AVOID POTENTIAL DAMAGE TO SURROUNDING SOFTSCAPE AND TO KEEP PEDESTRIAN TRAFFIC FROM GETTING WET, WATERPLAY RECOMMENDS A MINIMUM OVERSPRAY OF 2.44 METRES (8'). FOR AREAS WITH HIGH WINDS, A LARGER OVERSPRAY ZONE MAY BE REQUIRED.
3. GRADE SURROUNDING OUTSIDE PERIMETER LANDSCAPE TO PROVIDE ADDITIONAL DRAINAGE AWAY FROM OVERSPRAY PAD.
4. SLOPES (INCLUDING MAIN AND OVERSPRAY AREAS) TO PROVIDE POSITIVE DRAINAGE TO DRAINS. IF CODE REQUIRES THAT THERE BE A ZONE SLOPING AWAY FROM THE MAIN AREA, WATERPLAY RECOMMENDS AN ADDITIONAL DRY ZONE TO MEET THAT REQUIREMENT.
5. SLAB GRADES SUBJECT TO ENGINEER APPROVAL (NOTE ADA MAX CROSS SLOPE GRADE IS 2%).

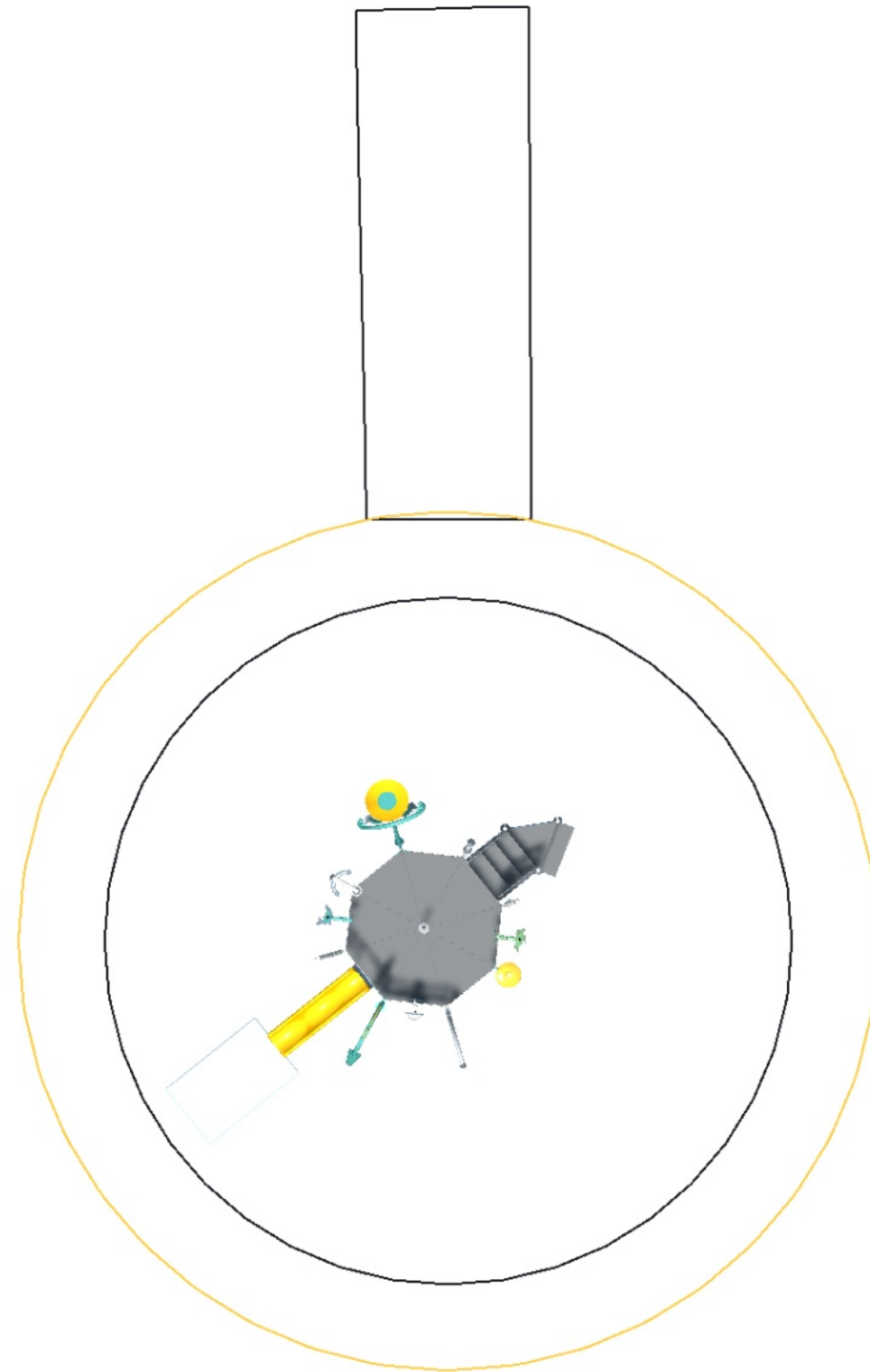

IMPERIAL

60 x 95

FOR INFORMATIONAL PURPOSES ONLY.
LOCAL
LANDSCAPE ARCHITECT, ENGINEER AND/OR
APPROPRIATE AUTHORITIES HAVING
JURISDICTION MUST COMPLETE ALL PARK
LAYOUT, MECHANICAL & ELECTRICAL
DESIGN PRIOR TO CONSTRUCTION.

DESIGNED IN:

WATERPLAY INTERACTIVE

DESIGNED BY:

**Waterplay Solutions
Corp.**

1:291

2021-03-17

**Wildwood Pool Play Structure,
Crete, NE**



805 Avenue, Kelowna BC
Canada V1Y 7G6
TEL. (250) 712-3393 FAX (250) 861-4814

info@waterplay.com

IMPERIAL

12 x 36

FOR INFORMATIONAL PURPOSES ONLY.
LOCAL
LANDSCAPE ARCHITECT, ENGINEER AND/OR
APPROPRIATE AUTHORITIES HAVING
JURISDICTION MUST COMPLETE ALL PARK
LAYOUT, MECHANICAL & ELECTRICAL
DESIGN PRIOR TO CONSTRUCTION.

DESIGNED IN:
WATERPLAY INTERACTIVE

DESIGNED BY:
Waterplay Solutions
~~Waterplay Solutions~~
Corp.

1:291

2021-03-17

Wildwood Pool Play Structure,
Crete, NE



805 Avenue, Kelowna BC
Canada V1Y 7G6
TEL. (250) 712-3393 FAX (250) 861-4814

info@waterplay.com

**NOT FOR CONSTRUCTION
PURPOSES**

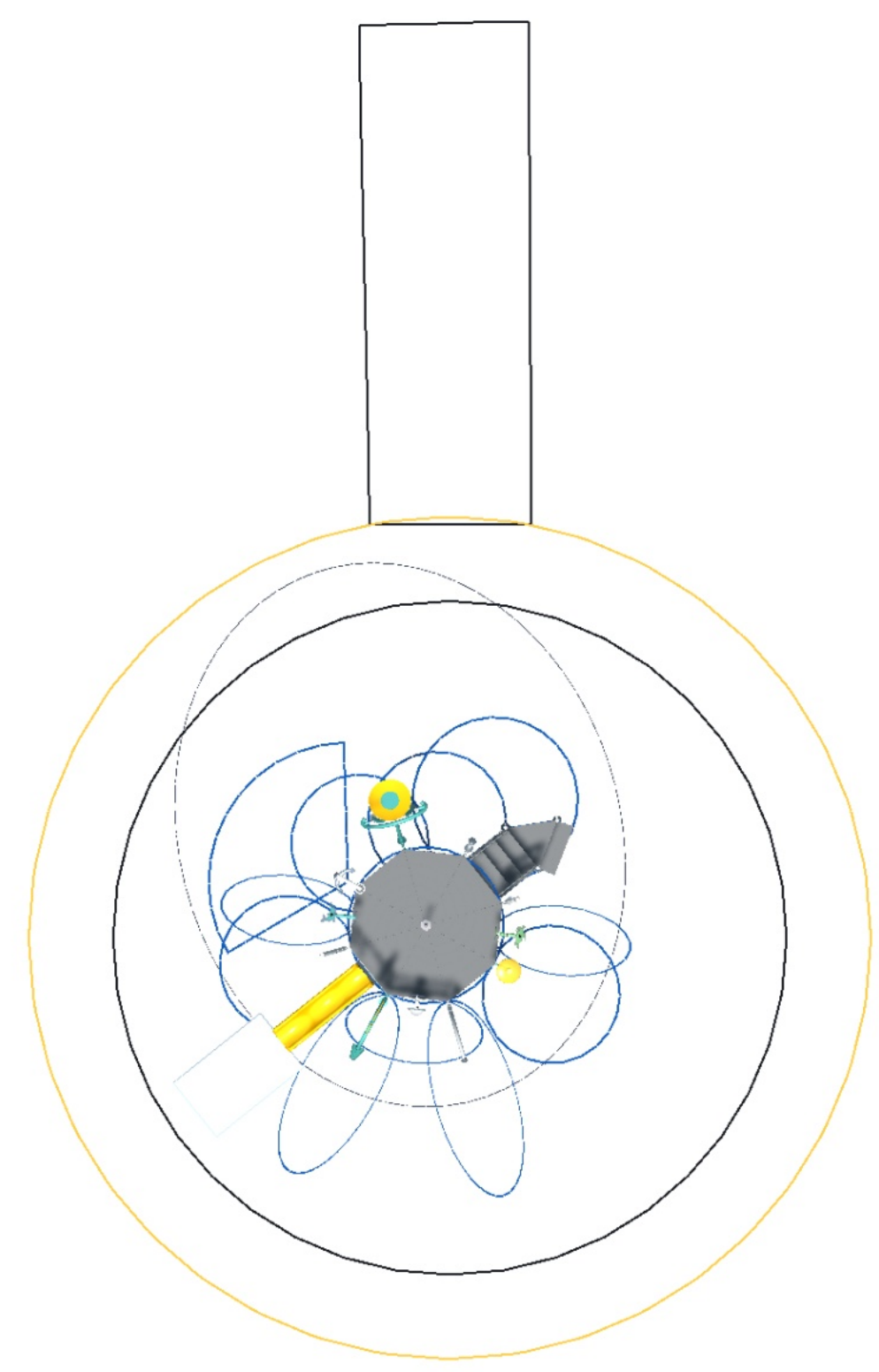

CODE	SKU	COMPONENT NAME	QTY
1	0010-6322	Discovery Series N150	1

IMPERIAL

60 x 60

FOR INFORMATIONAL PURPOSES ONLY.
 LOCAL
 LANDSCAPE ARCHITECT, ENGINEER AND/OR
 APPROPRIATE AUTHORITIES HAVING
 JURISDICTION MUST COMPLETE ALL PARK
 LAYOUT, MECHANICAL & ELECTRICAL
 DESIGN PRIOR TO CONSTRUCTION.

DESIGNED IN:

WATERPLAY INTERACTIVE

DESIGNED BY:

Waterplay Solutions
 Corp.
 Waterplay Solutions
 Corp.

1:152

2021-03-17

**NOT FOR CONSTRUCTION
 PURPOSES**

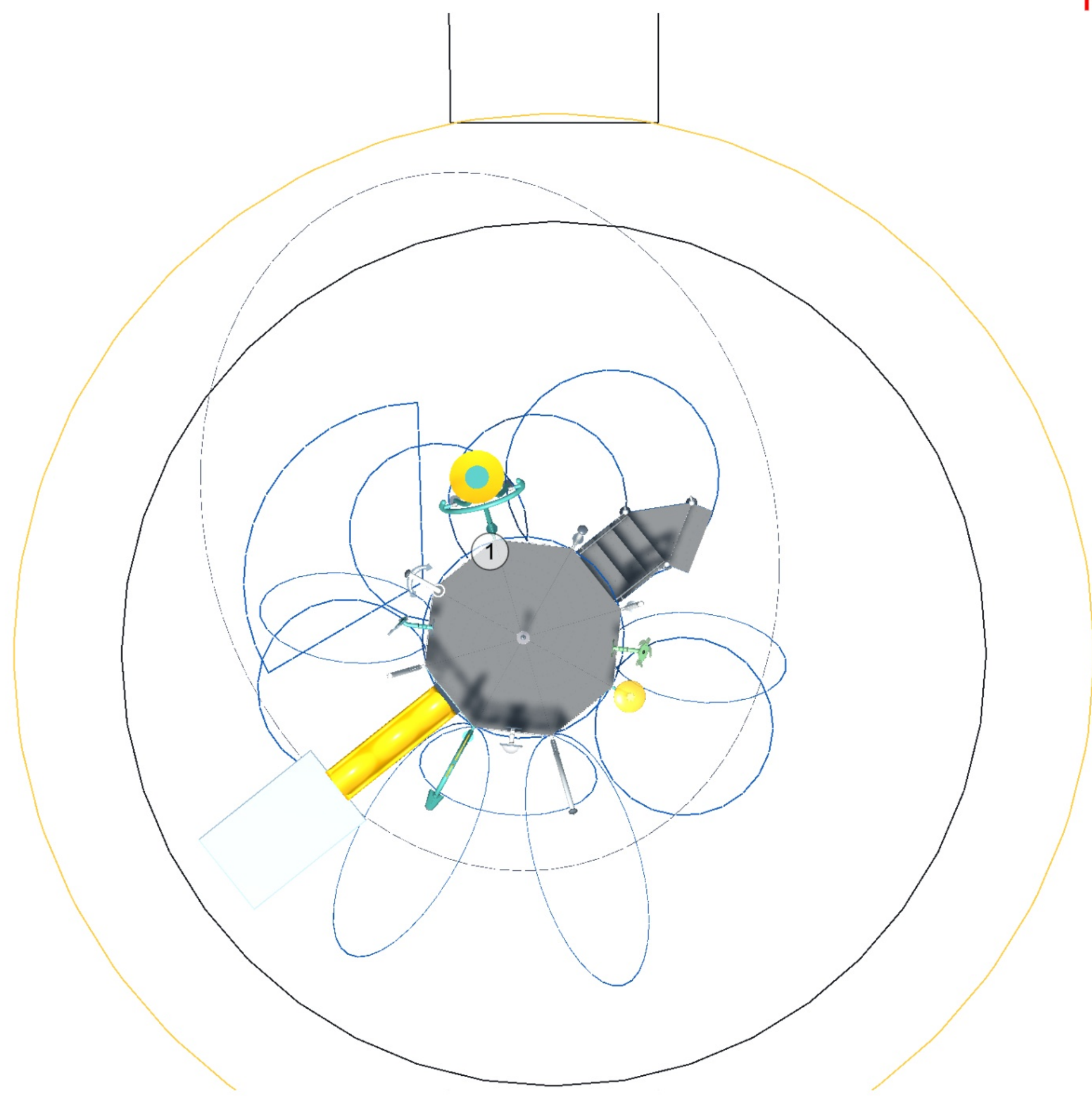

Wildwood Pool Play Structure,
 Crete, NE



805 Avenue, Kelowna BC
 Canada V1Y 7G6
 TEL. (250) 712-3393 FAX (250) 861-4814

info@waterplay.com

**NOT FOR CONSTRUCTION
PURPOSES**

NOTES:

1. MAIN AQUATIC PLAY PAD AREA: 422 SQ
TOTAL AREA, INCLUDING OVERSPRAY ZONE: 0 SQ
2. TO AVOID POTENTIAL DAMAGE TO SURROUNDING SOFTSCAPE AND TO KEEP PEDESTRIAN TRAFFIC FROM GETTING WET, WATERPLAY RECOMMENDS A MINIMUM OVERSPRAY OF 2.44 METRES (8'). FOR AREAS WITH HIGH WINDS, A LARGER OVERSPRAY ZONE MAY BE REQUIRED.
3. GRADE SURROUNDING OUTSIDE PERIMETER LANDSCAPE TO PROVIDE ADDITIONAL DRAINAGE AWAY FROM OVERSPRAY PAD.
4. SLOPES (INCLUDING MAIN AND OVERSPRAY AREAS) TO PROVIDE POSITIVE DRAINAGE TO DRAINS. IF CODE REQUIRES THAT THERE BE A ZONE SLOPING AWAY FROM THE MAIN AREA, WATERPLAY RECOMMENDS AN ADDITIONAL DRY ZONE TO MEET THAT REQUIREMENT.
5. SLAB GRADES SUBJECT TO ENGINEER APPROVAL (NOTE ADA MAX CROSS SLOPE GRADE IS 2%).

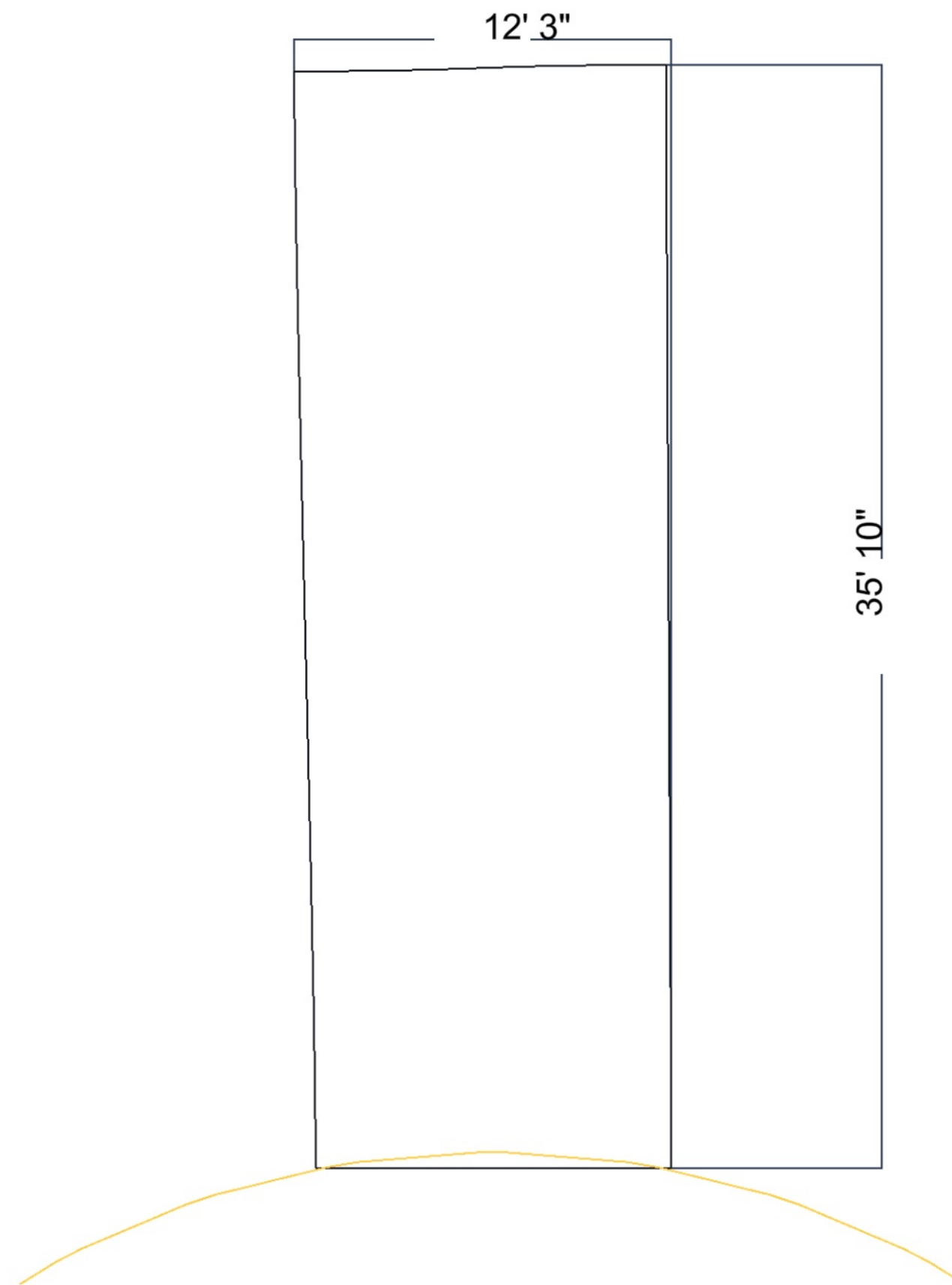

IMPERIAL

12 x 36

FOR INFORMATIONAL PURPOSES ONLY.
LOCAL
LANDSCAPE ARCHITECT, ENGINEER AND/OR
APPROPRIATE AUTHORITIES HAVING
JURISDICTION MUST COMPLETE ALL PARK
LAYOUT, MECHANICAL & ELECTRICAL
DESIGN PRIOR TO CONSTRUCTION.

DESIGNED IN:

WATERPLAY INTERACTIVE

DESIGNED BY:

**Waterplay Solutions
Corp.**

1:112

2021-03-17

**Wildwood Pool Play Structure,
Crete, NE**



805 Avenue, Kelowna BC
Canada V1Y 7G6
TEL. (250) 712-3393 FAX (250) 861-4814

info@waterplay.com

**NOT FOR CONSTRUCTION
PURPOSES**

NOTES:

1. MAIN AQUATIC PLAY PAD AREA: 1803 SQ
TOTAL AREA, INCLUDING OVERSPRAY ZONE: 2819 SQ
2. TO AVOID POTENTIAL DAMAGE TO SURROUNDING SOFTSCAPE AND TO KEEP PEDESTRIAN TRAFFIC FROM GETTING WET, WATERPLAY RECOMMENDS A MINIMUM OVERSPRAY OF 2.44 METRES (8'). FOR AREAS WITH HIGH WINDS, A LARGER OVERSPRAY ZONE MAY BE REQUIRED.
3. GRADE SURROUNDING OUTSIDE PERIMETER LANDSCAPE TO PROVIDE ADDITIONAL DRAINAGE AWAY FROM OVERSPRAY PAD.
4. SLOPES (INCLUDING MAIN AND OVERSPRAY AREAS) TO PROVIDE POSITIVE DRAINAGE TO DRAINS. IF CODE REQUIRES THAT THERE BE A ZONE SLOPING AWAY FROM THE MAIN AREA, WATERPLAY RECOMMENDS AN ADDITIONAL DRY ZONE TO MEET THAT REQUIREMENT.
5. SLAB GRADES SUBJECT TO ENGINEER APPROVAL (NOTE ADA MAX CROSS SLOPE GRADE IS 2%).

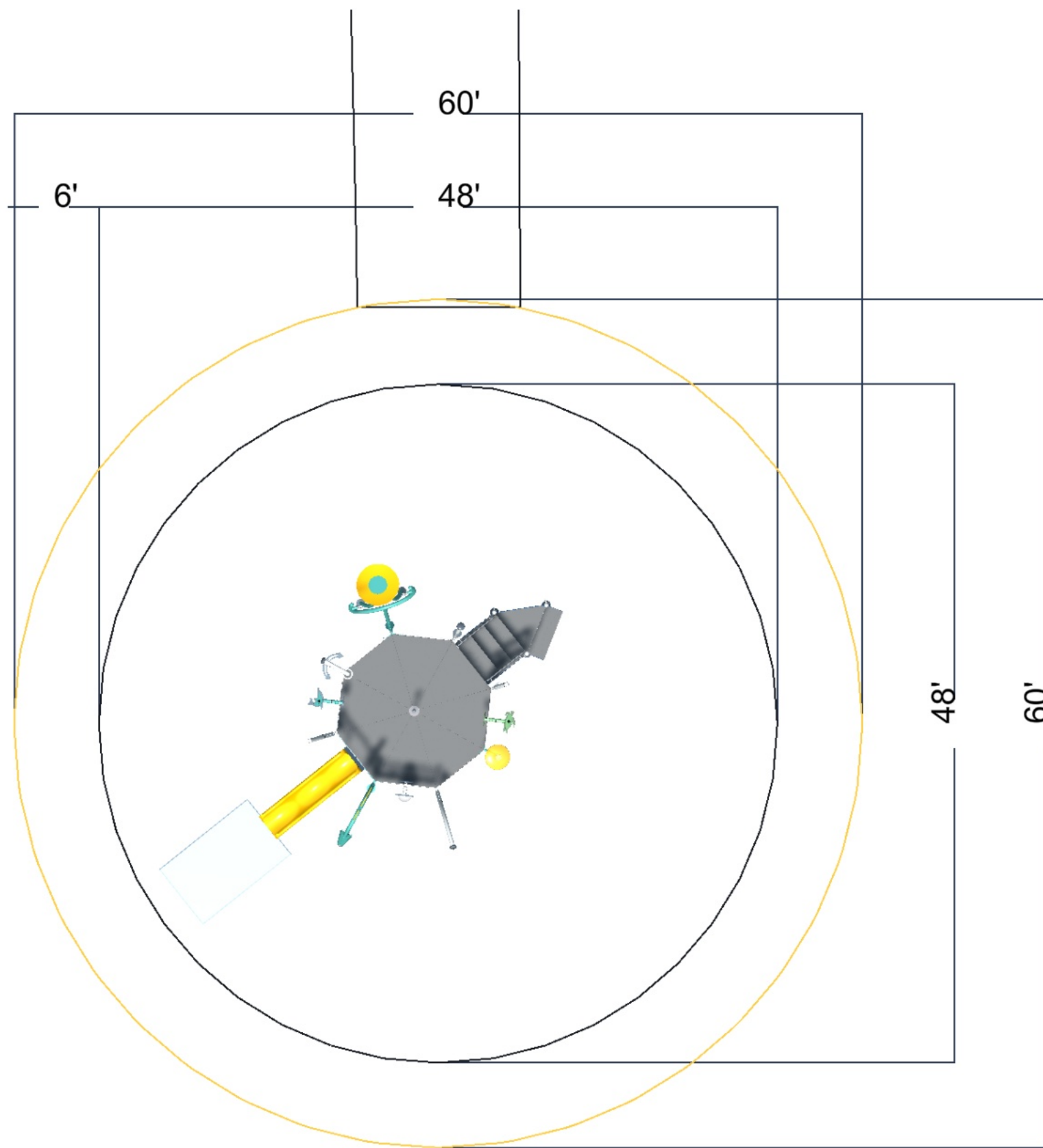

IMPERIAL

60 x 60

FOR INFORMATIONAL PURPOSES ONLY.
LOCAL
LANDSCAPE ARCHITECT, ENGINEER AND/OR
APPROPRIATE AUTHORITIES HAVING
JURISDICTION MUST COMPLETE ALL PARK
LAYOUT, MECHANICAL & ELECTRICAL
DESIGN PRIOR TO CONSTRUCTION.

DESIGNED IN:

WATERPLAY INTERACTIVE

DESIGNED BY:

**Waterplay Solutions
Corp.**

1:223

2021-03-17

**Wildwood Pool Play Structure,
Crete, NE**



805 Avenue, Kelowna BC
Canada V1Y 7G6
TEL. (250) 712-3393 FAX (250) 861-4814

info@waterplay.com

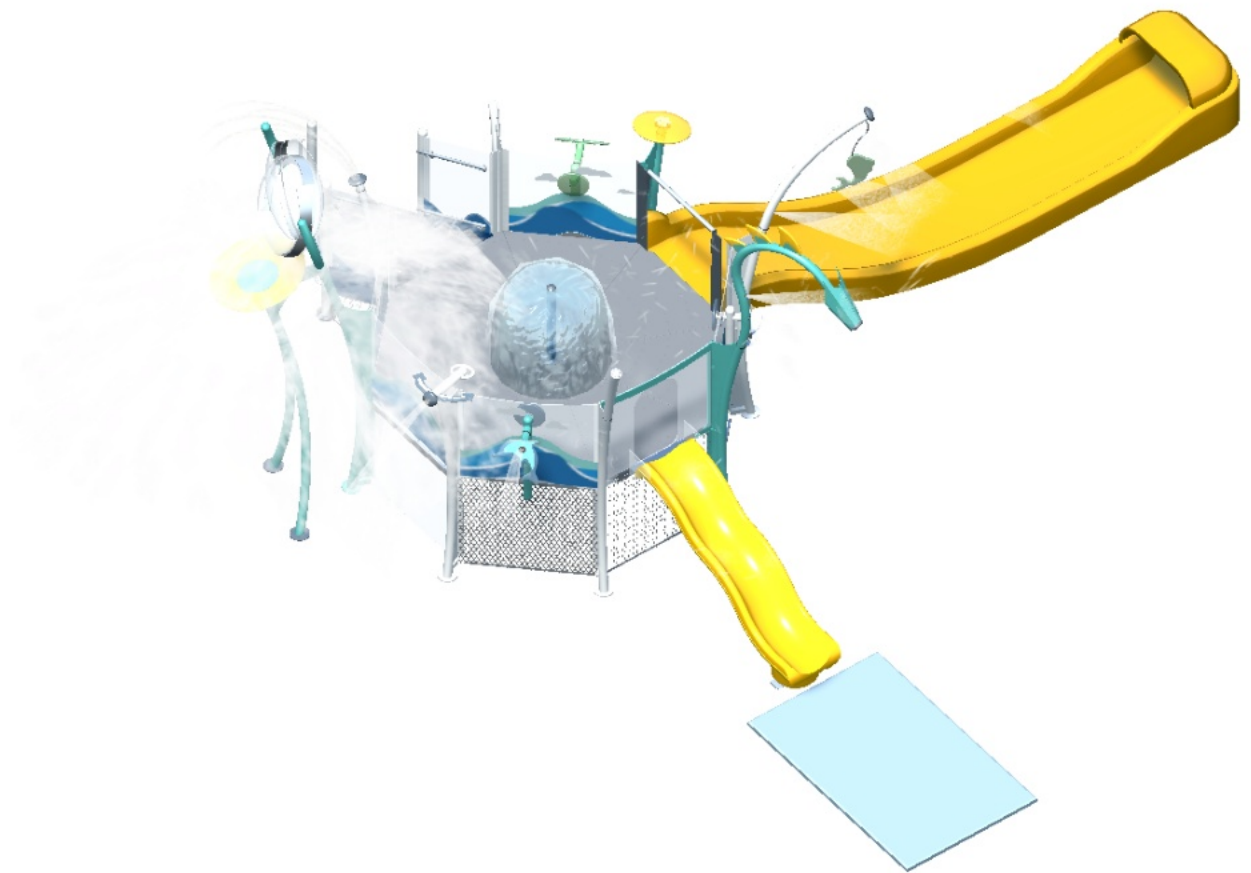

805 Avenue, Kelowna BC
 Canada V1Y 7G6
 P: 250-712-3393 F: 250-861-4814
 E: info@waterplay.com W: waterplay.com

ALL PLANS AND DESIGNS AT ALL TIMES REMAIN THE PROPERTY OF THE WATERPLAY AND CANNOT BE USED OR REPRODUCED WITHOUT WRITTEN PERMISSION.

TOUT LES PLANS ET DESSINS QUE WATERPLAY ONT CONÇUS, LEURS APPARTIENNENT ET NE PEUVENT ÊTRE UTILISÉS OU REPRODUITS SANS AVOIR UNE PERMISSION ÉCRITE DE LEUR PART.

NOTE: REFER TO THE COMPONENT WRITTEN SPECIFICATION DOCUMENT FOR COMPLETE PRODUCT SPECIFICATIONS. WATERPLAY RESERVES THE RIGHT TO CHANGE THIS SPECIFICATIONS WITHOUT NOTICE.

REFÉREZ-VOUS AU DOCUMENT DE SPÉCIFICATION ÉCRIT POUR LES DÉTAILS COMPLET DU PRODUIT. WATERPLAY A LE DROIT DE CHANGER CES DERNIERS SANS PRÉAVIS.

PART ID	COMPONENT NAME	QTY	PART ID	COMPONENT NAME	QTY
0010-3668	4 OCTODECK OUTER COLUMN JIG	1	0010-2362	AT OGO	1
0010-3713	AT 4 FT OCT POD	1	0010-2799	AT PS DOLPHIN	1
0010-2015	AT 48IN TOWER SOAKER	1	0010-2903	AT PS SPLASHER	1
0010-2211	AT 4FT H NETTING PANELS	2	0010-2801	AT PS TURTLE	1
0010-4568	AT 4FT O ANGLED STAIR NETTING	1	0010-2989	AT RAILING PANEL KIT	2
0010-2103	AT 4FT O NETTING PANELS	3	0002-4930	AT SAFETY MAT 60IN X 96IN X 2	1
0010-3136	AT 4FT WATERNOOK OCT	2	0010-1083	AT SUPPORT COLUMN 48IN CURVED	8
0010-2930	AT ANCHOR CANNON	1	0010-2943	AT WATER BROLLY	1
0010-3244	AT ANGLED STAIR 48IN LH	1	0010-4005	AT WHIRLWIND	1
0010-0937	AT BOBBLE NOZZLE	1	0010-0485	FS FUN-BRELLA	1
0010-2041	AT COLUMN PLUG	2	0010-5728	Graphic Panel - Upcharge	7
0010-2351	AT FISHIN' POLE	1			
0010-6393	AT FLUME 4 FT WMI	1			
0010-2084	AT FLUME 4FT SP WAVE FLUME	1			

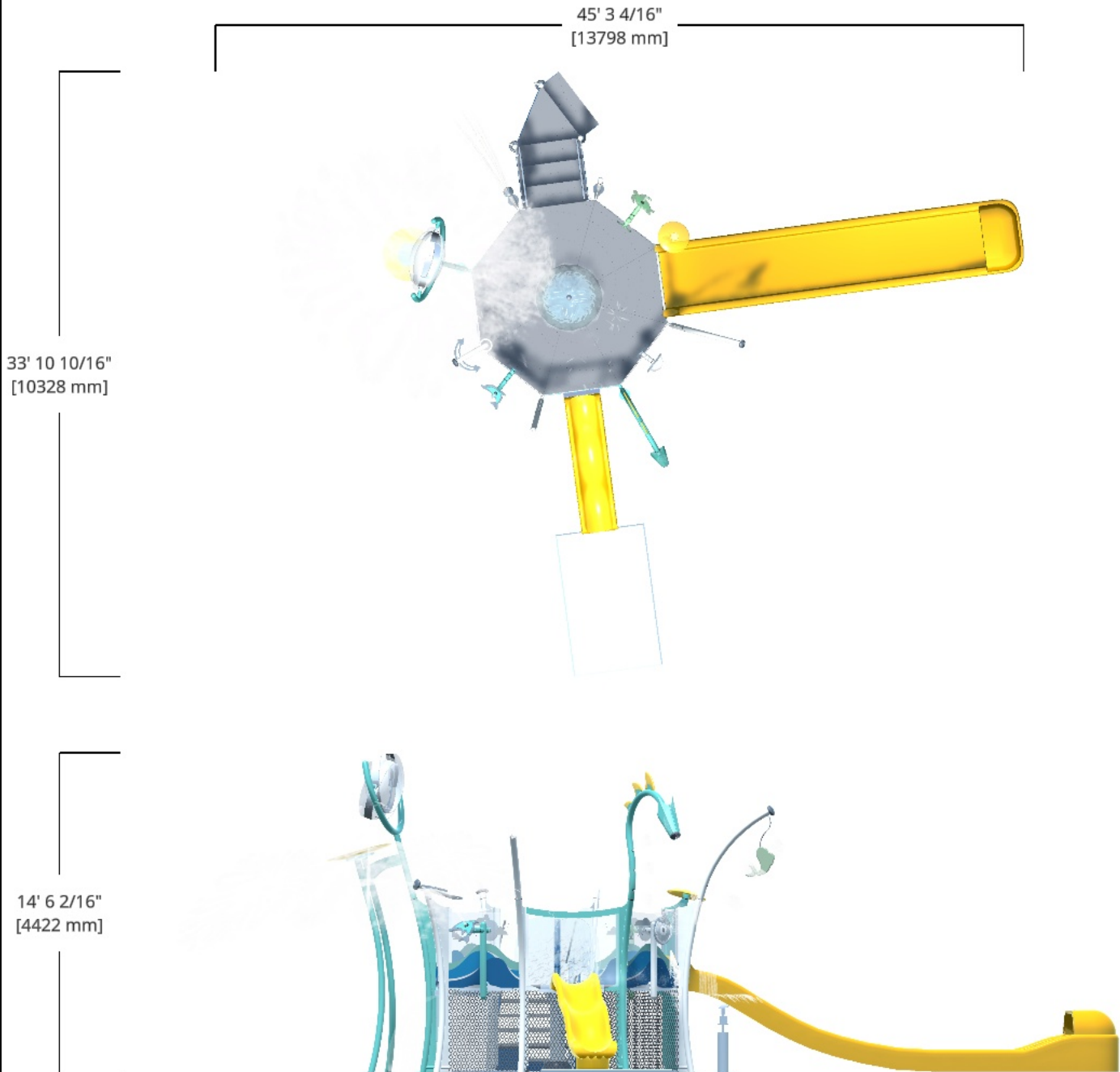



Wildwood Pool Play Structure, Crete, NE

Copyright 2019 Waterplay Solutions Corp. Artist's visual interpretation of the project. Cannot be considered a factual representation of the final product.



Wildwood Pool Play Structure, Crete, NE

Copyright 2019 Waterplay Solutions Corp. Artist's visual interpretation of the project. Cannot be considered a factual representation of the final product.



Wildwood Pool Play Structure, Crete, NE

Copyright 2019 Waterplay Solutions Corp. Artist's visual interpretation of the project. Cannot be considered a factual representation of the final product.



Wildwood Pool Play Structure, Crete, NE

Copyright 2019 Waterplay Solutions Corp. Artist's visual interpretation of the project. Cannot be considered a factual representation of the final product.



Wildwood Pool Play Structure, Crete, NE

Copyright 2019 Waterplay Solutions Corp. Artist's visual interpretation of the project. Cannot be considered a factual representation of the final product.

April 16, 2021

Mr. Tom Ourada
City Administrator
City of Crete
243 East 13th Street
Crete, NE 68333

RE: Fairway Development 1st Addition
Crete, NE
REGA Project No. 181290

Mr. Ourada,

I hereby certify that the project has been constructed in substantial conformance to the approved plans. As-built plans drawings, construction observation and testing reports were sent to the City of Crete on February 17th, 2021. In addition, a dropbox link was sent to city staff for easy access.

The developer's one-year warranty period began March 26th, 2021. An 11-month walk-thru will be conducted to review the installed infrastructure in 2022.

Please do not hesitate to contact me with any questions.

Sincerely,



Nathaniel Burnett, PE
REGA Engineering Group, Inc.

Cc: Ron Sack



April 16, 2021

Ref: 226.000

Mr. Tom Ourada, City Administrator
City of Crete
PO Box 86
Crete, NE
68333-0086

Fairway Development 1st Addition – City of Crete

The Project Engineer has certified that the project has been constructed in accordance with the approved plans and specifications, as well as the required testing requirements for the City. City officials have conducted a final inspection of the project with the Project Engineer and no items were observed that required correction.

It is our recommendation that the City accept the Fairway Development 1st Addition. The acceptance by the City does not waive the 1-year warranty requirement of the Developer to repair any deficiencies that may result during the warranty period. We further recommend that the City have an 11-month walk through to determine if any corrective work will need to be performed by the Developer prior to the termination of the warranty period.

Sincerely,

Keith L. Gilmore, P.E.
Gilmore & Associates, Inc.

KLG:va

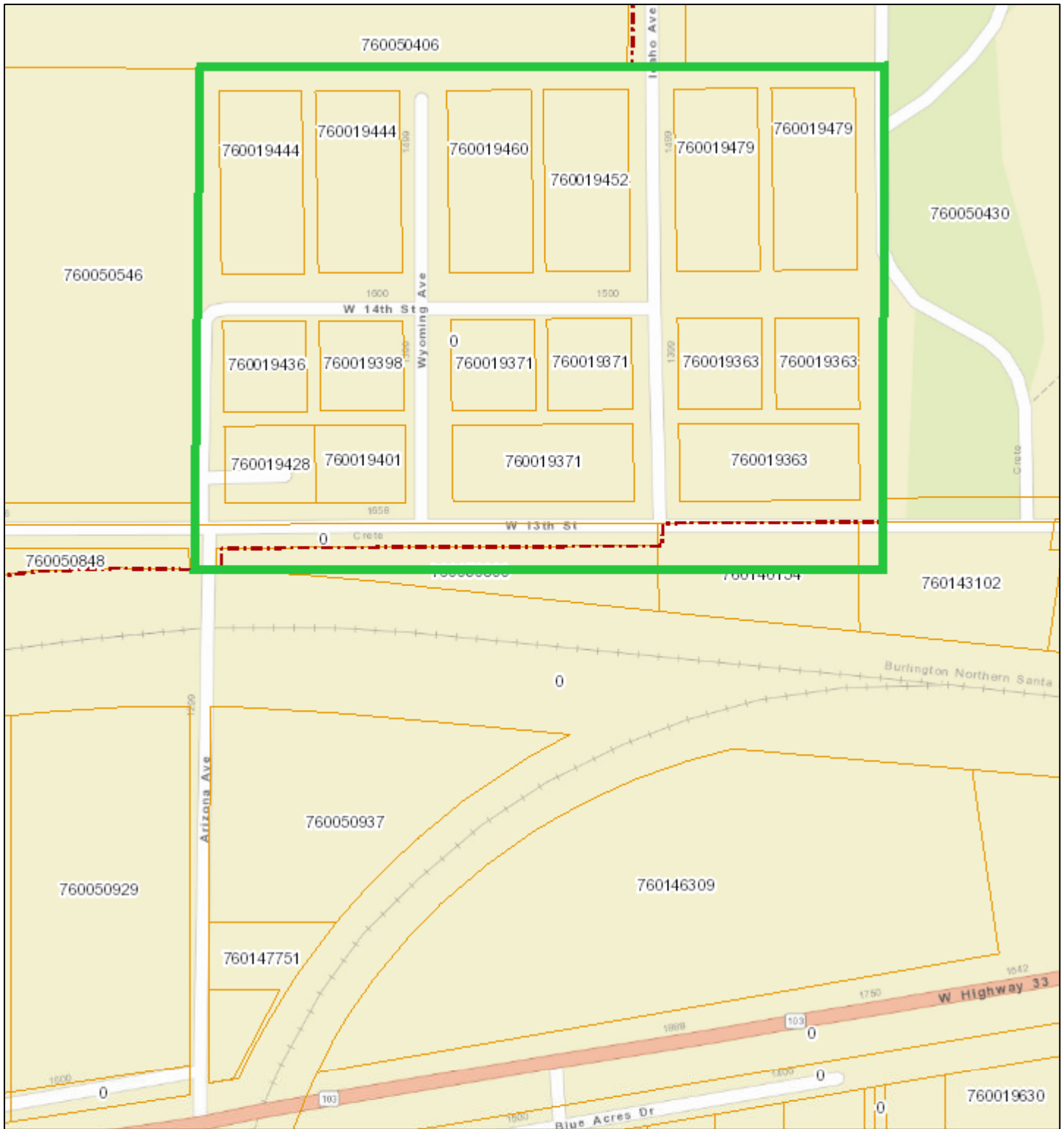



April 19, 2021

DISCLAIMER: This map is not intended for conveyances, nor is it a legal survey. The information is presented on a best-efforts basis, and should not be relied upon for making financial, survey, legal or other commitments.

Legend

1:3,261

-  Corp Limits
-  Parcels

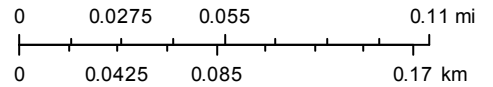

Sources: Esri, HERE, Garmin, USGS, Intermap, INCREMENT P, NRCan, Esri Japan, METI, Esri China (Hong Kong), Esri Korea, Esri (Thailand), NGCC, (c) OpenStreetMap contributors, and the GIS User Community

RESOLUTION NO. 2021-03

A RESOLUTION OF THE CITY OF CRETE, NEBRASKA PROPOSING THE ANNEXATION OF WEST CRETE ADDITION AND PROVIDING A PLAN FOR EXTENDING CITY SERVICES TO THE AREA.

WHEREAS, West Crete Addition is platted and subdivided land that is contiguous or adjacent to the City's corporate limits and urban or suburban in character;

WHEREAS, failing on-site septic systems at many properties within West Crete Addition have created a situation that is harmful to its residents' health and wellbeing and has led to administrative sanctions by the State of Nebraska;

WHEREAS, the configuration and size of the parcels and lots in West Crete Addition makes it impossible for the property owners to replace the failing on-site septic systems in a safe, sanitary, and lawful manner; and,

WHEREAS, the City has determined it is in the residents' best interests for the City to annex West Crete Addition into the City's corporate limits and provide water and sewer service to the properties located therein.

NOW, THEREFORE, BE IT RESOLVED BY THE MAYOR AND CITY COUNCIL OF THE CITY OF CRETE, NEBRASKA:

Section 1. That the City proposes to annex all of the properties located within West Crete Addition, which is within the borders of and includes Fifteenth Street to the north, Thirteenth Street to the south, Riverside Cemetery to the east, and Arizona Avenue to the west and which generally includes all of the lots located in Blocks 1, 2, 3, 4, 5, and 6 of West Crete Addition, Saline County, Nebraska.

Section 2. That the City's plan for the extension of city services to the area proposed for annexation shall be available for inspection during regular business hours in the City Clerk's Office.

Section 3. That a public hearing on the proposed annexation shall be held during the City Council's regular meeting on May 18, 2021 at 6:00 p.m. in City Hall to allow the City Council to receive testimony from interested persons.

PASSED AND ADOPTED this 20th day of April 2021.

Mayor

ATTEST:

City Clerk

Crete west 13th Annexation Sewer

Description	UNIT	Total	Unit Price	TOTAL PRICE
Railroad boring	LF	50.00	350.00	17,500.00
8" DIP restrained joint	LF	50.00	60.00	3,000.00
8" PVC SDR26 Sewer Main	LF	2,110.00	35.00	73,850.00
Mahnoles	VF	91.00	500.00	45,500.00
8"x4" Wye/Tee with 45 degree elbow and plug	EA	13.00	250.00	3,250.00
8" PVC SCH40 service line	LF	160.00	30.00	4,800.00
testing	JOB	1.00	2,500.00	2,500.00
final grading, cleanup	JOB	1.00	3,500.00	3,500.00
SWPPP	JOB	1.00	5,000.00	5,000.00
				-
				-
				-
				-
				-
				-
				-
				-
CONSTRUCTION TOTAL				\$ 158,900.00

design engineering, construction engineering, observ	12%	\$ 19,068.00
contingencies	10%	\$ 15,890.00
TOTAL		\$ 193,858.00

Crete west 13th Annexation Water

Description	UNIT	Total	Unit Price	TOTAL PRICE
8" PVC DR18 Water Line	LF	3,430.00	30.00	102,900.00
8" DIP CL 52 Water line restrained joint	LF	60.00	60.00	3,600.00
Railroad boring and casing	LF	50.00	350.00	17,500.00
6" PVC DR 18 water line	LF	60.00	30.00	1,800.00
8"x6" tee	EA	7.00	500.00	3,500.00
8" tee	EA	5.00	500.00	2,500.00
8" valve with roadway box	EA	19.00	1,200.00	22,800.00
8" MJ plug	EA	4.00	250.00	1,000.00
8" sleeve	EA	1.00	200.00	200.00
6" Valve with roadway box	EA	6.00	1,000.00	6,000.00
6" Fire Hydrant	EA	5.00	3,500.00	17,500.00
1" service connections, tap and curb stop with box	EA	13.00	700.00	9,100.00
1" SDR 9 service line	LF	470.00	25.00	11,750.00
testing	JOB	1.00	2,500.00	2,500.00
final grading, cleanup, road gravel	JOB	1.00	5,000.00	5,000.00
				-
CONSTRUCTION TOTAL				\$ 207,650.00

design engineering, construction engineering, observ	12%	\$ 24,918.00
contingencies	10%	\$ 20,765.00
TOTAL		\$ 253,333.00

map



 1" = 200'

ANNEXATION
 226,345



April 13, 2021

Ref: 226.000

Tom Ourada, City Administrator
City of Crete
PO Box 86
Crete, NE 68333

Preliminary Cost Estimate for New Lift Station on 22nd Street - Crete, Nebraska

Enclosed is the preliminary cost estimate and plan for the construction of a new lift station at 22nd and Ivy Street. The preliminary costs do not include land acquisition, permanent and temporary construction easements, and related costs.

The cost estimate includes a fixed set standby generator and automatic transfer switch to be located at the proposed lift station site. The Nebraska Department of Environment and Energy (NDEE) has been enforcing the following provision in Title 123 of their regulations:

Lift stations must be provided with emergency provisions to avoid backups into basements or sanitary sewer overflows. One of the following emergency provisions shall be provided at each lift station:

- (a) The lift station shall be connected to two independent electrical substations;
- (b) A permanent engine driven electrical generator is installed;
- (c) A portable electrical generator is kept available within one hour of travel time and two hours of storage capacity exists before a backup or sanitary sewer overflow occurs; or
- (d) A portable pump and adequate hose or piping is kept available within one hour of travel time and two hours of storage capacity exists before a backup or sanitary sewer overflow occurs.

If we have the minimum two hours of storage capacity before a backup occurs we could eliminate the need and cost of the generator, however, we will have to be able to prove the required storage exists.

My cost estimate assumes substantial dewatering will be required, if this is not the case, the cost could be about \$40,000 less. We would want a geotechnical engineer to bore a hole at the lift station site to determine groundwater conditions and soil bearing capacity.

The proposed lift station for 22nd Street to replace the gravity sewer main connected to the bridge will need to be located on the southeast corner of 22nd and Ivy Street. There is simply not enough room in the right-of-way for the lift station and related structures, especially the required size of excavation to construct the lift station. This will also require the purchase of private property by the City.

If you have any questions or require additional information please contact our office.

Respectfully submitted,

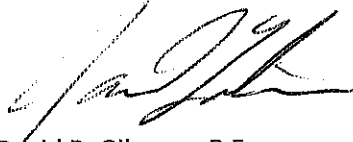
A handwritten signature in black ink, appearing to read 'David B. Gilmore', written in a cursive style.

David B. Gilmore, P.E.
GILMORE & ASSOCIATES, INC.

DBG:va

Enclosures

PRELIMINARY COST ESTIMATE
22nd STREET and IVY
NEW LIFT STATION
(Does not include land acquisition and related costs)

1. Pumping Station, Pumps, and Controls, Valve and Ventilation Manholes, Interior Piping, Fittings, and Valves, Piping and Fittings Between Structures, Electrical Work, Dewatering, and Related Work	\$230,000
2. Standby Generator, Automatic Transfer Switch, and Concrete Pad.	60,000
3. Construct Manholes, 25 V.F.	10,000
4. 6" DIP Force Main, 100 L.F.	3,000
5. 6" IPS, DR9, Directional Bored HDPE Force Main, 400 L.F.	32,000
5. 8" PVC, SDR 26 Sanitary Sewer Main, 125 L.F.	3,800
6. 6" PVC, Service Line, 135 L.F.	2,700
7. Miscellaneous Couplings, Fittings, and HDPE Anchors	7,000
8. Remove and Replace Concrete Paving, 120 Sq. Yds.	9,000
9. Miscellaneous Construction, Testing, etc.	<u>5,000</u>
Total Estimated Construction Cost	\$362,500
Contingencies (10%)	36,300
Engineering Design (Basic Services)	27,300
Geotechnical Engineering	3,000
Construction Phase Engineering, Legal and Administrative, O&M Manual, Interest During Construction, etc.	<u>27,300</u>
TOTAL ESTIMATED PROJECT COST	<u><u>\$456,400</u></u>

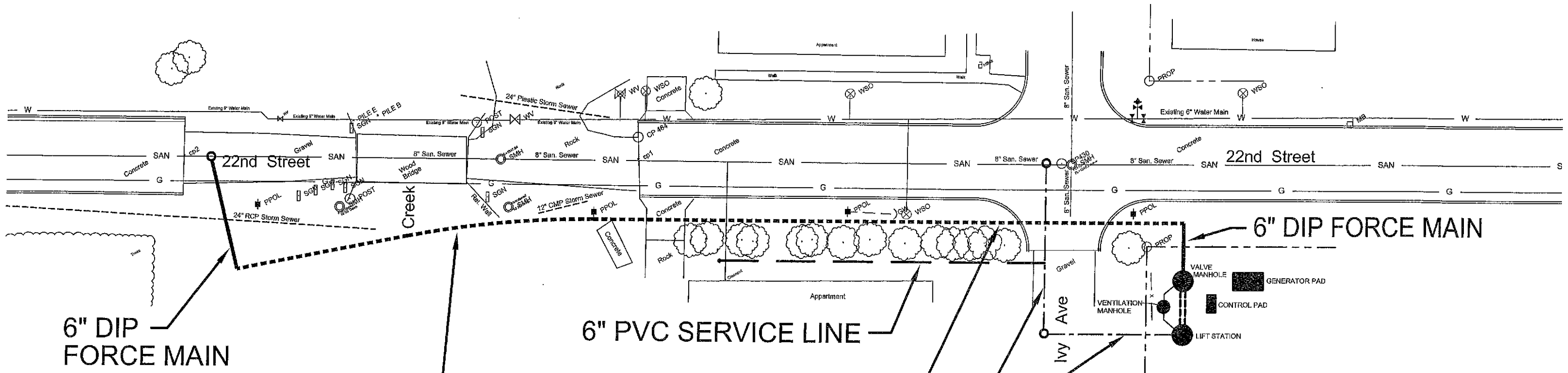

6" DIP FORCE MAIN

6" IPS DR9 HDPE DIRECTIONALLY BORED FORCE MAIN

6" PVC SERVICE LINE

DIRECTIONAL BORE

8" PVC, SDR 26 SEWER MAIN

6" DIP FORCE MAIN

CRETE, NEBRASKA

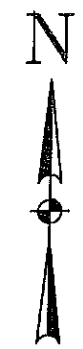
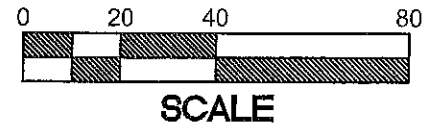

Quote Id: 23791851

Prepared For:
CITY OF CRETE CRETE PUBLIC WORKS



Prepared By: **TAYLOR WENZL**

Murphy Tractor & Equipment
6100 Arbor Road
Lincoln, NE 68517

Tel: 402-467-1300
Mobile Phone: 402-853-4868
Fax: 402-467-1927
Email: twenzl@murphytractor.com

Date: 04 March 2021

Offer Expires: 28 April 2021

Confidential

Quote Summary

Prepared For:
 CITY OF CRETE CRETE PUBLIC WORKS
 241 E 13TH ST
 CRETE, NE 68333

Prepared By:
 TAYLOR WENZL
 Murphy Tractor & Equipment
 6100 Arbor Road
 Lincoln, NE 68517
 Phone: 402-467-1300
 Mobile: 402-853-4868
 twenzl@murphytractor.com

Options:
Add Hydraulic Quick Coupler +\$4792
Add Forks + \$6588

Quote Id: 23791851
Created On: 04 March 2021
Last Modified On: 07 April 2021
Expiration Date: 28 April 2021

Equipment Summary	Qty	Extended
JOHN DEERE 524 P WHEEL LOADER	1	
John Deere Extended Warranty- Extended Warranty (Power Train & Hydraulics) 84m/5000h Travel Time & Mileage NOT Included	1	
Equipment Total		\$ 141,536.17

Quote Summary	
Equipment Total	\$ 141,536.17
SubTotal	\$ 141,536.17
Total	\$ 141,536.17
Balance Due	\$ 141,536.17

NMC
 Cat 926 m \$ 174,590
 cat 926 trade - 3,500
\$ 171,090

Titan Machine
 Case 926 equiv. \$ 154,500
 Cat 926 trade 3,500
\$ 151,000

Salesperson : X _____

Accepted By : X _____

Selling Equipment

Quote Id: 23791851

Customer: CITY OF CRETE CRETE PUBLIC WORKS

JOHN DEERE 524 P WHEEL LOADER

Hours:
Stock Number:

Description	Qty
524 P WHEEL LOADER	1

Standard Options - Per Unit

JDLink Ultimate 5 Year Subscription	1
John Deere PowerTech Engine	1
Standard Wheel Loader	1
5-Speed Powershift Transmission	1
100 amp Alternator	1
Flat Black Curved Stack	1
Standard Engine Air Intake System	1
Standard Hydraulic Fan	1
Standard Fuel Filter with Water Separator and Standard Fuel Fill	1
Standard Cab	1
7 inch Monitor	1
Hydrau Hydraulic Fluid	1
High Lift Z-BAR	1
Steering Wheel Only	1
Deluxe Seat, Cloth with Air Suspension	1
Joystick Controls	1
Three Function Hydraulics	1
Ride Control	1
English Decals and Manuals	1
8 Amp Converter	1
No Payload Scale without Cycle Counter	1
High Traction - Front & Rear	1
Hydraulically Locking Differential Axles	1
Manual Axle Differential Lock	1
Titan TGD2, 20.5R25 L2 Single Star	1
Radial Tires with 3pc Rims	1
Standard Front Fenders	1
Left Side Steps Only	1
No Fork Frame	1
No Tines	1
Halogen Work and Drive Lights	1
Rear Hitch and Counterweight	1
Rear Camera	1

Selling Equipment

Quote Id: 23791851

Customer: CITY OF CRETE CRETE PUBLIC WORKS

LED Strobe Beacon with Left Beacon Bracket	1
Standard Exterior Mirrors	1
Standard Radio	1
Cab with Air A/C Charge	1
Factory Pin-on Bucket Ready	1
Bolt-on Cutting Edge	1
2.75 Cu. Yd. Bucket	1
Wheel Spin Control System	1
Axle Oil Cooling and Filtration	1
Fire Extinguisher	1

Service Agreements

John Deere Extended Warranty -
Extended Warranty (Power Train &
Hydraulics) 84m/5000h Travel Time
& Mileage NOT Included

RESOLUTION NO. 2021-04

A RESOLUTION OF THE CITY OF CRETE, NEBRASKA ESTABLISHING THE MASTER FEE SCHEDULE FOR FISCAL YEAR 2020-2021.

WHEREAS, on April 6, 2021, the City Council enacted Ordinance 2123, which shall take effect on April 21, 2021 and provides for the establishment of a Master Fee Schedule;

WHEREAS, pursuant to Ordinance 2123 and the newly created Crete Municipal Code § 1-930, the City Council shall adopt an annual Master Fee Schedule, which shall establish the rates, fees, charges, and other costs imposed by the City for goods and services provided to the public, for permits, licenses, and other grants of privilege, and for any other costs that may be imposed by law; and

WHEREAS, the City Council has reviewed and compiled the rates, fees, charges, and other costs imposed by the City for goods and services and has determined the attached Master Fee Schedule contains a comprehensive and accurate delineation of appropriate rates, fees, charges, and other costs for fiscal year 2020-21.

NOW, THEREFORE, BE IT RESOLVED BY THE MAYOR AND CITY COUNCIL OF THE CITY OF CRETE, NEBRASKA:

Section 1. That the Master Fee Schedule attached to this resolution and incorporated herein by reference shall be adopted as the City of Crete’s Master Fee Schedule for fiscal year 2020-21.

Section 2. That the attached Master Fee Schedule shall become effective on April 22, 2021.

PASSED AND ADOPTED this 20th day of April 2021.

Mayor

ATTEST:

City Clerk



Master Fee Schedule

Fiscal Year 2020-21

TABLE OF CONTENTS

Part I: General Administration

Administrative Services	1
Businesses and Organizations.....	1
Fire and Rescue Services	1
Library Services	2
Parks and Recreation	2
Police and Code Enforcement.....	3

Part II: Building and Construction

Commercial Building Permits	4
Residential Building Permits	5
Miscellaneous Fees.....	6
Inspections and Plan Review.....	6
Public Property and Right-of-way	7
Signs and Awnings	7
Specialized Trade and Contractor Licensing.....	7

Part III: Land Development, Planning, and Zoning

Land Use and Zoning Compliance	8
Plat Review and Recording.....	8
Special Requests.....	8
Subdivision Development.....	8

Part IV: Public Works and Utilities

Electric Service.....	8
Sewer Service.....	11
Solid Waste Collection	13
Water Service.....	15

PART I: GENERAL ADMINISTRATION

Administrative Services

Recording/Filing Fee	\$10.00 for first page; \$6.00 per page for each additional
Certification Fee	\$1.50 per page
Notice Publication Fee	\$15.00
Copy Fee	\$0.25 per page
Election Filing Fee	1% of annual salary of elected position
Returned Check Charge	\$20.00
Tax Increment Financing	
Application Fee	\$500
Processing Fee	\$1,500
Administrative Fee	1% of TIF Note principal

Businesses and Organizations

Business Registration Fee	\$20.00
Itinerant Merchant/Peddler Permit	
Standard Permit	\$25.00
Seasonal Permit	\$325.00
Snow Removal License	\$10.00
Liquor License Application Fee	\$25.00
Bingo Permit	\$10.00
Junk Dealer License	\$10.00
Tobacco Dealer Application Fee	\$15.00
Tobacco Retail License	\$50.00
Tobacco Wholesale License	\$100.00
Amusement Device License Fee	\$10.00 per device

Fire and Rescue Services

Fire and Rescue Services

Burn Permit Fee	\$10.00
Fire Safety Inspection Fee	\$50.00
Treat and Release	\$175.00
Ambulance Stand-by Service	\$100.00

Ambulance Services

Basic Life Support (BLS)	
Ambulance Service, non-emergency	\$1,030.00 plus mileage rate
Ambulance Service, emergency	\$1,140.00 plus mileage rate
Mileage, per mile patient travels	\$23.00 per mile

Advanced Life Support (ALS)	
Ambulance Service, non-emergency	\$1,250.00 plus mileage rate
Ambulance Service, emergency - Level 1	\$1,410.00 plus mileage rate
Ambulance Service, emergency - Level 2	\$1,760.00 plus mileage rate
Mileage, per mile patient travels	\$23.00 per mile
Advanced Life Support Intercept	\$100.00

Library Services

Non-resident Membership Fee	\$30.00 per year
Late Return Fee – Print and Audiobooks	\$0.00
Late Return Fee – DVDs	\$0.10 per day, up to \$5.00 maximum
Copier/Printer Rates – 8.5" by 11" Black and White	\$0.10 per page
Copier/Printer Rates – 8.5" by 11" Color	\$0.25 per page
Copier/Printer Rates – Large Paper	Additional fee based on paper size

Parks and Recreation

Recreation Programs

Adult Coed Softball	\$425.00
Kickin' It Martial Arts	\$45.00
Micro Soccer	\$25.00
Micro T-Ball	\$25.00
Youth Basketball	\$30.00
Youth Flag Football	\$45.00
Youth T-Ball	\$25.00
Youth Soccer	\$45.00
Youth Volleyball	\$45.00

Pool and Swimming

Pool - Daily Admissions	
3 yrs. old & under	\$0.00
4 to 17 yrs. old	\$4.00

18 to 54 yrs. old	\$6.00
55+ yrs. old	\$4.00
Pool – Season Passes	
Individual	\$75.00
Two Person	\$95.00
Three Person	\$115.00
Four Person	\$135.00
Five Person	\$155.00
Six or More Person	\$175.00
Pool Parties	\$150.00
Swimming Lessons	
Infant/Toddler Lessons	\$30.00
Youth/Adult Lessons	\$45.00
Swim Team	\$50.00

Parks and Fields

Field Rental	
Field Preparation Fee	\$50.00
Field Rental Fee	\$15.00 per hour
Camping Fees	
Campsite Fee – Tuxedo Park	\$10.00 per day
Extended Stay	As negotiated

Police and Code Enforcement

Vehicle and Traffic Enforcement

Vehicle Impoundment Fee	\$25.00
Impound Storage Fee	\$5.00 per day
Vehicle Hobbyist Permit	\$100.00 per vehicle

Animal Regulations

Domestic Dog and Cat License Fee	
Spayed female or neutered male	\$10.00
Unspayed female or unneutered male	\$20.00
Dangerous Dog License Fee	\$50.00
State License Fee	\$1.25
Impoundment Fee – Domestic Animals	\$20.00 for first offense; \$40.00 for subsequent offenses

Impoundment Fee – Livestock	\$75.00 for first offense; \$150.00 for subsequent offenses
Impoundment Fee – Dangerous or Prohibited Animal	\$200.00 for first offense; \$300.00 for subsequent offenses
Boarding and Care of Impounded Animals	Daily boarding rate, as billed
Euthanasia Charge	As billed by veterinarian

Code Enforcement

Seasonal Grass Mowing	
1st Mowing	\$100 per hour
2nd Mowing	\$150 per hour
3rd and Subsequent Mowings	\$200 per hour
Tree and Brush Removal	\$100 per hour
Graffiti Removal	\$100 per hour
Snow Removal	
1st Removal	\$100 per hour
2nd Removal	\$150 per hour
3rd and Subsequent Removal	\$200 per hour
Nuisance Abatement	\$200 per hour plus landfill fees
Nuisance Hearing Application Fee	\$25.00

PART II: BUILDING AND CONSTRUCTION

Commercial Building Permits

Commercial Construction, Remodel, and Repair	
Estimated Cost of Work	Permit Fee
\$1.00 to \$2,000	\$27.00
\$2,001 to \$5,000	\$48.00
\$5,001 to \$100,000	\$48.00 plus \$4.28 per \$1,000 over \$5,000
\$100,000 to \$500,000	\$455 plus \$2.14 per \$1,000 over \$100,000
\$500,000 to \$1,000,000	\$1,311 plus \$1.60 per \$1,000 over \$500,000
\$1,000,000 and over	\$2,113 plus \$1.07 per \$1,000 over \$1,000,000

Commercial Plumbing Permits	
Permit Issuance Fee	\$18.25 plus additional fee listed below:
Estimated Cost of Work	Additional Fee
\$1.00 to \$500	\$21.50
\$501 to \$1,500	\$43.00
\$1,501 to \$5,000	\$150.00
\$5,001 to \$10,000	\$321.00

\$10,001 to \$25,000	\$428.00
\$25,001 to \$50,000	\$535.00
\$50,001 to \$100,000	\$642.00
\$100,001 and over	\$642 plus \$1.07 per \$1,000 over \$100,000

Commercial Mechanical Permits	
Permit Issuance Fee	\$37.50 plus additional fee listed below:
Estimated Cost of Work	Additional Fee
\$1.00 to \$500	\$21.50
\$501 to \$1,500	\$43.00
\$1,501 to \$5,000	\$150.00
\$5,001 to \$10,000	\$321.00
\$10,001 to \$25,000	\$428.00
\$25,001 to \$50,000	\$535.00
\$50,001 to \$100,000	\$642.00
\$100,001 and over	\$642 plus \$1.07 per \$1,000 over \$100,000

Residential Building Permits

Residential Construction, Remodel, and Repair	
Estimated Cost of Work	Permit Fee
\$1.00 to \$500	\$24.00
\$501 to \$2,000	\$24.00 plus \$3.00 per \$100 over \$500
\$2,001 to \$40,000	\$69.00 plus \$11.00 per \$1,000 over \$2,000
\$40,001 to \$100,000	\$487 plus \$9.00 per \$1,000 over \$40,000
\$100,001 to \$500,000	\$1,027 plus \$7.00 per \$1,000 over \$100,000
\$500,001 to \$1,000,000	\$3,827 plus \$5.00 per \$1,000 over \$500,000
\$1,000,001 and over	\$6,327 plus \$3.00 per \$1,000 over \$1,000,000

For the purpose of determining the estimated cost of work for residential projects, the following minimum square footage valuations will be used for new residential construction, additions, remodels, and residential accessory buildings:

Dwelling Unit	\$81.52 per sq. ft.
Finished Basement	\$24.56 per sq. ft.
Unfinished Basement	\$16.40 per sq. ft.
Accessory Building (inc. attached garages)	\$19.14 per sq. ft.
Deck	\$14.41 per sq. ft.
Concrete Slabs & Driveway	\$3.45 per sq. ft.

Residential Plumbing Permits	
New Construction Plumbing Package	\$37.50 per dwelling unit
Permit Issuance Fee	\$18.25 plus the individual costs listed below:
Bathtub	\$6.50
Clothes Washer	\$4.25
Dish Washer	\$3.25
Floor Drain	\$4.25
Garbage Disposal	\$6.50
Laundry Tub	\$6.50
Lavatory	\$6.50
Lawn Irrigation System	\$16.00
Sewer Service Line	\$18.25
Shower	\$6.50
Sink	\$6.50
Water Closet	\$6.50
Water Conditioner	\$8.00
Water Heater	\$8.50
Water Service Line	\$18.25

Residential Mechanical Permits	
New Construction Plumbing Package	\$37.50 per dwelling unit
Permit Issuance Fee	\$18.25 plus the individual costs listed below:
Furnace Replacement	\$21.50
Central Air Replacement	\$21.50

Miscellaneous Fees

Fence Permit	\$16.00 or \$21.50 if easement encroachment
Building Moving Permit	\$75.00
Mobile Home Permit	\$27.00
Demolition Permit	\$30.00
Water Well Permit	\$50.00
On-site Wastewater Permit	\$50.00
Pool and Spa Permit	\$125.00

Inspections and Plan Review

Inspection Fee	\$50.00 per inspection
Plan Review Fee	\$35.00 per hour
Certificate of Occupancy	\$125.00

Public Property and Right-of-way

Barricade Fee	\$50.00 per day
Curb Cut Permit	\$8.50 per linear foot with a \$50.00 minimum
Excavation Permit	\$50.00
Street & Alley Right-of-Way Permit	\$75.00
Sidewalk Right-of-Way Permit	\$35.00
Sidewalk Café Permit	\$50.00 plus \$0.25 per sq. ft. of sidewalk space

Signs and Awnings

Sign Permit Fee	\$27.00 or \$1.00 per sq. ft., whichever is greater
Awning Permit Fee	\$40.00 or \$4.00 per sq. ft., whichever is greater

Specialized Trade and Contractor Licensing

Examination Fees	
Master Plumber Contractor	\$50.00
Journeyman Plumber	\$50.00
Water Conditioning Contractor/Installer	\$50.00
License & Registration Fees	
Master Plumber Contractor	\$75.00
Journeyman Plumber	\$37.50
Plumber's Apprentice	\$25.00
Lawn Irrigation Contractor	\$25.00
Water Conditioning Contractor/Installer	\$75.00
Late Registration Fees	\$20.00 per month
Unregistered Work Penalty	\$200.00 each instance

The permit fee for building, constructing, or engaging in any activity that requires a building permit or other permit issued by the Building Inspector or Public Works Department prior to the application and receipt of such permit shall be four times the regular permit fee plus any additional fines, fees, penalties, or costs that may otherwise be imposed by law.

PART III: LAND DEVELOPMENT, PLANNING, AND ZONING

Land Use and Zoning Compliance

Floodplain Development Permit	\$250.00
Certificate of Zoning Compliance	\$125.00
Zoning Enforcement Fee	\$50.00 per visit
Comprehensive Plan Amendment	\$300.00

Plat Review and Recording

Preliminary Plat	\$1,000 plus \$10.00 per lot
Final Plat	\$600 plus \$10.00 per lot
Other Plats	\$425
Recording Fee	\$20.00 plus \$6.00 per page

Special Requests

Special Exception Permit	\$160.00
Zoning Change	\$500.00
Variance Request	\$135.00

Subdivision Development

Application Fee	\$50.00
Subdivision Review Fee	\$160.00
Inspection Fee	\$50.00 per inspection
Recording Fee	\$20.00 plus \$6.00 per page

PART IV: PUBLIC WORKS AND UTILITIES

Electric Service

Residential Service Rates

Residential Services, all classifications, per month	
Customer charge	\$17.00
Rate per kWh – Summer	\$0.1106 per kWh
Rate per kWh – Winter	\$0.1030 per kWh for first 650 kWh used; \$0.0813 per kWh over first 650 kWh used
Load management credit (Summer only)	\$2.50 per controlled kW or HP

General Service Rates

General Services, all classifications except General Service; Demand, per month	
Customer charge, single phase service	\$31.44
Customer charge, three phase service	\$55.28
Rate per kWh – Summer	\$0.1127 per kWh
Rate per kWh – Winter	\$0.1127 per kWh for first 1,200 kWh used; \$0.0932 per kWh over first 1,200 kWh used
Load management credit (Summer only)	\$2.50 per controlled kW or HP

General Service; Demand, per month	
Customer charge	\$81.30
On-peak demand charge – Summer	\$28.73
On-peak demand charge – Winter	\$20.87
Off-peak demand charge – Summer	\$9.76
Off-peak demand charge – Winter	\$20.87
Rate per kWh – All seasons	\$0.0444 per kWh

Large Power Service Rates

Large Power Service; LP1, per month	
Customer charge	\$205.96
On-peak demand charge – Summer	\$26.02
On-peak demand charge – Winter	\$20.33
Off-peak demand charge – Summer	\$8.13
Off-peak demand charge – Winter	\$0.00
Rate per kWh – All seasons	\$0.0390 per kWh

Large Power Service; LP2, per month	
Customer charge	\$205.96
On-peak demand charge – Summer	\$26.02
On-peak demand charge – Winter	\$18.97
Off-peak demand charge – Summer	\$8.13
Off-peak demand charge – Winter	\$0.00
Rate per kWh – All seasons	\$0.0379 per kWh

Irrigation Service Rates

Customer charge	\$43.36
On-peak HP charge	\$92.14
Off-peak HP charge	\$31.44
Rate per kWh	\$0.0813 per kWh

The rates above are for the Irrigation Season from June 1 through September 30. During the Off-season, the energy charge for all kWh used is based on the General Service G rate. There is a minimum seasonal charge that is the greater of: the HP charge or \$120. The billing HP is the nameplate rating of the motors connected to this service classification.

Lighting Service Rates

City Street Lighting (SL), per month	
Customer charge	\$7.05

Rate per kWh – Summer	\$0.0565 per kWh
Rate per kWh – Winter	\$0.0603 per kWh

Rental Lighting (PL)	
Customer charge	\$7.05
PL1 – 175 watt mercury vapor light	\$8.16 per fixture
PL2 – 100/150 watt sodium vapor light	\$7.37 per fixture
PL3 – 400 watt mercury vapor light	\$14.05 per fixture
PL4 – 400 watt sodium vapor light	\$14.05 per fixture
PL7 – 1,000 watt mercury vapor light	\$21.17 per fixture

Rental Lighting (ML)	
Customer charge	\$7.05
ML1 – 175 watt mercury vapor light	\$4.39 per fixture
ML2 – 100/150 watt sodium vapor light	\$4.16 per fixture
ML3 – 400 watt mercury vapor light	\$5.44 per fixture
ML4 – 400 watt sodium vapor light	\$5.12 per fixture
ML7 – 1,000 watt mercury vapor light	\$6.81 per fixture

Cogeneration Rates

Owners of small power and energy production facilities must enter into a small power and cogeneration agreement with the City.

Cogeneration CG1	
Customer charge – 240 volts or less	
Single phase meter	\$13.00 per meter
Three phase meter	\$29.00 per meter
Customer charge – Over 240 volts	
Single phase meter	\$29.00 per meter
Three phase meter	\$51.00 per meter
Rate per kWh for energy purchased by the City	\$0.0378 per kWh

Cogeneration CG2	
Customer charge – All voltages	
Single phase meter	\$29.00 per meter
Three phase meter	\$51.00 per meter
Rate per kWh for energy purchased by the City	\$0.0378 per kWh

The rate per kWh for energy purchased by the City will have a fuel and energy adjustment applied to the electric rate classification for retail power and energy sales to the producer, based on the pooled energy adjustment assessed by the City's power supplier.

Production Cost Adjustment

The base production cost presently in effect is \$0.07524 per kWh, including purchased power costs and transmission service.

Fees and Charges

Service Deposits	
Residential Services	
R and RL, except mobile homes	\$100.00
R and RL, mobile homes	\$250.00
RH and RHL, single-dwelling units	\$250.00
RH and RHL, multiple-dwelling units	\$150.00
General Services	
All general services	80% of the total amount of two months bills, with a minimum of \$50.00
Large Power Services	As set by contract with the City

The service deposits listed above shall apply to all new applications for electric service. The deposits do not apply to existing accounts or transfers of service within the service area of the City unless the customer’s rate classification changes.

Any service deposit collected according to this schedule from RH and RHL applicants may be reduced by thirty percent (30%) when a customer has maintained on-time payments for twelve consecutive months.

Connection Charges	
Connections or reconnections made during normal working hours	\$35.00
Connections or reconnections made outside normal working hours at the customer’s request	\$50.00
Late Payment Charges	Additional 10%
Collection Charge	\$5.00
Returned Check Charge	\$20.00
Waiver/Due Date Extension Charge	\$2.00 per day

Sewer Service

Sewer Service Rates

All Residential Service Classes	
Customer charge	\$29.70
Rate per 1,000 gallons of water consumption	\$2.63

All Commercial Service Classes	
Customer charge	\$32.40
Rate per 1,000 gallons of water consumption	\$2.63

All Industrial Service Classes	
Customer charge	\$3,000.00
Rate per 1,000 gallons of water consumption	\$1.84

- For Residential Service Classes, the variable rate is based on the average monthly water consumption for the lowest three months of water usage during the months of November, December, January, February, and March.
- For Commercial Service Classes, the variable rate may be based on the average monthly water consumption for the lowest three months of water usage during the months of November, December, January, February, and March or on the actual water consumption each month.
- For Industrial Service Classes, the variable rate is based on the actual water consumption each month.

Along with the general service rates listed in the table above, additional surcharge rates will be assessed to any customers who discharge high strength wastewater:

Surcharge Rates	
Biochemical Oxygen Demand	\$0.44 per pound of B.O.D.
Total Suspended Solids	\$0.22 per pound of T.S.S.
Total Kjeldahl Nitrogen	\$0.81 per pound of T.K.N.

Fees and Charges

Tap Fees and Charges	
4" Sewer Service	\$615.00
Larger than 4" Sewer Service	As negotiated
Charges for removal and replacement of paving, etc.	Actual costs

Service Deposits	
Residential Service Classes	\$10.00
Commercial Service Classes	150% of the average monthly charge
Industrial Service Classes	150% of the average monthly charge

Connection Service Charges	
Connections or reconnections made during normal working hours	\$35.00
Connections or reconnections made outside normal working hours at the customer's request	\$50.00
Late Payment Charges	Additional 10%

Collection Charge	\$5.00
Returned Check Charge	\$20.00
Waiver/Due Date Extension Charge	\$2.00 per day

Slug Treatment

Slug Treatment Fees and Charges	
Service Charge	\$15.00 per visit
Load Charge, whichever is greater:	
Flat rate	\$20.00 per load
Variable rate	\$3.00 per 100 lbs. C.O.D. per load plus \$5.00 per 100 lbs. Dry Solids per load plus \$0.50 per 1,000 gallons of flow per load
Labor Charge	\$20.00 per man-hour
Supplies Charge	\$10.00 per barrel of grit

All slug delivered for treatment is subject to inspection. The City reserves the right to refuse any slug at any time and may require any person delivering slug for treatment to provide test results of the slug composition.

Solid Waste Collection

Residential Rates

Residential Rates, per month	
1 Cart	\$19.95
2 Carts	\$24.70
Yard Waste, optional	\$12.00

Commercial Rates

For the collection of solid waste and recyclable materials placed in approved carts or toters, with occasional overages, from commercial customers, the following rate schedule shall apply:

Commercial Rate Schedule – Carts/Toters		
Pickup Frequency (per week)	\$/month - 1 Cart/Toter	\$/month - 2 Carts/Toters
1 time	\$19.85	\$32.05
2 times	\$33.25	\$44.88
3 times	\$45.53	\$57.44
4 times	\$59.48	\$70.62
5 times	\$72.39	\$84.31
6 times	\$84.89	\$96.83

For the collection of solid waste and recyclable materials placed in approved dumpsters, with occasional overages, from commercial customers, the following rate schedule shall apply:

Commercial Rate Schedule – Dumpsters					
Pickup Frequency (per week)	\$/month per Dumpster Size (yards)				
	2 yards	3 yards	4 yards	6 yards	8 yards
1 time	\$55.56	\$72.71	\$97.02	\$145.54	\$194.06
2 times	\$84.28	\$108.46	\$193.88	\$291.09	\$388.12
3 times	\$112.00	\$145.42	\$291.09	\$436.64	\$581.89
4 times	\$157.33	\$182.37	\$388.12	\$582.19	\$776.25
5 times	\$201.39	\$219.32	\$485.16	\$727.74	\$970.32
6 times	\$241.66	\$256.27	\$582.19	\$873.30	\$1,164.39

Transfer Station Rates

For the deposit of solid waste and recyclable materials at the Transfer Station, the following rate schedules shall apply:

Transfer Station Rate Schedule – Household Trash	
Amount/Type	Rate
Trash bag (13 gal.)	\$1.00 per bag
Trash can/Toter	\$5.00 per can/toter
Car trunk load	\$11.00 per trunk load
Small Pickup load	\$16.00 per pickup load
Large Pickup load	\$27.00 per pickup load
Trailer load	\$44.00 per trailer load
Miscellaneous large items (<i>i.e.</i> sofas, mattresses, etc.)	\$11.00 per miscellaneous large item

Transfer Station Rate Schedule – Construction Materials (Roofing, Shingles, Plaster, Wood)	
Amount/Type	Rate
Trash can/Toter	\$11.00 per can/toter
Small Pickup load	\$44.00 per pickup load
Large Pickup load	\$60.00 per pickup load
Trailer load	\$88.00 per trailer load

Transfer Station Rate Schedule – Recycling Materials	
Amount/Type	Rate
Recyclable Materials*	\$0.20 per pound (minimum of \$1.00)

*Recyclable materials includes: cardboard, aluminum, tin, mixed paper, empty aerosol cans, and plastics numbered 1-7.

Water Service

Service Charge

The monthly service charge for all customer classifications except cash water sales is determined by the size of the meter through which the customer receives service:

Meter Size	Meter Equivalent	Monthly Service Charge
3/4"	1.67	\$17.77
1"	2.67	\$29.05
1 1/2"	3.33	\$58.84
2"	5.33	\$94.05
3"	10.00	\$175.56
4"	16.66	\$293.21

Water Service Rates

The following monthly water service rates are determined by the amount of water passing through the meter:

General Service Rate, per month	
First 50,000 gallons used	\$1.00 per 1,000 gallons
Over the first 50,000 gallons used	\$0.83 per 1,000 gallons
Off-peak Service Rate, per month	
	\$0.60 per 1,000 gallons
Cash Water Sales	
Service charge	\$3.00
Rate per 1,000 gallons	\$4.00

Fees and Charges

Service Deposits	
Permanent meters	\$10.00
Mobile service meters	\$100.00

Tap Fees and Charges	
3/4" water service	\$588.00 plus \$9.50 per foot over 60 feet
1" water service	\$642.00 plus \$11.00 per foot over 60 feet
1 1/2" water service	\$883.00 plus \$15.00 per foot over 60 feet
2" water service	\$1,284.00 plus \$21.50 per foot over 60 feet
Larger than 2" Water Service	As negotiated
Charges for removal and replacement of paving, etc.	Actual costs

Connection Charges	
Lots up to 44' of frontage	\$308.00
Lots over 44' of frontage	\$7.00 per foot of frontage
Connection Service Charges	
Connections or reconnections made during normal working hours	\$35.00
Connections or reconnections made outside normal working hours at the customer's request	\$50.00

Maintenance Service Charge	\$10.00 per month
Late Payment Charges	Additional 10%
Collection Charge	\$5.00
Returned Check Charge	\$20.00
Waiver/Due Date Extension Charge	\$2.00 per day

Customers will not be charged for service calls unless the service issues are due to the customer's actions or facilities or caused by freezing or mechanical damage. In such events, there will be a \$35.00 service call charge plus labor and materials.



Whereas, In 1872, J. Sterling Morton proposed to the Nebraska Board of Agriculture that a special day be set aside for the planting of trees, and

Whereas, this holiday, called Arbor Day, was first observed with the planting of more than a million trees in Nebraska, and

Whereas, Arbor Day is now observed throughout the nation and the world, and

Whereas, trees can reduce the erosion of our precious topsoil by wind and water, cut heating and cooling costs, moderate the temperature, clean the air, produce life-giving oxygen, and provide habitat for wildlife, and

Whereas, trees are a renewable resource giving us paper, wood for our homes, fuel for our fires and countless other wood products, and

Whereas, trees in our city increase property values, enhance the economic vitality of business areas, and beautify our community, and

Whereas, trees, wherever they are planted, are a source of joy and spiritual renewal.

Now, Therefore, I, _____, Mayor of the City of
_____, do hereby proclaim
_____ as

Arbor Day

In the City of _____, and I urge all citizens to celebrate Arbor Day and to support efforts to protect our trees and woodlands, and

Further, I urge all citizens to plant trees to gladden the heart and promote the well-being of this and future generations.

Dated this _____ day of _____
Mayor _____

LEGISLATIVE BULLETIN

LEAGUE OF NEBRASKA MUNICIPALITIES

107th Legislature, First Session

April 9, 2021 - Bulletin 15



ITEMS OF INTEREST TO MUNICIPALITIES

- **LB 51:** As requested in last week's Bulletin, please forward to your **Police Chief** this update with a **WHITE COPY** of the bill (**AM745**) as advanced to **General File**; League Executive Board accepts the League staff recommendation to approve the "proposed negotiated agreement" so the bill would be more workable for police departments across the state
- **LB 83:** Thanks to Sen. Flood for introducing this League-supported bill to amend the Open Meetings Act and successfully encouraging Senators to adopt AM750 before advancing the bill to Final Reading
- **Lawmakers give 1st-round approval to budget package**
- **LBs 24, 44, 159, 163, 368, 369:** Update on bills enacted into law
- **LB 408:** Thanks for informing your **Senator(s) ASAP** about the **unworkable, damaging effects of this bill to limit property tax growth to 3% a year**; please read **Sandra Schendt's letter** and others below providing **SPECIFIC** information about the effects of the bill
- **LB 644:** League opposed bill (as introduced) and **AM755** to **LB 644**, which would require certain political subdivisions within a county requesting more property tax dollars than the prior year to participate in a 'joint public hearing' at the same time on the same day; **the League, NACO (counties), NASB (schools) and NCCA (community colleges) continue working with Senators on amendments to make AM755 as workable as possible**

LB 51: As requested in last week's Bulletin, please forward to your Police Chief this update with a WHITE COPY of the bill (AM745) as advanced to General File; League Executive Board accepts the League staff recommendation to approve the "proposed negotiated agreement" so the bill would be more workable for police departments across the state

As reported last week, on March 16, Sean Kelley (FOP Lobbyist) informed the League that Sen. Steve Lathrop, Chair of the Judiciary Committee (and introducer of LB 51), had just agreed to the "proposed negotiated agreement" that was presented in detail to Police Chiefs and other municipal officials during the League's Zoom Meeting on March 15 at 2 pm CT. The "proposed negotiated agreement" reviewed by the League IN DETAIL on March 15 was embargoed and could not be emailed until March 17.

On March 19, Sen. Lathrop emailed the League a DRAFT "WHITE COPY" of LB 51 which later was revised with technical amendments as well as other provisions that relate to certified law enforcement officers working for the railroads and web site provisions which were included in the email sent to League members March 17.

On March 31, the Judiciary Committee placed LB 51 on General File with Standing Committee Amendment (AM745) with 7 ayes, 0 nays and 1 absent (Sen. Slama).

[Click here](#) for **Standing Committee Amendment (AM745), a "WHITE COPY" of LB 51.**

[Click here](#) for the **Judiciary "Committee Statement"**; please read the "Explanation of Amend-

ment" at the bottom of the Committee Statement.

BACKGROUND:

On March 19, the League Executive Board accepted a League staff recommendation to approve the "proposed negotiated agreement" and support the bill. Clearly, the "proposed negotiated agreement" does not address all of the many concerns expressed to the League by Police Chiefs and other municipal officials from cities of the first class, second class and villages. Notwithstanding, the "negotiated agreement" would make SIGNIFICANT amendments to LB 51 so the bill is more workable for police departments across the state.

As reported in numerous League Legislative Bulletins and emails, LB 51 (as originally introduced) was strongly **OPPOSED** by the **League, Nebraska Sheriffs Association (NSA) and Greater Cities of Nebraska.**

Representatives of the **FOP, PCAN and United Cities of Sarpy County** testified with others in **SUPPORT** of LB 51 (as originally introduced).

Thanks to Sen. Lathrop for accepting the "proposed negotiated agreement" after spending several hours negotiating in good faith with the League and NSA to address some of our most important issues

and concerns about the effects of LB 51, especially on smaller law enforcement agencies. There was never any doubt that Sen. Lathrop had the votes to advance LB 51 (as originally introduced) from the Judiciary Committee; although the requirements in LB 51 apply to law enforcement officers in the Omaha, Lincoln and La Vista Police Departments, it really has no effect on them since they apparently already are meeting the requirements of the bill. Consequently, it was highly unlikely Senators from Omaha, Lincoln and Sarpy County would vote against LB 51 (as originally introduced). With the support of one or two more Senators, Sen. Lathrop likely would have had the support of 25 plus Senators. Until Sen. Lathrop accepted the "proposed negotiated agreement" on March 16, the League had been encouraging municipalities to continue communicating with their respective Senator(s) to express concerns about the bill in the event it would be necessary to oppose the bill and garner support for amendments on the floor to make the bill more workable, especially for smaller law enforcement agencies. **Russ Westerhold, NSA Lobbyist, also recommended to the NSA Board to accept the "proposed negoti-**

Continued on page 3

LB 83: Thanks to Sen. Flood for introducing this League-supported bill to amend the Open Meetings Act and successfully encouraging Senators to adopt AM750 before advancing the bill to Final Reading

On April 6, **LB 83** was considered on Select File. The Legislature adopted “Enrollment & Review” Amendment 23 (ER23); **ER23** strikes the original sections of LB 83 and essentially is a white copy of the bill, incorporating the Standing Committee Amendment (AM127) adopted on General File on March 15 on a 48-0 vote before the bill was advanced to Select File with another 48-0 vote. [Click here](#) for **ER23**.

Following adoption of ER23, Sen. Flood explained **AM750** was drafted to ER23 to provide technical and clarifying amendments as well as address an issue Sen. Clements raised on General File relating to sanitary and improvement districts. Before being advanced to Final Reading, AM750 to ER23 was adopted on Select File with 41 ayes, 0 nays, 5 present and not voting and 3 excused and not voting.

[Click here](#) for **AM750** which amends section 31-727.02 requir-

ing SIDs to provide notice seven days in advance of all meetings to the clerk of either the city or the county, within whichever zoning jurisdiction the SID is located. Due to this notification requirement which has been in this statute for years, some attorneys have questioned the authority of SIDs to hold an “emergency meeting” as authorized by current law in section 84-1411 (5) of the Open Meetings Act. Section 84-1411(5) authorizes “emergency meetings” **WITHOUT reasonable advance publicized notice** to deal with issues that ONLY pertain to the emergency. AM750 amends section 31-727.02 by providing an exception to the notice requirement for these “emergency meetings” authorized in current law in section 84-1411(5) of the Open Meetings Act.

[Click here](#) for the “Final Reading” copy of LB 83, which likely will be scheduled for consideration some-



Sen. Mike Flood

time next week.

BACKGROUND:

As a quick overview, Sen. Flood explained on Select File that LB 83 was amended by the Standing Committee Amendment (AM127) adopted 48-0 on General File. LB 83 as amended by AM127 would require meetings held by “virtual conferencing” to adhere to the same

Continued on page 4

LB 51: League Executive Board accepts recommendation to approve proposed negotiated agreement regarding police departments

Continued from page 2

ated agreement” and support the bill, which the NSA Board did on a split vote.

A **special thanks** to the Police Chiefs and City Managers/Administrators of **Cozad, Gordon and Gothenburg** for working closely with the League to provide inval-

able information, insights and recommendations to improve the bill, especially for smaller departments. Even though the League received important information and perspectives from many other Police Chiefs and municipal officials across the state, the Police Chiefs and City Managers/Administrators

from these three cities met with the League by Zoom on short notice several times and committed countless hours to assist the League in preparing for negotiations with Sen. Lathrop, FOP and PCAN to minimize the effects of LB 51’s new requirements on law enforcement agencies.

LB 83: Thanks to Sen. Flood for introducing this League-supported bill to amend the Open Meetings Act and successfully encouraging Senators to adopt AM750 before advancing the bill to Final Reading

Continued from page 3

provisions as current law mandates for other public meetings. LB 83 as originally introduced (and as amended) would accomplish two primary objectives.

FIRST, LB 83 would modernize the provisions in section 84-1411 (2) in which “regional” entities hold meetings by “virtual conferencing.” The bill defines **“virtual conferencing” as “conducting or participating in a meeting electronically or telephonically with interaction among the participants.”** The same **“regional”** entities currently allowed to conduct meetings by videoconferencing and/or telephone conference calls would be allowed to hold meetings by “virtual con-

ferencing.” These “regional” entities include solid waste management agencies, ESUs, risk management pools, a number of state entities and others. Like other “regional” entities, LB 83 also would allow the following four “regional” entities to hold no more than half their meetings by “virtual conferencing”: local public health departments, NRDS, MUD and a regional metropolitan transit authority. (See page 11 of LB 83.)

SECONDLY, LB 83 would create the statutory framework for all public bodies (including “nonregional” public bodies like city councils and school boards) to hold meetings by “virtual conferencing” during a declared emergency by the Governor

pursuant to the Nebraska Emergency Management Act. At these virtual meetings, **in addition to any formal action taken pertaining to the emergency**, the public body would be authorized to hold such meeting for the purpose of briefing, discussion of public business, formation of tentative policy, or the taking of any action by the public body. (See page 17 of LB 83.)

(In contrast, provisions in current law in section 84-1411 (5) allowing emergency meetings WITHOUT reasonable advance publicized notice also may be held by “virtual conferencing” but any formal action taken in such meeting shall pertain ONLY to the emergency.)

How a bill becomes a law

1. Bill introduced by Senator
2. Clerk assigns number to bill
3. Bill referred to committee
4. Committee has public hearing
5. Committee votes to:
 - Hold
 - Kill
 - Advance to General File
6. General File
7. Select File
8. Final Reading
9. Bill sent to Governor
 - Bill becomes law without governor's signature
 - Signed by governor
 - Vetoed by governor
10. Veto Override
11. Bill becomes state law

LBs 25, 44, 159, 163, 368, 369: Update on bills enacted into law

The following bills have been passed by the Legislature and signed by the Governor. In other words, these bills have been enacted and will go into effect 90 days after the Legislature adjourns, except for LB 25, which is in effect now because it contained the emergency clause.

LB 25, introduced by **Sen. Justin Wayne** of Omaha, implements the provisions of Amendment 2. LB 25 extends the maximum length of time for the repayment of indebtedness related to tax-increment financing (TIF) in certain cases. Under the bill, if more than one-half of the property in the project area is designated as extremely blighted, the maximum repayment period is extended from 15 years to 20 years.

Lawmakers give 1st-round approval to budget package

Senators April 8 gave 42-0 first-round approval to a \$9.7 billion budget package that allows for a 1.6 percent state spending growth average for the two-year period.

The state budget is structured on a two-year basis with the budget enacted during legislative sessions held in odd-numbered years.

Debate continued April 9 on a contentious plan to build a new prison that Gov. Pete Ricketts supports.

LB 44, introduced by **Sen. Matt Hansen** of Lincoln, clarifies that an affordable housing action plan required under the Municipal Density and Missing Middle Housing Act can be adopted either as part of a city's comprehensive plan or as a separate plan.

LB 159, introduced by the **Urban Affairs Committee**, provides for printing or publishing city and village ordinances in electronic form.

LB 163, introduced by the **Urban Affairs Committee**, is a clean-up bill for Chapter 18 governing all classes of municipalities. The bill clarifies provisions related to municipal initiatives and referenda; clarifies references to municipalities' corporate limits or extraterritorial zoning jurisdiction (ETJ); corrects references to city, village or metropolitan utilities district (MUD) officials; and eliminates run-on sentences.

LB 368, introduced by **Sen. Rita Sanders** of Bellevue, grants discre-

2021
LEGISLATIVE
SESSION



tionary authority to the Auditor of Public Accounts to assess a late fee of \$25 per calendar day when political subdivisions, including municipalities, fail to timely file a required report with the Auditor's office.

LB 369, also introduced by **Sen. Sanders**, mandates unrestricted access by the Auditor of Public Accounts to all working papers and audit files relating to the preparation of any report that must be filed with the Auditor. This bill grants discretion to the Auditor to assess a fee of up to \$25 per day for failure to timely comply with a relevant request.

Legislative hot line offered during session

During the legislative session, the Clerk of the Legislature's Office offers a hot line from 8 a.m. to 5 p.m.

Hot line staff will answer questions about the status of bills or requests for information. This service also is available to any person who is hearing impaired and/or speech

impaired. Before 8 a.m., or after 5 p.m. during the week and on weekends and state holidays, callers will hear a recorded message of the next legislative day's agenda. Legislative hot line numbers are: Lincoln - 402-471-2709; Other areas in Nebraska - 800-742-7456.

LB 644: League opposed bill (as introduced) and AM755 to LB 644, which would require certain political subdivisions within a county requesting more property tax dollars than the prior year to participate in a ‘joint public hearing’ at the same time on the same day; the League, NACO (counties), NASB (schools) and NCCA (community colleges) continue working with Senators on amendments to make AM755 as workable as possible

Blair Sen. Ben Hansen introduced LB 644 to adopt the **Property Tax Request Act** which would, in part, require certain political subdivisions within a county requesting more property tax dollars than the prior year to participate in a ‘joint public hearing’ at the same time on the same day.

On March 11, LB 644 was selected as Sen. Ben Hansen’s **Personal Priority Bill**; the **Revenue Committee advanced LB 644 to General File on March 25 with Standing Committee Amendment (AM755)**. [Click here](#) for AM755.

On April 6, LB 644 was considered on General File. Hastings Sen. Steve Halloran successfully amended AM854 into AM755 (Revenue’s Standing Committee Amendment). [Click here](#) for AM854. AM854 essentially is LB 189, introduced by Sen. Halloran to require property tax refunds owed by a political subdivision to be included in their next budget; such refunds would be required to be paid in full with an interest rate of 9 percent.

Following adoption of AM854 to AM755, Sen. Ben Hansen stated that his rationale for introducing LB 644 was to provide taxpayers more transparency. Elkhorn Sen. Lou Ann Linehan, Chair of the Revenue Committee, also advocated for

adoption of AM755 and the need for greater transparency on how property tax dollars are spent.

Thanks to Gothenburg Sen. Matt Williams, Bellevue Sen. Carol Blood and Omaha Sen. Megan Hunt for their comments defending the hard work of local elected officials.

Even though AM755 now only applies to a county, city, school district or community college, the League strongly opposes AM755 because it is unworkable. AM755 was adopted with 36 ayes, 1 nay and 9 present and not voting. Due to strong support for LB 644 as amended by AM755, the League, NACO (counties), NASB (schools) and NCCA (community colleges) continue working with Senators on amendments to make AM755 as workable as possible.

BACKGROUND:

A League representative testified with the following organizations in OPPOSITION to the bill (as originally introduced) at the Revenue Committee Hearing on Feb. 10: **Nebraska Association of County Officials (NACO)**, **Nebraska Association of School Boards (NASB)**, **Nebraska Rural Community Schools Association (NRCSA)**, **Nebraska Council of School Administrators (NCSA)**

and **Greater Nebraska Schools Association (GNSA)**; “testimony letters” in opposition to LB 644 were submitted by the **Nebraska Community College Association**, **Lancaster County Board of Commissioners** and the **Eastern Nebraska Development Council**. A representative of OpenSky Policy Institute testified in a NEUTRAL capacity.

Representatives of Americans for Prosperity-Nebraska and the Platte Institute testified in SUPPORT of the bill; “testimony letters” in support of the bill were submitted by the Nebraska Bankers Association, National Federation of Independent Business and the Nebraska Chamber of Commerce.

LB 644 (as originally introduced) creates the Property Tax Request Act. AM755 changes the political subdivisions that are affected by this bill to be: a county, city, school district, or community college; villages would not be required to participate in the joint hearing.

If the political subdivision includes area in more than one county, the county in which the principal headquarters are located will the location of the joint public hearing.

The information required to be published on the **postcard that is**

Continued on page 7

LB 408: Thanks for informing your Senator(s) ASAP about the unworkable, damaging effects of this bill to limit property tax growth to 3% a year; please read *Sandra Schendt's letter* and others below providing SPECIFIC information about the effects of the bill

The most effective way to ask your Senator(s) to oppose LB 408 is to email SPECIFIC INFORMATION about how LB 408 would have damaging and long-lasting effects on the ability of your municipality to grow and provide needed services (see examples below). Please also call or meet with your Senator(s) to discuss LB 408 and its negative effects on your city or village. Please let your Senator(s) know the "lid on restricted funds" and "levy limits" also would remain in effect if LB 408 (AM371) is enacted.

League Legislative Bulletins #11 - #14 included **great examples** of the effects of LB 408 (AM371) on

municipal budgets. This *Bulletin* includes the examples from *Bulletins #11 - #14 (charts, letters, etc.)* as well as a great letter to Glenvil Sen. Dave Murman from **Sandra Schendt**, Clerk/Treasurer of Nelson. Please consider these outstanding examples as you develop specific information about LB 408's impact on your municipality's respective budget, economic and community development efforts, and ability to thrive while continuing to provide needed services.

Thanks to the following municipalities which provided the League **excellent information regarding the effects of LB 408 on their city/village** (click on the name of

2021 _____
LEGISLATIVE
SESSION



the municipality): [Ansley](#), [Atkinson](#), [Hastings](#), [Imperial](#), [La Vista](#), [Nelson](#), [Norfolk](#), [Pawnee City](#), [Plattsmouth](#), [Stromsburg](#), [Sutton](#), [Wahoo](#), [West Point](#). [Click here](#) for La Vista's graphic template.

Thanks to municipal officials for copying the League on emails sent to Senators in opposition to LB 408; thank you for also forwarding the response from your Senator(s). The League continues working with a coalition of other statewide organizations to oppose the bill. Emails with specific examples relating to your city or village are invaluable in advocating against passage of the bill.

BACKGROUND:

LB 408, as originally introduced by Albion **Sen. Tom Briese**, limits the annual increase in property taxes, excluding voter-approved bonds and real growth value, for all political subdivisions to 3 percent. As reported in *League Legislative Bulletins #10 and #11*, the Revenue Committee approved AM371 to **LB 408** before advancing the bill to General File on March 2; **AM371**

Continued on page 8

LB 644: League opposed bill (as introduced) and AM755 to LB 644

Continued from page 6

mailed to all affected property taxpayers found in Section 4 will now require the date, time and location for the joint public hearing, a listing of each political subdivision that will be participating in the joint public hearing, a telephone number for each political subdivision and the amount of each participating political subdivision's property tax request.

Additional information on the postcard will be the name of the county that will be holding the joint

public hearing, the parcel number and the name and address of the property owner, the prior year and the current year assessed valuation, the amount of property taxes due in the prior year and the amount of property taxes due for the current year and the change in the amount of property taxes due.

The due date for filing the budget with the Auditor of Public Accounts for all political subdivisions is moved to Sept. 27. The operative date remains as Jan. 1, 2022.

LB 408: Thanks for informing your Senator(s) ASAP about the unworkable, damaging effects of this bill to limit property tax growth to 3% a year; please read *Sandra Schendt's letter* and others below providing SPECIFIC information about the effects of the bill

Continued from page 7

strikes the original provisions of LB 408 and essentially becomes the bill. **On March 9, Lincoln Sen. Suzanne Geist selected LB 408 (AM371) as her personal priority bill.**

AM371 still retains most of the original provisions of the bill to limit the annual increase in property taxes for all political subdivisions to 3 percent, with EXCEPTIONS for: 1) only bonds approved by voters; 2) "real growth value" as defined in the bill; and 3) votes approved by a majority of registered voters in a primary, general or special election to override the 3 percent limit. **Real growth value** is defined in the bill as "the increase in real property valuation due to (a) improvements to real property as a result of new construction and additions to existing buildings, (b) any other improvements to real property which increase the value of such property, and (c) annexation of

property by the political subdivision."

[Click here](#) for AM371 to review several other key provisions in the amendment, which becomes the bill if it is adopted on General File. [Click here](#) for the Statement of Intent of LB 408 as originally introduced. [Click here](#) for the Fiscal Note.

Those testifying in SUPPORT of the bill at the hearing on Jan. 27 included the Lincoln Independent Business Association, the National Federation of Independent Business, and the Platte Institute. All the PROPONENTS expressed concern about the increase of property taxes and spending by political subdivisions.

The OPPONENTS to LB 408, in addition to the **League**, included Lancaster County, community colleges, Banner County, Nebraska Association of School Boards, Omaha Public Schools, Open Sky, Greater Nebraska Schools Associa-

2021
LEGISLATIVE
SESSION



tion, Greater Nebraska Cities, and the Nebraska Association of County Officials. Letters of opposition were submitted by the Holland Center, Gilmore and Bell law firm, Lincoln Public Schools, Millard Public Schools, and others. The representatives of the entities who testified at the hearing expressed concern about the loss of local control, the impact it may have on bonding, and that inflation is often above 3 percent which could be devastating for some political subdivisions. The opponents also raised the issue that political subdivisions are already under levy limits and a lid on restricted funds.