



Oakdale Public School Board of Education Special Meeting  
Tuesday, July 20, 2021  
6:00 PM

Fine Arts Building - Auditorium, 10901 N. Sooner, 5701 E Hefner, Edmond, Oklahoma 73013

1. **Routine Items:**
  - Call to Order
  - Roll Call
  - Establishment of a Quorum
  - Possible consideration and vote to approve Agenda
2. **Pledge of Allegiance, Moment of Silence, & Inspirational Thought**
3. **Public Comment:** All meetings of the Board of Directors shall be open to the public and any regular meeting shall include an opportunity for the public to address the Board. Public Comments are limited to three (3) minutes and must be related to an agenda item or topic. Members of the public wishing to address the board must sign up before the meeting. Where several people wish to address the same subject, a spokesperson must be selected. The Board President may interrupt and terminate any comments that are not in accordance with any of these criteria or in keeping with Board Policy BED . Board members may not respond to speakers' comments. See attachment.
4. **Staff Reports, Presentations, and/or Recognitions**
  - Superintendent's Update: Dr. Joe Pierce
  - Elementary School Principal: Jenna Foster
  - Middle School Principal: Jill Willhoite
  - Independent Committee &/or Sanctioned Organization Reports
5. **Consent Agenda:** The following items concern reports and items of a routine nature normally approved at Board meetings. They will be considered and voted on together as a group with one vote; provided that any Board member may ask that one or more items be considered and voted on separately. The Consent Agenda includes discussion, consideration, and possible action upon the following items:
  - 5.1. Approve minutes of the June 8, 2021 regular board meeting.
  - 5.2. Accept Treasurer's Report including: Financial statements, fund balances, expenditures, revenue, warrants, bank summary, bond reports, and investments) for the month ending June 30, 2021.
  - 5.3. Warrants and encumbrances for both fiscal years 2020-21 and 2021-2022.
  - 5.4. Blanket purchase orders for the 2021-2022 school year based on the 2020-21 financial report.
  - 5.5. General Fund 2020-21 Payments #3014-3030
  - 5.6. General Fund 2021-22 Payments #23-69
  - 5.7. Child Nutrition Payments are included with General Fund Payments
  - 5.8. Building Fund 2020-21 Payments #513-529
  - 5.9. Building Fund 2021-22 Payments #16-28
  - 5.10. Activity Fund 2020-21 Payments #274-284
  - 5.11. No Bond 34 payments for 2020-2021
  - 5.12. No Bond 34 Fund Payments for 2021-2022
  - 5.13. Bond Fund #35 transportation bond, no payments.
  - 5.14. Bond Fund #36 Payments for 2020-2021 #1-2
  - 5.15. Renewal of copier lease agreement with Superior Office Systems.
6. **Information:** Jeff Wegener, architect with LWPB, presentation/updates related to new bond projects (projected timeframe, next steps, plans, and other updates on play equipment selection.)
7. **Business (Action) Items:** The following items will be considered, discussed, and possible action taken on each one separately.

- 7.1. Discussion, consideration, and possible action to approve the pre-final Construction Documents for the Oakdale 2021 Infrastructure Projects and authorize LWPB and CMSWillowbrook to complete the documents and issue for bidding.
- 7.2. Discussion, consideration, and possible action to approve an agreement with LWPB Architecture for the 2021 Master Plan services.
- 7.3. Discussion, consideration, and possible action to approve an agreement with Zonda Education for the 2021 Demographic Study.
- 7.4. Consideration, discussion, and possible action upon financial roles for 2021-2022:
  - Treasurer, Steve Huff
  - Board Clerk, Marlene Dunn
  - Deputy Board Clerk, Becky Lidia
  - Encumbrance Clerk, Marlene Dunn
  - Activity Fund Custodian, Marlene Dunn
  - Activity Fund Co-Custodian, Becky Lidia
  - Federal Programs Manager, Steve Huff
- 7.5. Consideration, discussion, and possible action on directing the district treasurer to conduct financial procedures for the district including the investment and distribution of earnings from those investments, purchase of non-payable warrants in one district fund with money from other available district funds and/or to negotiate the purchase of non-payable warrants from other sources, and all the general duties of the treasurer as outlined in law and policy.
- 7.6. Consideration, discussion and possible action on revisions to Section E of the Board of Education Policy Book as prepared by OSSBA legal services.  
Revised policies in Section E include the following:
  - EBA School Hours
  - EFA School Library Media Center
  - EFA-R1 School Library Media Center Selection of Materials (Regulation)
  - EHA Basic instructional Program
  - EHBDBA Parent Participation in the School District
  - EHBC Special Education
  - EHBC-R4 Special Education Services for Children Enrolled in Private School
  - EHBE Limited English Proficiency Instruction
  - EHBG Early Childhood Education Program
  - EHBH Alternative Education
  - EIA Promotion and Retention
  - EIA-R4 Student Retention (Regulation)
  - EIA-R5 Midyear Promotion Fourth Grade
  - EJ School Counselor
  - EK-R1 Testing Program Student Surveys (Regulation)
  - EMG Animals in School
- 7.7. Consideration, discussion, and possible action on certified & support personnel recommendations as listed in Exhibit A: Personnel Report.
8. **New Business:** Any matter not known about or which could not have been reasonably foreseen prior to the time of posting.

9. **Adjourn:** Possible consideration, discussion, and vote to adjourn.



## **BOARD OF EDUCATION MEETING PUBLIC PARTICIPATION**

The purpose of a Board meeting is for the Board to conduct the District's business and to deliberate and act upon matters before the Board unless the Board is specifically conducting a public forum. The public is encouraged to attend and to observe meetings of the Board and to participate whenever a public forum is being held for the purpose of receiving public input.

During portions of the Board's regular business meetings an opportunity shall be provided for members of the public to make comments regarding school related matters that appear as an action item on the posted agenda. To make such comments, members of the public are to complete the required form and submit it to the Clerk of the Board no less than 15 minutes before the meeting is called to order. Individuals or groups wishing to speak during the public comment period must provide the following information, in writing on the form provided, in order to speak before the board:

- Name of the individual;
- The agenda action item(s) the individual wishes to address;
- The organization the individual represents or is affiliated with, if applicable.

Persons addressing the Board during the "Public Comments" portion of a regular meeting Board meeting shall be allowed three (3) minutes to address the Board. If a group has requested to address the Board on a particular subject, the group will select one representative speaker for the group and will be allowed ten (10) minutes to speak collectively on behalf of the group's members. Groups consisting of three (3) or more persons shall designate a spokesperson who shall speak for and represent the group. Generally, a maximum of fifteen (15) minutes will be allowed for the public comment period. If an extremely large number of requests to speak are received, the Board President may extend the total time limit for comments.

The District provides various grievance and complaint procedures for addressing concerns and complaints. Therefore, to avoid circumvention of those procedures and ensure fairness to all parties, no person will be allowed to place an item on the agenda or speak on the following matters:

1. Any issue involved in pending litigation or any investigation filed with an outside agency wherein the District, any employee, or the Board is a party;
2. Any pending grievances or complaints involving employees or students;
3. An employee disciplinary action, including suspension, demotion, non-reemployment or termination;
4. Any student suspension or appeal of a student suspension.

Persons addressing the Board shall not be permitted to engage in defamatory conduct or criticize individuals and shall not engage in disruptive behavior.

Board members and the District's administrative staff shall not respond to questions or comments from the public since doing so could be in violation of the Oklahoma Open Meeting Act. The Board will not take any action on an item addressed by the public unless such item is properly on the agenda as an action item or is properly considered new business as defined by law.

**CROSS REFERENCE: Policy GF**

**REFERENCE: 70 O.S. §5-118**



## Guidance: House Bill 1775

This spring, the legislature passed and Gov. Stitt signed [House Bill 1775](#), and the state Board of Education subsequently passed an [emergency rule](#) related to the legislation. We've received many questions about HB 1775, and this guidance is intended to provide clarity to school districts. Additional questions can be directed to any member of the OSSBA legal team.

### What does HB 1775 do?

**(UPDATED)** For public schools, the legislation and related emergency rule lists the following concepts that may not be taught to students, included in curriculum or instructional materials, included in employee professional development, or included in diversity, equity or inclusion plans:

- one race or sex is inherently superior to another race or sex,
- an individual, by virtue of his or her race or sex, is inherently racist, sexist or oppressive, whether consciously or unconsciously,
- an individual should be discriminated against or receive adverse treatment solely or partly because of his or her race or sex,
- members of one race or sex cannot and should not attempt to treat others without respect to race or sex,
- an individual's moral character is necessarily determined by his or her race or sex,
- an individual, by virtue of his or her race or sex, bears responsibility for actions committed in the past by other members of the same race or sex,
- any individual should feel discomfort, guilt, anguish or any other form of psychological distress on account of his or her race or sex, or
- meritocracy or traits such as a hard work ethic are racist or sexist or were created by members of a particular race to oppress members of another race.

### Are the prohibited concepts typically taught in public schools?

No. Oklahoma's teachers, particularly history teachers, are skilled at leading and facilitating important conversations on difficult topics, including race and gender.

### Does HB 1775 prohibit teaching or classroom conversations about diversity, race and gender?

No. The rhetoric around HB 1775 during the legislative session and even after has created uncertainty about the practical implications of the bill. The bill clearly states that concepts aligning with state academic standards can continue to be taught, and Gov. Stitt issued an [executive order](#) emphasizing this

aspect of the law. But teachers **are not limited** to teaching or discussing only those concepts/topics specifically mentioned in academic standards.

**(NEW) What policy must our district pass to be compliant with the HB 1775 legislation and related rule?**

OSSBA has a sample policy available to help districts comply with the provisions in law and the rule. It outlines the specific concepts that are prohibited as well as the required complaint process. The policy and district procedures must be incorporated into employee and student handbooks. The name, telephone number, and email address of the person who is designated in policy to receive complaints must also be published on the district website.

**(NEW) What else should district leaders know about the rule related to HB 1775?**

The rule outlines the process by which a complaint can be filed, investigated and reported to state education officials, which is included in the OSSBA sample policy. In lieu of a district complaint, complaints also can be filed with the state Education Department.

The rule also contains the following additional specific prohibitions not referenced in the law:

- Public schools in this state shall be prohibited from providing, contracting to provide, offering or sponsoring any Course(s), that includes, incorporates, or is based on the prohibited concepts.
- Public schools in this state shall be prohibited from using any monies, property, or any other assets or resources to engage in race or sex-based discrimination, including the prohibited concepts.
- Public schools in this state shall be prohibited from adopting programs or utilizing textbooks, instructional materials, curriculum, classroom assignments, orientation, interventions, or counseling that include, incorporate or are based on the prohibited concepts.
- Public schools in this state shall be prohibited from executing contracts or agreements with internal or external entities, persons, companies or businesses to provide services, training, professional development, or any other assistance that includes, incorporates or is based on the prohibited concepts.
- Public schools in this state shall be prohibited from receiving or applying to receive any monies that require, as a condition of receipt, the adoption of a Course(s), policies, curriculum, or any other instructional material that includes, incorporates or is based on the prohibited concepts.
- Public schools in this state shall be prohibited from adopting diversity, equity, or inclusion plans that incorporate the prohibited concepts.
- Diversity officers in public schools shall be prohibited from providing any service or performing duties that include, incorporate, or are based on the prohibited concepts.
- Public schools shall be prohibited from mandating diversity training that includes, incorporates or is based on the prohibited concepts. This includes providing such training to employees, contractors, staff members, parents, students, or any other individual or group.

- Public schools in this state shall be prohibited from adopting policies, including grading or admissions policies, or providing any other benefit or service that applies to students or any school employee differently on the basis of race or sex, unless specifically permitted by Title IX. This prohibition includes segregated classes, programs, training sessions, extracurricular activities, or affinity groups unless otherwise permitted by Title IX.

In addition, the rule outlines potential certification action against employees found in violation of the provisions of the law or rule as well as retaliation and whistle blower protections.

### **What should our district's teachers know about HB 1775?**

You are welcome to share this guidance document with administrators and teachers. Please reassure them that conversations about race, gender and diversity aren't off limits. Rather, the safe place of the classroom is the right and appropriate place for these conversations.

### **(NEW) What should our community about our district's implementation about HB 1775?**

Personal, one-on-one communication will likely be best.

When your district receives questions about HB 1775 or the topics it covers, share the board policy with the community member or parent and explain that the district follows the state's academic standards and does not teach the information prohibited by state law and the board policy. Explain that the district is committed to providing a caring and welcoming environment where the needs of all students are met, including their need to be and to feel respected, safe and heard.

Once the district approves the board policy, post it on the policy portion of the district's website to ensure parents can review it at any time.

Please know the OSSBA communications team is available to assist if you need more in-depth guidance or resources related to HB 1775 communication.

### **Questions?**

OSSBA's advocacy, legal and communications teams are available to answer questions and provide assistance.

**PROHIBITION OF RACE AND SEX DISCRIMINATION IN CURRICULUM AND COMPLAINT PROCESS**

The board of education hereby directs that neither the district, nor any employee of the district shall teach or include in a course for students or employees the following discriminatory principles:

- (1) One race or sex is inherently superior to another race or sex,
- (2) An individual, by virtue of his or her race or sex, is inherently racist, sexist or oppressive, whether consciously or unconsciously,
- (3) An individual should be discriminated against or receive adverse treatment solely or partly because of his or her race or sex,
- (4) Members of one race or sex cannot and should not attempt to treat others without respect to race or sex,
- (5) An individual’s moral character is necessarily determined by his or her race or sex,
- (6) An individual, by virtue of his or her race or sex, bears responsibility for actions committed in the past by other members of the same race or sex,
- (7) Any individual should feel discomfort, guilt, anguish or any other form of psychological distress on account of his or her race or sex, or
- (8) Meritocracy or traits such as a hard work ethic are racist or sexist or were created by members of a particular race to oppress members of another race.

A “course” shall include any forum where instruction or activities tied to the instruction are provided, including training, seminars, professional development, lectures, sessions, coaching, tutoring, or any other class.

Any individual may file a complaint alleging that a violation has occurred of enumerated items 1-8 above. In order for a complaint to be accepted for investigation, it must:

- (A) Be submitted in writing, signed and dated by the complainant, including complaints submitted through electronic mail that include electronic signatures;
- (B) Identify the dates the alleged discriminatory act occurred;
- (C) Explain the alleged violation and/or discriminatory conduct and how enumerated items 1-8 above have been violated;
- (D) Include relevant information that would enable a public school to investigate the alleged violation; and
- (E) Identify witnesses the school may interview. The school will not dismiss a complaint for failure to identify witnesses.

The district hereby designates \_\_\_\_\_ as the employee responsible for receiving complaints. Complaints may be provided via telephone at \_\_\_\_\_ and via email to \_\_\_\_\_. This contact information shall also be accessible on the school district’s website.

Upon receipt of a complaint, the complainant shall receive notification from the designated employee that the complaint has been received and whether it will be investigated within ten (10) days of receipt.

The school district shall investigate all legally sufficient complaints and decide as to whether a violation occurred. The school district shall receive, process and investigate complaints in the same manner as all other complaints of discrimination. The investigation process shall be completed within ninety (90) days of receipt of a claim. Within thirty (30) days of resolution of the complaint, the designated employee shall report the resolution to the State Department of Education.

**PROHIBITION OF RACE AND SEX DISCRIMINATION, Con't**

No individual shall be retaliated against for (1) filing a complaint; or (2) the purpose of interfering with any right or privilege secured by federal civil rights laws and regulations. Any school employee who retaliates against a complainant may be subject to disciplinary action by the school district or by the State Board of Education.

Any teacher who files a complaint or otherwise discloses information that the teacher reasonably believes is a violation of the prohibited concepts listed above shall be entitled to Whistleblower Protections.

Any teacher or other school employee who, willfully, knowingly, and without probable cause makes a false report may be subject to disciplinary action by the school district or by the State Board of Education.

**LEGAL REFERENCE:**        **70 O.S. § 24-157**  
                                      **State Accreditation Standard 210:10-1-23**

**A policy on this issue is required by the  
Standards of Accreditation for Oklahoma Schools  
Effective July of 2021**

***(Please note adoption/use of this sample form is optional and not required by rule or law)***

**PROHIBITION OF RACE AND SEX DISCRIMINATION IN  
CURRICULUM AND COMPLAINT PROCESS  
COMPLAINT FORM**

TO: \_\_\_\_\_,  
This must be submitted in writing either in person or via email.

On the \_\_\_\_ day of \_\_\_\_\_, 20\_\_\_\_, \_\_\_\_\_ (Name of Employee) violated 70 O.S. § 24-157(B) by requiring or making a part of a course taught by the school district the following discriminatory principle:

- (1) One race or sex is inherently superior to another race or sex,
- (2) An individual, by virtue of his or her race or sex, is inherently racist, sexist or oppressive, whether consciously or unconsciously,
- (3) An individual should be discriminated against or receive adverse treatment solely or partly because of his or her race or sex,
- (4) Members of one race or sex cannot and should not attempt to treat others without respect to race or sex,
- (5) An individual’s moral character is necessarily determined by his or her race or sex,
- (6) An individual, by virtue of his or her race or sex, bears responsibility for actions committed in the past by other members of the same race or sex,
- (7) Any individual should feel discomfort, guilt, anguish or any other form of psychological distress on account of his or her race or sex, or
- (8) Meritocracy or traits such as a hard work ethic are racist or sexist or were created by members of a particular race to oppress members of another race.

Please circle the item above that was violated. An explanation of the alleged violation, how the above item was violated, and relevant information to enable the district to investigate the alleged discriminatory conduct includes, but is not limited to:

---

---

---

---

---

---

---

---

---

---

**PROHIBITION OF RACE AND SEX DISCRIMINATION, Con't**

The district may interview the following individuals:

---

---

---

---

---

---

---

---

I, \_\_\_\_\_, attest that the information that I have provided above is correct and accurate.

\_\_\_\_\_  
Complainant

**NOTE: This form is optional; the district is free to require a different document in its place.**

## 210: 10-1-23 [NEW] Prohibition of Race and Sex Discrimination

- (a) **Purpose.** It shall be the policy of the Oklahoma State Board of Education to prohibit discrimination on the basis of race or sex in the form of bias, stereotyping, scapegoating, classification, or the categorical assignment of traits, morals, values, or characteristics based solely on race or sex. Public schools in this state shall be prohibited from engaging in race or sex-based discriminatory acts by utilizing these methods, which result in treating individuals differently on the basis of race or sex or the creation of a hostile environment.
- (b) **General.**
- (1) **Definitions.**
    - (A) “Public School” means the board of education of a school district, charter school, virtual charter school or otherwise accredited school, as defined and provided for in 70 O.S. § 1-108, 70 O.S. § 3-132, 70 O.S. § 3-145.3 and 70 O.S. § 3-104, respectively.
    - (B) “Course” means any forum where instruction or activities tied to the instruction are provided, including courses, training, seminars, professional development, lectures, sessions, coaching, tutoring, or any other class.
    - (C) “Teacher” has the same meaning as defined in 70 O.S. § 1-116.
  - (2) **Applicability.** As expressly set forth in 24 O.S. § 24-157(B), this rule shall apply to any Teacher, administrator or other employee of a Public School.
  - (3) **Nondiscrimination.** Nothing in this rule shall be intended to prohibit a Public School from employing lawful methods to address discrimination consistent with the requirements of the Equal Protection Clause of the Fourteenth Amendment, Title VI of the Civil Rights Act of 1964 (“Title VI”), Title IX of the Education Amendments of 1972 (“Title IX”), and 70 O.S. § 24-157. Further, nothing in this rule shall interfere or impair a Public School under a court order of desegregation.
  - (4) **Severability.** If any specific provision of this rule or its application to any person or Public School is held invalid, the remainder of the rule or the application of its provisions to any school, person, practice or entity shall not be affected.
  - (5) **Instruction.** Nothing in this rule shall be construed to prevent the teaching of history, social studies, English language arts, biology or any other subject matter area consistent with the Oklahoma Academic Standards as adopted and approved by the State Board of Education and approved by the Oklahoma Legislature.
  - (6) **Title IX of the Education Amendments of 1972.** Nothing in this rule shall be interpreted to prohibit the lawful consideration of sex, as authorized by Title IX, which permits distinctions and/or classifications based on sex in specific circumstances. This includes but is not limited to the provision of single-sex programs, the establishment of separate sex facilities (bathrooms and locker rooms) or sex-specific athletic teams, consistent with the requirements of Title IX and its implementing regulations at 34 C.F.R. Part 106.
- (c) **General Prohibition.** No teacher, administrator or other school employee shall require or make part of any Course offered in a public school the following discriminatory principles:
- (1) One race or sex is inherently superior to another race or sex,
  - (2) An individual, by virtue of his or her race or sex, is inherently racist, sexist or oppressive, whether consciously or unconsciously,
  - (3) An individual should be discriminated against or receive adverse treatment solely or partly because of his or her race or sex,

- (4) Members of one race or sex cannot and should not attempt to treat others without respect to race or sex,
  - (5) An individual's moral character is necessarily determined by his or her race or sex,
  - (6) An individual, by virtue of his or her race or sex, bears responsibility for actions committed in the past by other members of the same race or sex,
  - (7) Any individual should feel discomfort, guilt, anguish or any other form of psychological distress on account of his or her race or sex, or
  - (8) Meritocracy or traits such as a hard work ethic are racist or sexist or were created by members of a particular race to oppress members of another race.
- (d) **Specific Prohibitions Ensuring Compliance.** To ensure compliance with 70 O.S. §24-157(B) and to not discriminate on the basis of race or sex, as a part of any Course or activities, the following requirements shall apply to Public Schools, any Teacher, administrator, other employee, or other individual, group or representative of a Public School:
- (1) Public schools in this state shall be prohibited from providing, contracting to provide, offering or sponsoring any Course(s), as defined in subsection (b)(1)(B), that includes, incorporates, or is based on discriminatory practices identified in section (c).
  - (2) Public schools in this state shall be prohibited from using any monies, property, or any other assets or resources to engage in race or sex-based discrimination, including discriminatory practices identified in section (c).
  - (3) Public schools in this state shall be prohibited from adopting programs or utilizing textbooks, instructional materials, curriculum, classroom assignments, orientation, interventions, or counseling that include, incorporate or are based on the discriminatory concepts identified in subsection (c).
  - (4) Public schools in this state shall be prohibited from executing contracts or agreements with internal or external entities, persons, companies or businesses to provide services, training, professional development, or any other assistance that includes, incorporates or is based on discriminatory practices identified in section (c).
    - (A) Within sixty (60) days of the approval of this rule, existing contracts or agreements executed by public schools that conflict with this requirement shall be amended to come into compliance with this section. Contracts or agreements executed solely to provide services prohibited by 70 O.S. §24-157(B) or sections (c) or (d) of this rule shall be cancelled or terminated, consistent with the terms of the contract and applicable law.
  - (5) Public schools in this state shall be prohibited from receiving or applying to receive any monies that require, as a condition of receipt, the adoption of a Course(s), policies, curriculum, or any other instructional material that includes, incorporates or is based on discriminatory practices identified in subsection (c).
  - (6) Public schools in this state shall be prohibited from adopting diversity, equity, or inclusion plans that incorporate the concepts identified in subsection (b). Diversity officers in public schools shall be prohibited from providing any service or performing duties that include, incorporate, or are based on discriminatory practices identified in subsection (c).
  - (7) Public schools shall be prohibited from mandating diversity training that includes, incorporates or is based on discriminatory practices identified in subsection (c). This includes providing such training to employees, contractors, staff members, parents, students, or any other individual or group.
  - (8) Public schools in this state shall be prohibited from adopting policies, including

grading or admissions policies, or providing any other benefit or service that applies to students or any school employee differently on the basis of race or sex, unless specifically permitted by Title IX. (See (b)(6)). This prohibition includes segregated classes, programs, training sessions, extracurricular activities, or affinity groups unless otherwise permitted by Title IX. (See (b)(6)).

(e) **Parents Rights.** Parents and legal guardians of students enrolled in Public Schools in this state shall have the right to inspect curriculum, instructional materials, classroom assignments, and lesson plans to ensure compliance with 70 O.S. §24-157(B). Consistent with 20 O.S. § 2001-2002, no public school shall interfere with or infringe upon the fundamental rights of parents to determine their child's education.

(f) **State Department of Education and State Board of Education.** To ensure the compliance with the requirements of 70 O.S. §24-157(B), as a part of any Course, the following requirements shall apply to the State Board of Education and the State Department of Education, respectively:

(1) The State Board of Education shall be prohibited from mandating state standards or promulgating any rule that is based on, includes or incorporates discriminatory concepts of race or sex-based discrimination, including concepts identified in section (c).

(2) The State Department of Education shall be prohibited from providing resources, instructional support, courses, training, seminars, professional development, or any other class to public schools that is based on, includes or incorporates discriminatory concepts identified in section (c). This prohibition includes executing contracts or agreements with external entities, persons, companies or businesses to provide services, training, professional development, or any other assistance that includes, incorporates or is based on discriminatory practices identified in section (c) to public schools under the supervision of the Oklahoma State Board of Education and State Department of Education.

(3) The State Department of Education shall be prohibited from receiving or applying to receive any monies that require, as a condition of receipt, the adoption of programs, policies, curriculum, or any other instructional material that includes, incorporates or is based on discriminatory practices identified in subsection (c).

(g) **Public School Policies and Investigations.** To ensure compliance, public schools shall be required to adopt policies and procedures, including incorporating into employee and student handbooks, the requirements of 70 O.S. §24-157(B) and this rule. A public school's policy developed pursuant to this section must specifically notify individuals of the right to file complaints under subsections (g) of this rule. Public schools shall ensure that the parent or legal guardian of all students enrolled in the school are annually notified of the non-discrimination requirements in 70 O.S. §24-157(B) and this rule.

(1) Public schools shall be required to develop a process for students, parents, teachers, school staff, and members of the public to file a complaint alleging a violation of the provisions of 70 O.S. §24-157 or this rule. In order for a complaint to be accepted for investigation, it must:

(A) Be submitted in writing, signed and dated by the complainant, including complaints submitted through electronic mail that include electronic signatures;

(B) Identify the dates the alleged discriminatory act occurred;

(C) Explain the alleged violation and/or discriminatory conduct and how 70 O.S. §24-157 or the provisions of this rule have been violated;

(D) Include relevant information that would enable a public school to investigate the alleged violation; and

(E) Identify witnesses the school may interview, if applicable, provided the

school will not dismiss a complaint for failure to identify witnesses.

(2) Public schools shall be required to designate at least one employee to receive reports of violations filed by students, parents, teachers, school staff, or members of the public. Public schools shall identify the employee(s) responsible for receiving complaints in policies and materials published pursuant to section (g).

(A) The contact information of employee(s) responsible for receiving complaints, including telephone and e-mail, shall be included in the policies and materials adopted pursuant to section (g) and shall be made publicly available on the public school's website.

(B) The employee(s) responsible for receiving complaints pursuant to this section shall notify the complainant that the complaint has been received and whether it will be investigated within ten (10) days of receipt.

(3) Public schools shall be required to investigate all legally sufficient complaints that meet the requirements of subsection (g)(1) and make a determination as to whether a violation occurred. A public school must conclude the investigation of a complaint filed pursuant to subsection (g)(1) within ninety (90) days of receipt.

(A) A complainant shall be notified in writing of a final determination, including the public school's findings of whether a violation occurred.

(B) It is permissible for a public school to receive, process, and investigate complaints filed under this subsection in the same manner in which the public school processes and investigates all other complaints of discrimination, provided the public school notifies a complainant pursuant to subsection (g)(2)(ii), reaches a final determination in the investigation within ninety (90) days of receipt of the complaint pursuant to subsection (g)(3) of this rule and complies with subsection (g)(3)(i).

(4) A complainant may file a complaint alleging a violation of 70 O.S. §24-157 or this rule directly with a public school pursuant to subsection (g)(1) of this rule or may file a complaint directly with the State Department of Education pursuant to subsection (h)(2) of this rule provided:

(A) A complainant may not file complaints simultaneously with a public school and the State Department of Education;

(B) The State Department of Education may not require a complainant to first file with a public school prior to seeking relief pursuant to (h)(2); and

(C) Any complainant who believes that a public school has incorrectly refused to investigate a complaint or has evidence that a public school has reached an incorrect determination may subsequently file a complaint with the State Department of Education pursuant to subsection (h)(2) of this rule.

(h) **Accreditation.** Consistent with State Board of Education's authority under 70 O.S. § 3-104.4 (I)(5), public schools in this state shall be evaluated annually to ensure compliance with 70 O.S. §24-157(B) and the requirements of this rule.

(1) **Public School Application for Annual Accreditation.** Consistent with the provisions and requirements of OAC 210:35-3-201, a school's failure to comply with 70 O.S. §24-157(B) or any requirement in this rule shall, at a minimum, result in the accreditation status of the public school being classified "Accredited With Deficiency." The public school shall have one school year to correct deficiencies.

(A) A public school that fails to correct deficiencies after being classified as "Accredited With Deficiency" for violations of 70 O.S. §24-157(B) or any requirement in this rule shall be classified, at a minimum, "Accredited With

Probation” in the second year of noncompliance for “deliberately and unnecessarily violating one or more regulations.” (See OAC 210: 35-3-201(b)(4)C)). The public school shall have one school year to correct deficiencies.

(B) A public school that fails to correct deficiencies after being classified as “Accredited With Probation” for violations of 70 O.S. §24-157(B) or any requirement in this rule shall be classified “Nonaccredited” in the third year of noncompliance consistent with Oklahoma statutes and the State Board of Education’s administrative rules, processes and procedures. (See OAC 210: 35-3-201).

(2) **Investigation and Immediate Action.** Consistent with the requirements of 70 O.S. § 3-104.4, the Department shall investigate any complaint of any failure to comply with accreditation standards, including compliance with 70 O.S. § 24-157(B) or any requirement in this rule. If the Department determines that a public school has failed to comply with the accreditation standards, including this rule, the Department shall report the information to the State Board for further action, and within the timeline, provided in 70 O.S. § 3-104.4.

(i) **Public Reporting.** Public School employee(s) designated pursuant to subsection (g)(2) shall be required to report for each complaint filed pursuant to subsection (g)(1) to the State Department of Education within thirty (30) days of resolution of the complaint. The State Department of Education shall report quarterly to the State Board of Education on complaints filed pursuant to subsection (f), including:

(1) The number of complaints filed with Public Schools;

(2) The number of complaints dismissed or not investigated;

(3) The number of complaints opened for investigation;

(4) The number of cases where, following a full investigation, the Public School determined that a violation occurred; and

(5) The number of cases where, following a full investigation, the Public School determined no violation occurred.

(6) The number of cases where, following a full investigation, the State Department of Education has determined that a violation occurred or did not occur.

(j) **Suspension or Revocation.** Consistent with OAC 210:1-5-6 and subsection (b)(1)(iii), the provisions of this rule shall apply to superintendents of schools, principals, supervisors, librarians, school, classroom teachers or other personnel performing instructional, administrative and supervisory services in the public schools.

(1) **Suspension.** As a part of its investigation of a legally sufficient complaint filed pursuant to subsection (g), the State Department of Education shall make a determination of whether to initiate proceedings to suspend the license or certificate of any school employee who is found to have violated 70 O.S. §24-157(B) or any provision of this rule, consistent with the State Board’s processes and procedures for suspension of certificates.

(2) **Grounds for Revocation.** Consistent with OAC 210:1-5-6, subsection (b), the State Board of Education shall initiate proceedings to revoke the license or certificate of any school employee for “willful violation” of 70 O.S. §24-157(B) or any requirement in this rule. (See OAC 210: 1-5-6(b)(1) - (b)(2)). The requirements and processes outlined in OAC 210:1-5-6, including the rights afforded to certificate holders, shall apply to all revocation proceedings.

(k) **Retaliation.** Consistent with the provisions of Title VI and Title IX, no individual shall be retaliated against for: 1) filing a complaint pursuant to subsections (g)(1) or (h)(2) of this rule; or 2) the purpose of interfering with any right or privilege secured by federal civil rights laws and regulations. Any school employee who retaliates against a complainant shall be

subject to disciplinary action pursuant to subsection (j) of this rule.

(l) **Whistleblower Protection.** Any Teacher who files a complaint pursuant to subsection (g)(1) or (h)(2) of this rule or otherwise discloses information the teacher reasonably believes evidences a violation of 70 O.S. §24-157(B) or this rule shall be entitled to the Whistleblower Protections in applicable laws, including those at 70 O.S. § 6-101.6b.

(m) **False Reporting.** Any Teacher or other school employee who, willfully, knowingly and without probable cause make a false report pursuant to subsection (g)(1) or (h)(2) of this rule may be subject to proceedings pursuant to subsection (j) of this rule.

(n) **Complaints by School Staff.** Any school employee who is discriminated against by a public school in the form of race or sex based harassment, bias, stereotyping, scapegoating, classification, or the categorical assignment of traits, morals, values, or characteristics based solely on race or sex in violation 70 O.S. §24-157(B), may file an employment discrimination complaint with the Oklahoma Attorney General's Office of Civil Rights Enforcement pursuant to 25 O.S. § 1101, *et seq.*

(o) **Relief.** Title VI and Title IX may be enforced by private right of action, whereby aggrieved parties may seek relief, including monetary damages, for violations of federal antidiscrimination laws. Victims of discrimination may file a lawsuit directly against the Public School. In addition to any private rights of action, aggrieved parties may seek applicable remedies through the U.S. Department of Education's Office for Civil Rights or the U.S. Department of Justice's Civil Rights Division.



# OPSRC

Oklahoma Public School Resource Center



## *The land of opportunity.*



If the 2020 session posed unprecedented challenges due to COVID, the 2021 session presented unprecedented opportunities. Policymakers were equipped with real stories surrounding equitable access to education and the needs of families across the state. Some responses came early, like the use of federal relief funds to provide technology and supplies for healthy learning environments. Other responses emerged after a state budget had been approved, freeing up more relief funds for programs like the State Department's Counselor Corps Initiative. The Oklahoma Legislature took a more aggressive approach on the expansion of broadband to rural areas and inclusion of mental health instruction in all health curriculum.

Some big accomplishments were made this year. Funding increased for education in Oklahoma when many other states were forced to cut budgets. A foundation has been laid to further examine the efficacy of teacher preparation and development. Instruction on health will be provided to all students. For the first time in state history, state revenues will be used to help schools with capital projects.

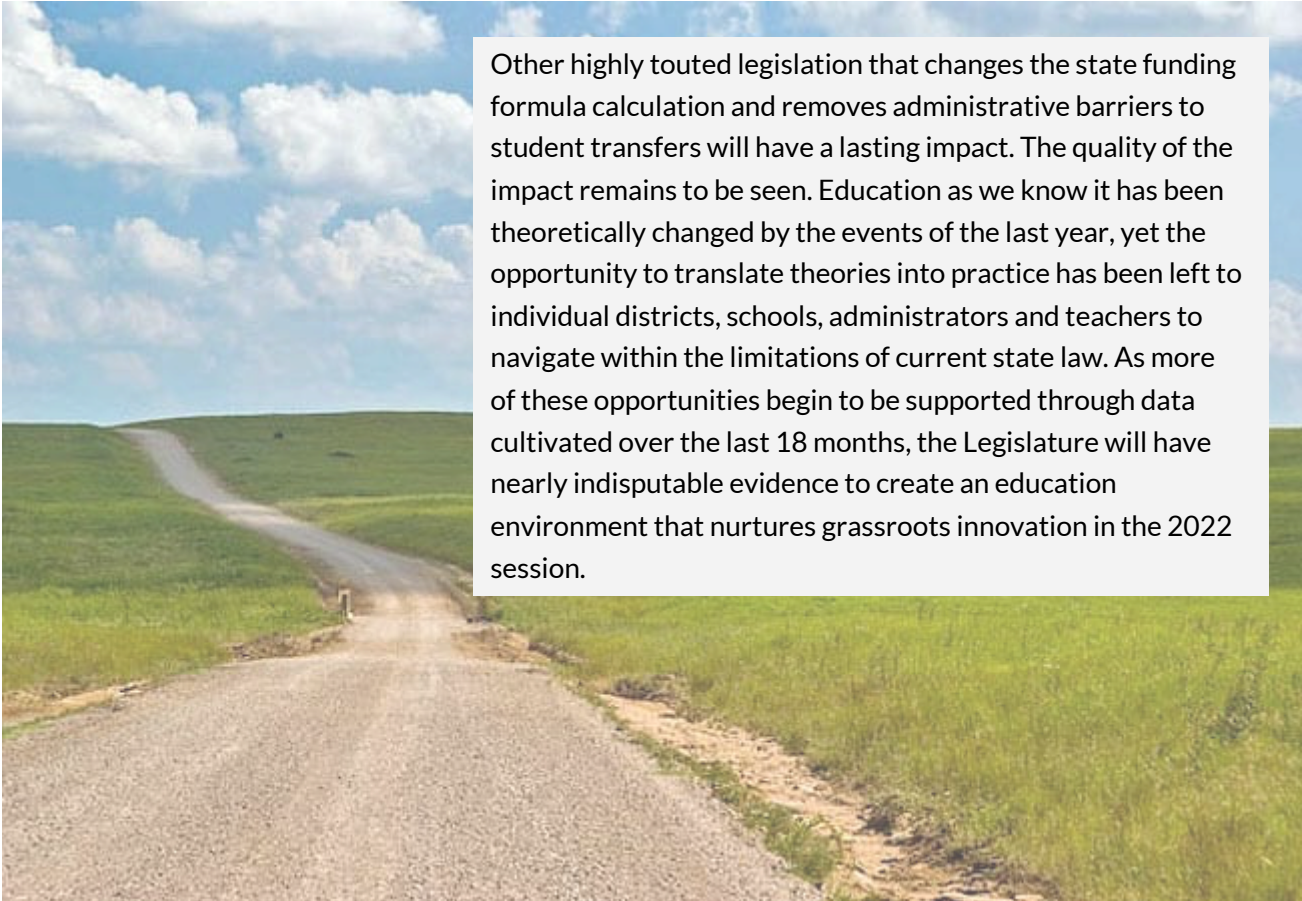
A photograph of a gravel road winding through a green field. The road is made of light-colored gravel and curves to the right. The field is lush green, and the sky is blue with white clouds.

Other highly touted legislation that changes the state funding formula calculation and removes administrative barriers to student transfers will have a lasting impact. The quality of the impact remains to be seen. Education as we know it has been theoretically changed by the events of the last year, yet the opportunity to translate theories into practice has been left to individual districts, schools, administrators and teachers to navigate within the limitations of current state law. As more of these opportunities begin to be supported through data cultivated over the last 18 months, the Legislature will have nearly indisputable evidence to create an education environment that nurtures grassroots innovation in the 2022 session.



# FINANCE

The state budget proved to be in better shape than what was expected this time last year due, at least in part, to an infusion of pandemic-related federal relief funds. We know that isn't the end of the story for school funding. Despite an increase in State Aid of approximately \$113 per weighted Average Daily Membership (ADM), the uptick requires state revenue collections to be at or above the projected dollar figure to ensure schools receive the promised amount. Governor Stitt expressed some concern after signing the FY2022 budget into law that legislators had overspent, primarily due to legislation passed this session that will have a marked impact on future revenue collections.

The education budget saw both a general increase and an increase in targeted funds. Schools will have money to purchase new, standards-aligned science textbooks, and many districts will receive funding from the state toward capital projects. The future of funding stability rests not only in the growth of the state economy but in legislation passed this session that is projected to cost the 1017 Fund, the primary source of dedicated education revenue, [nearly \\$300 million](#).

## *Funding Formula Change: HB2078*

While this change does not impact school funding for the next school year, it will for the next ensuing school year. Currently, State Aid is calculated using the highest weighted ADM (WADM) of either (1) the current year's first nine weeks, (2) the previous year or (3) the year immediately preceding the previous year. This measure eliminates option (3), most commonly referred to as the **"three-year high."** This new calculation begins in the summer of 2022 for the 2022-23 school year. WADM will be based on the higher of the first nine weeks of 2022-23 or the final count of 2021-22. Districts with higher-than-normal counts for the 2020-21 (pandemic) school year will likely see a loss, along with districts that have seen declining enrollment for several years; however, their losses will be much more immediate than in the past. The intent of the legislation is to make sure "funding more closely follows the student." It does not take into account an uptick in enrollment after October 1, and there may be a lag in funding for students taking advantage of the new open transfer legislation that was also passed this session.

*Using current numbers, OPSRC projects 284 districts will see an increase in State Aid, 38 districts will see no change and 219 will see a decline. Charter schools are included in these counts. The largest projected decrease*

will be in the Oklahoma City Public School District, whose loss is nearly double that of the next largest decrease in the Mid-Del District.

### Projected Changes in State Aid due to HB2078

Red=decrease Green=increase

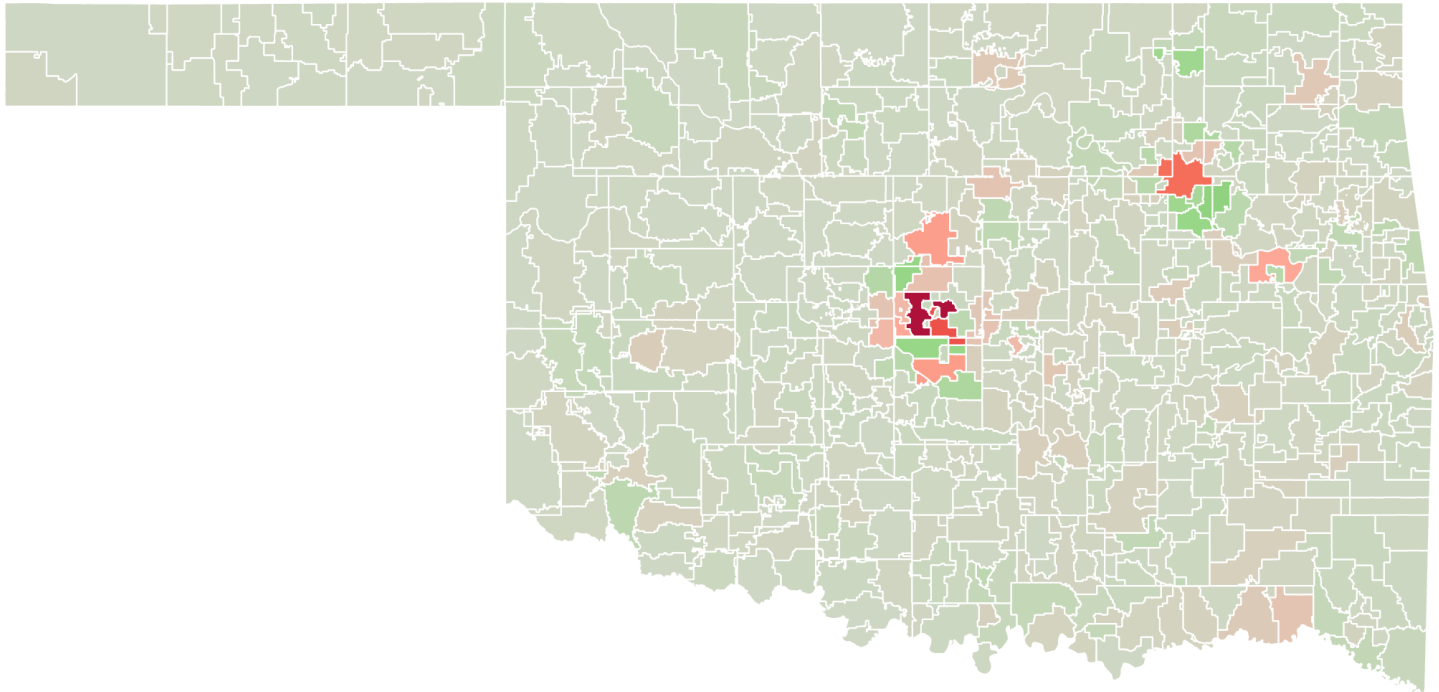

### Carryover Penalties Waived: HB2890

Because of HB2078 and previously adopted legislation during the 2020 session, districts have a bit more breathing room on carryover funds. **No carryover penalties will be assessed** until FY2026 (or the school year ending in 2025). This should help schools temporarily mitigate negative impacts from the funding formula change, provided they have substantial funds for carryover.

### State Revenue for Capital Projects: SB229

Until this legislative session, Oklahoma was one of only a handful of states that provided no state revenue toward capital projects. This measure is the culmination of efforts over the last few years to reinvigorate interest in the State Public Common School Building Equalization Fund, a constitutional fund established by statewide voters in the 1980's to equalize building funds across districts with low ad valorem and provide some property tax relief. Unfortunately, neither voters nor the state established a revenue stream for the fund. This measure does just that. It creates a formula to calculate the statewide average local funding per student and provides a grant to bring all schools under that average up to it. The revenue comes from the state retail sales tax on medical marijuana already dedicated to education, again, by the voters. The annual allocation for funding needs is expected to fluctuate, relying heavily on how much districts actually collect in local ad valorem. Charter schools will receive the largest grants year over year, as this measure further eliminates them from accessing local dollars. The money

allocated for these Redbud Grants will be used to calculate state funding towards a trigger to reinstate class size mandates beginning this school year with kindergarten and first grade. The measure takes effect this school year and will be calculated on prior year average daily membership.

### *Federal Relief Funding*

SB1037 allows districts to **place federal relief funds into their building fund accounts**. Once placed in a building fund, the relief funds cannot be removed.

SB2932 stipulates that state agencies and other political subdivisions **cannot use CARES Act funds in a manner that would require future state appropriations** for continuation or maintenance without the approval of the legislature. Certain programs put into place by the State Department of Education and the Statewide Virtual Charter School Board could be prohibited from future appropriations under this newly enacted law without continuing legislative approval.

### *Finance Operations*

HB1968 **removes a duplicative reporting requirement for school gifted and talented expenditures**. Previously, districts reported the expenditures in both OCAS and by providing a physical report to the State Department. The latter will no longer be required.

SB22 requires school boards to give lessees of physical and real district property the **right of first refusal to purchase the property** at fair market value should the board choose to dispose of the property.

SB1080 **expands the cap for the Equal Opportunity Scholarship** to \$25 million for donations to organizations granting scholarships for private schools and \$25 million for donations to public schools. In addition, the measure expands access to the \$25 million in tax credits from rural districts to all districts and approved school foundations. Districts are limited to \$200,000 in tax credits each tax year. This measure will take effect January 1, 2022.

### *Compensation*

SB807 requires **support personnel be paid for lost wages** in the event a school is closed due to a pandemic or by an authorized health official. This measure is not retroactive but could become important in the fall as projections indicate increases in both active COVID and flu cases.

SB1038 allows **student teachers to receive pay on the first day** of their internship. Pay received while interning does not count toward salary schedule steps or retirement. The measure also establishes that the EQA and the Regents bear responsibility for designing the teacher intern program rather than the institution at which the student is enrolled. This goes into effect beginning this school year.

SB267 allows **retired teachers to return to the classroom at full pay** for up to three years, ending July 1, 2024. This only applies to those who have retired and received OTRS benefits for one full year as of July 1, 2020.



The Legislature continued the previous year’s work on improving teacher certification and professional development flexibility. We know the work teachers and school personnel have put in has been challenging and more difficult than anyone could have ever predicted. Providing these flexibilities will ensure teachers are able to personalize their own career development pathways and assist those new to the field in honing their skills.

Oklahoma is no stranger to the ongoing national teacher shortage. Nearly 1,000 teachers retired in FY2020, with many more leaving the classroom due to the stress of multi-platform teaching and their own family obligations. The state continues to fill these positions with career professionals outside education. As of June 2021, 2,277 individuals have requested emergency certificates this year, meaning districts have been unable to fill critical positions with fully certified staff. Of these requests, 1,563 are seeking emergency certification in areas not currently covered by their certification. Compounding the issue are the 655 individuals renewing their emergency certification indicating that, while they may be working toward full certification, they have not completed requirements.

The Legislature is likely to continue providing more credentialing flexibility in future sessions. Our hope is that they include meaningful, personalized pathways for our teachers to show their expertise and grow in their fields.

### Alternative Certificates for Early Childhood and Elementary Education: HB2748

Beginning November 1, 2021, teaching candidates will be able to apply for an **alternative teaching certificate in early childhood and elementary education**, renewable up to three years. Candidates must have a specific terminal degree or a bachelor’s degree and two years related work experience to qualify.

Number of Emergency Teaching Certificates Issued by Year

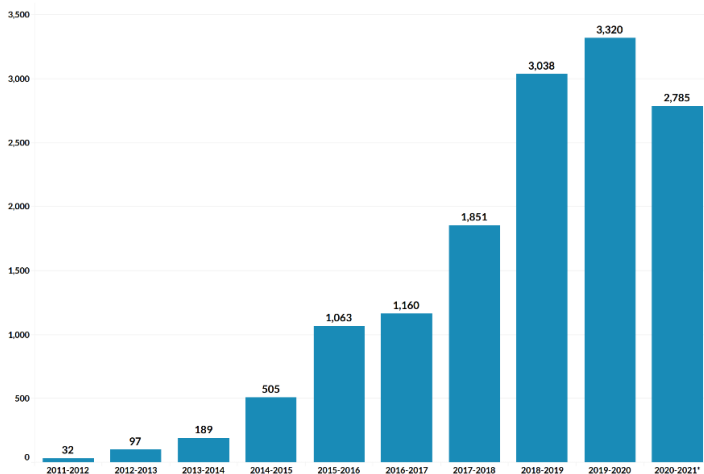

\*As of March 2021  
Data Source: Oklahoma State Department of Education

### Flexibility in Subject Area Endorsements

HB1796 allows **exceptions to subject area examinations** for initial certification in subject areas where the candidate holds an advanced degree in a similar field of study. This does not apply for subject areas that require specific graduate programs of study such as specialist certifications.

HB2752 directs the SDE and EQA to develop a **microcredential program for computer science and**

**STEM endorsements** to be an option in place of the subject area examination. Microcredentials are modules of self-paced study that are focused on mastering concepts and instructional coaching.

### *Other Certification*

HB2329 directs the State Board to grant **certification exemptions for teaching candidates who are deaf** and intending to teach in an environment where American Sign Language is the language of instruction.

### *Retirement*

SB683 provides an opportunity for nonclassified, optional personnel to **opt out of participation in the Teachers Retirement System (OTRS)**. If personnel do not opt out within 30 days of hire, they will automatically be enrolled in the system. Current eligible employees will have 30 days from July 1, 2021, to opt out.

HB2293 directs the OTRS Board of Trustees to set **two different employer contribution rates**. The first is the rate for standard school year employment. The second rate, which shall be no more than one half of the standard rate, shall apply to contributions for a contracted summer school teacher.

### *Professional Development*

HB1593 **changes the timetable for completion of certain annual professional development requirements**. Beginning November 2021, professional development on digital teaching and learning standards and incorporating workplace safety into instruction for 7<sup>th</sup>-12<sup>th</sup> grade students shall be offered in a teacher's first year of employment and then on a schedule to be determined by the local board. Professional development on recognizing and addressing the mental health needs of students and identifying drug and alcohol abuse shall also take place in a teacher's first year of employment and subsequently once every three years.

HB2749 provides that beginning in the 2022-23 school year, any district that receives more than \$2,500 in Reading Sufficiency Act funds shall use no less than 10% of funds to **provide professional development on the science of reading** for prekindergarten through 5<sup>th</sup> grade teachers.

### *Teacher Preparation Programs*

HB1773 requires preservice teacher preparation programs in Oklahoma universities to include instruction on the framework, components and implementation of multi-tiered systems of support. This includes instruction on the impact of trauma and trauma-informed instruction.



# OPERATIONS

The day-to-day functions that keep things running smoothly--and the staff committed to making it work--are foundational not only to the learning environment but also to the public perception of education. Most legislative changes to operational functions are small but can lead to big administrative headaches when implemented. We prefer to see those measures that remove arbitrary administrative hurdles, and we did see some of that this session. However, the biggest operational change enacted this session is the change to processing student transfer requests. We put this under the heading of operations because the known impact of the measure will surely require a lot of thoughtful planning in school operations. The unknown impact is how the ability to (nearly) freely transfer between districts will impact students.

## *Open Transfers: SB783*

This measure allows a student to transfer to up to two non-resident school districts per year without the requirement that the sending district approve of the move, beginning January 1, 2022. It requires districts establish a capacity policy for each school and grade. Schools will be required to fill any open seats with students requesting a transfer on a first-come, first-served basis. The new law permits the denial of transfer for students with a history of absenteeism, drug or weapon-related offenses or violent offenses. Denial of a transfer is appealable to the local board and, if denied again, to the State Board. Schools will report the number of openings on their websites and to the SDE four times per year.

## *Other Operations Changes*

Most legislative changes to school district and board operations are easy to understand and do not require a long summary. We have laid out those changes in the following table with their effective dates, the date the law took effect and their implementation dates (or when these changes have to take place on the school, district or board level).

Bill Number	Effective Date	Implementation Date	Changes to Current Practice
HB1014	04/20/2021	04/20/2021	Records created or held by the State Department of Health are not subject to Open Records. It is up to the school and the parent/guardian of student to enforce isolation or quarantine for students exposed to communicable diseases.
HB1018	11/01/2021	N/A	The biennial school law book will no longer be published in physical form. It will still be accessible online.
HB1046	11/01/2021	No later than 11/01/2021	Districts must provide a link or a copy of their most recent audit on the homepage of their website.
HB1104	11/01/2021	No later than 11/01/2021	Schools will begin collecting tribal affiliation and Indian heritage data as part of student data collection.
HB1715	04/26/2021	04/26/2021	Schools will no longer have to provide proof that a student passed the 8 <sup>th</sup> grade reading test for the student to obtain a driver's permit or license.
HB1801	11/01/2021	Prior to the start of the 2021-22 school year	Schools must collaborate with local emergency responders to create emergency action plans for athletic events.
HB1875	05/10/2021	05/10/2021	Educational institutions cannot release or sell student directory information of which it is not the primary custodian.
HB1876	05/03/2021	05/03/2021	Current and former personnel private contact information cannot be released pursuant to an Open Records request.
HB1963	11/01/2021	11/01/2021	The governor may appoint local school board members if a vacancy would result in an inability to make quorum.

HB2223	11/01/2021	11/01/2021	Requires the SDE to maintain and regularly update the Dyslexia Handbook.
HB2462	04/23/2021	04/23/2021	SDE can maintain an account to pay for conferences and trainings.
HB2691	07/01/2021	Report due 10/30/2021	Creates a report on factors that improve public education from PreK through higher education or vocational training.
SB13	07/01/2021	07/01/2021	A teacher must be placed on suspension if their license or certificate has been placed on suspension by the State Board while due process proceedings are pending.
SB54	11/01/2021	11/01/2021	Creates a special designation for schools that provide services to military-connected students.
SB68	07/01/2021	07/01/2021	Extends the residency verification window for military-connected students moving due to active orders (traditional districts).
SB69	07/01/2021	07/01/2021	Extends the residency verification window for military-connected students moving due to active orders (statewide virtual charter schools).
SB121	07/01/2021	07/01/2021	Districts must adopt a policy to provide safe, clean and secure lactation rooms for employees and provide paid breaks for lactating employees.
SB128	04/26/2021	Personnel trained by 01/01/2022  Seizure Action Plans begin on effective date	Each school site must have at least one person trained to recognize symptoms of seizures and administer seizure rescue medications. Each student with a history of seizures must have an action plan on file.
SB302	07/01/2021	07/01/2021	Visiting athletic teams must have the same rights to stream or broadcast athletic

			events as home teams as long as a student program or media contract is in place.
SB347	05/05/2021	05/05/2021	Elections cannot be held until April 2022 to allow for redrawing of precincts after statewide redistricting.
SB658	07/01/2021	07/01/2021	Districts must provide immunization exemption information on their websites. Instituting specific requirements for mask and medical device mandates. Prohibits such mandates unless the district is in a county under an emergency order. Districts cannot require any immunization not approved by the Legislature.
SB783	03/31/2021	Capacity policy set and transfers may begin on 01/01/2022.	Open Transfers (see above description)



The Legislature has a significant impact on what happens inside a classroom, from the physical resources available to the curriculum that aligns with the state standards, which are also approved or disapproved by the Legislature. Up until now, legislators did focus more on the “what” rather than the “how,” recognizing that a state mandate of how a teacher instructs would be difficult to monitor. HB1775 speaks directly to how teachers teach about biological sex and race within the walls of their classrooms. With the signing of this bill, Oklahoma joins Idaho, New Hampshire, Iowa, Tennessee and Texas in greatly limiting discussions on certain “divisive topics” as part of classroom instruction.

Other legislation directly impacting students’ instruction focuses on physical and mental health. Legislation sets a course to provide health instruction to all students to address some of the negative aspects of the state’s health and ACE statistics.

Included in the following summaries are measures that impact post-secondary and higher education pathways. Reports have indicated more students opted to delay higher education studies due to the pandemic, the effects of which will not be realized for several years. In response to rising costs of higher education, legislators attempted to provide a cursory exposure to other post-secondary opportunities.

### *Student Physical and Mental Health*

HB1103 requires schools to administer the **Oklahoma Needs Prevention Survey** biennially to all 6<sup>th</sup>, 8<sup>th</sup>, 10<sup>th</sup> and 12<sup>th</sup> grade students, contingent on federal funding. The survey is developed in conjunction with the Department of Mental Health which will provide support to schools in developing programs to meet their students’ specific needs.

SB21 requires that every district to provide training to all staff annually on **suicide prevention and awareness** and student alcohol and drug abuse, beginning with the 2021-22 school year. Districts may elect to provide similar training to students in grades 7-12.

SB89 requires that beginning with the 2023-24 school year, all students must receive **health education instruction**. Schools may elect to incorporate the forthcoming standards into existing classes or provide stand-alone courses. All teachers providing a stand-alone course must be properly credentialed.

HB1568 requires all physical health instruction to incorporate components of **mental health** and how physical and mental health are interconnected.

### *Civics Instruction*

HB2030 requires that beginning with the 2021-22 freshman class, all students must pass the **U.S. Naturalization Test** with a score of at least 60% in order to graduate. Schools may begin to provide the test to students in 8<sup>th</sup> grade and must provide an opportunity for students to test each year.

HB1775, which is applicable to all studies and all grades, focuses on history and civics instruction. It will have the most significant impact for teachers of these subjects along with any teacher who provides instruction on literature and elective courses focusing on **race or gender studies**. The measure prohibits teachers from incorporating studies on race and sex in a way that casts blame for oppression based solely on the perpetrators' race or sex or could be construed to make a student feel shame or guilt regarding their own race or sex. A non-binding resolution, HR1038, was passed by the House that prohibits schools from mandating professional development on critical race theory, Project 1619 or "other issues" as provided by HB1775. The resolution did not have to be approved by the Senate or Governor Stitt.

### *Early Childhood and Elementary Education*

HB1569, developed by teachers across the state, encourages early childhood and elementary education teachers to adopt methods of instruction that focus on **student-led play-based learning**. It directs that professional development may be offered and that no administration may prohibit the use of this method.

### *After-school Task Force*

HB1882 creates a task force to examine the **availability, quality and affordability of existing out-of-school time programs across the state**. The last year has shed a blinding spotlight on the lack of programming for students outside of their regular school day, beyond the need for basic childcare. Parents and guardians are getting some respite this summer due to an infusion of federal dollars directed at summer programming. The task force is charged with providing a report on ways to increase availability of these programs and includes representatives from a variety of areas.

### *Computer Science*

SB252 requires that beginning with the 2024-25 school year, all secondary schools must provide at least one **computer science course** and all other schools must incorporate computer science instruction. A significant portion of future available jobs will require at least basic knowledge in this area. The measure requires the SDE to track the availability and enrollment in such courses and provide a public report.

HB2750 addresses some concerns regarding acceptance of **Advanced Placement scores** for college credit at Oklahoma institutions. It expresses the Legislature's intent for institutions to provide basic course credit beginning with a score of 3. Each institution must develop a credit policy and make it available on the institution's website.

SB132 expands **OHLAP enrollment** eligibility to students in the 11<sup>th</sup> grade.

SB619 allows students who are at least 16 years of age to participate in **apprenticeships, mentorships and internships**. These programs may be offered off site. Districts may elect to purchase liability policies to cover students during these activities.

SB639 allows OHLAP funds to be used for **certification programs leading to careers in designated "critical needs" areas**. These areas are determined by the state Department of Commerce and are based on projections of job availability.

SB642 directs schools to provide an annual opportunity to **take the ASVAB during the school day**.

As always, we thank you for allowing us to serve your school community and appreciate your feedback. Nearly 100 pieces of legislation are included in this summary, yet many more will have an impact on education in our state. At the conclusion of this writing, the Legislature published a list of studies that will examine everything from school accountability to teacher credentialing over the course of the coming months. We will keep you updated as those take place and as administrative rules are processed implementing the bills described here.

Education policy is a constantly changing field. Terms like "data-driven" and "expert-proven" have relevance, but we cannot lose sight that within this gigantic, often unwieldy system are kids who have very specific needs who don't get "do-overs" and highly trained professionals employed to meet those needs. Change is incremental and is dependent on a symphony of long-term advocates.

The background of the entire page is a photograph of the Oklahoma State Capitol building, featuring its prominent dome and classical columns. The image is overlaid with a semi-transparent brown vertical bar on the left side.

# LEGISLATIVE REVIEW

2021



A PUBLICATION OF THE OKLAHOMA STATE SCHOOL BOARDS ASSOCIATION

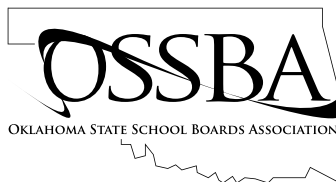

**©2021 Oklahoma State School Boards Association. All rights reserved.**  
**A publication of the Legal Department of the Oklahoma State School Boards Association**  
2801 North Lincoln Boulevard, Suite 125 • Oklahoma City, OK 73105  
405.528.3571 • 888.528.3571 • 405.528.5695 fax • [www.ossba.org](http://www.ossba.org)

## Budget

---

[HB 2900](#) is the general appropriations bill for FY 2022. The overall plan appropriates \$8.3 billion to state agencies. That is a 7.62% increase over last year's appropriations of \$7.7 billion.

Key takeaways for the FY22 budget:

- State aid appropriation – Increase of \$136.3 million (5.65% increase)
- Textbooks/instructional materials – \$60 million (double FY 21 amount)
- Redbud/Building Equalization Fund – Approximately \$38.5 million
- Public school activities – \$108.9 million (\$8 million increase)
- Total new investment – \$210+ million
- Career Tech – Increase of almost \$1.4 million

[SB 1067](#) outlines how the state Education Department can spend part of the education budget, also known as a “limits” bill. See the full breakdown [here](#). The biggest pieces are:

- \$2,437,246,699 for state aid
- \$704,456,047 for additional program areas
- \$15,027,640 for administrative and support functions of the Oklahoma State Department of Education
- Textbook money appropriated in monthly installments
- Total = \$3,156,730,386

[SB 229](#) by Sen. John Michael Montgomery, R-Lawton, and Rep. Kyle Hilbert, R-Depew, creates the Redbud Funding Act. Beginning with the 2021-2022 school year, school districts and charter schools will receive the equivalent of the state average of the per-student building fund and the 25% (1 mill) of the county 4-mill that is not chargeable. State Education Department estimates show school districts and charter schools will share nearly \$39 million in new revenue next school year. The bill also affirms charter schools are prohibited from receiving state-dedicated, county or local revenue and are not eligible to issue bonds. Based on estimates for the 2020-2021 school year from the Oklahoma State Department of Education, each school district and eligible charter school will receive a minimum of \$330.77 per student in FY 22:

- 309 traditional school districts will receive approximately \$34.5 million.
- 25 charter schools would receive \$4.4 million.
- Charters authorized by the statewide virtual board are not eligible.
- Money is apportioned from medical marijuana revenue.

**Effective May 28.**

## Transfers

---

[SB 783](#) by Rep. Brad Boles, R-Marlow, and Sen. Adam Pugh, R-Edmond, makes significant changes to the open transfer law, including eliminating emergency transfers and making it easier for students to transfer between school districts. By Jan. 1, 2022, school boards must adopt a new student transfer policy. Again, emergency transfers are eliminated. Beginning Jan. 1, districts must report publicly and to the state Department of Education (SDE) their capacity to accept transfers for each grade level at each school site by the first day of January, April, July and October. Data on the number of transfers by grade level and site must be reported to the SDE. Districts must also submit data to the SDE on transfer denials, including the reason for denial. Districts are required to accept transfers at any time of the school year subject to capacity limits. The local school board shall determine capacity based upon the district's policy. The Office of Educational Quality and Accountability (OEQA) will be required annually to randomly select 10% of school districts in the state and conduct an audit of each district's approved and denied transfers. If the OEQA finds inaccurate reporting of capacity levels by the district, they will then have the authority to set the capacity for the district. Transfers must be accepted in the order they are submitted. Transfers may only be denied if the district has exceeded its enrollment capacity or for student discipline or attendance issues. A student who applies for a transfer and whose parent/ guardian is an active member of the military or a member of the military reserve on active duty cannot be denied a transfer because of capacity limitations. Siblings may be granted a transfer as long as the school district has capacity and if the sibling is not otherwise disqualified due to attendance or misconduct, because the new law requires that all applications be considered in the order received. The transfers are for one year. A student may only transfer twice in one year (except foster students). If a district denies a transfer, the parent or legal guardian of the student has 10 days to appeal the denial to the local board of education. The board must consider the appeal at its next regularly scheduled board meeting if notice is provided prior to the statutory deadline for posting the agenda for the meeting. If notice is given after the deadline, the board must consider the appeal at a special meeting of the board of education. The appeal process will occur in executive session to protect student privacy. Schools may choose to consistently have a paper-only appeal process or an in-person appeal process. If the board upholds the denial, the parent or legal guardian may appeal the denial to the state Board of Education (SBE) within 10 days of receiving notice of the local board's decision. (SBT will develop rules for this process). Busing isn't required. Nothing changed with special education students. Also note that SB 783 does not impact current rules related to extracurricular activities. **Effective March 31. The changes would go into effect on Jan. 1, 2022.**

[SB 68](#) by Sen. Frank Simpson, R-Springer, and Rep. Max Wolfley, R-OKC, allows students, whose parents or legal guardians are on active military duty and are pending transfer or have been transferred to a military base within the state, to be considered in compliance with state residency provisions. It requires schools to accept electronic enrollment applications. Parents would be required to provide proof of residency, which could be a temporary on-base billeting facility, a purchased or leased home/apartment or federal government or public-private

venture off-base military housing, within 10 days after the published arrival date stated in the official enrollment documentation. **Effective July 1.**

[SB 69](#) by Sen. Frank Simpson, R-Springer, and Rep. Max Wolfley, R-OKC, allows students to enroll in statewide virtual charter schools if the parent or legal guardian has transferred or is pending transfer to a military base within the states. Virtual charter schools would be required to accept electronic enrollment applications and parents must submit, within 10 days after the published date of arrival, proof of residency, which could be temporary on-base billeting facility, a purchased or leased home/apartment or federal government or public-private venture off-base military housing. **Effective July 1.**

## Finance

---

[HB 2078](#) by Sen. Zack Taylor, R-Seminole, and Rep. Kyle Hilbert, R-Depew, will change the basis for state aid funding. Instead of using the highest weighted average daily membership from the current year or two prior years, districts will only use the highest weighted average daily membership from the current year or prior year. It also increases the allowable carryover in the general revenue fund of districts beginning in 2022-2023. **The change will go into effect with the 2022-2023 school year.**

- Allowable Less than \$1,000,000 from 40% 48%
- \$1,000,000 -\$2,999,999 from 35% to 42%
- \$3,000,000 -\$3,999,999 from 30% to 36%
- \$4,000,000 -\$4,999,999 from 25% to 30%
- \$5,000,000 -\$5,999,999 from 20% to 24%
- \$6,000,000 -\$7,999,999 from 18% to 22%
- \$8,000,000 -\$9,999,999 from 16% to 19%
- \$10,000,000 or more from 14% to 17%

[HB 2890](#) by Sen. Pemberton, R-Muskogee, and Rep. Kevin Wallace, R-Wellston, corrects an issue discovered in [HB 2078](#) that was signed into law this year. It permits school districts to carryover a general balance fund in excess of limits previously established by law without a general fund penalty being assessed for fiscal years beginning July 1 of 2020, 2021, 2022 and 2023. **Effective July 1, 2022.**

[SB 1037](#) by Sen. Roger Thompson, R-Okemah, and Rep. Kevin Wallace, R-Wellston, clarifies that a school's building fund may also consist of monies allocated to a school district via the federal Coronavirus Response and Relief Supplemental Appropriation Act of 2021 (CRRSA) and the federal American Rescue Plan Act of 2021 (ARP). **Effective July 1.**

[SB 1038](#) by Sen. Roger Thompson, R-Okemah, and Rep. Kevin Wallace, R-Wellston, amends the student-teaching statute to allow student teachers serving in an internship capacity to receive compensation beginning their first day from the school district in which they serve for up to one school year. However, the compensation will not be taken into consideration for teacher retirement, nor must it adhere to the state minimum salary schedule. The

bill amends language to allow students to be eligible to participate in a paid internship program, regardless of completing the minimum teacher internship requirements. **Effective July 1.**

[SB 1080](#) by Sen. Roger Thompson, R-Okemah, and House Speaker Charles McCall, R-Atoka, amends the Equal Opportunity Scholarship Act, which has been in law since 2011, to allow public schools and public school foundations to benefit from the act and increase accountability for private school donations. Donors to both the public and private side of the program would receive the same tax credit - 75% for a two-year donation commitment and 50% for one-time donation. The cap for allowable tax credits for the public side is \$25 million, as is the private side. Unused credits on the private side may be claimed on the public side and vice versa. The bill also increases accountability for participating organizations that grant private school scholarships. The law requires organizations granting private school scholarships to ensure the scholarships are awarded to low-income students at the same rate as the percentage of Oklahoma students who qualify for free- and reduced-price lunches. This bill significantly increases the annual reporting requirements for organizations raising money for private school scholarships, ensuring they are spending the required percentage of donations on scholarships for students from low-income families and providing data on whether scholarship recipients ever attended a public school. Finally, it requires public schools and public school foundations to report to the Oklahoma Tax Commission detailed information about donations received and how donations are spent. **Effective Nov. 1.**

[HB 1046](#) by Rep. Dell Kerbs, R-Shawnee, and Sen. John Michael Montgomery, R-Lawton, requires the most recent audit of a school district's financial statements be posted on the school district website for public inspection. **Effective Nov. 1.**

[SB 807](#) by Sen. Chris Kidd, R-Addington, and Rep. Rhonda Baker, R-Yukon, requires support employees to be paid for time lost when a school district is closed because of an epidemic or when a health officer orders for such a closing. **Effective July 1.**

[HB 1968](#) by Rep. Jadine Nollan, R-Sand Springs, and Sen. Brenda Stanley, R-Midwest City, makes the requirement for school districts to report the expenditures made during the year for the gifted child educational programs uniform, rather than differentiating districts by percentage spent. **Effective April 28.**

## **Retirement**

---

[SB 683](#) by Sen. Chris Kidd, R-Addington, and Rep. Mark Lepak, R-Claremore, would require a non-classified (support) school employee (regularly employed for 20 hours or more per week) to make the option to enroll in teacher retirement within 30 days of employment. Failure to make the election would mean the employee will participate. If the employee chooses to opt out, they may never opt back in, unless they become employed as a classified (certified)

employee, though the years of service as a non-classified employee would not count towards retirement. **Effective July 1.**

[SB 267](#) by Sen. Dewayne Pemberton, R-Muskogee, and Rep. Jadine Nollan, R-Sand Springs, allows certain retired members of Oklahoma Teacher Retirement System (OTRS) to return to the classroom as an active teacher in common or career tech school districts, with no earnings limitation. The three-year exemption begins July 1, 2021, and applies to retirees who have been retired and drawing retirement benefits for at least a year (since July 1, 2020) and were not employed by a school district or career tech during that time. **Effective July 1.**

[HB 2293](#) by Rep. Dustin Roberts, R-Durant, and Sen. Lonnie Paxton, R-Tuttle, relating to summer school and OTRS, provides that contributing employers are to pay two contribution rates, the first to be applied to service performed during the regular school year and the second to be applied to service performed during a summer school program. A summer school program is defined as a program offering academic enrichment for students from Pre-K through 12<sup>th</sup> grades during the summer term after the close of the school year. Members (OTRS participants) shall only be considered as providing service to a summer school program if such services are provided according to a separate summer school contract between the member and the participating employer (i.e. the school district). Summer school programs do not include services performed at a participating employer offering an extended school year or services performed by staff pursuant to a 12-month contract with the employer. The method applied to setting the second contribution rate may take into consideration whether, or to what extent, such service is likely to add to members' service credit final average salary, provided however the second rate shall not exceed one-half of the first rate. **Effective Aug. 25.**

## **Board Issues**

---

[HB 1801](#) by Rep. Sherrie Conley, R-Newcastle, and Sen. Brenda Stanley, R-Midwest City, amends Riley's Rule beginning with the 2021-22 school year. It requires school districts in coordination with emergency medical services providers that serve the area where the school is located to develop an Emergency Action Plan for each facility and athletic practices, events or activities held at school district facilities. It lists the requirements for the plan, and that it should be updated and rehearsed annually prior to the start of season practices. The plan shall be digitally transmitted to all visiting schools. **Effective Nov. 1.**

[HB 1963](#) by Rep. Jadine Nollan, R-Sand Springs, and Sen. Brenda Stanley, R-Midwest City, allows the governor to appoint a school board member to a local board if the board lacks enough seated members to have a quorum and conduct school business. The gubernatorial appointee would serve the remainder of the term and would be required to meet all the same criteria as if the board member were elected. **Effective Nov. 1.**

[SB 121](#) by Sen. Carri Hicks, R-OKC, and Rep. Carol Bush, R-Tulsa, requires each school district board of education to adopt a policy allowing school employees

who are lactating to take paid break time to maintain their milk supply. The measure allows the break time to run concurrently with any break time and requires a reasonable effort to provide a private, sanitary room for employees to express milk or breastfeed a child. **Effective July 1.**

[SB 302](#) by Sen. Bill Coleman, R-Ponca City, and Rep. Chris Kannady, R-OKC, would grant visiting teams in all regular high school athletic competitions the same rights as the home team to radio broadcast, live stream and provide telegraphic play-by-play accounts beginning in the 2021-2022 school year. In order to use these rights, the visiting team must have either an appropriate agreement between a media organization and the school's board of education or a student-run program that provides streaming for home games. **Effective July 1.**

[SB 347](#) by Sen. Lonnie Paxton, R-Tuttle, and Rep. Ryan Martinez, R-Edmond, prohibits municipalities and political subdivisions from holding an election on the second Tuesday of December 2021, the second Tuesday of January 2022 or the first Tuesday of March 2022, for the offices of United States Representative, State Senator, State Representative and County Commission districts following the reapportionment of such districts in order for the State Election Board to properly implement new precincts associated with new district boundaries. It also adds the second Tuesday of June of an odd-numbered year as a possible date for a political subdivision (i.e. school district) to hold a special election to fill a vacancy. **Effective May 5.**

[HB 1775](#) by Rep. Kevin West, R-Moore, and Sen. David Bullard, R-Durant, states that no employee of a school district, charter school or virtual charter school shall require or make part of a course the following concepts: that one race or sex is inherently superior to another race or sex; that an individual, by virtue of his or her race or sex, is inherently racist, sexist or oppressive, whether consciously or unconsciously; that an individual should be discriminated against or receive adverse treatment solely or partly because of his or her race or sex; that members of one race or sex cannot and should not attempt to treat others without respect to race or sex; that an individual's moral character is necessarily determined by his or her race or sex; that an individual, by virtue of his or her race or sex, bears responsibility for actions committed in the past by other members of the same race or sex; that any individual should feel discomfort, guilt, anguish or any other form of psychological distress on account of his or her race or sex, or the meritocracy or traits such as a hard work ethic are racist or sexist or were created by members of a particular race to oppress members of another race. Nothing is to prohibit teaching in accordance with the academic standards, and the SDE is to develop rules to implement this bill. **Effective July 1.**

[SB 54](#) by Rep. Daniel Pae, R-Lawton, and Sen. John Michael Montgomery, R-Lawton, directs the SDE, beginning in the 2022-23 school year, to designate a school campus as a Purple Star School campus if the school applies and meets certain qualifications related to availability of services for military-connected students. **Effective Nov. 1.**

[SB 658](#) by Sen. Rob Standridge, R-Norman, and Rep. Kevin West, R-Moore, prohibits school boards for school districts and technology centers, as well

as public and private higher education institutions, from implementing a mask mandate for students who have not been vaccinated against COVID-19; requiring a vaccination against COVID-19 as a condition of admittance to or attendance of the school or institution; or requiring documented proof of COVID-19 vaccination. It allows a board of education for a school district or technology center to implement a mandate to wear a mask or “any other medical device” only under the following conditions: the board must first consult with its local county or city-county health department; and the area where the board is located is under a state of emergency declared by the governor. The mandate must include its purpose, must specifically include what masks or medical device would meet the mandate’s requirements, and the board must reconsider the mandate at each regularly scheduled board meeting. The bill also requires a school district to post immunization information on its website and would restrict school boards from enacting a mask mandate unless certain criteria are met. Each school district’s website must include the following statement: “For school enrollment, a parent or guardian shall provide one of the following: current, up-to-date immunization records or a completed and signed exemption form.” **Effective July 1.**

## **Employee Professional Development, Certification, Employment Issues**

---

[HB 1967](#) by Rep. Jadine Nollan, R-Sand Springs and Sen. Dewayne Pemberton, R-Muskogee, requires a school bus driver witnessing a vehicle passing a bus while loading or offloading students to report this traffic violation to local law enforcement on or before the end of the next business day, rather than within 24 hours. **Effective Nov. 1.**

[SB 13](#) by Sen. Brenda Stanley, R-Midwest City, and Rep. Rhonda Baker, R-Yukon, states that if a teacher’s certificate is suspended by the SBE, while awaiting proceedings for revocation or other action are pending before the SBE, the local district shall place the teacher on suspension. This would not preclude the local district from initiating due process procedures. The purpose of this bill is to allow the school board to go through the proper process for potentially terminating an employee whose certificate is suspended, and to not have to automatically terminate the employee, thus risking unemployment costs. **Effective July 1.**

[HB 2749](#) by Rep. Rhonda Baker, R-Yukon, and Sen. Adam Pugh, R-Edmond, would require school districts that receive at least \$2,500 in Reading Sufficiency Act (RSA) funding to provide professional development on the science of reading for pre-K through fifth-grade teachers beginning with the 2022-2023 school year. No less than 10% of the RSA funds are required to go to the professional development. The professional development shall include training in the science of how students learn to read as well as instructional materials required for implementation. By June 30, 2022, the SDE shall approve and publish a list of professional development programs that are evidence-based and directly address the cognitive science of how students learn to read for which districts are permitted to use the funds received. **Effective Aug. 25.**

[HB 1593](#) by Rep. Melissa Provenzano, R-Tulsa, and Sen. Brenda Stanley, R-Midwest City, requires local boards of education to provide professional development for teachers in multiple areas for a first-year certified teacher and other times as follows: emphasizing the “importance of digital teaching and learning standards” at least during a teacher’s first year in the district (then at frequency set by local board); another program that emphasizes the importance of recognizing and addressing the mental health needs of students (must be done every third year); one emphasizing the importance of incorporating workplace safety training for 7th-12th grade teachers (frequency determined by local board); one requiring in-service training on alcohol and drug abuse (must be done every third year). **Effective Nov. 1.**

[SB 21](#) by Sen. Kay Floyd, D-OKC, and Rep. Marcus McEntire, R-Duncan, requires school boards to adopt a policy regarding suicide awareness and training. Beginning with the 2021-2022 school year, districts must provide staff training on evidence-based suicide awareness and prevention on a biennial (every other year) basis. Beginning with the 2022-2023 school year, the bill authorizes school boards to offer suicide awareness and prevention training to students in 7- 12<sup>th</sup> grades. The law allows local boards to enter into agreements with youth services agencies for the provision of intervention and prevention services. **Effective July 1.**

[HB 1796](#) by Rep. Nicole Miller, R-Edmond, and Sen. Adam Pugh, R-Edmond, allows the state Board of Education to exempt a teacher from taking a subject area exam for initial certification in a field which does not require an advanced degree if the candidate has an advanced degree in the subject that is substantially comparable to the content on the subject area exam. The OEQA shall provide the state Board of Education with the necessary information to determine comparability. **Effective April 28.**

[HB 2748](#) by Rep. Rhonda Baker, R-Yukon, and Sen. Brenda Stanley, R-Midwest City, creates a one-year alternative teacher certification, renewable for up to three years, for elementary and early childhood education teacher candidates. The candidates must have completed a terminal degree from an accredited institution or have at least a bachelor’s degree and two years post-degree-completion qualified work experience in a corresponding field. They must intend to earn standard certification within three years and to complete several courses, testing and mentorship requirements. Within the first year, they must satisfactorily complete six credit hours in classroom management and reading instruction, complete the required SDE-approved training on cognitive science of how students learn to read and participate in a yearlong mentorship or instructional coaching in reading and classroom management provided by the employing school district prior to the renewal of the provisional certificate for a second year. Within the second year, satisfactorily complete six credit hours in child development and math instruction and participate in an additional yearlong mentorship and/or instructional coaching in child development and math instruction prior to the renewal of the provisional certificate for a third year and successfully complete the general education subject area portions of the competency exam in the area of specialization for which certification is sought. Finally, within the third year, satisfactorily complete six additional credit hours

of professional education coursework in an educator preparation program, participate in an additional yearlong mentorship and/or instructional coaching provided by the employing school district, and successfully pass the professional knowledge portions of the competency exam in the area of specialization for which certification is sought. **Effective Nov. 1.**

[HB 2752](#) by Rep. Rhonda Baker, R-Yukon, and Sen. Brenda Stanley, R-Midwest City, requires the SDE to establish micro-credentials for teachers in the areas of science, technology, engineering and mathematics (STEM). The measure requires the SDE, in consultation with the OEQA, to convene a working group to determine how such micro-credentials will be used. A micro-credential in STEM shall be used to exempt a teacher from the corresponding subject area competency exams and will serve as corresponding professional development and may be offered in-person or virtually. **Effective July 1.**

[SB 89](#) by Sen. John Haste, R-Broken Arrow, and Rep. Rhonda Baker, R-Yukon, creates the “Health Education Act,” adding health to school core curriculum. Its purpose is to ensure students receive instruction in health; support the health and well-being of children that have been affected by traumatic experiences; improve academic outcomes for students; and improve the overall health outcomes of Oklahoma’s population. It requires health education to be taught in public schools and include physical, mental, social, emotional and intellectual health, and directs the SDE to develop a micro-credential for teachers teaching health education and professional development programs no later than the 2022-2023 school year. It directs school districts by the 2023-2024 school year to provide instruction addressing all health education subject matter standards adopted by the SBE. It allows health education to be integrated into one or more existing subjects, and requires teachers assigned to teach health education as a stand-alone course to be certified in physical and health education. The bill allows for a provisional certificate, valid for two years, to individuals assigned to teach a stand-alone health education course in order to afford the individual the opportunity to obtain certification. The bill directs the State Textbook Committee to include a review of health and physical education instructional materials as part of its textbook review and adoption cycle. The bill creates the Health Education Revolving Fund to carry out the act and directs the Healthy and Fit School Advisory Committee within schools to study and make recommendations regarding implementation of the Act. **Effective July 1.**

## **Students/ Curriculum**

---

[HB 2030](#) by Rep. Terry O’Donnell, R-Catoosa, and Sen. Adam Pugh, R-Edmond, requires public school students to pass the U.S. citizenship test in order to graduate high school, beginning with ninth graders in the 2021-2022 school year. The test shall be offered at least once a year, beginning as early as 8<sup>th</sup> grade. The student may retake the exam upon request, as often as desired, until earning a passing score of 60 out of 100 questions. School districts shall exempt students with disabilities whose IEPs state the student is to be assessed with alternate achievement standards. The bill also amends history, social studies and U.S. government curriculum standards to add the study of important historical

documents, including the U.S. Constitution, Declaration of Independence, Emancipation Proclamation, Federalist Papers and other documents with significant history and heritage of the U.S. It also states that the U.S. government standards shall include an emphasis on the structure and relationship between the national, state, county and local governments and simulations of the democratic process. **Effective Nov. 1.**

[SB 252](#) by Sen. Brenda Stanley, R-Midwest City, and Rep. Rhonda Baker, R-Yukon, requires, beginning in the 2024-2025 school year, all public schools, including charter schools, to offer:

- High school: at least one computer science course to students.
- Middle school: instruction in exploratory computer science content.
- Elementary school: instruction in the basics of computer science content and computational thinking.

Course standards will be defined by the state Board of Education, and the courses can be offered in an in-person setting or as a virtual or distance course option only when a traditional classroom setting is not feasible. The bill requires that by June 30, 2025, and every June 30 thereafter, the school district/charter school must submit a report to the SDE regarding computer science courses/content offered the previous year and for SDE to post the information on its website. **Effective Nov. 1.**

[HB 1104](#) by Rep. Mark Vancuren, R-Owasso, and Sen. John Michael Montgomery, R-Lawton, adds to the definition of “student data” a district is required to collect to include a student’s tribal affiliation and other data associated with students who have been identified as having American Indian heritage. **Effective Aug. 25.**

[SB 642](#) by Sen. Adam Pugh, R-Edmond, and Rep. Sean Roberts, R-Hominy, beginning with the 2021-2022 school year, requires each public school district and charter school provide students in 10<sup>th</sup>-12<sup>th</sup> grade an opportunity to take the Armed Services Vocational Aptitude Battery Test (ASVAB) and consult with a military recruiter. The district and charter school will not have to offer the ASVAB if they offer an alternative test that assesses a student’s aptitude for success in a career field other than one that requires post-secondary information; is free to administer; requires minimal staff training to administer; and provides the students with test results and an interpretation of those results. **Effective July 1.**

[HB 1026](#) by Rep. Rande Worthen, R-Lawton, and Sen. John Michael Montgomery, R-Lawton, allows CLEET to establish and certify additional law enforcement and criminal justice programs at Oklahoma career techs for teaching students between 16 and 19 years of age. **Effective Nov. 1.**

[SB 132](#) by Sen. David Bullard, R-Durant, and Rep. Rhonda Baker, R-Yukon, amends the Oklahoma Higher Learning Access Program (Oklahoma’s Promise) to allow students in 11th grade to sign up for the program (previously 10<sup>th</sup> grade).

It also states that students who become eligible after completing the 11<sup>th</sup> grade or after reaching the age of 17 shall be given the opportunity to participate (previously 10<sup>th</sup> grade/ 16 years old). **Effective July 1.**

[HB 1715](#) by Rep. Brian Hill, R-Mustang, and Sen. Adam Pugh, R-Edmond, repeals the requirement that any person under the age of 18 wishing to apply for a driver license or permit successfully demonstrate a satisfactory reading ability at the 8th-grade reading level. It also repeals the law that says the Department of Public Safety shall deny a license, restricted license or instruction permit for the operation of a motor vehicle to any person under 18 who does not, at the time of application, present documentation of enrollment in a public or private secondary school, including any technology center school. **Effective April 26.**

[SB 128](#) by Sen. Dave Rader, R-Tulsa, and Rep. Dick Lowe, R-Amber, creates the “Seizure-Safe Schools Act.” This act applies only to schools that have an enrolled student who has a seizure disorder. The act requires each school district, beginning Jan. 1, 2022, to have at least one employee who has training to administer or assist with self-administration of seizure medication, recognize symptoms of seizures and take steps to respond. Before seizure medication can be administered, the parent or legal guardian of the student is to provide written authorization annually to the school, provide a statement from the student’s health care provider with instructions, provide medication (sealed from pharmacy) to the school and collaborate on a seizure action plan. A seizure action plan means a written, individualized health plan designed to acknowledge and prepare for the health care needs of a student diagnosed with a seizure disorder. The bill also requires every public school district to provide an age-appropriate seizure education program to all students. It exempts from disciplinary proceedings school employees who take action in compliance with the act and provides immunity from civil liability to a school employee unless the actions rise to the level of reckless or intentional misconduct. It states that a school nurse shall not be responsible for and shall not be subject to disciplinary actions for actions taken by a volunteer. **Effective April 26.**

[HB 1103](#) by Rep. Mark Vancuren, R-Owasso, and Sen. John Haste, R-Broken Arrow, requires public schools beginning in the 2022-2023 school year, and biennially thereafter, to administer the Oklahoma Prevention Needs Assessment Survey in grades 6, 8, 10 and 12 (or an alternate survey -- if a waiver is approved). The survey is managed by the Oklahoma Department of Mental Health and Substance Abuse Services, and the department shall provide technical assistance for schools in survey administration reporting, and in the planning and development of school mental health prevention and intervention strategies informed by the survey results. The purpose of the survey is to provide direction to school sites, districts and communities to effectively improve the lives of students regarding many issues including alcohol, tobacco, other drug use, mental health, academic failure and violence. If a district chooses to use an alternative assessment, it must apply for a waiver from the Department of Mental Health. This is subject to federal funding. **Effective Nov. 1.**

[HB 1568](#) by Rep. Jeff Boatman, R-Tulsa, and Sen. John Haste, R-Broken Arrow, creates “Maria’s Law,” which requires the state Board of Education to mandate

all schools provide instruction in mental health, emphasizing the interrelation between physical and mental well-being, beginning with the 2022-2023 school year. In collaboration with the Department of Mental Health and Substance Abuse Services (ODMHSAS), the state Board of Education is required to adopt age-appropriate curriculum for students in grades K-12. Local school districts may enter into agreements with nonprofits and other community partners to provide this education to students. **Effective Nov. 1.**

[SB 619](#) by Sen. David Bullard, R-Durant, and Rep. Kevin West, R-Moore, amends the Apprenticeships, Internships and Mentorships Act of 2016, allowing sophomores 16 and older to participate in the program (current law allows juniors and seniors). It also allows the school to obtain liability insurance coverage to protect a student who participates in an apprenticeship, internship or mentorship; the school cannot pass the liability insurance costs to the student. The state Board of Education may develop rules to determine if apprenticeships, internships, and mentorships are eligible for academic credit toward meeting graduation requirements. **Effective July 1.**

[HB 1569](#) by Rep. Jacob Rosecrants, D-Norman, and Sen. Adam Pugh, R-Edmond, creates the “Oklahoma Play to Learn Act.” It allows educators to create a learning environment that facilitates child-directed experiences based upon developmentally appropriate early childhood practices and intentionally sustained, play-based learning opportunities including but not limited to, movement, creative expression, exploration, socialization, reading for pleasure, art, music and dramatic play. It requires the SBE to promulgate rules subject to legislative approval, establishing guidelines for professional development programs for early childhood educators and administrators. **Effective May 11.**

## **Public Meetings and Public Records**

---

[SB 403](#) by Sen. Brenda Stanley, R-Midwest City, and Rep. Robert Manger, R-OKC, makes it unlawful for any person, alone or in concert with others and without authorization, to willfully disturb, interfere or disrupt business or operations of any political subdivision, which includes publicly posted meetings. **Effective April 21.**

[HB 1014](#) by Rep. Cynthia Roe, R-Lindsay, and Sen. Frank Simpson, R-Springer, modifies the confidentiality of public health information of a person who has participated in a public health investigation or who may have a reportable communicable or noncommunicable disease. The bill requires this information and records maintained by the state Department of Health to be confidential while excluding information and records held by certain entities. State Department of Health records are not required to be produced pursuant to the Oklahoma Open Records Act, though certain information is required to be released in accordance with federal law. The bill removes specific identification requirements on information release orders. It also prohibits the attendance of students having or suspected of having a communicable disease in public or private schools. The responsibility of removing such student is transferred from teachers to schools. Finally, the bill updates entities granting permission to return to school. **Effective April 20.**

[HB 1876](#) by Rep. Tammy West, R-Bethany, and Sen. Brenda Stanley, R-Midwest City, exempts certain personal information of current and former public employees from mandatory disclosure under the Open Records Act. This includes home addresses, home and mobile telephone numbers, social security numbers and private email. However, a public record created using a private email address or private mobile phone wouldn't be exempt. **Effective May 3.**

[HB 1875](#) by Rep. Tammy West, R-Bethany, and Sen. Brenda Stanley, R-Midwest City, prohibits an educational agency or institution, that is not the primary custodian of student directory information of students attending the institution, from releasing or selling any or all student directory information unless disclosure is authorized by federal law. If this prohibition does not apply, the educational institution would be authorized to designate specific information to be classified as directory information for students attending the institution. **Effective May 10.**

## **Construction, Purchasing**

---

[HB 2862](#) by Rep. Kevin Wallace, R-Wellston, and Sen. Dewayne Pemberton, R-Muskogee, raises the dollar limits and thresholds for requiring public constructions contracts to be competitively bid in accordance with the Competitive Bidding Act. It raises the threshold from \$50,000 to \$100,000 for public construction contracts and maintains \$50,000 for construction management trade contracts or subcontracts. So, if your project is under \$100,000, you are no longer required to publicly bid your project. **Effective Nov. 1.**

[HB 1789](#) by Rep. Daniel Pae, R-Lawton, and Sen. Brent Howard, R-Altus, allows local government entities to create a purchasing cooperative or contract with a purchasing cooperative in order to achieve the best value or the best terms in contracts. Local governmental units, or local governmental units cooperating under the terms of any interlocal cooperative agreement authorized by state law, may create a purchasing cooperative or contract with a purchasing cooperative to provide leverage in achieving best value or the best terms in contracts. To encourage intergovernmental collaboration, any purchasing cooperative or interlocal cooperative entity may use any single legal newspaper of this state to serve as sufficient compliance for bid notice requirements of competitive bidding or solicitation of bids. If the purchasing cooperative or interlocal cooperative entity is engaging in a project exclusive to a county or group of counties of Oklahoma, and not open to all governmental units or public trusts that wish to participate statewide, the bid notice shall be published in a legal newspaper located within the county or group of counties. Any local governmental unit or public trust that enters into membership or contracts with a purchasing cooperative or interlocal cooperative entity may enter into purchases or contracts under the terms negotiated by the purchasing cooperative or interlocal cooperative entity. If the purchasing cooperative or interlocal cooperative entity complies with the requirements of this section of law, all local governmental units shall be deemed in compliance with the requirements set forth for bid notices and publication. **Effective Nov. 1.**

[SB 22](#) by Sen. Kay Floyd, D-OKC, and Rep. Tammy West, R-Bethany, modifies the powers and duties of school district boards of education, by giving the right of first refusal to purchase real or personal property to a lessee that is leasing the real or personal property from a board of education when the decision is made to dispose of the property, whether such disposal is by public sale, public bid or private sale. If the board receives a bid or offer for the real or personal property, the board is to provide notice to the lessee leasing the property, and include the identity of the prospective purchaser, the terms and conditions of the proposed sale and the purchase price. It gives the lessee 30 days after receipt of notice to inform the board whether it elects to purchase the property on the same terms and conditions provided in the notice. **Effective Nov. 1.**

## Miscellaneous

---

[HB 1773](#) by Sen. Jessica Garvin, R-Duncan and Rep. Sherrie Conley, R-Newcastle, requires early childhood, elementary, secondary and special education teacher candidates to study the multi-tiered systems of support (MTSS) and its overarching philosophy, framework and components. MTSS is designed to address the core academic and nonacademic needs of students and identify at-risk students. The bill outlines what the training shall include but not be limited to. **Effective Nov. 1.**

[HB 2691](#) Rep. Toni Hasenbeck, R-Elgin, and Sen. Micheal Bergstrom, R-Adair, requires the Commission for Educational Quality and Accountability (OEQA) to issue a report by Oct. 31, 2021, detailing factors in the public education system that contribute to improvements in high school graduation rates and college and career assessment scores; reduced remediation rates; timely college graduation rates; career readiness; and the ability for new graduates to find in-state employment. If OEQA finds there is insufficient information to fulfill these requirements, the report shall contain recommendations for addressing information gaps between the SDE, Career Tech and the State Regents. The report shall be submitted to the speaker, pro tempore and governor. **Effective July 1.**

[HB 1018](#) by Rep. Danny Sterling, R-Tecumseh, and Sen. Marty Quinn, R-Claremore, removes the requirement that the SDE compile and publish the school law book. **Effective Nov. 1.**

[HB 2223](#) by Rep. Randy Randleman, R-Eufaula, and Sen. Dewayne Pemberton, R-Muskogee, requires the SDE to maintain the dyslexia handbook created by the Dyslexia and Education Task Force. The SDE is required to review and revise the handbook at least every three years in consultation with stakeholders and the task force. **Effective Nov. 1.**

[HB 2750](#) by Rep. Rhonda Baker, R-Yukon, and Sen. Adam Pugh, R-Edmond, requires colleges and universities within the Oklahoma State System of Higher Education to post their policies beginning with the 2021-2022 school year on advance placement course credit to their websites. The bill suggested that higher ed not require more than a 3 on an AP exam for course credit but would allow higher than 3 for granting additional course credit. **Effective July 1.**

[SB 292](#) by Sen. John Haste, R-Broken Arrow, and Rep. Jadine Nollan, R-Sand Springs, creates a task force to study and make recommendations regarding the current and future concurrent enrollment needs of the state and pathways for awarding degrees and certificates through concurrent enrollment. The task force is created until Nov. 30, 2022. **Effective July 1.**

[HB 1882](#) by Rep. Marilyn Stark, R-Bethany, and Sen. Dave Rader, R-Tulsa, creates the Out-of-Schooltime Task Force. The task force is directed to identify, evaluate and recommend a set of best practices for children, youth and families which will improve and increase the number of quality, affordable out-of-school programs in the state. The bill outlines the meeting requirements and membership of the task force. The task force shall issue a report of its findings to the president pro tempore of the senate, speaker of the house, and governor no later than Dec. 1, 2022. **Effective Nov. 1.**

[SB 1033](#) by Sen. James Leewright, R-Bristow, and Rep. Scott Fetgatter, R-Okmulgee, provides for medical marijuana establishments to maintain a building within 1,000 feet of a new school building provided the license for such an establishment was granted prior to the establishment of the building or there was an error of measurement as it relates to the distance of the dispensary from the school. The measurement shall be based on the distance in a straight line from the school door nearest the front door of the retail marijuana establishment to the front door of the retail marijuana establishment. It also clarifies that any original medical marijuana business license issued on or after June 26, 2018, by the Oklahoma Medical Marijuana Authority, for a medical marijuana commercial grower, a medical marijuana processor, or a medical marijuana dispensary shall be deemed to have been grandfathered into the location on the date the original license was first issued and provides for the grandfathered status to be transferred if a change in ownership occurs. The bill authorizes municipalities to object to the continued licensure of the grandfathered medical marijuana dispensary when it is operating contrary to the required setback distance from a public or private school. Upon the municipal government providing the required documentation outlined in the measure, the authority shall not renew or transfer the medical marijuana dispensary license and shall cause the license to be revoked. **Effective May 28.**





**The 2021 Legislative Review is not all inclusive of every new law effecting education and is meant as a reference guide only. Legal information provided by OSSBA is non-binding and is not intended to replace the advice of the school district's retained legal counsel.**



**FILED**

May 7, 2021

OKLAHOMA SECRETARY OF  
STATE



J. Kevin Stitt  
Office of the Governor  
State of Oklahoma

**EXECUTIVE DEPARTMENT  
EXECUTIVE ORDER 2021-12**

---

Today, I signed into law House Bill 1775. House Bill 1775 helps us move to a future where all four million Oklahomans are treated as valued children of God. This legislation prohibits the teaching of concepts repugnant to the vast majority of Oklahomans. Among these are notions that “one race or sex is inherently superior to another race or sex” and “an individual, by virtue of his or her race or sex, is inherently racist ...”

All of our children need to learn about the promises and ideals that make our state and nation great and also learn where we have fallen short and where we can strive to better achieve our highest moral purposes. In some discussions of this matter, however, a critical part of the bill has been overlooked. Section 1, subsection B ensures the “provisions of this [bill] shall not prohibit the teaching of concepts that align to the Oklahoma Academic Standards.” These standards include important topics in America’s fraught history with race from the *Dred Scott* decision and the Civil War to segregation and Oklahoma’s own history, including the Trail of Tears, the Tulsa Race Massacre of 1921, and the courage of Clara Luper. These topics should and will be taught in Oklahoma schools so that we may reckon with our history.

Unfortunately, a growing movement in our country seeks to divide people by race and other markers of identity. Some go so far as to say “(t)he only remedy to past discrimination is present discrimination. The only remedy to present discrimination is future discrimination.” I believe we can do better than that. As long as I am Governor, we will strive to live up to the words of Dr. Martin Luther King Jr. and build an Oklahoma where all people are “not ... judged by the color of their skin but by the content of their character.”

To ensure clarity in the implementation of House Bill 1775 and to provide guidance for the State Regents for Higher Education and the State Board of Education, I declare that it is my intent that no topic of our history or present inequalities are to be hidden from view. Rather, it is my intent that we teach about Oklahoma’s diversity in light of its fundamental unity. We must come together as one people and refuse to be divided by those who would profit from fringe theories.

THEREFORE, I HEREBY CALL ON the Oklahoma State Board of Education to implement this Bill consistent with the existing Oklahoma Academic Standards.

51138

This Executive Order shall be distributed to the State Regents for Higher Education and members of the State Board of Education, who shall cause the provisions of this Order to be implemented.

IN WITNESS WHEREOF, I have set my hand and caused the Great Seal of the State of Oklahoma to be affixed at Oklahoma City, Oklahoma, this 7<sup>th</sup> day of May, 2021.

**BY THE GOVERNOR OF THE STATE OF OKLAHOMA**

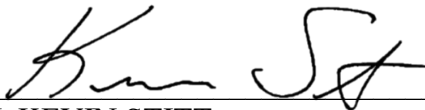
  
\_\_\_\_\_  
J. KEVIN STITT

ATTEST:



  
\_\_\_\_\_  
BRIAN BINGMAN, SECRETARY OF STATE

Board Minutes  
Oakdale Public School Board of Education Regular Meeting  
Tuesday, June 8, 2021 6:00 PM  
Fine Arts Building

---

President – Erin Hulsey

---

Vice President – Todd Corbin

---

Clerk – Jerome Loughridge

---

Minutes Clerk - Marlene Martinez-Dunn

**1. Routine Items:**

- **Call to Order**
- **Roll Call**
- **Establishment of a Quorum**
- **Possible consideration and vote to approve Agenda**

Attendance Taken at 6:00 PM.

Mr. Todd Corbin: Present

Erin Hulsey: Present

Jerome Loughridge: Present

Present: 3.

**2. Pledge of Allegiance, Moment of Silence, & Inspirational Thought**

**3. Staff Reports, Presentations, and/or Recognitions**

- **Superintendent's Update: Dr. Joe Pierce**
- **Information Presentation: Safe Return & Continuity of Service Plan 2021-22**
- **Elementary School Principal: Jenna Foster**
- **Middle School Principal: Jill Willhoite**
- **Independent Committee &/or Sanctioned Organization Reports**

**4. Public Comment:** All meetings of the Board of Directors shall be open to the public and any regular meeting shall include an opportunity for the public to address the Board. Public Comments are limited to three (3) minutes and must be related to an agenda item or topic. Members of the public wishing to address the board must sign up before the meeting. Where several people wish to address the same subject, a spokesperson must be selected. The Board President may interrupt and terminate any comments that are not in accordance with any of these criteria or in keeping with Board Policy BED . Board members may not respond to speakers' comments. See attachment.

**Shelly Lott via Emily Dinwiddie addressed the board in regard to the middle school reading lists.**

**5. Consent Agenda:** The following items concern reports and items of a routine nature normally approved at Board meetings. They will be considered and voted on together as a group with one vote; provided that any Board member may ask that one or more items be considered and voted on separately. The Consent Agenda includes discussion, consideration, and possible action upon the following items:

The board approved the consent agenda. This motion, made by Jerome Loughridge and seconded by Mr. Todd Corbin, passed.

Mr. Todd Corbin: Yea

Erin Hulsey: Yea

Jerome Loughridge: Yea

Yea: 3, Nay: 0

1. Approve minutes of the May 11, 2021 regular board meeting.
2. Accept Treasurer's Report including: Financial statements, fund balances, expenditures, revenue, warrants, bank summary, bond reports, and investments) for the month ending May 28, 2021.
3. General Fund Payments # 2943-#2967
4. Child Nutrition Payments are included with General Fund Payments
5. Building Fund Payments #479-#495
6. Activity Fund Payments #251-#273
7. Bond 34 Payments #53-#54
8. BOND 35 NO PAYMENTS
9. Approval of the following contracts and agreements:

1. Hickman Law Group renewal
2. Gabbart Communications renewal
3. Teel Oswald, PhD, School Psychologist renewal
4. Moore Therapy Services, Inc.
5. Shelly Ryland, SLP renewal
6. Go Guardian renewal
7. PowerSchool (McRel/TalentEd) renewals
8. PowerSchool/School Insight (TeacherEase) renewal
9. Oklahoma School Insurance Group (OSIG) renewal
10. Oklahoma School Assurance Group (OSAG) renewal
11. Community Action Agency agreement
12. OPSRC membership renewal for 21-22
13. OSSBA membership/services renewal for 21-22
14. Putnam & Company, CPAs, Auditor renewal
15. Steve Huff/EAS Consulting renewal

The board approved the contracts and agreements for the 2021-2022 school year. This motion, made by Jerome Loughridge and seconded by Mr. Todd Corbin, passed.

Mr. Todd Corbin: Yea

Erin Hulsey: Yea

Jerome Loughridge: Yea

Yea: 3, Nay: 0

**6. Executive Session:**

**Proposed executive session to discuss the employment of certified and support personnel as listed in**

**Exhibit A: Personnel Report and for the purpose of discussing the superintendent's contract. 25 O.S. Section 307(B)(1)**

1. Vote to convene or not to convene into executive session

The board voted to convene into executive session at 6:58 p.m. This motion, made by Jerome Loughridge and seconded by Mr. Todd Corbin, passed.

Mr. Todd Corbin: Yea

Erin Hulseley: Yea

Jerome Loughridge: Yea

Yea: 3, Nay: 0

2. The board acknowledged return to open session at 7:39 p.m.

3. Executive Session Minutes and Compliance Statement was read by Erin Hulseley, President of the board.  
**No Action was taken in Executive Session.**

**7. Business (Action) Items: The following items will be considered, discussed, and possible action taken on each one separately.**

1. Consideration, discussion, and possible action on Safe Return & Continuity of Services Plan for 2021-22

The board approved the Safe Return & Continuity of Services Plan for 2021-22 as recommended by the superintendent. This motion, made by Mr. Todd Corbin and seconded by Jerome Loughridge, passed.

Mr. Todd Corbin: Yea

Erin Hulseley: Yea

Jerome Loughridge: Yea

Yea: 3, Nay: 0

2. Consideration, discussion, and possible action on Superintendent's contract for 2021-22.

The board approved the superintendents contract for the 2021-2022 school year. This motion, made by Mr. Todd Corbin and seconded by Jerome Loughridge, passed.

Mr. Todd Corbin: Yea

Erin Hulseley: Yea

Jerome Loughridge: Yea

Yea: 3, Nay: 0

3. Consideration, discussion, and possible action on certified & support personnel recommendations as listed in Exhibit A: Personnel Report.

The board approved the hiring of the certified & support personnel as recommended by the superintendent and listed on Exhibit A: Personnel Report. This motion, made by Mr. Todd Corbin and seconded by Jerome Loughridge, passed.

Mr. Todd Corbin: Yea

Erin Hulseley: Yea

Jerome Loughridge: Yea

Yea: 3, Nay: 0

**8. New Business: Any matter not known about or which could not have been reasonably foreseen prior to the time of posting.**

**9. Adjourn: Possible consideration, discussion, and vote to adjourn.**

The board voted to adjourn meeting at 7:41 p.m. This motion, made by Mr. Todd Corbin and seconded by Jerome Loughridge, passed.

Mr. Todd Corbin: Yea

Erin Hulseley: Yea

Jerome Loughridge: Yea

Yea: 3, Nay: 0



**Oakdale School**  
**55-C029**

**FY21 Financial Report**  
**June 30, 2021**

**General Fund Expenditures  
as of June 30, 2021**

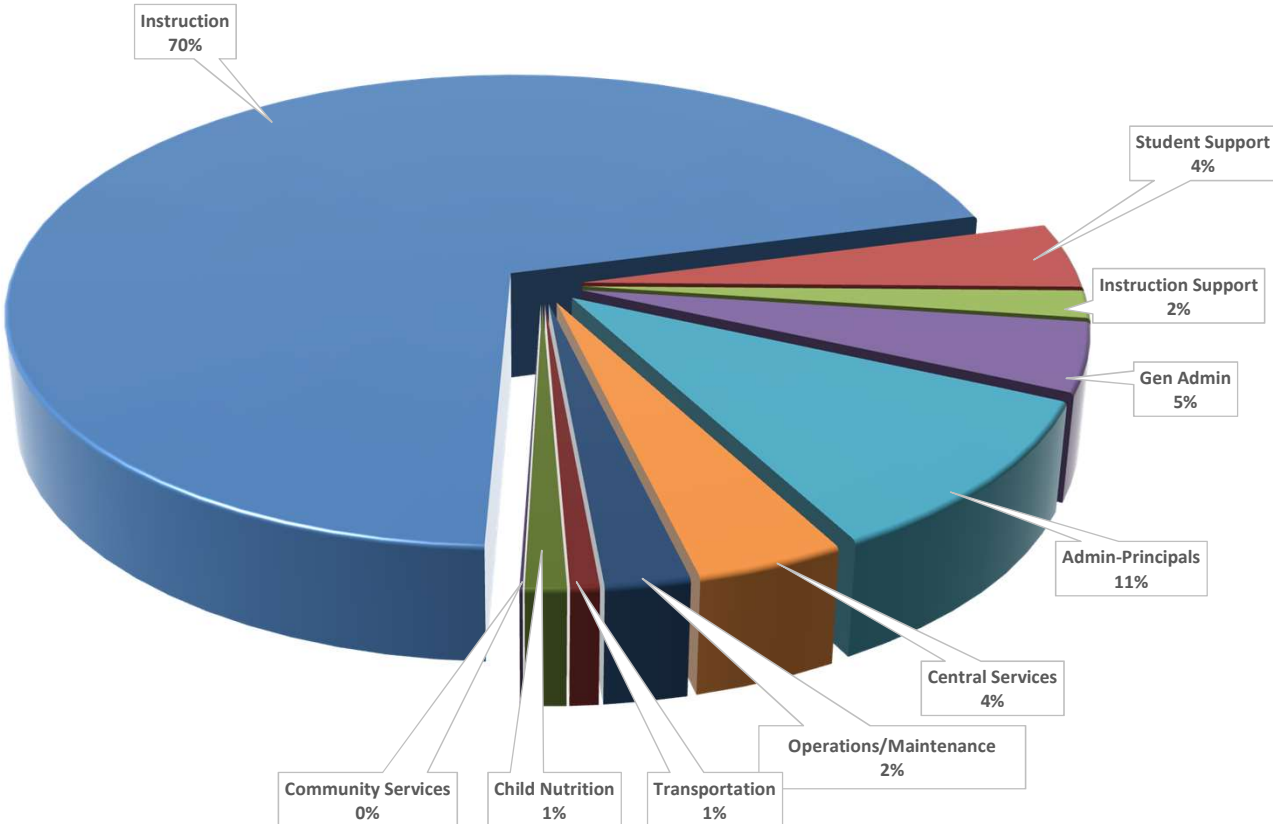

**Oakdale Public School  
Cash Balances - Appropriated Funds  
June 30, 2021**

	Balance 6/30/2021	Less: O/S Warrants 6/30/2021	Cash Balances 6/30/2021	Comparison 6/30/2020	Comparison 6/30/2021
<b>General Fund</b>					
2020-21 FY	1,122,966.54	96,724.86	1,026,241.68		
2019-20 FY	2,803.93	2,803.93	0.00		
<b>Total</b>	<u>1,125,770.47</u>	<u>99,528.79</u>	<u>1,026,241.68</u>	<u>1,176,669.24</u>	<u>1,355,493.35</u>
<b>Building Fund</b>					
2020-21 FY	139,672.49	3,765.08	135,907.41		
2019-20 FY	0.00	0.00	0.00		
<b>Total</b>	<u>139,672.49</u>	<u>3,765.08</u>	<u>135,907.41</u>	<u>185,551.91</u>	<u>145,408.41</u>
<b>Building Bond Funds</b>					
BBF (Fund 34)	71,819.86	(0.00)	71,819.86	-	-
BBF (Fund 35)	90,493.80	0.00	90,493.80	-	-
BBF (Fund 36)	4,500,000.00	0.00	4,500,000.00		
<b>Total</b>	<u>4,662,313.66</u>	<u>(0.00)</u>	<u>4,662,313.66</u>	<u>504,544.09</u>	<u>3,230,930.74</u>
<b>Sinking Fund</b>	<u>1,191,477.18</u>	<u>0.00</u>	<u>1,191,477.18</u>	<u>2,511,828.01</u>	<u>2,702,238.73</u>
<b>Total Cash Balances</b>	<u>7,119,233.80</u>	<u>103,293.87</u>	<u>7,015,939.93</u>	<u>4,378,593.25</u>	<u>7,434,071.23</u>

<b>FY21 Non-Recurring (One Time) Funds</b>		
Program	Claimed	Remaining
Project 615	1,512.74	\$ -
Project 617	1,682.02	\$ 817.98
Project 627	33,804.64	\$ -
Project 721	8,444.12	\$ -
Project 788	7,858.40	\$ 7,926.89
Project 789	29,033.00	\$ 7,943.00
Project 793	61,663.98	\$ -
Project 794	173,432.67	\$ 141,051.80



**Oakdale Public School  
General Fund Expenditures  
June 30, 2021**

	FY19 Expenditures		FY20 Expenditures		FY21 Expenditures	
	Payroll	Non-Payroll	Payroll	Non-Payroll	Payroll	Non-Payroll
July	74,679.73	52,205.09	67,711.84	28,743.40	63,359.78	64,614.63
August	178,172.55	80,862.57	203,987.56	28,694.57	228,498.51	88,565.10
September	373,625.32	22,470.80	383,903.33	25,483.55	400,876.84	40,258.26
October	370,468.67	67,275.37	385,767.35	31,172.79	413,857.93	46,631.57
November	372,992.56	30,423.88	384,402.08	74,003.92	433,423.02	52,272.55
December	362,449.37	27,851.88	434,222.85	29,883.38	408,313.10	28,914.69
January	361,243.27	15,996.44	385,115.27	30,328.66	402,304.32	19,955.53
February	373,854.82	38,817.38	385,488.81	30,222.76	414,846.55	48,212.45
March	388,987.79	17,226.09	412,295.02	36,019.84	404,371.32	31,110.82
April	380,337.90	13,076.07	406,668.45	14,157.63	420,678.77	42,008.18
May	1,110,612.81	34,387.69	1,247,218.61	11,703.68	454,645.16	51,689.83
June	270,778.53	42,689.97	48,695.50	32,678.26	918,342.86	33,307.39
<b>TOTALS</b>	<b>4,618,203.32</b>	<b>443,283.23</b>	<b>4,745,476.67</b>	<b>373,092.44</b>	<b>4,963,518.16</b>	<b>547,541.00</b>

**5,061,486.55**

**5,118,569.11**

**5,511,059.16**

**YTD Comparison**

	FY19 Expenditures		FY20 Expenditures		FY21 Expenditures	
	Payroll	Non-Payroll	Payroll	Non-Payroll	Payroll	Non-Payroll
July	74,679.73	52,205.09	67,711.84	28,743.40	63,359.78	64,614.63
August	178,172.55	80,862.57	203,987.56	28,694.57	228,498.51	88,565.10
September	373,625.32	22,470.80	383,903.33	25,483.55	400,876.84	40,258.26
October	370,468.67	67,275.37	385,767.35	31,172.79	413,857.93	46,631.57
November	372,992.56	30,423.88	384,402.08	74,003.92	433,423.02	52,272.55
December	362,449.37	27,851.88	434,222.85	29,883.38	408,313.10	28,914.69
January	361,243.27	15,996.44	385,115.27	30,328.66	402,304.32	19,955.53
February	373,854.82	38,817.38	385,488.81	30,222.76	414,846.55	48,212.45
March	388,987.79	17,226.09	412,295.02	36,019.84	404,371.32	31,110.82
April	380,337.90	13,076.07	406,668.45	14,157.63	420,678.77	42,008.18
May	1,110,612.81	34,387.69	1,247,218.61	11,703.68	454,645.16	51,689.83
June	270,778.53	42,689.97	48,695.50	32,678.26	918,342.86	33,307.39
<b>TOTALS</b>	<b>4,618,203.32</b>	<b>443,283.23</b>	<b>4,745,476.67</b>	<b>373,092.44</b>	<b>4,963,518.16</b>	<b>547,541.00</b>

**5,061,486.55**

**5,118,569.11**

**5,511,059.16**

**Oakdale Public School  
General Fund Expenditures  
June 30, 2021**

<b>Personnel Expenses</b>		<b>2020-21</b>	<b>JUNE</b>	<b>2020-21</b>	<b>% of YTD</b>
<b>OBJECT</b>	<b>DESCRIPTION</b>	<b>BUDGET</b>	<b>2021</b>	<b>YEAR-TO-DATE</b>	<b>TO BUDGET</b>
100-299	Personnel	4,991,392.16	918,342.86	4,963,518.16	99.44%
	<b>Total Personnel</b>	<b>4,991,392.16</b>	<b>918,342.86</b>	<b>4,963,518.16</b>	<b>99.44%</b>
<b>Non-Personnel Expenses</b>					
310	Administrative Services	40,939.00	-	35,939.00	87.8%
320	Professional Education Services	46,910.00	3,960.00	46,250.00	98.6%
321	Instructional Program Improvement	249.00	-	249.00	100.0%
331	Accounting & Audit Services	5,823.40	-	5,823.40	100.0%
336	Medical Services	766.00	5,611.70	766.00	100.0%
337	Othe Professional Services	6,825.00	100.00	6,825.00	100.0%
340	Technical Services	320.00	-	-	0.0%
344	Game Security Services	22,655.00	600.00	22,655.00	100.0%
346	Technology Services	6,505.00	-	5,505.00	84.6%
358	Legal Services	2,606.00	1,350.00	2,531.00	97.1%
359	Employee Training	16,933.50	674.00	13,608.50	80.4%
420	Cleaning Services	1,502.50	-	-	0.0%
430	Repairs and Maintenance	308.75	-	-	0.0%
431	Non-Tech Services	500.00	-	-	0.0%
432	Tech Svcs Computer	308.75	-	308.75	100.0%
436	Office Machine Svcs	510.00	-	510.00	100.0%
440	Rentals	630.00	-	-	0.0%
522	Liability Insurance	8,012.00	-	8,012.00	100.0%
524	Vehicle Insurance	6,676.00	-	6,676.00	100.0%
525	Surety Bonds	1,532.50	-	1,502.50	98.0%
530	Communication Services	40,272.69	8.12	34,224.43	85.0%
540	Advertising	761.22	-	761.22	100.0%
550	Printing and Binding	13,868.09	-	13,868.09	100.0%
611	Copy Supplies	5,885.70	-	5,487.75	93.2%
612	Automotive & Bus Supplies	6,905.11	1,418.54	5,444.84	78.9%
614	Testing Supplies	9,850.15	585.02	8,444.25	85.7%
615	Audiovisual Supplies	510.00	-	510.00	100.0%
616	First Aid	320.67	-	320.67	100.0%
617	Kitchen Supplies	14,415.00	1,083.41	14,260.60	98.9%
618	Maintenance Supplies	12,613.04	-	2,103.32	16.7%
619	Classroom/Office Supplies	36,697.20	1,676.43	25,315.54	69.0%
625	Gasoline	13,000.00	1,796.94	8,642.76	66.5%
630	Food and Milk	93,411.06	6,382.19	88,452.87	94.7%
639	Other Food Costs	6,642.25	454.02	5,367.30	80.8%
641	Books	9,383.14	1,626.40	1,626.40	17.3%
643	Textbooks	39,388.49	-	39,388.49	100.0%
646	Binding	273.95	-	273.95	100.0%
652	Audiovisual	2,819.34	-	2,819.34	100.0%
653	Technology Related Supplies	99,354.12	5,976.57	98,887.87	99.5%
810	Dues and Fees	17,409.31	4.05	8,702.01	50.0%
833	Interest on Non-Payable Warrants	2,285.55	-	-	0.0%
850	Game Contracts & Guarantees	725.00	-	725.00	100.0%
860	Staff Registration & Tuition	40.00	-	40.00	100.0%
930	Reimbursement	1,103.00	-	1,103.00	100.0%
	<b>Total Non-Personnel</b>	<b>598,446.48</b>	<b>33,307.39</b>	<b>547,541.00</b>	<b>91.5%</b>
<b>TOTALS</b>		<b>5,589,838.64</b>	<b>951,650.25</b>	<b>5,511,059.16</b>	<b>98.6%</b>

**Oakdale Public School  
Summary of Monthly Revenue - By Fund  
2020-21 FY**

<b>Month</b>	<b>Total</b>	<b>General Fund</b>	<b>Building Fund</b>	<b>BBF (Fund 34)</b>	<b>BBF (Fund 35)</b>	<b>BBF (Fund 36)</b>	<b>Sinking Fund</b>
<b>7-2020</b>	18,374.87	18,374.87					
<b>8</b>	211,607.74	157,946.86	8,823.55				44,837.33
<b>9</b>	86,764.25	73,169.98	2,268.51				11,325.76
<b>10</b>	84,002.41	78,116.63	960.54				4,925.24
<b>11</b>	125,091.20	116,147.93	1,452.26				7,491.01
<b>12</b>	1,394,130.57	939,065.50	115,934.75				339,130.32
<b>1-2021</b>	3,814,332.74	2,512,804.50	331,107.89				970,420.35
<b>2</b>	227,453.34	182,352.04	10,922.24				34,179.06
<b>3</b>	877,376.03	610,747.17	67,985.15				198,643.71
<b>4</b>	488,930.09	346,547.08	36,341.31				106,041.70
<b>5</b>	260,182.49	139,216.43	7,649.47			90,000.00	23,316.59
<b>6</b>	4,546,837.41	128,135.51	1,836.41	176.76		4,410,000.00	6,688.73
<b>Total</b>	<u>12,135,083.14</u>	<u>5,302,624.50</u>	<u>585,282.08</u>	<u>176.76</u>	<u>0.00</u>	<u>4,500,000.00</u>	<u>1,746,999.80</u>

**Oakdale Public School  
Warrants Issued By Month - By Fund  
2020-21 FY**

Month	Total	<u>General Fund</u>		<u>Building Fund</u>		(Fund 34)	(Fund 35)	Sinking
		2020-21 FY	2019-20 FY	2020-21 FY	2019-20 FY	BBF	BBF	Fund
<b>7-2020</b>	1,753,734.45	127,974.41		110,062.43		35,775.11		1,479,922.50
<b>8</b>	357,674.45	317,063.61		39,921.13		689.71		
<b>9</b>	566,256.00	441,135.10		42,545.22		82,575.68		
<b>10</b>	973,087.44	460,489.50		94,295.84		106,364.60		311,937.50
<b>11</b>	588,958.41	485,695.57		49,899.14		6,848.70		46,515.00
<b>12</b>	473,618.80	437,227.79		30,150.25		6,240.76		
<b>1-2021</b>	455,165.16	422,259.85		24,873.81		8,031.50		
<b>2</b>	511,141.88	463,059.00		31,144.79		16,938.09		
<b>3</b>	496,049.92	435,482.14		53,161.28		7,406.50		
<b>4</b>	522,840.59	462,686.95		42,453.64		17,700.00		
<b>5</b>	1,802,196.45	506,334.99		35,362.85		13,998.61		1,246,500.00
<b>6</b>	991,266.15	951,650.25		36,654.42		2,961.48		
<b>Totals</b>	<b>9,491,989.70</b>	<b>5,511,059.16</b>	<b>0.00</b>	<b>590,524.80</b>	<b>0.00</b>	<b>305,530.74</b>	<b>0.00</b>	<b>3,084,875.00</b>

**Oakdale Public School  
Warrants Paid By Month - By Fund  
2020-21 FY**

Month	Total	General Fund		Building Fund		(Fund 34)	(Fund 35)	Sinking
		2020-21 FY	2019-20 FY	2020-21 FY	2019-20 FY	BBF	BBF	Fund
<b>7-2020</b>	1,889,407.08	117,870.43	97,964.29	109,462.43	12,770.82	71,416.61		1,479,922.50
<b>8</b>	339,538.58	292,944.34	7,721.96	37,617.57	565.00	689.71		
<b>9</b>	563,670.42	471,003.64	23,550.80	38,564.85		30,551.13		
<b>10</b>	970,493.35	462,240.74	210.09	95,414.42		100,690.60		311,937.50
<b>11</b>	643,325.94	478,467.05		53,796.64		64,547.25		46,515.00
<b>12</b>	427,927.50	395,365.79		26,320.95		6,240.76		
<b>1-2021</b>	509,753.53	472,706.42		29,015.61		8,031.50		
<b>2</b>	375,607.30	341,551.75		26,489.46		7,566.09		
<b>3</b>	569,534.52	500,232.24		52,523.78		16,778.50		
<b>4</b>	577,219.55	513,760.81		45,758.74		17,700.00		
<b>5</b>	1,738,129.91	451,297.22		32,695.25		7,637.44		1,246,500.00
<b>6</b>	965,316.54	916,893.87		39,100.02		9,322.65		
<b>Total</b>	<b>9,569,924.22</b>	<b>5,414,334.30</b>	<b>129,447.14</b>	<b>586,759.72</b>	<b>13,335.82</b>	<b>341,172.24</b>	<b>0.00</b>	<b>3,084,875.00</b>

**Oakdale Public School  
Warrant Accounts - By Funds  
2020-21 FY**

<b><u>2020-21 FY</u></b>	<b>Total</b>	<b>General</b>	<b>Building</b>	<b>BBF (34)</b>	<b>BBF (35)</b>	<b>Sinking (41)</b>
<b>O/S @ 7-01-20</b>	0.00	0.00	0.00	0.00	0.00	0.00
Issued to Date	9,491,989.70	5,511,059.16	590,524.80	305,530.74	0.00	3,084,875.00
Less: Paid to Date	9,391,499.76	5,414,334.30	586,759.72	305,530.74	0.00	3,084,875.00
<b>O/S @ 04/30/2021</b>	<b>100,489.94</b>	<b>96,724.86</b>	<b>3,765.08</b>	<b>(0.00)</b>	<b>0.00</b>	<b>0.00</b>

<b><u>2019-20 FY</u></b>	<b>Total</b>	<b>General</b>	<b>Building</b>	<b>BBF (34)</b>	<b>BBF (35)</b>	<b>Sinking (41)</b>
<b>O/S @ 7-01-20</b>	181,228.39	132,251.07	13,335.82	35,641.50	0.00	0.00
Issued to Date	0.00	0.00	0.00	0.00	0.00	0.00
Less: Paid to Date	178,424.46	129,447.14	13,335.82	35,641.50	0.00	0.00
<b>O/S @ 04/30/2021</b>	<b>2,803.93</b>	<b>2,803.93</b>	<b>0.00</b>	<b>0.00</b>	<b>0.00</b>	<b>0.00</b>

<b><u>All Years</u></b>	<b>Total</b>	<b>General</b>	<b>Building</b>	<b>BBF (34)</b>	<b>BBF (35)</b>	<b>Sinking (41)</b>
<b>O/S @ 7-01-20</b>	181,228.39	132,251.07	13,335.82	35,641.50	0.00	0.00
Issued to Date	9,491,989.70	5,511,059.16	590,524.80	305,530.74	0.00	3,084,875.00
Less: Paid to Date	9,569,924.22	5,543,781.44	600,095.54	341,172.24	0.00	3,084,875.00
<b>O/S @ 04/30/2021</b>	<b>103,293.87</b>	<b>99,528.79</b>	<b>3,765.08</b>	<b>(0.00)</b>	<b>0.00</b>	<b>0.00</b>

**Oakdale Public Schools  
Bank Summary  
General Fund  
2020-21 FY**

<b>Month</b>	<b>Beginning Balance</b>	<b>Deposits</b>	<b>Transfers In</b>	<b>Transfers Out</b>	<b>Disbursements</b>	<b>Ending Balance</b>
<b>7-2020</b>	3,076,133.76	18,374.87		GW 120.51 SC 35.00 225.00 BC	409,484.58	2,685,093.54
<b>8</b>	2,685,093.54	211,607.74		GW 118.78 SC 35.00	339,538.58	2,557,008.92
<b>9</b>	2,557,008.92	86,764.25		GW 312.23 SC 35.00 50.00 AF	563,670.42	2,079,805.52
<b>10</b>	2,079,805.52	84,002.41		GW 130.59 SC 35.00 AF 50.00	970,493.35	1,193,098.99
<b>11</b>	1,193,098.99	125,091.20		GW 90.25 SC 35.00	643,325.94	674,739.00
<b>12</b>	674,739.00	1,394,130.57		GW 89.51 SC 35.00 BE 0.01 FY19 3,483.02	427,927.50	1,637,334.53
<b>1-2021</b>	1,637,334.53	3,814,332.74		GW 81.65 SC 35.00 BE 279.98	509,753.53	4,941,517.11
<b>2</b>	4,941,517.11	227,453.34		GW 117.48 SC 35.00 BE 575.00 3,483.02 BC 0.01 BC 279.98 BC	375,607.30	4,796,398.68
<b>3</b>	4,796,398.68	877,376.03		GW 82.98 SC 35.00 BE 95.15 575.00 BC	569,534.52	5,104,602.06
<b>4</b>	5,104,602.06	488,930.09		GW 80.40 SC 35.00 95.15 BC	577,219.55	5,016,292.35
<b>5</b>	5,016,292.35	260,182.49		GW 81.60 SC 35.00 BE 400.00	1,738,129.91	3,537,828.33
<b>6</b>	3,537,828.33	4,546,837.41		GW 80.40 SC 35.00	965,316.54	7,119,233.80
<b>Total</b>	<u>3,076,133.76</u>	<u>12,135,083.14</u>	<u>4,708.16</u>	<u>6,689.54</u>	<u>8,090,001.72</u>	<u>7,119,233.80</u>

RC = Returned checks

SC = Bank service charges-ACH

GW = Gateway and Credit Card Processing

HL = Heartland Processing

BE = Bank Error

FY19 = FY19 BF34 E-stopped Warrant # 19-34-57 Cleared 12/1/2020

## BOND PRINCIPAL AND INTEREST SCHEDULE 6/30/2021

### BUILDING BOND, SERIES B JULY 1, 2015 - \$4,520,000.00

Date	Principal	Interest	Total	Date Paid	Notes
7/1/2015	\$ -	\$ -	\$ -		
1/1/2016	\$ -	\$ -	\$ -		
7/1/2016	\$ -	\$ -	\$ -		
1/1/2017	\$ -	\$ -	\$ -		
7/1/2017	\$ 110,000.00	\$ 107,600.00	\$ 217,600.00	7/3/2017	
1/1/2018	\$ -	\$ 26,460.00	\$ 26,460.00	12/22/2017	
7/1/2018	\$ 1,470,000.00	\$ 26,460.00	\$ 1,496,460.00	7/1/2018	
1/1/2019	\$ -	\$ 18,742.50	\$ 18,742.50	12/28/2018	
7/1/2019	\$ 1,470,000.00	\$ 18,742.50	\$ 1,488,742.50	7/1/2019	
1/1/2020	\$ -	\$ 9,922.50	\$ 9,922.50	12/23/2019	
7/1/2020	\$ 1,470,000.00	\$ 9,922.50	\$ 1,479,922.50	7/1/2020	BOND RETIRED

### BUILDING BONDS of 2015 NOVEMBER 1, 2015 - \$1,100,000.00

Date	Principal	Interest	Total	Date Paid	Notes
11/1/2015	\$ -	\$ -	\$ -		
5/1/2016	\$ -	\$ -	\$ -		
11/1/2016	\$ -	\$ -	\$ -		
5/1/2017	\$ -	\$ 18,825.00	\$ 18,825.00	4/24/2017	
11/1/2017	\$ 170,000.00	\$ 6,275.00	\$ 176,275.00	10/26/2017	
5/1/2018	\$ -	\$ 5,425.00	\$ 5,425.00	4/25/2018	
11/1/2018	\$ 310,000.00	\$ 5,425.00	\$ 315,425.00	10/30/2018	
5/1/2019	\$ -	\$ 3,875.00	\$ 3,875.00	4/26/2019	
11/1/2019	\$ 310,000.00	\$ 3,875.00	\$ 313,875.00	10/29/2019	
5/1/2020	\$ -	\$ 1,937.50	\$ 1,937.50	4/22/2020	
11/1/2020	\$ 310,000.00	\$ 1,937.50	\$ 311,937.50	10/29/2020	BOND RETIRED

### BUILDING BONDS of 2018 JUNE 1, 2018 - \$4,735,000.00

Date	Principal	Interest	Total	Date Paid	Notes
6/1/2019	\$ -	\$ 121,375.00	\$ 121,375.00	5/30/2019	
12/1/2019	\$ -	\$ 60,687.50	\$ 60,687.50	11/22/2019	
6/1/2020	\$ 1,135,000.00	\$ 60,687.50	\$ 1,195,687.50	5/28/2020	
12/1/2020	\$ -	\$ 46,500.00	\$ 46,500.00	11/30/2020	
6/1/2021	\$ 1,200,000.00	\$ 46,500.00	\$ 1,246,500.00	5/28/2021	
12/1/2021	\$ -	\$ 31,500.00	\$ 31,500.00		
6/1/2022	\$ 1,200,000.00	\$ 31,500.00	\$ 1,231,500.00		
12/1/2022	\$ -	\$ 15,750.00	\$ 15,750.00		
6/1/2023	\$ 1,200,000.00	\$ 15,750.00	\$ 1,215,750.00		RETIRES BOND

### TRANSPORTATION BONDS JULY 2, 2019 - \$600,000

Date	Principal	Interest	Total	Date Paid	Notes
7/1/2021	\$ 600,000.00	\$ 24,000.00	\$ 624,000.00		RETIRES BOND

## Purchase Order Register

Options: Year: 2021-2022, Fund: GEN FUND-FOR OP, Date Range: 7/1/2021 - 6/30/2022

PO No	Date	Vendor No	Vendor	Description	Amount
1	07/01/2021	1063	COMMON GOAL SYSTEMS INC.	TEACHER EASE	11,580.90
2	07/01/2021	3243	ARCHWAY	TEXTBOOKS	33,503.68
3	07/01/2021	5	MUNICIPAL ACCOUNTING SYSTEMS, INC	COMPUTER MAINTENANCE	7,611.25
5	07/01/2021	702	ORES	ORES FEES	1,025.00
6	07/01/2021	941	OKLAHOMA TURNPIKE AUTHORITY	TURNPIKE FEES	155.45
7	07/01/2021	997	UMB BANK	PAYING AGENT FEES	900.00
8	07/01/2021	315	OKLAHOMA SCHOOL ASSURANCE GROU	WORKER'S COMP INS.	15,408.00
9	07/01/2021	67	OSSBA	MEMBERSHIP DUES/POLICY MAINT	17,550.00
12	07/01/2021	70017	SYSCO OKLAHOMA LLC	FOOD PURCHASES	54,331.29
15	07/01/2021	531	ALCOHOL & DRUG TESTING, INC.	DRUG TESTING BUS DRIVERS	321.10
17	07/01/2021	3387	ED ADMIN SRVS, INC	CONSULTING SERVICES	30,000.00
18	07/01/2021	137	PERMIT DIVISION	PERMIT FOR ALARM SYSTEM	17.00
20	07/01/2021	115	OFFICE DEPOT	OFFICE SUPPLIES	1,252.24
21	07/01/2021	204	QUILL CORPORATION	OFFICE SUPPLIES	10,000.00
22	07/01/2021	58	AT&T MOBILITY	CELL PHONES MONTHLY SERVICE	4,519.37
24	07/01/2021	3394	STATION 27, INC	FUEL FOR BUSES	13,000.00
25	07/01/2021	285	THE BECKMAN COMPANY	SURETY BONDS	1,532.50
28	07/01/2021	3484	CONTRACT PAPER GROUP, INC.	COPY PAPER	5,580.00
30	07/01/2021	119	SAM'S CLUB MC/SYNCB	MISCELLANEOUS SUPPLIES	5,348.52
31	07/01/2021	70087	WAL MART COMMUNITY/SYNCB	GENERAL OFFICE SUPPLIES	1,090.86
32	07/01/2021	3556	GABBART COMMUNICATIONS	WEB HOSTING	4,099.00
33	07/01/2021	3558	POWERSCHOOL GROUP LLC	COMPUTER SOFTWARE	6,775.05
34	07/01/2021	3554	TLC ENTERPRISES LLC	MAINTENANCE AND SUPPLIES	9,953.65
37	07/01/2021	1038	PRECISION BUSINESS MACHINES, INC.	COLD LAMINATE AND POSTER PAPER	1,964.20
39	07/01/2021	3610	HEARTS FOR HEARING	HEARING IMPAIRED	1,370.00
40	07/01/2021	3162	SCHOOL HEALTH CORPORATION	NURSING SUPPLIES	450.00
42	07/01/2021	3621	PROFESSIONAL OKLAHOMA EDUCATORS	PAYROLL WORKSHOP	110.00
43	07/01/2021	45	REID PRINTING	SCHOOL LOGO ENVELOPES	1,064.85
46	07/01/2021	3667	COLLECT ED	E-RATE SERVICES	3,000.00
47	07/01/2021	3693	PROSPERITY BANK	CENTRAL OFFICE MISCELLANEOUS	34,364.82
48	07/01/2021	500	DEVELOPMENT SERVICES	ELEVATOR PERMIT	152.00
49	07/01/2021	3736	OKLAHOMA SCHOOLS INSURANCE	GENERAL LIABILITY	16,437.00
50	07/01/2021	3737	FOLLETT SCHOOL SOLUTIONS	LIBRARY LICENSE	2,624.34
51	07/01/2021	942	RENAISSANCE LEARNING	PRODUCTS AND SERVICES	6,309.00
52	07/01/2021	388	HOUGHTON HARCOURT PUBLISHING	TEST MATERIALS	1,405.90
53	07/01/2021	326	WALKER STAMP & SEAL	SIGNATURE STAMPS	148.50
55	07/01/2021	3795	BIMBO BAKERIES USA	BREAD	5,305.89
56	07/01/2021	3795	BIMBO BAKERIES USA	BREAD	5,305.89
57	07/01/2021	143	STATE DEPARTMENT OF HEALTH	FOOD LICENSE PERMIT	125.00
59	07/01/2021	3488	BUDDY'S PRODUCE, INC.	FRUITS & VEGETABLES	5,830.55
60	07/01/2021	3930	HERTZBERT-NEW METHOD INC	TEXTBOOK BINDING	1,000.00
61	07/01/2021	3045	AT&T	SUBSCRIBER/ROUTER ID	16,000.00
63	07/01/2021	3999	VIZAVANCE	CHILDREN'S VISION SCREENING	100.00
65	07/01/2021	3212	NCS PEARSON, INC.	TESTING	1,920.05

## Purchase Order Register

Options: Year: 2021-2022, Fund: GEN FUND-FOR OP, Date Range: 7/1/2021 - 6/30/2022

PO No	Date	Vendor No	Vendor	Description	Amount
66	07/01/2021	96	OKLAHOMA COUNTY ELECTION BOARD	ELECTION EXPENSE	3,232.62
68	07/01/2021	104	HOUGHTON MIFFLIN HARCOURT	READING COUNTS	1,600.00
70	07/01/2021	4035	FRANCIS TUTTLE TECH CENTER	CPR WORKSHOP	830.00
71	07/01/2021	4042	HILAND DAIRY FOODS COMPANY, LLC	MILK	19,358.79
73	07/01/2021	690	CAPITAL ONE	MISCELLANEOUS SUPPLIES	338.62
74	07/01/2021	4079	ON BROADWAY PIZZA CO	FOOD	8,232.25
76	07/01/2021	99995	FNB COMMUNITY BANK	ACCRUED INTEREST/BANK FEES	7,285.55
79	07/01/2021	3247	PRINT FINISHING SYSTEMS	LAMINATOR FILM	1,006.58
81	07/01/2021	3617	OAK HALL CAP & GOWN	CAP AND GOWNS	119.67
85	07/01/2021	4084	schoolSAFEid, LLC	SOFTWARE LICENSE	998.00
90	07/01/2021	4125	LIMINEX INC	TECHNOLOGY APPLICATION	5,512.50
94	07/01/2021	70018	OKLAHOMA DEPT. OF HUMAN SERVICES	COMMODITY FEE	555.67
97	07/01/2021	626	SCHOOL SPECIALTY, LLC	ISPIRE DISTANCE LEARNING	520.00
106	07/01/2021	1054	CCOSA	TLC TRAINING	1,130.00
113	07/01/2021	3294	DIRSEC CORPORATE OFFICE	THREAT PREVENTION SUBSCRIPTION	12,931.20
115	07/01/2021	3711	KISS INSTITUTE	ROBOTICS	600.00
123	07/01/2021	4172	JONES SUPPLY COMPANY	GRADUATION SUPPLIES	25.00
124	07/01/2021	4079	ON BROADWAY PIZZA CO	PIZZA	1,469.50
125	07/01/2021	924	GUIAR CENTER, 451	MICROPHONE	279.98
130	07/01/2021	376	PUTNAM COMPANY	AUDITING SERVICES	5,500.00
131	07/01/2021	4189	PHILLIPS MURRAH P.C.	ATTORNEY FEES	2,816.00
132	07/01/2021	3289	TEEL OSWALD, M.ED	SPECIAL EDUCATION TESTING	5,000.00
135	07/01/2021	11	THOMPSON SCHOOL BOOK	TEXTBOOKS	10,000.00
137	07/01/2021	4198	EDMOND SCHOOLS TRANSPORTATION DEPT	BUS DRIVER TRAINING	700.00
142	07/01/2021	649	RAINBOW PENNANT, INC.	MISCELLANEOUS PRINTING	2,000.00
153	07/01/2021	3588	OK JUNIOR ACADEMIC BOWL ASSN	ACADEMIC TEAM REGISTRATION	150.00
159	07/01/2021	3824	PRIMEX WIRELESS	SYNC 72MHZ ANALOG CLOCK 12.5" BLACK	244.84
160	07/01/2021	3637	SHELLEY RYLAND	SPEECH PATHOLOGIST	90.00
164	07/01/2021	4234	BAVCO AUDIO	CONTROL CABLE REPAIR	358.00
165	07/01/2021	4235	PENDERS MUSIC COMPANY	BAND MUSIC	840.37
166	07/01/2021	3709	EDMOND MUSIC	BAND MUSIC	2,040.68
176	07/01/2021	4252	RIVERSIDE INSIGHTS	COGAT TESTING	699.05
179	07/01/2021	4111	OKLAHOMA SCHOOL PICTURES	BADGES	284.00
180	07/01/2021	4260	SUMMER ONE	INK FOR RISO MACHINE	300.00
184	07/01/2021	80717	JOSEPH M PIERCE	REIMBURSEMENT ON CELL PHONE AND DROP BOX	827.88
200	07/01/2021	3451	OKLAHOMA ASSOC. PUPIL TRANSPORTATIO	BUS DRIVING TRAINING	360.00
202	07/01/2021	4266	AMERICAN SOLUTIONS FOR BUSINESS	COVID-19 SUPPLIES	1,995.00
203	07/01/2021	4267	NEWSELA	DISTANCE LEARNING DISTRICT SUITE	8,320.00
205	07/01/2021	3567	HOBBY LOBBY DEPARTMENT	OFFICE DECORATIONS	541.91
206	07/01/2021	4270	HICKMAN LAW GROUP	LEGAL SERVICES	1,000.00
215	07/01/2021	4208	IXL LEARNING	SITE LICENSE	14,915.00

## Purchase Order Register

Options: Year: 2021-2022, Fund: GEN FUND-FOR OP, Date Range: 7/1/2021 - 6/30/2022

PO No	Date	Vendor No	Vendor	Description	Amount
217	07/01/2021	4278	OKLAHOMA PUBLIC SCHOOL RESOURCE CTR	MEMBERSHIP DUES	2,500.00
218	07/01/2021	4279	TULSA FRUIT COMPANY	FOOD	1,253.56
219	07/01/2021	4280	DIXIE MCHENDRY	MASK FOR COVID	225.00
225	07/01/2021	103	ROSS TRANSPORTATION	BUS INSPECTIONS	3,534.13
226	07/01/2021	4080	SHI INTERNATIONAL CORP	MATH SOFTWARE	2,857.68
227	07/01/2021	4197	COAST AUDIO VIDEO	FREIGHT CHARGES	324.88
228	07/01/2021	3637	SHELLEY RYLAND	SPEECH PATHOLOGIST	30,000.00
230	07/01/2021	3380	APPLE INC. EDUCATION	I-PADS	10,913.00
231	07/01/2021	4284	DAVID KEY	REFUND LUNCH ACCOUNT	32.50
232	07/01/2021	3843	PHONAK LLC	SPECIAL EDUCATION CLASSROOM SUPPLIES	1,508.99
233	07/01/2021	1083	AIC MEDICAL	AUDIOMETER CALIBRATION	500.00
234	07/01/2021	4286	N2Y, LLC	CURRICULUM	1,125.66
235	07/01/2021	4290	AMERICAN TELCOM, INC	TELEPHONE REPAIR	308.75
236	07/01/2021	4291	AMPLIFY EDUCATION, INC	DIBELS 8TH ED ANNUAL LICENSE	4,550.00
237	07/01/2021	4292	FIELDHOUSE MEDIA, LLC	PROFESSIONAL DEVELOPMENT	1,500.00
238	07/01/2021	4213	CHRISTINA WYNN	REFUND LUNCH ACCOUNT	49.00
239	07/01/2021	50186	Rebecca Drinkaus	REFUND LUNCH ACCOUNT	175.00
240	07/01/2021	4293	JON LAIRD CLOWDUS	SECURITY SERVICES	1,370.00
241	07/01/2021	4294	FELIX A VALADEZ	SECURITY SERVICES	760.00
242	07/01/2021	4295	JESSE BUTTS	SECURITY SERVICES	460.00
243	07/01/2021	4296	MICHAEL DON ROOF	SECURITY SERVICES	480.00
244	07/01/2021	4297	STEVEN JOHNSON	SECURITY SERVICES	310.00
245	07/01/2021	80726	NICOLE M RIHN	REIMBURSEMENT FOR FINGERPRINTS	57.25
246	07/01/2021	80728	AUBREY M STANLEY	REIMBURSEMENT FOR FINGERPRINTS	57.25
247	07/01/2021	80423	PAULA PARROTT	INSTRUCTIONAL TRAINING	5,040.00
248	07/01/2021	80733	JEREMY J EVANS	REIMBURSEMENT FOR BUS DRIVING TRAINING	157.75
249	07/01/2021	4298	AUDREA GEORGE	SECURITY SERVICES	1,050.00
255	07/01/2021	4305	CANDOR	GRAPHIC DESIGN OF NEWSLETTERS	4,725.00
256	07/01/2021	3703	AFLAC	PREMIUM FOR JANIS MUNSON	30.56
257	07/01/2021	4306	BRIDGE TOWER OPCO, LLC	ADVERTISING	1,500.00
258	07/01/2021	80662	MICHELLE R FETTERS	REFUND ON OVERPAYMENT ON OMES	34.35
259	07/01/2021	4309	NATIONAL BUSINESS INSTITUTE	SEMINAR	648.00
262	07/01/2021	3212	NCS PEARSON, INC.	NNAT3 ONLINE LICENSE	262.50
263	07/01/2021	4315	RENZULLI LEARNING LLC	RLS USER LICENSE	250.00
264	07/01/2021	4316	QUIK PRINT	PRINTING AND BINDING	1,603.66
265	07/01/2021	4317	VT SERVICES INC.	TECHNOLOGY REPAIR	500.00
275	07/01/2021	4319	SCOTT BALLARD	SECURITY SERVICES	150.00
276	07/01/2021	4321	KYLE WATT THOMAS	GOLF INSTRUCTOR	1,500.00
277	07/01/2021	4322	JESSICA LONG	REFUND LUNCH ACCOUNT	110.00
278	07/01/2021	4324	RACHEL REID	REFUND LUNCH ACCOUNT	89.50

## Purchase Order Register

Options: Year: 2021-2022, Fund: GEN FUND-FOR OP, Date Range: 7/1/2021 - 6/30/2022

PO No	Date	Vendor No	Vendor	Description	Amount
279	07/01/2021	3004	PRODUCTIVE CORPORATION	SERVER PROTECTION	2,171.25
280	07/01/2021	4326	Kelsey Friend	REFUND LUNCH ACCOUNT	50.00
281	07/01/2021	645	UNIVERSITY OF OKLAHOMA HSC	WORKSHOP AUTISM SPECTRUM DISORDER	450.00
284	07/01/2021	4082	UNITED SYSTEMS, INC	INTERNET REPAIRS	1,500.00
286	07/01/2021	4252	RIVERSIDE INSIGHTS	COGAT TESTING	1,306.00
287	07/01/2021	4330	MICHELLE DOHRWARDT	REFUND LUNCH ACCOUNT	101.25
288	07/01/2021	812	GILL REPROGRAPHICS,INC.	POSTERS TO SUPPORT BOND ISSUE	510.00
303	07/01/2021	4341	QUO VADIMUS LLC	NETWORKING MAINTENANCE/INTERNET REPAIR	10,000.00
304	07/01/2021	4345	NATIONAL BUS SALES INC	BUS REPAIR	1,617.82
305	07/01/2021	4271	EDPUZZLE, INC	GOALS FOR LEARNING	1,450.00
306	07/01/2021	4327	NOTABLE, INC	RENEWAL OF LICENSE FOR 12 MONTHS	1,683.00
307	07/01/2021	3663	BRAIN POP	ONLINE CURRICULUM	3,745.00
308	07/01/2021	3653	EDMENTUM	SCIENCE LIBRARY ONLINE LICENSE	8,505.00
309	07/01/2021	4192	NoRedInk Corp	ONLINE CURRICULUM	5,000.00
310	07/01/2021	4273	NEARPOD, INC	ONLINE CURRICULUM	3,784.66
311	07/01/2021	3664	EXPLORE LEARNING	ONLINE CURRICULUM	5,445.00
312	07/01/2021	4276	FIREPLACE INC (SMORE)	ONLINE CURRICULUM	999.99
313	07/01/2021	4347	TEACHER SYNERGY, LLC	ONLINE CURRICULUM	3,700.00
314	07/01/2021	4275	SCREENCASTIFY	ONLINE CURRICULUM	850.00
315	07/01/2021	4272	GENERATION GENIUS, INC	ONLINE CURRICULUM	995.00
316	07/01/2021	4265	MIMEO.COM, INC	SCHOOL PLANNERS	2,244.56
317	07/01/2021	4274	SEESAW LEARNING, INC	STUDENT LICENSE	2,365.00
318	07/01/2021	4349	THE SAMPSON GROUP	LEADERSHIP DEVELOPMENT	7,000.00
319	07/01/2021	3737	FOLLETT SCHOOL SOLUTIONS	LIBRARY BOOKS	0.00
<b>Non-Payroll Total:</b>					<b>\$613,529.01</b>
<b>Payroll Total:</b>					<b>\$30,250.59</b>
<b>Report Total:</b>					<b>\$643,779.60</b>

## Purchase Order Register

Options: Year: 2021-2022, Fund: Building, Date Range: 7/1/2021 - 6/30/2022

PO No	Date	Vendor No	Vendor	Description	Amount
1	07/01/2021	494	THE HOME DEPOT	MISCELLANEOUS	2,000.00
2	07/01/2021	49	ALERT 360	FIRE MONITORING	2,500.00
3	07/01/2021	3148	TREATS SOLUTIONS	CHEMICALS	18,444.18
4	07/01/2021	3693	PROSPERITY BANK	BUILDING SUPPLIES	3,039.98
5	07/01/2021	77	EDMOND SAFE AND LOCK	KEYS	500.00
6	07/01/2021	3333	WINDSTREAM NUVOX, LLC	TELEPHONE	5,230.21
7	07/01/2021	4	OKLAHOMA NATURAL GAS	GAS SERVICE	10,200.00
8	07/01/2021	3346	CITY GREASE	CLEAN GREASE TRAP	2,450.00
9	07/01/2021	3	OKLAHOMA GAS& ELECTRIC	ELECTRIC	108,682.00
13	07/01/2021	3554	TLC ENTERPRISES LLC	LEASE AND MAINTENANCE ON COPIERS	39,140.00
14	07/01/2021	3386	OTIS ELEVATOR	ELEVATOR SERVICE CONTRACT	2,204.16
15	07/01/2021	3644	SUPERIOR LINEN	TOWEL SERVICE	1,662.08
16	07/01/2021	3730	DASH EQUIPMENT	EQUIPMENT REPAIR	1,573.61
17	07/01/2021	3736	OKLAHOMA SCHOOLS INSURANCE	PROPERTY INSURANCE RENEWAL	111,698.00
19	07/01/2021	3362	FIRE EXTINGUISHER SALES & SERVICE	INSPECTION OF EXTINGUISHERS	1,409.10
21	07/01/2021	70038	CITY OF OKLAHOMA CITY	WATER UTILITIES	6,878.15
23	07/01/2021	2026	VOSS LIGHTING	LIGHT BULBS	1,163.80
24	07/01/2021	3823	FER WASTE SERVICES LLC	TRASH HAULING	5,000.00
26	07/01/2021	597	HAGAR RESTAURANT	REPAIRS ON OVEN	1,064.45
28	07/01/2021	3932	GREEN COUNTRY ELECTRIC AND SUPPLY	ELECTRICAL SERVICE	14,844.57
29	07/01/2021	3352	CLASSIC PAPER SUPPLY, INC.	CHEMICAL CLEANING SUPPLIES	414.00
30	07/01/2021	3201	P & L FIRE PROTECTION INC	FIRE ALARM INSPECTION	2,500.00
32	07/01/2021	3980	RED DIRT SEPTIC	WORK ON SEWER LINE	1,855.00
33	07/01/2021	3314	EARTHSMART CONTROLS	REPAIRS AND MAINTENANCE	6,000.00
37	07/01/2021	503	LOWE'S	BUILDING AND MAINTENANCE SUPPLIES	2,000.00
38	07/01/2021	4030	MOTHER NATURES PEST	PEST CONTROL	10,000.00
39	07/01/2021	4000	GREENTURF INC	FOOTBALL FIELD LAWN MAINT	20,864.47
44	07/01/2021	538	EAGLE MECHANICAL, INC.	HEAT AND AIR REPAIR	10,000.00
48	07/01/2021	119	SAM'S CLUB MC/SYNCB	BUILDING SUPPLIES	1,049.86
56	07/01/2021	4196	EDGE COMMUNICATIONS	TELECOMMUNICATIONS	1,990.20
57	07/01/2021	4200	MOUNTAIN INVESTMENTS LLC	GEO THERMAL MAINTENANCE	2,500.00
60	07/01/2021	4202	GREEN LION PLUMBING INC	PLUMBING MAINTENANCE	500.00
61	07/01/2021	474	BROOKS INDUSTRIES	ICE MACHINE REPAIR	600.00
69	07/01/2021	4269	ChemStation of Oklahoma	HAND SANITIZER	1,470.75
70	07/01/2021	380	REX PLAYGROUND EQUIPMENT	MULCH FOR GROUNDS	3,100.00
71	07/01/2021	4288	METRO MOWING SERVICE	BRUSH HOG AND LIMB PICKUP AND HAUL OFF	8,515.00
72	07/01/2021	444	ROTO ROOTER	CLEAR CLOGGED SEWER DRAINS	1,528.80
73	07/01/2021	4299	CORNERSTONE PLUMBING	PLUMBING SERVICE	189.00
74	07/01/2021	4300	OKLAHOMA STEAMCLEAN, INC	WATER CLEAN UP	500.00
76	07/01/2021	3805	PK & EQUIPMENT	JOHN DEERE XUV825M S4 (MY20)	126.54
79	07/01/2021	206	OKLAHOMA COUNTY CLERK	REVALUATION FEES	46,020.65
80	07/01/2021	3578	ENDEX OF OKLAHOMA, INC.	SOUND SYSTEM REPAIRS	270.00
81	07/01/2021	58	AT&T MOBILITY	SCHOOL PHONES AND HOT SPOTS	8,000.00

## Purchase Order Register

Options: Year: 2021-2022, Fund: Building, Date Range: 7/1/2021 - 6/30/2022

PO No	Date	Vendor No	Vendor	Description	Amount
82	07/01/2021	3045	AT&T	TELEPHONE SERVICES	5,000.00
85	07/01/2021	4344	HIS PAINT MANUFACTURING CO LLC	PAINT	1,000.00
87	07/01/2021	4064	WRIGHT TRACTORS	TRACTOR REPAIR	500.00
88	07/01/2021	4346	TREATS CLEANING SOLUTIONS LLC	STRIPPING AND WAXING THE FLOORS	1,000.00
89	07/01/2021	4320	ROBERT L HINER	GYM FLOOR CLEANING SYSTEM	1,000.00
90	07/01/2021	444	ROTO ROOTER	CLEAN OUT STOPPED UP DRAINS	1,000.00
91	07/01/2021	4350	INDUSTRIAL COMMERCIAL ENTERPRISES	WORK ON FRENCH DRAIN	696.00
<b>Non-Payroll Total:</b>					<b>\$479,874.56</b>
<b>Payroll Total:</b>					<b>\$9,159.23</b>
<b>Report Total:</b>					<b>\$489,033.79</b>



**Important Messages**

THANK YOU FOR CHOOSING PROSPERITY BANK FOR YOUR CREDIT CARD NEEDS.

*Foundation* #390.26  
*Activity Fund* 198.72  
*Gen. Fund* 34.28

**TRANSACTIONS THIS BILLING PERIOD**

Transaction Date	Posting Date	Reference Number	Transaction Description	\$ Amount
------------------	--------------	------------------	-------------------------	-----------

TRANSACTIONS

Account Level

06/14	06/14	00000000000614001040292	PAYMENT - THANK YOU!	\$5,142.89-
06/14	06/14	00000000000614001040300	PAYMENT - THANK YOU!	\$1,395.71-
06/14	06/14	00000000000614001040318	PAYMENT - THANK YOU!	\$397.63-

**Card #3741-JOSEPH PIERCE**

06/05	06/06	VT211573292000010000627	GIANT TV WWW.GIANT.TV NM	\$9.98+
06/07	06/08	VT211592560000010000515	AMZN Mktp US*2X8VQ9Z62 Amzn.com/bill WA	\$19.99+
06/07	06/08	VT211592560000010000519	AMZN Mktp US*2X5GJ96A1 Amzn.com/bill WA	\$95.55+
06/08	06/09	VT211602560000010000634	AMZN Mktp US Amzn.com/bill WA	\$21.50-
06/10	06/11	VT211622560000010002002	AMZN Mktp US*2X6CW6MR0 Amzn.com/bill WA	\$14.99+
06/11	06/13	VT211643292000010000116	AMZN Mktp US Amzn.com/bill WA	\$19.99-
06/11	06/13	VT211643292000010000146	Amazon.com*2X3CG2B32 Amzn.com/bill WA	\$28.00+
06/12	06/13	VT211643292000010000500	AMZN Mktp US*2X79U0DW0 Amzn.com/bill WA	\$85.92+
06/12	06/13	VT211643292000010000707	AMZN Mktp US*2X7P926K0 Amzn.com/bill WA	\$53.01+
06/13	06/15	VT211662560000010000113	AMZN Mktp US*2X6JH6KB0 Amzn.com/bill WA	\$210.86+
06/14	06/15	VT211662560000010001684	AMZN Mktp US*2X5KE2232 Amzn.com/bill WA	\$40.47+
06/18	06/20	VT211712560000010001139	MICROSOFT#G004310887 MSBILL.INFO WA	\$39.66+
06/21	06/22	VT211732560000010000154	AMZN Mktp US*210B023E2 Amzn.com/bill WA	\$26.24+
06/23	06/24	VT211752560000010003226	BATTERIES PLUS #0097 EDMOND OK	\$46.95+
06/23	06/24	VT211752560000010001494	AMZN Mktp US*2186D3HY0 Amzn.com/bill WA	\$10.99+
06/26	06/27	VT211783296000010001533	AMZN MKTP US*2953E4N61 AMZN.COM/BILL WA	\$109.99+
<b>Total For JOSEPH PIERCE</b>				<b>\$751.11+</b>

**Card #4392-MARLENE MARTINEZ**

06/08	06/09	VT211602560000010000822	MBM CORPORATION N CHARLESTON SC	\$140.93+
06/09	06/10	VT211612560000010001841	CHEERLEADING COMPANY 800-4114105 TX	\$550.00-
06/15	06/17	VT211682560000010000526	SCHLOTZSKYS #102170 EDMOND OK	\$99.90+
06/15	06/15	VT211662560000010001576	ALL AMERICAN PIZZA EDMOND OK	\$46.90+
06/17	06/17	VT211682560000010002030	ALL AMERICAN PIZZA EDMOND OK	\$51.92+
06/17	06/18	VT211692560000010002121	ALL AMERICAN PIZZA EDMOND OK	\$82.50+
<b>Total For MARLENE MARTINEZ</b>				<b>\$127.85-</b>

**2021 Total Year-to-Date**

Total fees charged in 2021	\$0.00
Total interest charged in 2021	\$0.00

## Payment Register

Options: Year: 2020-2021, Fund: GEN FUND-FOR OP, Date Range: 6/30/2021 - 6/30/2021, Print Payroll Payments: False

Payment No	Date	Vendor No	Vendor	Type	Date Voided	Void Amount	Amount
3014	06/30/2021	3045	AT&T		06/30/2021	\$14,565.87	\$0.00
3015	06/30/2021	58	AT&T MOBILITY				\$1,486.14
3016	06/30/2021	3387	ED ADMIN SRVS, INC				\$5,000.00
3017	06/30/2021	3737	FOLLETT SCHOOL SOLUTIONS				\$8,201.04
3018	06/30/2021	4270	HICKMAN LAW GROUP				\$843.75
3019	06/30/2021	5	MUNICIPAL ACCOUNTING SYSTE				\$448.00
3020	06/30/2021	941	OKLAHOMA TURNPIKE AUTHORI				\$4.50
3021	06/30/2021	80423	PAULA PARROTT				\$300.00
3022	06/30/2021	3693	PROSPERITY BANK				\$34.28
3023	06/30/2021	4351	DR. RENE D. AXTELL				\$276.25
3024	06/30/2021	4252	RIVERSIDE INSIGHTS				\$801.20
3025	06/30/2021	3637	SHELLEY RYLAND				\$720.00
3026	06/30/2021	3676	TODAYS THERAPY				\$375.00
3027	06/30/2021	997	UMB BANK				\$300.00
3028	06/30/2021	997	UMB BANK		06/30/2021	\$600.00	\$0.00
3029	06/30/2021	997	UMB BANK				\$300.00
3030	06/30/2021	3045	AT&T				\$1,315.00
<b>Non-Payroll Total:</b>							<b>\$20,405.16</b>
<b>Payroll Total:</b>							<b>\$0.00</b>
<b>Balance Foward:</b>							<b>\$5,511,059.16</b>
<b>Total:</b>							<b>\$5,531,464.32</b>

## Payment Register

Options: Year: 2021-2022, Fund: GEN FUND-FOR OP, Date Range: 7/16/2021 - 7/20/2021, Print Payroll Payments: False

Payment No	Date	Vendor No	Vendor	Type	Date Voided	Void Amount	Amount
23	07/16/2021	285	THE BECKMAN COMPANY				\$750.00
24	07/16/2021	3667	COLLECT ED				\$394.52
25	07/16/2021	4271	EDPUZZLE, INC				\$1,450.00
26	07/16/2021	3556	GABBART COMMUNICATIONS				\$4,099.00
27	07/16/2021	4125	LIMINEX INC				\$2,512.50
28	07/16/2021	5	MUNICIPAL ACCOUNTING SYSTE				\$6,840.00
29	07/16/2021	4345	NATIONAL BUS SALES INC				\$1,617.82
30	07/16/2021	4273	NEARPOD, INC				\$3,784.66
31	07/16/2021	143	STATE DEPARTMENT OF HEALTH				\$125.00
32	07/16/2021	4278	OKLAHOMA PUBLIC SCHOOL RES				\$2,500.00
33	07/16/2021	315	OKLAHOMA SCHOOL ASSURANC				\$15,408.00
34	07/16/2021	3736	OKLAHOMA SCHOOLS INSURANC				\$16,437.00
35	07/16/2021	67	OSSBA				\$6,100.00
36	07/16/2021	3558	POWERSCHOOL GROUP LLC				\$6,775.05
37	07/16/2021	4341	QUO VADIMUS LLC				\$1,935.00
38	07/16/2021	942	RENAISSANCE LEARNING				\$6,309.00
39	07/16/2021	4084	schoolSAFEid, LLC				\$998.00
40	07/16/2021	4274	SEESAW LEARNING, INC				\$2,365.00
41	07/16/2021	4276	FIREPLACE INC (SMORE)				\$999.00
63	07/19/2021	4267	NEWSELA				\$8,320.00
64	07/19/2021	649	RAINBOW PENNANT, INC.				\$45.00
65	07/19/2021	103	ROSS TRANSPORTATION				\$3,534.13
66	07/19/2021	997	UMB BANK				\$300.00
67	07/20/2021	531	ALCOHOL & DRUG TESTING, INC.				\$100.00
68	07/20/2021	4192	NoRedInk Corp				\$5,000.00
69	07/20/2021	67	OSSBA				\$160.00
<b>Non-Payroll Total:</b>							<b>\$98,858.68</b>
<b>Payroll Total:</b>							<b>\$28,591.18</b>
<b>Balance Foward:</b>							<b>\$30,250.59</b>
<b>Total:</b>							<b>\$157,700.45</b>

## Payment Register

Options: Year: 2020-2021, Fund: Building, Date Range: 6/30/2021 - 6/30/2021, Print Payroll Payments: False

Payment No	Date	Vendor No	Vendor	Type	Date Voided	Void Amount	Amount
513	06/30/2021	4340	ABSOLUTE RESTAURANT SERVICE				\$423.36
514	06/30/2021	70038	CITY OF OKLAHOMA CITY				\$680.86
515	06/30/2021	3314	EARTHSMART CONTROLS				\$720.00
516	06/30/2021	77	EDMOND SAFE AND LOCK				\$31.50
517	06/30/2021	3932	GREEN COUNTRY ELECTRIC AND				\$1,706.00
518	06/30/2021	4344	HIS PAINT MANUFACTURING CO				\$94.95
519	06/30/2021	494	THE HOME DEPOT				\$146.65
520	06/30/2021	503	LOWE'S				\$479.27
521	06/30/2021	4288	METRO MOWING SERVICE				\$890.00
522	06/30/2021	4030	MOTHER NATURES PEST				\$1,350.00
523	06/30/2021	3	OKLAHOMA GAS& ELECTRIC				\$7,187.98
524	06/30/2021	3728	OKLAHOMA ROOFING				\$435.19
525	06/30/2021	4	OKLAHOMA NATURAL GAS				\$915.00
526	06/30/2021	3201	P & L FIRE PROTECTION INC				\$2,955.00
527	06/30/2021	3148	TREATS SOLUTIONS				\$1,581.34
528	06/30/2021	2026	VOSS LIGHTING				\$191.40
529	06/30/2021	4	OKLAHOMA NATURAL GAS				\$422.22
<b>Non-Payroll Total:</b>							<b>\$20,210.72</b>
<b>Payroll Total:</b>							<b>\$0.00</b>
<b>Balance Foward:</b>							<b>\$590,524.80</b>
<b>Total:</b>							<b>\$610,735.52</b>

## Payment Register

**Options:** Year: 2021-2022, Fund: Building, Date Range: 7/16/2021 - 7/16/2021, Payment Range: 16 - 28, Print Payroll  
 Payments: False

Payment No	Date	Vendor No	Vendor	Type	Date Voided	Void Amount	Amount
16	07/16/2021	49	ALERT 360				\$154.80
17	07/16/2021	3314	EARTHSMART CONTROLS				\$300.00
18	07/16/2021	3823	FER WASTE SERVICES LLC				\$352.00
19	07/16/2021	4000	GREENTURF INC				\$1,058.75
20	07/16/2021	4344	HIS PAINT MANUFACTURING CO				\$94.95
21	07/16/2021	4350	INDUSTRIAL COMMERCIAL ENTE				\$696.00
22	07/16/2021	4030	MOTHER NATURES PEST				\$675.00
23	07/16/2021	3	OKLAHOMA GAS& ELECTRIC				\$10,750.00
24	07/16/2021	3736	OKLAHOMA SCHOOLS INSURANC				\$111,698.00
25	07/16/2021	3386	OTIS ELEVATOR				\$2,204.16
26	07/16/2021	3554	TLC ENTERPRISES LLC				\$1,595.00
27	07/16/2021	3148	TREATS SOLUTIONS				\$23.68
28	07/16/2021	3333	WINDSTREAM NUVOX, LLC				\$47.52
<b>Non-Payroll Total:</b>							<b>\$129,649.86</b>
<b>Payroll Total:</b>							<b>\$0.00</b>
<b>Balance Foward:</b>							<b>\$9,159.23</b>
<b>Total:</b>							<b>\$138,809.09</b>

## Payment Register

Options: Year: 2020-2021, Fund: ACTIVITY FUND, Date Range: 6/1/2021 - 6/30/2021, Print Payroll Payments: False

Payment No	Date	Vendor No	Vendor	Type	Date Voided	Void Amount	Amount
274	06/03/2021	690	CAPITAL ONE				\$109.68
275	06/07/2021	119	SAM'S CLUB MC/SYNCB				\$372.67
276	06/07/2021	3693	PROSPERITY BANK		06/07/2021	\$1,396.01	\$0.00
277	06/08/2021	3693	PROSPERITY BANK				\$1,395.71
278	06/16/2021	4059	KAREN PICA				\$2,250.00
279	06/16/2021	80458	BEVERLY M DUNN				\$500.00
280	06/16/2021	3632	MALISA RADDATZ				\$2,250.00
281	06/30/2021	80747	MARCUS L DYER				\$225.00
282	06/30/2021	119	SAM'S CLUB MC/SYNCB				\$220.50
283	06/30/2021	690	CAPITAL ONE				\$48.78
284	06/30/2021	3693	PROSPERITY BANK				\$198.72
<b>Non-Payroll Total:</b>							<b>\$7,571.06</b>
<b>Payroll Total:</b>							<b>\$0.00</b>
<b>Balance Foward:</b>							<b>\$83,074.91</b>
<b>Total:</b>							<b>\$90,645.97</b>

# Oakdale Public School

## Revenue/Expenditure Summary

**Options:** Fund: 61, Date Range: 7/1/2020 - 6/30/2021

	<b>Begin Balance</b>	<b>Receipts</b>	<b>Adjusting Entries</b>	<b>Payments</b>	<b>Cash End Balance</b>	<b>Unpaid POs</b>	<b>End Balance</b>
801 SPORTS	\$0.00	\$15,580.64	\$19,084.27	\$14,471.46	\$20,193.45	\$0.00	\$20,193.45
810 CHEER	\$0.00	\$3,552.65	\$82.97	\$3,151.15	\$484.47	\$0.00	\$484.47
831 CONCESSIONS	\$0.00	\$0.00	\$11,436.14	\$91.50	\$11,344.64	\$0.00	\$11,344.64
901 CLASS PROJECTS	\$0.00	\$2,732.71	\$778.56	\$3,237.41	\$273.86	\$0.00	\$273.86
930 DAYCARE	\$0.00	\$45,832.63	\$1,383.29	\$45,630.29	\$1,585.63	\$0.00	\$1,585.63
940 BOX TOPS/TARGET	\$0.00	\$91.20	\$1,490.95	\$427.69	\$1,154.46	\$0.00	\$1,154.46
950 BAND - STUDENTS	\$0.00	\$303.00	\$5,504.09	\$3,596.00	\$2,211.09	\$0.00	\$2,211.09
960 STEM PROGRAM	\$0.00	\$0.00	\$1,748.03	\$0.00	\$1,748.03	\$0.00	\$1,748.03
980 YEARBOOK	\$0.00	\$2,748.32	\$2,012.18	\$1,339.12	\$3,421.38	\$0.00	\$3,421.38
988 ADMINISTRATION	\$0.00	\$12,770.26	\$4,354.30	\$7,796.55	\$9,328.01	\$0.00	\$9,328.01
990 LIBRARY	\$0.00	\$11,859.27	\$11,137.20	\$7,614.52	\$15,381.95	\$0.00	\$15,381.95
991 BUILDERS CLUB	\$0.00	\$1,089.50	\$3,940.22	\$904.46	\$4,125.26	\$0.00	\$4,125.26
992 LEADERSHIP	\$0.00	\$3,728.65	\$1,451.37	\$2,385.82	\$2,794.20	\$0.00	\$2,794.20
995 ART CLASS	\$0.00	\$0.00	\$265.86	\$0.00	\$265.86	\$0.00	\$265.86
<b>Total</b>	<b>\$0.00</b>	<b>\$100,288.83</b>	<b>\$64,669.43</b>	<b>\$90,645.97</b>	<b>\$74,312.29</b>	<b>\$0.00</b>	<b>\$74,312.29</b>

## Payment Register

**Options:** Year: 2020-2021, Fund: BOND FUND #36, Date Range: 6/30/2021 - 6/30/2021, Print Payroll Payments: False

Payment No	Date	Vendor No	Vendor	Type	Date Voided	Void Amount	Amount
1	06/30/2021	644	LWPB ARCHITECTS				\$105,141.25
2	06/30/2021	2046	STEPHEN H. MCDONALD AND AS				\$50,250.00
<b>Non-Payroll Total:</b>							<b>\$155,391.25</b>
<b>Payroll Total:</b>							<b>\$0.00</b>
<b>Balance Foward:</b>							<b>\$0.00</b>
<b>Total:</b>							<b>\$155,391.25</b>

# Superior Office Systems

1324 S FRETZ AVE #100  
EDMOND, OK 73003  
405-348-1118

## RENTAL AGREEMENT

**CUSTOMER:** Oakdale Schools  
**ATTN:** Marlene  
**ADDRESS:** 10901 N Sooner Road  
**CITY:** Edmond, OK 73013  
**PHONE:** 513-9070

**EQUIPMENT DESCRIPTION:** See Reverse  
**SERIAL NUMBER:** See Reverse  
**METER:** See Reverse

**TERM OF AGREEMENT:** 36 Months 7/1/21 to 6/30/24  
**MONTHLY RATE:** \$1595.00 tax exempt

**INCLUSIONS:** Equipment, parts, labor & supplies  
**EXCLUSIONS:** PC/Network Support & paper  
**CONDITIONS:** Pages billed monthly in arrears @ .008 B&W & 08 color.  
Customer is responsible for submitting meter counts the first of each month @ [www.okcopier.com](http://www.okcopier.com)

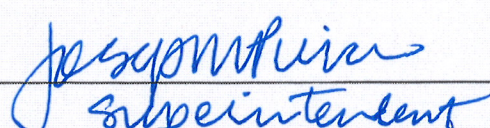
**CUSTOMER**  **DATE** 7/1/21  
**TITLE** Superintendent

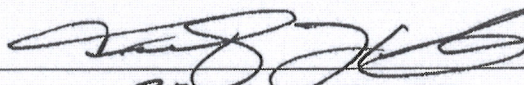
**SUPERIOR**  **DATE** 6/29/21  
**TITLE** PRESIDENT

\*RENTAL CONTRACT PROVIDES FOR REPLACEMENT OF UNIT DURING TERM OF CONTRACT WITH LIKE UNIT BASED ON MUTUAL AGREEMENT OF SUPERIOR AND THE CUSTOMER. CONTRACT IS UPGRADABLE BUT NON-CANCELLABLE FOR TERM OF THE AGREEMENT AND IS NON-ASSIGNABLE.



1 LANDSCAPE PLAN  
SCALE: 1"=30'

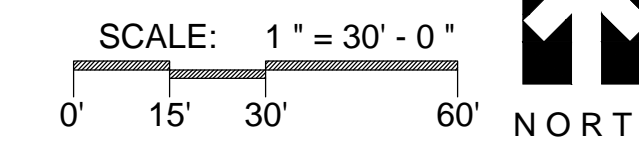

GENERAL NOTES:

- CONTRACTOR SHALL BE FAMILIAR WITH ALL EXISTING SITE CONDITIONS AND UNDERGROUND UTILITIES, PIPES, AND STRUCTURES. CONTRACTOR SHALL BE RESPONSIBLE FOR BODILY INJURY AND/OR ANY COST INCURRED DUE TO DAMAGE OF OWNER'S PROPERTY OR SAID UTILITIES. CONTRACTOR SHALL HAND DIG FOOTINGS, TREE WELLS, PLANTING BEDS, ETC. AS REQUIRED. CONTRACTOR IS RESPONSIBLE FOR CONTACTING UTILITY COMPANIES PRIOR TO ANY EXCAVATION.
- ANY CONFLICTING INFORMATION SHALL BE BROUGHT TO THE ATTENTION OF THE LANDSCAPE ARCHITECT OR THE LANDSCAPE ARCHITECT SHALL ASSUME THAT THE CONTRACTOR HAS INCORPORATED THE SPECIFIED ITEM.
- DO NOT WILLFULLY PROCEED WITH CONSTRUCTION OF DESIGN WHEN UNKNOWN OBSTRUCTIONS AND/OR GRADE DIFFERENCES EXIST THAT MAY NOT HAVE BEEN KNOWN DURING DESIGN. SUCH CONDITIONS SHALL BE IMMEDIATELY BROUGHT TO THE ATTENTION OF THE LANDSCAPE ARCHITECT. THE CONTRACTOR SHALL ASSUME FULL RESPONSIBILITY FOR ALL NECESSARY REVISIONS DUE TO FAILURE TO GIVE SUCH NOTIFICATION.
- CONTRACTOR SHALL NOTIFY LANDSCAPE ARCHITECT 48 HOURS PRIOR TO COMMENCEMENT OF WORK TO COORDINATE PROJECT INSPECTION SCHEDULES. CONTRACTOR SHALL FURNISH ALL LABOR, MATERIALS, EQUIPMENT, AND SERVICES NECESSARY TO PROVIDE ALL WORK. WORK TO BE COMPLETE IN PLACE AS SPECIFIED.
- ALL MATERIALS SHALL BE OF STANDARD, APPROVED AND FIRST GRADE QUALITY AND SHALL BE IN PRIME CONDITION WHEN INSTALLED AND ACCEPTED. ANY COMMERCIALY PROCESSED OR PACKAGED MATERIAL SHALL BE DELIVERED TO THE SITE IN THE ORIGINAL UNOPENED PACKAGING BEARING THE MANUFACTURER'S GUARANTEED ANALYSIS.
- PLANTS SHALL BE IN A MOIST, VIGOROUS CONDITION, FREE FROM DEAD WOOD, BRUISES OR OTHER ROOT OR BRANCH INJURIES. NO CONTAINER GROWN TREES OVER 2" CALIPER WILL BE ACCEPTED. THE LANDSCAPE ARCHITECT OR OWNER'S REPRESENTATIVE HAS THE RIGHT TO REJECT ANY PLANTS THAT HE/SHE FEELS DOES NOT MEET THE STANDARDS AS SET FORTH BY THE AMERICAN STANDARDS INSTITUTE (ANSI) PUBLICATIONS: Z60.1--LATEST EDITION. NO SUBSTITUTIONS SHALL BE ALLOWED WITHOUT APPROVAL OF THE LANDSCAPE ARCHITECT.
- QUANTITIES ON PLANT MATERIALS LIST ARE FOR CONVENIENCE ONLY. CONTRACTOR IS RESPONSIBLE FOR ALL PLANTS SHOWN ON PLANTING PLANS AND COVERAGE OF ALL AREAS DELINEATED. WHEN DISCREPANCIES OCCUR BETWEEN PLANT LIST AND PLANTING PLANS, THE PLANS ARE TO SUPERSEDE THE PLANT LIST IN ALL CASES.
- THE LOCATION OF PLANTS SHOWN ON THIS PLAN ARE APPROXIMATE. FIELD ADJUST PLANT LOCATIONS IF NECESSARY. VERIFY NEW LOCATION WITH LANDSCAPE ARCHITECT OR CITY REPRESENTATIVE, TYPICAL.
- MULCH ALL TREES AND PLANTING AREAS WITH 3" MINIMUM GRADE A SHREDDED CEDAR ALL BARK MULCH.
- IN ALL DISTURBED LAWN AREAS AND AS SHOWN, INSTALL U-3 BERMUDA SOD, CYNODON DACTYLON U-3.
- ALL LAWN AND PLANTING AREAS SHALL SLOPE TO DRAIN A MINIMUM OF 2% POSITIVE DRAINAGE UNLESS OTHERWISE NOTED. CONTRACTOR SHALL BE RESPONSIBLE AND BEAR COSTS OF RE-LANDSCAPING FOR GRADES.
- ALL ITEMS SHOWN ON THE PLANTING PLANS AND DETAILS SHALL BE INCLUDED IN THE COST OF THE PLANTING. THIS SHALL INCLUDE, BUT NOT BE LIMITED TO, TREE STAKING, FERTILIZING, EXCAVATION AND WATERING AS REQUIRED BY THE SPECIFICATIONS. ANY ITEM NOT LISTED ON THE BID SHEET SHALL BE CONSIDERED INCIDENTAL AND SHALL BE INCLUDED IN THE COST OF OTHER ITEMS.
- REFER TO SHEET LA-04 AND LA-05 FOR DETAILS/INSTRUCTIONS.

INSPECTION NOTES:

- CONTRACTOR SHALL BE RESPONSIBLE FOR NOTIFYING LANDSCAPE ARCHITECT FOR INSPECTION OF LANDSCAPING AT THE FOLLOWING TIMES:
  - VISIT ONE
    - DELIVERY OF TREES, SHRUBS AND GROUND COVER.
    - LAYOUT OF TREE AND BED LOCATIONS AND EXCAVATION OF TREE PLANTING PITS
    - STAKING OF ANY CONCRETE EDGING OR HARDSCAPE
  - VISIT TWO
    - COMPLETION OF PLANTING, PRIOR TO APPLICATION OF MULCH MATERIALS.
- CONTRACTOR SHALL NOTIFY LANDSCAPE ARCHITECT 48 HOURS PRIOR TO COMMENCEMENT OF WORK TO COORDINATE PROJECT INSPECTION SCHEDULES. LACK OF NOTICE, OR PROCEEDING WITH PLANTING WITHOUT INSPECTION MAY REQUIRE CONTRACTOR TO DIG UP TO REVEAL PLANTING PITS.
- PROVIDE THE LANDSCAPE ARCHITECT COPIES OF DELIVERY SHEETS SHOWING GENUS, SPECIES AND CULTIVAR NAMES AND QUANTITIES OF PLANTS DELIVERED OR PURCHASED.
- PROVIDE THE LANDSCAPE ARCHITECT COPIES OF TICKETS SHOWING PURCHASE OF TOPSOIL, MYCORRHIZAL FUNGI, MULCH, FERTILIZER AND OTHER PLANTING PRODUCTS.

QUANTITY	COMMON NAME	BOTANICAL NAME	SIZE	ROOTBALL	SPACING	REMARKS
17	OKLAHOMA REDBUD	CERCIS CANADENSIS 'OKLAHOMA'	2.5" CAL	B&B	AS SHOWN	
7	AMERICAN SYCAMORE	PLATANUS OCCIDENTALIS	3" CAL	B&B	AS SHOWN	
15	SHUMARD OAK	QUERCUS SHUMARDII	3" CAL	B&B	AS SHOWN	
3	ESCARPMENT LIVE OAK	QUERCUS VIRGINIANA ESCARPMENT	3" CAL	B&B	AS SHOWN	
14	CEDAR ELM	ULMUS CRASSIFOLIA	3" CAL	B&B	AS SHOWN	
<b>EVERGREEN TREES</b>						
8	ARIZONA CYPRESS	CUPRESSUS ARIZONICA	5-6' H	B&B	AS SHOWN	UNSHAURED
3	LOBLOLLY PINE	PINUS TAEDA	9-10' H	B&B	AS SHOWN	



5909 NW Expressway, Ste 600  
Oklahoma City, Oklahoma 73132  
Telephone: 406-722-7270  
Facsimile: 406-722-0374  
www.lwpb.com

NOT FOR  
CONSTRUCTION  
SCHEMATIC  
DESIGN

OAKDALE PUBLIC SCHOOLS  
OAKDALE 2021 INFRASTRUCTURE PROJECTS  
10901 N. SOONER RD, EDMOND, OK 73013

JOB NO: 20-1457-E883  
DATE: Issue Date

REVISIONS

3" CAL

DRAWING TITLE  
OVERALL SITE PLAN

LA-01



THE CONTRACTOR SHALL BE RESPONSIBLE FOR THE SAFETY OF ALL UTILITIES, PUBLIC OR PRIVATE, DURING CONSTRUCTION AND WILL SATISFY HIMSELF AS TO THEIR ACTUAL LOCATION PRIOR TO CONSTRUCTION. HE WILL NOTIFY THE UTILITY OWNERS OF ACTUAL TIMES OF CONSTRUCTION TO ALLOW THEIR PARTICIPATION.



825 N. Broadway, Suite 315  
Oklahoma City, OK 73102  
406-628-2200  
www.LandscapeArchitects.com

LOCAL FILE: 7/1/2021 12:05:27 PM  
CONTR. FILE: 20-1457-E883  
PLOT DATE: LWPB JOB  
MEMO: LWPB 2019.0002

OAKDALE PUBLIC SCHOOLS  
OAKDALE 2021 INFRASTRUCTURE PROJECTS  
10901 N. SOONER RD, EDMOND, OK 73013

JOB NO: 20-1457-E883  
DATE: Issue Date

REVISIONS

DRAWING TITLE  
HARDSCAPE PLAN

LA-02



1 HARDSCAPE AND DRAINAGE PLAN  
SCALE: 1"=10'

SCALE: 1" = 10' - 0"  
0' 5' 10' 20'



THE CONTRACTOR SHALL BE RESPONSIBLE FOR THE SAFETY OF ALL UTILITIES, PUBLIC OR PRIVATE, DURING CONSTRUCTION AND WILL SATISFY HIMSELF AS TO THEIR ACTUAL LOCATION PRIOR TO CONSTRUCTION. HE WILL NOTIFY THE UTILITY OWNERS OF ACTUAL TIMES OF CONSTRUCTION TO ALLOW THEIR PARTICIPATION.



LOCAL FILE: 7/1/2021 12:05:27 PM  
CADD FILE: 20-1457-E883  
PLOT DATE: LWPB JOB  
TEMPLATE: LWPB 2019.0002



**1 TREE PROTECTION - ORANGE VINYL**

NOTES:

- TREE PROTECTION ZONE REQUIRED AS SHOWN ON PLANS AND WHERE CONSTRUCTION OPERATIONS MUST TAKE PLACE WITHIN 30' OF EXISTING TREES NOTED TO BE PROTECTED.
- MAINTAIN BARRIER AT ALL TIMES.
- SECURELY ATTACH ORANGE VINYL CONSTRUCTION FENCING.
- REMOVE POSTS AND FENCING AT COMPLETION OF THE PROJECT OR WHEN DIRECTED BY THE OWNER.

**2 POURED IN PLACE SURFACING - DURAPLAY**

NOTES:

- POURED IN PLACE SURFACING SHALL BE DURAPLAY SURFACING SYSTEM, BY DURAPLAY OR APPROVED EQUAL. WWW.DURAPLAY.COM
- TOTAL THICKNESS OF THE SURFACING SYSTEM IS BASED UPON MAXIMUM FALL HEIGHT OF PLAY EQUIPMENT.
- MATCH TOP OF CURB TO HEIGHT OF ADJACENT CURBING/PAVEMENT, OR AS NOTED ON PLAN.

**3 ARTIFICIAL TURF PLAYGROUND SURFACING**

NOTES:

- ARTIFICIAL TURF PLAYGROUND SURFACING TO BE PLAYGROUND GRASS BY FOREVERLAWN OR APPROVED EQUAL. WWW.FOREVERLAWN.COM
- INSTALL PER MANUFACTURER'S RECOMMENDATIONS.
- TOTAL THICKNESS OF THE PLAYGROUND GRASS SURFACING SYSTEM IS BASED UPON MAXIMUM FALL HEIGHT OF PLAY EQUIPMENT.
- MATCH TOP OF CURB TO HEIGHT OF ADJACENT CURBING/PAVEMENT.
- SUBMIT COLOR SAMPLES FOR APPROVAL PRIOR TO ORDERING.

**4 ARTIFICIAL TURF WITH GRAVEL BASE**

NOTES:

- ARTIFICIAL TURF TO BE BY FOREVERLAWN OR APPROVED EQUAL.
- WWW.FOREVERLAWN.COM
- SUBMIT COLOR SAMPLES FOR APPROVAL PRIOR TO ORDERING.
- INSTALL PER MANUFACTURER'S RECOMMENDATIONS.

**5 CONCRETE PLAYGROUND BORDER**

NOTE:

- MATCH TOP OF CURB TO HEIGHT OF ADJACENT CURBING/PAVEMENT, OR AS NOTED ON PLAN.

**6 ARTIFICIAL TURF PLAY MOUND**

NOTES:

- PLAYMOUNDS TO BE BY FOREVERLAWN OR APPROVED EQUAL. WWW.FOREVERLAWN.COM
- SIZES ARE AS FOLLOWS:  
TYPE A = 10' DIA. X 36\"/>

**7 POST OR UPRIGHT SECTION**

**8 MOUNTAINEERING ROPE CLIMBER**

NOTES:

- MOUNTAINEERING ROPE CLIMBER TO BE MODEL COR10545 BY KOMPAN OR APPROVED EQUAL. (WWW.KOMPAN.COM)
- REFER TO PLAN FOR LOCATION.

**9 PLAYGROUND SPHERES**

NOTES:

- PLAYGROUND SPHERES TO BE BY GORIC OR APPROVED EQUAL. (WWW.GORIC.COM, 1-877-467-4287)
- REFER TO PLAN FOR SIZES AND COLORS
- INSTALL PER MANUFACTURER'S RECOMMENDATIONS

**10 PICKLEBALL NET AND SLEEVE SYSTEM**

NOTES:

- PICKLEBALL NET SYSTEM TO BE BY ATHLETIC CONNECTION, LLC OR APPROVED EQUAL. WWW.ATHLETICCONNECTION.COM
- SUBMIT PRODUCT INFORMATION FOR APPROVAL PRIOR TO ORDERING
- COLOR OF POSTS TO BE BLACK

**11 MULTIPURPOSE COURT**

**12 SEGMENTAL SEAT WALL**

BLOCK WALL NOTES:

- SUBMIT COLOR FOR APPROVAL PRIOR TO ORDERING.
- ALTERNATE COURSES A AND B UNTIL DESIRED COLUMN HEIGHT IS REACHED.
- WALL UNIT PATTERN MAY VARY

**13 SEGMENTAL RETAINING WALL**

NOTE:

- STONE TO BE DIAMOND BLOCK PRO RETAINING WALL SYSTEM STRAIGHT FACE BY ANCHOR WALL SYSTEMS, OR EQUAL.
- COLOR TO BE APPROVED BY OWNER.
- HEIGHT OF WALL VARIES, SEE PLAN.

**14 SEGMENTAL SEATWALL AT PLAYGROUND**

NOTE:

- STONE TO BE DIAMOND BLOCK PRO RETAINING WALL SYSTEM STRAIGHT FACE BY ANCHOR WALL SYSTEMS, OR EQUAL.
- COLOR TO BE APPROVED BY OWNER.
- HEIGHT OF WALL VARIES, SEE PLAN.

**15 FRENCH DRAIN**

NOTE:

- DRAINAGE PIPE TO HAVE A MINIMUM SLOPE OF 1% DOWN STREAM

**16 4\"/>**

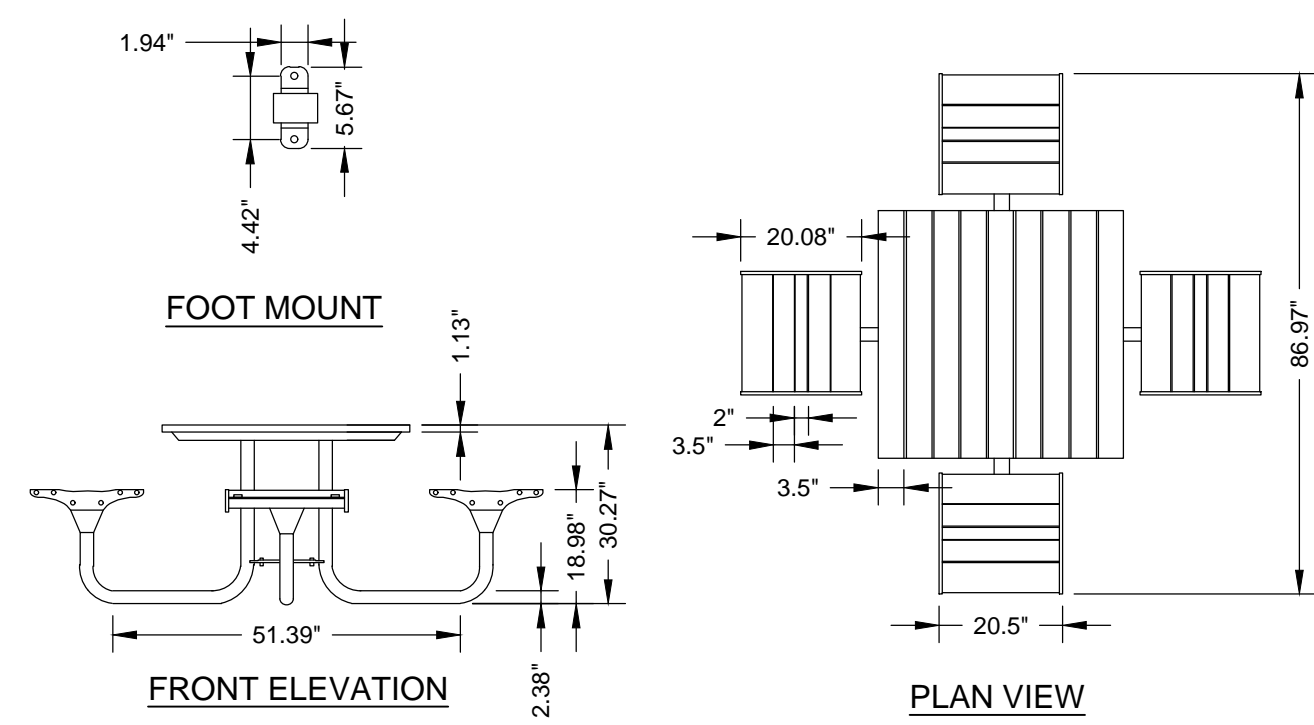

- NOTES:
1. TABLE TO BE BEACON HILL MODEL BH1841R-GT BY ANOVA SITE FURNISHINGS OR APPROVED EQUAL... WWW.ANOVAFURNISHINGS.COM
  2. CONTACT CHRISTOPHER TORRES (816)-602-4486
  3. INCLUDE SURFACE MOUNT.
  4. INCLUDE RECYCLED PLASTIC PLANKS.
  5. SUBMIT COLOR SAMPLES FOR APPROVAL PRIOR TO ORDERING.
  6. IF ACCESSIBLE TABLE IS SHOWN ON PLAN USE MODEL NUMBER BH1831R-GT

1 42" SQUARE TABLE - ANOVA

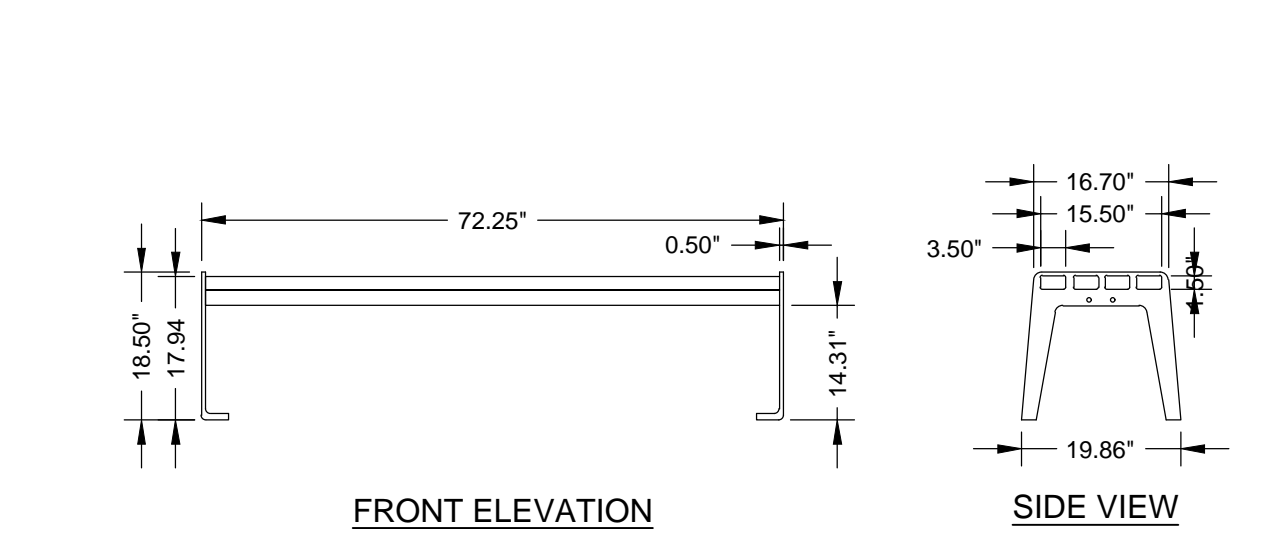

- NOTES:
1. BENCH WITHOUT BACK TO BE MADISON 6' CONTOUR BENCH BY ANOVA SITE FURNISHINGS OR APPROVED EQUAL... WWW.ANOVAFURNISHINGS.COM
  2. CONTACT CHRISTOPHER TORRES (816)-602-4486
  3. INCLUDE SURFACE MOUNT.
  4. INCLUDE RECYCLED PLASTIC PLANKS.
  5. SUBMIT COLOR SAMPLES FOR APPROVAL PRIOR TO ORDERING.

2 6' BENCH WITH OUT BACK - ANOVA

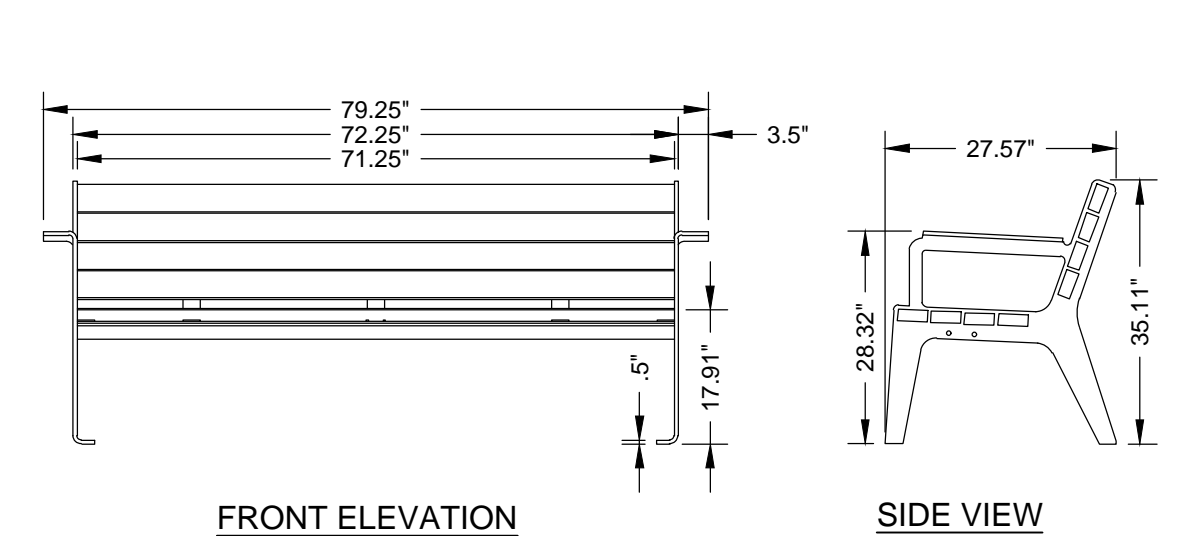

- NOTES:
1. BENCH WITH BACK TO BE MADISON 6' CONTOUR BENCH BY ANOVA SITE FURNISHINGS OR APPROVED EQUAL... WWW.ANOVAFURNISHINGS.COM
  2. CONTACT CHRISTOPHER TORRES (816)-602-4486
  3. INCLUDE SURFACE MOUNT.
  4. INCLUDE RECYCLED PLASTIC PLANKS.
  5. SUBMIT COLOR SAMPLES FOR APPROVAL PRIOR TO ORDERING.

3 6' BENCH - ANOVA

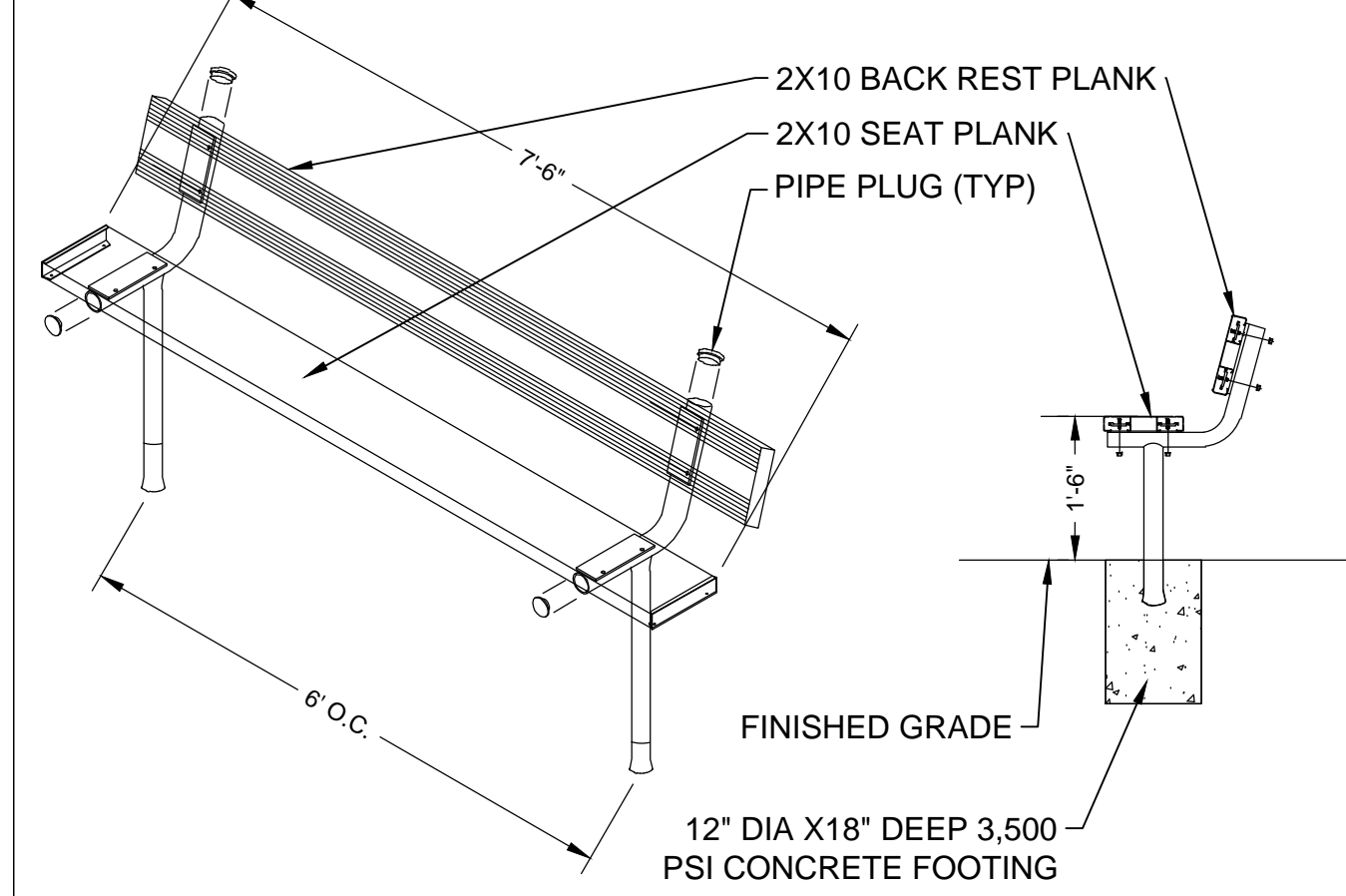

- NOTE:
1. ALUMINUM PLAYER BENCHES WITH BACKRESTS (MODEL AB75WB-I), BY BELSON OUTDOORS OR APPROVED EQUAL (WWW.BELSON.COM)
  2. INCLUDE INGROUND MOUNT
  3. INSTALL PER MANUFACTURER'S RECOMMENDATIONS

4 7'-6" ALUMINUM BENCH - BELSON

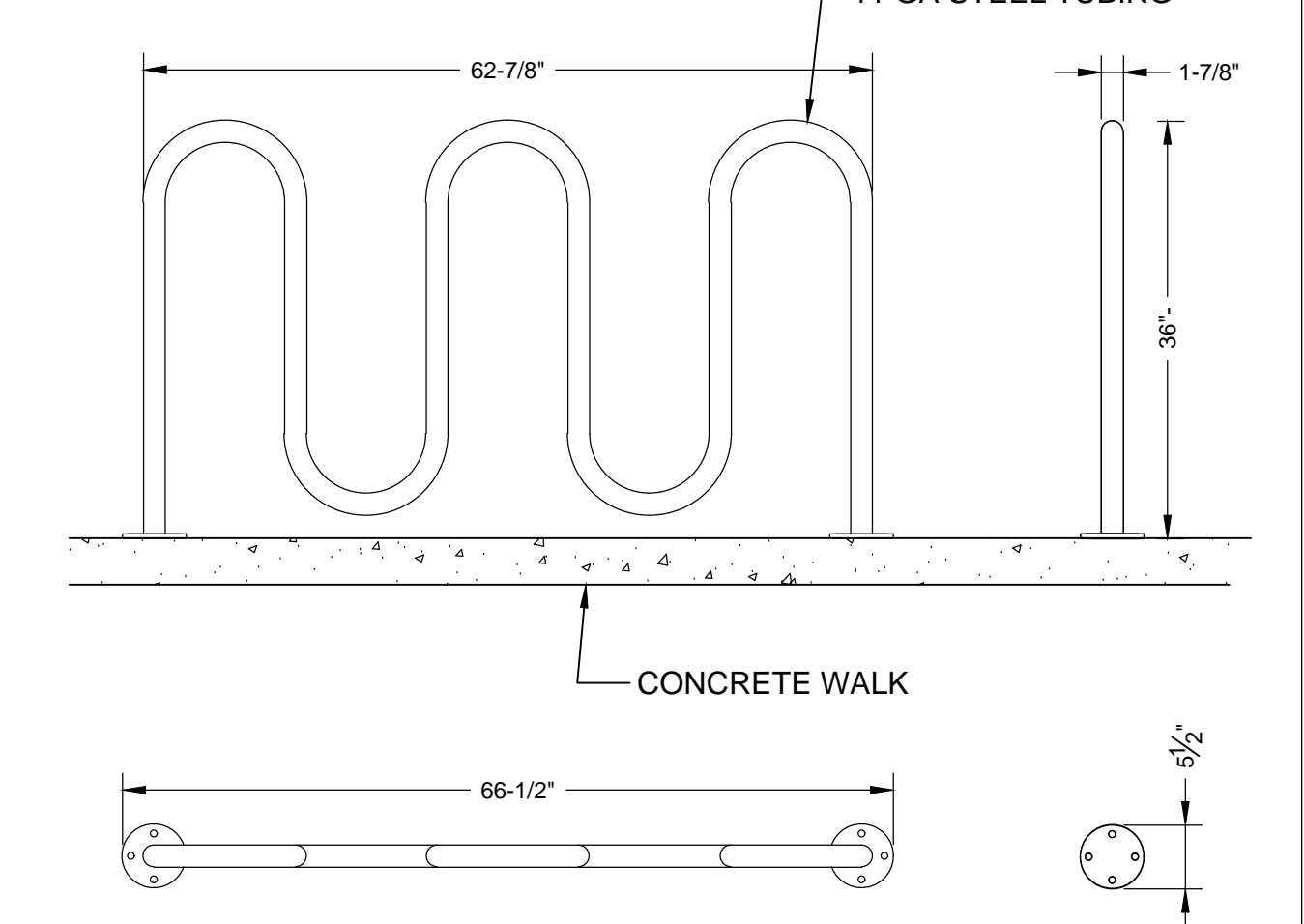

- NOTE:
1. BIKE RACK SHALL BE STAINLESS STEEL 7 WAVE RACK, MODEL # CBBR-9UR-SS BY BELSON OUTDOORS... WWW.BELSON.COM, OR EQUAL.
  2. INSTALL PER MANUFACTURER'S RECOMMENDATIONS.

5 BIKE RACK - 7 SPACE - BELSON

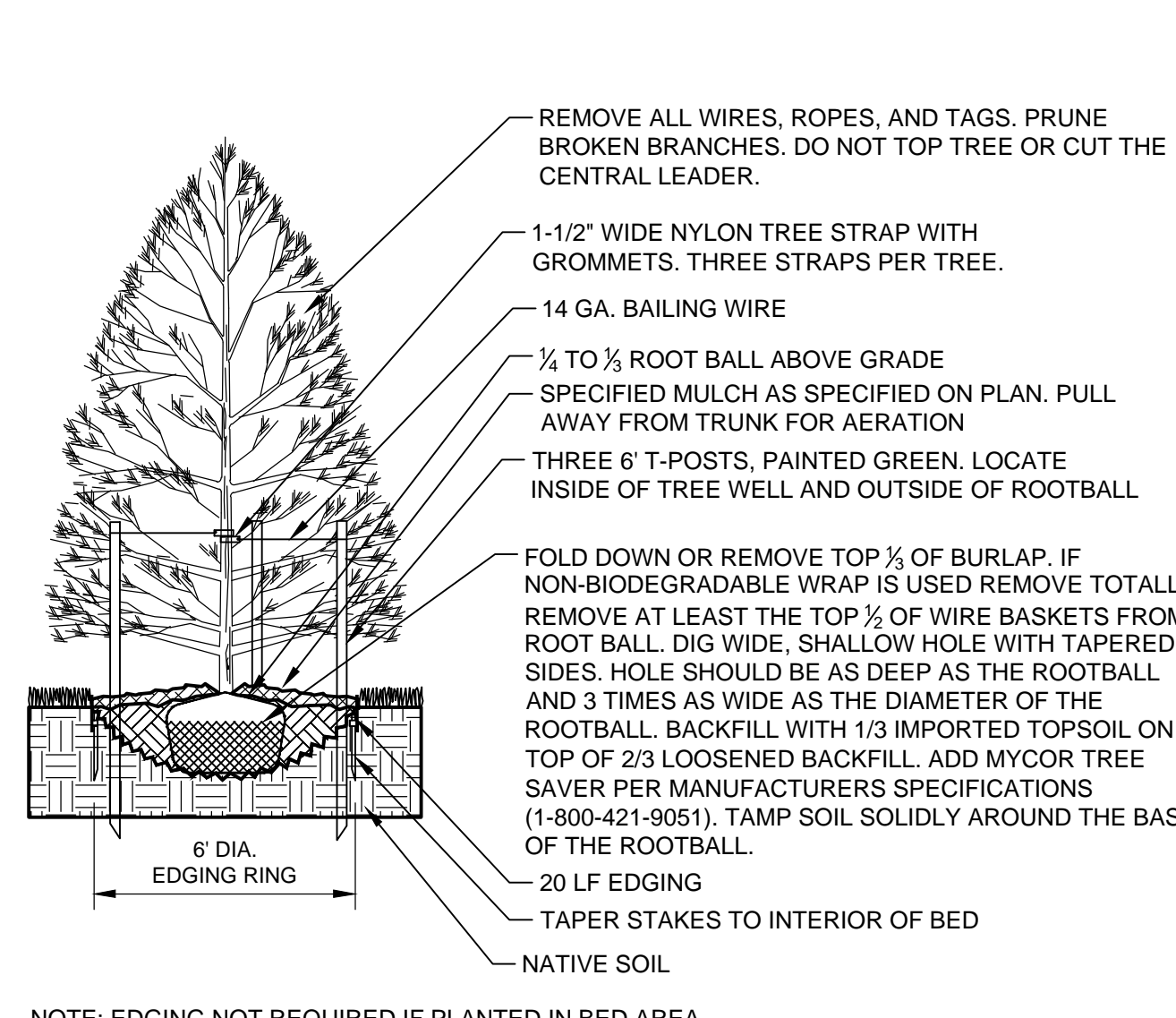

- NOTE: EDGING NOT REQUIRED IF PLANTED IN BED AREA

6 TREE PLANTING

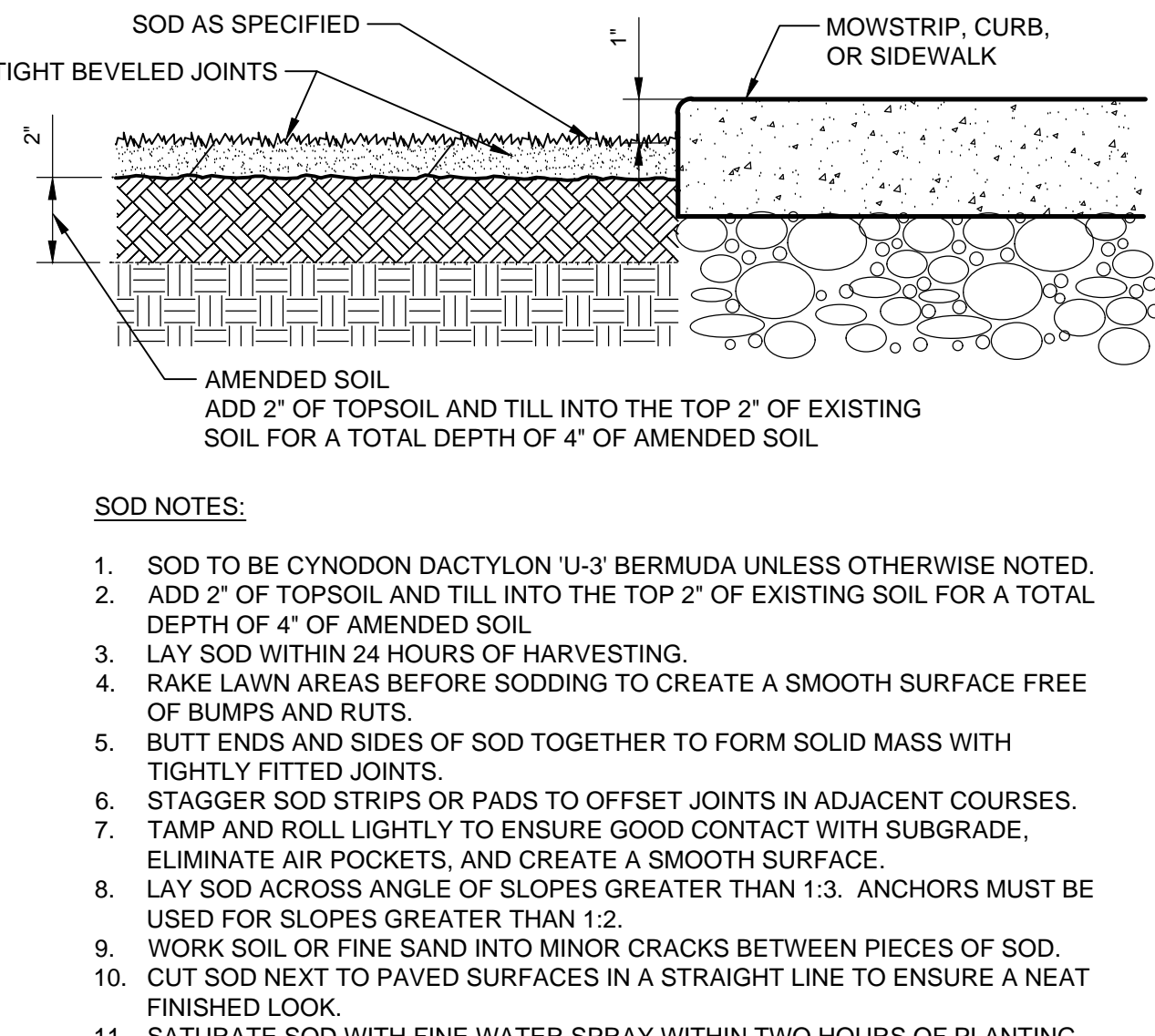

- SOD NOTES:
1. SOD TO BE CYNODON DACTYLON 'U-3' BERMUDA UNLESS OTHERWISE NOTED.
  2. ADD 2" OF TOPSOIL AND TILL INTO THE TOP 2" OF EXISTING SOIL FOR A TOTAL DEPTH OF 4" OF AMENDED SOIL.
  3. LAY SOD WITHIN 24 HOURS OF HARVESTING.
  4. RAKE LAWN AREAS BEFORE SODDING TO CREATE A SMOOTH SURFACE FREE OF BUMPS AND RUTS.
  5. BUTT ENDS AND SIDES OF SOD TOGETHER TO FORM SOLID MASS WITH TIGHTLY FITTED JOINTS.
  6. STAGGER SOD STRIPS OR PADS TO OFFSET JOINTS IN ADJACENT COURSES.
  7. TAMP AND ROLL LIGHTLY TO ENSURE GOOD CONTACT WITH SUBGRADE. ELIMINATE AIR POCKETS, AND CREATE A SMOOTH SURFACE.
  8. LAY SOD ACROSS ANGLE OF SLOPES GREATER THAN 1:3. ANCHORS MUST BE USED FOR SLOPES GREATER THAN 1:2.
  9. WORK SOIL OR FINE SAND INTO MINOR CRACKS BETWEEN PIECES OF SOD.
  10. CUT SOD NEXT TO PAVED SURFACES IN A STRAIGHT LINE TO ENSURE A NEAT FINISHED LOOK.
  11. SATURATE SOD WITH FINE WATER SPRAY WITHIN TWO HOURS OF PLANTING.

7 SOD INSTALLATION

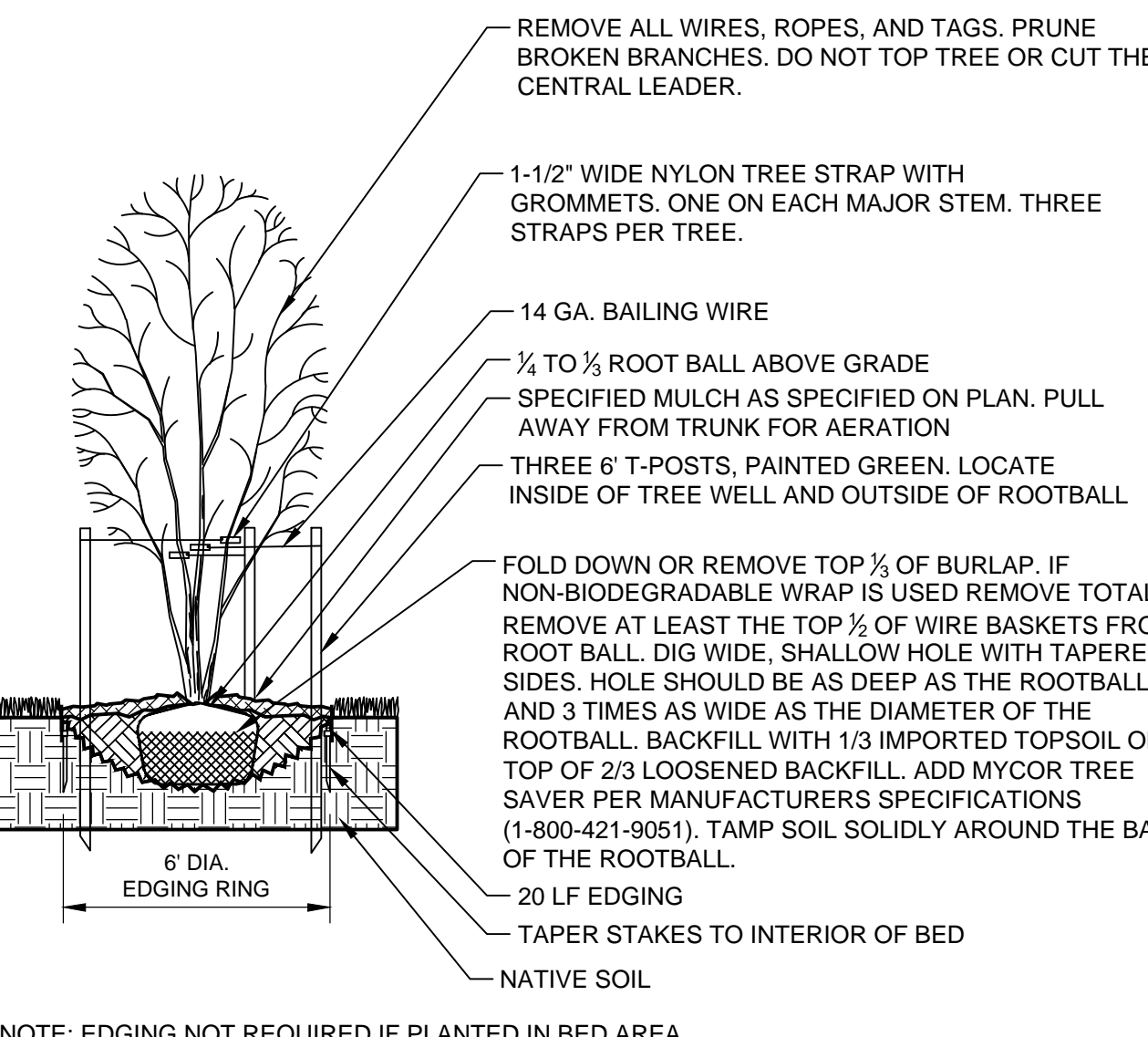

- NOTE: EDGING NOT REQUIRED IF PLANTED IN BED AREA

8 MULTI-STEM TREE PLANTING

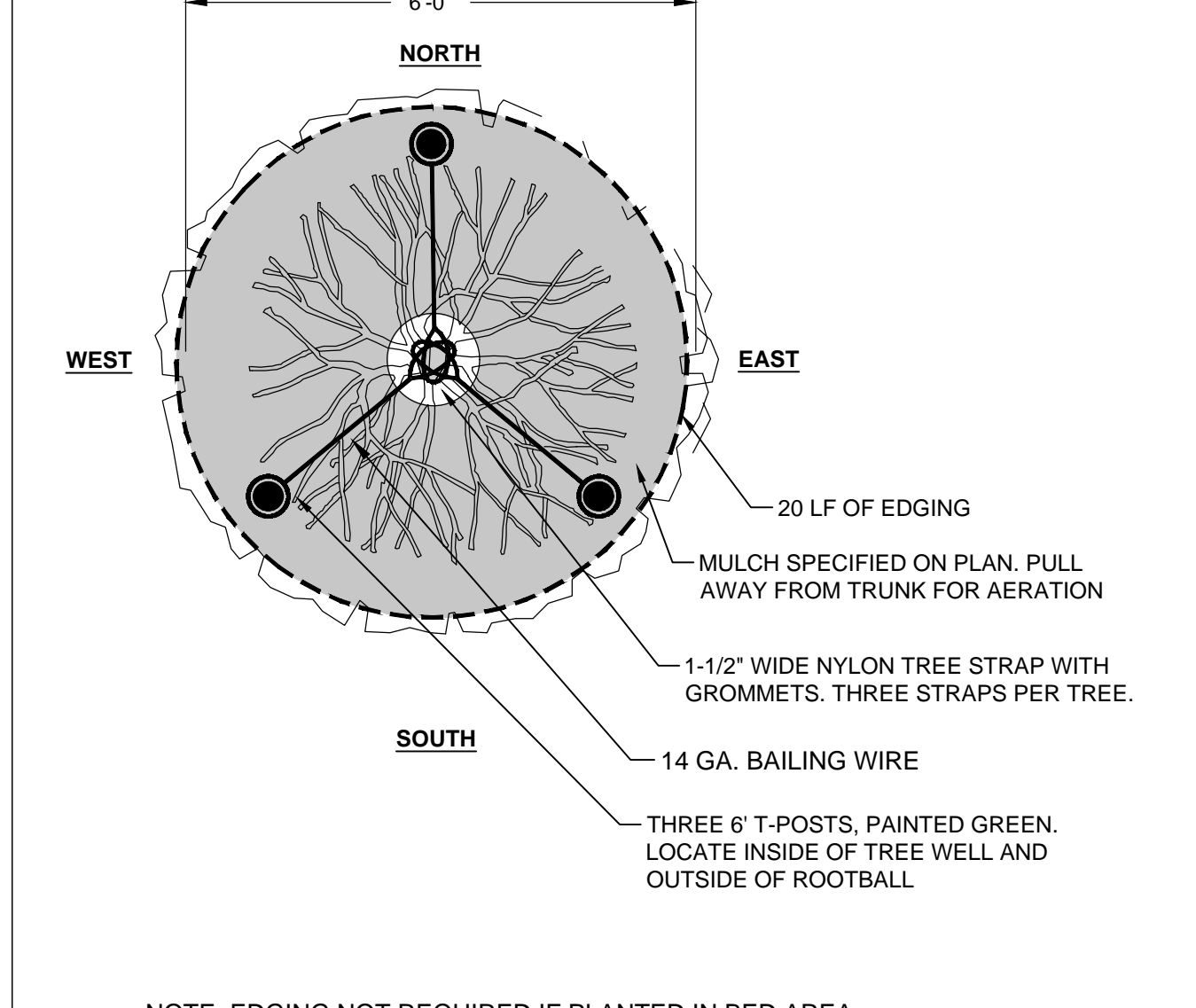

- NOTE: EDGING NOT REQUIRED IF PLANTED IN BED AREA

9 TREE STAKING

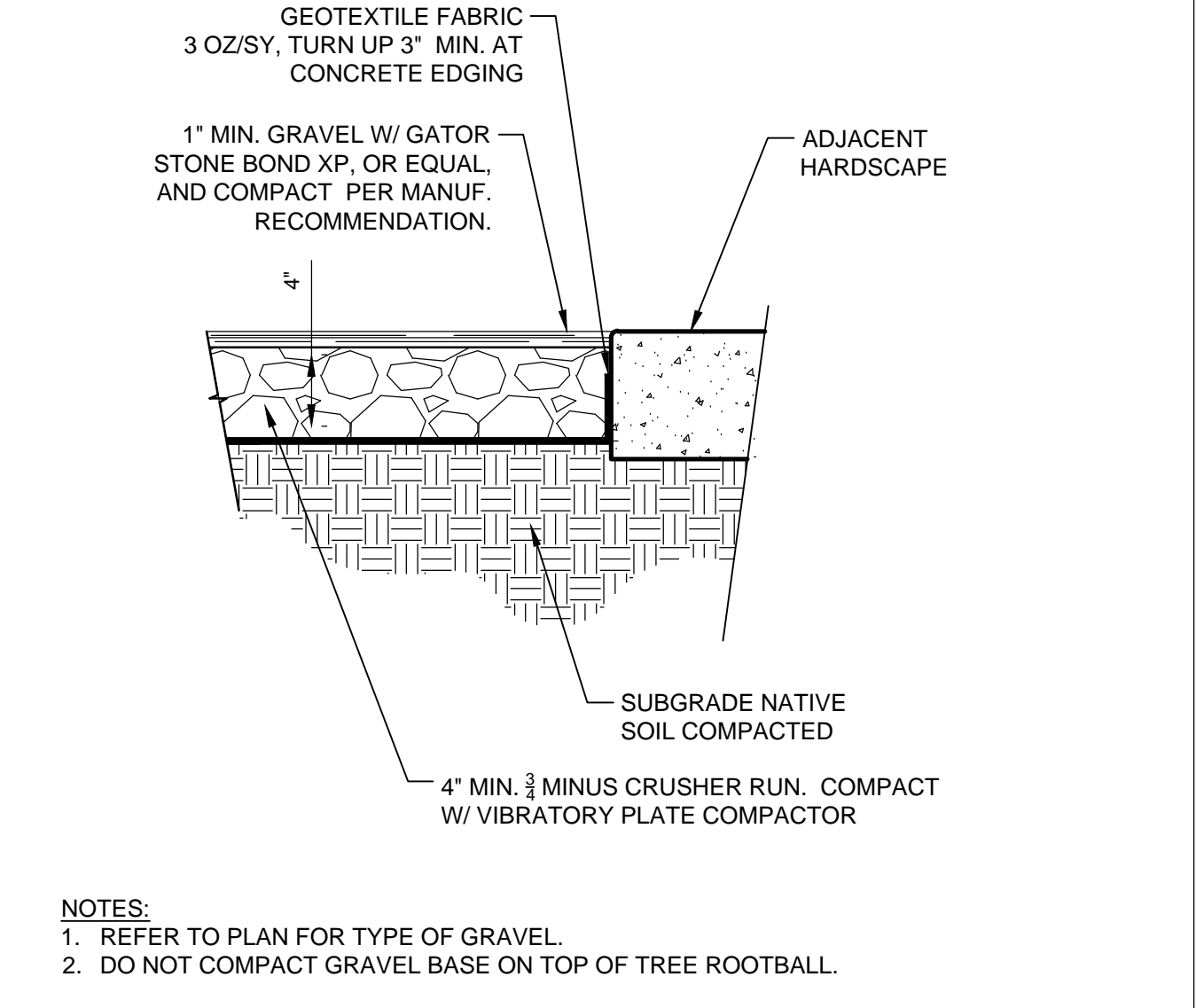

- NOTES:
1. REFER TO PLAN FOR TYPE OF GRAVEL.
  2. DO NOT COMPACT GRAVEL BASE ON TOP OF TREE ROOTBALL.

10 STABILIZED GRAVEL AT TREE - GATOR BOND

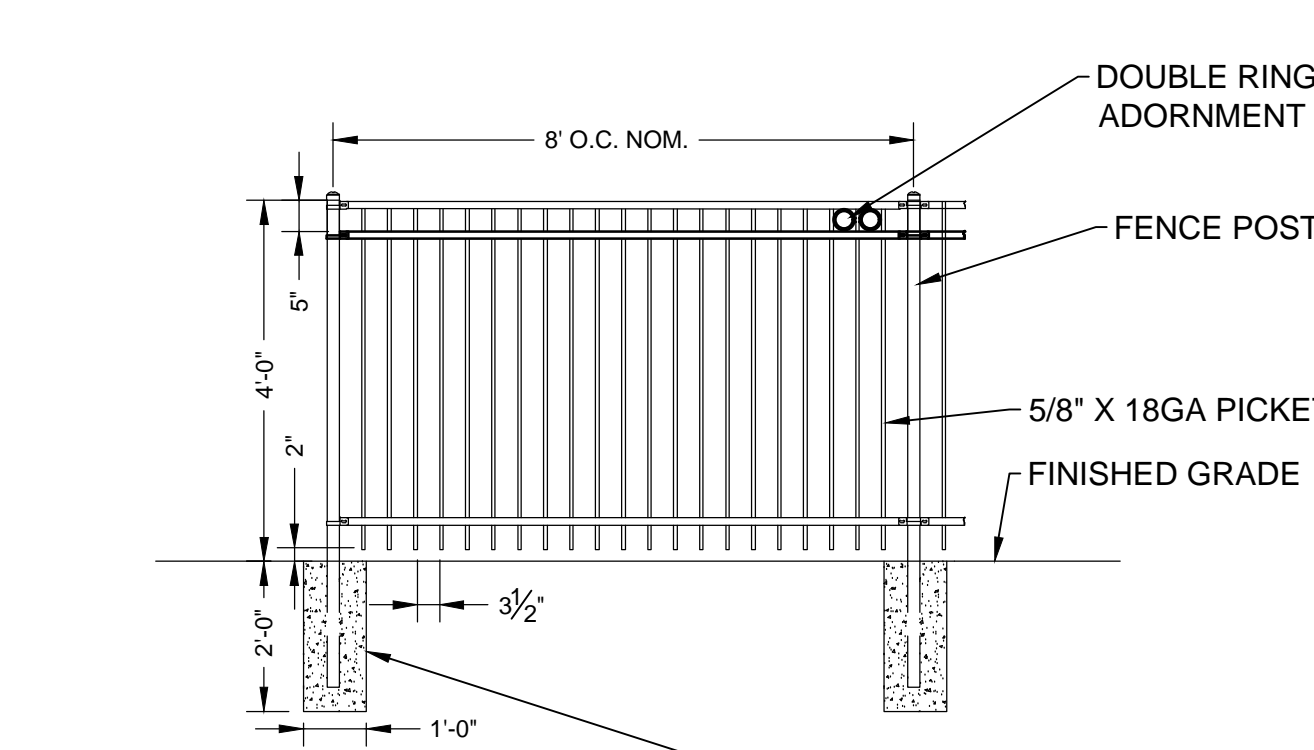

- NOTES:
1. 4' TALL FENCE AND GATE TO BE MONTAGE PLUS FENCE WITH MAJESTIC TOP BY AMERISTAR FENCE OR APPROVED EQUAL... WWW.AMERISTARFENCE.COM
  2. CONTACT MISTY SINGLETON (405)800-321-8724
  - 2.2. WWW.AMERISTARFENCE.COM
  3. INSTALL PER MANUFACTURER'S RECOMMENDATIONS.
  4. COLOR TO BE BLACK
  5. SUBMIT SHOP DRAWINGS FOR APPROVAL PRIOR TO ORDERING.

11 4' TALL DECORATIVE FENCE



- NOTES:
1. SOCCER GOAL TO BE 6' X 18' DELUXE PRO SOCCER GOAL BY FOLD-A-GOAL OR APPROVED EQUAL... WWW.FOLD-A-GOAL.COM
  2. INCLUDE 4MM WHITE NET AND PERMANENT SWIVEL WHEELS
  3. GOAL TO HAVE 4" ROUND WHITE ALUMINUM UPRIGHTS, CROSSBAR & BACK BOTTOM BARS W/CLIP CHANNELS
  4. WHITE ENAMEL FINISH
  5. 2" SQUARE ALUMINUM BACK SUPPORTS

12 SOCCER GOAL

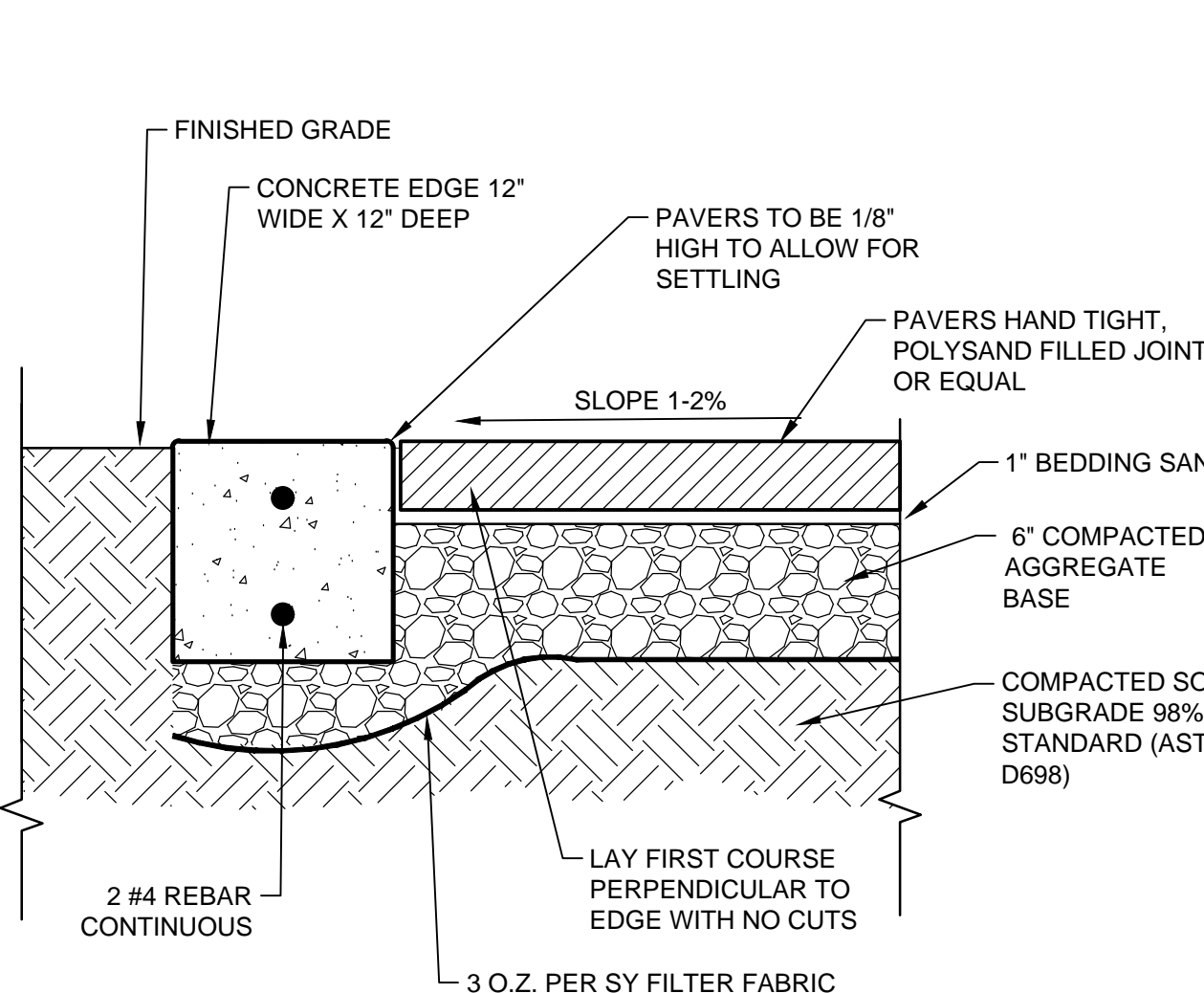

- NOTE:
1. PAVERS TO BE BY BELGARD OR APPROVED EQUAL... WWW.BELGARDCOMMERCIAL.COM
  2. SUBMIT COLOR FOR APPROVAL PRIOR TO ORDERING

13 PAVERS ON GRAVEL BASE

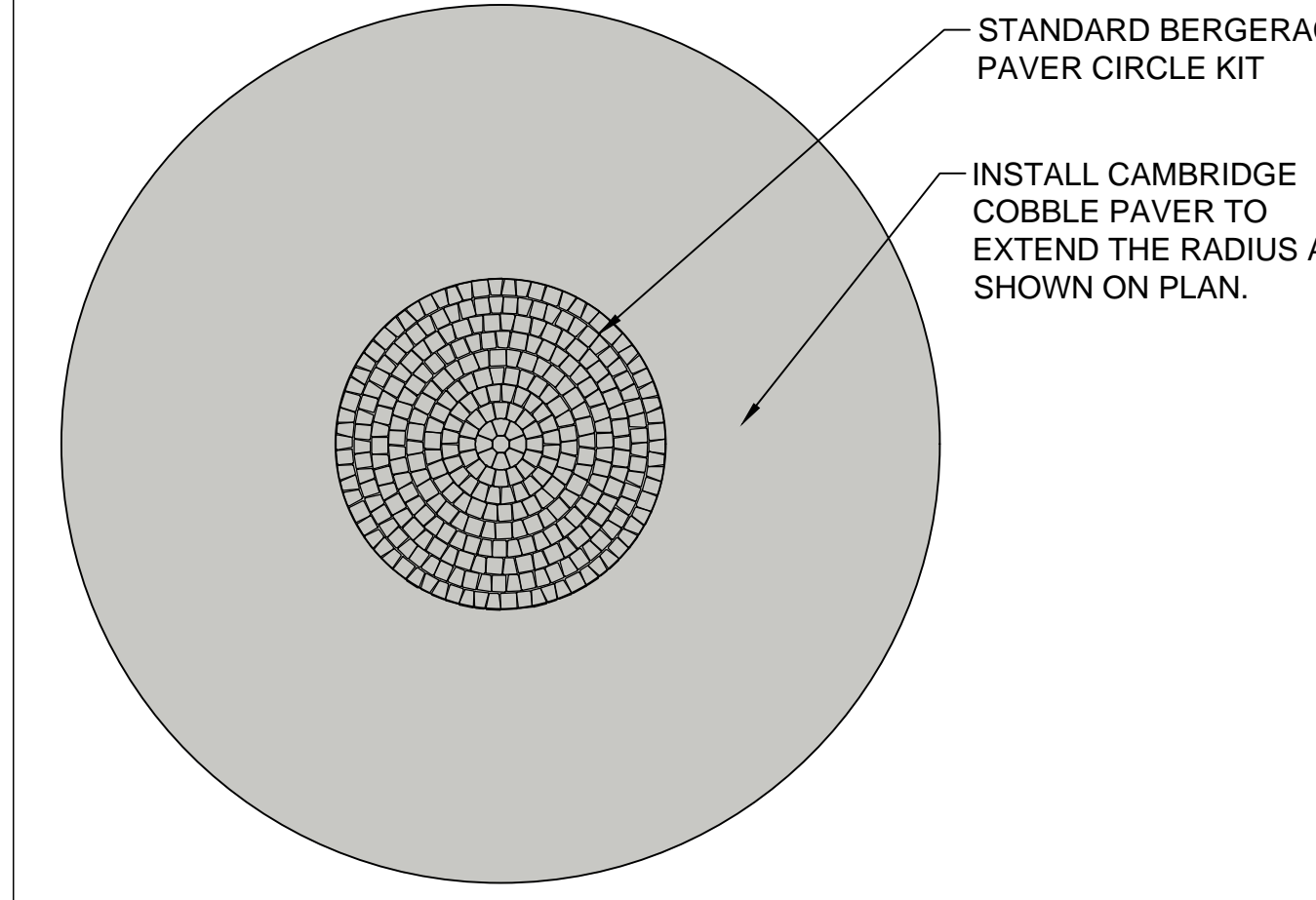

- NOTE:
1. PAVERS TO BE BY BELGARD OR APPROVED EQUAL... WWW.BELGARDCOMMERCIAL.COM
  2. SUBMIT COLOR FOR APPROVAL PRIOR TO ORDERING

14 PAVER PATTERN - BERGERAC

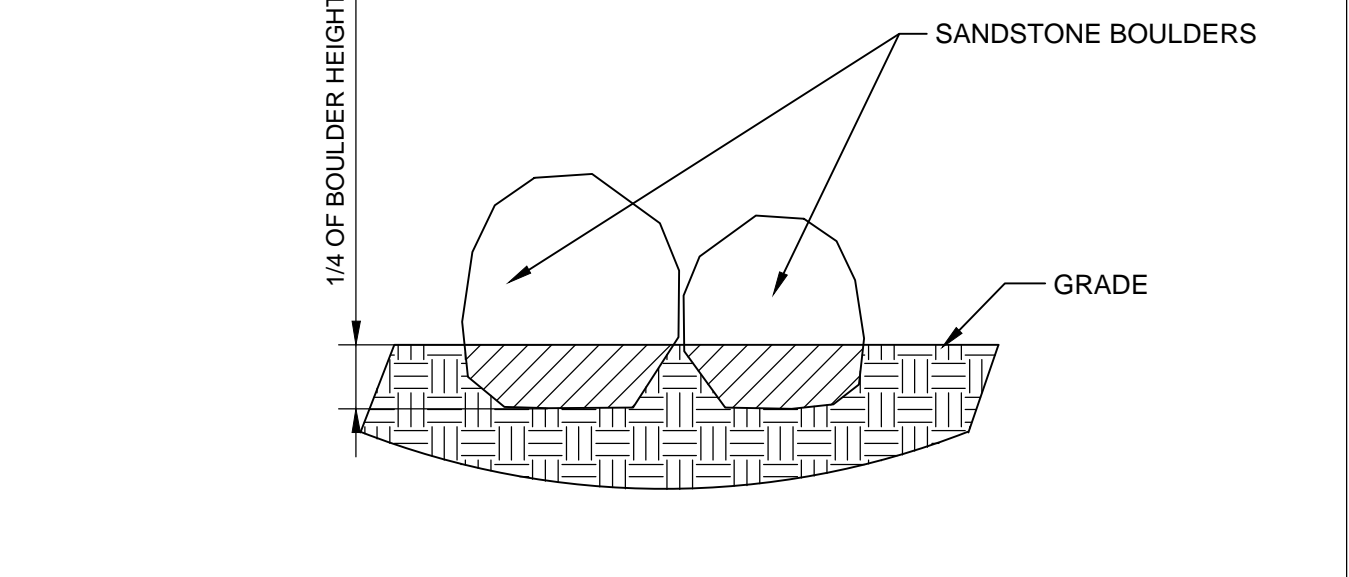

- NOTES:
1. BOULDERS SHALL BE SANDSTONE BOULDERS BY MINICK MATERIALS OR APPROVED EQUAL... WWW.MINICKMATERIALS.COM SIZES AS NOTED.
  2. BOULDERS SHALL NOT BE DUMPED OR DOZED INTO PLACE, BUT SET IN PLACE BY HAND OR MECHANICAL SLING.
  3. CONTRACTOR SHALL TAKE EXTREME CARE NOT TO SCRAPE, GOUGE OR OTHERWISE HARM THE EXPOSED FACE OF THE STONE.
  4. BOULDERS SHALL BE PLACED INTO SOIL SO THAT THE TOP AND MOST OF THE SIDES ARE SHOWING.
  5. PLACE STONES TO CREATE A 'NATURAL' EFFECT WITH THE MOST ATTRACTIVE SIDE FACING OUT.
  6. SUBMIT SAMPLES OR PHOTOGRAPHS FOR APPROVAL PRIOR TO DELIVERY.

15 BOULDER INSTALLATION

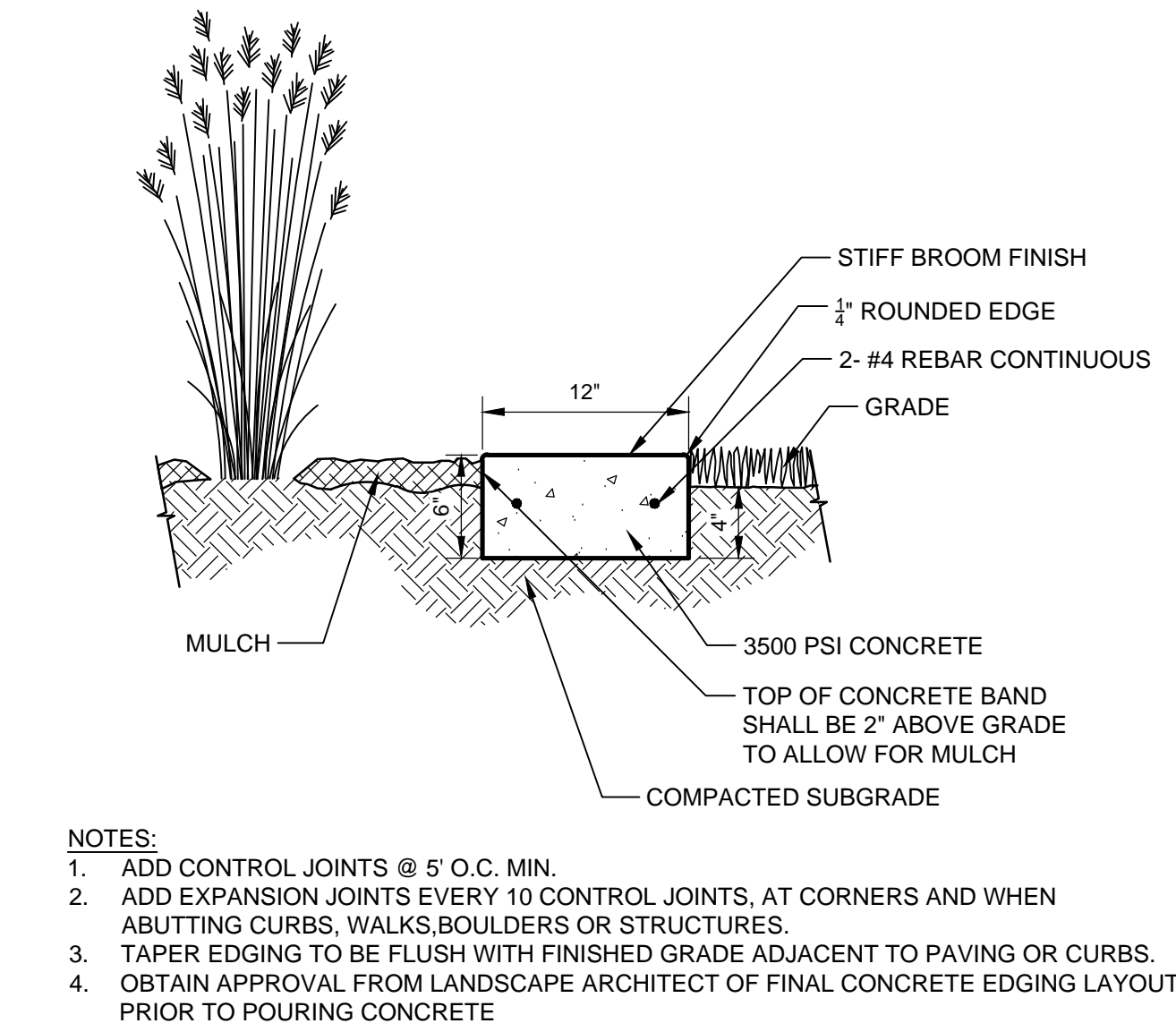

- NOTES:
1. ADD CONTROL JOINTS @ 5' O.C. MIN.
  2. ADD EXPANSION JOINTS EVERY 10 CONTROL JOINTS, AT CORNERS AND WHEN ABUTTING CURBS, WALKS, BOULDERS OR STRUCTURES.
  3. TAPER EDGING TO BE FLUSH WITH FINISHED GRADE ADJACENT TO PAVING OR CURBS.
  4. OBTAIN APPROVAL FROM LANDSCAPE ARCHITECT OF FINAL CONCRETE EDGING LAYOUT PRIOR TO POURING CONCRETE

16 CONCRETE EDGING 6"X12"

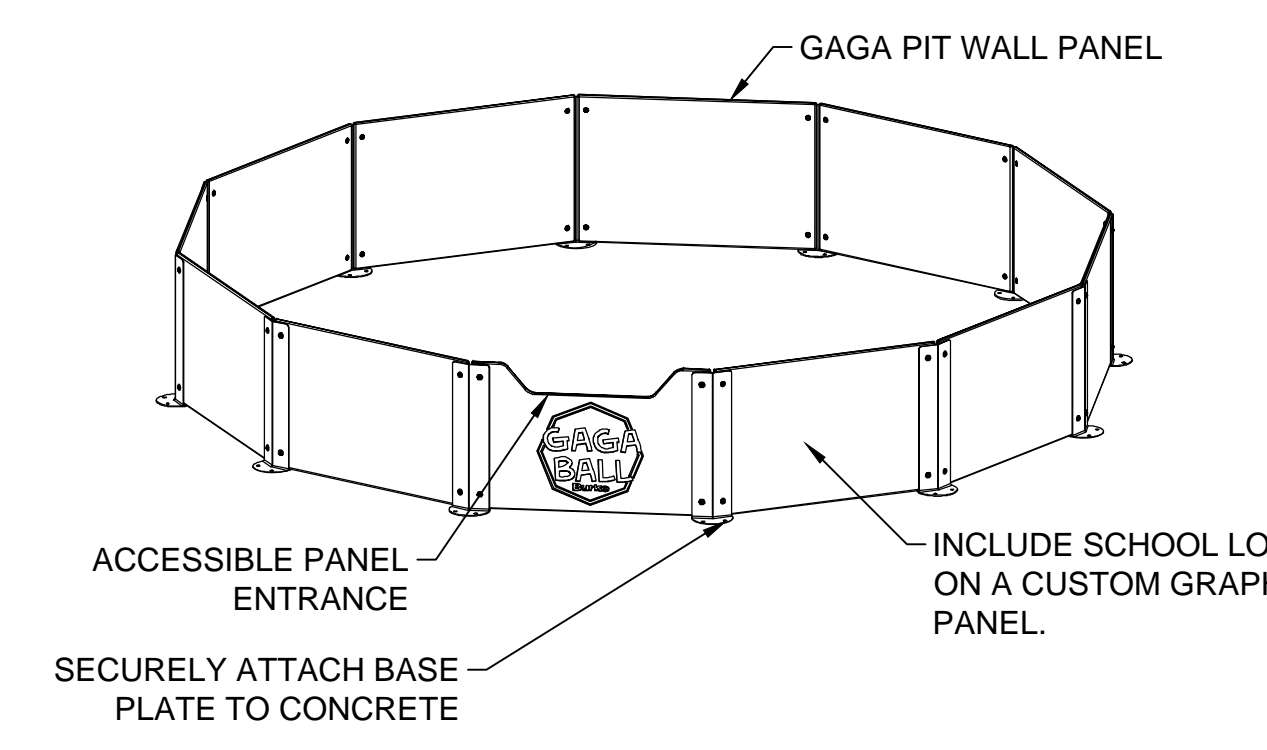

- NOTES:
1. GAGA BALL PIT TO BE BY BCIBURKE OR APPROVED EQUAL... WWW.BCIBURKE.COM
  2. CONTACT KRIS GOINS (918)-639-5676
  3. SUBMIT CUSTOM PANEL DESIGN AND COLORS PRIOR TO ORDERING.
  4. INCLUDE SURFACE MOUNT.
  5. INCLUDE RULES PANEL.

17 GAGA BALL PIT

# THE LAUNCHPAD



2021 BOND ISSUE PROJECT  
OAKDALE PUBLIC SCHOOLS



# CONCEPTUAL RENDERINGS

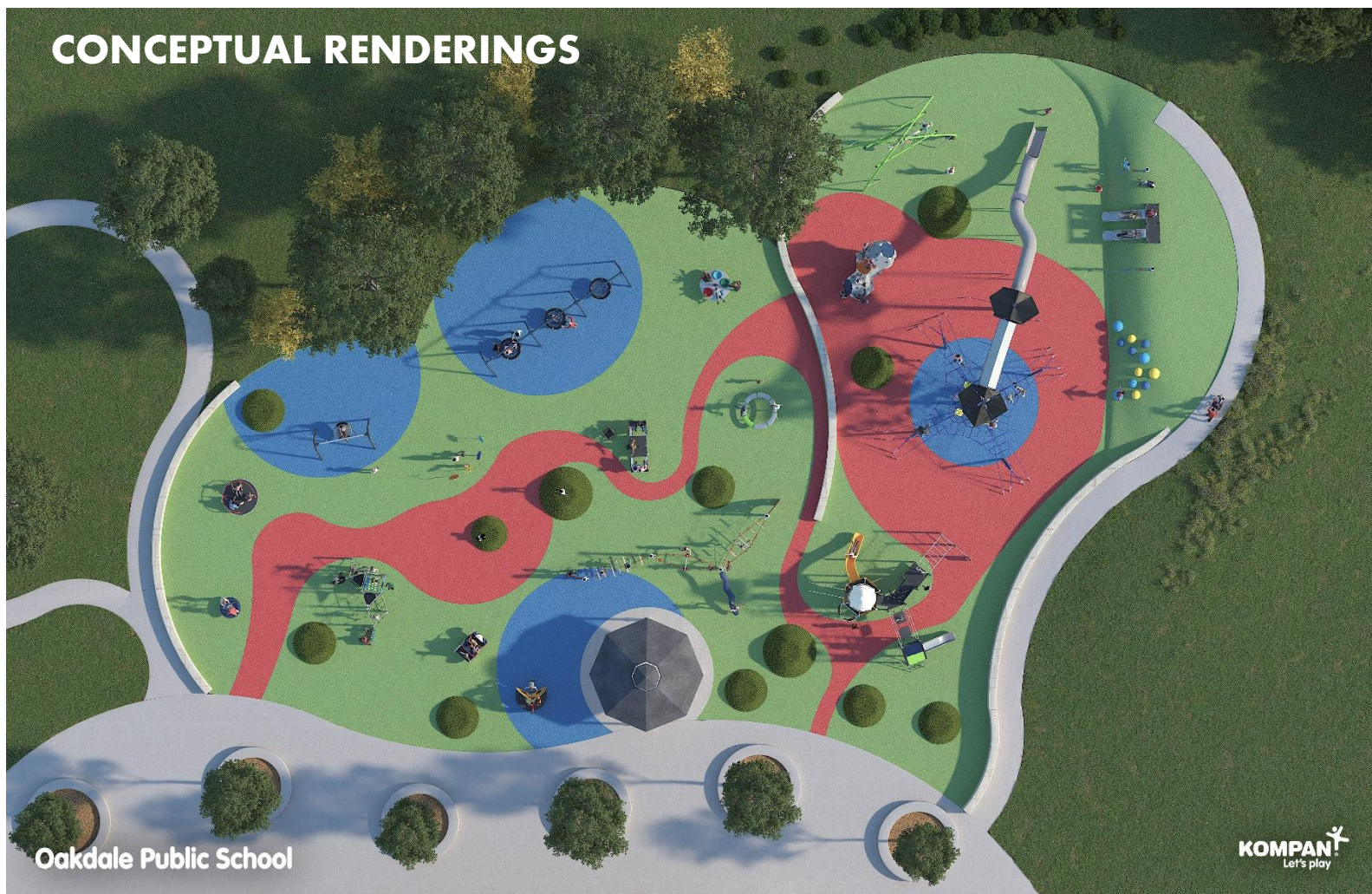

Oakdale Public School

KOMPAN!  
Let's play



Oakdale Public School

KOMPAN!  
Let's play

# CONCEPTUAL RENDERINGS



Oakdale Public School



Oakdale Public School



# CONCEPTUAL RENDERINGS



Oakdale Public School

KOMPAK!  
Let's play



Oakdale Public School

KOMPAK!  
Let's play

# CONCEPTUAL RENDERINGS



Oakdale Public School

**KOMPANI**  
Let's play

POURED IN PLACE PLAYGROUND SURFACING



ARTIFICIAL TURF PLAYGROUND SURFACING

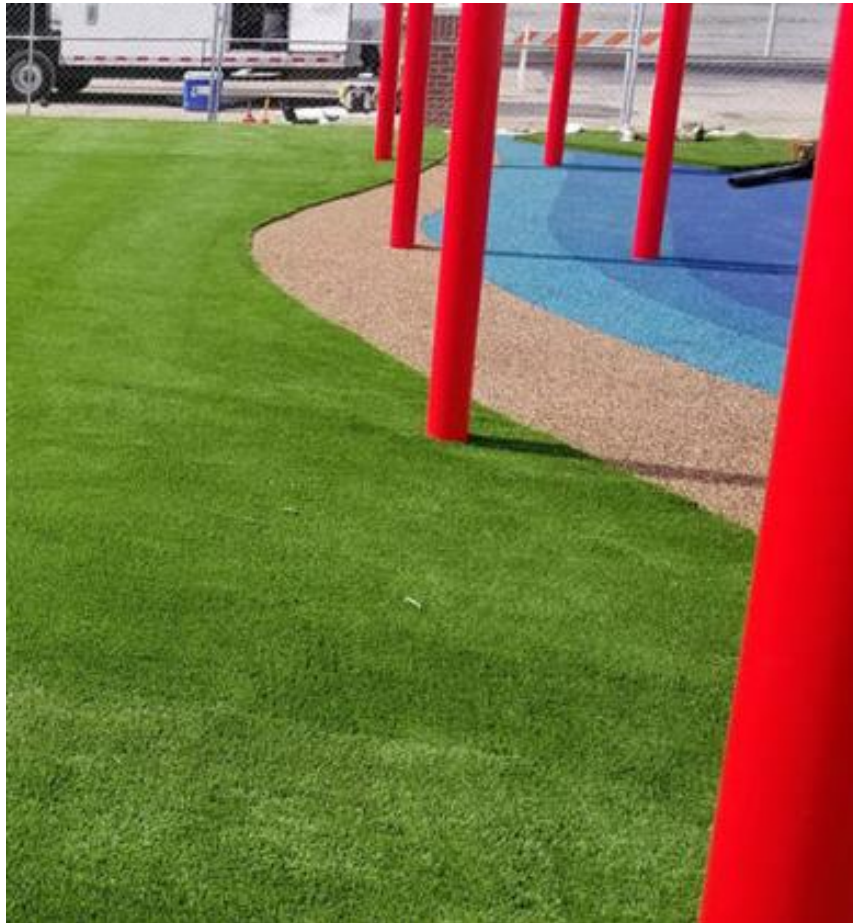



**CIRCULAR PAVER PATTERN**



**STABILIZED DECOMPOSED GRANITE**



**RUBY SPAR DECORATIVE BOULDERS**



DECORATIVE FENCE



AMPHITHEATER



ELECTRICAL PEDESTAL



MULTIPURPOSE SPORTS COURTS (BASKETBALL, PICKLEBALL, FOURSQUARE)



SOCCER GOAL/FIELD



GAGA BALL

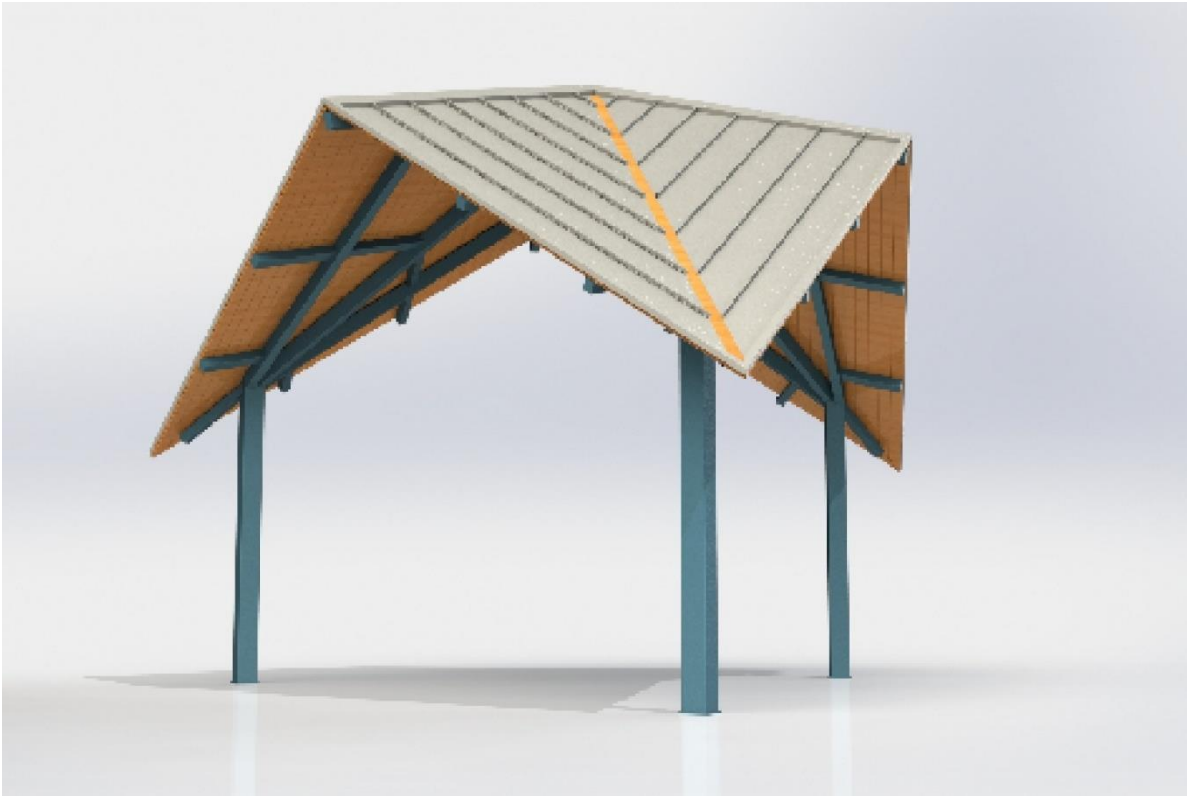

LARGE SHELTER



SMALL SHELTER (WITHOUT RAILING)



BENCH WITH OR WITHOUT BACK



MULTIPURPOSE COURT BENCH



TABLE



7 SPACE BIKE RACK

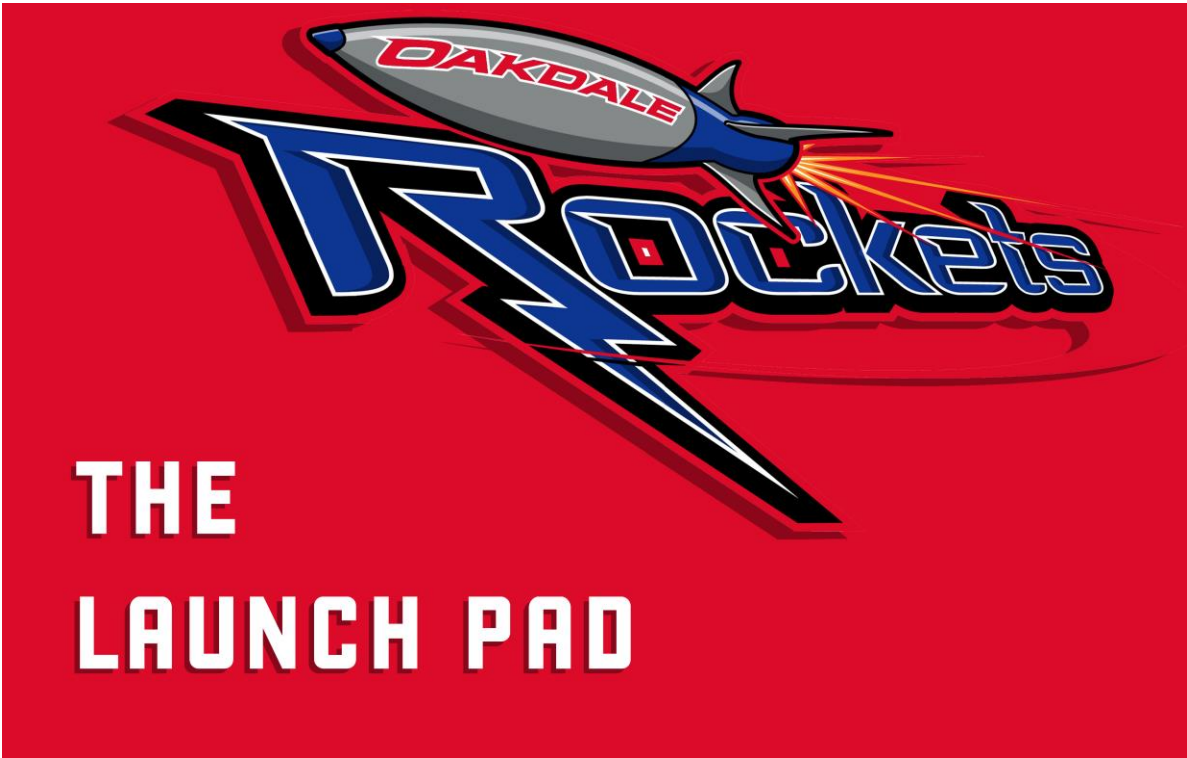

ENTRY SIGN



1 LANDSCAPE PLAN  
SCALE: 1"=30'

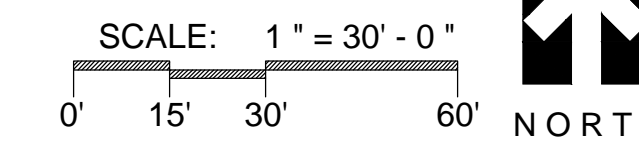

GENERAL NOTES:

- CONTRACTOR SHALL BE FAMILIAR WITH ALL EXISTING SITE CONDITIONS AND UNDERGROUND UTILITIES, PIPES, AND STRUCTURES. CONTRACTOR SHALL BE RESPONSIBLE FOR BODILY INJURY AND/OR ANY COST INCURRED DUE TO DAMAGE OF OWNER'S PROPERTY OR SAID UTILITIES. CONTRACTOR SHALL HAND DIG FOOTINGS, TREE WELLS, PLANTING BEDS, ETC. AS REQUIRED. CONTRACTOR IS RESPONSIBLE FOR CONTACTING UTILITY COMPANIES PRIOR TO ANY EXCAVATION.
- ANY CONFLICTING INFORMATION SHALL BE BROUGHT TO THE ATTENTION OF THE LANDSCAPE ARCHITECT OR THE LANDSCAPE ARCHITECT SHALL ASSUME THAT THE CONTRACTOR HAS INCORPORATED THE SPECIFIED ITEM.
- DO NOT WILLFULLY PROCEED WITH CONSTRUCTION OF DESIGN WHEN UNKNOWN OBSTRUCTIONS AND/OR GRADE DIFFERENCES EXIST THAT MAY NOT HAVE BEEN KNOWN DURING DESIGN. SUCH CONDITIONS SHALL BE IMMEDIATELY BROUGHT TO THE ATTENTION OF THE LANDSCAPE ARCHITECT. THE CONTRACTOR SHALL ASSUME FULL RESPONSIBILITY FOR ALL NECESSARY REVISIONS DUE TO FAILURE TO GIVE SUCH NOTIFICATION.
- CONTRACTOR SHALL NOTIFY LANDSCAPE ARCHITECT 48 HOURS PRIOR TO COMMENCEMENT OF WORK TO COORDINATE PROJECT INSPECTION SCHEDULES. CONTRACTOR SHALL FURNISH ALL LABOR, MATERIALS, EQUIPMENT, AND SERVICES NECESSARY TO PROVIDE ALL WORK. WORK TO BE COMPLETE IN PLACE AS SPECIFIED.
- ALL MATERIALS SHALL BE OF STANDARD, APPROVED AND FIRST GRADE QUALITY AND SHALL BE IN PRIME CONDITION WHEN INSTALLED AND ACCEPTED. ANY COMMERCIALY PROCESSED OR PACKAGED MATERIAL SHALL BE DELIVERED TO THE SITE IN THE ORIGINAL UNOPENED PACKAGING BEARING THE MANUFACTURER'S GUARANTEED ANALYSIS.
- PLANTS SHALL BE IN A MOIST, VIGOROUS CONDITION, FREE FROM DEAD WOOD, BRUISES OR OTHER ROOT OR BRANCH INJURIES. NO CONTAINER GROWN TREES OVER 2" CALIPER WILL BE ACCEPTED. THE LANDSCAPE ARCHITECT OR OWNER'S REPRESENTATIVE HAS THE RIGHT TO REJECT ANY PLANTS THAT HE/SHE FEELS DOES NOT MEET THE STANDARDS AS SET FORTH BY THE AMERICAN STANDARDS INSTITUTE (ANSI) PUBLICATIONS: Z60.1--LATEST EDITION. NO SUBSTITUTIONS SHALL BE ALLOWED WITHOUT APPROVAL OF THE LANDSCAPE ARCHITECT.
- QUANTITIES ON PLANT MATERIALS LIST ARE FOR CONVENIENCE ONLY. CONTRACTOR IS RESPONSIBLE FOR ALL PLANTS SHOWN ON PLANTING PLANS AND COVERAGE OF ALL AREAS DELINEATED. WHEN DISCREPANCIES OCCUR BETWEEN PLANT LIST AND PLANTING PLANS, THE PLANS ARE TO SUPERSEDE THE PLANT LIST IN ALL CASES.
- THE LOCATION OF PLANTS SHOWN ON THIS PLAN ARE APPROXIMATE. FIELD ADJUST PLANT LOCATIONS IF NECESSARY. VERIFY NEW LOCATION WITH LANDSCAPE ARCHITECT OR CITY REPRESENTATIVE, TYPICAL.
- MULCH ALL TREES AND PLANTING AREAS WITH 3" MINIMUM GRADE A SHREDDED CEDAR ALL BARK MULCH.
- IN ALL DISTURBED LAWN AREAS AND AS SHOWN, INSTALL U-3 BERMUDA SOD, CYNODON DACTYLON U-3.
- ALL LAWN AND PLANTING AREAS SHALL SLOPE TO DRAIN A MINIMUM OF 2% POSITIVE DRAINAGE UNLESS OTHERWISE NOTED. CONTRACTOR SHALL BE RESPONSIBLE AND BEAR COSTS OF RE-LANDSCAPING FOR GRADES.
- ALL ITEMS SHOWN ON THE PLANTING PLANS AND DETAILS SHALL BE INCLUDED IN THE COST OF THE PLANTING. THIS SHALL INCLUDE, BUT NOT BE LIMITED TO, TREE STAKING, FERTILIZING, EXCAVATION AND WATERING AS REQUIRED BY THE SPECIFICATIONS. ANY ITEM NOT LISTED ON THE BID SHEET SHALL BE CONSIDERED INCIDENTAL AND SHALL BE INCLUDED IN THE COST OF OTHER ITEMS.
- REFER TO SHEET LA-04 AND LA-05 FOR DETAILS/INSTRUCTIONS.

INSPECTION NOTES:

- CONTRACTOR SHALL BE RESPONSIBLE FOR NOTIFYING LANDSCAPE ARCHITECT FOR INSPECTION OF LANDSCAPING AT THE FOLLOWING TIMES:
  - VISIT ONE  
DELIVERY OF TREES, SHRUBS AND GROUND COVER.  
LAYOUT OF TREE AND BED LOCATIONS AND EXCAVATION OF TREE PLANTING PITS  
STAKING OF ANY CONCRETE EDGING OR HARDSCAPE
  - VISIT TWO  
COMPLETION OF PLANTING, PRIOR TO APPLICATION OF MULCH MATERIALS.
- CONTRACTOR SHALL NOTIFY LANDSCAPE ARCHITECT 48 HOURS PRIOR TO COMMENCEMENT OF WORK TO COORDINATE PROJECT INSPECTION SCHEDULES. LACK OF NOTICE, OR PROCEEDING WITH PLANTING WITHOUT INSPECTION MAY REQUIRE CONTRACTOR TO DIG UP TO REVEAL PLANTING PITS.
- PROVIDE THE LANDSCAPE ARCHITECT COPIES OF DELIVERY SHEETS SHOWING GENUS, SPECIES AND CULTIVAR NAMES AND QUANTITIES OF PLANTS DELIVERED OR PURCHASED.
- PROVIDE THE LANDSCAPE ARCHITECT COPIES OF TICKETS SHOWING PURCHASE OF TOPSOIL, MYCORRHIZAL FUNGI, MULCH, FERTILIZER AND OTHER PLANTING PRODUCTS.

QUANTITY	COMMON NAME	BOTANICAL NAME	SIZE	ROOTBALL	SPACING	REMARKS
17	OKLAHOMA REDBUD	CERCIS CANADENSIS 'OKLAHOMA'	2.5" CAL	B&B	AS SHOWN	
7	AMERICAN SYCAMORE	PLATANUS OCCIDENTALIS	3" CAL	B&B	AS SHOWN	
15	SHUMARD OAK	QUERCUS SHUMARDII	3" CAL	B&B	AS SHOWN	
3	ESCARPMENT LIVE OAK	QUERCUS VIRGINIANA ESCARPMENT	3" CAL	B&B	AS SHOWN	
14	CEDAR ELM	ULMUS CRASSIFOLIA	3" CAL	B&B	AS SHOWN	
<b>EVERGREEN TREES</b>						
8	ARIZONA CYPRESS	CUPRESSUS ARIZONICA	5-6' H	B&B	AS SHOWN	UNSHAURED
3	LOBLOLLY PINE	PINUS TAEDA	9-10' H	B&B	AS SHOWN	



5909 NW Expressway, Ste 600  
Oklahoma City, Oklahoma 73132  
Telephone: 406-722-7270  
Facsimile: 406-722-0374  
www.lwpb.com

NOT FOR  
CONSTRUCTION  
SCHEMATIC  
DESIGN

OAKDALE PUBLIC SCHOOLS  
OAKDALE 2021 INFRASTRUCTURE PROJECTS  
10901 N. SOONER RD, EDMOND, OK 73013

JOB NO: 20-1457-E883  
DATE: Issue Date

REVISIONS

3" CAL

DRAWING TITLE  
OVERALL SITE PLAN

LA-01



THE CONTRACTOR SHALL BE RESPONSIBLE FOR THE SAFETY OF ALL UTILITIES, PUBLIC OR PRIVATE, DURING CONSTRUCTION AND WILL SATISFY HIMSELF AS TO THEIR ACTUAL LOCATION PRIOR TO CONSTRUCTION. HE WILL NOTIFY THE UTILITY OWNERS OF ACTUAL TIMES OF CONSTRUCTION TO ALLOW THEIR PARTICIPATION.



825 N. Broadway, Suite 315  
Oklahoma City, OK 73102  
406-628-2200  
www.LandscapeArchitects.com

LOCAL FILE: 7/1/2021 12:05:27 PM  
CONTR. FILE: 20-1457-E883  
PLOT DATE: LWPB JOB  
MEMO: LWPB 2019.0002

OAKDALE PUBLIC SCHOOLS  
OAKDALE 2021 INFRASTRUCTURE PROJECTS  
10901 N. SOONER RD, EDMOND, OK 73013

JOB NO: 20-1457-E883  
DATE: Issue Date

REVISIONS

DRAWING TITLE  
HARDSCAPE PLAN

LA-02



1 HARDSCAPE AND DRAINAGE PLAN  
SCALE: 1"=10'

SCALE: 1" = 10' - 0"  
0' 5' 10' 20'



THE CONTRACTOR SHALL BE RESPONSIBLE FOR THE SAFETY OF ALL UTILITIES, PUBLIC OR PRIVATE, DURING CONSTRUCTION AND WILL SATISFY HIMSELF AS TO THEIR ACTUAL LOCATION PRIOR TO CONSTRUCTION. HE WILL NOTIFY THE UTILITY OWNERS OF ACTUAL TIMES OF CONSTRUCTION TO ALLOW THEIR PARTICIPATION.



LOCAL FILE: 7/1/2021 12:05:27 PM  
CADD FILE: 20-1457-E883  
PLOT DATE: LWPB JOB  
TEMPLATE: LWPB 2019.0002



**LEGEND**

- COLOR 1 - POURED IN PLACE RUBBER SURFACING REFER 2/LA-04
- COLOR 2 - POURED IN PLACE RUBBER SURFACING REFER 2/LA-04
- COLOR 3 - POURED IN PLACE RUBBER SURFACING REFER 2/LA-04
- TYPE A - ARTIFICIAL TURF PLAYGROUND SURFACING REFER 3/LA-04
- TYPE B - ARTIFICIAL TURF SURFACING REFER 4/LA-04
- TYPE A - 10' DIA X 3' TALL ARTIFICIAL TURF PLAY MOUND REFER 6/LA-04
- TYPE B - 8' DIA. X 18" TALL ARTIFICIAL TURF PLAY MOUND REFER 6/LA-04

PLAYGROUND SPHERES TYPE INDICATED

**1 HARDSCAPE AND PLAYGROUND PLAN**  
SCALE: 1"=10'

QUANTITY	UNIT	MODEL #	NAME	DETAIL
1 EA	PCM157		Universal Carousel	
1 EA	PCT809		Fun Point	
1 EA	KSW 93007		Basket Swing	
1 EA	ELE 400065		Tipi	
1 EA	KSW 926_20123936		3 basket swing	
1 EA	MOM162120		Space Themed Seesaw	
1 EA	GSP0008		Mars Rover	
1 EA	COR20840		Triple Rope Trail	
1 EA	GXY960		Supernova	
1 EA	M7021		Triple Shifter	
1 EA	BLX4103		Bloga 3	
1 EA	PCM724017		Rocket PCM Tower	
1 EA	ELE 400762		Multi Spinner	
1 EA	M984		Cocowave	
1 EA	KNS8500238		Custom Skywalk	
1 EA	PCM724017		Double Embankment Slides 4' Hill	
2 EA	COR10545		Mountaineering Ropes	
8 EA	SUR13361		EUR OF LEX HALF BAL D500MM	
4 EA	SUR13362		EUR OF LEX HALF BAL D695MM	
5F			PLAYGROUND SAFETY SURFACING - ARTIFICIAL TURF	FOREVER LAWN, OR APPROVED EQUAL
5F			PLAYGROUND SAFETY SURFACING - POURED IN PLACE	DURAPLAY, OR APPROVED EQUAL

**NOTE:**

- PLAYGROUND EQUIPMENT TO BE BY KOMPAN OR APPROVED EQUAL  
1.1. CONTACT: KRISTIN SEIFRIED 405-226-7467
- COLOR PALETTE TO INCLUDE THE FOLLOWING:  
- PLAYGROUND EQUIPMENT  
- POURED IN PLACE SURFACING  
- ARTIFICIAL TURF
- DIAMETER OF PLAYGROUND SPHERES INDICATED ON PLAN  
- 1 = 2' 3-3/8" DIA. FULL SPHERE  
- 2 = 1' 7-3/4" DIA. HALF SPHERE  
- 3 = 1' 1-3/4" DIA. FULL SPHERE

**NOTE:**  
SPOT GRADES ARE TO TOP OF POURED IN PLACE SURFACING

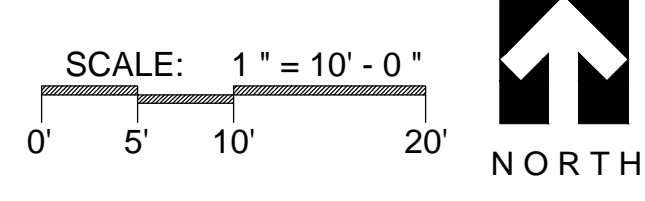

LOCAL FILE: 7/1/2021 12:05:27 PM  
PLOT DATE: 20-1457-E883  
LWPB JOB: LWPB 2019.0002  
TEMPLATE:



THE CONTRACTOR SHALL BE RESPONSIBLE FOR THE SAFETY OF ALL UTILITIES, PUBLIC OR PRIVATE, DURING CONSTRUCTION AND WILL SATISFY HIMSELF AS TO THEIR ACTUAL LOCATION PRIOR TO CONSTRUCTION. HE WILL NOTIFY THE UTILITY OWNERS OF ACTUAL TIMES OF CONSTRUCTION TO ALLOW THEIR PARTICIPATION.





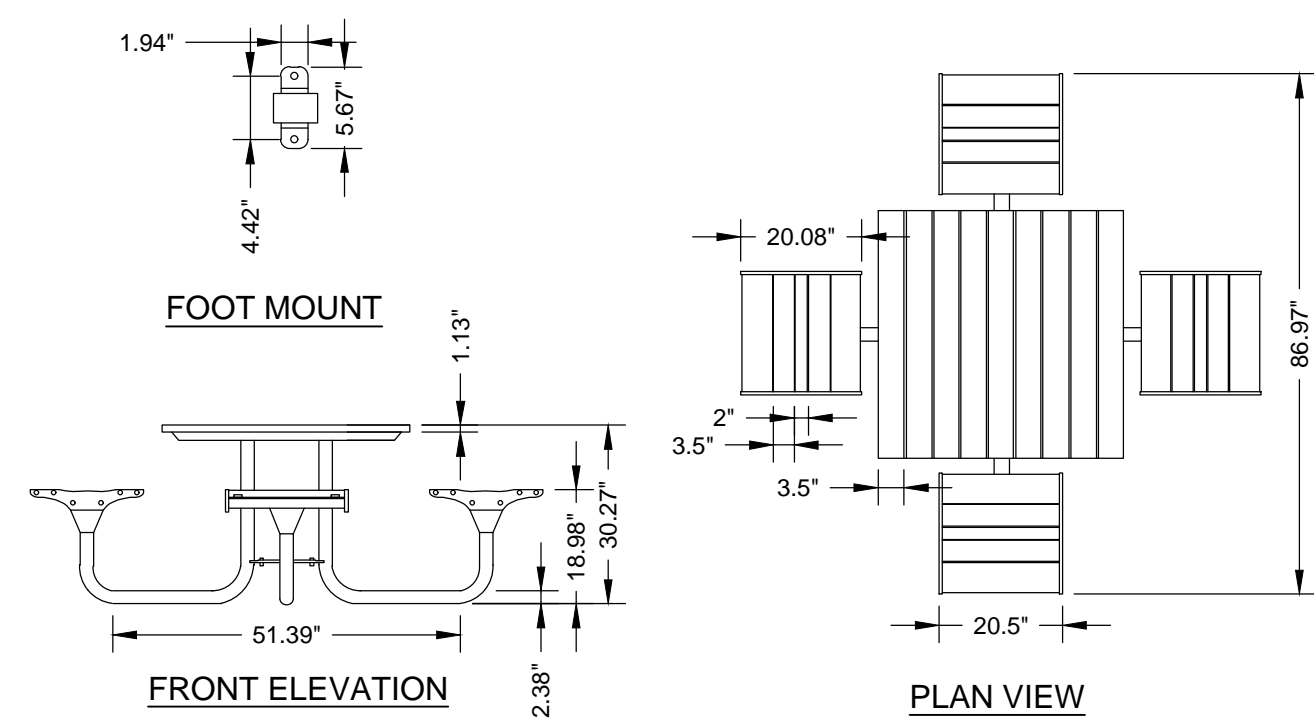

NOTES:

1. TABLE TO BE BEACON HILL MODEL BH1841R-GT BY ANOVA SITE FURNISHINGS OR APPROVED EQUAL... WWW.ANOVAFURNISHINGS.COM
2. CONTACT CHRISTOPHER TORRES (816)-602-4486
3. INCLUDE SURFACE MOUNT.
4. INCLUDE RECYCLED PLASTIC PLANKS.
5. SUBMIT COLOR SAMPLES FOR APPROVAL PRIOR TO ORDERING.
6. IF ACCESSIBLE TABLE IS SHOWN ON PLAN USE MODEL NUMBER BH1831R-GT

1 42" SQUARE TABLE - ANOVA

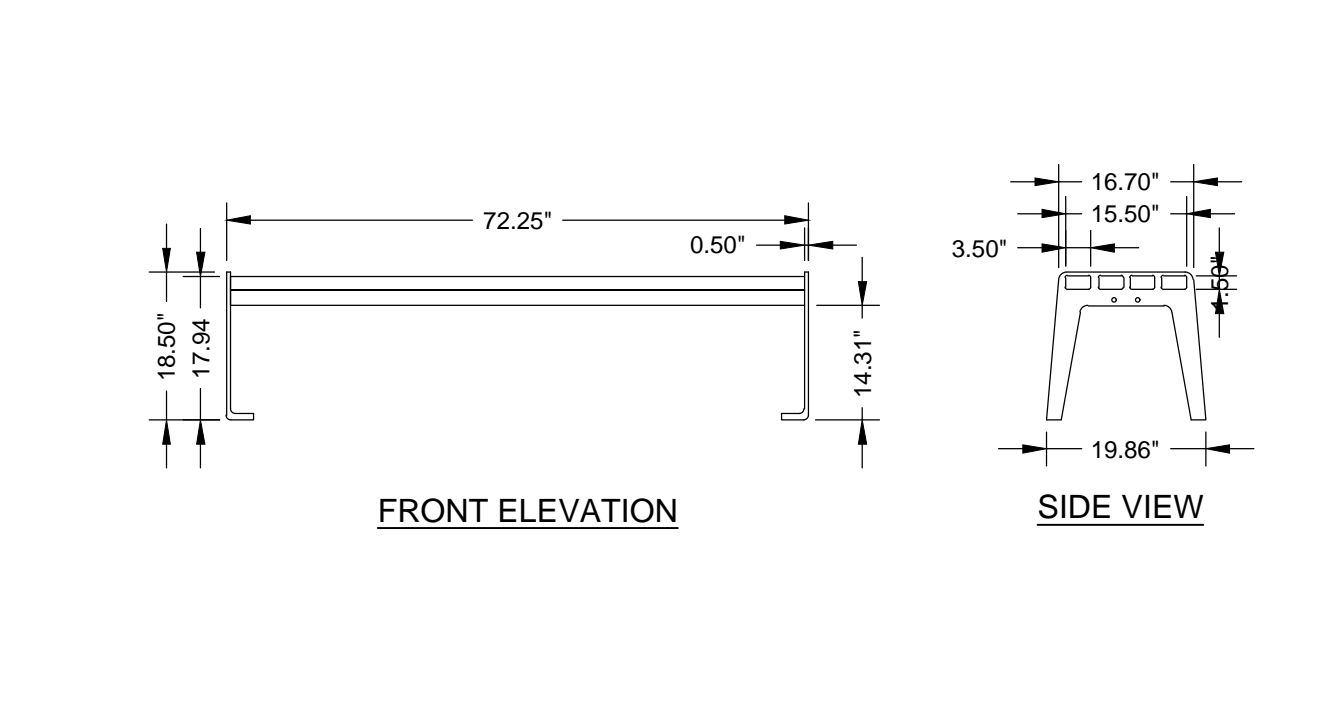

NOTES:

1. BENCH WITHOUT BACK TO BE MADISON 6' CONTOUR BENCH BY ANOVA SITE FURNISHINGS OR APPROVED EQUAL... WWW.ANOVAFURNISHINGS.COM
2. CONTACT CHRISTOPHER TORRES (816)-602-4486
3. INCLUDE SURFACE MOUNT.
4. INCLUDE RECYCLED PLASTIC PLANKS.
5. SUBMIT COLOR SAMPLES FOR APPROVAL PRIOR TO ORDERING.

2 6' BENCH WITH OUT BACK - ANOVA

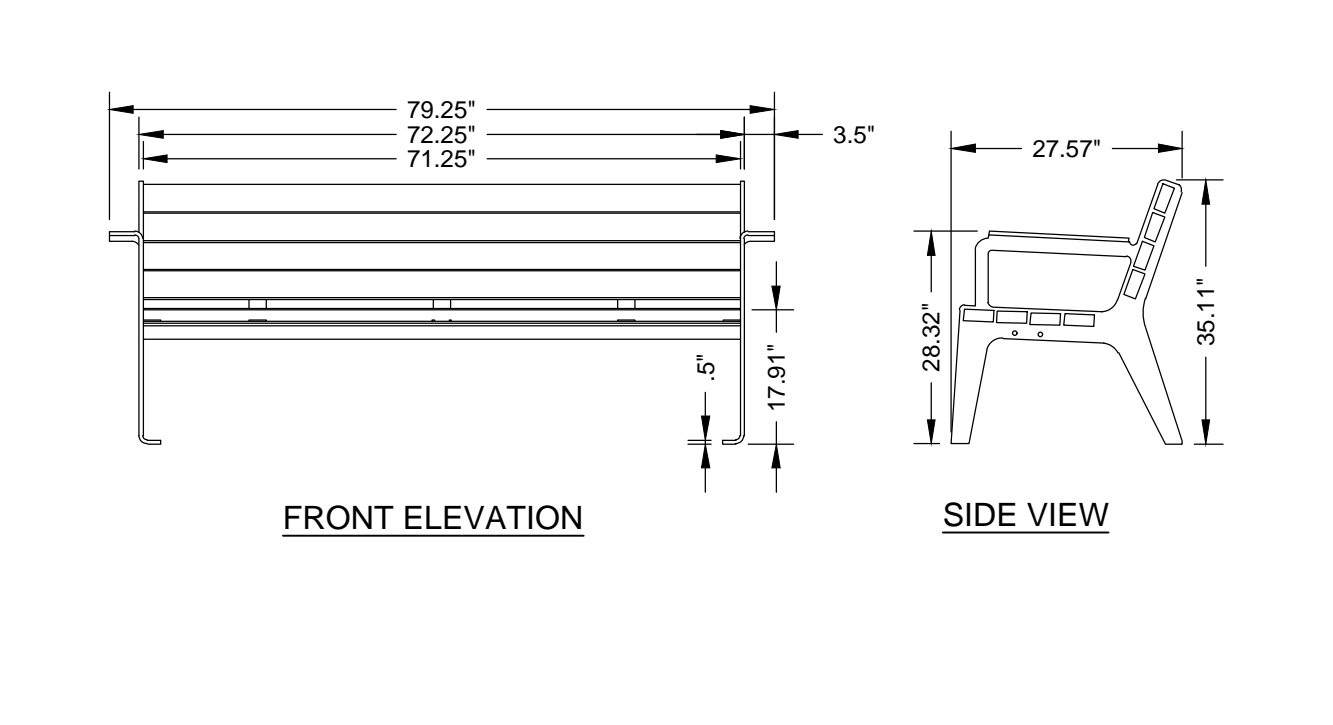

NOTES:

1. BENCH WITH BACK TO BE MADISON 6' CONTOUR BENCH BY ANOVA SITE FURNISHINGS OR APPROVED EQUAL... WWW.ANOVAFURNISHINGS.COM
2. CONTACT CHRISTOPHER TORRES (816)-602-4486
3. INCLUDE SURFACE MOUNT.
4. INCLUDE RECYCLED PLASTIC PLANKS.
5. SUBMIT COLOR SAMPLES FOR APPROVAL PRIOR TO ORDERING.

3 6' BENCH - ANOVA

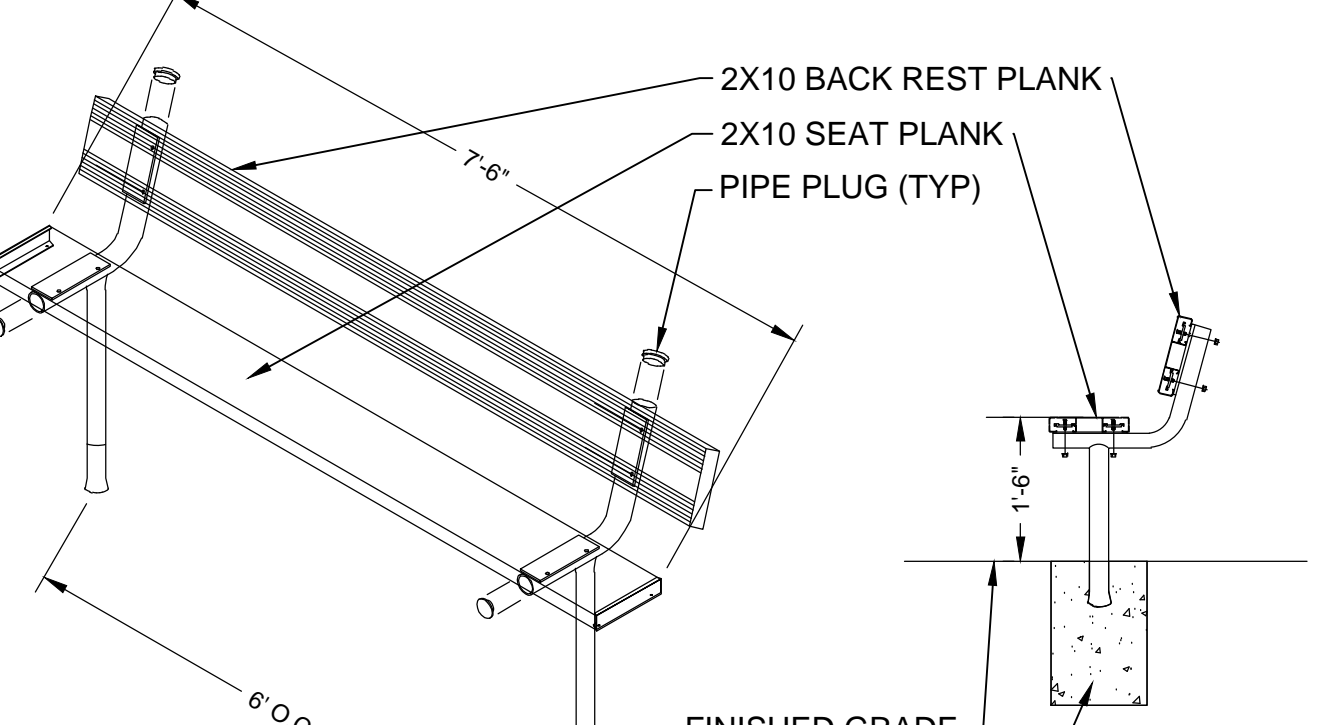

NOTE:

1. ALUMINUM PLAYER BENCHES WITH BACKRESTS (MODEL AB75WB-I), BY BELSON OUTDOORS OR APPROVED EQUAL (WWW.BELSON.COM)
2. INCLUDE INGROUND MOUNT
3. INSTALL PER MANUFACTURER'S RECOMMENDATIONS

4 7'-6" ALUMINUM BENCH - BELSON

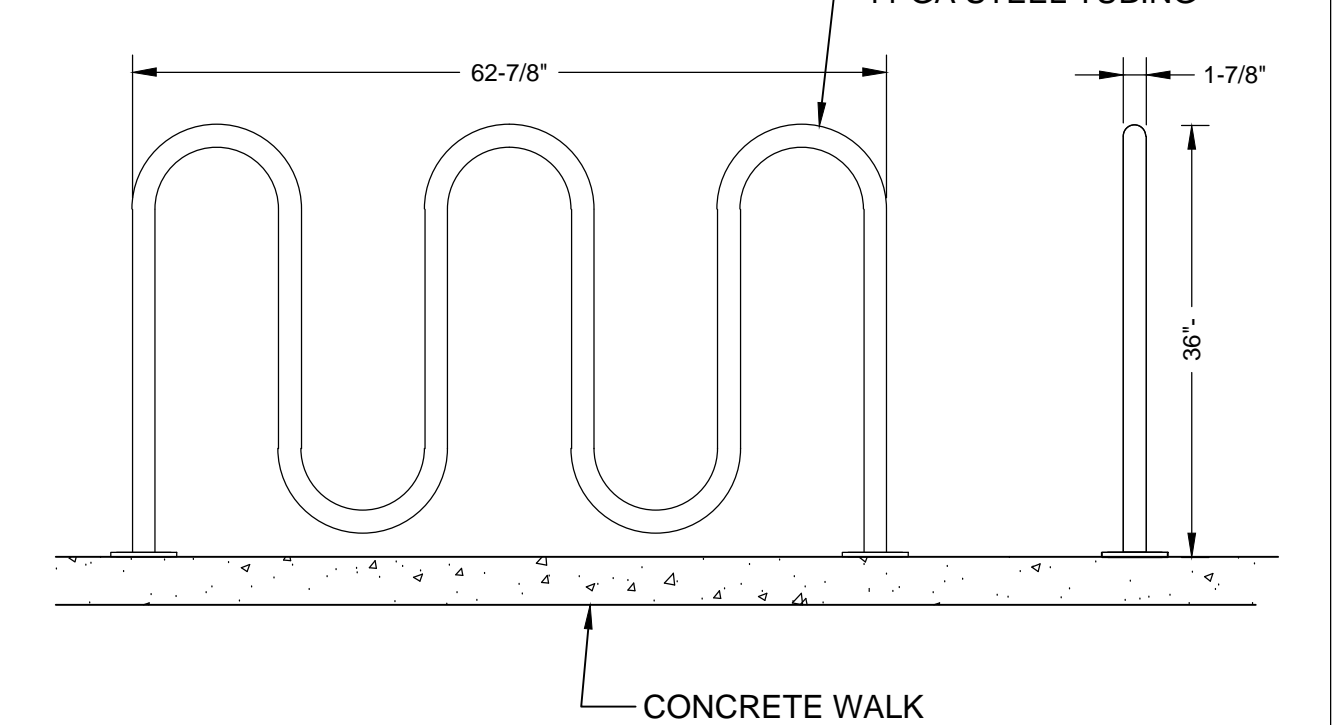

NOTE:

1. BIKE RACK SHALL BE STAINLESS STEEL 7 WAVE RACK, MODEL # CBBR-9UR-SS BY BELSON OUTDOORS. WWW.BELSON.COM, OR EQUAL. INSTALL PER MANUFACTURER'S RECOMMENDATIONS.

5 BIKE RACK - 7 SPACE - BELSON

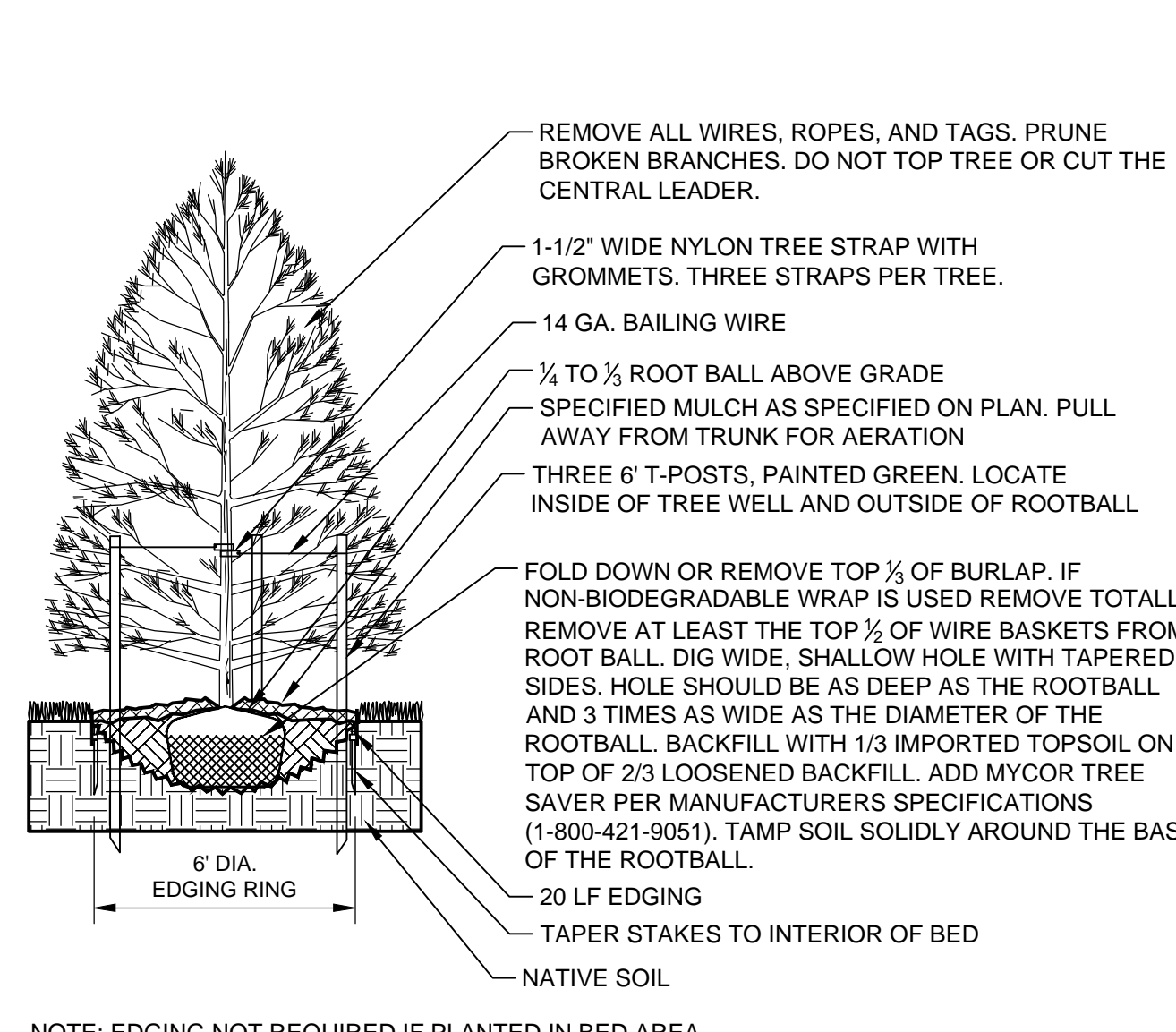

6 TREE PLANTING

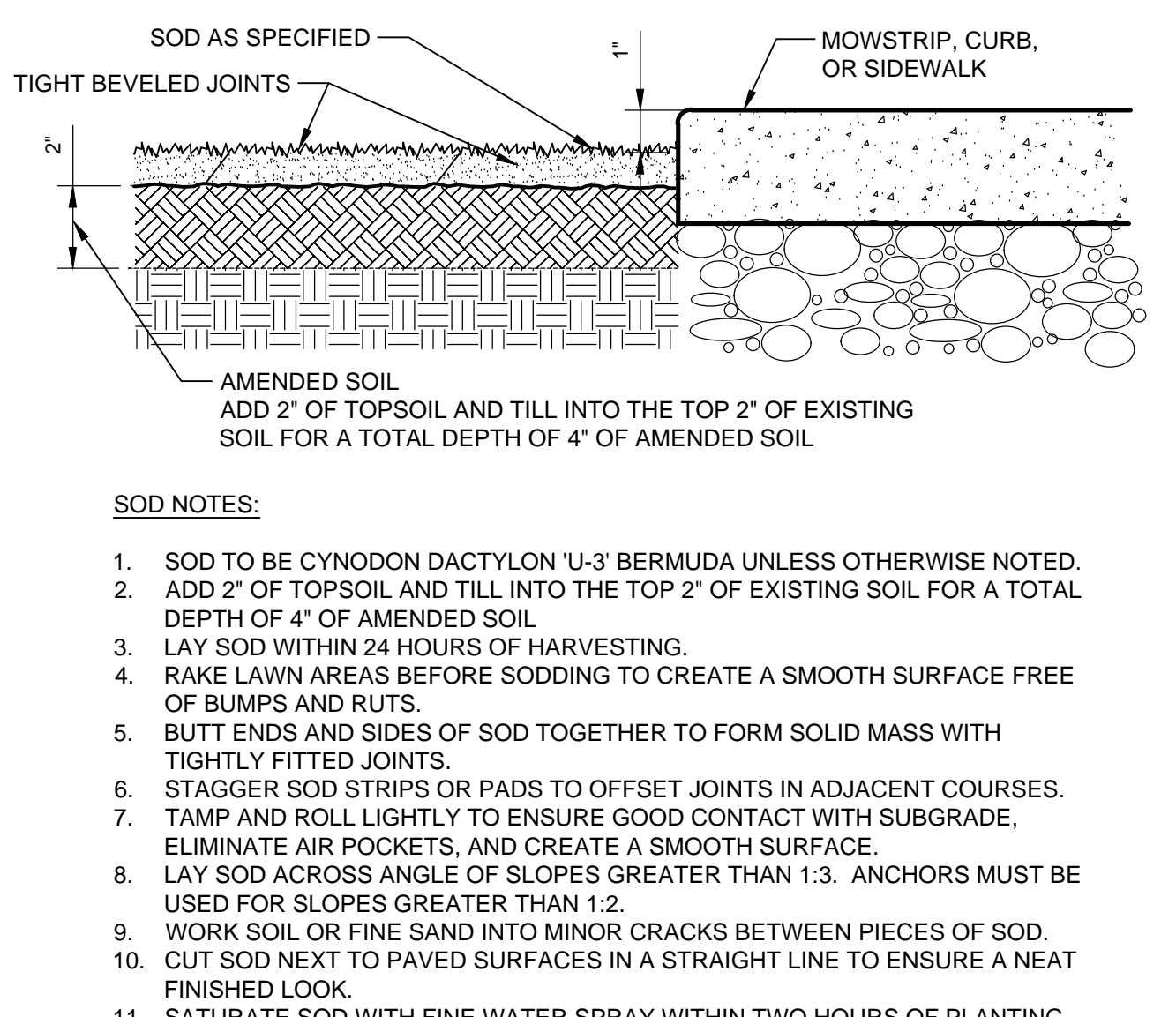

7 SOD INSTALLATION

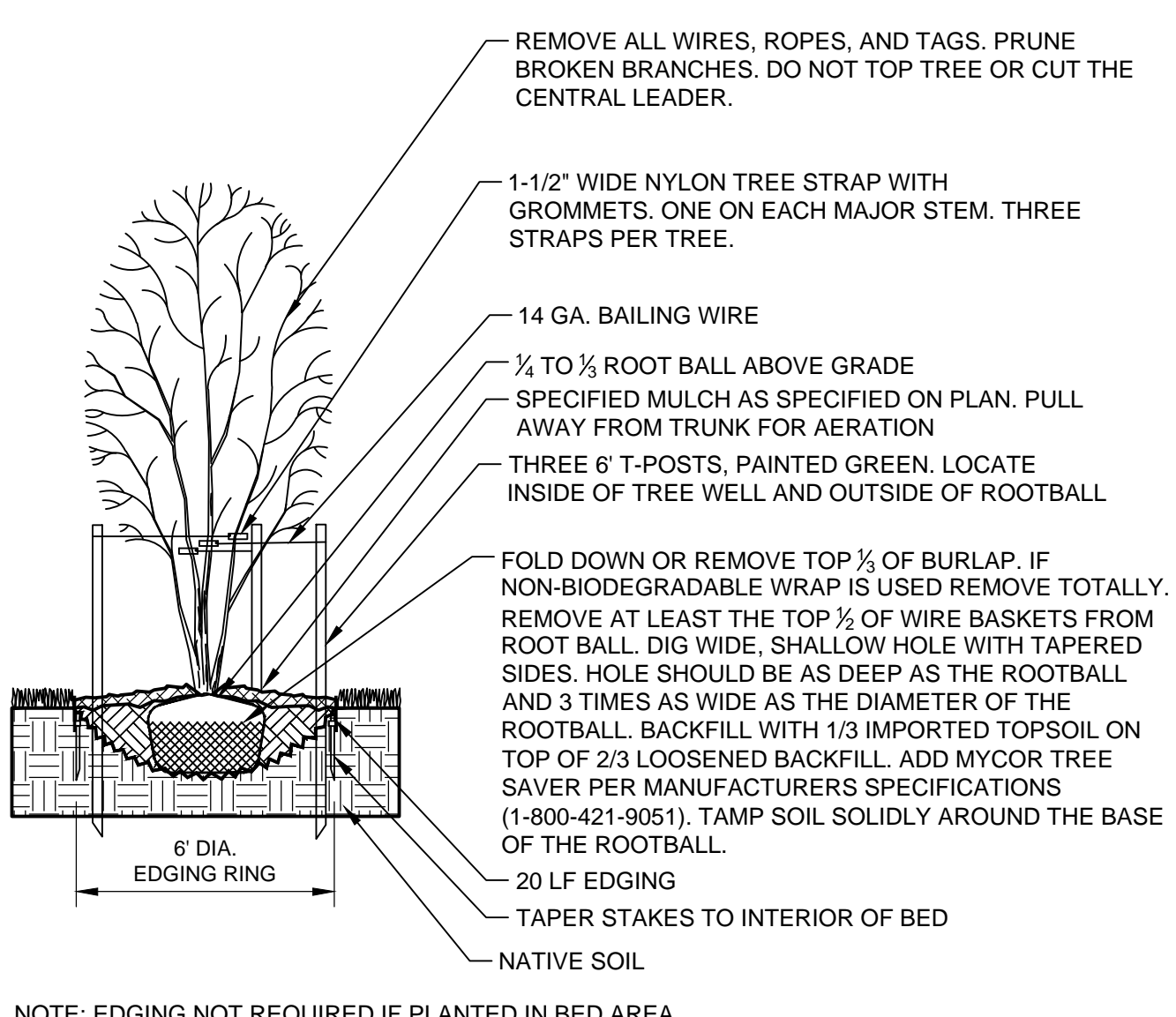

8 MULTI-STEM TREE PLANTING

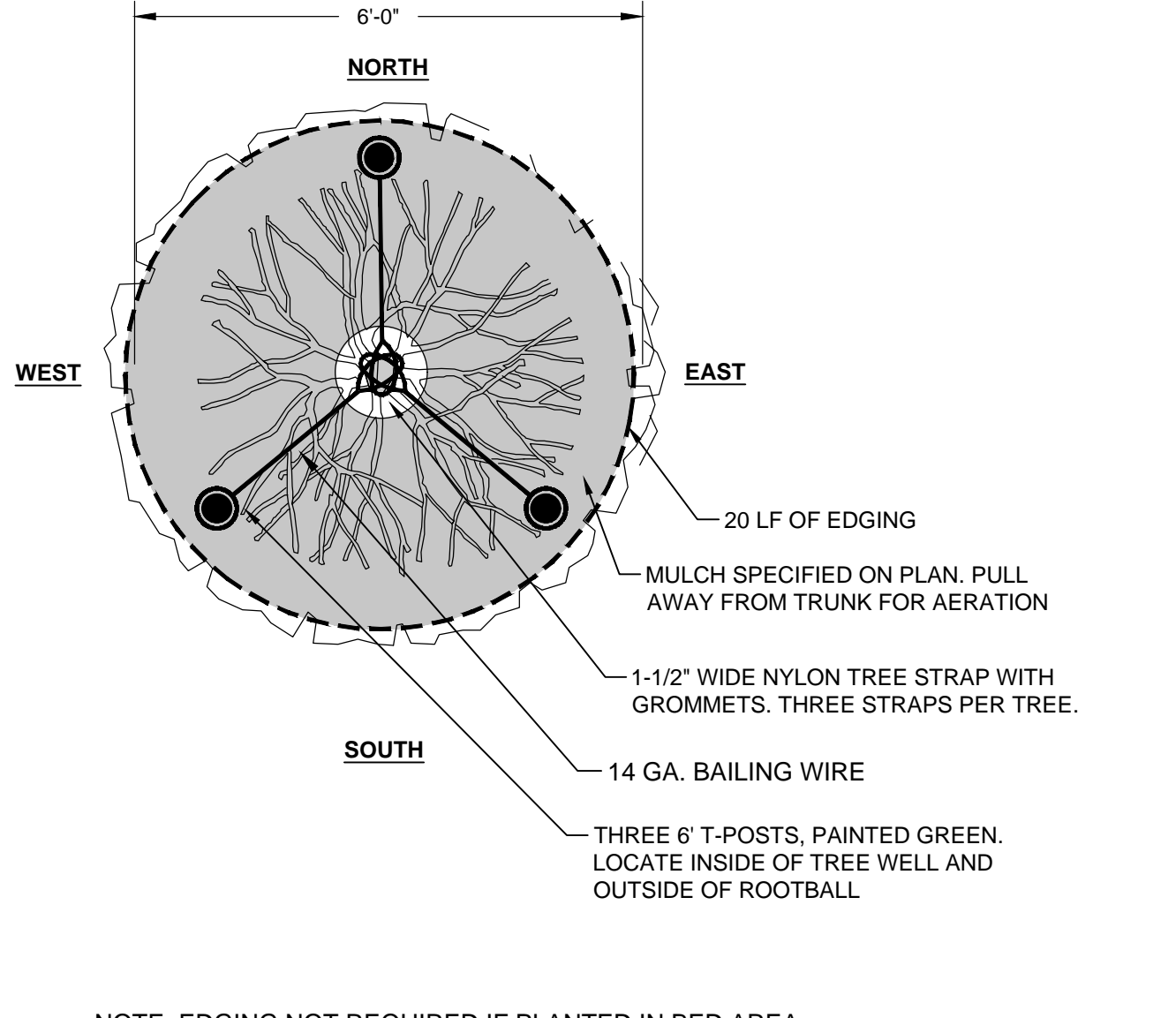

9 TREE STAKING

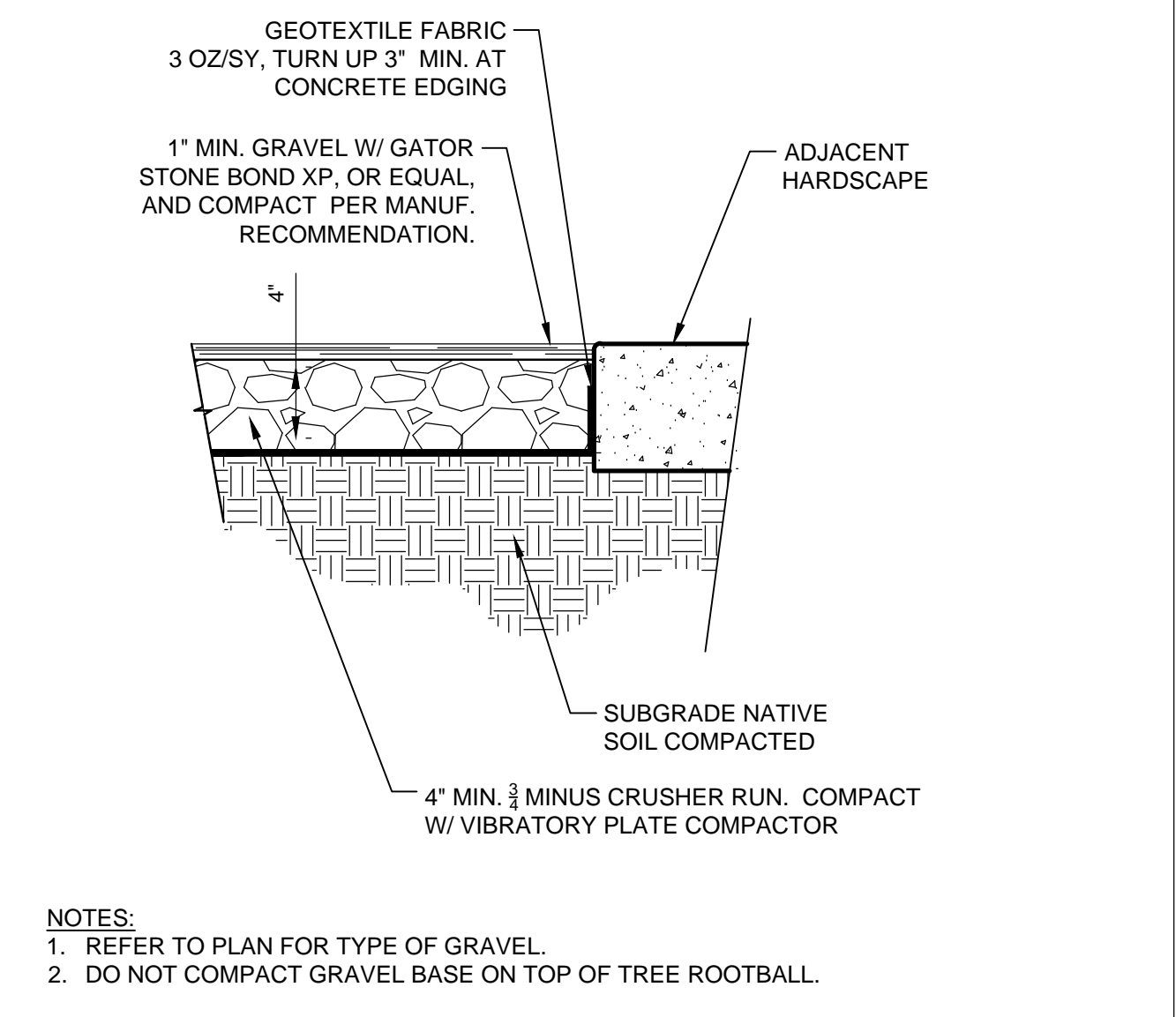

10 STABILIZED GRAVEL AT TREE - GATOR BOND

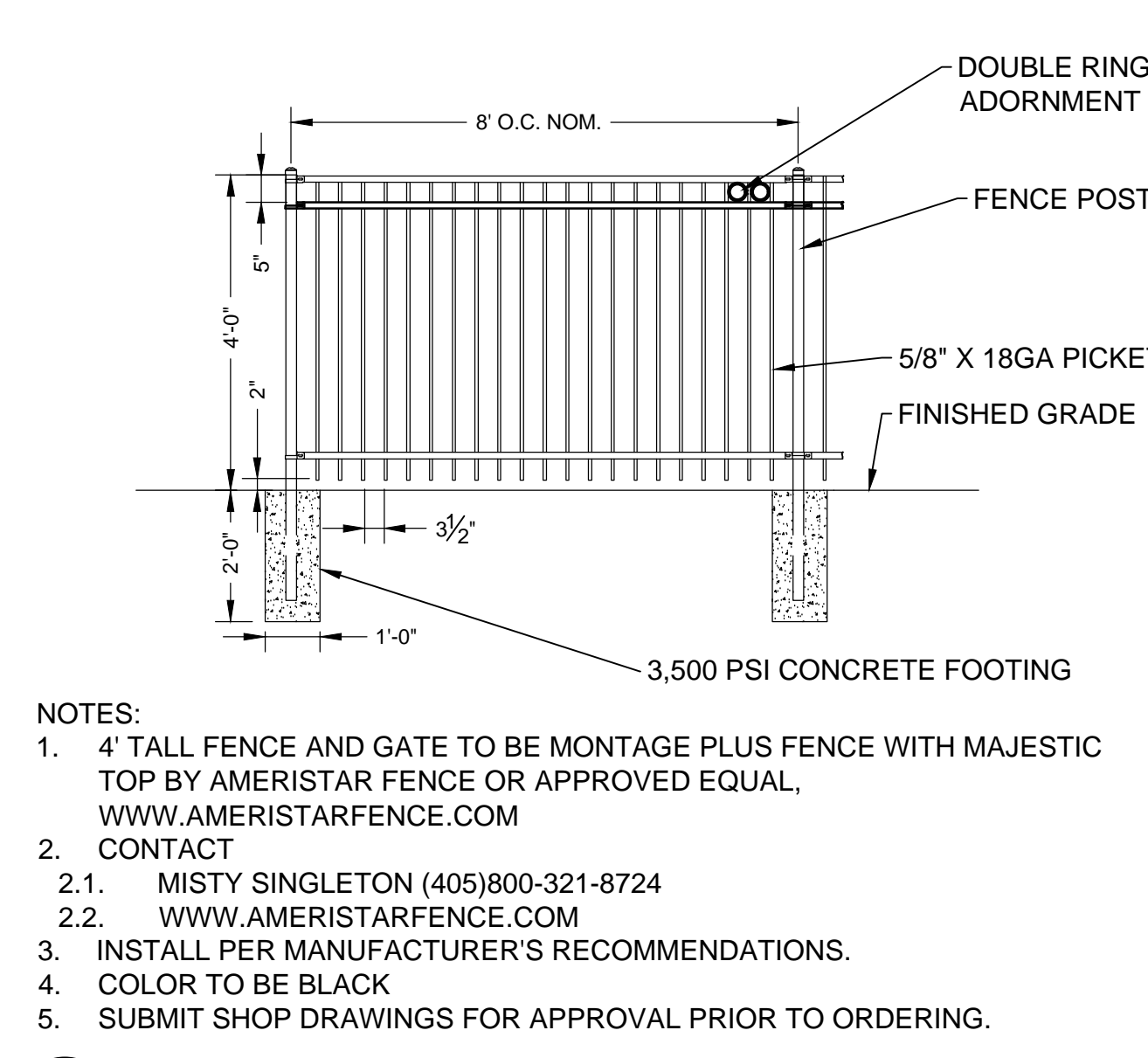

11 4' TALL DECORATIVE FENCE

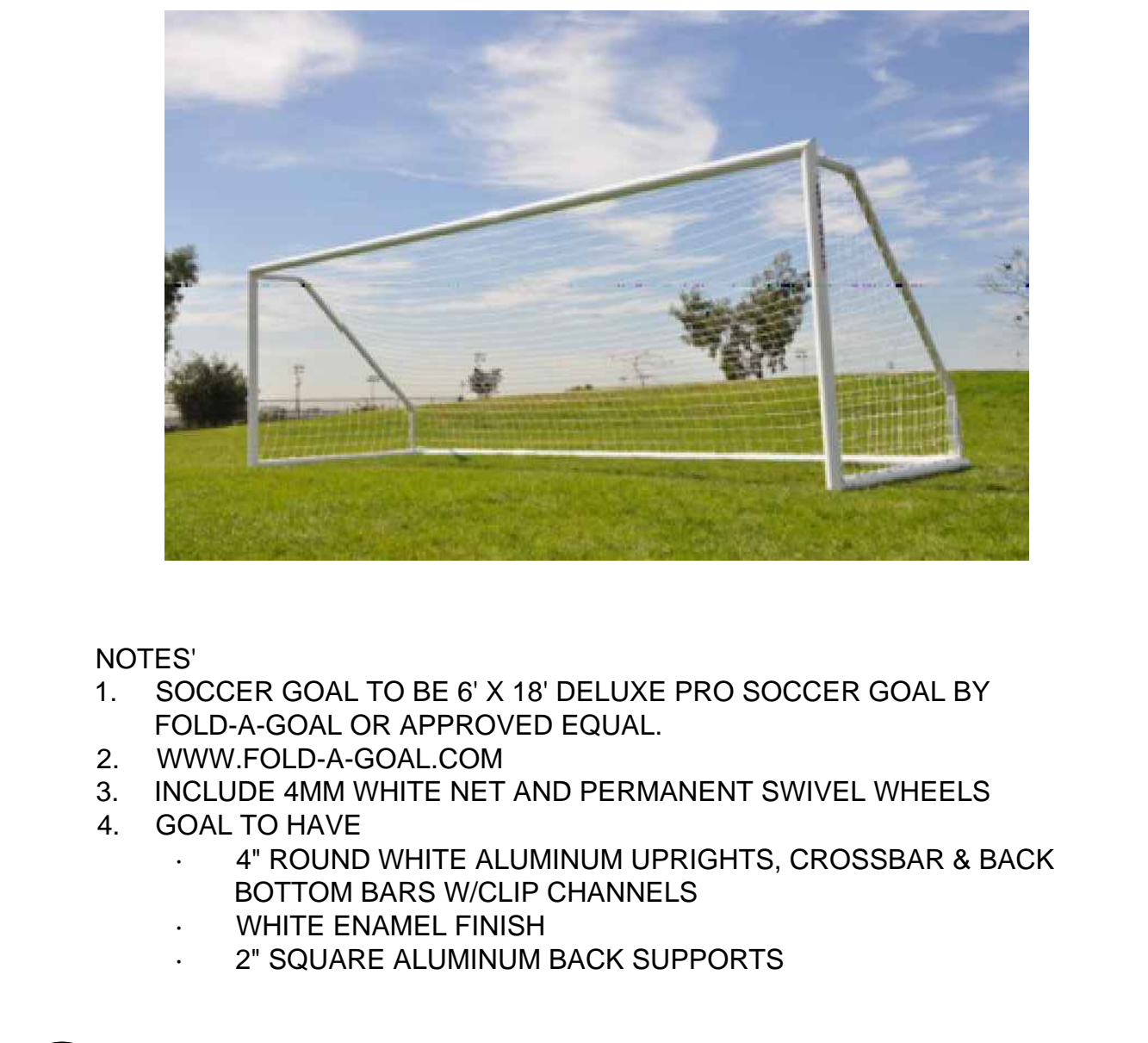

12 SOCCER GOAL

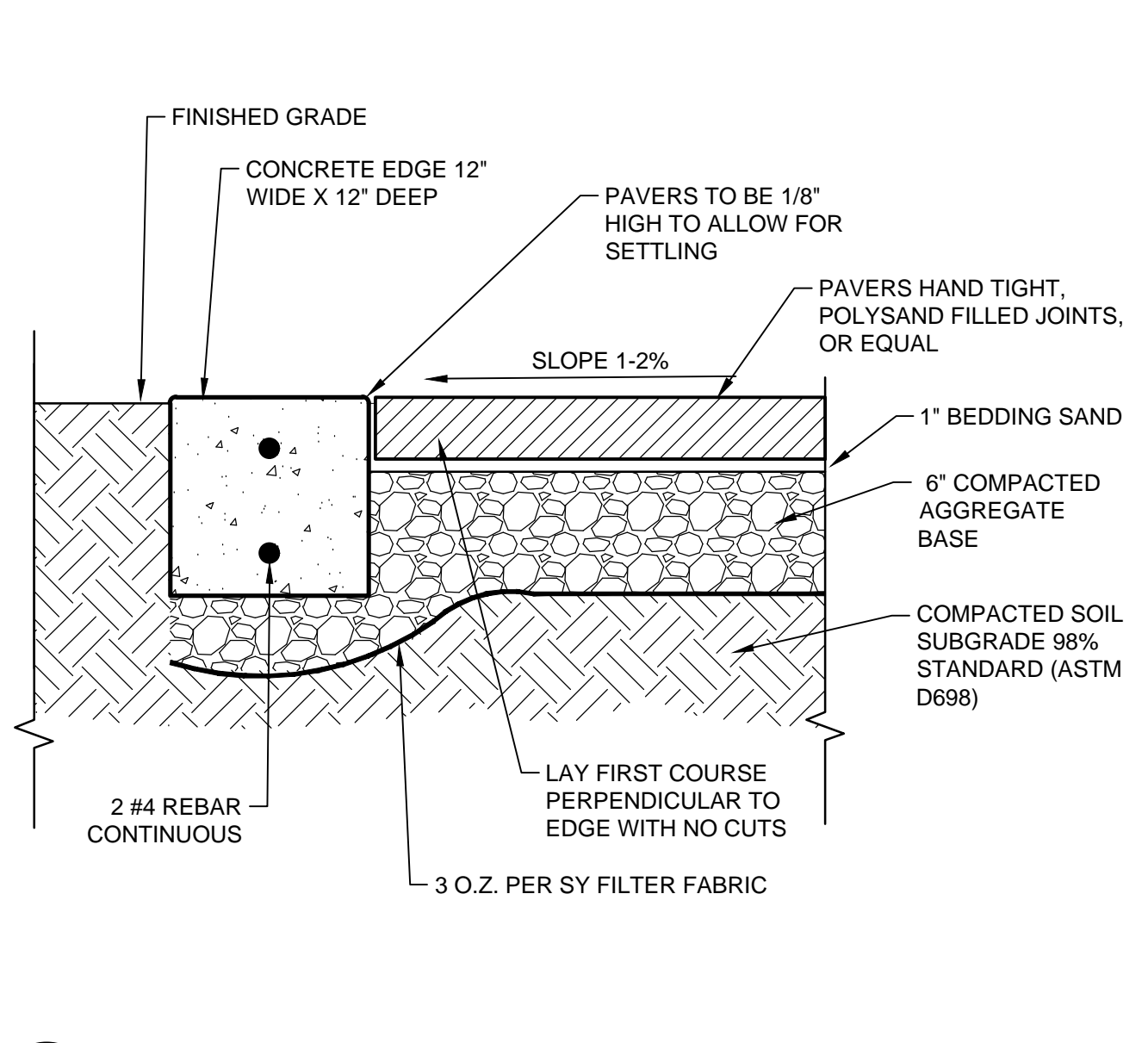

13 PAVERS ON GRAVEL BASE

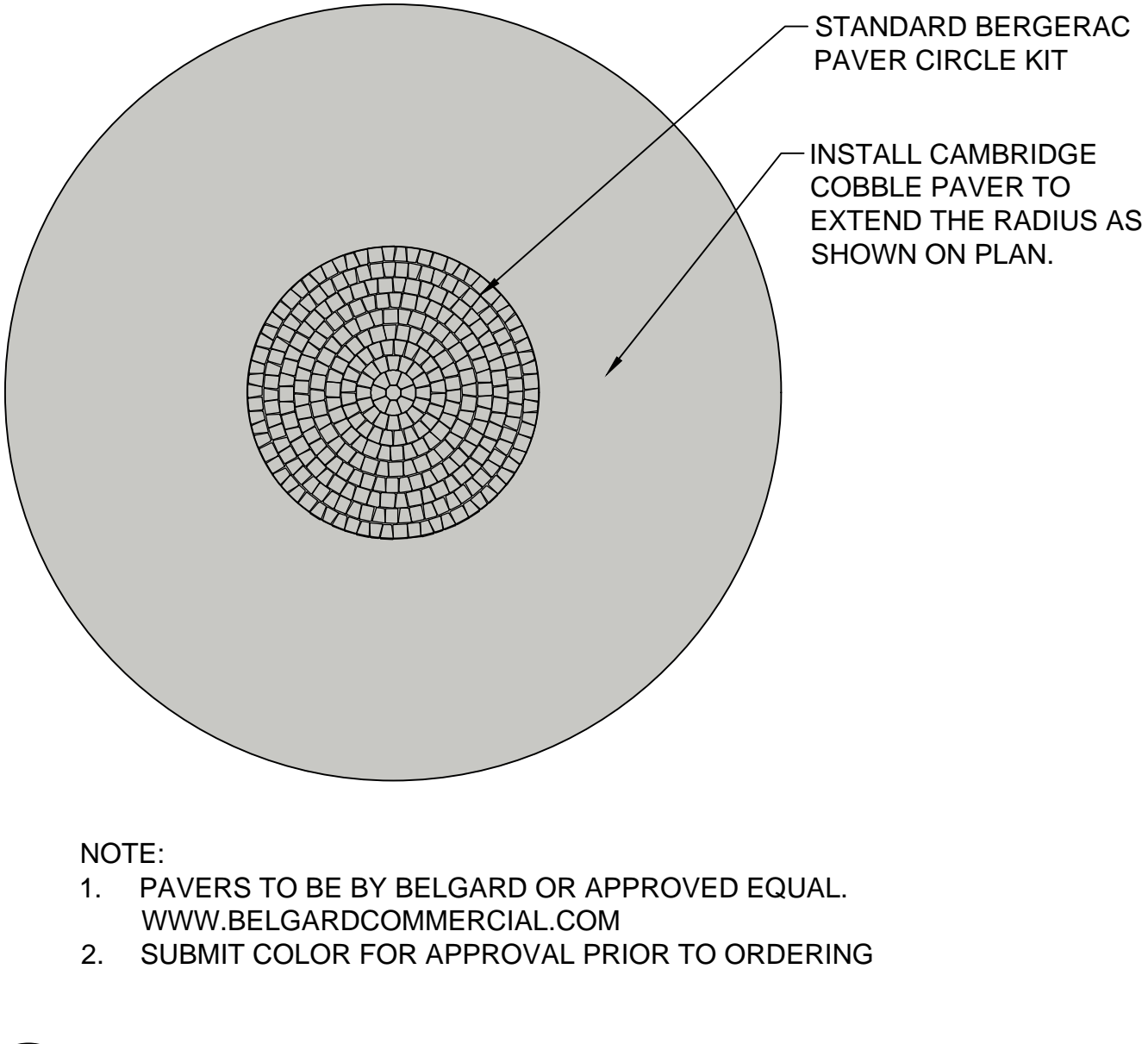

14 PAVER PATTERN - BERGERAC

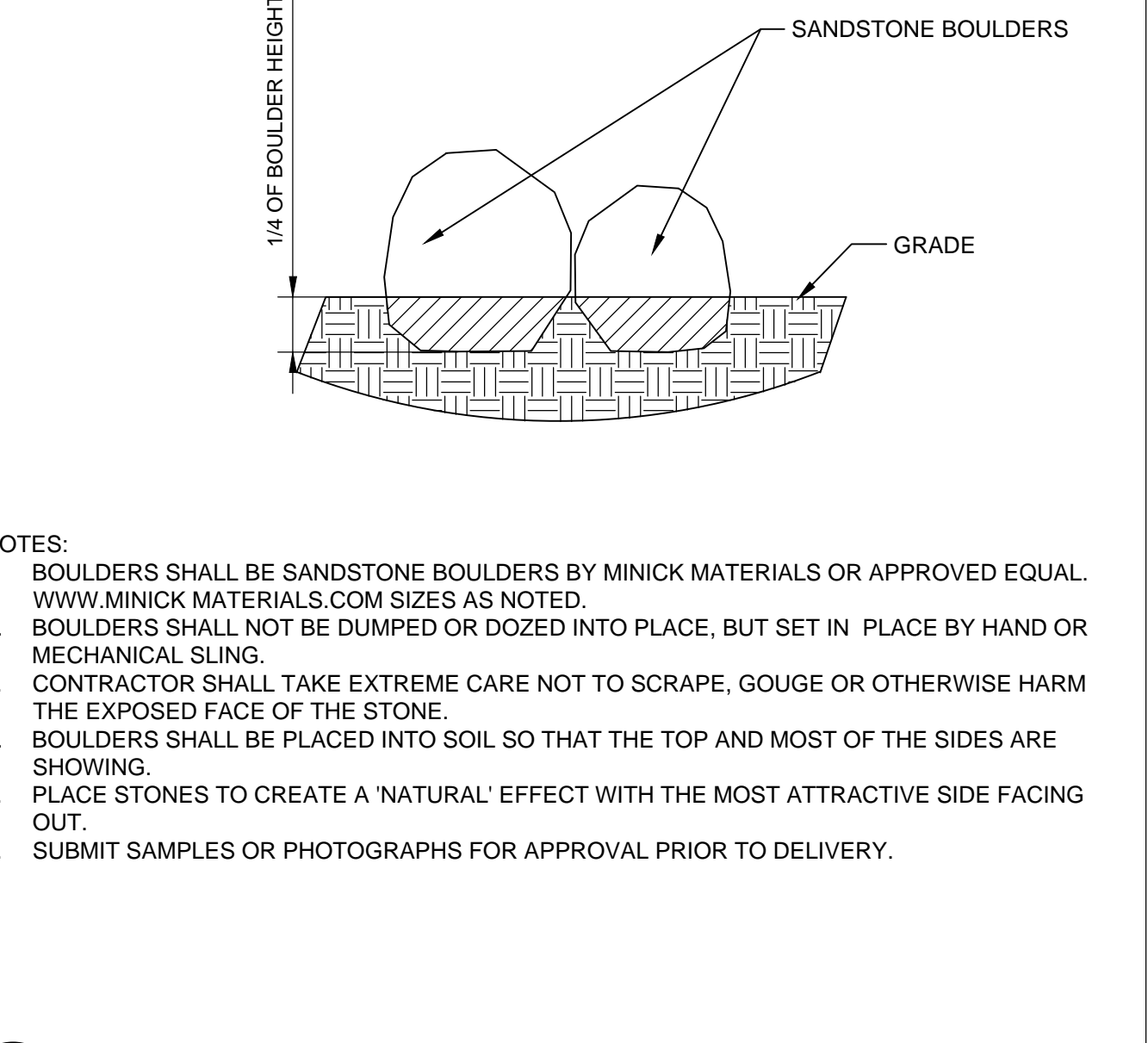

15 BOULDER INSTALLATION

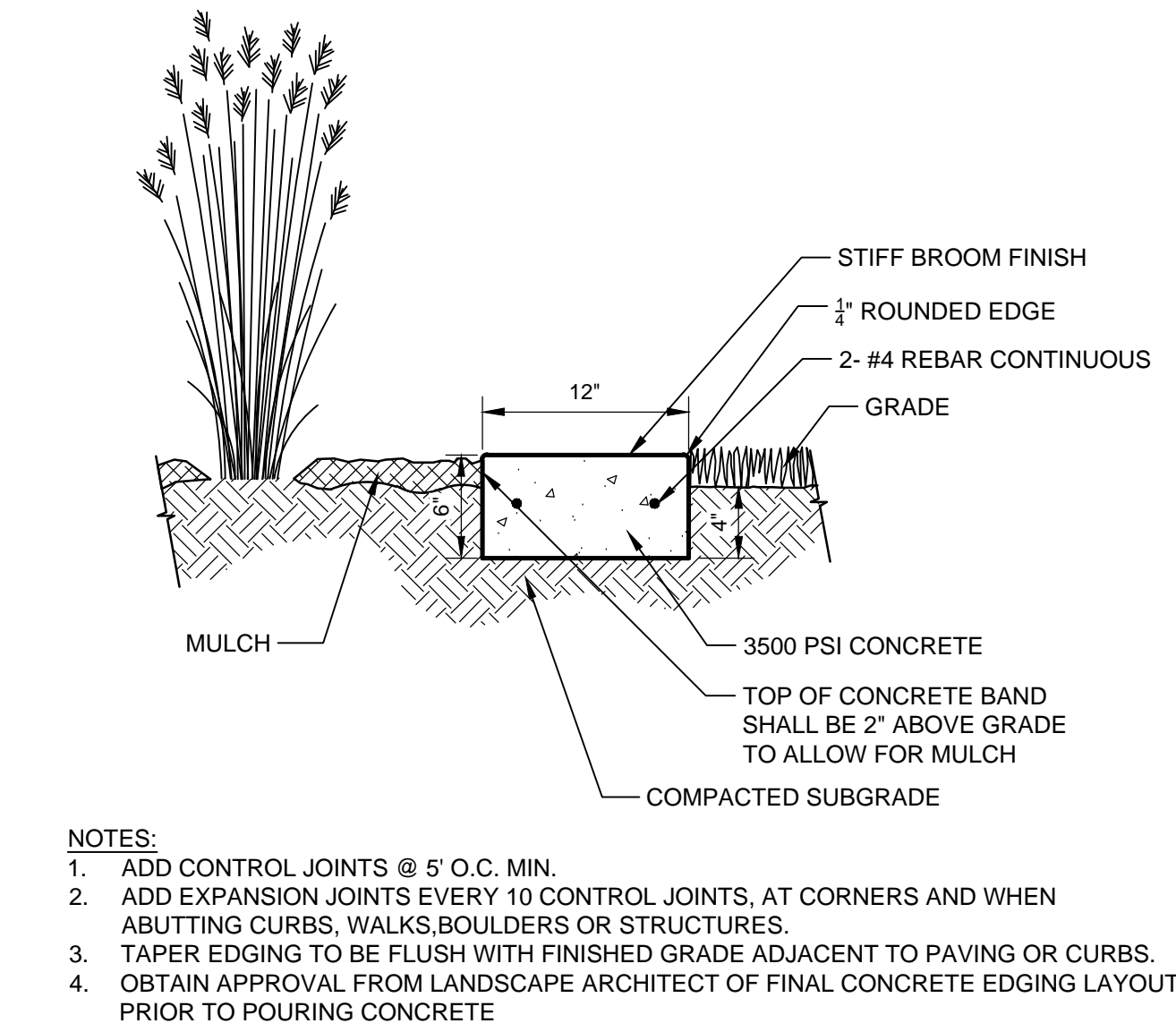

16 CONCRETE EDGING 6"X12"

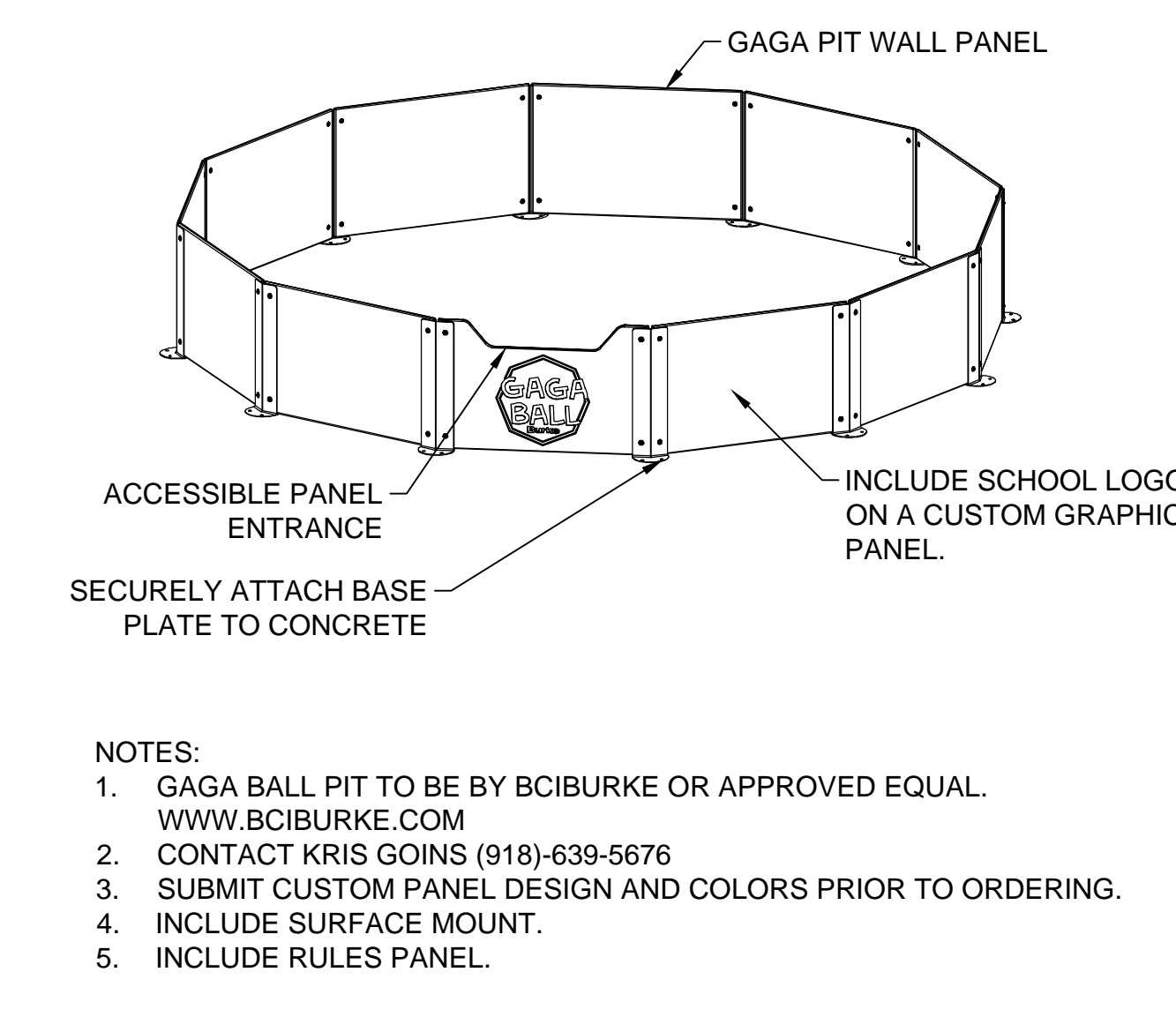

17 GAGA BALL PIT

LOCAL FILE: 7/1/2021 12:05:27 PM  
PLOT DATE: 20-1457-E883  
LWPB JOB: LWPB 2019.0002  
TEMPLATE:

BEFORE YOU DIG CALL FIRST  
THE CONTRACTOR SHALL BE RESPONSIBLE FOR THE SAFETY OF ALL UTILITIES, PUBLIC OR PRIVATE, DURING CONSTRUCTION AND WILL SATISFY HIMSELF AS TO THEIR ACTUAL LOCATION PRIOR TO CONSTRUCTION. HE WILL NOTIFY THE UTILITY OWNERS OF ACTUAL TIMES OF CONSTRUCTION TO ALLOW THEIR PARTICIPATION.

**CL**  
Landscape Architects  
825 N. Broadway, Suite 315  
Oklahoma City, OK 73102  
405-525-2200  
www.LandscapebyCL.com

# THE LAUNCHPAD



2021 BOND ISSUE PROJECT  
OAKDALE PUBLIC SCHOOLS



# CONCEPTUAL RENDERINGS

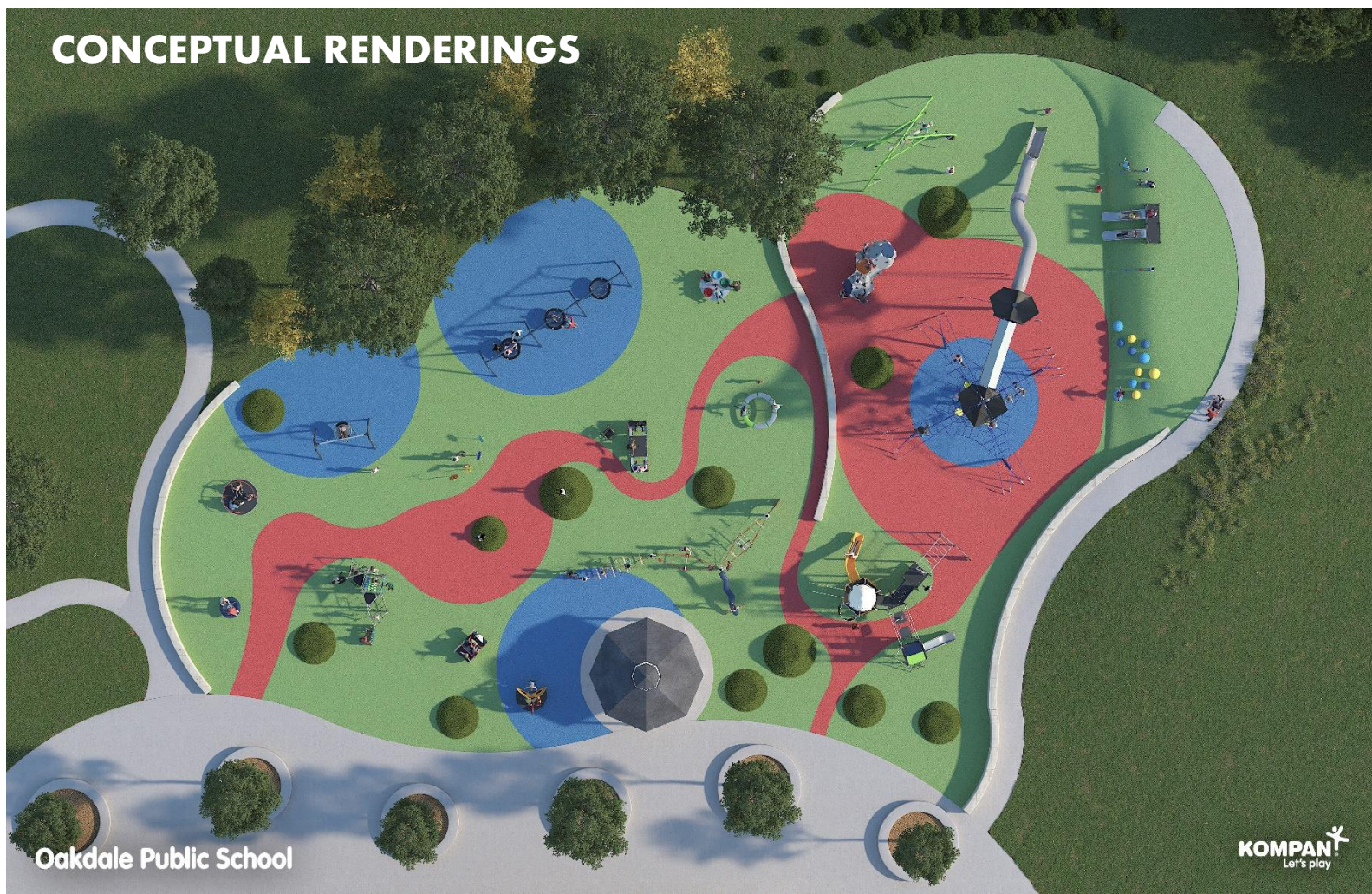

Oakdale Public School



Oakdale Public School



# CONCEPTUAL RENDERINGS



Oakdale Public School



Oakdale Public School



# CONCEPTUAL RENDERINGS



Oakdale Public School

KOMPAN!  
Let's play



Oakdale Public School

KOMPAN!  
Let's play

# CONCEPTUAL RENDERINGS



Oakdale Public School

**KOMPAK!**  
Let's play

POURED IN PLACE PLAYGROUND SURFACING



ARTIFICIAL TURF PLAYGROUND SURFACING

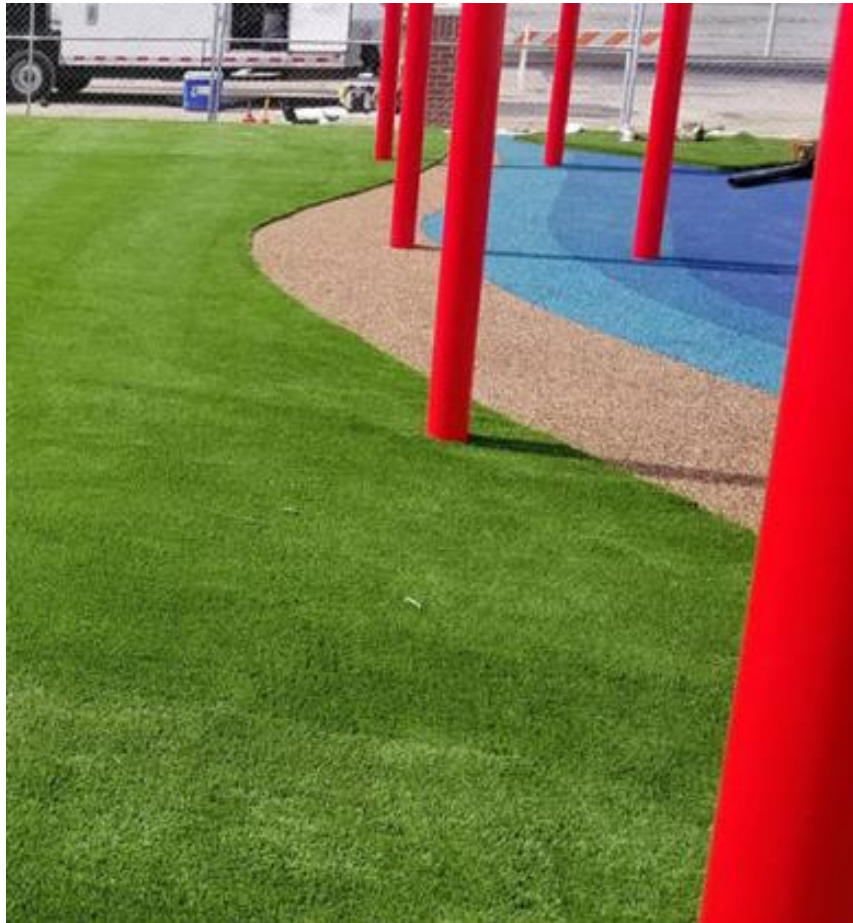



**CIRCULAR PAVER PATTERN**



**STABILIZED DECOMPOSED GRANITE**



**RUBY SPAR DECORATIVE BOULDERS**



DECORATIVE FENCE



AMPHITHEATER



ELECTRICAL PEDESTAL



MULTIPURPOSE SPORTS COURTS (BASKETBALL, PICKLEBALL, FOURSQUARE)



SOCCER GOAL/FIELD



GAGA BALL

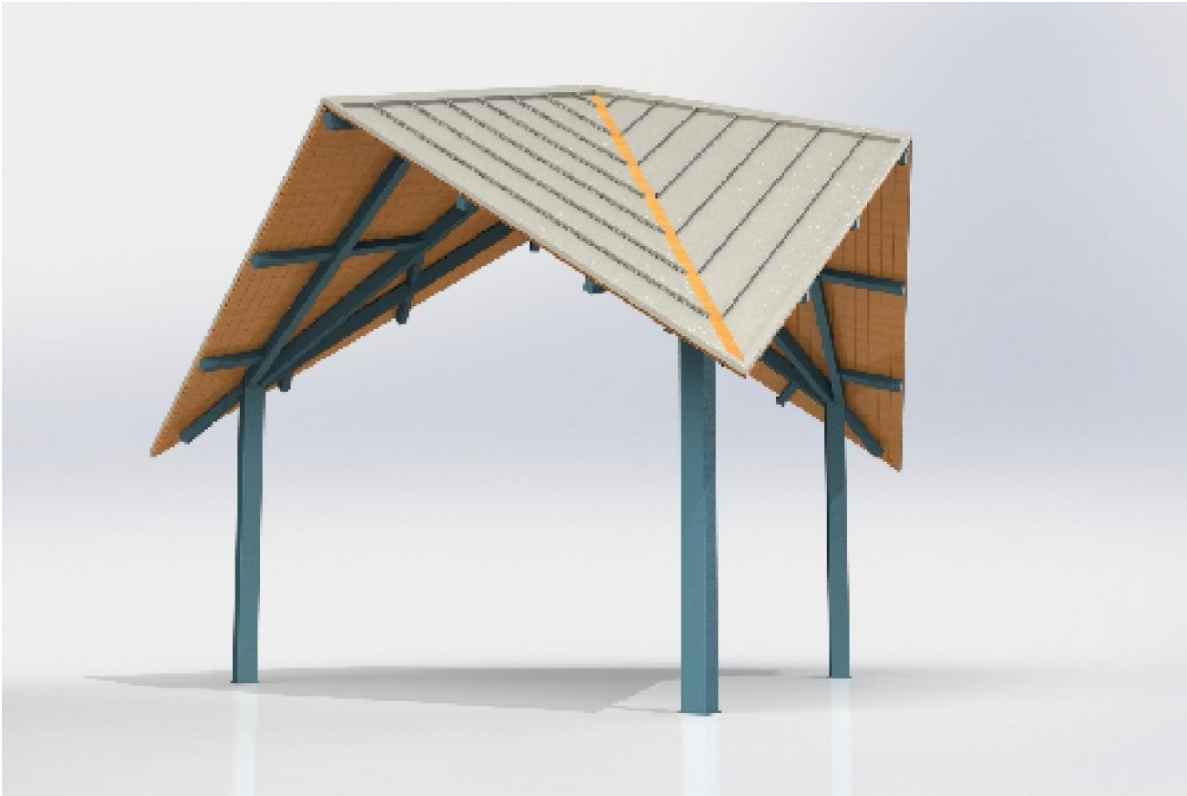

LARGE SHELTER



SMALL SHELTER (WITHOUT RAILING)



BENCH WITH OR WITHOUT BACK



MULTIPURPOSE COURT BENCH



TABLE



7 SPACE BIKE RACK

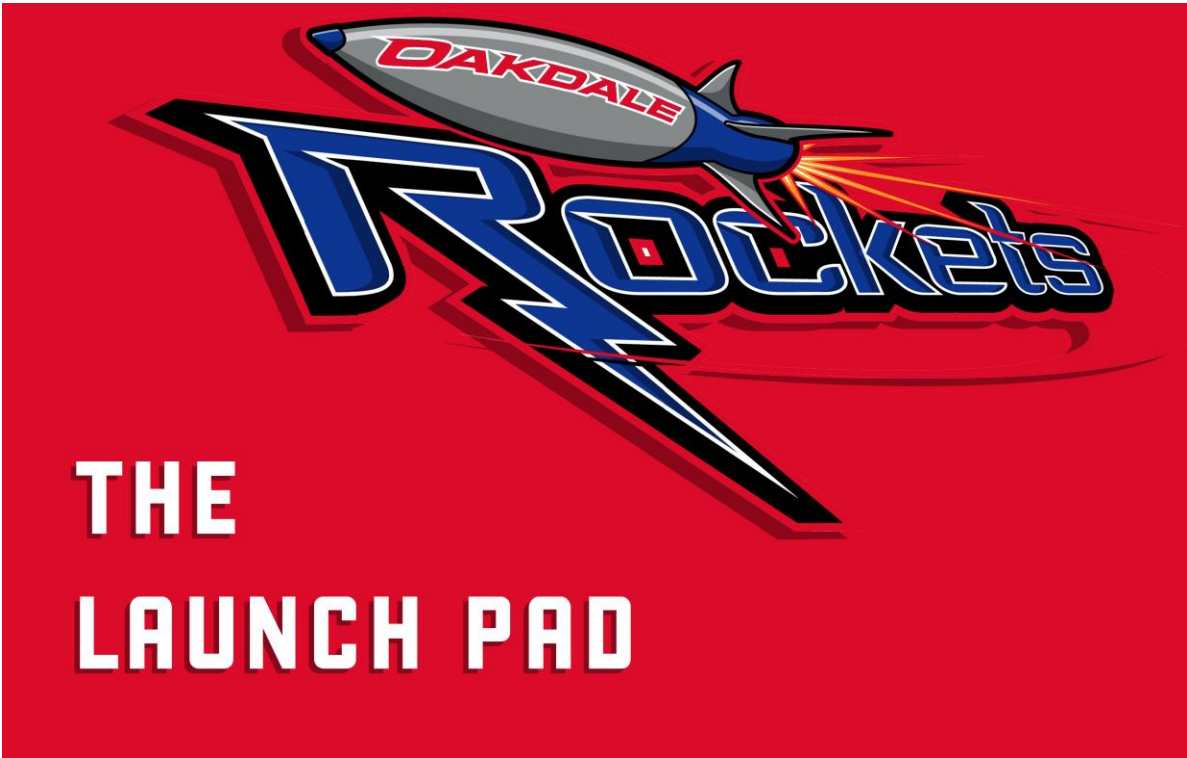

ENTRY SIGN

## Letter of Agreement

Date: July 20, 2021

Owner: Oakdale Public Schools  
10901 N. Sooner Road  
Edmond, OK 73013-8301

Architect: LWPB Architecture  
5909 NW Expressway, Suite 600  
Oklahoma City, OK 73132

Project: 2021 Master Plan

Architect shall:

1. Tour buildings and evaluate existing program. Meet with designated staff to discuss opinions of needs and future remodeling or expansion. Include food service, transportation and athletics.
2. Evaluate architectural items i.e. code constraints, ADA, safety, building physical condition, etc.
3. Review site conditions such as parking, queuing and drainage.
4. Develop a list of needs and solutions.
5. For new spaces, develop Programs of Spaces.
6. Prepare preliminary design sketches where needed to help determine cost and feasibility of new facilities or remodeling.
7. Incorporate enrollment analysis (from demographer).
8. Assist in assigning priorities based on information received and evaluated.
9. Develop preliminary timeline based on bond funds available.
10. Meet with Administration and/or staff to develop preliminary draft.
11. Assist in developing final 5-year master plan document to present to the Board.

Owner shall:

1. Examine documents and questions submitted by the Architect and promptly render decisions.
2. Provide student enrollment for at least the last 5 years to demographer (taken on the same date every year).
3. Provide transportation and technology information for inclusion.
4. Provide valuation projections from financial planner.
5. Provide potential land purchase options from real estate consultant, as needed.

Payment:

1. Compensation to the Architect shall be per the following phases:
  - a) \$13,000 at the completion of items 1 through 9 above.
  - b) \$3,000 at the completion of items 10 and 11 above.
  - c) Architect to solicit demographic analysis services (to be paid direct by Owner).
2. Statement of fees due will be itemized to the Owner at the end of each phase.
3. The Owner will make payment within 30 days.

OWNER

ARCHITECT



---

Oakdale Public Schools  
10901 North Sooner Rd.  
Edmond, OK 73013

---

LWPB, P.C.  
5909 NW Expressway, Suite 600  
Oklahoma City, OK 73132



Formerly Templeton Demographics

## 2021 Demographic Study

June 23, 2021

Oakdale Public School  
Dr. Joe Pierce  
10901 N. Sooner Rd  
Edmond, Ok 73013-8301

Zonda Intelligence, a Delaware Corporation (formerly Templeton Demographics) will provide the following demographic services:

### Demographic Study

- Analyze existing demographics and enrollment history for all attendance levels.
- Provide ten-year enrollment forecast by campus and grade level.
- Geo-code student database to assess current attendance patterns.
- Review single family and multi-family building patterns.
- Housing research including new starts, closings, developed vacant lots and future lots.
- Future and existing multifamily tracking.
- Single family and multifamily yield analysis.
- Deed transaction report and analysis.
- 1 review meeting and 1 board presentation



**Fee Schedule**

The fee for Demographic Services is \$10,000.00 for Oakdale Public Schools.

Invoice will be sent within 30 days of receiving this signed contract.

Completed report will be provided electronically.

**Please remit payment to**  
Zonda Intelligence  
P.O. Box 846075  
Los Angeles, CA 90084-6075

If the listed services are acceptable, **please sign** in the space below, at which time this letter will be our agreement concerning the demographic services.

We look forward to working with your administrative team.

Respectfully submitted,

A handwritten signature in black ink, appearing to read 'Bob Templeton', written in a cursive style.

Bob Templeton  
Vice President, Zonda Education  
btempleton@zondahome.com  
817-909-4194

I accept and agree to the contract for demographic services:

Signed by: \_\_\_\_\_

Date: \_\_\_\_\_

# SECTION E

July 2021  
Review

**SCHOOL HOURS**

The school year shall consist of not less than one thousand eighty (1,080) hours of classroom instruction. Not more than thirty (30) of these hours shall be used for professional meetings. In addition, parent-teacher conferences may be held during the school day and counted as classroom instruction for no more than six (6) hours per semester, for a total of twelve (12) hours per school year.

Notification of this policy shall be provided to the State Board of Education prior to October 15 of the applicable school year.

REFERENCE: 70 O.S. §1-109

No changes needed until 2022-23  
(SBE moved waiver requirements)

SCHOOL LIBRARY MEDIA CENTER

It is the policy of the Oakdale Board of Education that efforts be made to staff and maintain a school library media center adequate for the needs of students and teachers.

The superintendent is directed to develop regulations governing the selection of materials for and the use of the library media center.

*See* →

DRAFT

## SCHOOL LIBRARY MEDIA CENTER SELECTION OF MATERIALS (REGULATION)

The responsibility for the selection of library media center materials rests with the Oakdale Board of Education. Authority for the selection of proper materials shall be delegated to the library media center staff. Materials shall be selected in accordance with the principles established by the School Library Bill of Rights as approved by the American Association of School Librarians. Final selection will be made by the media specialist subject to approval by the board. Suggestions from the administration, the faculty, and from the students are encouraged.

The superintendent shall prepare regulations that support this policy.

The board of education and the media staff of the Stillwater Public Schools subscribe in principle to the following statement of policy expressed by the American Association of School Librarians:

### BILL OF RIGHTS FOR LIBRARY MEDIA CENTER PROGRAMS

The professional staff of school media centers is concerned with the development of informed and responsible citizens. To this end, the American Association of School Librarians reaffirms the Library Bill of Rights of the American Library Association and asserts that the responsibility of the school media center is:

To provide materials that will enrich the student as an individual and support the curriculum, taking into consideration individual needs, and the varied interests, abilities, socioeconomic backgrounds, and maturity levels of the student served.

To provide materials that will stimulate growth in knowledge and develop literary, cultural, and aesthetic appreciations and ethical standards.

To provide materials on all sides of issues, beliefs, and ideas so that young citizens may develop the habit of critical thinking, reading, listening, and viewing, thereby enabling them to develop an intellectual integrity in forming judgments.

To provide materials which accurately reflect all religious, social, political, and ethnic groups, and their contributions to our American heritage as well as knowledge and appreciation of world history and culture.

To provide a comprehensive collection of instructional materials which, when selected in compliance with basic selection principles, can be defended on the basis of their appropriateness for the users of the media center.

#### Responsibility for Selection

The board of education, the governing body of the school district, is legally responsible for the selection of instructional materials. This authority is delegated to the professional personnel of the district for the selection of these materials.

Materials for the library media center are selected primarily by the librarian with input from the Review Committee.

**SCHOOL LIBRARY MEDIA CENTER, SELECTION  
OF MATERIALS, REGULATION (Cont.)**Review Committee

Library Media Specialist  
Principal  
Counselor  
Classroom Teacher

*Add Parent  
rep?*

This committee must be approved by the superintendent.

Types of Material for Purchase

1. Instructional materials are chosen because they are of interest and have learning value for the student in the community. Materials are not excluded because of race, nationality, religion, or political views of the writer.
2. Insofar as it is practical, materials are provided which present all points of view concerning the problems and issues of our time: international, national, and local. Books and materials of sound factual authority are not removed or banned from library media center shelves because of partisan or doctrinal disapproval.
3. Periodicals and newspapers that supplement the curriculum needs shall be chosen for accuracy, objectivity, accessibility, demand, and prices.
4. Multiple items of outstanding quality and much in demand media are purchased as needed.
5. Nonfiction subjects that are topics of criticism are carefully considered before selection. Among these are:
  - A. Religion -- Factual unbiased material that represents all major religions may be included in the library media center collection. Bibles and other sacred writings are acceptable. Publications from religious bodies may be selected if they have general value or appear in magazine indexes.
  - B. Ideologies -- The library media center should, without making any effort to sway the reader's judgment, make available basic factual information on the maturity level of its reading public of ideologies or philosophies that are of current or continuing interest.
  - C. Science -- Medical and scientific knowledge suitable to the development stage of the student should be made available without any biased selection of facts.

Criteria for Selection

1. Selections are made for, and in accordance with, the different maturity levels of the students.
2. Materials are selected which fill a need related to the curriculum and/or contribute to the development and enrichment of the student.

**SCHOOL LIBRARY MEDIA CENTER, SELECTION  
OF MATERIALS, REGULATION (Cont.)**

3. Interests, needs, abilities of the students, and correlation of materials with the curriculum are dominating factors in the selection of materials.

Criteria for Evaluation

1. The author or producer should be qualified as a subject specialist.
2. Concepts, content, and vocabulary should be appropriate for the potential user.
3. Facts presented should be accurate and up-to-date.
4. Information should be logically arranged.
5. Subject matter should hold the attention of the student.
6. Format of the material should be attractive and durable.
7. Illustrations should be pertinent and well executed.
8. Each medium should meet a real or potential need.
9. Evaluation from standard selection aids should be given consideration.

Selection Tools

In selecting materials for purchase, the media specialist evaluates the existing collection and consults reputable, unbiased, professionally prepared selection aids, such as:

Booklist  
Bulletin of the Center for Children's Books  
Children's Catalog  
The Elementary School Library Collection  
Hornbook  
Oklahoma Department of Libraries Book  
School Library Journal  
Junior High & Senior High School Catalog  
Fiction Catalog

When possible, audiovisual materials shall be previewed before purchase or ordered with return privilege guaranteed.

**SCHOOL LIBRARY MEDIA CENTER, SELECTION OF MATERIALS, REGULATION (Cont.)**Gift Books and Materials

1. Gift books and materials are accepted with the understanding that they must meet the same selection criteria as materials purchased with board of education funds. The practice of a donor's purchasing new books or materials as library media center gifts is discouraged. It is preferable that donors make monetary gifts for the purchase of books and materials because the school receives a discount and can purchase more books for the same amount of money.
2. Gift books and other materials, once accepted by the Oakdale Public Schools, become the property of the Oakdale Public Schools.

Procedures for Reconsideration of Materials

It is recommended that a student or the student's parent should have this right to reject the use of library media center materials which seem incompatible with the student's values or beliefs. It is further recommended that classroom assignments involving library media center materials **provide for alternative choices**. This procedure is consistent with the National Council of Teachers of English Statement on Students' Right to Read, which is endorsed in its entirety. **However, no parent has the right to determine the reading matter for students other than his/her own children. Books and other materials shall not be removed or banned solely because of partisan or doctrinal disapproval.**

If an objection to a selection is made by the public, the procedures are as follows:

Be courteous and inform the patron of the process of media review. Make no commitments.

Invite the complainant to file his/her objections in writing on forms provided through the principal's office.

Completed forms are to be returned to the principal.

An informal conference with the principal will be held.

If unable to satisfy the complainant, refer the complaint to the Review Committee.

Material is not to be withdrawn without referring to the Review Committee, which determines whether the material should be withdrawn.

Material is reviewed and judged by this committee as to conformity with selection criteria and instructional goals.

The decision of the committee is submitted to the complainant and a file of the objection and decision is kept by the library media specialist and the principal.

**SCHOOL LIBRARY MEDIA CENTER, SELECTION  
OF MATERIALS, REGULATION (Cont.)**

In the event that the complainant does not accept the decision of the Review Committee, he/she may appeal to the board of education through the superintendent.

Final decision rests with the board of education.

Weeding and Discarding

Worn or missing standard items will be replaced periodically.

Out-of-date or no longer useful media are withdrawn from the collection.

Definition of Critical Terms

Selection -- the act or process of selecting materials.

Instructional Materials -- materials that fill a need related to the curriculum or contribute to the development and enrichment of the student. Evaluation -- to examine and judge the quality of materials.

Inquiry -- an information request, usually informal, that seeks to determine the rationale behind the presence of a particular item in a collection.

Expression of Concern -- an inquiry that has judgmental overtones. The inquirer has already made a value judgment on the material in question.

Complaint -- an oral charge against the presence and/or appropriateness of the material in question.

Challenge -- a formal written complaint filed with the library media center questioning the presence and/or appropriateness of specific material.

Attack -- a publicly worded statement questioning the value of the material, presented to the media and/or others outside the library media center organization, in order to gain public support for further action.

Censorship -- the removal of material from open access by any governing authority or its representative (boards of education/trustees, principals/library media center directors, etc.).

## BASIC INSTRUCTIONAL PROGRAM

The Oakdale Board of Education will provide reasonable educational opportunities to enable all children to succeed, both personally and as citizens.

Instructional programs will be developed with the view toward maintaining a balanced curriculum which will serve the general academic needs of all school-aged children and provide opportunities for individual children to develop specific talents and interests.

The board will encourage and support the professional staff in its efforts to investigate new curricular ideas, develop and improve programs, and evaluate results.

The board will appoint a committee composed of administrators, teachers, and parents to annually evaluate the curriculum to determine whether each child in the school system is receiving basic skill instructions.

The committee shall have access to all materials pertaining to the school curriculum, class schedules, and other information as long as the materials are not confidential or personal information. Members of the committee may visit with other staff members, students, former graduates, parents, and business people in the community for input into their evaluation.

The committee chairperson shall prepare a written report of the findings of the committee to the superintendent prior to the first day of February each year. This report should list the strengths and recommendations for each basic skill area.

The superintendent shall present the report to the board of education at a regular or special meeting. The board will consider each recommendation made by the committee. Any changes in methods of instruction, scheduling, or curriculum changes will be left entirely up to the superintendent and the board of education.

This committee shall be appointed to serve for a one-year term. However, individual members may be appointed to succeed themselves if the board so desires.

At all levels, provisions will be made for a wide range of individual differences through use of a variety of materials, adjustment in studies, and modified courses.

In all instances, the curriculum will meet the educational requirements established by state law.

The goals of the evaluation committee will be to permit and assist every child to acquire the following:

1. An understanding of himself and of his worth as an individual and a member of society.
2. A mastery of the basic skills in the use of the language arts -- listening, speaking, writing, reading, spelling, and grammar.
3. A mastery of mathematics for obtaining information, communicating effectively, thinking critically, reasoning logically, and solving problems.

**BASIC INSTRUCTIONAL PROGRAM (Cont.)**

4. Basic understanding of the principles of the natural, physical, biological, and social sciences and current events.
5. The desire and the ability to express himself creatively in one or more of the fine and creative arts and to appreciate the aesthetic expressions found in the art of others.
6. The attitudes associated with responsible citizenship for effective participation in the community, the state, the nation, and the world.
7. An understanding of career roles and how to relate learning experiences to real life.

**REFERENCE:** 70 O.S. §11-103

(Required)

## PARENT PARTICIPATION IN THE SCHOOL DISTRICT

The Oakdale Board of Education, in consultation with parents, teachers, and administrators, has developed and adopted this policy to promote and encourage the involvement of parents and guardians of children within the school district.

1. Parent participation in the schools is encouraged to improve parent and teacher cooperation in such areas as homework, attendance and discipline. At the beginning of each school year each teacher shall provide parents with contact information so that a parent has the opportunity to contact the teacher or administration to address concerns related to homework, attendance and discipline. This can be achieved through the school student accounting system, currently TeacherEase, ~~or a school app, currently School Way~~, or other electronic or hard copy methods.
  2. Parents may request additional information from the administration to learn about the course of study for their children and review learning materials, including the source of any supplemental educational materials. This can be achieved through the posting of class / grade syllabi and access to student assignments through the student accounting system e-mail and/or hard copy communication with parents.
  3. **Parents who object to any learning material or activity on the basis that it is harmful may withdraw their children from the activity or from the class or program in which the material is used. Objection to a learning material or activity on the basis that it is harmful includes objection to a material or activity because it questions beliefs or practices in sex, morality or religion. Parents are hereby informed that the withdrawal of a child from any state mandated courses could prevent their child from being eligible to receive a high school diploma.** The request for withdrawal must be in writing and the teacher will have the option of assigning another assignment to the student.
  4. If the school district offers any sex education curricula pursuant to Section 11-105.1 of Title 70 of the Oklahoma Statutes or pursuant to any rules adopted by the State Board of Education, parents may opt their child out of sex education instruction if the child's parent provides written objection to the child's participation in the sex education curricula. The request for withdrawal must be in writing and the teacher will have the option of assigning another assignment to the student.
  5. Parents are hereby notified and given the opportunity to withdraw their children from any instruction or presentations regarding sexuality in courses other than formal sex education curricula pursuant to Section 11-105.1 of Title 70 of the Oklahoma Statutes;
  6. Parents may learn about the nature and purpose of **clubs and** activities that are part of the school curriculum, as well as extracurricular clubs and activities that have been approved by the school. A list of school clubs that have been approved by the board of education is available from the administration upon request. These approved clubs and activities include Builders Club and STEM opportunities. These clubs and activities may have the required information posted on the school web site.
1. Specific parent rights and responsibilities provided under the laws of this state, include the following:
    - a. the right to opt out of a sex education curriculum if one is provided by the school district.
    - b. open enrollment rights.
    - c. the right to opt out of assignments for specified reasons and following specified procedures (item #3).
    - d. the right to be exempt from the immunization laws of the state pursuant to Section 1210.192 of Title 70 of the Oklahoma Statutes,
    - e. the promotion requirements prescribed in Section 1210.S08E of Title 70 of the Oklahoma Statues,

## PARENT PARTICIPATION IN THE SCHOOL DISTRICT (Cont.)

- f. the minimum course of study and competency requirements for graduation from high school prescribed in Section 11-103.6 of Title 70 of the Oklahoma Statutes,
- g. the right to opt out of instruction on the acquired immune deficiency syndrome pursuant to Section **11-103.3** of Title 70 of the Oklahoma Statutes,
- h. the right to review test results,
- i. the right to participate in gifted programs pursuant to Sections 1210.301 through 1210.308 of Title 70 of the Oklahoma Statutes,
- j. the right to inspect instructional materials used in connection with any research experimentation program or project pursuant to Section 11-106 of Title 70 of the Oklahoma Statutes,
- k. the right to receive a school report card,
- l. the attendance requirements prescribed in Section 10-106 of Title 70 of the Oklahoma Statutes,
- m. the right to public review of courses of study and textbooks,
- n. the right to be excused from school attendance for religious purposes,
- o. policies related to parental involvement pursuant to this section,
- p. the right to participate in parent-teacher associations and organizations that are sanctioned by the board of education of a school district, and
- q. the right to opt out of any data collection instrument at the district level that would capture data for inclusion in the state longitudinal student data system except what is necessary and essential for establishing a student's public school record.

Parents may submit a written request for information during regular business hours to either the school principal at the school site or the superintendent at the office of the school district. Within ten (10) days of receiving the request for information, the school principal or superintendent, shall deliver the requested information to the parent or provide a written explanation of the reasons for the denial of the requested information. If the request is denied or the parent does not receive the requested information within fifteen (15) days after submitting the request, the parent may submit a written request for the information to the board of education. The board of education shall formally consider the request at the next scheduled public meeting if the request can be properly noticed on the agenda. If the request cannot be properly noticed on the agenda, the board of education shall formally consider the request at the next subsequent meeting of the board of education. All information provided may be in either hard copy or electronic format.

Ref:

\* Okla. Parents Bill of Rights

SPECIAL EDUCATION

It is the policy of this school district to provide special education to all exceptional children who reside in the school district. This duty will be satisfied by (use one or more of the following):

- [ the district directly providing special education for such children. ]
- [ the district joining in a cooperative program with another district or districts to provide special education for such children. ]
- [ the district joining in a cooperative program with a private or public institution within such district to provide special education for children who are deaf or hard-of-hearing, or for children who are blind or partially blind. ]
- [ transferring certified exceptional children to other school districts that accept them and provide special education for such children, with the district in which the child resides paying tuition therefor as hereinafter provided. ]

Add Later if needed

Prior to July 1, 1990, exceptional children shall mean educable mentally handicapped children, trainable mentally retarded children, speech-defective children, emotionally disturbed or perceptually handicapped children, children with special health problems, children requiring the services of a visiting counselor, children with special learning disabilities as a result of neurological impairment, multiple-handicapped children, and other handicapped children of four years of age as of the first day of September of the school year, and on and after July 1, 1990 of three years of age; provided up to July 1, 1991, that there shall be no set minimum age for blind children, partially blind children, deaf and hard-of-hearing children, and low incidence severely multiple-handicapped children, i.e., deaf-blind, retarded-cerebral palsied, autistic, and other children failing to thrive.

Provided, on and after July 1, 1991, children from age birth through two years (0-24 months) of age who meet the eligibility criteria specified in Section 3 of the Oklahoma Early Intervention Act, shall be served pursuant to the provisions of the Oklahoma Early Intervention Act; further provided that any children served shall be bona fide residents of this state, whose conditions are such that it is impractical or impossible for them to benefit from or participate in the regular classroom program of the public schools in the district in which they reside and whose education requires a modification of the classroom program. Provided, that the attendance of said children in special education classes shall be included in the average daily attendance computations for State Aid purposes.

If valid and reliable testing and full and individual evaluation materials appear to have led to the overrepresentation of students who are members of a particular race, national origin or cultural group in any special education category, then the school district shall conduct a thorough self-evaluation in order to determine:

1. Whether additional or substitute materials and procedures, which have at least equal predictive validity, but do not have such an adverse effect on members of a particular racial, national origin or cultural group, can be identified.
2. Whether any of the following resulted in racial or cultural bias:
  - a) The use of tests with inherent content and/or language bias;
  - b) The use of tests that lack validity for a group of persons with whom or the purposes for which they are used;

**SPECIAL EDUCATION (Con't)**

- c) The use of tests that lack reliability for a group of persons with whom they are used;
- d) The presence of culturally and linguistically incompetent test administration;
- e) Student unfamiliarity with test behaviors and assumptions;
- f) Student discomfort with the test administrator and/or testing environment;
- g) Lack of student motivation to perform well; and/or
- h) The failure to integrate full and individual evaluation information from multiple sources and/or to reconcile inconsistent or conflicting full and individual evaluation results.

The school district will utilize the policies and procedures for Special Education Services set forth by the Oklahoma State Department of Education.

**REFERENCE:** 70 O.S. §1-107  
70 O.S. §13-101 through §13-113  
70 O.S. §18-109.5  
Individuals With Disabilities Education Act, 20 USC §1400, et seq.

## SPECIAL EDUCATION SERVICES FOR CHILDREN ENROLLED IN PRIVATE SCHOOL

The school district shall provide special education services for district resident children enrolled in private schools located within the school district in accordance with state and federal law requirements. To ensure timely and meaningful consultation, the superintendent or designee shall consult with private school officials to design and develop educational programs and services. Consultation shall include:

- A. How the children's needs will be identified;
- B. What services will be offered;
- C. How, where and by whom the services will be provided;
- D. How the services will be academically assessed and how the results of that assessment will be used to improve those services;
- E. The size and scope of the equitable services to be provided to the eligible private school children, the proportion of funds that are allocated under federal law for the services;
- F. The method and sources of data that are utilized to determine the number of children from low-income families in participating school attendance areas who attend private schools;
- G. How and when the school will make decisions about the delivery of services to such children, including a thorough consideration and analysis of the views of the private school officials on the provision of services through a contract with potential third-party providers;
- H. How, if the school and the private school officials disagree on the provision of services through a contract, the school will provide in writing to the private school officials an analysis of the reasons why a contractor was not utilized;
- I. Whether the school will provide services directly or through a separate government agency, consortium, entity, or third-party contractor;
- J. Whether to provide equitable services to eligible private school children:
  - a. By creating a pool or pools of funds with all of the funds allocated by federal law based upon all the children from low-income families in a participating school attendance area who attend private schools; or
  - b. By using a proportion of funds allocated under federal law based upon the number of children from low-income families in the school district's participating school attendance area who attend private schools.
- K. When, including the approximate time of day, services will be provided; and
- L. Whether to consolidate and use funds provided under federal law in coordination with eligible funds available for services to private school children under applicable programs defined in federal law to provide services to eligible private school children participating in programs.

If the school district disagrees with the private school regarding an issue addressed above, the school district shall provide in writing to private school officials the reasons why the school district disagrees. The school district will maintain written documentation which includes a written affirmation signed by private school officials that consultation has occurred. The written affirmation shall also include an option for private school officials to provide that the private school officials do not believe that timely and meaningful consultation has occurred and that the program design is not equitable with regard to private school students.

**LEGAL REFERENCE:**      **ESSA Section 1117**

SECTION E: Part 2

**LIMITED ENGLISH PROFICIENCY INSTRUCTION**

The Board of Education will provide a program of language instruction to students who have limited English proficiency. Student participation in any language instruction program or instruction in English as a second language is voluntary and requires written parental permission.

Students who meet any one or more of the following criteria shall be identified as being limited in English proficiency:

A student who:

1. Was not born in the United States or whose native language is a language other than English and comes from an environment where a language other than English is dominant;  
or
2. Is a Native American or Alaskan Native or who is a native resident of the outlying areas and comes from an environment where a language other than English has had a significant impact on the student's level of English language proficiency;  
or
3. Is migratory and whose native language is other than English and comes from an environment where a language other than English is dominant;  
and
4. Who has sufficient difficulty speaking, reading, writing, or understanding the English language and whose difficulties may deny such individual the opportunity to learn successfully in classrooms where the language of instruction is English or to participate fully in our society.

Tutorial Programs

Students who are certified to receive educational services through the State Migrant Education Department in cooperation with the State Department of Education are offered 30-minute tutorial help during the school day in the areas of reading, math, and language arts. Criteria for eligibility include students who have moved into a district within the last six years from another district or state and whose parents seek either seasonal or temporary employment in agriculture.

No Child Left Behind Act of 2001

If this district receives federal funding for Limited English Proficient (LEP) Programs, the following will be provided:

1. Parents will be notified of their student's placement in a language program and their options associated with that placement. Notification will include the reasons for identifying the child as LEP and the reasons for placing the child in the specified program.

**LIMITED ENGLISH PROFICIENCY INSTRUCTION (Cont.)**

2. Students will participate in regular assessments in a manner that will yield an accurate assessment. (See also policy EK.) Test waivers may be granted on a case-by-case basis for LEP students who demonstrate unusual and unique circumstances; however, students who have been educated in the United States for three years are required to participate in reading/language arts assessment in English.
3. Certification that teachers in the program are fluent in English as well as other languages used in instruction (if the district receives subgrants).
4. Evaluation of the program and the academic success and language achievement of the students in the program. Parents will be notified of:
  - A. Their child's level of English proficiency and how such a level was assessed.
  - B. The status of their child's academic achievement.
  - C. The method of instruction used in the program in which the child is placed, and the methods of instruction used in other available programs.
  - D. Information as to how the program will meet their child's educational strengths, assist him/her to learn English, and meet age-appropriate academic achievement standards.
  - E. Exit requirements for the program.
  - F. If the child has a disability, a statement as to how the LEP will meet the objectives of the child's IEP.

Consequences of inadequate yearly progress include notification of parents, development of improvement plans, and restructuring of programs or the district will lose federal funds.

For non-English speaking parents, the district will arrange to provide translations of this information in their native language.

**REFERENCE: ESSA Sections 3111-3116**

***THIS POLICY REQUIRED BY ESSA***

## EARLY CHILDHOOD EDUCATION PROGRAM

It is the policy of the Oakdale Board of Education to provide a voluntary Early Childhood Education Program for those children who are at least four years of age but not more than five years of age on or before September 1 free of charge.

The Early Childhood Education Program shall be at least two and one-half (2½) hours for half-day programs and shall be six (6) hours for full-day programs.

Children who are not residents of this district and who are at least four (4) years of age but not more than five (5) years of age on or before September 1 and have not attended kindergarten shall be enrolled in the Early Childhood Education Program upon payment of a tuition fee. The tuition fee for such nonresident children shall be based on the per capita cost of education for a similar period in the preceding year. This district may refuse to accept a nonresident child if the physical facilities or teaching personnel to accommodate the child in an early childhood education class are not available.

Any parent, guardian, person or institution, having care and custody of a child, who pays ad valorem tax on real property located in this district may enroll the child in the early childhood education program and receive tuition credit equal to the amount of the ad valorem tax paid in this district. Provided, the credit shall not exceed the total amount required for the tuition payment.

1. Offering a four-year-old Pre-K program is not a state mandate neither is there an attendance requirement.
2. To attend the Oakdale Public Schools' Pre-k program, a student must be at least four years old as of September 1 on the year of enrollment. Children who are five years old on September 1 of the year of enrollment may become students in the Pre-k program, but only if their fifth birthday occurs on or after June 1 of the year of enrollment.
3. Children who have previously been served in a public school pre-kindergarten program may not make application for an additional year.
4. The total enrollment of the Pre-K program will be 40 or less, unless additional sessions are opened under this policy. This number will be no greater than 20 students in the morning session and 20 students in the afternoon session.
  - a. If there are more than 10 students in a session a teacher's assistant will be in the classroom with the certified early childhood teacher.
    - i. Teacher's assistants will meet the NCLB guidelines *for employment.*
  - b. Morning Session
    - i. The morning session will begin at the same time as the beginning of school for all other students.
    - ii. Pre-K students may ride the bus available for the regular morning bus routes. *add spec/new line*
    - iii. The morning session will last a minimum of 2 ½ hours.
    - iv. Morning session Pre-K will not be provided school transportation to leave after the session ends.
  - c. Afternoon Session
    - i. Lunch is not available for pre-k students.
    - ii. Afternoon session Pre-K students will not be provided school transportation to the session.
    - iii. The afternoon session will begin 2 ½ hours before the end of the school day.
    - iv. The afternoon session will end at the same time as the ending of the school day for all other students.
    - v. Pre-K students may ride the bus used for the regular afternoon bus routes.

EARLY CHILDHOOD EDUCATION PROGRAM (Cont.)

- 5. Enrollment procedures for Pre-K students will be consistent with the school transfer and enrollment policies.
  - a. Enrollment forms will be taken starting the same day as other elementary enrollment forms before the next school year. Normally this will be the third Monday in April. *(3) TBA.*
  - b. Enrollment forms will be dated and numbered in the order they are received.
  - c. Enrollment forms will be turned into the school principal's office. *(online)*
  - d. All enrollment forms will be received but there is no guarantee of approval and placement into the Pre-K program. Acceptance of an enrollment form does not constitute acceptance into the Pre-K program.
  - e. For those approved, consideration will be given to their stated preference, but there will be no guarantee of enrollment in the a.m. or p.m. session.
  - f. Enrollment forms will be approved in the following manner:
    - i. District resident and transfer students who should be placed in PK, regardless of age, because of an educational IEP.
    - ii. District resident students ~~and~~ the children of District employees. *2 Add Rows.*
    - iii. Other students who may be eligible for transfer into the District under the District's Transfer Student Policy.
- ~~6. For purposes of this Policy only, a "District employee" means an employee who works at least 20 hours a week during the school year.~~
- 7. Nothing in this policy is meant to conflict with USDE requirements, Oklahoma statute, SDE guidelines, or accreditation procedures.
- 8. Upon school administration recommendation and school board approval, additional sessions of four-year-old Pre-K may be opened. If additional sessions of four-year-old pre-k are opened, enrollment form acceptance will be in conformity with this policy.

REFERENCE: 70 O.S. §11-103.7  
70 O.S. §1-114

*If oversubscribed, \_\_\_\_\_?*

Required if district  
serves 6th grade  
above.

## ALTERNATIVE EDUCATION

This school district shall provide an alternative education program that conforms to the requirements of state law and rules applicable to alternative education. The alternative education program shall conform to federal law requirements if federal funding is utilized to provide services to meet the educational needs of neglected, delinquent, and at-risk children and youth. The program shall:

1. Allow class sizes and student/teacher ratios conducive to effective learning for at-risk students;
2. Incorporate appropriate structure, curriculum, and interaction and reinforcement strategies designed to provide effective instruction;
3. Include an intake and screening process to determine eligibility of students;
4. Demonstrate that teaching faculty are appropriately licensed or certified teachers;
5. Demonstrate that teaching faculty have been selected on the basis of a record of successful work with at-risk students or personal and educational factors that qualify them for work with at-risk students;
6. Reflect appropriate collaborative efforts with state agencies and local agencies serving youth;
7. Provide courses that meet the academic curricula standards adopted by the State Board of Education and additional remedial courses;
8. Offer individualized instruction;
9. State clear and measurable program goals and objectives;
10. Include counseling and social services components with the provision that providers of services are not required to be certified as school counselors;
11. Require a plan leading to graduation be developed for each student in the program that will allow the student to participate in graduation exercises for the school district after meeting all of the graduation requirements of the school district.
12. Offer life skills instruction;
13. Provide opportunity for arts education to students, including Artists in Residence programs coordinated with the Oklahoma Arts Council;
14. Provide a proposed annual budget;
15. Include an evaluation component including an annual written self-evaluation;
16. Be appropriately designed to serve middle school, junior high school, and secondary school students in grades six through twelve who are most at risk of not completing a high school education for a reason other than as identified in 70 O.S. §13-10, and;

**ALTERNATIVE EDUCATION (Cont.)**

17. Allow all students in the alternative education program, who otherwise meet all of the participation requirements, to participate in vocational programs and extracurricular activities, including but not limited to athletics, band, and clubs.

The alternative education program shall be operational and serving students by September 15, of each school year.

Any equipment or material purchased by the school district with revenue received for students participating in an alternative education program shall be used only in or directly for the alternative education program offered by the district during the hours the alternative education program is in operation. The equipment or materials may be used for other purposes during hours when the alternative education program is not in operation.

If a program will serve fewer than ten (10) students, the alternative education program shall be offered by the district through an interlocal cooperative in which the district participates, unless the program has been granted a waiver from this requirement by the State Department of Education.

**REFERENCE:** 70 O.S. §1210.568  
70 O.S. §1210.569  
20 U.S.C. § 6434

**NOTE:** Referenced statute 70 O.S. §1210.568 requires the program be provided by all school districts beginning with the first semester of the 2000-2001 school year.

## PROMOTION AND RETENTION

The Oakdale Board of Education believes the primary goal of the educational process is to educate. The board also believes that since each child develops physically, mentally, emotionally, and socially at an individual rate, not all children will complete twelve grade levels of work at the same rate. Therefore, for some children, more than twelve years of public education are necessary to achieve the minimal standards of an appropriate education.

Students in special education are excluded from this policy and will be advanced or retained in accordance with their Individual Educational Program as created by their IEP team.

Grade level placement in the elementary and in the <sup>middle</sup> junior high school will be based upon the child's maturity (emotional, social, mental, and physical), chronological age, school attendance, effort, and marks achieved. Standardized test results can be used as one means of judging progress. The grade marks earned by the child throughout the year shall reflect the probable assignment for the coming year. Assignment of grade marks will not be used as a means of discipline or reward under any circumstances.

Whenever a teacher or a placement committee recommends that a student be retained at the present grade level or not receive a passing grade in a course; the parent(s) or guardian, if dissatisfied with the recommendation, may appeal the decision by complying with the district's appeal process. The decision of the board of education shall be final. The parent(s) or guardian may prepare a written statement to be placed in and become a part of the permanent record of the student stating the parent(s)'s or guardian's reason(s) for disagreeing with the decision of the board.

A grade mark on a report card at the end of the grading period shall not fulfill the teacher's responsibility in reporting a child's progress to the child's parent(s) or guardian. Informal notes and personal conferences are necessary to help the teacher and the parent(s) or guardian understand the child's development and progress. The parent(s) or guardian shall be informed, and a conference scheduled if the parent(s) or guardian desire, when it becomes apparent that a child may need to remain at a grade level.

Upon request of the student, or the student's parent(s) or guardian, a student who has been recommended for retention, is failing a grade, or seeks advancement will be given the opportunity to demonstrate proficiency in the Oklahoma Academic Standards (OAS) for the applicable grade level or course. Proficiency will be demonstrated by some means of assessment or evaluation appropriate to the curriculum area, for example: semester test, portfolio, criterion-referenced test, thesis, project, product, or performance. (See also policy EIAE.)

Students demonstrating proficiency in a set of competencies at the <sup>90-100%</sup> % level shall be advanced to the next level of study in the appropriate curriculum area(s). This decision will take into consideration such factors as social, emotional, physical, and mental growth. The school will confer with parents or guardians in making such promotion/acceleration decisions.

Elementary, middle level, or high school students may demonstrate proficiency in the OAS Outcomes for grades 9-12 high school curriculum areas. Appropriate notation will be placed on the high school transcript. The unit(s) shall count toward meeting the requirements for the high school diploma.

The superintendent is directed to establish a regulation containing criteria to be used by the administration in considering students for promotion or retention.

REFERENCE: 70 O.S. §24-114.1  
70 O.S. §11-103.6

## STUDENT RETENTION (REGULATION)

In accordance with the policy of the board of education, the following criteria for the selection of students to be retained in their current grade, or denied course credit, will be used in this school district.

Students shall be promoted or receive credit for a course of study if a grade average of 760% has been achieved for an entire course of study as determined by the teacher.

Students in grades one through eight must achieve a grade average of 760% or higher in at least three major courses of study to be promoted to the next higher grade. The major courses of study are math, language arts, science, reading, and social studies.

1. Any first-grade, second-grade, or third-grade student who demonstrates end of year proficiency in reading at the third-grade level through a screening instrument which meets the acquisition of reading skills criteria shall not be subject to retention. Upon demonstrating proficiency through screening, the district shall provide notification to the parent(s) and/or guardian(s) of the student that they have satisfied the requirements of the Reading Sufficiency Act and will not be subject to retention pursuant to this section.
2. If a third-grade student is identified at any point of the academic year as having a significant reading deficiency, which shall be defined as not meeting the grade level targets scoring below proficient on a screening instrument which meets the acquisition of reading skills criteria, the district shall immediately begin a student reading portfolio and shall provide notice to the parent of the deficiency.
3. If a student has not yet satisfied the proficiency requirements of this section prior to the completion of third grade and still has a significant reading deficiency, as identified based on assessments administered as required by law, has not accumulated evidence of third-grade proficiency through a student portfolio, or is not subject to a good cause exemption, then the student shall not be eligible for automatic promotion to fourth grade.
4. The minimum criteria for grade-level performance of third grade students pursuant to the Reading Sufficiency Act shall be that student are able to read and comprehend grade level text. To determine the promotion and retention of third grader students pursuant to the Reading Sufficiency Act, the State Board of Education shall use only the scores for reading foundations/processes and vocabulary portions of the statewide third-grade assessment and administered pursuant to Oklahoma law. The performance levels established by the Commission for Educational Quality and Accountability shall ensure that students meeting the performance-level criteria are performing at grade level on the reading foundations and vocabulary portions of the statewide third grade assessment.
5. ~~For the 2016-2017 school year, a student not eligible for automatic promotion under paragraph 3 of this subsection and who scores at the unsatisfactory level on the reading portion of the third-grade statewide criterion-referenced test, may be evaluated for "probationary promotion" by the Student Reading Proficiency Team. Beginning with the 2017-2018 school years, a student not eligible for automatic promotion as provided for under paragraph 3 of this subsection and who scores below the proficiency level do not meet the performance criteria established by the Commission for Educational Quality and Accountability on the reading portion of the statewide third-grade assessment may be evaluated for "probationary promotion" by the Student Reading Proficiency Team. The Student Reading Proficiency Team shall be composed of:~~
  - (1) the parent(s) and/or guardian(s) of the student,
  - (2) the teacher assigned to the student who had responsibility for reading instruction in that academic year,

**STUDENT RETENTION (Cont.)**

(3) a teacher who is responsible for reading instruction and is assigned to teach in the next grade level of the student, and

(4) a certified reading specialist if one is available.

The student shall be promoted to the fourth grade if the team members unanimously recommend "probationary promotion" to the school principal and the school district superintendent and the principal and the superintendent approve the recommendation that promotion is the best option for the student. If a student is allowed a "probationary promotion," the team shall continue to review the reading performance of the student and repeat the requirements of this paragraph each academic year until the student demonstrates grade-level reading proficiency, as identified through a screening instrument which meets the acquisition of reading skills criteria, for the corresponding grade level in which the student is enrolled or transitions to a locally designed remediation plan after the fifth grade which shall have the goal of ensuring that the student is on track to be college and career ready ~~the requirements set forth by the Achieving Classroom Excellence Act.~~

~~5.6. Students who do not meet the performance criteria established by the Commission for Educational Quality and Accountability score below the proficient level on the reading portion of the statewide third-grade assessment and who are not subject to a good cause exemption as provided in subsection K of this section, and who do not qualify for promotion or "probationary promotion" shall be retained in the third grade and provided intensive instructional services and supports.~~

~~6.7. The school district shall annually report to the State Department of Education the number of students promoted to the fourth grade as required by law.~~

A third-grade student may be promoted for "good cause" if the student meets one of the following statutory exemptions:

(1) ~~Limited English proficient~~ English language learner students who have had less than two years of instruction in an English language learner program;

(2) Students with disabilities whose individualized education plans, consistent with state law, indicates that the student is to be assessed with alternative achievement standards through the Oklahoma Alternate Assessment Program (OAAP);

(3) Students who demonstrate an acceptable level of performance on an alternative standardized reading assessment approved by the State Board of Education;

(4) Students who demonstrate through a student portfolio, that the student is reading on grade level as evidenced by demonstration of mastery of the state standards beyond the retention level;

(5) ~~Students with disabilities who participate in the statewide assessments and who have an individualized education plan that reflects that the student has received intensive remediation for reading and has made adequate progress in reading pursuant to the student's individualized education program for more than two years but still demonstrates a deficiency in reading and was previously retained in prekindergarten for academic reasons, kindergarten, first grade, second grade, or third grade; and~~

**STUDENT RETENTION (Cont.)**

(6) Students who have received intensive remediation in reading through a program of reading instruction for two or more years but still demonstrate a deficiency in reading and who were previously retained in prekindergarten for academic reasons, kindergarten, first grade, second grade, or third grade, and for a total of two years.

(7) Students who have been granted an exemption for medical emergencies by the State Department of Education.

Requests to exempt students from the mandatory retention requirements based on one of the good-cause exemptions shall be made using the following process:

1. Documentation submitted from the teacher of the student to the school principal that indicates the student meets one of the good-cause exemptions and promotion of the student is appropriate. Documentation shall be limited to the alternative assessment results or student portfolio work and the individual education plan (IEP), as applicable;
2. The principal of the school shall review and discuss the documentation with the teacher. If the principal determines that the student meets one of the good-cause exemptions and should be promoted based on the documentation provided, the principal shall make a recommendation in writing to the school district superintendent; and
3. After review, the school district superintendent shall accept or reject the recommendation of the principal in writing.

In the elementary and middle schools, a placement committee consisting of the principal, counselor, and teacher(s) shall determine if a student is to be assigned to the next higher grade. The committee shall consider standardized test scores and the student's age.

Whenever a teacher or a placement committee recommends that a student be retained at the present grade level or not passed in a course, the parent(s) or guardian, if dissatisfied with the recommendation, may appeal the decision by complying with the district's appeal process. The decision of the board of education shall be final. The parent(s) or guardian may prepare a written statement to be placed in and become a part of the permanent record of the student stating the parent(s)'s or guardian's reason(s) for disagreeing with the decision of the board.

**REFERENCE: 70 O.S. §24-114.1  
70 O.S. §1210.508C**

**MIDYEAR PROMOTION  
FOURTH-GRADE**

A student retained in third grade in accordance with the Reading Sufficiency Act may be eligible for a midyear promotion to fourth grade. The midyear promotion of a retained student will be considered if the student can demonstrate that the student is a successful and independent reader, is reading at or above grade level, and is ready to be promoted to the fourth grade. Tools that may be utilized to reevaluate any retained student may include subsequent assessments, alternative assessments, and portfolio reviews, in accordance with rules of the State Board of Education. Retained students may only be promoted midyear prior to November 1 and only upon demonstrating a level of proficiency required to score at the proficient level on the third-grade statewide criterion-referenced test, or upon demonstrating proficiency in reading at the third-grade level through a screening instrument administered in accordance with law, and upon showing progress sufficient to master appropriate fourth-grade-level skills, as determined by the school district. A midyear promotion shall be made only upon the agreement of the parent or guardian of the student and the school principal.

**REFERENCE: 70 O.S. §1210.508C**

SCHOOL COUNSELOR

The school counselor is a member of the teaching team. The counselor is concerned for the welfare of the child, instructional goals of the teachers, and communication between home, school, and the community.

Student referrals to the school counselor are made by the principal and teachers. Parents wishing a conference may contact the counselor from 8:00 a.m. to 9:00 a.m. each school day. Students may make arrangements to visit the counselor through their homeroom teachers.

✓ website page for counselor

Necessary??  
Yes.

## TESTING PROGRAM STUDENT SURVEYS (REGULATION)

The board of education recognizes surveys can be a valuable resource for schools and communities in determining student needs for educational services. Such collection of input from students and parents may be used to assist school staff in decision-making related to curriculum and instruction and in program development and operations. To this end, the board supports the use of appropriate surveys in accordance with the guidelines contained in these regulations.

Administrators, teachers, other staff members, and the board of education may use surveys for many purposes, which may include, but are not limited to, the need for student services, the determination of prevailing views pertaining to proposed policies and/or practices, or the determination of student knowledge and/or attitudes related to a specific subject or unit. These are examples of surveys and not intended to be an all-inclusive listing. Administrative approval is required for surveys. Responses will not be used in any identifying manner.

Surveys used in any experimental program or research project will be subject to the requirements outlined in policy found elsewhere in this manual. (See GVA-P.) Parents shall have the right to inspect all instructional material that will be used for a survey, analysis, or evaluation as part of a federal program.

Prior to administering a survey, the board of education must approve all those that are received by the superintendent that include reference to any of the factors listed below. No student may, without prior parental consent, take part in a survey, analysis, or evaluation in which the primary purpose is to reveal information concerning:

1. Political affiliations or beliefs of the student or the student's parent;
2. Mental and psychological problems of the student or the student's family;
3. Sex behavior and attitudes;
4. Illegal, antisocial, self-incriminating, and demeaning behavior;
5. Critical appraisals of other individuals with whom students have close family relationships;
6. Legally recognized privileged or analogous relationships, such as those of lawyers, physicians, and or ministers; or
7. Income (other than that required by law to determine eligibility for participation in a program or for receiving financial assistance under such program); or
8. Religious practices, affiliations, or beliefs of the student or the student's parent.

Prior consent to any such survey, analysis, or evaluation means the prior written consent of the student's parent or guardian or, if the student is emancipated, of the student.

Surveys conducted for other agencies, organizations, or individuals must have the recommendation of the superintendent of schools and the approval of the board of education as to content and purpose. The results of such approved surveys must be shared with the board of education.

**TESTING PROGRAM, STUDENT SURVEYS, REGULATION (Cont.)**

Parents/guardians shall have the right to inspect, upon their request, a survey created by a third party before the survey is administered or distributed by a school to a student. Such requests shall be made in writing with a response to be at least two weeks in advance of any survey to be given.

Overall survey results following decisions must be shared with all parties who request such information.

Parents/guardians shall be notified at least annually, at the beginning of the school year, of this policy and when enrolling students for the first time in district schools. This notification must explain that parent/guardians, or students 18 or older, have the right to "opt the student out of participation," in writing, in the following activities:

1. The collection, disclosure, and use of personal information gathered from students for the purpose of marketing or selling that information. This does not apply to the collection, disclosure, or use of personal information collected from students for the exclusive purpose of developing, evaluating, or providing educational products or services for, or to students, such as:
  - A. College or other postsecondary education recruitment, or military recruitment;
  - B. Book clubs, magazines, and programs providing access to low-cost literary products;
  - C. Curriculum and instructional materials used in schools;
  - D. Tests and assessments;
  - E. Student recognition programs; and
  - F. The sale by students of products or services to raise funds for school-related activities.
2. The administration of any survey that delves into the restricted sensitive subject areas identified and listed above; or
3. The administration of any non-emergency, invasive physical examination or screening that is required as a condition of attendance, administered by the school not necessary to protect the immediate health or safety of the student or other students and not otherwise permitted or required by state law.

Parents/guardians of a student shall also have the right to inspect, upon request, any instructional material used as part of the educational curriculum.

**Definitions**

The term "survey" includes an evaluation.

The term "invasive physical examination" means any medical examination that involves the exposure of private body parts, or any act during such examination that includes incision, insertion, or injection into the body, but does not include a hearing, vision, or scoliosis screening.

**TESTING PROGRAM, STUDENT SURVEYS, REGULATION (Cont.)**

The term "personal information" means individually identifiable information, include a student's or parent's name, address, telephone number, or social security number.

The term "instructional material" means instructional content that is provided to a student, regardless of format. It does not include tests or academic assessments.

These terms do not include ordinary classroom activities or teaching techniques.

These rights transfer from the parent to a student who is eighteen (18) years of age or an emancipated minor.

Parents who believe their rights have been violated may file a complaint with the Family Policy Compliance Office, U.S. Department of Education, 400 Maryland Avenue SW, Washington D.C. 20202-8520

*THIS POLICY REQUIRED BY THE  
Every Child Succeeds Act of 2016.*

## ANIMALS IN SCHOOL

It is the policy of the Oakdale Board of Education that students, staff, and/or patrons will not bring animals onto school premises except in connection with an organized and approved school activity, or as otherwise authorized by the appropriate building principal. Written permission must be obtained from the appropriate building principal before animals are brought to school or to any school activity. Service animals will be allowed in accordance with federal law. Members of the public, staff, and students shall not be allowed to bring emotional support animals and therapy animals which do not meet the definition of a service animal on school property. An exception may be made by the superintendent for emotional support animals and therapy animals to be brought onto school premises by the school counselor for the benefit of the student body. The district shall post a sign in a conspicuous location outside the entrance of each school building stating which animals or types of animals are prohibited in accordance with Oklahoma law. The sign posted will indicate that service animals are permitted in accordance with federal law.

Authorized animals must be adequately housed and cared for while on school grounds. Only the teacher, or students designated by the teacher, is to may handle the animals. If dogs are allowed to be on school grounds by the principal, the dogs must be leashed at all times and not permitted to run at large.

If animals are to be kept on school grounds on days when classes are not in session, arrangements must be made for their care.

If a staff member or student has been bitten by an animal and the skin has been pierced, the incident must be reported immediately to the school office by the student or the supervising adult. The principal will notify public health authorities and cause the animal to be impounded for observation. Public health authorities will determine the appropriate term of confinement of the animal and method of observation.

Service animals perform some of the functions and tasks that individuals with disabilities cannot perform themselves. Service animals are not pets. There are several kinds of service animals that assist individuals with disabilities. Examples include, but are not limited to, animals that:

1. Assist individuals who are blind or have severe sight impairments,
2. Alert individuals with hearing impairments to sounds,
3. Pull wheelchairs or carry and pick-up items for individuals with mobility impairments, and
4. Assist individuals with mobility impairments with balance.

The district shall not assume or take custody or control of, or responsibility for, any service animal or the care or feeding thereof. The owner or person having custody and control of the service animal shall be liable for any damages to persons, premises, property, or facilities caused by the service animal, including, but not limited to, clean up, stain removal, etc. If a service animal is not "house broken" the service animal will be denied access to school district property.

If, in the opinion of the Superintendent or designee any service animal is out of control in the school setting or during District transportation, the matter shall be immediately reported to local law enforcement. The parent or guardian of the student having custody and control of the service animal will be required to remove the service animal from District premises immediately.

**LEGAL AUTHORITY:** 4 O.S. § 801