

RAYMOND CENTRAL PUBLIC SCHOOLS - DISTRICT #55-0161
BOARD OF EDUCATION REGULAR MEETING, WEDNESDAY, JANUARY 10, 2024
- 6:00 PM
RAYMOND CENTRAL JR-SR HIGH SCHOOL - MUSTANG ROOM
1800 WEST AGNEW ROAD
RAYMOND, NE 68428-9783

AGENDA

1. Call to Order and Pledge of Allegiance
2. Motion to Excuse Board Member's Absence
3. Open Meeting Law
4. District Mission Statement
The Raymond Central community is committed to providing a positive, challenging learning environment which prepares each individual to be a responsible citizen in an ever-changing society.
5. Annual Organizational Meeting
 - 5.1. Elections of officers
 - 5.1.1. Elect President
 - 5.1.2. Elect Vice President
 - 5.1.3. Elect Secretary
 - 5.1.4. Elect Treasurer
 - 5.2. Review Board Policy 8272 Code of Ethics

Code of Ethics

It shall be the policy of Raymond Central Public Schools that members of the Board of Education will exercise their responsibilities in accordance with the following Code of Ethics:

1. As a member of the local Board of Education, representing all the citizens of the Raymond Central School District, each Board member will recognize:
 - a. That he or she has been entrusted with the educational development of the children and youth of the community.
 - b. That the community expects that the first and greatest concern of a school Board member will be the best interest of each and every one of the young people enrolled in the district's schools.
 - c. That the future welfare of this community, of this state, and of our nation depends in the largest measure upon the quality of education provided in Raymond Central Public School to meet the needs of every learner.
 - d. That members of the Board of Education must collectively take the initiative in helping all the people in this community to have updated, accurate information about the public schools system, and to provide the finest possible school programs, school staff, and school facilities.
 - e. That by statute the authority of the Board of Education is derived from the state which is ultimately responsible for the organization and operation of the public schools and which determines the degree of discretionary power exercised by the Board representing the people of the Raymond Central community.
 - f. That a school Board member must never neglect his or her personal obligation to the community and legal obligation to the State of Nebraska, nor surrender these responsibilities to any other person, group or organization; but that, beyond this, each school Board member has a moral and civic obligation to our country which can remain strong and free only so long as public schools in the United States are kept strong and free.
2. In view of the foregoing consideration, it must be the constant endeavor of each school Board member:
 - a. To devote time, thought and study to the duties and responsibilities of a school Board member so that he/she may render effective and creditable service.
 - i. If a board member is absent from more than two consecutive (regular) board meetings and the individual is not excused by the board, a vacancy is created in that seat.
 - b. To work with fellow school Board members in a spirit of harmony and cooperation so as to convert differences of opinion which arise during discussion and debate into a consensus for the benefit of the students enrolled in Raymond Central Public Schools.
 - c. To base personal decisions upon all available facts in each situation, to vote honest conviction in every case, unswayed by partisan bias of any kind; thereafter, to abide by and uphold the final majority decision of the Board of Education.

- d. To remember at all times that individual Board members have no local authority outside the meetings of the Board of Education, and to conduct relationships with school staff members, local citizens, and all media of communication on the basis of this fact.
- e. To resist every temptation and outside pressure to use the position as a school Board member to benefit either oneself or any other individual or agency apart from the total interest of the school system.
- f. To recognize that it is as important for the Board of Education to understand and evaluate the educational program of Raymond Central Public Schools as it is to plan for the business of the school district.
- g. To bear in mind under all circumstances that the primary function of the Board of Education is to establish and maintain the policies by which the schools are to be administered, but that the administration of the educational program and the conduct of school business shall be the primary responsibility of the Superintendent of Schools and the professional and non-professional staff members who are employed to work with the Superintendent of Schools.
- h. To welcome and encourage active cooperation by citizens, organizations, and the media of communication in Raymond Central Public Schools with respect to the establishment of policy on current school operation and proposed future developments.
- i. To strive step by step to achieve the ideal conditions for the most effective service by a Board of Education to its community, in a spirit of teamwork and unwavering commitment to the American system of public education as a primary means for preservation and perpetuation of our representative democracy.

Date of Adoption: May 18, 2009

Date of Revision: September 11, 2019

5.3. Approval of committees, positions, and designations

5.3.1. Discuss, Consider and Take Action to approve Perry Law Firm and KSB Law Firm as the primary legal counsel.

5.3.2. Discuss, Consider President's appointment to board committee and representative positions

5.3.3. Discuss, Consider and Take Necessary Action to select Jones Bank, Ceresco Bank and First Northeast Bank of Nebraska as depositories of record

5.3.4. Discuss, Consider and Take Necessary action to select the Waverly News, or other newspapers of general circulation in the event of the need to publish a notice on short notice, as District Newspapers of record.

5.3.5. Discuss, Consider and Take Necessary Action to appoint Superintendent as the Every Student Succeeds Act (ESSA) and all federal programs representative

5.4. Review the plan for Review of Board Policy

5.5. Disseminate to Board members the conflict of interest policies

Conflict of Interest/Other Than Contracts or Employment

1. Members of the Board of Education of this School District shall abstain from voting on matters on which they may have a conflict of interest. Any Board member who would be required to take any action or make any decision in the discharge of his or her duties that may cause financial benefit or detriment to him or her, a member of his or her immediate family, or a business with which he or she is associated, which is distinguishable from the effects of such action on the public generally or a broad segment of the public, shall take the following actions as soon as he or she is aware of such potential conflict or should reasonably be aware of such potential conflict, whichever is sooner:
 - a. Prepare a written statement describing the matter requiring action or decision and the nature of the potential conflict; and,
 - b. Deliver a copy of the statement to the Secretary of the Board of Education, who shall enter the statement into the public records of the School District.

The Board member shall take such action as the Commission shall advise or prescribe to remove himself or herself from influence over the action or decision in the matter.

2. The provisions of paragraph 1 above shall not prevent a Board member from making or participating in the making of a School District-related decision to the extent that the individual's participation is legally required for the action or decision to be made. In such event, the Board member shall report the occurrence to the Commission.
3. Except as defined in Nebraska statute and this policy, conflict of interest of a Board member shall not prevent a Board member from serving on the Board or restrict the hiring or purchasing practices of this School District.
4. The Superintendent, or the Superintendent's designee, shall provide:
 - a. Each Board member with copies of state statutes of Nebraska pertaining to conflicts of interest at the organizational meeting of the Board of Education held at the regular School Board meeting in January of each year. In addition, any newly appointed or elected Board member shall be provided such statutes.
 - b. When possible, provide each Board member with a list of financial matters on the agenda to come before the Board of Education at the next regular meeting in sufficient detail to allow the Board member to identify potential conflicts of interest and report and receive advice from the Commission.
5. For purposes of this policy, immediate family member shall be defined as a child residing in the Board member's household, a Board member's spouse or an individual claimed by that Board member or the Board member's spouse as a dependent for federal income tax purposes.

Legal Reference: Neb. Rev. Stat. § 49-1425; § 49-14,101; § 49-14,102; § 49-14,103;
§ 49-14,103.01; § 49-14,103.02; § 49-14,103.03; § 49-14,103.04;
§ 49-14,103.05; § 49-14,103.06; § 79-818; § 79-544 and § 49-1499.

Date of Adoption: May 18, 2009

Date of Revision: July 13, 2016

Conflict of Interest/Employment of Family Member of Board Member or Supervisor and Employment of Board Member

1. A member of the Board of Education or an administrator or other employee with supervisory responsibilities may employ or recommend or supervise the employment of an immediate family member if:
 - a. He or she does not abuse his or her official position (for this purpose, “abuse” means employing an immediate family member: who is not qualified for and able to perform the duties of the position; at an unreasonably high salary; or who is not required to perform the duties of the position);
 - b. He or she makes a full disclosure on the record to the Board of Education and a written disclosure to the Superintendent and/or Secretary of the Board; and,
 - c. The Board of Education approves the employment or supervisory position.
2. No immediate family member of a Board of Education or an administrator or other employee with supervisory responsibilities shall be employed by the School District:
 - a. Without first having made a reasonable solicitation and consideration of applications for such employment.
 - b. Who is not qualified for and able to perform the duties of the position.
 - c. For any unreasonably high salary.
 - d. Who is not required to perform the duties of the position.
3. Neither the Board of Education nor an administrator or other employee with supervisory responsibilities shall terminate the employment of another employee so as to make funds or a position available for the purpose of hiring an immediate family member.
4. This policy shall not apply to an immediate family member of a member of the Board of Education or an administrator or other employee with supervisory responsibilities who was previously employed in a position with the School District prior to the election or appointment of the Board member or employee. Prior to or as soon as reasonably possible after the official date a Board member takes office or an employee assumes his or her responsibilities, such Board member, administrator or other employee with supervisory responsibilities shall make a full disclosure of any immediate family member employed in a position subject to this policy.
5. A member of the Board of Education may not be engaged in a contract to teach with the Raymond Central Public School District. Nor shall a member of the Board of Education cast a vote in favor of the election of any employee when the Board member is related by blood or marriage to such employee.

Legal Reference: Neb. Rev. Stat. § 79-818; § 79-544; § 49-1499.04 and § 49-144.05

Date of Adoption: May 18, 2009

Conflict of Interest/Contracts

It shall be the policy of Raymond Central Public Schools that any contract whether oral or written, formal or informal, which is entered into by the school district and in which a member of the Board of Education is directly or indirectly interested, is voidable unless certain reporting, disclosure and abstention requirements are met. The school district is authorized to enter into a contract in which a member of the Board of Education is directly or indirectly interested so long as:

1. The Board member makes a declaration on the record regarding the nature of his/her interest prior to official consideration of the contract.
2. The affected Board member does not participate in consideration or discussion of the contract.
3. The Board member does not vote on the granting of the contract except that if the number of members of the Board declaring an interest in the contract would prevent the Board with all members present from securing a quorum in the issue, then all members may vote on the matter.
4. The Board member does not in any way participate in the inspection, operation, administration or performance under the contract on the part of the district.

It shall further be the policy of Raymond Central Public Schools that the above provisions apply not only to formal contracts but also to open accounts.

Legal Reference: Neb. Rev. Stat. § 49-14,103.01

Date of Adoption: May 18, 2009

6. Consent Agenda

6.1. Regular Minutes of December 13, 2023

Raymond Central Public Schools (District 0161) Board of Education Regular Meeting

Wednesday, December 13, 2023 at 6:00 PM

Raymond Central Jr-Sr High School - Mustang Room

1800 West Agnew Road

Raymond, NE 68428-9783

Present: Mary Benes, Matt Blanchard, Brad Breitreutz, Cathy Burklund, Bill Lange, Derek Matulka. Also in attendance were: Lynn Johnson, Superintendent; Mark Smith, Jr-Sr High Principal; Tony Kobza, Activities Director/Asst Principal; Steve Rose, Elementary Principal; Deb Kruse, Asst Elementary Principal; and Amanda Coufal, SpEd Coordinator.

Call to Order and Pledge of Allegiance

President Breitreutz called the meeting to order at 6:00 PM and the Pledge of Allegiance was said.

Motion to Excuse Board Member's Absence

All members were present.

Open Meeting Law

The audience was reminded that Open Meeting Laws would be followed.

District Mission Statement

The Raymond Central community is committed to providing a positive, challenging learning environment which prepares each individual to be a responsible citizen in an ever-changing society.

Consent Agenda

Motion by Matulka, second by Burklund to approve the consent agenda as presented including the regular meeting minutes of November 15, 2023; November financial statement; and monthly bills. RCV 6-0. Motion carried.

Regular Minutes of November 15, 2023

Financial Statement/Report

Monthly Bills

Correspondence/Recognition

Congratulations to Olivia Masek who is a recipient of the Global Seal of Biliteracy. The Global Seal of Biliteracy is a credential that celebrates language skills and expands future opportunities for its recipients. A uniform standard is used to empower awardees to be an asset in multilingual environments. The Global Seal enables recipients to showcase their language skills to any school or employer across state lines and national borders, with a unique serial-numbered document.

Congratulations to Katie Donahue for writing and receiving a Frontier Coop Grant in the amount of \$2,835.00 to set up the veterinary science classroom with curriculum, supplies, materials, equipment.

Public Forum

Reports

Administrative Reports

Submitted by Mark Smith, Jr-Sr High School Principal

HAPPENINGS: With the end of 1st semester approaching, the number of special events begins to slow down during the month of November. We also had our Thanksgiving break, so this last month was a short month. The main activity involved students and teachers engage in learning in our classrooms!

TEACHER/STAFF PREP: There were no professional development days for the entire staff in the last month. Our next professional development day will be on January 3.

On December 8, administrators and three teachers from the Jr/Sr High joined a small group from the elementary schools to work on our instructional model and aligning it with our teacher performance framework. This important work, led by Deb Kruse, will help both administrators and teachers better plan and evaluate effective instruction in our classrooms.

The Jr/Sr high is looking to finish 1st semester strong. Classes are planning to give end of semester assessments December 19-21.

Submitted by Tony Kobza, Asst Jr-Sr High School Principal/Athletic Director

We have added a touch screen to our wall outside the Mustang Room. This holds our Senior Pictures. They are working on the code as the touchscreen is rotating but not interacting.

We have started moving dirt on the baseball and softball practice area on the East edge of the property. The land is now flattened and smoothed. It will sit until Spring to allow it to settle before moving forward. We have marked off the ballfield areas as well as a shot and discus area which will allow us to have coaches and kids closer together during practice and events.

Finally, we are working to replace/repair the mats on the front of the stage as they are showing some dramatic wear and tear. We are waiting on a quote for repair as well as information on whether the current mats are covered through a warranty.

Submitted by Steve Rose, Elementary Principal and Deb Kruse, Assistant Elementary Principal

Last week I was able to sit in on part of a Socratic Seminar in 5th Grade at Valparaiso today! Ms. Cooper's class was engaged and excited to discuss their learning! The Socratic Seminar is an essential element of Wit & Wisdom's approach to speaking and listening. These seminars provide a space for students to engage in the joyful rigor of building knowledge as part of a community of learners and allow teachers to assess students' speaking and listening skill development. Each seminar focuses on a rigorous question that provokes new thinking and requires students to rely on evidence from module texts. Students prepare for these structured academic conversations by gathering evidence to respond to the seminar question. Students apply the crafts of speaking and listening to express and extend what they have learned from their reading and writing.

Professional Development - In preparation for Math Curriculum adoption next year, Sam Butler from the ESU has been coming to the district to do walkthroughs with Steve and Deb during math class and collect data about current classroom instruction in K-12 Mathematics. He presented it to our elementary staff members on November 29th and 30th. He discussed the rubric that he was using and how the ESU and we as a district will use this data as we begin the exploration of new curriculum in the Fall of 2024. He will return with the same process in the Spring and compile the sets of data to help us make an informed decision.

School-wide Expectations - We held our monthly Mustang Assembly and students continue to receive recognition for being "Caught in the Act".

Special Events:

- Kindergarten through 2nd Grade and 5th Grade Band held a concert at the HS on December 5. Thanks to Zac Ochsner and Melissa Graue for putting this all together. The kids sounded great!
- Mrs. Rockemann had student artwork for Kindergarten through 2nd Grade on display during the Winter Concert. It was an amazing display of our talented students' work. A huge thank you to

Mrs. Rockemann for taking the time to organize and display the students' art. The parents and other family members were blown away!

- Students and staff are participating in some fun Holiday and Kindness themed activities for the Holiday Season. Both schools either have had or will have a "Grinch" Day where we completed STEM projects as well as collected items for sharing with local families in need. Special thanks to Kim Hudson, Andrea Rockemann and Lori Morgan for their planning and preparation for this event.

Submitted by Amanda Coufal, Director of Special Education

Life Skills Thanksgiving Meal: On November 21, the high school life skills students held a successful and delicious Thanksgiving meal. This project is an amazing way for the students to plan and execute essential life skills. They brainstormed food ideas, found recipes, made a shopping list, compared prices, shopped for ingredients, followed a recipe, cooked, and prepared a celebration for their family as each student had the opportunity to invite at least two people. This is always a great celebration to showcase their hard work and spend time with their family and friends.

After the students went shopping for ingredients, they went out for lunch. This is a valuable, educational experience for our students as they had the opportunity to order for themselves and pay for their meals. This may seem like a small thing but for our students, this is something that they do not get to do all the time.

Special thanks to Stacey Doan, Jody Albrecht, Jessica Knopp, Ashley Matulka and Leann Wiese for their hard work and preparation to hold another successful Thanksgiving meal and creating memorable memories!

Vocational Rehabilitation: We currently have 16 students signed up to receive Vocational Rehabilitation services. VR works with schools across the state to help students plan for the future, identify their skills, abilities, and interests, explore careers, and learn about self-advocacy.

At the age of 14, during IEP meetings, we give parents information about VR services and encourage them to sign up. Once they are juniors and seniors, VR gets more involved. Jenny Vosburg is our VR specialist. Jenny helps students with job exploration counseling, transition assessments, instruction in self-advocacy, counseling on post-secondary training opportunities, and advice on post-secondary education and training opportunities based on the student's interests and abilities including discussions about college education requirements, financial aid and student accommodations.

VR staff works with students on preparing for the workforce by practicing job applications, creating resumes, teaching interview skills, and completing mock interviews. VR also advises families to learn about resources in the community (developmental disabilities, social security and medicaid and long-term supports in the community). This is a great, free resource for our students and families.

Student Board Member

Submitted by Rosalie Tvrdy, Student Body President

Hello and happy December! As the semester is winding down, I want to talk about some of the key highlights of the semester. When we came back to school, we were greeted by a new set of rules regarding phones and hats, and this rule was that teachers would decide whether or not it was a "green zone" or "red zone" for the phones or hats. Throughout the semester, these rules have proven very effective, and the environment for students has been a lot more enjoyable. Students are happy that they are able to wear hats to school, and many teachers are happy that they do not have to bother students about taking their hats off. Throughout the semester, we had many fun activities during homecoming week that the student council had planned, and we also had many speakers come in and talk to students about pressing issues that we face. Student council has also been starting and completing different food drives, and the items donated go right back into the community to students through the Caring Shelves here at the high school.

For the student council's winter food drive, we are collecting toys and winter wear items, and those things will be donated right back into the school to the Caring Shelves. Each student council member was required to bring two things. For each person that brings something to donate, they will get their name entered into a drawing for a gift card of their choice.

Another thing that I wanted to highlight was the sports and activities around the school. One Act this year did very well, considering the conflicts that they had, and one person, Ellie White, had to pick up three different parts during the show when someone got sick. Quiz Bowl has also qualified for the national quiz bowl competition in Chicago, Illinois. The wrestling and basketball teams have also been working hard and winning games and matches. Last week the pep band also played at the basketball games and played really well. There were also many people that came to the high school for the elementary Christmas concert, and families were able to see the artwork of their students. FBLA has also been working on getting more kids to attend the State Leadership Conference in April. We have been decorating Christmas cards, and we are going to donate them to a nursing home so that the residents can send Christmas cards to their families. Throughout the semester, there have been many good things that have been happening and things that have been accomplished. I want to say Happy Holidays, and let's have an even better semester when we come back next year!

Superintendent's Report

State Education Conference - I attended on November 16-17 with three other board members. Princess Sarah Culberson was the keynote speaker on Thursday and she shared her story of how she reunited with her birth father and became the current Princess of Sierra Leone in doing so. As an adopted child in a bi-racial family, she focuses on the importance of building a culture of acceptance and belonging. Our second keynote speaker was Richard Hight who is an internationally known artist and who was able to create two phenomenal drawings minutes before and during his presentation. He introduced us to his daughter and shared how her challenges in life have helped him to find the real beauty in others and in life in general and how that has inspired his creative talents. Governor Jim Pillen was our final keynote speaker. He talked about his vision and priorities for K-12 education and he reminded us that he is an education friendly governor. He did express his concerns that so many school districts raised the tax levy after the state dollars that he arranged to feed into the state aid formula.

Teacher Shortage: I attended a session on teacher shortage. My takeaway was that the state is continuing to seek creative ways to incentivize teaching as a profession (offering grants, shortened pathways, etc.). Individual school districts are creating pay structures, housing provisions and other incentives.

Personnel Matters: I attended a session with legal counsel who shared examples of how to effectively work with and/or separate from teachers who are not a good fit for the district. The focus was on how to use the evaluation process and hearings effectively.

Dueling Piano's, School Law Style: This session focused on a variety of personnel and student issues relative to First Amendment Rights and a variety of other relevant school hot topics including the use of social media. Importance of having clear policies and evaluation practices and following them.

Pain in the App: This presentation shared the most relevant and recent cases about students use of social media and technology. It is important to know when the intersection of the two is an actual impediment to education and that is when schools can take action. Nearly 1/2 of teens report that they have been a victim of bullying on social media (namely name calling) and You Tube is used by highest percentage of teens. The surgeon general warns of the dangers of social media on developing minds. Social media use at a young age is predictive of a subsequent decrease in life satisfaction for certain developmental stages? Specifically a concern for girls 11-13 and boys 14-15? Youth who spend more than 3 hours a day on social media face two times the risk of experiencing poor mental health outcomes (including depression and anxiety)? "Social media may also perpetuate body dissatisfaction, disordered eating behaviors, social comparison, and low self-esteem, especially among adolescent girls."

QCPUF Fund - Peggy and I would like to get the \$10,000 that has been left in this fund

expended. We consulted with NDE to obtain a list of ideas of permissible expenditures for this \$10,000 to drop the account balance to zero. Any project that includes accessibility modifications would qualify. We will likely expend it on the playground surfacing which is an accessibility item. The NDE told us that the other approach would be for the board to take action to transfer the funds to the general fund and eliminate the account.

NASB and NRCSA Monthly Update

Update on Superintendent Goals

Goal I. Student Performance: Continue the development and initial implementation of the district Instructional Model Framework. (G1.PI3) (G6.PF1)

Goal II. Student Performance: Continue the implementation of the Multi-Tiered Systems of Supports (MTSS-B) model in K-12 is implemented with fidelity to support student learning and social-emotional/behavior instructional support. (G1.PI3) (G7.PF1.PF2)

Goal III. Facility/Student Performance: Continue the development of a 10 year facility master priority list that addresses maintenance and improvements for existing buildings and grounds and to determine configuration of students to maximize use of facilities and instruction. (G4.PF1)

Goal IV. Continue the development of safety and security practices for Raymond Central Public Schools. (G8.PF1.PF2.PF3.PF4)

Review Months: September, December, March, July

Goal I. Student Performance: Continue the development and initial implementation of the district Instructional Model Framework. (G1.PI3) (G6.PF1)

- The model is in draft form. The administrative team plans to finalize by end of Semester 1 and present the model to staff in Semester 2. The current PD work on engagement practices and Classroom Culture are represented within the model.
- The model has been identified and the administration and team of teachers met for a full day to correlate the instructional model with the existing Teacher Performance and Evaluation Framework. The implementation of model will begin second semester.

Goal II. Student Performance: Continue the implementation of the Multi-Tiered Systems of Supports (MTSS-B) model in K-12 is implemented with fidelity to support student learning and social-emotional/behavior instructional support. (G1.PI3) (G7.PF1.PF2)

- Components of Tier 1 being implemented include: school wide expectations taught and practiced, high quality SEL curriculum being implemented at all levels with high levels of fidelity, all teachers trained, common handbook language for behaviors,
- Components of Tier II being implemented: four small groups working with LMPH at Jr High, individual work with LMPH at all levels,
- The Student Problem Solving Teams are meeting on a consistent basis and formulating strategies to assist students who are not meeting expectations. We are working on the fidelity of the process at the Jr/Sr high level.
- SEL curriculum is being taught at all levels.
- We are using LMPH to do grade level and group instruction at 6-8 level.

Goal III. Facility/Student Performance: Continue the development of a 10 year facility master priority list that addresses maintenance and improvements for existing buildings and grounds and to determine configuration of students to maximize use of facilities and instruction. (G4.PF1)

- Facility Committee has updated the list and presented it to the board of education.
- Schedule of priorities for 2023-24 have been identified
- Distributed and survey to staff and presented the board with information on next steps with school configuration.
- Worked with Facilities Committee to identify the key projects and summer projects for 2023-24.
- Decided to keep configuration of PK the same after reviewing with teachers and key Early Childhood committee members.

Goal IV. Continue the development of safety and security practices for Raymond Central Public Schools. (G8.PF1.PF2.PF3.PF4)

- Continued review and revision of the EOP with input from Nebraska Public Policy Center
- Reunification table talk being developed for January 3
- Reunification kits are in hand.
- Door access control and additional camera for the two elementary campuses.
- Obtaining quotes for the handicap solid surface for playgrounds.

Safety Report

Facilities Report

- The electric bus and the 2023 Bluebird bus should be in before Christmas break.
- Tony is obtaining quotes for safety straps to the two main baskets in the competition gym. At the same time he is going to get quotes on replacing those structures in totality as they are the old style.
- We are obtaining quotes to replace the stage mats in the competition gym. These are threadbare and look bad in such a high traffic area for the community.
- I will be adding new stage curtains to our Master Priority List. This is something to address in the future. Curtains get really mistreated when the stage is part of the competition gym and it is hard to protect the curtains.
- I learned that we are eligible to apply for the next round of Clean Bus grants to obtain an electric bus. BUT, we are not a 'priority' school because our free and reduced numbers are not high enough and the rebates are not as high so the out of pocket cost on an electric bus would be around \$160,000. This is slightly more than the cost of a new diesel. This is the reason that the Facility Committee suggests that we seek bids for a new diesel as opposed to an electric and it gives us time to see if we like the new electric bus.
- Football Field Sound System - I think that we need to get the sound system repaired. Do we move forward with the \$55,000 + item OR do we work with the Foundation to see if they want to fundraise for a new digital scoreboard and sound system for \$272,000.
- I updated the Master Priority Summer Project List to include the softball/baseball field that was not included.

Important Upcoming Dates:

Board Committee Reports

Curriculum & American Civics Committee (Burklund-chair, Lange, Matulka)

Facilities & Transportation Committee (Blanchard-chair, Burklund, Matulka)

Finance Committee (Blanchard-chair, Breitreutz, Burklund)

Negotiations Committee (Blanchard-chair, Benes, Lange)

Policy Committee (Breitkreutz-chair, Benes, Lange)

New Business

Discuss, Consider and Take Necessary Action to approve the Annual Audit

Motion by Lange, second by Matulka to approve the Annual Audit. RCV 6-0. Motion carried.

Discuss, Consider and Take Necessary Action to Approve Multiple Policies as Amended in Series 5000-Students

Motion by Burklund, second by Lange to approve the amended 5000 policies as presented: 5001A-Forms for Health Related Admission Requirements; 5002A-Affidavit and Parent Release; 5003-Assignment of Students: Grade Placement and Transfer of Students; 5006-Option Enrollment; 5007A-Application for Foreign Exchange Student; 5008-Student Attendance; 5010-School Census; 5012-Military Recruiters; 5103-Extracurricular Activity; 5204-Grading System; 5205-Graduation; 5206-Early Completion Plan; 5305-School Dances; 5306-Drug and Alcohol Testing; 5402-Child Abuse and Neglect; 5403-Married Students; 5406-Search and Seizures; 5408-Health Inspections; 5411-Law Violations; 5415-Anti-Bullying Policy; 5417-School Wellness Policy; 5418-Homeless Students; 5419-Use of Restraints and Seclusion; 5421-Student Privacy Protection Policy; 5501-Bus Transportation; 5505-Safe Pupil Transportation Plan; 5601-Asthma and Allergic Reaction Protocol with Waiver of Emergency Response to Life Threatening Asthma. Superintendent Johnson shared that many of the changes in these policies were to make policy and practice consistent. The one policy that has substantial change policy 5103 Student Discipline in Activities. RCV 6-0. Motion carried.

Discuss and Consider the Review of Board Policies with no changes in Series 5000-Students be noted with Review Date of December 13, 2023

The following 5000 policies were reviewed with no changes: 5000-Introductory Statement; 5001-Admission Requirements; 5002-Discontinuance of Enrollment for Children Younger Than Six Years of Age; 5004-Full-time and Part-time Enrollment; 5004A-Application of Non-Public School Student for Part-time Enrollment; 5005-Student Residence, Admission and Contracting for Educational Services; 5006A-Resolution and Appendix "1" Form; 5007-Foreign Exchange Students; 5008A-Attendance Improvement Plan; 5009-Attendance During The School Day (Dismissals and Field Trips); 5011-Parent-Student Handbook; 5101-Student Discipline; 5102-Alternative Education Programs or Plans For Expelled Students; 5104-Drug and Substance Use and Prevention; 5201-Promotion and Retention; 5202-Student Records; 5202A-Notification of Rights Under FERPA; 5203-Academic Progress; 5205A-Graduation Requirements Standard Diploma; 5207-Make-Up Work; 5208-High School Credit for Middle School Courses; 5301-Association Activities; 5302-Student Organizations; 5303-Student Activities; Hazing, Fund-Raising and Supervision; 5304-Selection of Students for Participation in Activities; 5401-Anti-discrimination, Anti-harassment, and Anti-retaliation; 5401A-Complaint Form; 5405-Corporal Punishment; 5407-Vandalism; 5409-Communicable Diseases; 5412-Missing Persons; 5413-Requests to Contact Students and Student Interviews by Non-School Personnel; 5414-Identification of Learners with High Ability; 5416-Student Fees Policy; 5416A-Student Fees; 5418A-Homeless Student Policy - Forms; 5420-Dating Violence; 5422-Pregnant and Parenting Students; 5503-Use of School Buses; 5504-Special Education Transportation; 5506-RCPS Safe Pupil Transportation Plan; 5602-Naloxone in School.

Discuss, Consider and Take Necessary Action to approve the PK Handbook and set fee charges for preschool for the 2024-25 school year

The board discussed that we have not increased tuition since the preschool was started. Increasing to \$100 would still have our tuition on the low side. There was some discussion about whether this would negatively impact enrollment. The board shared that this is an expensive program for the district and the

increased tuition helps to offset this burden and also sends the message that it is valued service. Motion by Benes, second by Matulka to approve the Preschool Handbook as presented and set the tuition fee of \$100.00 per month for the 2024-2025 school year. RCV 6-0. Motion carried.

Old Business

Discuss, Consider and Take Necessary Action to approve selection of superintendent interview candidates

Search firm consultants Fred Helmink and Rob Hanger highlighted the strengths of each of the Superintendent candidates with the Board of Education.

<Potential> Closed Session to evaluate superintendent candidates, credentials, and background information

Motion by Matulka, second by Blanchard to enter closed session at 7:07 PM to discuss any weaknesses of the candidates presented, noting that it is clearly necessary for the protection of the public interest and for the prevention of needless injury to the reputation of an individual. RCV 6-0. Motion carried.

The Board returned to regular session at 8:15 PM.

Motion by Matulka, second by Lange to approve Scott Axt, Jason Brown, Bryon Hanson and Andrew Offner as Superintendent candidates to be interviewed on Saturday, December 16, 2023. RCV 6-0. Motion carried.

Next Regular Board Meeting

The next regular Board of Education Meeting will be held Wednesday, January 10, 2024.

Adjournment

Motion by Breitkreutz, second by Matulka to adjourn the meeting at 8:20 PM. RCV 6-0. Motion carried.

6.2. Financial Statement/Report



**Raymond Central Public Schools
General Fund Comparison to Previous Year
December 2023**

	12/1/2023 - 12/31/2023	12/1/2022 - 12/31/2022
Balance - Beginning of Month	\$2,814,422.05	\$2,351,397.13
Receipts	\$398,910.73	\$267,313.22
Interest Earned	\$4,720.64	\$2,426.93
Disbursements Outstanding Cks	<u>-\$1,286,244.39</u>	<u>-\$887,480.65</u>
Balance - End of Month	\$1,931,809.03	\$1,733,656.63



Raymond Central Public Schools General Fund Receipts Dec. 2023

LANCASTER COUNTY TREASURER		
	TAXES	\$16,557.20
	PERSONAL PROP TAXES	\$1,370.74
	MOTOR VEHICLE TAXES	\$26,054.15
	FINES & FEES	\$942.60
SAUNDERS COUNTY TREASURER		
	TAXES	\$15,885.85
	MOTOR VEHICLE TAXES	\$21,950.00
	AG LAND TAX CREDIT	\$4,944.38
SEWARD COUNTY TREASURER		
	TAXES	\$1,843.11
	MOTOR VEHICLE TAXES	\$450.16
	FINES & FEES	\$128.41
BUTLER COUNTY TREASURER		
	FINES & FEES	\$5.00
STATE OF NEBRASKA		
	STATE AID	\$120,810.00
	SPED	\$160,413.00
	MEDICAID	\$1,718.06
PRE K TUITION		
	PRE K TUITION	\$2,790.00
ESU RECEIPTS		
	ESU RECEIPTS	\$532.58
RCPS HOT LUNCH FUND		
	DEC PAYROLL EXPENSES	\$22,287.64
JONES BANK		
	GENERAL FUND INTEREST -DEC	\$4,720.64
NON-REVENUE RECEIPTS		
	FARMERS COOP STOCK EQUITY PAYT	\$179.15
	MISC REFUND, EMPLOYEE JURY PAYT	\$48.70
TOTAL		\$403,631.37

DECEMBER 2023	Percent of Year Completed		33.00%			
2023-2024 RECEIPTS		M-T-D	Y-T-D	Y-T-D	Y-T-D	Y-T-D
	2023-2024	RECEIVED	RECEIVED	RECEIVED	% Received	% Received
ACCOUNT	ANTICIPATED	2023-2024	2023-2024	2022-2023	2023-2024	2022-2023
Property Taxes	\$8,116,238.00	\$34,286.16	\$1,391,103.30	\$1,282,227.04	17.14%	15.76%
Motor Vehicle Tax	\$499,000.00	\$48,454.31	\$197,502.33	\$188,228.45	39.58%	41.83%
Public Power Tax (5% Gross)	\$39,000.00	\$0.00	\$0.00	3,826.29	0.00%	10.93%
Carline Taxes	\$2,530.00	\$0.00	\$539.88	\$474.26	21.34%	15.81%
Other Tuition	\$0.00	\$0.00	\$0.00	\$0.00	0.00%	0.00%
Interest	\$8,000.00	\$4,720.64	25,551.60	8,667.76	319.40%	270.87%
Local License Fees	\$3,900.00	\$0.00	\$0.00	\$0.00	0.00%	0.00%
Other Local Receipts(Pre-K)	\$12,000.00	\$2,790.00	8,832.62	4,281.25	73.61%	35.68%
Fines & License Fees	\$26,000.00	\$1,076.01	\$11,891.85	\$12,354.17	45.74%	41.18%
ESU Receipts	\$7,300.00	\$532.58	2,644.78	\$3,312.96	36.23%	47.33%
State Aid	\$1,213,974.00	\$120,810.00	494,741.00	385,392.00	40.75%	40.00%
Special Education	\$972,397.00	\$160,413.00	160,413.00	74,082.00	16.50%	15.12%
Special Educ. Transportation	\$21,000.00	\$0.00	\$0.00	\$0.00	0.00%	0.00%
Homestead Exemption	\$0.00	\$0.00	\$0.00	4,801.25	0.00%	0.00%
High Ability Learners	\$5,500.00	\$0.00	\$0.00	\$5,909.00	0.00%	98.48%
Pro-Rate Motor Vehicles	\$19,000.00	\$0.00	\$2,520.87	\$2,474.40	13.27%	13.75%
State Apportionment	\$103,000.00	\$0.00	\$0.00	\$0.00	0.00%	0.00%
Relief to Property Tax Payers	\$0.00	\$0.00	\$0.00	\$0.00	0.00%	0.00%
Other State Receipts	\$23,000.00	\$0.00	\$0.00	\$0.00	0.00%	0.00%
Personal Property Tax Credit	\$0.00	\$1,370.74	8,664.33	10,311.78	100.00%	100.00%
Title I /II Funds	\$49,000.00	\$0.00	\$0.00	\$0.00	0.00%	0.00%
Other Federal Receipts	\$0.00	\$0.00	\$0.00	\$0.00	0.00%	0.00%
SPED IDEA Grant PreK	\$124,000.00	\$0.00	\$0.00	\$0.00	0.00%	0.00%
Private Grants-College Access	\$3,500.00	\$0.00	\$3,150.00	\$3,101.61	90.00%	100.00%
Carl Perkins	\$25.00	\$0.00	\$0.00	\$0.00	0.00%	0.00%
Other Non-Revenue Receipts	\$1,000.00	\$227.85	\$9,582.85	3,128.16	958.29%	100.00%
Ag Land Property Credit	\$0.00	\$4,944.38	\$4,944.38	\$0.00	100.00%	100.00%
ESSER (COVID-19) Funds	\$0.00	\$0.00	\$0.00	\$0.00	100.00%	0.00%
Sale of Property	\$3,000.00	\$0.00	\$0.00	\$0.00	0.00%	0.00%
MIPS-Medicaid-Public Schools	\$8,900.00	\$1,718.06	\$15,052.72	\$8,043.71	169.13%	85.57%
TransferOther Fund/ Imprest	\$0.00	\$0.00	\$0.00	\$60.00	0.00%	0.00%
Insurance Adjustments	\$1,000.00	\$0.00	\$0.00	\$9,231.50	0.00%	100.00%
TOTAL	\$11,262,264.00	\$381,343.73	\$2,337,135.51	\$2,009,907.59	20.75%	19.27%
2023-2024 DISBUREMENTS		M-T-D	Y-T-D	Y-T-D	Y-T-D	Y-T-D
	2023-2024	DISBURSED	DISBURSED	DISBURSED	% Disbursed	% Disbursed
CATEGORY	BUDGET	2023-2024	2023-2024	2022-2023	2023-2024	2022-2023
Instructional Services	\$5,285,000.00	\$383,211.23	\$1,579,976.99	1,496,954.17	29.90%	28.75%
Special Education	\$2,017,427.00	\$195,803.04	\$719,256.27	\$559,255.71	35.65%	28.01%
Guidance	\$227,900.00	\$29,046.01	115,342.67	77,844.97	50.61%	34.16%
School Health Nurse	\$112,750.00	\$9,377.68	36,836.74	37,156.15	32.67%	32.95%
Safety & Security	\$52,151.00	\$0.00	29,926.42	\$21,622.82	57.38%	41.46%
Activities	\$95,020.00	\$3,553.15	\$61,147.78	\$36,962.36	64.35%	38.90%
Media, Technology	\$710,125.00	\$42,344.36	\$180,811.91	\$197,652.87	25.46%	27.83%
General Admin (Supt/BOE/Legal)	\$428,800.00	\$26,072.39	\$109,655.94	\$105,026.21	25.57%	24.49%
School Administration (Principals)	\$762,100.00	\$57,295.21	\$234,162.82	\$226,345.79	30.73%	29.70%
Business	\$322,600.00	\$11,555.53	\$51,736.93	57,660.72	16.04%	17.87%
Operation of Plant	\$789,500.00	\$46,984.40	\$206,511.89	\$200,585.72	26.16%	25.41%
Maintenance of Plant	\$517,500.00	\$47,256.05	\$124,337.35	\$84,346.13	24.03%	16.30%
Pupil Transportation	\$536,549.00	\$400,072.75	\$457,154.78	\$101,271.71	85.20%	18.87%
Fed. Grants (PreK expenses)	\$129,975.00	\$6,194.97	\$33,343.37	\$42,602.41	25.65%	32.78%
Transfers	\$0.00	\$0.00	\$0.00	\$0.00	0.00%	0.00%
TOTAL	\$11,987,397.00	\$1,258,766.77	\$3,940,201.86	\$3,245,287.74	32.87%	27.13%



**Raymond Central Public Schools
Financial Report 12/31/2023**

GENERAL FUND

Purpose: Pays day to day expenses for District

Funded by: Local Taxes, State/Fed Reimb. for SPED, State Aid, Title 1, other misc. grants

For RC: Salaries, benefits, educ expenses, technology, building and grounds maintenance, transportation

Cash Balance - Dec. 1, 2023	\$2,814,422.05
Dec. Receipts	\$403,631.37
Dec. Disbursements	<u>-\$1,286,244.39</u>
Cash Balance -Dec. 31, 2023	\$1,931,809.03

LUNCH FUND

Purpose: Pays all expenses for Hot Lunch program including kitchen payroll.

Funded by: Parent/Student/Staff payments for meals and State/Fed Reimb. for meals served.

For RC: Salaries, benefits for HL staff, food, milk, supplies, equipment, repairs associated with HL program.

Note: General Fund can transfer funds into HL account if needed. No transfers out of HL Fund.

Cash Balance - Dec. 1, 2023	\$133,845.35
Dec. Receipts	\$33,582.56
Dec. Disbursements	<u>-\$50,587.91</u>
Cash Balance -Dec. 31, 2023	\$116,840.00

BUILDING/SINKING FUND

Purpose: To acquire new sites, improve existing buildings, all new building/construction expenses.

Funded by: Local Taxes, sale of property.

For RC: Previously used for HVAC projects, new propane tank HS, pays property taxes on farmland south of HS.

Would also be used for construction.

Cash Balance - Dec. 1, 2023	\$1,719,104.19
Dec. Receipts	\$6,427.18
Dec. Disbursements	<u>-\$19,712.50</u>
Cash Balance -Dec. 31, 2023	\$1,705,818.87
Certificate of Deposit	\$1,029,869.53
Interest Paid - CD	<u>\$10,116.42</u>
Combined Balance - Dec 31, 2023	\$2,735,688.40

HIGH SCHOOL BOND FUND

Purpose: Pay principal/interest on loans for new construction and additions.

Funded by: Local Taxes through a bond.

For RC: Used to pay interest/principal payts on 2009 HS Bond

Cash Balance - Dec. 1, 2023	\$1,007,437.47
Dec. Receipts	\$5,966.68
Dec. Disbursements	<u>-\$631,421.25</u>
Cash Balance -Dec. 31, 2023	\$381,982.90

DEPRECIATION FUND

Purpose: Pays to 'replace' not add. Fixing a roof, replacing a bus, upgrading systems.

Funded by: General Fund (GF) transfers at YE only with specific purpose identified.

For RC: In 8/2023, \$400,000.00 was transferred from the GF budget that was planned but not spent. This transfer was earmarked for truck/bus purchase, technology, safety upgrades and curric. materials.

Cash Balance - Dec. 1, 2023	\$839,095.58
Dec. Receipts	\$1,222.27
Dec. Disbursements (Includes CD Transfer)	<u>-\$551,542.50</u>
Cash Balance -Dec. 31, 2023	\$288,775.35
Certificate of Deposit #1&2	\$1,248,433.90
New CD#3	<u>\$400,000.00</u>
Combined Balance - Dec 31, 2023	\$1,937,209.25

QUALIFIED CAPITAL PURPOSE UNDERTAKING FUND

Purpose: Pays for removal of environmental hazards (mold, asbestos) and reduction/removal of accesiblity barriers in school buildings.

Funded by: Local taxes via tax levy.

For RC: Not used at this time.

Cash Balance - Dec. 1, 2023	\$10,595.64
Dec. Receipts	\$7.58
Dec. Disbursements	<u>\$0.00</u>
Cash Balance -Dec. 31, 2023	\$10,603.22

EMPLOYEE BENEFIT FUND - UNEMPLOYMENT

Purpose: Part of the General Fund. Can be used to pay unemployment, benefits, early retirement

Funded by: General Fund transfers at YE only with specific purpose identified.

For RC: In 8/2023 \$100,000.00 was transferred from the GF earmarked to pay Admin Benefit costs during the 23-24SY.

Cash Balance - Dec. 1, 2023	\$236,731.24
Dec. Receipts	\$72.02
Dec. Disbursements (Transfer to CDs)	<u>-\$235,500.00</u>
Cash Balance -Dec. 31, 2023	\$1,303.26
Certificate of Deposit	\$16,466.97
Interest Paid CD	\$166.02
New CD#2	\$200,000.00
New CD#3	<u>\$35,500.00</u>
Combined Balance - Dec 31, 2023	\$253,436.25



Raymond Central Public Schools
Student Activities Fund Balances Dec. 2023

<u>Activity Name</u>	<u>Beginning Balance</u>	<u>Revenues</u>	<u>Expenses</u>	<u>Balance</u>
After School Club	2,387.13	0.00	0.00	2,387.13
Annual	8,092.00	1,520.00	0.00	9,612.00
AP Funds	45,239.69	6,137.60	0.00	51,377.29
APEX	369.05	0.00	0.00	369.05
ART CLUB	137.68	147.00	0.00	284.68
Athletics	229,329.14	7,416.47	9,581.01	227,164.60
Band	(76.80)	183.96	30.00	77.16
Band Trip	10,669.76	0.00	0.00	10,669.76
Baseball	518.09	0.00	0.00	518.09
Boys BB	360.45	50.00	1,439.50	(1,029.05)
Ceresco Book Fair	91.22	0.00	0.00	91.22
Ceresco Field Trips	0.00	0.00	0.00	0.00
Ceresco Fundraising	2,233.57	0.00	0.00	2,233.57
Ceresco Pop	69.74	0.00	0.00	69.74
Cheerleaders	4,184.72	0.00	1,752.30	2,432.42
Choir	14,359.76	0.00	0.00	14,359.76
Class 2024	195.26	0.00	0.00	195.26
Class 2025	210.16	78.92	1,504.34	(1,215.26)
Class 2028	4,248.35	0.00	0.00	4,248.35
Class 2029 Field Trip Funds C	2,806.38	0.00	0.00	2,806.38
Class 2030 Field Trip Funds C	3,056.11	0.00	0.00	3,056.11
Class 2031 Field Trip Funds C	3,243.68	0.00	0.00	3,243.68
Class 2031 Field Trip Funds V	2,472.34	0.00	0.00	2,472.34
Class 2032 Field Trip Funds C	2,040.89	0.00	0.00	2,040.89
Class 2032 Field Trip Funds V	1,959.64	0.00	0.00	1,959.64
Class 2033 Field Trip Funds C	891.33	0.00	0.00	891.33
Class 2033 Field Trip Funds 2033	798.90	0.00	0.00	798.90
Class 2035 Cer	83.38	0.00	0.00	83.38
Class 2035 Val	592.96	0.00	0.00	592.96
Class of 2026	205.18	0.00	0.00	205.18
Class of 2027	3,588.00	25.18	0.00	3,613.18
Class of 2034 Ceresco	650.73	0.00	0.00	650.73
Class of 2034 V	387.59	0.00	0.00	387.59
College Access Grant	2,638.57	0.00	50.00	2,588.57
Computer	0.00	0.00	0.00	0.00
Cross Country	2,004.56	0.00	0.00	2,004.56
Culinary Snack Cart	1,390.69	0.00	0.00	1,390.69
Dance Team	(1,135.50)	406.95	269.97	(998.52)
DI	4,614.68	0.00	0.00	4,614.68
Drama Act	729.01	15.00	0.00	744.01
Elem Fines	555.04	0.00	0.00	555.04
Elem Fundraising	1,500.23	0.00	304.96	1,195.27
Elem PE	2,167.50	0.00	0.00	2,167.50
Elem Pictures/Yearbook	3,026.72	0.00	0.00	3,026.72

<u>Activity Name</u>	<u>Beginning Balance</u>	<u>Revenues</u>	<u>Expenses</u>	<u>Balance</u>
Elem Prof Development	4,797.94	0.00	0.00	4,797.94
Elem Student Council	483.85	0.00	0.00	483.85
FBLA Act	2,884.54	522.05	2,171.62	1,234.97
FFA Act	38,089.51	396.25	15,275.22	23,210.54
Fines	2,394.58	0.00	0.00	2,394.58
Football	2,788.40	0.00	0.00	2,788.40
Girls BB	(73.56)	150.00	150.00	(73.56)
Girls Wrestling	956.82	0.00	0.00	956.82
Golf Activity	1,068.91	0.00	0.00	1,068.91
HAL	59.66	0.00	0.00	59.66
Hot Lunch	347.63	0.00	0.00	347.63
HS Caring Shelves	4,527.94	500.00	433.88	4,594.06
HS Pop	1,926.01	70.00	0.00	1,996.01
HS Quiz Bowl	(555.10)	335.99	0.00	(219.11)
JH Boys BB	15.31	113.40	0.00	128.71
JH Football	382.84	0.00	0.00	382.84
JH Girls BB	372.93	436.77	0.00	809.70
JH Speech	1,516.45	0.00	0.00	1,516.45
JH Student Council	1,255.12	0.00	0.00	1,255.12
JH Track	604.57	0.00	0.00	604.57
JH Volleyball	1,339.13	0.00	0.00	1,339.13
JR Achievements	629.57	0.00	0.00	629.57
Kindness Acct	19,250.73	0.00	0.00	19,250.73
Library	1,856.23	10.00	0.00	1,866.23
Life Skills	2.41	0.00	0.00	2.41
Mock Trial	380.96	0.00	0.00	380.96
National Honor Society	649.27	0.00	0.00	649.27
Pre-Kindergarten	4,585.36	0.00	0.00	4,585.36
Professional Development	21,469.13	0.00	141.66	21,327.47
PTO	0.00	0.00	0.00	0.00
Rain Garden	459.50	0.00	0.00	459.50
RC Backpack	30,336.23	0.00	633.65	29,702.58
RC Blue Crew	(207.27)	0.00	0.00	(207.27)
RC Concessions	14,651.59	8,143.46	7,063.45	15,731.60
RC Foundation	1,910.12	0.00	1,886.12	24.00
Restitution	190.00	0.00	0.00	190.00
Score Vision	4,901.64	0.00	0.00	4,901.64
Service Fees (Activity Acct)	6,556.45	1,846.47	31.70	8,371.22
Skills USA	208.80	0.00	0.00	208.80
Social Justice	194.12	0.00	0.00	194.12
Softball	6,391.63	0.00	0.00	6,391.63
Spanish Club	2,572.29	750.83	300.08	3,023.04
Speech	12,245.73	30.00	2,519.50	9,756.23
Spring Musical	2,187.89	0.00	0.00	2,187.89
Staff Inservice	854.92	0.00	0.00	854.92
'Stang Gang Student Section	(0.01)	0.00	0.00	(0.01)
Student Council	7,310.16	0.00	0.00	7,310.16
Student Pop	772.80	0.00	0.00	772.80

<u>Activity Name</u>	<u>Beginning Balance</u>	<u>Revenues</u>	<u>Expenses</u>	<u>Balance</u>
Testing	4,365.23	0.00	0.00	4,365.23
Track	1,201.20	0.00	0.00	1,201.20
TShirt Press Acct	0.00	150.00	0.00	150.00
Val Book Fair	10,094.77	0.00	0.00	10,094.77
Val Field Trips	0.00	0.00	0.00	0.00
Val Fundraising	8,781.79	0.00	0.00	8,781.79
Val Pop	1,115.05	0.00	0.00	1,115.05
VolleyBall	10,662.16	0.00	0.00	10,662.16
Weight Room	4,000.00	0.00	0.00	4,000.00
Wrestling	(170.23)	3,600.00	0.00	3,429.77



Raymond Central Public Schools
Student Fees Fund Balances Dec. 2023

<u>Activity Name</u>	<u>Beginning Balance</u>	<u>Receipts</u>	<u>Expenses</u>	<u>Balance</u>
Activity Pass	8,836.00	0.00	0.00	8,836.00
Ag-Ed Labs	2,137.39	0.00	0.00	2,137.39
Art Class	3,019.43	25.00	198.07	2,846.36
Chromebooks	6,268.37	130.00	0.00	6,398.37
Computer Science	327.97	0.00	77.98	249.99
Drama	0.00	28.28	0.00	28.28
FBLA	0.00	0.00	0.00	0.00
FFA	100.00	0.00	0.00	100.00
Foods Class	3,350.86	25.00	751.51	2,624.35
Mock Trial	(1,744.34)	1,744.34	0.00	0.00
Service Fees (Student Fees)	1,412.21	699.39	25.82	2,085.78
Skills USA	1,510.00	0.00	0.00	1,510.00
Speech	175.00	0.00	0.00	175.00
Sports Fees	17,805.22	160.00	0.00	17,965.22
Tech Ed	2,179.07	0.00	636.79	1,542.28

6.3. Monthly Bills



Raymond Central Public Schools

Bills Paid December 2023

General Fund - Report of Bills Paid December 2023

	<u>Check Date</u>	<u>Vendor Name</u>	<u>Description</u>	<u>Amount</u>
1	12/20/2023	RCPS Dist. #161	December Payroll	715,054.51
2	12/13/2023	Truck Center Companies	2024 Thomas Electric Bus	375,000.00
3	12/13/2023	Educational Service Unit #2	SPED 2nd Quarter 23-24	24,581.25
4	12/13/2023	Educational Service Unit #2	Indepen. School 2nd quarter 23-24	18,199.93
5	12/11/2023	Sentry Electric Inc.	Exterior Lights& New Amp Panel HS	13,300.00
6	12/13/2023	Family Services	Therapy Services HS Fall 2023	10,899.00
7	12/13/2023	Norris Public Power	Electricity HS	8,968.14
8	12/18/2023	NE-DAS State Acctg	Erate Cost Recovery	6,532.30
9	12/13/2023	Mechanical Sales Parts Inc.	Exhaust Fan Replace HS	6,326.70
10	12/13/2023	Pine Cove Consulting	Managed Tech Service Nov/Dec 2023	6,150.00
11	12/13/2023	Liberty Lawn & Landscape	Lawn Treatment/Re-Seeded HS	5,090.00
12	12/13/2023	Pine Cove Consulting	2 75inch Touchscreens HS	5,050.00
13	12/13/2023	Crane Sales/Service	Replace Pump & Motor - Outriggers	4,452.70
14	12/18/2023	Alternative Service & Repair	Bus 22 Replace Rear Brakes	3,140.25
15	12/11/2023	Hands of Heartland	SPED Transitional Program Nov	3,079.75
16	12/11/2023	Follett School Solutions Inc. Software	Library Software Destiny C,V,HS	2,815.51
17	12/11/2023	Summit Fire Protection	Fire Extinguisher Annual Inspect. HS	2,425.00
18	12/11/2023	Omaha Public Power Dist	Electricity C	2,397.75
19	12/11/2023	Access Systems, Inc	Copiers Nov 2023	2,357.52
20	12/13/2023	Electronic Contracting Company	Repair/Reset Master clock HS	2,319.19
21	12/13/2023	Butler Public Power District	Electricity V	2,217.53
22	12/11/2023	Computer Hardware	MacBook Pro- HS Principal Office	1,949.95
23	12/11/2023	Computer Hardware	Projector-JrHS Science Room	1,798.00
24	12/18/2023	Alternative Service & Repair	Bus 19B Oil/Filter, Replace Temp Sensor	1,786.22
25	12/13/2023	Grunwald Mechanical Contractors	HS Boiler Repair	1,575.00
26	12/11/2023	Bauer Built Tire & Service	Replace Tires Bus 17B	1,456.28
27	12/18/2023	Shaw, Hull & Navarrette	Auditors Fee 22-23 Audit Final Pymt	1,295.26
28	12/11/2023	Perry Guthery Haase & Gessford	Legal Services	1,264.00
29	12/13/2023	Kiner Supply Company	Building Repair Supplies -Plumbing V	1,161.24
30	12/13/2023	BrightArrow Technologies Inc.	1yr subscription-District Notifications	1,097.55
31	12/18/2023	Alternative Service & Repair	Bus 17A Replace Rear brakes shoes/drums	1,040.50
32	12/13/2023	Windstream	Phone HS, Fax	1,040.32
33	12/13/2023	Brooke L. Cheleen	Novt 2023 SPED Physical Therapy	995.91
34	12/13/2023	Johnson Hardware Co.	Replace Bath Door-Student Vandalism HS	942.96
35	12/18/2023	Alternative Service & Repair	Bus 17B Oil/Filters	886.27
36	12/11/2023	Bauer Built Tire & Service	Replace Tire Bus 19A	854.39
37	12/18/2023	Alternative Service & Repair	Bus 21 Oil/Filter Change, Fix Horn	836.57
38	12/11/2023	Aqua Systems	Water Filters HS	828.00
39	12/13/2023	MCS	Custodial Supplies, all Locations	808.13
40	12/11/2023	Otte Oil & Propane Inc.	Propane C	761.84
41	12/14/2023	US Bank	Maint Supplies HS	757.15
42	12/18/2023	Alternative Service & Repair	DOT Inspt:11,13,17A,B,18,19A,B,C, 21,22	750.00
43	12/18/2023	Alternative Service & Repair	Bus 19A Oil/Filters	674.02
44	12/13/2023	Waste Connections Co	Garbage HS, V	652.27
45	12/01/2023	Jared Shanahan	Cell Phone Annual Reimbursement	600.00
46	12/13/2023	TK Elevator Corporation	Elevator Mainten. HS, V 1st Quart. 2024	569.28
47	12/11/2023	Ron's Rolloffs Inc.	Dumpster/Dump Fees HS	544.35
48	12/14/2023	US Bank	SPED Supplies	525.43
49	12/14/2023	US Bank	Supplies: Concessions, Prof Dev, Veteran	454.34
50	12/13/2023	College Board	PSAT tests	398.70

	<u>Check Date</u>	<u>Vendor Name</u>	<u>Description</u>	<u>Amount</u>
51	12/13/2023	NE Fire Marshal Agency	Annual Fee	360.00
52	12/13/2023	Village Of Ceresco	Utilities C	331.04
53	12/11/2023	Priefert, Tom	Parent Mileage Reimb Nov 2023	291.80
54	12/13/2023	Johnstone Supply	Filter Order HS	286.08
55	12/19/2023	Maly, Linda	Title1 Services-St Johns-Weston Oct-Dec	270.00
56	12/11/2023	Donald R. Prentice	Extermination Service Fall Outside	259.00
57	12/11/2023	Holiday Inn Kearney	Hotel Counselor Mtg V,C	249.90
58	12/18/2023	NE Public Health Environmental Lab	Water Testing HS	247.00
59	12/14/2023	US Bank	PreK3 Classroom Supplies	244.39
60	12/20/2023	Steve Rose	Reimbursement Mileage Nov/Dec 2023	237.11
61	12/11/2023	Mattice Lock Shop	Rekey PreK hallway door	235.00
62	12/20/2023	NDEE-Public Water Operators	Water Operator License JS Annual Fee	230.00
63	12/11/2023	Intermedia.net, INC	Phone Service	219.48
64	12/13/2023	Village Of Valparaiso	Utilities V	205.67
65	12/13/2023	Nebraska Safety Center	Transportation Class - CS	200.00
66	12/13/2023	NECentral Equipment, Inc	Bus Parts	199.05
67	12/11/2023	Ward`s Science	Dissection Specimen Ag Ed Class Supplies	193.98
68	12/13/2023	Jackson Services Inc.	Mats/Mops	192.02
69	12/13/2023	NE Council of School Administrators	State Principals Conference	190.00
70	12/14/2023	US Bank	Supplies JrHSBB, One Act	189.18
71	12/11/2023	KSB School Law PC LLO	Legal Service	187.50
72	12/07/2023	Amanda Ehlers	Reimb Mileage Nov	184.06
73	12/11/2023	Millard South HS	Raymond Central Speech Fees: Squashfest	184.00
74	12/13/2023	O` Reilly Auto Parts	Oil for Buses	177.24
75	12/11/2023	Brad Breitreutz	Mileage/Parking Reimb NASB Conf	171.96
76	12/13/2023	Wahoo-Wav.-Ashl. News	Publications	169.05
77	12/13/2023	Jaymar Business Forms	HotLunch Fund Checkstock-Reorder	168.67
78	12/18/2023	Whitehead Oil Co	DEF/Fuel	165.55
79	12/11/2023	Pitney Bowes (Lease)	Postage Machine HS Lease	159.57
80	12/13/2023	William V. MacGill & Co	Health Office Supplies	157.55
81	12/07/2023	Crees, Jennifer	Mileage Reimb Health Tech Nov 2023	157.20
82	12/14/2023	US Bank	Ignitor Water Heater C	154.16
83	12/13/2023	Menards Lincoln	Maint Supplies HS Bldg	151.37
84	12/13/2023	Hotsy Equipment Co.	Bus Maint Supplies Power Washer	144.60
85	12/20/2023	Graue, Melissa	Mileage Reimb Nov/Dec 2023	143.45
86	12/18/2023	LSE High School	Lincoln Southeast Speech entry	136.00
87	12/18/2023	Quest Diagnostics	3rd Party Drug Testing	129.00
88	12/14/2023	US Bank	SLP Supplies	126.59
89	12/11/2023	Norris High School	Speech Meet Entry 12/2	126.00
90	12/07/2023	Trenhaile, Clair	Reimb Mileage Nov 2023	123.40
91	12/13/2023	Home Depot Pro	Custodial Supplies HS	120.84
92	12/07/2023	Coufal, Amanda	Mileage Reimb Nov	114.63
93	12/13/2023	Lincoln High School	Speech Entry Fee 12/8	112.00
94	12/13/2023	Midwest Petroleum Equipment	Annual Testing/Inspection Tank HS	109.50
95	12/11/2023	Matheson Tri-Gas Inc.	Welding Tank Rental	102.16
96	12/18/2023	League-NE Municipalites	CTE for JS	100.00
97	12/19/2023	Weeping Water HS	BBall Holiday Tourney Fee	100.00
98	12/18/2023	Electronic Contracting Company	Quarterly Monitoring Fee- Alarms HS	87.00
99	12/11/2023	Dietze Music	Instrument Repair	83.10
100	12/11/2023	Peggy Breitreutz	Mileage/Parking Reimb NASB Conf	82.05
101	12/11/2023	Electronic Contracting Company	Quarterly Monitoring Fee- Alarms C	81.00
102	12/11/2023	Great Minds	3rd Grade Student Books	79.00
103	12/11/2023	Burkland, Cathy	Mileage/Parking Reimb NASB Conf	74.19
104	12/14/2023	US Bank	F&CS Class/Student Supplies	71.91
105	12/11/2023	One Source	Employee Background Checks	71.00
106	12/11/2023	Oak Valley Lumber Co	Building Maint Supplies	70.55

	<u>Check Date</u>	<u>Vendor Name</u>	<u>Description</u>	<u>Amount</u>
107	12/11/2023	Cadotte, Grace	Judge for 11/17 Millard South	60.00
108	12/11/2023	Dexter, Dex	Judge for 11/17 Millard South	60.00
109	12/11/2023	Enevoldsen, Eleanah	Judge for 11/17 Millard South	60.00
110	12/18/2023	Enevoldsen, Eleanah	Lincoln Southeast Spch judge 12/15	60.00
111	12/11/2023	Hain, Zach	speech judge - norris	60.00
112	12/11/2023	Hicks, Meg	speech judge - norris	60.00
113	12/18/2023	Hicks, Meg	Lincoln Southeast Spch judge 12/15	60.00
114	12/11/2023	McFarling, Andrea	Judge for 11/17 Millard South	60.00
115	12/13/2023	McFarling, Andrea	Speech Judge 12/8	60.00
116	12/18/2023	McFarling, Andrea	Lincoln Southeast Spch judge 12/15	60.00
117	12/11/2023	RC Annual	Supt Office-Yearbook	60.00
118	12/14/2023	US Bank	GimKit Subscription Comp Business Class	59.88
119	12/11/2023	Grafton and Associates	State/National Dues FFA	54.00
120	12/07/2023	ASI	Payflex Admin Fees	50.00
121	12/14/2023	US Bank	Elem PE Supplies	42.81
122	12/14/2023	US Bank	Time Clock Ribbons	39.56
123	12/14/2023	US Bank	Class SuppliesTech Ed	34.78
124	12/21/2023	Becky Studebaker	Reimb. Electricity-Bus Month 1/4	30.00
125	12/21/2023	Leann Wiese	Reimb. Electricity-Bus Month 1/4	30.00
126	12/21/2023	Matt Smith	Reimb. Electricity-Bus Month 1/4	30.00
127	12/21/2023	Suchy, Maggie	Reimb Electicity/Bus Month 1/4	30.00
128	12/14/2023	US Bank	Materials Jr English Class	27.89
129	12/13/2023	CHI Health Company Care	DOT Query Fee	25.00
130	12/13/2023	Milford HS	District One Act Fees	17.18
131	12/14/2023	US Bank	Registration SPED Honda Van	17.00
132	12/13/2023	NE Public Health Environmental Lab	Water Testing HS	15.00
133	12/11/2023	WSC Honor Festival	Wayne State Honor Band	10.00

Depreciation Fund - Report of Bills Paid December 2023

	<u>Check Date</u>	<u>Vendor Name</u>	<u>Description</u>	<u>Amount</u>
1	12/20/2023	Ceresco Bank	New CD#3 8 Month. 5.2%	400,000.00
2	12/13/2023	Master's Transportation. Inc	Used 2023 Bluebird 71 pass. Bus	99,900.00
3	12/07/2023	Kidwell	50% Down-Keyless Entry C,V	51,642.50

Employee Benefit Fund - Report of Bills Paid December 2023

1	12/12/2023	First Northeast Bank of Nebraska	CD# 2 15 Month, 5.1%	200,000.00
2	12/12/2023	First Northeast Bank of Nebraska	CD#3 91 Day, 4.5% No penalty for using	35,500.00

Hot Lunch Fund - Report of Bills Paid December 2023

	<u>Check Date</u>	<u>Vendor Name</u>	<u>Description</u>	<u>Amount</u>
1	12/20/23	RCPS Dist 161	Hot Lunch Staff Dec Payroll	22,287.64
2	12/11/2023	Cash-Wa Distributing	Food	11,289.99
3	12/11/2023	Sysco Lincoln	Food and supply	8,505.28
4	12/11/2023	Hiland Dairy	Milk	3,345.69
5	12/11/2023	US Foods Inc.	Food	2,596.73
6	12/13/2023	TechMasters Heating & Air	Repair Kitchen Freezer C	820.00
7	12/08/2023	RevTrak	Dec Revtrak Fees	600.69
8	12/13/2023	MCS	Kitchen Supplies C, HS	455.48
9	12/11/2023	Loffredo Fresh Foods	Fresh Fruit	322.12
10	12/14/2023	US Bank	Hot Lunch Foods/supplies	151.59
11	12/13/2023	Jackson Services Inc.	Kitchen Cleaning Linens	128.00
12	12/14/2023	US Bank	Kitchen Supplies HS	47.99
13	12/08/2023	Monnier, Nic	Hot Lunch Acct Refund- Alyssa	36.70

Building/Sinking Fund - Report of Bills Paid September 2023

	<u>Check Date</u>	<u>Vendor Name</u>	<u>Description</u>	<u>Amount</u>
1	12/19/2023	Wolfe Construction	Hail Repairs Gutters-BusBarn, Siding C	11,850.00



Raymond Central Public Schools Student Activities Fund Checks Dec. 2023

<u>Activity Name</u>	<u>Date</u>	<u>Vendor</u>	<u>Description</u>	<u>Amount</u>
FFA	12/13/2023	4Seasons Fund Raising	Fruit FFA Fundraiser	9,339.90
Athletics	12/18/2023	Nebraska Orthopaedic Center	1st 1/2 2024 athletic trainer	3,255.00
Speech	12/07/2023	Wyhe's Choice Fundraising	Fundraising	2,519.50
FFA	12/04/2023	Jisa Farmstead Cheese, LLC	Cheese Products FFA Fundraiser	2,509.84
FFA	12/04/2023	Ely Farms, LLC	Asparagus, Beans, and Gift Boxes	1,999.00
FBLA	12/14/2023	US Bank	FBLA Mtg Food,Ornaments,BB Tourn. Food, Valentines' Fundraiser Supplies	1,876.45
RC Education Foundation	12/14/2023	US Bank	Ag Ed Wishlist	1,820.32
Service Fees (Activity Acct)	12/07/2023	RCPS Student Fees	poinsettia fundraiser reimb	1,504.34
RC Concessions	12/18/2023	Pepsi Cola Of Lincoln	pop/water for concessions	1,492.60
Boys Basketball	12/04/2023	MJSApparel	Fall clinic shirts	1,078.00
FFA	12/04/2023	National FFA Organization	FFA Jackets and Scarves	1,010.00
Cheer	12/13/2023	Varsity Spirit Fashion Attn: AR	Extra Varsity Gear for Cheer	934.30
Athletics	11/16/2023	Harco Athletic Reconditioning Inc	Football Helmet reconditioning	800.00
Athletics	12/04/2023	RCPS Student Fees	Athletics Reimb Student Fees	690.00
RC Concessions	12/18/2023	RCWC	Conc. Profit from 12/8 conc.	661.85
RC Backpacks	12/18/2023	B&R Stores Inc	Vouchers	633.65
RC Concessions	12/04/2023	Super C	Pizza restock for concessions	540.00
Athletics	12/07/2023	Awards Unlimited Inc	record board update	538.50
RC Concessions	12/18/2023	RC Athletics	Conc. Profit from 12/8 conc.	441.23
FFA	12/18/2023	Jisa Farmstead Cheese, LLC	Cheese FFA Fundraiser	416.48
Cheer	12/14/2023	US Bank	Choreography charge for cheer	400.00
RC Concessions	12/14/2023	US Bank	nacho cheese for the concession	395.67
RC Concessions	12/18/2023	RCPS Girls JH BB	Conc. Profit from 12/7 conc.	387.30
HS Caring Shelves	12/14/2023	US Bank	Thanksgiving boxes	383.96
RC Concessions	12/18/2023	RC Spanish Club	Conc. Profit From 12/1 conc.	371.99
Cheer	12/18/2023	Nebraska Coaches Association	State Cheer registration	330.00
RC Concessions	12/18/2023	Pepsi Cola Of Lincoln	pop/water for concessions	321.45
Athletics	12/04/2023	Lakeview Community Schools	Wr. Invite \$175 boys \$160 girls	315.00
Elem Fundraising	12/14/2023	US Bank	Mustang Way T Shirts-Students	304.96
Spanish Club	12/14/2023	US Bank	Tshirts	300.08
Athletics	12/07/2023	Hunt, Rusty(Donald)	12/8 dual tourney official	300.00
Athletics	12/07/2023	Hunt, Nathan	12/8 dual tourney official	300.00
Athletics	12/07/2023	Woolsey, Brian	12/8 dual tourney official	300.00
Athletics	12/07/2023	Sisel, Evan	12/8 dual tourney official	300.00
RC Concessions	12/18/2023	Raymond Central Quiz Bowl Team	Conc. profit from 12/9 conc.	297.30
RC Concessions	12/18/2023	RC Athletics	Conc. Profit from 12/7 conc.	258.20
RC Concessions	12/18/2023	RC Athletics	Conc. Profit From 12/1 conc.	247.99
Athletics	12/07/2023	RCPS Student Fees	officials checks from 11/28 reimb	240.00
Boys Basketball	12/13/2023	Hauff Mid America Sports	Gear	207.74
Dance Team	12/04/2023	Heartland Championships	competition fee	200.00
RC Concessions	12/18/2023	RC Athletics	Conc. profit from 12/9 conc.	198.20
RC Concessions	12/11/2023	RCPS FBLA	Conc. Profit from 11/18	196.35
RC Concessions	12/04/2023	Sysco Lincoln	concessions supplies	187.79
FBLA	12/14/2023	US Bank	Food for Meeting	180.47
RC Concessions	12/13/2023	Super C	ten hamb. pizzas for conc. 12/8	180.00
Athletics	11/16/2023	Scheel, Ken	Assignor's Fee for JH/JV bball	150.00
Athletics	12/07/2023	Gore, Coleman	Track Wrestling 12/8 dual tourney	150.00
Athletics	12/07/2023	Krivohlavek, Seth	Varsity BB Official 12/9	150.00
Athletics	12/07/2023	Krivohlavek, Bo	Varsity BB Official 12/9	150.00
Athletics	12/07/2023	Lanham, Troy	Varsity BB Official 12/7	150.00
Athletics	12/07/2023	Gillespie, Robert	Varsity BB Official 12/7	150.00
Athletics	12/07/2023	Meyer, Devan	Varsity BB Official 12/7	150.00
Athletics	12/08/2023	Terry, Graver	Varsity BB Official 12/9	150.00
Athletics	12/13/2023	Fort Calhoun Public School	Girls Wrestling Invite Fee 12/12	150.00

<u>Activity Name</u>	<u>Date</u>	<u>Vendor</u>	<u>Description</u>	<u>Amount</u>
Athletics	12/13/2023	Platteview HS	Entry Fee for Boys Wr. 12/15	150.00
Girls Basketball	12/19/2023	Tvrdy, Brandon	Video Production Payment	150.00
Professional Development	12/14/2023	US Bank	Staff supplies	141.66
Athletics	12/04/2023	Nebraska Coaches Association	NCA Sportsmanship Summit	140.00
RC Concessions	12/11/2023	RCPS Band	Conc. Profit from 11/28 conc.	138.98
RC Concessions	12/18/2023	Cash-Wa Distributing	candy and nacho chips	125.39
RC Concessions	12/11/2023	Class of 2027	Conc. profit 11/16 jhbbb	113.40
FBLA	12/14/2023	US Bank	Food for JH BB Tournament	101.26
Athletics	12/07/2023	Palmyra Schools	JH BBB Tourney Entry Fee 12/9	100.00
Boys Basketball	12/11/2023	RC Post Prom	Tix	100.00
RC Concessions	12/07/2023	Del Gould Meat Co., Inc	hot dogs for concessions	96.00
RC Concessions	12/11/2023	RC Athletics	Profit from 11/28 conc.	92.65
RC Concessions	12/13/2023	Super C	Five hamb. pizzas for conc. 12/9	90.00
Cheer	12/18/2023	Cheer Sounds	game day music	88.00
Athletics	12/11/2023	Class of 2025	Conc.Profit	78.92
RC Concessions	12/11/2023	RC Athletics	Conc. profit 11/16 jhbbb	75.60
Athletics	11/16/2023	Hunt, Rusty(Donald)	Assignor's Fee for wrestling	75.00
Athletics	12/13/2023	Platteview HS	Girls Wrestling Invite Entry	75.00
RC Concessions	12/14/2023	US Bank	RC Concessions Pizza Trays	66.11
RC Education Foundation	11/16/2023	RC Education Foundation	Returned item - Spanish Wishlist	65.80
RC Concessions	12/18/2023	Sysco Lincoln	Popcorn Oil	60.54
Athletics	12/07/2023	Scheel, Ken	12/7 jvbb official	60.00
Athletics	12/07/2023	Holtz, Heath	12/7 jvbb official	60.00
Athletics	12/07/2023	Smith, Ken	12/7 jvbb official	60.00
Athletics	12/07/2023	Tobin, Reinwald	12/7 jvbb official	60.00
Athletics	12/07/2023	Wall, Jerry	12/9 JVBB Official	60.00
Athletics	12/07/2023	Steiger, Larry	12/9 JVBB Official	60.00
Athletics	12/07/2023	Wallman, Jordan	JV BB Official 12/9	60.00
Athletics	12/07/2023	Tobin, Reinwald	12/9 JVBB Official	60.00
Boys Basketball	12/14/2023	US Bank	Boys BB	53.76
College Access Grant	12/14/2023	US Bank	thanks you for mock interviewers	50.00
HS Caring Shelves	12/14/2023	US Bank	Breakfast items	49.92
Athletics	12/14/2023	US Bank	Chain, Sign, and Carabiners	49.34
Dance Team	12/14/2023	US Bank	Earrings for competition team	44.97
Athletics	12/13/2023	Awards Unlimited Inc	baseball record board update	44.25
Service Fees (Activity Acct)	12/08/2023	RevTrak	Service Fees (Activity Acct)	31.70
Band	12/18/2023	Kearny High School	Underclassman Honor Band	30.00
RC Concessions	12/18/2023	Sysco Lincoln	Popcorn	28.80
Dance Team	12/07/2023	Matulka, Rose	refund for ldd dance camp	25.00
FBLA	12/14/2023	US Bank	Christmas Ornament FBLA Mtg	13.44



Raymond Central Public Schools
Student Fees Fund Checks Dec. 2023

<u>Activity Name</u>	<u>Date</u>	<u>Vendor</u>	<u>Description</u>	<u>Amount</u>
F&CS Student Fees/Supplies	12/14/2023	US Bank	Foods/Culinary Class Groceries-Nov	578.67
Tech Educ Student Fees	12/18/2023	Menards Lincoln	Tech Ed Class Stud. Fee	572.43
Art Class Student Fees	12/14/2023	US Bank	HS Art Supplies/Students	198.07
F&CS Student Fees/Supplies	12/13/2023	MCS	Aprons for Students	172.84
Chromebook Student Fees	12/14/2023	US Bank	Computer ScienceClass Stud. Fee	77.98
Tech Educ Student Fees	12/14/2023	US Bank	Tech Ed Class Stud. Fee	64.36
Service Fees (Student Fees)	12/08/2023	RevTrak	Service Fees (Student Fees)	25.82

7. Correspondence/Recognition



Raymond Central
Public School, Superintendent
1800 West Agnew Road
Raymond, NE 68428

December 22th, 2023

Attention: Superintendent and Board of Education

Re: Raymond Central Teammates

Dear Sir – Madam:

January 1, 2024 marks the start of National Mentoring Month. In recognition of National Mentoring Month, I want to offer the Board of Education, the School Administration and the Staff of the Raymond Central Schools a sincere “**THANK YOU**” on behalf of the Raymond Central TeamMates Board, Mentors and Mentees.

Throughout the first half of 2023-24 school year, with the support of the School's administration and staff, the Raymond Central TeamMates mentors and their mentees have been able to carry on their mentoring relationships in the Raymond Central Schools. This support has been an critical part of TeamMates being able to continue to provide mentoring opportunities to the youth of the community.

Again, I want to thank everyone involved for supporting the Raymond Central Teammates program.

If you have any questions about Teammates, please feel free to contact me.

Sincerely

A handwritten signature in black ink, appearing to read "Ron Bottorff", is written over a large, light-colored circular mark.

Ron Bottorff
President - RC Teammates Board
402-443-7232

“ MENTORING – IT’S FOR EVERYONE ”

Mission - Continue Fostering a Culture of Quality Mentoring in the Raymond Central Community.

8. Public Forum

9. Reports

9.1. Student Board Member Report

Hello, and Happy New Year! I hope you all had a wonderful Christmas, and that you all are excited for the second semester! Because I am involved in a lot of activities at school, I am very happy to share some new updates from these extracurricular activities. FBLA has been able to purchase a T-shirt press, in which we have made an activity where the chapter members get to make their own chapter T-shirts for this year! Yesterday, we also had a goodwill donation soup supper where we were able to work concessions, have people make T-shirts on the press and buy them from us, give back to the community, while fundraising for our chapter. In Mrs. Schaffer's classes, students have been able to design shirts, including shirts for sports, trap, the truck row, and generic Mustang apparel. Many students were very excited about this, and we are hoping to have the T-shirt press at more concessions that FBLA gets to work. We plan to have more members and students create shirt designs and have more for next year's fall activities. FBLA also has many members that are going to be attending the State Leadership Conference. We are preparing study nights so that students can come in and work on their presentations and study for the tests and events that they are going to do at the competition. Another activity that I would like to highlight is Student Council. The Student Council started a toy and winter wear donation drive last semester at the beginning of December, and the members were required to bring two items. We had many donations, all which went back into the community through the caring shelves here at the high school.

When we came back to school, we had an assembly to review the Mustang Way, and the Mustang ABC's. Those include Academics, Behavior, and Community. The administration also told us about our attendance records and how they are very good, and we have made goals to make them better. We also had a 95% passing and 5% failing for all of the grades throughout high school. This is something that administration was extremely proud of, and they made a goal

to increase the passing grades even more this semester. They told us that just showing up and putting in the work would help everyone throughout the school, and that they were very proud of the things that we have accomplished already. Again, Happy New Year, and here's to a great second semester!

9.2. Superintendent's Report

9.2.1. Report on Personal Finance

9.2.2. NASB Monthly Update

NASB BOARD QUICKS

A MONTHLY E-UPDATE OF KEY DATES FROM THE NEBRASKA ASSOCIATION OF SCHOOL BOARDS



1,960,000 Nebraskans 324,000 Students 1,700 Locally Elected School Board Members 260 Member Districts/ESUs ONE NEBRASKA

To register for an NASB event, click on the 'My Membership' link, then navigate to the 'Events' dropdown and select 'Register'. If you do not have an email and password to log in or have forgotten it, please contact NASB at 800-422-4572 for assistance. All Dates & Locations Tentative & Subject to Change

Events & Networking - <https://members.nasbonline.org/events>



Your Monthly Board Agenda Update Video Links from NASB

<https://members.nasbonline.org/news-resources/video-library>



The 2024 Legislative Session will begin Wednesday, January 3

School Board Member Week in Nebraska - January 21-28

Legislative Issues Conference - January 21-22 - Lincoln

Board Presidents Retreat - January 28-29 - Norfolk

REG NOW!



Board Presidents Retreat - February 4-5 - Kearney



Finance Workshops - Lincoln, North Platte & Gering

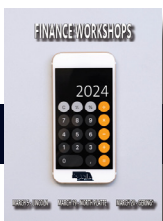

Continued on Page 2



Leadership

Innovation

Vision

Engagement

#liveNASB

#weLIVEhere

The Nebraska Association of School Boards provides programs, services and advocacy to strengthen public education for all Nebraskans. Learn more at www.NASBonline.org

NASB BOARD QUICKS

A MONTHLY E-UPDATE OF KEY DATES FROM THE NEBRASKA ASSOCIATION OF SCHOOL BOARDS



1,960,000 Nebraskans 324,000 Students 1,700 Locally Elected School Board Members 260 Member Districts/ESUs ONE NEBRASKA

PAGE 2



Amplified Finance / Budget & Finance Workshops - March 5 - Lincoln

Amplified Finance / Budget & Finance Workshops - March 19 - North Platte

Amplified Finance Workshop - March 20 - Gering

NAEP State Convention - March 27-28 - Kearney

YOUR 2024 PLATINUM AFFILIATES

If your business would like to become an Affiliate Member of NASB, please visit: <https://members.nasbonline.org/about-us/affiliate-members>



Leadership

Innovation

Vision

Engagement

#liveNASB

#weLIVEhere

The Nebraska Association of School Boards provides programs, services and advocacy to strengthen public education for all Nebraskans. Learn more at www.NASBonline.org

9.2.3. Safety Report

9.2.4. Facilities Report

9.2.5. Important Upcoming Dates:

9.3. Board Committee Reports

9.3.1. Curriculum & American Civics Committee (Burklund-chair, Lange, Matulka)

9.3.2. Facilities & Transportation Committee (Blanchard-chair, Burklund, Matulka)

9.3.3. Finance Committee (Blanchard-chair, Breitreutz, Burklund)

9.3.4. Negotiations Committee (Blanchard-chair, Benes, Lange)

9.3.5. Policy Committee (Breitreutz-chair, Benes, Lange)

10. Old Business

11. New Business

11.1. Discuss, Consider and Take Necessary Action to surplus a shaper and a jet bandsaw

11.2. Discuss, Consider and Take Necessary Action to approve a quote from KCAV to update sound system and speakers at football field



create engaging spaces

Raymond Central PS - HS Football Field Audio - 10-4-23

Proposal No. 39035

10-31-2023

Prepared for:

Raymond Central Public Schools
1800 W Agnew Rd
Raymond, NE 68428 USA

Contact:

Lynn Johnson
Superintendent
lynn.johnson@rcentral.org
(402) 785 2615

Prepared By:

KCAV - Omaha
11819 Stonegate Drive, Ste 100,
Omaha, NE 68164
(800) 798-5228

Sales Rep:

Jason Foster
AV Sales Consultant - NE
jfoster@kav.com
(800) 798-5228 x162

At KCAV, we help our clients succeed by providing audio-visual solutions that deliver results. We look forward to partnering with you to create engaging spaces to learn, work and share!

COMPANY HISTORY

Kansas City Audio-Visual (KCAV) was founded in 1953 by Mickey Adler, who offered his clients innovative solutions of the time - dictating machines, opaque projectors, and overhead projectors. Today, KCAV remains family-owned and run by Jerry & Lisa Bernard, Mickey's son-in-law and daughter. And while technology has definitely changed since 1953, KCAV's commitment to the customer has not.

At KCAV, we are committed to:

- Integrity at the core of everything we do.
- Innovative, reliable solutions that help our customers succeed.
- Long-term relationships based on trust, proactive communication, and high-quality service.

In 2018, KCAV acquired Engaging Technologies, a family-owned audio-visual technology company based in Omaha, further expanding KCAV's footprint into Nebraska and Iowa. Now, over sixty-five years later, KCAV is one of the largest suppliers of audio-visual technologies in the Midwest.

THE KCAV TEAM

We believe that people choose to do business with people. Our business model is based on offering our clients personal service from AV professionals at every stage of your experience. The KCAV Sales Team is distributed throughout Kansas, Nebraska and Missouri, allowing us to offer local, personalized service. Our Sales Team will partner with you, investing the time and resources to understand your needs, goals and realities. With that understanding, the KCAV Team will design, install, and support solutions that will transform your learning, working and sharing spaces - including meeting and collaboration spaces, classrooms and training rooms, and larger venues such as auditoriums, gymnasiums, and more.

Our full-time, industry-certified Design and Engineering Team takes pride in providing cost-effective systems that provide quality, worry-free operation. Big or small, each project receives individual attention from experienced professionals. In addition, our strong relationships with hundreds of manufacturers allow us to offer the latest technology at a cost you will appreciate.

Our KCAV Operations Team includes full-time engineers, project managers, and technical staff that hold industry-recognized certifications and strive to provide you with an exceptional client experience. In addition to providing thorough, quality, on-site installation, we place great value on providing you with proactive communication so that there are no surprises throughout the process.

After installation is complete, you'll receive on-site training in the operation of your installed systems. In addition, we offer optional high-quality professional development delivered by our Implementation Specialist, a trained educator experienced in helping users of all levels better utilize your technology investment.

Finally, the KCAV Service Team will provide you with "peace-of-mind" support, offering both telephone-based support with after-hours paging service, as well as on-site service to maximize the utilization of your new audio-visual system.

We look forward to welcoming you to the KCAV family of clients.

I. SUMMARY: This solution will provide the Raymond Central School District (hereafter “The Client”) with installation of an audio system for their Raymond Central High School Stadium.

This quote assumes that all of the equipment from previous quote (KCAV #37191) regarding the new amplifiers for the stadium is present and accounted for. KCAV will not be held responsible for missing equipment and a service fee will be applied if delay is caused.

It is recommended that the client install one 0.5 inch grommet hole at the location that they prefer the wired announcing microphone. Cabling for Bluetooth, line in, and touch panel will also be available via this hole.

II. SYSTEM DESCRIPTION:

A. High School Stadium bleachers and press box

- **Functionality Description:** The user of the system will be able to recall preset scenes from the touchpanel. One microphone can be used in the booth with two additional wireless microphones, and Bluetooth and line level inputs on the booth desk.
- **Audio Sources:**
 - One hand held microphone transmitters with desktop stands
 - OFE Anchor Audio UHF-EXT500
 - New wired microphones in booth with press-to-talk box
 - Bluetooth receiver and line level input box
- **Speakers:**
 - 8-inch, two-way speaker cabinets (five, including one from quote #37191).
 - R.5 speakers will be removed and replaced
 - Existing speaker wire will be used
- **Amplifiers:**
 - Existing Amplifiers from quote #37191.
- **Digital Signal Processor:**
 - DSP with mixing, speaker tuning, delays, EQ, feedback suppression
 - Touchpanel on desk for control

PLEASE NOTE: KCAV has included a \$4,000 contingency budget in this proposal. This budget is included to expedite acquisition and implementation of unforeseen items or requirements. Any part of this budget not used in the completion of this project will be reduced from the final invoice of the project.

The client is responsible for providing a dumpster for rubbish during the installation.

III. EXCLUSIONS: The following work is not included in our Scope of Work:

- All conduit, high voltage, wiring panels, breakers, relays, boxes, receptacles, etc.

- Concrete saw cutting and/or core drilling.
- Fire wall, ceiling, roof and floor penetration.
- Necessary gypsum board replacement and/or repair.
- Necessary ceiling tile or T-bar modifications, replacements and/or repair.
- All millwork (moldings, trim, cut outs, etc.).
- Patching and Painting.
- Permits (unless specifically provided for and identified within the contract).

DRAFT
- FOR BUDGETARY PURPOSES ONLY -
PLEASE WAIT FOR A FINAL QUOTE TO ISSUE A PO.

MATERIALS & SERVICES

MANUFACTURER	PART NUMBER	DESCRIPTION	QTY	UNIT PRICE	TOTAL PRICE
Various	OFE	Owner Furnished from P3463 Amplifiers for Main Speakers	2.00	\$0.00	\$0.00
Atlas	DS7E	Adjustable Height Desktop Mic Stand 8-13" Ebony Finish	2.00	\$44.99	\$89.98
Atlas	SMS20BIR	Stackable Heavy Dut Mic Stand with Isolation Ring	2.00	\$146.66	\$293.32
Audix	AP410M5A	Wireless, R41, Handheld, w/OM5 CAPSULE	1.00	\$568.40	\$568.40
One Systems	PM3.M-WHT	White marine-grade stainless steel pan/tilt pole mount bracket	4.00	\$366.67	\$1,466.68
One Systems	108.HTH-WHT	White 8" two-way direct weather speaker system	4.00	\$800.00	\$3,200.00
Various	OFE	Owner Furnished from P3463 Amplifier for Mid Field	1.00	\$0.00	\$0.00
Various	OFE	Owner Furnished from P3463 Mid Field Speaker	1.00	\$0.00	\$0.00
RDL	D-BT1A	Wall-Mounted Bluetooth Audio Format-A Interface	1.00	\$393.55	\$393.55
RDL	D-TPSL1A	Active Single-Pair Sender - Twisted Pair Format-A - Mini-Jack & Stereo RCA In	1.00	\$229.68	\$229.68
Shure	SM86	Cardioid Condenser Handheld Vocal Microphone	1.00	\$188.64	\$188.64
Rolls	MS211	Push to Talk Base w/ Integrated Mic Stand	1.00	\$168.00	\$168.00
Shure		Dynamic Cardioid Vocal Microphone	1.00	\$124.00	\$124.00
QSC	TSC-70-G3	Q-SYS 7" PoE Touch Screen Controller for In-Wall Mounting. Color - Black only	1.00	\$1,524.00	\$1,524.00
RDL	TX-TPR2A	Active Two-Pair Receiver - Twisted Pair Format-A	1.00	\$109.69	\$109.69
QSC	CORE 8 FLEX	Unified Core with 8 local audio I/O channels, 64x64 network 8x8 Dante	1.00	\$2,344.00	\$2,344.00
Middle Atlantic	RLNK-915R	15A9 OUTIP CTRL POWER	1.00	\$400.36	\$400.36
Middle Atlantic	EB1	1SP FLANGED ECON BLANK	3.00	\$13.95	\$41.85
Middle Atlantic	UTR1	MOUNTING RACKSHELF, 1 RU, 10"D	1.00	\$53.10	\$53.10
Middle Atlantic	PTRK-14	PORTABLE RACK 14SP	1.00	\$756.20	\$756.20
KCAV	LIFT-RENTAL	Lift Rental / Scaffolding	1.00	\$2,000.00	\$2,000.00
Covid	1LRS-KCAV-006	KCAV VANITY PLATE-1Ru, Flat, BA, KCAV logo w/ 2xRJ45 Port	1.00	\$0.00	\$0.00
KCAV	BUDGET	Contingency Budget	1.00	\$4,000.00	\$4,000.00
KCAV	SHIP-HANDLING	Shipping & Handling of all above items	1.00	\$625.00	\$625.00
QSC	SLQUD-8NP	Q-SYS Core 8 Flex, Core Nano, NV-32-H (Core Capable) UCI Deployment Software License, Perpetual	1.00	\$99.29	\$99.29
QSC	TSC-710t-G3	Table top mounting accessory for TSC-70W-G3 and TSC-101W-G3.	1.00	\$390.00	\$390.00
FSR	DSKB-3G	3 Gang Desktop Mounting Bracket w/ IPS Grommet Kit	1.00	\$114.00	\$114.00
KCAV	CONSUMABLES	Installation Materials	1.00	\$370.90	\$370.90
TOTAL PURCHASED EQUIPMENT					\$19,550.64

INSTALLATION SERVICES

DESCRIPTION	TOTAL PRICE
Commissioning	
Design	
Installation - Onsite	
Programming	
Project Management	
Training	
Travel Time	
TOTAL INSTALLATION SERVICES	
\$20,320.00	

SERVICE COVERAGE

PART NUMBER	MANUFACTURER	PART DESCRIPTION	QTY	UNIT PRICE	TOTAL PRICE
SRV-S1	KCAV	Edge Silver Level Service Agreement; 1-year	1.00	\$2,200.00	\$2,200.00
WARRANTY	KCAV	Workmanship Warranty	1.00	\$0.00	\$0.00
TOTAL SERVICE COVERAGE					\$2,200.00

Subtotal: \$42,070.64
Tax: \$0.00
TOTAL: **\$42,070.64**

DRAFT
- FOR BUDGETARY PURPOSES ONLY -
PLEASE WAIT FOR A FINAL QUOTE TO ISSUE A PO.

GENERAL TERMS AND CONDITIONS

These Terms & Conditions are by and between Kansas City Audio-Visual, Inc. (the "Company") and the undersigned Customer (the "Customer").

- 1. GRANT OF SECURITY INTEREST:** By signing below, Customer acknowledges that this contract serves as a security agreement within the meaning of the Uniform Commercial Code (UCC), and Customer agrees that Company may file such UCC financing statements as are appropriate to perfect Company's security interest in the equipment.
- 2. INSTALLATION:** Customer hereby grants to Company or its agent the right to install the equipment, to the extent such installation is specified above. Customer represents and warrants that all necessary governmental and third-party approvals for installation of the equipment have been obtained, unless otherwise specified. Delays in installation caused by public agencies, manufacturers, suppliers, acts of God, pandemics, strikes or other union bargaining, and all acts not directly attributable to Company, shall not in any way affect the obligations of Customer, and Company's obligations with respect to such installation shall be suspended during the event causing the delay. Company shall not be responsible for damages from any such delay.
- 3. TAXES, FEES, AND PERMITS:** Customer agrees to pay Company all applicable Federal, State, and local taxes, excises, permits, and fees. All dollars in this Agreement are pre-tax, unless otherwise stipulated.
- 4. SHIPPING:** All shipments of equipment are FOB Company's distribution facilities.
- 5. RESPONSIBILITY:** Until balance is paid, Customer agrees to take proper care of the equipment on premises and to be responsible for any damage or loss by fire, theft, casualty, or any other cause whatsoever, and will not permit or suffer same to be removed from the place of its location at address of Customer, without written consent of Company or assigns.
- 6. GENERAL:** This Agreement constitutes the sole and entire understanding between the parties with respect to the subject matter hereof and supersedes all prior conversations, agreements, representations and promises, whether verbal or written. No modification of this Agreement shall be valid, unless made in writing and properly signed by each party. The provisions of this Agreement are severable; if any clause or provision shall be held invalid or unenforceable, in whole or in part, then such invalidity shall attach only to such clause or provision. Customer shall pay all attorneys' fees and other costs and charges incurred by Company in the collection of debt.
- 7. INFRASTRUCTURE:** In the event that Company is installing equipment or systems that require connectivity to the Customer's network including, but not limited to, VOIP connectivity, internet access, wireless network access, firewall traversal, and/or port forwarding, Company may advise Customer as to the network requirements, but any responsibility for infrastructure on the part of Company stops at the installed equipment's network jack or wireless connection and configuration of the network settings on the device sold by Company. Company is not responsible for updating network settings in the event the Customer's network changes. If the Customer's network is not "Plug and Play," then any custom network settings must be supplied by Customer to Company before the start of installation.
- 8. INSTALLATION AND SITE PREPARATION:** Installation (field assembly, interconnection, equipment calibration and checkout) is to be performed by the Company's trained technical employees. The Company shall be entitled to employ subcontractors and/or agents to assist in or carry out, in whole or in part, the installation. In the event installation by Company employees is prevented by trade unions, Customer shall arrange with the trade unions at its own expense to complete installation. The Company is thereafter liable only for supervision of installation.

Company agrees to coordinate with other trades to facilitate satisfactory work progress. If Company's work in progress is impeded by other trades and/or contractors (excluding Company's own subcontractors) or by scheduling delays due to Customer, time delays in the final installation as well as additional charges including labor, travel and reasonable expenses may result.

Customer shall be responsible for preparing, at its own expense, the installation site in accordance with the Company's instructions, including the requirements specified in the proposal. Company shall not be responsible for any high-voltage electrical work, ceiling modifications, structural modifications, or mechanical systems modifications.

Unless otherwise specified, Customer shall provide the Company with source code for any non-Company programmed remote control system required to be modified under the terms of this Agreement.

Customer shall provide the Company with reasonable access to the installation site before delivery, based upon a mutually agreed upon project schedule, for purposes of determining site readiness for installation. Customer will designate an individual on Customer's staff to serve as a contact person for all site preparation and installation issues. Customer shall indemnify the

Company against any loss, damage or claim arising out of the condition of the storage and installation premises.

Customer shall obtain at its expense and keep effective all permissions, licenses, and permits whenever required for the installation and/or use of the equipment and the premises where the equipment shall be situated.

9. LIMITATIONS OF WARRANTY - PRODUCTS OF OTHERS: Unless otherwise specified, no warranty is provided for "consumables," including batteries, lamps, glassware and evacuated devices.

Company's sole obligation with respect to any material or part identified in the quotation, literature, or specifications furnished to the Customer as manufactured or supplied by others, shall be to pass on to Customer the applicable manufacturer's warranties, if any.

10. CHOICE OF LAW AND SEVERABILITY: This agreement shall be interpreted in accordance with and governed in all respects by the law of Missouri. Venue shall be Kansas City, Missouri. Should any provision of this Agreement be found invalid or unenforceable by a court of competent jurisdiction or by operation of any applicable law, it shall not affect the validity of any other provision contained herein.

11. PROJECT/ORDER CANCELLATION: Customer must notify Company via both orders@kcav.com and sales representative in writing to cancel a project or order. Upon receipt of the notice, Company will acknowledge in writing Customer's order cancellation and provide the official date of cancellation. Customer agrees to pay Company for any labor expended or scheduled up to the order cancellation date, including but not limited to engineer time, design time, labor and travel completed, shipping costs, and other expenses related to the order. Assuming the equipment can be returned to the vendor, Customer agrees to pay a 25% restocking fee in addition to any applicable shipping charges. If the vendor will no longer accept the return of the equipment, Customer agrees to be responsible for the full cost of the equipment. Custom items may be noncancellable and are not returnable.

12. RESTOCKING FEES: In the event Customer wishes to return any equipment, Customer agrees to pay restocking fees of 25% of the sale price in addition to any applicable shipping charges.

13. CHANGE ORDERS: Any changes of scope made to the design of the system or the contractual agreements in implementation or functionality will require a mutually agreed upon "Change Order" form signed by an authorized representative for the Customer.

14. TARIFFS: If any products included in the proposal are impacted by international tariff changes, the Company reserves the right to adjust or cancel the proposal.

15. PROFESSIONAL DEVELOPMENT SERVICES: Unless specified otherwise, any purchased training or professional development services must be conducted within 12 months of placement of the sales order, unless mutually agreed upon otherwise in writing. Company will consider any contract to deliver professional development services fulfilled on the date 12 months after placement of sales order.

16. DESIGN SERVICES: All designs are the property of the Company. If Customer contracts with the Company to implement the design, the design shall become the property of Customer. If Customer wants to use the Company's design for an RFP, bid or any other purposes without implementation by the Company, the Company will advise Customer of the fee to purchase the design. Upon payment of the fee, the design becomes the property of Customer.

17. CONFIDENTIALITY: This Agreement and all drawings, specifications, and designs are the property of the Company. Proprietary information provided to Customer (or its agents) is for the sole purpose of demonstrating the Company's capabilities and shall be held in confidence. These materials may not be copied, distributed or disclosed in any way without the sole written permission of an authorized representative of the Company. Any effort to do so will be considered a violation of copyright law.

18. PARAGRAPH HEADINGS: The paragraph headings contained herein are for the convenience of reference only and shall not be construed to affect the interpretation or construction of any substantive provision of this Agreement.

KCAV PROJECT WARRANTY

KCAV offers a 90-day warranty on labor and workmanship, beginning on the date of substantial completion of your project. In the event there is a service issue, and it is determined that the issue is due to project workmanship, KCAV will rectify the issue at no cost to the client. KCAV offers a 90-day warranty on any manufacturer's components included in the project and purchased directly from KCAV. KCAV will work with the manufacturer and client to remove, replace, and reinstall the defective equipment at no charge to the client. KCAV supports the manufacturer's warranty on all hardware. Manufacturer warranties range in time and may be as long as five years. Most manufacturer warranties are based upon depot service. As such, the manufacturer warranty does not cover such items as travel and labor to remove defective equipment, or to reinstall replacement equipment. In the event of a service call which turns out to be related to issues outside of warranty (act of God, user-error, etc.), KCAV will submit an invoice for travel, time, and materials related to the service call. KCAV can provide more information regarding handling of hardware-based warranty situations upon request. KCAV is not responsible for warranty or support of existing Owner Furnished Equipment (OFE).

Maintenance and service agreements are available for extended periods of time. If you have interest in learning more, please contact KCAV at (service@kcav.com) for more information.

KCAV SERVICE OPTIONS

KCAV offers three levels of hourly service, in order to address a full range of situations that require timely, high-quality service of our clients' AV system.

Standard-Level Service

Standard-level service takes place between the hours of 8:00am - 5:00pm, Monday-Friday. Standard-level services requires a minimum of two business days' advance notice for scheduling purposes. While KCAV will make every effort to perform standard service sooner than two days from the client's request, this will not always be possible.

Priority-Level Service

Priority-level service takes place between the hours of 8:00am - 5:00pm, Monday-Friday. Priority-level service will be performed with less than two business days' advance notice. Priority-level service is designed for time-sensitive service needs which do not allow for two or more business days' advance notice.

After-Hours Service

After-hours service takes place outside of 8:00am - 5:00pm, Monday-Friday, and also takes place on federal holidays. After-hours service is designed for service needs which cannot be addressed during standard business hours.

Please note the following which apply to all levels of service provided by KCAV:

- Service time is portal-portal. The time is calculated from the time the service technician departs the KCAV office until the time the service technician returns to the KCAV office.
- A two-hour minimum will be charged for all service calls.
- A dispatch fee is added to each service call to account for the costs of operating the service vehicle.

1. **DELAYS:** All orders are subject to the Company's ability to make delivery at the time specified, and the Company shall not be liable for damages for failure to make partial or complete delivery. The Company shall not be liable for delays in delivery caused by forces not reasonably within Company's control (including but not limited to delays or defaults by carriers, extreme cold weather, floods, fires, storms, or other acts of God, war or act of public enemy or civil disturbance, strikes, lock-outs, shortages of labor or raw materials and supplies, action of any governmental authority, or any other force majeure event). Customer shall be liable for any added expenses incurred by the Company because of, including but not limited to, Customer's delay furnishing requested information to the Company; delays resulting from order changes by Customer; delays related to Customer's network configuration or other systems issues; or conditions affecting installation duration, off-hours or continuous workdays of 8 am to 5 pm.

2. **EQUIPMENT AND MATERIALS PRICE INCREASE:** Company shall be entitled to additional compensation from Customer in the event there is a significant increase in price of any specific item of equipment or materials of seven percent (7%) or more between the date the Agreement is signed and the date that equipment and materials are purchased for the work to be performed on the project.

3. **DELIVERY COSTS & CLAIMS:** Customer agrees to pay for all shipping or transportation costs of the equipment as and if stated on Company's proposal and/or the invoice. Company shall not be liable to Customer for any damage to or loss of equipment in transit. Company's only recourse as to such damage or loss shall be with or against carrier, and all claims must be filed with the carrier. Upon delivery, Customer must inspect and verify that contents match the packing list and are without damage. If there are any discrepancies or damages, Customer must notify Company in writing within three (3) business days, or such claims shall be waived.

4. **HARDWARE-ONLY ORDERS:** Orders over \$50,000 consisting of hardware only require a 50% deposit.

5. **INSTALLATION PROJECTS:** In keeping with industry standards, payment terms for projects over \$50,000 that involve installation are as follows:

- 50% deposit in advance of start of project
- 40% invoiced following delivery of hardware
- 10% remaining invoiced following completion of project

6. **PAYMENT & PAST DUE ACCOUNTS:** All payments are due within thirty (30) days of the invoice date unless an advance deposit is required on Company's quote. A finance charge of the lesser of 1.5% per month (18% - APR) or the highest rate permitted by law will be assessed on all past due accounts. Interest charged on a past due invoice will be assessed from the date of the invoice. Customer agrees to reimburse Company for all attorneys' fees and court costs in connection with default of these payment terms by Customer.

7. **CREDIT & CREDIT CARD PURCHASES:** Credit payment terms must have the prior approval of Company. Company reserves the right to stop delivery of equipment or provision of services if Customer's financial condition becomes impaired or unsatisfactory to the Company. Additionally, Company may require payment in advance or other security, and, in the absence thereof, may cancel, without liability, the unfilled portion of an order. Credit card purchases shall be subject to a four percent (4%) convenience fee where allowed.

PROPOSAL SUMMARY

BILL TO:	SHIP TO:
Raymond Central Public Schools 1800 W Agnew Rd Raymond, NE 68428	Raymond Central Public Schools 1800 W Agnew Rd Raymond, NE 68428

Subtotal: \$42,070.64
Tax: \$0.00
TOTAL: **\$42,070.64**

This Quote shall become binding on the parties hereto when signed by Subscriber and accepted and approved by Kansas City Audio-Visual, Inc.. By Customer's signature, Customer acknowledges that they have read, understood and agreed to Kansas City Audio-Visual, Inc. Terms and Conditions.

CUSTOMER: Raymond Central Public Schools

Kansas City Audio-Visual, Inc.

SIGNATURE: _____

SIGNATURE: _____

NAME: _____

NAME: _____

TITLE: _____

TITLE: _____

DATE: _____

DATE: _____

11.3. Discuss and Consider the School District Report Card

Raymond Central Public Schools

Schools in District	5
State Board District	1
Educational Service Unit	2
Legislative District	21

Demographics



Student Membership
742

Peers
728
State
328,722



Teachers
54

Peers
57
State
23,758

Program Participation



English Learners

Peers
7%
State
8%



Free/Reduced Lunch
19%

Peers
31%
State
50%



Gifted
6%

Peers
11%
State
13%



Special Education
14%

Peers
16%
State
16%

Metrics



Attendance Rate
94%

Peers
95%
State
93%



Dropout Rate

Peers
*
State
1%

* This report masks or hides data for groups with 10 or fewer students to protect confidential information about individual students as required by federal law.

Performance



NSCAS English Language Arts

59%

Peers 66%
State 58%



NSCAS Mathematics

68%

Peers 73%
State 61%



NSCAS Science

78%

Peers 79%
State 70%



ACT (11th Grade)

33% 46% 54%

ELA	Math	Science
Peers 56%	Peers 53%	Peers 60%
State 46%	State 42%	State 49%

Achievement



Graduation Rate

94%

Peers 94%
State 87%



College-Going Rate

67%

Peers 78%
State 73%

Raymond Central Public Schools

Schools in District	5
State Board District	1
Educational Service Unit	2
Legislative District	21

Classification



Beginning Status



SUCCESS, ACCESS, AND SUPPORT

Positive partnerships, Relationships, and Success
In Development!

Transitions

Four-year Graduation	100%
Extended Graduation	95%

AQuESTT uses 2016-2017 graduation rates

Educational Opportunities and Access

Chronic Absenteeism Reduction	No
Progress Towards EL Proficiency	N/A

Evidence-Based Analysis
 Not eligible for Adjustment
 EBA Total Score 0 / 120

TEACHING, LEARNING, AND SERVING

College, Career, and Civic Ready
In Development!

Assessment

Individual Score Growth	60%
Score Improvement	N/A
Non-Proficiency Reduction	Yes
Science Proficiency Status	71%
Science Score Improvement	N/A

Educator Effectiveness
In Development!

Final AQuESTT Classification



Raymond Central Public Schools

Schools in District	5
State Board District	1
Educational Service Unit	2
Legislative District	21



Raymond Central Public Schools

1800 W AGNEW RD
RAYMOND, NE 68428-9783



(402)785-2615



(402)785-2097



55-0161-000

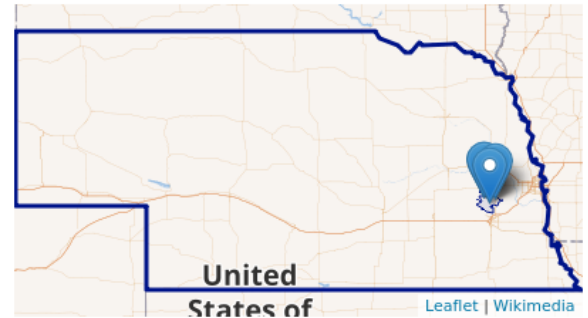

District Description

Raymond Central is a consolidated public school district incorporating the communities of Davey, Raymond, Agnew, Ceresco and Valparaiso. Two elementary centers, K-5 at Ceresco and K-5 at Valparaiso. RC Jr-Sr High School is a comprehensive 7-12 school that strives to meet the varied needs of a wide range of students who have both agricultural and more urban/suburban backgrounds. The HS site also hosts a 6th grade "Intermediate" transition program which includes departmentalization of curriculum, and the PK program for 3-4 year old students. The elementary school program has been recognized as a US Dept of Education Blue Ribbon School of Excellence and includes some Nebraska "Teacher of the Year" finalists. The secondary program features award winning speech, music, art, FBLA, FFA and SkillsUSA. Our staff provides students strong academic preparation and innovative teaching. Effective learning is a hallmark of Raymond Central Schools evidenced by high academic achievement.

This description was provided by the district

11.4. Discuss, Consider and Take Necessary Action to approve the purchase of heat pumps for Valparaiso elementary

QUOTATION

Date: 1/5/2024
Project: Valparaiso Elementary – WSHP Budgets
Quote #: Q24-0023

To: Raymond Central
Attn: Jared Shanahan

Bid Date: 1/5/2024
Engineer: NA
Location: Valparaiso, NE
Quoted By: Brad McKewon

Daikin WSHP Sizing:

HP-2 Replacement – QTY of 1

- WGCH019
- 265/60/1

TOTAL NET PRICE – FOB Factory, Full Freight Allowed **\$4,298.00**

HP-3 Replacement – QTY of 1

- WGCH030
- 265/60/1

TOTAL NET PRICE – FOB Factory, Full Freight Allowed **\$4,880.00**

HP-4 Replacement – QTY of 1

- WGCH036
- 460/60/3

TOTAL NET PRICE – FOB Factory, Full Freight Allowed **\$5,880.00**

HP-5 Replacement – QTY of 1

- WGCH048
- 460/60/3

TOTAL NET PRICE – FOB Factory, Full Freight Allowed **\$6,632.00**

This quotation, provided by Mechanical Sales, Inc., is valid for a period of 30 days from the date of issue. The acceptance of this quote implies agreement to adhere to Mechanical Sales, Inc.'s standard terms and conditions as outlined on our official website: www.mechsales.com/terms-and-conditions

By accepting this quotation, you acknowledge and agree to comply with the terms and conditions specified on our website. Any deviations from the standard terms and conditions must be agreed upon in writing and may affect the validity of this quotation.



QUOTATION

Date: 1/5/2024
Project: Valparaiso Elementary – WSHP Budgets
Quote #: Q24-0023

HP-6 Replacement – QTY of 1

- WGCH060
- 460/60/3

TOTAL NET PRICE – FOB Factory, Full Freight Allowed **\$6,980.00**

HP-7 Replacement – QTY of 1

- WGCH060
- 460/60/3

TOTAL NET PRICE – FOB Factory, Full Freight Allowed **\$6,980.00**

HP-8 Replacement – QTY of 1

- WGCH070
- 460/60/3

TOTAL NET PRICE – FOB Factory, Full Freight Allowed **\$7,765.00**

HP-9 Replacement – QTY of 1

- WCCW2120
- 460/60/3

TOTAL NET PRICE – FOB Factory, Full Freight Allowed **\$15,900.00**

NOTE: All Unit Pricing Above Includes:

- 3 ft. Supply/Return Hose
- 4 Year Refrigerant Circuit Warranty
- BACnet Communication Module

This quotation, provided by Mechanical Sales, Inc., is valid for a period of 30 days from the date of issue. The acceptance of this quote implies agreement to adhere to Mechanical Sales, Inc.'s standard terms and conditions as outlined on our official website: www.mechsales.com/terms-and-conditions

By accepting this quotation, you acknowledge and agree to comply with the terms and conditions specified on our website. Any deviations from the standard terms and conditions must be agreed upon in writing and may affect the validity of this quotation.





High Efficiency Horizontal Water Source Heat Pump & Cooling Only Units

Submittal Drawing

D-30

Sizes 014, 020

Mammoth Inc. certifies that it will furnish equipment in accordance with this drawing and specifications, and subject to its published warranty. Purchaser's approval of this drawing signifies that the equipment is acceptable under the provisions of the job specifications. Any change made hereon by any person whomsoever is subject to acceptance by Mammoth Inc., 101 W. 82nd Street, Chaska, MN. 55318.

General Specifications

CABINET - Outer casing of G-90 galvanized steel.
REFRIGERANT CIRCUIT - Hermetic including reversing valve, thermal expansion valve, and high/low side access valves.
COMPRESSOR - Hermetic type with PSC or three phase motor, overload protection and mounted on neoprene isolators.
AIR COIL - Seamless copper tubes and aluminum fins.
WATER-TO-REFRIGERANT COIL - Tube-in-tube type with steel outer tube and copper inner tube.
FILTER - One inch thick throwaway.
INSULATION - 1/2" thick, 1 1/2 lb. multi-density fiberglass.

FAN - Centrifugal type with forward curved wheel.
FAN MOTOR - Multiple speed PSC type with sleeve bearing, integral rubber mounts and inherent overload protection.
ELECTRICAL - 24 volt control system with fan relay, compressor contactor, reversing valve coil, 50 VA transformer, lockout relay with high and low pressure refrigerant safety switches.
CONTROL - Field-mounted 24 volt wall-mount type thermostat with automatic or manual changeover control.

Dimensional Data

UNIT SIZE	OPERATING WEIGHT- lbs (kg)	SHIPPING WEIGHT-lbs (kg)
014	140 (63.5)	155 (70.3)
020	155 (70.3)	170 (77.1)

Filter Size: (1) 16" x 20"

UNIT SIZE	A	B	C	D
014	7.00 (178)	2.38 (60)	10.25 (260)	14.75 (375)
020	8.25 (210)	2.60 (66)	10.25 (260)	17.25 (438)

All dimensions are inches (millimeters).

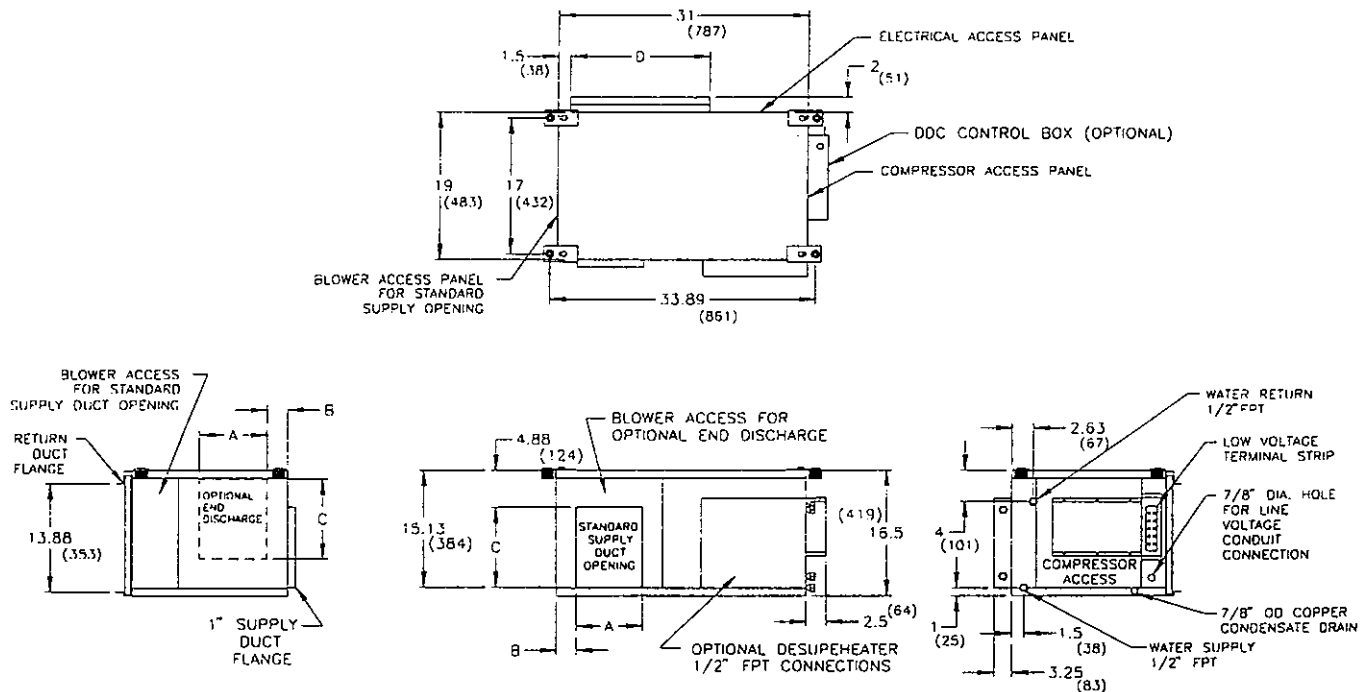

Electrical Data

UNIT SIZE	VOLTAGE	COMPRESSOR		FAN MOTOR FLA	TOTAL AMPS	MINIMUM/MAXIMUM VOLTS	MINIMUM CIRCUIT AMPACITY	MAXIMUM BREAKER SIZE	MAXIMUM FUSE SIZE
		RLA	LRA						
A014HHE,HLE	115/60/1	11.4	67.0	1.7	13.1	104/126	16.0	27.4	25
D014HHE,HLE	208-230/60/1	5.4	29.0	.7	6.1	197/253	7.5	12.9	15
E014HHE,HLE	265/60/1	4.8	27.0	.7	5.5	239/291	6.7	11.5	15
D020HHF,HLF	208-230/60/1	9.6	45.0	1.7	11.3	197/253	13.7	23.3	20
E020HHF,HLF	265/60/1	7.7	39.0	1.7	9.4	239/291	11.3	19.0	15

208-230 volt units are shipped for 208 volt operation. For 230 volt operation, change the red tap on the transformer to the orange tap.

NOTE: Fuse protection must be dual element, time delay (Class RK5) type or HACR circuit breaker.

HP-2

Hanger Bracket Detail

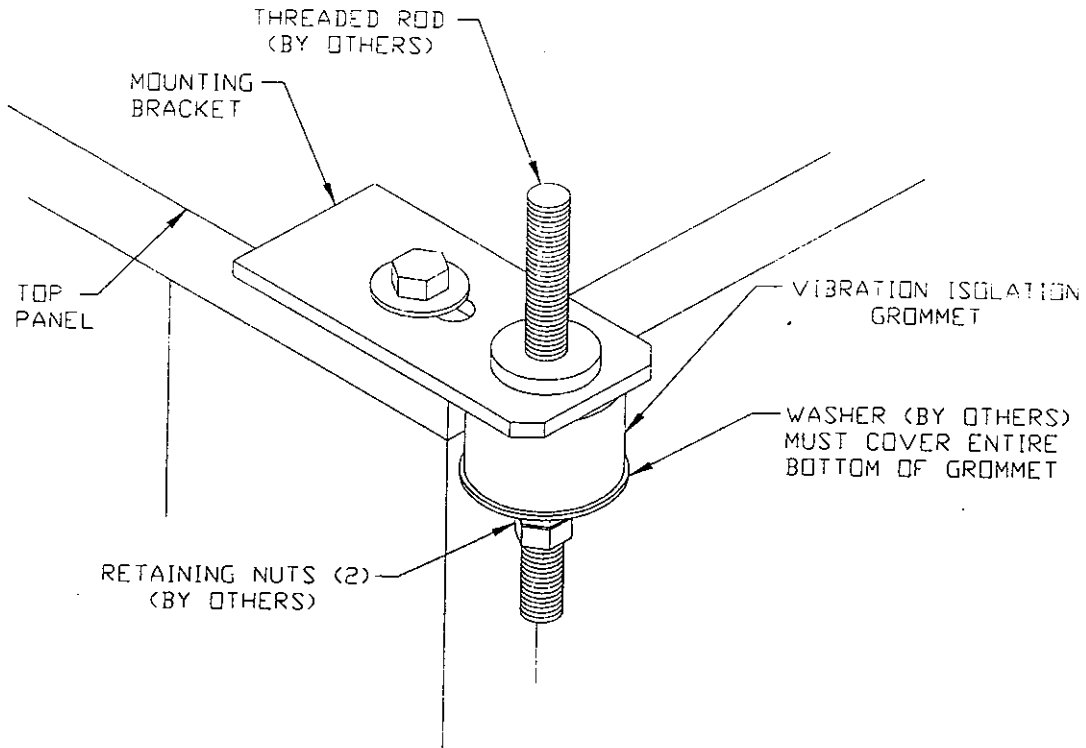

1" and 2" Thick Filter Rack/ Return Air Duct Collar

All dimensions are inches (millimeters).

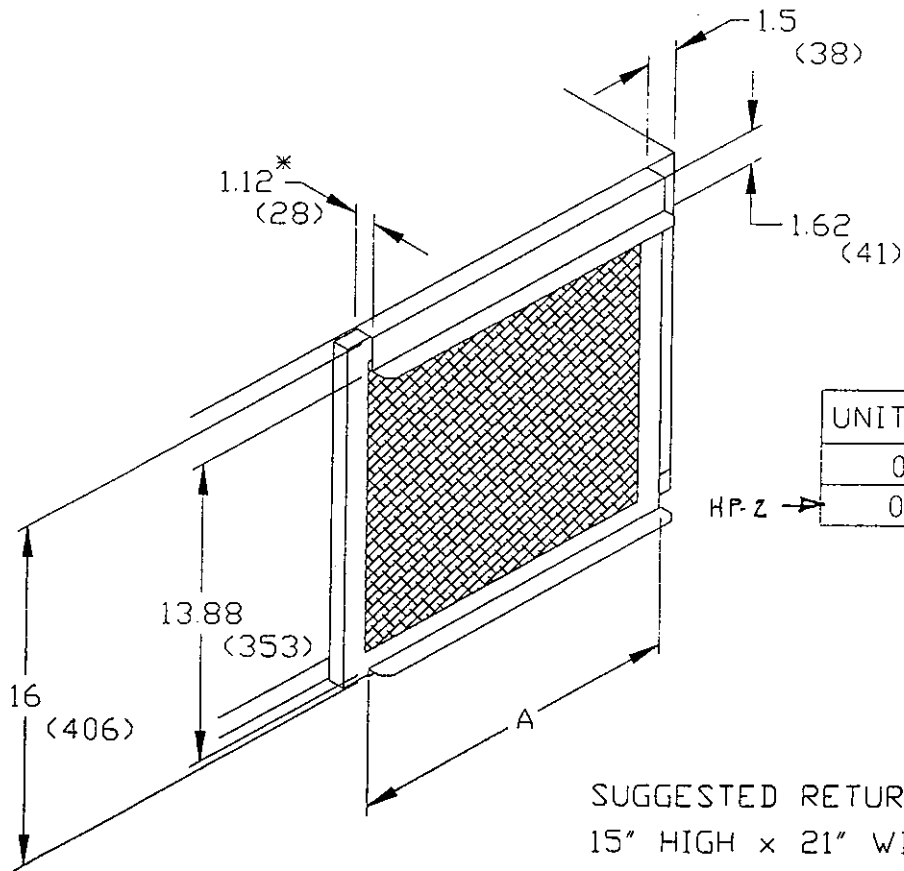

UNIT SIZE	A
014	14.75 (375)
020	17.25 (438)

SUGGESTED RETURN AIR DUCT SIZE:
15" HIGH x 21" WIDE

* 2.24" (57) FOR OPTIONAL 2" THICK FILTER RACK.



High Efficiency Horizontal Water Source Heat Pump & Cooling Only Units

Submittal Drawing

D-31

Size 027

Mammoth Inc. certifies that it will furnish equipment in accordance with this drawing and specifications, and subject to its published warranty. Purchaser's approval of this drawing signifies that the equipment is acceptable under the provisions of the job specifications. Any change made hereon by any person whomsoever is subject to acceptance by Mammoth Inc., 101 W. 82nd Street, Chaska, MN. 55318.

General Specifications

CABINET - Outer casing of G-90 galvanized steel.
REFRIGERANT CIRCUIT - Hermetic including reversing valve, thermal expansion valve, and high/low side access valves.
COMPRESSOR - Hermetic type with PSC or three phase motor, overload protection and mounted on neoprene isolators.
AIR COIL - Seamless copper tubes and aluminum fins.
WATER-TO-REFRIGERANT COIL - Tube-in-tube type with steel outer tube and copper inner tube.
FILTER - One inch thick throwaway.
INSULATION - 1/2" thick, 1 1/2 lb. multi-density fiberglass.

FAN - Centrifugal type with forward curved wheel.
FAN MOTOR - Multiple speed PSC type with sleeve bearing, integral rubber mounts and inherent overload protection.
ELECTRICAL - 24 volt control system with fan relay, compressor contactor, reversing valve coil, 50 VA transformer, lockout relay with high and low pressure refrigerant safety switches.
CONTROL - Field-mounted 24 volt wall-mount type thermostat with automatic or manual changeover control.

Dimensional Data

SIZE	OPERATING WEIGHT- lbs (kg)	SHIPPING WEIGHT- lbs (kg)
027	220 (99.8)	240 (108.9)

Filter Size: (1) 18" x 25"

All dimensions are inches (millimeters).

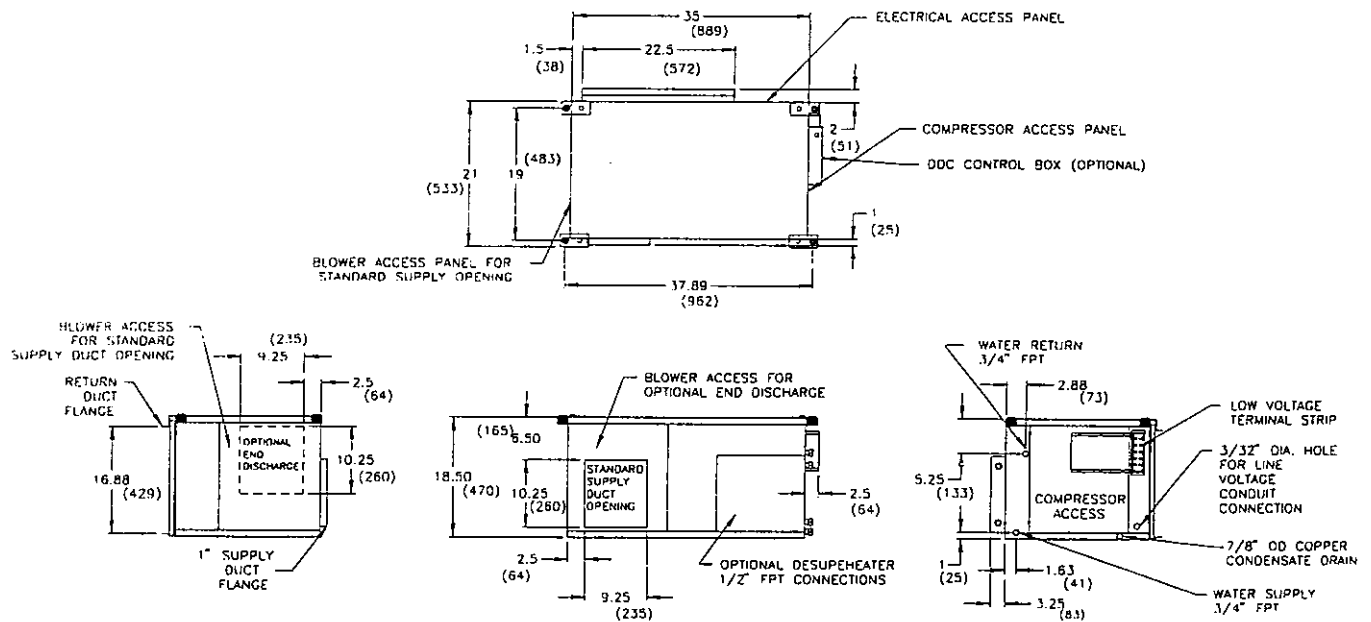

Electrical Data

UNIT SIZE	VOLTAGE	COMPRESSOR		FAN MOTOR FLA	TOTAL AMPS	MINIMUM/MAXIMUM VOLTS	MINIMUM CIRCUIT AMPACITY	MAXIMUM BREAKER SIZE	MAXIMUM FUSE SIZE
		RLA	LRA						
D027HHF,HLF	208-230/60/1	12.2	61.0	2.4	14.6	197/253	17.7	29.9	25
E027HHF,HLF	265/60/1	10.3	58.0	1.8	12.1	239/291	14.6	24.9	20
F027HHF,HLF	208-230/60/3	8.6	55.0	2.4	11.0	197/253	13.2	21.8	20
G027HHF,HLF	460/60/3	4.3	27.0	1.0	5.3	239/291	6.4	10.7	15

208-230 volt units are shipped for 208 volt operation. For 230 volt operation, change the red tap on the transformer to the orange tap.
 NOTE: Fuse protection must be dual element, time delay (Class RK5) type or HACR circuit breaker.

HP-3

Hanger Bracket Detail

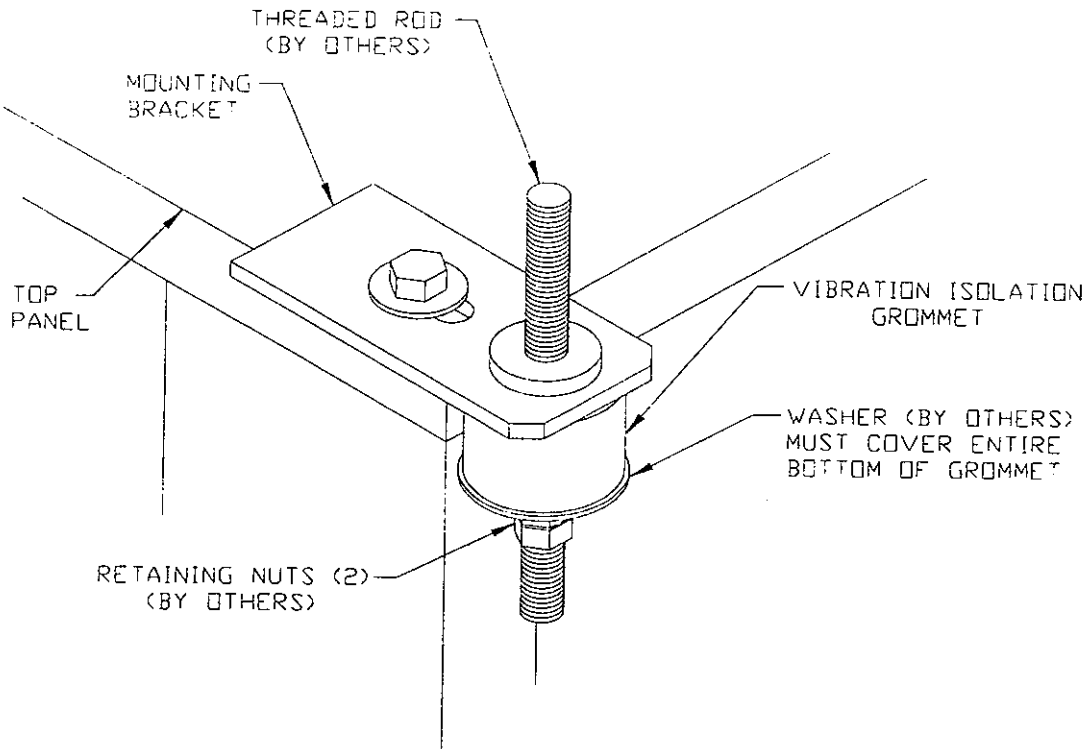

1" and 2" Thick Filter Rack/ Return Air Duct Collar

All dimensions are inches (millimeters).

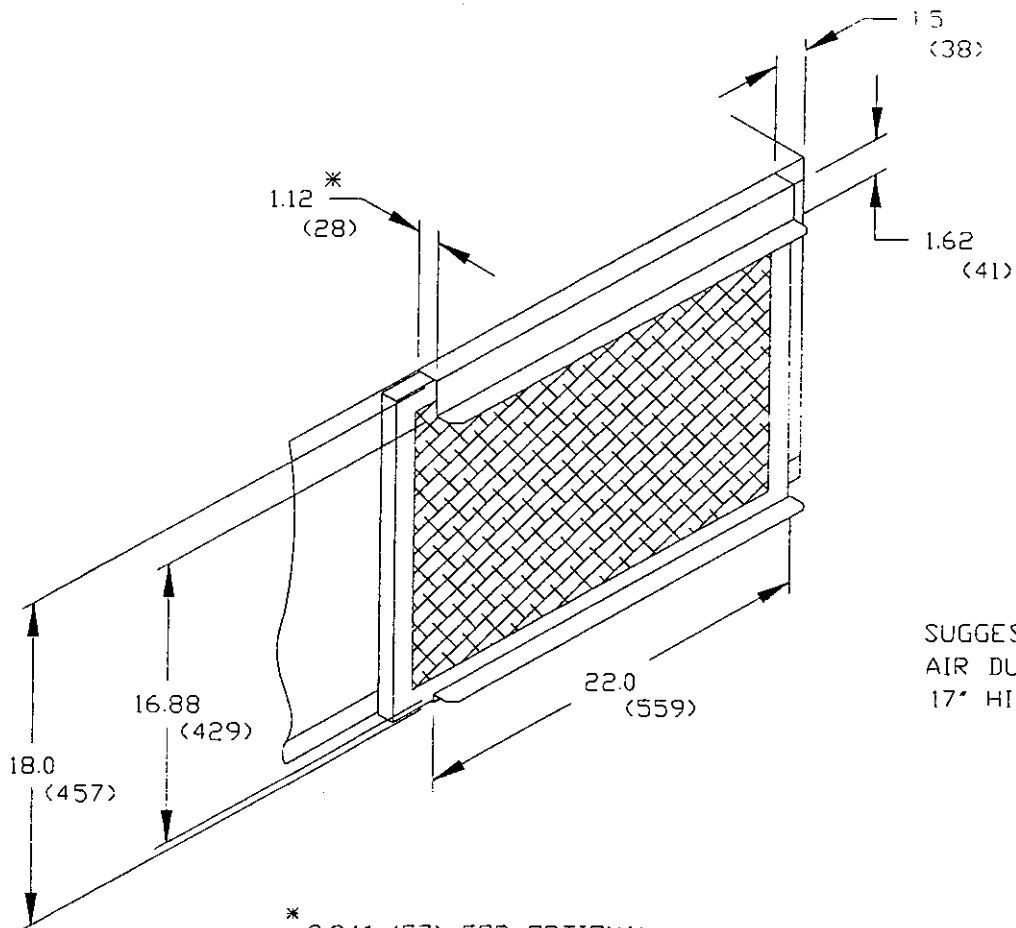

SUGGESTED RETURN AIR DUCT SIZE:
17" HIGH x 26" WIDE

* 2.24" (57) FOR OPTIONAL 2" THICK FILTER RACK.



High Efficiency Horizontal Water Source Heat Pump & Cooling Only Units

Submittal Drawing

D-32

Sizes 035, 045, 054, 064

Mammoth Inc. certifies that it will furnish equipment in accordance with this drawing and specifications, and subject to its published warranty. Purchaser's approval of this drawing signifies that the equipment is acceptable under the provisions of the job specifications. Any change made hereon by any person whomsoever is subject to acceptance by Mammoth Inc., 101 W. 82nd Street, Chaska, MN. 55318.

General Specifications

CABINET - Outer casing of G-90 galvanized steel.
REFRIGERANT CIRCUIT - Hermetic including reversing valve, thermal expansion valve, and high/low side access valves.
COMPRESSOR - Hermetic type with PSC or three phase motor, overload protection and mounted on neoprene isolators.
AIR COIL - Seamless copper tubes and aluminum fins.
WATER-TO-REFRIGERANT COIL - Tube-in-tube type with steel outer tube and copper inner tube.
FILTER - One inch thick throwaway.
INSULATION - 1/2" thick, 1 1/2 lb. multi-density fiberglass.

FAN - Centrifugal type with forward curved wheel.
FAN MOTOR - Multiple speed PSC type with sleeve bearing, integral rubber mounts and inherent overload protection.
ELECTRICAL - 24 volt control system with fan relay, compressor contactor, reversing valve coil, 50 VA transformer, lockout relay with high and low pressure refrigerant safety switches.
CONTROL - Field-mounted 24 volt wall-mount type thermostat with automatic or manual changeover control.

Dimensional Data

UNIT SIZE	OPERATING WEIGHT lbs (kg)	SHIPPING WEIGHT-lbs (kg)
035	275 (124.7)	295 (133.8)
045	295 (133.8)	315 (142.9)
054	310 (140.6)	330 (149.7)
064	325 (147.4)	345 (156.5)

UNIT SIZE	A	B	C	D
035	9.25 (235)	10.25 (260)	9.00 (229)	4.00 (102)
045	10.63 (270)	11.50 (292)	7.87 (200)	2.50 (64)
054	10.63 (270)	11.50 (292)	7.87 (200)	2.50 (64)
064	10.63 (270)	11.50 (292)	7.87 (200)	2.50 (64)

Filter Size: (1) 20" x 32"

All dimensions are inches (millimeters).

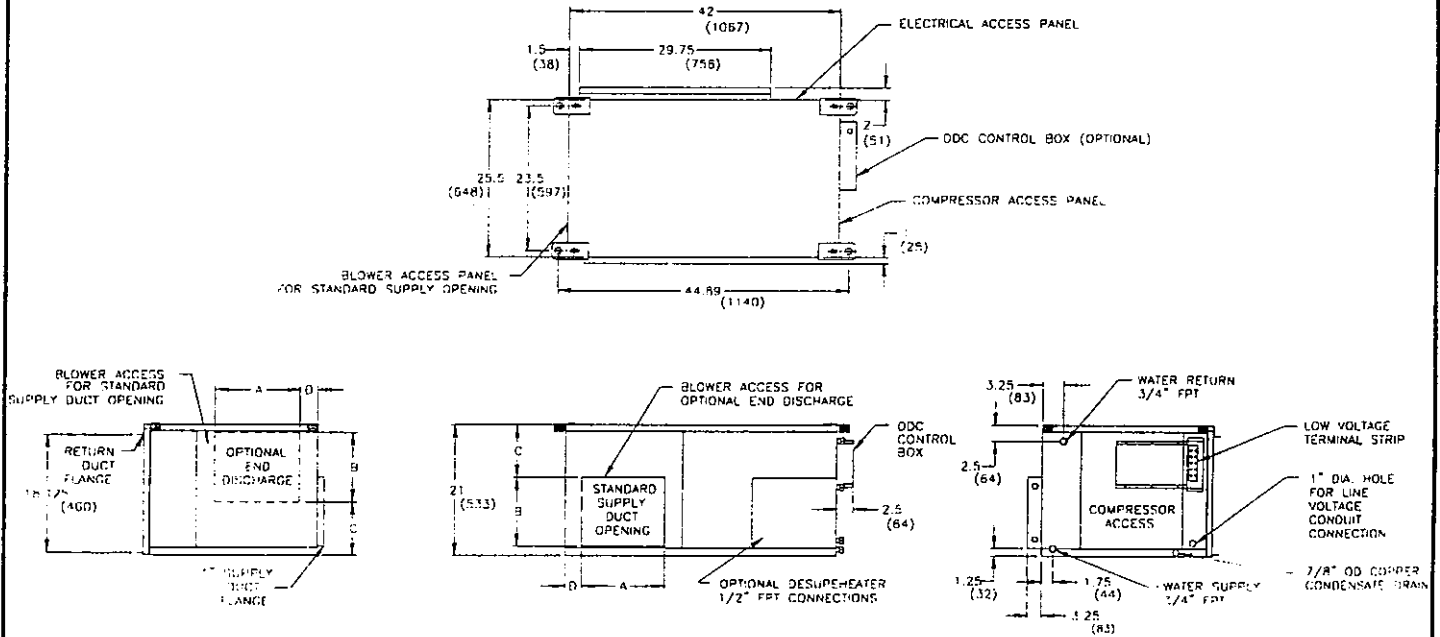

Electrical Data

UNIT SIZE	VOLTAGE	COMPRESSOR		FAN MOTOR FLA	TOTAL AMPS	MINIMUM/MAXIMUM VOLTS	MINIMUM CIRCUIT AMPACITY	MAXIMUM BREAKER SIZE	MAXIMUM FUSE SIZE
		RLA	LRA						
D035HHE,HLE	208-230/60/1	16.1	88.0	2.4	18.5	197/253	22.5	38.6	35
E035HHE,HLE	265/60/1	12.8	75.0	2.4	15.2	239/291	18.4	31.2	30
F035HHE,HLE	208-230/60/3	10.2	77.0	2.4	12.6	239/291	15.2	25.4	25
G035HHE,HLE	460/60/3	5.0	39.0	1.0	6.0	414/506	7.3	12.3	15
D045HHF,HLF	208-230/60/1	17.9	104.0	3.2	21.1	197/253	25.6	43.5	40
F045HHF,HLF	208-230/60/3	12.5	88.0	3.2	15.7	187/253	18.8	31.3	30
G045HHF,HLF	460/60/3	5.7	44.0	1.8	7.5	414/506	8.9	14.6	15
D054HHE,HLE	208-230/60/1	23.7	129.0	5.2	28.9	197/253	34.8	58.5	50
F054HHE,HLE	208-230/60/3	13.5	99.0	5.2	18.7	187/253	22.1	35.6	35
G054HHE,HLE	460/60/3	7.4	49.5	2.5	9.9	414/506	11.8	19.2	15
K054HHE,HLE	575/60/3	5.7	40.0	2.0	7.7	515/632	9.1	14.8	15
D064HHF,HLF	208-230/60/1	28.8	169.0	5.2	34.0	197/253	41.2	70.0	70
F064HHF,HLF	208-230/60/3	17.3	123.0	5.2	22.5	187/253	26.8	44.1	40
G064HHF,HLF	460/60/3	9.0	62.0	2.5	11.5	414/506	13.8	22.8	20
K064HHF,HLF	575/60/3	7.1	50.0	2.0	9.1	515/632	10.9	18.0	15

208-230 volt units are shipped for 208 volt operation. For 230 volt operation, change the red tap on the transformer to the orange tap.

NOTE: Fuse protection must be dual element, time delay (Class RK5) type or HACR circuit breaker.

Hanger Bracket Detail

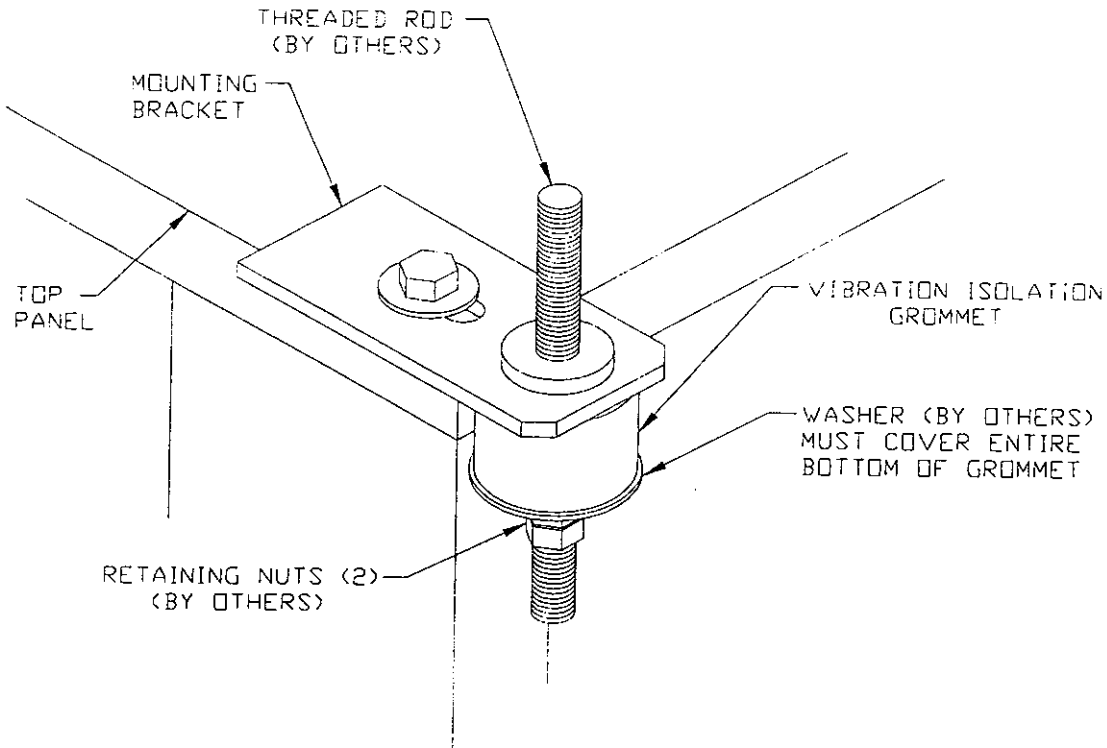

1" and 2" Thick Filter Rack/ Return Air Duct Collar

All dimensions are inches (millimeters).

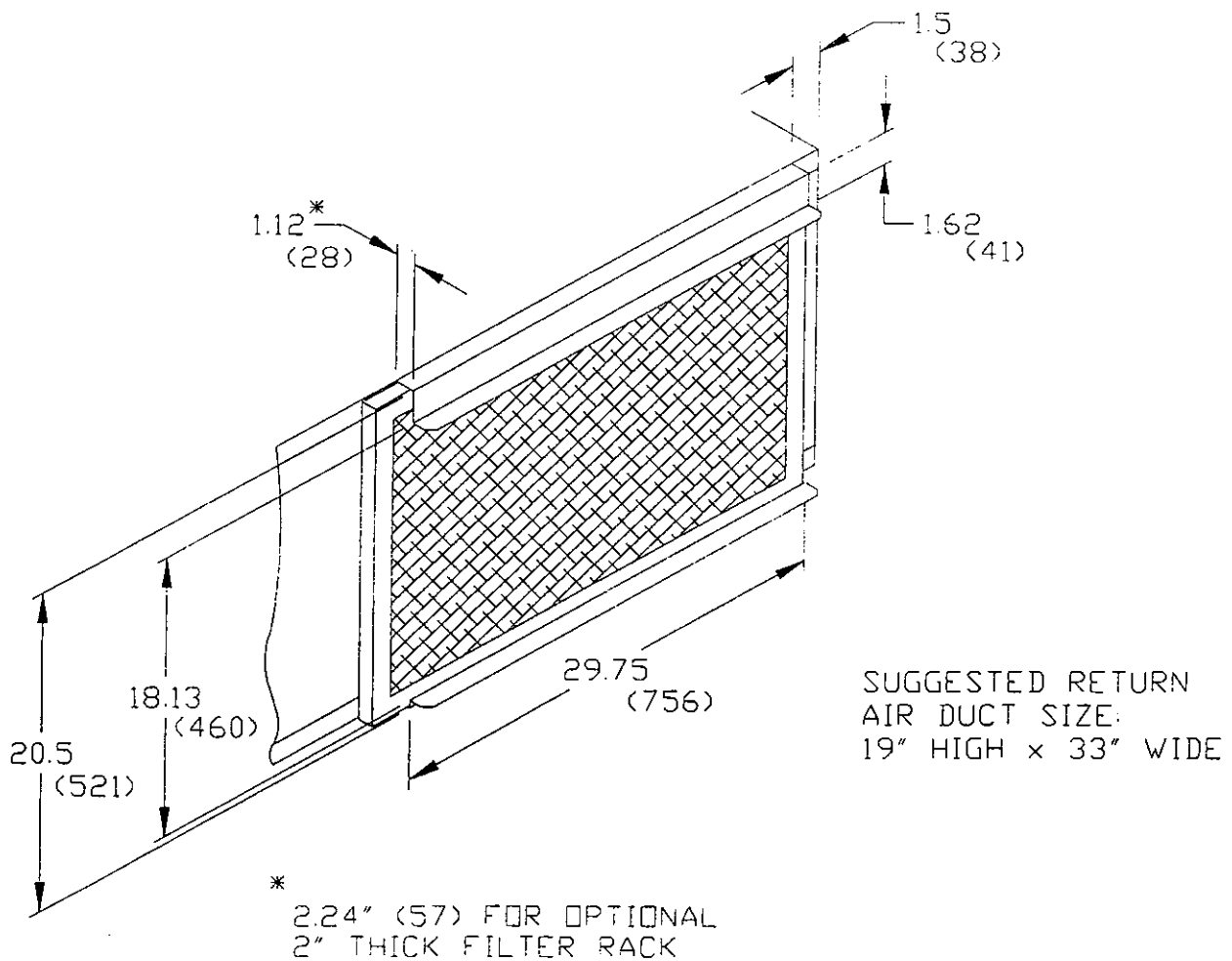



High Efficiency Mirror Image Horizontal Heat Pump & Cooling Only Units

Submittal Drawing
D-37
Sizes 035, 045, 054, 064

Mammoth Inc. certifies that it will furnish equipment in accordance with this drawing and specifications, and subject to its published warranty. Purchaser's approval of this drawing signifies that the equipment is acceptable under the provisions of the job specifications. Any change made hereon by any person whomsoever is subject to acceptance by Mammoth Inc., 101 W. 82nd Street, Chaska, MN. 55318.

General Specifications

CABINET - Outer casing of G-90 galvanized steel.
REFRIGERANT CIRCUIT - Hermetic including reversing valve, thermal expansion valve, and high/low side access valves.
COMPRESSOR - Hermetic type with PSC or three phase motor, overload protection and mounted on neoprene isolators.
AIR COIL - Seamless copper tubes and aluminum fins.
WATER-TO-REFRIGERANT COIL - Tube-in-tube type with steel outer tube and copper inner tube.
FILTER - One inch thick throwaway.
INSULATION - 1/2" thick, 1 1/4 lb. multi-density fiberglass.

FAN - Centrifugal type with forward curved wheel.
FAN MOTOR - Multiple speed PSC type with sleeve bearing, integral rubber mounts and inherent overload protection.
ELECTRICAL - 24 volt control system with fan relay, compressor contactor, reversing valve coil, 50 VA transformer, lockout relay with high and low pressure refrigerant safety switches.
CONTROL - Field-mounted 24 volt wall-mount type thermostat with automatic or manual changeover control.

Dimensional Data

UNIT SIZE	OPERATING WEIGHT-lbs (kg)	SHIPPING WEIGHT-lbs (kg)
035	275 (124.7)	295 (133.8)
045	295 (133.8)	315 (142.9)
054	310 (140.6)	330 (149.7)
064	325 (147.4)	345 (156.5)

UNIT SIZE	A	B	C	D
035	9.25 (235)	10.25 (260)	1.75 (44)	4.00 (102)
045	10.63 (270)	11.50 (292)	1.63 (41)	2.50 (64)
054	10.63 (270)	11.50 (292)	1.63 (41)	2.50 (64)
064	10.63 (270)	11.50 (292)	1.63 (41)	2.50 (64)

Filter Size: (1) 20" x 32"

All dimensions are inches(millimeters).

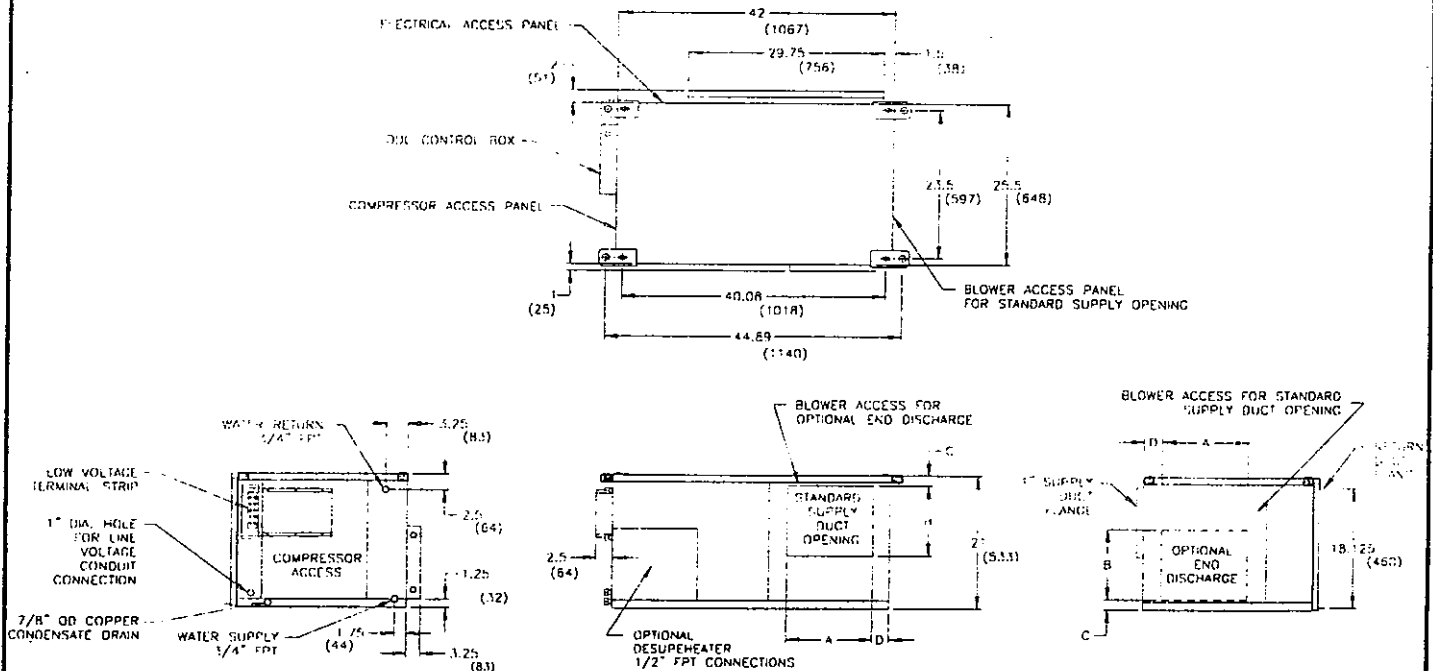

Electrical Data

UNIT SIZE	VOLTAGE	COMPRESSOR		FAN MOTOR FLA	TOTAL AMPS	MINIMUM/MAXIMUM VOLTS	MINIMUM CIRCUIT AMPACITY	MAXIMUM BREAKER SIZE	MAXIMUM FUSE SIZE
		RLA	LRA						
D035HHE,HLE	208-230/60/1	16.1	88.0	2.4	18.5	197/253	22.5	38.6	35
E035HHE,HLE	265/60/1	12.8	75.0	1.7	14.5	239/291	17.7	30.5	30
F035HHE,HLE	208-230/60/3	10.2	77.0	2.4	12.6	239/291	15.2	25.4	25
G035HHE,HLE	460/60/3	5.1	39.0	1.0	6.1	414/506	7.4	12.5	15
D045HHF,HLF	208-230/60/1	17.9	104.0	4.9	22.8	197/253	27.3	45.2	45
F045HHF,HLF	208-230/60/3	12.5	88.0	4.9	17.4	187/253	20.5	33.0	30
HP-5 → G045HHF,HLF	460/60/3	5.7	44.0	1.8	7.5	414/506	8.9	14.6	15
D054HHE,HLE	208-230/60/1	23.7	129.0	5.3	29.0	197/253	34.9	58.6	50
F054HHE,HLE	208-230/60/3	13.5	99.0	5.3	18.8	187/253	22.2	35.7	35
G054HHE,HLE	460/60/3	7.4	49.5	2.6	10.0	414/506	11.9	19.3	15
K054HHE,HLE	575/60/3	5.7	40.0	2.4	8.1	515/632	9.5	15.2	15
D064HHF,HLF	208-230/60/1	28.8	169.0	5.3	34.1	197/253	41.3	70.1	70
F064HHF,HLF	208-230/60/3	17.3	123.0	5.3	22.6	187/253	26.9	44.2	40
HP-7 → G064HHF,HLF	460/60/3	9.0	62.0	2.6	11.6	414/506	13.9	22.9	20
K064HHF,HLF	575/60/3	7.1	50.0	2.4	9.5	515/632	11.3	18.4	15

208-230 volt units are shipped for 208 volt operation. For 230 volt operation, change the red tap on the transformer to the orange tap.
 NOTE: Fuse protection must be dual element, time delay (Class RK5) type or HACR circuit breaker.

Hanger Bracket Detail

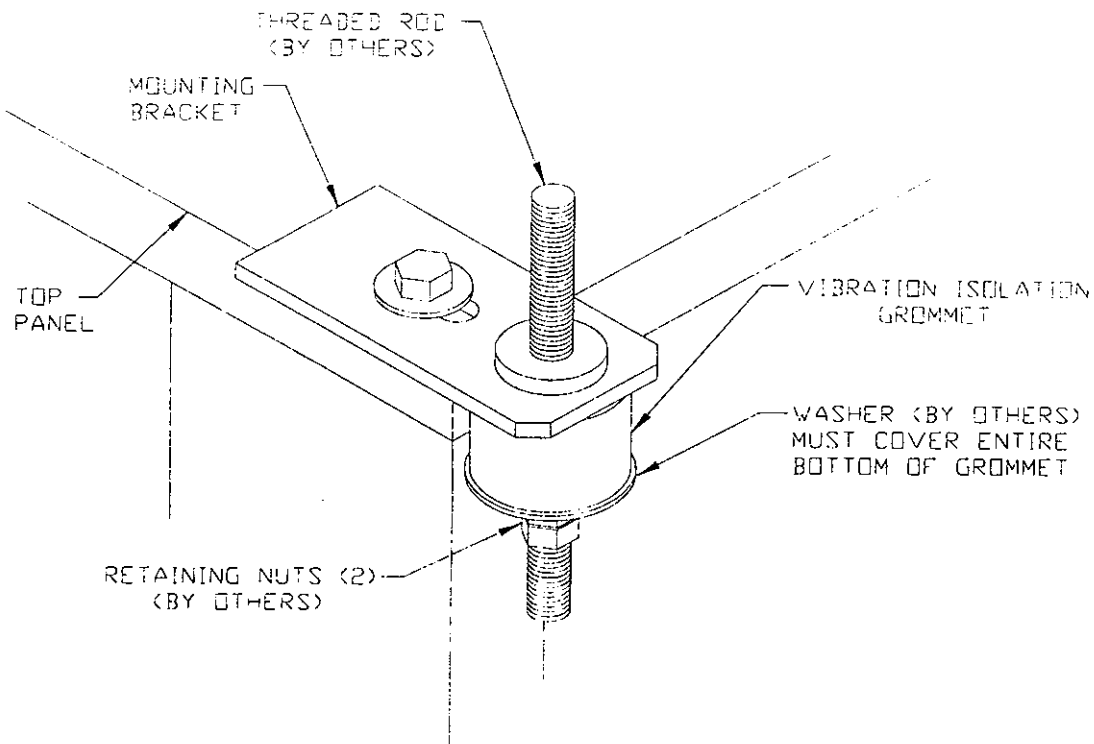

1" and 2" Thick Filter Rack/ Return Air Duct Collar

All dimensions are inches (millimeters).

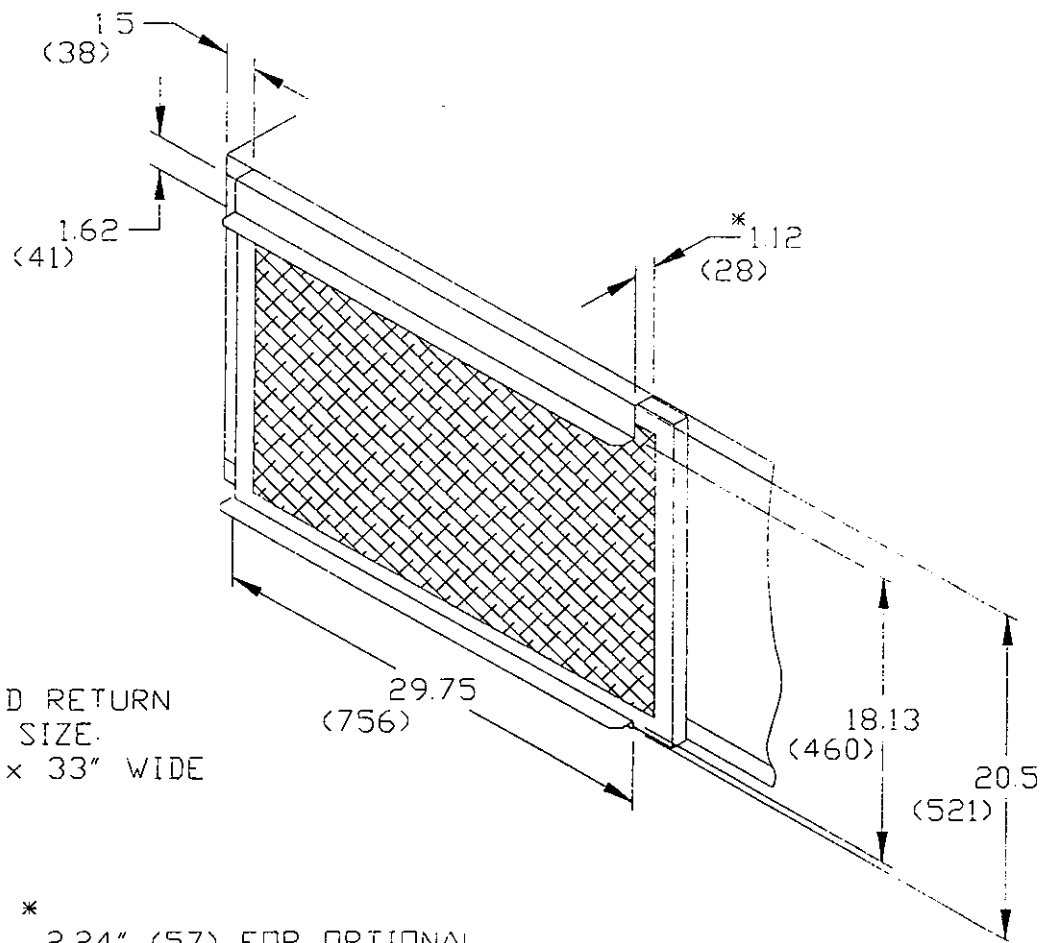

SUGGESTED RETURN AIR DUCT SIZE:
19" HIGH x 33" WIDE

* 2.24" (57) FOR OPTIONAL 2" THICK FILTER RACK



Mammoth Inc.

High Efficiency Horizontal Water Source Heat Pump & Cooling Only Units

Submittal Drawing

D-33

Sizes 070, 090, 110, 130

Mammoth Inc. certifies that it will furnish equipment in accordance with this drawing and specifications, and subject to its published warranty. Purchaser's approval of this drawing signifies that the equipment is acceptable under the provisions of the job specifications. Any change made hereon by any person whomsoever is subject to acceptance by Mammoth Inc., 101 W. 82nd Street, Chaska, MN. 55318.

General Specifications

CABINET - Outer casing of G-90 galvanized steel.
REFRIGERANT CIRCUITS - Hermetic including reversing valve, thermal expansion valve, and high/low side access valves.
COMPRESSOR - Hermetic type with PSC or three phase motor, overload protection and mounted on neoprene isolators.
AIR COIL - Seamless copper tubes and aluminum fins.
WATER-TO-REFRIGERANT COIL - Tube-in-tube type with steel outer tube and copper inner tube.
FILTER - One inch thick throwaway.
INSULATION - 3/4" thick, 1 1/2 lb. multi-density fiberglass.

FAN - Belt-driven centrifugal type with forward curved wheel.
FAN MOTOR - Three phase with overload protection, integral rubber mounts and inherent overload protection.
ELECTRICAL - 24 volt control system with fan relay, compressor contactor, reversing valve coil, 75 VA transformer, lockout relay with high and low pressure refrigerant safety switches.
CONTROL - Field-mounted 24 volt wall-mount type thermostat with automatic or manual changeover control.

Dimensional Data

UNIT SIZE	OPERATING WEIGHT lbs (kg)	SHIPPING WEIGHT-lbs (kg)
070	650 (294.8)	675 (306.2)
090	710 (322.0)	735 (333.4)
110	730 (331.1)	755 (342.5)
130	750 (340.2)	775 (351.5)

Filter Size: (2) 20" x 30"

UNIT SIZE	A	B	C
070	13.00 (330)	21.75 (522)	15.00 (381)
090	13.00 (330)	21.75 (522)	15.00 (381)
110	14.75 (375)	20.00 (508)	16.00 (406)
130	14.75 (375)	20.00 (508)	16.00 (406)

All dimensions are inches(millimeters).

HP-8
HP-9

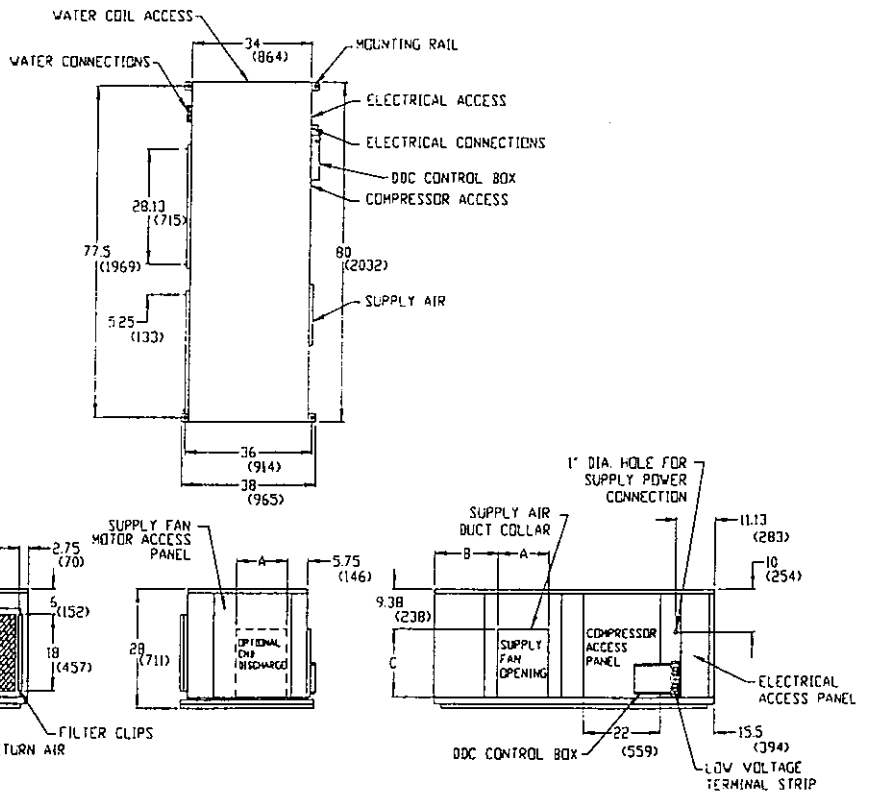

Electrical Data

UNIT SIZE	FAN MOTOR HP	VOLTAGE	COMPRESSOR		FAN MOTOR FLA	TOTAL AMPS	MINIMUM/MAXIMUM VOLTS	MINIMUM CIRCUIT AMPACITY	MAXIMUM BREAKER SIZE	MAXIMUM FUSE SIZE
			RLA	LRA						
F070HHF,HLF	1.0	208-230/60/3	10.2	77.0	3.6	24.0	187/253	26.6	36.8	35
P-B → G070HHF,HLF	1.0	460/60/3	5.0	39.0	1.8	11.8	414/506	13.1	18.1	15
K070HHF,HLF	1.0	575/60/3	4.7	31.0	1.5	10.9	515/632	12.1	16.8	15
F070HHF,HLF	2.0	208-230/60/3	10.2	77.0	7.0	27.4	187/253	30.0	40.2	40
G070HHF,HLF	2.0	460/60/3	5.0	39.0	3.5	13.5	414/506	14.8	19.8	15
K070HHF,HLF	2.0	575/60/3	4.7	31.0	2.5	11.9	515/632	13.1	17.8	15
F090HHF,HLF	1.0	208-230/60/3	12.5	88.0	3.6	28.6	187/253	31.7	44.2	40
G090HHF,HLF	1.0	460/60/3	5.7	44.0	1.8	13.2	414/506	14.6	20.3	20
K090HHF,HLF	1.0	575/60/3	4.8	34.0	1.5	11.1	515/632	12.3	17.1	15
F090HHF,HLF	2.0	208-230/60/3	12.5	88.0	7.0	32.0	187/253	35.1	47.6	45
G090HHF,HLF	2.0	460/60/3	5.7	44.0	3.5	14.9	414/506	16.3	22.0	20
K090HHF,HLF	2.0	575/60/3	4.8	34.0	2.5	12.1	515/632	13.3	18.1	15
F110HHF,HLF	1.5	208-230/60/3	13.5	99.0	5.6	32.6	187/253	36.0	49.5	45
G110HHF,HLF	1.5	460/60/3	7.4	49.5	2.8	17.6	414/506	19.5	26.9	25
K110HHF,HLF	1.5	575/60/3	5.7	40.0	1.9	13.3	515/632	14.7	20.4	20
F110HHF,HLF	3.0	208-230/60/3	13.5	99.0	9.0	36.0	187/253	39.4	52.9	50
G110HHF,HLF	3.0	460/60/3	7.4	49.5	4.3	19.1	414/506	21.0	28.4	25
K110HHF,HLF	3.0	575/60/3	5.7	40.0	3.6	15.0	515/632	16.4	22.1	20
F130HHF,HLF	2.0	208-230/60/3	17.3	123.0	7.0	41.6	187/253	45.9	63.2	60
G130HHF,HLF	2.0	460/60/3	9.0	62.0	3.5	21.5	414/506	23.8	32.8	30
K130HHF,HLF	2.0	575/60/3	7.1	50.0	2.5	16.7	515/632	18.5	25.6	25
F130HHF,HLF	3.0	208-230/60/3	17.3	123.0	9.0	43.6	187/253	47.9	65.2	60
G130HHF,HLF	3.0	460/60/3	9.0	62.0	4.3	22.3	414/506	24.6	33.6	30
K130HHF,HLF	3.0	575/60/3	7.1	50.0	3.6	17.8	515/632	19.6	26.7	25

208-230 volt units are shipped for 208 volt operation. For 230 volt operation, change the red tap on the transformer to the orange tap.

NOTE: Fuse protection must be dual element, time delay (Class RK5) type or HACR circuit breaker.

Hangar Bracket Detail

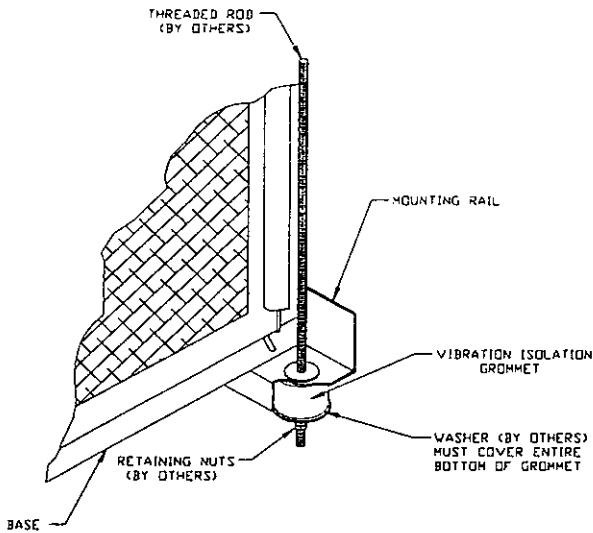

All dimensions are inches (millimeters).

1" and 2" Thick Filter Rack/ Return Air Duct Collar

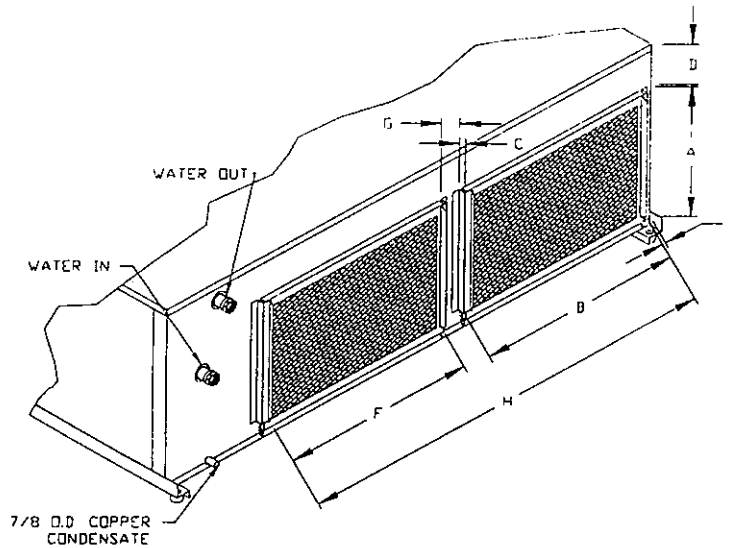

SIZE UNIT	A	B	C	D	E	F	G	H
070-130	18.00 (457)	29.75 (756)	1.00 (25)	6.00 (152)	1.00 (25)	28.00 (711)	3.75 (95)	61.50 (1562)

Dimensional Data

GCH Unit, Left and Right Hand, End and Straight Discharge – 007-036

Cabinet Dimensions, Pipe Connections, Condensate Drain, Electrical Locations

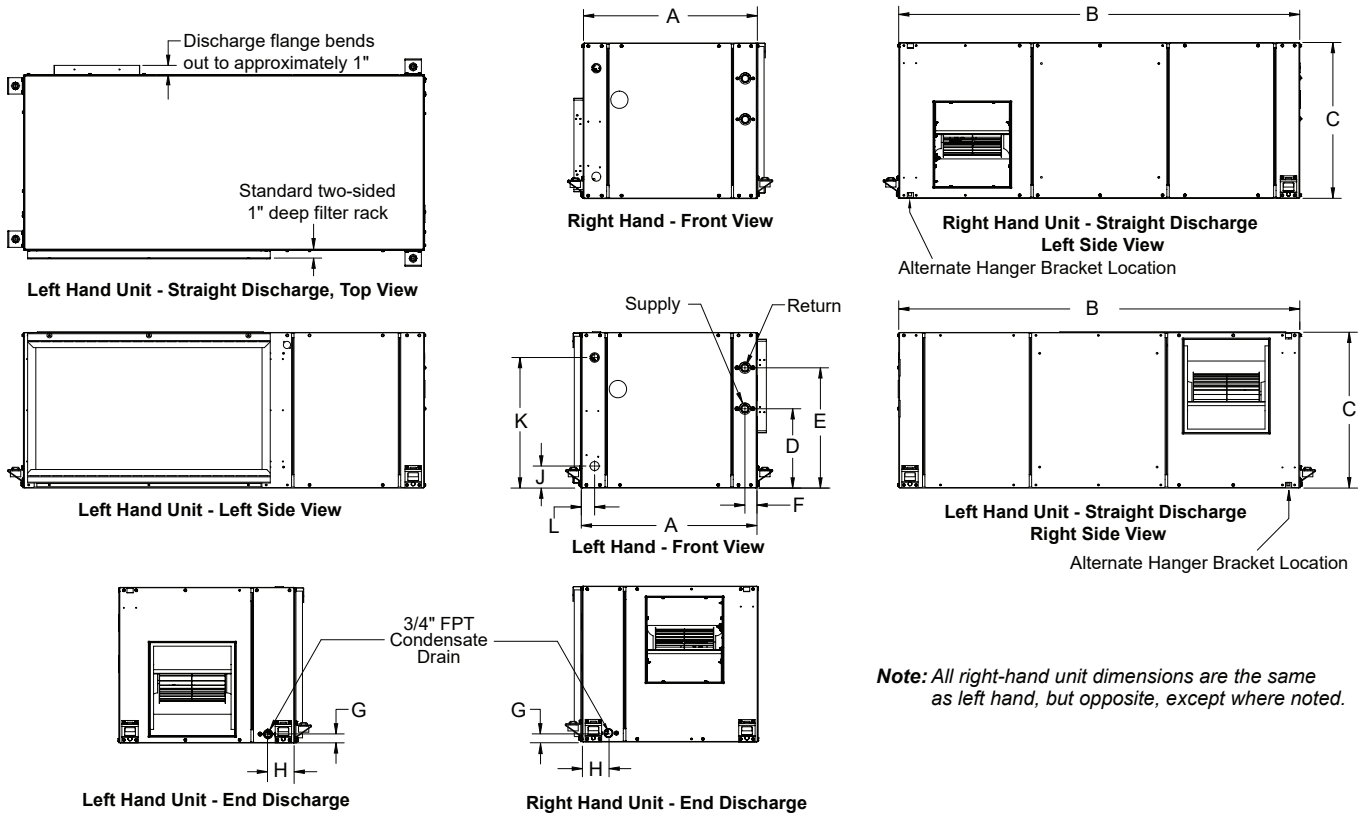

Table 21: GCH unit, left and right hand, end and straight discharge - 007-036

Unit Size	Overall Cabinet Dimensions (in inches)			Pipe Connections (in inches)					3/4" FPT Condensate Drain		Electrical Entry Locations		
				Connection Size (FPT)	D	E	F						
	A = Width	B = Depth	C = Height				Supply	Return	G	H	J (Line Voltage)	K (Low Voltage)	L
007, 009	18.9	33.9	11.5	0.5	1.6	10.3	2.4	1.3	0.9	3.3	2.7	10.4	1.6
012	18.9	33.9	11.5	0.5	1.2	9.7	1.2	1.4	0.9	3.3	2.7	10.4	1.6
015, 019	18.9	41.9	17.0	0.5	7.9	11.4	1.5	1.5	1.4	3.3	2.7	15.7	1.6
024, 030	19.9	42.9	17.3	0.75	7.1	11.2	1.5	1.5	1.4	3.3	2.7	15.9	1.6
036	21.4	48.9	19.0	0.75	9.7	14.6	1.5	1.5	1.4	3.3	2.7	15.9	1.6

GCH Unit, Left and Right Hand, End and Straight Discharge - 042-070

Cabinet Dimensions, Pipe Connections, Condensate Drain, Electrical Locations

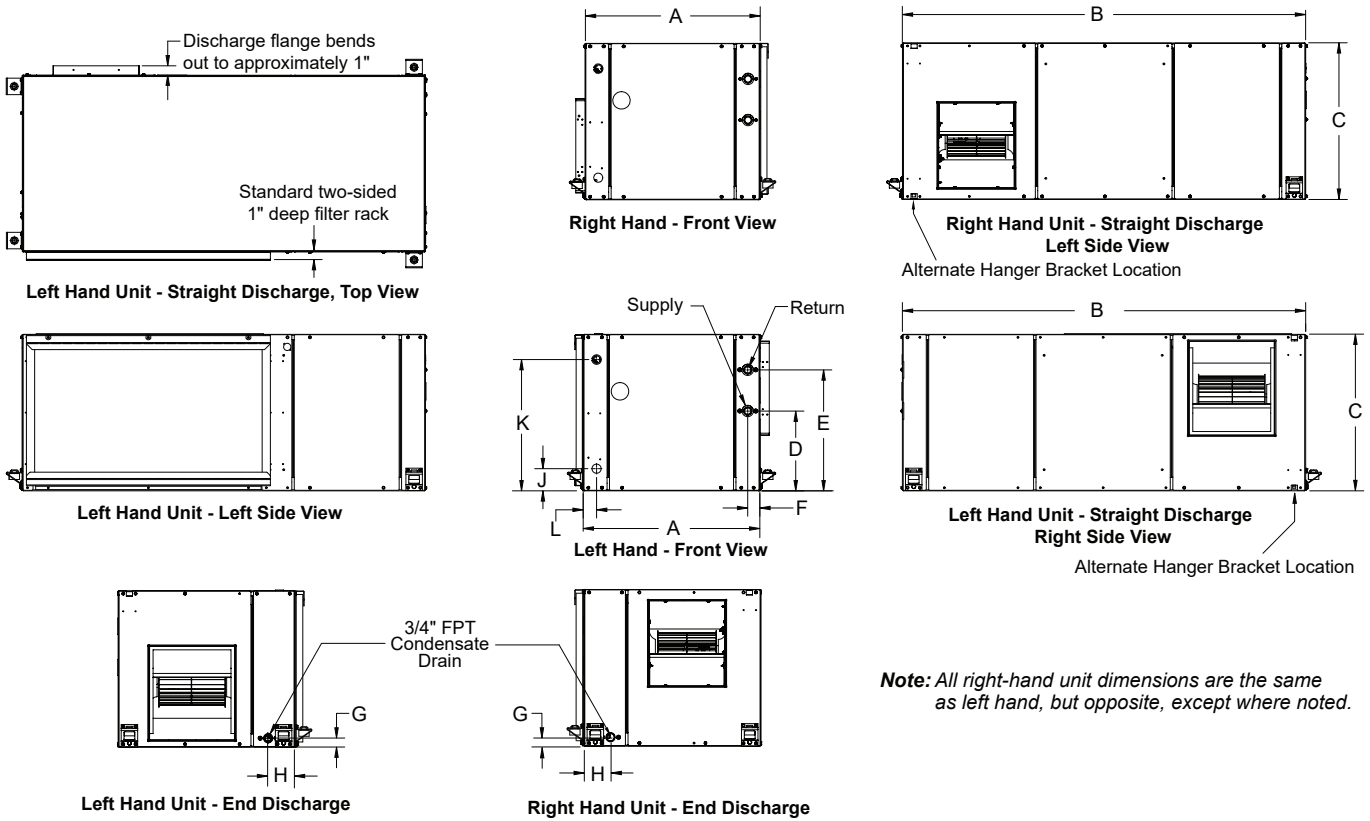

Table 22: GCH unit, left and right hand, end and straight discharge - 042-070

Unit Size	Overall Cabinet Dimensions (in inches)			Pipe Connections (in inches)					3/4" FPT Condensate Drain		Electrical Entry Locations		
				Connection Size (FPT)	D	E	F						
	A = Width	B = Depth	C = Height				Supply	Return	G	H	J (Line Voltage)	K (Low Voltage)	L
042	21.4	48.9	19.0	0.75	9.7	14.6	1.5	1.5	1.1	3.3	2.7	15.9	1.6
048	23.9	53.9	21.0	1.0	10.8	14.6	1.5	1.5	1.4	3.3	2.7	17.7	1.6
060	23.9	53.9	21.0	1.0	10.8	14.6	1.5	1.5	1.4	3.3	2.7	17.7	1.6
070	23.9	64.9	21.0	1.0	10.8	16.1	1.5	1.5	1.4	3.3	2.7	17.7	1.6

GCH Unit, Left and Right Hand, End and Straight Discharge - 007-036

Discharge Opening, Filter Rack Dimensions, Hanger Brackets Locations

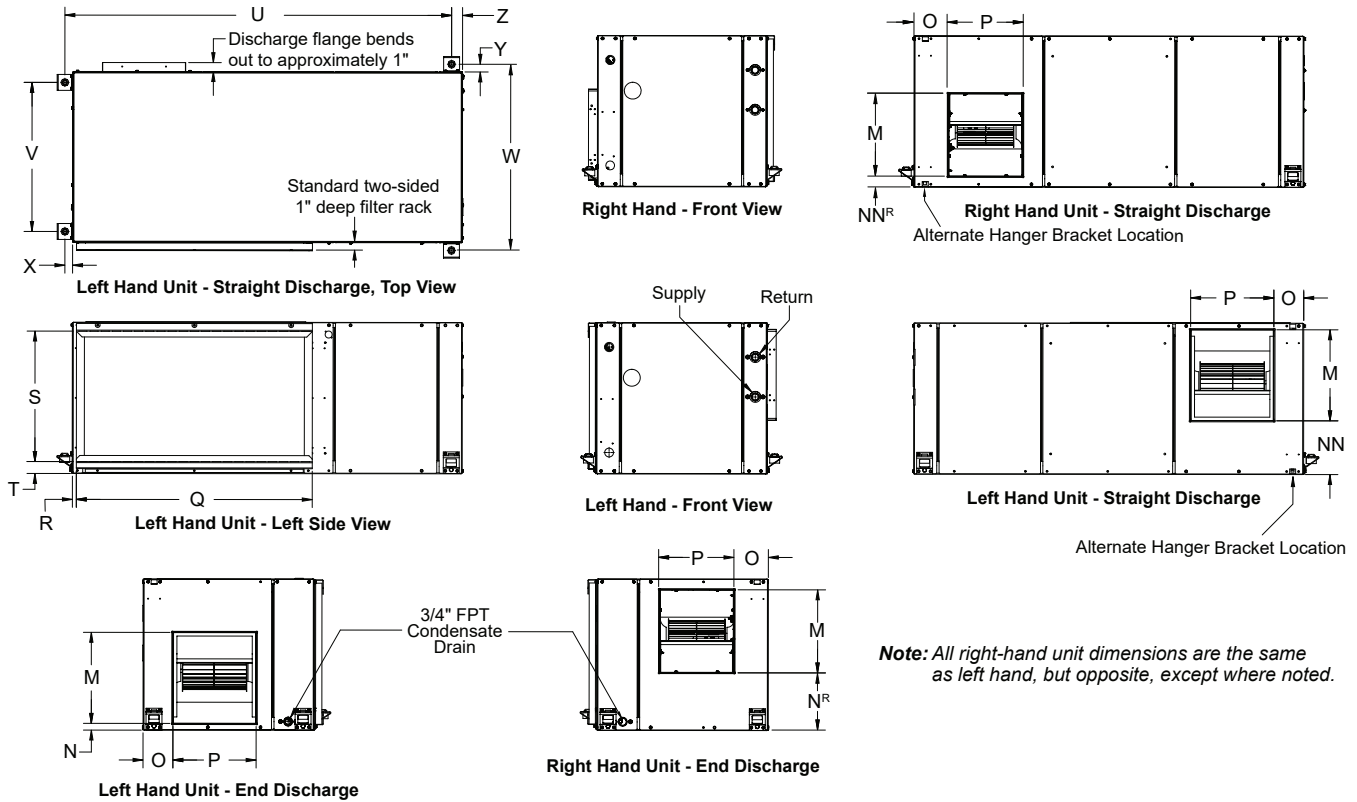

Table 23: GCH unit, left and right hand, end and straight discharge - 007-036

Unit Size	*Discharge Opening (in inches)							Standard Filter Rails Location (in inches)				Hanger Bracket Locations					
	M	N	N ^R	NN	NN ^R	O	P	Q	R	S	T	U	V	W	X	Y	Z
007, 009, 012	4.9	1.3	5.3	5.3	1.3	3.0	9.4	18.4	0.5	10.3	1.0	33.6	16.8	20.9	1.0	1.0	1.1
015, 019	10.4	1.1	5.7	5.7	1.1	3.0	9.3	24.9	0.5	16.3	1.6	41.6	16.2	20.9	1.0	1.0	1.4
024, 030	10.4	1.2	5.8	5.8	1.2	3.4	9.3	23.9	0.5	16.3	1.0	42.6	17.2	21.9	1.0	1.0	1.4
036	10.4	1.4	7.3	7.3	1.4	4.4	9.3	29.6	0.5	18.3	0.6	48.6	18.7	23.4	1.0	1.0	1.4

* Discharge opening dimensions are to the outside edge of flanges bent out to 90 degrees at perforations. Dimensions are approximate and dependent on degree of bend.

GCH Unit, Left and Right Hand, End and Straight Discharge - 042-070

Discharge Opening, Filter Rack Dimensions, Hanger Brackets Locations

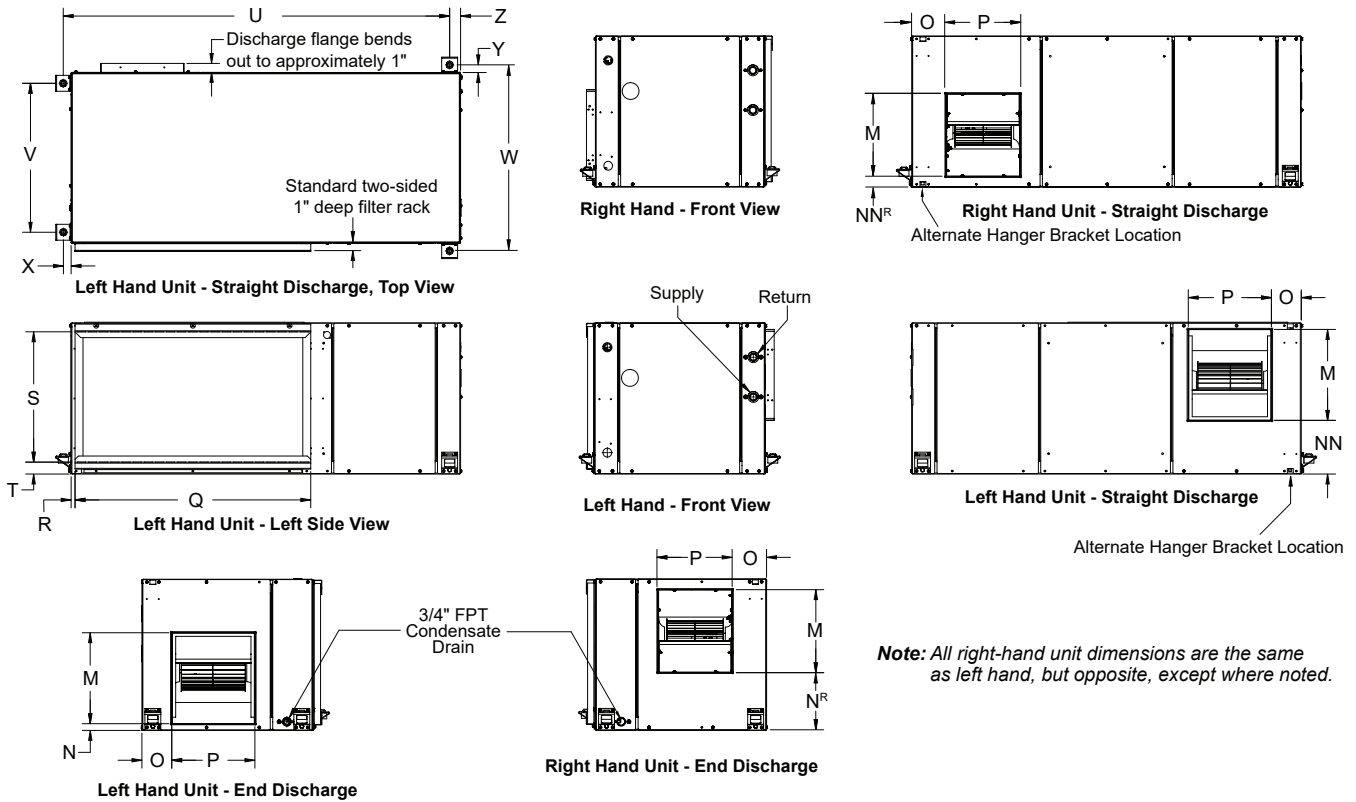

Table 24: GCH unit, left and right hand, end and straight discharge - 042-070

Unit Size	*Discharge Opening (in inches)							Standard Filter Rails Location (in inches)				Hanger Bracket Locations					
	M	N	N ^R	NN	NN ^R	O	P	Q	R	S	T	U	V	W	X	Y	Z
042	11.4	0.8	6.7	6.7	0.8	3.8	10.4	29.6	0.5	18.3	0.6	48.6	18.7	23.4	1.0	1.0	1.4
048	11.4	3.0	6.7	6.7	3.0	5.3	10.4	32.2	1.3	20.3	0.6	53.6	21.2	25.9	1.0	1.0	1.4
060	13.6	2.4	5.0	5.0	2.4	4.5	13.1	32.2	1.3	20.3	0.6	53.6	21.2	25.9	1.0	1.0	1.4
070	13.6	2.4	5.0	5.0	2.4	6.4	13.1	44.3	0.5	20.3	0.6	64.6	21.2	25.9	1.0	1.0	1.4

* Discharge opening dimensions are to the outside edge of flanges bent out to 90 degrees at perforations. Dimensions are approximate and dependent on degree of bend.

CCH/CCW large horizontal – 120

Figure 25: Large horizontal – size 120

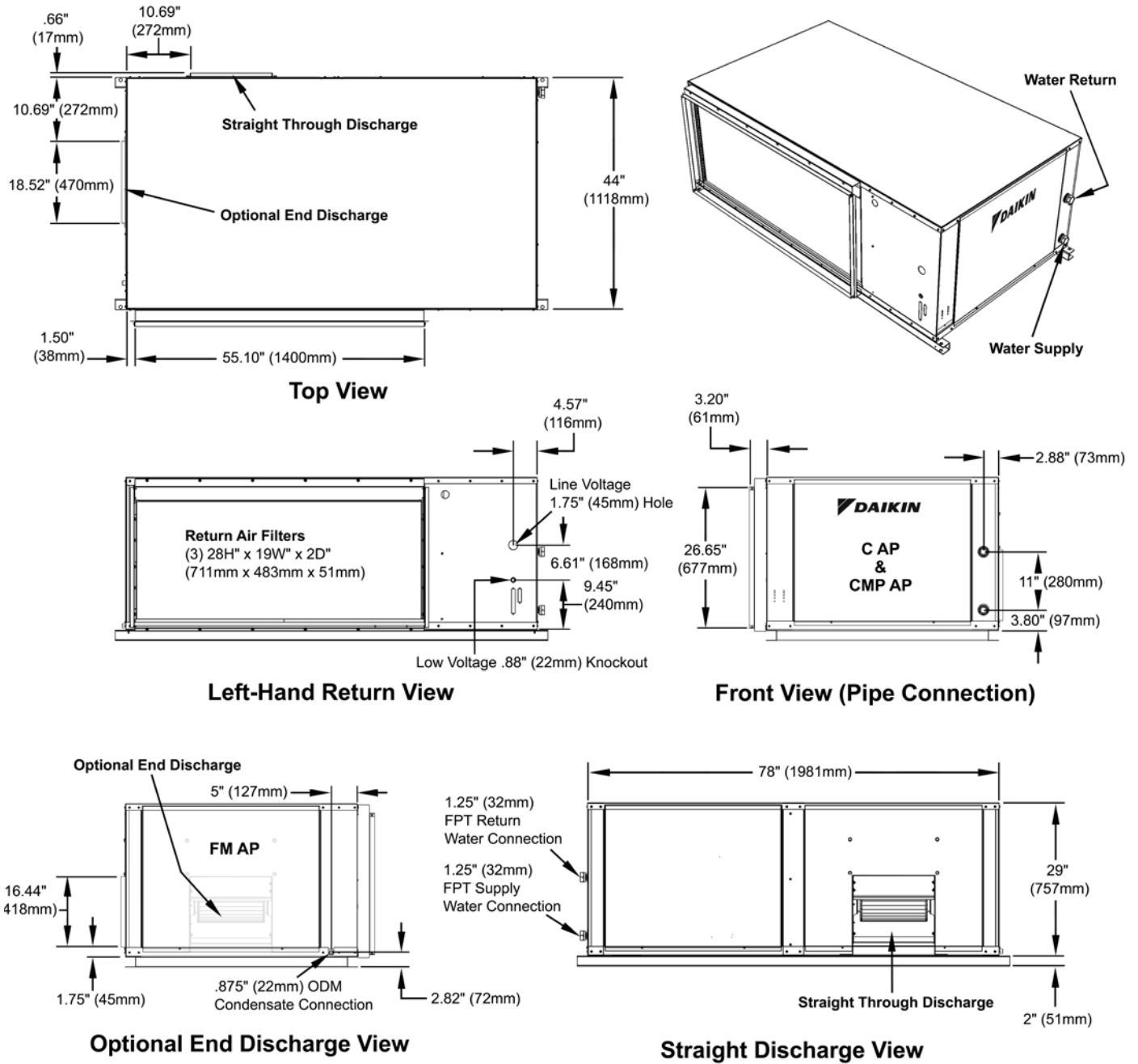

C AP = Control Access Panel CMP AP = Compressor Access Panel FM AP = Fan Motor Access Panel

Overall unit dimensions: 78"L x 44"W x 29"H (add 2" for hanger bracket)

12. Next Regular Board Meeting

13. Adjournment