

STERLING PUBLIC SCHOOL DISTRICT #33, JOHNSON COUNTY

Board of Education Regular Meeting
Monday, November 16, 2020 7:00 PM
Sterling Public Schools
250 Main Street
Sterling, NE 68443

- A. Call Meeting to Order
- B. Recognize Nebraska Open Meetings Law
- C. Publication of Meeting
- D. Roll Call
- E. Pledge of Allegiance
- F. Approval of agenda
- G. Public Comment
- H. Teacher Report
- I. Board Committee Reports
- J. Administration Reports
- K. Consent Agenda
- L. Action Items
 - L.1. Commendations
 - L.2. Consider bid for heat pump replacement in science lab
 - L.3. Consider and approve Sterling Board of Education policy 3004.1
 - L.4. Consider and approve water treatment provider
- M. Discussion Items:
 - M.1. New Nebraska DHMs
 - M.2. Preliminary Budget Audit
- N. Closed Session
- O. Adjourn

The Sterling Board of Education reserves the right to go into Closed Session at any time for purposes in accordance with § 84-1410(1).

Superintendent Report

November 16, 2020

- I. Connectivity Committee
- II. Superintendent Meetings - ESU
 - A. Risk Dials
 - B. 1142 cases statewide (last 30 days), 281 cases
 - C. Nebraska in the top 5
 - D. May change Contract Tracing to prioritize groups
 - E. Taking time to get results
 - F. School will be required to do contact tracing
 - G. Decisions to close are from the Commissioner and/or School Administrators
- III. Village Board Meeting - November 10
 - A. They will help with the practice field
- IV. New Bus arrived
 - A. Three chips in the window
 - B. Will get it in to fix
- V. Community Building
 - A. Won't have the floor until February

Principal Report
November 16, 2020

- A. Formal Evaluations
 - a. 7 probationary teachers completed
 - b. 0 tentured teachers completed
- B. PLC
 - a. New structure to professional development
 - b. Focussed on collaboration with results in mind
- C. Substitute teacher shortage
 - a. 4 substitute teachers on our call list
 - b. 2 in the process of acquiring certificates
 - c. Poses challenges in staffing during pandemic and cold/ flu season
- D. End of 1st Trimester for 6th/ 8th grade classes
 - a. Transition between shop/ ag/ business
- E. Veteran's Day Program
 - a. Smaller turnout
 - b. Great participation

Sterling Public Schools

Account Summary Report

Cycle: FY20/21; Begin Date: 09/01/2020; End Date: 11/30/2020; Account Type: Expenditure,Revenue; Subtotal Elements: [None]; Account Expression: [All]; Subtotal By Account Type: No; Inc No; Created On: 11/12/2020 12:31:28 PM

Account Code	Description	Actual (Date Range)	Budget (YTD)	Actual (YTD)	Encumbrance (YTD)	Available (YTD)
01-1-01100-000-000	Taxes Levied/Assessed by the School District	(\$892,687.21)	\$0.00	(\$892,687.21)	\$0.00	\$892,687.21
01-1-01115-000-000	CARLINE TAXES	(\$1,170.58)	\$0.00	(\$1,170.58)	\$0.00	\$1,170.58
01-1-01125-000-000	MOTOR VEHICLE TAXES	(\$18,282.50)	\$0.00	(\$18,282.50)	\$0.00	\$18,282.50
01-1-01140-000-000	Penalties and Interest on Taxes	(\$1,370.12)	\$0.00	(\$1,370.12)	\$0.00	\$1,370.12
01-1-01510-000-000	INTEREST	(\$77.14)	\$0.00	(\$77.14)	\$0.00	\$77.14
01-1-01900-000-000		(\$75.00)	\$0.00	(\$75.00)	\$0.00	\$75.00
01-1-01920-000-000	CONTRIBUTIONS AND DONATIONS	(\$200.00)	\$0.00	(\$200.00)	\$0.00	\$200.00
01-1-01980-000-000	Refund of Prior Year?s Expenditures	(\$1,055.00)	\$0.00	(\$1,055.00)	\$0.00	\$1,055.00
01-1-01990-000-000	OTHER LOCAL RECEIPTS	(\$1,125.26)	\$0.00	(\$1,125.26)	\$0.00	\$1,125.26
01-1-02110-000-000	COUNTY FINES AND LICENSE FEES	(\$1,675.48)	\$0.00	(\$1,675.48)	\$0.00	\$1,675.48
01-1-02130-000-000	OTHER COUNTY RECEIPTS	(\$138.77)	\$0.00	(\$138.77)	\$0.00	\$138.77
01-1-03110-000-000	STATE AID	(\$4,668.00)	\$0.00	(\$4,668.00)	\$0.00	\$4,668.00
01-1-03180-000-000	PRO-RATE MOTOR VEHICLE	(\$663.30)	\$0.00	(\$663.30)	\$0.00	\$663.30
01-1-03512-000-000	DISTANCE EDUCATION INCENTIVE PAYMENTS	(\$3,859.64)	\$0.00	(\$3,859.64)	\$0.00	\$3,859.64
01-1-03535-000-000	PAYMENTS FOR HIGH ABILITY LEARNERS	(\$3,275.00)	\$0.00	(\$3,275.00)	\$0.00	\$3,275.00
01-2-01100-105-000	REGULAR INSTRUCTIONAL PROGRAMS	\$55.50	\$0.00	\$55.50	\$0.00	(\$55.50)
01-2-01100-111-001	REGULAR INSTRUCTIONAL PROGRAMS	\$123,725.61	\$0.00	\$123,725.61	\$0.00	(\$123,725.61)
01-2-01100-111-002	REGULAR INSTRUCTIONAL PROGRAMS	\$94,205.64	\$0.00	\$94,205.64	\$0.00	(\$94,205.64)
01-2-01100-112-001	REGULAR INSTRUCTIONAL PROGRAMS	\$1,847.56	\$0.00	\$1,847.56	\$0.00	(\$1,847.56)
01-2-01100-112-002	REGULAR INSTRUCTIONAL PROGRAMS	\$4,878.31	\$0.00	\$4,878.31	\$0.00	(\$4,878.31)
01-2-01100-113-001	REGULAR INSTRUCTIONAL PROGRAMS	\$2,534.49	\$0.00	\$2,534.49	\$0.00	(\$2,534.49)
01-2-01100-113-002	REGULAR INSTRUCTIONAL PROGRAMS	\$2,534.49	\$0.00	\$2,534.49	\$0.00	(\$2,534.49)
01-2-01100-123-001	REGULAR INSTRUCTIONAL PROGRAMS	\$1,470.00	\$0.00	\$1,470.00	\$0.00	(\$1,470.00)
01-2-01100-123-002	REGULAR INSTRUCTIONAL PROGRAMS	\$1,830.00	\$0.00	\$1,830.00	\$0.00	(\$1,830.00)
01-2-01100-151-001	REGULAR INSTRUCTIONAL PROGRAMS	\$15,808.33	\$0.00	\$15,808.33	\$0.00	(\$15,808.33)
01-2-01100-151-002	REGULAR INSTRUCTIONAL PROGRAMS	\$37.50	\$0.00	\$37.50	\$0.00	(\$37.50)
01-2-01100-156-001	REGULAR INSTRUCTIONAL PROGRAMS	\$3,347.37	\$0.00	\$3,347.37	\$0.00	(\$3,347.37)
01-2-01100-211-001	REGULAR INSTRUCTIONAL PROGRAMS	\$37,102.20	\$0.00	\$37,102.20	\$0.00	(\$37,102.20)
01-2-01100-211-002	REGULAR INSTRUCTIONAL PROGRAMS	\$16,564.68	\$0.00	\$16,564.68	\$0.00	(\$16,564.68)
01-2-01100-221-001	REGULAR INSTRUCTIONAL PROGRAMS	\$12,901.08	\$0.00	\$12,901.08	\$0.00	(\$12,901.08)
01-2-01100-221-002	REGULAR INSTRUCTIONAL PROGRAMS	\$7,837.22	\$0.00	\$7,837.22	\$0.00	(\$7,837.22)
01-2-01100-222-001	REGULAR INSTRUCTIONAL PROGRAMS	\$141.04	\$0.00	\$141.04	\$0.00	(\$141.04)
01-2-01100-222-002	REGULAR INSTRUCTIONAL PROGRAMS	\$371.88	\$0.00	\$371.88	\$0.00	(\$371.88)
01-2-01100-223-001	REGULAR INSTRUCTIONAL PROGRAMS	\$306.26	\$0.00	\$306.26	\$0.00	(\$306.26)
01-2-01100-223-002	REGULAR INSTRUCTIONAL PROGRAMS	\$333.82	\$0.00	\$333.82	\$0.00	(\$333.82)
01-2-01100-225-000	REGULAR INSTRUCTIONAL PROGRAMS	\$4.26	\$0.00	\$4.26	\$0.00	(\$4.26)
01-2-01100-226-001	REGULAR INSTRUCTIONAL PROGRAMS	\$256.08	\$0.00	\$256.08	\$0.00	(\$256.08)

01-2-01100-231-001	REGULAR INSTRUCTIONAL PROGRAMS	\$36,479.79	\$0.00	\$36,479.79	\$0.00	(\$36,479.79)
01-2-01100-231-002	REGULAR INSTRUCTIONAL PROGRAMS	\$19,308.43	\$0.00	\$19,308.43	\$0.00	(\$19,308.43)
01-2-01100-232-002	REGULAR INSTRUCTIONAL PROGRAMS	\$450.97	\$0.00	\$450.97	\$0.00	(\$450.97)
01-2-01100-233-001	REGULAR INSTRUCTIONAL PROGRAMS	\$83.45	\$0.00	\$83.45	\$0.00	(\$83.45)
01-2-01100-233-002	REGULAR INSTRUCTIONAL PROGRAMS	\$83.45	\$0.00	\$83.45	\$0.00	(\$83.45)
01-2-01100-281-001	REGULAR INSTRUCTIONAL PROGRAMS	\$9,000.00	\$0.00	\$9,000.00	\$0.00	(\$9,000.00)
01-2-01100-340-001	Regular Instruction-Other Professional Services-Sec	\$0.00	\$0.00	\$0.00	\$252.00	(\$252.00)
01-2-01100-382-000	REGULAR INSTRUCTIONAL PROGRAMS	\$464.98	\$0.00	\$464.98	\$0.00	(\$464.98)
01-2-01100-580-001	REGULAR INSTRUCTIONAL PROGRAMS	\$15.00	\$0.00	\$15.00	\$0.00	(\$15.00)
01-2-01100-610-000	REGULAR INSTRUCTIONAL PROGRAMS	\$4,341.61	\$0.00	\$4,341.61	\$172.95	(\$4,514.56)
01-2-01100-610-001	REGULAR INSTRUCTIONAL PROGRAMS	\$1,692.79	\$0.00	\$1,692.79	\$0.00	(\$1,692.79)
01-2-01100-610-002	REGULAR INSTRUCTIONAL PROGRAMS	\$225.17	\$0.00	\$225.17	\$0.00	(\$225.17)
01-2-01100-640-000	REGULAR INSTRUCTIONAL PROGRAMS	\$24.34	\$0.00	\$24.34	\$0.00	(\$24.34)
01-2-01100-640-001	REGULAR INSTRUCTIONAL PROGRAMS	\$657.24	\$0.00	\$657.24	\$0.00	(\$657.24)
01-2-01100-640-002	REGULAR INSTRUCTIONAL PROGRAMS	\$369.36	\$0.00	\$369.36	\$886.23	(\$1,255.59)
01-2-01100-643-001	REGULAR INSTRUCTIONAL PROGRAMS	\$2,800.00	\$0.00	\$2,800.00	\$0.00	(\$2,800.00)
01-2-01100-650-000	REGULAR INSTRUCTIONAL PROGRAMS	\$367.00	\$0.00	\$367.00	\$591.22	(\$958.22)
01-2-01100-650-001	REGULAR INSTRUCTIONAL PROGRAMS	\$1,201.31	\$0.00	\$1,201.31	\$0.00	(\$1,201.31)
01-2-01100-650-002	REGULAR INSTRUCTIONAL PROGRAMS	\$737.89	\$0.00	\$737.89	\$0.00	(\$737.89)
01-2-01100-734-001	Regular Instruction-Technology-Related Hardware-Sec	\$312.17	\$0.00	\$312.17	\$0.00	(\$312.17)
01-2-01100-734-002	Regular Instruction-Technology-Related Hardware-Elem	\$9,249.07	\$0.00	\$9,249.07	\$0.00	(\$9,249.07)
01-2-01100-735-000	Regular Instruction-Technology Software	\$0.00	\$0.00	\$0.00	\$1,160.00	(\$1,160.00)
01-2-01100-810-000	Regular Instruction-Dues and Fees	\$40.00	\$0.00	\$40.00	\$0.00	(\$40.00)
01-2-01100-810-001	Regular Instruction-Dues and Fees-Sec	\$76.36	\$0.00	\$76.36	\$0.00	(\$76.36)
01-2-01100-810-002	Regular Instruction-Dues and Fees-Elem	\$76.36	\$0.00	\$76.36	\$0.00	(\$76.36)
01-2-01190-111-002	Early Childhood Educational Programs-Salaries of Regular Employees Paid to Teachers/Professional Staff-Elem	\$23,985.00	\$0.00	\$23,985.00	\$0.00	(\$23,985.00)
01-2-01190-112-002	Early Childhood Educational Programs-Salaries of Regular Employees Paid to Instructional Aides and Assistants-Elem	\$8,656.29	\$0.00	\$8,656.29	\$0.00	(\$8,656.29)
01-2-01190-113-002	Early Childhood Educational Programs-Salaries of Regular Employees Paid to Substitute Teachers-Elem	\$180.00	\$0.00	\$180.00	\$0.00	(\$180.00)
01-2-01190-211-002	Early Childhood Educational Programs-Group Insurance for Teachers/Professional Staff-Elem	\$12,157.19	\$0.00	\$12,157.19	\$0.00	(\$12,157.19)
01-2-01190-221-002	Early Childhood Educational Programs-Social Security Payments for Teachers/Professional Staff-Elem	\$1,683.88	\$0.00	\$1,683.88	\$0.00	(\$1,683.88)
01-2-01190-222-002	Early Childhood Educational Programs-Social Security Payments for Instructional Aides or Assistants-Elem	\$662.21	\$0.00	\$662.21	\$0.00	(\$662.21)
01-2-01190-223-002	Early Childhood Educational Programs-Social Security Payments for Substitute Teachers-Elem	\$13.77	\$0.00	\$13.77	\$0.00	(\$13.77)
01-2-01190-231-002	Early Childhood Educational Programs-Retirement Contributions for Teachers/Professional Staff-Elem	\$2,369.19	\$0.00	\$2,369.19	\$0.00	(\$2,369.19)
01-2-01190-232-002	Early Childhood Educational Programs-Retirement Contributions for Instructional Aides or Assistants-Elem	\$855.05	\$0.00	\$855.05	\$0.00	(\$855.05)
01-2-01190-550-002	Early Childhood Educational Programs-Printing and Binding-Elem	\$39.90	\$0.00	\$39.90	\$0.00	(\$39.90)

01-2-01190-610-000	Early Childhood Educational Programs-General Supplies	\$516.99	\$0.00	\$516.99	\$0.00	(\$516.99)
01-2-01190-610-002	Early Childhood Educational Programs-General Supplies-Flom	\$633.14	\$0.00	\$633.14	\$0.00	(\$633.14)
01-2-01200-111-001	Special Education Instructional Programs - School Age-Salaries of Regular Employees Paid to Teachers/Professional Staff See	\$13,284.00	\$0.00	\$13,284.00	\$0.00	(\$13,284.00)
01-2-01200-111-002	Special Education Instructional Programs - School Age-Salaries of Regular Employees Paid to Teachers/Professional Staff Flom	\$11,439.00	\$0.00	\$11,439.00	\$0.00	(\$11,439.00)
01-2-01200-112-001	Special Education Instructional Programs - School Age-Salaries of Regular Employees Paid to Instructional Aides and Assistants See	\$8,881.59	\$0.00	\$8,881.59	\$0.00	(\$8,881.59)
01-2-01200-112-002	Special Education Instructional Programs - School Age-Salaries of Regular Employees Paid to Instructional Aides and Assistants Flom	\$12,966.28	\$0.00	\$12,966.28	\$0.00	(\$12,966.28)
01-2-01200-211-001	Special Education Instructional Programs - School Age-Group Insurance for Teachers/Professional Staff See	\$6,232.73	\$0.00	\$6,232.73	\$0.00	(\$6,232.73)
01-2-01200-211-002	Special Education Instructional Programs - School Age-Group Insurance for Teachers/Professional Staff Flom	\$2,196.48	\$0.00	\$2,196.48	\$0.00	(\$2,196.48)
01-2-01200-212-000	Special Education Instructional Programs - School Age-Group Insurance for Instructional Aides or Assistants	\$14.54	\$0.00	\$14.54	\$0.00	(\$14.54)
01-2-01200-221-001	Special Education Instructional Programs - School Age-Social Security Payments for Teachers/Professional Staff See	\$896.16	\$0.00	\$896.16	\$0.00	(\$896.16)
01-2-01200-221-002	Special Education Instructional Programs - School Age-Social Security Payments for Teachers/Professional Staff Flom	\$1,644.33	\$0.00	\$1,644.33	\$0.00	(\$1,644.33)
01-2-01200-222-000	Special Education Instructional Programs - School Age-Social Security Payments for Instructional Aides or Assistants	\$1.12	\$0.00	\$1.12	\$0.00	(\$1.12)
01-2-01200-222-001	Special Education Instructional Programs - School Age-Social Security Payments for Instructional Aides or Assistants See	\$673.70	\$0.00	\$673.70	\$0.00	(\$673.70)
01-2-01200-222-002	Special Education Instructional Programs - School Age-Social Security Payments for Instructional Aides or Assistants Flom	\$954.14	\$0.00	\$954.14	\$0.00	(\$954.14)
01-2-01200-231-001	Special Education Instructional Programs - School Age-Retirement Contributions for Teachers/Professional Staff See	\$1,312.17	\$0.00	\$1,312.17	\$0.00	(\$1,312.17)
01-2-01200-231-002	Special Education Instructional Programs - School Age-Retirement Contributions for Teachers/Professional Staff Flom	\$11,129.95	\$0.00	\$11,129.95	\$0.00	(\$11,129.95)
01-2-01200-232-001	Special Education Instructional Programs - School Age-Retirement Contributions for Instructional Aides or Assistants See	\$829.50	\$0.00	\$829.50	\$0.00	(\$829.50)
01-2-01200-232-002	Special Education Instructional Programs - School Age-Retirement Contributions for Instructional Aides or Assistants Flom	\$1,232.97	\$0.00	\$1,232.97	\$0.00	(\$1,232.97)
01-2-01200-382-000	SPECIAL EDUCATION INSTRUCTIONAL PROGRAMS	\$75.00	\$0.00	\$75.00	\$0.00	(\$75.00)
01-2-01200-591-001	Special Education Instructional Programs - School Age-Services Purchased From Another School District or Educational Services Agency Within the State See	\$2,666.00	\$0.00	\$2,666.00	\$0.00	(\$2,666.00)
01-2-01200-591-002	Special Education Instructional Programs - School Age-Services Purchased From Another School District or Educational Services Agency Within the State Flom	\$2,666.00	\$0.00	\$2,666.00	\$0.00	(\$2,666.00)

01-2-01300-111-001	Summer School-Salaries of Regular Employees Paid to Teachers/Professional Staff-Sec	\$48.26	\$0.00	\$48.26	\$0.00	(\$48.26)
01-2-01300-221-001	Summer School-Social Security Payments for Teachers/Professional Staff-Sec	\$3.66	\$0.00	\$3.66	\$0.00	(\$3.66)
01-2-02120-111-001	Guidance Services-Salaries of Regular Employees Paid to Teachers/Professional Staff-Sec	\$7,933.50	\$0.00	\$7,933.50	\$0.00	(\$7,933.50)
01-2-02120-111-002	Guidance Services-Salaries of Regular Employees Paid to Teachers/Professional Staff-Flem	\$7,933.50	\$0.00	\$7,933.50	\$0.00	(\$7,933.50)
01-2-02120-151-001	Guidance Services-Additional Compensation Paid to Teachers/Professional Staff-Sec	\$428.82	\$0.00	\$428.82	\$0.00	(\$428.82)
01-2-02120-151-002	Guidance Services-Additional Compensation Paid to Teachers/Professional Staff-Flem	\$428.85	\$0.00	\$428.85	\$0.00	(\$428.85)
01-2-02120-211-001	Guidance Services-Group Insurance for Teachers/Professional Staff-Sec	\$3,116.35	\$0.00	\$3,116.35	\$0.00	(\$3,116.35)
01-2-02120-211-002	Guidance Services-Group Insurance for Teachers/Professional Staff-Flem	\$3,116.38	\$0.00	\$3,116.38	\$0.00	(\$3,116.38)
01-2-02120-221-001	Guidance Services-Social Security Payments for Teachers/Professional Staff-Sec	\$612.54	\$0.00	\$612.54	\$0.00	(\$612.54)
01-2-02120-221-002	Guidance Services-Social Security Payments for Teachers/Professional Staff-Flem	\$612.57	\$0.00	\$612.57	\$0.00	(\$612.57)
01-2-02120-231-001	Guidance Services-Retirement Contributions for Teachers/Professional Staff-Sec	\$826.02	\$0.00	\$826.02	\$0.00	(\$826.02)
01-2-02120-231-002	Guidance Services-Retirement Contributions for Teachers/Professional Staff-Flem	\$826.02	\$0.00	\$826.02	\$0.00	(\$826.02)
01-2-02120-565-001	Guidance Services-Tuition to Postsecondary Schools-Sec	\$2,685.00	\$0.00	\$2,685.00	\$0.00	(\$2,685.00)
01-2-02120-610-001	Guidance Services-General Supplies-Sec	\$36.47	\$0.00	\$36.47	\$0.00	(\$36.47)
01-2-02140-320-001	Psychological Services-Professional Educational Services-Sec	\$986.00	\$0.00	\$986.00	\$0.00	(\$986.00)
01-2-02141-334-000	Psychological Services - SPED - School Age-	\$449.00	\$0.00	\$449.00	\$0.00	(\$449.00)
01-2-02141-334-002	Psychological Services - SPED - School Age--Elem	\$44.22	\$0.00	\$44.22	\$0.00	(\$44.22)
01-2-02141-591-001	Psychological Services - SPED - School Age-Services Purchased From Another School District or Educational Services Agency Within the State-	\$4,666.50	\$0.00	\$4,666.50	\$0.00	(\$4,666.50)
01-2-02141-591-002	Psychological Services - SPED - School Age-Services Purchased From Another School District or Educational Services Agency Within the State-	\$4,666.50	\$0.00	\$4,666.50	\$0.00	(\$4,666.50)
01-2-02151-591-001	Speech Pathology and Audiology Services - SPED - School Age-Services Purchased From Another School District or Educational Services Agency Within the State-	\$1,453.50	\$0.00	\$1,453.50	\$0.00	(\$1,453.50)
01-2-02151-591-002	Speech Pathology and Audiology Services - SPED - School Age-Services Purchased From Another School District or Educational Services Agency Within the State-	\$10,579.50	\$0.00	\$10,579.50	\$0.00	(\$10,579.50)
01-2-02161-591-001	Occupational Therapy-Related Services - SPED - School Age-Services Purchased From Another School District or Educational Services Agency Within the State-	\$156.11	\$0.00	\$156.11	\$0.00	(\$156.11)
01-2-02161-591-002	Occupational Therapy-Related Services - SPED - School Age-Services Purchased From Another School District or Educational Services Agency Within the State-	\$2,649.18	\$0.00	\$2,649.18	\$0.00	(\$2,649.18)
01-2-02162-591-002	Occupational Therapy-Related Services - SPED - Ages 3-5-Services Purchased From Another School District or Educational Services Agency Within the State-	\$112.56	\$0.00	\$112.56	\$0.00	(\$112.56)

01-2-02171-591-002	Physical Therapy-Related Services - SPED - School Age-Services Purchased From Another School District or Educational Services Agency Within the State Elem	\$155.44	\$0.00	\$155.44	\$0.00	(\$155.44)
01-2-02181-591-002	Visually Impaired or Vision Services - SPED - School Age-Services Purchased From Another School District or Educational Services Agency Within the State Elem	\$583.70	\$0.00	\$583.70	\$0.00	(\$583.70)
01-2-02190-110-000	OTHER PUPIL SUPPORT SERVICES	\$510.50	\$0.00	\$510.50	\$0.00	(\$510.50)
01-2-02190-220-000	OTHER PUPIL SUPPORT SERVICES	\$39.05	\$0.00	\$39.05	\$0.00	(\$39.05)
01-2-02190-230-000	Support Services - Student - Other-Retirement Contributions for Non-Instructional	\$50.42	\$0.00	\$50.42	\$0.00	(\$50.42)
01-2-02213-330-001	Instructional Staff Training-Employee Training and Development Services-Sec	\$250.00	\$0.00	\$250.00	\$0.00	(\$250.00)
01-2-02220-111-002	Library or Media Services-Salaries of Regular Employees Paid to Teachers/Professional Staff-Elem	\$9,815.49	\$0.00	\$9,815.49	\$0.00	(\$9,815.49)
01-2-02220-211-002	SCHOOL LIBRARY SERVICES	\$39.00	\$0.00	\$39.00	\$0.00	(\$39.00)
01-2-02220-221-002	Library or Media Services-Social Security Payments for Teachers/Professional Staff-Elem	\$753.87	\$0.00	\$753.87	\$0.00	(\$753.87)
01-2-02220-231-002	SCHOOL LIBRARY SERVICES	\$969.57	\$0.00	\$969.57	\$0.00	(\$969.57)
01-2-02220-610-001	Library or Media Services-General Supplies-Sec	\$14.99	\$0.00	\$14.99	\$0.00	(\$14.99)
01-2-02220-640-001	Library or Media Services-Books and Periodical-Sec	\$209.12	\$0.00	\$209.12	\$0.00	(\$209.12)
01-2-02220-640-002	Library or Media Services-Books and Periodical-Elem	\$112.59	\$0.00	\$112.59	\$0.00	(\$112.59)
01-2-02230-530-000	Instruction-Related Technology-Communications	\$1,662.00	\$0.00	\$1,662.00	\$0.00	(\$1,662.00)
01-2-02230-591-000	Instruction-Related Technology-Services Purchased From Another School District or Educational Services Agency Within the State	\$20,000.00	\$0.00	\$20,000.00	\$0.00	(\$20,000.00)
01-2-02230-643-000	Instruction-Related Technology-Web/Cloud Based Software	\$8,930.05	\$0.00	\$8,930.05	\$0.00	(\$8,930.05)
01-2-02290-310-000	Other Support Services - Instructional Staff-Official/Administrative Services	\$638.03	\$0.00	\$638.03	\$0.00	(\$638.03)
01-2-02310-531-000	Board of Education-Postage	\$115.08	\$0.00	\$115.08	\$0.00	(\$115.08)
01-2-02310-540-000	Board of Education-Advertising	\$782.04	\$0.00	\$782.04	\$0.00	(\$782.04)
01-2-02310-810-000	Board of Education-Dues and Fees	\$380.45	\$0.00	\$380.45	\$0.00	(\$380.45)
01-2-02320-105-000	EXECUTIVE ADMINISTRATION SERVICES	\$28,382.22	\$0.00	\$28,382.22	\$0.00	(\$28,382.22)
01-2-02320-215-000	Executive Administration-Group Insurance for Superintendents	\$6,202.95	\$0.00	\$6,202.95	\$0.00	(\$6,202.95)
01-2-02320-225-000	Executive Administration-Social Security Payments for Superintendents	\$2,140.20	\$0.00	\$2,140.20	\$0.00	(\$2,140.20)
01-2-02320-235-000	Executive Administration-Retirement Contributions for Superintendents	\$1,869.02	\$0.00	\$1,869.02	\$0.00	(\$1,869.02)
01-2-02320-310-000	EXECUTIVE ADMINISTRATION SERVICES	\$95.00	\$0.00	\$95.00	\$0.00	(\$95.00)
01-2-02320-333-001	Executive Administration-Mileage Paid to Staff-Sec	\$12.29	\$0.00	\$12.29	\$0.00	(\$12.29)
01-2-02320-382-000	EXECUTIVE ADMINISTRATION SERVICES	\$150.00	\$0.00	\$150.00	\$0.00	(\$150.00)
01-2-02320-580-000	Executive Administration-Travel	\$13.65	\$0.00	\$13.65	\$0.00	(\$13.65)
01-2-02320-810-000	Executive Administration-Dues and Fees	\$150.00	\$0.00	\$150.00	\$0.00	(\$150.00)
01-2-02330-317-000	District Legal Services-Contracted Legal Services	\$1,149.28	\$0.00	\$1,149.28	\$0.00	(\$1,149.28)
01-2-02410-110-000	OFFICE OF THE PRINCIPAL	\$8,926.12	\$0.00	\$8,926.12	\$0.00	(\$8,926.12)
01-2-02410-111-001	Office of the Principal-Salaries of Regular Employees Paid to Teachers/Professional Staff-Sec	\$9,375.00	\$0.00	\$9,375.00	\$0.00	(\$9,375.00)

01-2-02410-111-002	Office of the Principal-Salaries of Regular Employees Paid to Teachers/Professional Staff- Elem	\$9,375.00	\$0.00	\$9,375.00	\$0.00	(\$9,375.00)
01-2-02410-211-001	Office of the Principal-Group Insurance for Teachers/Professional Staff-Sec	\$2,965.50	\$0.00	\$2,965.50	\$0.00	(\$2,965.50)
01-2-02410-211-002	Office of the Principal-Group Insurance for Teachers/Professional Staff-Elem	\$2,965.53	\$0.00	\$2,965.53	\$0.00	(\$2,965.53)
01-2-02410-220-000	OFFICE OF THE PRINCIPAL	\$682.85	\$0.00	\$682.85	\$0.00	(\$682.85)
01-2-02410-221-001	Office of the Principal-Social Security Payments for Teachers/Professional Staff-Sec	\$701.94	\$0.00	\$701.94	\$0.00	(\$701.94)
01-2-02410-221-002	Office of the Principal-Social Security Payments for Teachers/Professional Staff-Elem	\$701.97	\$0.00	\$701.97	\$0.00	(\$701.97)
01-2-02410-230-000	OFFICE OF THE PRINCIPAL	\$881.71	\$0.00	\$881.71	\$0.00	(\$881.71)
01-2-02410-231-001	Office of the Principal-Retirement Contributions for Teachers/Professional Staff-Sec	\$926.04	\$0.00	\$926.04	\$0.00	(\$926.04)
01-2-02410-231-002	Office of the Principal-Retirement Contributions for Teachers/Professional Staff-Elem	\$926.04	\$0.00	\$926.04	\$0.00	(\$926.04)
01-2-02410-382-000	OFFICE OF THE PRINCIPAL	\$150.00	\$0.00	\$150.00	\$0.00	(\$150.00)
01-2-02510-110-000	SUPPORT SERVICES - BUSINESS	\$10,049.91	\$0.00	\$10,049.91	\$0.00	(\$10,049.91)
01-2-02510-210-000	SUPPORT SERVICES - BUSINESS	\$27.51	\$0.00	\$27.51	\$0.00	(\$27.51)
01-2-02510-220-000	SUPPORT SERVICES - BUSINESS	\$761.04	\$0.00	\$761.04	\$0.00	(\$761.04)
01-2-02510-230-000	SUPPORT SERVICES - BUSINESS	\$992.71	\$0.00	\$992.71	\$0.00	(\$992.71)
01-2-02530-550-000	Printing, Publishing, and Duplicating Services- Printing and Binding	\$4,397.83	\$0.00	\$4,397.83	\$0.00	(\$4,397.83)
01-2-02570-810-000	Personnel Services-Dues and Fees	\$170.00	\$0.00	\$170.00	\$0.00	(\$170.00)
01-2-02580-643-000	Administrative Technology Service-Web/Cloud Based Software	\$209.20	\$0.00	\$209.20	\$3,960.00	(\$4,169.20)
01-2-02580-650-000	Administrative Technology Service-Supplies- Technology Related	\$573.94	\$0.00	\$573.94	\$202.99	(\$776.93)
01-2-02610-110-000	SUPPORT SERVICES - OPERATION OF BUILDING	\$19,207.13	\$0.00	\$19,207.13	\$0.00	(\$19,207.13)
01-2-02610-210-000	Operation of Buildings-Group Insurance for Non- Instructional	\$24.27	\$0.00	\$24.27	\$0.00	(\$24.27)
01-2-02610-220-000	SUPPORT SERVICES - OPERATION OF BUILDING	\$1,431.68	\$0.00	\$1,431.68	\$0.00	(\$1,431.68)
01-2-02610-230-000	SUPPORT SERVICES - OPERATION OF BUILDING	\$1,875.20	\$0.00	\$1,875.20	\$0.00	(\$1,875.20)
01-2-02610-382-000	SUPPORT SERVICES - OPERATION OF BUILDING	\$2,052.76	\$0.00	\$2,052.76	\$0.00	(\$2,052.76)
01-2-02610-410-000	SUPPORT SERVICES - OPERATION OF BUILDING	\$10,993.70	\$0.00	\$10,993.70	\$0.00	(\$10,993.70)
01-2-02610-431-000	Operation of Buildings-Non-Technology-Related Repairs and Maintenance	\$91.00	\$0.00	\$91.00	\$0.00	(\$91.00)
01-2-02610-441-000	Operation of Buildings-Rentals of Land and Buildings	\$242.66	\$0.00	\$242.66	\$0.00	(\$242.66)
01-2-02610-610-000	Operation of Buildings-General Supplies	\$4,629.74	\$0.00	\$4,629.74	\$0.00	(\$4,629.74)
01-2-02610-610-001	Operation of Buildings-General Supplies-Sec	\$50.00	\$0.00	\$50.00	\$0.00	(\$50.00)
01-2-02610-621-000	Operation of Buildings-Natural Gas	\$206.74	\$0.00	\$206.74	\$0.00	(\$206.74)
01-2-02620-110-000	MAINTENANCE OF BUILDING	\$633.63	\$0.00	\$633.63	\$0.00	(\$633.63)
01-2-02620-220-000	Maintenance of Buildings-Social Security Payments for Non-Instructional	\$48.46	\$0.00	\$48.46	\$0.00	(\$48.46)
01-2-02620-230-000	Maintenance of Buildings-Retirement Contributions for Non-Instructional	\$20.86	\$0.00	\$20.86	\$0.00	(\$20.86)
01-2-02620-430-000	MAINTENANCE OF BUILDING	\$6,341.82	\$0.00	\$6,341.82	\$0.00	(\$6,341.82)
01-2-02620-431-000	Maintenance of Buildings-Non-Technology-Related Repairs and Maintenance	\$340.86	\$0.00	\$340.86	\$0.00	(\$340.86)
01-2-02630-110-000	Care and Upkeep of Grounds-Salaries of Regular Employees Paid to Non-Instructional	\$1,498.48	\$0.00	\$1,498.48	\$0.00	(\$1,498.48)

01-2-02630-220-000	Care and Upkeep of Grounds-Social Security Payments for Non-Instructional	\$114.64	\$0.00	\$114.64	\$0.00	(\$114.64)
01-2-02630-230-000	Care and Upkeep of Grounds-Retirement Contributions for Non-Instructional	\$148.02	\$0.00	\$148.02	\$0.00	(\$148.02)
01-2-02630-431-000	Care and Upkeep of Grounds-Non-Technology-Related Repairs and Maintenance	\$205.00	\$0.00	\$205.00	\$0.00	(\$205.00)
01-2-02630-626-000	Care and Upkeep of Grounds-Gasoline	\$90.67	\$0.00	\$90.67	\$0.00	(\$90.67)
01-2-02710-110-000	REGULAR PUPIL TRANSPORTATION	\$4,908.11	\$0.00	\$4,908.11	\$0.00	(\$4,908.11)
01-2-02710-110-001	REGULAR PUPIL TRANSPORTATION	\$2,744.81	\$0.00	\$2,744.81	\$0.00	(\$2,744.81)
01-2-02710-110-002	REGULAR PUPIL TRANSPORTATION	\$3,610.45	\$0.00	\$3,610.45	\$0.00	(\$3,610.45)
01-2-02710-111-000	Vehicle Operation and Purchasing - Regular Education-Salaries of Regular Employees Paid to Teachers/Professional Staff	\$22.00	\$0.00	\$22.00	\$0.00	(\$22.00)
01-2-02710-111-001	Vehicle Operation and Purchasing - Regular Education-Salaries of Regular Employees Paid to Teachers/Professional Staff See	\$1,864.13	\$0.00	\$1,864.13	\$0.00	(\$1,864.13)
01-2-02710-111-002	Vehicle Operation and Purchasing - Regular Education-Salaries of Regular Employees Paid to Teachers/Professional Staff Elem	\$2,232.00	\$0.00	\$2,232.00	\$0.00	(\$2,232.00)
01-2-02710-211-000	Vehicle Operation and Purchasing - Regular Education-Group Insurance for Teachers/Professional Staff	\$7.15	\$0.00	\$7.15	\$0.00	(\$7.15)
01-2-02710-211-001	Vehicle Operation and Purchasing - Regular Education-Group Insurance for Teachers/Professional Staff See	\$563.20	\$0.00	\$563.20	\$0.00	(\$563.20)
01-2-02710-211-002	Vehicle Operation and Purchasing - Regular Education-Group Insurance for Teachers/Professional Staff Elem	\$677.94	\$0.00	\$677.94	\$0.00	(\$677.94)
01-2-02710-220-000	REGULAR PUPIL TRANSPORTATION	\$375.50	\$0.00	\$375.50	\$0.00	(\$375.50)
01-2-02710-220-001	REGULAR PUPIL TRANSPORTATION	\$209.97	\$0.00	\$209.97	\$0.00	(\$209.97)
01-2-02710-220-002	REGULAR PUPIL TRANSPORTATION	\$276.20	\$0.00	\$276.20	\$0.00	(\$276.20)
01-2-02710-221-000	Vehicle Operation and Purchasing - Regular Education-Social Security Payments for Teachers/Professional Staff	\$1.62	\$0.00	\$1.62	\$0.00	(\$1.62)
01-2-02710-221-001	Vehicle Operation and Purchasing - Regular Education-Social Security Payments for Teachers/Professional Staff See	\$138.20	\$0.00	\$138.20	\$0.00	(\$138.20)
01-2-02710-221-002	Vehicle Operation and Purchasing - Regular Education-Social Security Payments for Teachers/Professional Staff Elem	\$165.46	\$0.00	\$165.46	\$0.00	(\$165.46)
01-2-02710-230-000	REGULAR PUPIL TRANSPORTATION	\$443.09	\$0.00	\$443.09	\$0.00	(\$443.09)
01-2-02710-230-001	Vehicle Operation and Purchasing - Regular Education-Retirement Contributions for Non-Instructional See	\$180.16	\$0.00	\$180.16	\$0.00	(\$180.16)
01-2-02710-230-002	REGULAR PUPIL TRANSPORTATION	\$262.36	\$0.00	\$262.36	\$0.00	(\$262.36)
01-2-02710-231-000	Vehicle Operation and Purchasing - Regular Education-Retirement Contributions for Teachers/Professional Staff	\$2.17	\$0.00	\$2.17	\$0.00	(\$2.17)
01-2-02710-231-001	Vehicle Operation and Purchasing - Regular Education-Retirement Contributions for Teachers/Professional Staff See	\$184.15	\$0.00	\$184.15	\$0.00	(\$184.15)
01-2-02710-231-002	Vehicle Operation and Purchasing - Regular Education-Retirement Contributions for Teachers/Professional Staff Elem	\$220.47	\$0.00	\$220.47	\$0.00	(\$220.47)
01-2-02710-340-000	Vehicle Operation and Purchasing - Regular Education-Other Professional Services	\$152.00	\$0.00	\$152.00	\$0.00	(\$152.00)
01-2-02710-382-000	REGULAR PUPIL TRANSPORTATION	\$112.50	\$0.00	\$112.50	\$0.00	(\$112.50)
01-2-02710-626-000	Vehicle Operation and Purchasing - Regular Education-Gasoline	\$3,330.43	\$0.00	\$3,330.43	\$0.00	(\$3,330.43)

01-2-02712-110-001	Vehicle Operation and Purchasing - School Age SPED-Salaries of Regular Employees Paid to Non-Instructional Sec	\$198.52	\$0.00	\$198.52	\$0.00	(\$198.52)
01-2-02712-110-002	SCHOOL AGE SPECIAL EDUCATION PUPIL TRANSPORTATION	\$198.52	\$0.00	\$198.52	\$0.00	(\$198.52)
01-2-02712-220-001	Vehicle Operation and Purchasing - School Age SPED-Social Security Payments for Non-Instructional Sec	\$15.19	\$0.00	\$15.19	\$0.00	(\$15.19)
01-2-02712-220-002	SCHOOL AGE SPECIAL EDUCATION PUPIL TRANSPORTATION	\$15.19	\$0.00	\$15.19	\$0.00	(\$15.19)
01-2-02712-230-001	Vehicle Operation and Purchasing - School Age SPED-Retirement Contributions for Non-Instructional Sec	\$1.73	\$0.00	\$1.73	\$0.00	(\$1.73)
01-2-02712-230-002	Vehicle Operation and Purchasing - School Age SPED-Retirement Contributions for Non-Instructional Elem	\$1.73	\$0.00	\$1.73	\$0.00	(\$1.73)
01-2-02712-626-000	Vehicle Operation and Purchasing - School Age SPED-Gasoline	\$137.60	\$0.00	\$137.60	\$0.00	(\$137.60)
01-2-02730-431-000	Vehicle Servicing and Maintenance - Regular Education-Non-Technology-Related Repairs and Maintenance	\$43.70	\$0.00	\$43.70	\$0.00	(\$43.70)
01-2-02730-732-000	Vehicle Servicing and Maintenance - Regular Education-Vehicles	\$3,497.47	\$0.00	\$3,497.47	\$0.00	(\$3,497.47)
01-2-02732-732-000	Vehicle Servicing and Maintenance - School Age SPED-Vehicles	\$100.00	\$0.00	\$100.00	\$0.00	(\$100.00)
01-2-02790-382-000	Other Student Transportation Services - Regular Students-Distance Education & Telecommunications	\$200.00	\$0.00	\$200.00	\$0.00	(\$200.00)
01-2-02792-580-001	Other Student Transportation Services - School Age SPED-Travel-Sec	\$525.11	\$0.00	\$525.11	\$0.00	(\$525.11)
01-2-02792-580-002	Other Student Transportation Services - School Age SPED-Travel-Elem	\$224.25	\$0.00	\$224.25	\$0.00	(\$224.25)
01-2-02900-810-000	Other Support Services-Dues and Fees	\$100.00	\$0.00	\$100.00	\$0.00	(\$100.00)
01-2-06200-111-002	Federal Services - Title I, Part A ESSA Improving Basic Programs Operated by Local Educational Agencies-Salaries of Regular Employees Paid to Teachers/Professional Staff Elem	\$15,498.00	\$0.00	\$15,498.00	\$0.00	(\$15,498.00)
01-2-06200-211-002	Federal Services - Title I, Part A ESSA Improving Basic Programs Operated by Local Educational Agencies-Group Insurance for Teachers/Professional Staff Elem	\$5,931.27	\$0.00	\$5,931.27	\$0.00	(\$5,931.27)
01-2-06200-221-002	Federal Services - Title I, Part A ESSA Improving Basic Programs Operated by Local Educational Agencies-Social Security Payments for Teachers/Professional Staff Elem	\$1,133.10	\$0.00	\$1,133.10	\$0.00	(\$1,133.10)
01-2-06200-231-002	Federal Services - Title I, Part A ESSA Improving Basic Programs Operated by Local Educational Agencies-Retirement Contributions for Teachers/Professional Staff Elem	\$1,530.87	\$0.00	\$1,530.87	\$0.00	(\$1,530.87)
01-2-06200-610-002	Federal Services - Title I, Part A ESSA Improving Basic Programs Operated by Local Educational Agencies-General Supplies Elem	\$125.16	\$0.00	\$125.16	\$0.00	(\$125.16)
01-2-06210-221-002	Federal Services - Title I, Part A Accountability ESSA Improving Basic Programs Accountability-Social Security Payments for Teachers/Professional Staff Elem	\$765.00	\$0.00	\$765.00	\$0.00	(\$765.00)
01-2-06210-231-002	Federal Services - Title I, Part A Accountability ESSA Improving Basic Programs Accountability-Retirement Contributions for Teachers/Professional Staff Elem	\$10,000.00	\$0.00	\$10,000.00	\$0.00	(\$10,000.00)

01-2-06408-591-001	IDEA Part B (611) Base & Enrollment Poverty Allocation Ages 0-21-Services Purchased From Another School District or Educational Services	\$8,400.00	\$0.00	\$8,400.00	\$0.00	(\$8,400.00)
01-2-06408-591-002	IDEA Part B (611) Base & Enrollment Poverty Allocation Ages 0-21-Services Purchased From Another School District or Educational Services	\$4,648.66	\$0.00	\$4,648.66	\$0.00	(\$4,648.66)
01-2-06992-734-000	Federal Services - REAP-Technology-Related Hardware	\$23,939.00	\$0.00	\$23,939.00	\$0.00	(\$23,939.00)
02-2-02900-430-000	Other Support Services-Repairs and Maintenance Services	\$14,139.00	\$0.00	\$14,139.00	\$0.00	(\$14,139.00)
05-2-02900-352-001	Refs	\$3,345.00	\$0.00	\$3,345.00	\$0.00	(\$3,345.00)
05-2-02900-610-000	Other Support Services-General Supplies	\$3,036.48	\$0.00	\$3,036.48	\$0.00	(\$3,036.48)
05-2-02900-610-001	supplies	\$14,192.33	\$0.00	\$14,192.33	\$1,680.40	(\$15,872.73)
05-2-02900-810-001	Other Support Services-Dues and Fees-Sec	\$2,169.00	\$0.00	\$2,169.00	\$0.00	(\$2,169.00)
06-1-01611-000-000	Daily Sales?School Lunch Program	(\$5,621.32)	\$0.00	(\$5,621.32)	\$0.00	\$5,621.32
06-1-03100-610-000	Food Services Operations-General Supplies	\$213.70	\$0.00	\$213.70	\$0.00	(\$213.70)
06-1-03100-630-000	Food Services Operations-School Nutrition Food	\$1,947.80	\$0.00	\$1,947.80	\$0.00	(\$1,947.80)
06-2-03100-110-000	Food Services Operations-Salaries of Regular Employees Paid to Non-Instructional	\$18,494.12	\$0.00	\$18,494.12	\$0.00	(\$18,494.12)
06-2-03100-210-000	Food Services Operations-Group Insurance for Non-Instructional	\$15.78	\$0.00	\$15.78	\$0.00	(\$15.78)
06-2-03100-220-000	Food Services Operations-Social Security Payments for Non-Instructional	\$1,404.48	\$0.00	\$1,404.48	\$0.00	(\$1,404.48)
06-2-03100-230-000	Food Services Operations-Retirement Contributions for Non-Instructional	\$1,826.80	\$0.00	\$1,826.80	\$0.00	(\$1,826.80)
06-2-03100-330-000	Food Services Operations-Employee Training and Development Services	\$20.00	\$0.00	\$20.00	\$0.00	(\$20.00)
06-2-03100-610-000	Food Services Operations-General Supplies	\$1,276.48	\$0.00	\$1,276.48	\$0.00	(\$1,276.48)
06-2-03100-630-000	Food Services Operations-School Nutrition Food	\$19,465.89	\$0.00	\$19,465.89	\$0.00	(\$19,465.89)
07-1-01100-000-000	Taxes Levied/Assessed by the School District	(\$53,627.31)	\$0.00	(\$53,627.31)	\$0.00	\$53,627.31
07-1-01115-000-000	CARLINE TAXES	(\$70.32)	\$0.00	(\$70.32)	\$0.00	\$70.32
07-1-01140-000-000	Penalties and Interest on Taxes	(\$95.45)	\$0.00	(\$95.45)	\$0.00	\$95.45
07-1-03180-000-000	PRO-RATE MOTOR VEHICLE	(\$39.84)	\$0.00	(\$39.84)	\$0.00	\$39.84
07-2-05000-831-000	Debt Service-Redemption of Principal	\$150,000.00	\$0.00	\$150,000.00	\$0.00	(\$150,000.00)
07-2-05000-832-000	Debt Service-Interest on Long-Term Debt	\$9,931.25	\$0.00	\$9,931.25	\$0.00	(\$9,931.25)
07-2-05000-890-000	Debt Service-Miscellaneous Expenditures	\$200.00	\$0.00	\$200.00	\$0.00	(\$200.00)
08-1-01100-000-000	Taxes Levied/Assessed by the School District	(\$28,487.78)	\$0.00	(\$28,487.78)	\$0.00	\$28,487.78
08-1-01115-000-000	CARLINE TAXES	(\$37.33)	\$0.00	(\$37.33)	\$0.00	\$37.33
08-1-01140-000-000	Penalties and Interest on Taxes	(\$68.06)	\$0.00	(\$68.06)	\$0.00	\$68.06
08-1-03180-000-000	PRO-RATE MOTOR VEHICLE	(\$21.15)	\$0.00	(\$21.15)	\$0.00	\$21.15
09-1-01100-000-000	Taxes Levied/Assessed by the School District	(\$22,875.44)	\$0.00	(\$22,875.44)	\$0.00	\$22,875.44
09-1-01115-000-000	CARLINE TAXES	(\$29.99)	\$0.00	(\$29.99)	\$0.00	\$29.99
09-1-01140-000-000	Penalties and Interest on Taxes	(\$42.29)	\$0.00	(\$42.29)	\$0.00	\$42.29
09-1-03180-000-000	PRO-RATE MOTOR VEHICLE	(\$16.99)	\$0.00	(\$16.99)	\$0.00	\$16.99
09-2-05000-831-000	Debt Service-Redemption of Principal	\$65,000.00	\$0.00	\$65,000.00	\$0.00	(\$65,000.00)
09-2-05000-832-000	Debt Service-Interest on Long-Term Debt	\$3,587.50	\$0.00	\$3,587.50	\$0.00	(\$3,587.50)
09-2-05000-890-000	Debt Service-Miscellaneous Expenditures	\$200.00	\$0.00	\$200.00	\$0.00	(\$200.00)
10-2-01100-111-001	Regular Instruction-Salaries of Regular Employees Paid to Teachers/Professional Staff-Sec	\$4,538.76	\$0.00	\$4,538.76	\$0.00	(\$4,538.76)

10-2-01100-211-001	Regular Instruction-Group Insurance for Teachers/Professional Staff-Sec	\$1,779.48	\$0.00	\$1,779.48	\$0.00	(\$1,779.48)
10-2-01100-221-001	Regular Instruction-Social Security Payments for Teachers/Professional Staff-Sec	\$334.71	\$0.00	\$334.71	\$0.00	(\$334.71)
10-2-01100-231-001	Regular Instruction-Retirement Contributions for Teachers/Professional Staff-Sec	\$448.32	\$0.00	\$448.32	\$0.00	(\$448.32)
12-1-01740-000-000	Fees	(\$50.00)	\$0.00	(\$50.00)	\$0.00	\$50.00
12-2-02580-432-001	Administrative Technology Service-Technology-Related Repairs and Maintenance-Sec	\$198.00	\$0.00	\$198.00	\$0.00	(\$198.00)
Sub Total		\$169,825.25	\$0.00	\$169,825.25	\$8,905.79	(\$178,731.04)

0.00
0.00
0.00
0.00
0.00
0.00

Sterling Public Schools

Cash Summary Report

Accounting Cycle: FY20/21; Beginning Period: Period 02 (10/01/2020 - 10/31/2020) ; Ending Period: Period 02 (10/01/2020 - 10/31/2020) ; Show Prior Year Expense/Encumbrance: No; Pri
Balance: Yes; Include Transactions after the Last Period: None; Exclude Closing Entries: No; Include Unposted Transactions: Yes; Created On: 11/12/2020 12:36:00 PM

Fund	Description	Beginning Balance	Revenue	Expenditure	Other	Ending Balance	Encumbrances
01	General Fund	\$136,749.14	\$181,981.49	(\$281,229.26)	\$0.00	\$37,501.37	(\$6,262.57)
02	Depreciation Fund	\$381,290.37	\$0.00	\$0.00	\$0.00	\$381,290.37	\$0.00
03	Employee Benefit Fund	\$0.00	\$0.00	\$0.00	\$0.00	\$0.00	\$0.00
05	Activity Fund	\$24,418.49	\$0.00	(\$12,897.54)	\$0.00	\$11,520.95	(\$1,680.40)
06	School Nutrition Fund	\$2,197.59	\$530.50	(\$15,108.68)	\$0.00	(\$12,380.59)	\$0.00
07	Bond Fund	\$119,294.35	\$9,682.33	\$0.00	\$0.00	\$128,976.68	\$0.00
08	Special Building Fund	\$375,555.15	\$5,172.74	\$0.00	\$0.00	\$380,727.89	\$0.00
09	QCPUF Fund	\$90,857.16	\$4,132.40	\$0.00	\$0.00	\$94,989.56	\$0.00
10	Cooperative Fund	\$9,170.25	\$0.00	(\$2,367.09)	\$0.00	\$6,803.16	\$0.00
12	Student Fees Fund	\$521.45	\$0.00	(\$99.00)	\$0.00	\$422.45	\$0.00
Sub Total		\$1,140,053.95	\$201,499.46	(\$311,701.57)	\$0.00	\$1,029,851.84	(\$7,942.97)

for Year Ending Balance for Beginning

Liabilities	Available
\$0.00	\$31,238.80
\$0.00	\$381,290.37
\$0.00	\$0.00
\$0.00	\$9,840.55
\$0.00	(\$12,380.59)
\$0.00	\$128,976.68
\$0.00	\$380,727.89
\$0.00	\$94,989.56
\$0.00	\$6,803.16
\$0.00	\$422.45
\$0.00	\$1,021,908.87

Sterling Public Schools

Cash Summary Report

Accounting Cycle: FY20/21; Beginning Period: Period 02 (10/01/2020 - 10/31/2020) ; Ending Period: Period 02 (10/01/2020 - 10/31/2020) ;
Show Prior Year Expense/Encumbrance: No; Prior Year Ending Balance for Beginning Balance: Yes; Include Transactions after the Last Period:
None; Exclude Closing Entries: No; Include Unposted Transactions: Yes; Created On: 11/12/2020 12:36:00 PM

Fund	Description	Liabilities (Beginning)	Liabilities (Ending)	Cash Journal Entries	Other Total
01	General Fund	\$0.00	\$0.00	\$0.00	\$0.00
02	Depreciation Fund	\$0.00	\$0.00	\$0.00	\$0.00
05	Activity Fund	\$0.00	\$0.00	\$0.00	\$0.00
06	School Nutrition Fund	\$0.00	\$0.00	\$0.00	\$0.00
07	Bond Fund	\$0.00	\$0.00	\$0.00	\$0.00
08	Special Building Fund	\$0.00	\$0.00	\$0.00	\$0.00
09	QCPUF Fund	\$0.00	\$0.00	\$0.00	\$0.00
10	Cooperative Fund	\$0.00	\$0.00	\$0.00	\$0.00
12	Student Fees Fund	\$0.00	\$0.00	\$0.00	\$0.00
Sub Total		\$0.00	\$0.00	\$0.00	\$0.00

Sterling Public Schools

Check Report

Begin Date: 10/22/2020; End Date: 11/12/2020; Check Type: Accounts Payable and Payroll Liability; Payee: [All]; Bank: [All]; Accounting Cycle: FY20/21; Limit Results to This Cycle: Yes; Account Expression: [All]; Show Detail by Voucher: Yes; Created On: 11/12/2020 12:27:45 PM

Check Date	Check Number	Payee	Type	Amount
10/23/2020	14658	Appleby, Kelsey	Accounts Payable	\$90.00
10/23/2020	14659	Colby Thies	Accounts Payable	\$25.00
10/23/2020	14660	Dorchester Public School	Accounts Payable	\$75.00
10/23/2020	14661	Falls City Public School	Accounts Payable	\$110.00
10/23/2020	14662	First Bank of Nebraska	Accounts Payable	\$460.00
10/23/2020	14663	FREEMAN PUBLIC SCHOOL	Accounts Payable	\$150.00
10/23/2020	14664	HARCO ATHLETIC RECONDITIONING INC	Accounts Payable	\$1,354.00
10/23/2020	14665	Mahaska-Pepsi	Accounts Payable	\$320.00
10/23/2020	14666	Merz Ink	Accounts Payable	\$272.79
10/23/2020	14667	Scott Cafe	Accounts Payable	\$275.50
10/23/2020	14668	SDA Public Schools	Accounts Payable	\$110.00
10/23/2020	14669	Simons, Kady	Accounts Payable	\$90.00
10/23/2020	14670	Thies, Erika	Accounts Payable	\$25.00
10/26/2020	14671	Club's Choice	Accounts Payable	\$3,683.00
10/29/2020	30189	SEDIVY, JENNA	Accounts Payable	\$205.69
10/30/2020	14672	Clark, Lance	Accounts Payable	\$86.00
10/30/2020	14673	First Bank of Nebraska	Accounts Payable	\$810.00
10/30/2020	14674	Hall, Nathan	Accounts Payable	\$86.00
10/30/2020	14675	Harman, Mark	Accounts Payable	\$86.00
10/30/2020	14676	Mitchell, Miguelito	Accounts Payable	\$86.00
10/30/2020	14677	Russell Johnson	Accounts Payable	\$86.00
11/03/2020	14678	Amazon Capital Services	Accounts Payable	\$111.88
11/03/2020	14679	CORPORATE PAYMENT SYSTEMS	Accounts Payable	\$2,285.54
11/03/2020	14680	JET STOP INC.	Accounts Payable	\$48.87
11/03/2020	14681	Mahaska-Pepsi	Accounts Payable	\$826.00
11/03/2020	14682	POST PROM	Accounts Payable	\$79.50
11/03/2020	14683	Sterling Booster Club	Accounts Payable	\$318.00
11/03/2020	14684	TeamMates - Sterling	Accounts Payable	\$159.00
11/06/2020	14685	First Bank of Nebraska	Accounts Payable	\$940.00
11/06/2020	14686	Axline, Dustin	Accounts Payable	\$84.00
11/06/2020	14687	Cash-wa Distribution	Accounts Payable	\$537.68
11/06/2020	14688	NSAA	Accounts Payable	\$646.70
11/06/2020	14689	Ruhl, Anthony	Accounts Payable	\$84.00
11/06/2020	14690	Ruhl, Dale	Accounts Payable	\$84.00
11/06/2020	14691	Ruhl, Robert	Accounts Payable	\$84.00
11/06/2020	14692	Schlegelmilch, Mitchell	Accounts Payable	\$84.00
11/06/2020	14693	Southwest Public School	Accounts Payable	\$592.10
11/12/2020	30200	Aflac	Payroll Liability	\$1,071.37

11/12/2020	30201	Ameritas	Payroll Liability	\$142.28
11/12/2020	30202	Blue Cross/Blue Shield	Payroll Liability	\$31,678.66
11/12/2020	30203	Credit Management Services v. Angela Heidtbrink	Payroll Liability	\$28.96
11/12/2020	30204	First Bank of NE credit A Allen HSA	Payroll Liability	\$100.00
11/12/2020	30205	First Bank of NE credit A Heusman HSA account	Payroll Liability	\$200.00
11/12/2020	30206	Tax Checks	Payroll Liability	\$36,280.05
11/12/2020	30207	Kathleen A Laughlin, Chapter 13 Trustee	Payroll Liability	\$254.00
11/12/2020	30208	Nebraska Department of Revenue	Payroll Liability	\$204.12
11/12/2020	30209	Nebraska Dept Of Revenue	Payroll Liability	\$5,047.00
11/12/2020	30210	Nebraska Retirement	Payroll Liability	\$32,132.40
11/12/2020	30211	PRINCIPAL LIFE GROUP	Payroll Liability	\$492.85
11/12/2020	30212	SECURITY BENEFIT	Payroll Liability	\$3,500.00
11/12/2020	30213	WageWorks, Inc	Payroll Liability	\$1,642.52
11/12/2020	30214	Acco Brands	Accounts Payable	\$37.50
11/12/2020	30215	Al's Johns	Accounts Payable	\$121.33
11/12/2020	30216	Allen, Adrian W	Accounts Payable	\$50.00
11/12/2020	30217	Amazon Capital Services	Accounts Payable	\$1,570.28
11/12/2020	30218	Bernard Food Ind. Inc	Accounts Payable	\$220.32
11/12/2020	30219	Boden, Ronald R	Accounts Payable	\$25.00
11/12/2020	30220	BOK FINANCIAL	Accounts Payable	\$228,918.75
11/12/2020	30221	Boldt, Luke M	Accounts Payable	\$25.00
11/12/2020	30222	Boslau, Dennis R	Accounts Payable	\$25.00
11/12/2020	30223	CAPITAL BUSINESS SYSTEMS, INC	Accounts Payable	\$2,557.11
11/12/2020	30224	Carpenter, Jay N	Accounts Payable	\$12.50
11/12/2020	30225	Cash-wa Distribution	Accounts Payable	\$814.44
11/12/2020	30226	CULLIGAN OF LINCOLN	Accounts Payable	\$528.19
11/12/2020	30227	DAVENPORT, JACOB M	Accounts Payable	\$50.00
11/12/2020	30228	Dietze Music House	Accounts Payable	\$9.90
11/12/2020	30229	Diversified Drug Testing	Accounts Payable	\$50.00
11/12/2020	30230	EGAN SUPPLY CO	Accounts Payable	\$1,137.53
11/12/2020	30231	ESU #4	Accounts Payable	\$35,643.33
11/12/2020	30232	ESU #6	Accounts Payable	\$77.50
11/12/2020	30233	FILTER SHOP	Accounts Payable	\$664.21
11/12/2020	30234	FUN & FUNCTION	Accounts Payable	\$14.90
11/12/2020	30235	Hancock Lumber, LLC	Accounts Payable	\$51.96
11/12/2020	30236	HARRIS SCHOOL SOLUTIONS	Accounts Payable	\$209.20
11/12/2020	30237	Heusman, Brent J	Accounts Payable	\$25.00
11/12/2020	30238	HILAND DAIRY	Accounts Payable	\$1,604.45
11/12/2020	30239	Innovative	Accounts Payable	\$2,100.53
11/12/2020	30240	JET STOP INC.	Accounts Payable	\$1,419.73
11/12/2020	30241	Johnson County Hospital	Accounts Payable	\$1,766.80
11/12/2020	30242	KSB SCHOOL LAW	Accounts Payable	\$989.28
11/12/2020	30243	KUDU LAWN CARE	Accounts Payable	\$205.00
11/12/2020	30244	Life Track Services	Accounts Payable	\$174.00

11/12/2020	30245	MARSHALL KATIE B	Accounts Payable	\$115.38
11/12/2020	30246	Matheson Trigas DBA Linweld	Accounts Payable	\$34.62
11/12/2020	30247	Menards	Accounts Payable	\$116.07
11/12/2020	30248	Nebraska Public Power Distric	Accounts Payable	\$3,190.37
11/12/2020	30249	O'keefe Elevator Company, Inc.	Accounts Payable	\$340.86
11/12/2020	30250	ONE SOURCE	Accounts Payable	\$25.00
11/12/2020	30251	PYRAMID SCHOOL PRODUCTS	Accounts Payable	\$1,192.85
11/12/2020	30252	Recycling Enterprises	Accounts Payable	\$60.00
11/12/2020	30253	School Specialty	Accounts Payable	\$27.10
11/12/2020	30254	Sprague, Ida Rose	Accounts Payable	\$73.90
11/12/2020	30255	SYSCO OF LINCOLN	Accounts Payable	\$6,069.42
11/12/2020	30256	T.O. Haas	Accounts Payable	\$43.70
11/12/2020	30257	Tecumseh Chieftain	Accounts Payable	\$196.08
11/12/2020	30258	The Home Depot Pro	Accounts Payable	\$120.16
11/12/2020	30259	Trane US, Inc	Accounts Payable	\$57.25
11/12/2020	30260	U.S. Cellular	Accounts Payable	\$42.46
11/12/2020	30261	UNITE PRIVATE NETWORKS, LLC	Accounts Payable	\$554.00
11/12/2020	30262	United States Postal Service	Accounts Payable	\$7.75
11/12/2020	30263	Village Of Sterling	Accounts Payable	\$172.00
11/12/2020	30264	WageWorks, Inc	Accounts Payable	\$50.00
11/12/2020	30265	WASTE CONNECTIONS OF NEBRASKA	Accounts Payable	\$400.00
11/12/2020	30266	Waymire Well Drilling, Inc.	Accounts Payable	\$91.00
11/12/2020	30267	WINDSTREAM COMMUNICATIONS, INC	Accounts Payable	\$806.28
11/12/2020	30268	Wirthele, Cheri J	Accounts Payable	\$25.00
11/12/2020	EFT	Direct Deposit Bank	Payroll Liability	\$119,316.50
Sub Total				\$542,451.95

Sterling Public Schools

Check Report

Begin Date: 10/22/2020; End Date: 11/12/2020; Check Type: Accounts Payable and Payroll Liability; Payee: [All]; Bank: [All]; Accounting Cycle: FY20/21; Limit Results to This Cycle: Yes; Account Exp [All]; Show Detail by Voucher: Yes; Created On: 11/12/2020 12:27:45 PM

Payee	Check Date	Check Number	Description	Type	Amount
Acco Brands	11/12/2020	30214	Inv: 4712981633, 4713671613	Accounts Payable	\$37.50
Aflac	11/12/2020	30200	Aflac Accident Ins	Payroll Liability	\$534.09
Aflac	11/12/2020	30200	Aflac Cancer PreTax	Payroll Liability	\$320.83
Aflac	11/12/2020	30200	Aflac Hospital	Payroll Liability	\$66.43
Aflac	11/12/2020	30200	Aflac Special Event	Payroll Liability	\$150.02
Al's Johns	11/12/2020	30215	Inv: 37516	Accounts Payable	\$121.33
Allen, Adrian W	11/12/2020	30216	Inv: October cellphone	Accounts Payable	\$50.00
Amazon Capital Services	11/03/2020	14678	FFA fruit sales rewards	Accounts Payable	\$111.88
Amazon Capital Services	11/12/2020	30217	Inv: 11w1-gtff-76jf	Accounts Payable	\$21.90
Amazon Capital Services	11/12/2020	30217	Inv: 1kc1-4pm7-6t4m	Accounts Payable	\$22.01
Amazon Capital Services	11/12/2020	30217	Inv: 1md3-9qn7-jj6m	Accounts Payable	\$21.98
Amazon Capital Services	11/12/2020	30217	Inv: 1r9w-m1v6-nrpk	Accounts Payable	\$239.94
Amazon Capital Services	11/12/2020	30217	Inv: 1vgj-ffwq-hfhj	Accounts Payable	\$413.81
Amazon Capital Services	11/12/2020	30217	Inv: 1vx7-q7lq-74fm	Accounts Payable	\$88.52
Amazon Capital Services	11/12/2020	30217	Inv: 1vx7-q7lq-w9yq	Accounts Payable	\$12.99
Amazon Capital Services	11/12/2020	30217	Inv: 1xcl-gc46-3pdh	Accounts Payable	\$112.59
Amazon Capital Services	11/12/2020	30217	Inv: ifh9-74pn-6pjj	Accounts Payable	\$223.15
Amazon Capital Services	11/12/2020	30217	Inv: ijnr-gwl1-4jvh	Accounts Payable	\$37.89
Amazon Capital Services	11/12/2020	30217	Inv: itj4-dlcj-3n4c	Accounts Payable	\$24.34
Amazon Capital Services	11/12/2020	30217	Mimio Projector Bulb Elementary	Accounts Payable	\$139.89
Amazon Capital Services	11/12/2020	30217	Wall Mount Rack Enclosure Server Cabinet - Weight Room Switch and fiber	Accounts Payable	\$211.27
Ameritas	11/12/2020	30201	Vision Ins E/Sp	Payroll Liability	\$13.48
Ameritas	11/12/2020	30201	Vision Ins Fam	Payroll Liability	\$72.64
Ameritas	11/12/2020	30201	Vision Ins Single	Payroll Liability	\$56.16
Appleby, Kelsey	10/23/2020	14658	ref vb vs j-b	Accounts Payable	\$90.00
Axline, Dustin	11/06/2020	14686	ref fb playoffs	Accounts Payable	\$84.00
Bernard Food Ind. Inc	11/12/2020	30218	Inv: 00861932	Accounts Payable	\$220.32
Blue Cross/Blue Shield	11/12/2020	30202	BCBS Dental-Dist Pd Single	Payroll Liability	\$590.80
Blue Cross/Blue Shield	11/12/2020	30202	BCBS Medical-Dist Pd E/Sp	Payroll Liability	\$1,436.65
Blue Cross/Blue Shield	11/12/2020	30202	BCBS Medical-Dist Pd Fam	Payroll Liability	\$17,361.45
Blue Cross/Blue Shield	11/12/2020	30202	BCBS Medical-Dist Pd Fam HD	Payroll Liability	\$8,137.95
Blue Cross/Blue Shield	11/12/2020	30202	BCBS Medical-Dist Pd Single	Payroll Liability	\$3,420.60
Blue Cross/Blue Shield	11/12/2020	30202	Dental Ins E/Sp	Payroll Liability	\$32.46
Blue Cross/Blue Shield	11/12/2020	30202	Dental Ins Fam	Payroll Liability	\$698.75
Boden, Ronald R	11/12/2020	30219	Inv: October cellphone	Accounts Payable	\$25.00
BOK FINANCIAL	11/12/2020	30220	Inv: jcsd33ltos14-QCPUF	Accounts Payable	\$68,787.50
BOK FINANCIAL	11/12/2020	30220	Inv: jcsdgorb2012-BOND	Accounts Payable	\$160,131.25

Boldt, Luke M	11/12/2020	30221	Inv: October cellphone	Accounts Payable	\$25.00
Boslau, Dennis R	11/12/2020	30222	Inv: October cellphone	Accounts Payable	\$25.00
CAPITAL BUSINESS SYSTEMS, INC	11/12/2020	30223	Inv: 28020182	Accounts Payable	\$2,557.11
Carpenter, Jay N	11/12/2020	30224	Inv: October Cellphone	Accounts Payable	\$12.50
Cash-wa Distribution	11/06/2020	14687	concessions	Accounts Payable	\$537.68
Cash-wa Distribution	11/12/2020	30225	Inv: 12659577	Accounts Payable	\$32.95
Cash-wa Distribution	11/12/2020	30225	Inv: 12668058	Accounts Payable	\$781.49
Clark, Lance	10/30/2020	14672	ref fb playoffs SWRR	Accounts Payable	\$86.00
Club's Choice	10/26/2020	14671	Band/Choir Fundraiser	Accounts Payable	\$3,683.00
Colby Thies	10/23/2020	14659	lines vb vs. j-b	Accounts Payable	\$25.00
CORPORATE PAYMENT SYSTEMS	11/03/2020	14679	Sept Oct credit card	Accounts Payable	\$2,285.54
Credit Management Services v. Angela Heidtbrink	11/12/2020	30203	Credit Management Services v. Angela Heidtbrink	Payroll Liability	\$28.96
CULLIGAN OF LINCOLN	11/12/2020	30226	Inv: 201517-kitchen	Accounts Payable	\$342.25
CULLIGAN OF LINCOLN	11/12/2020	30226	Inv: 85659	Accounts Payable	\$144.87
CULLIGAN OF LINCOLN	11/12/2020	30226	Inv: 85660	Accounts Payable	\$13.87
CULLIGAN OF LINCOLN	11/12/2020	30226	Inv: 85661	Accounts Payable	\$27.20
DAVENPORT, JACOB M	11/12/2020	30227	Inv: October Cellphone	Accounts Payable	\$50.00
Dietze Music House	11/12/2020	30228	Inv: TA7226	Accounts Payable	\$9.90
Direct Deposit Bank	11/12/2020	EFT	Direct Deposit	Payroll Liability	\$119,316.50
Diversified Drug Testing	11/12/2020	30229	Inv: 2021 membership dues	Accounts Payable	\$50.00
Dorchester Public School	10/23/2020	14660	Dorchester JH VB tournament	Accounts Payable	\$75.00
EGAN SUPPLY CO	11/12/2020	30230	Inv: 320012A, 327704	Accounts Payable	\$257.88
EGAN SUPPLY CO	11/12/2020	30230	Inv: 325841A	Accounts Payable	\$116.50
EGAN SUPPLY CO	11/12/2020	30230	Inv: 327642	Accounts Payable	\$763.15
ESU #4	11/12/2020	30231	Inv: 9417-McCormick	Accounts Payable	\$20,000.00
ESU #4	11/12/2020	30231	Inv: October Billing date	Accounts Payable	\$15,643.33
ESU #6	11/12/2020	30232	Inv: 14334	Accounts Payable	\$77.50
Falls City Public School	10/23/2020	14661	Falls City VB tournament	Accounts Payable	\$110.00
FILTER SHOP	11/12/2020	30233	Inv: 145514	Accounts Payable	\$274.24
FILTER SHOP	11/12/2020	30233	Inv: 146843	Accounts Payable	\$389.97
First Bank of NE credit A Allen HSA	11/12/2020	30204	Adrian Allen HSA account Employee Deduction	Payroll Liability	\$100.00
First Bank of NE credit A Heusman HSA account	11/12/2020	30205	Addie Heusman HSA account Employee Deduction	Payroll Liability	\$200.00
First Bank of Nebraska	10/23/2020	14662	gate con vb vs. j-b	Accounts Payable	\$460.00
First Bank of Nebraska	10/30/2020	14673	gate con fb playoff SWRR	Accounts Payable	\$810.00
First Bank of Nebraska	11/06/2020	14685	con, gate fb playoffs	Accounts Payable	\$940.00
FREEMAN PUBLIC SCHOOL	10/23/2020	14663	Freeman VB tournament	Accounts Payable	\$150.00
FUN & FUNCTION	11/12/2020	30234	C Pella Vision 2020	Accounts Payable	\$14.90
Hall, Nathan	10/30/2020	14674	ref fb playoffs SWRR	Accounts Payable	\$86.00
Hancock Lumber, LLC	11/12/2020	30235	Inv: 000602	Accounts Payable	\$25.98
Hancock Lumber, LLC	11/12/2020	30235	Inv: 00602	Accounts Payable	\$25.98
HARCO ATHLETIC RECONDITIONING INC	10/23/2020	14664	football helmet reconditioning	Accounts Payable	\$1,354.00
Harman, Mark	10/30/2020	14675	ref fb playoffs SWRR	Accounts Payable	\$86.00
HARRIS SCHOOL SOLUTIONS	11/12/2020	30236	Inv: XT00167933	Accounts Payable	\$209.20
Heusman, Brent J	11/12/2020	30237	Inv: October cellphone	Accounts Payable	\$25.00

HILAND DAIRY	11/12/2020	30238	Inv: October Invoices	Accounts Payable	\$1,604.45
Innovative	11/12/2020	30239	Inv: teacher supplies 19/20	Accounts Payable	\$2,100.53
JET STOP INC.	11/03/2020	14680	college access	Accounts Payable	\$48.87
JET STOP INC.	11/12/2020	30240	Inv: 4556	Accounts Payable	\$1,419.73
Johnson County Hospital	11/12/2020	30241	Inv: Jay Carpenter physical	Accounts Payable	\$152.00
Johnson County Hospital	11/12/2020	30241	Inv: OT October Bill	Accounts Payable	\$1,448.64
Johnson County Hospital	11/12/2020	30241	Inv: PT October bill	Accounts Payable	\$166.16
Kathleen A Laughlin, Chapter 13 Trustee	11/12/2020	30207	Kathleen A. Laughlin, Chapter 13 Trustee	Payroll Liability	\$254.00
KSB SCHOOL LAW	11/12/2020	30242	Inv: 9098	Accounts Payable	\$989.28
KUDU LAWN CARE	11/12/2020	30243	Inv: 10102220	Accounts Payable	\$205.00
Life Track Services	11/12/2020	30244	program a--3 surveys	Accounts Payable	\$174.00
Mahaska-Pepsi	10/23/2020	14665	concessions	Accounts Payable	\$320.00
Mahaska-Pepsi	11/03/2020	14681	concessions	Accounts Payable	\$826.00
MARSHALL KATIE B	11/12/2020	30245	Inv: reimb.	Accounts Payable	\$115.38
Matheson Trigas DBA Linweld	11/12/2020	30246	Inv: 51706741	Accounts Payable	\$34.62
Menards	11/12/2020	30247	Inv: 47644	Accounts Payable	\$116.07
Merz Ink	10/23/2020	14666	volleyball 2020 shirts	Accounts Payable	\$272.79
Mitchell, Miguelito	10/30/2020	14676	ref fb playoffs SWRR	Accounts Payable	\$86.00
Nebraska Department of Revenue	11/12/2020	30208	Nebraska Department of Revenue	Payroll Liability	\$204.12
Nebraska Dept Of Revenue	11/12/2020	30209	State Withholding - NE	Payroll Liability	\$5,047.00
Nebraska Public Power Distric	11/12/2020	30248	Inv: October Statement	Accounts Payable	\$3,190.37
Nebraska Retirement	11/12/2020	30210	NPERS	Payroll Liability	\$32,132.40
NSAA	11/06/2020	14688	Football Playoffs	Accounts Payable	\$646.70
O'keefe Elevator Company, Inc.	11/12/2020	30249	Inv: 00520822	Accounts Payable	\$340.86
ONE SOURCE	11/12/2020	30250	Inv: 15072007	Accounts Payable	\$25.00
POST PROM	11/03/2020	14682	con pay out	Accounts Payable	\$79.50
PRINCIPAL LIFE GROUP	11/12/2020	30211	Princ Term Life Aft Tax	Payroll Liability	\$60.00
PRINCIPAL LIFE GROUP	11/12/2020	30211	Principal LTDSTD Hourly	Payroll Liability	\$35.60
PRINCIPAL LIFE GROUP	11/12/2020	30211	Principal LTDSTD Supt	Payroll Liability	\$47.25
PRINCIPAL LIFE GROUP	11/12/2020	30211	PrincipalLTDSTD Teacher	Payroll Liability	\$350.00
PYRAMID SCHOOL PRODUCTS	11/12/2020	30251	Inv: ESUCC577038	Accounts Payable	\$1,192.85
Recycling Enterprises	11/12/2020	30252	Inv: 20a3664	Accounts Payable	\$60.00
Ruhl, Anthony	11/06/2020	14689	ref fb playoffs	Accounts Payable	\$84.00
Ruhl, Dale	11/06/2020	14690	ref fb playoffs	Accounts Payable	\$84.00
Ruhl, Robert	11/06/2020	14691	ref fb playoffs	Accounts Payable	\$84.00
Russell Johnson	10/30/2020	14677	ref fb playoffs SWRR	Accounts Payable	\$86.00
Schlegelmilch, Mitchell	11/06/2020	14692	ref fb playoffs	Accounts Payable	\$84.00
School Specialty	11/12/2020	30253	Inv: 208126494566	Accounts Payable	\$27.10
Scott Cafe	10/23/2020	14667	lunch college access	Accounts Payable	\$275.50
SDA Public Schools	10/23/2020	14668	Syracuse JV VB tournament	Accounts Payable	\$110.00
SECURITY BENEFIT	11/12/2020	30212	FSC Sec Corporation	Payroll Liability	\$3,000.00
SECURITY BENEFIT	11/12/2020	30212	FSC Sec Roth	Payroll Liability	\$500.00
SEDIVY, JENNA	10/29/2020	30189	Inv: october reimb	Accounts Payable	\$113.34
SEDIVY, JENNA	10/29/2020	30189	Inv: october reimb part 2	Accounts Payable	\$92.35

Simons, Kady	10/23/2020	14669	ref vb vs j-b	Accounts Payable	\$90.00
Southwest Public School	11/06/2020	14693	Football Playoffs	Accounts Payable	\$592.10
Sprague, Ida Rose	11/12/2020	30254	Inv: reimb, october	Accounts Payable	\$73.90
Sterling Booster Club	11/03/2020	14683	con pay out	Accounts Payable	\$318.00
SYSCO OF LINCOLN	11/12/2020	30255	Inv: 361349908	Accounts Payable	\$1,666.09
SYSCO OF LINCOLN	11/12/2020	30255	Inv: 3613521320	Accounts Payable	\$194.01
SYSCO OF LINCOLN	11/12/2020	30255	Inv: 36135280, 361385281, 361384453	Accounts Payable	\$812.68
SYSCO OF LINCOLN	11/12/2020	30255	Inv: 361360933, 361361891	Accounts Payable	\$502.28
SYSCO OF LINCOLN	11/12/2020	30255	Inv: 361373646	Accounts Payable	\$1,418.16
SYSCO OF LINCOLN	11/12/2020	30255	Inv: 361378603	Accounts Payable	\$928.69
SYSCO OF LINCOLN	11/12/2020	30255	Inv: 361389779	Accounts Payable	\$547.51
T.O. Haas	11/12/2020	30256	Inv: 37-72134	Accounts Payable	\$43.70
Tax Checks	11/12/2020	30206	Federal Withholding	Payroll Liability	\$10,180.27
Tax Checks	11/12/2020	30206	FICA	Payroll Liability	\$21,152.74
Tax Checks	11/12/2020	30206	Medicare	Payroll Liability	\$4,947.04
TeamMates - Sterling	11/03/2020	14684	con pay out	Accounts Payable	\$159.00
Tecumseh Chieftain	11/12/2020	30257	Inv: 3361	Accounts Payable	\$196.08
The Home Depot Pro	11/12/2020	30258	water filter for fountains, boosters will send check to us	Accounts Payable	\$120.16
Thies, Erika	10/23/2020	14670	lines vb vs. j-b	Accounts Payable	\$25.00
Trane US, Inc	11/12/2020	30259	Inv: 311251126	Accounts Payable	\$57.25
U.S. Cellular	11/12/2020	30260	Inv: 0402488934	Accounts Payable	\$42.46
UNITE PRIVATE NETWORKS, LLC	11/12/2020	30261	Inv: si-20-015846	Accounts Payable	\$554.00
United States Postal Service	11/12/2020	30262	Inv: band envelope	Accounts Payable	\$7.75
Village Of Sterling	11/12/2020	30263	Inv: 14158	Accounts Payable	\$172.00
WageWorks, Inc	11/12/2020	30213	Childcare	Payroll Liability	\$1,322.21
WageWorks, Inc	11/12/2020	30213	Medical FLEX	Payroll Liability	\$320.31
WageWorks, Inc	11/12/2020	30264	Inv: 2354350	Accounts Payable	\$50.00
WASTE CONNECTIONS OF NEBRASKA	11/12/2020	30265	Inv: 1715491	Accounts Payable	\$400.00
Waymire Well Drilling, Inc.	11/12/2020	30266	Inv: 20r45q	Accounts Payable	\$91.00
WINDSTREAM COMMUNICATIONS, INC	11/12/2020	30267	Inv: October invoice	Accounts Payable	\$806.28
Wirthele, Cheri J	11/12/2020	30268	Inv: October Cellphone	Accounts Payable	\$25.00
Sub Total					\$542,451.95

pression:

Sterling Public Schools

Check Report

Begin Date: 10/22/2020; End Date: 11/12/2020; Check Type: Accounts Payable and Payroll Liability; Payee: [All]; Bank: [All]; Accounting Cycle: FY20/21; Limit Results PM

Voucher Number	Bank Name	Account Number	Check Number
505	First National Bank	8065050	14658
Vendor	PO Number	Invoice #	Account Code
Appleby, Kelsey		ref vb vs j-b	05-2-02900-352-001
Sub Total			
Voucher Number	Bank Name	Account Number	Check Number
505	First National Bank	8065050	14659
Vendor	PO Number	Invoice #	Account Code
Colby Thies		lines vb vs. j-b	05-2-02900-352-001
Sub Total			
Voucher Number	Bank Name	Account Number	Check Number
505	First National Bank	8065050	14660
Vendor	PO Number	Invoice #	Account Code
Dorchester Public School		Dorchester JH VB tournament	05-2-02900-810-001
Sub Total			
Voucher Number	Bank Name	Account Number	Check Number
505	First National Bank	8065050	14661
Vendor	PO Number	Invoice #	Account Code
Falls City Public School		Falls City VB tournament	05-2-02900-810-001
Sub Total			
Voucher Number	Bank Name	Account Number	Check Number
505	First National Bank	8065050	14662
Vendor	PO Number	Invoice #	Account Code
First Bank of Nebraska		gate con vb vs. j-b	05-2-02900-610-001
Sub Total			
Voucher Number	Bank Name	Account Number	Check Number
505	First National Bank	8065050	14663
Vendor	PO Number	Invoice #	Account Code
FREEMAN PUBLIC SCHOOL		Freeman VB tournament	05-2-02900-810-001
Sub Total			
Voucher Number	Bank Name	Account Number	Check Number
505	First National Bank	8065050	14664

Vendor	PO Number	Invoice #	Account Code
HARCO ATHLETIC RECONDITIONING INC		24731	05-2-02900-610-001
Sub Total			
Voucher Number	Bank Name	Account Number	Check Number
505	First National Bank	8065050	14665
Vendor	PO Number	Invoice #	Account Code
Mahaska-Pepsi		3356465	05-2-02900-610-000
Sub Total			
Voucher Number	Bank Name	Account Number	Check Number
505	First National Bank	8065050	14666
Vendor	PO Number	Invoice #	Account Code
Merz Ink		001144	05-2-02900-610-001
Sub Total			
Voucher Number	Bank Name	Account Number	Check Number
505	First National Bank	8065050	14667
Vendor	PO Number	Invoice #	Account Code
Scott Cafe		20021130	05-2-02900-610-001
Sub Total			
Voucher Number	Bank Name	Account Number	Check Number
505	First National Bank	8065050	14668
Vendor	PO Number	Invoice #	Account Code
SDA Public Schools		2020 JV VB tournament	05-2-02900-810-001
Sub Total			
Voucher Number	Bank Name	Account Number	Check Number
505	First National Bank	8065050	14669
Vendor	PO Number	Invoice #	Account Code
Simons, Kady		ref vb vs j-b	05-2-02900-352-001
Sub Total			
Voucher Number	Bank Name	Account Number	Check Number
505	First National Bank	8065050	14670
Vendor	PO Number	Invoice #	Account Code
Thies, Erika		lines vb vs. j-b	05-2-02900-352-001
Sub Total			
Voucher Number	Bank Name	Account Number	Check Number
506	First National Bank	8065050	14671
Vendor	PO Number	Invoice #	Account Code
Club's Choice		Band/Choir Fundraiser	05-2-02900-610-001

Sub Total			
Voucher Number 508	Bank Name First National Bank	Account Number 8065050	Check Number 14672
Vendor Clark, Lance	PO Number	Invoice # ref fb playoffs SWRR	Account Code 05-2-02900-352-001
Sub Total			
Voucher Number 508	Bank Name First National Bank	Account Number 8065050	Check Number 14673
Vendor First Bank of Nebraska	PO Number	Invoice # gate con fb playoff SWRR	Account Code 05-2-02900-610-001
Sub Total			
Voucher Number 508	Bank Name First National Bank	Account Number 8065050	Check Number 14674
Vendor Hall, Nathan	PO Number	Invoice # ref fb playoffs SWRR	Account Code 05-2-02900-352-001
Sub Total			
Voucher Number 508	Bank Name First National Bank	Account Number 8065050	Check Number 14675
Vendor Harman, Mark	PO Number	Invoice # ref fb playoffs SWRR	Account Code 05-2-02900-352-001
Sub Total			
Voucher Number 508	Bank Name First National Bank	Account Number 8065050	Check Number 14676
Vendor Mitchell, Miguelito	PO Number	Invoice # ref fb playoffs SWRR	Account Code 05-2-02900-352-001
Sub Total			
Voucher Number 508	Bank Name First National Bank	Account Number 8065050	Check Number 14677
Vendor Russell Johnson	PO Number	Invoice # ref fb playoffs SWRR	Account Code 05-2-02900-352-001
Sub Total			
Voucher Number 509	Bank Name First National Bank	Account Number 8065050	Check Number 14678
Vendor Amazon Capital Services	PO Number	Invoice # 113P-7T11-N6YR	Account Code 05-2-02900-610-001
Sub Total			

Voucher Number	Bank Name	Account Number	Check Number
509	First National Bank	8065050	14679
Vendor	PO Number	Invoice #	Account Code
CORPORATE PAYMENT SYSTEMS		Sept Oct credit card	05-2-02900-610-001
CORPORATE PAYMENT SYSTEMS		Sept Oct credit card	05-2-02900-610-001
CORPORATE PAYMENT SYSTEMS		Sept Oct credit card	05-2-02900-610-001
CORPORATE PAYMENT SYSTEMS		Sept Oct credit card	05-2-02900-610-001
CORPORATE PAYMENT SYSTEMS		Sept Oct credit card	05-2-02900-810-001
Sub Total			
Voucher Number	Bank Name	Account Number	Check Number
509	First National Bank	8065050	14680
Vendor	PO Number	Invoice #	Account Code
JET STOP INC.		00016885	05-2-02900-610-001
Sub Total			
Voucher Number	Bank Name	Account Number	Check Number
509	First National Bank	8065050	14681
Vendor	PO Number	Invoice #	Account Code
Mahaska-Pepsi		3356624, 3356549	05-2-02900-610-001
Sub Total			
Voucher Number	Bank Name	Account Number	Check Number
509	First National Bank	8065050	14682
Vendor	PO Number	Invoice #	Account Code
POST PROM		con pay out	05-2-02900-610-001
Sub Total			
Voucher Number	Bank Name	Account Number	Check Number
509	First National Bank	8065050	14683
Vendor	PO Number	Invoice #	Account Code
Sterling Booster Club		con pay out	05-2-02900-610-001
Sub Total			
Voucher Number	Bank Name	Account Number	Check Number
509	First National Bank	8065050	14684
Vendor	PO Number	Invoice #	Account Code
TeamMates - Sterling		con pay out	05-2-02900-610-001
Sub Total			
Voucher Number	Bank Name	Account Number	Check Number
510	First National Bank	8065050	14685
Vendor	PO Number	Invoice #	Account Code
First Bank of Nebraska		con, gate fb playoffs	05-2-02900-610-000

First Bank of Nebraska		con, gate fb playoffs	05-2-02900-610-000
Sub Total			
Voucher Number 511	Bank Name First National Bank	Account Number 8065050	Check Number 14686
Vendor Axline, Dustin	PO Number	Invoice # ref fb playoffs	Account Code 05-2-02900-352-001
Sub Total			
Voucher Number 511	Bank Name First National Bank	Account Number 8065050	Check Number 14687
Vendor Cash-wa Distribution	PO Number	Invoice # 12632989	Account Code 05-2-02900-610-000
Sub Total			
Voucher Number 511	Bank Name First National Bank	Account Number 8065050	Check Number 14688
Vendor NSAA	PO Number	Invoice # Football Playoffs	Account Code 05-2-02900-610-000
Sub Total			
Voucher Number 511	Bank Name First National Bank	Account Number 8065050	Check Number 14689
Vendor Ruhl, Anthony	PO Number	Invoice # ref fb playoffs	Account Code 05-2-02900-352-001
Sub Total			
Voucher Number 511	Bank Name First National Bank	Account Number 8065050	Check Number 14690
Vendor Ruhl, Dale	PO Number	Invoice # ref fb playoffs	Account Code 05-2-02900-352-001
Sub Total			
Voucher Number 511	Bank Name First National Bank	Account Number 8065050	Check Number 14691
Vendor Ruhl, Robert	PO Number	Invoice # ref fb playoffs	Account Code 05-2-02900-352-001
Sub Total			
Voucher Number 511	Bank Name First National Bank	Account Number 8065050	Check Number 14692
Vendor Schlegelmilch, Mitchell	PO Number	Invoice # ref fb playoffs	Account Code 05-2-02900-352-001
Sub Total			

Voucher Number	Bank Name	Account Number	Check Number
511	First National Bank	8065050	14693
Vendor	PO Number	Invoice #	Account Code
Southwest Public School		Football Playoffs	05-2-02900-610-000
Sub Total			
Voucher Number	Bank Name	Account Number	Check Number
Preschool October	First National Bank	8059655	30189
Vendor	PO Number	Invoice #	Account Code
SEDIVY, JENNA		october reimb	01-2-01190-610-002
SEDIVY, JENNA		october reimb part 2	01-2-01190-610-002
Sub Total			
Voucher Number	Bank Name	Account Number	Check Number
October/November Bills	First National Bank	8059655	30214
Vendor	PO Number	Invoice #	Account Code
Acco Brands		4712981633, 4713671613	01-2-01100-610-000
Sub Total			
Voucher Number	Bank Name	Account Number	Check Number
October/November Bills	First National Bank	8059655	30215
Vendor	PO Number	Invoice #	Account Code
Al's Johns		37516	01-2-02610-441-000
Sub Total			
Voucher Number	Bank Name	Account Number	Check Number
October/November Bills	First National Bank	8059655	30216
Vendor	PO Number	Invoice #	Account Code
Allen, Adrian W		October cellphone	01-2-02320-382-000
Sub Total			
Voucher Number	Bank Name	Account Number	Check Number
October/November Bills	First National Bank	8059655	30217
Vendor	PO Number	Invoice #	Account Code
Amazon Capital Services		11w1-gttf-76jf	01-2-01100-610-000
Amazon Capital Services		ijnr-gwl1-4jvh	01-2-01100-610-000
Amazon Capital Services		itj4-dlcj-3n4c	01-2-01100-640-000
Amazon Capital Services		1vgj-ffwq-hfhj	01-2-01190-610-000
Amazon Capital Services		1kc1-4pm7-6t4m	01-2-02220-640-001
Amazon Capital Services		1vx7-q7lq-74fm	01-2-02220-640-001
Amazon Capital Services		1xcl-gc46-3pdh	01-2-02220-640-002
Amazon Capital Services		1r9w-m1v6-nrpk	01-2-02580-650-000
Amazon Capital Services		1vx7-q7lq-w9yq	01-2-02580-650-000

Amazon Capital Services		1md3-9qn7-ji6m	01-2-02580-650-000
Amazon Capital Services		ifh9-74pn-6pjj	01-2-02610-110-000
Amazon Capital Services	21-0008	1y49-hpvx-l140	01-2-02580-650-000
Amazon Capital Services	21-0013	1jrr-kryt-whp6	01-2-01100-650-002
Sub Total			
Voucher Number	Bank Name	Account Number	Check Number
October/November Bills	First National Bank	8059655	30218
Vendor	PO Number	Invoice #	Account Code
Bernard Food Ind. Inc		00861932	06-2-03100-630-000
Sub Total			
Voucher Number	Bank Name	Account Number	Check Number
October/November Bills	First National Bank	8059655	30219
Vendor	PO Number	Invoice #	Account Code
Boden, Ronald R		October cellphone	01-2-02710-382-000
Sub Total			
Voucher Number	Bank Name	Account Number	Check Number
October/November Bills	First National Bank	8059655	30220
Vendor	PO Number	Invoice #	Account Code
BOK FINANCIAL		jcsdgorb2012-BOND	07-2-05000-831-000
BOK FINANCIAL		jcsdgorb2012-BOND	07-2-05000-832-000
BOK FINANCIAL		jcsdgorb2012-BOND	07-2-05000-890-000
BOK FINANCIAL		jcsd33ltos14-QCPUF	09-2-05000-831-000
BOK FINANCIAL		jcsd33ltos14-QCPUF	09-2-05000-832-000
BOK FINANCIAL		jcsd33ltos14-QCPUF	09-2-05000-890-000
Sub Total			
Voucher Number	Bank Name	Account Number	Check Number
October/November Bills	First National Bank	8059655	30221
Vendor	PO Number	Invoice #	Account Code
Boldt, Luke M		October cellphone	01-2-02710-382-000
Sub Total			
Voucher Number	Bank Name	Account Number	Check Number
October/November Bills	First National Bank	8059655	30222
Vendor	PO Number	Invoice #	Account Code
Boslau, Dennis R		October cellphone	01-2-02710-382-000
Sub Total			
Voucher Number	Bank Name	Account Number	Check Number
October/November Bills	First National Bank	8059655	30223
Vendor	PO Number	Invoice #	Account Code

CAPITAL BUSINESS SYSTEMS, INC		28020182	01-2-02530-550-000
Sub Total			
Voucher Number October/November Bills	Bank Name First National Bank	Account Number 8059655	Check Number 30224
Vendor Carpenter, Jay N	PO Number	Invoice # October Cellphone	Account Code 01-2-02710-382-000
Sub Total			
Voucher Number October/November Bills	Bank Name First National Bank	Account Number 8059655	Check Number 30225
Vendor Cash-wa Distribution	PO Number	Invoice # 12668058	Account Code 06-1-03100-630-000
Cash-wa Distribution		12659577	06-2-03100-630-000
Cash-wa Distribution		12659577	06-2-03100-630-000
Sub Total			
Voucher Number October/November Bills	Bank Name First National Bank	Account Number 8059655	Check Number 30226
Vendor CULLIGAN OF LINCOLN	PO Number	Invoice # 201517-kitchen	Account Code 01-2-02610-410-000
CULLIGAN OF LINCOLN		85659	01-2-02610-410-000
CULLIGAN OF LINCOLN		85660	01-2-02610-410-000
CULLIGAN OF LINCOLN		85661	01-2-02610-410-000
Sub Total			
Voucher Number October/November Bills	Bank Name First National Bank	Account Number 8059655	Check Number 30227
Vendor DAVENPORT, JACOB M	PO Number	Invoice # October Cellphone	Account Code 01-2-02410-382-000
Sub Total			
Voucher Number October/November Bills	Bank Name First National Bank	Account Number 8059655	Check Number 30228
Vendor Dietze Music House	PO Number	Invoice # TA7226	Account Code 01-2-01100-610-001
Sub Total			
Voucher Number October/November Bills	Bank Name First National Bank	Account Number 8059655	Check Number 30229
Vendor Diversified Drug Testing	PO Number	Invoice # 2021 membership dues	Account Code 01-2-02570-810-000
Sub Total			

Voucher Number	Bank Name	Account Number	Check Number
October/November Bills	First National Bank	8059655	30230
Vendor	PO Number	Invoice #	Account Code
EGAN SUPPLY CO		320012A, 327704	01-2-02610-610-000
EGAN SUPPLY CO		320012A, 327704	01-2-02610-610-000
EGAN SUPPLY CO		325841A	01-2-02610-610-000
EGAN SUPPLY CO		327642	01-2-02610-610-000
Sub Total			
Voucher Number	Bank Name	Account Number	Check Number
October/November Bills	First National Bank	8059655	30231
Vendor	PO Number	Invoice #	Account Code
ESU #4		October Billing date	01-2-01200-591-001
ESU #4		October Billing date	01-2-01200-591-002
ESU #4		October Billing date	01-2-02141-591-001
ESU #4		October Billing date	01-2-02141-591-002
ESU #4		October Billing date	01-2-02151-591-001
ESU #4		October Billing date	01-2-02151-591-001
ESU #4		October Billing date	01-2-02151-591-002
ESU #4		October Billing date	01-2-02151-591-002
ESU #4		October Billing date	01-2-02151-591-002
ESU #4		9417-McCormick	01-2-02230-591-000
ESU #4		October Billing date	01-2-06408-591-002
ESU #4		October Billing date	01-2-06408-591-002
ESU #4		October Billing date	01-2-06408-591-002
ESU #4		October Billing date	01-2-06408-591-002
Sub Total			
Voucher Number	Bank Name	Account Number	Check Number
October/November Bills	First National Bank	8059655	30232
Vendor	PO Number	Invoice #	Account Code
ESU #6		14334	01-2-02230-643-000
Sub Total			
Voucher Number	Bank Name	Account Number	Check Number
October/November Bills	First National Bank	8059655	30233
Vendor	PO Number	Invoice #	Account Code
FILTER SHOP		145514	01-2-02610-610-000
FILTER SHOP		146843	01-2-02610-610-000
Sub Total			
Voucher Number	Bank Name	Account Number	Check Number
October/November Bills	First National Bank	8059655	30234
Vendor	PO Number	Invoice #	Account Code

FUN & FUNCTION	21-0012	466717	01-2-02181-591-002
Sub Total			
Voucher Number October/November Bills	Bank Name First National Bank	Account Number 8059655	Check Number 30235
Vendor Hancock Lumber, LLC	PO Number	Invoice # 000602	Account Code 01-2-02610-610-000
Hancock Lumber, LLC		00602	01-2-02610-610-000
Sub Total			
Voucher Number October/November Bills	Bank Name First National Bank	Account Number 8059655	Check Number 30236
Vendor HARRIS SCHOOL SOLUTIONS	PO Number	Invoice # XT00167933	Account Code 01-2-02580-643-000
Sub Total			
Voucher Number October/November Bills	Bank Name First National Bank	Account Number 8059655	Check Number 30237
Vendor Heusman, Brent J	PO Number	Invoice # October cellphone	Account Code 01-2-02710-382-000
Sub Total			
Voucher Number October/November Bills	Bank Name First National Bank	Account Number 8059655	Check Number 30238
Vendor HILAND DAIRY	PO Number	Invoice # October Invoices	Account Code 06-2-03100-630-000
HILAND DAIRY		October Invoices	06-2-03100-630-000
HILAND DAIRY		October Invoices	06-2-03100-630-000
HILAND DAIRY		October Invoices	06-2-03100-630-000
HILAND DAIRY		October Invoices	06-2-03100-630-000
HILAND DAIRY		October Invoices	06-2-03100-630-000
HILAND DAIRY		October Invoices	06-2-03100-630-000
HILAND DAIRY		October Invoices	06-2-03100-630-000
HILAND DAIRY		October Invoices	06-2-03100-630-000
HILAND DAIRY		October Invoices	06-2-03100-630-000
HILAND DAIRY		October Invoices	06-2-03100-630-000
Sub Total			
Voucher Number October/November Bills	Bank Name First National Bank	Account Number 8059655	Check Number 30239
Vendor Innovative	PO Number	Invoice # teacher supplies 19/20	Account Code 01-2-01100-610-000
Innovative		teacher supplies 19/20	01-2-01100-610-000
Innovative		teacher supplies 19/20	01-2-01100-610-000

Innovative		teacher supplies 19/20	01-2-01100-610-000
Innovative		teacher supplies 19/20	01-2-01100-610-000
Innovative		teacher supplies 19/20	01-2-01100-610-000
Innovative		teacher supplies 19/20	01-2-01100-610-000
Innovative		teacher supplies 19/20	01-2-01100-610-000
Innovative		teacher supplies 19/20	01-2-01100-610-000
Sub Total			
Voucher Number	Bank Name	Account Number	Check Number
October/November Bills	First National Bank	8059655	30240
Vendor	PO Number	Invoice #	Account Code
JET STOP INC.		4556	01-2-02630-626-000
JET STOP INC.		4556	01-2-02710-626-000
JET STOP INC.		4556	01-2-02712-626-000
Sub Total			
Voucher Number	Bank Name	Account Number	Check Number
October/November Bills	First National Bank	8059655	30241
Vendor	PO Number	Invoice #	Account Code
Johnson County Hospital		OT October Bill	01-2-02141-334-000
Johnson County Hospital		PT October bill	01-2-02141-334-002
Johnson County Hospital		OT October Bill	01-2-02161-591-002
Johnson County Hospital		OT October Bill	01-2-02162-591-002
Johnson County Hospital		OT October Bill	01-2-02162-591-002
Johnson County Hospital		PT October bill	01-2-02171-591-002
Johnson County Hospital		Jay Carpenter physical	01-2-02710-340-000
Sub Total			
Voucher Number	Bank Name	Account Number	Check Number
October/November Bills	First National Bank	8059655	30242
Vendor	PO Number	Invoice #	Account Code
KSB SCHOOL LAW		9098	01-2-02330-317-000
Sub Total			
Voucher Number	Bank Name	Account Number	Check Number
October/November Bills	First National Bank	8059655	30243
Vendor	PO Number	Invoice #	Account Code
KUDU LAWN CARE		10102220	01-2-02630-431-000
Sub Total			
Voucher Number	Bank Name	Account Number	Check Number
October/November Bills	First National Bank	8059655	30244
Vendor	PO Number	Invoice #	Account Code
Life Track Services	21-0010	29275	01-2-02120-565-001

Sub Total			
Voucher Number October/November Bills	Bank Name First National Bank	Account Number 8059655	Check Number 30245
Vendor MARSHALL KATIE B	PO Number	Invoice # reimb.	Account Code 01-2-01190-610-002
Sub Total			
Voucher Number October/November Bills	Bank Name First National Bank	Account Number 8059655	Check Number 30246
Vendor Matheson Trigas DBA Linweld	PO Number	Invoice # 51706741	Account Code 01-2-02610-610-000
Sub Total			
Voucher Number October/November Bills	Bank Name First National Bank	Account Number 8059655	Check Number 30247
Vendor Menards	PO Number	Invoice # 47644	Account Code 01-2-02610-610-000
Sub Total			
Voucher Number October/November Bills	Bank Name First National Bank	Account Number 8059655	Check Number 30248
Vendor Nebraska Public Power Distric	PO Number	Invoice # October Statement	Account Code 01-2-02610-410-000
Sub Total			
Voucher Number October/November Bills	Bank Name First National Bank	Account Number 8059655	Check Number 30249
Vendor O'keefe Elevator Company, Inc.	PO Number	Invoice # 00520822	Account Code 01-2-02620-431-000
Sub Total			
Voucher Number October/November Bills	Bank Name First National Bank	Account Number 8059655	Check Number 30250
Vendor ONE SOURCE	PO Number	Invoice # 15072007	Account Code 01-2-02320-310-000
Sub Total			
Voucher Number October/November Bills	Bank Name First National Bank	Account Number 8059655	Check Number 30251
Vendor PYRAMID SCHOOL PRODUCTS	PO Number	Invoice # ESUCC577038	Account Code 01-2-01100-610-000
Sub Total			

Voucher Number	Bank Name	Account Number	Check Number
October/November Bills	First National Bank	8059655	30252
Vendor	PO Number	Invoice #	Account Code
Recycling Enterprises		20a3664	01-2-02610-410-000
Sub Total			
Voucher Number	Bank Name	Account Number	Check Number
October/November Bills	First National Bank	8059655	30253
Vendor	PO Number	Invoice #	Account Code
School Specialty		208126494566	01-2-01100-610-002
Sub Total			
Voucher Number	Bank Name	Account Number	Check Number
October/November Bills	First National Bank	8059655	30254
Vendor	PO Number	Invoice #	Account Code
Sprague, Ida Rose		reimb, october	01-2-01100-610-000
Sub Total			
Voucher Number	Bank Name	Account Number	Check Number
October/November Bills	First National Bank	8059655	30255
Vendor	PO Number	Invoice #	Account Code
SYSCO OF LINCOLN		361389779	06-2-03100-610-000
SYSCO OF LINCOLN		361349908	06-2-03100-630-000
SYSCO OF LINCOLN		3613521320	06-2-03100-630-000
SYSCO OF LINCOLN		36135280, 361385281, 361384453	06-2-03100-630-000
SYSCO OF LINCOLN		361360933, 361361891	06-2-03100-630-000
SYSCO OF LINCOLN		361373646	06-2-03100-630-000
SYSCO OF LINCOLN		361378603	06-2-03100-630-000
SYSCO OF LINCOLN		361389779	06-2-03100-630-000
Sub Total			
Voucher Number	Bank Name	Account Number	Check Number
October/November Bills	First National Bank	8059655	30256
Vendor	PO Number	Invoice #	Account Code
T.O. Haas		37-72134	01-2-02730-431-000
Sub Total			
Voucher Number	Bank Name	Account Number	Check Number
October/November Bills	First National Bank	8059655	30257
Vendor	PO Number	Invoice #	Account Code
Tecumseh Chieftain		3361	01-2-02310-540-000
Sub Total			
Voucher Number	Bank Name	Account Number	Check Number

October/November Bills	First National Bank	8059655	30258
Vendor	PO Number	Invoice #	Account Code
The Home Depot Pro		582546107	01-2-01100-610-000
Sub Total			
Voucher Number	Bank Name	Account Number	Check Number
October/November Bills	First National Bank	8059655	30259
Vendor	PO Number	Invoice #	Account Code
Trane US, Inc		311251126	01-2-02620-430-000
Sub Total			
Voucher Number	Bank Name	Account Number	Check Number
October/November Bills	First National Bank	8059655	30260
Vendor	PO Number	Invoice #	Account Code
U.S. Cellular		0402488934	01-2-02610-382-000
Sub Total			
Voucher Number	Bank Name	Account Number	Check Number
October/November Bills	First National Bank	8059655	30261
Vendor	PO Number	Invoice #	Account Code
UNITE PRIVATE NETWORKS, LLC		si-20-015846	01-2-02230-530-000
Sub Total			
Voucher Number	Bank Name	Account Number	Check Number
October/November Bills	First National Bank	8059655	30262
Vendor	PO Number	Invoice #	Account Code
United States Postal Service		band envelope	01-2-02310-531-000
Sub Total			
Voucher Number	Bank Name	Account Number	Check Number
October/November Bills	First National Bank	8059655	30263
Vendor	PO Number	Invoice #	Account Code
Village Of Sterling		14158	01-2-02610-410-000
Sub Total			
Voucher Number	Bank Name	Account Number	Check Number
October/November Bills	First National Bank	8059655	30264
Vendor	PO Number	Invoice #	Account Code
WageWorks, Inc		2354350	01-2-02900-810-000
Sub Total			
Voucher Number	Bank Name	Account Number	Check Number
October/November Bills	First National Bank	8059655	30265
Vendor	PO Number	Invoice #	Account Code

WASTE CONNECTIONS OF NEBRASKA		1715491	01-2-02610-410-000
Sub Total			
Voucher Number October/November Bills	Bank Name First National Bank	Account Number 8059655	Check Number 30266
Vendor Waymire Well Drilling, Inc.	PO Number	Invoice # 20r45q	Account Code 01-2-02610-431-000
Sub Total			
Voucher Number October/November Bills	Bank Name First National Bank	Account Number 8059655	Check Number 30267
Vendor WINDSTREAM COMMUNICATIONS, INC	PO Number	Invoice # October invoice	Account Code 01-2-02610-382-000
Sub Total			
Voucher Number October/November Bills	Bank Name First National Bank	Account Number 8059655	Check Number 30268
Vendor Wirthele, Cheri J	PO Number	Invoice # October Cellphone	Account Code 01-2-01200-382-000
Sub Total			
Grand Total			

s to This Cycle: Yes; Account Expression: [All]; Show Detail by Voucher: Yes; Created On: 11/12/2020 12:27:45

Payee	Amount	Type
Appleby, Kelsey	\$90.00	Accounts Payable
Description	Issue Date	Amount
ref vb vs j-b		\$90.00
		\$90.00
Payee	Amount	Type
Colby Thies	\$25.00	Accounts Payable
Description	Issue Date	Amount
lines vb vs. j-b		\$25.00
		\$25.00
Payee	Amount	Type
Dorchester Public School	\$75.00	Accounts Payable
Description	Issue Date	Amount
Dorchester JH VB tournament		\$75.00
		\$75.00
Payee	Amount	Type
Falls City Public School	\$110.00	Accounts Payable
Description	Issue Date	Amount
Falls City VB tournament		\$110.00
		\$110.00
Payee	Amount	Type
First Bank of Nebraska	\$460.00	Accounts Payable
Description	Issue Date	Amount
gate con vb vs. j-b		\$460.00
		\$460.00
Payee	Amount	Type
FREEMAN PUBLIC SCHOOL	\$150.00	Accounts Payable
Description	Issue Date	Amount
Freeman VB tournament		\$150.00
		\$150.00
Payee	Amount	Type
HARCO ATHLETIC RECONDITIONING INC	\$1,354.00	Accounts Payable

Description	Issue Date	Amount
football helmet reconditioning		\$1,354.00
		\$1,354.00
Payee	Amount	Type
Mahaska-Pepsi	\$320.00	Accounts Payable
Description	Issue Date	Amount
concessions		\$320.00
		\$320.00
Payee	Amount	Type
Merz Ink	\$272.79	Accounts Payable
Description	Issue Date	Amount
volleyball 2020 shirts		\$272.79
		\$272.79
Payee	Amount	Type
Scott Cafe	\$275.50	Accounts Payable
Description	Issue Date	Amount
lunch college access		\$275.50
		\$275.50
Payee	Amount	Type
SDA Public Schools	\$110.00	Accounts Payable
Description	Issue Date	Amount
Syracuse JV VB tournament		\$110.00
		\$110.00
Payee	Amount	Type
Simons, Kady	\$90.00	Accounts Payable
Description	Issue Date	Amount
ref vb vs j-b		\$90.00
		\$90.00
Payee	Amount	Type
Thies, Erika	\$25.00	Accounts Payable
Description	Issue Date	Amount
lines vb vs. j-b		\$25.00
		\$25.00
Payee	Amount	Type
Club's Choice	\$3,683.00	Accounts Payable
Description	Issue Date	Amount
Band/Choir Fundraiser		\$3,683.00

		\$3,683.00
Payee	Amount	Type
Clark, Lance	\$86.00	Accounts Payable
Description	Issue Date	Amount
ref fb playoffs SWRR		\$86.00
		\$86.00
Payee	Amount	Type
First Bank of Nebraska	\$810.00	Accounts Payable
Description	Issue Date	Amount
gate con fb playoff SWRR		\$810.00
		\$810.00
Payee	Amount	Type
Hall, Nathan	\$86.00	Accounts Payable
Description	Issue Date	Amount
ref fb playoffs SWRR		\$86.00
		\$86.00
Payee	Amount	Type
Harman, Mark	\$86.00	Accounts Payable
Description	Issue Date	Amount
ref fb playoffs SWRR		\$86.00
		\$86.00
Payee	Amount	Type
Mitchell, Miguelito	\$86.00	Accounts Payable
Description	Issue Date	Amount
ref fb playoffs SWRR		\$86.00
		\$86.00
Payee	Amount	Type
Russell Johnson	\$86.00	Accounts Payable
Description	Issue Date	Amount
ref fb playoffs SWRR		\$86.00
		\$86.00
Payee	Amount	Type
Amazon Capital Services	\$111.88	Accounts Payable
Description	Issue Date	Amount
FFA fruit sales rewards		\$111.88
		\$111.88

Payee	Amount	Type
CORPORATE PAYMENT SYSTEMS	\$2,285.54	Accounts Payable
Description	Issue Date	Amount
Homecoming Prom crowns tiaras Shindigz		\$77.20
Impact Applications - athletics		\$435.00
Krispy Kreme class of 2023		\$645.62
Krispy Kreme College Access		\$28.72
Volleyball, Football Hudl		\$1,099.00
		\$2,285.54
Payee	Amount	Type
JET STOP INC.	\$48.87	Accounts Payable
Description	Issue Date	Amount
college access		\$48.87
		\$48.87
Payee	Amount	Type
Mahaska-Pepsi	\$826.00	Accounts Payable
Description	Issue Date	Amount
concessions		\$826.00
		\$826.00
Payee	Amount	Type
POST PROM	\$79.50	Accounts Payable
Description	Issue Date	Amount
con pay out		\$79.50
		\$79.50
Payee	Amount	Type
Sterling Booster Club	\$318.00	Accounts Payable
Description	Issue Date	Amount
con pay out		\$318.00
		\$318.00
Payee	Amount	Type
TeamMates - Sterling	\$159.00	Accounts Payable
Description	Issue Date	Amount
con pay out		\$159.00
		\$159.00
Payee	Amount	Type
First Bank of Nebraska	\$940.00	Accounts Payable
Description	Issue Date	Amount
con fb playoffs		\$190.00

gate fb playoffs		\$750.00
		\$940.00
Payee	Amount	Type
Axline, Dustin	\$84.00	Accounts Payable
Description	Issue Date	Amount
ref fb playoffs		\$84.00
		\$84.00
Payee	Amount	Type
Cash-wa Distribution	\$537.68	Accounts Payable
Description	Issue Date	Amount
concessions		\$537.68
		\$537.68
Payee	Amount	Type
NSAA	\$646.70	Accounts Payable
Description	Issue Date	Amount
Football Playoffs		\$646.70
		\$646.70
Payee	Amount	Type
Ruhl, Anthony	\$84.00	Accounts Payable
Description	Issue Date	Amount
ref fb playoffs		\$84.00
		\$84.00
Payee	Amount	Type
Ruhl, Dale	\$84.00	Accounts Payable
Description	Issue Date	Amount
ref fb playoffs		\$84.00
		\$84.00
Payee	Amount	Type
Ruhl, Robert	\$84.00	Accounts Payable
Description	Issue Date	Amount
ref fb playoffs		\$84.00
		\$84.00
Payee	Amount	Type
Schlegelmilch, Mitchell	\$84.00	Accounts Payable
Description	Issue Date	Amount
ref fb playoffs		\$84.00
		\$84.00

Payee	Amount	Type
Southwest Public School	\$592.10	Accounts Payable
Description	Issue Date	Amount
Football Playoffs		\$592.10
		\$592.10
Payee	Amount	Type
SEDIVY, JENNA	\$205.69	Accounts Payable
Description	Issue Date	Amount
		\$113.34
		\$92.35
		\$205.69
Payee	Amount	Type
Acco Brands	\$37.50	Accounts Payable
Description	Issue Date	Amount
		\$37.50
		\$37.50
Payee	Amount	Type
Al's Johns	\$121.33	Accounts Payable
Description	Issue Date	Amount
		\$121.33
		\$121.33
Payee	Amount	Type
Allen, Adrian W	\$50.00	Accounts Payable
Description	Issue Date	Amount
		\$50.00
		\$50.00
Payee	Amount	Type
Amazon Capital Services	\$1,570.28	Accounts Payable
Description	Issue Date	Amount
		\$21.90
		\$37.89
		\$24.34
		\$413.81
		\$22.01
books		\$88.52
		\$112.59
		\$239.94
		\$12.99

ipod touch 7 case		\$21.98
bleach, supplies		\$223.15
Wall Mount Rack Enclosure Server Cabinet - Weight Room Switch and fiber	10/09/2020	\$211.27
Mimio Projector Bulb Elementary	11/02/2020	\$139.89
		\$1,570.28

Payee	Amount	Type
Bernard Food Ind. Inc	\$220.32	Accounts Payable

Description	Issue Date	Amount
mexican lasagna and gummy worms		\$220.32
		\$220.32

Payee	Amount	Type
Boden, Ronald R	\$25.00	Accounts Payable

Description	Issue Date	Amount
		\$25.00
		\$25.00

Payee	Amount	Type
BOK FINANCIAL	\$228,918.75	Accounts Payable

Description	Issue Date	Amount
Principal Due		\$150,000.00
Interest		\$9,931.25
Agent Fee		\$200.00
Principal Due		\$65,000.00
Interest Due		\$3,587.50
Agent Fee		\$200.00
		\$228,918.75

Payee	Amount	Type
Boldt, Luke M	\$25.00	Accounts Payable

Description	Issue Date	Amount
		\$25.00
		\$25.00

Payee	Amount	Type
Boslau, Dennis R	\$25.00	Accounts Payable

Description	Issue Date	Amount
		\$25.00
		\$25.00

Payee	Amount	Type
CAPITAL BUSINESS SYSTEMS, INC	\$2,557.11	Accounts Payable

Description	Issue Date	Amount
--------------------	-------------------	---------------

		\$2,557.11
		\$2,557.11
Payee	Amount	Type
Carpenter, Jay N	\$12.50	Accounts Payable
Description	Issue Date	Amount
		\$12.50
		\$12.50
Payee	Amount	Type
Cash-wa Distribution	\$814.44	Accounts Payable
Description	Issue Date	Amount
		\$781.49
		\$43.10
scholar dollars		(\$10.15)
		\$814.44
Payee	Amount	Type
CULLIGAN OF LINCOLN	\$528.19	Accounts Payable
Description	Issue Date	Amount
		\$342.25
		\$144.87
		\$13.87
		\$27.20
		\$528.19
Payee	Amount	Type
DAVENPORT, JACOB M	\$50.00	Accounts Payable
Description	Issue Date	Amount
		\$50.00
		\$50.00
Payee	Amount	Type
Dietze Music House	\$9.90	Accounts Payable
Description	Issue Date	Amount
		\$9.90
		\$9.90
Payee	Amount	Type
Diversified Drug Testing	\$50.00	Accounts Payable
Description	Issue Date	Amount
		\$50.00
		\$50.00

Payee	Amount	Type
EGAN SUPPLY CO	\$1,137.53	Accounts Payable
Description	Issue Date	Amount
		\$209.32
carpet shampoo		\$48.56
latex gloves		\$116.50
water softner pellets-pallet		\$763.15
		\$1,137.53
Payee	Amount	Type
ESU #4	\$35,643.33	Accounts Payable
Description	Issue Date	Amount
special ed		\$1,333.00
special ed director elem		\$1,333.00
psychology sec		\$2,333.25
psychology elem		\$2,333.25
audiology sec		\$249.75
deaf educator secondary		\$111.00
audiology elem		\$249.75
speech pathology elem		\$4,704.00
speech pathology secondary		\$672.00
Jake McCormick first half of contract		\$20,000.00
audiology		\$55.50
early childhood consultant		\$258.33
special education director		\$666.50
speech pathology		\$1,344.00
		\$35,643.33
Payee	Amount	Type
ESU #6	\$77.50	Accounts Payable
Description	Issue Date	Amount
		\$77.50
		\$77.50
Payee	Amount	Type
FILTER SHOP	\$664.21	Accounts Payable
Description	Issue Date	Amount
		\$274.24
		\$389.97
		\$664.21
Payee	Amount	Type
FUN & FUNCTION	\$14.90	Accounts Payable
Description	Issue Date	Amount

raised line paper for Cooper Pella - vision	10/29/2020	\$14.90
		\$14.90
Payee	Amount	Type
Hancock Lumber, LLC	\$51.96	Accounts Payable
Description	Issue Date	Amount
		\$25.98
		\$25.98
		\$51.96
Payee	Amount	Type
HARRIS SCHOOL SOLUTIONS	\$209.20	Accounts Payable
Description	Issue Date	Amount
Tax forms		\$209.20
		\$209.20
Payee	Amount	Type
Heusman, Brent J	\$25.00	Accounts Payable
Description	Issue Date	Amount
		\$25.00
		\$25.00
Payee	Amount	Type
HILAND DAIRY	\$1,604.45	Accounts Payable
Description	Issue Date	Amount
950668		\$156.82
950708		(\$11.00)
950709		\$192.58
950758		\$157.50
950796		(\$38.93)
950797		\$279.21
950840		\$139.71
950877		\$245.45
950966		(\$6.26)
950967		\$279.94
951015		\$209.43
		\$1,604.45
Payee	Amount	Type
Innovative	\$2,100.53	Accounts Payable
Description	Issue Date	Amount
3016267		\$1,501.92
3017710		\$148.00
3025163		\$274.39

3030054		\$138.42
3034159		\$46.86
3068142		\$37.87
3082280		\$13.09
3117479		\$13.09
scn-100751		(\$73.11)
		\$2,100.53

Payee	Amount	Type
JET STOP INC.	\$1,419.73	Accounts Payable

Description	Issue Date	Amount
maint		\$13.25
Reg		\$1,349.78
Sped		\$56.70
		\$1,419.73

Payee	Amount	Type
Johnson County Hospital	\$1,766.80	Accounts Payable

Description	Issue Date	Amount
		\$449.00
		\$44.22
ELEM		\$887.08
3-5		\$28.14
High		\$84.42
ELEM		\$121.94
		\$152.00
		\$1,766.80

Payee	Amount	Type
KSB SCHOOL LAW	\$989.28	Accounts Payable

Description	Issue Date	Amount
		\$989.28
		\$989.28

Payee	Amount	Type
KUDU LAWN CARE	\$205.00	Accounts Payable

Description	Issue Date	Amount
		\$205.00
		\$205.00

Payee	Amount	Type
Life Track Services	\$174.00	Accounts Payable

Description	Issue Date	Amount
program a--3 surveys 12 seniors	10/15/2020	\$174.00

		\$174.00
Payee MARSHALL KATIE B	Amount \$115.38	Type Accounts Payable
Description	Issue Date	Amount
		\$115.38
		\$115.38
Payee Matheson Trigas DBA Linweld	Amount \$34.62	Type Accounts Payable
Description	Issue Date	Amount
		\$34.62
		\$34.62
Payee Menards	Amount \$116.07	Type Accounts Payable
Description	Issue Date	Amount
		\$116.07
		\$116.07
Payee Nebraska Public Power Distric	Amount \$3,190.37	Type Accounts Payable
Description	Issue Date	Amount
		\$3,190.37
		\$3,190.37
Payee O'keefe Elevator Company, Inc.	Amount \$340.86	Type Accounts Payable
Description	Issue Date	Amount
		\$340.86
		\$340.86
Payee ONE SOURCE	Amount \$25.00	Type Accounts Payable
Description	Issue Date	Amount
		\$25.00
		\$25.00
Payee PYRAMID SCHOOL PRODUCTS	Amount \$1,192.85	Type Accounts Payable
Description	Issue Date	Amount
		\$1,192.85
		\$1,192.85

Payee	Amount	Type
Recycling Enterprises	\$60.00	Accounts Payable
Description	Issue Date	Amount
		\$60.00
		\$60.00
Payee	Amount	Type
School Specialty	\$27.10	Accounts Payable
Description	Issue Date	Amount
		\$27.10
		\$27.10
Payee	Amount	Type
Sprague, Ida Rose	\$73.90	Accounts Payable
Description	Issue Date	Amount
		\$73.90
		\$73.90
Payee	Amount	Type
SYSCO OF LINCOLN	\$6,069.42	Accounts Payable
Description	Issue Date	Amount
		\$475.15
		\$1,666.09
		\$194.01
		\$812.68
		\$502.28
		\$1,418.16
		\$928.69
		\$72.36
		\$6,069.42
Payee	Amount	Type
T.O. Haas	\$43.70	Accounts Payable
Description	Issue Date	Amount
truck mount/repair		\$43.70
		\$43.70
Payee	Amount	Type
Tecumseh Chieftain	\$196.08	Accounts Payable
Description	Issue Date	Amount
		\$196.08
		\$196.08
Payee	Amount	Type

The Home Depot Pro	\$120.16	Accounts Payable
Description	Issue Date	Amount
water filters for fountains, boosters will send a check		\$120.16
		\$120.16
Payee	Amount	Type
Trane US, Inc	\$57.25	Accounts Payable
Description	Issue Date	Amount
		\$57.25
		\$57.25
Payee	Amount	Type
U.S. Cellular	\$42.46	Accounts Payable
Description	Issue Date	Amount
		\$42.46
		\$42.46
Payee	Amount	Type
UNITE PRIVATE NETWORKS, LLC	\$554.00	Accounts Payable
Description	Issue Date	Amount
		\$554.00
		\$554.00
Payee	Amount	Type
United States Postal Service	\$7.75	Accounts Payable
Description	Issue Date	Amount
		\$7.75
		\$7.75
Payee	Amount	Type
Village Of Sterling	\$172.00	Accounts Payable
Description	Issue Date	Amount
		\$172.00
		\$172.00
Payee	Amount	Type
WageWorks, Inc	\$50.00	Accounts Payable
Description	Issue Date	Amount
flex dues		\$50.00
		\$50.00
Payee	Amount	Type
WASTE CONNECTIONS OF NEBRASKA	\$400.00	Accounts Payable
Description	Issue Date	Amount

		\$400.00
		\$400.00
Payee	Amount	Type
Waymire Well Drilling, Inc.	\$91.00	Accounts Payable
Description	Issue Date	Amount
		\$91.00
		\$91.00
Payee	Amount	Type
WINDSTREAM COMMUNICATIONS, INC	\$806.28	Accounts Payable
Description	Issue Date	Amount
		\$806.28
		\$806.28
Payee	Amount	Type
Wirthele, Cheri J	\$25.00	Accounts Payable
Description	Issue Date	Amount
		\$25.00
		\$25.00
		\$310,361.24

Sterling Public Schools

Check Report

Begin Date: 10/22/2020; End Date: 11/12/2020; Check Type: Accounts Payable and Payroll Liability; Payee: [All]; Bank: [All]; Accounting Cycle: FY20/21; Limit Res 12:27:45 PM

Voucher Number	Bank Name	Account Number	Check Number
October hours/November Pay	First National Bank	8059655	30200
Vendor	Deduction Name	Register Number	Account Code
Aflac	Aflac Accident Ins	136	01-941-000
Aflac	Aflac Cancer PreTax	136	01-941-000
Aflac	Aflac Hospital	136	01-941-000
Aflac	Aflac Special Event	136	01-941-000
Aflac	Aflac Accident Ins	136	06-941-000
Aflac	Aflac Accident Ins	136	10-941-000
Sub Total			
Voucher Number	Bank Name	Account Number	Check Number
October hours/November Pay	First National Bank	8059655	30201
Vendor	Deduction Name	Register Number	Account Code
Ameritas	Vision Ins E/Sp	136	01-941-000
Ameritas	Vision Ins Fam	136	01-941-000
Ameritas	Vision Ins Single	136	01-941-000
Ameritas	Vision Ins E/Sp	136	10-941-000
Sub Total			
Voucher Number	Bank Name	Account Number	Check Number
October hours/November Pay	First National Bank	8059655	30202
Vendor	Deduction Name	Register Number	Account Code
Blue Cross/Blue Shield	BCBS Dental-Dist Pd Single	136	01-941-000
Blue Cross/Blue Shield	Dental Ins E/Sp	136	01-941-000
Blue Cross/Blue Shield	Dental Ins Fam	136	01-941-000
Blue Cross/Blue Shield	BCBS Medical-Dist Pd E/Sp	136	01-941-009
Blue Cross/Blue Shield	BCBS Medical-Dist Pd Fam	136	01-941-009
Blue Cross/Blue Shield	BCBS Medical-Dist Pd Fam HD	136	01-941-009
Blue Cross/Blue Shield	BCBS Medical-Dist Pd Single	136	01-941-009
Blue Cross/Blue Shield	BCBS Dental-Dist Pd Single	136	10-941-000
Blue Cross/Blue Shield	Dental Ins Fam	136	10-941-000
Blue Cross/Blue Shield	BCBS Medical-Dist Pd Fam	136	10-941-009
Sub Total			
Voucher Number	Bank Name	Account Number	Check Number
October hours/November Pay	First National Bank	8059655	30203
Vendor	Deduction Name	Register Number	Account Code

Credit Management Services v. Angela Heidtbrink	Credit Management Services v. Angela Heidtbrink	136	01-941-000
Sub Total			
Voucher Number October hours/November Pay	Bank Name First National Bank	Account Number 8059655	Check Number 30204
Vendor	Deduction Name	Register Number	Account Code
First Bank of NE credit A Allen HSA account	Adrian Allen HSA account Employee Deduction	136	01-941-001
Sub Total			
Voucher Number October hours/November Pay	Bank Name First National Bank	Account Number 8059655	Check Number 30205
Vendor	Deduction Name	Register Number	Account Code
First Bank of NE credit A Heusman HSA account	Addie Heusman HSA account Employee Deduction	136	01-941-001
Sub Total			
Voucher Number October hours/November Pay	Bank Name First National Bank	Account Number 8059655	Check Number 30206
Vendor	Deduction Name	Register Number	Account Code
FirstBank of Nebraska	FICA	136	01-941-000
FirstBank of Nebraska	Medicare	136	01-941-000
FirstBank of Nebraska	Federal Withholding	136	01-941-002
FirstBank of Nebraska	FICA	136	01-941-004
FirstBank of Nebraska	Medicare	136	01-941-005
FirstBank of Nebraska	FICA	136	06-941-000
FirstBank of Nebraska	Medicare	136	06-941-000
FirstBank of Nebraska	Federal Withholding	136	06-941-002
FirstBank of Nebraska	FICA	136	06-941-004
FirstBank of Nebraska	Medicare	136	06-941-005
FirstBank of Nebraska	FICA	136	10-941-000
FirstBank of Nebraska	Medicare	136	10-941-000
FirstBank of Nebraska	Federal Withholding	136	10-941-002
FirstBank of Nebraska	FICA	136	10-941-004
FirstBank of Nebraska	Medicare	136	10-941-005
Sub Total			
Voucher Number October hours/November Pay	Bank Name First National Bank	Account Number 8059655	Check Number 30207
Vendor	Deduction Name	Register Number	Account Code
Kathleen A Laughlin, Chapter 13 Trustee	Kathleen A. Laughlin, Chapter 13 Trustee	136	06-941-000
Sub Total			
Voucher Number October hours/November Pay	Bank Name First National Bank	Account Number 8059655	Check Number 30208
Vendor	Deduction Name	Register Number	Account Code

Nebraska Department of Revenue	Nebraska Department of Revenue	136	01-941-000
Sub Total			
Voucher Number	Bank Name	Account Number	Check Number
October hours/November Pay	First National Bank	8059655	30209
Vendor	Deduction Name	Register Number	Account Code
Nebraska Dept Of Revenue	State Withholding - NE	136	01-941-000
Nebraska Dept Of Revenue	State Withholding - NE	136	06-941-000
Nebraska Dept Of Revenue	State Withholding - NE	136	10-941-000
Sub Total			
Voucher Number	Bank Name	Account Number	Check Number
October hours/November Pay	First National Bank	8059655	30210
Vendor	Deduction Name	Register Number	Account Code
Nebraska Retirement	NPERS	136	01-941-000
Nebraska Retirement	NPERS	136	06-941-000
Nebraska Retirement	NPERS	136	10-941-000
Sub Total			
Voucher Number	Bank Name	Account Number	Check Number
October hours/November Pay	First National Bank	8059655	30211
Vendor	Deduction Name	Register Number	Account Code
PRINCIPAL LIFE GROUP	Princ Term Life Aft Tax	136	01-941-000
PRINCIPAL LIFE GROUP	Principal LTDSTD Hourly	136	01-941-000
PRINCIPAL LIFE GROUP	Principal LTDSTD Supt	136	01-941-000
PRINCIPAL LIFE GROUP	PrincpalLTDSTD Teacher	136	01-941-000
PRINCIPAL LIFE GROUP	Princ Term Life Aft Tax	136	06-941-000
PRINCIPAL LIFE GROUP	Principal LTDSTD Hourly	136	06-941-000
PRINCIPAL LIFE GROUP	Princ Term Life Aft Tax	136	10-941-000
PRINCIPAL LIFE GROUP	PrincpalLTDSTD Teacher	136	10-941-000
Sub Total			
Voucher Number	Bank Name	Account Number	Check Number
October hours/November Pay	First National Bank	8059655	30212
Vendor	Deduction Name	Register Number	Account Code
SECURITY BENEFIT	FSC Sec Corporation	136	01-941-000
SECURITY BENEFIT	FSC Sec Roth	136	01-941-000
Sub Total			
Voucher Number	Bank Name	Account Number	Check Number
October hours/November Pay	First National Bank	8059655	30213
Vendor	Deduction Name	Register Number	Account Code
WageWorks, Inc	Childcare	136	01-941-000
WageWorks, Inc	Medical FLEX	136	01-941-000

WageWorks, Inc	Medical FLEX	136	10-941-000
Sub Total			
Voucher Number	Bank Name	Account Number	Check Number
October hours/November Pay	First National Bank	8059655	EFT
Vendor	Deduction Name	Register Number	Account Code
FirstBank of Nebraska	Direct Deposit	136	01-941-001
FirstBank of Nebraska	Direct Deposit	136	06-941-001
FirstBank of Nebraska	Direct Deposit	136	10-941-001
Sub Total			
Grand Total			

Results to This Cycle: Yes; Account Expression: [All]; Show Detail by Voucher: Yes; Created On: 11/12/2020

Payee	Amount	Type
Aflac	\$1,071.37	Payroll Liability
Amount		
\$473.96		
\$320.83		
\$66.43		
\$150.02		
\$50.18		
\$9.95		
\$1,071.37		
Payee	Amount	Type
Ameritas	\$142.28	Payroll Liability
Amount		
\$9.44		
\$72.64		
\$56.16		
\$4.04		
\$142.28		
Payee	Amount	Type
Blue Cross/Blue Shield	\$31,678.66	Payroll Liability
Amount		
\$581.94		
\$32.46		
\$682.65		
\$1,436.65		
\$16,782.73		
\$8,137.95		
\$3,420.60		
\$8.86		
\$16.10		
\$578.72		
\$31,678.66		
Payee	Amount	Type
Credit Management Services v. Angela Heidtbrink	\$28.96	Payroll Liability
Amount		

	\$28.96	
	\$28.96	
Payee	Amount	Type
First Bank of NE credit A Allen HSA	\$100.00	Payroll Liability
	Amount	
	\$100.00	
	\$100.00	
Payee	Amount	Type
First Bank of NE credit A Heusman HSA account	\$200.00	Payroll Liability
	Amount	
	\$200.00	
	\$200.00	
Payee	Amount	Type
Tax Checks	\$36,280.05	Payroll Liability
	Amount	
	\$10,088.88	
	\$2,359.52	
	\$9,989.85	
	\$10,088.88	
	\$2,359.52	
	\$397.07	
	\$92.85	
	\$91.55	
	\$397.07	
	\$92.85	
	\$90.42	
	\$21.15	
	\$98.87	
	\$90.42	
	\$21.15	
	\$36,280.05	
Payee	Amount	Type
Kathleen A Laughlin, Chapter 13 Trustee	\$254.00	Payroll Liability
	Amount	
	\$254.00	
	\$254.00	
Payee	Amount	Type
Nebraska Department of Revenue	\$204.12	Payroll Liability
	Amount	

	\$204.12	
	\$204.12	
Payee	Amount	Type
Nebraska Dept Of Revenue	\$5,047.00	Payroll Liability
	Amount	
	\$4,888.57	
	\$111.14	
	\$47.29	
	\$5,047.00	
Payee	Amount	Type
Nebraska Retirement	\$32,132.40	Payroll Liability
	Amount	
	\$30,567.23	
	\$1,267.77	
	\$297.40	
	\$32,132.40	
Payee	Amount	Type
PRINCIPAL LIFE GROUP	\$492.85	Payroll Liability
	Amount	
	\$56.10	
	\$30.34	
	\$47.25	
	\$344.00	
	\$3.00	
	\$5.26	
	\$0.90	
	\$6.00	
	\$492.85	
Payee	Amount	Type
SECURITY BENEFIT	\$3,500.00	Payroll Liability
	Amount	
	\$3,000.00	
	\$500.00	
	\$3,500.00	
Payee	Amount	Type
WageWorks, Inc	\$1,642.52	Payroll Liability
	Amount	
	\$1,322.21	
	\$290.35	

	\$29.96	
	\$1,642.52	
Payee	Amount	Type
Direct Deposit Bank	\$119,316.50	Payroll Liability
	Amount	
	\$113,572.11	
	\$4,698.53	
	\$1,045.86	
	\$119,316.50	
	\$232,090.71	

Sterling Public Schools

Monthly Balance Forecast Report

Cycle: FY20/21; Begin Date: 09/01/2020; End Date: 11/30/2020; Account Type: Expenditure,Revenue; Account Expression: [All]; Created On: 11/12/2020 12:33:59 PM

Expenditure					
Description	September	October	November	Total (Date Range)	Budget (YTD)
01100 - Regular Instruction	(\$169,360.01)	(\$126,785.49)	(\$127,105.83)	(\$423,251.33)	\$0.00
01190 - Early Childhood Educational Programs	(\$17,809.44)	(\$17,370.74)	(\$16,572.43)	(\$51,752.61)	\$0.00
01200 - Special Education Instructional Programs - School Age	(\$31,021.02)	(\$23,517.20)	(\$24,557.44)	(\$79,095.66)	\$0.00
01300 - Summer School	\$0.00	(\$25.96)	(\$25.96)	(\$51.92)	\$0.00
02120 - Guidance Services	(\$9,415.41)	(\$10,757.04)	(\$8,383.57)	(\$28,556.02)	\$0.00
02140 - Psychological Services	(\$348.00)	(\$638.00)	\$0.00	(\$986.00)	\$0.00
02141 - Psychological Services - SPED - School Age	\$0.00	(\$4,666.50)	(\$5,159.72)	(\$9,826.22)	\$0.00
02151 - Speech Pathology and Audiology Services - SPED - School Age	\$0.00	(\$6,046.50)	(\$5,986.50)	(\$12,033.00)	\$0.00
02161 - Occupational Therapy-Related Services - SPED - School Age	(\$234.50)	(\$1,683.71)	(\$887.08)	(\$2,805.29)	\$0.00
02162 - Occupational Therapy-Related Services - SPED - Ages 3-5	\$0.00	\$0.00	(\$112.56)	(\$112.56)	\$0.00
02171 - Physical Therapy-Related Services - SPED - School Age	(\$33.50)	\$0.00	(\$121.94)	(\$155.44)	\$0.00
02181 - Visually Impaired or Vision Services - SPED - School Age	(\$284.40)	(\$284.40)	(\$14.90)	(\$583.70)	\$0.00
02190 - Support Services - Student - Other	(\$92.55)	(\$184.22)	(\$323.20)	(\$599.97)	\$0.00
02213 - Instructional Staff Training	(\$250.00)	\$0.00	\$0.00	(\$250.00)	\$0.00
02220 - Library or Media Services	(\$3,957.90)	(\$3,874.30)	(\$4,082.43)	(\$11,914.63)	\$0.00
02230 - Instruction-Related Technology	(\$631.50)	(\$9,329.05)	(\$20,631.50)	(\$30,592.05)	\$0.00
02290 - Other Support Services - Instructional Staff	\$0.00	(\$638.03)	\$0.00	(\$638.03)	\$0.00
02310 - Board of Education	(\$133.78)	(\$939.96)	(\$203.83)	(\$1,277.57)	\$0.00
02320 - Executive Administration	(\$13,283.28)	(\$12,872.85)	(\$12,859.20)	(\$39,015.33)	\$0.00
02330 - District Legal Services	(\$50.00)	(\$110.00)	(\$989.28)	(\$1,149.28)	\$0.00
02410 - Office of the Principal	(\$13,048.71)	(\$12,619.74)	(\$12,909.25)	(\$38,577.70)	\$0.00
02510 - Fiscal Services	(\$3,806.14)	(\$3,865.95)	(\$4,159.08)	(\$11,831.17)	\$0.00
02530 - Printing, Publishing, and Duplicating Services	(\$1,065.42)	(\$775.30)	(\$2,557.11)	(\$4,397.83)	\$0.00
02570 - Personnel Services	\$0.00	(\$120.00)	(\$50.00)	(\$170.00)	\$0.00
02580 - Administrative Technology Service	(\$99.00)	(\$186.76)	(\$695.38)	(\$981.14)	\$0.00
02610 - Operation of Buildings	(\$10,375.47)	(\$15,190.54)	(\$15,238.87)	(\$40,804.88)	\$0.00
02620 - Maintenance of Buildings	(\$248.23)	(\$6,511.93)	(\$625.47)	(\$7,385.63)	\$0.00
02630 - Care and Upkeep of Grounds	(\$1,216.39)	(\$352.44)	(\$487.98)	(\$2,056.81)	\$0.00
02710 - Vehicle Operation and Purchasing - Regular Education	(\$5,478.91)	(\$8,300.15)	(\$8,905.01)	(\$22,684.07)	\$0.00
02712 - Vehicle Operation and Purchasing - School Age SPED	(\$162.26)	(\$181.78)	(\$224.44)	(\$568.48)	\$0.00
02730 - Vehicle Servicing and Maintenance - Regular Education	(\$2,712.54)	(\$784.93)	(\$43.70)	(\$3,541.17)	\$0.00
02732 - Vehicle Servicing and Maintenance - School Age SPED	(\$100.00)	\$0.00	\$0.00	(\$100.00)	\$0.00
02790 - Other Student Transportation Services - Regular Students	(\$100.00)	(\$100.00)	\$0.00	(\$200.00)	\$0.00
02792 - Other Student Transportation Services - School Age SPED	(\$400.05)	(\$349.31)	\$0.00	(\$749.36)	\$0.00
02900 - Other Support Services	(\$17,019.00)	(\$12,947.54)	(\$7,015.27)	(\$36,981.81)	\$0.00
03100 - Food Services Operations	(\$13,266.36)	(\$15,108.68)	(\$16,290.01)	(\$44,665.05)	\$0.00
05000 - Debt Service	\$0.00	\$0.00	(\$228,918.75)	(\$228,918.75)	\$0.00
06200 - Federal Services - Title I, Part A ESSA Improving Basic Programs Operated by Local Educational Agencies	(\$8,129.08)	(\$8,058.24)	(\$8,031.08)	(\$24,218.40)	\$0.00
06210 - Federal Services - Title I, Part A Accountability ESSA Improving Basic Programs	(\$10,765.00)	\$0.00	\$0.00	(\$10,765.00)	\$0.00
06408 - IDEA Part B (611) Base & Enrollment Poverty Allocation Ages 0-21	(\$4,200.00)	(\$6,524.33)	(\$2,324.33)	(\$13,048.66)	\$0.00
06992 - Federal Services - REAP	(\$23,939.00)	\$0.00	\$0.00	(\$23,939.00)	\$0.00
Sub Total	(\$363,036.85)	(\$311,701.57)	(\$536,493.10)	(\$1,211,231.52)	\$0.00
Revenue					
Description	September	October	November	Total (Date Range)	Budget (YTD)
01100 - Taxes Levied/Assessed by the School District	\$819,996.47	\$177,681.27	\$0.00	\$997,677.74	\$0.00

01115 - Carline Taxes	\$1,308.22	\$0.00	\$0.00	\$1,308.22	\$0.00
01125 - Motor Vehicle Taxes	\$9,767.20	\$8,515.30	\$0.00	\$18,282.50	\$0.00
01140 - Penalties and Interest on Taxes	\$234.90	\$1,341.02	\$0.00	\$1,575.92	\$0.00
01510 - Interest on Investments	\$37.59	\$39.55	\$0.00	\$77.14	\$0.00
01611 - Daily Sales?School Lunch Program	\$5,090.82	\$530.50	\$0.00	\$5,621.32	\$0.00
01740 - Fees	\$50.00	\$0.00	\$0.00	\$50.00	\$0.00
01900 -	\$0.00	\$75.00	\$0.00	\$75.00	\$0.00
01920 - Contributions and Donations From Private Sources	\$0.00	\$200.00	\$0.00	\$200.00	\$0.00
01980 - Refund of Prior Year?s Expenditures	\$0.00	\$1,055.00	\$0.00	\$1,055.00	\$0.00
01990 - Miscellaneous Local Revenue	\$200.00	\$925.26	\$0.00	\$1,125.26	\$0.00
02110 - County Fines & License Fees	\$748.84	\$926.64	\$0.00	\$1,675.48	\$0.00
02130 - Other County Receipts	\$138.77	\$0.00	\$0.00	\$138.77	\$0.00
03110 - State Aid	\$2,334.00	\$2,334.00	\$0.00	\$4,668.00	\$0.00
03180 - Pro-Rate Motor Vehicle	\$0.00	\$741.28	\$0.00	\$741.28	\$0.00
03512 - Distance Education Incentive Payments	\$0.00	\$3,859.64	\$0.00	\$3,859.64	\$0.00
03535 - Payment for High Ability Learners	\$0.00	\$3,275.00	\$0.00	\$3,275.00	\$0.00
Sub Total	\$839,906.81	\$201,499.46	\$0.00	\$1,041,406.27	\$0.00
Grand Total	\$476,869.96	(\$110,202.11)	(\$536,493.10)	(\$169,825.25)	\$0.00

Adrian Allen
Superintendent

Jacob Davenport
Principal & Activities Director

Brent Heusman
Athletic Director

Addie Heusman
School Counselor

STERLING PUBLIC SCHOOLS



"HOME OF THE JETS"

250 MAIN STREET · P.O. BOX 39 · STERLING, NEBRASKA 68443

PHONE (402) 866-4761
FAX (402) 866-4771

November 16, 2020

Dear National Honor Society,

The Sterling Board of Education and Administration would like to commend you for your success of the blood drive held on November 12, 2020 and filling all of the available appointments. Your organization demonstrates a strong commitment to community relations and the overall health of our community. The members of the organization are strong role models for the students of Sterling Public Schools and your continued dedication to excellent was shown once again at the blood drive.

We greatly appreciate your commitment to our school and community! Go Jets!

Yours Truly,

Adrian Allen
Superintendent

Jacob Davenport
Principal & Activities Director

Brent Heusman
Athletic Director

Addie Heusman
School Counselor

STERLING PUBLIC SCHOOLS



"HOME OF THE JETS"

250 MAIN STREET · P.O. BOX 39 · STERLING, NEBRASKA 68443

PHONE (402) 866-4761
FAX (402) 866-4771

November 16, 2020

Dear John Keizer,

The Sterling Board of Education and Administration would like to commend you for being our honored speaker at our Veteran's Day celebration. We appreciate the stories and wisdom that you shared with our students and the community. We appreciate your military service and your service to the school and community.

Thank you again for sharing your voice with us at Sterling Public Schools! Go Jets!

Yours Truly,

Continuing a Tradition of Excellence

Adrian Allen
Superintendent

Jacob Davenport
Principal & Activities Director

Brent Heusman
Athletic Director

Addie Heusman
School Counselor

STERLING PUBLIC SCHOOLS

"HOME OF THE JETS"

250 MAIN STREET · P.O. BOX 39 · STERLING, NEBRASKA 68443



PHONE (402) 866-4761
FAX (402) 866-4771

November 16, 2020

Dear Luke Boldt,

The Sterling Board of Education and Administration would like to commend you for your efforts in orchestrating another successful Veteran's Day celebration. In spite of all of the recent challenges, this year's celebration was outstanding. Your commitment to honoring our Veterans, educating our students, and representing the school did not go unnoticed.

We greatly appreciate your commitment to our school and community! Go Jets!

Yours Truly,

Continuing a Tradition of Excellence

BEATRICE MECHANICAL SERVICE INC.

**"Small Town Friendly Service, Big City
Performance and Professionalism"**

2403 CENTENNIAL DRIVE
POST OFFICE BOX 6
BEATRICE, NE 68310

www.beatricemechanical.net

Telephone 402/223-5663
Fax 402/228-1896

10/12/2020

Mr. Adrian Allen, Superintendent
Sterling Public Schools
250 Main Street
Sterling, NE 68443

RE: Proposal to Replace Water Source Heat Pump in Ceiling of Chemistry Storage Area.

Dear Mr. Allen:

Please accept this letter as our proposal for the above referenced project. Beatrice Mechanical proposes the following scope of work.

- We will remove and dispose of the existing 4 ton, horizontal configuration, water source heat pump. The existing Trane heat pump controller will be retained and reused.
- We will provide and install a Water Furnace UBH048 water source heat pump. This is the same capacity as the heat pump removed. New heat pump will be provided with new hose connection kit and circuit balancing valve.
- We will connect the new heat pump to the existing electrical service, air duct system, condensate drain service, building automation system, and heat pump water loop.
- We will start up, test, and operate the new system.

Beatrice Mechanical proposes to provide the scope of work as outlined above for a total installed price of \$5,985.00. Warranty on the scope of work above is one year parts, one year labor, and five years parts only on the hermetic compressor.

Thank you for the opportunity to quote this project. Please feel free to contact me if you need any additional information.

Sincerely,



Beatrice Mechanical Service Inc.
Dennis M Schuster, President

Enclosure



Versatec Compact

Commercial 0.5 to 6 Ton
Geothermal/Water Source Heat Pump



Submittal Data
English Language/IP Units
SD1202AU 02/19

Contractor: _____ P.O.: _____

Engineer: _____

Project Name: _____ Unit Tag: _____

Versatec Compact Series Commercial 0.5-6 Ton 60Hz



Model Nomenclature

Model# UBH048ER300DBNAN2B30SS

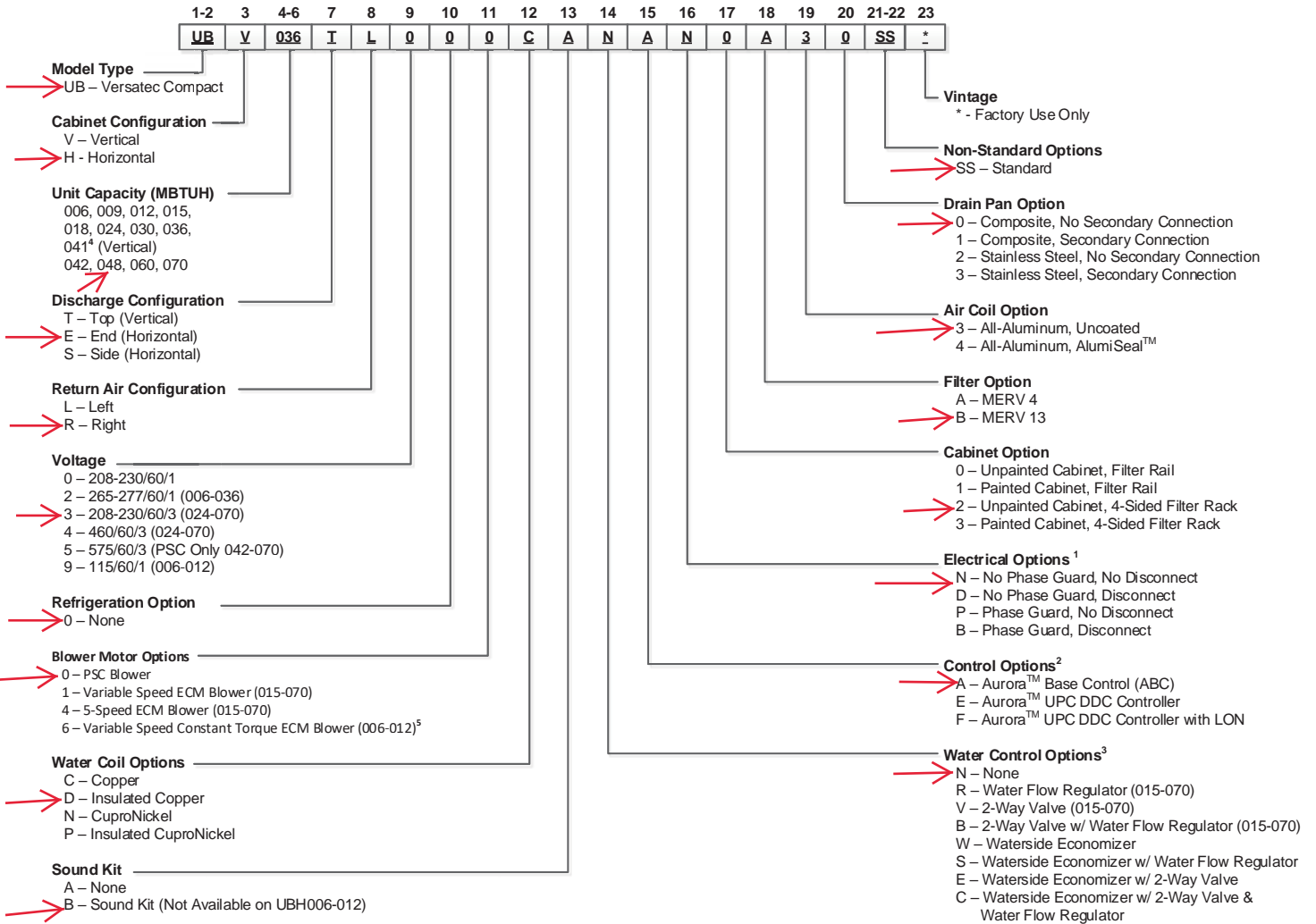

Note:

- 1 - Phase Guard Only Available on 208-230/60/3 and 460/60/3
- 2 - 50VA transformer with Aurora Base Control, and 75VA transformer with Aurora UPC control
- 3 - Waterside economizer option must be ordered with stainless steel drain pan and either 5-speed ECM or variable speed ECM (024-070)
- 4 - 2 way valve, water flow regulator, economizer, disconnect, 2" filter and filter rack not available in UBV041.
- 5 - Blower Motor option "6" only available in 115/60/1 and 208-230/60/1.

Note: See separate manual for economizer option



All Versatec Compact Series product is safety listed under UL1995 thru ETL and performance listed with AHRI in accordance with standard 13256-1.

WaterFurnace works continually to improve its products. As a result, the design and specifications of each product at the time of order may be changed without notice. Please contact WaterFurnace at 1-888-929-2837 for latest design and specifications. Purchaser's approval of this data set signifies that the equipment is acceptable under the provisions of the job specification. Statements and other information contained herein are not express warranties and do not form the basis of any bargain between the parties, but are merely WaterFurnace's opinion or commendation of its products. The latest version of this document is available at www.waterfurnace.com.

Contractor: _____ P.O.: _____

Engineer: _____

Project Name: _____ Unit Tag: _____

Horizontal Dimensional Data

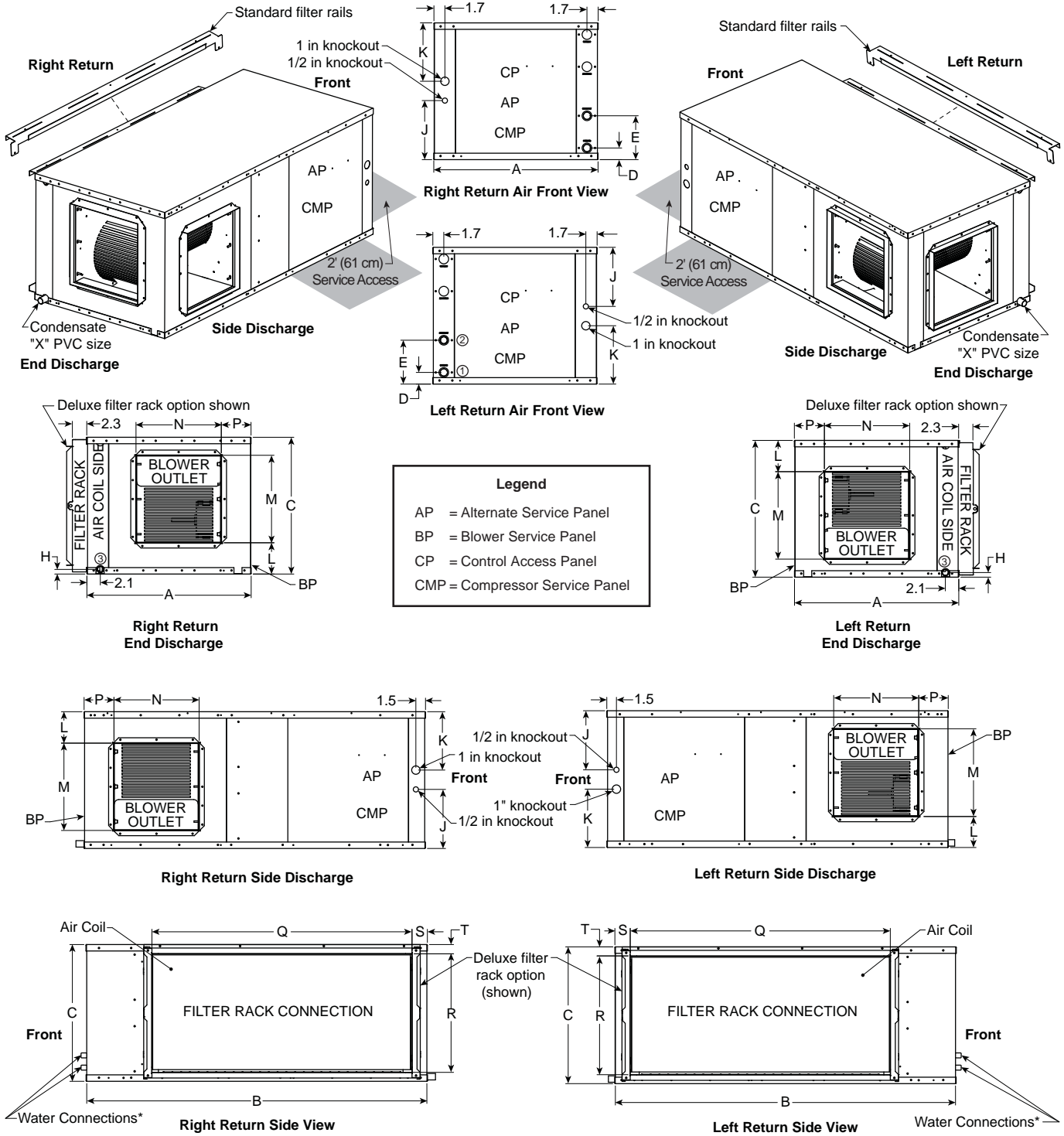

NOTE: * Water connections protrude approximately 1.5 in. from cabinet.

WaterFurnace works continually to improve its products. As a result, the design and specifications of each product at the time of order may be changed without notice. Please contact WaterFurnace at 1-888-929-2837 for latest design and specifications. Purchaser's approval of this data set signifies that the equipment is acceptable under the provisions of the job specification. Statements and other information contained herein are not express warranties and do not form the basis of any bargain between the parties, but are merely WaterFurnace's opinion or commendation of its products. The latest version of this document is available at www.waterfurnace.com.

Contractor: _____ P.O.: _____
 Engineer: _____
 Project Name: _____ Unit Tag: _____

**Versatec Compact Series
 Commercial 0.5-6 Ton 60Hz**



Horizontal Dimensional Data cont.

Horizontal Models	Overall Cabinet			Water Connections				Electrical Knockouts		
	A	B	C	1	2	3	Loop	J	K	
	Width	Depth	Height*	D	E	H		1/2 in. cond	1 in. cond	
				In	Out	Condensate	Water FPT	Low Voltage	Power Supply	
006-012**	in.	19.2	35.0	12.1	1.8	4.8	3.6	1/2 in.	7.4	7.5
	cm.	48.8	88.9	30.7	4.6	12.2	9.1	12.70 mm	18.8	19.1
015-018	in.	22.5	35.0	17.2	1.8	6.8	0.8	3/4 in.	7.1	7.1
	cm.	57.2	88.9	43.7	4.6	17.3	2.0	19.05 mm	18.0	18.0
024-030	in.	22.5	42.0	17.2	1.8	6.8	0.8	3/4 in.	7.1	7.1
	cm.	57.2	106.7	43.7	4.6	17.3	2.0	19.05 mm	18.0	18.0
036	in.	22.5	42.0	19.2	1.8	6.8	0.8	3/4 in.	9.2	7.1
	cm.	57.2	106.7	48.8	4.6	17.3	2.0	19.05 mm	23.4	18.0
042-048	in.	22.5	45.0	19.2	1.8	6.8	0.8	3/4 in.	9.2	7.1
	cm.	57.2	114.3	48.8	4.6	17.3	2.0	19.05 mm	23.4	18.0
060	in.	25.5	48.0	21.2	1.8	6.8	0.8	1 in.	9.2	9.1
	cm.	64.8	121.9	53.8	4.6	17.3	2.0	25.4 mm	23.4	23.1
070	in.	25.5	53.0	21.2	1.8	6.8	0.8	1 in.	9.2	9.1
	cm.	64.8	134.6	53.8	4.6	17.3	2.0	25.4 mm	23.4	23.1

Horizontal Models	Discharge Connection duct flange installed (30.10 in)				Return Connection using deluxe filter rack option (30.10 in)				PVC Size	
	L	M	N	P	Q	R	S	T	X	
		Supply Width	Supply Depth		Return Depth	Return Height				
006-012**	in.	2.3	8.0	10.0	2.7	22.5	9.4	2.4	1.4	1/2 in.
	cm.	5.8	20.3	25.4	6.9	57.2	23.9	6.1	3.6	1.3
015-018	in.	5.7	10.5	9.4	4.9	16.4	14.5	2.0	1.4	3/4 in.
	cm.	14.5	26.7	23.9	12.4	41.7	36.8	5.1	3.6	1.9
024-030	in.	5.7	10.5	9.4	4.9	23.4	14.5	2.0	1.4	3/4 in.
	cm.	14.5	26.7	23.9	12.4	59.4	36.8	5.1	3.6	1.9
036	in.	6.7	10.5	9.4	4.9	27.4	16.5	2.0	1.4	3/4 in.
	cm.	17.0	26.7	23.9	12.4	69.6	41.9	5.1	3.6	1.9
042-048	in.	4.2	13.6	13.2	2.4	30.4	16.5	2.0	1.5	3/4 in.
	cm.	10.7	34.5	33.5	6.1	77.2	41.9	5.1	3.8	1.9
060	in.	4.8	13.6	13.2	4.6	35.4	18.7	2.3	1.3	3/4 in.
	cm.	12.2	34.5	33.5	11.7	89.9	47.5	5.8	3.3	1.9
070	in.	4.8	13.6	13.2	4.6	40.4	18.5	2.3	1.4	3/4 in.
	cm.	12.2	34.5	33.5	11.7	102.6	47.0	5.8	3.6	1.9

09/26/12

Horizontal units shipped with standard 2 in. (field adjustable to 1 in.) open application filter rail extending 2.2 in. from the unit and is not suitable for duct connection. For ductable return connection applications, order the 2 in. (field adjustable to 1 in.) duct collar/ filter rack which extends to 3.25 in. from the unit and is suitable for duct connections.

** UBH006-012 offers a lifted drain pan that allows the trap to be installed without additional ceiling height required.

Horizontal Disconnect

When using disconnect, do not use dimension K from the standard horizontal dimensional data. Use dimension KK from the horizontal disconnect dimensional data.

Horizontal Models	KK
015-018	8.2 [20.8]
024-030	8.2 [20.8]
036	9.2 [23.4]
042-048	9.2 [23.4]
060	11.2 [28.4]
070	10.2 [25.9]

Dimensions in inches [cm]

* Models 006-012 - Externally Mounted Disconnect

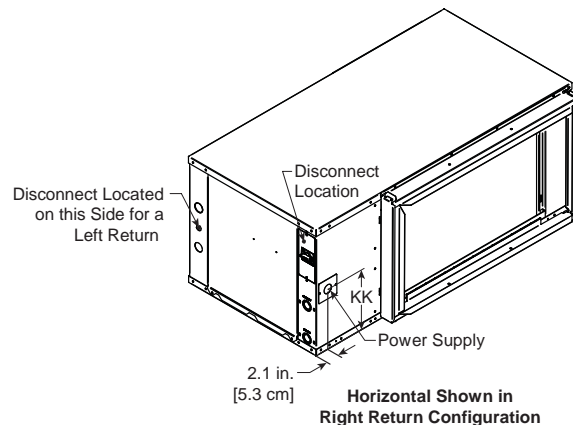

WaterFurnace works continually to improve its products. As a result, the design and specifications of each product at the time of order may be changed without notice. Please contact WaterFurnace at 1-888-929-2837 for latest design and specifications. Purchaser's approval of this data set signifies that the equipment is acceptable under the provisions of the job specification. Statements and other information contained herein are not express warranties and do not form the basis of any bargain between the parties, but are merely WaterFurnace's opinion or commendation of its products. The latest version of this document is available at www.waterfurnace.com.

Contractor: _____ P.O.: _____
 Engineer: _____
 Project Name: _____ Unit Tag: _____

Versatec Compact Series
Commercial 0.5-6 Ton 60Hz



Hanger Bracket Locations

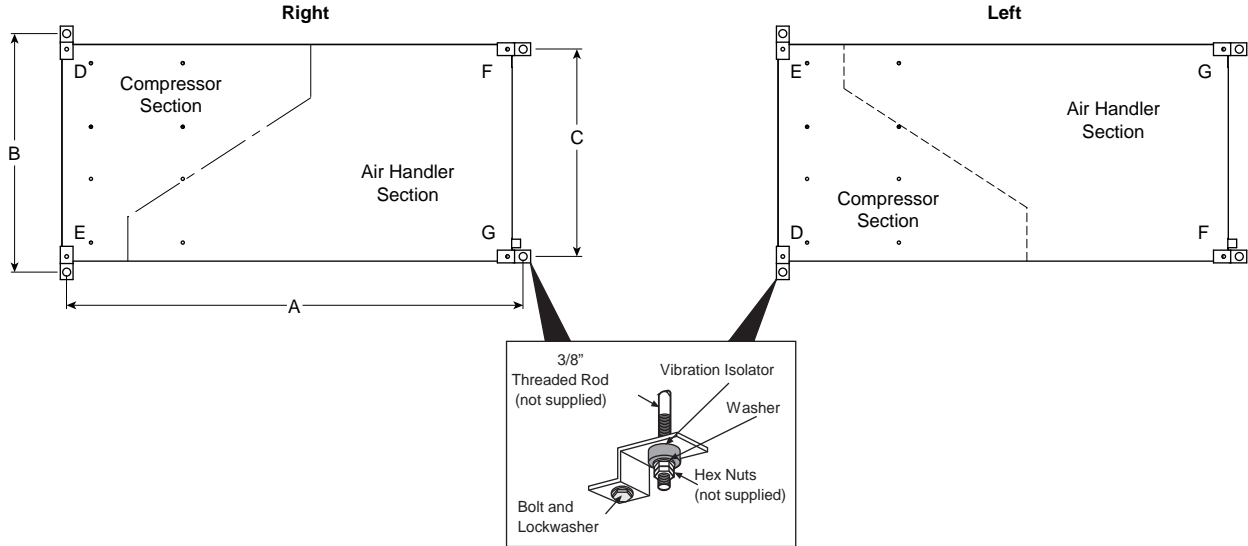

Hanger Dimensions

Model	Hanger Kit Part Number	Unit Hanger Dimensions			
		A	B	C	
006-012	99S500A04	in.	35.8	21.8	18.1
		cm.	90.9	55.4	46.0
015-018	99S500A04	in.	35.8	25.1	21.4
		cm.	90.9	63.8	54.4
024-030	99S500A04	in.	42.8	25.1	21.4
		cm.	108.6	63.8	54.4
036	99S500A04	in.	42.8	25.1	21.4
		cm.	108.7	63.8	54.4
042-048	99S500A04	in.	45.8	25.1	21.4
		cm.	116.3	63.8	54.4
060	99S500A04	in.	48.8	28.1	24.4
		cm.	124.0	71.4	62.0
070	99S500A04	in.	53.8	28.1	24.4
		cm.	136.7	71.4	62.0

09/26/12

Weight Distribution

Model	Vertical Shipping Weight	Horizontal Shipping Weight	Horizontal Weight Distribution				
			Front		Back		
			D	E	F	G	
006-012	lbs	111	112	44	21	19	28
	kg	50	51	20	10	9	12
015-018	lbs	171	176	32	67	32	45
	kg	78	80	15	30	15	20
024	lbs	245	242	47	85	45	65
	kg	111	110	21	39	20	29
030	lbs	245	242	47	85	45	65
	kg	111	110	21	39	20	29
036	lbs	267	265	60	95	50	60
	kg	121	120	27	43	23	27
041	lbs	243	N/A				
	kg	110	N/A				
042	lbs	305	310	68	105	60	77
	kg	138	141	31	48	27	35
048	lbs	305	310	68	105	60	77
	kg	138	141	31	48	27	35
060	lbs	344	350	77	115	68	90
	kg	156	159	35	52	31	41
070	lbs	357	378	80	130	73	95
	kg	162	171	36	59	33	43

10/15/2015

WaterFurnace works continually to improve its products. As a result, the design and specifications of each product at the time of order may be changed without notice. Please contact WaterFurnace at 1-888-929-2837 for latest design and specifications. Purchaser's approval of this data set signifies that the equipment is acceptable under the provisions of the job specification. Statements and other information contained herein are not express warranties and do not form the basis of any bargain between the parties, but are merely WaterFurnace's opinion or commendation of its products. The latest version of this document is available at www.waterfurnace.com.

3004.1 Fiscal Management for Purchasing and Procurement Using Federal Funds

I. Applicability of Policy

This policy applies only to non-construction related purchases undertaken with federal funds which are subject to the federal Uniform Grant Guidance (UGG) and other applicable federal law, including but not limited to the Education Department and General Administration Regulations (EDGAR) and the United States Department of Agriculture (USDA) regulations governing school food service programs. In the event this policy conflicts or is otherwise inconsistent with mandatory provisions of the UGG, EDGAR or other applicable federal law, the mandatory provisions of the laws shall control.

All other non-construction purchases will be governed by the Board's general purchasing policy, which can be found earlier in this subsection. In the event of a conflict between state and federal law, the more stringent requirement shall apply.

This procurement policy shall govern all purchasing activities that relate to any aspect of the National School Lunch and Breakfast Programs. The district's goal is to fully implement all required procurement rules, regulations and policies set forth in 2 CFR 200, 7 CFR parts 210, 3016 and 3019, and by the Nebraska Department of Education.

II. Procurement System

The District maintains the following purchasing procedures.

A. Responsibility for Purchasing

The authority to make purchases shall be governed by the District's purchasing policy, which can be found elsewhere in this section. Except as otherwise provided in the District's purchasing policy, the acquisition of services, equipment, and supplies shall be centralized in the administration office under the supervision of the superintendent of schools, who shall be responsible for developing and administering the purchasing program of the school district. Purchases or commitments of district funds that are not authorized by this policy will be the responsibility of the person making the commitment.

B. Methods of Purchasing

The type of purchase procedures required depends on the cost of the item(s) being purchased.

1. Purchases up to \$10,000 (Micro-Purchases)

Micro-purchase means a purchase of supplies or services using simplified acquisition procedures, the annual aggregate amount of which does not exceed \$10,000. Micro-purchases may be made or awarded without soliciting competitive quotations, to the extent district staff determine that the cost of the purchase is reasonable. For purposes of this policy "reasonable" means the purchase is comparable to market prices for the geographic area.

To the extent practicable, the District distributes micro-purchases equitably among qualified suppliers. The District will follow its standard policy on purchasing, which can be found earlier in this subsection.

2. Purchases between \$10,000 and \$250,000 (Small Purchase Procedures)

Small purchases are purchases that, in the aggregate amount, is more than \$10,000 and less than \$250,000 annually. For small purchases, price or rate quotes shall be obtained in advance from a reasonable number of qualified sources as detailed in the district's standard policies on purchasing and on bid letting and contracts, which can be found earlier in this subsection.

3. Purchases Over \$250,000

a) Sealed Bids (Formal Advertising)

For purchases over \$250,000, the district will generally follow the bidding process outlined in the board's policy on Bidding for Construction, Remodeling, Repair or Site Improvement.

b) Contract/Price Analysis

The District performs a cost or price analysis in connection with every procurement action in excess of \$250,000, including contract modifications. The district will make an independent estimate of costs prior to receiving bids or proposals.

4. Noncompetitive Proposals (Sole Sourcing)

- a) Procurement by noncompetitive proposals is procurement through solicitation of a proposal from only one source and may be used only when one or more of the following circumstances apply:
 - 1) The item is available only from a single source;
 - 2) The public exigency or emergency for the requirement will not permit a delay resulting from competitive solicitation;
 - 3) The federal awarding agency or pass-through entity expressly authorizes noncompetitive proposals in response to a written request from the District; or
 - 4) After solicitation of a number of sources, competition is determined inadequate.
- b) Noncompetitive proposals may only be solicited with the approval of the superintendent or the board. Sufficient and appropriate documentation that justifies the sole sourcing decision must be maintained by the superintendent or designee.
- c) A cost or price analysis will be performed for noncompetitive proposals when the price exceeds \$250,000.

C. Use of Purchase (Debit & Credit) Cards

District use of purchase cards is subject to the policy on purchase cards which can be found elsewhere in this subsection.

D. Federal Procurement System Standards

The district's procurement transactions will be conducted in a manner providing full and open competition consistent with 2 C.F.R §200.319.

The District will maintain and follow general procurement standards consistent with 2 C.F.R. §200.318.

E. Debarment and Suspension

The District awards contracts only to responsible contractors possessing the ability to perform successfully under the terms and conditions of a proposed procurement. Consideration will be given to such matters as contractor integrity, compliance with public policy, record of past performance, and financial and technical resources.

The District may not subcontract with or award subgrants to any person or company who is debarred or suspended. For all contracts over \$25,000 the District verifies that the vendor with whom the District intends to do business with is not excluded or disqualified. 2 C.F.R. Part 200, Appendix II(1) and 2 C.F.R. §§ 180.220 and 180.300.

The District will verify debarment or suspension by revising the excluded parties list on SAM.gov, collecting a certification through the bidding process, and/or by including a debarment and suspension provision in the bid and contract documents. The Superintendent or his/her designee shall be responsible for such verification.

F. Settlements of Issues Arising Out of Procurements

The District alone is responsible, in accordance with good administrative practice and sound business judgment, for the settlement of all contractual and administrative issues arising out of procurements. These issues include, but are not limited to, source evaluation, protests, disputes, and claims. These standards do not relieve the District of any contractual responsibilities under its contracts. Violations of law will be referred to the local, state, or federal authority having proper jurisdiction.

III. Conflict of Interest and Code of Conduct

A. Board and staff member conflicts of interest are governed by the district's conflict of interest policies.

B. Purchases covered by this policy are subject to the following additional provisions.

- 1.** Employees, officers, and agents engaged in the selection, award, and/or administration of district contracts which are prohibited from engaging in such actions if a real or apparent conflict of interest is present.

2. Such a conflict of interest would arise when the employee, officer, or agent, any member of his or her immediate family, his or her partner, or an organization which employs or is about to employ any of the parties indicated herein, has a financial or other interest in or a tangible personal benefit from a firm considered for a contract.
3. The board may determine at its discretion that a financial interest is not substantial enough to give rise to a conflict of interest.

C. Favors and Gifts

The officers, employees, and agents of the District may neither solicit nor accept gratuities, favors, or anything of monetary value from contractors or parties to subcontracts, except that this provision does not prohibit the receipt of unsolicited items of nominal value. For purposes of this policy, "nominal value" means a fair market value of \$25 or less.

D. Enforcement

Disciplinary Actions including, but not limited to, counseling, oral reprimand, written reprimand, suspensions without pay, or termination of employment, will be applied for violations of such standards by officers, employees, or agents of the District.

IV. Property Management Systems

A. Property Classifications

1. Equipment means tangible personal property (including information technology systems) having a useful life of more than one year and a per-unit acquisition cost which equals or exceeds the lesser of the capitalization level established by the District for financial statement purposes, or \$5,000.
2. Supplies means all tangible personal property other than those described in §200.33 Equipment. A computing device is a supply if the acquisition cost is less than the lesser of the capitalization level established by the District for financial statement purposes or \$5,000, regardless of the length of its useful life. 2 C.F.R. §200.94.

3. Computing Devices means machines used to acquire, store, analyze, process, and publish data and other information electronically, including accessories (or "peripherals") for printing, transmitting and receiving, or storing electronic information. 2 C.F.R. §200.20.
4. Capital Assets means tangible or intangible assets used in operations having a useful life of more than one year which are capitalized in accordance with GAAP. Capital assets include:
 - a) Land, buildings (facilities), equipment, and intellectual property (including software) whether acquired by purchase, construction, manufacture, lease-purchase, exchange, or through capital leases; and
 - b) Additions, improvements, modifications, replacements, rearrangements, reinstallations, renovations or alterations to capital assets that materially increase their value or useful life (not ordinary repairs and maintenance). 2 C.F.R. §200.12.

B. Inventory Procedure

Newly purchased property shall be received and inspected by the staff member who ordered it to ensure that that it matches the purchase order, invoice, or contract and that it is in acceptable condition.

Equipment, Computing Devices, and Capital Assets must be tagged with an identification number, manufacturer, model, name of individual who tagged the item, and date tagged).

C. Inventory Records

For equipment, computing devices, and capital assets purchased with federal funds, the following information is maintained in the property management system:

1. Serial number;
2. District identification number;
3. Manufacturer;
4. Model;
5. Date tagged and individual who tagged it;
6. Source of funding for the property;
7. Who holds title;
8. Acquisition date and cost of the property;

9. Percentage of federal participation in the project costs for the federal award under which the property was acquired;
10. Location, use and condition of the property; and
11. Any ultimate disposition data including the date of disposal and sale price of the property.

The inventory list shall be adjusted by the superintendent of schools or his/her designee for property that is sold, lost, stolen, cannot be repaired, or that cannot be located.

D. Physical Inventory

1. A physical inventory of the property must be taken and the results reconciled with the property records at least once every two years.
2. The Superintendent or his/her designee will ensure that the physical inventory is performed. The physical inventory will generally occur during the months of June or July, but may be conducted during other time periods with the approval of the superintendent.

E. Maintenance

In accordance with 2 C.F.R. 313(d)(4), the District maintains adequate maintenance procedures to ensure that property is kept in good condition.

F. Lost or Stolen Items

The District maintains a control system that ensures adequate safeguards are in place to prevent loss, damage, or theft of the property.

G. Use of Equipment

Equipment must be used in the program or project for which it was acquired as long as needed, whether or not the project or program continues to be supported by the federal award, and the District will not encumber the property for any non-federal program use without prior approval of the federal awarding agency and the pass-through entity.

H. Disposal of Equipment

When it is determined that original or replacement equipment acquired under a federal award is no longer needed for the original project or program or for

other activities currently or previously supported by a federal awarding agency, the Superintendent or his/her designee will contact the awarding agency (or pass-through for a state-administered grant) for disposition instructions.

If the item has a current FMV of \$5,000 or less, it may be retained, sold, or otherwise disposed of with no further obligation to the federal awarding agency.

V. Other Contract Matters.

A. Required Terms

The non-Federal entity's contracts must contain the applicable provisions required by section 200.326 and described in Appendix II to Part 200—Contract Provisions for non-Federal Entity Contracts Under Federal Awards.

B. Contracting with Certain Vendors

Pursuant to the standards contained in 2 C.F.R. § 200.321, the District will take all necessary affirmative steps to assure that minority businesses, women's business enterprises, and labor surplus area firms are used when possible consistent with state law.

To the maximum extent practicable, the school food program shall purchase domestic commodities or products produced in US or processed in US substantially using agricultural commodities produced in US.

C. Record Keeping

1. Record Retention

- a) The District maintains all records that fully show (1) the amount of funds under the grant or subgrant; (2) how the subgrantee uses those funds; (3) the total cost of each project; (4) the share of the total cost of each project provided from other sources; (5) other records to facilitate an effective audit; and (6) other records to show compliance with federal program requirements. 34 C.F.R. §§ 76.730-.731 and §§ 75.730-.731. The District also maintains records of significant project experiences and results. 34 C.F.R. § 75.732. These records and accounts must be retained and made available for programmatic or financial audit.

- b) The U.S. Department of Education is authorized to recover any federal funds misspent within 5 years before the receipt of a program determination letter. 34 C.F.R. § 81.31(c). Schedule 10 (Local School Districts) and Schedule 24 (Local Agencies General Records) of the Nebraska Records Management Division as approved by the Nebraska Secretary of State/State Records Administrator requires the District to maintain records regarding federal awards for a minimum of six (6) years. Consequently, the District shall retain records for a minimum of six (6) years from the date on which the final Financial Status Report is submitted, unless otherwise notified in writing to extend the retention period by the awarding agency, cognizant agency for audit, oversight agency for audit, or cognizant agency for indirect costs. However, if any litigation, claim, or audit is started before the expiration of the record retention period, the records will be retained until all litigation, claims, or audit findings involving the records have been resolved and final action taken. 2 C.F.R. § 200.333.
- c) Records will be destroyed in compliance with Schedule 10, Schedule 24, and State law. This includes the completion of a Records Disposition Report.

2. Maintenance of Procurement Records

- a) The District must maintain records sufficient to detail the history of all procurements. These records will include, but are not necessarily limited to the following: rationale for the method of procurement, selection of contract type, contractor selection or rejection, the basis for the contract price (including a cost or price analysis), and verification that the contractor is not suspended or debarred.
- b) Retention of procurement records shall be in accordance with applicable law and Board policy.

D. Privacy

The District has protections in place to ensure that the personal information of both students and employees is protected. These include the use of

passwords that are changed on a regular basis; staff training on the requirements of the Family Educational Rights and Privacy Act (FERPA) and State confidentiality requirements; and training on identifying whether an individual requesting access to records has the right to the documentation.

Adopted on: _____

Revised on: _____

Reviewed on: _____



Creating Integrated Solutions Since 1888
www.rochestermidland.com

Water Energy Group
Midwest
Omaha Nebraska
Rep: Ty Lafferty
Cell: 402-613-6373
Tel: 800-388-4762

To: Sterling Public Schools
250 Main St
Sterling, NE 68843

Attn: Steve Logston

We are pleased to quote as follows, your inquiry.

Date 10/26/20

Term Net 30

Prices quoted are

F.O.B. Delivered

Delivery 7 days

QUANTITY	DESCRIPTION	PRICE	AMOUNT
	<u>Chemical Treatment for Cooling Tower</u>		
3 EA	AssetGuard C5224-T 5 gal pail	\$304.54	\$913.62
6 EA	Service Visits	\$125.00	\$750.00
	<u>Total</u>		\$1,663.62

By: Ty Lafferty-Applications Engineer



Creating Integrated Solutions Since 1888
www.rochestermidland.com

Water Energy Group
Midwest
Omaha Nebraska
Rep: Ty Lafferty
Cell: 402-613-6373
Tel: 800-388-4762

To: Sterling Public Schools
250 Main St
Sterling, NE 68843

Attn: Steve Logston

Date 10/27/20

Term Net 30

Prices quoted are

F.O.B. Delivered

Delivery 7 days

We are pleased to quote as follows, your inquiry.

QUANTITY	DESCRIPTION	PRICE	AMOUNT
1 EA	<u>Chemical Treatment for Closed Loop</u> CLT-407	\$340.73	\$340.73
	<u>Total</u>		\$340.73

By: Ty Lafferty-Applications Engineer



Creating Integrated Solutions Since 1888
www.rochestermidland.com

Water Energy Group
Midwest
Omaha Nebraska
Rep: Ty Lafferty
Cell: 402-613-6373
Tel: 800-388-4762

To: Sterling Public Schools
250 Main St
Sterling, NE 68843

Attn: Steve Logston

Date 10/26/20

Term Net 30

Prices quoted are

F.O.B. Delivered

Delivery 7 days

We are pleased to quote as follows, your inquiry.

QUANTITY	DESCRIPTION	PRICE	AMOUNT
	<u>Cooling Tower Cleaning Quote</u>		
1 EA	EQC-18	\$817.37	\$817.37
1 EA	Service Visit	\$125.00	\$125.00
	<u>Total</u>		\$942.37

By: Ty Lafferty-Applications Engineer



Sales Quote

Water Engineering, Inc
 1574 County Rd 10
 PO Box 157
 Mead NE 68041

Date 9/9/2020
 Quote # QUOTE4320

PO #
 Shipping Method Water Engineering
 Ship Date 9/9/2020
 FOB
 Customer Notes
 Project

Bill To
 Stephanie Parde
 Sterling Public Schools
 250 Main Street
 Sterling NE 68443

Ship To
 Sterling Public Schools
 250 Main Street
 Sterling NE 68443

Memo

Equipment/New Pumps and Cleaning

Customer Notes

Item	Quantity	Units	Description	Rate	Amount
EZB11D1-VCA	1	EA	Walchem Metering Pump with Automatic Valve	612.00	612.00
EZB11D1-PE	1	EA	Walchem Pump; 14.4 GPD, 150 psi	504.00	504.00
EZB11D1-PE	1	EA	Walchem Pump; 14.4 GPD, 150 psi	504.00	504.00
Cleaning	1	EA	Tower Cleaning & Sterilization	1,200.00	1,200.00

***PLUS APPLICABLE TAX AND FREIGHT

Subtotal 2,820.00
Shipping Cost (Water Engineering) 60.00
Total \$2,880.00



WATER

engineering inc

Sales Quote

Date 9/9/2020
Quote # QUOTE4322

PO #
Shipping Method Water Engineering
Ship Date 9/9/2020
FOB
Customer Notes
Project

Water Engineering, Inc
1574 County Rd 10
PO Box 157
Mead NE 68041

Bill To

Stephanie Parde
Sterling Public Schools
250 Main Street
Sterling NE 68443

Ship To

Sterling Public Schools
250 Main Street
Sterling NE 68443

Memo

Service Contract

Customer Notes

Item	Quantity	Units	Description	Rate	Amount
Monthly Service Agreement	12	EA	Water Management Service Agreement-Current Month Billing - this contract includes chemicals, testing reagents, and monthly service. Please note: glycol is not included as a chemical for this contract	210.00	2,520.00

***PLUS APPLICABLE TAX AND FREIGHT

Subtotal 2,520.00
Shipping Cost (Water Engineering) 0.00
Total \$2,520.00