

Agenda

1. Mayor Bergman calls meeting to order, with the "Pledge of Allegiance" and the "Open Meeting Statement"
2. Submittal of Requests for Future Agenda Items
3. Reserve Time to Speak on an Agenda Item
4. Mayor Bergman opens two (2) public hearings: (1) Public input on the 2019-2020 Budget. The public hearing was published in the Phonograph Herald on August 7 and August 14, 2019, along with posting the notice in four (4) public places on August 5, 2019 and (2) A new Class I Liquor permit for La Pena Authentic Food (Elvina & Robert Rose) at 515 Howard Avenue. The public hearing was published in the Phonograph Herald on August 7, 2019.
5. Discuss - Approve / Deny the July 2019 Treasurer's Report.
6. Discuss - Approve / Deny Zoning Permits from August 12, 2019.
7. Mayor Bergman opens public comment period regarding public input on the City of St. Paul's 2019-2020 Budget.
 - a. Mayor Bergman closes public comment period.
 - b. Possible action.
8. Mayor Bergman opens public comment period regarding La Pena Authentic Food LLC dba La Pena Authentic Food (Elvina & Robert Rose) Class I-123018 Liquor permit application.
 - a. Mayor Bergman closes public comment period.
 - b. Discuss - Approve / Deny La Pena Authentic Food LLC dba La Pena Authentic Food (Elvina & Robert Rose), 515 Howard Avenue, St. Paul, NE (Howard County) new application for a Class I-123018 Liquor Permit.
9. Discuss - Approve / Deny a street closing on Saturday, October 5, 2019 from 5:00 p.m. to 1:00 a.m. regarding a "Brat's and Booze" social event on 8th Street between Howard Avenue and Grand Street. Fencing will surround the area, with it being attached to the Twin Loup's Quality Meat business. Barricades will be placed in the alley between 7th Street and 8th Street.
10. Discuss - Approve / Deny Loup River Distilling's Special Designated Liquor application (ZK#121705) on Saturday, October 5, 2019 from 5:00 p.m. to 1:00 a.m. for a "Brat's and Booze" social event. The event is located on 8th Street between Howard Avenue and Grand Street. Identification will be checked, along with wristbands being utilized for underage drinking. Fencing will be placed around the perimeter of the area.
11. Discuss - Approve / Deny Michael Coghlan and Tyler Moslander as St. Paul Emergency Medical Technician's (EMT) and Travis Williams as a St. Paul Firefighter.
12. Discuss - Approve / Deny abandoning a 4" water line located between Lot Six (6) and Lot Seven (7), Block Eight-Two (82), Original Town, St. Paul, NE (Elstermeier Greenhouses) and tie into the 8" water main from US Hwy 281 to the perspective businesses and residential owners in the area. The project cost will be absorbed by the

infrastructure fund.

Topic of discussion: a. topographic survey, design, Health & Human Service approval and acquiring a NE Dept. of Transportation permit to perform work on the state right-of-way.

13. Discuss - Approve / Deny Chief of Police Paczosa and Police Officer Coghlan attending the 2019 NSA/POAN NE Law Enforcement Conference on Sunday, October 6 through Wednesday, October 9, 2019 in Kearney, NE.
14. Utility Superintendent Helzer updates
15. Chief of Police Paczosa updates a. Nuisance & Incident Report
16. Council member updates
17. Mayor Bergman updates
18. Public Comment Period - restricted to items on the agenda
19. Public Announcements
20. Closed Session: The City of St. Paul reserves the right to go into Closed Session when it is clearly necessary to protect the public interest or for the prevention of needless injury to the reputation of an individual; or pending litigation
21. Mayor Bergman adjourns City Council meeting.
22. Informational Items:
 - a. 2019 Street Repair List
 - b. Receipt List for July 2019
 - c. Certificate of Deposits for July 2019
 - d. Daily Pool Receipt document that is filled out for each deposit by Ms. Berthelsen

Certificate of Publication

STATE OF NEBRASKA, } ss. \$ 5.60
HOWARD COUNTY }

MICHAEL HAPP

being duly sworn, deposes and says she is the PUBLISHER

of THE PHONOGRAPH-HERALD a legal weekly newspaper under the Statutes of the State of Nebraska, published in Howard County, Nebraska, and of general circulation in said county, and that the annexed notice has been published in the regular and entire issue of every number of The Phonograph-Herald 1 consecutive weeks, the first publication thereof having been made on the 7th day of

August 20 19
[Signature]

Subscribed and sworn to before me this 7th day of August A.D., 20 19

[Signature: Joyce E. Turpitt]
Notary Public

My Commission Expires _____

Printer's Bill:--To publication of above legal notice 18 lines 1 times \$ 5.60

PUBLIC HEARING

A public hearing will be held at 7:00 P.M. on Monday, August 19, 2019 in City Hall at 704 6th Street, St. Paul, NE 68873.

The City Mayor and Councilmembers would like public input/comments on the 2019-2020 Budget.

• Please come to the City of St. Paul Office to get a Preliminary Draft of the 2019-2020 Budget.

Connie Jo Beck,
City Clerk
City of St. Paul
(308) 754-4483

ZNEZ

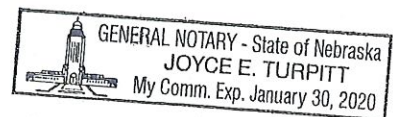

PUBLIC HEARING

A public hearing will be held at 7:00 P.M., on Monday, August 19, 2019 in City Hall at 704 6th Street, St. Paul, NE 68873.

The City Mayor and Councilmembers would like public input / comments on the 2019-2020 Budget.

- **Please come to the City of St. Paul Office to get a Preliminary Draft of the 2019-2020 Budget**

Connie Jo Beck, City Clerk
City of St. Paul
(308)754-4483

- Joyce, please publish in the August 7 and 14, 2019 Phonograph Herald (2 Proofs Please)

Post 8-5-19

Certificate of Publication

STATE OF NEBRASKA, } ss. \$ 6.22
HOWARD COUNTY }

MICHAEL HAPP

being duly sworn, deposes and says she is the
PUBLISHER

of *THE PHONOGRAPH-HERALD* a legal
weekly newspaper under the Statutes of the
State of Nebraska, published in Howard
County, Nebraska, and of general circula-
tion in said county, and that the annexed
notice has been published in the regular and
entire issue of every number of *The
Phonograph-Herald* 1 consecutive
weeks, the first publication thereof having
been made on the 7th day of

August 20 19

Subscribed and sworn to before me this

7th day of August A.D., 20 19

Joyce E. Turpitt
Notary Public

My Commission Expires _____

Printer's Bill:—To publication of above legal
notice 20 lines 1 times \$ 6.22

PUBLIC HEARING
A public meeting will
be held at 7:00 P.M., Mon-
day, August 19, 2019, in
the City Council Chambers
at 704 6th Street, St. Paul,
Nebraska 68873, regarding
a new Class I Liquor Li-
cense application for La
Pena Authentic Food LLC
dba La Pena Authentic
Food (Elvina & Robert J.
Rose) at 515 Howard Av-
enue, St. Paul, Howard
County, Nebraska 68873.
Connie Jo Beck
City Clerk,
Deputy Treasurer
City of St. Paul
DATE: August 5, 2019
ZNEZ

GENERAL NOTARY - State of Nebraska
JOYCE E. TURPITT
My Comm. Exp. January 30, 2020

Treasurer's Report:

<i>Account Number</i>	<i>Prev. Mth Total</i>	<i>Current Mth Total</i>	<i>Total</i>
Homestead Bank	June 30, 2019	July 31, 2019	
Checking 100-027	\$ (764,296.99)	\$ 715,614.63	\$ (48,682.36)
Sales Tax 300-277	\$ (34,146.93)	\$ 18,243.16	\$ (15,903.77)
Civic Center 300-749	\$ (12,836.49)	\$ 9,525.89	\$ (3,310.60)
City REDLG 301-465	\$ (85,144.04)	\$ 90,160.07	\$ 5,016.03
Water Trmt 504-189	\$ (29,006.33)	\$ 29,015.51	\$ 9.18
Keno 504-409	\$ (72,461.66)	\$ 77,820.66	\$ 5,359.00
Sales Tax 504420	\$ (117,680.82)	\$ 91,115.11	\$ (26,565.71)
Pool 504-442	\$ (27,844.95)	\$ 27,853.76	\$ 8.81
Premium General 504-684	\$ (284,847.50)	\$ 285,381.66	\$ 534.16
General 504-805	\$ (28,183.91)	\$ 28,192.83	\$ 8.92
Sewer 504-849	\$ (74,566.78)	\$ 74,593.75	\$ 26.97
Police 504-860	\$ (56,081.02)	\$ 56,101.30	\$ 20.28
Senior Center 504-882	\$ (36,146.06)	\$ 36,157.50	\$ 11.44
Brick (Street) 504-915	\$ (2,019.80)	\$ 2,020.07	\$ 0.27
Library Maint. 504-970	\$ (45,276.56)	\$ 45,290.89	\$ 14.33
Light Sinking 504-981	\$ (23,973.13)	\$ 24,229.69	\$ 256.56
Fire Sinking 504-992	\$ (19,433.17)	\$ 19,438.44	\$ 5.27
EMT Sinking 505-003	\$ (38,842.90)	\$ 38,855.19	\$ 12.29
Street Sinking 505-014	\$ (68,988.11)	\$ 69,013.06	\$ 24.95
Park Sinking 505-025	\$ (44,517.01)	\$ 44,531.10	\$ 14.09
TIF Projects 505-036	\$ (930.29)	\$ 930.42	\$ 0.13
After School 505-146	\$ (3,170.65)	\$ 3,171.08	\$ 0.43
Civic Center Sink 505179	\$ (10,509.83)	\$ 10,512.68	\$ 2.85
Housing Grant 4178-0	\$ (590.55)	\$ 640.55	\$ 50.00
Cemetery Sinking 5413-1	\$ (17,921.44)	\$ 17,921.44	\$ -
Walk/Bike 5482-7	\$ (8,979.98)	\$ 8,979.98	\$ -
Light CD 3212195	\$ (40,986.71)	\$ 40,986.71	\$ -
Water CD 3212196	\$ (31,129.15)	\$ 31,129.15	\$ -
Sewer CD 3212197	\$ (36,317.35)	\$ 36,317.35	\$ -
Sewer CD 3212198	\$ (36,317.35)	\$ 36,317.35	\$ -
General CD 3212199	\$ (39,430.24)	\$ 39,430.24	\$ -
Fire CD 3212200	\$ (23,865.68)	\$ 23,865.68	\$ -
Ambulance CD 3212201	\$ (51,363.10)	\$ 51,363.10	\$ -
Park CD 3212202	\$ (41,505.53)	\$ 41,505.53	\$ -
General CD 3051705	\$ (217,495.26)	\$ 218,417.08	\$ 921.82
Sales Tax CD 3327564	\$ (78,535.56)	\$ 78,862.55	\$ 326.99
Light CD 3640996	\$ (43,413.42)	\$ 43,413.42	\$ -

General CD 3212279	\$	(150,463.16)	\$	150,463.16	\$	-
Citizens Bank						
Consumer Deposit 102-415	\$	(47,327.50)	\$	47,327.50	\$	-
Cafeteria 125 102-407	\$	(18,397.10)	\$	16,852.03	\$	(1,545.07)
Health Ded 102-482	\$	(81,406.86)	\$	80,297.87	\$	(1,108.99)
Cemetery Saving 753-122	\$	(16,302.09)	\$	40,704.19	\$	24,402.10
Park Aluminum 772682	\$	-	\$	1,137.22	\$	1,137.22
25% Infrastructure 102-342	\$	(219,648.31)	\$	225,965.42	\$	6,317.11
Light ICS 103217	\$	(306,270.71)	\$	444,545.57	\$	138,274.86
Water ICS 103225	\$	(59,342.59)	\$	87,001.76	\$	27,659.17
Sewer ICS 103241	\$	(149,353.71)	\$	149,683.86	\$	330.15
General ICS 103209	\$	(274,652.13)	\$	275,259.25	\$	607.12
Building ICS 103233	\$	(47,141.44)	\$	47,245.64	\$	104.20
Fire ICS 103268	\$	(107,267.26)	\$	107,527.20	\$	259.94
Ambulance ICS 103276	\$	(199,630.40)	\$	200,114.18	\$	483.78
Park ICS 103284 (Batting Cage)	\$	(69,110.60)	\$	69,263.37	\$	152.77
Police ICS 103292	\$	(20,236.40)	\$	20,281.13	\$	44.73
Keno ICS 103314	\$	(64,756.58)	\$	64,899.72	\$	143.14
General TCD 109366	\$	(56,254.00)	\$	56,254.00	\$	-
General TCD 109367	\$	(56,243.85)	\$	56,243.85	\$	-
Heritage Bank						
UB ACH 411025	\$	(822,058.40)	\$	901,316.38	\$	79,257.98
Investors 4100744	\$	(258,005.85)	\$	258,049.68	\$	43.83
CITY FUND TOTAL	\$	(5,572,625.19)	\$	5,767,351.56	\$	194,726.37

Deposits and Checks printed for Month (held in statement folder)

2018-2019

Month / Year	Deposit Total	Check Total	Grand Total
October 31, 2018	\$ 450,148.91	\$ (478,765.10)	\$ (28,616.19)
November 30, 2018	\$ 346,651.06	\$ (381,872.93)	\$ (35,221.87)
December 31, 2018	\$ 406,785.65	\$ (482,289.47)	\$ (75,503.82)
January 31, 2019	\$ 463,437.50	\$ (361,610.01)	\$ 101,827.49
February 28, 2019	\$ 431,110.45	\$ (356,041.59)	\$ 75,068.86
March 31, 2019	\$ 441,032.74	\$ (497,911.28)	\$ (56,878.54)
April 30, 2019	\$ 436,406.35	\$ (381,133.73)	\$ 55,272.62
May 31, 2019	\$ 672,774.24	\$ (621,986.99)	\$ 50,787.25
June 30, 2019	\$ 454,547.11	\$ (481,837.57)	\$ (27,290.46)
July 31, 2019	\$ 413,686.78	\$ (383,111.16)	\$ 30,575.62
August 31, 2019			\$ -
September 30, 2019			\$ -
Grand Total	\$ 4,516,580.79	\$ (4,426,559.83)	\$ 90,020.96
Deposit & Checks Monthly Total (Shared)			

St. Paul Planning Commission

August 12, 2019

Meeting Minutes

A meeting of the St. Paul Planning Commission was convened in open and public session on the 12th day of August, 2019 at 12:00 p.m. (noon) in the City Council Chambers, 704 6th Street, St. Paul, Nebraska.

Planning Secretary Berthelsen called the meeting to order at 12:03 p.m. with a statement regarding the Open Meeting Act, which is posted on the west wall of the City Council Chambers. The agenda was sent to the Commission members prior to the meeting and posted in four (4) public places. Commission members present: Connie Becker, Arvilla Jacobs, and Tony Walch. Absent: Chuck Schmid and Wilber Medbery. Also present Zoning Administrator Matt Helzer and Laura Berthelsen (minutes).

Commission member Becker moved to approve the July 29, 2019 meeting minutes. Commission member Jacobs seconded the motion. Roll call vote of Commission members: Becker, Jacobs, and Walch voted aye, nays none. Motion carried 3/0.

The following zoning permits were presented:

- (a) 2019-45 Stephanie Holdsworth – Install replacement fence at 1217 Elm Street
- (b) 2019-46 Brian & Catey Sack – Install replacement fence at 1104 7th Street
- (c) 2019-47 Bill & Karen Northup – Install fence at 922 Indian Street
- (d) 2019-48 Levander's Body Shop – Construct building at 321 Elm Street
- (e) 2019-49 Glenn Jares – Construct gazebo & deck extension at 422 6th Street
- (f) 2019-50 Douglas & Pamela Ackles – Construction of handicap accessible ramp at 1705 Custer Street
- (g) 2019-51 Margaret Thompson – Demolition of barn at 1604 Paul Street

Commission member Jacobs moved to approve Zoning Permit applications 2019-45 and 2019-51. Commission member Becker seconded the motion. Roll call vote of Commission members: Becker, Jacobs, and Walch voted aye, nays none. Motion carried 3/0.

It was noted that the legal description for Rice's Subdivision had some errors that needed to be corrected. The agenda item will be moved to the August 26, 2019 Planning Commission meeting to allow time for the surveyor to provide corrected documents, and for the property owners to sign the documents.

The next St. Paul Planning Commission meeting will be held on Monday, August 26, 2019 at 7:00 p.m.

The meeting was adjourned the meeting at 12:15 p.m.

Sincerely,

Matthew T. Helzer
Zoning Administrator

Charles M. Schmid
Chairman

Laura Berthelsen
Planning Secretary

Zoning Classification R2 Value \$ ¹⁵⁰⁰ ~~0000~~

PERMIT NUMBER 2019-45
FEE \$25.00 CASH CHECK# 1610 CC

APPLICATION FOR A FENCE PERMIT

St. Paul, Nebraska: DIRECTIONS: Fill in the following information as accurately and completely as possible. This application is not acceptable unless all required information is furnished.

Property Owner Stephanie Holdsworth Contractor American Fence Company

Address 1217 Elm Street Address 1605 N Shady Bend Rd

City, State, Zip St Paul NE 68873 Phone Number 308 395 0793

Phone Number 402 309 0935 Cell Phone _____

Complete Legal Description of the Property Lot 5 + E 1/2 of Lot 6, Block 13, Military Add.

Address of Fence Site 1217 Elm Street Size & Kind White vinyl 6' privacy

Replacement or New Fence: replacement

Approximately when will the construction: Start 8/17/19 Finish 8/25/19

To Whom Should the Improvements be assessed? Stephanie Holdsworth

Contact Utility Superintendent at (308) 754-4483 regarding Inspection Matt Helzer Date of visit 8-8-19
(Matt Helzer's signature)

Recommendations needed before approval: _____

MUST CALL DIGGERS HOTLINE @ 811 BEFORE DIGGING - CONSTRUCTION ON UTILITY EASEMENTS IS NOT PERMITTED. The above information is, to the best of my knowledge, true and accurate. It is understood and agreed that any error, misstatement or misrepresentation of fact, either with or without intention on my part, such as might, if known, cause a refusal of this application, or any alteration or change in plans made without the approval of the Zoning Administrator subsequent to the issuance of the Permit, shall constitute sufficient grounds for the revocation of such permit. This permit is valid for one (1) year from approval date.

The signature also indicates permission granted to the Zoning Administrator to inspect the site in which this permit is granted at any time until completed.

Signature of Applicant [Signature] Date 8/16/19

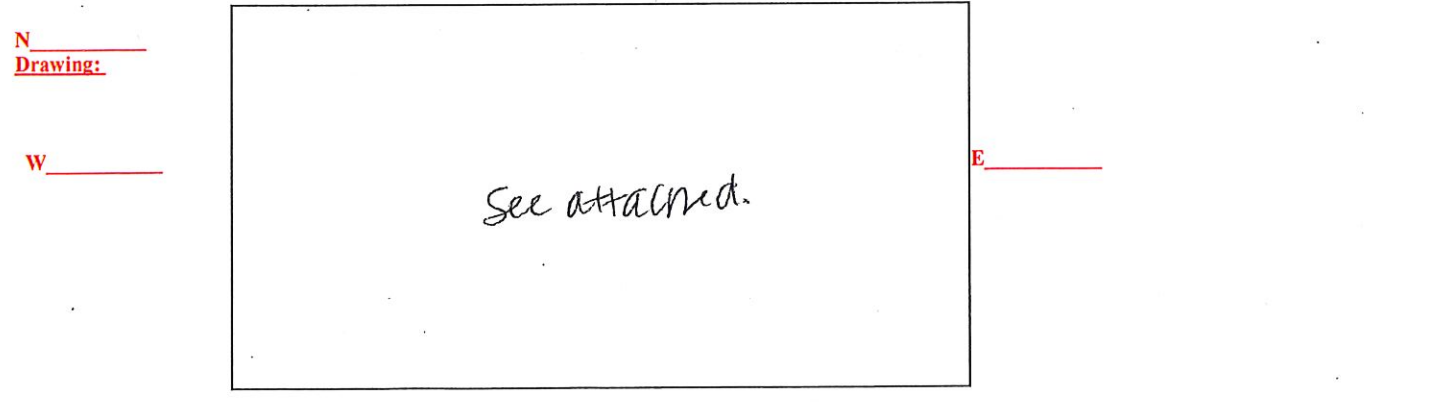

For Office Use Only: Permit is Approved Denied S _____ Date _____
Zoning Administrator

Reasons for Denial: _____

2019-45

AMERICAN FENCE COMPANY



Omaha Lincoln Des Moines Sioux Falls Grand Island Kansas City Rochester
1605 North Shady Bend Road Office: (308) 395-0793 SALESMAN
Grand Island, NE 68801 Email: c.hancock@americafence.com Phone: 308-379-0666

DATE: 7/3/2019	PHONE: 402-309-9935	CELL:	Kingston 424@gmail.com
CUSTOMER: Catey Sack	WORK:	SPECIFICATION FOR FENCE - RAILINGS	
PROJECT LOCATION: 1217 Elm Street	STYLE DRAWING: K 373	STYLE DRAWING:	
CITY: St. Paul STATE: NE ZIP: 68873	OVERALL LENGTH: 91'	OVERALL HEIGHT: 6'	
BILLING ADDRESS:	AFC JOB #:		
CITY: STATE: NE ZIP:			

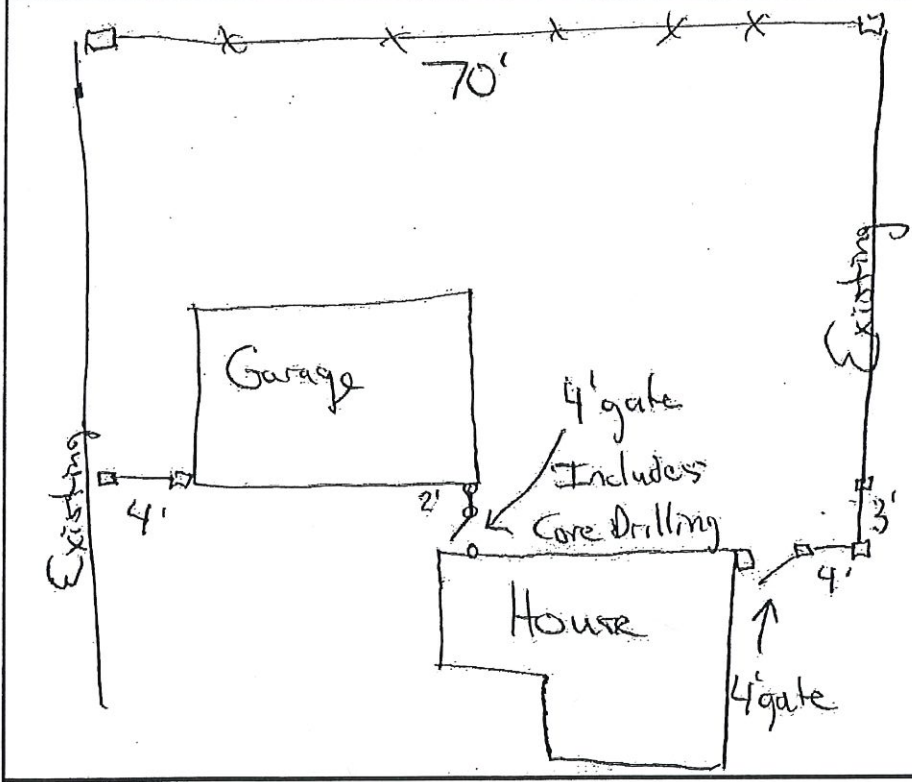

EMAIL: _____
SPECIAL NOTES:
Materials, Labor, & Tax all included. The posts are set using concrete.

- CORNER LOT
- FRENCH GOTHIC
- REPAIR
- OVER SCALLOP
- CUSTOM WOOD
- UNDER SCALLOP
- CUSTOM METAL
- CEDAR POST

GATE INFORMATION

#1:	4'	<input type="checkbox"/> SS	<input type="checkbox"/> DD
#2:	4'	<input type="checkbox"/> SS	<input type="checkbox"/> DD
#3:		<input type="checkbox"/> SS	<input type="checkbox"/> DD
#4:		<input type="checkbox"/> SS	<input type="checkbox"/> DD

FENCE #1: _____
FENCE #2: _____
PERMIT: NA

OPTIONAL ITEMS BELOW ARE NOT INCLUDED IN FENCE PRICE

- TEAR OUT
- HAND DIGS
- SURVEY
- SPRINKLER INS. Optional
- DIRT REMOVAL Optional

OPTIONAL ITEMS SUB TOTAL: _____
TOTAL: _____
QUOTE IS GOOD FOR 15 DAYS

Description:
Provide & install 6' tall white vinyl fence per drawing above. Price includes tax, material and labor.

Includes Removal of clothes line posts \$6755⁰⁰

AFC REPRESENTATIVE: Chad Hancock	DATE: 5/2/2019	OFFICE USE ONLY	DATE: _____
CUSTOMER SIGNATURE: _____	DATE: _____		TYPE: _____
			AMOUNT: _____

421 Sheridan (Jannlewicz) - Okay to attach their fence to ours
1223 Elm (Sonney) -

2019-45



A Special Note

8/6/19

OK to attach to our fence.
will use a separation spacer
in between attachment to
indicate division of property that
belongs to owners of 1223 Elm Street.

GORDON A. SENNEY

Audrey Senney
08/06/19

Zoning Classification A-2 Value \$ 1500 PERMIT NUMBER 2019-46
FEE \$25.00 CASH CHECK# 1611 CC

APPLICATION FOR A FENCE PERMIT

St. Paul, Nebraska: DIRECTIONS: Fill in the following information as accurately and completely as possible. This application is not acceptable unless all required information is furnished.

Property Owner Brian Sack and Cathryn Sack Contractor American Fence Company

Address 1104 7th Street Address 1105 N Shady Bend Rd

City, State, Zip St Paul NE 68873 Phone Number 308 395 0793

Phone Number 402 309 0935 Cell Phone

Complete Legal Description of the Property LOT 7 BLOCK 4 OF ST PAUL

Address of Fence Site 1104 7th Street Size & Kind white vinyl w' privacy

Replacement or New Fence: replacement along 2 rear sides & front side (south)
4" whopching

Approximately when will the construction: Start 8/17/19 Finish 8/25/19

To Whom Should the Improvements be assessed? Brian Sack and Cathryn Sack

Contact Utility Superintendent at (308) 754-4483 regarding Inspection Matt Helzer Date of visit 8-7-19
(Matt Helzer's signature)

Recommendations needed before approval:

MUST CALL DIGGERS HOTLINE @ 811 BEFORE DIGGING – CONSTRUCTION ON UTILITY EASEMENTS IS NOT PERMITTED. The above information is, to the best of my knowledge, true and accurate. It is understood and agreed that any error, misstatement or misrepresentation of fact, either with or without intention on my part, such as might, if known, cause a refusal of this application, or any alteration or change in plans made without the approval of the Zoning Administrator subsequent to the issuance of the Permit, shall constitute sufficient grounds for the revocation of such permit. This permit is valid for one (1) year from approval date.

The signature also indicates permission granted to the Zoning Administrator to inspect the site in which this permit is granted at any time until completed.

Signature of Applicant [Signature] Date 8-6-19

N 6"
Drawing:

W 85'



For Office Use Only: Permit is Approved Denied S 2' Date
Zoning Administrator

Reasons for Denial:

2019-46

AMERICAN FENCE COMPANY

Omaha Lincoln Des Moines Sioux Falls Grand Island Kansas City Rochester
 1605 North Shady Bend Road Office: (308) 395-0793 SALESMAN *Chad Hancock*
 Grand Island, NE 68801 Email: c.hancock@americafence.com Phone: 308-379-0666

DATE: <u>7/3/2019</u>	PHONE: <u>402-309-9935</u>	CELL:
CUSTOMER: <u>Catey Sack</u>	WORK:	SPECIFICATION FOR FENCE - RAILINGS
PROJECT LOCATION: <u>1104 7th Street</u>	STYLE DRAWING: <u>K 373</u>	STYLE DRAWING:
CITY: <u>St Paul</u> STATE: <u>NE</u> ZIP: <u>68873</u>	OVERALL LENGTH: <u>156'</u>	OVERALL HEIGHT: <u>6'</u>
BILLING ADDRESS:	AFC JOB #:	
CITY:	STATE: <u>NE</u> ZIP:	

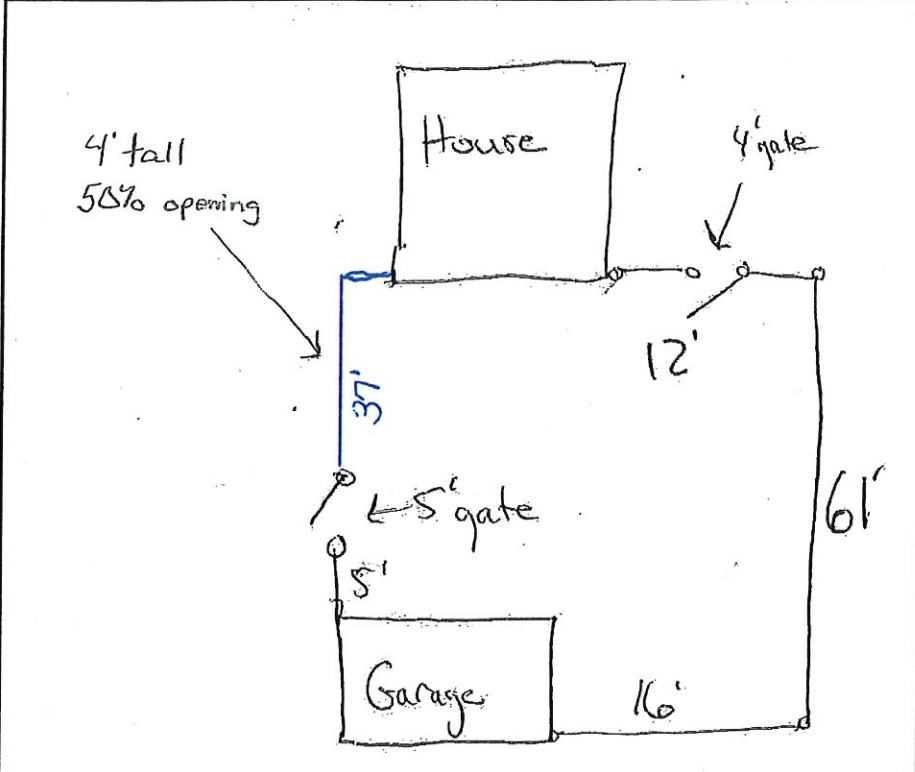

Description:
 Provide & install 6" solid vinyl fence per drawing. White in color. Prices include tax, material & labor.

EMAIL:

SPECIAL NOTES:
 Materials, Labor, & Tax all included. The posts are set using concrete.

CORNER LOT FRENCH GOTHIC
 REPAIR OVER SCALLOP
 CUSTOM WOOD UNDER SCALLOP
 CUSTOM METAL CEDAR POST

GATE INFORMATION

#1:	<u>4'</u>	<input checked="" type="checkbox"/> SS	<input type="checkbox"/> DD
#2:	<u>5'</u>	<input checked="" type="checkbox"/> SS	<input type="checkbox"/> DD
#3:		<input type="checkbox"/> SS	<input type="checkbox"/> DD
#4:		<input type="checkbox"/> SS	<input type="checkbox"/> DD

FENCE #1: _____
 FENCE #2: _____
 PERMIT: By Owner

OPTIONAL ITEMS BELOW ARE NOT INCLUDED IN FENCE PRICE

TEAR OUT
 HAND DIGS
 SURVEY
 SPRINKLER INS: _____ Optional
 DIRT REMOVAL: _____ Optional

OPTIONAL ITEMS SUB TOTAL: _____
 TOTAL: _____

QUOTE IS GOOD FOR 15 DAYS

AFC REPRESENTATIVE: <u>Chad Hancock</u>	DATE: <u>5/2/2019</u>	OFFICE USE ONLY	DATE: _____
CUSTOMER SIGNATURE: _____	DATE: _____		TYPE: _____
			AMOUNT: _____

Zoning Classification R-2

Value \$ 400.00

PERMIT NUMBER 2019-47
FEE \$25.00 CASH CHECK# 2330 CC

APPLICATION FOR A FENCE PERMIT

St. Paul, Nebraska: DIRECTIONS: Fill in the following information as accurately and completely as possible. This application is not acceptable unless all required information is furnished.

Property Owner Bill + Karen Northrup Contractor Self

Address 922 Indian Street Address _____

City, State, Zip St. Paul, NE 68873 Phone Number _____

Phone Number 308-571-0041 Cell Phone _____

Complete Legal Description of the Property Lot 7 + W38' of Lot 8 Block 6 Bartletts Add St. Paul

Address of Fence Site 922 Indian Street Size & Kind 6' wood fence

Replacement or New Fence: Add to existing fence Approx. 24'

Approximately when will the construction: Start Aug 2019 Finish Sept 2019

To Whom Should the Improvements be assessed? _____

Contact Utility Superintendent at (308) 754-4483 regarding inspection Matt Helzer Date of visit 8-8-19
(Matt Helzer's signature)

Recommendations needed before approval: _____

MUST CALL DIGGERS HOTLINE @ 811 BEFORE DIGGING – CONSTRUCTION ON UTILITY EASEMENTS IS NOT PERMITTED. The above information is, to the best of my knowledge, true and accurate. It is understood and agreed that any error, misstatement or misrepresentation of fact, either with or without intention on my part, such as might, if known, cause a refusal of this application, or any alteration or change in plans made without the approval of the Zoning Administrator subsequent to the issuance of the Permit, shall constitute sufficient grounds for the revocation of such permit. This permit is valid for one (1) year from approval date.

The signature also indicates permission granted to the Zoning Administrator to inspect the site in which this permit is granted at any time until completed.

Signature of Applicant Bill Northrup Date _____

N 75'
Drawing:

W 63'

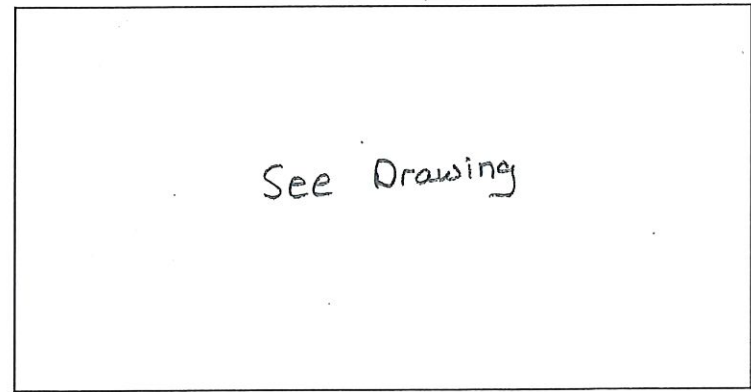

E 6''

For Office Use Only: Permit is Approved Denied S 57' Date _____

Zoning Administrator

Reasons for Denial: _____

2019-47

North ↑

urrent Move: L2/U8

Parcel # 470998357

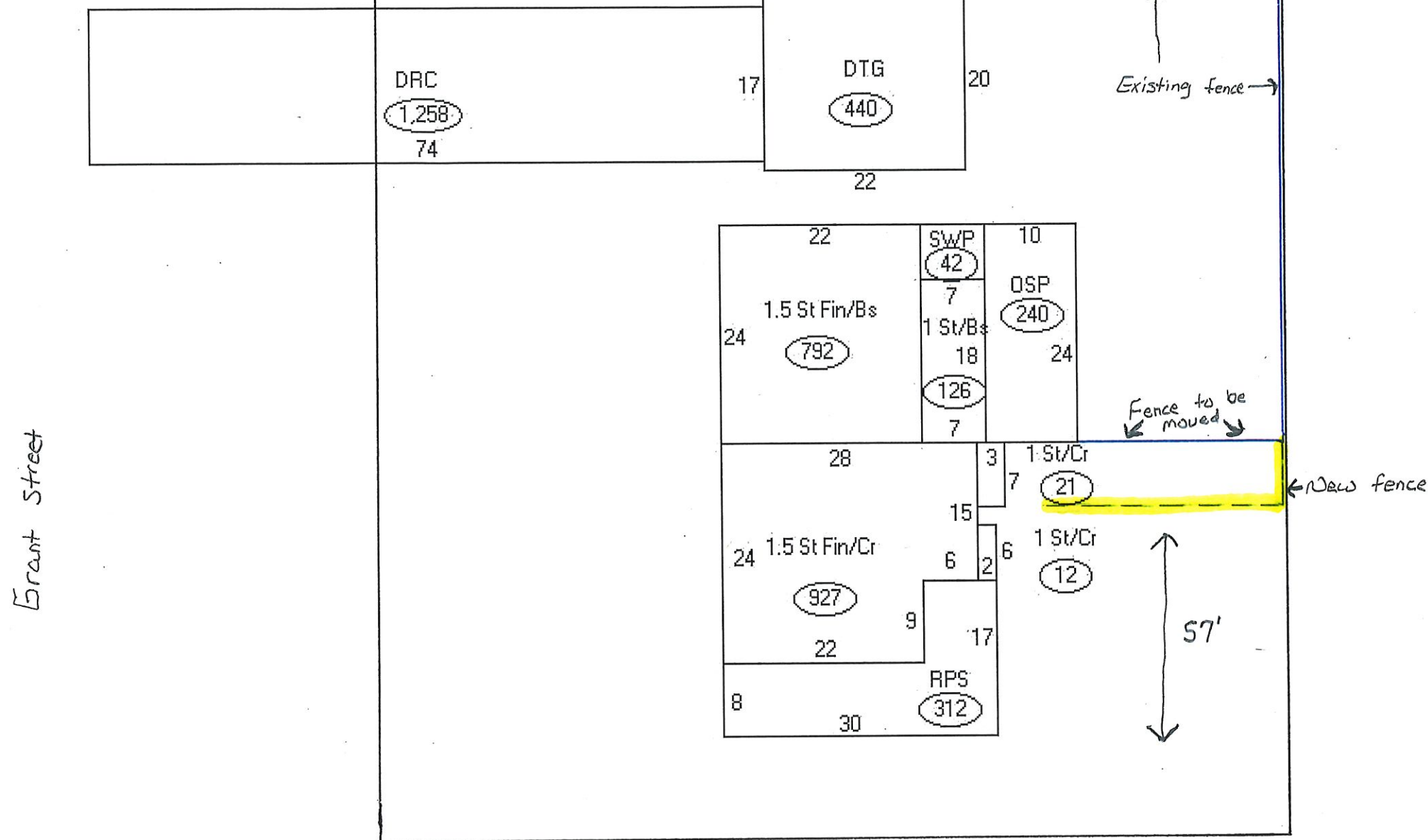

Zoning Classification Light Industrial Value \$ 58,000
Please call 811 Diggers Hotline before designing

PERMIT NUMBER 2019-48
FEE \$ 100.00 CASH CHECK# _____ 8/9/19

APPLICATION FOR A COMMERCIAL ZONING PERMIT

St. Paul, Nebraska: DIRECTIONS: Fill in the following information as accurately and completely as possible. This application is not acceptable unless all requirement information is furnished.

Property Owner Jevandei Body shop Brian Jevander Contractor B Jevanders construction
Address NEW? Address 1509 Indian St St Paul NE
City, State, Zip St Paul NE 68873 ^{Grand Island NE 68803} Phone Number _____
Phone Number 308 390 6494 Cell Phone 308 750 3335

Complete Legal Description of the Property _____

Address of Construction Site 323 Elm St St Paul NE 68873
(If none, one must be registered with City of St. Paul or the 911 center.) In the Flood Plain NO?

Proposed Structure & Use auto break down + prep Dimension of Structure 30x56

Distance from Front property line ^{North} 109' Plans Submitted to Fire Marshall Office Yes

Rear Property Line ^{South} 11 ft Side Property Line ^{West} 26 ft ^{East} Second Side Line 76' Between other buildings (Min 10') 11 ft

Is there a utility easement on either the back or side property? _____ If so attach a copy of neighbor approval.

Approximately when will construction Start Aug 28th/ Sep 1st Finish By Oct 30th

To Whom Should the Improvements be assessed? Jevanders Body Shop

Contact Utility Superintendent at (308) 754-4483 regarding Set-Back Inspection. Matt Helzer Date of visit 8-9-19
(Matt Helzer's signature)

Recommendations needed before approval: _____

(One Mile radius outside city limits) If the structure is a residence on less than 10 acres indicate the date this property was platted as a separate parcel _____ and the Name of the Lot Split or Subdivision, _____

For Office Use Only:
Is the proposed use permitted within this zoning district? YES _____ NO _____
Does the proposed use meet all the required setback distances? YES _____ NO _____
Is a conditional use required for the proposed use? _____ YES NO _____
Has a Conditional Use Permit been issued for this proposed use? _____ YES NO _____
If yes, when does it expire? _____

PERMIT NUMBER 2019-48

Site Plan Sketch:

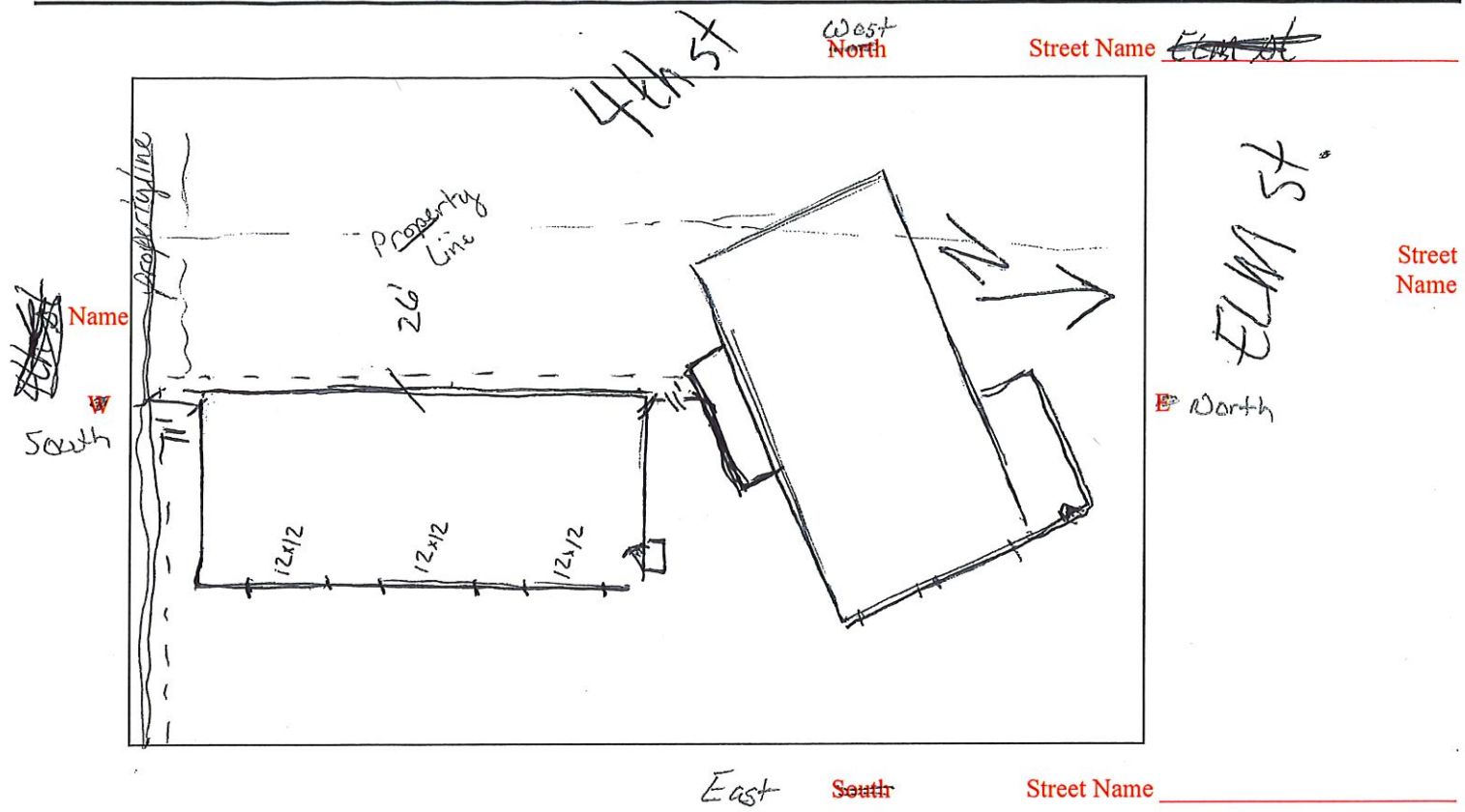

Indicate, by drawing, the shape and dimensions of the land, shape and dimensions of all existing and proposed building and structures and the distances from the proposed building and structures to all lot lines (from road frontages, side and rear lot lines). Show the location of roads fronting the property. **MUST CALL DIGGERS HOTLINE @ 811 BEFORE DIGGING – CONSTRUCTION ON UTILITY EASEMENTS IS NOT PERMITTED. NEW CONSTRUCTION MUST CALL Electrical Inspector, Kim Farnstrom 308-728-7612**

The above information is, to the best of my knowledge, true and accurate. It is understood and agreed that any error, misstatement or misrepresentation of fact, either with or without intention on my part, such as might, if known, cause a refusal of this application, or any alteration or change in plans made without the approval of the Zoning Administrator subsequent to the issuance of the Permit, shall constitute sufficient grounds for the revocation of such permit. This permit is valid for one (1) year from approval date and work must be started within the first 6 months.

The signature also indicates permission granted to the Zoning Administrator to inspect the construction site in which this permit is granted at any time until construction is completed and a Certificate of Occupancy is issued.

Signature of Applicant Quentin Levander Date August 9/2019

For Office Use Only:

Permit is Approved _____ Denied _____ Date _____
Zoning Administrator

Reasons for Denial:

City of St. Paul Zoning Administrator
704 6th St, St. Paul, NE 68873
Phone 308-754-4483, e-mail: mhelzer@cityofstpaulne.org

Zoning Classification R-3 Value \$ 5,000
Please call 811 before completing form

PERMIT NUMBER 2019-49
FEE \$ 25.00 CASH CHECK# 1373

APPLICATION FOR A RESIDENTIAL ZONING PERMIT

St. Paul, Nebraska: DIRECTIONS: Fill in the following information as accurately and completely as possible. This application is not acceptable unless all requirement information is furnished.

Property Owner Glenn James Contractor John Halinsky

Address 424 N. Sherman Ave. Address _____

City, State, Zip Grand Island, NE. 68803 Phone Number _____

Phone Number (308) 381-0540 Cell Phone 308 745-5656

Complete Legal Description of the Property Lots 17 and 18 Block 30 OT St. Paul

Address of Construction Site 422 6th Street, St. Paul
(If none, one must be registered with City of St. Paul) In the Flood plain NO?

Proposed Structure Eazebo + deck extension Dimension of Structure 12' Octagon

Distance from Front property line 30' 6"

Rear Property Line 45' 6" ^{South} Side Property Line 42' ^{East} Second Side Line 78' ^{West} Between other buildings (Min 10') 24'

Is there a utility easement on either the back or side property? NO If so attach a copy of neighbor approval.

Approximately when will construction Start Aug 2019 Finish Aug 2020

To Whom Should the Improvements be assessed? _____

Contact Utility Superintendent at (308) 754-4483 regarding Set-Back Inspection. Matt Helzer Date of visit 8-9-19
(Matt Helzer's signature)

Recommendations needed before approval: _____

(One Mile radius outside city limits) If the structure is a residence on less than 10 acres indicate the date this property was platted as a separate parcel _____ and the Name of the Lot Split or Subdivision, _____

For Office Use Only:

Is the proposed use permitted within this zoning district? _____ YES _____ NO

Does the proposed use meet all the required setback distances? _____ YES _____ NO

Is a conditional use required for the proposed use? _____ YES _____ NO

Has a Conditional Use Permit been issued for this proposed use? _____ YES _____ NO
If yes, when does it expire? _____

PERMIT NUMBER 2019-49

Site Plan Sketch:

North Street Name Elm

Street Name
Sixth

Street Name
Fifth

W

E

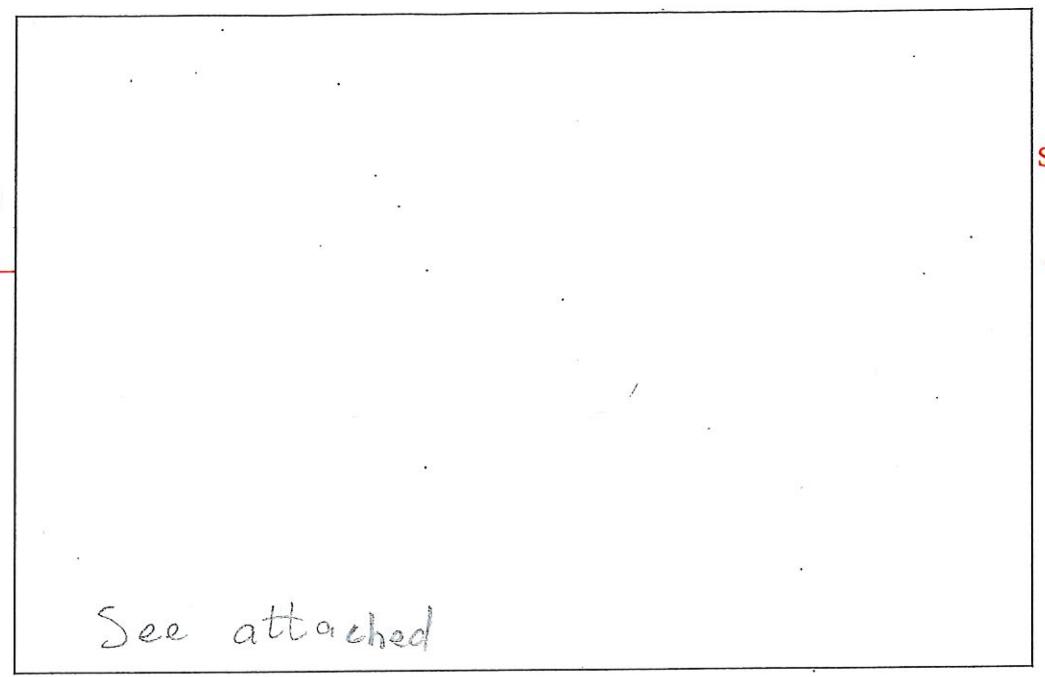

South Street Name Davis

Indicate, by drawing, the shape and dimensions of the land, shape and dimensions of all existing and proposed building and structures and the distances from the proposed building and structures to all lot lines (from road frontages, side and rear lot lines). Show the location of roads fronting the property. **MUST CALL DIGGERS HOTLINE @ 811 BEFORE DIGGING - CONSTRUCTION ON UTILITY EASEMENTS IS NOT PERMITTED. NEW HOMES MUST CALL ELECTRICAL INSPECTOR, Kim Farnstrom 308-728-7612**

The above information is, to the best of my knowledge, true and accurate. It is understood and agreed that any error, misstatement or misrepresentation of fact, either with or without intention on my part, such as might, if known, cause a refusal of this application, or any alteration or change in plans made without the approval of the Zoning Administrator subsequent to the issuance of the Permit, shall constitute sufficient grounds for the revocation of such permit. This permit is valid for one (1) year from approval date and work must be started within the first 6 months.

The signature also indicates permission granted to the Zoning Administrator to inspect the construction site in which this permit is granted at any time until construction is completed and a Certificate of Occupancy is issued.

Signature of Applicant *Allen Jones* Date 7/25/2019

For Office Use Only:

Permit is Approved _____ Denied _____ Date _____
Zoning Administrator

Reasons for Denial:



1-800-700-1777

Design Your Own

Gazebos

Party & Bar

Pavilions

Commercial

« Back to Main Menu



Your Gazebo is Complete!

Call us today at **1-800-700-1777** to speak with a gazebo designer.

Product Basics

Type: Gazebo
 Shape: Octagon
 Material: Vinyl
 Size: 12 ft

Customization Options

Roof: Majestic
 Cornice: Straight
 Posts: Turned
 Braces: Standard

Colors

Color: White Vinyl
 Roof: Earthtone Cedar
 Floorboard: No Deck

Enclosures

Screens: Screen Package

Accessories

Electrical Package: 1
 Additional Outlets: 0
 Ceiling Fan: None
 Wall Mounted Heater: 0
 Weathervane: No
 Benches: 0
 Patio Set: None

2019-49

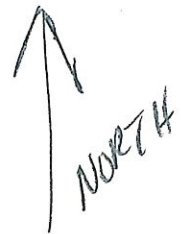

Elm Street

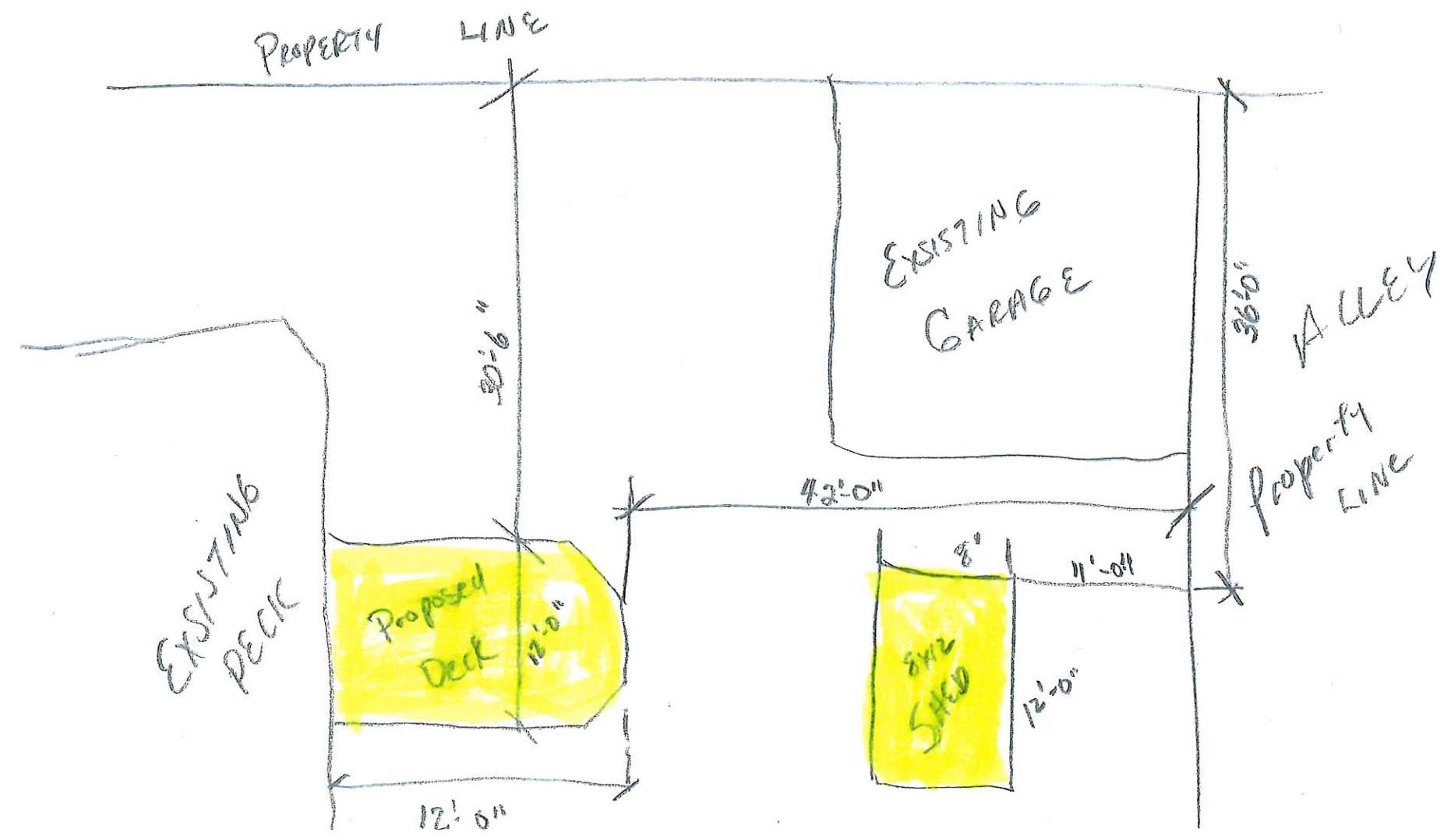

Zoning Classification R-1 Value \$ 1500.⁰⁰
Please call 811 before completing form

PERMIT NUMBER 2019-50
FEE \$ 25.⁰⁰ CASH CHECK#

APPLICATION FOR A RESIDENTIAL ZONING PERMIT

St. Paul, Nebraska: DIRECTIONS: Fill in the following information as accurately and completely as possible. This application is not acceptable unless all requirement information is furnished.

Property Owner Douglas + Pamela Ackles Contractor Eordy Christensen

Address 1705 Custer Street Address 122 Sheridan Street

City, State, Zip St Paul, NE 68873 Phone Number

Phone Number Cell Phone 308-750-1130

Complete Legal Description of the Property Lots 52 + 53 Kelly's First Add St. Paul

Address of Construction Site 1705 Custer Street
(If none, one must be registered with City of St. Paul) In the Flood plain NO?

Proposed Structure Wood Handicap Ramp Dimension of Structure 4' x 38'

Distance from ^{North} Front property line 51'

Rear Property Line ^{South} 60' ^{East} Side Property Line 21' ^{West} Second Side Line 87' Between other buildings (Min 10')

Is there a utility easement on either the back or side property? YES If so attach a copy of neighbor approval.

Approximately when will construction Start Aug 2019 Finish Sept. 2019

To Whom Should the Improvements be assessed? Doug + Pam Ackles

Contact Utility Superintendent at (308) 754-4483 regarding Set-Back Inspection. Matt Helzer Date of visit 8-9-19
(Matt Helzer's signature)

Recommendations needed before approval: Article 9.1.03 - 2A

(One Mile radius outside city limits) If the structure is a residence on less than 10 acres indicate the date this property was platted as a separate parcel and the Name of the Lot Split or Subdivision,

For Office Use Only:

Is the proposed use permitted within this zoning district? YES NO

Does the proposed use meet all the required setback distances? YES NO

Is a conditional use required for the proposed use? YES NO

Has a Conditional Use Permit been issued for this proposed use? YES NO
If yes, when does it expire?

Site Plan Sketch:

North Street Name _____

Street Name

Street Name

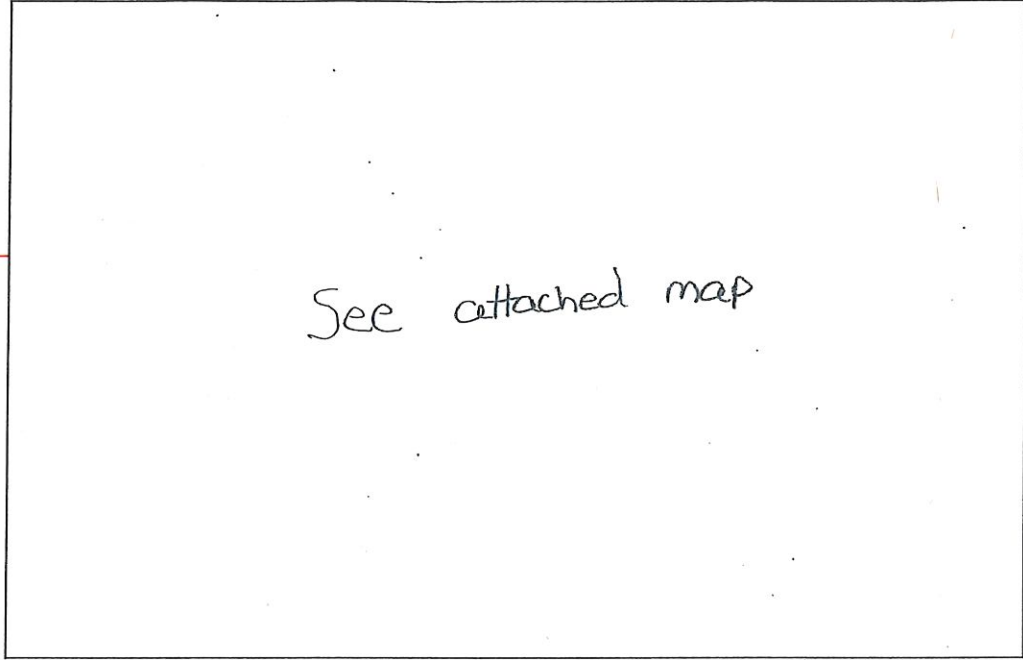

W

E

South Street Name _____

Indicate, by drawing, the shape and dimensions of the land, shape and dimensions of all existing and proposed building and structures and the distances from the proposed building and structures to all lot lines (from road frontages, side and rear lot lines). Show the location of roads fronting the property. **MUST CALL DIGGERS HOTLINE @ 811 BEFORE DIGGING - CONSTRUCTION ON UTILITY EASEMENTS IS NOT PERMITTED. NEW HOMES MUST CALL ELECTRICAL INSPECTOR, Kim Farnstrom 308-728-7612**

The above information is, to the best of my knowledge, true and accurate. It is understood and agreed that any error, misstatement or misrepresentation of fact, either with or without intention on my part, such as might, if known, cause a refusal of this application, or any alteration or change in plans made without the approval of the Zoning Administrator subsequent to the issuance of the Permit, shall constitute sufficient grounds for the revocation of such permit. This permit is valid for one (1) year from approval date and work must be started within the first 6 months.

The signature also indicates permission granted to the Zoning Administrator to inspect the construction site in which this permit is granted at any time until construction is completed and a Certificate of Occupancy is issued.

Signature of Applicant *Sandy Christen* Date 8/9/19

For Office Use Only:

Permit is Approved _____ Denied _____ Date _____
 Zoning Administrator

Reasons for Denial:

2019-50

Kelly Street

Property Line

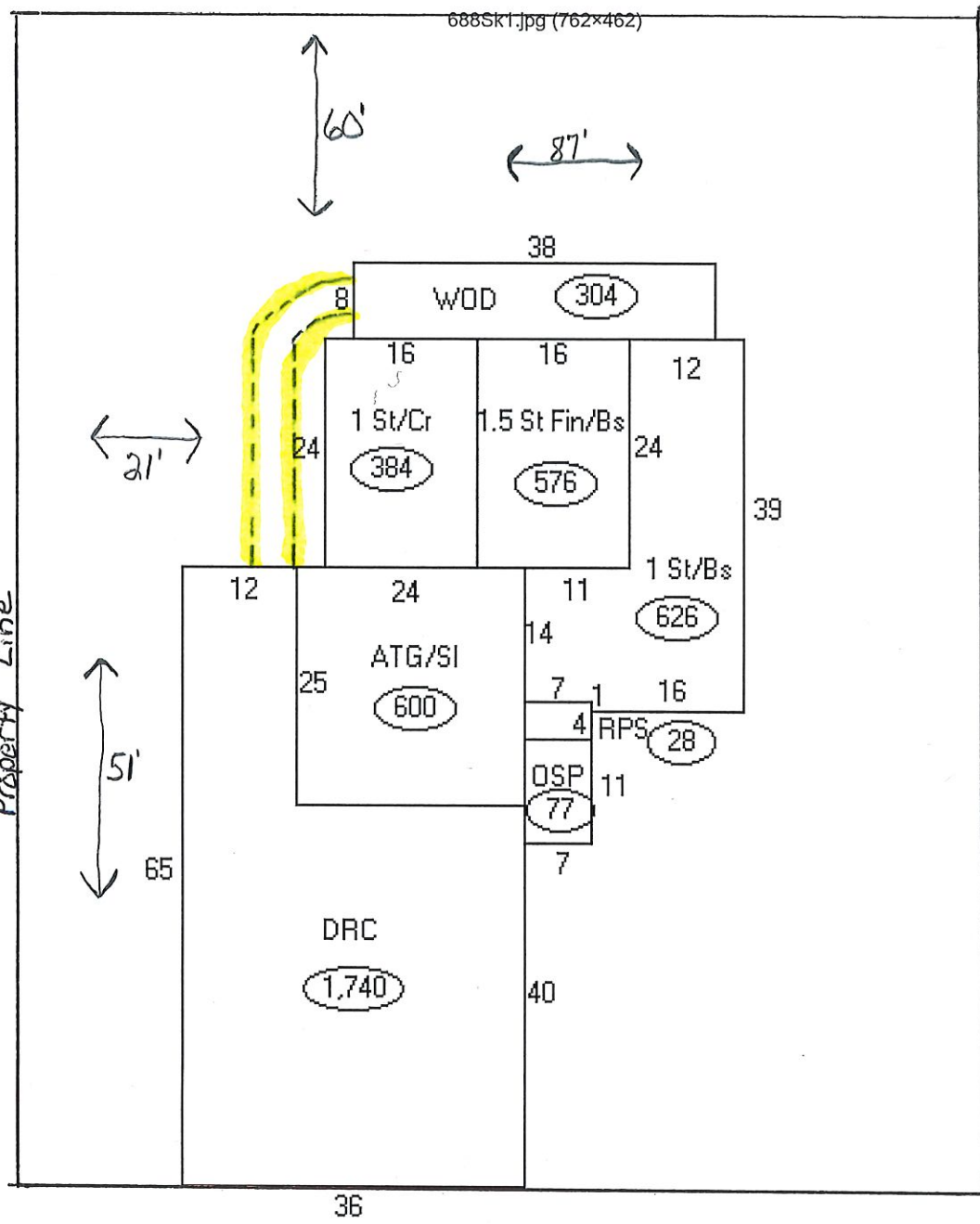

Custer Street

Zoning Classification R2

PERMIT NUMBER 2019-51
FEE \$10.00 CASH _____ CHECK# 7203

APPLICATION FOR A DEMOLITION PERMIT

St. Paul, Nebraska: DIRECTIONS: Fill in the following information as accurately and completely as possible. This application is not acceptable unless all required information is furnished.

Property Owner Margaret Thompson Contractor Jim Thompson

Address 1604 Paul st Address 726 12th Ave ST Paul

City, State, Zip ST Paul Ne 68873 Phone Number _____

Phone Number 308 754-4584 Cell Phone 308 571-0454

Complete Legal Description of the Property (SP TWP) tract in SW 1/4 SW 1/4 33-15-10

Address of Demolition Site 1604 Paul st ST Paul (8 acres)

Structure to be demolished barn

Approximately when will demolition Start 9-1-19 Finish 12-15-19

Asbestos Inspection Conducted? Yes _____ No X **Attach inspection report.**

To Whom Should the Improvements be assessed? Margaret Thompson

Contact Utility Superintendent at (308) 754-4483 regarding Inspection. Date of visit Matt Helzer 8-9-19
(Matt Helzer's signature)

Recommendations needed before approval: _____

MUST CALL DIGGERS HOTLINE @ 811 BEFORE DIGGING – CONSTRUCTION ON UTILITY EASEMENTS IS NOT PERMITTED. The above information is, to the best of my knowledge, true and accurate. It is understood and agreed that any error, misstatement or misrepresentation of fact, either with or without intention on my part, such as might, if known, cause a refusal of this application, or any alteration or change in plans made without the approval of the Zoning Administrator subsequent to the issuance of the Permit, shall constitute sufficient grounds for the revocation of such permit. This permit is valid for one (1) year from approval date.

The signature also indicates permission granted to the Zoning Administrator to inspect the demolition site in which this permit is granted at any time until completed.

Signature of Applicant Margaret Thompson Date 8-9-19

Taxes must be paid in full prior to demolishing/removing any structure. Treasurer's certificate of approval to move or demolish the building MUST be attached.

For Office Use Only:

Permit is Approved _____ Denied _____ Date _____
Zoning Administrator

Reasons for Denial: _____



2019-51

TAX RECEIPT

JACKIE SYNOWSKI HOWARD COUNTY TREASURER

Parcel # 470307230 Roll Year 2018 Receipt No. 2018-0002100
Legal (SP TWP) TRACT IN SW1/4 SW1/4 Date of Payment: 04/18/2019
33-15-10 (8 ACRES) Type of Tax: REAL

1604 PAUL ST
Tax Due 12/31/2018 TAX DISTRICT 2 Original Tax 498.84
Delinquent TAX RATE 1.252572 Tax Before Credit 923.30
1st Half 05/01/2019 VALUE 79,179 Homstead Credit 424.46
2nd Half 09/04/2019 Late Filing Fee: 0.00

MTHOMPSON CHECK
PAID BY: MARGARET THOMPSON
The tax loss is reimbursed by the state as a homestead exemption.
Receipt voided until final payment of any check or draft tendered.

THOMPSON/MARGARET
1604 PAUL ST
ST PAUL NE 68873-3613
Payment 1st HALF
Installment 249.42
Interest 0.00
Advertising 0.00
Penalty 0.00

TOTAL COLLECTED 249.42

COMMENTS

RECEIPT

TAX RECEIPT

JACKIE SYNOWSKI HOWARD COUNTY TREASURER

Parcel # 470307230 Roll Year 2018 Receipt No. 2018-0005844
Legal (SP TWP) TRACT IN SW1/4 SW1/4 Date of Payment: 08/09/2019
33-15-10 (8 ACRES) Type of Tax: REAL

1604 PAUL ST
Tax Due 12/31/2018 TAX DISTRICT 2 Original Tax 498.84
Delinquent TAX RATE 1.252572 Tax Before Credit 923.30
1st Half 05/01/2019 VALUE 79,179 Homstead Credit 424.46
2nd Half 09/04/2019 Late Filing Fee: 0.00

MTHOMPSON CHECK
PAID BY: MARGARET THOMPSON
The tax loss is reimbursed by the state as a homestead exemption.
Receipt voided until final payment of any check or draft tendered.

THOMPSON/MARGARET
1604 PAUL ST
ST PAUL NE 68873-3613
Payment 2nd HALF
Installment 249.42
Interest 0.00
Advertising 0.00
Penalty 0.00

TOTAL COLLECTED 249.42

COMMENTS

RECEIPT

**CERTIFICATION OF TAXABLE VALUE
And VALUE ATTRIBUTABLE TO GROWTH**

(format for all political subdivisions other than
a) sanitary improvement districts in existence five years or less.
b) community colleges, and c) school districts)

TAX YEAR 2019

(certification required on or before August 20th, of each year)

TO :

TAXABLE VALUE LOCATED IN THE COUNTY OF HOWARD COUNTY

Name of Political Subdivision	Subdivision Type (e.g. city, fire, NRD)	Value attributable to Growth	Total Taxable Value
ST PAUL CITY	CITY/VILLAGE	1,135,127	127,104,101

**Value attributable to growth is determined pursuant to section 13-518 which includes real and personal property and annexation, if applicable.*

I Neal Dethlefs, Howard County Assessor hereby certify that the valuation listed herein is, to the best of my knowledge and belief, the true and accurate taxable valuation for the current year, pursuant to Neb. Rev. Stat. 13-509 and 13-518.

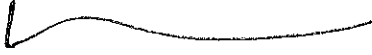

(signature of county assessor)

8-13-19
(date)

CC: County Clerk, Howard County
CC: County Clerk where district is headquartered, if different county, Howard County

Note to political subdivision: A copy of the Certification of Value must be attached to your budget document.

Guideline form provided by Nebraska Depr. of Revenue Property Assessment Division, Rev. 2019

CERTIFICATION OF VALUE
FOR COMMUNITY REDEVELOPMENT PROJECTS
Or Tax Increment Financing Projects (TIF)
BASE AND EXCESS VALUE

TAX YEAR 2019

(certification required annually)

TO City or Community Redevelopment authority (CRA):

TIF BASE & EXCESS VALUE LOCATED IN THE CITY OF ST PAUL

LOCATED IN THE COUNTY OF HOWARD

Name of TIF Project	TIF Base Value	TIF Excess Value
PRAIRE FALLS 8652	16,390	157,524

I Neal Dethlefs, Howard County Assessor hereby certify that the valuation listed herein is, to the best of my knowledge and belief, the true and accurate BASE and EXCESS valuations for the Community Redevelopment/Tax Increment Financing Projects (TIF) for the current year, pursuant to Neb. Rev. Stat. 18-2148, 18-2149 and 13-509.

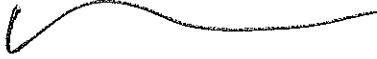

(signature of county assessor)

8-13-19

(date)

CC: County Clerk, Howard County
CC: County Treasurer, Howard County

CERTIFICATION OF VALUE
FOR COMMUNITY REDEVELOPMENT PROJECTS
Or Tax Increment Financing Projects (TIF)
BASE AND EXCESS VALUE

TAX YEAR 2019
(certification required annually)

TO City or Community Redevelopment authority (CRA):

TIF BASE & EXCESS VALUE LOCATED IN THE CITY OF ST PAUL

LOCATED IN THE COUNTY OF HOWARD

Name of TIF Project	TIF Base Value	TIF Excess Value
DALTON MEADOWS 8653	11,657	282,254

I Neal Dethlefs, Howard County Assessor hereby certify that the valuation listed herein is, to the best of my knowledge and belief, the true and accurate BASE and EXCESS valuations for the Community Redevelopment/Tax Increment Financing Projects (TIF) for the current year, pursuant to Neb. Rev. Stat. 18-2148, 18-2149 and 13-509.



(signature of county assessor)

8-13-19
(date)

CC: County Clerk, Howard County
CC: County Treasurer, Howard County

CERTIFICATION OF VALUE
FOR COMMUNITY REDEVELOPMENT PROJECTS
Or Tax Increment Financing Projects (TIF)
BASE AND EXCESS VALUE

TAX YEAR 2019
(certification required annually)

TO City or Community Redevelopment authority (CRA):

TIF BASE & EXCESS VALUE LOCATED IN THE CITY OF ST PAUL
LOCATED IN THE COUNTY OF HOWARD

Name of TIF Project	TIF Base Value	TIF Excess Value
DALTON MEADOWS 8654	12,001	250,372

I Neal Dethlefs, Howard County Assessor hereby certify that the valuation listed herein is, to the best of my knowledge and belief, the true and accurate BASE and EXCESS valuations for the Community Redevelopment/Tax Increment Financing Projects (TIF) for the current year, pursuant to Neb. Rev. Stat. 18-2148, 18-2149 and 13-509.

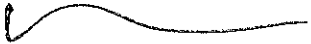

(signature of county assessor)

8-13-19
(date)

CC: County Clerk, Howard County
CC: County Treasurer, Howard County

CERTIFICATION OF VALUE
FOR COMMUNITY REDEVELOPMENT PROJECTS
Or Tax Increment Financing Projects (TIF)
BASE AND EXCESS VALUE

TAX YEAR 2019
(certification required annually)

TO City or Community Redevelopment authority (CRA):

TIF BASE & EXCESS VALUE LOCATED IN THE CITY OF ST PAUL

LOCATED IN THE COUNTY OF HOWARD

Name of TIF Project	TIF Base Value	TIF Excess Value
DALTON MEADOWS 8655	29,997	276,165

I Neal Dethlefs, Howard County Assessor hereby certify that the valuation listed herein is, to the best of my knowledge and belief, the true and accurate BASE and EXCESS valuations for the Community Redevelopment/Tax Increment Financing Projects (TIF) for the current year, pursuant to Neb. Rev. Stat. 18-2148, 18-2149 and 13-509.



(signature of county assessor)

8-13-19
(date)

CC: County Clerk, Howard County
CC: County Treasurer, Howard County

CERTIFICATION OF VALUE
FOR COMMUNITY REDEVELOPMENT PROJECTS
Or Tax Increment Financing Projects (TIF)
BASE AND EXCESS VALUE

TAX YEAR 2019
(certification required annually)

TO City or Community Redevelopment authority (CRA):

TIF BASE & EXCESS VALUE LOCATED IN THE CITY OF ST PAUL

LOCATED IN THE COUNTY OF HOWARD

Name of TIF Project	TIF Base Value	TIF Excess Value
DALTON MEADOWS 8656	29,988	225,819

I Neal Dethlefs, Howard County Assessor hereby certify that the valuation listed herein is, to the best of my knowledge and belief, the true and accurate BASE and EXCESS valuations for the Community Redevelopment/Tax Increment Financing Projects (TIF) for the current year, pursuant to Neb. Rev. Stat. 18-2148, 18-2149 and 13-509.

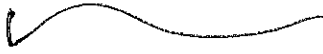

(signature of county assessor)

8-13-19
(date)

CC: County Clerk, Howard County
CC: County Treasurer, Howard County

CERTIFICATION OF VALUE
FOR COMMUNITY REDEVELOPMENT PROJECTS
Or Tax Increment Financing Projects (TIF)
BASE AND EXCESS VALUE

TAX YEAR 2019

(certification required annually)

TO City or Community Redevelopment authority (CRA):

TIF BASE & EXCESS VALUE LOCATED IN THE CITY OF ST PAUL

LOCATED IN THE COUNTY OF HOWARD

Name of TIF Project	TIF Base Value	TIF Excess Value
PRAIRE FALLS 8657	7,260	76,784

I Neal Dethlefs, Howard County Assessor hereby certify that the valuation listed herein is, to the best of my knowledge and belief, the true and accurate BASE and EXCESS valuations for the Community Redevelopment/Tax Increment Financing Projects (TIF) for the current year, pursuant to Neb. Rev. Stat. 18-2148, 18-2149 and 13-509.



(signature of county assessor)

8-13-19

(date)

CC: County Clerk, Howard County
CC: County Treasurer, Howard County

CERTIFICATION OF VALUE
FOR COMMUNITY REDEVELOPMENT PROJECTS
Or Tax Increment Financing Projects (TIF)
BASE AND EXCESS VALUE

TAX YEAR 2019

(certification required annually)

TO City or Community Redevelopment authority (CRA):

TIF BASE & EXCESS VALUE LOCATED IN THE CITY OF ST PAUL

LOCATED IN THE COUNTY OF HOWARD

Name of TIF Project	TIF Base Value	TIF Excess Value
DALTON MEADOWS 8658	13,250	298,719

I Neal Dethlefs, Howard County Assessor hereby certify that the valuation listed herein is, to the best of my knowledge and belief, the true and accurate BASE and EXCESS valuations for the Community Redevelopment/Tax Increment Financing Projects (TIF) for the current year, pursuant to Neb. Rev. Stat. 18-2148, 18-2149 and 13-509.

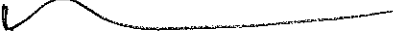

(signature of county assessor)

8-13-19
(date)

CC: County Clerk, Howard County
CC: County Treasurer, Howard County

CERTIFICATION OF VALUE
FOR COMMUNITY REDEVELOPMENT PROJECTS
Or Tax Increment Financing Projects (TIF)
BASE AND EXCESS VALUE

TAX YEAR 2019
(certification required annually)

TO City or Community Redevelopment authority (CRA):

TIF BASE & EXCESS VALUE LOCATED IN THE CITY OF ST PAUL

LOCATED IN THE COUNTY OF HOWARD

Name of TIF Project	TIF Base Value	TIF Excess Value
PRAIRE FALLS 8659	7,260	202,728

I Neal Dethlefs, Howard County Assessor hereby certify that the valuation listed herein is, to the best of my knowledge and belief, the true and accurate BASE and EXCESS valuations for the Community Redevelopment/Tax Increment Financing Projects (TIF) for the current year, pursuant to Neb. Rev. Stat. 18-2148, 18-2149 and 13-509.



(signature of county assessor)

8-13-19

(date)

CC: County Clerk, Howard County
CC: County Treasurer, Howard County

CERTIFICATION OF VALUE
FOR COMMUNITY REDEVELOPMENT PROJECTS
Or Tax Increment Financing Projects (TIF)
BASE AND EXCESS VALUE

TAX YEAR 2019

(certification required annually)

TO City or Community Redevelopment authority (CRA):

TIF BASE & EXCESS VALUE LOCATED IN THE CITY OF ST PAUL

LOCATED IN THE COUNTY OF HOWARD

Name of TIF Project	TIF Base Value	TIF Excess Value
DALTON MEADOWS 8660	10,567	94,206

I Neal Dethlefs, Howard County Assessor hereby certify that the valuation listed herein is, to the best of my knowledge and belief, the true and accurate BASE and EXCESS valuations for the Community Redevelopment/Tax Increment Financing Projects (TIF) for the current year, pursuant to Neb. Rev. Stat. 18-2148, 18-2149 and 13-509.



(signature of county assessor)

8-13-19

(date)

CC: County Clerk, Howard County
CC: County Treasurer, Howard County

1	LIGHT #1	17-18 Actual	18-19 Budget	18-19 Estimate	19-20 Budget
2	REVENUE				
3	Rental: St NE, Pole Rent	\$ 3,215.00	\$ 4,950.00	\$ 4,950.00	\$ 4,950.00
4	Reconnect Fee 01-255	\$ 835.00	\$ 500.00	\$ 300.00	\$ 300.00
5	Disconnect Notice Fee 01-256	\$ 15,226.00	\$ 13,500.00	\$ 13,500.00	\$ 13,500.00
6	Bad Check Fee \$25	\$ 275.00	\$ -	\$ 100.00	\$ -
7	Interest (504981 + 6 CD's)	\$ 9,055.00	\$ 7,000.00	\$ 8,500.00	\$ 7,000.00
8	Metered Sales 1%	\$ 2,623,263.00	\$ 2,629,407.00	\$ 2,629,407.00	\$ 2,655,701.00
9	Metered Cons. Dep. CC 01-491	\$ 3,200.00	\$ 1,500.00	\$ 2,494.00	\$ 1,500.00
10	Reimburse: LARM	\$ 5,922.00	\$ -	\$ 5,879.00	\$ -
11	Sale Tx Form 10: 1%	\$ 174,556.00	\$ 181,911.00	\$ 181,911.00	\$ 183,730.00
12	No City Sales Tax: 1%	\$ 1,189.00	\$ 1,190.00	\$ 1,190.00	\$ 1,202.00
13	Grant (NPPD): Elect. car area \$-0-	\$ -	\$ -	\$ -	\$ -
14	TOTAL REVENUES	\$ 2,836,736.00	\$ 2,839,958.00	\$ 2,848,231.00	\$ 2,867,883.00
15					
16	EXPENSE				
17	PERSONNEL SERVICES				
18	Salary & Wages 3%	\$ 213,994.00	\$ 213,008.00	\$ 234,393.00	\$ 241,379.00
19	Overtime	\$ 9,402.00	\$ 5,000.00	\$ 8,588.00	\$ 5,000.00
20	Fica - 6.20%	\$ 13,000.00	\$ 13,207.00	\$ 15,064.00	\$ 15,276.00
21	Medicare - 1.45%	\$ 3,040.00	\$ 3,089.00	\$ 3,523.00	\$ 3,573.00
22	Pension 6%	\$ 13,246.00	\$ 12,617.00	\$ 14,579.00	\$ 14,615.00
23	Insur: Health 12% , Woodm, Life,	\$ 63,758.00	\$ 51,706.00	\$ 48,600.00	\$ 59,964.00
24	Health Ded, RCI				
25	OPERATING EXPENSE				
26	Prof & Sch (Mtr,Transf,Sub,CPR	\$ 1,487.00	\$ 2,000.00	\$ 1,409.00	\$ 2,000.00
27	Adm & Dues (Util Sec, Power	\$ 4,235.00	\$ 3,900.00	\$ 3,900.00	\$ 3,900.00
28	Pool, Sparqdata)				
29	Legal Fees (Union Negotiations)	\$ 44.00	\$ 1,000.00	\$ 700.00	\$ 1,000.00
30	Communication - Digger/St of NE	\$ 1,468.00	\$ 2,000.00	\$ 1,950.00	\$ 2,000.00
31	Gas & Oil	\$ 6,344.00	\$ 7,000.00	\$ 6,900.00	\$ 7,000.00
32	Publish & Codif. (Rate Ord.)	\$ 243.00	\$ 500.00	\$ -	\$ 500.00
33	Insurance (Liability) 10%	\$ 19,664.00	\$ 21,500.00	\$ 24,200.00	\$ 26,620.00
34	Public Utility (REA) 2%	\$ 1,953,646.00	\$ 1,934,274.00	\$ 1,781,700.00	\$ 1,799,699.00
35	Heritage UB ACH Fees \$25 Mthly	\$ 300.00	\$ 300.00	\$ 300.00	\$ 360.00
36	Uniforms - 01-20-268	\$ 920.00	\$ 950.00	\$ 946.00	\$ 950.00
37	Util R & M (Cable, Transf, pedestals)	\$ 17,341.00	\$ 40,000.00	\$ 39,500.00	\$ 40,000.00
38	Vehicle R & M (Double Bucket)	\$ 3,100.00	\$ 10,000.00	\$ 9,000.00	\$ 10,000.00
39	Tools: hand held dock/laptop	\$ 2,245.00	\$ 5,000.00	\$ 2,000.00	\$ 5,000.00
40	Sale Tx Form 10 - Line Loss	\$ 173,028.00	\$ 183,102.00	\$ 165,600.00	\$ 173,876.00
41	Check Order 411-025 Heritage	\$ -	\$ 30.00	\$ -	\$ 30.00
42	Computer - Itron 1200, Banyon Support	\$ 3,679.00	\$ 7,000.00	\$ 6,900.00	\$ 7,000.00
43	\$3200, Ebilling 890, Cyber 1600				
44	Office Supplies	\$ 1,886.00	\$ 3,000.00	\$ 2,900.00	\$ 3,000.00
45	Postage	\$ 2,026.00	\$ 2,500.00	\$ 2,470.00	\$ 2,500.00
46	Acct Fees-Audit 13160,Budget 8460	\$ 5,853.00	\$ 5,964.00	\$ 5,963.00	\$ 6,140.00
47	Util Refund - Trotter, Trueax	\$ 880.00	\$ -	\$ 1,055.00	\$ -

48	Meter Cons. Dep. CC 01-20-491	\$ 3,200.00	\$ 1,500.00	\$ 2,494.00	\$ 1,500.00
49	Bldg R&M: Copier \$1000, Quonset	\$ 5,522.00	\$ 4,000.00	\$ 3,500.00	\$ 7,000.00
50	paint \$6000				
51	<u>CAPITAL OUTLAY</u>				
52	Equip. Sink	\$ 6,000.00	\$ 6,000.00	\$ 6,000.00	\$ 6,000.00
53	Improve: Middle Loup Subdivision	\$ 8,999.00	\$ 35,000.00	\$ 34,000.00	\$ 35,000.00
54	(City absorbs Electrical) and				
55	elect. Car charge station \$0				
56	<u>DEBT SERVICE</u>				
57	Trfr Out (Gen. Util. Sup.)	\$ 15,767.00	\$ 16,838.00	\$ 16,838.00	\$ 17,217.00
58	Trfr Out (Police \$140,000)	\$ 236,810.00	\$ 140,000.00	\$ 140,000.00	\$ 140,000.00
59	Trfr Out (Park \$66,800.00)		\$ 66,800.00	\$ 66,800.00	\$ 66,800.00
60	TOTAL EXPENDITURES	\$ 2,791,127.00	\$ 2,798,785.00	\$ 2,651,772.00	\$ 2,704,899.00
61					
62	NET ANNUAL CASH FLOW	\$ 45,609.00	\$ 41,173.00	\$ 196,459.00	\$ 162,984.00
	<i>Rental - Pole Rent - Charter & Qwest</i>				
	M. Mkt #504981 = \$23,718				
	Time CD's = \$221,328				
	ICS (Citizens) = \$305,617				
	Heritage #4100744 = \$257,966				
	2018 UB Ebilling Module \$695 (one time fee) plus \$195 Annually				
	2019 Timecard Module - \$2500				
	2019 Hand held Upgrade for Lights & Water: Lap top \$400 & Reader \$1800				
	2019 Quonset moved to Northyards from TO Haas with placement of cement for flooring				
	2020 Quonset painting \$6,000				
	PAGE 1				

1	WATER #2	17-18 Actual	18-19 Budget	18-19 Estimate	19-20 Budget
2	REVENUE				
3	Fee, Permit, License (Well permit)	\$ 150.00	\$ -	\$ 30.00	\$ -
4	Rent (Exp 10/21) \$10,812 May/Oct	\$ 10,625.00	\$ 9,000.00	\$ 10,719.00	\$ 10,812.00
5	Interest (504189 + 7 CD's)	\$ 6,288.00	\$ 5,000.00	\$ 2,500.00	\$ 1,500.00
6	Special Assess	\$ 2,829.00	\$ 1,616.00	\$ 1,300.00	\$ 1,363.00
7	Assess Interest	\$ 493.00	\$ 358.00	\$ 2,146.00	\$ 228.00
8	Metered Sales (-20 million gal.)	\$ 621,544.00	\$ 665,000.00	634,950.00	\$ 634,950.00
9	Metered Deposit 102415 Activity	\$ 2,750.00	\$ -	0.00	\$ -
10	Shop Sales (Wtr Horn, Parts)	\$ 5,214.00	\$ 650.00	\$ 2,211.00	\$ 650.00
11	Antic. Bd: Ho Ave \$53,894; Mid Loup	\$ -	\$ 117,958.00	\$ -	\$ 273,145.00
12	\$219,251				
13	Reimb: Infill Fritz Lee \$10,982, Larm,	\$ 3,079.00	\$ -	\$ 12,754.00	\$ -
14	Disaster Relief				
15	Trfr In - Sale Tax - Mid Loup Subd	\$ -	\$ -	\$ -	\$ -
16	Bond Pymt \$219,251				
17	TOTAL REVENUES	\$ 652,972.00	\$ 799,582.00	\$ 666,610.00	\$ 922,648.00
18	EXPENSE				
19	PERSONNEL SERVICES				
20	Wages: Switzer, Gorecki, Wrob 50%,	\$ 123,549.00	\$ 126,205.00	\$ 120,000.00	\$ 151,299.00
21	Berth 50%, new Sec 25%				
22	Overtime - Water Testing, on call	\$ 5,059.00	\$ 5,000.00	\$ 6,544.00	\$ 5,000.00
23	Fica - 6.20%	\$ 7,342.00	\$ 8,135.00	\$ 7,845.00	\$ 9,691.00
24	Medicare - 1.45%	\$ 1,717.00	\$ 1,903.00	\$ 1,835.00	\$ 2,266.00
25	Pension 6%	\$ 7,716.00	\$ 7,872.00	\$ 7,593.00	\$ 9,378.00
26	Insur: Health 12%, Woodm, Life &	\$ 46,524.00	\$ 36,082.00	\$ 32,859.00	\$ 42,624.00
27	Health Ded., RCI				
28	OPERATING EXPENSE				
29	Prof. & Schools (All Licenses + Grade 3	\$ 865.00	\$ 2,200.00	\$ 1,000.00	\$ 2,500.00
30	Adm & Dues (Util Sect, RW,Sparq,	\$ 3,779.00	\$ 3,600.00	\$ 3,000.00	\$ 3,100.00
31	BOK fees)				
32	Legal Fees (Union & rate increase)	\$ 123.00	\$ 500.00	\$ 500.00	\$ 500.00
33	Eng. Fees: Inspect. (Antic. Bd)	\$ -	\$ 2,000.00	\$ 4,103.00	\$ 6,055.00
34	Ho Ave \$6,055				
35	Wire Fee (Bond Pymts) 8x4	\$ 48.00	\$ 40.00	\$ 40.00	\$ 40.00
36	Communication - St of Ne, One Call	\$ 1,717.00	\$ 2,000.00	\$ 2,000.00	\$ 2,500.00
37	Gas & Oil: Wellfield \$1000 & truck	\$ 3,183.00	\$ 2,800.00	\$ 3,500.00	\$ 4,500.00
38	Lab Sample	\$ 1,967.00	\$ 2,000.00	\$ 1,700.00	\$ 1,700.00
39	Publish: CCR, Backflow, Frozen Pipes	\$ 820.00	\$ 600.00	\$ 700.00	\$ 700.00
40	Insurance Liability 10% Flood	\$ 21,675.00	\$ 23,000.00	\$ 24,408.00	\$ 26,849.00
41	Public Utility (REA) 2%	\$ 16,120.00	\$ 18,800.00	\$ 16,000.00	\$ 17,500.00
42	City Lights	\$ 25,063.00	\$ 25,000.00	\$ 23,426.00	\$ 25,000.00
43	Blackhills Gas	\$ 2,565.00	\$ 2,500.00	\$ 2,500.00	\$ 2,600.00
44	Uniforms	\$ 615.00	\$ 650.00	\$ 614.00	\$ 650.00
45	Water Meter Purch.	\$ 9,985.00	\$ 17,000.00	\$ 21,784.00	\$ 25,000.00
46	Utility R & M -Brass, valve, Filter 2	\$ 17,174.00	\$ 27,650.00	\$ 25,000.00	\$ 25,000.00

47	Veh. R & M- Bk Hoe, TO Haas	\$ 2,535.00	\$ 2,000.00	\$ 3,000.00	\$ 2,000.00
48	(Helzer Truck to other Depts)				
49	Tools: Meter Reader	\$ 760.00	\$ 1,500.00	\$ 2,800.00	\$ 1,500.00
50	Chemicals: (Chlor, Potassium, Mag)	\$ 4,294.00	\$ 6,000.00	\$ 5,000.00	\$ 5,000.00
51	Computer: office \$3000, Cyber \$2000	\$ 3,273.00	\$ 18,200.00	\$ 7,000.00	\$ 7,000.00
52	Office Supplies	\$ 1,531.00	\$ 2,000.00	\$ 1,500.00	\$ 2,000.00
53	Postage- lab, Box Permit, Postage 160	\$ 2,332.00	\$ 2,200.00	\$ 2,000.00	\$ 2,200.00
54	Acct Fees-Audit 13160,Budget 8460	\$ 5,853.00	\$ 5,964.00	\$ 5,963.00	\$ 6,140.00
55	Build R & M (Copier, Pest)	\$ 3,876.00	\$ 3,000.00	\$ 2,500.00	\$ 3,000.00
56	CAPITAL OUTLAY				
57	Improve: Scada \$17500;fire file \$1200;	\$ 18,398.00	\$ 156,211.00	\$ 16,222.00	\$ 287,060.00
58	shelving \$1000, Ho. Ave. \$47,839				
59	Mid Loup 219,251 or Water Tank				
60	Equipment Sinking (US Partial Truck)	\$ 5,000.00	\$ 25,000.00	\$ 25,000.00	\$ 25,000.00
61	Building Sinking	\$ 2,500.00	\$ 2,500.00	\$ 2,500.00	\$ 2,500.00
62	DEBT SERVICE				
63	Principal: 18-19 Wire came in Sept 2018	\$ 726,950.00	\$ 161,775.00	\$ 73,650.00	\$ 161,775.00
64	of \$87,000, NOT October 2018				
65	Interest (Bonds) same for interest	\$ 64,978.00	\$ 33,607.00	\$ 23,100.00	\$ 31,950.00
66	Trfr Out to General - Util. Sup.	\$ 15,767.00	\$ 16,838.00	\$ 16,838.00	\$ 17,217.00
67	TOTAL EXPENDITURES	\$ 1,155,653.00	\$ 752,332.00	\$ 494,024.00	\$ 918,794.00
68					
69	NET ANNUAL CASH FLOW	\$ (502,681.00)	\$ 47,250.00	\$ 172,586.00	\$ 3,854.00
	M.Mkt 504189 = \$28,999				
	Time CD's = \$117,569				
	ICS (Citizens) = \$59,278				
	Wellfield = Todd Wojtalewicz - Pymt May & October - \$10,812 Expires October 14, 2021				
	Wellfield = Clark Kosmicki - Pymt May & October - \$10,625				
	5% increase on water rate & maintenance fee - July 1, 2018				
	Water Rate Increase ???				
	Water Tower Inspection 16-17				
	Filter 1 Repaired - 2015				
***	Water Assessments - SEE ATTACHED				
	2019-2020 Howard Avenue Water - \$54,000				
	PAGE 2				

1	SEWER #3	17-18 Actual	18-19 Budget	18-19 Estimate	19-20 Budget
2	REVENUE				
3	Rental Lag. Exp 3/2022 \$7,000; Mar/Nov	\$ 6,400.00	\$ 6,400.00	\$ 6,700.00	\$ 7,000.00
4	Interest (504849; CD; ICS)	\$ 2,019.00	\$ 1,460.00	\$ 4,000.00	\$ 2,000.00
5	Special Assess (Kelly Court)	\$ 3,972.00	\$ 2,107.00	\$ 1,634.00	\$ 1,727.00
6	Assess Interest	\$ 608.00	\$ 482.00	\$ 2,020.00	\$ 296.00
7	Collections (3.2% increase = 6900)	\$ 316,368.00	\$ 323,900.00	\$ 310,000.00	\$ 310,000.00
8	Shop Sales - Rootx / Elba	\$ 270.00	\$ -	\$ 48.00	\$ -
9	Bond Antic. - Ho Ave \$106,536 &	\$ -	\$ 451,191.00	\$ -	\$ 339,424.00
10	Middle Loup Subd \$232,888				
11	25% Infrast. \$60,000 #102342	\$ -	\$ 45,000.00	\$ -	\$ 60,000.00
12	Sewer Comminutor (grinder)				
13	Reimbursement (WC)	\$ 182.00	\$ -	\$ 534.00	\$ -
14	Trfr In - Sale Tax - Mid Loup Subd	\$ -	\$ -	\$ -	\$ -
15	Sewer Bond Pymt \$232,888				
16	TOTAL REVENUES	\$ 329,819.00	\$ 830,540.00	\$ 324,936.00	\$ 720,447.00
17					
18	EXPENSE				
19	PERSONNEL SERVICES				
20	Salary & Wages = Operator/seasonal	\$ 44,329.00	\$ 59,615.00	\$ 51,742.00	\$ 52,251.00
21	Overtime	\$ 1,530.00	\$ 2,500.00	\$ 1,000.00	\$ 2,500.00
22	Fica - 6.20%	\$ 2,653.00	\$ 3,851.00	\$ 3,270.00	\$ 3,395.00
23	Medicare - 1.45%	\$ 621.00	\$ 901.00	\$ 765.00	\$ 794.00
24	Pension 6%	\$ 2,752.00	\$ 3,511.00	\$ 3,164.00	\$ 3,069.00
25	Insur: Health 12%, Woodm, Life & RCI,	\$ 17,280.00	\$ 19,531.00	\$ 18,036.00	\$ 19,884.00
26	Health Ded				
27	OPERATING EXPENSE				
28	Prof & Sch (Matt, Jeremy, Bill)	\$ 937.00	\$ 1,000.00	\$ 400.00	\$ 1,000.00
29	Adm. & Dues-Util Sect,League, BOK,Sparq	\$ 2,404.00	\$ 2,405.00	\$ 1,900.00	\$ 2,405.00
30	Legal Fees	\$ 123.00	\$ 250.00	\$ 390.00	\$ 250.00
31	Eng Fee: Mech Plant \$???; Ho Ave 12,109	\$ -	\$ 2,500.00	\$ 6,500.00	\$ 12,109.00
32	Wire Bank Fees - \$8 each	\$ 12.00	\$ 16.00	\$ 16.00	\$ 16.00
33	Communication - Diggers	\$ 108.00	\$ 300.00	\$ 150.00	\$ 300.00
34	City Gas & Oil	\$ 3,476.00	\$ 3,000.00	\$ 2,950.00	\$ 3,000.00
35	Lab Sample: Soil, influence, irrigation	\$ 3,273.00	\$ 3,500.00	\$ 3,300.00	\$ 3,500.00
36	Publish / Codif (No Flushing)	\$ 198.00	\$ 400.00	\$ 100.00	\$ 400.00
37	Insurance (Liab) 10%	\$ 4,348.00	\$ 5,300.00	\$ 5,250.00	\$ 5,775.00
38	City Lights 2%	\$ 25,715.00	\$ 32,000.00	\$ 30,000.00	\$ 32,000.00
39	Uniforms	\$ 298.00	\$ 300.00	\$ 316.00	\$ 300.00
40	Utility R & M: Maint. Lines, manhole rehab,	\$ 23,028.00	\$ 30,000.00	\$ 25,000.00	\$ 30,000.00
41	aerators				
42	Vehicle R & M (Tires)	\$ 1,442.00	\$ 1,500.00	\$ 3,151.00	\$ 2,000.00
43	Tools - battery, hammer, drill bit	\$ 43.00	\$ 300.00	\$ 321.00	\$ 300.00
44	Chemicals: Weed Spray , Rodeo	\$ 190.00	\$ 500.00	\$ 200.00	\$ 400.00
45	Computer - Cyber 1600, Support 2000	\$ 2,675.00	\$ 3,500.00	\$ 3,781.00	\$ 3,500.00
46	Office Supplies	\$ 1,065.00	\$ 1,500.00	\$ 1,200.00	\$ 1,500.00
47	Postage	\$ 1,897.00	\$ 2,200.00	\$ 1,950.00	\$ 2,200.00
48	Acct Fees-Audit 13160,Budget 8460	\$ 5,853.00	\$ 5,964.00	\$ 5,964.00	\$ 6,140.00

1	GENERAL #5	17-18 Actual	18-19 Budget	18-19 Estimate	19-20 Budget
2	REVENUE				
3	Property Tax	\$ 131,864.00	\$ 140,425.00	\$ 140,425.00	\$ 140,000.00
4	Muni-Equalization - (diff of \$19,602)	\$ 102,328.00	\$ 82,452.00	\$ 82,452.00	\$ 102,054.00
5	Franchise Tax: Charter/Blackhills	\$ 27,000.00	\$ 29,000.00	\$ 29,000.00	\$ 29,000.00
6	Zoning Permit Fees	\$ 2,560.00	\$ 1,600.00	\$ 1,600.00	\$ 1,600.00
7	Pet Tag Fees	\$ 654.00	\$ 500.00	\$ 500.00	\$ 500.00
8	Fee, Permits: Liquor & Tobacco	\$ 4,392.00	\$ 3,500.00	\$ 3,918.00	\$ 3,100.00
9	Mobile Food Fees	\$ 152.00	\$ -	\$ 442.00	\$ 400.00
10	Int. 100027,411025,504684, 8CDs	\$ 16,369.00	\$ 12,000.00	\$ 16,584.00	\$ 16,500.00
11	Trfr to Gen: Str. Tractor 20-21 Due: \$11,500 (19-20 Street Tractor \$41,500 from General)	\$ 12,000.00	\$ -	\$ -	\$ 30,000.00
13	Trfr In: Light US Wage \$17,217	\$ 15,767.00	\$ 28,349.00	\$ 28,349.00	\$ 17,217.00
14	Trfr In: Wtr US Wage \$17,217	\$ 15,767.00	\$ 28,349.00	\$ 28,349.00	\$ 17,217.00
15	Trfr In: Swr US Wage \$17,217	\$ 15,767.00	\$ 28,349.00	\$ 28,349.00	\$ 17,217.00
16	Trfr In: Street US Wage 17,217	\$ 15,767.00	\$ 28,349.00	\$ 28,349.00	\$ 17,217.00
17	Reimb: SCEDD dues; Killinger UHC; Jury Duty	\$ 6,621.00	\$ -	\$ 1,969.00	\$ -
18	Grant: Downtown Revitalization \$400,000	\$ -	\$ -	\$ -	\$ 400,000.00
19	Reserve: Heritage 411025	\$ -	\$ -	\$ -	\$ 100,000.00
20	Reserve: Office Renovation,Flooring,Phone	\$ -	\$ -	\$ -	\$ 38,700.00
21	is \$38,700 From #411025 \$38,700				
22	TOTAL REVENUES	\$ 367,008.00	\$ 382,873.00	\$ 390,286.00	\$ 930,722.00
23	EXPENSE				
24	PERSONNEL SERVICES				
25	Wage: Clerk, US, Royle, Council; Plan Sec	\$ 179,824.00	\$ 218,827.00	\$ 191,000.00	\$ 209,598.00
26	Overtime - Plan Secretary	\$ 868.00	\$ 700.00	\$ 2,100.00	\$ 2,000.00
27	Fica - 6.20%	\$ 10,246.00	\$ 13,611.00	\$ 11,972.20	\$ 13,119.00
28	Medicare - 1.45%	\$ 2,396.00	\$ 3,183.00	\$ 2,800.00	\$ 3,068.00
29	Pension 6%	\$ 10,109.00	\$ 12,439.00	\$ 11,586.00	\$ 11,130.00
30	Insur: Health 12%, Woodm, Life, RCI,	\$ 56,429.00	\$ 68,353.00	\$ 51,891.00	\$ 67,284.00
31	Health Ded				
32	OPERATING EXPENSE				
33	125 Plan: All Dept Tasc annual fee	\$ 1,663.00	\$ 1,700.00	\$ 1,856.00	\$ 1,900.00
34	Payroll ACH Fees: ALL DEPTS	\$ 382.00	\$ 400.00	\$ 350.00	\$ 400.00
35	Prof & Schools: meals & mileage	\$ 4,396.00	\$ 5,500.00	\$ 5,274.00	\$ 5,500.00
36	Memb & Dues: Pet Lic Fee, Loup Basin, Sparq	\$ 3,852.00	\$ 1,612.00	\$ 1,612.00	\$ 1,612.00
37	Legal Fees - Union; Grievance	\$ 6,094.00	\$ 15,000.00	\$ 18,530.00	\$ 15,000.00
38	Record Fee: Ho. Co. Register of Deeds	\$ 190.00	\$ 500.00	\$ 350.00	\$ 500.00
39	Comm: St of NE - fire,pool,parks,police&emt	\$ 5,016.00	\$ 5,200.00	\$ 5,250.00	\$ 5,300.00
40	Gas & Oil	\$ 39.00	\$ 100.00	\$ -	\$ 100.00
41	Publish / Codif.	\$ 5,267.00	\$ 7,000.00	\$ 6,500.00	\$ 7,000.00
42	Insurance (Liab) 10%WC & Redlg \$1260	\$ 4,952.00	\$ 5,745.00	\$ 7,002.00	\$ 7,580.00
43	City Lights	\$ 10,201.00	\$ 10,500.00	\$ 9,500.00	\$ 10,500.00
44	Uniforms: Matt, Office Staff	\$ 1,281.00	\$ 1,000.00	\$ 1,342.00	\$ 1,665.00
45	Public Maint: - Hilmer / Vacant Lots	\$ 650.00	\$ 2,000.00	\$ -	\$ 2,000.00
46	Donation: Crisis 1200, Chamb. \$5000,	\$ 9,200.00	\$ 9,200.00	\$ 8,200.00	\$ 7,200.00

1	BUILDING SINKING (11 Code)	17-18 Actual	18-19 Budget	18-19 Estimate	19-20 Budget
2	<u>REVENUE</u>				
3	Interest CD#108798	\$ 861.00	\$ 304.00	\$ 1,000.00	\$ 1,000.00
4	TOTAL REVENUES	\$ 861.00	\$ 304.00	\$ 1,000.00	\$ 1,000.00
5					
6	<u>EXPENSE</u>				
7	Improvements	\$ -	\$ -	\$ -	\$ -
8	Transfer Out	\$ -	\$ -	\$ -	\$ -
9	TOTAL EXPENDITURES	\$ -	\$ -	\$ -	\$ -
10	NET ANNUAL CASH FLOW	\$ 861.00	\$ 304.00	\$ 1,000.00	\$ 1,000.00
	*** ICS (Citizens) \$47,041 (Building)				
	PAGE 6				

1	STREET #7	17-18 Actual	18-19 Budget	18-19 Estimate	19-20 Budget
2	REVENUE				
3	Street Property Tax	\$ -	\$ -	\$ -	\$ -
4	Motor Veh Tax (from Sales Tax)	\$ 42,293.00	\$ 40,000.00	\$ 40,000.00	\$ 40,000.00
5	Prorate-Motor Veh. Tax	\$ 1,618.00	\$ 1,000.00	\$ 1,000.00	\$ 1,000.00
6	Motor Tax Coll. - from Co. Treas.	\$ 43,554.00	\$ 42,000.00	\$ 42,000.00	\$ 42,000.00
7	Highway Alloc (St. Dept. Roads)	\$ 279,593.00	\$ 296,916.00	\$ 296,916.00	\$ 318,245.00
8	Street Build NE	\$ 11,545.00	\$ 15,000.00	\$ 15,000.00	\$ -
9	Incentive Pymts	\$ 3,000.00	\$ 3,000.00	\$ 3,000.00	\$ 4,000.00
10	Motor Tax Fee (Hwy Alloc.)	\$ 23,325.00	\$ 20,000.00	\$ 20,000.00	\$ 20,000.00
11	Recording Fee	\$ 10.00	\$ -	\$ 10.00	\$ -
12	Flag Proceeds	\$ 132.00	\$ -	\$ -	\$ -
13	Curb Grind	\$ 2,128.00	\$ 1,000.00	\$ 3,149.00	\$ 1,000.00
14	Int. (504915, 505014)	\$ 95.00	\$ -	\$ 135.00	\$ -
15	Assess Princ. - Casey, O,L,N,	\$ 235,176.00	\$ 13,668.00	\$ 34,470.00	\$ 12,498.00
16	3rd, Jay, Custer				
17	Assess Interest	\$ 948.00	\$ 7,754.00	\$ 7,538.00	\$ 5,593.00
18	Shop Sales	\$ 875.00	\$ -	\$ -	\$ -
19	Bond Antic. - Ho Ave \$717,675;	\$ -	\$ 2,649,005.00	\$ -	\$ 2,067,322.00
20	(total project \$878,102)				
21	Middle Loup Sub \$1,349,647;				
22	"M" between Sheridan & Sherman \$115,835;				
23	Kendall between Jackson & Wallace \$71,563;				
24	Paul St. "N" of Matelyn: Paving \$47,126; Eng \$8,334				
25	Archer Credit: Kendall E of 2nd to alley (Paving \$65,000; Storm Sewer \$35,000; Engin \$19,651)				
26	Reimb. - NW Drain & WC	\$ 243.00	\$ -	\$ 6,959.00	\$ -
27	Trfr In - Sales Tax - Mid Loup Sub	\$ -	\$ -	\$ -	
28	Bond Pymt \$1,229,180				
29	TOTAL REVENUES	\$ 644,535.00	\$ 3,089,343.00	\$ 470,177.00	\$ 2,511,658.00
30	EXPENSE				
31	PERSONNEL SERVICES				
32	Salary & Wages	\$ 96,074.00	\$ 101,317.00	\$ 98,000.00	\$ 95,930.00
33	Overtime	\$ 6,954.00	\$ 10,500.00	\$ 6,500.00	\$ 10,500.00
34	Fica - 6.20%	\$ 5,790.00	\$ 6,932.00	\$ 6,479.00	\$ 6,599.00
35	Medicare - 1.45%	\$ 1,354.00	\$ 1,621.00	\$ 1,515.00	\$ 1,543.00
36	Pension 6%	\$ 6,182.00	\$ 6,709.00	\$ 6,270.00	\$ 6,386.00
37	Insur: Health 12%, Woodmen,	\$ 38,035.00	\$ 38,641.00	\$ 35,253.00	\$ 45,480.00
38	Life, RCI & Health Ded				
39	OPERATING EXPENSE				
40	Prof. & Sch -Spray Cert.	\$ 226.00	\$ 750.00	\$ 600.00	\$ 750.00
41	Adm. & Dues (League & Utility	\$ 2,174.00	\$ 2,400.00	\$ 2,300.00	\$ 2,400.00
42	Sect., Sparq, BOK fees)				
43	Eng Fee: 1& 6 \$2000 and	\$ 36,453.00	\$ 130,000.00	\$ 50,634.00	\$ 86,742.00
44	NBCS 2,000, 2019 Pav \$82,742		\$ -		
45	Gas & Oil - Snow Removal	\$ 11,864.00	\$ 11,000.00	\$ 12,700.00	\$ 13,000.00
46	Insurance (Liab & Tractor) 10%	\$ 15,137.00	\$ 16,000.00	\$ 16,214.00	\$ 17,835.00
47	City Lights	\$ 33,951.00	\$ 39,000.00	\$ 35,475.00	\$ 39,000.00
48	Blackhills Gas	\$ 2,973.00	\$ 3,500.00	\$ 2,800.00	\$ 3,500.00
49	Uniforms	\$ 592.00	\$ 600.00	\$ 641.00	\$ 600.00

1	FIRE #8	17-18 Actual	18-19 Budget	18-19 Estimate	19-20 Budget
2	REVENUE				
3	Property Tax	\$ 29,157.00	\$ 29,000.00	\$ 29,000.00	\$ 29,000.00
4	Refunds	\$ 21,749.00	\$ 20,000.00	\$ 20,000.00	\$ 20,000.00
5	Invest. Interest	\$ 1,865.00	\$ 1,400.00	\$ 1,870.00	\$ 1,500.00
6	Collections	\$ -	\$ 500.00	\$ -	\$ 500.00
7	Reimb (Fire Boots)	\$ 7,244.00	\$ -	\$ 1,622.00	\$ -
8	TOTAL REVENUES	\$ 60,015.00	\$ 50,900.00	\$ 52,492.00	\$ 51,000.00
9					
10	PERSONNEL SERVICES				
11	Insurance (United Life)	\$ 3,821.00	\$ 4,000.00	\$ 3,357.00	\$ 4,000.00
12	OPERATING EXPENSE				
13	Prof. & Schools	\$ 1,280.00	\$ 1,500.00	\$ 900.00	\$ 1,500.00
14	Gas & Oil - Grass Fires	\$ 2,013.00	\$ 2,000.00	\$ 900.00	\$ 2,000.00
15	Insurance (Liability) 10%	\$ 8,472.00	\$ 8,550.00	\$ 8,522.00	\$ 9,374.00
16	City Lights	\$ 1,677.00	\$ 1,700.00	\$ 1,511.00	\$ 1,700.00
17	Blackhills Gas	\$ 4,063.00	\$ 4,000.00	\$ 4,060.00	\$ 4,100.00
18	Utility R & M	\$ 843.00	\$ 1,200.00	\$ 1,239.00	\$ 1,200.00
19	Vehicle R & M	\$ 5,314.00	\$ 7,000.00	\$ 2,457.00	\$ 7,000.00
20	Tools	\$ 63.00	\$ 1,500.00	\$ 100.00	\$ 1,000.00
21	Fire Extrication Billing (10%)	\$ -	\$ 50.00	\$ -	\$ 50.00
22	Rural Fire Reimb. (1/2 Runs)	\$ -	\$ 250.00	\$ -	\$ 250.00
23	Bldg R&M - garb, door to	\$ 1,217.00	\$ 4,000.00	\$ 1,713.00	\$ 3,500.00
24	"N" meet room, HVAC				
25	CAPITAL OUTLAY				
26	Mach&Eq:radio, coat, boots &	\$ 21,480.00	\$ 7,000.00	\$ 9,933.00	\$ 7,000.00
27	helmets,gloves, door opener				
28	Equipment Sinking	\$ 3,000.00	\$ 3,000.00	\$ 3,000.00	\$ 3,000.00
29	Building Sinking	\$ 5,000.00	\$ 5,000.00	\$ 5,000.00	\$ 5,000.00
30	DEBT SERVICE				
31	Principal (Loan) Paid in Full	\$ -	\$ -	\$ -	\$ -
32	Interest (Loan) Paid in Full	\$ -	\$ -	\$ -	\$ -
33	TOTAL EXPENDITURES	\$ 58,243.00	\$ 50,750.00	\$ 42,692.00	\$ 50,674.00
34	NET ANNUAL CASH FLOW	\$ 1,772.00	\$ 150.00	\$ 9,800.00	\$ 326.00
	M.Mkt #504992 = \$19,429	16-17 Wash Machine \$6,000 for Contamination			
	Time CD's = \$77,552	16-17 Door \$2,000			
	ICS = \$53,201	2018 Bunker Gear Racks			
	PAGE 8				

1	POLICE #9	17-18 Actual	18-19 Budget	18-19 Estimate	19-20 Budget
2	REVENUE				
3	Property Tax	\$ 235,660.00	\$ 238,000.00	\$ 238,000.00	\$ 238,000.00
4	Accident Report Fee	\$ 40.00	\$ 40.00	\$ 30.00	\$ 40.00
5	Gun Permit; Golf/UTV License	\$ 85.00	\$ 70.00	\$ 445.00	\$ 535.00
6	Bike Auction	\$ 10.00	\$ 36.00	\$ -	\$ -
7	Interest 504860	\$ 133.00	\$ 60.00	\$ 400.00	\$ 200.00
8	Veh Sale: SUV Trade \$3500	\$ -	\$ 2,500.00	\$ 3,800.00	\$ 3,500.00
9	& Koperski Abandon Veh. 2016 - Hold 5 years				
10	Transfer In	\$ 140,000.00	\$ 140,000.00	\$ 140,000.00	\$ 140,000.00
11	Reimburse: Larm & Soto	\$ 1,395.00	\$ -	\$ 1,701.00	\$ -
12	Reserve Acct: 504860 \$17700 - SUV	\$ -	\$ -	\$ 17,500.00	\$ 17,700.00
13	TOTAL REVENUES	\$ 377,323.00	\$ 380,706.00	\$ 401,876.00	\$ 399,975.00
14	PERSONNEL SERVICES				
15	Salary & Wages / Grant \$1500	\$ 186,448.00	\$ 196,872.00	\$ 197,807.00	\$ 205,088.00
16	OT - EPC, robbery, domestic,	\$ 5,454.00	\$ 3,500.00	\$ 3,000.00	\$ 3,500.00
17	accidents & Costello school				
18	Fica 6.20%	\$ 11,221.00	\$ 12,423.00	\$ 12,450.00	\$ 12,932.00
19	Medicare 1.45%	\$ 2,624.00	\$ 2,905.00	\$ 2,912.00	\$ 3,024.00
20	Pension 6%	\$ 11,514.00	\$ 12,022.00	\$ 12,048.00	\$ 12,515.00
21	Insur: Health 12%, Woodm, Life	\$ 63,920.00	\$ 39,743.00	\$ 46,823.00	\$ 54,468.00
22	RCI & Health Ded				
23	OPERATING EXPENSE				
24	Prof & Sch-CE hrs,homicide 1620	\$ 6,666.00	\$ 4,000.00	\$ 2,000.00	\$ 4,000.00
25	Adm. & Dues (Assn. & POAN)	\$ 75.00	\$ 250.00	\$ 200.00	\$ 250.00
26	Legal Fees: Wroblewski	\$ -	\$ -	\$ 1,887.00	\$ -
27	Dispatcher Pay 5%	\$ 34,350.00	\$ 36,074.00	\$ 33,385.00	\$ 36,000.00
28	Animal Control	\$ 125.00	\$ 700.00	\$ 350.00	\$ 700.00
29	City Gas & Oil	\$ 6,563.00	\$ 7,500.00	\$ 8,600.00	\$ 8,600.00
30	Insurance (Liability) 10%	\$ 12,389.00	\$ 16,680.00	\$ 16,910.00	\$ 18,601.00
31	Uniforms	\$ 197.00	\$ 2,576.00	\$ 2,901.00	\$ 2,576.00
32	Veh. R & M: tires, oil, maint.	\$ 2,905.00	\$ 6,000.00	\$ 5,500.00	\$ 6,000.00
33	Tools: Cr. Book, ammo, SUV Eq,	\$ 1,894.00	\$ 10,000.00	\$ 8,000.00	\$ 10,000.00
34	Public Relations - School / fair	\$ 134.00	\$ 300.00	\$ 45.00	\$ 300.00
35	Computers: Justice \$1500;	\$ 8,870.00	\$ 5,000.00	\$ 9,997.00	\$ 3,500.00
36	COR \$1600; Intel 400				
37	CAPITAL OUTLAY				
38	Equip Purch - Used SUV	\$ 119.00	\$ 41,000.00	\$ 35,199.00	\$ 22,240.00
39	Equipment Sinking	\$ 5,000.00	\$ 1,800.00	\$ 1,800.00	\$ -
40	DEBT SERVICE				
41	TOTAL EXPENDITURES	\$ 360,468.00	\$ 399,345.00	\$ 401,814.00	\$ 404,294.00
42	NET ANNUAL CASH FLOW	\$ 16,855.00	\$ (18,639.00)	\$ 62.00	\$ (4,319.00)
***	M. Mkt #504860 = \$56,064				
***	ICS (Citizens) = \$20,193				
***	2016 Chevy Impala Police Car				

***	2019 Dodge Charger Police Car - \$24,981; Insured for \$35,000				
***	2014-2016 SUV = approx \$15,000				
	PAGE 9				

1	CEMETERY #10	17-18 Actual	18-19 Budget	18-19 Estimate	19-20 Budget
2	REVENUE				
3	Property Tax	\$ 18,818.00	\$ 19,000.00	\$ 19,000.00	\$ 19,000.00
4	Recording Fee	\$ 190.00	\$ 100.00	\$ 110.00	\$ 100.00
5	Donation (Unrestricted)	\$ 975.00	\$ 500.00	\$ 705.00	\$ 500.00
6	Lot Open / Close	\$ 10,125.00	\$ 9,000.00	\$ 9,000.00	\$ 9,000.00
7	Niche O/C: (\$200 x 3)	\$ -	\$ 150.00	\$ 150.00	\$ 600.00
8	Niche Engraving (\$150 x 3)	\$ -	\$ -	\$ 375.00	\$ 450.00
9	Int. (753122, 54131)	\$ 43.00	\$ 30.00	\$ 39.00	\$ 10.00
10	Cemetery Vases	\$ 52.00	\$ -	\$ -	\$ -
11	Elmwood Bench (3x\$500)	\$ -	\$ 1,300.00	\$ -	\$ 1,500.00
12	Perpetual Care	\$ 2,500.00	\$ 1,000.00	\$ 1,000.00	\$ 1,000.00
13	Cemetery Lot Sales	\$ 5,400.00	\$ 3,000.00	\$ 3,600.00	\$ 3,000.00
14	Columbarium Sales	\$ 1,220.00	\$ 1,600.00	\$ 2,800.00	\$ 1,600.00
15	Grant - Miller (fence, directory)	\$ -	\$ 26,500.00	\$ 25,000.00	\$ 25,000.00
16	19-20 Storage Bldg or Equip				
17	Rec'd Ho. Co. Found 7-19-19				
18	Grounds Conservation	\$ 540.00	\$ 500.00	\$ 540.00	\$ 500.00
19	(terms 2021-2022) 5 years				
20	Reimbursement - Gate	\$ 12,451.00	\$ -	\$ 423.00	\$ -
21	Reserve Acct 753-122 -	\$ -	\$ -	\$ -	\$ 3,000.00
22	(post & chains & stones)				
23	TOTAL REVENUES	\$ 52,314.00	\$ 62,680.00	\$ 62,742.00	\$ 65,260.00
24	EXPENSE				
25	PERSONNEL SERVICES				
26	Wages: Sext \$3600 & Seasonal	\$ 20,002.00	\$ 16,450.00	\$ 19,409.00	\$ 17,050.00
27	Overtime		\$ 1,100.00	\$ 400.00	\$ 1,100.00
28	Fica: 6.20%	\$ 1,279.00	\$ 1,088.00	\$ 1,228.00	\$ 1,125.00
29	Medicare : 1.45%		\$ 254.00	\$ 287.00	\$ 263.00
30	Pension 6% (Sexton + OT)	\$ 262.00	\$ 282.00	\$ 282.00	\$ 282.00
31	School & Prof.	\$ 325.00	\$ 300.00	\$ 150.00	\$ 150.00
32	Legal Fees - Foundation / Land	\$ 983.00	\$ 500.00	\$ 250.00	\$ 250.00
33	Eng. Fee - Road	\$ -	\$ 300.00	\$ -	\$ -
34	Recording Fees	\$ 162.00	\$ 90.00	\$ 90.00	\$ 90.00
35	City Gas - N section mowing	\$ 1,373.00	\$ 615.00	\$ 685.00	\$ 750.00
36	Publication: flyers, mow notice	\$ 134.00	\$ 300.00	\$ 140.00	\$ 300.00
37	Insurance (Liab. & ? mower)	\$ 221.00	\$ 550.00	\$ 550.00	\$ 700.00
38	Public Utility	\$ 544.00	\$ 510.00	\$ 400.00	\$ 500.00
39	City Lights - N Well Directory	\$ 247.00	\$ 230.00	\$ 249.00	\$ 250.00
40	Util. R & M	\$ 640.00	\$ 1,000.00	\$ 1,598.00	\$ 1,000.00
41	Perpetual Care	\$ 2,612.00	\$ 1,000.00	\$ 1,000.00	\$ 1,000.00
42	Niche Engraving	\$ -	\$ -	\$ 165.00	\$ 450.00
43	Gravel / Crush Concrete	\$ -	\$ -	\$ -	\$ -
44	Elmwood Bench (3x\$500)	\$ -	\$ 1,300.00	\$ -	\$ 1,500.00
45	Bldg R&M: garb \$150 (3x\$50)	\$ 265.00	\$ 600.00	\$ 100.00	\$ 150.00
46	Grounds - spray, seed, stumps	\$ 462.00	\$ 500.00	\$ 600.00	\$ 500.00

1	AMBULANCE #11	17-18 Actual	18-19 Budget	18-19 Estimate	19-20 Budget
2	REVENUE				
3	Refunds - Rural Fire 1/2 Disb.	\$ 8,241.00	\$ 13,825.00	\$ 13,825.00	\$ 13,925.00
4	Int. (505003 + 3 CD's) ? Purchase	\$ 3,429.00	\$ 2,700.00	\$ 3,512.00	\$ 3,300.00
5	Collection - EMT Runs	\$ 39,972.00	\$ 46,000.00	\$ 46,000.00	\$ 46,000.00
6	Ambulance 505003	\$ -	\$ -	\$ -	\$ -
7	St Paul Rescue Pers Acct	\$ -	\$ -	\$ -	\$ -
8	St. Paul Rural Fire	\$ -	\$ -	\$ -	\$ -
9	Sell 1997 Ambul.- \$10,000	\$ -	\$ -	\$ -	\$ -
10	TOTAL REVENUES	\$ 51,642.00	\$ 62,525.00	\$ 63,337.00	\$ 63,225.00
11					
12	EXPENSE				
13	PERSONNEL SERVICES				
14	Wages (EMT Trfrs - \$15)	\$ -	\$ 750.00	\$ -	\$ 750.00
15	Insurance (United Life)	\$ 1,812.00	\$ 3,000.00	\$ 1,709.00	\$ 3,000.00
16	OPERATING EXPENSE				
17	Prof. & Schools - Kult, Swanson	\$ 6,190.00	\$ 7,000.00	\$ 3,800.00	\$ 7,000.00
18	City Gas & Oil	\$ 452.00	\$ 1,000.00	\$ 600.00	\$ 1,000.00
19	Insurance (Liability)	\$ 1,978.00	\$ 2,000.00	\$ 2,000.00	\$ 2,200.00
20	Vehicle R & M	\$ 3,116.00	\$ 2,000.00	\$ 750.00	\$ 2,000.00
21	EMS Billing (15%)	\$ 5,588.00	\$ 6,900.00	\$ 6,900.00	\$ 6,900.00
22	Rural Fire Reimb. (1/2 of Runs)	\$ 16,990.00	\$ 23,000.00	\$ 27,926.00	\$ 23,000.00
23	Merch /Supplies (Unit)	\$ 4,425.00	\$ 5,000.00	\$ 2,000.00	\$ 5,000.00
24	CAPITAL OUTLAY				
25	Equip. Purch. - Ambulance	\$ -	\$ -	\$ -	\$ -
26	Equipment Sinking	\$ 9,000.00	\$ 9,000.00	\$ 9,000.00	\$ 9,000.00
27	DEBT SERVICE				
28	Principal (Loan)	\$ -	\$ -	\$ -	\$ -
29	Interest (Loan)	\$ -	\$ -	\$ -	\$ -
30	TOTAL EXPENDITURES	\$ 49,551.00	\$ 59,650.00	\$ 54,685.00	\$ 59,850.00
31					
32	NET ANNUAL CASH FLOW	\$ 2,091.00	\$ 2,875.00	\$ 8,652.00	\$ 3,375.00
***	M. Mmkt #505003 - \$38,833				
	Time CD's = \$121,155				
	ICS = \$129,210				
***	1997 Ford \$84,500				
	2006 Ford \$122,000				
***	New Ambulance estimated at \$275,000				
***	Excess Money for 2014-2015 = \$10,696.00				
	Excess Money for 2015-2016 = \$17,446.00				
	Excess Money for 2016-2017 = \$23,220				
	Excess Money for 2017-2018 = \$11,132				

1	POOL #12	17-18 Actual	18-19 Budget	18-19 Estimate	19-20 Budget
2	REVENUE				
3	Property Tax	\$ 51,636.00	\$ 52,000.00	\$ 52,000.00	\$ 52,000.00
4	Admissions - INCREASE	\$ 31,990.00	\$ 25,000.00	\$ 25,000.00	\$ 25,000.00
5	Interest - 504442	\$ 45.00	\$ -	\$ 57.00	\$ -
6	Transfer from Lights	\$ -	\$ -	\$ -	\$ -
7	Concessions	\$ 6,994.00	\$ 7,500.00	\$ 7,000.00	\$ 7,000.00
8	Swim Lessons	\$ 3,800.00	\$ 3,000.00	\$ 3,000.00	\$ 3,000.00
9	Reimb:	\$ 248.00	\$ -	\$ 346.00	\$ -
10	KENO: deck \$11,510; wtr heater	\$ -	\$ -	\$ -	\$ 13,610.00
11	\$1,500, chair platform \$600				
12	Sales Tax	\$ 2,294.00	\$ 2,500.00	\$ 2,300.00	\$ 2,300.00
13	TOTAL REVENUES	\$ 97,007.00	\$ 90,000.00	\$ 89,703.00	\$ 102,910.00
14	EXPENSE				
15	PERSONNEL SERVICES				
16	Salary & Wages	\$ 39,793.00	\$ 42,500.00	\$ 41,500.00	\$ 42,500.00
17	Fica - 6.20%	\$ 2,467.00	\$ 2,635.00	\$ 2,573.00	\$ 2,635.00
18	Medicare - 1.45%	\$ 577.00	\$ 616.00	\$ 602.00	\$ 616.00
19	OPERATING EXPENSE				
20	Prof & Sch - CPR, Bonus, Train, WSI	\$ 2,311.00	\$ 2,600.00	\$ 2,400.00	\$ 2,600.00
21	Adm. & Dues - Permit	\$ 40.00	\$ 100.00	\$ 40.00	\$ 100.00
22	Eng Fees: No slide deck eng.	\$ -	\$ -	\$ -	\$ -
23	Communication - Static IP	\$ 37.00	\$ -	\$ 70.00	\$ 70.00
24	Insurance (Liability) 10%	\$ 6,454.00	\$ 7,000.00	\$ 7,000.00	\$ 7,700.00
25	City Lights	\$ 4,972.00	\$ 5,200.00	\$ 4,500.00	\$ 5,200.00
26	Blackhills Gas	\$ 1,951.00	\$ 5,000.00	\$ 4,000.00	\$ 5,000.00
27	Uniforms	\$ 531.00	\$ 900.00	\$ 774.00	\$ 900.00
28	Util R & M (Burst pipe, TP, towels)	\$ 3,377.00	\$ 3,600.00	\$ 2,500.00	\$ 3,000.00
29	Tools - clock, pass, tape	\$ 8.00	\$ 100.00	\$ 14.00	\$ 100.00
30	Chemicals	\$ 4,843.00	\$ 5,000.00	\$ 6,405.00	\$ 5,000.00
31	Petty Cash - Concession Startup	\$ 150.00	\$ 150.00	\$ 125.00	\$ 210.00
32	Sales Tax - Form 10	\$ 2,413.00	\$ 2,500.00	\$ 2,450.00	\$ 2,500.00
33	Concessions - Coke,	\$ 3,860.00	\$ 4,500.00	\$ 3,900.00	\$ 4,500.00
34	Thomp, Schwans				
35	Bldg. R&M -Garb, paint, valve,	\$ 668.00	\$ 250.00	\$ 250.00	\$ 250.00
36	shingles				
37	CAPITAL OUTLAY				
38	Improve: deck \$11,510; wtr heater	\$ -	\$ -	\$ -	\$ 13,610.00
39	\$1,500, chair platform \$600				
40	Pool Equip. Sinking	\$ -	\$ 7,000.00	\$ 7,000.00	\$ 6,000.00
41	DEBT SERVICE				
42	Pool Debt Service in VP Bond 61				
43	TOTAL EXPENDITURES	\$ 74,452.00	\$ 89,651.00	\$ 86,103.00	\$ 102,491.00
44	NET ANNUAL CASH FLOW	\$ 22,555.00	\$ 349.00	\$ 3,600.00	\$ 419.00
***	Pool Savings 504442 = \$7,006				

***	Pool Heater is \$25,000 + Labor (new in 2002) use only 2 1/2 mths out of year				
	2014 \$3,060 Keno for Pool Slide finish				
	2015 Carkoski repaired pool leak				
	2016 Carkoski repaired pool deck				
	2017 Steele Pool Co. Pool Painting \$69,054 (\$55,000 Pool Budget & \$14,054 Keno Fund)				
	2019-2020 Slide Deck \$11510, Water Heater \$1500, Chair Platform \$600				
	PAGE 12				

1	PARK #13	17-18 Actual	18-19 Budget	18-19 Estimate	19-20 Budget
2	REVENUE				
3	Property Tax	\$ 54,663.00	\$ 55,000.00	\$ 55,000.00	\$ 55,000.00
4	Ho Co Found: \$20000 Batting Cage	\$ 19,671.00	\$ -	\$ -	\$ -
5	Donations: \$20,000 Summer Ball	\$ 6,000.00	\$ -	\$ -	\$ -
6	Fee, Tennis Crt Meter	\$ 19.00	\$ 17.00	\$ -	\$ -
7	Interest - 505025 + 1 CD	\$ 1,207.00	\$ 500.00	\$ 2,000.00	\$ 1,500.00
8	Bench - Harrahill	\$ 552.00	\$ -	\$ -	\$ -
9	Transfer In from Lights	\$ 66,800.00	\$ 66,800.00	\$ 66,800.00	\$ 66,800.00
10	Grant:	\$ 4,200.00	\$ -	\$ 500.00	\$ -
11	Reimb: cond. freight, chalk, planks	\$ 2,007.00	\$ 1,550.00	\$ 6,722.00	\$ 1,550.00
12	Reserve -#505025	\$ -	\$ -	\$ -	\$ -
13	TOTAL REVENUES	\$ 155,119.00	\$ 123,867.00	\$ 131,022.00	\$ 124,850.00
14					
15	EXPENSE				
16	PERSONNEL SERVICES				
17	Salary/Wages - Randy	\$ 43,018.00	\$ 43,431.00	\$ 43,794.00	\$ 44,741.00
18	Overtime (ballfields & GCA Days)	\$ 2,426.00	\$ 2,000.00	\$ 1,650.00	\$ 2,000.00
19	Fica - 6.20%	\$ 2,599.00	\$ 2,817.00	\$ 2,818.00	\$ 2,898.00
20	Medicare - 1.45%	\$ 608.00	\$ 659.00	\$ 659.00	\$ 678.00
21	Pension 6%	\$ 2,727.00	\$ 2,726.00	\$ 2,726.00	\$ 2,804.00
22	Ins: Health 12%, Woodm, Life, &	\$ 20,403.00	\$ 20,602.00	\$ 20,617.00	\$ 26,232.00
23	Health Ded.				
24	OPERATING EXPENSE				
25	Prof & Schools - Turf & Chemical	\$ 606.00	\$ 900.00	\$ 200.00	\$ 900.00
26	Communication - Static IP	\$ 37.00	\$ -	\$ 70.00	\$ 70.00
27	City Gas & Oil - Rec Trail	\$ 4,226.00	\$ 3,000.00	\$ 3,300.00	\$ 3,500.00
28	Insurance 10% (Liab & mower)	\$ 9,334.00	\$ 9,963.00	\$ 10,023.00	\$ 10,959.00
29	City Lights	\$ 4,980.00	\$ 6,500.00	\$ 5,700.00	\$ 6,500.00
30	Uniforms	\$ 260.00	\$ 300.00	\$ 302.00	\$ 300.00
31	Util R & M: shelter ceil \$800,	\$ 6,958.00	\$ 7,000.00	\$ 6,000.00	\$ 7,000.00
32	bench \$500				
33	Veh. R & M:	\$ 1,221.00	\$ 1,200.00	\$ 1,100.00	\$ 1,200.00
34	Tools - Trimmer	\$ 38.00	\$ 500.00	\$ 403.00	\$ 500.00
35	Bldg R & M: Garb, door \$500,	\$ 1,814.00	\$ 2,000.00	\$ 1,500.00	\$ 2,000.00
36	(2) chg tables \$364				
37	Grounds - fert, sprinkler, lava,	\$ 19,163.00	\$ 11,700.00	\$ 9,115.00	\$ 11,700.00
38	seed , chemicals, chalk, cond.,				
39	CAPITAL OUTLAY				
40	Mach & Eq: (3) cameras Batting	\$ 258.00	\$ 8,800.00	\$ 8,860.00	\$ 4,000.00
41	Cage \$2500				
42	Improve:	\$ -	\$ -	\$ -	\$ -
43	Equipment Sinking	\$ 5,000.00	\$ 2,500.00	\$ 2,500.00	\$ -
44	DEBT SERVICE				
45	TOTAL EXPENDITURES	\$ 125,676.00	\$ 126,598.00	\$ 121,337.00	\$ 127,982.00
46					

47	NET ANNUAL CASH FLOW	\$ 29,443.00	\$ (2,731.00)	\$ 9,685.00	\$ (3,132.00)
***	Time CD = \$41,506				
	M. Mkt 505025 = \$48,587				
	ICS = \$68,963				
***	Ball Assoc. pays for 1 pallet of turf, 1/2 pallet chalk and 1/2 of freight				
	School pays 1/2 pallet of conditioner & chalk				
	2015-2016 Purchase Seeder with School \$2,000				
	2017 Ranger Polaris Gator Purchased \$5,500				
	2018-2019 Ranger Blade & Canopy \$2350 - Kearney Power Sports				
	2018-2019 Changing Tables in Womens Restroom				
	PAGE 13				

1	LIBRARY #15	17-18 Actual	18-19 Budget	18-19 Estimate	19-20 Budget
2	REVENUE				
3	Property Tax	\$ 75,314.00	\$ 76,000.00	\$ 76,000.00	\$ 76,000.00
4	Library State Aid	\$ 928.00	\$ -	\$ 906.00	\$ 900.00
5	Refunds-Larm & School Bills	\$ 18,333.00	\$ 30,800.00	\$ 27,797.00	\$ 31,160.00
6	Int. (504-970)	\$ 55.00	\$ 10.00	\$ 120.00	\$ -
7	Maintenance Reserve	\$ 5,000.00	\$ 2,500.00	\$ 5,000.00	\$ 2,500.00
8	Reimburse (Ebsco Magazines)	\$ 118.00	\$ -	\$ 582.00	\$ -
9	TOTAL REVENUES	\$ 99,630.00	\$ 109,310.00	\$ 110,405.00	\$ 110,560.00
10					
11	EXPENSE				
12	PERSONNEL SERVICES				
13	Salary & Wages 3%	\$ 26,850.00	\$ 33,500.00	\$ 33,500.00	\$ 33,500.00
14	Fica - 6.20%	\$ 1,665.00	\$ 2,077.00	\$ 2,077.00	\$ 2,077.00
15	Medicare - 1.45%	\$ 389.00	\$ 486.00	\$ 486.00	\$ 486.00
16	OPERATING EXPENSE				
17	Janitor / Maintenance	\$ 9,000.00	\$ 9,000.00	\$ 9,000.00	\$ 9,000.00
18	Prof. & Schools	\$ 1,885.00	\$ 1,700.00	\$ 900.00	\$ 1,500.00
19	Communication	\$ 320.00	\$ 400.00	\$ 325.00	\$ 400.00
20	Magazine & Paper	\$ 2,030.00	\$ 2,000.00	\$ 1,900.00	\$ 1,800.00
21	Books / E-Books	\$ 24,520.00	\$ 27,500.00	\$ 25,500.00	\$ 28,000.00
22	Insurance (Liability) 10%	\$ 7,002.00	\$ 7,200.00	\$ 7,200.00	\$ 7,920.00
23	City Lights	\$ 7,523.00	\$ 8,500.00	\$ 7,750.00	\$ 8,500.00
24	Blackhills Gas	\$ 2,741.00	\$ 3,500.00	\$ 3,100.00	\$ 3,500.00
25	Util. R & M- HVAC 820, Gutters	\$ 1,135.00	\$ 1,300.00	\$ 1,000.00	\$ 1,200.00
26	Computer	\$ 1,734.00	\$ 2,000.00	\$ 1,300.00	\$ 1,500.00
27	Office Supply: copier \$600 yr	\$ 3,216.00	\$ 3,000.00	\$ 2,980.00	\$ 3,000.00
28	Program Expense	\$ 1,145.00	\$ 1,500.00	\$ 1,450.00	\$ 2,000.00
29	Accounting Fee	\$ 1,000.00	\$ 1,000.00	\$ 1,000.00	\$ 1,000.00
30	CAPITAL OUTLAY				
31	Equip. Reserve (to Savings)	\$ 2,500.00	\$ 2,500.00	\$ 2,500.00	\$ 2,500.00
32	Improve:	\$ -	\$ 2,000.00	\$ 1,188.00	\$ 2,000.00
33	TOTAL EXPENDITURES	\$ 94,655.00	\$ 109,163.00	\$ 103,156.00	\$ 109,883.00
34	NET ANNUAL CASH FLOW	\$ 4,975.00	\$ 147.00	\$ 7,249.00	\$ 677.00
	M. Mkt #504970 = \$40,265				
***	2016 New Rheem Unit 2016		Line 5 total: add all expenditures except for		
***	2017 New Desk		wages, janitor & equip. reserve.		
***	2017 Spray Roof - 10 Year Warranty				
***	2019 Bistro Tables				
***	School Fiscal Yr = August 1				
	PAGE 15				

1	PROGRAM INCOME #17	17-18 Actual	18-19 Budget	18-19 Estimate	19-20 Budget
2	REVENUE				
3	Housing Grant Loan Pymts	\$ 1,776.00	\$ 188.00	\$ 588.00	\$ 154.00
4					
5	TOTAL REVENUES	\$ 1,776.00	\$ 188.00	\$ 588.00	\$ 154.00
6					
7	EXPENSE				
8	OPERATING EXPENSE				
9	Parkside Plaza North	\$ 1,845.00	\$ 600.00	\$ 687.00	\$ 154.00
10	TOTAL EXPENDITURES	\$ 1,845.00	\$ 600.00	\$ 687.00	\$ 154.00
11					
12	NET ANNUAL CASH FLOW	\$ (69.00)	\$ (412.00)	\$ (99.00)	\$ -
***	Savings #41780 = \$540				
	Housing Authority to Utilize Proceeds				
	PAGE 16				

1	SALES TAX #18	17-18 Actual	18-19 Budget	18-19 Estimate	19-20 Budget
2	REVENUE				
3	Int. (504420 + CD 108847 &	\$ 2,792.00	\$ 1,900.00	\$ 2,600.00	\$ 1,900.00
4	300277, Infrast. 102342)				
5	25% Sales Tax - Infrastructure	\$ 73,627.00	\$ 69,682.00	\$ 70,000.00	\$ 68,000.00
6	LB840 Princ.	\$ 81,559.00	\$ 56,821.00	\$ 67,000.00	\$ 57,062.00
7	LB840 Interest	\$ 9,816.00	\$ 8,973.00	\$ 9,075.00	\$ 10,038.00
8	LB840 Fines	\$ 280.00	\$ -	\$ 120.00	\$ -
9	Grant (DTR)	\$ 1,000.00	\$ -	\$ 31,400.00	\$ -
10	Sales Tax Proceeds	\$ 220,881.00	\$ 216,000.00	\$ 210,000.00	\$ 203,200.00
11	TOTAL REVENUES	\$ 389,955.00	\$ 353,376.00	\$ 390,195.00	\$ 340,200.00
12	OPERATING EXPENSE				
13	Legal (Blight, DTR, Mainstreet Pl	\$ 545.00	\$ 500.00	\$ 258.00	\$ 500.00
14	Marketing (Chamber) \$9,000	\$ 5,000.00	\$ 5,000.00	\$ 9,000.00	\$ 9,000.00
15	Check Order 300277	\$ -	\$ 25.00	\$ 12.00	\$ 25.00
16	Accounting - Dana Cole	\$ 1,850.00	\$ 1,850.00	\$ 1,850.00	\$ 1,850.00
17	CAPITAL OUTLAY				
18	Improvements: Mid Loup Subd. &	\$ 143,860.00	\$ 1,015,727.00	\$ 400,000.00	\$ 814,399.00
19	ALL Improvements (per auditors)				
20	Grant- Annex Housing Auth.	\$ 11,000.00	\$ -	\$ -	\$ -
21	DEBT SERVICE				
22	Trfr Out - Civic Loan Pymt	\$ -	\$ 75,000.00	\$ 46,087.00	\$ 75,000.00
23	Trfr Out -Wtr Mid Loup Bond Pyt	\$ -	\$ -	\$ -	2020-2021
24	Trfr Out - Swr Mid Loup Bond Pyt	\$ -	\$ -	\$ -	2020-2021
25	Trfr Out- Str Mid Loup Bond Pyt	\$ -	\$ -	\$ -	2020-2021
26	Eco. Dev.	\$ 117,000.00	\$ 117,000.00	\$ 117,000.00	\$ 117,000.00
27	TOTAL EXPENDITURES	\$ 279,255.00	\$ 1,215,102.00	\$ 573,949.00	\$ 1,017,774.00
28					
29	NET ANNUAL CASH FLOW	\$ 110,700.00	\$ (861,726.00)	\$ (183,754.00)	\$ (677,574.00)
***	M. Mkt #504420 = \$117,623				
	Sav. #102-342 (Infrast.) = \$231,509				GIS - from 25% Infrastructure Fund = June 2018
	Ckg Int #300277 = \$35,419				
	Time CD's = \$78,536				
***	Middle Loup Subd Estimate \$1,662,600				
***	LB840 Loans Open	Outstanding	Pymt Amount		
	L & M Adventures - Barth 2%	\$ 122,267.00	\$ 1,933.00	Increased Loan \$120,000 (April 2015)	
	Love It! Salon (Default 2018)	\$ 4,880.00	\$ -	With UCC Items Sold	
	U-Betcha Auto 2%	\$ 42,337.00	\$ 1,150.00		
	Housing Authority 2%	\$ -	\$ -	Paid in Full 10-2018	
	Herv's Transmission 2.85%	\$ 110,244.00	\$ 908.92	Addition (Jan) to Loan \$31,350	
	Augy's Fitness 2%	\$ 58,597.00	\$ 715.00		
	Northup Siding 2.70%	\$ 5,557.00	\$ 116.00		
	Escape Tan 2.75%	\$ 7,521.00	\$ 155.00		

Bed Head Coffee	2.75	\$ 94,298.00	\$ 649.00		
Grand Total		\$ 445,701.00	\$ 5,626.92		
PAGE 18					

1	St. Paul Civic Center / Recreation	17-18 Actual	18-19 Budget	18-19 Estimate	19-20 Budget
2	#21				
3	REVENUE				
4	Property Tax - Civic (Recreation)	\$ 7,288.00	\$ 8,000.00	\$ 8,000.00	\$ 8,000.00
5	Registration Fee - Recreation	\$ 4,445.00	\$ 5,000.00	\$ 6,000.00	\$ 6,000.00
6	League, Pickle Ball, & Classes				
7	Donation - Civic	\$ 102,485.00	\$ 10,000.00	\$ 12,425.00	\$ 10,000.00
8	Membership - Civic	\$ 9,561.00	\$ 5,500.00	\$ 6,700.00	\$ 5,500.00
9	Rentals - Civic	\$ 31,998.00	\$ 25,000.00	\$ 25,000.00	\$ 25,000.00
10	SPDC Office Rental - Civic	\$ 6,000.00	\$ 6,200.00	\$ 6,000.00	\$ 6,000.00
11	(utilities & office Space)				
12	Interest - CIVIC - 300749	\$ 13.00	\$ 5.00	\$ 22.00	\$ 15.00
13	Reimb - Adult League, LARM	\$ 600.00	\$ -	\$ 424.00	\$ -
14	Grant: Christensen/Sonderup	\$ 5,000.00	\$ 500.00	\$ -	\$ -
15	Sales Tax - Adult Sport League	\$ -	\$ -	\$ -	\$ 100.00
16	Transfer In: Sale Tax: Civic	\$ -	\$ 75,000.00	\$ 46,087.00	\$ 75,000.00
17	Bldg Loan \$75,000	\$ -			
18	TOTAL REVENUES	\$ 167,390.00	\$ 135,205.00	\$ 110,658.00	\$ 135,615.00
19	EXPENSE				
20	PERSONAL SERVICES				
21	Wages - RECREATION	\$ -	\$ 6,200.00	\$ 6,200.00	\$ 6,200.00
22	Recreation Class Instructors	\$ 3,050.00	\$ 2,800.00	\$ 3,200.00	\$ 3,200.00
23	OPERATING EXPENSE				
24	Janitor / Maint - Civic	\$ 2,400.00	\$ 2,400.00	\$ 4,420.00	\$ 4,420.00
25	Recreation Supplies			\$ 2,038.00	\$ 1,700.00
26	Legal - CIVIC	\$ 223.00	\$ 200.00	\$ -	\$ 200.00
27	Publish: REC 66-20-235	\$ 122.00	\$ 225.00	\$ -	\$ 225.00
28	Publish: Civic 66-20-240	\$ 724.00	\$ 550.00	\$ 27.00	\$ 550.00
29	Insurance (liability) Civic	\$ 9,995.00	\$ 10,000.00	\$ 10,000.00	\$ 11,000.00
30	City Lights / LED = Civic	\$ 11,600.00	\$ 15,000.00	\$ 13,000.00	\$ 15,000.00
31	Utility R & M - Civic: Entech	\$ 9,155.00	\$ 3,000.00	\$ 3,507.00	\$ 3,000.00
32	Sales Tax - Adult Sport League	\$ 134.00	\$ 100.00	\$ -	\$ 100.00
33	Check Order - Civic	\$ 19.00	\$ -	\$ -	\$ 25.00
34	Merch& Sup: Civic \$3500	\$ 6,879.00	\$ 3,500.00	\$ 3,300.00	\$ 3,500.00
35	Sanitation Hauling - Civic	\$ 960.00	\$ 1,200.00	\$ 960.00	\$ 1,200.00
36	Accounting Fee - Civic	\$ 400.00	\$ 200.00	\$ 200.00	\$ 200.00
37	Reimb Pd:rotary junk jaunt, River	\$ 6,540.00	\$ -	\$ -	\$ -
38	of Life marriage conf, etc.				
39	Grant:	\$ 5,000.00	\$ 500.00	\$ -	\$ -
40	CAPITAL OUTLAY				
41	Improve: Loan 75,000, paint	\$ 110,000.00	\$ 84,000.00	\$ 64,087.00	\$ 80,000.00
42	Sinking: Civic Center	\$ -	\$ 5,000.00	\$ 5,000.00	\$ 5,000.00
43	TOTAL EXPENDITURES	\$ 167,201.00	\$ 134,875.00	\$ 115,939.00	\$ 135,520.00
44	NET ANNUAL CASH FLOW	\$ 189.00	\$ 330.00	\$ (5,281.00)	\$ 95.00

***	Civic Ctr 300749 = \$15,419					
	Civic Ctr Sinking #505179 - \$10,508					
	PAGE 21					

1	TIF #22	17-18 Actual	18-19 Budget	18-19 Estimate	19-20 Budget
2	REVENUE				
3	TIF Proceeds: MAD Dev.	\$ -	\$ 6,013.00	\$ -	\$ -
4	TIF Proceeds: Prairie Falls	\$ 1,578.00	\$ 3,200.00	\$ -	\$ -
5					
6	Prairie Fall #8652 - Johnson	\$ 1,443.00	\$ -	\$ 3,050.00	\$ 3,050.00
7	Lots 15 & 16				
8	MAD Dev. #8653 - Taylor	\$ 548.00	\$ -	\$ 5,465.00	\$ 5,465.00
9	Lot 13				
10	MAD Dev. #8654 - Solko	\$ 562.00	\$ -	\$ 4,847.00	\$ 4,847.00
11	Lot 16				
12	MAD Dev #8655 - Levander	\$ -	\$ -	\$ 2,757.00	\$ 5,500.00
13	Lot 14				
14	MAD Dev #8656 - Wells, C	\$ -	\$ -	\$ 3,452.00	\$ 3,800.00
15	Lot 18				
16	Prairie Falls #8657 - Ross B	\$ -	\$ -	\$ 654.00	\$ 1,308.00
17	Lots 13 & 14				
18	MAD Dev. #8658 - Robinson	\$ -	\$ -	\$ 2,772.00	\$ 5,512.00
19	Lot 4				
20	Prairie Fall #8659 Sok M	\$ -	\$ -	\$ 872.00	\$ 3,800.00
21	Lots 11 & 12				
22	MAD Dev #8660 - Robinson	\$ -	\$ -	\$ -	\$ 2,000.00
23	Lot 3				
24	Bed Head Coffee #8661	\$ -	\$ -	\$ -	\$ 200.00
25	Lot 9-13, Blk 78, O.T.				
26	Prairie Fall #8662 - Larsen	\$ -	\$ -	\$ -	\$ 2,000.00
27	Lot 2, Blk 3, Harris				
28	Interest #505036	\$ 31.00	\$ -	\$ 3.00	\$ -
29	TOTAL REVENUES	\$ 4,162.00	\$ 9,213.00	\$ 23,872.00	\$ 37,482.00
30	OPERATING EXPENSE				
31	TIF Check Order 68-20-306	\$ -	\$ -	\$ 12.00	\$ 12.00
32	MAD DEV (50/50)	\$ 290.00	\$ 1,503.00	\$ 5,169.00	\$ 13,562.00
33	68-20-009				
34	CITY (MAD) (50/50)	\$ 290.00	\$ 1,503.00	\$ 5,169.00	\$ 13,562.00
35	68-20-008				
36	All Proceeds to Prairie	\$ 1,578.00	\$ 3,200.00	\$ -	\$ -
37	Falls 68-60-016				
38	Prairie Fall #8652 Johnson	\$ -	\$ -	\$ 3,001.00	\$ 3,050.00
39	Lots 15 & 16				
40	Prairie Falls #8657 - Ross B	\$ -	\$ -	\$ 654.00	\$ 1,308.00
41	Lots 13 & 14				
42	Prairie Fall #8659 Sok M	\$ -	\$ -	\$ 436.00	\$ 3,800.00
43	Lots 11 & 12				
44	Bed Head Coffee #8661	\$ -	\$ -	\$ -	\$ 200.00
45	Lots 9-13, Blk 78 O.T.				
46					

47	Prairie Fall #8662 - Larsen	\$ -	\$ -	\$ -	\$ 2,000.00
48	Lot 2, Blk 3, Harris				
49	TOTAL EXPENDITURES	\$ 2,158.00	\$ 6,206.00	\$ 14,441.00	\$ 37,494.00
50	NET ANNUAL CASH FLOW	\$ 2,004.00	\$ 3,007.00	\$ 9,431.00	\$ (12.00)
***	M Mkt #505036 = \$942.00				
	MAD DEVELOPMENT				
1	Series A (City) = \$290,000 (Water/ Sewer Construction, Engineering \$30,000, Attorney, Recording, Publ)				
2	Series B (Redeveloper) = \$424,000 at 7.50%				
	50 / 50 (CDA & Redeveloper)				
	Starostka Construction Bid = \$226,398.95 for City Infrastructure				
	ATTORNEY WILLIS = 402/474-6900				
3	PRAIRIE FALLS Phase 1 - Diane Johnson				
	NOTICE TO DIVIDE: 7-19-2016				
	Prairie Falls Subdivision: Proceeds in June / Dec				
	Interest starts 7/6/2016 at 5% on \$30,000				
4	PRAIRIE FALLS Phase 2 - Ramiro Mendez				
	NOTICE to DIVIDE: 7-26-17				
	Prairie Falls Subdivision: Proceeds in June / Dec				
	Interest starts 8-7-17 at 5% on \$30,000				
5	PRAIRIE FALLS Phase 3 - Mike Sok				
	NOTICE to DIVIDE: 9-8-2017				
	Prairie Falls Subdivision: Proceeds in June / Dec				
	Interest starts 10-16-17 at 5% on \$30,000				
6	PRAIRIE FALLS Phase 4 - Corey & Tara Larsen				
	NOTICE to DIVIDE: 3-26-2018				
	Prairie Falls Subdivision: Proceeds in June / Dec				
	Interest starts 3-18-19 at 5% on \$30,910				
7	BED HEAD COFFEE (Megan Yutesler)				
	NOTICE TO DIVIDE: 3-25-2018				
	Proceeds in June / Dec				
	Interest starts 12-17-2019				
	\$55,000 at 4.5%				
	PAGE 22				

1	Senior Center #23	17-18 Actual	18-19 Budget	18-19 Estimate	19-20 Budget
2	REVENUE				
3	Property tax	\$ 6,678.00	\$ 8,000.00	\$ 8,000.00	\$ 8,000.00
4	Int. 504882 (may utilize)	\$ 80.00	\$ 20.00	\$ 85.00	\$ 20.00
5	TOTAL REVENUES	\$ 6,758.00	\$ 8,020.00	\$ 8,085.00	\$ 8,020.00
6					
7	EXPENSE				
8	OPERATING EXPENSE				
9	Insurance (Liability)	\$ 1,650.00	\$ 1,800.00	\$ 1,800.00	\$ 1,980.00
10	Bldg.R&M - HVAC maint.	\$ 240.00	\$ 2,000.00	\$ 700.00	\$ 2,000.00
11	Building Sinking	\$ 4,000.00	\$ 4,000.00	\$ 4,000.00	\$ 4,000.00
12	TOTAL EXPENDITURES	\$ 5,890.00	\$ 7,800.00	\$ 6,500.00	\$ 7,980.00
13					
14	NET ANNUAL CASH FLOW	\$ 868.00	\$ 220.00	\$ 1,585.00	\$ 40.00
	M Mkt #504882 = \$36,136				
***	Opened in 1988				
	2012 Roof Construction				
	2013 Insulated & New Windows in 2013				
	2014 New Furnace / Air Transferred from General 504684 = \$16,136.00				
	2017 Clean / Repair Furnace				
	PAGE 23				

**2019-2020
STATE OF NEBRASKA
CITY/VILLAGE BUDGET FORM**

City of St. Paul
TO THE COUNTY BOARD AND COUNTY CLERK OF
Howard County

This budget is for the Period October 1, 2019 through September 30, 2020

Upon Filing, The Entity Certifies the Information Submitted on this Form to be Correct:

The following **PERSONAL AND REAL PROPERTY TAX** is requested for the ensuing year:

\$	631,250.00	Property Taxes for Non-Bond Purposes
\$	202,000.00	Principal and Interest on Bonds
\$	833,250.00	Total Personal and Real Property Tax Required

Projected Outstanding Bonded Indebtedness as of October 1, 2019
(As of the Beginning of the Budget Year)

Principal	\$	3,555,000.00
Interest	\$	463,474.00
Total Bonded Indebtedness	\$	4,018,474.00

\$ 127,104,101 **Total Certified Valuation (All Counties)**
*(Certification of Valuation(s) from County Assessor **MUST** be attached)*

Report of Joint Public Agency & Interlocal Agreements

Was this Subdivision involved in any Interlocal Agreements or Joint Public Agencies for the reporting period of July 1, 2018 through June 30, 2019?

YES NO

If YES, Please submit Interlocal Agreement Report by September 20th.

County Clerk's Use ONLY

Report of Trade Names, Corporate Names & Business Names

Did the Subdivision operate under a separate Trade Name, Corporate Name, or other Business Name during the period of July 1, 2018 through June 30, 2019?

YES NO

If YES, Please submit Trade Name Report by September 20th.

APA Contact Information

Auditor of Public Accounts
State Capitol, Suite 2303
Lincoln, NE 68509

Telephone: (402) 471-2111 FAX: (402) 471-3301

Website: www.auditors.nebraska.gov

Questions - E-Mail: Deann.Haeffner@nebraska.gov

Submission Information

Budget Due by 9-20-2019

Submit budget to:

1. Auditor of Public Accounts -Electronically on Website or Mail
2. County Board (SEC. 13-508), C/O County Clerk

City of St. Paul in Howard County

Line No.	Beginning Balances, Receipts, & Transfers	Actual 2017 - 2018 (Column 1)	Actual/Estimated 2018 - 2019 (Column 2)	Adopted Budget 2019 - 2020 (Column 3)
1	Net Cash Balance	\$ 3,788,455.00	\$ 4,336,657.00	\$ 4,705,597.00
2	Investments	\$ 2,219,791.00	\$ 1,234,677.00	\$ 1,200,000.00
3	County Treasurer's Balance	\$ 36,142.00	\$ 46,213.00	\$ 45,000.00
4	Beginning Balance Proprietary Function Funds (Only If Page 6 is Used)			\$ -
5	Subtotal of Beginning Balances (Lines 1 thru 4)	\$ 6,044,388.00	\$ 5,617,547.00	\$ 5,950,597.00
6	Personal and Real Property Taxes (Columns 1 and 2 - See Preparation Guidelines)	\$ 813,543.00	\$ 845,425.00	\$ 825,000.00
7	Federal Receipts	\$ -	\$ 300,500.00	\$ 700,000.00
8	State Receipts: Motor Vehicle Pro-Rate	\$ 2,439.00	\$ 1,000.00	\$ 1,000.00
9	State Receipts: MIRF	\$ -	\$ -	\$ -
10	State Receipts: Highway Allocation and Incentives	\$ 294,137.00	\$ 314,916.00	\$ 322,245.00
11	State Receipts: Motor Vehicle Fee	\$ 23,325.00	\$ 20,000.00	\$ 20,000.00
12	State Receipts: State Aid	\$ -	\$ -	
13	State Receipts: Municipal Equalization Aid	\$ 102,328.00	\$ 82,452.00	\$ 102,054.00
14	State Receipts: Other	\$ 65,715.00	\$ -	\$ -
15	State Receipts: Property Tax Credit	\$ 42,705.00	\$ -	
16	Local Receipts: Nameplate Capacity Tax	\$ -	\$ -	\$ -
17	Local Receipts: Motor Vehicle Tax	\$ 43,241.00	\$ 42,000.00	\$ 42,000.00
18	Local Receipts: Local Option Sales Tax	\$ 336,801.00	\$ 319,000.00	\$ 311,200.00
19	Local Receipts: In Lieu of Tax	\$ 4.00	\$ -	\$ -
20	Local Receipts: Other	\$ 4,619,577.00	\$ 4,597,124.00	\$ 7,268,057.00
21	Transfers In of Surplus Fees	\$ 318,398.00	\$ 337,934.00	\$ 333,451.00
22	Transfers In Other Than Surplus Fees	\$ 479,968.00	\$ 70,357.00	\$ 78,918.00
23	Proprietary Function Funds (Only if Page 6 is Used)			\$ -
24	Total Resources Available (Lines 5 thru 23)	\$ 13,186,569.00	\$ 12,548,255.00	\$ 15,954,522.00
25	Total Disbursements & Transfers (Line 22, Pg 3, 4 & 5)	\$ 7,569,022.00	\$ 6,597,658.00	\$ 12,064,394.00
26	Balance Forward/Cash Reserve (Line 24 MINUS Line 25)	\$ 5,617,547.00	\$ 5,950,597.00	\$ 3,890,128.00
27	Cash Reserve Percentage			54%
PROPERTY TAX RECAP		Tax from Line 6		\$ 825,000.00
		County Treasurer Commission at 1%		\$ 8,250.00
		Total Property Tax Requirement		\$ 833,250.00

City of St. Paul in Howard County

To Assist the County For Levy Setting Purposes

The Cover Page identifies the Property Tax Request between Principal & Interest on Bonds and All Other Purposes. If your municipality needs more of a breakdown for levy setting purposes, complete the section below.

Property Tax Request by Fund:		<u>Property Tax Request</u>	
General Fund	\$	631,250.00	
Bond Fund	\$	202,000.00	
_____ Fund			
_____ Fund			
Total Tax Request	** \$	833,250.00	

** This Amount should agree to the Total Personal and Real Property Tax Required on the Cover Page 1.

Cash Reserve Funds

Statute 13-503 says cash reserve means funds required for the period before revenue would become available for expenditure but shall not include funds held in any special reserve fund. If the cash reserve on Page 2 exceeds 50%, you can list below funds being held in a special reserve fund.

<u>Special Reserve Fund Name</u>		<u>Amount</u>
Water/Sewer/Light Sinking	\$	128,000.00
Fire/Police/Ambulance Sinking	\$	115,000.00
General & Street Sinking	\$	117,000.00
Cemetary/Park/Pool/Library Sinking	\$	130,000.00
Total Special Reserve Funds	\$	490,000.00
Total Cash Reserve	\$	3,890,128.00
Remaining Cash Reserve	\$	3,400,128.00
Remaining Cash Reserve %		47%

Documentation of Transfers of Surplus Fees:

(Only complete if Transfers of Surplus Fees Were Budgeted)

Please explain where the monies will be transferred from, where the monies will be transferred to, and the reason for the transfer.

Transfer From:	Transfer To:
<u>Enterprise Funds</u>	<u>General Funds</u>
Amount: \$	333,451.00

Reason: For the support of General Funds

Transfer From:	Transfer To:
_____	_____
Amount: \$	

Reason:

Transfer From:	Transfer To:
_____	_____
Amount: \$	

Reason:

City of St. Paul in Howard County

Line No.	2019-2020 ADOPTED BUDGET Disbursements & Transfers	Operating Expenses (A)	Capital Improvements (B)	Other Capital Outlay (C)	Debt Service (D)	Other (E)	TOTAL
1	Governmental:						
2	General Government	\$ 439,556.00	\$ 547,700.00	\$ -	\$ 117,494.00	\$ -	\$ 1,104,750.00
3	Public Safety - Police and Fire	\$ 414,228.00	\$ 5,000.00	\$ 35,740.00	\$ -	\$ -	\$ 454,968.00
4	Public Safety - Other	\$ 50,850.00	\$ -	\$ 9,000.00	\$ -	\$ -	\$ 59,850.00
5	Public Works - Streets	\$ 393,265.00	\$ 2,009,580.00	\$ 34,000.00	\$ -	\$ 65,308.00	\$ 2,502,153.00
6	Public Works - Other	\$ 25,910.00	\$ 38,100.00	\$ 1,200.00	\$ -	\$ -	\$ 65,210.00
7	Public Health and Social Services	\$ -	\$ -	\$ -	\$ -	\$ -	\$ -
8	Culture and Recreation	\$ 334,246.00	\$ 15,610.00	\$ 12,500.00	\$ -	\$ -	\$ 362,356.00
9	Community Development	\$ 553,375.00	\$ 814,399.00	\$ -	\$ -	\$ 75,000.00	\$ 1,442,774.00
10	Miscellaneous	\$ 15,404.00	\$ 50,000.00	\$ -	\$ 1,542,022.00	\$ 13,610.00	\$ 1,621,036.00
11	Business-Type Activities:						
12	Airport						\$ -
13	Nursing Home						\$ -
14	Hospital						\$ -
15	Electric Utility	\$ 2,439,882.00	\$ 35,000.00	\$ 6,000.00	\$ -	\$ 224,017.00	\$ 2,704,899.00
16	Solid Waste	\$ 107,950.00	\$ -	\$ -	\$ -	\$ -	\$ 107,950.00
17	Transportation						\$ -
18	Wastewater	\$ 190,972.00	\$ 436,315.00	\$ 7,500.00	\$ 67,650.00	\$ 17,217.00	\$ 719,654.00
19	Water	\$ 368,292.00	\$ 289,560.00	\$ 50,000.00	\$ 193,725.00	\$ 17,217.00	\$ 918,794.00
20	Other						\$ -
21	Proprietary Function Funds (Page 6)					\$ -	\$ -
22	Total Disbursements & Transfers (Lns 2 thru 21)	\$ 5,333,930.00	\$ 4,241,264.00	\$ 155,940.00	\$ 1,920,891.00	\$ 412,369.00	\$ 12,064,394.00

(A) **Operating Expenses** should include Personal Services, Operating Expenses, Supplies and Materials, and Equipment Rental.

(B) **Capital Improvements** should include acquisition of real property or acquisition, construction, or extension of any improvements on real property.

(C) **Other Capital Outlay** should include other items to be inventoried (i.e. equipment, vehicles, etc.).

(D) **Debt Service** should include Bond Principal and Interest Payments, Payments to Retirement Interest-Free Loans from NDA (Airports) and other debt payments.

(E) **Other** should include Judgments, Transfers, Transfers of Surplus Fees, and Proprietary Function Funds if a separate budget is filed.

City of St. Paul in Howard County

Line No.	2018-2019 ACTUAL/ESTIMATED Disbursements & Transfers	Operating Expenses (A)	Capital Improvements (B)	Other Capital Outlay (C)	Debt Service (D)	Other (E)	TOTAL
1	Governmental:						
2	General Government	\$ 406,067.00	\$ 9,000.00	\$ 41,454.00	\$ 78,528.00	\$ -	\$ 535,049.00
3	Public Safety - Police and Fire	\$ 379,128.00	\$ 5,000.00	\$ 59,929.00	\$ -	\$ -	\$ 444,057.00
4	Public Safety - Other	\$ 45,685.00	\$ -	\$ 9,000.00	\$ -	\$ -	\$ 54,685.00
5	Public Works - Streets	\$ 322,824.00	\$ 24,500.00	\$ 34,600.00	\$ -	\$ 70,357.00	\$ 452,281.00
6	Public Works - Other	\$ 27,100.00	\$ 1,815.00	\$ 3,000.00	\$ -	\$ -	\$ 31,915.00
7	Public Health and Social Services	\$ -	\$ -	\$ -	\$ -	\$ -	\$ -
8	Culture and Recreation	\$ 297,371.00	\$ 367.00	\$ 20,860.00	\$ -	\$ -	\$ 318,598.00
9	Community Development	\$ 488,120.00	\$ 400,000.00	\$ -	\$ -	\$ 46,087.00	\$ 934,207.00
10	Miscellaneous	\$ 15,937.00	\$ 27,540.00	\$ -	\$ 202,853.00	\$ -	\$ 246,330.00
11	Business-Type Activities:						
12	Airport						\$ -
13	Nursing Home						\$ -
14	Hospital						\$ -
15	Electric Utility	\$ 2,385,921.00	\$ 34,000.00	\$ 6,000.00	\$ -	\$ 235,149.00	\$ 2,661,070.00
16	Solid Waste	\$ 103,373.00	\$ -	\$ -	\$ -	\$ -	\$ 103,373.00
17	Transportation						\$ -
18	Wastewater	\$ 171,800.00	\$ 40,000.00	\$ 7,500.00	\$ 63,459.00	\$ 28,349.00	\$ 311,108.00
19	Water	\$ 314,380.00	\$ 18,722.00	\$ 46,784.00	\$ 96,750.00	\$ 28,349.00	\$ 504,985.00
20	Other						\$ -
21	Proprietary Function Funds						\$ -
22	Total Disbursements & Transfers (Ln 2 thru 21)	\$ 4,957,706.00	\$ 560,944.00	\$ 229,127.00	\$ 441,590.00	\$ 408,291.00	\$ 6,597,658.00

- (A) **Operating Expenses** should include Personal Services, Operating Expenses, Supplies and Materials, and Equipment Rental.
- (B) **Capital Improvements** should include acquisition of real property or acquisition, construction, or extension of any improvements on real property.
- (C) **Other Capital Outlay** should include other items to be inventoried (i.e. equipment, vehicles, etc.).
- (D) **Debt Service** should include Bond Principal and Interest Payments, Payments to Retirement Interest-Free Loans from NDA (Airports) and other debt payments.
- (E) **Other** should include Judgments, Transfers, Transfers of Surplus Fees, and Proprietary Function Funds if a separate budget is filed.

City of St. Paul in Howard County

Line No.	2017-2018 ACTUAL Disbursements & Transfers	Operating Expenses (A)	Capital Improvements (B)	Other Capital Outlay (C)	Debt Service (D)	Other (E)	TOTAL
1	Governmental:						
2	General Government	\$ 337,900.00				\$ 6,325.00	\$ 344,225.00
3	Public Safety - Police and Fire	\$ 373,312.00		\$ 21,599.00		\$ 10,800.00	\$ 405,711.00
4	Public Safety - Other	\$ 40,549.00					\$ 40,549.00
5	Public Works - Streets	\$ 370,515.00	\$ 278,106.00			\$ 296,079.00	\$ 944,700.00
6	Public Works - Other						\$ -
7	Public Health and Social Services	\$ 49,879.00					\$ 49,879.00
8	Culture and Recreation	\$ 298,028.00				\$ 2,400.00	\$ 300,428.00
9	Community Development	\$ 304,302.00	\$ 169,799.00			\$ 201,655.00	\$ 675,756.00
10	Miscellaneous				\$ 614,830.00	\$ 2,908.00	\$ 617,738.00
11	Business-Type Activities:						
12	Airport						\$ -
13	Nursing Home						\$ -
14	Hospital						\$ -
15	Electric Utility	\$ 2,350,525.00				\$ 263,131.00	\$ 2,613,656.00
16	Solid Waste	\$ 112,483.00				\$ 12,804.00	\$ 125,287.00
17	Transportation						\$ -
18	Wastewater	\$ 144,991.00			\$ 121,334.00	\$ 20,932.00	\$ 287,257.00
19	Water	\$ 307,876.00	\$ 28,383.00		\$ 806,046.00	\$ 21,531.00	\$ 1,163,836.00
20	Other						\$ -
21	Proprietary Function Funds						\$ -
22	Total Disbursements & Transfers (Ln 2 thru 21)	\$ 4,690,360.00	\$ 476,288.00	\$ 21,599.00	\$ 1,542,210.00	\$ 838,565.00	\$ 7,569,022.00

- (A) **Operating Expenses** should include Personal Services, Operating Expenses, Supplies and Materials, and Equipment Rental.
- (B) **Capital Improvements** should include acquisition of real property or acquisition, construction, or extension of any improvements on real property.
- (C) **Other Capital Outlay** should include other items to be inventoried (i.e. equipment, vehicles, etc.).
- (D) **Debt Service** should include Bond Principal and Interest Payments, Payments to Retirement Interest-Free Loans from NDA (Airports) and other debt payments.
- (E) **Other** should include Judgments, Transfers, Transfers of Surplus Fees, and Proprietary Function Funds if a separate budget is filed.

CORRESPONDENCE INFORMATION

ENTITY OFFICIAL ADDRESS

If no official address, please provide address where correspondence should be sent

NAME	City of St. Paul
ADDRESS	704 6th Street
CITY & ZIP CODE	St. Paul, 68873
TELEPHONE	(308) 754-4483
WEBSITE	

	BOARD CHAIRPERSON	CLERK/TREASURER/SUPERINTENDENT/OTHER	PREPARER
NAME	Joel Bergman	Connie Jo Beck	Gary Hinrichs
TITLE /FIRM NAME	Mayor	Clerk	CPA/Dana F. Cole & Company, LLP
TELEPHONE	(308) 754-4483	(308) 754-4483	(308) 728-3014
EMAIL ADDRESS		cjbeck@cityofstpaulne.org	hinrichs@danacole.com

For Questions on this form, who should we contact (please one): Contact will be via email if supplied.

- Board Chairperson
- Clerk / Treasurer / Superintendent / Other
- Preparer

City of St. Paul in Howard County

2019-2020 LID SUPPORTING SCHEDULE

Calculation of Restricted Funds

Total Personal and Real Property Tax Requirements	(1)	\$	833,250.00
Motor Vehicle Pro-Rate	(2)	\$	1,000.00
In-Lieu of Tax Payments	(3)	\$	-
Prior Year Budgeted Capital Improvements that were excluded from Restricted Funds.			
Prior Year Capital Improvements Excluded from Restricted Funds (From Prior Year Lid Support, Line (17))		\$	500,000.00
LESS: Amount Spent During 2018-2019	(4)	\$	500,000.00
LESS: Amount Expected to be Spent in Future Budget Years	(5)	\$	-
Amount to be included as Restricted Funds (<i>Cannot Be A Negative Number</i>)	(6)	\$	-
Motor Vehicle Tax	(7)	\$	42,000.00
Local Option Sales Tax	(8)	\$	311,200.00
Transfers of Surplus Fees	(9)	\$	333,451.00
Highway Allocation and Incentives	(10)	\$	322,245.00
MIRF	(11)	\$	-
Motor Vehicle Fee	(12)	\$	20,000.00
Municipal Equalization Fund	(13)	\$	102,054.00
Insurance Premium Tax	(14)	\$	-
Nameplate Capacity Tax	(15a)	\$	-
TOTAL RESTRICTED FUNDS (A)	(16)	\$	1,965,200.00

Lid Exceptions

Capital Improvements (Real Property and Improvements on Real Property)		\$	500,000.00	(17)
LESS: Amount of prior year capital improvements that were excluded from previous lid calculations but were not spent and now budgeted this fiscal year (<i>cannot exclude same capital improvements from more than one lid calculation.</i>)				
Agrees to Line (6).		\$	-	(18)
Allowable Capital Improvements	(19)	\$	500,000.00	
Bonded Indebtedness	(20)	\$	202,000.00	
Public Facilities Construction Projects (Statutes 72-2301 to 72-2308)	(21)			
Interlocal Agreements/Joint Public Agency Agreements	(22)	\$	294,422.00	
Public Safety Communication Project (Statute 86-416)	(23)			
Payments to Retire Interest-Free Loans from the Department of Aeronautics (Public Airports Only)	(24)			
Judgments	(25)			

LID COMPUTATION FORM

City of St. Paul
IN
Howard County

COMPUTATION OF LIMIT FOR FISCAL YEAR 2019-2020

PRIOR YEAR RESTRICTED FUNDS AUTHORITY OPTION 1 OR OPTION 2

OPTION 1

2018-2019 Restricted Funds Authority (Base Amount) = Line (8) from last year's Lid Form 1,606,147.43
Option 1 - (1)

OPTION 2 - *Only use if a vote was taken at a townhall meeting to exceed Lid for one year*

Line (1) of Prior Year Lid Computation Form Option 2 - (A)

Allowable Percent Increase **Less** Vote Taken %
 (From Prior Year Lid Computation Form Line (6) - Line (5)) Option 2 - (B)

Dollar Amount of Allowable Increase Excluding the vote taken -
 Line (A) X Line (B) Option 2 - (C)

Calculated 2018-2019 Restricted Funds Authority (Base Amount) = Option 2 - (1)
 Line (A) **Plus** Line (C)

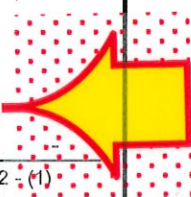

ALLOWABLE INCREASES

- 1 **BASE LIMITATION PERCENT INCREASE (2.5%)** 2.50 %
(2)

- 2 **ALLOWABLE GROWTH PER THE ASSESSOR MINUS 2.5%** - %
(3)

$$\frac{1,135,127.00}{2019 \text{ Growth per Assessor}} \div \frac{126,335,765.00}{2018 \text{ Valuation}} = \frac{0.90}{\text{Multiply times 100 To get \%}} \%$$

- 3 **ADDITIONAL ONE PERCENT COUNCIL/BOARD APPROVED INCREASE** 1.00 %
(4)

$$\frac{4}{4} = 100.00 \%$$

LID COMPUTATION FORM

City of St. Paul
IN
Howard County

TOTAL ALLOWABLE PERCENT INCREASE = Line (2) + Line (3) + Line (4) + Line (5)	<u>3.50</u> %
	(6)
Allowable Dollar Amount of Increase to Restricted Funds = Line (1) x Line (6)	<u>56,215.16</u>
	(7)
Total Restricted Funds Authority = Line (1) + Line (7)	<u>1,662,362.59</u>
	(8)
Less: Restricted Funds from Lid Supporting Schedule	<u>968,778.00</u>
	(9)
Total Unused Restricted Funds Authority = Line (8) - Line (9)	<u>693,584.59</u>
	(10)

**LINE (10) MUST BE GREATER THAN OR EQUAL TO ZERO OR
YOU ARE IN VIOLATION OF THE LID LAW.**

**THE AMOUNT OF UNUSED RESTRICTED FUNDS AUTHORITY ON LINE (10)
MUST BE PUBLISHED IN THE NOTICE OF BUDGET HEARING.**

Municipality Levy Limit Form
City of St. Paul in Howard County

Political Subdivision	Personal and Real Property Tax Request <i>(Column A)</i>	Judgments (Not Paid by Liability Insurance) <i>(Column B)</i>	Pre-Existing Lease - Purchase Contracts-7/98 <i>(Column C)</i>	* Bonded Indebtedness <i>(Column D)</i>	Interest Free Financing (Public Airports) <i>(Column E)</i>	Tax Request Subject to Levy Limit <i>(Column F)</i> [(Column A) MINUS (Columns B, C, D, E)]	Valuation <i>(Column G)</i>	Calculated Levy <i>(Column H)</i> [(Column F) DIVIDED BY (Column G) MULTIPLIED BY 100]
City/Village -	833,250.00			202,000.00		631,250.00	127,104,101	0.496640

Others subject to allocation-

						-		-
						-		-
						-		-
						-		-

Off-Street Parking District						-		
-----------------------------	--	--	--	--	--	---	--	--

Calculated Levy for Off-Street Parking District = (Column F) DIVIDED BY (Column G) MULTIPLIED BY 100 MULTIPLIED BY (Column G) DIVIDED BY (Column G {City/Village Line})

-

NOTE:

Municipality Levy Limit is 45 cents plus 5 cents for interlocal agreements. (77-3442)

Total Calculated Levy can ONLY be greater than 45 cents if there is Interlocal Agreements.

The Calculated Levy for Interlocal Agreements should be the maximum of **5 cents OR LESS**.

Others subject to allocation may include airport authorities, community redevelopment authorities, off-street parking districts, and transit authorities.

Total Calculated Levy
[Total of (Column H)]

0.496640

(Box 1)

Tax Request to Support Interlocal Agreements

63,552.05

(Box 2)

Calculated Levy for Interlocal Agreements
[(Box 2) DIVIDED BY (Column G (City/Village Line)) MULTIPLIED BY 100]

0.050000

(Box 3)
5 Cents or LESS

Calculated Levy For Levy Limit Compliance
[(Box 1) MINUS (Box 3)]

0.446640

(Box 4)

* Tax Request to Support Public Safety Communication Projects

--

(Box 5)

* Tax Request to Support Public Facilities Construction Projects

--

(Box 6)

* State Statute Section 86-416 allows for a special tax to fund public safety communication projects. The tax has the same status as bonded indebtedness. State Statute 72-2301 through 72-2308 allows bonds to be issued for Public Facilities Construction Projects. Amounts should be included in Bonded Indebtedness above. Please indicate the amount specifically used for the communication project in Box 5 and the Construction Projects in Box 6. Board minutes documenting the approval of the taxes must be included.

City of St. Paul in Howard County

2019-2020 CAPITAL IMPROVEMENT LID EXEMPTIONS

Description of Capital Improvement	Amount Budgeted
Middle Loup Subdivision	\$ 500,000.00

City of St. Paul
IN
Howard County, Nebraska

NOTICE OF BUDGET HEARING AND BUDGET SUMMARY

PUBLIC NOTICE is hereby given, in compliance with the provisions of State Statute Sections 13-501 to 13-513, that the governing body will meet on the 3rd day of September 2019, at 7:00 o'clock P.M., at City Office for the purpose of hearing support, opposition, criticism, suggestions or observations of taxpayers relating to the following proposed budget. The budget detail is available at the office of the Clerk during regular business hours.

2017-2018 Actual Disbursements & Transfers	\$ 7,569,022.00
2018-2019 Actual/Estimated Disbursements & Transfers	\$ 6,597,658.00
2019-2020 Proposed Budget of Disbursements & Transfers	\$ 12,064,394.00
2019-2020 Necessary Cash Reserve	\$ 3,890,128.00
2019-2020 Total Resources Available	\$ 15,954,522.00
Total 2019-2020 Personal & Real Property Tax Requirement	\$ 833,250.00
Unused Budget Authority Created For Next Year	\$ 693,584.59

Breakdown of Property Tax:

Personal and Real Property Tax Required for Non-Bond Purposes	\$ 631,250.00
Personal and Real Property Tax Required for Bonds	\$ 202,000.00

NOTICE OF SPECIAL HEARING TO SET FINAL TAX REQUEST

PUBLIC NOTICE is hereby given, in compliance with the provisions of State Statute Section 77-1601.02, that the governing body will meet on the 3rd day of September 2019, at 7:00 o'clock P.M., at City Office for the purpose of hearing support, opposition, criticism, suggestions or observations of taxpayers relating to setting the final tax request at a different amount than the prior year tax request.

	2018	2019	Change
Operating Budget	11,832,805.00	12,064,394.00	2%
Property Tax Request	\$ 853,879.25	\$ 833,250.00	-2%
Valuation	126,335,765	127,104,101	1%
Tax Rate	0.675881	0.655565	-3%
Tax Rate if Prior Tax Request was at Current Valuation	0.671795		

Checklist of Items to Be Completed and Submitted

Page 1 (Cover Page):

- Total Personal and Real Property Tax Required agrees to the amount on the bottom of Page 2, Total Property Tax Requirement.
- Outstanding Bonded Indebtedness Section was completed. *(If Applicable)*
- Total Certified Valuation was completed.
- Joint Public Agency & Interlocal Agreements is indicated by checking the box.
- Report of Trade Names, Corporate Names, and Business Names is indicated by checking the box.

Page 2 (Budget Form):

- Column 1, Line 5 agrees to last year's budget form Column 1, Line 26. If not, provide explanation.
- Column 1, Line 26 agrees to Column 2, Line 5.
- Column 2, Line 26 agrees to Column 3, Line 5.
- Column 3, Line 26 is equal or greater than zero. Cannot budget to have a negative fund balance.
- Motor Vehicle Tax and Fee have been budgeted.
- Municipal Equalization Aid and Highway Allocation are reasonable compared to projections.
- Cash reserve is less than 50% or is explained on page 2-A

Page 2-A (Transfer Page, *If Applicable*):

- Transfers noted on Page 2, Column 2 are explained.

Page 7 (Correspondence Page):

- Correspondence Information is completed, indicating Contact For Correspondence.

Page 8 (Lid Supporting Schedule):

- Total Personal and Real Property Tax Requirements Line (1) agrees to amount on bottom of Page 2, Total Property Tax Requirement.
- Other Restricted Funds agree to amounts in Column 3, Page 2.
- Capital Improvement Lid Exceptions Line (4) agrees to last year's budget Page 8, Line (17).
- Line (6) agrees to Line (18).
- Line (5) cannot be greater than Page 4, Column B, Line (22).
- Line (17) cannot be greater than Page 3, Column B, Line (22)
- Line (17) must be greater than or equal to Line (18).

Page 9 & 10 (Lid Computation Form):

- Line (1) agrees to last year's budget Page 10, Line (8).
- Line (10) is greater than or equal to zero.

Page 11 (Levy Limit Form):

- Total Personal and Real Property Tax Request (Column A, Line 1) agrees to amount on bottom of Page 2, Total Property Tax Requirement.
- Valuation (Column G, Line 1) agrees to Total Certified Valuation on Cover Page (Page 1).

Page 12 (Capital Improvements):

- Total agrees to Page 8 Line (17)

Step by Step Information

Basic Data Input

- 1 Fill in each box, this will allow information to flow throughout the documents

Actual & Budgeted Figures - Page 2-5

- 2 Complete first column based on actual numbers for prior fiscal years. Estimate figures in column 2 to the best of your ability and past experience. The ending balance should represent all the Subdivisions assets, including money held at the County Treasurer. See below for Function Definitions and Classifications.
- 3 Complete column 3 with budget numbers for upcoming fiscal year.

Proprietary Funds Page 6

- 4 Complete these pages if you have a proprietary function that files a separate budget with the Clerk

Lid Computation Page 9-10

- 5 Complete Option 1 or 2 based on the prior year budget form.
- 6 Fill in allowable increases. All subdivisions are allowed a 2.5% increase.
- 7 Review Line 10, if negative, consider if all allowable increases were added or consider lid exemptions on Lid Supporting Schedule -Page 8

Lid Support Page 8

- 8 Complete Lid Exemptions if needed. Subdivision must show a zero or positive number on Lid Computation Page 9-10 in order to be in compliance with Lid. If Capital improvement exemptions are noted, complete Page 12

Levy Limit Page 11

- 9 Verify the Municipality is projecting a levy within the levy limit established by statute

Cover - Page 1

- 10 If the Subdivision was a member of an interlocal agreement, place an "X" in the appropriate box.
- 11 If the Subdivision operated a function under a separate trade name or business name, place an "X" in the appropriate box.
- 12 If you want a separate bond levy, you need to put the amount of taxes you are requesting for the bonds in cell B13 "Principal and Interest on Bonds"

Page 2-A

- 13 If you want the general levy separated into a levy for a special purpose, include a breakdown of the separate levy requested. Be sure to contact the County Clerk, some counties have limited space requirements and only allow subdivisions to have a maximum of two levies (General and Bond).
- 14 If you showed transfers of surplus fees in Column 3 on Page 2, you need to include information about the transfers.

Page 7

- 15 Complete all correspondence information

Interlocal Agreement and Trade Name Reports

- 16 Complete the Interlocal Agreement and Trade Name reports. There is a \$20 day fine for not filing these reports by September 20th.

Checklist

- 17 Review items listed on the Checklist sheet to eliminate errors

Publish and Hold Hearings

- 18 Need to publish information about hearings 4 days prior to date of hearings in a newspaper of general circulation in the subdivision
- 19 Hold Hearings and Board needs to adopt budget and tax request or make changes to budget and then adopt budget.
You are allowed to post the hearing notice if you are budgeting to expend less than \$10,000. If you posted hearing notice, provide details regarding where it was posted
- 20 If Board adopts budget different than what was published, they must republish the changes and the reason for the change within 20 days after adopting the budget.

Filing and Attachments

- 21 File budget and attachments with State Auditor either electronically or by mail
- 22 File budget and attachments with County Clerk.
- 23 Attachments:
 - Certification of Valuation(s). (From County Assessor)
 - Board minutes approving Budget.
 - Publisher's Affidavit of Publication for the Notice of Budget Hearing. If you were allowed to post your notice, include details of where it was posted.
 - Board minutes showing at least 75% Board approval for additional 1% increase in the Restricted Funds Subject to Limitation. *(If Applicable)*
 - Special election Sample Ballot and Election Results or townhall meeting Record of Action. *(If Applicable)*
 - Interlocal Agreement and Trade Name Reports
 - Resolution authorizing bonds for Public Facilities Construction Projects. *(If Applicable)*

Overall Information

The Cell Is Locked:

UNDER NO CIRCUMSTANCES WILL PASSWORDS BE GIVEN OUT. Either the cell is locked because it contains a formula or verbiage that needs to remain consistent on every budget

Please Complete this **Basic Data Input Area** -It will put inform.

		INPUT ↓
Name of <i>City or Village</i>		City of St. Paul
Name of County in which Subdivision resides:		Howard
First Date of Fiscal Year:		October 1, 2019
Last Date of Fiscal Year:		September 30, 2020
Current Valuation		127,104,101
Prior Year Valuation		126,335,765
Prior Year Property Tax Request		853,879.25
Prior Year Operating Budget Amount		11,832,805.00
Prior Year Tax Levy Rate		0.675881
Outstanding Bond Principal on Last Day of Fiscal Year		3,555,000.00
Outstanding Bond Interest on Last Day of Fiscal Year		463,474.00
Prior Year Capital Improvement Exemption		500,000.00
Amount spent on Capital Improvements during last year		500,000.00
Amount still expected to be spent on Capital Improvements.		
Budget Hearing Held On:	Month	September
	Day of month	3rd
	Year	2019
	Time	7:00
	A.M. or P.M.	P.M.
	Location	City Office
Final Tax Request Hearing Held On:	Month	September

Day of month	3rd
Year	2019
Time	7:00
A.M. or P.M.	P.M.
Location	City Office

**CITY OF ST. PAUL
Budget 2019 - 2020**

S:\Budget 2019-2020\Dana F Cole 19-20 Budget 8-14-19.xlsx\GENERAL

CODES						
	Est Total 2018 - 2019				Budgeted Total 2019-2020	
100	845,425	10	406,067	100	825,000	10
101	300,500	11	379,128	101	700,000	11
102	1,000	12	45,685	102	1,000	12
103		13	322,824	103		13
104	314,916	14	27,100	104	322,245	14
105	20,000	15		105	20,000	15
106		16	297,371	106		16
107	82,452	17	488,120	107	102,054	17
108		18	15,937	108		18
109	42,000	20	9,000	109	42,000	20
110	319,000	21	5,000	110	311,200	21
111		22		111		22
112	4,597,124	23	24,500	112	7,268,057	23
113	337,934	24	1,815	113	333,451	24
114	70,357	25		114	78,918	25
115		26	367	115		26
999		27	400,000	999		27
998		28	27,540	998		28
	<u>6,930,708.00</u>	30	41,454		<u>10,003,925</u>	30
		31	59,929			31
		32	9,000			32
		33	34,600			33
		34	3,000			34
		35				35
		36	20,860			36
		37				37
		38				38
		40	78,528			40
		41				41
		42				42
		43				43
		44				44
		45				45
		46				46
		47				47
		48	202,853			48
		50				50
		51				51
		52				52
		53	70,357			53
		54				54

**City of St. Paul
Total Property Tax Request**

	2018-2019	2019-2020
General	\$ 140,425	\$ 140,000
Street	\$ -	\$ -
Fire	\$ 29,000	\$ 29,000
Police	\$ 238,000	\$ 238,000
Cemetary	\$ 19,000	\$ 19,000
Pool	\$ 52,000	\$ 52,000
Park	\$ 55,000	\$ 55,000
Recreation	\$ -	\$ -
Library	\$ 76,000	\$ 76,000
Senior Center	\$ 8,000	\$ 8,000
Civic Center	\$ 8,000	\$ 8,000
	<u>\$ 625,425</u>	<u>\$ 625,000</u>
Bond Fund	\$ 220,000	\$ 200,000
	<u>\$ 845,425</u>	<u>\$ 825,000</u>

**City of St. Paul
Budget Comparison Schedule**

	<i>General</i>	<i>% Increase (Decrease)</i>	<i>Debt Service</i>	<i>% Increase (Decrease)</i>	<i>Total</i>	<i>% Increase (Decrease)</i>
Request for property taxes						
2018-2019	620,906		295,930		916,836	
2019-2020	<u>631,250</u>	<u>1.67%</u>	<u>202,000</u>	<u>-31.74%</u>	<u>833,250</u>	<u>-9.12%</u>
Increase (decrease)	<u>10,344</u>		<u>(93,930)</u>		<u>(83,586)</u>	

Valuation						
2018-2019	124,181,080		124,181,080		124,181,080	
2019-2020	<u>127,104,101</u>	<u>2.35%</u>	<u>127,104,101</u>	<u>2.35%</u>	<u>127,104,101</u>	<u>2.35%</u>
Increase (decrease)	<u>2,923,021</u>		<u>2,923,021</u>		<u>2,923,021</u>	

Levy						
2018-2019	0.500000		0.238305		0.738306	
2019-2020	<u>0.496640</u>	<u>-0.67%</u>	<u>0.158925</u>	<u>-33.31%</u>	<u>0.655565</u>	<u>-11.21%</u>
Increase (decrease)	<u>(0.003360)</u>		<u>(0.079380)</u>		<u>(0.082741)</u>	

Example

	<u>Average Assessed Value</u>	<u>Levy Rate</u>	<u>Assessed Taxes</u>	
2018-2019	100,000	0.738306	\$ 738.31	
2019-2020 w/above increase	102,354	0.655565	\$ 671.00	Estimated
Increase (decrease)			<u>\$ (67.31)</u>	

Tax Request Tax Levy

**City of St. Paul
Prior Budget Amount Comparisons**

		Year Ended 9/30/2013	Year Ended 9/30/2014	Year Ended 9/30/2015	Year Ended 9/30/2016	Year Ended 9/30/2017	Year Ended 9/30/2018	(Estimated) Year Ended 9/30/2018	(Budgeted) Year Ended 9/30/2019
<u>Cash & Investments</u>	Bond Fund	203,194	223,719	243,511	177,255	218,781	159,562	218,717	(1,105,214)
	All Other Governmental	1,891,839	2,067,985	2,344,693	2,447,289	2,576,939	2,605,532	2,501,259	1,584,640
	Proprietary	1,967,572	2,229,487	2,694,025	2,658,943	3,248,668	2,852,453	3,230,621	3,410,702
Total		4,062,605	4,521,191	5,282,229	5,283,487	6,044,388	5,617,547	5,950,597	3,890,128
<u>Tax Request</u>	General	492,186	508,498	525,751	535,838	554,939	554,939	620,906	631,250
	Bond	225,942	253,086	252,061	251,073	277,470	277,470	295,930	202,000
Total		718,128	761,584	777,812	786,911	832,409	832,409	916,836	833,250
<u>Levy</u>	General	0.500	0.500	0.500	0.500	0.500	0.500	0.500	0.497
	Bond	0.230	0.249	0.240	0.240	0.250	0.250	0.238	0.159
Total		0.730	0.749	0.740	0.740	0.750	0.750	0.738	0.656
Total Debt (Bonds & Loans)		5,212,066	4,780,048	4,758,263	4,236,047	5,285,000	3,860,000	3,555,000	5,859,891

City of St. Paul
Schedule of Transfers

	2018/2019 Estimated		2019/2020 Estimated	
	Transfers In	Transfers Out	Transfers In	Transfers Out
General Fund				
General	113,396		98,868	LT 17217, WT 17217, SW 17217, ST 17217, Tractor 30,000
Police	140,000		140,000	Lts
Fire	-		-	
Ambulance				
Cemetery				
Pool	-		13,610	Keno: deck, heater, Chair platform
Park	66,800	-	66,800	Lts
Recreation	-		-	
Library	-		-	
Senior Center	-		-	
Special Revenue Funds				
Street	-	70,357	-	Gen 17217, ST 30,0 VP-18091
Grant				
Sales Tax		46,087		75,000 for Civic loan
Keno		-		13,610 Pool: heater, deck, platform
TIFF		-		
Civic Center	46,087		75,000	Sales Tax - Civic loan
Enterprise Funds				
Light		235,149	224,017	Gen 17217, Pd 140 PK-66800
Water		28,349	17,217	Gen US Wage
Sewer		28,349	17,217	Gen US Wage
Landfill				
Bond Fund	42,008		18,091	St- Assessments
Grand Total	408,291	408,291	412,369	412,369

dh

City of St. Paul
Schedule of Transfers

	2018/2019		2019/2020	
	Estimated		Estimated	
	Transfers In	Transfers Out	Transfers In	Transfers Out
General Fund				
General	113,396		98,868	
Police	140,000		140,000	
Fire	-		-	
Ambulance				
Cemetary				
Pool	-		13,610	
Park	66,800	-	66,800	-
Recreation	-		-	
Library	-		-	
Senior Center	-		-	
Special Revenue Funds				
Street	-	70,357	-	65,308
Grant				
Sales Tax		46,087		75,000
Keno		-		13,610
TIFF		-		-
Civic Center	46,087		75,000	
Enterprise Funds				
Light		235,149		224,017
Water		28,349		17,217
Sewer	-	28,349	-	17,217
Landfill				-
Bond Fund	42,008		18,091	
Grand Total	<u>408,291</u>	<u>408,291</u>	<u>412,369</u>	<u>412,369</u>

**City of St. Paul
Schedule of Debt Payments**

	Balance 10/1/2018	Principal Payment	Interest Payment	New Debt	Balance 9/30/2019	Principal Payment	Interest Payment	New Debt	Balance 9/30/2020
Bond Fund									
GO Refunding Bonds (2015) (80% Pool/20% Street)	320,000	(105,000)	(4,159)		215,000	(110,000)	(3,005)		105,000
Street Anticipation Bonds (2019)					-			2,067,322	2,067,322
Street - Bonds (2016)	46,900	(11,200)	(624)		35,700	(11,200)	(501)		24,500
Street - GO Bonds (2017)	800,000	(50,000)	(19,162)		750,000	(50,000)	(18,525)		700,000
Street - GO Bonds (2016)	413,400	-	(3,535)		413,400	(32,500)	(7,223)		380,900
Street - GO Bonds (2017)	74,400	(7,750)	(1,423)		66,650	(7,750)	(1,318)		58,900
	1,654,700	(173,950)	(28,903)	-	1,480,750	(211,450)	(30,572)	2,067,322	3,336,622
Enterprise Fund									
Water Bonds (2016)	1,120,950		(10,134)		1,120,950	(88,125)	(19,584)		1,032,825
Water Bonds (2012)					-				-
Water - Bonds (Refunding 2013)					-				-
Water - Bonds (2019)					-			273,145	273,145
Water Anticipation Bonds (2016)					-				-
Water - Bonds (2016)	144,050	(34,400)	(1,917)		109,650	(34,400)	(1,538)		75,250
Water - DEQ Bond Refinance	425,000	(30,000)	(9,615)		395,000	(30,000)	(9,255)		365,000
Water - GO Bonds (2017)	88,800	(9,250)	(1,698)		79,550	(9,250)	(1,573)		70,300
Sewer - Bonds (2019)					-			399,424	399,424
Sewer - Bonds Refunding (2017)	150,000	(15,000)	(2,157)		135,000	(15,000)	(2,005)		120,000
Sewer - Bonds (2012)					-				-
Sewer - Bonds (2016)	55,650		(517)		55,650	(4,375)	(972)		51,275
Sewer Anticipation Bonds (2016)					-				-
Sewer - Bonds (2016)	144,050	(34,400)	(1,917)		109,650	(34,400)	(1,538)		75,250
Sewer - GO Bonds (2017)	76,800	(8,000)	(1,468)		68,800	(8,000)	(1,360)		60,800
	2,205,300	(131,050)	(29,423)	-	2,074,250	(223,550)	(37,825)	672,569	2,523,269
Grand Total	3,860,000	(305,000)	(58,326)	-	3,555,000	(435,000)	(68,397)	2,739,891	5,859,891

**City of St. Paul
Cash Summary**

	Cash 10/1/2018 Balance	Estimated 2018/2019 Revenues	Estimated 2018/2019 Expenditures	Estimated Cash Balance 9/30/2019	Estimated 2019/2020 Revenues	Estimated 2019/2020 Expenditures	Estimated Cash Balance 9/30/2020
General Fund							
General		390,286	(398,169)		792,022	(923,756)	
Police		384,376	(401,814)		382,275	(404,294)	
Fire		52,492	(42,243)		51,000	(50,674)	
Ambulance		58,392	(54,685)		63,225	(59,850)	
Cemetary		36,129	(31,915)		65,260	(65,210)	
Pool		89,357	(84,540)		102,910	(102,491)	
Park		129,472	(121,337)		124,850	(127,982)	
Recreation		11,666	(10,386)		22,000	(22,000)	
Library		107,094	(102,335)		110,560	(109,883)	
Senior Center		8,080	(6,500)		8,020	(7,980)	
Civic Center		110,658	(115,939)		135,615	(135,520)	
	-	-	-	-	-	-	-
	1,475,000	1,378,002	(1,369,863)	1,483,139	1,857,737	(2,009,640)	1,331,236
Special Revenue Funds							
Street	(585)	469,177	(452,281)	16,311	2,511,658	(2,502,153)	25,816
TIFF	(6,667)	23,872	(14,441)	2,764	37,482	(37,494)	2,752
Program Income	102	588	(687)	3	154	(154)	3
Keno	127,488	53,000	(42,790)	137,698	47,225	(78,860)	106,063
Sales Tax/Econ. Develop.	891,424	785,357	(934,207)	742,574	700,200	(1,442,774)	-
	1,011,762	1,331,994	(1,444,406)	899,350	3,296,719	(4,061,435)	134,634
Enterprise Funds							
Light	1,735,638	2,846,755	(2,661,070)	1,921,323	2,867,883	(2,704,899)	2,084,307
Water	96,559	666,561	(504,985)	258,135	922,648	(918,794)	261,989
Sewer	921,406	324,936	(311,108)	935,234	720,447	(719,654)	936,027
Landfill	98,850	120,452	(103,373)	115,929	120,400	(107,950)	128,379
	2,852,453	3,958,704	(3,580,536)	3,230,621	4,631,378	(4,451,297)	3,410,702
Bond Fund	159,562	262,008	(202,853)	218,717	218,091	(1,542,022)	(1,105,214)
Internal Service Fund	118,770	-	-	118,770	-	-	118,770
Grand Total	5,617,547	6,930,708	(6,597,658)	5,950,597	10,003,925	(12,064,394)	3,890,128

RECOMMENDATION OF THE NEBRASKA LIQUOR CONTROL COMMISSION

Date delivered from NLCC office: **July 30, 2019 Tracy**

I, Connie Jo Beck Clerk of the City of St. Paul, NE
(City, Village or County)

Nebraska, hereby report to the Nebraska Liquor Control Commission in accordance with Revised Statutes of Nebraska, Chapter 53, Section 134 (7) the recommendation of said city, village or county, as the case may be relative to the application for a license under the provisions of the Nebraska Liquor Control Act as applied for by:

La Pena Authentic Food LLC dba La Pena Authentic Food
515 Howard Avenue, Saint Paul, Nebraska (Howard County)
NEW APPLICATION for Class I-123018
45 days – 08/28/2019

1. Notice of local hearing was published in a legal newspaper in or of general circulation in city, village or county, one time not less than 7 and not more than 14 days before time of hearing.

Check one: Yes XXX No _____

The Statutes require that such hearing shall be held not more than 45 days after the date of receipt of this notice from the Commission.

2. Local hearing was held not more that 45 days after receipt of notice from the Nebraska Liquor Control Commission.

Check one: Yes XXX No _____

3. Date of hearing of Governing Body: Monday, August 19, 2019 at 7:00 p.m.

4. Type or write the Motion as voted upon by the Governing Body. If additional Motions are made by the Governing Body, then use an additional page and follow same format.

5. Motion was made by: _____ Seconded by: _____

6. Roll Call Vote: _____

7. Check one: Motion Passed: _____ Motion Failed: _____

8. If the motion is for recommendation of denial of the applicant, then list the reasons of the governing body upon which the motion was made.

(Attached additional page(s) if necessary)

SIGN HERE _____ **DATE** August 19, 2019
(Clerks Signature)
City Clerk/Deputy Treasurer

Certificate of Publication

STATE OF NEBRASKA, } ss. \$ 6.22
HOWARD COUNTY }

MICHAEL HAPP

being duly sworn, deposes and says she is the PUBLISHER

of THE PHONOGRAPH-HERALD a legal weekly newspaper under the Statutes of the State of Nebraska, published in Howard County, Nebraska, and of general circulation in said county, and that the annexed notice has been published in the regular and entire issue of every number of The Phonograph-Herald 1 consecutive weeks, the first publication thereof having been made on the 7th day of August 20 19

PUBLIC HEARING
A public meeting will be held at 7:00 P.M., Monday, August 19, 2019, in the City Council Chambers at 704 6th Street, St. Paul, Nebraska 68873, regarding a new Class I Liquor License application for La Pena Authentic Food LLC dba La Pena Authentic Food (Elvina & Robert J. Rose) at 515 Howard Avenue, St. Paul, Howard County, Nebraska 68873.
Connie Jo Beck
City Clerk,
Deputy Treasurer
City of St. Paul
DATE: August 5, 2019
ZNEZ

Subscribed and sworn to before me this 7th day of August A.D., 20 19

Joyce E. Turpitt
Notary Public

My Commission Expires _____

Printer's Bill:—To publication of above legal notice 20 lines 1 times \$ 6.22

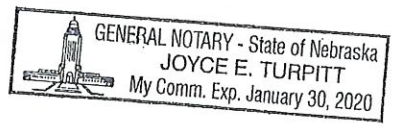

PUBLIC HEARING

A public hearing will be held at 7:00 P. M., Monday, August 19, 2019 in the City Council Chambers at 704 6th Street, St. Paul, Nebraska 68873 regarding a new Class I Liquor License application for La Pena Authentic Food LLC dba La Pena Authentic Food (Elvina & Robert J. Rose) at 515 Howard Avenue, St. Paul, Howard County, Nebraska 68873.



Connie Jo Beck, City Clerk/Deputy Treasurer
City of St. Paul

DATE: August 5, 2019

- Please publish on August 7, 2019

**APPLICATION FOR LIQUOR LICENSE
CHECKLIST - RETAIL**

NEBRASKA LIQUOR CONTROL COMMISSION
301 CENTENNIAL MALL SOUTH
PO BOX 95046
LINCOLN, NE 68509-5046
PHONE: (402) 471-2571
FAX: (402) 471-2814
Website: www.lcc.nebraska.gov

RECEIVED		
JUL 2 nd 2019		
NEBRASKA LIQUOR CONTROL COMMISSION		
Hot List: YES/NO	New/Replacing #	
Class Type <u>I</u>	123018	Initial <u>AD</u>

Applicant name ELVINA ROSE LA Pena Authentic Food LLC

Trade name LA PEÑA AUTHENTIC FOOD LLC.

Previous trade name _____

Contact email address roseelvina372@gmail.com

Provide all the items requested. Failure to provide any item will cause this application to be returned or placed on hold. All documents must be legible. Any false statement or omission may result in the denial, suspension, cancellation or revocation of your license. If your operation depends on receiving a liquor license, the Nebraska Liquor Control Commission cautions you that if you purchase, remodel, start construction, spend or commit money that you do so at your own risk. Prior to submitting your application review the application carefully to ensure that all sections are complete, and that any omissions or errors have not been made. You may want to check with the city/village or county clerk, where you are making application, to see if any additional requirements must be met before submitting application to the Nebraska Liquor Control Commission.

RECEIPT	DATE <u>7/24/19</u> No. 169837
	FROM <u>Elvina Rose</u>
	FOR <u>Application</u>
	<input type="checkbox"/> CASH <input checked="" type="checkbox"/> CHECK # <u>1343</u> \$ <u>400.00</u> <input type="checkbox"/> MONEY# _____ <input type="checkbox"/> ORDER _____ Received by <u>Hauptburmaster</u>

RECEIVED
RMP

Office use only	
PAYMENT TYPE <u>CK #1343</u>	 1900008260
AMOUNT: <u>\$400.00</u>	
Received: <u>AD</u>	

**APPLICATION FOR LIQUOR LICENSE
RETAIL**

NEBRASKA LIQUOR CONTROL COMMISSION
301 CENTENNIAL MALL SOUTH
PO BOX 95046
LINCOLN, NE 68509-5046
PHONE: (402) 471-2571
FAX: (402) 471-2814
Website: www.lcc.nebraska.gov/

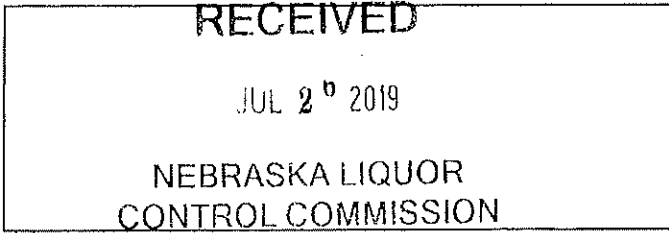

**CLASS OF LICENSE FOR WHICH APPLICATION IS MADE AND FEES
CHECK DESIRED CLASS**

- RETAIL LICENSE(S) Application Fee \$400 (nonrefundable)
- A BEER, ON SALE ONLY
 - B BEER, OFF SALE ONLY
 - C BEER, WINE, DISTILLED SPIRITS, ON AND OFF SALE
 - D BEER, WINE, DISTILLED SPIRITS, OFF SALE ONLY
 - I BEER, WINE, DISTILLED SPIRITS, ON SALE ONLY
 - AB BEER, ON AND OFF SALE
 - AD BEER ON SALE ONLY, BEER, WINE, DISTILLED SPIRITS OFF SALE
 - IB BEER, WINE, DISTILLED SPIRITS ON SALE, BEER OFF SALE ONLY

Class K Catering license (requires catering application form 106) \$100.00

Additional fees will be assessed at city/village or county level when license is issued

Class C license term runs from November 1 – October 31
All other licenses run from May 1 – April 30
Catering license (K) expires same as underlying retail license

CHECK TYPE OF LICENSE FOR WHICH YOU ARE APPLYING

- Individual License (requires insert form 1)
- Partnership License (requires insert form 2)
- Corporate License (requires insert form 3a & 3c)
- Limited Liability Company (LLC) (requires form 3b & 3c)

**NAME OF ATTORNEY OR FIRM ASSISTING WITH APPLICATION (if applicable)
Commission will call this person with any questions we may have on this application**

Name _____ Phone number: _____
Firm Name _____

PREMISES INFORMATION

Trade Name (doing business as) LA PEÑA AUTHENTIC FOOD LLC.

Street Address #1 515 HOWARD AVENUE

Street Address #2 _____

City SAINT PAUL

County HOWARD

Zip Code 68873

Premises Telephone number 308-379-0066

Business e-mail address ROSEELVINA372@GMAIL.COM

Is this location inside the city/village corporate limits: YES NO

Mailing address (where you want to receive mail from the Commission)

Name ELVINA ROSE

Street Address #1 515 HOWARD AVENUE

Street Address #2 _____

City SAINT PAUL

State NE

Zip Code 68873

DESCRIPTION AND DIAGRAM OF THE STRUCTURE TO BE LICENSED
READ CAREFULLY

In the space provided or on an attachment draw the area to be licensed. This should include storage areas, basement, outdoor area, sales areas and areas where consumption or sales of alcohol will take place. If only a portion of the building is to be covered by the license, you must still include dimensions (length x width) of the licensed area as well as the dimensions of the entire building. No blue prints please. Be sure to indicate the direction north and **number of floors** of the building.

****For on premises consumption liquor licenses minimum standards must be met by providing at least two restrooms**

Building: length _____ x width _____ in feet attached floor plan
Is there a basement? Yes _____ No If yes, length _____ x width _____ in feet
Is there an outdoor area? Yes No _____ If yes, length _____ x width _____ in feet

PROVIDE DIAGRAM OF AREA TO BE LICENSED BELOW OR ATTACH SEPARATE SHEET

Burmeister, Tracy

From: Elvina Rose <roseelvina372@gmail.com>
Sent: Monday, July 29, 2019 9:04 PM
To: Burmeister, Tracy
Subject: Dimension

Longest 114.7 feets , widest 22.7 feet

Need dimensions

Longest Point

Widest Point in feet

TOP Form

125-

one story

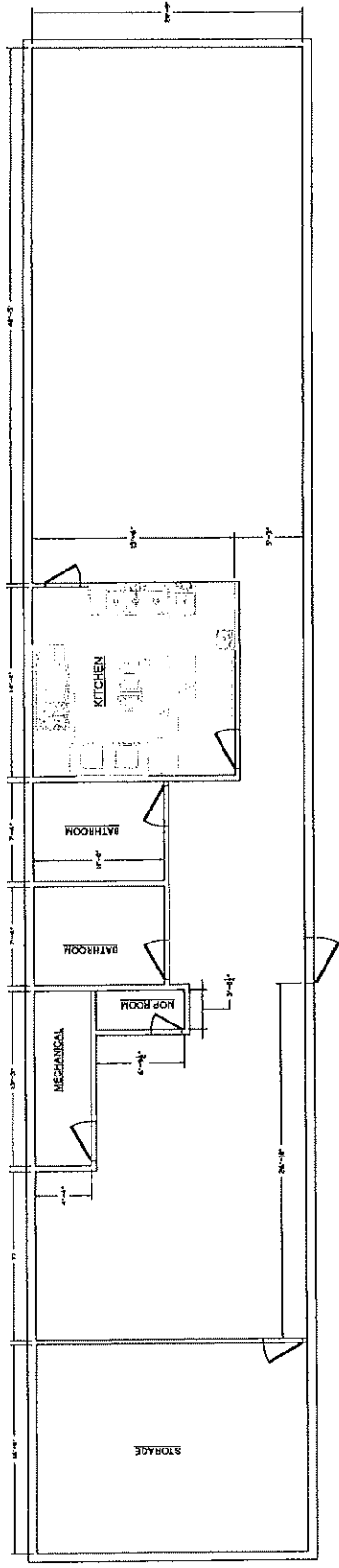

**Special Designated License
Local Recommendation (Form 200)**

Applications must be entered on the portal after local approval – no exceptions
Late applications are non-refundable and will be rejected

Loup River Distilling

Retail Liquor License Name or *Non-Profit Organization (*Must include Form #201 as Page 2)

503 Howard Avenue St Paul NE 68873

Retail Liquor License Address or Non-Profit Business Address

Class ZK #121705 and Class C #121866

Retail License Number or Non-Profit Federal ID #

Consecutive Dates only

Event Date(s): 10-5-19 (Saturday)

Event Start Time(s): 5:00 pm

Event End Time(s): 1:00 am

Alternate Date: No alternate date

Alternate Location Building & Address: 503 Howard Avenue (East Side)

Event Building Name: Twin Loups Quality Meats (East Side)

Event Street Address/City: 805 Howard Avenue St. Paul NE 68873

Indoor area to be licensed in length & width: ___ X ___

Outdoor area to be licensed in length & width: 50' X 150' (Diagram Form #109 must be attached)

Type of Event: Brats & Booze Estimate # of attendees: 100

Type of alcohol to be served: Beer Wine Distilled Spirits
(If not marked, you will not be able to serve this type of alcohol)

Event Contact Name: Eric Montemagni Event Contact Phone Number: (308)754-2242

Event Contact Email: eric@loupriverdistilling.net

*Signature Authorized Representative:  Printed Name Eric Montemagni

I declare that I am the authorized representative of the above named license applicant and that the statements made on this application are true to the best of my knowledge and belief. I also consent to an investigation of my background including all records of every kind including police records. I agree to waive any rights or causes of action against the Nebraska Liquor Control Commission, the Nebraska State Patrol or any other individual releasing said information to the Liquor Control Commission or the Nebraska State Patrol. I further declare that the license applied for will not be used by any other person, group, organization or corporation for profit or not for profit and that the event will be supervised by persons directly responsible to the holder of this Special Designated License.

*Retail licensee – Must be signed by a member listed on permanent license
*Non-Profit Organization – Must be signed by a Corporate Officer

Identification will be checked,
along with wristbands being
utilized for underage drinking

Local Governing Body completes below:

The local governing body for the City/Village of St Paul OR County of _____ approves
the issuance of a Special Designated License as requested above. (Only one should be written above)

Local Governing Body Authorized Signature

Date



OUTDOOR AREA DIAGRAM

HOW AREA WILL BE PATROLLED Loup River Distilling staff, along with City of
St. Paul Police Department

- IF APPLICABLE, OUTDOOR AREA MUST BE CONNECTED TO INDOOR AREA IF INDOOR AREA IS TO LICENSED
- MEASUREMENT OF OUTER WALLS OF AREA TO BE LICENSED MUST INCLUDED LENGTH & WIDTH IN FEET
- DOUBLE FENCING IS REQUIRED FOR ALL NON-PROFIT ORGANIZATIONS UNLESS FORM #140 IS FILED WITH THIS FORM AND IS APPROVED BY THE COMMISSION
- RETAILER LIQUOR LICENSE HOLDERS ARE NOT REQUIRED TO DOUBLE FENCE, ALTHOUGH MEASURES NEED TO BE TAKEN TO SECURE THE AREA

DIAGRAM OF PROPOSED AREA:

"See Attachment"

Fence panels will surround the east side of Twin Loup's Quality Meats at 805 Howard Avenue on 8th Street between Howard Avenue and Grand Street.

Caterers must have a valid Nebraska Liquor Control Commission license, including a Special Designated License (SDL). **MINORS ABSOLUTELY WILL NOT BE SERVED ALCOHOLIC BEVERAGES.** All caterers shall be solely and completely responsible for the liquor permit and any resulting violations.

The CITY OF ST. PAUL will assume NO responsibility for problems, legal or otherwise, which could result from consuming alcoholic beverages in the City Limits of the CITY OF ST. PAUL.

Insurance Requirements: Anyone serving liquor in the City Limits of the CITY OF ST. PAUL is required to have at least One Million Dollars (\$1,000,000.00) in general liability insurance. The CITY OF ST. PAUL must be listed as an Additional Insured. They must also have liquor liability insurance in an amount of at least \$100,000 per occurrence / \$300,000 aggregate. Proof of insurance must be provided prior to the City Council meeting for approval of the Special Designated License (SDL).

AGREEMENT OF ALCOHOL CATERER

EVENT: Brats & Booze Social Event DATE: 8-12-2019
October 5, 2019

The undersigned acknowledges that it will be the CATERER of alcoholic beverages in the City Limits of the CITY OF ST. PAUL.

1. CATERER shall follow all laws and rules regarding the provision of alcoholic beverages within the City Limits of the CITY OF ST. PAUL.
2. CATERER has a general liability insurance policy in effect in an amount not less than \$1,000,000.00. CATERER shall list the CITY OF ST. PAUL as an Additional Insured on said policy. CATERER also has a liquor liability policy in effect in an amount not less than \$100,000 per occurrence / \$300,000 aggregate. CATERER shall provide CITY proof of said insurance for catering alcohol in the City Limits of the CITY OF ST. PAUL.
3. All responsibilities for damages or problems, legal or otherwise, which might result from providing alcoholic beverages in the City Limits of the CITY OF ST. PAUL, shall be assumed by CATERER and CATERER agrees to hold the CITY harmless from any liability and indemnify the CITY OF ST. PAUL for any costs incurred arising from CATERER's services in the City Limits of the CITY OF ST. PAUL.
4. It is agreed that the terms of this agreement are contractual and not mere recitals and are binding upon the parties hereto, their successors, heirs, personal representatives, and assigns.
5. If any provision or paragraph of this agreement is unenforceable, the remaining provisions or paragraphs shall nevertheless be carried into effect.

CITY OF ST. PAUL, NEBRASKA

DATE: 8-12-2019

BY: 
City of St. Paul Designated Agent
Connie Jo Beck, City Clerk

CATERER NAME: Loup River Distilling - Eric Montemagni

DATE: 8-12-2019

BY: 
Authorized Agent of Caterer

Connie Beck

From: Carissa Stepanek <CStepanek@christenseninsurance.com>
Sent: Wednesday, August 14, 2019 3:17 PM
To: Connie Beck
Subject: Eric Montemagni

Good Afternoon Connie!

Eric is currently insured through an agency out of Wyoming. We are in the process of transferring his coverage to our office but will not have access to his policies until Monday at the earliest. We do know his current liability limits are \$1,000,000 / \$2,000,000 for general liability. We will send the new information to you once we have it. Please let me know if you have any questions. Have a great day!

Thank you,

Carissa Stepanek

Christensen Insurance
P.O. Box 266
Saint Paul, NE 68873
800-570-2892
308-754-5467
Fax 308-754-5468
cstepanek@christenseninsurance.com



NOTICE - CONFIDENTIAL INFORMATION

The information in this communication is proprietary and strictly confidential. It is intended solely for the use of the individual or entity named above. If the reader of this message is not the intended recipient, or the employee or agent responsible to deliver it to the intended recipient, any dissemination, distribution, copying or other use of the information contained in this communication is strictly prohibited. If you have received this communication in error, please first notify the sender immediately and then delete this communication from all data storage devices and destroy all hard copies.

ExchangeDefender Message Security: [Check Authenticity](#)

***Fence will be placed south of alley of
Twin Loups Quality Meats building.







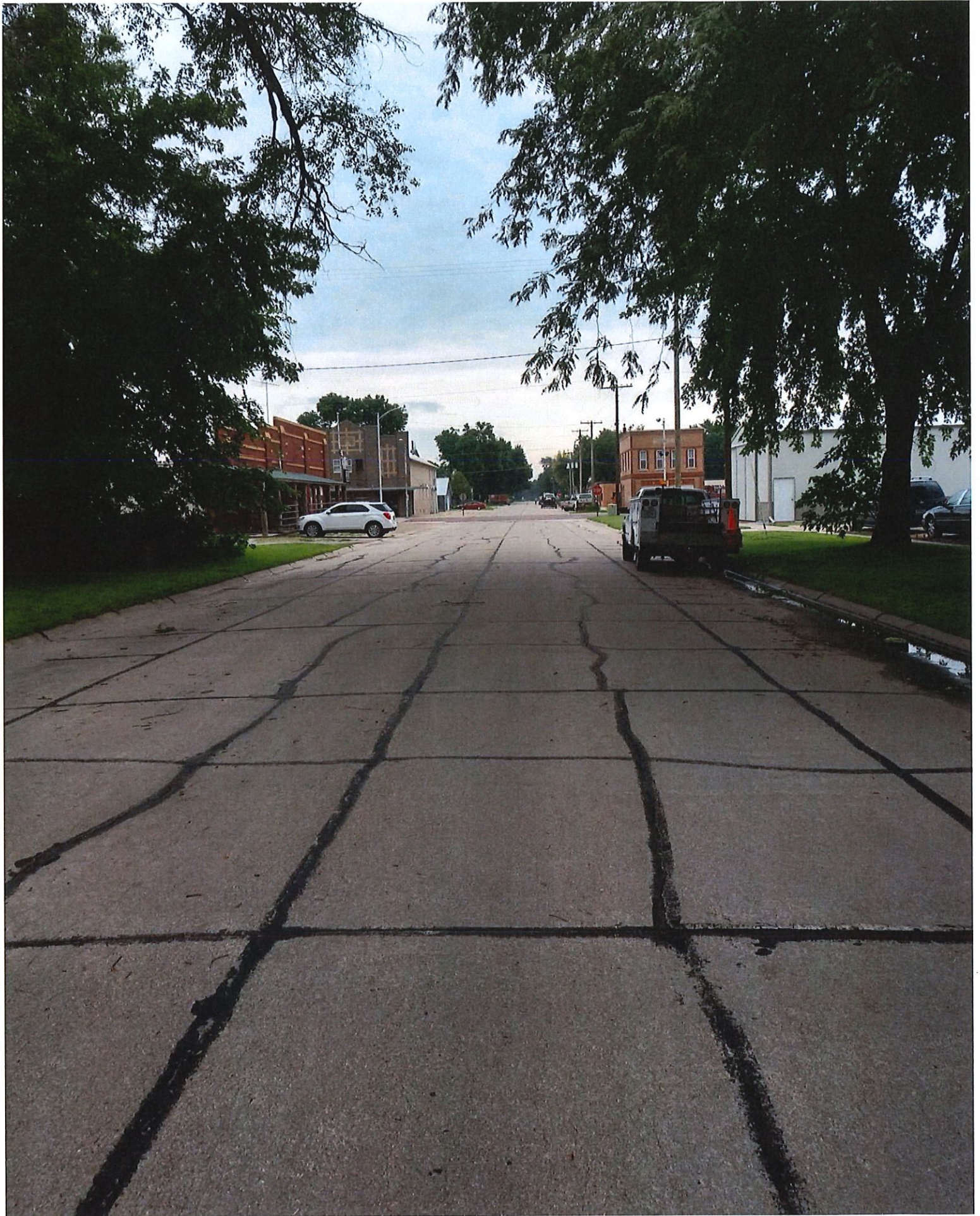

PI-GLD-CBD(02/15)

THIS ENDORSEMENT CHANGES THE POLICY. PLEASE READ IT CAREFULLY.**GENERAL LIABILITY DELUXE ENDORSEMENT:
CRAFT BREWERIES AND DISTILLERIES**

This endorsement modifies insurance provided under the following:

COMMERCIAL GENERAL LIABILITY COVERAGE

It is understood and agreed that the following extensions only apply in the event that no other specific coverage for the indicated loss exposure is provided under this policy. If such specific coverage applies, the terms, conditions and limits of that coverage are the sole and exclusive coverage applicable under this policy, unless otherwise noted on this endorsement. The following is a summary of the Limits of Insurance and additional coverages provided by this endorsement. For complete details on specific coverages, consult the policy contract wording.

Coverage Applicable	Limit of Insurance	Page #
Damage to Premises Rented to You	\$1,000,000	2
Product Withdrawal Expense	\$20,000	2
Expected or Intended Injury – Property Damage	Included	7
Supplementary Payments – Bail Bonds	\$2,500	8
Supplementary Payments – Loss of Earnings	\$500 per day	8
Employee Indemnification Defense Coverage	\$25,000	8
Who Is An Insured Additional Insured – Newly Acquired or Formed Organizations Additional Insured – Managers and Supervisors (with Fellow Employee Coverage) Additional Insured – Broadened Named Insured Additional Insured – Blanket Additional Insureds When Required by Contract Additional Insured – Managers, Landlords, or Lessors of Premises Additional Insured – Lessors of Leased Equipment Additional Insured – Vendors Additional Insured – Owners, Lessees, or Contractors	Included	8
Duties in the Event of Occurrence, Offense, Claim or Suit	Included	10
Unintentional Failure to Disclose Hazards	Included	11
Transfer of Rights of Recovery Against Others To Us	Clarification	11
Liberalization	Included	11
Bodily Injury – Includes Mental Anguish	Included	12
Personal and Advertising Injury – Includes Abuse of Process, Discrimination	Included	12

PI-GLD-CBD (02/15)

Page 1 of 12

Includes copyrighted material of Insurance Services Office, Inc., with permission.
© 2015 Philadelphia Consolidated Holding Corp.

PI-GLD-CBD(02/15)

A. Damage to Premises Rented to You

If damage by fire to premises rented to you is not otherwise excluded from this Coverage Part:

1. The Damage To Premises Rented To You Limit section of the Declarations is amended to the greater of:

- a. \$1,000,000; or

- b. The amount shown in the Declarations as the Damage to Premises Rented to You Limit.

This is the most we will pay for all damage proximately caused by the same event, whether such damage results from fire, lightning, explosion, smoke, or leaks from automatic fire protective systems or any combination thereof;

2. The word fire is changed to fire, lightning, explosion, smoke, or leakage from automatic fire protective systems where it appears in:
 - a. The last paragraph of **SECTION I – COVERAGES, COVERAGE A BODILY INJURY AND PROPERTY DAMAGE LIABILITY**, Subsection 2. Exclusions;
 - b. **SECTION III – LIMITS OF INSURANCE**, Paragraph 6.; and
 - c. **SECTION V – DEFINITIONS**, Paragraph 9.a.; and
3. The words fire insurance are changed to insurance for fire, lightning, explosion, smoke, or leakage from automatic fire protective systems where it appears in **SECTION IV – COMMERCIAL GENERAL LIABILITY CONDITIONS**, Subsection 4. Other Insurance, Paragraph b. Excess Insurance.

B. Product Withdrawal Expense

THIS COVERAGE PROVIDES REIMBURSEMENT TO YOU FOR EXPENSES INCURRED BECAUSE OF A COVERED "PRODUCT WITHDRAWAL." IT DOES NOT PROVIDE ANY LIABILITY COVERAGE OR COVERAGE FOR THE COST OR EXPENSE OF DEFENDING ANY CLAIM, SUIT, ADMINISTRATIVE ACTION OR OTHER CIVIL OR CRIMINAL PROCEEDING.

SECTION I – COVERAGES is amended to include the following additional coverage:

1. Insuring Agreement

- a. We will reimburse you for "product withdrawal expenses" incurred by you because of a "product withdrawal" to which this insurance applies. The amount of such reimbursement is limited as described in Paragraph 3. below. No other obligation or liability to pay sums or perform acts or services is covered.
- b. This insurance applies to a "product withdrawal" only if the "product withdrawal" is initiated in the "coverage territory" during the policy period because:
 - (1) You determine that the "product withdrawal" is necessary; or
 - (2) An authorized government entity has ordered you to conduct a "product withdrawal."

PI-GLD-CBD (02/15)

Page 2 of 12

Includes copyrighted material of Insurance Services Office, Inc., with permission.
© 2015 Philadelphia Consolidated Holding Corp.

PI-GLD-CBD(02/15)

- c. We will reimburse "product withdrawal expenses" only if:
- (1) The expenses are incurred within one year of the date the "product withdrawal" was initiated;
 - (2) The expenses are reported to us within one year of the date the expenses were incurred; and
 - (3) The product that is the subject of the "product withdrawal" was produced after the effective date of the policy.
- d. The initiation of a "product withdrawal" will be deemed to have been made only at the earliest of the following times:
- (1) When you first announced, in any manner, to the general public, your vendors or to your employees (other than those employees directly involved in making the determination) your decision to conduct or participate in a "product withdrawal." This applies regardless of whether the determination to conduct a "product withdrawal" is made by you or is requested by a third party; or
 - (2) When you first received, either orally or in writing, notification of an order from an authorized government entity to conduct a "product withdrawal."
- e. "Product withdrawal expenses" incurred to withdraw "your products" which contain the same or substantially similar "defects" will be deemed to have arisen out of the same "product withdrawal."

2. Exclusions

This insurance does not apply to "product withdrawal expenses" arising out of:

a. Breach Of Warranty And Failure To Conform To Intended Purpose

Any "product withdrawal" initiated due to the failure of "your product" to accomplish its intended purpose, including any breach of warranty of fitness, whether written or implied. This exclusion does not apply if such failure has caused or is reasonably expected to cause "bodily injury" or physical damage to tangible property other than "your product."

b. Infringement Of Copyright, Patent, Trade Secret, Trade Dress Or Trademark

Any "product withdrawal" initiated due to copyright, patent, trade secret, trade dress, or trademark infringements.

c. Deterioration, Decomposition or Chemical Transformation

Any "product withdrawal" initiated due to transformation of a chemical nature, deterioration or decomposition of "your product." This exclusion does not apply if such deterioration, decomposition or transformation is caused by:

- (1) An error in manufacturing, design, or processing;
- (2) Transportation of "your product"; or

PI-GLD-CBD (02/15)

Page 3 of 12

Includes copyrighted material of Insurance Services Office, Inc., with permission.
© 2015 Philadelphia Consolidated Holding Corp.

PI-GLD-CBD(02/15)

(3) "Product tampering."

d. Goodwill, Market Share, Revenue, Profit Or Redesign

The costs of regaining goodwill, market share, revenue or "profit" or the cost of redesigning "your product."

e. Expiration Of Shelf Life

Any "product withdrawal" initiated due to the expiration of the designated shelf life of "your product."

f. Known Defect

A "product withdrawal," initiated because of a "defect" in "your product" known to exist by the Named Insured or the Named Insured's "executive officers," prior to the date when this Coverage Part was first issued to you or prior to the time "your product" leaves your control or possession.

g. Otherwise Excluded Products

A recall of any specific products for which "bodily injury" or "property damage" is excluded under **COVERAGE A – BODILY INJURY AND PROPERTY DAMAGE LIABILITY** by endorsement.

h. Governmental Ban

A recall when "your product" or a component contained within "your product" has been:

(1) Banned from the market by an authorized government entity prior to the policy period;
or

(2) Distributed or sold by you subsequent to any governmental ban.

i. Defense Of Claim

The defense of a claim or "suit" against you for liability arising out of a "product withdrawal."

j. Third Party Damages, Fines and Penalties

Any compensatory damages, fines, penalties, punitive or exemplary or other non-compensatory damages imposed upon the insured.

k. Pollution-related Expenses

Any loss, cost or expense due to any:

(1) Request, demand order, statutory or regulatory requirement that any insured or others test for, monitor, clean up, remove, contain, treat, detoxify or neutralize, or in any way respond to, or assess the effects of, "pollutants"; or

PI-GLD-CBD (02/15)

Page 4 of 12

Includes copyrighted material of Insurance Services Office, Inc., with permission.
© 2015 Philadelphia Consolidated Holding Corp.

PI-GLD-CBD(02/15)

- (2) Claim or suit by or on behalf of a governmental authority for damages because of testing for, monitoring, cleaning up, removing, containing, treating, detoxifying or neutralizing, or in any way responding to, or assessing the effects of, "pollutants."

3. Limits of Insurance and Deductible

For the purposes of this endorsement, **SECTION III – LIMITS OF INSURANCE** is deleted in its entirety and replaced with the following:

- a. The most we will reimburse you for the sum of all "product withdrawal expenses" incurred for all "product withdrawals" initiated during the policy period is \$20,000 aggregate.
- b. This limit is the most we will pay regardless of the number of:
- (1) Insureds;
 - (2) "Product withdrawals" initiated; or
 - (3) Number of "your products" withdrawn.
- c. We will only pay for the amount of "product withdrawal expenses" which are in excess of a \$1,000 deductible. This deductible applies separately to each "product withdrawal." The \$20,000 aggregate limit will not be reduced by the amount of this deductible.

We may, or will if required by law, pay all or any part of the deductible amount. Upon notice of our payment of a deductible amount, you shall promptly reimburse us for the part of the deductible amount we paid.

4. Conditions

For the purposes of this additional coverage:

- a. The **Duties In The Event of Occurrence, Claim Or Suit** condition under **SECTION IV – CONDITIONS** is replaced by the following:

Duties in the Event of a "Defect" Or a "Product Withdrawal"

- (1) You must see to it that we are notified as soon as practicable of any actual, suspected or threatened "defect" in "your product," or any governmental investigation, that may result in a "product withdrawal." To the extent possible, notice should include:
- (a) How, when and where the "defect" was discovered;
 - (b) The names and addresses of any injured persons and witnesses; and
 - (c) The nature, location and circumstances of any injury or damage arising out of use or consumption of "your product."
- (2) If a "product withdrawal" is initiated, you must:
- (a) Immediately record the specifics of the "product withdrawal" and the date it was initiated; and

PI-GLD-CBD (02/15)

Page 5 of 12

Includes copyrighted material of Insurance Services Office, Inc., with permission.
© 2015 Philadelphia Consolidated Holding Corp.

PI-GLD-CBD(02/15)

(b) Notify us as soon as practicable.

You must see to it that we receive written notice of the "product withdrawal" as soon as practicable.

(3) You must promptly take all reasonable steps to mitigate the expenses associated with a "product withdrawal." Any "profit" that you receive from mitigating the expenses will be deducted for the amount of reimbursement that you will receive for "product withdrawal expense."

(4) You and any other involved insured must:

(a) Immediately send us copies of pertinent correspondence received in connection with the "product withdrawal";

(b) Authorize us to obtain records and other information; and

(c) Cooperate with us in our investigation of the "product withdrawal."

b. The following additional condition is included under **SECTION IV – CONDITIONS:**

Concealment Or Fraud

We will not provide this additional coverage to you, or to any other insured, who at any time:

(1) Engaged in fraudulent conduct; or

(2) Intentionally concealed or misrepresented a material fact concerning a "product withdrawal" or "product withdrawal expense" incurred by you under this additional coverage.

5. Definitions

For the purposes of this additional coverage, the following definitions apply:

a. "Defect" means a defect, deficiency or inadequacy that creates a dangerous condition.

b. "Product tampering" is an act of intentional alteration of "your product" which has caused or is reasonably expected to cause "bodily injury" or physical injury to tangible property other than "your product."

When "product tampering" is known, suspected or threatened, a "product withdrawal" will be limited to those batches of "your product" which are known or suspected to have been tampered with.

For the purpose of this insurance, electronic data is not tangible property.

As used in this definition, electronic data means information, facts or programs stored as or on, created or used on, or transmitted to or from computer software, including systems and applications software, hard or floppy disks, CD-ROMs, tapes, drives, cells, data processing devices or any other media which are used with electronically controlled equipment.

c. "Product withdrawal" means the recall or withdrawal:

PI-GLD-CBD (02/15)

Page 6 of 12

Includes copyrighted material of Insurance Services Office, Inc., with permission.

© 2015 Philadelphia Consolidated Holding Corp.

PI-GLD-CBD(02/15)

- (1) From the market; or
- (2) From use by any other person or organization:

of "your products," or products which contain "your products" because of known or suspected "defects" in "your product," or known or suspected "product tampering," which has caused or is reasonably expected to cause "bodily injury" or physical injury to tangible property other than "your product."

For the purpose of this insurance, electronic data is not tangible property.

As used in this definition, electronic data means information, facts or programs stored as or on, created or used on, or transmitted to or from computer software, including systems and applications software, hard or floppy disks, CD-ROMs, tapes, drives, cells, data processing devices or any other media which are used with electronically controlled equipment.

- d. "Product withdrawal expenses" means reasonable and necessary extra expenses, listed below, paid and directly related to a "product withdrawal":
 - (1) Costs of notification;
 - (2) Costs of stationery, envelopes, production of announcements and postage or facsimiles;
 - (3) Costs of overtime paid to your regular non-salaried employees and costs incurred by your employees, including costs of transportation and accommodations;
 - (4) Costs of computer time;
 - (5) Costs of hiring independent contractors and other temporary employees;
 - (6) Costs of transportation, shipping or packaging;
 - (7) Costs of warehouse or storage space; or
 - (8) Costs of proper disposal of "your products," or products that contain "your products," that cannot be reused, not exceeding your purchase price or your cost to produce the products.
- e. "Profit" means the positive gain from business operation after subtracting all expenses.

C. Expected or Intended Injury – Property Damage

SECTION I – COVERAGES, COVERAGE A BODILY INJURY AND PROPERTY DAMAGE LIABILITY, 2. Exclusions, Paragraph a. Expected Or Intended Injury is deleted in its entirety and replaced by the following:

a. Expected Or Intended Injury

"Bodily injury" or property damage" expected or intended from the standpoint of the insured. This exclusion does not apply to "bodily injury" or "property damage" resulting from the use of reasonable force to protect persons or property.

PI-GLD-CBD (02/15)

Page 7 of 12

Includes copyrighted material of Insurance Services Office, Inc., with permission.
© 2015 Philadelphia Consolidated Holding Corp.

PI-GLD-CBD(02/15)

D. Supplementary Payments

SECTION I – COVERAGES, SUPPLEMENTARY PAYMENTS – COVERAGES A AND B, Items 1.b. and 1.d. are amended as follows:

- b. The limit for the cost of bail bonds is changed from \$250 to \$2,500; and
- d. The limit for loss of earnings is changed from \$250 a day to \$500 a day.

E. Employee Indemnification Defense Coverage

SECTION I – COVERAGES, SUPPLEMENTARY PAYMENTS – COVERAGES A AND B is amended to include the following:

We will pay, on your behalf, defense costs incurred by an "employee" in a criminal proceeding resulting from their duties related to the conduct of your business.

The most we will pay for any "employee" who is directly involved in a criminal proceeding is \$25,000 regardless of the number of "employees," claims or "suits" brought or persons or organizations making claims or bringing "suits."

F. Who is An Insured

SECTION II – WHO IS AN INSURED is amended as follows:

1. Newly Acquired or Formed Organizations

If coverage for newly acquired or formed organizations is not otherwise excluded from this Coverage Part, Paragraph **3.a.** is amended to read:

- a. Coverage under this provision is afforded until the end of the policy period;

2. Each of the following is also an insured:

- a. **Managers and Supervisors** – Your managers and supervisors are also insureds, but only with respect to their duties as your managers and supervisors. Managers and supervisors who are your "employees" are also insureds for "bodily injury" to a co-"employee" while in the course of his or her employment by you or performing duties related to the conduct of your business.

This provision does not change Item 2.a.(1)(a) as it applies to managers of a limited liability company.

- b. **Broadened Named Insured** – Any organization and subsidiary thereof which you control and actively manage on the effective date of this Coverage Part. However, coverage does not apply to any organization or subsidiary not named in the Declarations as Named Insured, if they are also insured under another similar policy, but for its termination or the exhaustion of its limits of insurance.
- c. **Blanket Additional Insureds When Required by Contract** – Any person or organization where required by a written contract executed prior to the occurrence of a loss. Such person or organization is an additional insured for "bodily injury," "property damage" or "personal and advertising injury" but only for liability arising out of the negligence of the named insured. The

PI-GLD-CBD (02/15)

Page 8 of 12

Includes copyrighted material of Insurance Services Office, Inc., with permission.
© 2015 Philadelphia Consolidated Holding Corp.

PI-GLD-CBD(02/15)

limits of insurance applicable to these additional insureds are the lesser of the policy limits or those limits specified in a contract or agreement. These limits are included within and not in addition to the limits of insurance shown in the Declarations.

- d. **Managers, Landlords, or Lessors of Premises** – Any person or organization with respect to their liability arising out of the ownership, maintenance or use of that part of the premises leased or rented to you subject to the following additional exclusions:

This insurance does not apply to:

- (1) Any "occurrence" which takes place after you cease to be a tenant in that premises; or
- (2) Structural alterations, new construction or demolition operations performed by or on behalf of that person or organization.

- e. **Lessors of Leased Equipment – Automatic Status When Required in Lease Agreement With You** – Any person or organization from whom you lease equipment when you and such person or organization have agreed in writing in a contract or agreement that such person or organization is to be added as an additional insured on your policy. Such person or organization is an insured only with respect to liability for "bodily injury," "property damage" or "personal and advertising injury" caused, in whole or in part, by your maintenance, operation or use of equipment leased to you by such person or organization.

A person's or organization's status as an additional insured under this endorsement ends when their contract or agreement with you for such leased equipment ends.

With respect to the insurance afforded to these additional insureds, this insurance does not apply to any "occurrence" which takes place after the equipment lease expires.

- f. **Vendors** – Only with respect to "bodily injury" or "property damage" arising out of "your products" which are distributed or sold in the regular course of the vendor's business, subject to the following additional exclusions:

(1) The insurance afforded the vendor does not apply to:

- (a) "Bodily injury" or "property damage" for which the vendor is obligated to pay damages by reason of the assumption of liability in a contract or agreement. This exclusion does not apply to liability for damages that the vendor would have in the absence of the contract or agreement;
- (b) Any express warranty unauthorized by you;
- (c) Any physical or chemical change in the product made intentionally by the vendor;
- (d) Repackaging, except when unpacked solely for the purpose of inspection, demonstration, testing, or the substitution of parts under instructions from the manufacturer, and then repackaged in the original container;
- (e) Any failure to make such inspections, adjustments, tests or servicing as the vendor has agreed to make or normally undertakes to make in the usual course of business, in connection with the distribution or sale of the products;

PI-GLD-CBD (02/15)

Page 9 of 12

Includes copyrighted material of Insurance Services Office, Inc., with permission.
© 2015 Philadelphia Consolidated Holding Corp.

PI-GLD-CBD(02/15)

- (f) Demonstration, installation, servicing or repair operations, except such operations performed at the vendor's premises in connection with the sale of the product;
 - (g) Products which, after distribution or sale by you, have been labeled or relabeled or used as a container, part or ingredient of any other thing or substance by or for the vendor; or
 - (h) "Bodily injury" or "property damage" arising out of the sole negligence of the vendor for its own acts or omissions or those of its employees or anyone else acting on its behalf. However, this exclusion does not apply to:
 - (i) The exceptions contained in Sub-paragraphs (d) or (f); or
 - (ii) Such inspections, adjustments, tests or servicing as the vendor has agreed to make or normally undertakes to make in the usual course of business, in connection with the distribution or sale of the products.
- (2) This insurance does not apply to any insured person or organization, from whom you have acquired such products, or any ingredient, part or container, entering into, accompanying or containing.
- g. Owners, Lessees or Contractors** – Any person or organization, but only with respect to liability for "bodily injury," "property damage" or "personal and advertising injury" caused, in whole or in part, by:

- (1) Your acts or omissions; or
- (2) The acts or omissions of those acting on your behalf;

in the performance of your ongoing operations for the additional insured when required by a contract.

With respect to the insurance afforded to these additional insureds, the following additional exclusions apply:

This insurance does not apply to "bodily injury" or "property damage" occurring after:

- (a) All work, including materials, parts or equipment furnished in connection with such work, on the project (other than service, maintenance or repairs) to be performed by or on behalf of the additional insured(s) at the location of the covered operations has been completed; or
- (b) That portion of "your work" out of which the injury or damage arises has been put to its intended use by any person or organization other than another contractor or subcontractor engaged in performing operations for a principal as a part of the same project.

G. Duties in the Event of Occurrence, Offense, Claim or Suit

1. **SECTION IV – COMMERCIAL GENERAL LIABILITY CONDITIONS**, 2.a.the requirement that you must see to it that we are notified as soon as practicable of an "occurrence" or an offense, applies only when the "occurrence" or offense is known to:

PI-GLD-CBD (02/15)

Page 10 of 12

Includes copyrighted material of Insurance Services Office, Inc., with permission.
© 2015 Philadelphia Consolidated Holding Corp.

PI-GLD-CBD(02/15)

- a. You, if you are an individual;
 - b. A partner, if you are a partnership; or
 - c. An "executive officer" or insurance manager, if you are a corporation.
2. **SECTION IV – COMMERCIAL GENERAL LIABILITY CONDITIONS, 2.** b. the requirement that you must see to it that we receive notice of a claim or "suit" as soon as practicable will not be considered breached unless the breach occurs after such claim or "suit" is known to:
- a. You, if you are an individual;
 - b. A partner, if you are a partnership; or
 - c. An "executive officer" or insurance manager, if you are a corporation.
3. **SECTION IV – COMMERCIAL GENERAL LIABILITY CONDITIONS, 2.** is amended to include the following additional provision:

Your rights under this coverage part will not be prejudiced if you fail to give us notice of an "occurrence," offense, claim or "suit" and that failure is solely due to your reasonable belief that the "bodily injury" or "property damage" is not covered under this coverage part. However, you shall give written notice of this "occurrence," offense, claim or "suit" to us as soon as you are aware that this insurance may apply to such "occurrence", offense claim or "suit."

H. Unintentional Failure To Disclose Hazards

SECTION IV – COMMERCIAL GENERAL LIABILITY CONDITIONS, 6. Representations is amended to include the following provision:

It is agreed that, based on our reliance on your representations as to existing hazards, if you should unintentionally fail to disclose all such hazards prior to the beginning of the policy period of this Coverage Part, we shall not deny coverage under this Coverage Part because of such failure.

I. Transfer of Rights of Recovery Against Others To Us

SECTION IV – COMMERCIAL GENERAL LIABILITY CONDITIONS, 8. Transfer of Rights of Recovery Against Others To Us includes the following clarification:

Therefore, the insured can waive the insurer's rights of recovery prior to the occurrence of a loss, provided the waiver is made in a written contract.

J. Liberalization

SECTION IV – COMMERCIAL GENERAL LIABILITY CONDITIONS, is amended to include the following additional condition:

Liberalization

If we revise this endorsement to provide more coverage without additional premium charge, we will automatically provide the additional coverage to all endorsement holders as of the day the revision is effective in your state.

PI-GLD-CBD (02/15)

Page 11 of 12

Includes copyrighted material of Insurance Services Office, Inc., with permission.
© 2015 Philadelphia Consolidated Holding Corp.

PI-GLD-CBD(02/15)

K. Bodily Injury – Mental Anguish

SECTION V – DEFINITIONS, Paragraph 3. is amended to read:

"Bodily injury":

- a. Means bodily injury, sickness or disease sustained by a person, and includes mental anguish resulting from any of these; and
- b. Except for mental anguish, includes death resulting from the foregoing (Item a. above) at any time.

L. Personal and Advertising Injury – Abuse of Process, Discrimination

If **COVERAGE B PERSONAL AND ADVERTISING INJURY LIABILITY COVERAGE** is not otherwise excluded from this Coverage Part, the definition of "personal and advertising injury" is amended as follows:

1. **SECTION V – DEFINITIONS, Paragraph 14., Item b.** is revised to read:

- b. Malicious prosecution or abuse of process;

2. **SECTION V – DEFINITIONS, Paragraph 14.** is amended to include the following:

"Personal and advertising injury" also means discrimination based on race, color, religion, sex, age or national origin, except when:

- a. Done intentionally by or at the direction of, or with the knowledge or consent of:
 - (1) Any insured; or
 - (2) Any executive officer, director, stockholder, partner or member of the insured;
- b. Directly or indirectly related to the employment, former or prospective employment, termination of employment, or application for employment of any person or persons by an insured;
- c. Directly or indirectly related to the sale, rental, lease or sublease or prospective sale, rental, lease or sub-lease of any room, dwelling or premises by or at the direction of any insured; or
- d. Insurance for such discrimination is prohibited by or held in violation of law, public policy, legislation, court decision or administrative ruling.

The above does not apply to fines or penalties imposed because of discrimination.

PI-GLD-CBD (02/15)

Page 12 of 12

Includes copyrighted material of Insurance Services Office, Inc., with permission.
© 2015 Philadelphia Consolidated Holding Corp.

St. Paul Fire Department

824 6th. Street
St. Paul, NE 68873

Phone (308) 754-5254

EMT

MEMBERSHIP APPLICATION

I Tyler Moslander

would like to become a member of the ST. PAUL FIRE DEPARTMENT & RESCUE SQUAD. I have had the duties and responsibilities explained to me, and I willingly accept the responsibility of becoming a member of the ST. PAUL FIRE DEPARTMENT if I am accepted by the ST. PAUL FIRE DEPARTMENT and the ST. PAUL CITY COUNCIL and ST. PAUL RURAL FIRE PROTECTION BOARD.

[Signature]
SIGNATURE OF APPLICANT

06-29-19
DATE

[Signature]
SIGNATURE OF SPFD TRUSTEE

8-8-19
DATE

[Signature]
SIGNATURE OF SPFD TRUSTEE

8/8/19
DATE

[Signature] - Chief
SIGNATURE OF SPFD TRUSTEE

8-8-19
DATE

Applicant information: NAME Tyler Moslander
ADDRESS 322 Chest. St. Paul
NE 68873
BIRTHDATE 03-12-1999
PHONE 402-355-0645
EMT LICENSE # _____
DRIVERS LICENSE # H13711437
SOCIAL SECURITY # _____

*Voted yes by Majority EMT at Meeting 7-29-19
[Signature] 501*

*Voted yes by majority at Fire meeting
[Signature] Kopinski 8/8/19*

St. Paul Fire Department

754 7836

824 6th. Street
St. Paul, NE 68873

Phone (308) 754-5254

Fire
INS

MEMBERSHIP APPLICATION

I Travis Williams would like to become a member of the ST. PAUL FIRE DEPARTMENT & RESCUE SQUAD. I have had the duties and responsibilities explained to me, and I willingly accept the responsibility of becoming a member of the ST. PAUL FIRE DEPARTMENT if I am accepted by the ST. PAUL FIRE DEPARTMENT and the ST. PAUL CITY COUNCIL and ST. PAUL RURAL FIRE PROTECTION BOARD.

<u>[Signature]</u> SIGNATURE OF APPLICANT	<u>5-16-2018</u> DATE
<u>[Signature]</u> SIGNATURE OF SPFD TRUSTEE	<u>8-8-19</u> DATE
<u>[Signature]</u> SIGNATURE OF SPFD TRUSTEE	<u>8-8-19</u> DATE
<u>[Signature]</u> SIGNATURE OF SPFD TRUSTEE	<u>8-8-19</u> DATE

Applicant information: NAME Travis Williams
 ADDRESS 1523 Hwy 281
 BIRTHDATE 2-11-88
 PHONE 308 627-1519
 EMT LICENSE # _____
 DRIVERS LICENSE # H12983677
 SOCIAL SECURITY # _____

Voted Yes by Majority
at Fire Dept Meeting
[Signature] 8-8-19

Connie Beck

From: Brian Friedrichsen <bfriedrichsen@olsson.com>
Sent: Thursday, August 8, 2019 4:35 PM
To: Matt Helzer; Connie Beck
Subject: St. Paul Water Relocation - 4" Main Under Green Houses

Matt/Connie,

We took a look at what we feel it would take to complete the work to relocate the 4" water main under the green houses on Howard Avenue and tie the main into the Highway 281 8" main. We will need to get some topographic survey done as well as some research on the existing east/west alley to be sure we are putting the new main in the correct location. There will also be the design aspect, HHS approval, as well as acquiring an NDOT permit to work on the states right-of-way.

For all the above work, we are anticipating \$5,500.00. We will complete this work on and time and material not to exceed basis meaning that if we do not use the entire budget, the City will not be billed for the full amount. We wouldn't need to set up a new project number and could work under the City's already existing 2019 Consulting Services project if so desired. Please let myself or Jeff know if you would like to proceed with this project. If you have any questions or would like me or Jeff to attend a council meeting please let me know.

Thanks,

Brian J. Friedrichsen, PE

Civil

D 308.398.2946

C 308.750.4326

201 E. Second Street
Grand Island, NE 68801
O 308.384.8750

olsson[®]

Follow Us: [Facebook](#) / [Twitter](#) / [Instagram](#) / [LinkedIn](#) / [YouTube](#)

[View Legal Disclaimer](#)

STATE OF NEBRASKA, County of

Filed for record on 19 at o'clock M.

and recorded in the Deed Record Page

By Register of Deeds Deputy Register of Deeds

SURVIVORSHIP WARRANTY DEED

Gladys Schack, a single person, Garnet Schack, a single person, Grace Sorensen and Harold E. Sorensen, wife and husband, each in her and his own right, and as spouse of the other, and Jennie Johnson, a widow and now a single person, herein called the grantor whether one or more,

in consideration of Five Thousand and No/100-----DOLLARS

received from grantees, does grant, bargain, sell convey and confirm unto Robin E. Elstermeier and Janet L. Elstermeier, husband and wife,

as joint tenants with right of survivorship, and not as tenants in common, the following described real property in Howard County, Nebraska:

Lots Five (5), Six (6), Seven (7), and Eight (8), in Block Eighty-two (82), Original Town of St. Paul, Nebraska.

STATE OF NEBRASKA HOWARD COUNTY, NE. # 456 FILED FOR RECORD MO. June DAY 6 1978 AT 1:30 O'CLOCK P.M. RECORDED IN BOOK 46 OF Deed PAGE 512

CHG. 6.25 PAB. FEE BOOK NUMERICAL INDEX GENERAL INDEX PICTURE

NEBRASKA DOCUMENTARY STAMP TAX JUN 6 1978 \$ 5.50 BY

To have and to hold the above described premises together with all tenements, hereditaments and appurtenances thereto belonging unto the grantees and to their assigns, or to the heirs and assigns of the survivor of them forever.

And grantor does hereby covenant with the grantees and with their assigns and with the heirs and assigns of the survivor of them that grantor is lawfully seized of said premises; that they are free from encumbrance

that grantor has good right and lawful authority to convey the same; and that grantor warrants and will defend the title to said premises against the lawful claims of all persons whomsoever.

It is the intention of all parties hereto that in the event of the death of either of the grantees, the entire fee title to this real property shall vest in the surviving grantee.

Dated May 25, 19 78. Gladys Schack (Gladys Schack) Garnet Schack (Garnet Schack) Jennie Johnson (Jennie Johnson) Harold E. Sorensen (Harold E. Sorensen)

STATE OF NEBRASKA County of HOWARD ss.

Before me, a notary public qualified for said county, personally came Gladys Schack, a single person, and Garnet Schack, a single person,

known to me to be the identical person or persons who signed the foregoing instrument and acknowledged the execution thereof to be his, her or their voluntary act and deed.

Witness my hand and notarial seal on May 25, 19 78.

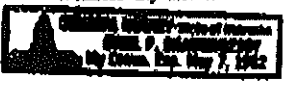

[Signature] Notary Public My commission expires May 7, 19 82.

STATE OF NEBRASKA)
) SS.
County of Lancaster)

Before me, a Notary Public qualified for said County, personally came Grace Sorensen and Harold E. Sorensen, wife and husband, each in her and his own right, and as spouse of the other, known to me to be the identical persons who signed the foregoing instrument and acknowledged the execution thereof to be their voluntary act and deed.

Witness my hand and Notarial Seal on *May 26*, 1978.

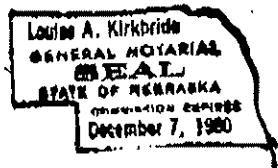

Louise A. Kirkbride
Notary Public.

My commission expires: *December 7, 1980*

STATE OF WYOMING)
) SS.
County of Albany)

Before me, a Notary Public qualified for said County, personally came Jennie Johnson, a widow and now a single person, known to me to be the identical person who signed the foregoing instrument and acknowledged the execution thereof to be her voluntary act and deed.

Witness my hand and Notarial Seal on *May 31*, 1978.

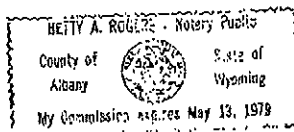

Betty A. Rogers
Notary Public.

My commission expires:

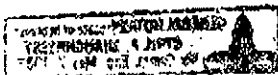

Marcus Paizosa & Michael Coghlan

2019 NSA/POAN NEBRASKA LAW ENFORCEMENT CONFERENCE

OCTOBER 6-9, 2019 - KEARNEY, NE - ATTENDEE BROCHURE
VALUABLE TRAINING FOR ALL LAW ENFORCEMENT PROFESSIONALS

Connect with law enforcement professionals across the state at the 2019 NSA/POAN Conference on October 6-9, 2019 in Kearney, NE!

The 2019 NSA/POAN Nebraska Law Enforcement Conference is once again the place to be for professionals involved in law enforcement. The convention will feature educational sessions requested by law enforcement professionals that will draw members from across the state.

For four days this fall, professionals from across the state will come together in Kearney to take advantage of leading educational programming and an exhibit hall offering tools, ideas, and products applicable to their everyday work lives.

Be sure to mark October 6-9, 2019, on your calendar now. The deadline for early registration is August 31, so take a few minutes today to complete the registration form in this brochure. We look forward to seeing you in Kearney!

HOTEL INFORMATION

Several room blocks are dedicated to conference attendees. *Room reservations must be made by August 30, 2019.* Please indicate you are with the Nebraska Law Enforcement conference. **Conference Location:** Younes Conference Center 416 W Talmadge Road Kearney, NE 68845.

FAIRFIELD INN & SUITES

510 West Talmadge Rd.
Kearney, NE 68845
(308) 236-4200
\$104.95 per room
\$139.95 per suite

LA QUINTA INN & SUITES

108 3rd Avenue
Kearney, NE 68845
(308)237-4400
\$97.95 per room
\$119.95 per suite

HOLIDAY INN

110 South 2nd Road
Kearney, NE 68845
(308)237-5971
\$104.95 per room
\$129.95 per suite

HAMPTON INN

507 West Talmadge Rd.
Kearney, NE 68845
(308)234-3400
\$104.95 per room

COMFORT INN

118 3rd Ave,
Kearney, NE 68847
(308) 236-3400
\$97.95 per room



THANKS TO OUR PLATINUM SPONSOR - NEVDRS
DISCOUNTED EARLY BIRD RATE AVAILABLE THANKS TO THEIR SPONSORSHIP.
SEE REGISTRATION FORM FOR MORE INFORMATION.

SUNDAY, OCTOBER 6

12:00-6:00 PM Open Registration
1:00-2:00 PM Nebraska Crime Commission Update
2:00-2:20 PM Fight Crime: Invest in Kids
– *Joshua Spaulding*
2:20-5:00 PM Human Trafficking - NSP
5:00-7:00 PM NSA Annual Meeting
5:00-7:00 PM POAN Board Meeting
7:00-11:00 PM Hospitality Room

MONDAY, OCTOBER 7

7:00-8:30 AM Open Registration
8:30-9:00 AM Opening Session
9:00-10:00 AM NeVDRS Speaker
9:00-1:00 PM Spouses Program– Corky Creations
(9-11 am) & Lunch-Angus)
10:00-10:30 AM Break in Vendor Area
10:30-12:00 PM National Missing & Unidentified Persons
System – *Melissa Gregory*
12:00-1:00 PM Lunch Provided in Vendor Area
1:05 PM Highway Safety Luncheon (invite only)
1:15-2:30 PM Afternoon Drawing in Classroom
2:30-3:00 PM The Kelsey Smith Case – *Greg Smith*
3:00-4:45 PM Break in Vendor Area
3:00-4:45 PM The Kelsey Smith Case continued – *Greg Smith*
5:30-7:30 PM President's Reception
7:30-11:00 PM Hospitality Room

TUESDAY, OCTOBER 8

8:00-10:00 AM The Bullet Proof Mind - *Col. Grossman*
10:00-10:30 AM Break in the Vendor Area
10:30-12:00 AM The Bullet Proof Mind – *Col. Grossman*
12:00-12:45 PM Lunch On Your Own
POAN Annual Luncheon
(POAN Members Only)
1:00-2:30 PM The Bullet Proof Mind – *Col. Grossman*
2:30-3:00 PM Break in Vendor Area
3:00-5:00 PM The Bullet Proof Mind – *Col. Grossman*
6:00-9:00 PM NSA & POAN Awards Banquet
Entertainment: Joe Cole
9:00-11:00 PM Hospitality Room

WEDNESDAY, OCTOBER 9

8:00-10:00 PM Why Teens Kill – *Chalmers*
10:00-10:30 AM Break in the Vendor Area
10:30-12:00 PM Why Teens Kill – *Chalmers*
12:00-12:15 PM Closing Comments
12:15-1:15 PM POAN Board Meeting

THREE WAYS TO REGISTER

1. FAX registration to 402.761.2224

2. EMAIL registration to
taylor@youraam.com

3. MAIL registration with check (checks must
be drawn on a U.S. bank in U.S. funds)

Registrations via telephone will
NOT be accepted.

VISIT OUR WEBSITE
www.nsapoan.com



ATTENDEE REGISTRATION

2019 NSA/POAN Conference - October 6-9, 2019

To register, complete the registration form & mail to NSA/POAN Conference Organizers, fax to 402.761.2224 or email taylor@youraam.com. Questions? Call (402)761-2216.

Name(s) _____ Credentials _____

Company _____

Address _____ City _____ ST _____ Zip _____

Daytime Phone () _____ Email _____

REGISTRATION OPTIONS	Before August 31	After August 31	Quantity	TOTAL
NSA or POAN Member Registration <i>Includes: Banquets and Lunches</i>	\$75.00*	\$125.00	_____	\$ _____
Non-Member Registration <i>Includes: Lunches</i>	\$95.00*	\$150.00	_____	\$ _____
Banquet Only	\$40.00	\$40.00	_____	\$ _____
Spouse Program <i>Includes: Corky Creations Canvas Fee and Lunch</i>	\$60.00	\$75.00	_____	\$ _____

*Discounted for 2019 due to NeVDRS sponsorship.

Check if you are a first time attendee to be entered into a drawing. TOTAL \$ _____

ADDITIONAL REGISTRANT NAMES AND CREDENTIALS (If different than listed above)

_____ I plan on attending the POAN Luncheon (Tuesday, October 8 - POAN Members only)

TOTAL ENCLOSED \$ _____ PLEASE SEND AN INVOICE

Please return registration form & payment to:
NSA/POAN Office, 521 First Street, Milford, NE 68405 or email to: taylor@youraam.com
CHECKS PAYABLE TO: NSA/POAN Conference

Cancellation Policy: A refund, less a \$25 administrative fee, will be given for all written requests postmarked by August 31, 2019. Requests received after that date will be reviewed by the NSA/POAN Conference Committee. In the unlikely event the 2019 Conference is cancelled due to uncontrollable circumstances, your payment will be considered a donation to the NSA/POAN Conference.

When you provide a check as payment, you authorize us either to use information from your check to make a one-time electronic fund transfer from your account or to process the payment as a check transaction. When we use information from your check to make an electronic fund transfer, funds may be withdrawn from your account as soon as the same day we receive your payment, and you will not receive your check back from your financial institution.

IMPORTANT DATES

EARLY BIRD REGISTRATION CUTOFF:
August 31, 2019

HOTEL ROOM BLOCK CUTOFF:
August 30, 2019

CONFERENCE DATES:
October 6-9, 2019

City Of St Paul Police

From: NSA/POAN Nebraska Law Enforcement Conference <taylor@youraam.com>
Sent: Tuesday, July 30, 2019 11:58 AM
To: City Of St Paul Police
Subject: Nebraska Joint Law Enforcement Conference - Attendee Registration Now Open!

Register Today!

[View this email in your browser](#)

**DON'T FORGET TO REGISTER FOR THE
NSA/POAN CONFERENCE
OCTOBER 6-9, 2019 - KEARNEY, NE**

Early-bird registration discounts end August 31st!



City of St. Paul
Receipts
July 2019

Aug. 8. 2019 3:01PM HOMESTEAD BANK

Date	From	Account	Description & Breakdown	Amount
7/3/2019	Wisconsin Physician Services	Ambulance	HCCLAIMPMT	1,097.22
7/3/2019	City Office		Rock Creek BBQ- Mobile Fd. Perm.	100.00
7/8/2019	TMCRDC5335	Ambulance	St. Paul Rescue Service	100.00
7/8/2019	City Office	Cemetery	Pheasants Forever - Ground Cons.	540.00
7/8/2019	Wisconsin Physician Services	Ambulance	HCCLAIMPMT	343.93
7/10/2019	State of Nebraska	Streets	July 2019 Highway Allocation	34,451.22
7/11/2019	BCBSNE	Ambulance	St. Paul Rescue Service	191.93
7/12/2019	Howard County Treasurer	V.P. Bond	Collections	3,799.93
7/12/2019	Howard County Treasurer		Collections	15,027.42
			General 2,329.91	
			Fire 501.19	
			Police 3,886.79	
			Cemetery 306.85	
			Pool 818.27	
			Park 920.55	
			Library 1,227.41	
			Senior Center 132.97	
			Civic Center 132.97	
			Streets - Motor Tax 4,228.43	
			Streets - Pro Rate 542.08	
7/12/2019	City Office	Library	St. Paul Public School - Reimb.	4,557.91
7/15/2019	TMCRDC5335	Ambulance	St. Paul Rescue Service	783.90
7/18/2019	BCBSNE	Ambulance	St. Paul Rescue Service	87.74
7/18/2019	City Office	V.P. Bond	Tommy Rene Printers payment	59.38
			Princ. 53.98, Int. 5.40	
7/18/2019	City Office	V.P. Bond	Goodenberger payments	65.00
			Water - Princ. 21.14, Int. 4.86	
			Sewer - Princ. 31.71, Int. 7.29	
7/22/2019	TMCRDC5335	Ambulance	St. Paul Rescue Service	587.82
7/23/2019	Wisconsin Physician Services	Ambulance	HCCLAIMPMT	111.68
7/25/2019	City Office	Recreation	After School Program - Grant	5,000.00
			from Miller Fund (HC Foundation)	

No. 1336 P. 1

City of St. Paul
Receipts
July 2019

7/26/2019	State of Nebraska		HHS - N.F.O.C.	385.00
7/26/2019	TMCRDC5335	Ambulance	St. Paul Rescue Service	826.70
7/31/2019	City Office	V.P. Bond	Dvoracek Title - Special Assess.	506.05
7/31/2019	Homestead Bank	General	Interest on checking for July	132.46
Other Accounts:				
7/1/2019	City Office - State of Nebraska - to Light 300-504-981 - North Yards Rent			250.00
7/1/2019	City Office - St. Paul Keno to Keno 300-504-409			3,932.55
7/3/2019	City Office - U-Betcha Auto payment to Sales Tax 300-504-420 Princ. 1,080.17, Int. 70.00			1,150.17
	City Office - Herv's Transmission payment to Sales Tax 300-504-420 Princ.			
7/3/2019	City Office - L & M Enterprises payment to Sales Tax 300-504-420 Princ. 1,737.58, Int. 195.44			1,933.02
7/3/2019	City Office- Augy's Fitness payment to Sales Tax 300-504-420 Princ. 657.104, Int. 92.96			750.00
7/3/2019	City Office - Summer Recreation Fees to Civic Center 300-300-749			90.00
7/3/2019	City Office - Summer Recreation Fees to Civic Center 300-300-749			18.00
7/8/2019	City Office - C. Hamilton payment to P.I. 300-504-684 Princ. 91.83, Int. 8.17			100.00
7/8/2019	Connie cashed TCD #1130259 at Heritage for \$150,463.16 and reinvested in TCD # 3212279 at Homestead			
7/9/2019	City Office - Howard County Medical Center to REDLG 300-301-465			5,000.00
7/9/2019	City Office - Summer Recreation Fees to Civic Center 300-300-749			18.00
7/11/2019	City Office - Summer Recreation Fees to Civic Center 300-300-749			70.00
7/12/2019	Howard County Treasurer - Excess TIF #8659 Prairie Falls to Project TIF 300-505-036			108.92
7/15/2009	City Office - Creative Hands payment to Sales Tax 300-504-420 Princ. 223.20, int. 76.80			300.00
7/17/2019	City Office - County Cage payment to Sales Tax 300-504-420 Princ. 434.44, Int. 140.56			575.00
7/18/2019	City Office - Northrup payment to Sales Tax 300-504-420 Princ. 193.79, Int. 20.21, Penalty 20.00			234.00
7/18/2019	City Office - Escape Tanning payment to Sales Tax 300-504-420 Princ. 143.20, Int. 16.80			160.00
7/18/2019	City Office - Starkey payment to P.I. 300-504-684 Water- Princ. 44.76, Int. 7.90			105.32
	Sewer - Princ. 44.75, Int. 7.91			
7/19/2019	Dora Johnson payment to Premium Investment 300-504-684 Princ. 71.40, Int. 28.60			100.00
7/19/2019	Bed Head payment to Sales Tax 300-504-420 Princ. 420.53, Int. 228.16			648.69
7/19/2019	City Office - Summer Recreation Fees to Civic Center 300-300-749			175.00
7/19/2019	City Office - Secure Storage payment to P.I. 300-504-684 Princ. 83.17, Int. 16.83			100.00
7/22/2019	State of NE - May City Sales Tax to Sales Tax 300-504-420			28,718.74
7/22/2019	Connie transferred \$3,645.98 from Sales Tax deposit above to checking 100-027 for streets			
7/29/2019	City Office - St. Paul Keno to Keno 300-504-409			5,056.17

City of St. Paul
Receipts
July 2019

7/31/2019	City Office - Housing Grant Savings 300041780 for month	50.00
7/31/2019	Homestead Bank - Interest on City Sales Tax Checking 300-300-277	3.94
7/31/2019	Homestead Bank - Interest on St. Paul Civic Center Checking 300-300-749	1.11
7/31/2019	Homestead Bank - Interest on City REDLG 300-301-465	16.03
7/31/2019	Homestead Bank - Interest on Water MMDA 300-504-189	9.18
7/31/2019	Homestead Bank - Interest on Keno MMDA 300-504-409	27.28
7/31/2019	Homestead Bank - Interest on Sales Tax P.I. 300-504-420	51.21
7/31/2019	Homestead Bank - Interest on Pool Construction MMDA 300-504-442	8.81
7/31/2019	Homestead Bank - Interest on Premium Investment 300-504-684	128.84
7/31/2019	Homestead Bank - Interest on General Equipment Sinking MMDA 300-504-805	8.92
7/31/2019	Homestead Bank - Interest on Sewer & Building Equipment Fund MMDA 300-504-849	26.97
7/31/2019	Homestead Bank - Interest on Police Equipment Fund MMDA 300-504-860	20.28
7/31/2019	Homestead Bank - Interest on Senior Center Fund MMDA 300-504-882	11.44
7/31/2019	Homestead Bank - Interest on Brick Account MMDA 300-504-915	0.27
7/31/2019	Homestead Bank - Interest on Library Maintenance Reserve MMDA 300-504-970	14.33
7/31/2019	Homestead Bank - Interest on Light Sinking Fund MMDA 300-504-981	6.56
7/31/2019	Homestead Bank - Interest on Fire Sinking Fund MMDA 300-504-992	5.27
7/31/2019	Homestead Bank - Interest on EMT Sinking Fund MMDA 300-505-003	12.29
7/31/2019	Homestead Bank - Interest on Street Sinking Fund MMDA 300-505-014	24.95
7/31/2019	Homestead Bank - Interest on Park Equipment Sinking Fund MMDA 300-505-025	14.09
7/31/2019	Homestead Bank - Interest on TIF Projects MMDA 300-505-036	0.13
7/31/2019	Homestead Bank - Interest on After School MMDA 300-505-146	0.43
7/31/2019	Homestead Bank - Interest on Civic Center Sinking Fund MMDA 300-505-179	2.85
7/24/2019	Homestead Bank - Sales Tax TCD #3327564	326.99
7/10/2019	Homestead Bank - General TCD #3051705	921.82
7/31/2019	Citizens Bank & Trust - Interest on Cafeteria 125 102407	2.47
7/31/2019	Citizens Bank & Trust - Interest on Health Deductible 102482	10.39
7/31/2019	Citizens Bank & Trust - Interest on Sales Tax Infrastructure 102342	48.92
7/31/2019	Citizens Bank & Trust - Interest on Light ICS MMA 103217	805.40
7/31/2019	Citizens Bank & Trust - Interest on ICS MMA 103225	165.28
7/31/2019	Citizens Bank & Trust - Interest on Sewer ICS MMA 103241	330.15
7/31/2019	Citizens Bank & Trust - Interest on General ICS MMA 103209	607.12
7/31/2019	Citizens Bank & Trust - Interest on Building Sinking ICS MMA 103233	104.20

City of St. Paul
Receipts
July 2019

7/31/2019	Citizens Bank & Trust - Interest on Firemen ICS MMA 103268		259.94
7/31/2019	Citizens Bank & Trust - Interest on Ambulance ICS MMA 103276		483.78
7/31/2019	Citizens Bank & Trust - Interest on Park ICS MMA 103824		152.77
7/31/2019	Citizens Bank & Trust - Interest on Police ICS MMA 103292		44.73
7/31/2019	Citizens Bank & Trust - Interest on Keno ICS MMA 103314		143.14
7/31/2019	Heritage Bank - Interest on ACH MMDA 411025		252.09
7/31/2019	Heritage Bank - Interest on Investors P.I. 4100744		43.53
7/7/2019	Heritage Bank - Interest on General TCD 1130259 (cashed 7/7/19)		566.96

City of St. Paul - Certificates of Deposit

Dept. Fund

07/30/2019

(All CD's are automatically renewable)

BANK	CD #	MATURITY DATE	AMOUNT	TERM	CURRENT RATE	INTEREST
General (Homestead)	3212279	7/8/24	\$150,463.16	60 Months	2.90%	Compound Qtrly
General (Citizens)	109366	11/15/23	\$56,254.00	60 Months	3.20%	Mthly Compound
General (Citizens)	109367	11/15/23	\$56,243.85	60 Months	3.20%	Mthly Compound
General (Homestead)	3212199	2/2/22	\$39,430.24	60 Months	1.65%	Compound Qtrly
General (Homestead)	3051705	4/10/22	\$218,417.08	60 Months	1.70%	Compound Qtrly
		Total	\$520,808.33			
Light (Homestead)	3640996	5/15/22	\$43,413.42	60 Months	1.70%	Compound Qtrly
Light (Homestead)	3212195	2/22/22	\$40,986.71	60 Months	1.65%	Compound Qtrly
		Total	\$84,400.13			
Water (Homestead)	3212196	2/2/22	31129.15	60 Months	1.65%	Compound Qtrly
		Total	31129.15			

City of St. Paul - Certificates of Deposit

Dept. Fund

07/30/2019

(All CD's are automatically renewable)

Sewer (Homestead)	3212197	2/2/22	36317.35	60 Months	1.65%	Compound Qtrly
Sewer (Homestead)	3212198	2/2/22	\$36,317.35	60 Months	1.65%	Cmpound Qtrly
		Total	\$72,634.70			
Fire (Homestead)	3212200	2/2/22	\$23,865.68	60 Months	1.65%	Compound Qtrly
Ambulance (Homestead)	3212201	2/2/22	\$51,363.10	60 Months	1.65%	Compound Qtrly
Park (Homestead)	3212202	2/2/22	\$41,505.53	60 Months	1.65%	Compound Qtrly
Sale Tx (Homestead) 11302	3327564	4/24/22	\$78,862.55	60 Months	1.67%	Compound Qtrly
Totals			\$904,569.17			

Daily Pool Receipts

Date: 8/10/19

Family: $\$110.00 + 7.15 = \117.15
Daily: $\$4.00 + .26 = \4.26
Individual: $\$55.00 + 3.58 = \58.58

Admissions

	# Sold	Cost	Tax	Total
Family Season Pass	<u> </u>	<u> </u>	<u> </u>	<u> </u>
Daily Ticket	<u>51</u>	<u>204.00</u>	<u>13.26</u>	<u>217.26</u>
Individual Season Pass	<u> </u>	<u> </u>	<u> </u>	<u> </u>
Total		<u>204.00</u>	<u>13.26</u>	<u>217.26</u>

Swim Lessons (non taxable): 30 pool party

Concessions: 31.52
Tax: 2.05
Total: 33.57

Total Taxes: $13.26 + 2.05 = \$15.31$

Total Deposit: $\$280.83$

Total on Register Tape: $217.26 + 30 + 33.57 = \$280.83$

Difference: 0

Notes: _____

CHECKS AND OTHER DEBITS ARE RECEIVED FOR DEPOSIT SUBJECT TO THE RULES AND REGULATIONS OF THIS BANK



HomesteadBank
your journey, your bank.

Date 8/12/19

* 300100027 ACCT. NO.

Name City of St. Paul

Address Pool Receipts - 8/10/19
DEPOSITS MAY NOT BE AVAILABLE FOR IMMEDIATE WITHDRAWAL

Sign For _____
Cash Back _____

DESCRIPTION	DOLLARS	CENTS
CURRENCY	247.00	
COIN		4.01
CHECKS	29.82	
TOTAL FROM OTHER SIDE		
LESS CASH RECEIVED		
TOTAL DEPOSIT	\$	280.83

⑆5555⑆0120⑆

.42

41-031	Admissions	204.00
41-582	Lessons	30.00
41-581	Concessions	31.52
41-700	Sales tax	15.31
		<hr/>
		\$ 280.83