

Committee of the Whole  
Monday, March 18, 2024 4:30 PM  
Columbus Community Building/Community Room  
2500 14 Street  
Columbus, NE 68601

The Mayor and City Council reserve the right to go into closed session as per Section 84-1410 of the Nebraska Revised Statutes. A current agenda is on file at City Hall, 2500 14 Street, Columbus, Nebraska. For more information, call 402-562-4224 or visit our website at [www.columbusne.us](http://www.columbusne.us).

{{Name: Agenda Item Name}}

- 1. Statement of compliance with Open Meetings Act and roll call.**

---

**NEBRASKA OPEN MEETINGS ACT**

---

**84-1407. Act, how cited.**

Sections 84-1407 to 84-1414 shall be known and may be cited as the Open Meetings Act.

**Source:** Laws 2004, LB 821, § 34.

**84-1408. Declaration of intent; meetings open to public.**

It is hereby declared to be the policy of this state that the formation of public policy is public business and may not be conducted in secret.

Every meeting of a public body shall be open to the public in order that citizens may exercise their democratic privilege of attending and speaking at meetings of public bodies, except as otherwise provided by the Constitution of Nebraska, federal statutes, and the Open Meetings Act.

**Source:** Laws 1975, LB 325, § 1; Laws 1996, LB 900, § 1071; Laws 2004, LB 821, § 35.

**Annotations**

- Nebraska's public meetings laws do not apply to school board deliberations pertaining solely to disputed adjudicative facts. *McQuinn v. Douglas Cty. Sch. Dist. No. 66*, 259 Neb. 720, 612 N.W.2d 198 (2000).
- The primary purpose of the public meetings law is to ensure that public policy is formulated at open meetings. *Marks v. Judicial Nominating Comm.*, 236 Neb. 429, 461 N.W.2d 551 (1990).
- The public meetings law is broadly interpreted and liberally construed to obtain the objective of openness in favor of the public, and provisions permitting closed sessions must be narrowly and strictly construed. *Grein v. Board of Education of Fremont*, 216 Neb. 158, 343 N.W.2d 718 (1984).
- Although a committee was a subcommittee of a natural resources district board, it was not subject to the Open Meetings Act because there was never a quorum of board members in attendance and the committee did not hold hearings, make policy, or take formal action on behalf of the board. *Koch v. Lower Loup NRD*, 27 Neb. App. 301, 931 N.W.2d 160 (2019).
- A county board of equalization is a public body whose meetings shall be open to the public. *Wolf v. Grubbs*, 17 Neb. App. 292, 759 N.W.2d 499 (2009).

**84-1409. Terms, defined.**

For purposes of the Open Meetings Act, unless the context otherwise requires:

(1)(a) Public body means (i) governing bodies of all political subdivisions of the State of Nebraska, (ii) governing bodies of all agencies, created by the Constitution of Nebraska, statute, or otherwise pursuant to law, of the executive department of the State of Nebraska, (iii) all independent boards, commissions, bureaus, committees, councils, subunits, or any other bodies created by the Constitution of Nebraska, statute, or otherwise pursuant to law, (iv) all study or advisory committees of the executive department of the State of Nebraska whether having continuing existence or appointed as special committees with limited existence, (v) advisory committees of the bodies referred to in subdivisions (i), (ii), and (iii) of this subdivision, and (vi) instrumentalities exercising essentially public functions; and

(b) Public body does not include (i) subcommittees of such bodies unless a quorum of the public body attends a subcommittee meeting or unless such subcommittees are holding hearings, making policy, or taking formal action on behalf of their parent body, except that all meetings of any subcommittee established under section 81-15,175 are subject to the Open Meetings Act, (ii) entities conducting judicial proceedings unless a court or other judicial body is exercising rulemaking authority, deliberating, or deciding upon the issuance of administrative orders, and (iii) the Judicial Resources Commission or subcommittees or subgroups of the commission;

(2) Meeting means all regular, special, or called meetings, formal or informal, of any public body for the purposes of briefing, discussion of public business, formation of tentative policy, or the taking of any action of the public body; and

(3) Virtual conferencing means conducting or participating in a meeting electronically or telephonically with interaction among the participants subject to subsection (2) of section 84-1412.

**Source:** Laws 1975, LB 325, § 2; Laws 1983, LB 43, § 1; Laws 1989, LB 429, § 42; Laws 1989, LB 311, § 14; Laws 1992, LB 1019, § 124; Laws 1993, LB 635, § 1; Laws 1996, LB 1044, § 978; Laws 1997, LB 798, § 37; Laws 2004, LB 821, § 36; Laws 2007, LB296, § 810; Laws 2011, LB366, § 2; Laws 2021, LB83, § 11; Laws 2022, LB922, § 12.

**Operative Date: July 21, 2022**

**Annotations**

- A township is a political subdivision, and as such, a township board is subject to the provisions of the public meetings laws. *Steenblock v. Elkhorn Township Bd.*, 245 Neb. 722, 515 N.W.2d 128 (1994).
- A county agricultural society is a public body to which the provisions of the Nebraska public meetings law are applicable. *Nixon v. Madison Co. Ag. Soc'y*, 217 Neb. 37, 348 N.W.2d 119 (1984).
- Failure by a public governing body, as defined under section 84-1409, R.R.S.1943, to take and record a roll call vote on an action, as required by section 84-1413(2), R.S.Supp.,1980, grants any citizen the right to sue for the purpose of

having the action declared void. In this case such failure could not be later corrected by a nunc pro tunc order because there was no showing that a roll call vote on the disputed action was actually taken, and even if it was the record showed it was not recorded until over a year later. Sections 23-1301, R.R.S.1943, and 23-1302, R.R.S.1943, make it the duty of the county clerk to record proceedings of the board of county commissioners. *State ex rel. Schuler v. Dunbar*, 208 Neb. 69, 302 N.W.2d 674 (1981).

- Although a committee was a subcommittee of a natural resources district board, it was not subject to the Open Meetings Act because there was never a quorum of board members in attendance and the committee did not hold hearings, make policy, or take formal action on behalf of the board. *Koch v. Lower Loup NRD*, 27 Neb. App. 301, 931 N.W.2d 160 (2019).
- Although the Open Meetings Act does not define "subcommittee," a subcommittee is generally defined as a group within a committee to which the committee may refer business. *Koch v. Lower Loup NRD*, 27 Neb. App. 301, 931 N.W.2d 160 (2019).
- The Open Meetings Act does not require policymakers to remain ignorant of the issues they must decide until the moment the public is invited to comment on a proposed policy. By excluding nonquorum subgroups from the definition of a public body, the Legislature has balanced the public's need to be heard on matters of public policy with a practical accommodation for a public body's need for information to conduct business. *Koch v. Lower Loup NRD*, 27 Neb. App. 301, 931 N.W.2d 160 (2019).
- As an administrative agency of the county, a county board of equalization is a public body. *Wolf v. Grubbs*, 17 Neb. App. 292, 759 N.W.2d 499 (2009).
- The electors of a township at their annual meeting are a public body under the Open Meetings Act. *State ex rel. Newman v. Columbus Township Bd.*, 15 Neb. App. 656, 735 N.W.2d 399 (2007).
- The meeting at issue in this case was a "meeting" within the parameters of subsection (2) of this section because it involved the discussion of public business, the formation of tentative policy, or the taking of any action of the public power district. *Hansmeyer v. Nebraska Pub. Power Dist.*, 6 Neb. App. 889, 578 N.W.2d 476 (1998).
- Informational sessions in which the governmental body hears reports are briefings. *Johnson v. Nebraska Environmental Control Council*, 2 Neb. App. 263, 509 N.W.2d 21 (1993).

**84-1410. Closed session; when; purpose; reasons listed; procedure; right to challenge; prohibited acts; chance meetings, conventions, or workshops.**

(1) Any public body may hold a closed session by the affirmative vote of a majority of its voting members if a closed session is clearly necessary for the protection of the public interest or for the prevention of needless injury to the reputation of an individual and if such individual has not requested a public meeting. The subject matter and the reason necessitating the closed session shall be identified in the motion to close. Closed sessions may be held for, but shall not be limited to, such reasons as:

(a) Strategy sessions with respect to collective bargaining, real estate purchases, pending litigation, or litigation which is imminent as evidenced by communication of a claim or threat of litigation to or by the public body;

(b) Discussion regarding deployment of security personnel or devices;

(c) Investigative proceedings regarding allegations of criminal misconduct;

(d) Evaluation of the job performance of a person when necessary to prevent needless injury to the reputation of a person and if such person has not requested a public meeting;

(e) For the Community Trust created under section 81-1801.02, discussion regarding the amounts to be paid to individuals who have suffered from a tragedy of violence or natural disaster; or

(f) For public hospitals, governing board peer review activities, professional review activities, review and discussion of medical staff investigations or disciplinary actions, and any strategy session concerning transactional negotiations with any referral source that is required by federal law to be conducted at arms length.

Nothing in this section shall permit a closed meeting for discussion of the appointment or election of a new member to any public body.

(2) The vote to hold a closed session shall be taken in open session. The entire motion, the vote of each member on the question of holding a closed session, and the time when the closed session commenced and concluded shall be recorded in the minutes. If the motion to close passes, then the presiding officer immediately prior to the closed session shall restate on the record the limitation of the subject matter of the closed session. The public body holding such a closed session shall restrict its consideration of matters during the closed portions to only those purposes set forth in the motion to close as the reason for the closed session. The meeting shall be reconvened in open session before any formal action may be taken. For purposes of this section, formal action shall mean a collective decision or a collective commitment or promise to make a decision on any question, motion, proposal, resolution, order, or ordinance or formation of a position or policy but shall not include negotiating guidance given by members of the public body to legal counsel or other negotiators in closed sessions authorized under subdivision (1)(a) of this section.

(3) Any member of any public body shall have the right to challenge the continuation of a closed session if the member determines that the session has exceeded the reason stated in the original motion to hold a closed session or if the member contends that the closed session is neither clearly necessary for (a) the protection of the public interest or (b) the prevention of needless injury to the reputation of an individual. Such challenge shall be overruled only by a majority vote of the members of the public body. Such challenge and its disposition shall be recorded in the minutes.

(4) Nothing in this section shall be construed to require that any meeting be closed to the public. No person or public body shall fail to invite a portion of its members to a meeting, and no public body shall designate itself a subcommittee of the whole body for the purpose of circumventing the Open Meetings Act. No closed session, informal meeting, chance meeting, social gathering, email, fax, or other electronic communication shall be used for the purpose of circumventing the requirements of the act.

(5) The act does not apply to chance meetings or to attendance at or travel to conventions or workshops of members of a public body at which there is no meeting of the body then intentionally convened, if there is no vote or other action taken regarding any matter over which the public body has supervision, control, jurisdiction, or advisory power.

**Source:** Laws 1975, LB 325, § 3; Laws 1983, LB 43, § 2; Laws 1985, LB 117, § 1; Laws 1992, LB 1019, § 125; Laws 1994, LB 621, § 1; Laws 1996, LB 900, § 1072; Laws 2004, LB 821, § 37; Laws 2004, LB 1179, § 1; Laws 2006, LB 898, § 1; Laws 2011, LB390, § 29; Laws 2012, LB995, § 17.

**Annotations**

- There is no absolute discovery privilege for communications that occur during a closed session. *State ex rel. Upper Republican NRD v. District Judges*, 273 Neb. 148, 728 N.W.2d 275 (2007).
- If a person present at a meeting observes a public meetings law violation in the form of an improper closed session and fails to object, that person waives his or her right to object at a later date. *Wasikowski v. Nebraska Quality Jobs Bd.*, 264 Neb. 403, 648 N.W.2d 756 (2002).
- The public interest mentioned in this section is that shared by citizens in general and by the community at large concerning pecuniary or legal rights and liabilities. *Grein v. Board of Education*, 216 Neb. 158, 343 N.W.2d 718 (1984).
- Hearing in closed executive session was contrary to this section since there was no showing of necessity or reason under subdivision (1)(a), (b), or (c), but did not result in reversal of board decision. *Simonds v. Board of Examiners*, 213 Neb. 259, 329 N.W.2d 92 (1983).
- Negotiations for the purchase of land need not be conducted at an open meeting but the deliberations of a city council as to whether an offer to purchase real estate

should be made should take place in an open meeting. *Pokorny v. City of Schuyler*, 202 Neb. 334, 275 N.W.2d 281 (1979).

- Public meeting law was not violated where the Board of Regents of the University of Nebraska voted to hold a closed session to consider the university president's resignation, and also discussed the appointment of an interim president during such session. *Meyer v. Board of Regents*, 1 Neb. App. 893, 510 N.W.2d 450 (1993).

**84-1411. Meetings of public body; notice; method; contents; when available; right to modify; duties concerning notice; virtual conferencing authorized; requirements; emergency meeting without notice; appearance before public body.**

(1)(a) Each public body shall give reasonable advance publicized notice of the time and place of each meeting as provided in this subsection. Such notice shall be transmitted to all members of the public body and to the public.

(b)(i) Except as provided in subdivision (1)(b)(ii) of this section, in the case of a public body described in subdivision (1)(a)(i) of section 84-1409 or such body's advisory committee, such notice shall be published in a newspaper of general circulation within the public body's jurisdiction and, if available, on such newspaper's website.

(ii) In the case of the governing body of a city of the second class or village or such body's advisory committee, such notice shall be published by:

(A) Publication in a newspaper of general circulation within the public body's jurisdiction and, if available, on such newspaper's website; or

(B) Posting written notice in three conspicuous public places in such city or village. Such notice shall be posted in the same three places for each meeting.

(iii) In the case of a public body not described in subdivision (1)(b)(i) or (ii) of this section, such notice shall be given by a method designated by the public body.

(c) In addition to a method of notice required by subdivision (1)(b)(i) or (ii) of this section, such notice may also be provided by any other appropriate method designated by such public body or such advisory committee.

(d) Each public body shall record the methods and dates of such notice in its minutes.

(e) Such notice shall contain an agenda of subjects known at the time of the publicized notice or a statement that the agenda, which shall be kept continually current, shall be readily available for public inspection at the principal office of the public body during normal business hours. Agenda items shall be sufficiently descriptive to give the public reasonable notice of the matters to be considered at the meeting. Except for items of an emergency nature, the agenda shall not be altered later than (i) twenty-four hours before the scheduled commencement of the meeting or

(ii) forty-eight hours before the scheduled commencement of a meeting of a city council or village board scheduled outside the corporate limits of the municipality. The public body shall have the right to modify the agenda to include items of an emergency nature only at such public meeting.

(2)(a) The following entities may hold a meeting by means of virtual conferencing if the requirements of subdivision (2)(b) of this section are met:

(i) A state agency, state board, state commission, state council, or state committee, or an advisory committee of any such state entity;

(ii) An organization, including the governing body, created under the Interlocal Cooperation Act, the Joint Public Agency Act, or the Municipal Cooperative Financing Act;

(iii) The governing body of a public power district having a chartered territory of more than one county in this state;

(iv) The governing body of a public power and irrigation district having a chartered territory of more than one county in this state;

(v) An educational service unit;

(vi) The Educational Service Unit Coordinating Council;

(vii) An organization, including the governing body, of a risk management pool or its advisory committees organized in accordance with the Intergovernmental Risk Management Act;

(viii) A community college board of governors;

(ix) The Nebraska Brand Committee;

(x) A local public health department;

(xi) A metropolitan utilities district;

(xii) A regional metropolitan transit authority; and

(xiii) A natural resources district.

(b) The requirements for holding a meeting by means of virtual conferencing are as follows:

(i) Reasonable advance publicized notice is given as provided in subsection (1) of this section, including providing access to a dial-in number or link to the virtual conference;

(ii) In addition to the public's right to participate by virtual conferencing, reasonable arrangements are made to accommodate the public's right to attend at a physical site and participate as provided in section 84-1412, including reasonable seating, in at least one designated site in a building open to the public and identified in the notice, with: At least one member of the entity holding such meeting, or his or her designee, present at each site; a

recording of the hearing by audio or visual recording devices; and a reasonable opportunity for input, such as public comment or questions, is provided to at least the same extent as would be provided if virtual conferencing was not used;

(iii) At least one copy of all documents being considered at the meeting is available at any physical site open to the public where individuals may attend the virtual conference. The public body shall also provide links to an electronic copy of the agenda, all documents being considered at the meeting, and the current version of the Open Meetings Act; and

(iv) Except as otherwise provided in this subdivision or subsection (4) of section 79-2204, no more than one-half of the meetings of the state entities, advisory committees, boards, councils, organizations, or governing bodies are held by virtual conferencing in a calendar year. In the case of an organization created under the Interlocal Cooperation Act that sells electricity or natural gas at wholesale on a multistate basis or an organization created under the Municipal Cooperative Financing Act, the organization may hold more than one-half of its meetings by virtual conferencing if such organization holds at least one meeting each calendar year that is not by virtual conferencing. The governing body of a risk management pool that meets at least quarterly and the advisory committees of the governing body may each hold more than one-half of its meetings by virtual conferencing if the governing body's quarterly meetings are not held by virtual conferencing.

(3) Virtual conferencing, emails, faxes, or other electronic communication shall not be used to circumvent any of the public government purposes established in the Open Meetings Act.

(4) The secretary or other designee of each public body shall maintain a list of the news media requesting notification of meetings and shall make reasonable efforts to provide advance notification to them of the time and place of each meeting and the subjects to be discussed at that meeting.

(5) When it is necessary to hold an emergency meeting without reasonable advance public notice, the nature of the emergency shall be stated in the minutes and any formal action taken in such meeting shall pertain only to the emergency. Such emergency meetings may be held by virtual conferencing. The provisions of subsection (4) of this section shall be complied with in conducting emergency meetings. Complete minutes of such emergency meetings specifying the nature of the emergency and any formal action taken at the meeting shall be made available to the public by no later than the end of the next regular business day.

(6) A public body may allow a member of the public or any other witness to appear before the public body by means of virtual conferencing.

(7)(a) Notwithstanding subsections (2) and (5) of this section, if an emergency is declared by the Governor pursuant to the Emergency Management Act as defined in section 81-829.39, a public body the territorial jurisdiction of which is included in the emergency declaration, in whole or in part, may hold a meeting by virtual conferencing during such emergency if the

public body gives reasonable advance publicized notice as described in subsection (1) of this section. The notice shall include information regarding access for the public and news media. In addition to any formal action taken pertaining to the emergency, the public body may hold such meeting for the purpose of briefing, discussion of public business, formation of tentative policy, or the taking of any action by the public body.

(b) The public body shall provide access by providing a dial-in number or a link to the virtual conference. The public body shall also provide links to an electronic copy of the agenda, all documents being considered at the meeting, and the current version of the Open Meetings Act. Reasonable arrangements shall be made to accommodate the public's right to hear and speak at the meeting and record the meeting. Subsection (4) of this section shall be complied with in conducting such meetings.

(c) The nature of the emergency shall be stated in the minutes. Complete minutes of such meeting specifying the nature of the emergency and any formal action taken at the meeting shall be made available for inspection as provided in subsection (5) of section 84-1413.

(8) In addition to any other statutory authorization for virtual conferencing, any public body not listed in subdivision (2)(a) of this section may hold a meeting by virtual conferencing if:

(a) The purpose of the virtual meeting is to discuss items that are scheduled to be discussed or acted upon at a subsequent non-virtual open meeting of the public body;

(b) No action is taken by the public body at the virtual meeting; and

(c) The public body complies with subdivisions (2)(b)(i) and (2)(b)(ii) of this section.

**Source:** Laws 1975, LB 325, § 4; Laws 1983, LB 43, § 3; Laws 1987, LB 663, § 25; Laws 1993, LB 635, § 2; Laws 1996, LB 469, § 6; Laws 1996, LB 1161, § 1; Laws 1999, LB 47, § 2; Laws 1999, LB 87, § 100; Laws 1999, LB 461, § 1; Laws 2000, LB 968, § 85; Laws 2004, LB 821, § 38; Laws 2004, LB 1179, § 2; Laws 2006, LB 898, § 2; Laws 2007, LB199, § 9; Laws 2009, LB361, § 2; Laws 2012, LB735, § 1; Laws 2013, LB510, § 1; Laws 2017, LB318, § 1; Laws 2019, LB212, § 5; Laws 2020, LB148, § 3; Laws 2021, LB83, § 12; Laws 2022, LB742, § 1; Laws 2022, LB908, § 1; Laws 2022, LB922, § 13.

**Note:** The Revisor of Statutes has pursuant to section 49-769 correlated LB742, section 1, with LB908, section 1, and LB922, section 13, to reflect all amendments.

**Note:** Changes made by LB742 and LB908 became effective July 21, 2022. Changes made by LB922 became operative July 21, 2022.

#### **Cross References**

- **Intergovernmental Risk Management Act**, see section 44-4301.
- **Interlocal Cooperation Act**, see section 13-801.
- **Joint Public Agency Act**, see section 13-2501.

- **Municipal Cooperative Financing Act**, see section 18-2401.

#### **Annotations**

- Under subsection (1) of this section, the Legislature has imposed only two conditions on the public body's notification method of a public meeting: (1) It must give reasonable advance publicized notice of the time and place of each meeting and (2) it must be recorded in the public body's minutes. *City of Elkhorn v. City of Omaha*, 272 Neb. 867, 725 N.W.2d 792 (2007).
- An emergency is "(a)ny event or occasional combination of circumstances which calls for immediate action or remedy; pressing necessity; exigency; a sudden or unexpected happening; an unforeseen occurrence or condition." *Steenblock v. Elkhorn Township Bd.*, 245 Neb. 722, 515 N.W.2d 128 (1994).
- An agenda which gives reasonable notice of the matters to be considered at a meeting of a city council complies with the requirements of this section. *Pokorny v. City of Schuyler*, 202 Neb. 334, 275 N.W.2d 281 (1979).
- When notice is required, a notice of a special meeting of a city council posted in three public places at 10:00 p.m. on the day preceding the meeting is not reasonable advance publicized notice of a meeting as is required by this section. *Pokorny v. City of Schuyler*, 202 Neb. 334, 275 N.W.2d 281 (1979).
- Teacher waived right to object to lack of public notice in board of education employment hearing by voluntary participation in the hearing without objection. *Alexander v. School Dist. No. 17*, 197 Neb. 251, 248 N.W.2d 335 (1976).
- A county board of commissioners and a county board of equalization are not required to give separate notices when the notice states only the time and place that the boards meet and directs a citizen to where the agendas for each board can be found. *Wolf v. Grubbs*, 17 Neb. App. 292, 759 N.W.2d 499 (2009).
- A county board of equalization is a public body which is required to give advanced publicized notice of its meetings. *Wolf v. Grubbs*, 17 Neb. App. 292, 759 N.W.2d 499 (2009).
- Notice of recessed and reconvened meetings must be given in the same fashion as the original meeting. *Wolf v. Grubbs*, 17 Neb. App. 292, 759 N.W.2d 499 (2009).
- True notice of a meeting is not given by burying such in the minutes of a prior board proceeding. *Wolf v. Grubbs*, 17 Neb. App. 292, 759 N.W.2d 499 (2009).
- An agenda notice which merely stated "work order reports" was an inadequate notice under this section because it did not give interested persons knowledge that plans for a 345 kv transmission line through the district was going to be discussed and voted upon at the meeting. Inadequate agenda notice under this section meant there was a substantial violation of the public meeting laws; however, later actions by the board of directors cured the defects in notice, and such actions were in substantial compliance with the statute. *Hansmeyer v. Nebraska Pub. Power Dist.*, 6 Neb. App. 889, 578 N.W.2d 476 (1998).

**84-1412. Meetings of public body; rights of public; public body; powers and duties.**

(1) Subject to the Open Meetings Act, the public has the right to attend and the right to speak at meetings of public bodies, and all or any part of a meeting of a public body, except for closed sessions called pursuant to section 84-1410, may be videotaped, televised, photographed, broadcast, or recorded by any person in attendance by means of a tape recorder, a camera, video equipment, or any other means of pictorial or sonic reproduction or in writing.

(2) It shall not be a violation of subsection (1) of this section for any public body to make and enforce reasonable rules and regulations regarding the conduct of persons attending, speaking at, videotaping, televising, photographing, broadcasting, or recording its meetings, including meetings held by virtual conferencing. A body may not be required to allow citizens to speak at each meeting, but it may not forbid public participation at all meetings.

(3) No public body shall require members of the public to identify themselves as a condition for admission to the meeting nor shall such body require that the name of any member of the public be placed on the agenda prior to such meeting in order to speak about items on the agenda. The body shall require any member of the public desiring to address the body to identify himself or herself, including an address and the name of any organization represented by such person unless the address requirement is waived to protect the security of the individual.

(4) No public body shall, for the purpose of circumventing the Open Meetings Act, hold a meeting in a place known by the body to be too small to accommodate the anticipated audience.

(5) No public body shall be deemed in violation of this section if it holds its meeting in its traditional meeting place which is located in this state.

(6) No public body shall be deemed in violation of this section if it holds a meeting outside of this state if, but only if:

(a) A member entity of the public body is located outside of this state and the meeting is in that member's jurisdiction;

(b) All out-of-state locations identified in the notice are located within public buildings used by members of the entity or at a place which will accommodate the anticipated audience;

(c) Reasonable arrangements are made to accommodate the public's right to attend, hear, and speak at the meeting, including making virtual conferencing available at an in-state location to members, the public, or the press, if requested twenty-four hours in advance;

(d) No more than twenty-five percent of the public body's meetings in a calendar year are held out-of-state;

(e) Out-of-state meetings are not used to circumvent any of the public government purposes established in the Open Meetings Act; and

(f) The public body publishes notice of the out-of-state meeting at least twenty-one days before the date of the meeting in a legal newspaper of statewide circulation.

(7) Each public body shall, upon request, make a reasonable effort to accommodate the public's right to hear the discussion and testimony presented at a meeting.

(8) Public bodies shall make available at the meeting or the in-state location for virtual conferencing as required by subdivision (6)(c) of this section, for examination and copying by members of the public, at least one copy of all reproducible written material to be discussed at an open meeting, either in paper or electronic form. Public bodies shall make available at least one current copy of the Open Meetings Act posted in the meeting room at a location accessible to members of the public. At the beginning of the meeting, the public shall be informed about the location of the posted information.

**Source:** Laws 1975, LB 325, § 5; Laws 1983, LB 43, § 4; Laws 1985, LB 117, § 2; Laws 1987, LB 324, § 5; Laws 1996, LB 900, § 1073; Laws 2001, LB 250, § 2; Laws 2004, LB 821, § 39; Laws 2006, LB 898, § 3; Laws 2008, LB962, § 1; Laws 2021, LB83, § 13.

**Annotations**

- To preserve an objection that a public body failed to make documents available at a public meeting as required by subsection (8) of this section, a person who attends a public meeting must not only object to the violation, but must make that objection to the public body or to a member of the public body. *Stoetzel & Sons v. City of Hastings*, 265 Neb. 637, 658 N.W.2d 636 (2003).

**84-1413. Meetings; minutes; roll call vote; secret ballot; when; agenda and minutes; required on website; when.**

(1) Each public body shall keep minutes of all meetings showing the time, place, members present and absent, and the substance of all matters discussed.

(2) Any action taken on any question or motion duly moved and seconded shall be by roll call vote of the public body in open session, and the record shall state how each member voted or if the member was absent or not voting. The requirements of a roll call or viva voce vote shall be satisfied by a public body which utilizes an electronic voting device which allows the yeas and nays of each member of such public body to be readily seen by the public.

(3) The vote to elect leadership within a public body may be taken by secret ballot, but the total number of votes for each candidate shall be recorded in the minutes.

(4) The minutes of all meetings and evidence and documentation received or disclosed in open session shall be public records and open to public inspection during normal business hours.

(5) Minutes shall be written or kept as an electronic record and shall be available for inspection within ten working days or prior to the next convened meeting, whichever occurs

earlier, except that cities of the second class and villages may have an additional ten working days if the employee responsible for writing or keeping the minutes is absent due to a serious illness or emergency.

(6) Beginning July 31, 2022, the governing body of a natural resources district, the city council of a city of the metropolitan class, the city council of a city of the primary class, the city council of a city of the first class, the county board of a county with a population greater than twenty-five thousand inhabitants, and the school board of a school district shall make available on such entity's public website the agenda and minutes of any meeting of the governing body. The agenda shall be placed on the website at least twenty-four hours before the meeting of the governing body. Minutes shall be placed on the website at such time as the minutes are available for inspection as provided in subsection (5) of this section. This information shall be available on the public website for at least six months.

**Source:** Laws 1975, LB 325, § 6; Laws 1978, LB 609, § 3; Laws 1979, LB 86, § 9; Laws 1987, LB 663, § 26; Laws 2005, LB 501, § 1; Laws 2009, LB361, § 3; Laws 2015, LB365, § 2; Laws 2016, LB876, § 1; Laws 2021, LB83, § 14; Laws 2022, LB742, § 2.

**Effective Date: July 21, 2022**

**Annotations**

- If a person present at a meeting observes and fails to object to an alleged public meetings laws violation in the form of a failure to conduct rollcall votes before taking actions on questions or motions pending, that person waives his or her right to object at a later date. *Hauser v. Nebraska Police Stds. Adv. Council*, 264 Neb. 944, 653 N.W.2d 240 (2002).
- Subsection (2) of this section does not require the record to state that the vote was by roll call, but requires only that the record show if and how each member voted. Neither does the statute set a time limit for recording the results of a vote, after which no corrections of the record can be made. If no intervening rights of third persons have arisen, a board of county commissioners has power to correct the record of the proceedings had at a previous meeting so as to make them speak the truth, particularly where the correction supplies some omitted fact or action and is done not to contradict or change the original record but to have the record show that a certain action was taken or thing done, which the original record fails to show. *State ex rel. Schuler v. Dunbar*, 214 Neb. 85, 333 N.W.2d 652 (1983).
- Failure by a public governing body, as defined under section 84-1409, R.R.S.1943, to take and record a roll call vote on an action, as required by section 84-1413(2), R.S.Supp.,1980, grants any citizen the right to sue for the purpose of having the action declared void. In this case such failure could not be later corrected by a nunc pro tunc order because there was no showing that a roll call vote on the disputed action was actually taken, and even if it was the record showed it was not recorded until over a year later. Sections 23-1301, R.R.S.1943,

and 23-1302, R.R.S.1943, make it the duty of the county clerk to record proceedings of the board of county commissioners. *State ex rel. Schuler v. Dunbar*, 208 Neb. 69, 302 N.W.2d 674 (1981).

- There is no requirement that a public body make a record of where notice was published or posted. *Wolf v. Grubbs*, 17 Neb. App. 292, 759 N.W.2d 499 (2009).

**84-1414. Unlawful action by public body; declared void or voidable by district court; when; duty to enforce open meeting laws; citizen's suit; procedure; violations; penalties.**

(1) Any motion, resolution, rule, regulation, ordinance, or formal action of a public body made or taken in violation of the Open Meetings Act shall be declared void by the district court if the suit is commenced within one hundred twenty days of the meeting of the public body at which the alleged violation occurred. Any motion, resolution, rule, regulation, ordinance, or formal action of a public body made or taken in substantial violation of the Open Meetings Act shall be voidable by the district court if the suit is commenced more than one hundred twenty days after but within one year of the meeting of the public body in which the alleged violation occurred. A suit to void any final action shall be commenced within one year of the action.

(2) The Attorney General and the county attorney of the county in which the public body ordinarily meets shall enforce the Open Meetings Act.

(3) Any citizen of this state may commence a suit in the district court of the county in which the public body ordinarily meets or in which the plaintiff resides for the purpose of requiring compliance with or preventing violations of the Open Meetings Act, for the purpose of declaring an action of a public body void, or for the purpose of determining the applicability of the act to discussions or decisions of the public body. It shall not be a defense that the citizen attended the meeting and failed to object at such time. The court may order payment of reasonable attorney's fees and court costs to a successful plaintiff in a suit brought under this section.

(4) Any member of a public body who knowingly violates or conspires to violate or who attends or remains at a meeting knowing that the public body is in violation of any provision of the Open Meetings Act shall be guilty of a Class IV misdemeanor for a first offense and a Class III misdemeanor for a second or subsequent offense.

**Source:** Laws 1975, LB 325, § 9; Laws 1977, LB 39, § 318; Laws 1983, LB 43, § 5; Laws 1992, LB 1019, § 126; Laws 1994, LB 621, § 2; Laws 1996, LB 900, § 1074; Laws 2004, LB 821, § 40; Laws 2006, LB 898, § 4.

**Annotations**

- The Legislature has granted standing to a broad scope of its citizens for the very limited purpose of challenging meetings allegedly in violation of the Open Meetings Act, so that they may help police the public policy embodied by the act. *Schauer v. Grooms*, 280 Neb. 426, 786 N.W.2d 909 (2010).

- Any citizen of the state may commence an action to declare a public body's action void. *City of Elkhorn v. City of Omaha*, 272 Neb. 867, 725 N.W.2d 792 (2007).
- The reading of ordinances constitutes a formal action under subsection (1) of this section. *City of Elkhorn v. City of Omaha*, 272 Neb. 867, 725 N.W.2d 792 (2007).
- If a person present at a meeting observes a public meetings law violation in the form of an improper closed session and fails to object, that person waives his or her right to object at a later date. *Wasikowski v. Nebraska Quality Jobs Bd.*, 264 Neb. 403, 648 N.W.2d 756 (2002).
- Under the Public Meetings Act, a county lacks capacity to maintain an action to declare its official conduct "void" for noncompliance with the act. *County of York v. Johnson*, 230 Neb. 403, 432 N.W.2d 215 (1988).
- When a petitioner under this section is successful in the district court, that court may allow attorney fees. *Tracy Corp. II v. Nebraska Pub. Serv. Comm.*, 218 Neb. 900, 360 N.W.2d 485 (1984).
- Informal discussions between the Tax Commissioner and the State Board of Equalization in which instructions were clarified, with such clarification leading to the amendment of hearing notices, did not constitute a public meeting subject to the provisions of this section. *Box Butte County v. State Board of Equalization and Assessment*, 206 Neb. 696, 295 N.W.2d 670 (1980).
- The right to collaterally attack an order made in contravention of the Public Meeting Act must occur within a period of one year as is specifically provided by this section. *Witt v. School District No. 70*, 202 Neb. 63, 273 N.W.2d 669 (1979).
- Statutory change, requiring "publicized notice" for board of education employment hearings, occurring between dates meeting scheduled and conducted, held not to void proceedings. *Alexander v. School Dist. No. 17*, 197 Neb. 251, 248 N.W.2d 335 (1976).
- Voiding an entire meeting is a proper remedy for violations of the Open Meetings Act. Once a meeting has been declared void pursuant to Nebraska's public meetings law, board members are prohibited from considering any information obtained at the illegal meeting. *Wolf v. Grubbs*, 17 Neb. App. 292, 759 N.W.2d 499 (2009).
- Actions by the board of directors were merely voidable under this section, and not void. Pursuant to subsection (3) of this section, the plaintiffs were awarded partial attorney fees because they were successful in having the court declare that the board of directors was in substantial violation of the statute, even though the plaintiffs did not get the relief requested of having the board's actions declared void. *Hansmeyer v. Nebraska Pub. Power Dist.*, 6 Neb. App. 889, 578 N.W.2d 476 (1998).

--

Source: [http://nebraskalegislature.gov/laws/display\\_html.php?begin\\_section=84-1407&end\\_section=84-1414](http://nebraskalegislature.gov/laws/display_html.php?begin_section=84-1407&end_section=84-1414)

Date: July 2022

## **2. Water Master Plan**





# Water Master Plan



February 20, 2024

# Agenda

- A** Master Planning Overview
- B** Demand Projections
- C** System Evaluation
- D** Treatment Evaluation
- E** Improvements Overview
- F** Questions and Conversation



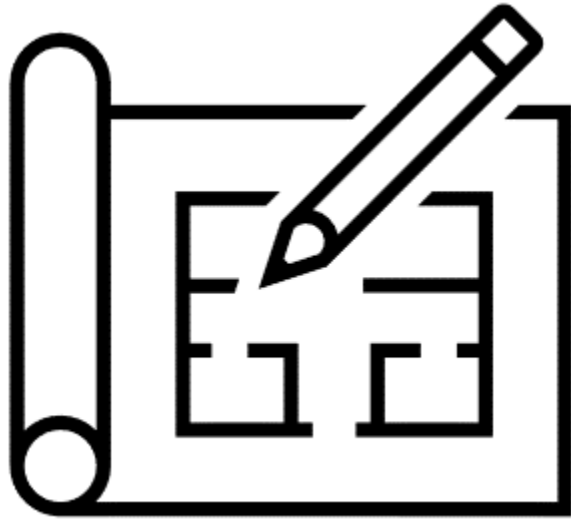

# Capital Improvement Planning Overview



# Water Master Plan Purpose:

- Detailed assessment of existing system – hydraulics and treatment
- Identification of projected future demands
- Development of strategies to address system challenges
- Development of an implementable, prioritized, and adaptable CIP



# Project Scope

## Water Demand Projections

- Develop future water demand based on population projections

## Water System Evaluation

- Develop a hydraulic model of the current system to identify deficiencies and needed improvements
- Model the system with future demand projections to identify anticipated improvements

## Treatment Evaluation

- Evaluate the existing water data and develop treatment options
- Evaluate well field expansion options
- Evaluate clearwell expansion options

## CIP Recommendations

- Develop budgetary estimates and timelines for recommend projects



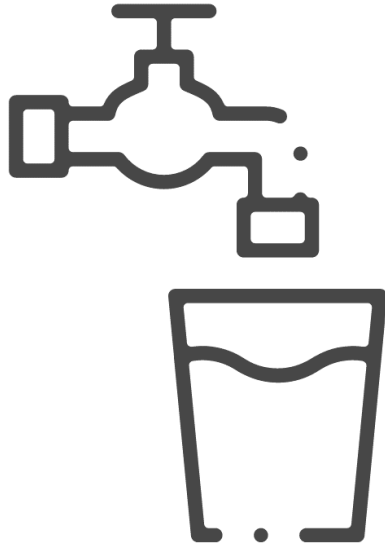

# Water Demand Projections



# Population Projection Overview

- Based on Envision Columbus 2040
- Columbus population rose steadily since 1960
- Based on 2020 census, current population is 24,028
- Multiple scenarios ran based on 2018 Comprehensive Plan
- 1% annual growth recommended as conservative estimate

Year	Projected Population, 1.0% Growth Rate
2020 (Existing)	24,028
2025	25,300
2030	26,600
2035	27,900
2040	29,300



# Estimating Future Populations

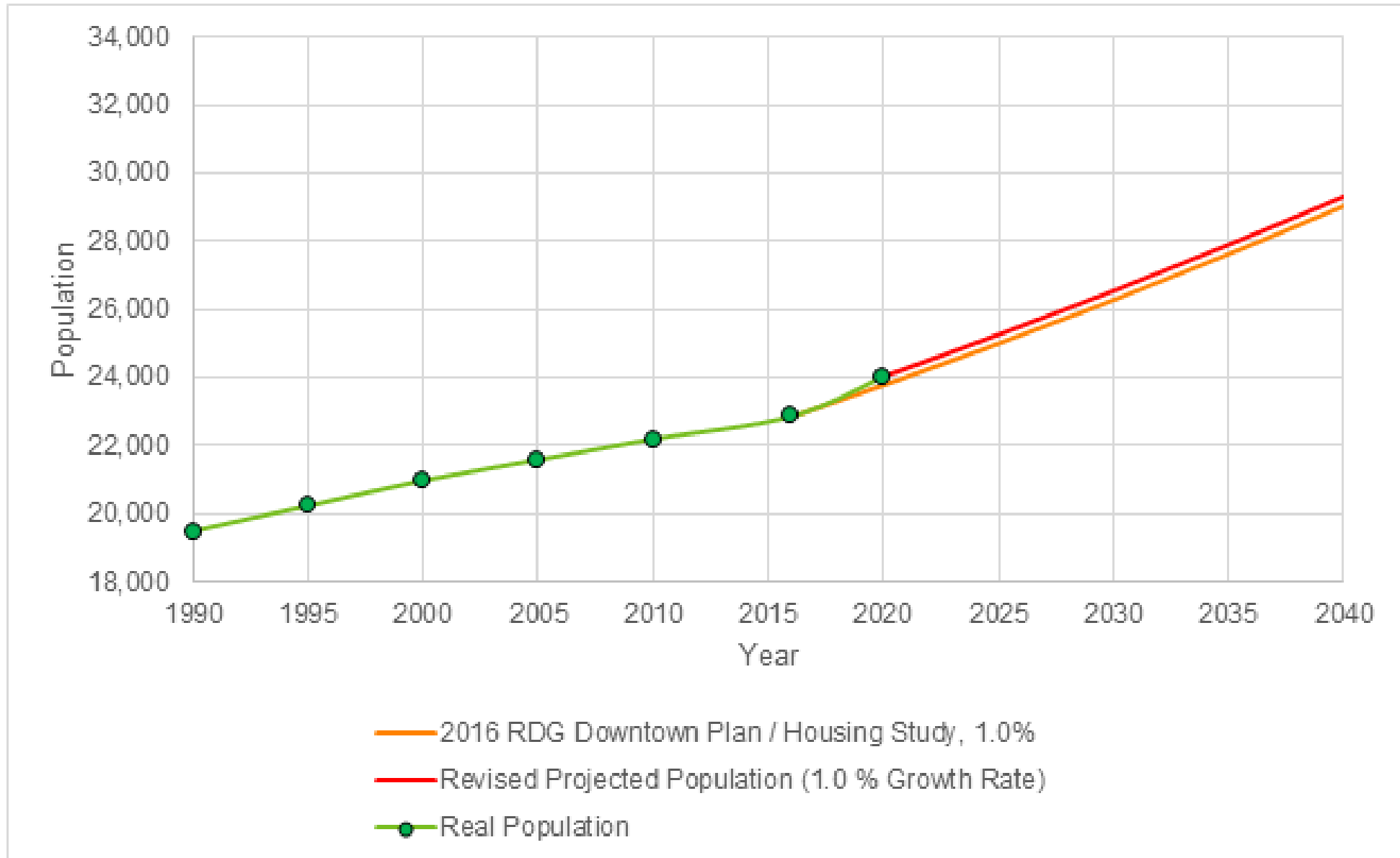



# Water System Evaluation and Optimization



# Columbus Water Distribution System

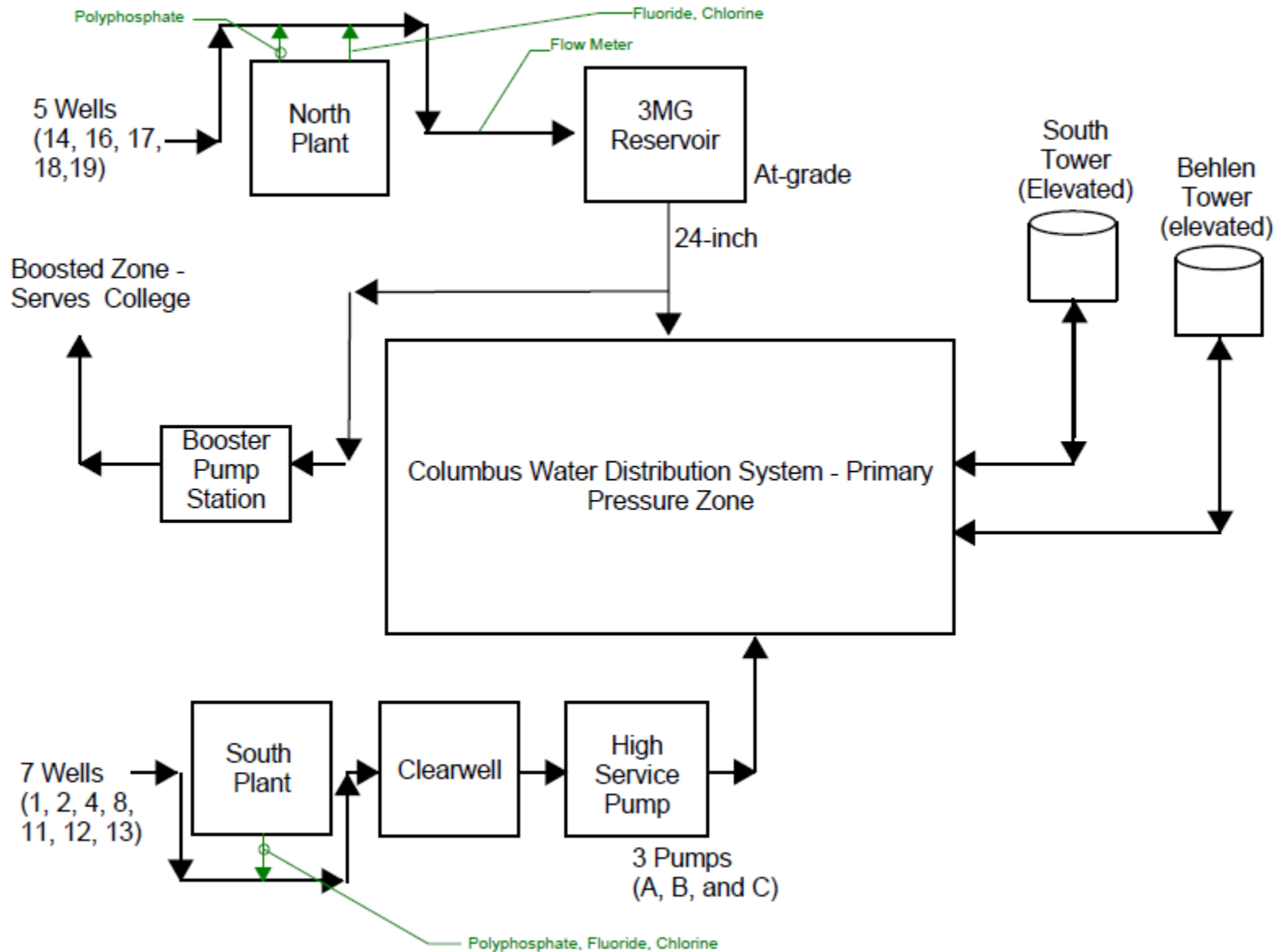

# Distribution System Evaluation

- Developed hydraulic model for the existing system
- Validated the model with flow tests
- Incorporated water use projections
- Evaluated near-term (2025), mid-term (2030), and long-term (2040)
  - Pressures
  - Velocities
  - Fire flows



# Columbus' Vision for 2040 – Projected Growth Areas

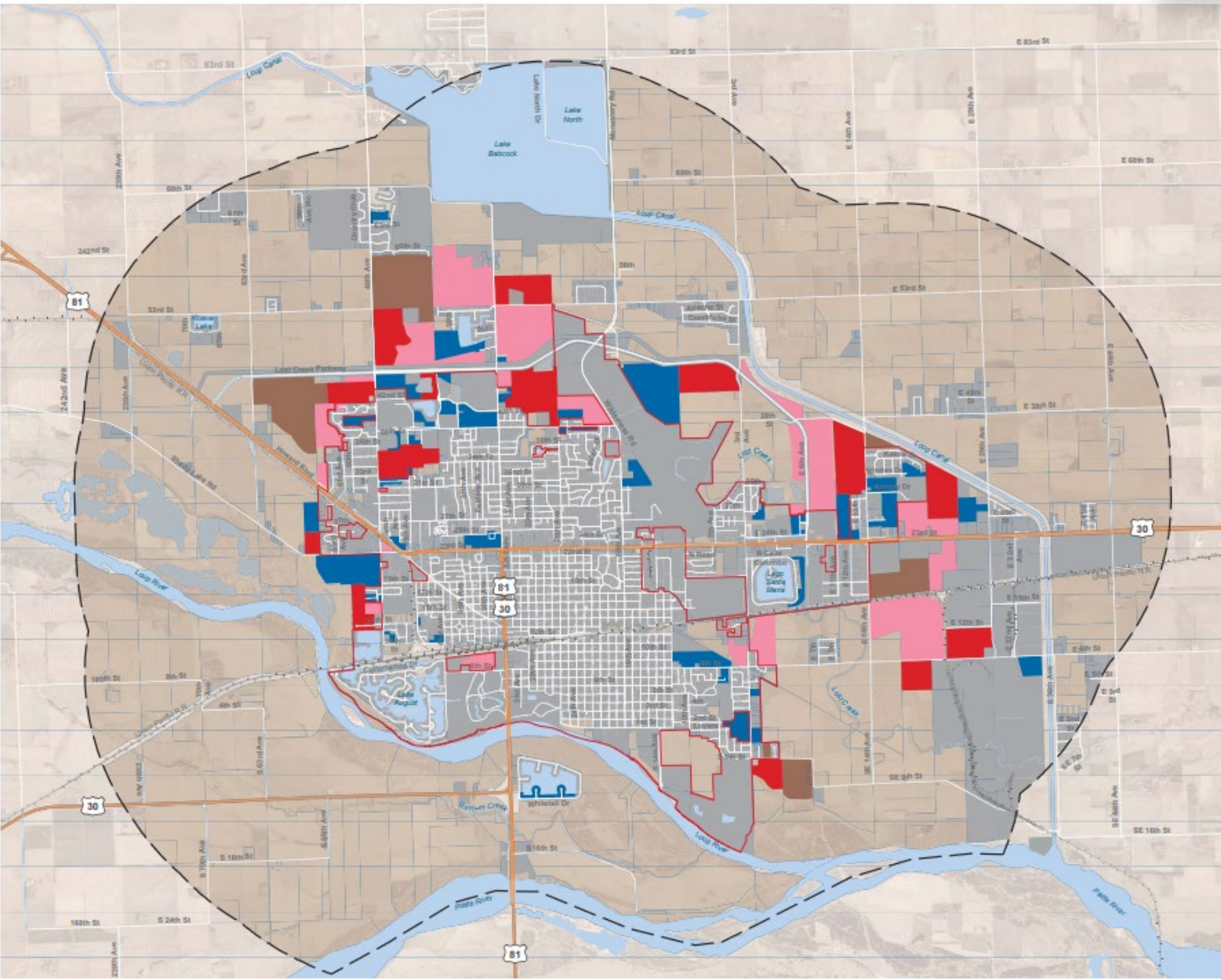

# Water Use Projections

- Average Daily Demand (ADD)
- Maximum Daily Demand (MDD)
- Projected demand based on projected 1% annual growth
- Recommended to plan for 14.8 MDD
  - Projections would be adjusted if large or unforeseen development materializes

Year	ADD (MGD)	MDD (MGD)
Existing	6.1	12.1
2025	6.4	12.8
2030	6.7	13.5
2035	7.1	14.1
2040	7.4	14.8



# Water Demand Projections

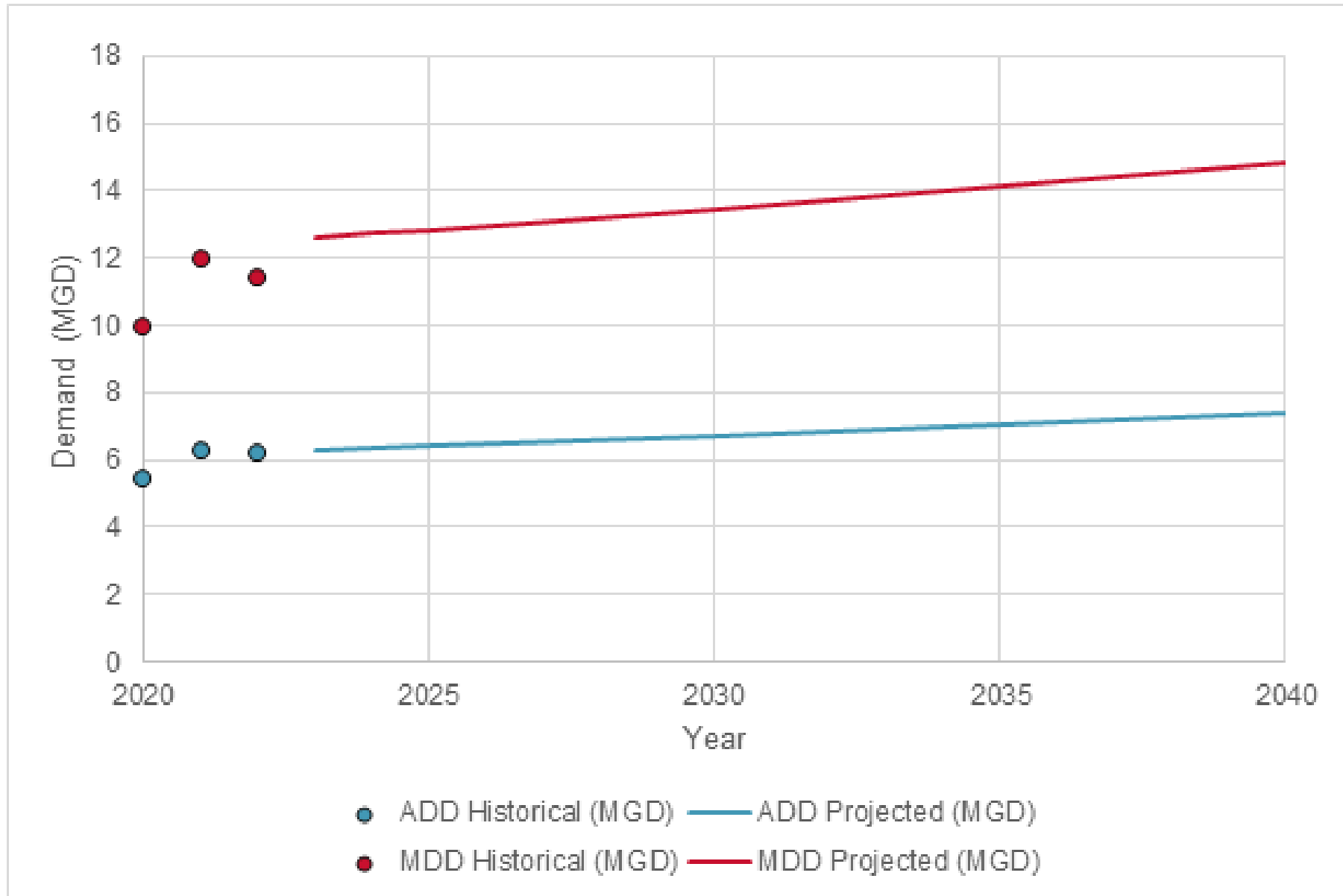

# 2040 Pressure Model Results with No Improvements

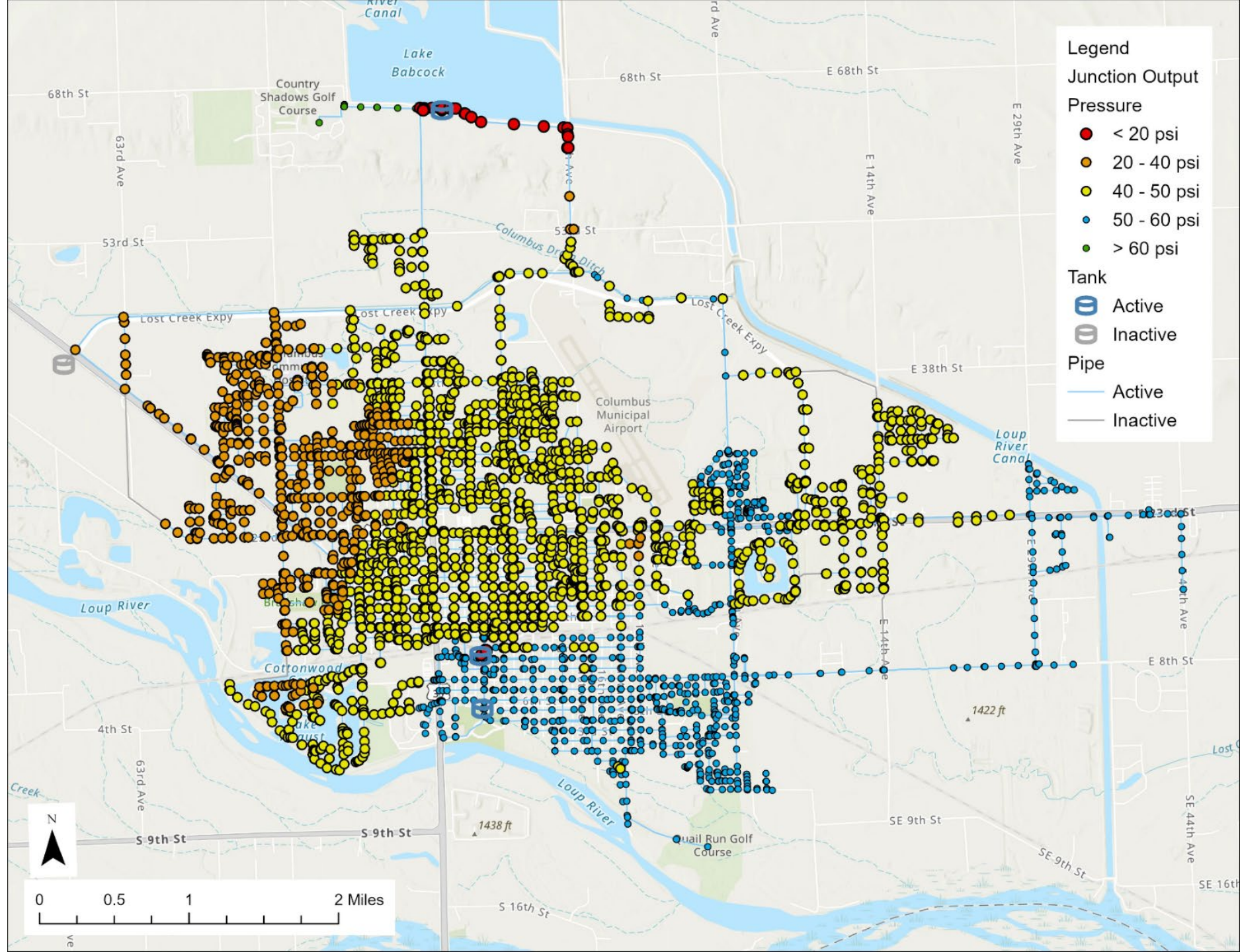

# 2040 Velocity Model Results with No Improvements

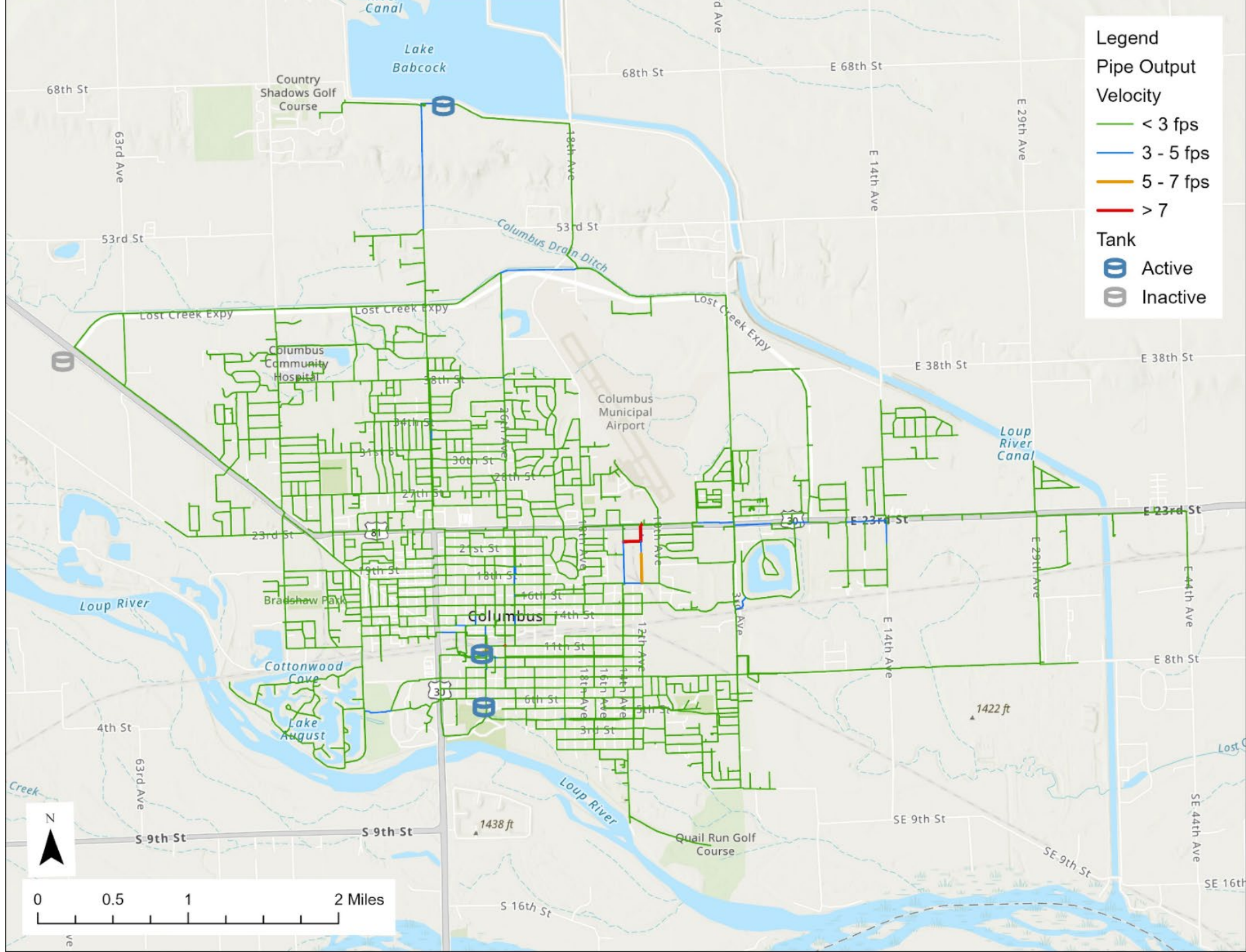

# 2040 Fire Flow Model Results with No Improvements

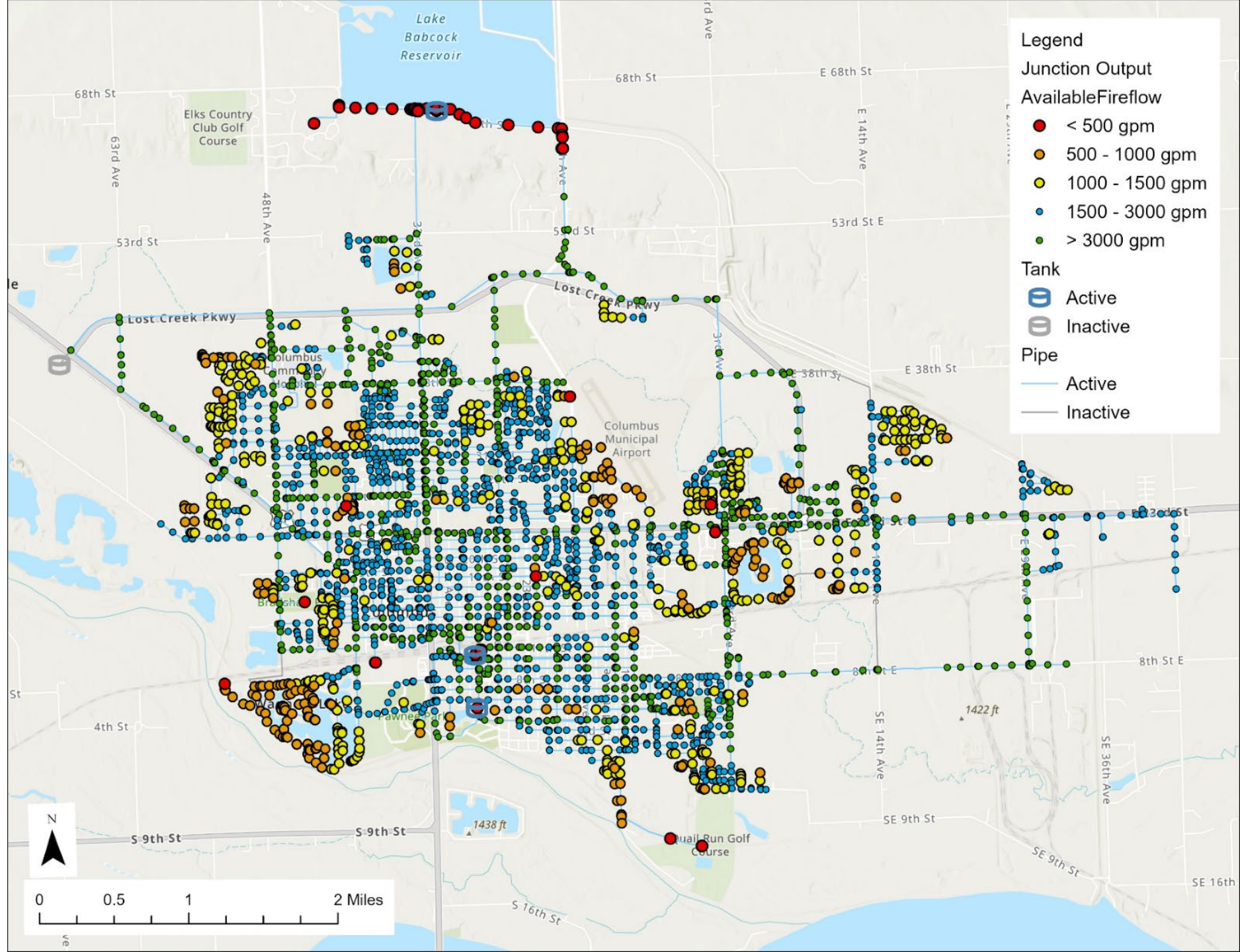



# 2040 Pressure Model with Proposed System Improvements

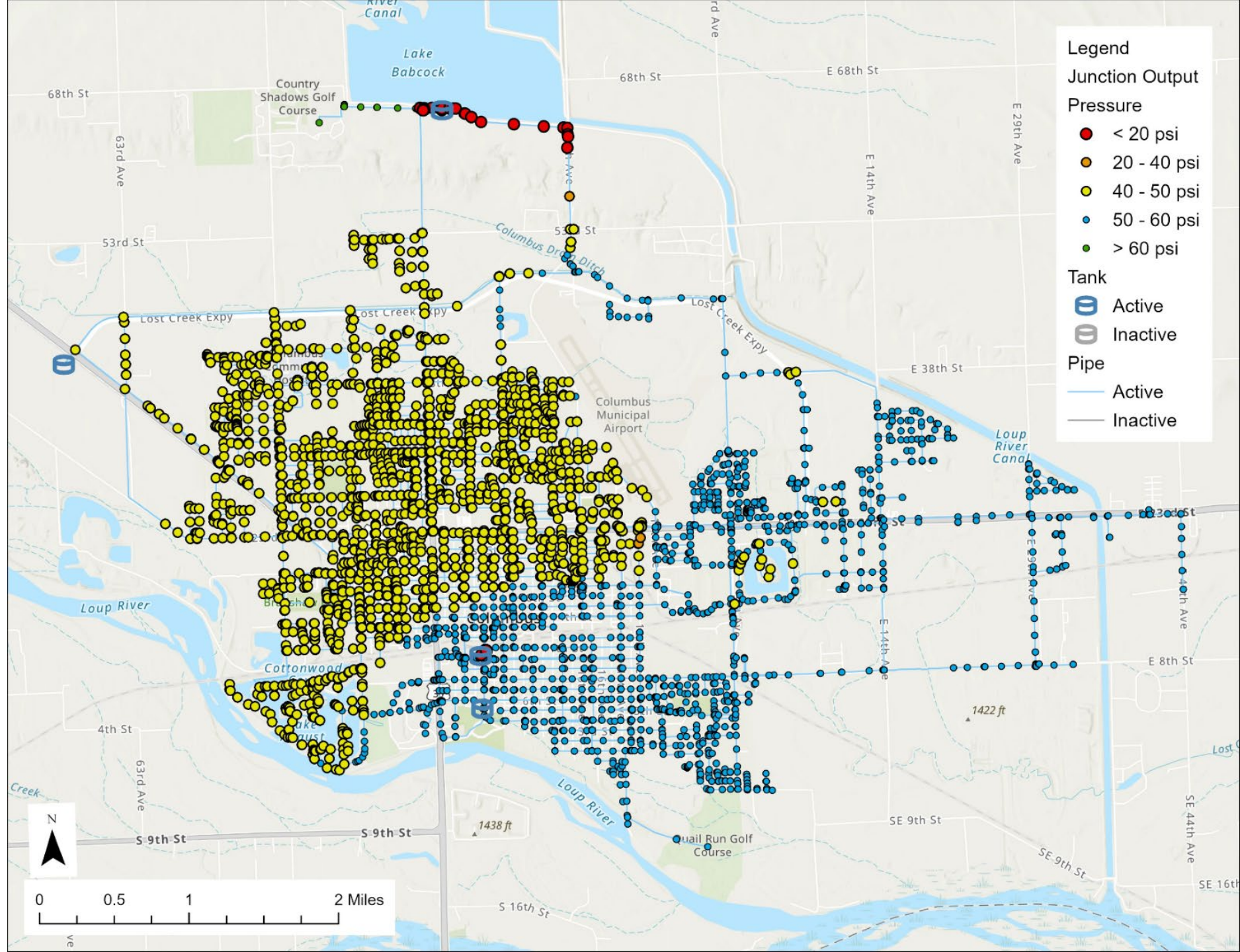

# Storage and Pump Station Evaluation

- Storage volume components: operational, fire flow, and reserve
- Existing system: South elevated tower and north reservoir
- Behlen tower not counted for operational or fire flow storage
- Incorporated water use projections
- Evaluated near-term (2025), mid-term (2030), and long-term (2040)



# Storage Evaluation

- Storage evaluation conducted using existing storage capacity and demands
- City currently has 2.6 MG of usable storage capacity.
- Current storage deficit: 0.9 MG
  - 2030 projected deficit: 1.4 MG
  - 2040 projected deficit: 1.7 MG

2040 Evaluation		Storage Required per Storage Criteria (MG)			
Storage Facility	Storage Capacity (MG)	Operational	Fire Flow	Total	Surplus/Deficit
South WTP Tower	2.00	3.2	1.0	4.2	<b>-1.7</b>
North WTP Reservoir	0.42				
Behlen	0				
<b>Total Usable Storage</b>	<b>2.42</b>				



# Storage Evaluation – Version 2

- Storage evaluation considers new North Reservoir Pump Station
- The new clearwell considers the North Reservoir to hold the fire flow volume
- This project reduces the total deficit from 1.7 MG to 1.2 MG year 2040

2040 Evaluation		Storage Required per Storage Criteria (MG)			
Storage Facility	Storage Capacity (MG)	Operational	Fire Flow	Total	Surplus/Deficit
South WTP Tower	2.0	3.2	0	3.2	<b>-1.2</b>
North WTP Reservoir	0				
Behlen	0				
Total Usable Storage	<b>2.0</b>				



# Pump Station Evaluation

## Required:

- Pump station sized to handle maximum daily demand (MDD) and fire flow requirements

## Existing System:

- System pressure maintained by the water tower and ground storage reservoir
- High service pump station located at South Treatment Plant
- North reservoir water level maintained by discharge from wells
- Only upper portion of north reservoir available for fired demand

## Challenge:

- Loss of north reservoir capacity due to treatment addition



# Pump System Evaluation

Based on Maximum Day Demand

## Existing Capacity

- Required Capacity: 12.4 MGD
- Available Capacity: 13.2 MGD    0.8 MGD excess capacity

## 2030 Required Capacity

- Required Capacity: 13.8 MGD
- Available Capacity: 13.2 MGD    0.6 MGD deficit

## 2040 Required Capacity

- Required Capacity: 14.8 MGD
- Available Capacity: 13.2 MGD    1.9 MGD deficit



# Recommended Pump Station Improvements

- Construct a new high service pump station at the North Treatment Plant with the proposed treatment system.
- The usable volume of North Reservoir of from 0.42 MG increases to 3 MG, but as a clearwell (not system storage).
- This project also allows the City to maintain higher pressures in the transmission main near the North Reservoir.



# Elevated Storage and Pumping Recommendations

1. New Elevated Tower on west side of City
2. New high service pump station at the North Water Treatment Plant

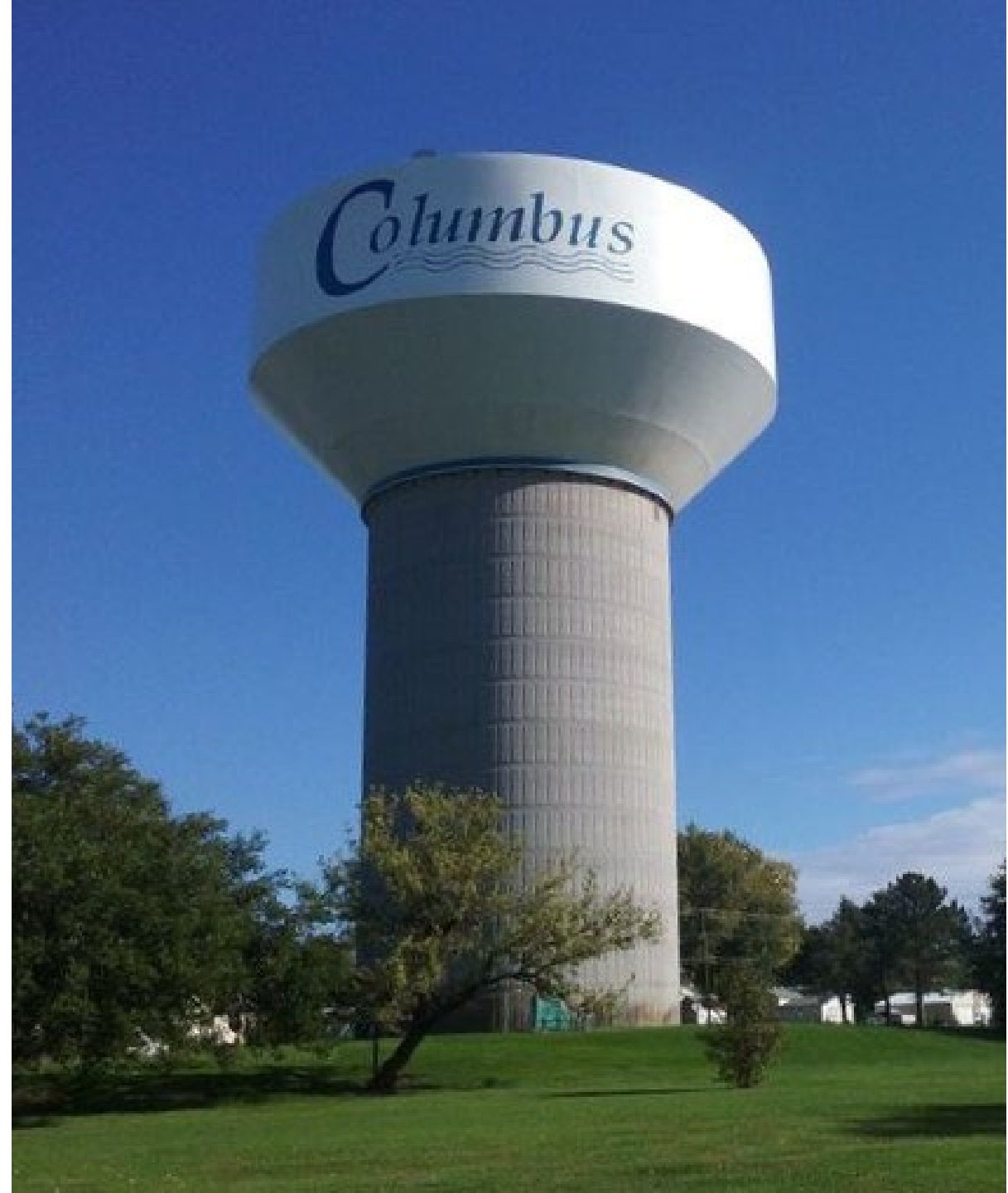

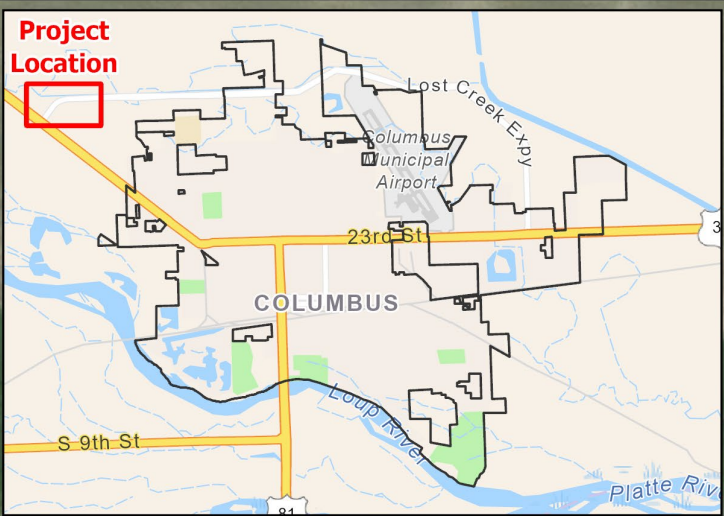

**LEGEND**

 Proposed Elevated Tower Location

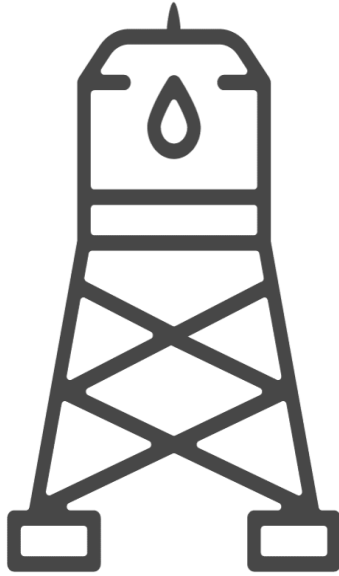

# Treatment Evaluation, Wellfield Expansion, Additional Clearwell



# Existing Conditions

- Raw water contains high levels of manganese
  - EPA secondary health advisory
  - Recommended level: 1.0 mg/L
  - 4.45 mg/l
- Current treatment: Sequestration using polyphosphate
  - Sequestration does not remove manganese
  - Recommended levels for sequestration is 0.1 mg/L



# Recommended Treatment Approach

- Manganese greensand filtration have a filter media manufactured with glauconite and coated with manganese oxide
  - Package system
  - Soluble iron and manganese binds with the media
  - Remove manganese from finished water, improving water quality

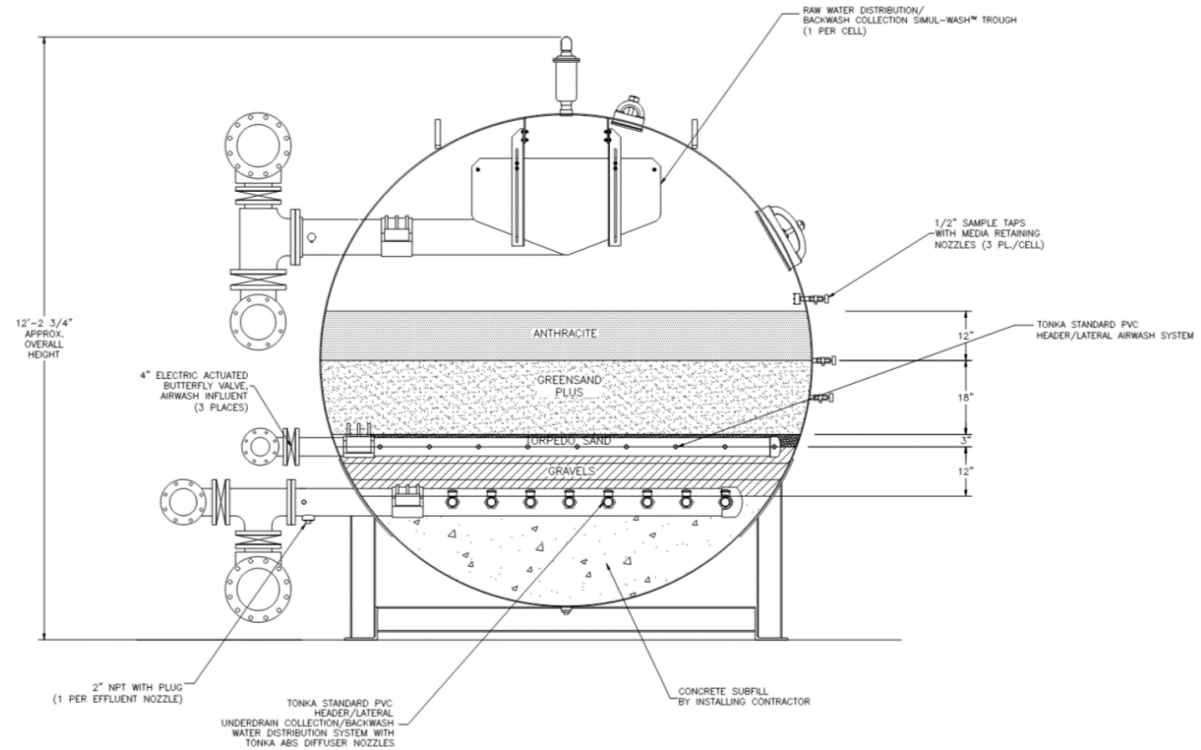

# South Treatment Plant Treatment Configuration

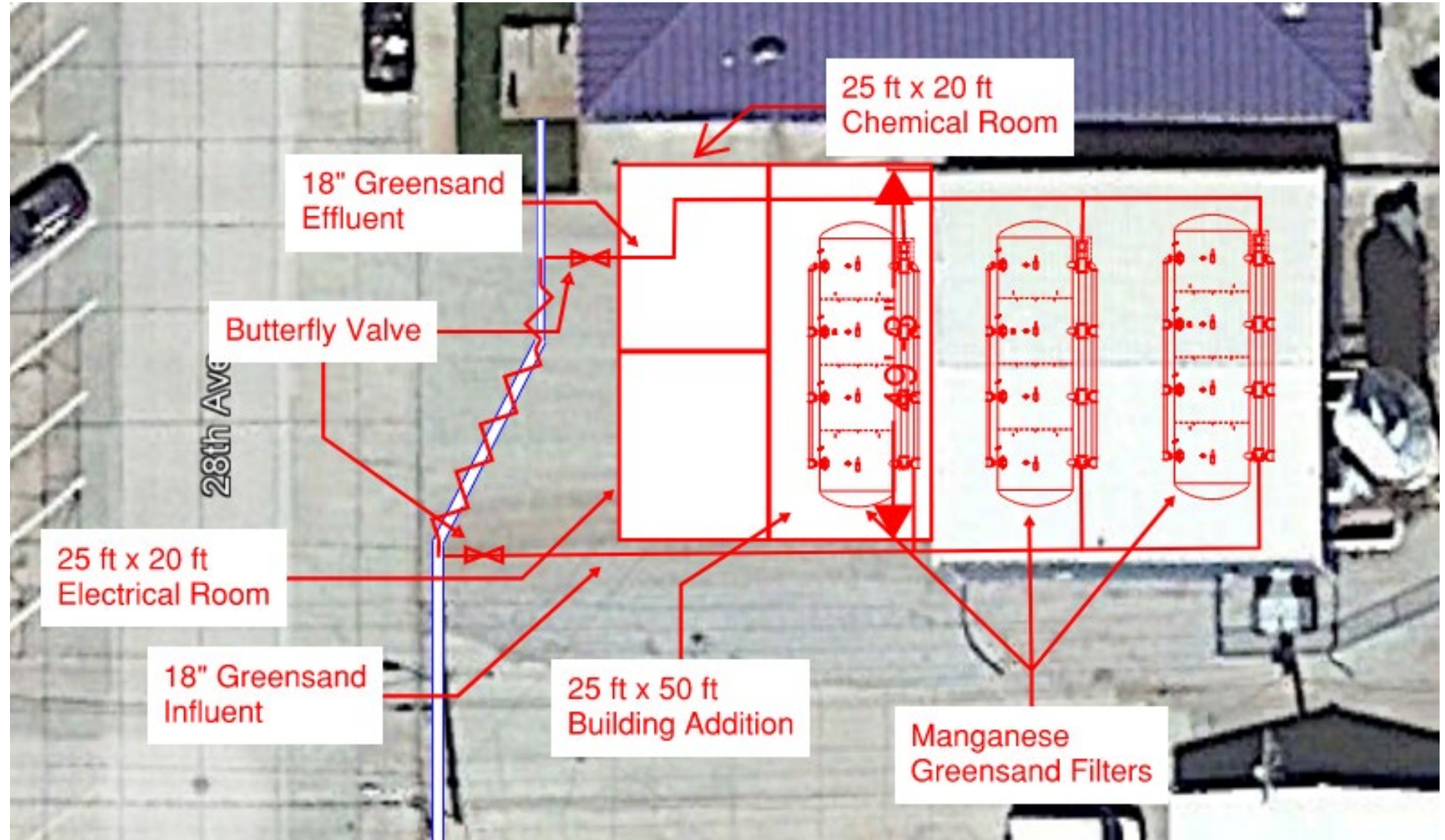

# North Treatment Plant Treatment Configuration

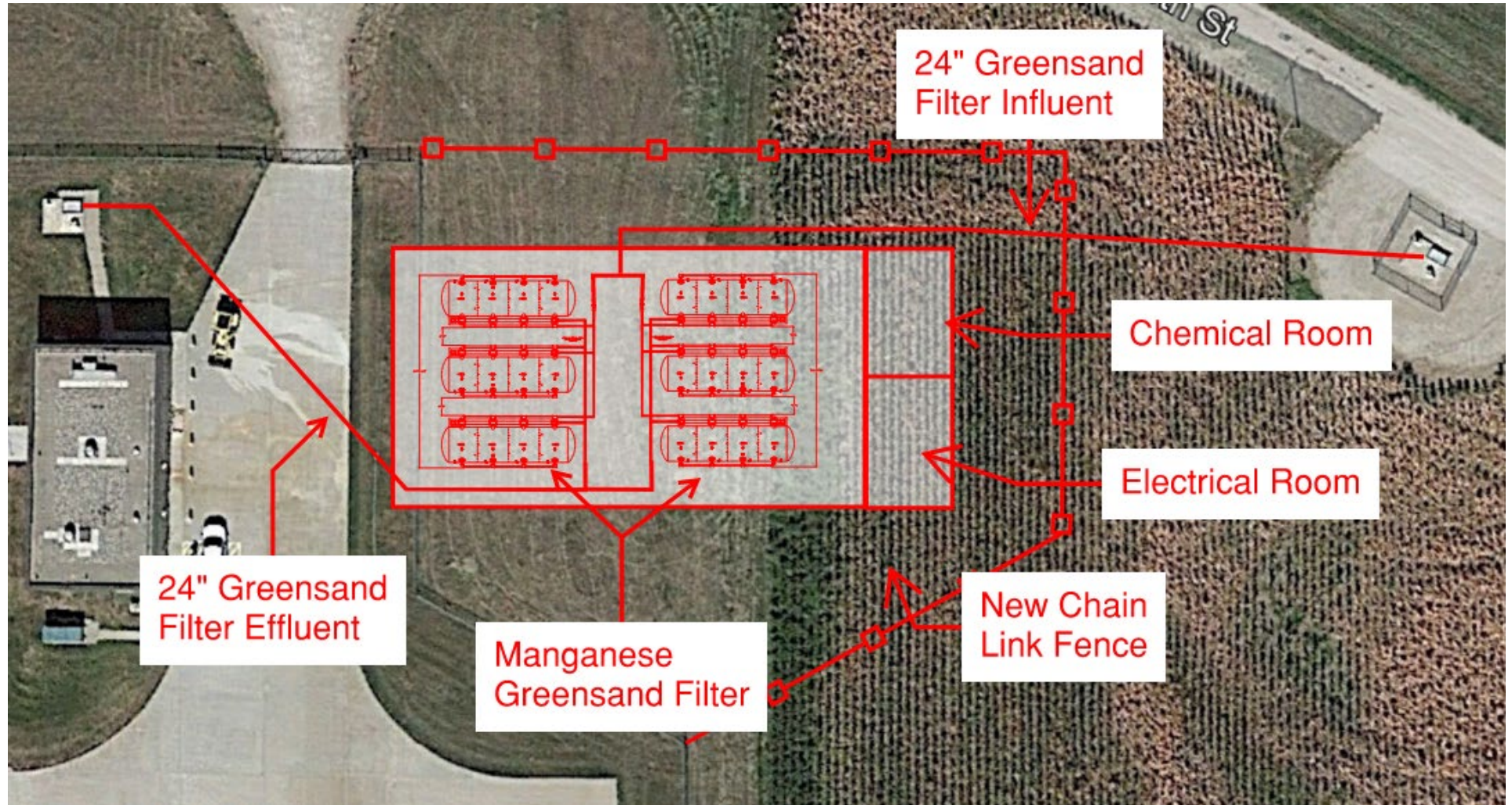

# New North Wellfield Improvements

- Based on demand projections two new wells at the north wellfield are recommended
- Each well could produce an estimated 1,500 gpm for North WTP
- One well necessary to meet the existing demands
- Second well necessary to meet the 2030 demands

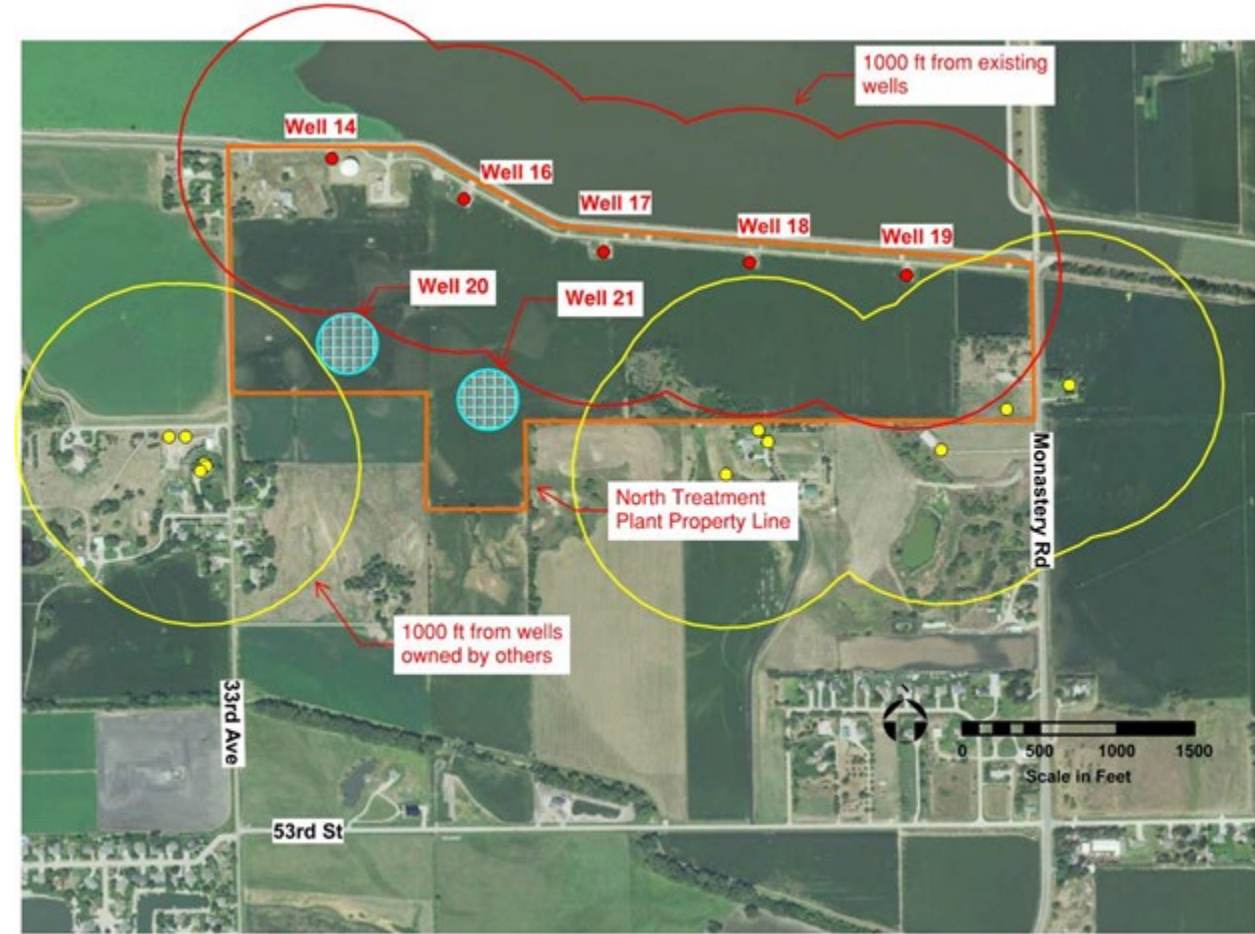

New development planned south of proposed well 21. New locations are being evaluated.



# South Treatment Plant Clearwell

- Clearwell is a ground storage reservoir that supplies the high service pumps
- Existing clearwell too small for the high service pumps
- Existing clearwell cannot be taken out of service for maintenance or inspection



# Recommended New Clearwell

- New clearwell to west of existing

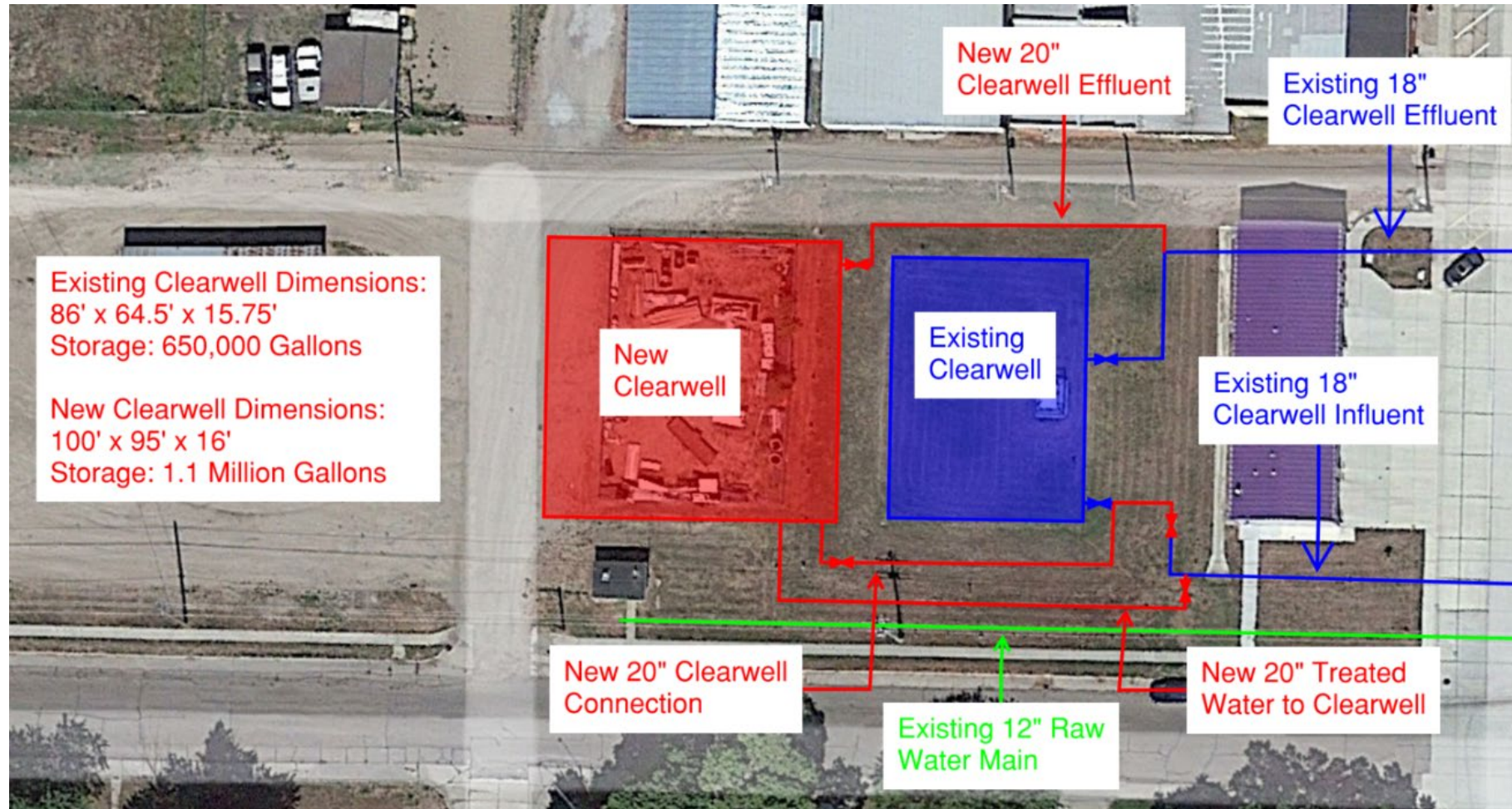

# Raw Water and Treatment Recommendations

1. Recommend greensand manganese filtration at both water treatment plants
  - South WTP 2027
  - North WTP 2032
2. Two additional 1,500 gpm wells at north wellfield
3. New 1.1 MG clearwell at South WTP (2040)





# Prioritized Capital Improvement Plan



# Prioritized CIP through 2030

Project	Description	Priority / Rank	Year	OPC
RW-1	Commission a new 1,500 gpm well	1	2026	\$3,483,000
WTP-2	Add South WTP manganese greensand filter	2	2027	\$11,967,000
RW-2	Commission a new 1,500 gpm well	3	2028	\$3,483,000
T-1	New Northwest Elevated Water Storage Tank	4	2029	\$7,670,000
WTP-3	Add North WTP manganese greensand filter	5	2031	\$34,096,000
WTP-4	North WTP High Service Pump Station	6	2032	\$8,667,000
R-1	Replacement of existing 6" main with 12" main	7	2033	\$2,144,000
P-1	Add 12" transmission main to improve fire flow	8A	2034	\$505,000
P-2	Add 12" transmission main to improve fire flow capacity	8B	2034	\$678,000
P-5	Add 12" main to improve conveyance and increase system pressures	8C	2034	\$1,105,000

# Longer term improvements: Post 2030

Project	Description	Priority / Rank	Year	OPC
WTP-1	New clearwell at South WTP	9	2040	\$5,309,000
P-3	Add 8" main to improve localized pressure and fire flow	10A	2040	\$231,000
P-4	Add 12" main to improve transmission	10B	2040	\$803,000
R-2	Replace 4" mains near the airport with 6" mains	10C	2040	\$162,000
R-3	Replace remaining 4" mains with 6" mains to address fire flow deficiencies	11	2040	\$3,960,000



Questions?



HDR

# Prioritized CIP

Project	Year	Trigger	Improvement
WTP-1	2040	Capacity Deficiency	Add additional storage with new clearwell at South WTP
WTP-2	2030	Current Treatment Deficiency	South WTP manganese greensand filter
WTP-3	2026	Current Treatment Deficiency	North WTP manganese greensand filter
WTP-4	2027	Capacity Deficiency	North WTP high service pump station
RW-1	2025	Growth (MDD of 12.3 MGD)	Commission a new 1,500 gpm well (well 20)
RW-2	2028	Growth (MDD of 13.1 MGD)	Commission a new 1,500 gpm well (well 21)
T-1	2029	Growth, MDD increase by 2030	New northeast 1.25 MG storage tank



# Improvement Cost Summary

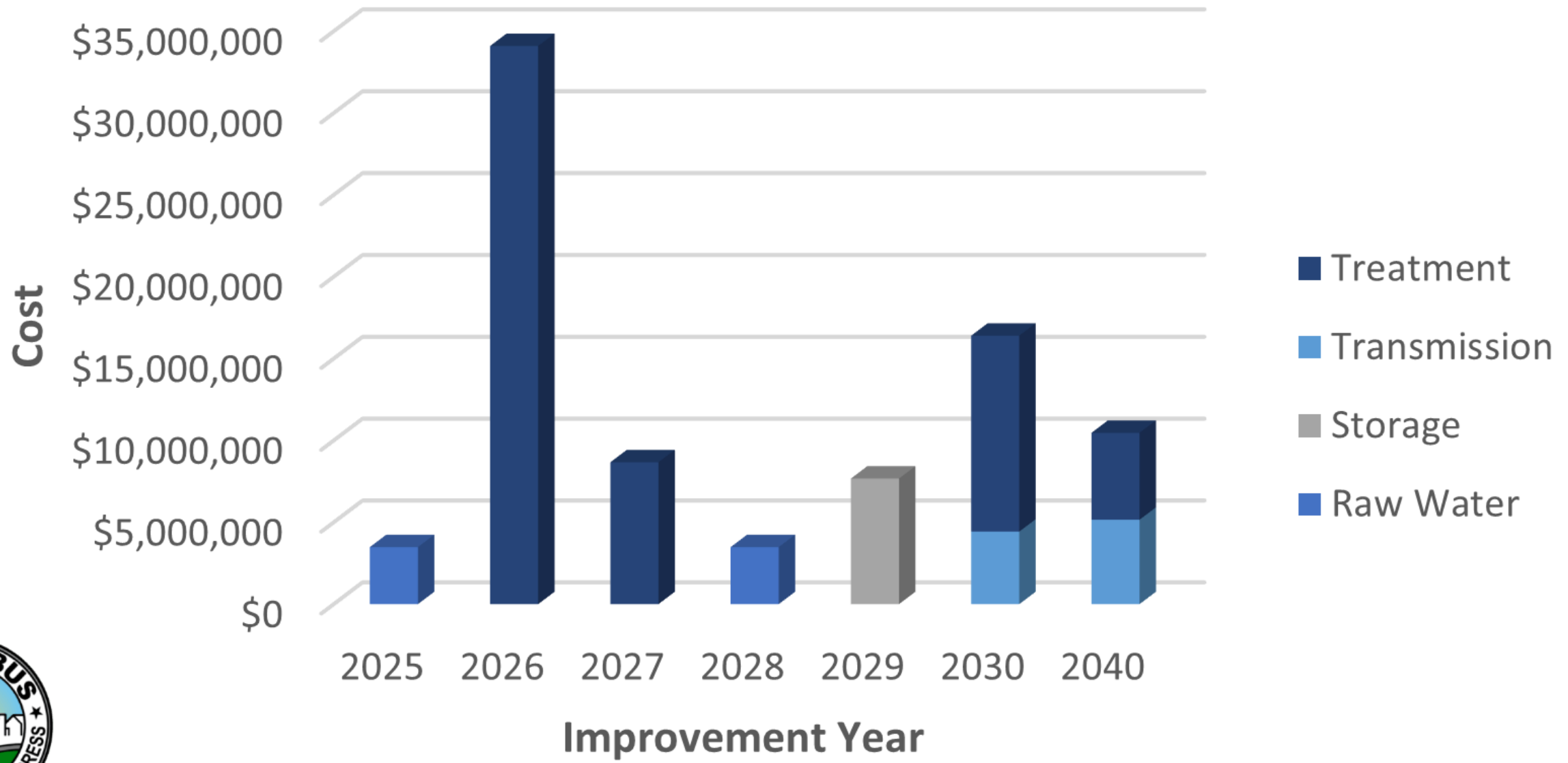

# Transmission and Distribution Improvements

Project	Proposed Diameter	Length (FT)	Improvement Year	Trigger
P-1	12	2,430	2030	Increase localized fire flow capacity
P-2	12	2,890	2030	Improve fire flow capacity and transmission
P-3	8	1,170	2040	Improve fire flow and transmission
P-4	12	3,510	2040	Improve transmission reliability
P-5	12	5425	2030	Address low pressures and system reliability
R-1	12	9,090	2030	Address aging infrastructure and main breaks and increase east-west conveyance
R-2	6 to 8"	900	2040	Replace 4-inch main adjacent to airport with 6-inch mains to complete 6-inch loop
R-3	6 to 8"	22,000	2040	Replace remaining 4-inch mains in the system with 6- to 8inch mains



# North Reservoir Pump Station

- Main pressure zone in Columbus has floating storage
- Floating storage zones should be sized to handle maximum daily demand (MDD) and fire flow requirements
  - North high service pump station must be sized to handle MDD
- Pumping capacity is projected to be deficient by 2027
  - New high service pump station to provide 8.6 MGD of capacity recommended

Pressure Zone	Criteria	MDD or PHD (MGD)	Firm Capacity to Boosted Zone (MGD)	Required Capacity (MGD)	Available Firm Capacity (MGD)	Net (MGD)
Main Pressure Zone	MDD	14.8	0.3	14.8	13.2	<b>-1.9</b>

### **3. Water and Wastewater Rate Study**





# Water and Wastewater Rate Study



03/6/2024





## Agenda

- A** Rate Study Overview
- B** Revenue Requirement
- C** Cost of Service
- D** Rate Design
- E** Questions and Discussion

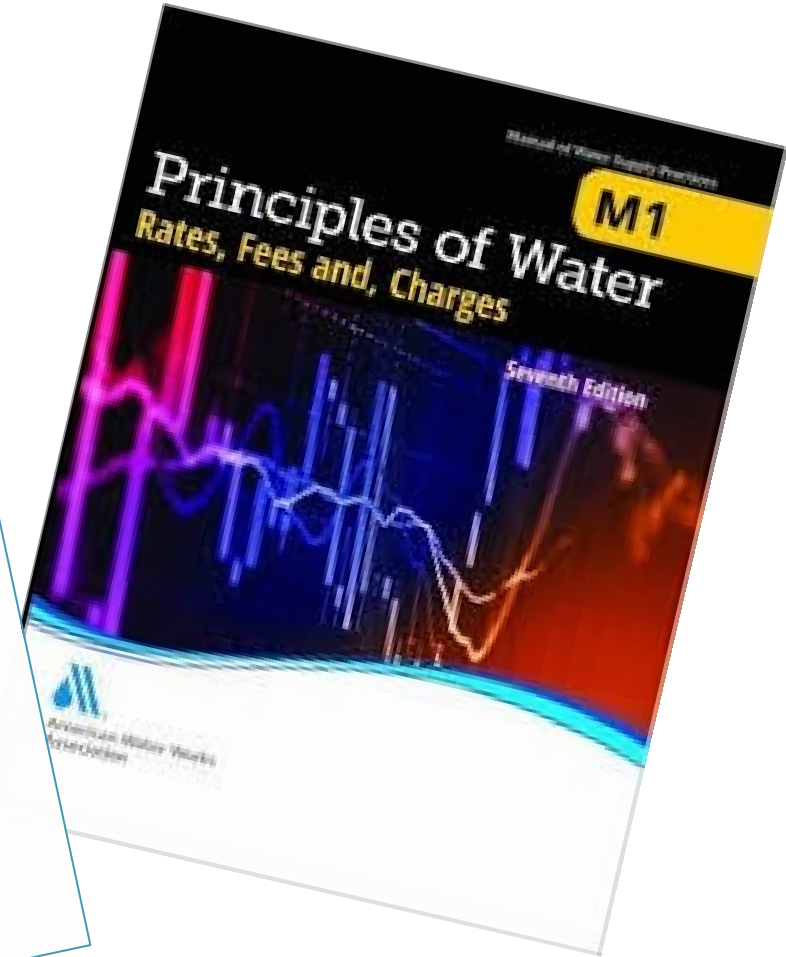



# A Rate Study Overview



# Rate Study Purpose

- Provide sufficient revenue to operate and maintain the City's water and sewer infrastructure
- Develop cost-based and proportional rates to reflect customer characteristics and system infrastructure requirements
- Provide financial planning:
  - Costs for labor, materials, equipment, etc.
  - Funding capital improvement needs
  - Maintain target minimum reserves
  - Meet debt coverage requirements
- Use generally accepted methodologies tailored to the City's system and customer characteristics



# Developing Cost-Based Rates

## Revenue Requirement

*Compares the revenue of the utility to the expenses to evaluate the level of overall rates*

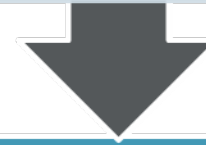

## Cost of Service

*Equitably allocates and distributes the revenue requirement between the various customer classes of service*



## Rate Design

*Design rates for each class of service to meet the revenue needs of the water utility, along with any other rate design goals and objectives*



# Key Issues



## Adequately fund annual operating costs for both utilities

Costs **increase** annually from inflation

**Maintain** prudent reserve levels



## Providing sufficient annual renewal and replacement funding

**Water** – significant capital improvement needs

**Sewer** – current rates support annual capital funding needs



## Cost-based and proportional rates

Based on customer demands – avoid one class subsidizing another, all need to pay **“fair share”**



# B Revenue Requirement



# Revenue Requirement Overview

## Compares utility revenues to expenses

- Determines the level of rate revenue adjustment necessary

## Uses prudent financial planning criteria

- Adequate funding of renewal and replacements
- Maintaining sufficient ending reserve balances

## Reviews a specific time period

- Typically five-to-ten-year period

## Utilities are analyzed on a “stand-alone basis”

- No transfer from other City funds
- Rates need to support operations and capital

## Utilizes the “cash basis” methodology

- Generally accepted method for municipal utilities



# Revenue Requirement Key Assumptions

- Rate revenues independently calculated
  - Current adopted rates
  - Recent customer characteristics
- O&M expenses based on adopted 2023 budget
  - Projected through 2033 based on inflation estimates
  - Water includes additional O&M related to capital improvements
- Capital funding plan developed based on current capital plans
  - Ongoing water master plan
- Rate setting projections focuses on the next five-year period (2024-2028)
  - Developed projections for full 10-years



# Water Capital Funding Analysis – Smooth Rate Alternative

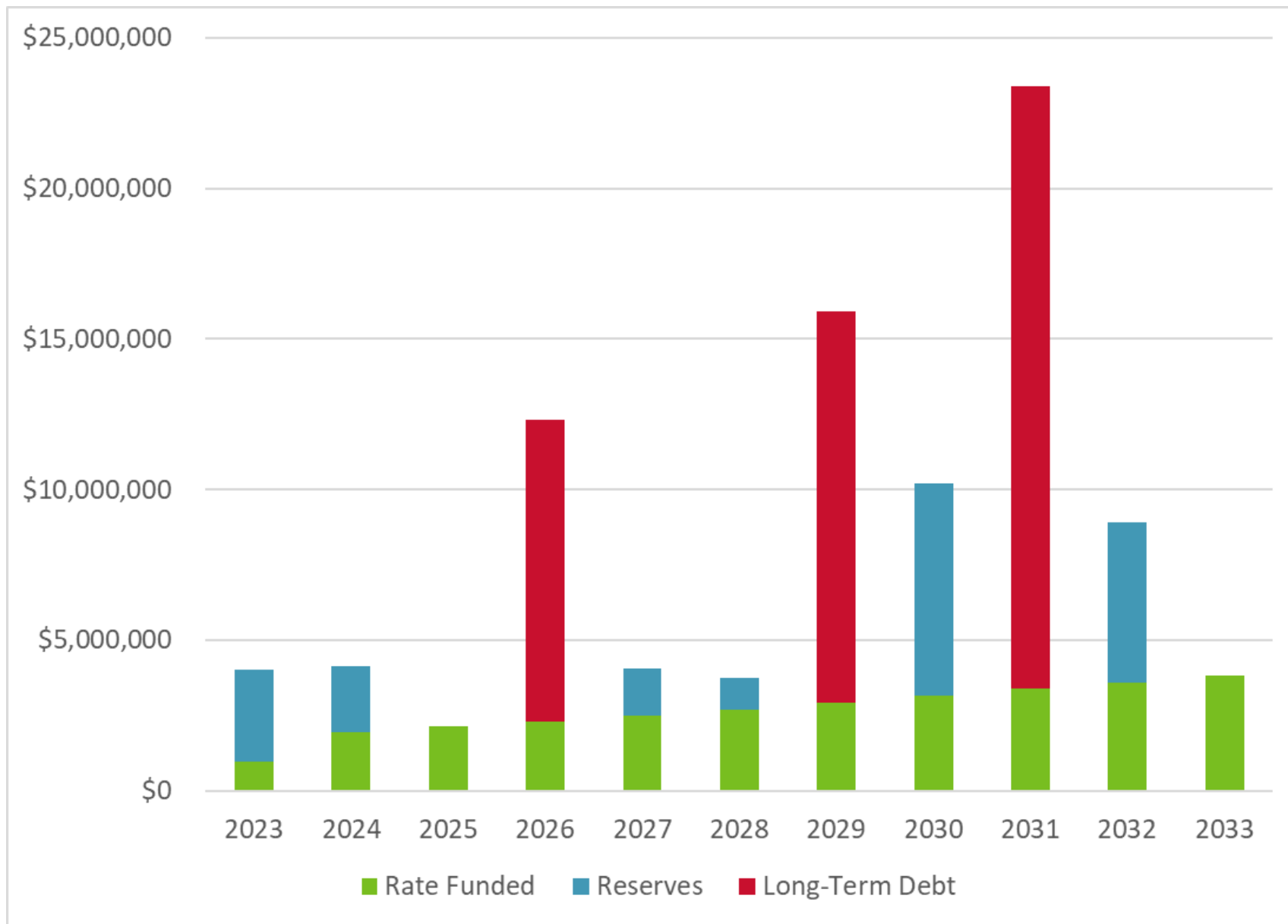



# Water Capital Funding Analysis – Upfront Rate Alternative

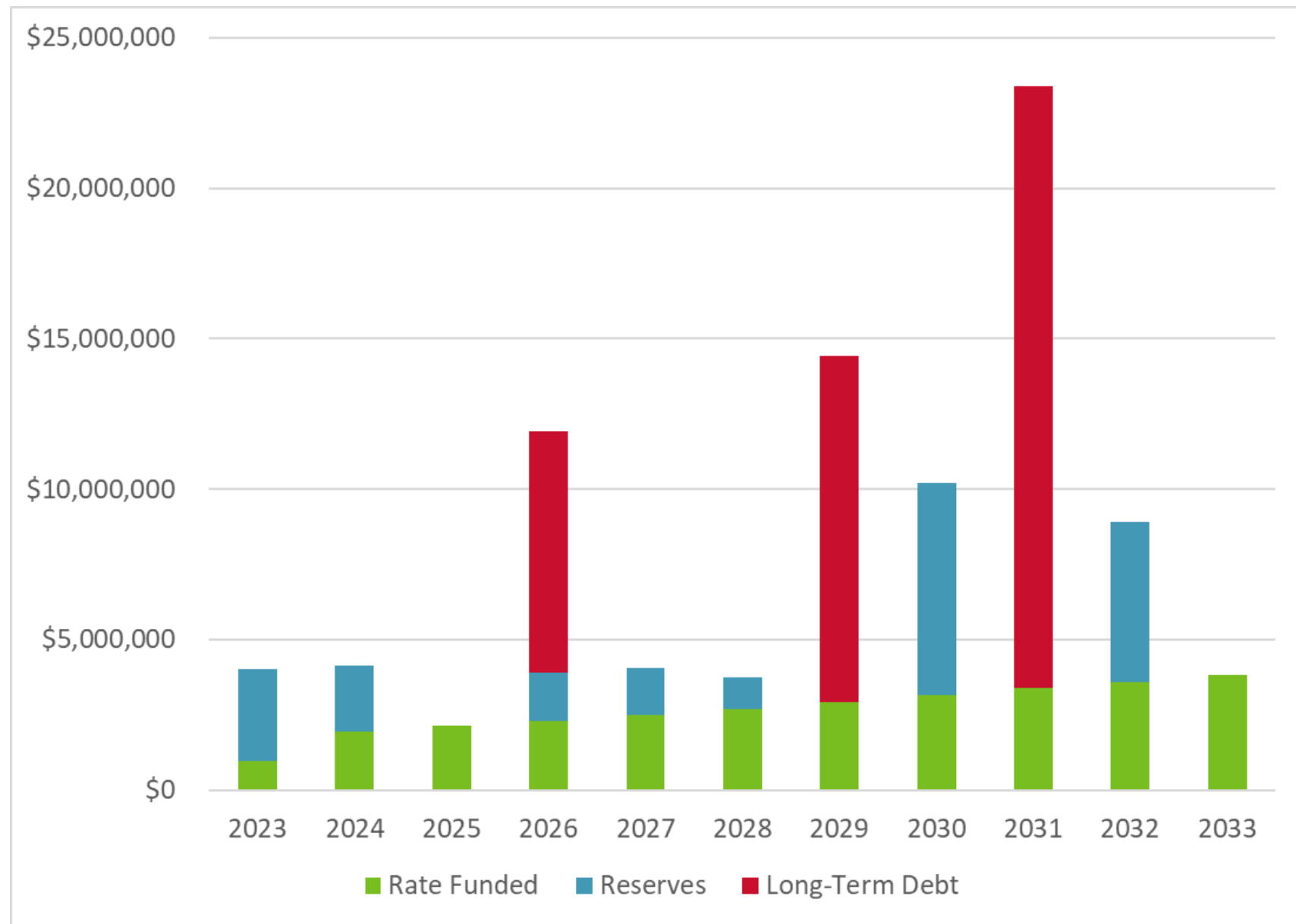

Results in \$3.5 Million less than “Smooth” Rate Alternative



# Water Revenue Requirement – Smooth Alternative

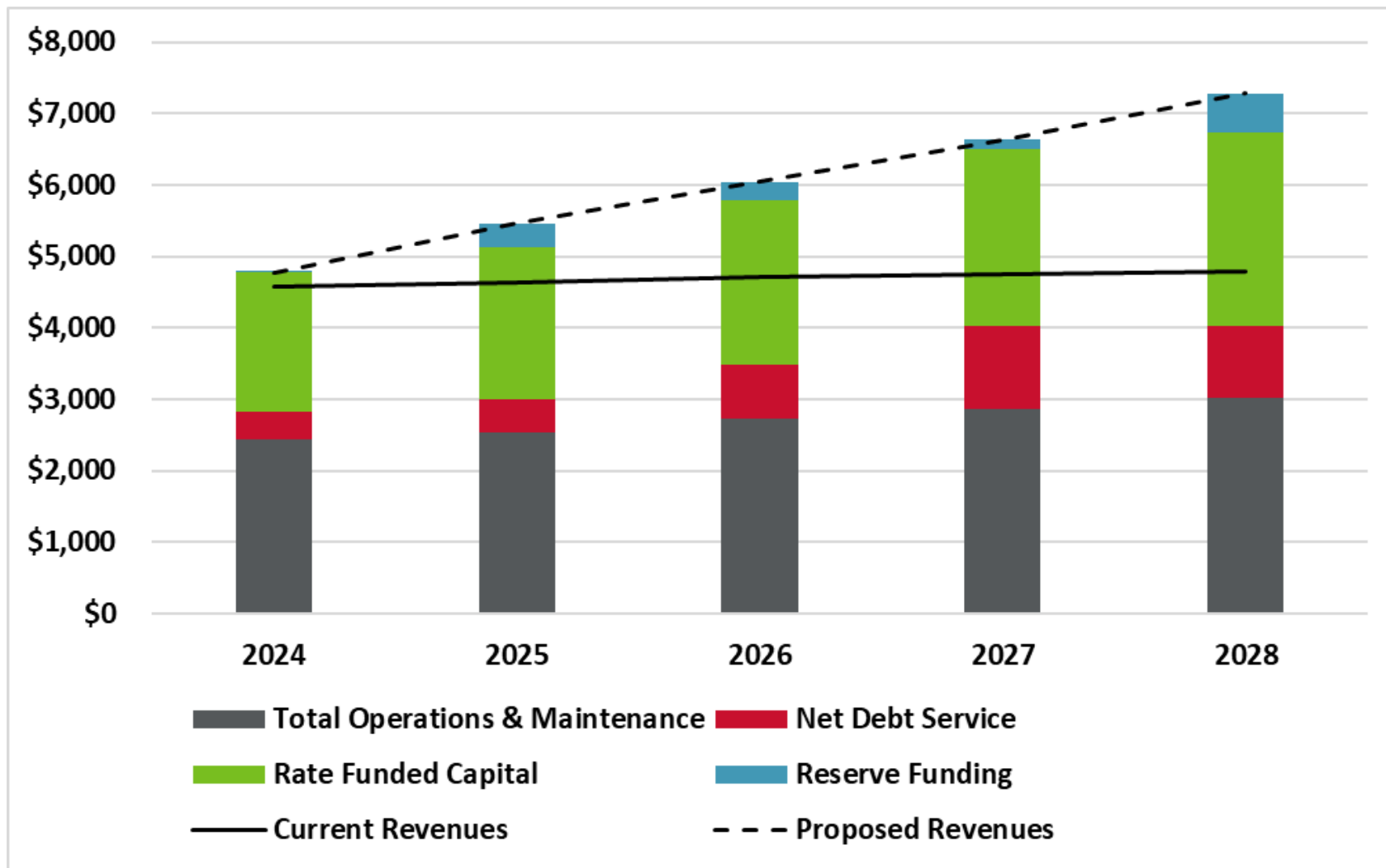



# Water Ending Reserves Smooth Alt

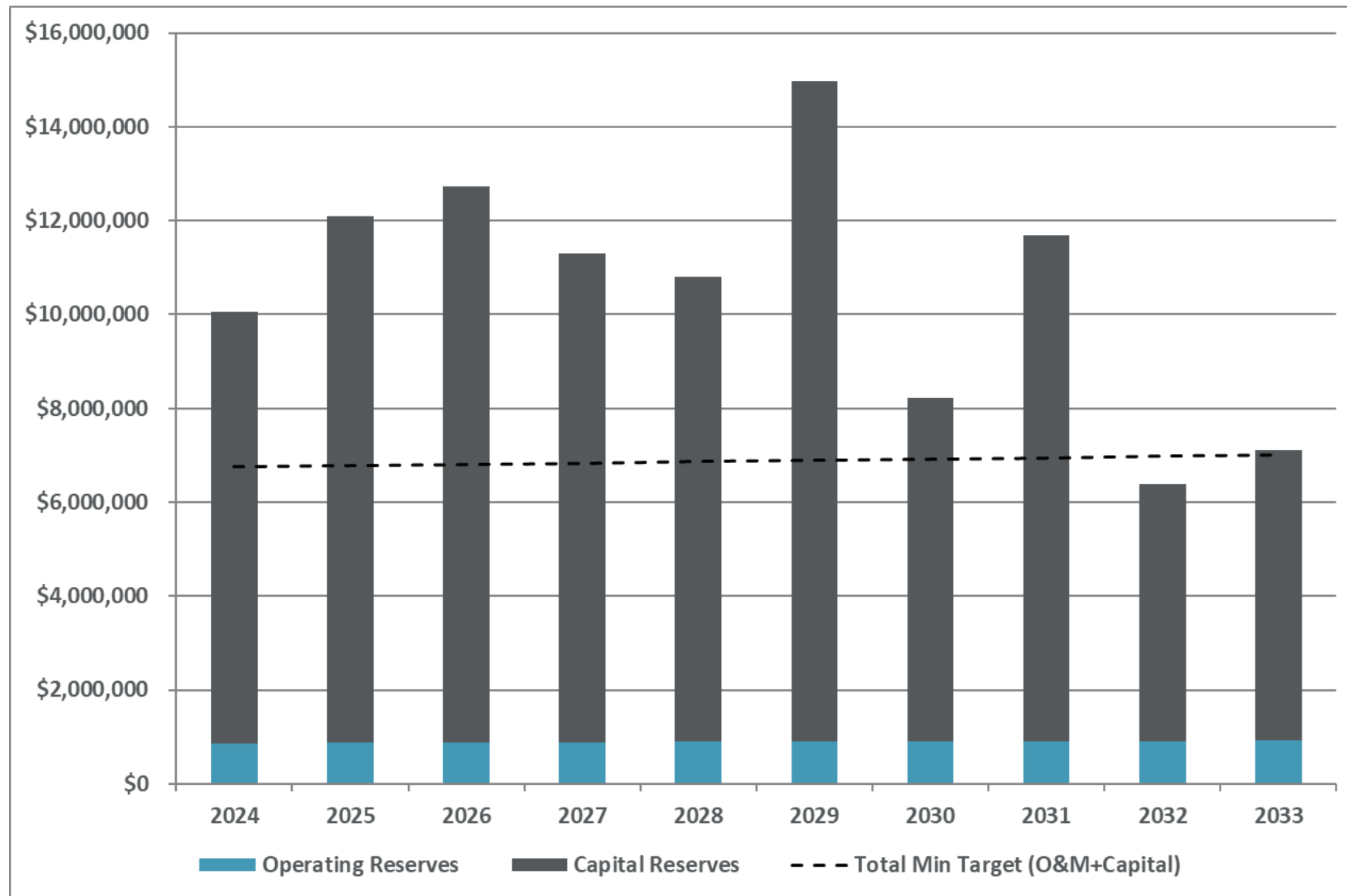

Minimum Target = 90 days of O&M + 1-year of CIP less Debt Funded



# Sewer Capital Funding Analysis

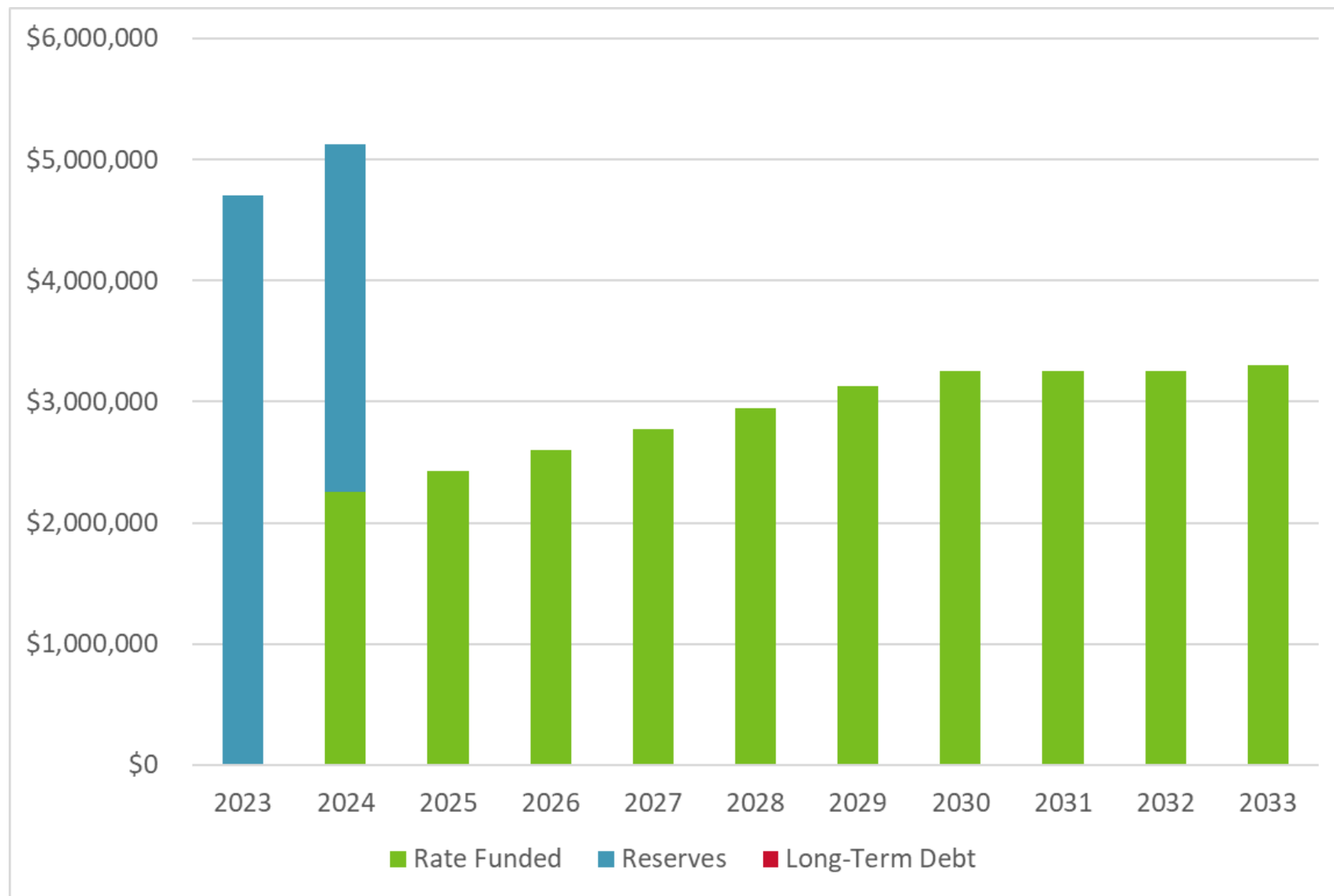



# Sewer Revenue Requirement

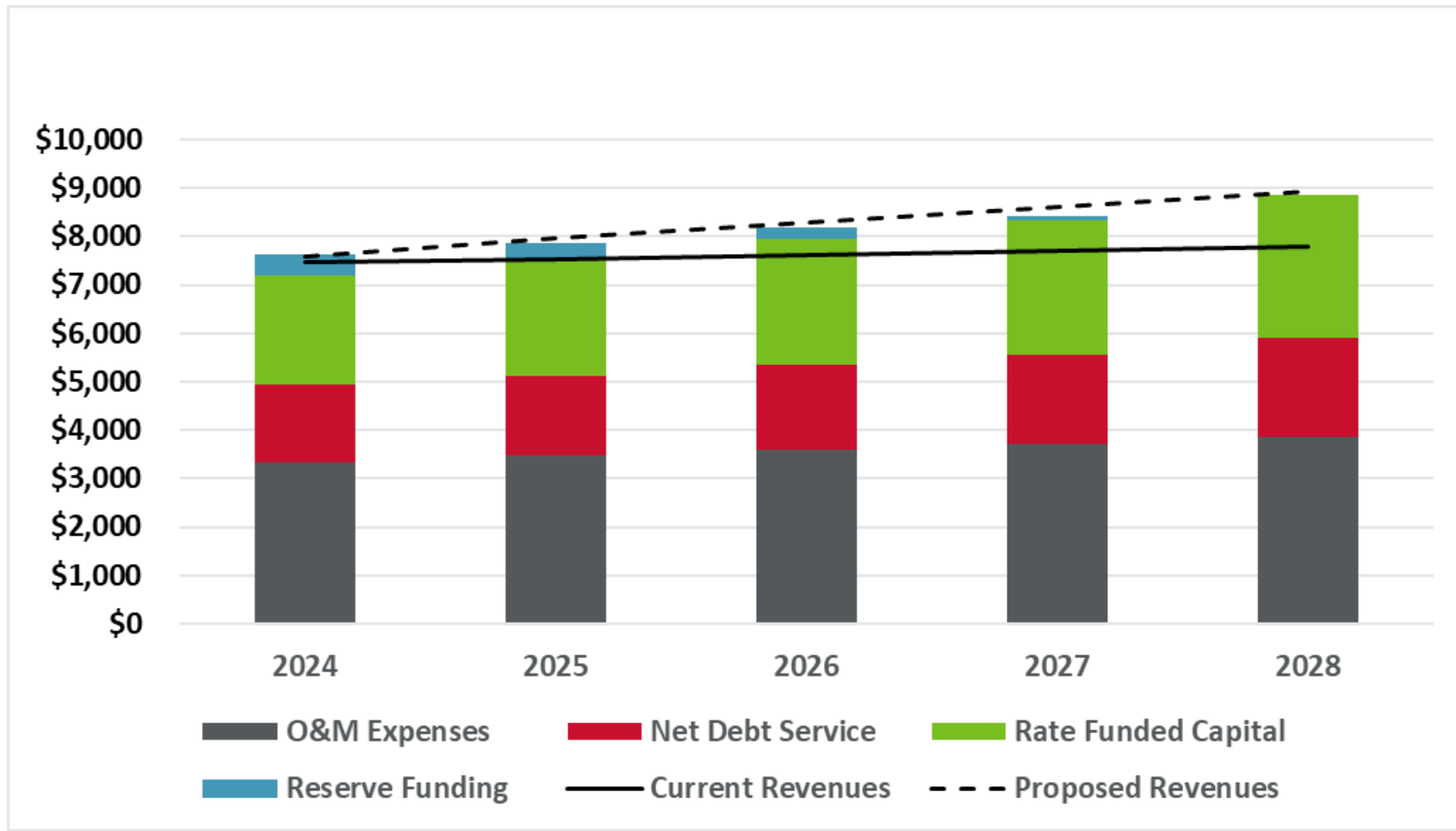



# Sewer Ending Reserves

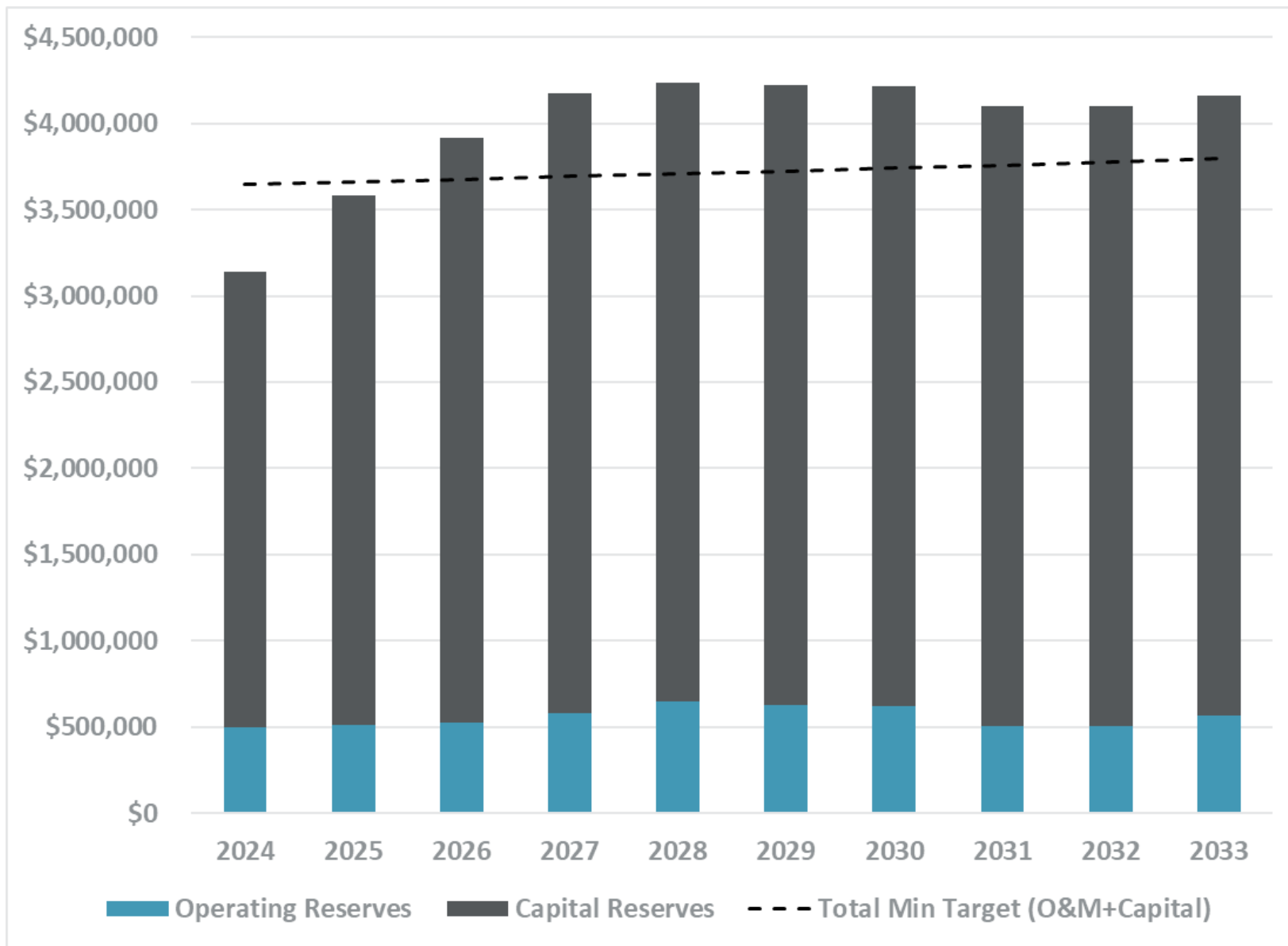

Minimum Target = 90 days of O&M + 1-year of CIP



# C Cost of Service



# Water Cost of Service

- Key rate drivers
  - Average annual consumption
  - Peak consumption/demands
- Allocated and distributed the revenue requirement for 2024
- Some cost differences exist
- First cost of service completed in some time
- Recommend across the board rate adjustments





# Sewer Cost of Service

- Key rate drivers:
  - Average wastewater volumes
  - Strength of the wastewater volumes
- Allocated and distributed the revenue requirement for 2024
- Minimal differences in the cost of service
- Recommend across the board adjustments
- First cost of service study completed in some time





# C Rate Design



# Rate Design Overview

Based on the results of the revenue requirement and cost of service analyses

Meet the rate design goals and objectives of the City

Produce sufficient revenues to meet the target revenues of each utility, and each class of service

Are cost-based and equitable



# Rate Design Summary

Maintained the current rate structure for each utility

Service charge – Monthly fee increasing by meter size

Usage charge – Flat fee per 1000 gallons consumed for all customers

Maintained outside city rate differential



# Overview of Rate Design Alternatives

## **Water Alternative 1 – “Smooth” Rate Increase**

- Equal adjustments for all customers
- Same 9.5% rate increase each year

## **Water Alternative 2 – “Upfront” Rate Increase**

- Equal adjustments for all customers
- 15% increases first three years and 6% each year after

## **Sewer – “Across the Board”**

- Equal adjustments for all customers
- Same 3% increase for each year of evaluation period



# Previous Sewer Rate Increase Comparison

2012 - 2022 Sewer Rate Increases: Single Family Residential (Monthly Bill)

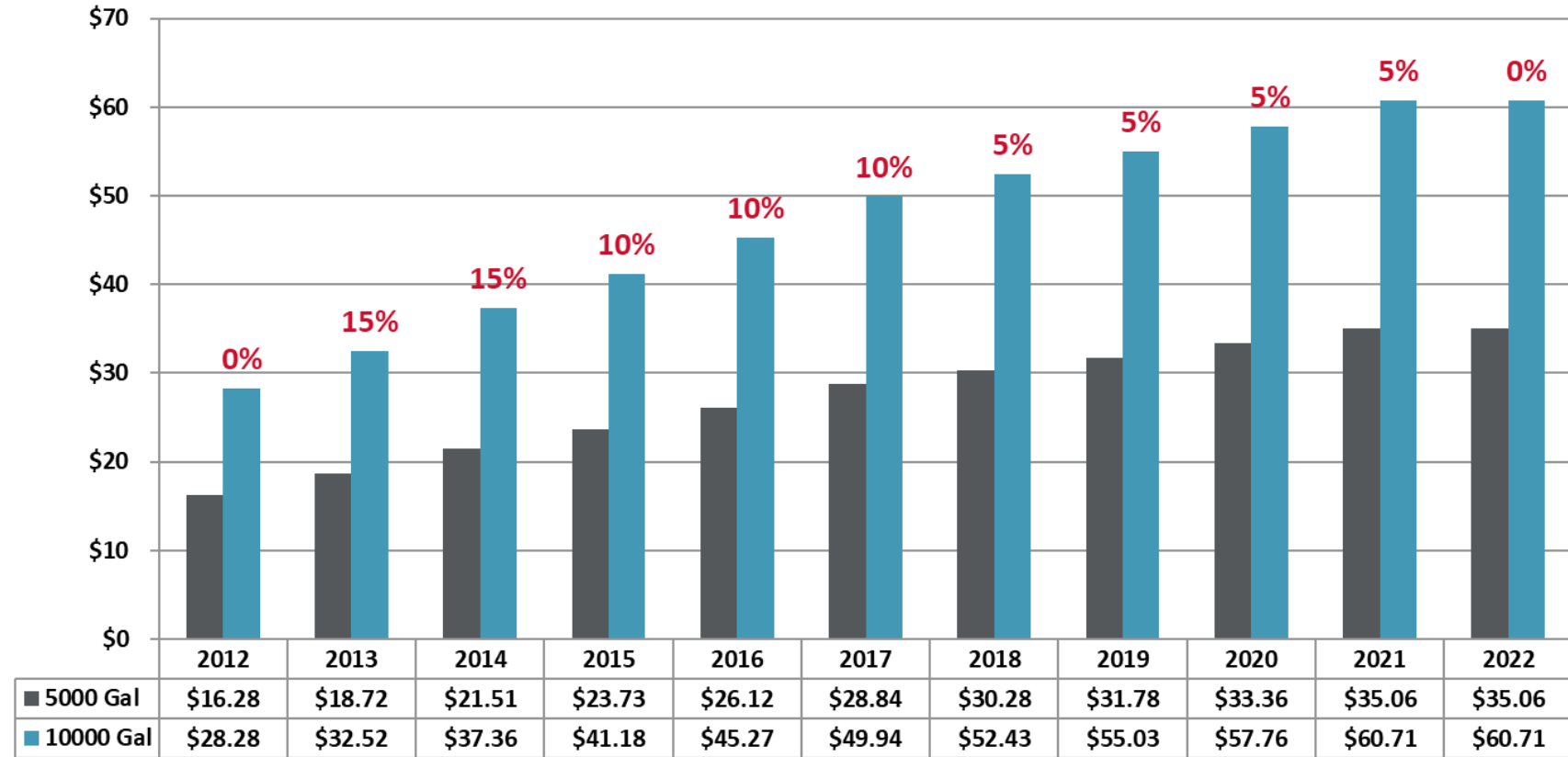

- Previous sewer rate increases were needed to update system in 2012
- Improvements required rate increases through 2021
- Columbus sewer infrastructure has improved, and only inflationary rate increases are needed
- Columbus water system is in a similar place sewer was in 2012





# Why are Water Rates Increasing

1. Adjust for inflation
2. Capital – increase of funding for annual renewal, replacement, and needed improvements
  - New wells for expected increased demand
  - Storage and transmission improvements
  - Manganese treatment
3. Reserves – maintain adequate funds to support cash flow, emergencies, and credit ratings
4. Maintain adequate financial metrics needed to issue future long-term debt



# Water Rate Transition Plan Alternatives

	2023	2024	2025	2026	2027	2028
<b>Alt 1 – Smooth Increase</b>						
Percent Change	--	9.5%	9.5%	9.5%	9.5%	9.5%
Avg Customer Bill	\$20.28	\$22.21	\$24.32	\$26.63	\$29.16	\$31.93
Monthly Change	--	\$1.93	\$2.11	\$2.31	\$2.53	\$2.77
<b>Alt 2 – Upfront Increase</b>						
Percent Change	--	15%	15%	15%	6%	6%
Avg Customer Bill	\$20.28	\$26.82	\$30.84	\$32.69	\$34.66	\$36.73
Monthly Change	--	\$3.04	\$3.50	\$4.02	\$1.85	\$1.96
<sup>3</sup> / <sub>4</sub> Meter Billing Charge + 10,000 Gal						



# Proposed Residential Water Rates, Smooth Alt

	<i>Present Rates</i>	<i>Proposed Rates Alt 1</i>				
		<b>2024</b>	<b>2025</b>	<b>2026</b>	<b>2027</b>	<b>2028</b>
<b>Percent Change</b>		9.5%	9.5%	9.5%	9.5%	9.5%
<b>Service Charges</b>	<i>\$ / Mo</i>					
3/4"	\$6.78	\$7.42	\$8.13	\$8.90	\$9.75	\$10.67
1"	6.78	7.42	8.13	8.90	9.75	10.67
1-1/2"	20.35	22.28	24.40	26.72	29.26	32.04
2"	33.92	37.14	40.67	44.53	48.77	53.40
3"	67.85	74.30	81.35	89.08	97.55	106.81
4"	101.77	111.44	122.02	133.62	146.31	160.21
6"	203.54	222.88	244.05	267.23	292.62	320.42
8"	339.24	371.47	406.76	445.40	487.71	534.04
10"	508.86	557.20	610.14	668.10	731.57	801.07
12"	949.86	1,040.10	1,138.91	1,247.10	1,365.58	1,495.31
<b>Consumption Charge Inside</b>	<i>\$ / 1000</i>					
All Consumption	\$1.35	\$1.48	\$1.62	\$1.77	\$1.94	\$2.13
<b>Consumption Charge Outside</b>	<i>\$ / 1000</i>					
All Consumption	\$2.68	\$2.93	\$3.21	\$3.52	\$3.85	\$4.22



# Proposed Residential Water Rates, Upfront Alt

	<i>Present Rates</i>	<i>Proposed Rates Alt 2</i>				
		<b>2024</b>	<b>2025</b>	<b>2026</b>	<b>2027</b>	<b>2028</b>
<b>Percent Change</b>		15%	15%	15%	6%	6%
<b>Service Charges</b>	<i>\$/ Mo</i>					
3/4"	\$6.78	\$7.80	\$8.97	\$10.31	\$10.93	\$11.59
1"	6.78	7.80	8.97	10.31	10.93	11.59
1-1/2"	20.35	23.40	26.91	30.95	32.81	34.78
2"	33.92	39.01	44.86	51.59	54.68	57.96
3"	67.85	78.03	89.73	103.19	109.38	115.95
4"	101.77	117.04	134.59	154.78	164.07	173.91
6"	203.54	234.07	269.18	309.56	328.13	347.82
8"	339.24	390.13	448.64	515.94	546.90	579.71
10"	508.86	585.19	672.97	773.91	820.35	869.57
12"	949.86	1,092.34	1,256.19	1,444.62	1,531.30	1,623.17
<b>Consumption Charge Inside</b>	<i>\$/ 1000</i>					
All Consumption	\$1.35	\$1.55	\$1.79	\$2.05	\$2.18	\$2.31
<b>Consumption Charge Outside</b>	<i>\$/ 1000</i>					
All Consumption	\$2.68	\$3.08	\$3.54	\$4.08	\$4.32	\$4.58



# 2025 Residential Monthly Water Bill

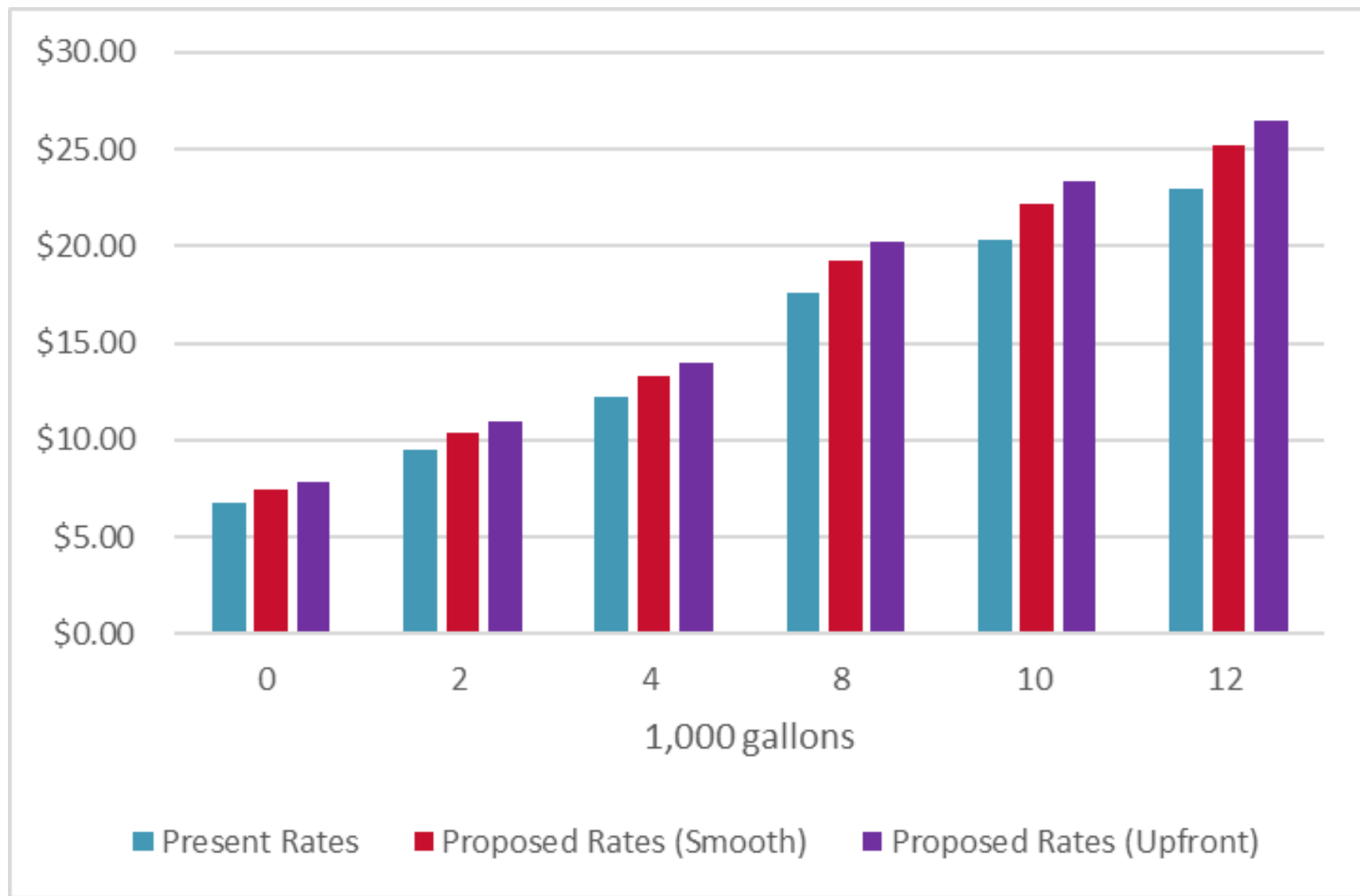



# Smooth Local Residential Water Bill Comparison

**Water Rate Comparison: Single Family Residential 3/4" Meter  
(Monthly Bill)**

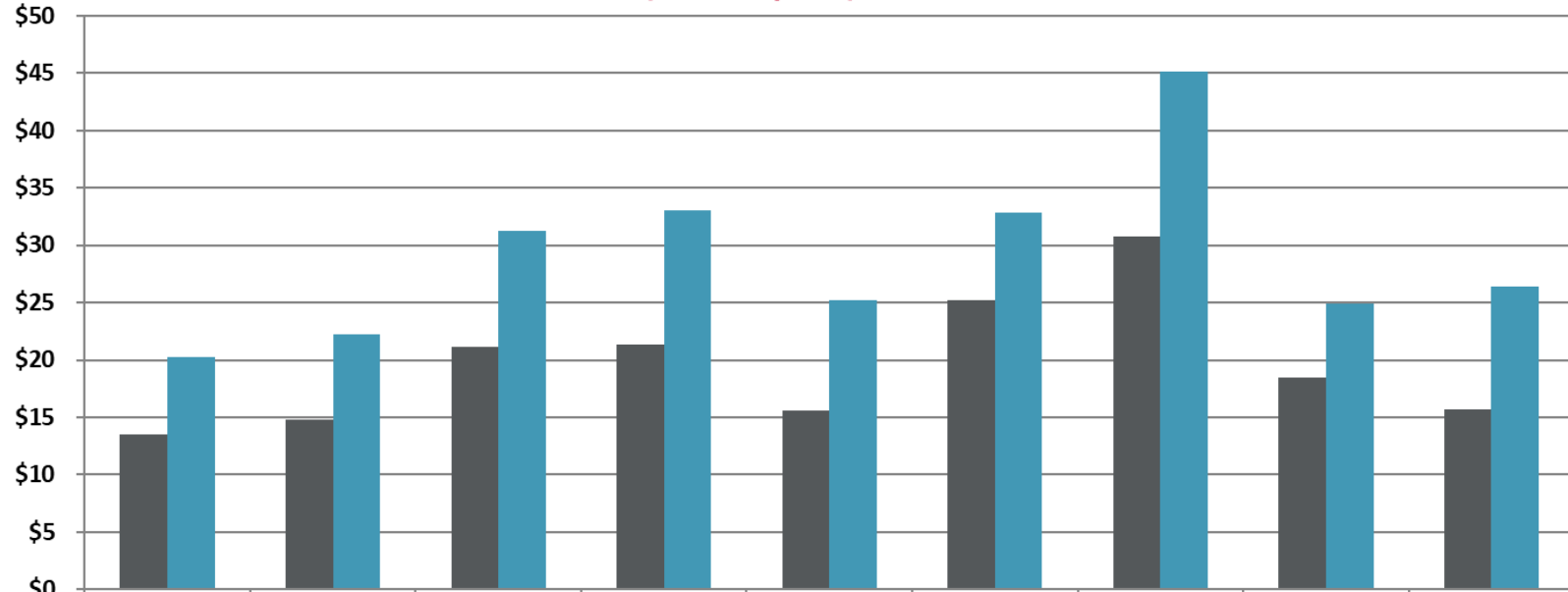

	Present	Proposed	Average Comparison	Kearney	Papillion	North Platte	Hastings	Fremont	Norfolk
City of Columbus									
5000 gal	\$13.53	\$14.82	\$21.15	\$21.32	\$15.55	\$25.24	\$30.72	\$18.45	\$15.65
10000 gal	\$20.28	\$22.21	\$31.25	\$33.02	\$25.20	\$32.87	\$45.09	\$24.92	\$26.41



# Projected Sewer Rate Transition Plan

	2023	2024	2025	2026	2027	2028
<b>Sewer</b>						
Percent Change	--	3%	3%	3%	3%	3%
Avg Customer Bill <sup>2</sup>	\$35.06	\$36.11	\$37.20	\$38.31	\$39.46	\$40.64
Monthly Change	--	\$1.05	\$1.08	\$1.12	\$1.15	\$1.18

<sup>3</sup>/<sub>4</sub> Meter Billing Charge + 5,000 Gal



# Proposed Sewer Rates

	<i>Present Rates</i>	<i>Proposed Rates</i>				
		<b>2024</b>	<b>2025</b>	<b>2026</b>	<b>2027</b>	<b>2028</b>
<b>Percent Change</b>		3%	3%	3%	3%	3%
<b>Service Charges</b>	<i>Rate</i>					
3/4"	\$9.41	\$9.69	\$9.98	\$10.28	\$10.59	\$10.91
1"	9.41	9.69	9.98	10.28	10.59	10.91
1-1/2"	28.23	29.08	29.95	30.85	31.77	32.73
2"	47.05	48.46	49.92	51.41	52.96	54.54
3"	94.09	96.91	99.82	102.81	105.90	109.08
4"	141.14	145.37	149.74	154.23	158.85	163.62
6"	282.28	290.75	299.47	308.45	317.71	327.24
8"	470.47	484.58	499.12	514.10	529.52	545.40
10"	705.71	726.88	748.69	771.15	794.28	818.11
12"	1,317.33	1,356.85	1,397.56	1,439.48	1,482.67	1,527.15
<b>Consumption Charge Inside</b>	<i>\$/1000</i>					
All Consumption	\$5.13	\$5.28	\$5.44	\$5.61	\$5.77	\$5.95
<b>Consumption Charge Outside</b>	<i>\$/1000</i>					
All Consumption	\$7.37	\$7.59	\$7.82	\$8.05	\$8.29	\$8.54
<b>Sewer Surcharge Rates</b>	<i>Per Pound</i>					
BOD	\$0.234	\$0.241	\$0.248	\$0.256	\$0.263	\$0.271
TSS	\$0.194	\$0.200	\$0.206	\$0.212	\$0.218	\$0.225
Grease	\$0.388	\$0.400	\$0.412	\$0.424	\$0.437	\$0.450



# 2025 Residential Monthly Sewer Bill Comparison

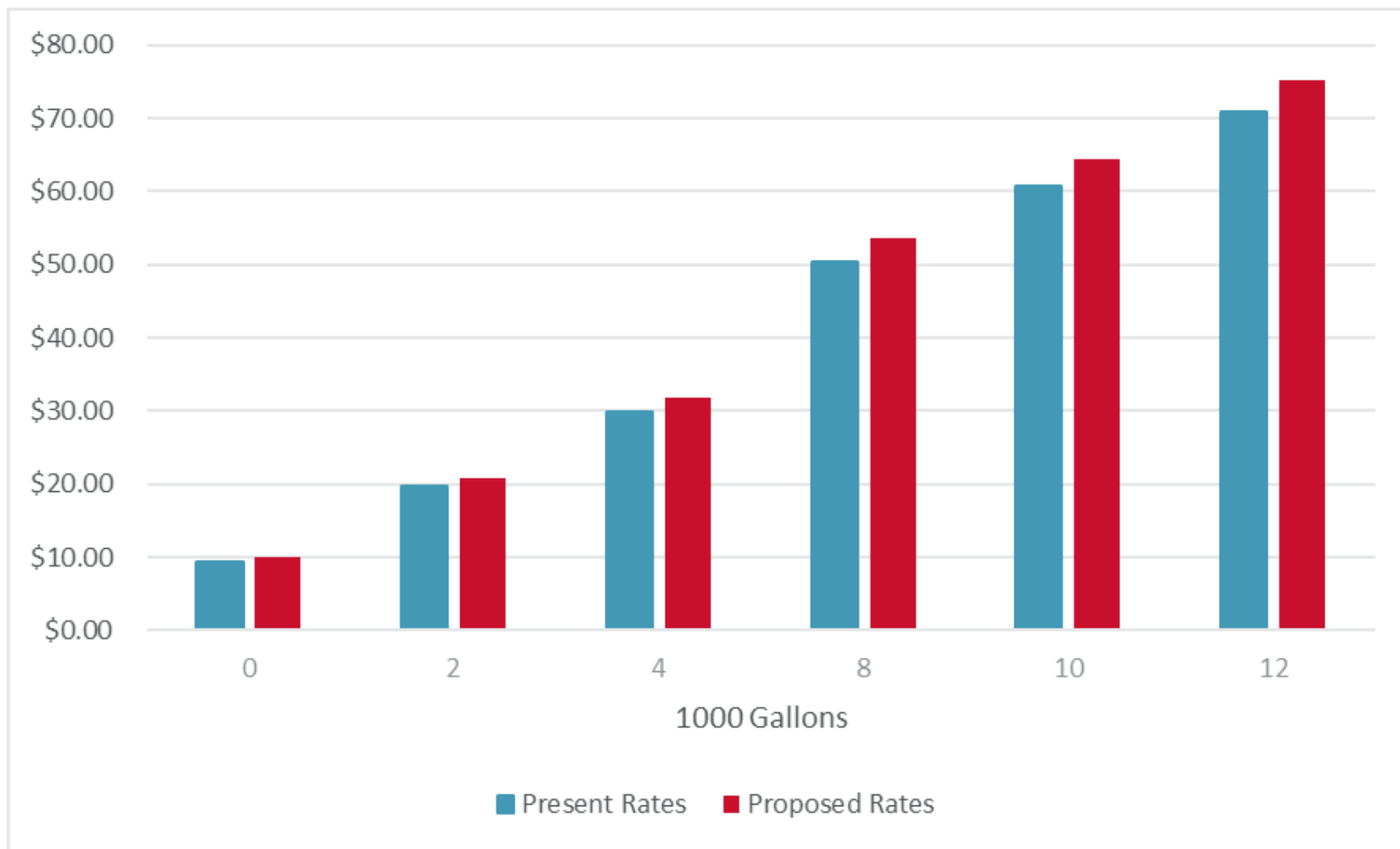



# Local Sewer Bill Comparison

**Sewer Rate Comparison: Single Family Residential  
(Monthly Bill)**

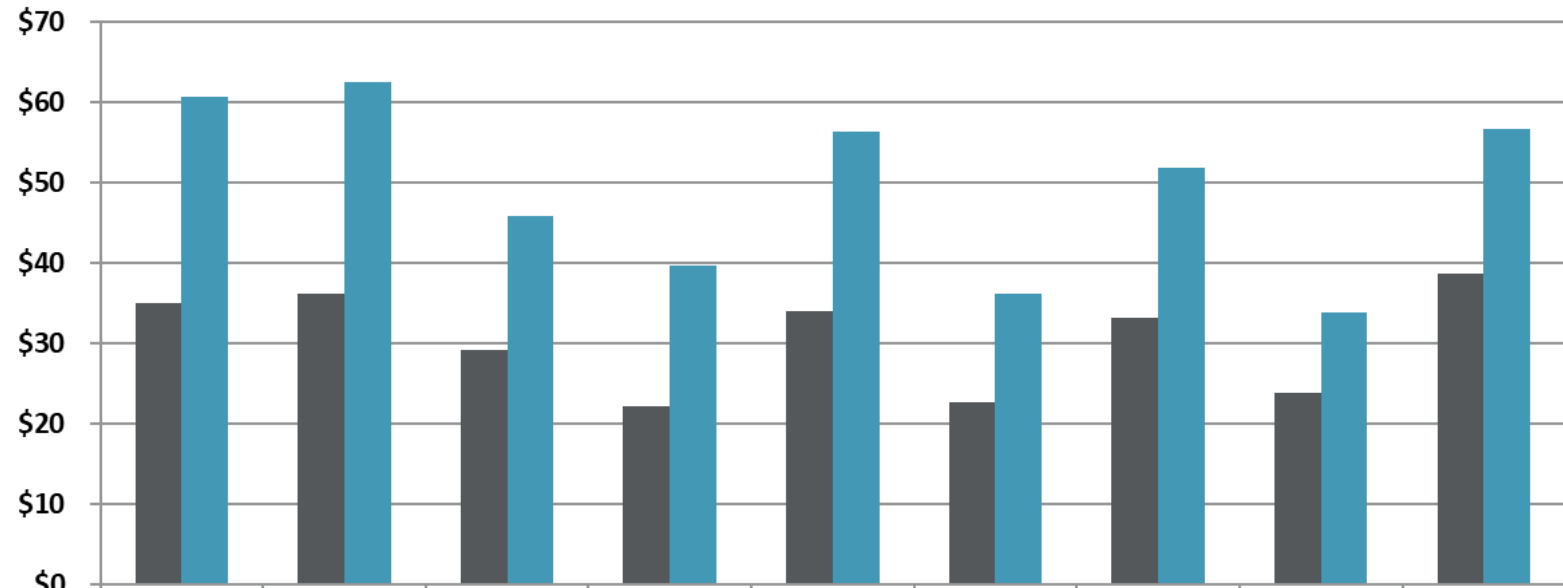

	Present	Proposed (2025)	Average	Kearney	Papillion	North Platte	Hastings	Fremont	Norfolk
	City of Columbus								
■ 5,000 gal	\$35.06	\$36.11	\$29.09	\$22.17	\$34.04	\$22.70	\$33.16	\$23.78	\$38.72
■ 10,000 gal	\$60.71	\$62.53	\$45.74	\$39.61	\$56.29	\$36.20	\$51.81	\$33.80	\$56.70



# Summary of the Rate Study

Rate adjustments are necessary

- Support ongoing O&M expenses and inflationary impacts
- Identified water capital improvements

Cost of service shows some cost differences

- First cost of service analysis completed in some time
- Recommend across the board adjustments

Proposed rates support projected O&M and Capital needs

- Maintained current rate structure
- Only level of the rates was adjusted



# Questions and Discussion

HDR



# Water Revenue Requirement

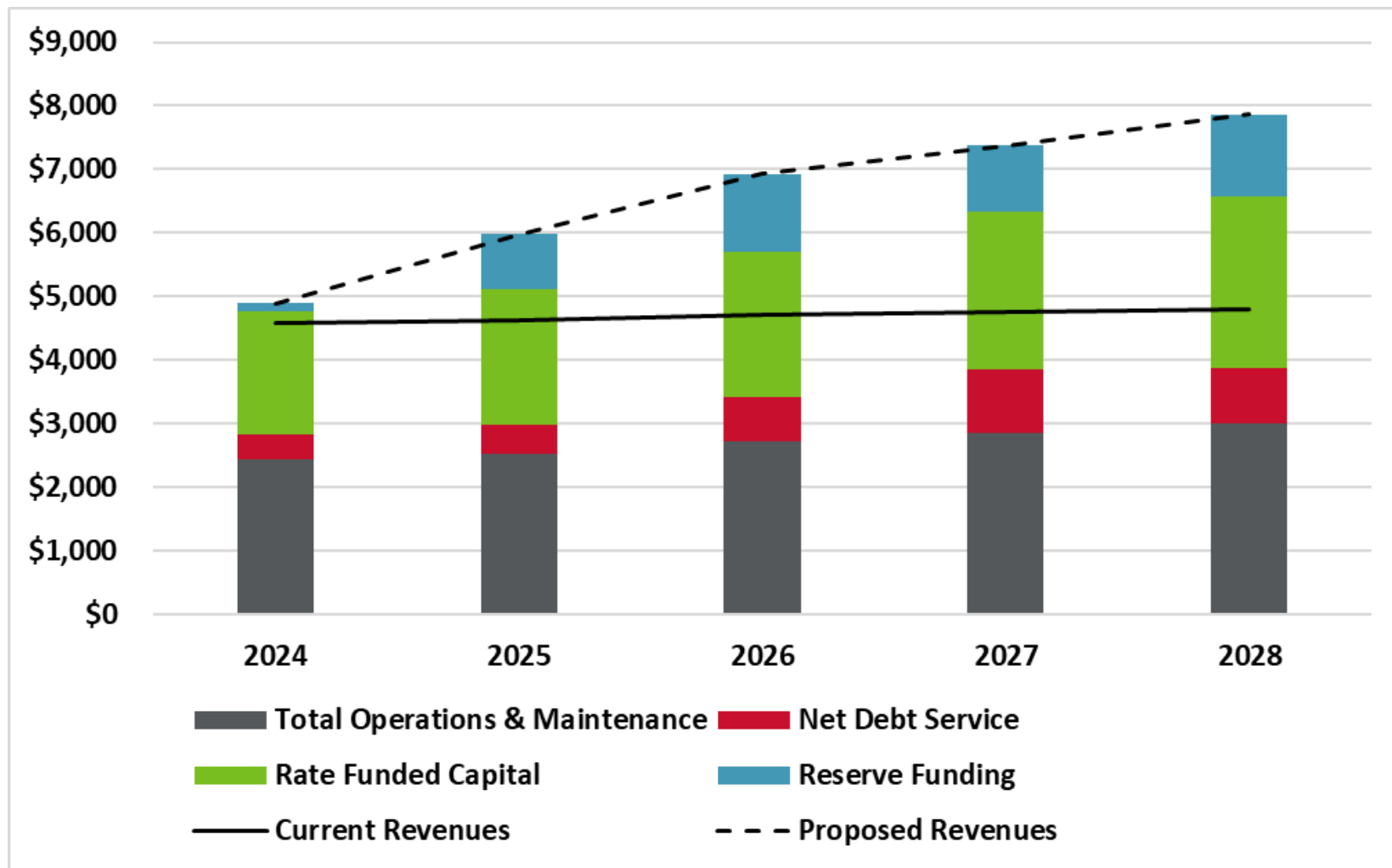

Revenue requirement reflects "Upfront Rate Alt"



# Water Ending Reserves Upfront Alt

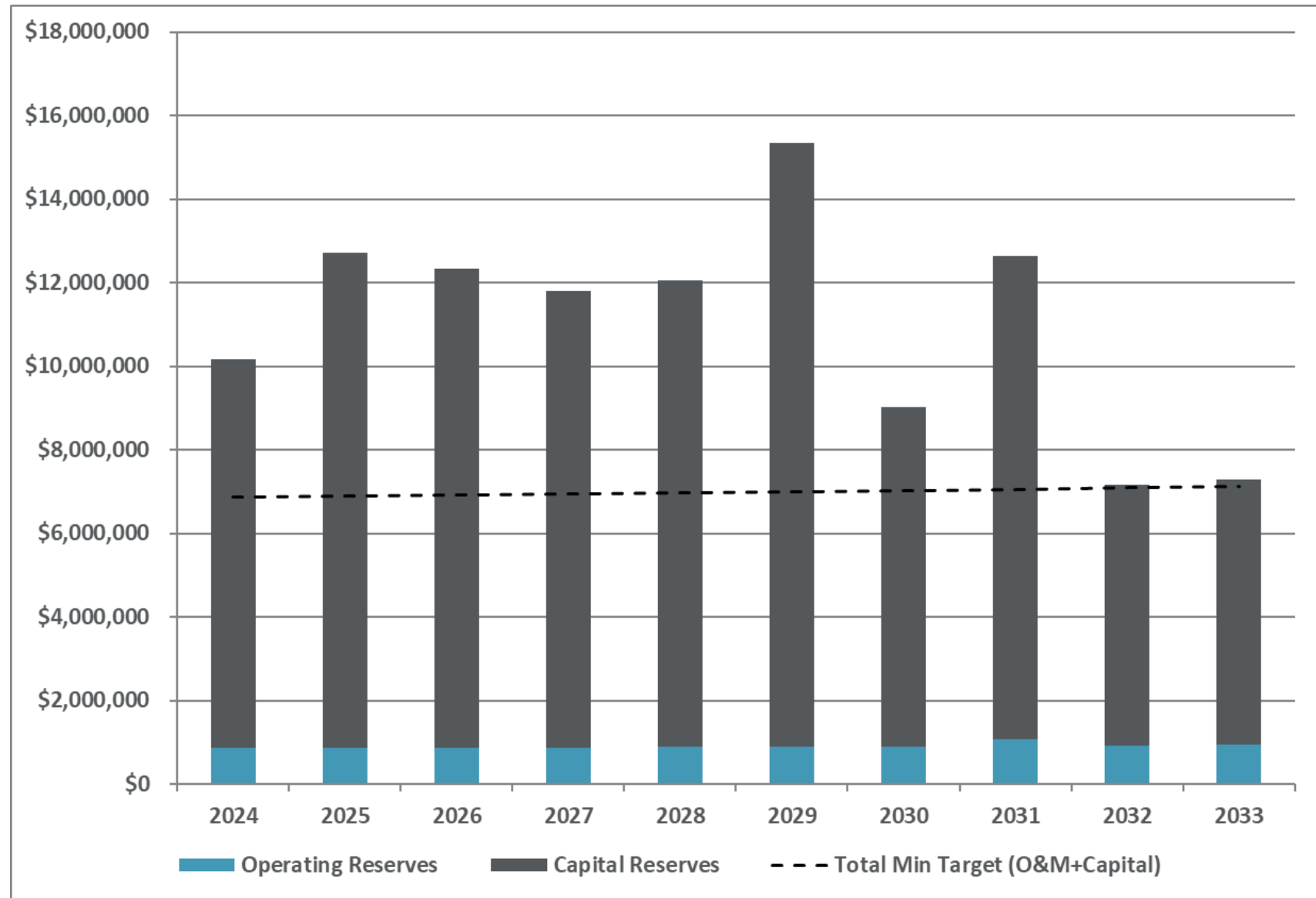

Minimum Target = 90 days of O&M + 1-year of CIP less Debt Funded



# Proposed Commercial Water Rates

	<i>Present Rates</i>	<i>Proposed Rates Alt 1</i>				
		<b>2024</b>	<b>2025</b>	<b>2026</b>	<b>2027</b>	<b>2028</b>
<b>Percent Change</b>		9.5%	9.5%	9.5%	9.5%	9.5%
<b>Service Charges</b>	<i>\$ / Mo</i>					
3/4"	\$6.78	\$7.42	\$8.13	\$8.90	\$9.75	\$10.67
1"	6.78	7.42	8.13	8.90	9.75	10.67
1-1/2"	20.35	22.28	24.40	26.72	29.26	32.04
2"	33.92	37.14	40.67	44.53	48.77	53.40
3"	67.85	74.30	81.35	89.08	97.55	106.81
4"	101.77	111.44	122.02	133.62	146.31	160.21
6"	203.54	222.88	244.05	267.23	292.62	320.42
8"	339.24	371.47	406.76	445.40	487.71	534.04
10"	508.86	557.20	610.14	668.10	731.57	801.07
12"	949.86	1,040.10	1,138.91	1,247.10	1,365.58	1,495.31
<b>Consumption Charge Inside</b>	<i>\$ / 1000</i>					
All Consumption	\$1.21	\$1.32	\$1.45	\$1.59	\$1.74	\$1.90
<b>Consumption Charge Outside</b>	<i>\$ / 1000</i>					
All Consumption	2.63	\$2.88	\$3.15	\$3.45	\$3.78	\$4.14



# Proposed Industrial Water Rates

	<i>Present Rates</i>	<i>Proposed Rates Alt 1</i>				
		<b>2024</b>	<b>2025</b>	<b>2026</b>	<b>2027</b>	<b>2028</b>
<b>Percent Change</b>		9.5%	9.5%	9.5%	9.5%	9.5%
<b>Service Charges</b>	<i>\$ / Mo</i>					
3/4"	\$6.78	\$7.42	\$8.13	\$8.90	\$9.75	\$10.67
1"	6.78	7.42	8.13	8.90	9.75	10.67
1-1/2"	20.35	22.28	24.40	26.72	29.26	32.04
2"	33.92	37.14	40.67	44.53	48.77	53.40
3"	67.85	74.30	81.35	89.08	97.55	106.81
4"	101.77	111.44	122.02	133.62	146.31	160.21
6"	203.54	222.88	244.05	267.23	292.62	320.42
8"	339.24	371.47	406.76	445.40	487.71	534.04
10"	508.86	557.20	610.14	668.10	731.57	801.07
12"	949.86	1,040.10	1,138.91	1,247.10	1,365.58	1,495.31
<b>Consumption Charge Inside</b>	<i>\$ / 1000</i>					
All Consumption	\$1.19	\$1.30	\$1.43	\$1.56	\$1.71	\$1.87
<b>Consumption Charge Outside</b>	<i>\$ / 1000</i>					
All Consumption	\$2.47	\$2.70	\$2.96	\$3.24	\$3.55	\$3.89



# Columbus Water Rate Alternatives

	2023	2024	2025	2026	2027	2028
<b>Alt 1 – Implementation of Full CIP Including Manganese Treatment</b>						
Percent Change	--	19.5%	19.5%	19.5%	12.0%	6.5%
Avg Customer Bill <sup>1</sup>	\$20.28	\$24.23	\$28.96	\$34.61	\$38.76	\$41.28
Monthly Change	--	\$3.95	\$4.73	\$5.65	\$4.15	\$2.52
<b>Current Proposed</b>						
Percent Change	--	9.5%	9.5%	9.5%	9.5%	9.5%
Avg Customer Bill <sup>2</sup>	\$35.06	\$36.11	\$37.20	\$38.31	\$39.46	\$40.64
Monthly Change	--	\$1.05	\$1.08	\$1.12	\$1.15	\$1.18
1 – ¾ Meter Billing Charge + 10,000 Gal 2 – ¾ Meter Billing Charge + 5,000 Gal						



# 2025 Residential Monthly Water Bill, Upfront

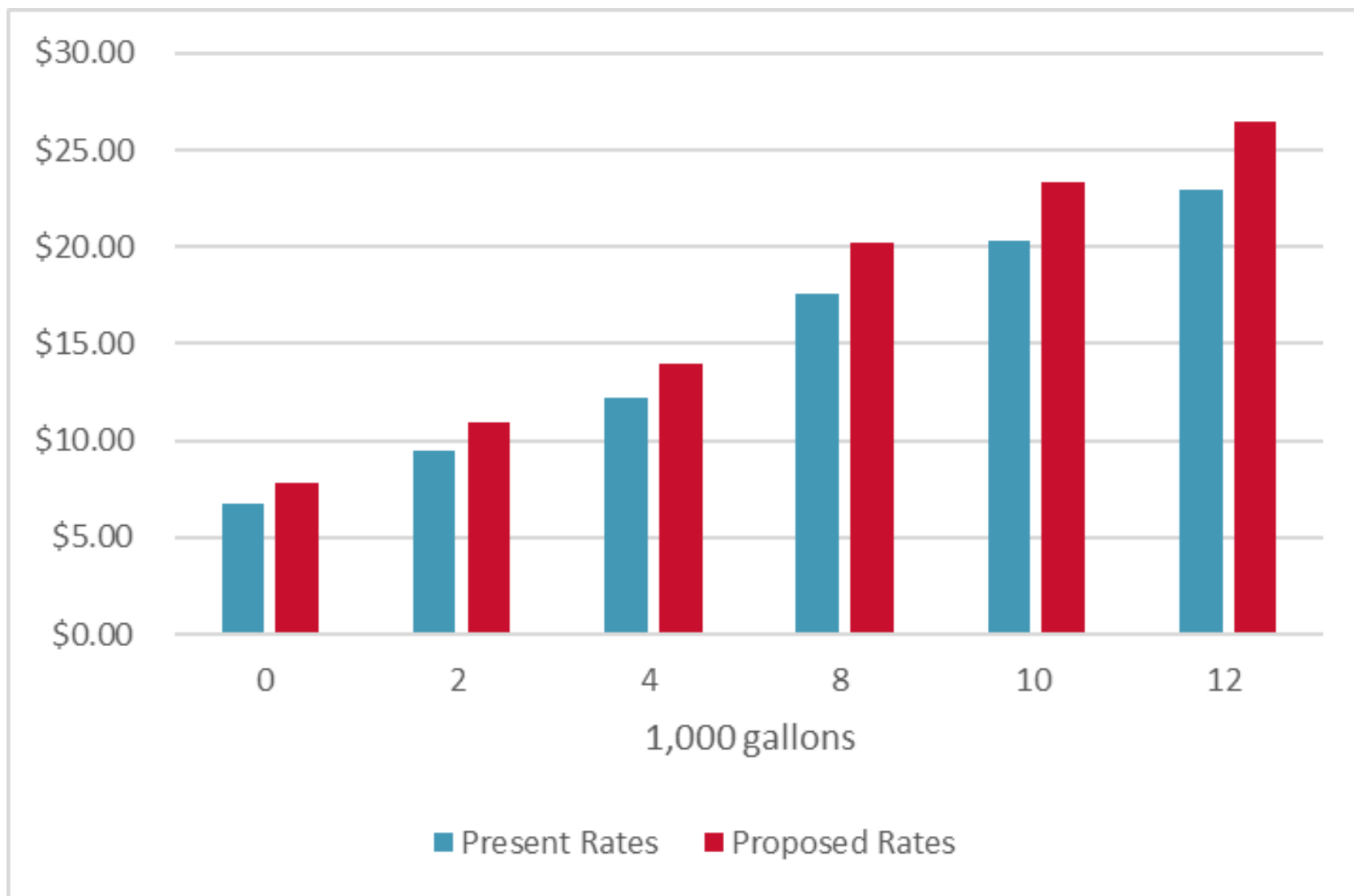

#### **4. Adjournment.**