

City Council Regular Meeting
Tuesday, September 5, 2023 6:00 PM
Columbus Community Building/Community Room
2500 14 Street
Columbus, NE 68601

The Mayor and City Council reserve the right to go into closed session as per Section 84-1410 of the Nebraska Revised Statutes. A current agenda is on file at City Hall, 2500 14 Street, Columbus, Nebraska. For more information, call 402-562-4224 or visit our website at www.columbusne.us.

{{Name: Agenda Item Name}}

**1. STATEMENT OF COMPLIANCE WITH OPEN MEETINGS ACT AND ROLL
CALL**

NEBRASKA OPEN MEETINGS ACT

84-1407. Act, how cited.

Sections 84-1407 to 84-1414 shall be known and may be cited as the Open Meetings Act.

Source: Laws 2004, LB 821, § 34.

84-1408. Declaration of intent; meetings open to public.

It is hereby declared to be the policy of this state that the formation of public policy is public business and may not be conducted in secret.

Every meeting of a public body shall be open to the public in order that citizens may exercise their democratic privilege of attending and speaking at meetings of public bodies, except as otherwise provided by the Constitution of Nebraska, federal statutes, and the Open Meetings Act.

Source: Laws 1975, LB 325, § 1; Laws 1996, LB 900, § 1071; Laws 2004, LB 821, § 35.

Annotations

- Nebraska's public meetings laws do not apply to school board deliberations pertaining solely to disputed adjudicative facts. *McQuinn v. Douglas Cty. Sch. Dist. No. 66*, 259 Neb. 720, 612 N.W.2d 198 (2000).
- The primary purpose of the public meetings law is to ensure that public policy is formulated at open meetings. *Marks v. Judicial Nominating Comm.*, 236 Neb. 429, 461 N.W.2d 551 (1990).
- The public meetings law is broadly interpreted and liberally construed to obtain the objective of openness in favor of the public, and provisions permitting closed sessions must be narrowly and strictly construed. *Grein v. Board of Education of Fremont*, 216 Neb. 158, 343 N.W.2d 718 (1984).
- Although a committee was a subcommittee of a natural resources district board, it was not subject to the Open Meetings Act because there was never a quorum of board members in attendance and the committee did not hold hearings, make policy, or take formal action on behalf of the board. *Koch v. Lower Loup NRD*, 27 Neb. App. 301, 931 N.W.2d 160 (2019).
- A county board of equalization is a public body whose meetings shall be open to the public. *Wolf v. Grubbs*, 17 Neb. App. 292, 759 N.W.2d 499 (2009).

84-1409. Terms, defined.

For purposes of the Open Meetings Act, unless the context otherwise requires:

(1)(a) Public body means (i) governing bodies of all political subdivisions of the State of Nebraska, (ii) governing bodies of all agencies, created by the Constitution of Nebraska, statute, or otherwise pursuant to law, of the executive department of the State of Nebraska, (iii) all independent boards, commissions, bureaus, committees, councils, subunits, or any other bodies created by the Constitution of Nebraska, statute, or otherwise pursuant to law, (iv) all study or advisory committees of the executive department of the State of Nebraska whether having continuing existence or appointed as special committees with limited existence, (v) advisory committees of the bodies referred to in subdivisions (i), (ii), and (iii) of this subdivision, and (vi) instrumentalities exercising essentially public functions; and

(b) Public body does not include (i) subcommittees of such bodies unless a quorum of the public body attends a subcommittee meeting or unless such subcommittees are holding hearings, making policy, or taking formal action on behalf of their parent body, except that all meetings of any subcommittee established under section 81-15,175 are subject to the Open Meetings Act, (ii) entities conducting judicial proceedings unless a court or other judicial body is exercising rulemaking authority, deliberating, or deciding upon the issuance of administrative orders, and (iii) the Judicial Resources Commission or subcommittees or subgroups of the commission;

(2) Meeting means all regular, special, or called meetings, formal or informal, of any public body for the purposes of briefing, discussion of public business, formation of tentative policy, or the taking of any action of the public body; and

(3) Virtual conferencing means conducting or participating in a meeting electronically or telephonically with interaction among the participants subject to subsection (2) of section 84-1412.

Source: Laws 1975, LB 325, § 2; Laws 1983, LB 43, § 1; Laws 1989, LB 429, § 42; Laws 1989, LB 311, § 14; Laws 1992, LB 1019, § 124; Laws 1993, LB 635, § 1; Laws 1996, LB 1044, § 978; Laws 1997, LB 798, § 37; Laws 2004, LB 821, § 36; Laws 2007, LB296, § 810; Laws 2011, LB366, § 2; Laws 2021, LB83, § 11; Laws 2022, LB922, § 12.

Operative Date: July 21, 2022

Annotations

- A township is a political subdivision, and as such, a township board is subject to the provisions of the public meetings laws. *Steenblock v. Elkhorn Township Bd.*, 245 Neb. 722, 515 N.W.2d 128 (1994).
- A county agricultural society is a public body to which the provisions of the Nebraska public meetings law are applicable. *Nixon v. Madison Co. Ag. Soc'y*, 217 Neb. 37, 348 N.W.2d 119 (1984).
- Failure by a public governing body, as defined under section 84-1409, R.R.S.1943, to take and record a roll call vote on an action, as required by section 84-1413(2), R.S.Supp.,1980, grants any citizen the right to sue for the purpose of

having the action declared void. In this case such failure could not be later corrected by a nunc pro tunc order because there was no showing that a roll call vote on the disputed action was actually taken, and even if it was the record showed it was not recorded until over a year later. Sections 23-1301, R.R.S.1943, and 23-1302, R.R.S.1943, make it the duty of the county clerk to record proceedings of the board of county commissioners. *State ex rel. Schuler v. Dunbar*, 208 Neb. 69, 302 N.W.2d 674 (1981).

- Although a committee was a subcommittee of a natural resources district board, it was not subject to the Open Meetings Act because there was never a quorum of board members in attendance and the committee did not hold hearings, make policy, or take formal action on behalf of the board. *Koch v. Lower Loup NRD*, 27 Neb. App. 301, 931 N.W.2d 160 (2019).
- Although the Open Meetings Act does not define "subcommittee," a subcommittee is generally defined as a group within a committee to which the committee may refer business. *Koch v. Lower Loup NRD*, 27 Neb. App. 301, 931 N.W.2d 160 (2019).
- The Open Meetings Act does not require policymakers to remain ignorant of the issues they must decide until the moment the public is invited to comment on a proposed policy. By excluding nonquorum subgroups from the definition of a public body, the Legislature has balanced the public's need to be heard on matters of public policy with a practical accommodation for a public body's need for information to conduct business. *Koch v. Lower Loup NRD*, 27 Neb. App. 301, 931 N.W.2d 160 (2019).
- As an administrative agency of the county, a county board of equalization is a public body. *Wolf v. Grubbs*, 17 Neb. App. 292, 759 N.W.2d 499 (2009).
- The electors of a township at their annual meeting are a public body under the Open Meetings Act. *State ex rel. Newman v. Columbus Township Bd.*, 15 Neb. App. 656, 735 N.W.2d 399 (2007).
- The meeting at issue in this case was a "meeting" within the parameters of subsection (2) of this section because it involved the discussion of public business, the formation of tentative policy, or the taking of any action of the public power district. *Hansmeyer v. Nebraska Pub. Power Dist.*, 6 Neb. App. 889, 578 N.W.2d 476 (1998).
- Informational sessions in which the governmental body hears reports are briefings. *Johnson v. Nebraska Environmental Control Council*, 2 Neb. App. 263, 509 N.W.2d 21 (1993).

84-1410. Closed session; when; purpose; reasons listed; procedure; right to challenge; prohibited acts; chance meetings, conventions, or workshops.

(1) Any public body may hold a closed session by the affirmative vote of a majority of its voting members if a closed session is clearly necessary for the protection of the public interest or for the prevention of needless injury to the reputation of an individual and if such individual has not requested a public meeting. The subject matter and the reason necessitating the closed session shall be identified in the motion to close. Closed sessions may be held for, but shall not be limited to, such reasons as:

(a) Strategy sessions with respect to collective bargaining, real estate purchases, pending litigation, or litigation which is imminent as evidenced by communication of a claim or threat of litigation to or by the public body;

(b) Discussion regarding deployment of security personnel or devices;

(c) Investigative proceedings regarding allegations of criminal misconduct;

(d) Evaluation of the job performance of a person when necessary to prevent needless injury to the reputation of a person and if such person has not requested a public meeting;

(e) For the Community Trust created under section 81-1801.02, discussion regarding the amounts to be paid to individuals who have suffered from a tragedy of violence or natural disaster; or

(f) For public hospitals, governing board peer review activities, professional review activities, review and discussion of medical staff investigations or disciplinary actions, and any strategy session concerning transactional negotiations with any referral source that is required by federal law to be conducted at arms length.

Nothing in this section shall permit a closed meeting for discussion of the appointment or election of a new member to any public body.

(2) The vote to hold a closed session shall be taken in open session. The entire motion, the vote of each member on the question of holding a closed session, and the time when the closed session commenced and concluded shall be recorded in the minutes. If the motion to close passes, then the presiding officer immediately prior to the closed session shall restate on the record the limitation of the subject matter of the closed session. The public body holding such a closed session shall restrict its consideration of matters during the closed portions to only those purposes set forth in the motion to close as the reason for the closed session. The meeting shall be reconvened in open session before any formal action may be taken. For purposes of this section, formal action shall mean a collective decision or a collective commitment or promise to make a decision on any question, motion, proposal, resolution, order, or ordinance or formation of a position or policy but shall not include negotiating guidance given by members of the public body to legal counsel or other negotiators in closed sessions authorized under subdivision (1)(a) of this section.

(3) Any member of any public body shall have the right to challenge the continuation of a closed session if the member determines that the session has exceeded the reason stated in the original motion to hold a closed session or if the member contends that the closed session is neither clearly necessary for (a) the protection of the public interest or (b) the prevention of needless injury to the reputation of an individual. Such challenge shall be overruled only by a majority vote of the members of the public body. Such challenge and its disposition shall be recorded in the minutes.

(4) Nothing in this section shall be construed to require that any meeting be closed to the public. No person or public body shall fail to invite a portion of its members to a meeting, and no public body shall designate itself a subcommittee of the whole body for the purpose of circumventing the Open Meetings Act. No closed session, informal meeting, chance meeting, social gathering, email, fax, or other electronic communication shall be used for the purpose of circumventing the requirements of the act.

(5) The act does not apply to chance meetings or to attendance at or travel to conventions or workshops of members of a public body at which there is no meeting of the body then intentionally convened, if there is no vote or other action taken regarding any matter over which the public body has supervision, control, jurisdiction, or advisory power.

Source: Laws 1975, LB 325, § 3; Laws 1983, LB 43, § 2; Laws 1985, LB 117, § 1; Laws 1992, LB 1019, § 125; Laws 1994, LB 621, § 1; Laws 1996, LB 900, § 1072; Laws 2004, LB 821, § 37; Laws 2004, LB 1179, § 1; Laws 2006, LB 898, § 1; Laws 2011, LB390, § 29; Laws 2012, LB995, § 17.

Annotations

- There is no absolute discovery privilege for communications that occur during a closed session. *State ex rel. Upper Republican NRD v. District Judges*, 273 Neb. 148, 728 N.W.2d 275 (2007).
- If a person present at a meeting observes a public meetings law violation in the form of an improper closed session and fails to object, that person waives his or her right to object at a later date. *Wasikowski v. Nebraska Quality Jobs Bd.*, 264 Neb. 403, 648 N.W.2d 756 (2002).
- The public interest mentioned in this section is that shared by citizens in general and by the community at large concerning pecuniary or legal rights and liabilities. *Grein v. Board of Education*, 216 Neb. 158, 343 N.W.2d 718 (1984).
- Hearing in closed executive session was contrary to this section since there was no showing of necessity or reason under subdivision (1)(a), (b), or (c), but did not result in reversal of board decision. *Simonds v. Board of Examiners*, 213 Neb. 259, 329 N.W.2d 92 (1983).
- Negotiations for the purchase of land need not be conducted at an open meeting but the deliberations of a city council as to whether an offer to purchase real estate

should be made should take place in an open meeting. *Pokorny v. City of Schuyler*, 202 Neb. 334, 275 N.W.2d 281 (1979).

- Public meeting law was not violated where the Board of Regents of the University of Nebraska voted to hold a closed session to consider the university president's resignation, and also discussed the appointment of an interim president during such session. *Meyer v. Board of Regents*, 1 Neb. App. 893, 510 N.W.2d 450 (1993).

84-1411. Meetings of public body; notice; method; contents; when available; right to modify; duties concerning notice; virtual conferencing authorized; requirements; emergency meeting without notice; appearance before public body.

(1)(a) Each public body shall give reasonable advance publicized notice of the time and place of each meeting as provided in this subsection. Such notice shall be transmitted to all members of the public body and to the public.

(b)(i) Except as provided in subdivision (1)(b)(ii) of this section, in the case of a public body described in subdivision (1)(a)(i) of section 84-1409 or such body's advisory committee, such notice shall be published in a newspaper of general circulation within the public body's jurisdiction and, if available, on such newspaper's website.

(ii) In the case of the governing body of a city of the second class or village or such body's advisory committee, such notice shall be published by:

(A) Publication in a newspaper of general circulation within the public body's jurisdiction and, if available, on such newspaper's website; or

(B) Posting written notice in three conspicuous public places in such city or village. Such notice shall be posted in the same three places for each meeting.

(iii) In the case of a public body not described in subdivision (1)(b)(i) or (ii) of this section, such notice shall be given by a method designated by the public body.

(c) In addition to a method of notice required by subdivision (1)(b)(i) or (ii) of this section, such notice may also be provided by any other appropriate method designated by such public body or such advisory committee.

(d) Each public body shall record the methods and dates of such notice in its minutes.

(e) Such notice shall contain an agenda of subjects known at the time of the publicized notice or a statement that the agenda, which shall be kept continually current, shall be readily available for public inspection at the principal office of the public body during normal business hours. Agenda items shall be sufficiently descriptive to give the public reasonable notice of the matters to be considered at the meeting. Except for items of an emergency nature, the agenda shall not be altered later than (i) twenty-four hours before the scheduled commencement of the meeting or

(ii) forty-eight hours before the scheduled commencement of a meeting of a city council or village board scheduled outside the corporate limits of the municipality. The public body shall have the right to modify the agenda to include items of an emergency nature only at such public meeting.

(2)(a) The following entities may hold a meeting by means of virtual conferencing if the requirements of subdivision (2)(b) of this section are met:

(i) A state agency, state board, state commission, state council, or state committee, or an advisory committee of any such state entity;

(ii) An organization, including the governing body, created under the Interlocal Cooperation Act, the Joint Public Agency Act, or the Municipal Cooperative Financing Act;

(iii) The governing body of a public power district having a chartered territory of more than one county in this state;

(iv) The governing body of a public power and irrigation district having a chartered territory of more than one county in this state;

(v) An educational service unit;

(vi) The Educational Service Unit Coordinating Council;

(vii) An organization, including the governing body, of a risk management pool or its advisory committees organized in accordance with the Intergovernmental Risk Management Act;

(viii) A community college board of governors;

(ix) The Nebraska Brand Committee;

(x) A local public health department;

(xi) A metropolitan utilities district;

(xii) A regional metropolitan transit authority; and

(xiii) A natural resources district.

(b) The requirements for holding a meeting by means of virtual conferencing are as follows:

(i) Reasonable advance publicized notice is given as provided in subsection (1) of this section, including providing access to a dial-in number or link to the virtual conference;

(ii) In addition to the public's right to participate by virtual conferencing, reasonable arrangements are made to accommodate the public's right to attend at a physical site and participate as provided in section 84-1412, including reasonable seating, in at least one designated site in a building open to the public and identified in the notice, with: At least one member of the entity holding such meeting, or his or her designee, present at each site; a

recording of the hearing by audio or visual recording devices; and a reasonable opportunity for input, such as public comment or questions, is provided to at least the same extent as would be provided if virtual conferencing was not used;

(iii) At least one copy of all documents being considered at the meeting is available at any physical site open to the public where individuals may attend the virtual conference. The public body shall also provide links to an electronic copy of the agenda, all documents being considered at the meeting, and the current version of the Open Meetings Act; and

(iv) Except as otherwise provided in this subdivision or subsection (4) of section 79-2204, no more than one-half of the meetings of the state entities, advisory committees, boards, councils, organizations, or governing bodies are held by virtual conferencing in a calendar year. In the case of an organization created under the Interlocal Cooperation Act that sells electricity or natural gas at wholesale on a multistate basis or an organization created under the Municipal Cooperative Financing Act, the organization may hold more than one-half of its meetings by virtual conferencing if such organization holds at least one meeting each calendar year that is not by virtual conferencing. The governing body of a risk management pool that meets at least quarterly and the advisory committees of the governing body may each hold more than one-half of its meetings by virtual conferencing if the governing body's quarterly meetings are not held by virtual conferencing.

(3) Virtual conferencing, emails, faxes, or other electronic communication shall not be used to circumvent any of the public government purposes established in the Open Meetings Act.

(4) The secretary or other designee of each public body shall maintain a list of the news media requesting notification of meetings and shall make reasonable efforts to provide advance notification to them of the time and place of each meeting and the subjects to be discussed at that meeting.

(5) When it is necessary to hold an emergency meeting without reasonable advance public notice, the nature of the emergency shall be stated in the minutes and any formal action taken in such meeting shall pertain only to the emergency. Such emergency meetings may be held by virtual conferencing. The provisions of subsection (4) of this section shall be complied with in conducting emergency meetings. Complete minutes of such emergency meetings specifying the nature of the emergency and any formal action taken at the meeting shall be made available to the public by no later than the end of the next regular business day.

(6) A public body may allow a member of the public or any other witness to appear before the public body by means of virtual conferencing.

(7)(a) Notwithstanding subsections (2) and (5) of this section, if an emergency is declared by the Governor pursuant to the Emergency Management Act as defined in section 81-829.39, a public body the territorial jurisdiction of which is included in the emergency declaration, in whole or in part, may hold a meeting by virtual conferencing during such emergency if the

public body gives reasonable advance publicized notice as described in subsection (1) of this section. The notice shall include information regarding access for the public and news media. In addition to any formal action taken pertaining to the emergency, the public body may hold such meeting for the purpose of briefing, discussion of public business, formation of tentative policy, or the taking of any action by the public body.

(b) The public body shall provide access by providing a dial-in number or a link to the virtual conference. The public body shall also provide links to an electronic copy of the agenda, all documents being considered at the meeting, and the current version of the Open Meetings Act. Reasonable arrangements shall be made to accommodate the public's right to hear and speak at the meeting and record the meeting. Subsection (4) of this section shall be complied with in conducting such meetings.

(c) The nature of the emergency shall be stated in the minutes. Complete minutes of such meeting specifying the nature of the emergency and any formal action taken at the meeting shall be made available for inspection as provided in subsection (5) of section 84-1413.

(8) In addition to any other statutory authorization for virtual conferencing, any public body not listed in subdivision (2)(a) of this section may hold a meeting by virtual conferencing if:

(a) The purpose of the virtual meeting is to discuss items that are scheduled to be discussed or acted upon at a subsequent non-virtual open meeting of the public body;

(b) No action is taken by the public body at the virtual meeting; and

(c) The public body complies with subdivisions (2)(b)(i) and (2)(b)(ii) of this section.

Source: Laws 1975, LB 325, § 4; Laws 1983, LB 43, § 3; Laws 1987, LB 663, § 25; Laws 1993, LB 635, § 2; Laws 1996, LB 469, § 6; Laws 1996, LB 1161, § 1; Laws 1999, LB 47, § 2; Laws 1999, LB 87, § 100; Laws 1999, LB 461, § 1; Laws 2000, LB 968, § 85; Laws 2004, LB 821, § 38; Laws 2004, LB 1179, § 2; Laws 2006, LB 898, § 2; Laws 2007, LB199, § 9; Laws 2009, LB361, § 2; Laws 2012, LB735, § 1; Laws 2013, LB510, § 1; Laws 2017, LB318, § 1; Laws 2019, LB212, § 5; Laws 2020, LB148, § 3; Laws 2021, LB83, § 12; Laws 2022, LB742, § 1; Laws 2022, LB908, § 1; Laws 2022, LB922, § 13.

Note: The Revisor of Statutes has pursuant to section 49-769 correlated LB742, section 1, with LB908, section 1, and LB922, section 13, to reflect all amendments.

Note: Changes made by LB742 and LB908 became effective July 21, 2022. Changes made by LB922 became operative July 21, 2022.

Cross References

- **Intergovernmental Risk Management Act**, see section 44-4301.
- **Interlocal Cooperation Act**, see section 13-801.
- **Joint Public Agency Act**, see section 13-2501.

- **Municipal Cooperative Financing Act**, see section 18-2401.

Annotations

- Under subsection (1) of this section, the Legislature has imposed only two conditions on the public body's notification method of a public meeting: (1) It must give reasonable advance publicized notice of the time and place of each meeting and (2) it must be recorded in the public body's minutes. *City of Elkhorn v. City of Omaha*, 272 Neb. 867, 725 N.W.2d 792 (2007).
- An emergency is "(a)ny event or occasional combination of circumstances which calls for immediate action or remedy; pressing necessity; exigency; a sudden or unexpected happening; an unforeseen occurrence or condition." *Steenblock v. Elkhorn Township Bd.*, 245 Neb. 722, 515 N.W.2d 128 (1994).
- An agenda which gives reasonable notice of the matters to be considered at a meeting of a city council complies with the requirements of this section. *Pokorny v. City of Schuyler*, 202 Neb. 334, 275 N.W.2d 281 (1979).
- When notice is required, a notice of a special meeting of a city council posted in three public places at 10:00 p.m. on the day preceding the meeting is not reasonable advance publicized notice of a meeting as is required by this section. *Pokorny v. City of Schuyler*, 202 Neb. 334, 275 N.W.2d 281 (1979).
- Teacher waived right to object to lack of public notice in board of education employment hearing by voluntary participation in the hearing without objection. *Alexander v. School Dist. No. 17*, 197 Neb. 251, 248 N.W.2d 335 (1976).
- A county board of commissioners and a county board of equalization are not required to give separate notices when the notice states only the time and place that the boards meet and directs a citizen to where the agendas for each board can be found. *Wolf v. Grubbs*, 17 Neb. App. 292, 759 N.W.2d 499 (2009).
- A county board of equalization is a public body which is required to give advanced publicized notice of its meetings. *Wolf v. Grubbs*, 17 Neb. App. 292, 759 N.W.2d 499 (2009).
- Notice of recessed and reconvened meetings must be given in the same fashion as the original meeting. *Wolf v. Grubbs*, 17 Neb. App. 292, 759 N.W.2d 499 (2009).
- True notice of a meeting is not given by burying such in the minutes of a prior board proceeding. *Wolf v. Grubbs*, 17 Neb. App. 292, 759 N.W.2d 499 (2009).
- An agenda notice which merely stated "work order reports" was an inadequate notice under this section because it did not give interested persons knowledge that plans for a 345 kv transmission line through the district was going to be discussed and voted upon at the meeting. Inadequate agenda notice under this section meant there was a substantial violation of the public meeting laws; however, later actions by the board of directors cured the defects in notice, and such actions were in substantial compliance with the statute. *Hansmeyer v. Nebraska Pub. Power Dist.*, 6 Neb. App. 889, 578 N.W.2d 476 (1998).

84-1412. Meetings of public body; rights of public; public body; powers and duties.

(1) Subject to the Open Meetings Act, the public has the right to attend and the right to speak at meetings of public bodies, and all or any part of a meeting of a public body, except for closed sessions called pursuant to section 84-1410, may be videotaped, televised, photographed, broadcast, or recorded by any person in attendance by means of a tape recorder, a camera, video equipment, or any other means of pictorial or sonic reproduction or in writing.

(2) It shall not be a violation of subsection (1) of this section for any public body to make and enforce reasonable rules and regulations regarding the conduct of persons attending, speaking at, videotaping, televising, photographing, broadcasting, or recording its meetings, including meetings held by virtual conferencing. A body may not be required to allow citizens to speak at each meeting, but it may not forbid public participation at all meetings.

(3) No public body shall require members of the public to identify themselves as a condition for admission to the meeting nor shall such body require that the name of any member of the public be placed on the agenda prior to such meeting in order to speak about items on the agenda. The body shall require any member of the public desiring to address the body to identify himself or herself, including an address and the name of any organization represented by such person unless the address requirement is waived to protect the security of the individual.

(4) No public body shall, for the purpose of circumventing the Open Meetings Act, hold a meeting in a place known by the body to be too small to accommodate the anticipated audience.

(5) No public body shall be deemed in violation of this section if it holds its meeting in its traditional meeting place which is located in this state.

(6) No public body shall be deemed in violation of this section if it holds a meeting outside of this state if, but only if:

(a) A member entity of the public body is located outside of this state and the meeting is in that member's jurisdiction;

(b) All out-of-state locations identified in the notice are located within public buildings used by members of the entity or at a place which will accommodate the anticipated audience;

(c) Reasonable arrangements are made to accommodate the public's right to attend, hear, and speak at the meeting, including making virtual conferencing available at an in-state location to members, the public, or the press, if requested twenty-four hours in advance;

(d) No more than twenty-five percent of the public body's meetings in a calendar year are held out-of-state;

(e) Out-of-state meetings are not used to circumvent any of the public government purposes established in the Open Meetings Act; and

(f) The public body publishes notice of the out-of-state meeting at least twenty-one days before the date of the meeting in a legal newspaper of statewide circulation.

(7) Each public body shall, upon request, make a reasonable effort to accommodate the public's right to hear the discussion and testimony presented at a meeting.

(8) Public bodies shall make available at the meeting or the instate location for virtual conferencing as required by subdivision (6)(c) of this section, for examination and copying by members of the public, at least one copy of all reproducible written material to be discussed at an open meeting, either in paper or electronic form. Public bodies shall make available at least one current copy of the Open Meetings Act posted in the meeting room at a location accessible to members of the public. At the beginning of the meeting, the public shall be informed about the location of the posted information.

Source: Laws 1975, LB 325, § 5; Laws 1983, LB 43, § 4; Laws 1985, LB 117, § 2; Laws 1987, LB 324, § 5; Laws 1996, LB 900, § 1073; Laws 2001, LB 250, § 2; Laws 2004, LB 821, § 39; Laws 2006, LB 898, § 3; Laws 2008, LB962, § 1; Laws 2021, LB83, § 13.

Annotations

- To preserve an objection that a public body failed to make documents available at a public meeting as required by subsection (8) of this section, a person who attends a public meeting must not only object to the violation, but must make that objection to the public body or to a member of the public body. *Stoetzel & Sons v. City of Hastings*, 265 Neb. 637, 658 N.W.2d 636 (2003).

84-1413. Meetings; minutes; roll call vote; secret ballot; when; agenda and minutes; required on website; when.

(1) Each public body shall keep minutes of all meetings showing the time, place, members present and absent, and the substance of all matters discussed.

(2) Any action taken on any question or motion duly moved and seconded shall be by roll call vote of the public body in open session, and the record shall state how each member voted or if the member was absent or not voting. The requirements of a roll call or viva voce vote shall be satisfied by a public body which utilizes an electronic voting device which allows the yeas and nays of each member of such public body to be readily seen by the public.

(3) The vote to elect leadership within a public body may be taken by secret ballot, but the total number of votes for each candidate shall be recorded in the minutes.

(4) The minutes of all meetings and evidence and documentation received or disclosed in open session shall be public records and open to public inspection during normal business hours.

(5) Minutes shall be written or kept as an electronic record and shall be available for inspection within ten working days or prior to the next convened meeting, whichever occurs

earlier, except that cities of the second class and villages may have an additional ten working days if the employee responsible for writing or keeping the minutes is absent due to a serious illness or emergency.

(6) Beginning July 31, 2022, the governing body of a natural resources district, the city council of a city of the metropolitan class, the city council of a city of the primary class, the city council of a city of the first class, the county board of a county with a population greater than twenty-five thousand inhabitants, and the school board of a school district shall make available on such entity's public website the agenda and minutes of any meeting of the governing body. The agenda shall be placed on the website at least twenty-four hours before the meeting of the governing body. Minutes shall be placed on the website at such time as the minutes are available for inspection as provided in subsection (5) of this section. This information shall be available on the public website for at least six months.

Source: Laws 1975, LB 325, § 6; Laws 1978, LB 609, § 3; Laws 1979, LB 86, § 9; Laws 1987, LB 663, § 26; Laws 2005, LB 501, § 1; Laws 2009, LB361, § 3; Laws 2015, LB365, § 2; Laws 2016, LB876, § 1; Laws 2021, LB83, § 14; Laws 2022, LB742, § 2.

Effective Date: July 21, 2022

Annotations

- If a person present at a meeting observes and fails to object to an alleged public meetings laws violation in the form of a failure to conduct rollcall votes before taking actions on questions or motions pending, that person waives his or her right to object at a later date. *Hauser v. Nebraska Police Stds. Adv. Council*, 264 Neb. 944, 653 N.W.2d 240 (2002).
- Subsection (2) of this section does not require the record to state that the vote was by roll call, but requires only that the record show if and how each member voted. Neither does the statute set a time limit for recording the results of a vote, after which no corrections of the record can be made. If no intervening rights of third persons have arisen, a board of county commissioners has power to correct the record of the proceedings had at a previous meeting so as to make them speak the truth, particularly where the correction supplies some omitted fact or action and is done not to contradict or change the original record but to have the record show that a certain action was taken or thing done, which the original record fails to show. *State ex rel. Schuler v. Dunbar*, 214 Neb. 85, 333 N.W.2d 652 (1983).
- Failure by a public governing body, as defined under section 84-1409, R.R.S.1943, to take and record a roll call vote on an action, as required by section 84-1413(2), R.S.Supp.,1980, grants any citizen the right to sue for the purpose of having the action declared void. In this case such failure could not be later corrected by a nunc pro tunc order because there was no showing that a roll call vote on the disputed action was actually taken, and even if it was the record showed it was not recorded until over a year later. Sections 23-1301, R.R.S.1943,

and 23-1302, R.R.S.1943, make it the duty of the county clerk to record proceedings of the board of county commissioners. *State ex rel. Schuler v. Dunbar*, 208 Neb. 69, 302 N.W.2d 674 (1981).

- There is no requirement that a public body make a record of where notice was published or posted. *Wolf v. Grubbs*, 17 Neb. App. 292, 759 N.W.2d 499 (2009).

84-1414. Unlawful action by public body; declared void or voidable by district court; when; duty to enforce open meeting laws; citizen's suit; procedure; violations; penalties.

(1) Any motion, resolution, rule, regulation, ordinance, or formal action of a public body made or taken in violation of the Open Meetings Act shall be declared void by the district court if the suit is commenced within one hundred twenty days of the meeting of the public body at which the alleged violation occurred. Any motion, resolution, rule, regulation, ordinance, or formal action of a public body made or taken in substantial violation of the Open Meetings Act shall be voidable by the district court if the suit is commenced more than one hundred twenty days after but within one year of the meeting of the public body in which the alleged violation occurred. A suit to void any final action shall be commenced within one year of the action.

(2) The Attorney General and the county attorney of the county in which the public body ordinarily meets shall enforce the Open Meetings Act.

(3) Any citizen of this state may commence a suit in the district court of the county in which the public body ordinarily meets or in which the plaintiff resides for the purpose of requiring compliance with or preventing violations of the Open Meetings Act, for the purpose of declaring an action of a public body void, or for the purpose of determining the applicability of the act to discussions or decisions of the public body. It shall not be a defense that the citizen attended the meeting and failed to object at such time. The court may order payment of reasonable attorney's fees and court costs to a successful plaintiff in a suit brought under this section.

(4) Any member of a public body who knowingly violates or conspires to violate or who attends or remains at a meeting knowing that the public body is in violation of any provision of the Open Meetings Act shall be guilty of a Class IV misdemeanor for a first offense and a Class III misdemeanor for a second or subsequent offense.

Source: Laws 1975, LB 325, § 9; Laws 1977, LB 39, § 318; Laws 1983, LB 43, § 5; Laws 1992, LB 1019, § 126; Laws 1994, LB 621, § 2; Laws 1996, LB 900, § 1074; Laws 2004, LB 821, § 40; Laws 2006, LB 898, § 4.

Annotations

- The Legislature has granted standing to a broad scope of its citizens for the very limited purpose of challenging meetings allegedly in violation of the Open Meetings Act, so that they may help police the public policy embodied by the act. *Schauer v. Grooms*, 280 Neb. 426, 786 N.W.2d 909 (2010).

- Any citizen of the state may commence an action to declare a public body's action void. *City of Elkhorn v. City of Omaha*, 272 Neb. 867, 725 N.W.2d 792 (2007).
- The reading of ordinances constitutes a formal action under subsection (1) of this section. *City of Elkhorn v. City of Omaha*, 272 Neb. 867, 725 N.W.2d 792 (2007).
- If a person present at a meeting observes a public meetings law violation in the form of an improper closed session and fails to object, that person waives his or her right to object at a later date. *Wasikowski v. Nebraska Quality Jobs Bd.*, 264 Neb. 403, 648 N.W.2d 756 (2002).
- Under the Public Meetings Act, a county lacks capacity to maintain an action to declare its official conduct "void" for noncompliance with the act. *County of York v. Johnson*, 230 Neb. 403, 432 N.W.2d 215 (1988).
- When a petitioner under this section is successful in the district court, that court may allow attorney fees. *Tracy Corp. II v. Nebraska Pub. Serv. Comm.*, 218 Neb. 900, 360 N.W.2d 485 (1984).
- Informal discussions between the Tax Commissioner and the State Board of Equalization in which instructions were clarified, with such clarification leading to the amendment of hearing notices, did not constitute a public meeting subject to the provisions of this section. *Box Butte County v. State Board of Equalization and Assessment*, 206 Neb. 696, 295 N.W.2d 670 (1980).
- The right to collaterally attack an order made in contravention of the Public Meeting Act must occur within a period of one year as is specifically provided by this section. *Witt v. School District No. 70*, 202 Neb. 63, 273 N.W.2d 669 (1979).
- Statutory change, requiring "publicized notice" for board of education employment hearings, occurring between dates meeting scheduled and conducted, held not to void proceedings. *Alexander v. School Dist. No. 17*, 197 Neb. 251, 248 N.W.2d 335 (1976).
- Voiding an entire meeting is a proper remedy for violations of the Open Meetings Act. Once a meeting has been declared void pursuant to Nebraska's public meetings law, board members are prohibited from considering any information obtained at the illegal meeting. *Wolf v. Grubbs*, 17 Neb. App. 292, 759 N.W.2d 499 (2009).
- Actions by the board of directors were merely voidable under this section, and not void. Pursuant to subsection (3) of this section, the plaintiffs were awarded partial attorney fees because they were successful in having the court declare that the board of directors was in substantial violation of the statute, even though the plaintiffs did not get the relief requested of having the board's actions declared void. *Hansmeyer v. Nebraska Pub. Power Dist.*, 6 Neb. App. 889, 578 N.W.2d 476 (1998).

--

Source: http://nebraskalegislature.gov/laws/display_html.php?begin_section=84-1407&end_section=84-1414

Date: July 2022

2. PRAYER

3. NATIONAL ANTHEM AND PLEDGE OF ALLEGIANCE

4. CONSENT AGENDA - The following items are considered to be routine by the city council and will be enacted by one motion. There will be no separate discussion of these items unless a city council member or citizen so requests, in which event the item will be removed from consent status and considered in its normal sequence on the agenda.

4.A. Minutes of August 21, 2023, City Council meeting.

PROCEEDINGS OF CITY COUNCIL
August 21, 2023

A regular meeting of the mayor and city council of the City of Columbus, Nebraska, was convened in open and public session on August 21, 2023, at 6 p.m. in the Columbus Community Building, Community Room, 2500 14 Street, Columbus, Nebraska.

Notice of this meeting was given in advance thereof by publication in the Columbus Telegram on July 26, 2023, with a copy of the proof of publication being on file in the office of the city clerk. Notice of this meeting was given simultaneously to the mayor and members of the city council, with a copy of the acknowledgment of receipt of notice being on file in the office of the city clerk. Availability of the agenda was communicated in the advance notice and in the notice to the mayor and city council of this meeting. All proceedings hereafter shown were taken while the convened meeting was open to the public.

1. **STATEMENT OF COMPLIANCE WITH OPEN MEETINGS ACT AND ROLL CALL:** Mayor Bulkley announced that a copy of the Open Meetings Act is posted in the meeting room. Present were Mayor James Bulkley and Council Members Beth Augustine-Schulte, Charlie Bahr, Hope Freshour, Troy Hiemer, Rich Jablonski, Prent Roth, and Ron Schilling. Council Member Kat Lopez was absent and excused. City staff members included City Attorney Neal Valorz, City Administrator Tara Vasicek, City Clerk Janelle Kline, City Engineer Rick Bogus, Police Chief Chuck Sherer, Public Works Director Chuck Sliva, Planning & Economic Development Director Jean Van Iperen, Airport Manager Ross Niedbalski, and Communications Manager Matt Lindberg.
2. **PRAYER:** Augustine-Schulte led in prayer.
3. **NATIONAL ANTHEM AND PLEDGE OF ALLEGIANCE:** The National Anthem was sung and the Pledge of Allegiance was recited.
4. **CONSENT AGENDA:** Vasicek stated that the following items are considered routine by the city council and will be enacted by one motion. She pointed out there will be no separate discussion of these items unless a city council member or citizen so requests, in which event the item will be removed from consent status and considered in its normal sequence on the agenda. Roth requested that Item 4.F. Resolution No. R23-109 authorizing application to Nebraska Game and Parks Commission for Land and Water Conservation Fund grant in the amount of \$175,000 for a splash pad in Centennial Park be removed from consent status and considered in its normal sequence under Item 14, Resolutions. The items on the consent agenda, with the exception of Item 4.F., were approved with a motion by Augustine-Schulte and a second by Bahr. Augustine-Schulte, Bahr, Freshour, Hiemer, Jablonski, Lopez, Roth, and Schilling voted "Aye" and none voted "Nay". Lopez was absent.

- 4.A. Minutes of August 7, 2023, City Council meeting.**
- 4.B. Minutes of August 7, 2023, Community Development Agency meeting.**
- 4.C. Quote from Obrist & Company, Inc. in the amount of \$39,955 for storm sewer cleaning.**
- 4.D. Resolution No. R23-88 approving a permanent drainage easement agreement with Aaron J. and Jayme M. Puntney.** Resolution No. R23-88 is entitled: A RESOLUTION OF THE MAYOR AND COUNCIL OF THE CITY OF COLUMBUS, NEBRASKA, APPROVING THE DRAINAGE EASEMENT AGREEMENT WITH AARON J. AND JAYME M. PUNTNEY A COPY OF WHICH IS ATTACHED HERETO AND INCORPORATED HEREIN; TO AUTHORIZE THE MAYOR TO EXECUTE THE SAME ON BEHALF OF THE CITY OF COLUMBUS; AND TO REPEAL ALL RESOLUTIONS OR PORTIONS THEREOF IN CONFLICT HEREWITH.
- 4.E. Resolution No. R23-108 approving agreement with Mark S. Howerter, M.D. for reappointment as medical director.** Resolution No. R23-108 is entitled: A RESOLUTION OF THE MAYOR AND COUNCIL OF THE CITY OF COLUMBUS, NEBRASKA, APPROVING AN AGREEMENT WITH MARK S. HOWERTER, M.D. FOR REAPPOINTMENT AS MEDICAL DIRECTOR FOR THE COLUMBUS FIRE DEPARTMENT AND ANY OTHER EMT EMPLOYED BY THE CITY OF COLUMBUS WHOSE TRAINING RECORDS ARE MAINTAINED BY THE COLUMBUS FIRE DEPARTMENT, A COPY OF WHICH IS ATTACHED HERETO AND INCORPORATED HEREIN; TO AUTHORIZE THE MAYOR TO EXECUTE THE SAME; AND TO REPEAL ALL RESOLUTIONS OR PORTIONS THEREOF IN CONFLICT HEREWITH.
- 4.G. Resolution No. R23-110 authorizing payment of various improvement projects.** Resolution No. R23-110 is entitled: A RESOLUTION OF THE MAYOR AND COUNCIL OF THE CITY OF COLUMBUS, NEBRASKA, TO AUTHORIZE AND DIRECT THAT A CHECK BE ISSUED AND MADE PAYABLE TO THE RESPECTIVE CONTRACTOR(S) FOR LABOR, EQUIPMENT, AND MATERIALS FURNISHED FOR IMPROVEMENTS IN THE FOLLOWING DESIGNATED DISTRICTS AND PROJECTS WITHIN THE CITY OF COLUMBUS, ALL AS SET FORTH ON THE ATTACHED CERTIFICATES OF PROGRESS PREPARED BY THE RESPECTIVE SPECIAL ENGINEER TO WIT: BOYD JONES CONSTRUCTION CO., COMMUNITY BUILDING, \$265,296.43; GEHRING CONSTRUCTION AND READY MIX CO. INC., SID NO. 184 23RD STREET FROM EAST OF 48TH AVENUE TO 54TH AVENUE, \$199,524.82; PLATTE VALLEY PRECAST, AIRPORT HANGAR, \$1,350.00; PLATTE VALLEY PRECAST, AIRPORT HANGAR, \$4,945.55.
- 4.H. Finance Department reports.**
- 4.I. Payroll and bills on file.** B=Bond Payments; CP=Capital Projects; E=Expenses; G=Grants; I=Insurance; L=License; M=Membership;

PROCEEDINGS OF CITY COUNCIL

August 21, 2023

Page 3

P=Payment; R=Refund; S=Service & Supplies; T=Training; 9/1/23 Payroll \$760,493.97; 4Imprint 1,189.80 S; 911 Custom 352.00 S; A to Z Databases 2,684.00 S; A to Z Messaging 125.00 S; Ace Hrdwr 780.34 S; Advance Auto 970.16 S; Ag Spray Eq 20.94 S; A Albers 60.00 S; AlphaMedia 750.00 S; American Timber & Steel 1,065.95 S; Aqua-Chem 1,111.80 S; Aqua-Pure 13,477.41 S; Arnold Motor 595.69 S; AT&T 80.08 S; B2 Environ 46,182.50 CP; Baird Holm 693.00 S; Behlen Tow 1,300.00 S; BGNE 201.06 S; Big Red Prntg 10.00 S; Black Hills Energy 2,430.17 S; Blackstone Pub 167.95 S; T Blevins 200.00 S; D Borchers 330.00 S; Boyd Jones 265,296.43 CP; Brewster's Back Yard BBQ 750.00 S; Bullseye Fire Sprinklers 700.00 S; BVH 4,482.56 CP; Capital Busi Sys 27.62 S; Casey's Mail Serv 4,836.43 S; Cntr Pnt LP 94.08 S; CCC 75.00 T; Cntrl Valley 1,295.45 S; Century Link 930.00 S; Chrome N' Steel 142.42 S; City of Col 205.55 S; R Closson 390.00 S; Club Prophet 500.00 S; CNC Repair 2,261.89 S; Col Area Chamber 2,140.00 S,T; CCH 1,005.50 S; CCS 453.83 S; Col Family Res 10,609.99 S; Col Rescue Miss 7.62 R; Col Sm Animal Hosp 120.54 S; Col Telegram 615.24 S; Core & Main 1,372.86 S; Cornhusker Pwr 920.42 S; Culligan 213.50 S; Danko 179.34 S; DAS St Acc 132.00 S; Dell Mrktg 2,016.46 S; Demco 200.27 S; Discover Sprts Booster Clb 250.00 S; D Douglas 43,699.90 S; Dymaxion Rsrch 1,992.00 S; Eakes 3,453.44 S; Edison Ltg Sup 629.70 S; Electric Pump 1,719.24 S; Electrical Eng 22.44 S; Electronic Eng 168.63 S; Enterprise Ele 18.50 S; ESRI 8,300.00 S; Fifth Season 167.18 S; First Impressions 2,075.00 S; Frst Ntnal Bnk 10,440.30 S; Frontier 2,585.35 S; Gale 78.72 S; Galls 520.29 S; E Galvan 322.94 R; Gehring Const 257,785.04 S,CP; Gerhold 521.93 S; Golfnow 185.66 S; Grainger 153.30 S; J Gutierrez 330.00 S; Hadley-Braithwait 591.70 S; Hawkins 12,484.47 S; HDR 23,384.70 CP; Hrtld Gas 3,231.97 S; Hrtld Office Clnrs 500.00 S; HOA 200.62 S; B Hoeft 210.00 T; M Howerter MD 1,232.00 S; HR Direct 98.74 E; Hy-Vee 599.94 S; Identi-Kit Sol 204.00 S; Ingram Libry 891.77 S; Interst Battery Sys 147.95 S; Intoximeters 176.50 S; Jackson Serv 1,996.79 S; Kelly Sup 1,097.63 S; E Kluever 500.00 T; J Krepel 22.18 S; A Laborde 5,600.00 S; Lkvw Sm Eng 331.95 S; Language Line 374.15 S; League of NE Munic 57,018.00 T,M; Library Store 216.70 S; Lincoln Journal Star 771.00 S; Lingo 61.68 S; C Lloyd 31.00 R; Loup 113,696.15 S; M&L 6,197.85 S; Matheson-Linweld 30.06 S; McMaster-Carr 176.33 S; MD Sol 258.55 S; Medline Ind 1,412.75 S; Menards 646.05 S; Microfilm Imaging Sys 5,263.00 S; Mid-St 70.00 CP; MidW Lab 173.60 S; Mike's Tow 900.00 S; Motion Ind 2,820.22 S; C Mroczek 500.00 S; Mueller Sprinklers 113.97 S; Munic Pipe Tool 2,336.58 S; NE Golf&Turf 214.15 S; NE Harvestore Sys 87.13 S; NE Law Enforce 19.55 E; Newman Signs 483.04 S; NE NE Solid 134,304.65 S; NW Elec 369.53 S; Occup Hlth 297.00 S; Olson's Pest 527.50 S; Omaha World Herald 774.80 S; One Call 365.08 S; One Src 918.00 S; O'Reilly 1,438.33 S; Otte Elec 687.76 S; Paper Tiger 75.00 S; Pete Lien & Sons 6,853.56 S; Petty Cash 183.65 S; Platte Cnty 6,068.00 S; Platte Valley Precast 6,295.55 CP; Police Officers' Assoc 12.00 T; Pomp's Tire 549.03 S; Port-A-Johns 450.00 S; Prestox 62.24 S; Quadient Fin 1,000.00 S; Reardon 102.97 S; Rembolt Ludtke 400.00 S; Riverside Port 380.00 S; Rutt's 67.14 S; Sapp Bros 33,488.72 S; Settje Plumbing 187.31 S; Sherwin-Williams 243.39 S; Shelvin Sup 1,424.98

S; Sipple, Hansen, Emerson, Schumacher, Klutman, & Valorz 4,983.40 S; Sirius 254.24 S; Snap-On 105.00 S; Standard & Assoc 402.00 E; Stanley Petro 5,170.53 S; St of NE 50.00 R; K Strong 60.00 R; Stryker Sales 177.80 S; Super Svr 72.79 S; Sysco 25,986.95 S; T-Bone 70.48 S; Telecomm Sys 1,970.67 S; The Home Depot 252.20; Tire Outlet 660.00 S; TK Elevator 228.75 S; Too Fast Sup 98.97 S; Tractor Sup 39.48 S; Tumbleweed Prs 1,677.90; Ty's Outdoor 178.35 S; U&I 35.00 S; UPS 43.69 S; USA Blue Bk 7,557.03 S; Utilities Sect 4,002.00 M; Van Diest Heating & Air 292.11 S; C Van Dyke 146.50 S; Vendnovation 1,200.00 S; Verizon Wireless 4,486.59 S; VonRentzell 38,436.00 S; Waste Conn 350.01 S; Webstaurantstore 14,159.64 CP; W Pnt Implem 246.80 S; Wilson & Co 2,776.02 CP; Witmer Pub Sfty 588.19 S. TOTAL \$2,034,326.08.

5. **APPROVAL OF MINUTES:** Included in Consent Agenda

6. **SPECIAL PRESENTATIONS:** None

7. **PUBLIC HEARINGS:**

7.A. **Public hearing - Application of James Ferguson for final plat of Deerfield Park Townhouse 2nd Subdivision (38th Street east of 26th Avenue). Applicant has requested this public hearing be continued to the September meeting. (Continued from the July 17, 2023, meeting.)** The public hearing was continued to September 18, 2023, at 6 p.m. with a motion by Roth and a second by Schilling. Augustine-Schulte, Bahr, Freshour, Hiemer, Roth, and Schilling voted "Aye" and Jablonski voted "Nay". Lopez was absent.

8. **PETITIONS AND COMMUNICATIONS:** None

9. **REPORTS OF CITY OFFICES:** Included in Consent Agenda

10. **REPORTS OF COUNCIL COMMITTEES:**

10.A. **PUBLIC PROPERTY, SAFETY, AND WORKS COMMITTEE – August 14, 2023.**

10.A.1. **Request of St. Isidore Church to vacate portion of 20th Street and cul-de-sac located west of Gruenther Drive.** The Public Property, Safety, and Works Committee recommended approval to vacate a portion of 20th Street and the cul-de-sac located west of Gruenther Drive. The report was adopted with a motion by Bahr and a second by Schilling. Augustine-Schulte, Bahr, Freshour, Hiemer, Jablonski, Roth, and Schilling voted "Aye" and none voted "Nay". Lopez was absent.

10.A.2. **Request of Harold Henry to amend Unified Land Development Ordinance relating to number of garage sales allowed at one location per year.** Vasicek explained that Mr. Henry requested that garage sales be allowed once per month or no more than four per year as opposed to the current restriction of once every two months with no more than four per year. The Public Property,

Safety, and Works Committee recommended that the current regulations for garage sales remain in place. The report was adopted with a motion by Bahr and a second by Schilling. Augustine-Schulte, Bahr, Freshour, Hiemer, Jablonski, Roth, and Schilling voted "Aye" and none voted "Nay". Lopez was absent.

10.A.3. 2024 Pavement Management Program and Priority List. The Public Property, Safety, and Works Committee recommended approval of the 2024 Pavement Management Program and Priority List. The report was adopted with a motion by Augustine-Schulte and a second by Bahr. Augustine-Schulte, Bahr, Freshour, Hiemer, Jablonski, Roth, and Schilling voted "Aye" and none voted "Nay". Lopez was absent.

10.A.4. 2024 One and Six Year Road Plan. The Public Property, Safety, and Works Committee recommended approval of the 2024 One and Six Year Road Plan and setting the public hearing for September 5, 2023, at 6 p.m. The report was adopted with a motion by Bahr and a second by Schilling. Augustine-Schulte, Bahr, Freshour, Hiemer, Jablonski, Roth, and Schilling voted "Aye" and none voted "Nay". Lopez was absent.

11. REPORTS OF SPECIAL COMMITTEES: None

12. REPORTS ON LEGISLATION: None

13. NEW BUSINESS:

13.A. Appointment of Thomas Rathje as firefighter/EMT/paramedic/hazmat technician. Augustine-Schulte read a brief resume and the mayor's appointment of Thomas Rathje as firefighter/EMT/paramedic/hazmat technician was ratified with a motion by Roth and a second by Bahr. Augustine-Schulte, Bahr, Freshour, Hiemer, Jablonski, Roth, and Schilling voted "Aye" and none voted "Nay". Lopez was absent. Rathje stated that he is honored and humbled by the appointment and said he looks forward to serving in Columbus.

13.B. Quotes from Heiman Fire Equipment and Danko Emergency Equipment in the total amount of \$15,579.98 for mounting equipment for two fire engines. The quotes from Heiman Fire Equipment and Danko Emergency Equipment for mounting equipment were accepted with a motion by Augustine-Schulte and a second by Bahr. Augustine-Schulte, Bahr, Freshour, Hiemer, Jablonski, Roth, and Schilling voted "Aye" and none voted "Nay". Lopez was absent.

13.C. Quote from WebstaurantStore in the amount of \$14,159.64 for 12 trash receptacles at Frankfort Square. Van Iperen described the 45-gallon, 140 pound receptacles and said they are heavy duty for durability, have a front door enclosure for easier emptying, and have a hood over the top for protection from the weather. The quote from WebstaurantStore for trash receptacles was accepted with a motion by Augustine-Schulte and a second by Roth.

Augustine-Schulte, Bahr, Freshour, Hiemer, Jablonski, Roth, and Schilling voted "Aye" and none voted "Nay". Lopez was absent.

13.D. Quote from Sirius in the amount of \$12,035.16 for virtual host additional memory. The quote from Sirius for virtual host additional memory was accepted with a motion by Roth and a second by Augustine-Schulte. Augustine-Schulte, Bahr, Freshour, Hiemer, Jablonski, Roth, and Schilling voted "Aye" and none voted "Nay". Lopez was absent.

13.E. Plans, specifications, HDR Engineering's estimate of cost in the amount of \$391,100, and authorization to advertise for bids for Lost Creek Parkway sewer extension from 63rd Avenue to U.S. Highway 81. (Plans and specifications on file in the engineering department.) The plans, specifications, estimate of cost, and authorization to advertise for bids for Lost Creek Parkway sewer extension from 63rd Avenue to U.S. Highway 81 were approved with a motion by Bahr and a second by Hiemer. Augustine-Schulte, Bahr, Freshour, Hiemer, Jablonski, Roth, and Schilling voted "Aye" and none voted "Nay". Lopez was absent.

13.F. Comments from mayor and city council members. There were no comments from the mayor or council members.

14. RESOLUTIONS:

14.A. Resolution No. R23-111 approving interlocal agreement with Platte County for asphalt improvements on 33rd Avenue from 47th Street to 53rd Street. Resolution No. R23-111 entitled: A RESOLUTION OF THE MAYOR AND COUNCIL OF THE CITY OF COLUMBUS, NEBRASKA, APPROVING AN INTERLOCAL COOPERATION AGREEMENT WITH PLATTE COUNTY FOR ASPHALT IMPROVEMENTS ON 33RD AVENUE FROM 47TH STREET TO 53RD STREET was adopted with a motion by Bahr and a second by Augustine-Schulte. Augustine-Schulte, Bahr, Freshour, Hiemer, Jablonski, Roth, and Schilling voted "Aye" and none voted "Nay". Lopez was absent.

14.B. Resolution No. R23-112 approving agreement with JEO Consulting Group, Inc. in an amount not to exceed \$65,000 for 2023 Storm Water Treatment Facility Bank Study. Bogus explained the purpose for this study would be to assess options for city-owned or public-owned properties to potentially be used as stormwater treatment facilities. Developers would have the option to buy into these facilities for stormwater treatment of new developments. Resolution No. R23-112 entitled: A RESOLUTION OF THE MAYOR AND COUNCIL OF THE CITY OF COLUMBUS, NEBRASKA, APPROVING AN AGREEMENT BETWEEN OWNER AND ENGINEER WITH JEO CONSULTING GROUP, INC., IN AN AMOUNT NOT TO EXCEED \$65,000 FOR STORM WATER TREATMENT FACILITY BANK STUDY 2023, A COPY OF WHICH IS ATTACHED HERETO AND INCORPORATED HEREIN; TO AUTHORIZE THE MAYOR TO EXECUTE THE SAME ON

BEHALF OF THE CITY; AND TO REPEAL ALL RESOLUTIONS OR PORTIONS THEREOF IN CONFLICT HEREWITH was adopted with a motion by Hiemer and a second by Augustine-Schulte. Augustine-Schulte, Bahr, Freshour, Hiemer, Jablonski, Roth, and Schilling voted "Aye" and none voted "Nay". Lopez was absent.

- 14.C. Resolution No. R23-113 amending Columbus Municipal Airport Rules and Regulations.** Niedbalski explained that the proposed changes to the rules and regulations regarding hours of operation, holidays, and insurance requirements were made to reflect the terms of the recently approved Fixed Base Operator agreement. He also noted that following research of comparable cities, it was determined that the elimination of ramp fees would be in the best interest of the city. He stated that he emailed the proposed rules and regulations to the Board of Airport Commissioners after their July meeting was cancelled due to lack of a quorum and said only three of the five members responded with all three being supportive of the changes. Resolution No. R23-113 entitled: A RESOLUTION OF THE MAYOR AND COUNCIL OF THE CITY OF COLUMBUS, NEBRASKA, ADOPTING UPDATED RULES AND REGULATIONS FOR THE COLUMBUS MUNICIPAL AIRPORT was adopted with a motion by Freshour and a second by Augustine-Schulte. Augustine-Schulte, Bahr, Freshour, Hiemer, Jablonski, Roth, and Schilling voted "Aye" and none voted "Nay". Lopez was absent.
- 14.D. Resolution No. R23-114 approving Memorandum of Agreement with United States Department of Agriculture, Rural Development, and Nebraska State Historic Preservation Office for implementing plans to construct a parking lot at 1471 25 Avenue.** Resolution No. R23-114 entitled: A RESOLUTION OF THE MAYOR AND COUNCIL OF THE CITY OF COLUMBUS, NEBRASKA, APPROVING THE MEMORANDUM OF AGREEMENT WITH THE UNITED STATES DEPARTMENT OF AGRICULTURE, RURAL DEVELOPMENT AND THE NEBRASKA STATE HISTORIC PRESERVATION OFFICE FOR IMPLEMENTATION OF PLANS WITH STIPULATIONS FOR CONSTRUCTION OF A PARKING LOT AT 1471 25 AVENUE; TO AUTHORIZE THE MAYOR TO EXECUTE THE SAME ON BEHALF OF THE CITY OF COLUMBUS; AND TO REPEAL ALL RESOLUTIONS OR PORTIONS THEREOF IN CONFLICT HEREWITH was adopted with a motion by Roth and a second by Jablonski. Augustine-Schulte, Bahr, Freshour, Hiemer, Jablonski, Roth, and Schilling voted "Aye" and none voted "Nay". Lopez was absent.
- 14.E. Resolution No. R23-115 approving Columbus Destination Business Guidelines to increase awareness and access to retail trade funds available through the Economic Development Plan.** Vasicek explained that the Columbus Economic Development Plan allows funds to be used for retail and the guidelines will provide a tool to aid in the promotion of retail development. Resolution No. R23-115 entitled: A RESOLUTION OF THE MAYOR AND COUNCIL OF THE CITY OF COLUMBUS, NEBRASKA,

APPROVING THE COLUMBUS DESTINATION BUSINESS GUIDELINES TO INCREASE AWARENESS AND ACCESS TO RETAIL TRADE FUNDS AVAILABLE THROUGH THE CITY OF COLUMBUS' ECONOMIC DEVELOPMENT PLAN, A COPY OF WHICH IS ATTACHED HERETO AND INCORPORATED HEREIN; AND TO REPEAL ALL RESOLUTIONS OR PORTIONS THEREOF IN CONFLICT HEREWITH was adopted with a motion by Jablonski and a second by Schilling. Augustine-Schulte, Bahr, Freshour, Hiemer, Jablonski, Roth, and Schilling voted "Aye" and none voted "Nay". Lopez was absent.

- 4.F. Resolution No. R23-109 authorizing application to Nebraska Game and Parks Commission for Land and Water Conservation Fund grant in the amount of \$175,000 for a splash pad in Centennial Park.** Roth expressed opposition to this resolution as he feels a master plan for Centennial Park should be in place prior to making any improvements. Eckhardt noted the grant deadlines. Bulkley suggested the council proceed with the grant application while options for a plan for the park be researched. Resolution No. R23-109 entitled: A RESOLUTION OF THE MAYOR AND COUNCIL OF THE CITY OF COLUMBUS, NEBRASKA, AUTHORIZING AN APPLICATION TO THE NEBRASKA GAME AND PARKS COMMISSION FOR THE LAND AND WATER CONSERVATION FUND GRANT IN THE AMOUNT OF \$175,000 FOR A SPLASH PAD IN CENTENNIAL PARK; TO AUTHORIZE THE MAYOR TO EXECUTE THE SAME ON BEHALF OF THE CITY; AND TO REPEAL ALL RESOLUTIONS OR PORTIONS THEREOF IN CONFLICT HEREWITH was adopted with a motion by Augustine-Schulte and a second by Bahr. Augustine-Schulte, Bahr, Freshour, Hiemer, Jablonski, Roth, and Schilling voted "Aye" and none voted "Nay". Lopez was absent.

15. ORDINANCES ON FIRST READING:

- 15.A. Ordinance No. 23-11 vacating portion of 20th Street and cul-de-sac located west of Gruenther Drive.** The rules were suspended and Ordinance No. 23-11 entitled: AN ORDINANCE OF THE MAYOR AND COUNCIL OF THE CITY OF COLUMBUS, NEBRASKA, VACATING THAT PORTION OF 20TH STREET AS PREVIOUSLY PLATTED WITHIN WEST PARK FIRST ADDITION AND SAINT ISIDORE CHURCH ADDITION, ALL TO THE CITY OF COLUMBUS, PLATTE COUNTY, NEBRASKA, BEING DESCRIBED AS FOLLOWS; BEGINNING AT THE SOUTHWEST CORNER OF LOT 3, BLOCK E, OF SAID WEST PARK FIRST ADDITION; THENCE EASTERLY ON THE SOUTH LINE OF SAID LOT 3, THIS ALSO BEING THE NORTH LINE OF SAID 20TH STREET, FOR 65.0 FEET, MORE OR LESS, TO THE SOUTHEAST CORNER OF SAID LOT 3; THENCE SOUTHERLY PERPENDICULAR TO THE SOUTH LINE OF SAID LOT 3 FOR 50.0 FEET, MORE OR LESS, TO A POINT ON THE NORTH LINE OF BLOCK C, OF SAID WEST PARK FIRST ADDITION, THIS ALSO BEING THE SOUTH LINE OF SAID 20TH STREET; THENCE WESTERLY ON THE NORTH LINE OF SAID BLOCK C AND THE SOUTH LINE OF SAID 20TH STREET FOR 55.1 FEET, MORE OR

LESS, TO A POINT OF CURVATURE; THENCE ON A 43.0 FOOT RADIUS CURVE TO THE RIGHT ON SAID 20TH STREET RIGHT-OF-WAY LINE FOR 215.46 FEET (ARC DISTANCE), MORE OR LESS, TO THE SOUTHWEST CORNER OF SAID LOT 3 AND THE POINT OF BEGINNING, EFFECTIVE AUGUST 21, 2023; PROVIDING FOR THE RETENTION OF UTILITY EASEMENTS WHICH CONSIST OF AN EXISTING WATER MAIN, AN EXISTING SANITARY SEWER MAIN AND AN EXISTING STORM SEWER MAIN AND INCLUDING THE ACCEPTANCE OF STORMWATER RUNOFF FROM PUBLIC RIGHT OF WAY; PROVIDING FOR THE EFFECTIVE DATE HEREOF; PROVIDING FOR THE REPEAL OF ALL ORDINANCES AND RESOLUTIONS OR PARTS THEREOF IN CONFLICT HEREWITH; AND TO PROVIDE THAT PUBLICATION SHALL BE IN PAMPHLET FORM AS AUTHORIZED BY §16-405 OF NEBRASKA REVISED STATUTES was read by number only with a motion by Hiemer and a second by Jablonski. Augustine-Schulte, Bahr, Freshour, Hiemer, Jablonski, Roth, and Schilling voted "Aye" and none voted "Nay". Lopez was absent. Ordinance No. 23-11 was adopted with a motion by Hiemer and a second by Jablonski. Augustine-Schulte, Bahr, Freshour, Hiemer, Jablonski, Roth, and Schilling voted "Aye" and none voted "Nay". Lopez was absent.

16. ORDINANCES ON SECOND READING: None

17. ORDINANCES ON THIRD READING:

17.A. Ordinance No. 23-09 adopting Columbus Land Development Ordinance. On its third reading, Ordinance No. 23-09 entitled: AN ORDINANCE OF THE MAYOR AND COUNCIL OF THE CITY OF COLUMBUS, NEBRASKA, REPEALING THE EXISTING UNIFIED LAND DEVELOPMENT ORDINANCE OF THE CITY OF COLUMBUS, NEBRASKA, ADOPTED BY ORDINANCE NO. 20-32 ON JANUARY 18, 2021; ADOPTING THE COLUMBUS LAND DEVELOPMENT ORDINANCE AS SET FORTH HEREIN; INCORPORATING THE COLUMBUS LAND DEVELOPMENT ORDINANCE INTO THE COLUMBUS CITY CODE AS TITLE XV, CHAPTER 151, ZONING CHAPTER AND CHAPTER 152, SUBDIVISION CHAPTER; PROVIDING FOR THE PUBLICATION OF THIS ORDINANCE IN PAMPHLET FORM; PROVIDING FOR THE EFFECTIVE DATE HEREOF AND PROVIDING FOR THE REPEAL OF ALL ORDINANCES IN CONFLICT HEREWITH was adopted with a motion by Bahr and a second by Schilling. Augustine-Schulte, Bahr, Freshour, Hiemer, Jablonski, Roth, and Schilling voted "Aye" and none voted "Nay". Lopez was absent.

18. CONSIDERATION OF PAYROLL AND BILLS ON FILE: Included in Consent Agenda.

19. UNFINISHED BUSINESS: None

20. ADJOURNMENT: The meeting adjourned at 6:46 p.m.

PROCEEDINGS OF CITY COUNCIL

August 21, 2023

Page 10

Presented and approved this 5th day of September, 2023.

OFFICE OF THE CITY CLERK

:Janelle Kline

4.B. Minutes of August 28, 2023, Civil Service Commission meeting.

CIVIL SERVICE COMMISSION MINUTES

August 28, 2023

A meeting of the Columbus Civil Service Commission was convened in open and public session on Monday, August 28, 2023 at 4:45 p.m. in the Conference Room at the Police Station.

Notice of this meeting was given in advance thereof by public posting in City Hall, Platte County Courthouse, and Columbus Public Library on August 15, 2023. Availability of the agenda was communicated in the advance notice and in the notice to the Columbus Civil Service Commission of this meeting. All proceedings hereafter shown were taken while the convened meeting was open to the public.

STATEMENT OF COMPLIANCE WITH OPEN MEETINGS ACT AND ROLL CALL:

The following statement: "In compliance with the Open Meetings Act, Legislative Bill 898, Second Session Ninety-Ninth Legislature of Nebraska, a current copy of the Act is available in this meeting room".

Present were members, Logan Bronson, Chris Steinke, and Troy Loeffelholz, Jessica Caban and Russ Strehle. The minutes from the July 17, 2023 meeting were approved with a motion by Steinke and a second by Caban with all members voting "Aye".

The purpose of the meeting was to interview one applicant for the position of Police Officer and agree if the candidate would be certified to the appointing authority as qualified for the position of Police Officer for one year.

Following discussion, it was moved by Strehle and seconded by Steinke to certify to the Mayor and City Council, the applicant Brittany Warren. The motion passed unanimously.

There being no further items of business for the agenda, the meeting was adjourned.

Respectfully submitted,

Tammy Orender
Civil Service Commission Secretary

4.C. Resolution No. R23-116 authorizing payments of various improvement projects.

RESOLUTION NO. R23-116

A RESOLUTION OF THE MAYOR AND COUNCIL OF THE CITY OF COLUMBUS, NEBRASKA, TO AUTHORIZE AND DIRECT THAT A CHECK BE ISSUED AND MADE PAYABLE TO THE RESPECTIVE CONTRACTOR(S) FOR LABOR, EQUIPMENT, AND MATERIALS FURNISHED FOR IMPROVEMENTS IN THE FOLLOWING DESIGNATED DISTRICTS AND PROJECTS WITHIN THE CITY OF COLUMBUS, ALL AS SET FORTH ON THE ATTACHED CERTIFICATES OF PROGRESS PREPARED BY THE RESPECTIVE SPECIAL ENGINEER TO WIT: B-D CONSTRUCTION, INC., SENIOR CENTER ENTRY RENO, \$24,4004.40; GEHRING CONSTRUCTION AND READY MIX COMPANY INC., SID NO. 189 48TH AVENUE FROM 23RD STREET TO SOUTH OF BRADSHAW PARK ENTRANCE & CONCRETE PAVING IMPROVEMENTS 2023, \$433,477.75; NEMAHA LANDSCAPE CONSTRUCTION, INC. COLUMBUS PAWNEE PARK, \$57,900.00.

WHEREAS, the mayor and council of the City of Columbus, Nebraska, hereby find and determine that pursuant to contract, labor, equipment, and materials have been furnished for improvements in the following designated districts and projects within said City, to wit:

B-D Construction, Inc.	Senior Center Entry Reno	\$ 24,404.40
Gehring Const & Ready Mix Co.	SID No. 189 48 th Ave. from 23 rd St. To S. of Bradshaw Pk Entrance & Concrete Paving Improve 2023	\$ 433,477.75
Nemaha Landscape Const., Inc.	Columbus Pawnee Park	\$ 57,900.00

that the respective special engineer has prepared and filed with the city clerk a certificate of progress respecting said improvements, copies of which are attached and are hereby incorporated herein by reference and made a part hereof as if fully set forth herein; and that pursuant to said contract, the plans, specifications, and said certificate of progress, there is due the respective contractor on account the amount as set forth in the attached.

NOW, THEREFORE, BE IT RESOLVED BY THE MAYOR AND COUNCIL OF THE CITY OF COLUMBUS, NEBRASKA, that the said improvements in the aforesaid districts and projects and the respective certificate of progress be and are hereby accepted and adopted; that a check be issued and made payable to the respective contractor in the amount and in the manner as set forth in the respective certificate of progress; that each check shall be drawn on the appropriate and respective fund; that each check shall be redeemed and paid upon collection of special assessments and sale of various purpose bonds at the completion of each of said districts and projects.

INTRODUCED BY COUNCIL MEMBER _____

PASSED AND ADOPTED THIS _____ DAY OF _____, 2023.

MAYOR

ATTEST:

CITY CLERK

APPROVED AS TO FORM:

CITY ATTORNEY

**AIA Type Document
Application and Certification for Payment**

TO (OWNER): City of Columbus
2424 14th Street
Columbus, NE 68602-1677

PROJECT: SENIOR CENTER ENTRY RENO

APPLICATION NO: 2
PERIOD TO: 8/30/2023

DISTRIBUTION TO:
 OWNER
 ARCHITECT
 CONTRACTOR

FROM (CONTRACTOR): B-D Construction, Inc.
2154 East 32nd Avenue
Columbus, NE 68601

VIA (ARCHITECT): KPE Architecutre
1016 Leavenworth St.
Omaha, NE 68102

ARCHITECT'S PROJECT NO: 626-001

CONTRACT FOR: Senior Center Entry Renovation

CONTRACT DATE: 3/20/2023

CONTRACTOR'S APPLICATION FOR PAYMENT

Application is made for Payment, as shown below, in connection with the Contract. Continuation Sheet, AIA Type Document is attached.

1. ORIGINAL CONTRACT SUM	\$	155,875.00
2. Net Change by Change Orders	\$	0.00
3. CONTRACT SUM TO DATE (Line 1 + 2)	\$	155,875.00
4. TOTAL COMPLETED AND STORED TO DATE	\$	32,016.00
5. RETAINAGE:		
a. 10.00 % of Completed Work	\$	2,990.10
b. 10.00 % of Stored Material	\$	211.50
Total retainage (Line 5a + 5b)	\$	3,201.60
6. TOTAL EARNED LESS RETAINAGE	\$	28,814.40
(Line 4 less Line 5 Total)		
7. LESS PREVIOUS CERTIFICATES FOR PAYMENT (Line 6 from prior Certificate)	\$	4,410.00
8. CURRENT PAYMENT DUE	\$	24,404.40
9. BALANCE TO FINISH, INCLUDING RETAINAGE (Line 3 less Line 6)	\$	127,060.60

CHANGE ORDER SUMMARY	ADDITIONS	DEDUCTIONS
Total changes approved in previous months by Owner	0.00	0.00
Total approved this Month	0.00	0.00
TOTALS	0.00	0.00
NET CHANGES by Change Order	0.00	

The Undersigned Contractor certifies that to the best of the Contractor's knowledge, information and belief the work covered by this application for Payment has been completed in accordance with the Contract Documents, that all amounts have been paid by the Contractor for Work for which previous Certificates for Payment were issued and payments received from the owner, and that current payment shown herein is now due.

CONTRACTOR: B-D Construction, Inc.
2154 East 32nd Avenue Columbus, NE 68601

By: Bryan L. Kearney Date: 8.30.23
Bryan L. Kearney Treasurer

State of: NE
County of: Platte
Subscribed and Sworn to before me this 30th Day of August 2023

Notary Public: Cheryl L Brewer
My Commission Expires: May 19, 2025

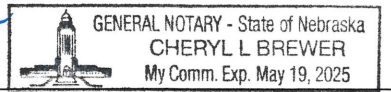

ARCHITECT'S CERTIFICATE FOR PAYMENT

In Accordance with the Contract Documents, based on on-site observations and the data comprising the above application, the Architect certifies to owner that to the best of the Architect's knowledge, information and belief the Work has progressed as indicated, the quality of the work is in accordance with the Contract Documents, and the Contractor is entitled to payment of the AMOUNT CERTIFIED.

AMOUNT CERTIFIED \$ 24,404.40

(Attach explanation if amount certified differs from the amount applied. Initial all figures on this Application and on the Continuation Sheet that are changed to conform to the amount certified.)

ARCHITECT:
By: Richard J. Bogus Date: 8-31-2023

This Certificate is not negotiable. The AMOUNT CERTIFIED is payable only to the Contractor named herein. Issuance, Payment and acceptance of payment are without prejudice to any rights of the Owner or Contractor under this Contract.

**AIA Type Document
Application and Certification for Payment**

TO (OWNER): City of Columbus
2424 14th Street
Columbus, NE 68602-1677

PROJECT: SENIOR CENTER ENTRY RENO

APPLICATION NO: 2
PERIOD TO: 8/30/2023

DISTRIBUTION TO:
_ OWNER
_ ARCHITECT
_ CONTRACTOR

FROM (CONTRACTOR): B-D Construction, Inc.
2154 East 32nd Avenue
Columbus, NE 68601

VIA (ARCHITECT): KPE Architecutre
1016 Leavenworth St.
Omaha, NE 68102

ARCHITECT'S PROJECT NO: 626-001

CONTRACT FOR: Senior Center Entry Renovation

CONTRACT DATE: 3/20/2023

ITEM	DESCRIPTION	SCHEDULE VALUE	PREVIOUS APPLICATIONS	COMPLETED THIS PERIOD	STORED MATERIAL	COMPLETED STORED	%	BALANCE	RETAINAGE
1	General Conditions	17,934.00	0.00	5,978.00	0.00	5,978.00	33.33	11,956.00	597.80
2	Testing	750.00	0.00	375.00	0.00	375.00	50.00	375.00	37.50
3	Select Demolition	4,748.00	0.00	3,100.00	0.00	3,100.00	65.29	1,648.00	310.00
4	Concrete	9,330.00	0.00	6,600.00	0.00	6,600.00	70.74	2,730.00	660.00
5	Rough Carpentry	3,675.00	0.00	1,508.00	0.00	1,508.00	41.03	2,167.00	150.80
6	Thermal Insulation	675.00	0.00	0.00	0.00	0.00	0.00	675.00	0.00
7	Fiber Cement Panels	3,675.00	0.00	0.00	0.00	0.00	0.00	3,675.00	0.00
8	Wood Doors & Hardware	3,995.00	0.00	0.00	2,115.00	2,115.00	52.94	1,880.00	211.50
9	Aluminum Storefront	27,578.00	0.00	0.00	0.00	0.00	0.00	27,578.00	0.00
10	Drywall & Framing	4,578.00	0.00	0.00	0.00	0.00	0.00	4,578.00	0.00
11	Acoustical Ceilings	2,362.00	0.00	0.00	0.00	0.00	0.00	2,362.00	0.00
12	Carpet	4,537.00	0.00	0.00	0.00	0.00	0.00	4,537.00	0.00
13	Paint	2,200.00	0.00	0.00	0.00	0.00	0.00	2,200.00	0.00
14	HVAC	33,600.00	0.00	0.00	0.00	0.00	0.00	33,600.00	0.00
15	Electrical	14,665.00	0.00	0.00	0.00	0.00	0.00	14,665.00	0.00
16	Earthwork / Demo	7,087.00	0.00	7,087.00	0.00	7,087.00	100.00	0.00	708.70
17	Bond	2,570.00	2,570.00	0.00	0.00	2,570.00	100.00	0.00	257.00
18	Overhead & Profit Fees	11,916.00	215.00	2,468.00	0.00	2,683.00	22.52	9,233.00	268.30
REPORT TOTALS		\$155,875.00	\$2,785.00	\$27,116.00	\$2,115.00	\$32,016.00	20.54	\$123,859.00	\$3,201.60



Contractor's Application and Certificate of Payment

200-200-57200-23025 - 164,774.50

200-200-57300-20071 - 268,703.25

		Contractor's Application for Payment No: 10	
		Application Period: (From - to) 7/25/23 to 8/22/23	
To: City of Columbus (Owner)	From (Contractor): Gehring Construction and Ready Mix Co., Inc.	Contractor's Project No.:	
Project Name: SID No. 189 48th Ave. from 23rd St. to S. of Bradshaw Park Entrance & Concrete Paving Improvements 2023			Via (Consulting Engineer / Architect): City of Columbus
Fiscal Year Budget Number: 200-200-57200-23025 & 200-200-57300-20071			

Application For Payment

Field Order and Change Order Summary

Field (FO#) and Change Orders (CO#) Approved:		
Number	Additions	Deductions
FO1	\$ 16,120.00	
FO2	\$ 10,343.00	
TOTALS	\$ 26,463.00	\$ -
NET CHANGE	\$ 26,463.00	

1. ORIGINAL CONTRACT PRICE.....	\$	3,613,722.25
2. Net change by Field Order and Change Orders.....	\$	26,463.00
3. Current Contract Price (Line 1 ± 2).....	\$	3,640,185.25
4. TOTAL COMPLETED AND STORED TO DATE (Column H on Progress Estimate).....	\$	3,402,598.75
5. RETAINAGE: (Capped at 10% at 50% of Line 3) (When line 4 is over 50% of Line 3 do calculation of Line 3 x .5 x .1 to get Retainage)	\$	182,009.26
6. AMOUNT ELIGIBLE TO DATE (Line 4 - Line 5).....	\$	3,220,589.49
7. LESS PREVIOUS PAYMENTS (Line 6 from prior Application).....	\$	2,787,111.74
8. AMOUNT DUE THIS APPLICATION (Line 6 - Line 7).....	\$	433,477.75
9. BALANCE TO FINISH, PLUS RETAINAGE (Line 3- Line 6).....	\$	419,595.76

(To double check Line 9 Take Column 1 + Line 5 should = Line 9 calculations)

Contractor's Certification

The undersigned Contractor certifies that to the best of the Contractor's knowledge, information and belief, the Work covered by this Application for Payment has been completed in accordance with the Contract Documents, that all amounts have been paid by the Contractor for Work for which previous Certificates for Payment were issued and payments received from the Owner, and that current payment shown herein is now due.

Contractor: Gehring Construction & Ready Mix Co., Inc.
 By: Stephen Anderson Date: 8-23-23
 Printed/Typed Name: Stephen Anderson

Payment of: _____
 (Line 8 or other - attach explanation of the other amount)

is recommended by: _____
 (Consulting Engineer/Architect) (Date)

Payment of: \$ _____
 433,477.75
 (Line 8 or other - attach explanation of the other amount)

is approved by: Richard F. Bogue 8-29-2023
 (City Engineer) (Date)

Approved by: _____
 Funding Agency (if applicable) (Date)

APPLICATION AND CERTIFICATE FOR PAYMENT

Containing Contractor's signed Certification is attached

Project Name: SID No. 189 48th Ave. from 23rd St. to S. of Bradshaw Park Entrance & Concrete Paving Improvements 2023			Contractor's Pay Application: 10								
Application Period: (From - To) 7/25/23 to 8/22/23											
A Item			B	C	D	E	F	G	H		I
Bid Item No.	Description	Unit of Measure	Bid Quantity	Unit Price	Bid Value (D*E)	Estimated Quantity Installed	Value Installed (G*E)	Material Presently Stored	Total Completed and Stored to Date (F+G)	% (F) B (H/F*100)	Balance to Finish (D - H)
PROJECT A: SID NO. 189 48 Ave. from 23 St. to S Bradshaw Park Entrance (CIP 23-25)											
1	Mobilization	JOB	1	\$ 75,000.00	\$ 75,000.00	1	\$ 75,000.00		\$ 75,000.00	100	\$ -
2	Traffic & Pedestrian Control, including Detour	JOB	1	\$ 10,000.00	\$ 10,000.00	1	\$ 10,000.00		\$ 10,000.00	100	\$ -
3	NPDES, SWPPP, & BMP Maintenance	JOB	1	\$ 8,000.00	\$ 8,000.00	1	\$ 8,000.00		\$ 8,000.00	100	\$ -
4	Curb or Grate Inlet Filter BMP	EA	20	\$ 200.00	\$ 4,000.00	20	\$ 4,000.00		\$ 4,000.00	100	\$ -
5	Remove & Mill Asphalt Paving	SY	6,704	\$ 8.00	\$ 53,632.00	6,928	\$ 55,424.00		\$ 55,424.00	103	\$ (1,792.00)
6	Remove Concrete Paving	SY	1,496	\$ 16.00	\$ 23,936.00	1,716	\$ 27,456.00		\$ 27,456.00	115	\$ (3,520.00)
7	Remove Culvert All Sizes Including Headwalls & FES	LF	350	\$ 12.00	\$ 4,200.00	400	\$ 4,800.00		\$ 4,800.00	114	\$ (600.00)
8	Remove Inlet	EA	2	\$ 1,000.00	\$ 2,000.00	2	\$ 2,000.00		\$ 2,000.00	100	\$ -
9	Remove Junction Box	EA	1	\$ 1,500.00	\$ 1,500.00	1	\$ 1,500.00		\$ 1,500.00	100	\$ -
10	Remove & Reset Stop Sign	EA	2	\$ 300.00	\$ 600.00	4	\$ 1,200.00		\$ 1,200.00	200	\$ (600.00)
11	Temporary Road Surfacing and Maintenance	JOB	1	\$ 50,000.00	\$ 50,000.00	1	\$ 50,000.00		\$ 50,000.00	100	\$ -
12	Remove Concrete Header	LF	33	\$ 25.00	\$ 825.00	33	\$ 825.00		\$ 825.00	100	\$ -
13	9-inch P.C. Concrete with 1 1/4" Doweled Paving NDOT Type 47B-3500	SY	9,460	\$ 65.00	\$ 614,900.00	9,524	\$ 619,060.00		\$ 619,060.00	101	\$ (4,160.00)
14	8-inch P.C. Concrete Driveway Paving NDOT Type 47B-3500	SY	47	\$ 65.00	\$ 3,055.00	44	\$ 2,860.00		\$ 2,860.00	94	\$ 195.00
15	6-inch P.C. Concrete Street Paving NDOT Type 47B-3500	SY	504	\$ 60.00	\$ 30,240.00	504	\$ 30,240.00		\$ 30,240.00	100	\$ -
16	6-inch P.C. Concrete Trail Paving, including Handicap Ramps, NDOT Type 47B-3500	SY	1,696	\$ 60.00	\$ 101,760.00	1,978	\$ 118,680.00		\$ 118,680.00	117	\$ (16,920.00)
17	6-inch P.C. Concrete Driveway Paving, NDOT Type 47B-3500	SY	601	\$ 60.00	\$ 36,060.00	411	\$ 24,660.00		\$ 24,660.00	68	\$ 11,400.00
18	5-inch P.C. Concrete Sidewalk Paving, NDOT Type 47B-3500	SY	335	\$ 75.00	\$ 25,125.00	374	\$ 28,050.00		\$ 28,050.00	112	\$ (2,925.00)
19	9-inch P.C. Concrete Street Paving, NDOT Type 47B-3500	SY	353	\$ 65.00	\$ 22,945.00	474	\$ 30,810.00		\$ 30,810.00	134	\$ (7,865.00)
20	1.5 Foot Concrete Header	LF	105	\$ 20.00	\$ 2,100.00	74	\$ 1,480.00		\$ 1,480.00	70	\$ 620.00
21	ADA Handicap Ramp Detectable Warning Panel	SF	216	\$ 38.00	\$ 8,208.00	260	\$ 9,880.00		\$ 9,880.00	120	\$ (1,672.00)
22	4-inch Aggregate Paving Subbase	SY	11,142	\$ 16.00	\$ 178,272.00	11,142	\$ 178,272.00		\$ 178,272.00	100	\$ -
23	Underdrain System, including 4-inch Perforated PVC Pipe, Rock, Fabric, Complete in Place	LF	4,780	\$ 14.00	\$ 66,920.00	4,780	\$ 66,920.00		\$ 66,920.00	100	\$ -
24	Adjust Manhole to Grade	EA	6	\$ 1,000.00	\$ 6,000.00	6	\$ 6,000.00		\$ 6,000.00	100	\$ -
25	Adjust Water Valve Box to Grade	EA	6	\$ 1,000.00	\$ 6,000.00	11	\$ 11,000.00		\$ 11,000.00	183	\$ (5,000.00)
26	Monument Well	EA	1	\$ 1,000.00	\$ 1,000.00	1	\$ 1,000.00		\$ 1,000.00	100	\$ -
TOTAL PAGE ONE (ITEMS 1-26)					\$ 1,336,278.00		\$ 1,369,117.00	\$ -	\$ 1,369,117.00		\$ (32,839.00)

Project SID No. 189 48th Ave. from 23rd St. to S. of Bradshaw Park Entrance & Name: Concrete Paving Improvements 2023					Contractor's Pay Application: 10						
Application Period: (From - To) 7/25/23 to 8/22/23											
A			B	C	D	E	F	G	H		I
Item			Bid Quantity	Unit Price	Bid Value (D*E)	Estimated Quantity Installed	Value Installed (G*E)	Material Presently Stored	Total Completed and Stored to Date (F+G)	% (F) B (H/F*100)	Balance to Finish (D - H)
Bid Item No.	Description	Unit of Measure									
PROJECT C: 36th Street from 48th to 50th Avenue (CIP 20-71)											
1	Mobilization	JOB	1	\$ 7,500.00	\$ 7,500.00	1	\$ 7,500.00		\$ 7,500.00	100	\$ -
2	Traffic & Pedestrian Control	JOB	1	\$ 5,000.00	\$ 5,000.00	1	\$ 5,000.00		\$ 5,000.00	100	\$ -
3	Curb or Grate Inlet Filter BMP	EA	6	\$ 300.00	\$ 1,800.00	6	\$ 1,800.00		\$ 1,800.00	100	\$ -
4	Remove Paving, including Sawing	SY	3,997	\$ 18.00	\$ 71,946.00	4,028	\$ 72,504.00		\$ 72,504.00	101	\$ (558.00)
5	Remove & Rebuild Inlet (and 3 Junction Boxes)	EA	6	\$ 4,500.00	\$ 27,000.00	9	\$ 40,500.00		\$ 40,500.00	150	\$ (13,500.00)
6	Remove & Reset Mailbox	EA	4	\$ 600.00	\$ 2,400.00	7	\$ 4,200.00		\$ 4,200.00	175	\$ (1,800.00)
7	Temporary Aggregate Surfacing Driveways (Sidewalks west end and 12" RCP pipe)	JOB	1	\$ 10,000.00	\$ 10,000.00	1	\$ 10,000.00		\$ 10,000.00	100	\$ -
8	7-inch P.C. Concrete Paving, NDOT Type 47B-3500	SY	3,758	\$ 66.00	\$ 248,028.00	3,786	\$ 249,876.00		\$ 249,876.00	101	\$ (1,848.00)
9	6-inch P.C. Concrete Driveway Paving NDOT Type 47B-3500	SY	239	\$ 66.00	\$ 15,774.00	242	\$ 15,972.00		\$ 15,972.00	101	\$ (198.00)
10	Adjust Manhole to Grade (1 Valve Box)	EA	3	\$ 1,000.00	\$ 3,000.00	0.75	\$ 750.00		\$ 750.00	25	\$ 2,250.00
11	Over Excavation & Crushed Concrete	TON	50	\$ 75.00	\$ 3,750.00		\$ -		\$ -	0	\$ 3,750.00
12	Earthwork, Final Grading, Backfilling, & Shaping	JOB	1	\$ 20,000.00	\$ 20,000.00	1	\$ 20,000.00		\$ 20,000.00	100	\$ -
13	Sodding, Watering, & Maintenance	SF	12,192	\$ 2.75	\$ 33,528.00	11,200	\$ 30,800.00		\$ 30,800.00	92	\$ 2,728.00
GRAND TOTAL PROJECT C (ITEMS 1-13)					\$ 449,726.00		\$ 458,902.00		\$ 458,902.00		\$ (9,176.00)
ADDITIONAL PROJECT NO. 1: 40th Avenue from 27th Street to the North (CIP 20-71)											
1	Mobilization	JOB	1	\$ 7,500.00	\$ 7,500.00	1	\$ 7,500.00		\$ 7,500.00	100	\$ -
2	Traffic & Pedestrian Control	JOB	1	\$ 5,000.00	\$ 5,000.00	1	\$ 5,000.00		\$ 5,000.00	100	\$ -
3	Curb or Grate Inlet Filter BMP	EA	4	\$ 300.00	\$ 1,200.00		\$ -		\$ -	0	\$ 1,200.00
4	Remove Paving, including Sawing	SY	2,600	\$ 18.00	\$ 46,800.00	2,592	\$ 46,656.00		\$ 46,656.00	100	\$ 144.00
5	Remove & Reset Mailbox	EA	12	\$ 600.00	\$ 7,200.00	1	\$ 600.00		\$ 600.00	8	\$ 6,600.00
6	Temporary Aggregate Surfacing Driveways (sidewalks, repair of inlet, 2025 casting)	JOB	1	\$ 10,000.00	\$ 10,000.00	0.460	\$ 4,600.00		\$ 4,600.00	46	\$ 5,400.00
7	7-inch P.C. Concrete Paving, NDOT Type 47B-3500	SY	2,372	\$ 70.00	\$ 166,040.00	2,372	\$ 166,040.00		\$ 166,040.00	100	\$ -
8	6-inch P.C. Concrete Driveway Paving NDOT Type 47B-3500	SY	220	\$ 70.00	\$ 15,400.00	220	\$ 15,400.00		\$ 15,400.00	100	\$ -
9	Adjust Manhole to Grade	EA	2	\$ 1,000.00	\$ 2,000.00	2	\$ 2,000.00		\$ 2,000.00	100	\$ -
10	Over Excavation & Crushed Concrete	TON	50	\$ 75.00	\$ 3,750.00	622	\$ 46,650.00		\$ 46,650.00	1244	\$ (42,900.00)
11	Earthwork, Final Grading, Backfilling, & Shaping	JOB	1	\$ 10,000.00	\$ 10,000.00	1	\$ 10,000.00		\$ 10,000.00	100	\$ -
12	Sodding, Watering, & Maintenance	SF	7,712	\$ 2.75	\$ 21,208.00	2,800	\$ 7,700.00		\$ 7,700.00	36	\$ 13,508.00
GRAND TOTAL ADDITIONAL PROJECT NO. 1 (ITEMS 1-12)					\$ 296,098.00		\$ 312,146.00		\$ 312,146.00		\$ (16,048.00)
GRAND TOTAL PROJECTS A, B, C, & ADDITIONAL PROJECT NO. 1					\$ 3,613,722.25		\$ 3,402,598.75		\$ 3,402,598.75		\$ 211,123.50

AIA Type Document
Application and Certification for Payment

TO (OWNER): City of Columbus
2424 14th Street
PO Box 1677
Columbus, NE 68602-167

PROJECT: Columbus Pawnee Park

APPLICATION NO: 3 Final
PERIOD TO: 8/10/2023

DISTRIBUTION TO:
_ OWNER
_ ARCHITECT
_ CONTRACTOR

FROM (CONTRACTOR): Nemaha Landscape Const., Inc.
541 S 1st ST
Lincoln, NE 68508

VIA (ARCHITECT):

ARCHITECT'S PROJECT NO:

CONTRACT FOR: Pawnee Park- Turf Replacement

CONTRACT DATE: 5/11/2023

CONTRACTOR'S APPLICATION FOR PAYMENT

Application is made for Payment, as shown below, in connection with the Contract. Continuation Sheet, AIA Type Document is attached.

1. ORIGINAL CONTRACT SUM	\$	579,000.00
2. Net Change by Change Orders	\$	-15,100.00
3. CONTRACT SUM TO DATE (Line 1 + 2)	\$	563,900.00
4. TOTAL COMPLETED AND STORED TO DATE	\$	563,900.00
5. RETAINAGE:		
a. 0.00 % of Completed Work	\$	0.00
b. 0.00 % of Stored Material	\$	0.00
Total retainage (Line 5a + 5b)	\$	0.00
6. TOTAL EARNED LESS RETAINAGE	\$	563,900.00
(Line 4 less Line 5 Total)		
7. LESS PREVIOUS CERTIFICATES FOR PAYMENT		
(Line 6 from prior Certificate)	\$	506,000.00
8. CURRENT PAYMENT DUE	\$	57,900.00
9. BALANCE TO FINISH, INCLUDING RETAINAGE		
(Line 3 less Line 6)	\$	0.00

CHANGE ORDER SUMMARY	ADDITIONS	DEDUCTIONS
Total changes approved in previous months by Owner	0.00	0.00
Total approved this Month	0.00	-15,100.00
TOTALS	0.00	-15,100.00
NET CHANGES by Change Order		-15,100.00

The Undersigned Contractor certifies that to the best of the Contractor's knowledge, information and belief the work covered by this application for Payment has been completed in accordance with the Contract Documents, that all amounts have been paid by the Contractor for Work for which previous Certificates for Payment were issued and payments received from the owner, and that current payment shown herein is now due.

CONTRACTOR: Nemaha Landscape Const., Inc.
541 S 1st ST Lincoln, NE 68508

By: [Signature] Date: 8/10/23



State of: NE
County of: Lancaster
Subscribed and Sworn to before me this 10th Day of August 2023
Notary Public: [Signature]
My Commission Expires: 11/14/26

ARCHITECT'S CERTIFICATE FOR PAYMENT

In Accordance with the Contract Documents, based on on-site observations and the data comprising the above application, the Architect certifies to owner that to the best of the Architect's knowledge, information and belief the Work has progressed as indicated, the quality of the work is in accordance with the Contract Documents, and the Contractor is entitled to payment of the AMOUNT CERTIFIED.

AMOUNT CERTIFIED \$ 57,900.00

(Attach explanation if amount certified differs from the amount applied. Initial all figures on this Application and on the Continuation Sheet that are changed to conform to the amount certified.)

ARCHITECT: [Signature] Date: 8-29-2023

This Certificate is not negotiable. The AMOUNT CERTIFIED is payable only to the Contractor named herein. Issuance, Payment and acceptance of payment are without prejudice to any rights of the Owner or Contractor under this Contract.

AIA Type Document
Application and Certification for Payment

TO (OWNER): City of Columbus
 2424 14th Street
 PO Box 1677
 Columbus, NE 68602-167

PROJECT: Columbus Pawnee Park

APPLICATION NO: Final
PERIOD TO: 8/10/2023

DISTRIBUTION TO:
 _ OWNER
 _ ARCHITECT
 _ CONTRACTOR

FROM (CONTRACTOR): Nemaha Landscape Const., Inc.
 541 S 1st ST
 Lincoln, NE 68508

VIA (ARCHITECT):

ARCHITECT'S PROJECT NO:

CONTRACT FOR: Pawnee Park- Turf Replacement

CONTRACT DATE: 5/11/2023

ITEM	DESCRIPTION	SCHEDULE VALUE	PREVIOUS APPLICATIONS	COMPLETED THIS PERIOD	STORED MATERIAL	COMPLETED STORED	%	BALANCE	RETAINAGE
1	Mobilizations	6,100.00	6,100.00	0.00	0.00	6,100.00	100.00	0.00	0.00
2	Project Start-up (Meetings & Submittals, etc.)	3,000.00	3,000.00	0.00	0.00	3,000.00	100.00	0.00	0.00
3	Bonds/Insurance	7,400.00	7,400.00	0.00	0.00	7,400.00	100.00	0.00	0.00
4	Project Supervision	14,200.00	14,200.00	0.00	0.00	14,200.00	100.00	0.00	0.00
5	Engineering Reviews	4,300.00	4,300.00	0.00	0.00	4,300.00	100.00	0.00	0.00
6	Track Crossing/Protection	2,500.00	2,500.00	0.00	0.00	2,500.00	100.00	0.00	0.00
7	Layout & Conformance	3,000.00	3,000.00	0.00	0.00	3,000.00	100.00	0.00	0.00
8	Removals	62,000.00	62,000.00	0.00	0.00	62,000.00	100.00	0.00	0.00
9	Grading & Nailer	18,000.00	18,000.00	0.00	0.00	18,000.00	100.00	0.00	0.00
10	Electrical Boxes	5,500.00	5,500.00	0.00	0.00	5,500.00	100.00	0.00	0.00
11	Clean-Up	3,000.00	3,000.00	0.00	0.00	3,000.00	100.00	0.00	0.00
12	Closeout	2,000.00	2,000.00	0.00	0.00	2,000.00	100.00	0.00	0.00
13	Turf Base Bid	430,500.00	430,500.00	0.00	0.00	430,500.00	100.00	0.00	0.00
14	Soccer Lines	6,400.00	6,400.00	0.00	0.00	6,400.00	100.00	0.00	0.00
15	Logo	11,100.00	11,100.00	0.00	0.00	11,100.00	100.00	0.00	0.00
16	Credit- Logo	-11,100.00	-11,100.00	0.00	0.00	-11,100.00	100.00	0.00	0.00
17	Credit- Electrical Boxes	-2,500.00	-2,500.00	0.00	0.00	-2,500.00	100.00	0.00	0.00
18	Credit- Nailer Board	-1,500.00	-1,500.00	0.00	0.00	-1,500.00	100.00	0.00	0.00
REPORT TOTALS		\$563,900.00	\$563,900.00	\$0.00	\$0.00	\$563,900.00	100.00	\$0.00	\$0.00

4.D. Payroll and bills on file.

Vendor Code Post Date	Vendor Name Activity	Inv/Check #	Description	Invoice Amt	Check Amt
02359 09/06/2023	911 CUSTOM LLC INVOICE	53662	BLACKINTON FLEX BADGE - MCCLOUD QM	37.00	
			Total:	37.00	
			Net of 1 Invoices / 0 Checks	37.00	
10741 09/06/2023	ABSALON ROBERT INVOICE	8.21.2023	GRAND ISLAND GRADE 2 CLASS - REIMBURSE MEAL:	95.78	
			Total:	95.78	
			Net of 1 Invoices / 0 Checks	95.78	
00116 09/06/2023	ACE HARDWARE & GARDEN CNT INVOICE	196893/5	NUTS, BOLTS, SCREWS	9.54	
09/06/2023	INVOICE	196903/5	BATTERIES, ELEC TAPE, FUSES	38.57	
09/06/2023	INVOICE	196900/5	FLAP DISC, BLADE FUSES	27.16	
09/06/2023	INVOICE	196596/5	PRUNER	34.23	
09/06/2023	INVOICE	196591/5	CABLE TIES	6.58	
09/06/2023	INVOICE	196584/5	NUTS, BOLTS, EXT FLAT WHITE PAINT	53.74	
09/06/2023	INVOICE	196558/5	GATORLINE	13.99	
09/06/2023	INVOICE	196672/5	NUTS, BOLTS, SCREWS	4.20	
09/06/2023	INVOICE	196633/5	AIR FILTER	9.99	
09/06/2023	INVOICE	196631/5	BLOW OFF DUSTER	13.99	
09/06/2023	INVOICE	196626/5	AA BATTERIES	13.99	
09/06/2023	INVOICE	196668/5	FLEX TAPE	14.99	
09/06/2023	INVOICE	196641/5	INDOOR INSERT KILLER	25.99	
09/06/2023	INVOICE	196640/5	KEY SCHLAGE	5.98	
09/06/2023	INVOICE	196644/5	EXT FLAT WHITE	42.79	
09/06/2023	INVOICE	196718/5	PROPANE	91.23	
09/06/2023	INVOICE	196741/5	SWVL FL UNION, TUBE STRAP	14.67	
09/06/2023	INVOICE	196760/5	AM/FM CLOCK RADIO	12.99	
09/06/2023	INVOICE	196758/5	CARB ZAMA	37.19	
09/06/2023	INVOICE	196751/5	INSECT KILLER	29.94	
09/06/2023	INVOICE	196727/5	INSECT KILLER, SPRAYER, BOWL BRUSH	41.69	
09/06/2023	INVOICE	196704/5	LEAF RAKE, NUTS, BOLTS, SCREWS	41.48	
09/06/2023	INVOICE	196793/5	LIGHT BULBS	48.14	
09/06/2023	INVOICE	196761/5	BATTERIES	16.99	
09/06/2023	INVOICE	196683/5	PADLOCK	15.99	
09/06/2023	INVOICE	196767/5	STIHL MS 194, 14" & 18" CHAIN	552.97	
09/06/2023	INVOICE	196780/5	NUTS, BOLTS, SCREWS	1.38	
09/06/2023	INVOICE	196776/5	CLEANSER, PUTTY EPOXY TANKWELD, GORILLA GLU	20.15	
09/06/2023	INVOICE	196819/5	KEY SCHLAGE	17.94	
09/06/2023	INVOICE	196838/5	TORX BIT SOCKET SET	54.98	
09/06/2023	INVOICE	196886/5	SILICONE W&D, ACE RSTP SPRAY	38.15	
			Total:	1,351.61	
			Net of 31 Invoices / 0 Checks	1,351.61	
10370 09/06/2023	ADDEPT MEDIA LLC INVOICE	81891	HUMPHREY DEMOCRAT	100.00	
			Total:	100.00	
			Net of 1 Invoices / 0 Checks	100.00	
00180 09/06/2023	ADVANCE AUTO PARTS INVOICE	5606322867003	OIL FILTER	2.62	
09/06/2023	INVOICE	5606323419179	20 QT DRAIN PAN	10.99	

Vendor Code Post Date	Vendor Name Activity	Inv/Check #	Description	Invoice Amt	Check Amt
09/06/2023	INVOICE	5606323419178	OIL FILTER, 15W-40, CP WRENCH, FREON	137.83	
09/06/2023	INVOICE	5606323451528	RADIATOR FAN	134.46	
09/06/2023	INVOICE	5606323436080	PROFESSIONAL GAUGE, R134 MAX COOL, FREON	75.85	
09/06/2023	INVOICE	5606322366843	5.4 LONG BLOCK	4,175.00	
09/06/2023	INVOICE	5606323667263	OIL FILTER, AIR FILTER	15.21	
09/06/2023	INVOICE	5606323667262	OIL FILTER	27.64	
09/06/2023	INVOICE	5606320065990	LUBE	6.47	
Total:				4,586.07	
Net of 9 Invoices / 0 Checks				4,586.07	
10420	AKRS EQUIPMENT				
09/06/2023	INVOICE	3594210	TOOLBOX	59.83	
09/06/2023	INVOICE	3590127	FUEL PUMP	96.62	
Total:				156.45	
Net of 2 Invoices / 0 Checks				156.45	
00133	AMERICAN LEGAL PUBLISHING CORP				
09/06/2023	INVOICE	27372	INTERNET RENEWAL PERIOD: 9/27/2023-9/27/202	495.00	
Total:				495.00	
Net of 1 Invoices / 0 Checks				495.00	
01189	AMERICAN RED CROSS				
09/06/2023	INVOICE	22604591	LIFEGUARDING & WATERPARK SKILLS, CPR/AED FOI	187.00	
Total:				187.00	
Net of 1 Invoices / 0 Checks				187.00	
10930	AOI CORPORATION				
09/06/2023	INVOICE	27103	CREDENZA	5,895.68	
09/06/2023	INVOICE	27282	HERMAN MILLER	37.83	
09/06/2023	INVOICE	27125	PENCIL DRAWERS	409.53	
09/06/2023	INVOICE	172426	DRILL GROMMET & MICROPHONE HOLES, INSTALL GI	1,040.00	
Total:				7,383.04	
Net of 4 Invoices / 0 Checks				7,383.04	
00045	APCO INTERNATIONAL				
09/06/2023	INVOICE	00079039	APCO INTELLICOMM SOFTWARE, EMD PRODUCTION GI	17,717.22	
Total:				17,717.22	
Net of 1 Invoices / 0 Checks				17,717.22	
11065	ARCHIVESOCIAL LLC				
09/06/2023	INVOICE	29671	SOCIAL MEDIA ARCHIVING SUBSCRIPTION	1,797.00	
Total:				1,797.00	
Net of 1 Invoices / 0 Checks				1,797.00	
10561	ARNOLD MOTOR SUPPLY				
09/06/2023	INVOICE	78NV080527	SERRATED WHEEL STUD	11.84	
09/06/2023	INVOICE	78NV079811	4 - CLR/MKR LAMPS	11.16	
09/06/2023	INVOICE	78NV079933	4GE-6FJX	41.12	
09/06/2023	INVOICE	78NV078863	AIR FILTER	39.82	

Vendor Code Post Date	Vendor Name Activity	Inv/Check #	Description	Invoice Amt	Check Amt
09/06/2023	INVOICE	78NV078948	AIR FILTER	61.80	
09/06/2023	INVOICE	78NV078969	AIR FILTER	25.47	
09/06/2023	INVOICE	78CR008992	CREDIT - AIR FILTER	(39.82)	
09/06/2023	INVOICE	78NV079003	BELT DRESSING & COND 60Z	5.19	
09/06/2023	INVOICE	78NV079903	HP V-BELT	14.84	
09/06/2023	INVOICE	78NV079942	6 - OIL SEALS	56.88	
09/06/2023	INVOICE	78NV079775	PRIME/ORG COMPAT 50/50, BRAKLEEN	71.50	
09/06/2023	INVOICE	78NV079737	CLR/MKR LAMP	5.58	
09/06/2023	INVOICE	78CR008972	RETURN - AIR FILTER	(67.13)	
09/06/2023	INVOICE	78NV078959	AIR FILTER	67.13	
Total:				305.38	
Net of 14 Invoices / 0 Checks				305.38	
10414	B2 ENVIRONMENTAL INC				
09/06/2023	INVOICE	30199	ASBESTOS ABATEMENT & HAZARDOUS MATERIALS REI	94,100.00	
Total:				94,100.00	
Net of 1 Invoices / 0 Checks				94,100.00	
MISC	BAKER PAUL				
09/06/2023	INVOICE	08/24/2023	UB refund for account: 400-80470-02	45.35	
Total:				45.35	
Net of 1 Invoices / 0 Checks				45.35	
03119	B-D CONSTRUCTION INC				
09/06/2023	INVOICE	2	SENIOR CENTER ENTRY RENO	24,404.40	
Total:				24,404.40	
Net of 1 Invoices / 0 Checks				24,404.40	
10435	BEST VERSION MEDIA, LLC				
09/06/2023	INVOICE	316377-202309	AD MANAGEMENT FEE	152.00	
09/06/2023	INVOICE	316377-202310	AD MANAGEMENT FEE	152.00	
Total:				304.00	
Net of 2 Invoices / 0 Checks				304.00	
11063	BIG PALS LITTLE PALS				
09/06/2023	INVOICE	30	19-DTR-101 CDBG #30	6,380.19	
Total:				6,380.19	
Net of 1 Invoices / 0 Checks				6,380.19	
00337	BOMGAARS				
09/06/2023	INVOICE	35191438	SPOTLIGHT, BATTERY, GLOVES	123.96	
09/06/2023	INVOICE	35192838	HOSE MENDER, HOSE CLAMP	7.07	
09/06/2023	INVOICE	35192804	LUBRICANT	15.16	
09/06/2023	INVOICE	35193025	MANIFOLD REPAIR, ELBOW	13.28	
09/06/2023	INVOICE	35193259	TRIMMER LINE	16.99	
09/06/2023	INVOICE	35194848	CLEVIS PIN	4.58	
09/06/2023	INVOICE	35195836	FLY TRAP, FLY RIBBON	9.48	
09/06/2023	INVOICE	35195866	GRINDER, PRESSURE CAP, ROTARY FILE	53.36	
09/06/2023	INVOICE	35195870	BULK BOLTS	13.21	
09/06/2023	INVOICE	35196428	FITTINGS	9.98	

Vendor Code Post Date	Vendor Name Activity	Inv/Check #	Description	Invoice Amt	Check Amt
09/06/2023	INVOICE	35200535	ANCHOR RING	15.98	
09/06/2023	INVOICE	35201885	TRIMMER LINE, OPTI-2 LUBRICANT	24.57	
09/06/2023	INVOICE	35202481	FASTENERS	11.16	
09/06/2023	INVOICE	35202323	TAPE MEASURE, FASTENING SET, SHOP TOWEL, CAI	56.95	
09/06/2023	INVOICE	35202800	SELF TENSION RATCHET	69.98	
09/06/2023	INVOICE	35203249	GLOVES	48.44	
09/06/2023	INVOICE	35205462	HOSE	25.92	
09/06/2023	INVOICE	35205919	GLOVES	40.98	
09/06/2023	INVOICE	35196230	DOG FOOD	99.98	
09/06/2023	INVOICE	35200539	CORNER BRACE	4.59	
09/06/2023	INVOICE	35198313	SILICONE SEALANT, FOAM TAPE, FASTENERS	25.53	
09/06/2023	INVOICE	35199321	SPRAY PAINT, PRIMER, BRUSH	50.25	
09/06/2023	INVOICE	35196273	BATTERY, SPOTLIGHTS	331.67	
Total:				1,073.07	
Net of 23 Invoices / 0 Checks				1,073.07	
00240	BOUND TREE MEDICAL LLC				
09/06/2023	INVOICE	85065878	NITRILE GLOVES	545.80	
09/06/2023	INVOICE	85068575	CURAPLEX EMESIS BAGS	26.49	
09/06/2023	INVOICE	85068574	TOGGLES FOR ALUMINUM D & JUMBO D CYLINDERS	219.90	
09/06/2023	INVOICE	85067224	FLUID SOLIDIFIER, BIOHAZARD BAG, BANDAGES, (43.05	
09/06/2023	INVOICE	85069898	CURAPLEX HOT PACK	12.93	
Total:				848.17	
Net of 5 Invoices / 0 Checks				848.17	
10626	CAPITAL ONE - WALMART				
09/06/2023	INVOICE	263200707927940	AIRHEADS, DAWN, STING-KILL, DIG TIMER	171.44	
09/06/2023	INVOICE	833205482474939	KA BURST, GRENADINE, SALT, PTZL RODS, LICOR.	41.60	
09/06/2023	INVOICE	923207524611397	FACE TISSUE, DAWN, PENS, GLUE TRAY, SPONGE,	161.94	
09/06/2023	INVOICE	493212482133796	SPONGE, SPAGHETTI, CANDY, OREOS	21.96	
09/06/2023	INVOICE	373215671397524	PARCHMENT PAPER, TREX MOUNT	21.22	
09/06/2023	INVOICE	503214477881789	BOB 4 PK, NERDS	29.46	
09/06/2023	INVOICE	393202494850355	DUM DUMS, CANDY, VIVA, LYSOL, CANOPY	118.46	
09/06/2023	INVOICE	303214561094010	FUN POPS, AIRHEADS	226.60	
Total:				792.68	
Net of 8 Invoices / 0 Checks				792.68	
00060	CDW GOVERNMENT				
09/06/2023	INVOICE	LF57600	SERVER LICENSES	23,827.84	
Total:				23,827.84	
Net of 1 Invoices / 0 Checks				23,827.84	
MISC	CHELOHA RICK				
09/06/2023	INVOICE	08/24/2023	UB refund for account: 300-56070-13	72.90	
Total:				72.90	
Net of 1 Invoices / 0 Checks				72.90	
01114	CIVIC PLUS				
09/06/2023	INVOICE	Q-43533-1	MEDIA CENTER STORAGE ANNUAL FEE, ANNUAL FEE	9,710.16	
Total:				9,710.16	

Vendor Code Post Date	Vendor Name Activity	Inv/Check #	Description	Invoice Amt	Check Amt
			Net of 1 Invoices / 0 Checks	9,710.16	
10816 09/06/2023	CLOSSON ROD INVOICE	8.10.2023	UMP: MEN'S LEAGUE TOURNAMENT 8/8, 8/9	180.00	
			Total:	180.00	
			Net of 1 Invoices / 0 Checks	180.00	
10906 09/06/2023	COLUMBUS MARINERS INVOICE	8.29.2023	BASEBALL MOUND RENTAL	500.00	
			Total:	500.00	
			Net of 1 Invoices / 0 Checks	500.00	
03143 09/06/2023	COLUMBUS TIRE & SERVICE INVOICE	1-26354	TIRE	119.54	
09/06/2023	INVOICE	1-26124	REPAIR TIRE	25.00	
09/06/2023	INVOICE	1-26168	REPAIR TIRE	25.00	
			Total:	169.54	
			Net of 3 Invoices / 0 Checks	169.54	
01250 09/06/2023	COMMONWEALTH ELECTRIC COMPANY INVOICE	12448	REPAIR SCOREBOARD	440.00	
			Total:	440.00	
			Net of 1 Invoices / 0 Checks	440.00	
11008 09/06/2023	CONFLUENCE INC INVOICE	27093	23009 PAWNEE PARK/GERRARD PARK RENOVATION P:	36,956.09	
			Total:	36,956.09	
			Net of 1 Invoices / 0 Checks	36,956.09	
11064 09/06/2023	CSH LLC INVOICE	2966	TEST PUMP	250.00	
			Total:	250.00	
			Net of 1 Invoices / 0 Checks	250.00	
01539 09/06/2023	D & K PRODUCTS INVOICE	70331IN	80 - EC 24-5-10 50% EPEC 90, 3% FE 50LB BAG:	1,960.00	
09/06/2023	INVOICE	70639IN	HERBICIDE & FUNGICIDE	3,232.00	
			Total:	5,192.00	
			Net of 2 Invoices / 0 Checks	5,192.00	
03279 09/06/2023	DAS STATE ACCOUNTING INVOICE	1387168	MONTHLY NETWORK CHARGES	256.00	
09/06/2023	INVOICE	1387218	MONTHLY NETWORK CHARGES	1,215.99	
			Total:	1,471.99	
			Net of 2 Invoices / 0 Checks	1,471.99	
MISC 09/06/2023	DELOZIER EUGENE INVOICE	08/24/2023	UB refund for account: 100-15880-01	38.72	

Vendor Code Post Date	Vendor Name Activity	Inv/Check #	Description	Invoice Amt	Check Amt
			Total:	38.72	
			Net of 1 Invoices / 0 Checks	38.72	
MISC 09/06/2023	DUREN DAVID INVOICE	08/29/2023	UB refund for account: 100-19160-00	3.09	
			Total:	3.09	
			Net of 1 Invoices / 0 Checks	3.09	
03158	EAKES OFFICE SOLUTIONS				
09/06/2023	INVOICE	8773035-0	CALENDARS	96.72	
09/06/2023	INVOICE	8779815-1	TONER	309.99	
09/06/2023	INVOICE	8777814-0	CENTER PULL TOWELS, ADHES NOTES	145.67	
09/06/2023	INVOICE	C8744243-0	RETURN - REEL, CARD W/CLIP	(298.32)	
09/06/2023	INVOICE	C8775778-0	RETURN - DESK CALENDAR	(16.29)	
09/06/2023	INVOICE	8781450-0	NAPKINS, PLATES, TOWELS	49.82	
09/06/2023	INVOICE	INV480930	COPIER CONTRACT	164.41	
09/06/2023	INVOICE	8776334-0	TONER	281.34	
09/06/2023	INVOICE	8775414-1	IJ CARDS	43.12	
09/06/2023	INVOICE	8775778-0	DESK CALENDAR	16.29	
09/06/2023	INVOICE	8775415-0	ROTARY CARD FILE	7.87	
09/06/2023	INVOICE	8775414-0	PRV FILTER	306.04	
09/06/2023	INVOICE	8771826-0	2X10 ACRYLIC PLATE - STACY SMITH	15.25	
09/06/2023	INVOICE	INV482726	COPIER	6,801.45	
09/06/2023	INVOICE	8779832-0	TONER	60.99	
09/06/2023	INVOICE	8779815-0	TONER	1,385.94	
			Total:	9,370.29	
			Net of 16 Invoices / 0 Checks	9,370.29	
03164	ERNST AUTO CENTER				
09/06/2023	INVOICE	9089929/1	OIL CHANGE, CABIN AIR FILTER VIN #4877	114.04	
09/06/2023	INVOICE	6119600	REPLACE FRONT BRAKE PADS & ROTOR VIN #5402	688.39	
			Total:	802.43	
			Net of 2 Invoices / 0 Checks	802.43	
MISC 09/06/2023	FIELD BLAINE P INVOICE	08/24/2023	UB refund for account: 300-55370-02	46.08	
			Total:	46.08	
			Net of 1 Invoices / 0 Checks	46.08	
MISC 09/06/2023	FISH JIM INVOICE	08/29/2023	UB refund for account: 100-06210-03	38.36	
			Total:	38.36	
			Net of 1 Invoices / 0 Checks	38.36	
MISC 09/06/2023	FITTJE LOREN INVOICE	08/29/2023	UB refund for account: 400-75910-01	51.35	
			Total:	51.35	
			Net of 1 Invoices / 0 Checks	51.35	
01997	FRONTIER COOPERATIVE COMPANY				

Vendor Code Post Date	Vendor Name Activity	Inv/Check #	Description	Invoice Amt	Check Amt
09/06/2023	INVOICE	S003179	CORN FOR TRAINING BIN	4,999.97	
			Total:	4,999.97	
			Net of 1 Invoices / 0 Checks	4,999.97	
03172	GALLS LLC				
09/06/2023	INVOICE	025348420	FLASHLIGHTS, BELT KEEPERS, CHAIN HANDCUFFS	575.25	
09/06/2023	INVOICE	025296636	REPLACEMENT PANTS	887.72	
09/06/2023	INVOICE	025228532	CARGO PANTS - HEESACKER QM	151.98	
09/06/2023	INVOICE	025124279	TACTICAL PANTS - JODI HEFTI QM	164.00	
			Total:	1,778.95	
			Net of 4 Invoices / 0 Checks	1,778.95	
01789	GAVER TIRE & AUTO CENTER INC				
09/06/2023	INVOICE	78194	CARLISLE INDUSTRIAL DEEP TRACTION	150.72	
09/06/2023	INVOICE	78214	4 - GENERAL GRABBER TIRES	904.83	
			Total:	1,055.55	
			Net of 2 Invoices / 0 Checks	1,055.55	
03174	GEHRING CONSTRUCTION &				
09/06/2023	INVOICE	71978	SL-1 CAULKING 300Z TUBE	469.20	
09/06/2023	INVOICE	71932	CRUSHED CONCRETE	1,288.00	
09/06/2023	INVOICE	71905	CRUSHED CONCRETE	1,849.00	
09/06/2023	INVOICE	71868	24" SONOTUBE, BURLAP, CEMENT TROWEL	651.08	
09/06/2023	INVOICE	71656	3281 51ST AVE	1,625.00	
09/06/2023	INVOICE	71634	18TH AVE & 6TH ST	789.41	
09/06/2023	INVOICE	71698	3281 51ST AVE	1,787.50	
09/06/2023	INVOICE	12039	12TH ST & 28TH AVE	49,541.00	
09/06/2023	INVOICE	10	SID #189 48TH AVE FROM 23RD ST TO S OF BRAD:	433,477.75	
			Total:	491,477.94	
			Net of 9 Invoices / 0 Checks	491,477.94	
03177	GENERAL TRAFFIC CONTROLS INC				
09/06/2023	INVOICE	23651	28 - 13' POLE ASSY	21,000.00	
			Total:	21,000.00	
			Net of 1 Invoices / 0 Checks	21,000.00	
03176	GEOCOMM INC				
09/06/2023	INVOICE	INV044762	GIS MAP DATA MAINTENANCE, MSAG & ALI DATA	5,766.00	
09/06/2023	INVOICE	INV044761	COLUMBUS/PLATTE MAINTENANCE SERVICES	11,733.00	
			Total:	17,499.00	
			Net of 2 Invoices / 0 Checks	17,499.00	
03178	GERHOLD CONCRETE COMPANY				
09/06/2023	INVOICE	408622	457 10TH AVE	168.62	
			Total:	168.62	
			Net of 1 Invoices / 0 Checks	168.62	
MISC	GILLETTE JO				
09/06/2023	INVOICE	08/29/2023	UB refund for account: 300-55710-00	85.07	

Vendor Code Post Date	Vendor Name Activity	Inv/Check #	Description	Invoice Amt	Check Amt
			Total:	85.07	
			Net of 1 Invoices / 0 Checks	85.07	
00056 09/06/2023	GODFATHER'S PIZZA INVOICE	6178	PIZZA	67.46	
			Total:	67.46	
			Net of 1 Invoices / 0 Checks	67.46	
MISC 09/06/2023	GRAHAM ANDREW INVOICE	08/24/2023	UB refund for account: 300-60990-01	44.04	
			Total:	44.04	
			Net of 1 Invoices / 0 Checks	44.04	
01373 09/06/2023	GRAINGER INVOICE	9803539569	MOTOR 1/8 HP	168.63	
			Total:	168.63	
			Net of 1 Invoices / 0 Checks	168.63	
02075 09/06/2023	GREAT PLAINS COMMUNICATIONS INVOICE	139461 4025648127	PHONE/INTERNET CHARGES 8/16-9/15	1,419.05	
			Total:	1,419.05	
			Net of 1 Invoices / 0 Checks	1,419.05	
10888 09/06/2023	GRIMES ASPHALT & PAVING CORP INVOICE	24658	COLD MIX	2,320.20	
			Total:	2,320.20	
			Net of 1 Invoices / 0 Checks	2,320.20	
MISC 09/06/2023	GRUBAUGH THOMAS CPA-PC INVOICE	08/24/2023	UB refund for account: 100-13480-01	3.15	
			Total:	3.15	
			Net of 1 Invoices / 0 Checks	3.15	
02904 09/06/2023	GUNSLINGERS LLC INVOICE	20942	OWB HOLSTER - UHL QM	49.99	
09/06/2023	INVOICE	20994	GLOCK 45 MOS & SIGHTS - SPILKER QM	720.00	
			Total:	769.99	
			Net of 2 Invoices / 0 Checks	769.99	
11017 09/06/2023	GUTIERREZ JUAN INVOICE	8.10.2023	UMP: MEN'S LEAGUE TOURNAMENT 8/8, 8/9	180.00	
			Total:	180.00	
			Net of 1 Invoices / 0 Checks	180.00	
03183 09/06/2023	HADLEY-BRAITHWAIT COMPANY INVOICE	229245	CENTER PULL TOWELS	117.90	
09/06/2023	INVOICE	226596	CASE 20J16	53.95	

Vendor Code Post Date	Vendor Name Activity	Inv/Check #	Description	Invoice Amt	Check Amt
			Total:	171.85	
			Net of 2 Invoices / 0 Checks	171.85	
00272 09/06/2023	HAWKINS INC INVOICE	6561587	CHEMICALS	6,156.14	
			Total:	6,156.14	
			Net of 1 Invoices / 0 Checks	6,156.14	
03185 09/06/2023	HDR ENGINEERING INC INVOICE	1200550938	WATER & WASTEWATER USER RATE STUDY	1,377.86	
09/06/2023	INVOICE	1200550997	LOST CREEK PARKWAY SEWER PROJECT - R21-130	8,886.62	
09/06/2023	INVOICE	1200550998	DESIGN & CONSTRUCTION LOST CREEK PKWY WTR M	4,905.30	
09/06/2023	INVOICE	1200551008	WATER SYSTEM HYDRAULIC MODEL & MASTER PLAN	67,470.00	
			Total:	82,639.78	
			Net of 4 Invoices / 0 Checks	82,639.78	
01122 09/06/2023	HOA SOLUTIONS INC INVOICE	11335	PROGRAMMING - ADDED PID BLOCK FOR HIGH DEMAN	2,238.00	
			Total:	2,238.00	
			Net of 1 Invoices / 0 Checks	2,238.00	
00150 09/06/2023	HOMETOWN LEASING INVOICE	12	COPIER LEASE PAYMENT	175.00	
			Total:	175.00	
			Net of 1 Invoices / 0 Checks	175.00	
MISC 09/06/2023	HOTTOVY TODD INVOICE	08/29/2023	UB refund for account: 400-74790-06	1.72	
			Total:	1.72	
			Net of 1 Invoices / 0 Checks	1.72	
MISC 09/06/2023	IENN JACKIE INVOICE	08/23/2023	UB refund for account: 300-55450-03	46.07	
			Total:	46.07	
			Net of 1 Invoices / 0 Checks	46.07	
03194 09/06/2023	INGRAM LIBRARY SERVICES, INC INVOICE	77235267	MATERIALS	652.01	
09/06/2023	INVOICE	77291124	MATERIALS	182.87	
09/06/2023	INVOICE	77358262	MATERIALS	65.66	
09/06/2023	INVOICE	77149026	MATERIALS	182.91	
			Total:	1,083.45	
			Net of 4 Invoices / 0 Checks	1,083.45	
00981 09/06/2023	INTERSTATE ALL BATTERY CENTER INVOICE	1905899022901	BATTERY	316.39	
			Total:	316.39	

Vendor Code Post Date	Vendor Name Activity	Inv/Check #	Description	Invoice Amt	Check Amt
			Net of 1 Invoices / 0 Checks	316.39	
00183 09/06/2023	INTOXIMETERS INC INVOICE	741714	REPAIR HANDHELD	312.90	
			Total:	312.90	
			Net of 1 Invoices / 0 Checks	312.90	
02609 09/06/2023	ISLAND SUPPLY WELDING CO. INVOICE	299214	ZIP WHEEL	24.22	
			Total:	24.22	
			Net of 1 Invoices / 0 Checks	24.22	
03199 09/06/2023	JACKSON SERVICES INC INVOICE	5119060	UNIFORMS	26.81	
09/06/2023	INVOICE	5119059	MAT	2.92	
09/06/2023	INVOICE	5119058	UNIFORMS	98.86	
09/06/2023	INVOICE	5119057	UNIFORMS	137.84	
09/06/2023	INVOICE	5119050	UNIFORMS	135.26	
09/06/2023	INVOICE	5119049	UNIFORMS	243.14	
09/06/2023	INVOICE	5114660	UNIFORMS	250.04	
09/06/2023	INVOICE	5112731	MATS	54.81	
09/06/2023	INVOICE	5112738	UNIFORMS	73.67	
09/06/2023	INVOICE	5117121	MAT	25.03	
09/06/2023	INVOICE	5117120	UNIFORMS	73.78	
09/06/2023	INVOICE	5117119	UNIFORMS	25.89	
09/06/2023	INVOICE	5114672	MAT, BAR TOWELS, SHOP TOWELS	23.79	
09/06/2023	INVOICE	5114670	MATS, ROLLER TOWELS, UNIFORMS	170.40	
09/06/2023	INVOICE	5114673	UNIFORMS	26.71	
09/06/2023	INVOICE	5114671	UNIFORMS	98.76	
09/06/2023	INVOICE	5114661	UNIFORMS	135.16	
09/06/2023	INVOICE	5120829	MATS, MOPS, POLISH TOWEL, WINDSHIELD WIPES,	133.84	
			Total:	1,736.71	
			Net of 18 Invoices / 0 Checks	1,736.71	
00532 09/06/2023	JEO CONSULTING GROUP INC INVOICE	143543	COLUMBUS FLOODPLAIN ADMINISTRATION SUPPORT	6,073.75	
09/06/2023	INVOICE	143542	COLUMBUS FLOOD MITIGATION & RESILIENCY PLAN	16,007.00	
			Total:	22,080.75	
			Net of 2 Invoices / 0 Checks	22,080.75	
10856 09/06/2023	JOHN E. REID & ASSOCIATES INC INVOICE	4F5B6F4C-0001	KYLE BLUNK-4 DAY THE REID TECHNIQUE OF INVE:	630.00	
			Total:	630.00	
			Net of 1 Invoices / 0 Checks	630.00	
03202 09/06/2023	KELLY SUPPLY COMPANY INVOICE	S12287398-0	GATES STEMS	67.04	
09/06/2023	INVOICE	S12287418-1	1/2 PVC FEMALE ADAPTER	48.46	
09/06/2023	INVOICE	S12287877-0	1/2 INSERT 90 ELL, 1/2 PVC SCH 80 COUP	29.04	
09/06/2023	INVOICE	S12287854-0	1-1/4 PVC 40 90 ELL, PVC 40 BUSH	8.37	
09/06/2023	INVOICE	S12287620-0	PVC BUSHING, TEE, COUP	58.96	

Vendor Code Post Date	Vendor Name Activity	Inv/Check #	Description	Invoice Amt	Check Amt
			Total:	211.87	
			Net of 5 Invoices / 0 Checks	211.87	
10470 09/06/2023	KIESLER POLICE SUPPLY INVOICE	SI104053	4 - GLOCK 45T 9MM TRAINING PISTOLS	1,816.00	
			Total:	1,816.00	
			Net of 1 Invoices / 0 Checks	1,816.00	
03205 09/06/2023	KIRKHAM MICHAEL & ASSOCIATES INVOICE	94210	CONSTRUCT 8-PLACE T-HANGER	14,813.34	
			Total:	14,813.34	
			Net of 1 Invoices / 0 Checks	14,813.34	
MISC 09/06/2023	KLUG IVY INVOICE	08/29/2023	UB refund for account: 400-65400-02	1.14	
			Total:	1.14	
			Net of 1 Invoices / 0 Checks	1.14	
03206 09/06/2023	KOCH EXCAVATING CO INC INVOICE	33137	BLACK MULCH	440.00	
			Total:	440.00	
			Net of 1 Invoices / 0 Checks	440.00	
10850 09/06/2023	K-T HEATING & AIR CONDITIONING, INC INVOICE	I6368	COMMERCIAL SERVICE CALL	393.75	
			Total:	393.75	
			Net of 1 Invoices / 0 Checks	393.75	
00012 09/06/2023	LAKEVIEW SMALL ENGINE INC INVOICE	051502	BELT - PUMP DRI	53.65	
09/06/2023	INVOICE	051557	BLADE, SCAG 21I	96.66	
			Total:	150.31	
			Net of 2 Invoices / 0 Checks	150.31	
MISC 09/06/2023	LANGENFIELD GENE INVOICE	08/29/2023	UB refund for account: 400-67230-00	38.69	
			Total:	38.69	
			Net of 1 Invoices / 0 Checks	38.69	
01183 09/06/2023	LARM (LEAGUE ASSOCIATION OF INVOICE	107980	ENDORSEMENT #25	(177.75)	
09/06/2023	INVOICE	82423	LIQUOR LIABILITY POLICY	1,454.00	
			Total:	1,276.25	
			Net of 2 Invoices / 0 Checks	1,276.25	
02596 09/06/2023	LAWSON PRODUCTS INVOICE	9310853530	MEGACRIMP FTG, NYLON CABLE TIES	214.94	

Vendor Code Post Date	Vendor Name Activity	Inv/Check #	Description	Invoice Amt	Check Amt
			Total:	214.94	
			Net of 1 Invoices / 0 Checks	214.94	
10539 09/06/2023	LEVEL ONE PROPERTIES INVOICE	30	19-DTR-101CDBG #30	3,283.82	
			Total:	3,283.82	
			Net of 1 Invoices / 0 Checks	3,283.82	
10932 09/06/2023	LIBRARY FURNITURE INTERNATIONAL INVOICE	8614	LLC 50% DEPOSIT	4,200.00	
			Total:	4,200.00	
			Net of 1 Invoices / 0 Checks	4,200.00	
00103 09/06/2023 09/06/2023	LINCOLN JOURNAL STAR INVOICE INVOICE	118-60106294 118-60106294	WEEKLY AD ADVERTISING	386.54 1,149.57	
			Total:	1,536.11	
			Net of 2 Invoices / 0 Checks	1,536.11	
00822 09/06/2023 09/06/2023 09/06/2023 09/06/2023	LINCOLN WINWATER WORKS INVOICE INVOICE INVOICE INVOICE	09522901 09523001 09523201 09523202	8 - MACRO REPLACEMENT 8 - FERNCO SEWER MAIN REPAIR PARTS MAIN REPAIR PARTS	3,818.46 695.38 867.53 1,263.88	
			Total:	6,645.25	
			Net of 4 Invoices / 0 Checks	6,645.25	
03215 09/06/2023	M & O DOOR PRODUCTS INVOICE	IN104383	STAMP KEYS	15.64	
			Total:	15.64	
			Net of 1 Invoices / 0 Checks	15.64	
03217 09/06/2023 09/06/2023 09/06/2023 09/06/2023 09/06/2023 09/06/2023 09/06/2023 09/06/2023 09/06/2023 09/06/2023 09/06/2023	MAILBOX INVOICE INVOICE INVOICE INVOICE INVOICE INVOICE INVOICE INVOICE INVOICE INVOICE INVOICE	116444 116483 116523 116532 116581 116437 116455 116465 116476 116543	NEBRASKA PUBLIC HEALTH NEBRASKA PUBLIC HEALTH NEBRASKA PUBLIC HEALTH NEBRASKA PUBLIC HEALTH NEBRASKA PUBLIC HEALTH NEBRASKA LAW ENFORCEMENT CENTER STANARD & ASSOCIATES GENERAL TRAFFIC CONTROLS NEBRASKA PUBLIC HEALTH BETH KRAMER	12.50 38.54 12.54 12.51 12.50 13.54 12.52 41.68 12.51 6.38	
			Total:	175.22	
			Net of 10 Invoices / 0 Checks	175.22	
03220 09/06/2023 09/06/2023 09/06/2023	MENARDS INVOICE INVOICE INVOICE	92232 92239 92067	BAR & CHAIN LUBE, REDUC BUSHING, LOCKNUT RIVETS, FENDER WASHER, DAWN, DE-BUG, WINDSH: 10CT CONTRACTOR BAGS	12.95 75.77 23.56	

Vendor Code Post Date	Vendor Name Activity	Inv/Check #	Description	Invoice Amt	Check Amt
09/06/2023	INVOICE	91977	POWER TOOL ADAPTER, 1X4-3' BOARD	8.41	
09/06/2023	INVOICE	91821	GALV NIPPLES, ST ELBOWS	10.95	
09/06/2023	INVOICE	91819	100 PC NUT & BOLT ASST	1.49	
09/06/2023	INVOICE	91815	WHITE PEX TUBE, SAFETY VEST, INSECT SPRAY, 1	50.02	
09/06/2023	INVOICE	91881	50:1 FUEL PREMIX, 10CT CONTRACTOR BAGS	64.96	
09/06/2023	INVOICE	91892	WD-40, ROUND BASE MAGNET	17.95	
09/06/2023	INVOICE	91870	FIP ADAPTER	9.18	
Total:				275.24	
Net of 10 Invoices / 0 Checks				275.24	
03222	MID-AMERICAN RESEARCH				
09/06/2023	INVOICE	0798136-IN	SEWER SOLVNET, VEG-A-KILL, WIPE OUT 25# BAG,	2,856.50	
09/06/2023	INVOICE	0797996-IN	BOWL CLEANER	150.00	
Total:				3,006.50	
Net of 2 Invoices / 0 Checks				3,006.50	
02245	MID-IOWA SOLID WASTE				
09/06/2023	INVOICE	59168	4-SEGMENT GUTTER BROOM	506.40	
Total:				506.40	
Net of 1 Invoices / 0 Checks				506.40	
00205	MID-STATE ENGINEERING & TESTING				
09/06/2023	INVOICE	518-0	LOST CREEK PARKWAY SEWER & WATERMAIN	128.50	
Total:				128.50	
Net of 1 Invoices / 0 Checks				128.50	
10309	MIDWEST ALARM SERVICES				
09/06/2023	INVOICE	420317	FIRE ALARM MONITORING	540.00	
09/06/2023	INVOICE	416617	FIRE ALARM MONITORING- 424 8TH ST	420.00	
Total:				960.00	
Net of 2 Invoices / 0 Checks				960.00	
10976	MIDWEST PETROLEUM EQUIPMENT LLC				
09/06/2023	INVOICE	31071T	CARD READER INOPERABLE	394.75	
Total:				394.75	
Net of 1 Invoices / 0 Checks				394.75	
03226	MIDWEST SERVICE & SALES CO				
09/06/2023	INVOICE	0034223	DOUBLE BEVEL CURVE HEAT TREATED CARBIDE & S'	4,615.12	
Total:				4,615.12	
Net of 1 Invoices / 0 Checks				4,615.12	
00487	MIDWEST TAPE LLC				
09/06/2023	INVOICE	504230189	MATERIALS	208.40	
09/06/2023	INVOICE	504263617	MATERIALS	99.71	
Total:				308.11	
Net of 2 Invoices / 0 Checks				308.11	

Vendor Code Post Date	Vendor Name Activity	Inv/Check #	Description	Invoice Amt	Check Amt
03227	MIDWEST TURF & IRRIGATION				
09/06/2023	INVOICE	3917472-00	STARTER	454.78	
09/06/2023	INVOICE	3917084-00	RELAY	74.71	
09/06/2023	INVOICE	3916938-00	RELAY	45.08	
			Total:	574.57	
			Net of 3 Invoices / 0 Checks	574.57	
MISC	MILLER KATHLEEN				
09/06/2023	INVOICE	08/24/2023	UB refund for account: 300-49540-11	3.57	
			Total:	3.57	
			Net of 1 Invoices / 0 Checks	3.57	
MISC	MOHR CHRISTIAN				
09/06/2023	INVOICE	08/29/2023	UB refund for account: 100-10580-19	3.53	
			Total:	3.53	
			Net of 1 Invoices / 0 Checks	3.53	
10752	MOMS & MOPS				
09/06/2023	INVOICE	8.28.2023	CLEANING CENTRAL MAINTENANCE	320.00	
			Total:	320.00	
			Net of 1 Invoices / 0 Checks	320.00	
03230	MOTION INDUSTRIES INC				
09/06/2023	INVOICE	NE07-00493703	NITRILE DISP GLOVES	65.12	
09/06/2023	INVOICE	NE07-00494022	ELEMENT	922.64	
			Total:	987.76	
			Net of 2 Invoices / 0 Checks	987.76	
02622	MOTOROLA SOLUTIONS INC.				
09/06/2023	INVOICE	8230422218	5 YEAR MAINTENANCE & SUPPORT CONTRACT	54,947.48	
			Total:	54,947.48	
			Net of 1 Invoices / 0 Checks	54,947.48	
10832	MR GOLF CAR INC				
09/06/2023	INVOICE	41647	RENTAL/TOURNAMENT CARS 8/12/23	420.00	
09/06/2023	INVOICE	41650	RENTAL/TOURNAMENT CARS 8/14/23	6,060.00	
09/06/2023	INVOICE	41649	RENTAL/TOURNAMENT CARS 8/13/23	420.00	
			Total:	6,900.00	
			Net of 3 Invoices / 0 Checks	6,900.00	
00153	MUELLER SPRINKLERS				
09/06/2023	INVOICE	908863	72" EXTREME BLADES, BUSHING	56.10	
09/06/2023	INVOICE	908879	12 - HUNTER I 25 ADV	1,067.76	
			Total:	1,123.86	
			Net of 2 Invoices / 0 Checks	1,123.86	
00906	MUNICIPAL EMERGENCY SERVICES				
09/06/2023	INVOICE	IN1893166	DEX TURNOUT COATS & PANTS	20,730.00	

Vendor Code Post Date	Vendor Name Activity	Inv/Check #	Description	Invoice Amt	Check Amt
			Total:	20,730.00	
			Net of 1 Invoices / 0 Checks	20,730.00	
00210 09/06/2023	MUNICIPAL PIPE TOOL CO LLC INVOICE	33838	CONTROLLER	303.84	
			Total:	303.84	
			Net of 1 Invoices / 0 Checks	303.84	
10225 09/06/2023	NAPA AUTO PARTS OF COLUMBUS INVOICE	736109	CHUCK HD, GROMMET, LAMP	96.15	
09/06/2023	INVOICE	736245	BATTERY	41.23	
			Total:	137.38	
			Net of 2 Invoices / 0 Checks	137.38	
03233 09/06/2023	NEBRASKA LAW ENFORCEMENT INVOICE	12488	FEES - BALESTEN & FRENCH	284.00	
			Total:	284.00	
			Net of 1 Invoices / 0 Checks	284.00	
00444 09/06/2023	NEBRASKA PUBLIC HEALTH INVOICE	568197	WATER TESTING	2,235.00	
			Total:	2,235.00	
			Net of 1 Invoices / 0 Checks	2,235.00	
01286 09/06/2023	NEMAHA LANDSCAPE CONSTRUCTION INC INVOICE	3 FINAL	PAWNEE PARK TURF REPLACEMENT	57,900.00	
			Total:	57,900.00	
			Net of 1 Invoices / 0 Checks	57,900.00	
03241 09/06/2023	NEWMAN SIGNS INC. INVOICE	TRFINV048941	SIGNS	433.38	
09/06/2023	INVOICE	TRFINV048698	SIGNS	2,551.20	
			Total:	2,984.58	
			Net of 2 Invoices / 0 Checks	2,984.58	
10993 09/06/2023	NIEDBALSKI ROSS INVOICE	8.25.2023	MILEAGE - 4 STATE AIRPORT CONFERENCE KANSAS	360.25	
			Total:	360.25	
			Net of 1 Invoices / 0 Checks	360.25	
03246 09/06/2023	NORTHEAST NEBRASKA ECONOMIC INVOICE	24828	CDBG DHA REUSE JULY 2023 ADMIN SERVICES, DEI	203.50	
09/06/2023	INVOICE	24840	CDBG REHAB REUSE JULY 2023 ADMIN SERVICES	106.25	
09/06/2023	INVOICE	24849	DHA TRUST REUSE JULY 2023 ADMIN SERVICES	21.25	
			Total:	331.00	
			Net of 3 Invoices / 0 Checks	331.00	

Vendor Code Post Date	Vendor Name Activity	Inv/Check #	Description	Invoice Amt	Check Amt
00350 09/06/2023	NOSWETT FENCING INC INVOICE	14611	ADJUST GATE - IMPOUND YARD	175.00	
			Total:	175.00	
			Net of 1 Invoices / 0 Checks	175.00	
03249 09/06/2023	OCCUPATIONAL HEALTH SERV INVOICE	2874	COLLECTION & TESTING	594.00	
			Total:	594.00	
			Net of 1 Invoices / 0 Checks	594.00	
00176 09/06/2023	O'REILLY AUTOMOTIVE INC INVOICE	0681-238985	W/O GASKET	21.38	
09/06/2023	INVOICE	0681-237997	AIR FILTER	35.90	
09/06/2023	INVOICE	0681-238986	SPRAY PAINT, ENGINE PAINT	26.98	
09/06/2023	INVOICE	0681-238987	RETURN - SPRAY PAINT, ENGINE PAINT	(26.98)	
09/06/2023	INVOICE	0681-239515	SEAM SEALER, MASKING TAPE	75.29	
09/06/2023	INVOICE	0681-239323	TELE MIRROR	5.49	
			Total:	138.06	
			Net of 6 Invoices / 0 Checks	138.06	
03258 09/06/2023	PETTY CASH INVOICE	N7-2F2L-DD5J	VEHICLE TITLE/REGISTRATION	16.00	
			Total:	16.00	
			Net of 1 Invoices / 0 Checks	16.00	
00155 09/06/2023	PLATTE COUNTY INVOICE	REFUND	REFUND FOR OVER PAYMENT - E911 COUNTY	172,219.92	
			Total:	172,219.92	
			Net of 1 Invoices / 0 Checks	172,219.92	
00758 09/06/2023	PLATTE COUNTY REGISTER OF INVOICE	8232023	RESOLUTION R23-88, ORDINANCE 23-11	110.00	
			Total:	110.00	
			Net of 1 Invoices / 0 Checks	110.00	
00478 09/06/2023	PLATTE VALLEY HUMANE SOCIETY INVOICE	8.28.2023	50/50 PROCEEDS FROM THE PUPPY PLUNGE	400.00	
			Total:	400.00	
			Net of 1 Invoices / 0 Checks	400.00	
10241 09/06/2023	POMP'S TIRE SERVICE INC. INVOICE	1440018257	REPLACE RFO & RR DUALS ON TRAILER	307.61	
09/06/2023	INVOICE	1440018307	REPAIR TIRE	113.42	
09/06/2023	INVOICE	1440018431	REPAIR TIRE, USED TIRE	333.85	
			Total:	754.88	
			Net of 3 Invoices / 0 Checks	754.88	
02926	POWER TECH LLC				

Vendor Code Post Date	Vendor Name Activity	Inv/Check #	Description	Invoice Amt	Check Amt
09/06/2023	INVOICE	C002315	GENERATOR SERVICE AGREEMENT	970.00	
09/06/2023	INVOICE	W73356	GENERATOR CALL OUT - SOUTH PLANT	1,506.18	
09/06/2023	INVOICE	W73357	GENERATOR CALL OUT - CENTRAL MAINTENANCE	564.66	
			Total:	3,040.84	
			Net of 3 Invoices / 0 Checks	3,040.84	
03261	PRESTOX				
09/06/2023	INVOICE	49927861	PEST CONTROL - 4630 HOWARD BLVD	62.24	
			Total:	62.24	
			Net of 1 Invoices / 0 Checks	62.24	
10416	QUADIENT LEASING USA, INC.				
09/06/2023	INVOICE	N10076943	QUARTERLY MACHINE LEASE PAYMENT	642.63	
			Total:	642.63	
			Net of 1 Invoices / 0 Checks	642.63	
MISC	RANCHO PROPERTY MANAGEMENT LLC				
09/06/2023	INVOICE	08/23/2023	UB refund for account: 400-72940-03	22.33	
			Total:	22.33	
			Net of 1 Invoices / 0 Checks	22.33	
03264	REARDON LAWN & GARDEN INC				
09/06/2023	INVOICE	5291	AIR FILTER	5.99	
09/06/2023	INVOICE	5851	ROPE GUIDE	29.00	
09/06/2023	INVOICE	5984	BRUSHKNIFE, COLLAR NUT, RIDER PLATE	56.98	
			Total:	91.97	
			Net of 3 Invoices / 0 Checks	91.97	
10619	RIVER VALLEY TIRE SERVICE LLC				
09/06/2023	INVOICE	329727	2 - 19.5L 24 FIRESTONE ALL TRACTION	1,520.00	
			Total:	1,520.00	
			Net of 1 Invoices / 0 Checks	1,520.00	
10265	ROAD BUILDERS MACHINERY AND SUPPLY				
09/06/2023	INVOICE	S05641	KDPF EXCHANGE	4,461.59	
09/06/2023	INVOICE	S05659	O-RING, V-BELT, ELEMENT, CAP, CATRIDGE, FIL'	1,388.26	
			Total:	5,849.85	
			Net of 2 Invoices / 0 Checks	5,849.85	
MISC	ROBINSON DAX				
09/06/2023	INVOICE	08/24/2023	UB refund for account: 300-61678-02	40.75	
			Total:	40.75	
			Net of 1 Invoices / 0 Checks	40.75	
10793	SAND CREEK CONSTRUCTION COMPANY				
09/06/2023	INVOICE	137	CENTENNIAL PARK SPLASH PAD	16,600.00	
09/06/2023	INVOICE	136	GERRARD PARK TENNIS & PICKLEBALL COURT RENO'	20,246.18	

Vendor Code Post Date	Vendor Name Activity	Inv/Check #	Description	Invoice Amt	Check Amt
			Total:	36,846.18	
			Net of 2 Invoices / 0 Checks	36,846.18	
10569	SAYLER SCREENPRINTING				
09/06/2023	INVOICE	17397	NLECT UNIFORMS - BALESTERI	127.00	
09/06/2023	INVOICE	17396	NLETC UNIFORMS - FRENCH	127.00	
			Total:	254.00	
			Net of 2 Invoices / 0 Checks	254.00	
03271	SCHIEFFER SIGNS INC				
09/06/2023	INVOICE	46154	LOITERING PROHIBITED SIGNS	154.00	
			Total:	154.00	
			Net of 1 Invoices / 0 Checks	154.00	
10883	SCHOOL OUTFITTERS LLC				
09/06/2023	INVOICE	ORD11594867	2 - BOOK RETURN DROP CARTS	1,904.52	
			Total:	1,904.52	
			Net of 1 Invoices / 0 Checks	1,904.52	
02363	SCHUMACHER IRRIGATION INC				
09/06/2023	INVOICE	0269140-IN	2 - PIPES 8" SOCKET W/LEVER	871.70	
			Total:	871.70	
			Net of 1 Invoices / 0 Checks	871.70	
00465	SERVICEMASTER BY SHEVLIN				
09/06/2023	INVOICE	10355	JANITORIAL SERVICE	2,413.00	
09/06/2023	INVOICE	10348	JANITORIAL SERVICES	3,991.00	
09/06/2023	INVOICE	10351	JANITORIAL SERVICES	7,278.00	
			Total:	13,682.00	
			Net of 3 Invoices / 0 Checks	13,682.00	
02655	SHANE'S REPAIR				
09/06/2023	INVOICE	216	DIESEL CARE, DIESEL FUEL CLEANER	225.81	
			Total:	225.81	
			Net of 1 Invoices / 0 Checks	225.81	
MISC	SHELBY LUMBER				
09/06/2023	INVOICE	08/24/2023	UB refund for account: 400-72056-00	119.81	
09/06/2023	INVOICE	08/24/2023	UB refund for account: 400-72055-00	119.81	
09/06/2023	INVOICE	08/24/2023	UB refund for account: 200-42151-00	13.53	
			Total:	253.15	
			Net of 3 Invoices / 0 Checks	253.15	
03276	SHERWIN-WILLIAMS CO				
09/06/2023	INVOICE	8130-4	GLASS BEADS	1,306.00	
			Total:	1,306.00	
			Net of 1 Invoices / 0 Checks	1,306.00	

Vendor Code Post Date	Vendor Name Activity	Inv/Check #	Description	Invoice Amt	Check Amt
01394	SIRIUS COMPUTER SOLUTIONS INC.				
09/06/2023	INVOICE	INV-000968371	VMWARE VSPHERE, PRODUCTION SUPPORT	4,350.00	
09/06/2023	INVOICE	INV-000967515	WI-FI CITY PARKS - FRANKFORT SQ, STADIUM, P:	41,178.14	
09/06/2023	INVOICE	INV-000967354	GENERAL SUPPORT SERVICES	550.00	
09/06/2023	INVOICE	INV-000966963	COMMVAULT BACKUP & RECOVERY, SOFTWARE UPDATI	6,888.79	
			Total:	52,966.93	
			Net of 4 Invoices / 0 Checks	52,966.93	
01926	SMITH FERTILIZER GRAIN				
09/06/2023	INVOICE	4008033	BEET 55	7,358.11	
			Total:	7,358.11	
			Net of 1 Invoices / 0 Checks	7,358.11	
00244	STERICYCLE INC				
09/06/2023	INVOICE	4011990886	MEDICAL WASTE SERVICES	348.96	
			Total:	348.96	
			Net of 1 Invoices / 0 Checks	348.96	
10579	STREET COP TRAINING				
09/06/2023	INVOICE	INV-103876	NEBRASKA CASE LAW THAT ALL COPS NEED TO KNOW	199.00	
			Total:	199.00	
			Net of 1 Invoices / 0 Checks	199.00	
02937	SUBSURFACE SOLUTIONS				
09/06/2023	INVOICE	22565	LIVE CABLE CONNECTOR	600.33	
			Total:	600.33	
			Net of 1 Invoices / 0 Checks	600.33	
00105	SUPER SAVER				
09/06/2023	INVOICE	123210	BLEACH, GROCERIES	13.21	
09/06/2023	INVOICE	122863	GROCERIES	45.98	
09/06/2023	INVOICE	123195	GROCERIES	16.42	
			Total:	75.61	
			Net of 3 Invoices / 0 Checks	75.61	
03128	TIRE OUTLET INC				
09/06/2023	INVOICE	247914	REPAIR	35.00	
09/06/2023	INVOICE	248210	TUBE	7.50	
09/06/2023	INVOICE	248522	REPAIR	10.00	
			Total:	52.50	
			Net of 3 Invoices / 0 Checks	52.50	
01564	TOOLEY DRUG				
09/06/2023	INVOICE	01142796	CONTOUR NEXT	190.32	
			Total:	190.32	
			Net of 1 Invoices / 0 Checks	190.32	
00550	TRUCK CENTER COMPANIES				

Vendor Code Post Date	Vendor Name Activity	Inv/Check #	Description	Invoice Amt	Check Amt
09/06/2023	INVOICE	XA111031559:01	CAP-DEF TANK EXTENDED	38.33	
09/06/2023	INVOICE	XA111031297:01	REC M/C LIGHT/REFLECTOR AMBER	4.68	
09/06/2023	INVOICE	XA111031425:01	TITE-SEAL DOC HOLDER	19.54	
			Total:	62.55	
			Net of 3 Invoices / 0 Checks	62.55	
00357	TURFWERKS				
09/06/2023	INVOICE	OI55367	PROXIMITY , WLDMT COMP	456.53	
			Total:	456.53	
			Net of 1 Invoices / 0 Checks	456.53	
03294	USA BLUE BOOK				
09/06/2023	INVOICE	INV00101431	4-1/2" INSULATED PROBES	772.34	
09/06/2023	INVOICE	INV00100202	2" HONDA TRASH PUMP CAGE MOUNTED 163CC ENGI	1,484.71	
09/06/2023	INVOICE	INV00094475	Y-STRAINER; SOCKET	253.47	
			Total:	2,510.52	
			Net of 3 Invoices / 0 Checks	2,510.52	
02614	VACUUM CENTER				
09/06/2023	INVOICE	178267	BELTS	17.95	
			Total:	17.95	
			Net of 1 Invoices / 0 Checks	17.95	
11066	VAN IPEREN JEAN				
09/06/2023	INVOICE	8.01.2023	EXPENSES 2023 DOWNTOWN CONFERENCE SIOUX CIT'	548.11	
			Total:	548.11	
			Net of 1 Invoices / 0 Checks	548.11	
02280	VOICE HOUSE				
09/06/2023	INVOICE	0820	ADDITIONAL EXPENSES FOR ANDY WILLIAM ALL-ST/	300.00	
			Total:	300.00	
			Net of 1 Invoices / 0 Checks	300.00	
MISC	WOLLBERG RYAN & MELINDA				
09/06/2023	INVOICE	08/24/2023	UB refund for account: 400-67200-02	100.95	
			Total:	100.95	
			Net of 1 Invoices / 0 Checks	100.95	
MISC	WRIGHT ERIC				
09/06/2023	INVOICE	08/24/2023	UB refund for account: 300-56610-08	2.52	
			Total:	2.52	
			Net of 1 Invoices / 0 Checks	2.52	
MISC	ZABKA LORRAINE				
09/06/2023	INVOICE	08/29/2023	UB refund for account: 400-64420-02	33.85	
			Total:	33.85	
			Net of 1 Invoices / 0 Checks	33.85	

Vendor Code Post Date	Vendor Name Activity	Inv/Check #	Description	Invoice Amt	Check Amt
00215	ZIMCO SUPPLY CO				
09/06/2023	INVOICE	184544	SOD GROWER II	340.00	
09/06/2023	INVOICE	183745	REWARD 2.5 GAL AQUATIC HERBICIDE	240.00	
			Total:	580.00	
			Net of 2 Invoices / 0 Checks	580.00	
			invoices and 0 checks for 131 vendors:	1,415,045.19	

Inv Ref#	Vendor	Inv Date	Due Date	Inv Amt	Amt Due	Status	Jrnlized
91419	EAKES OFFICE SOLUTIONS	08/23/2023	09/06/2023	6,801.45	6,801.45	Open	N
91496	SIRIUS COMPUTER SOLUTIONS INC.	08/14/2023	09/06/2023	6,888.79	6,888.79	Open	N
91501	MR GOLF CAR INC	08/14/2023	09/06/2023	6,060.00	6,060.00	Open	N
91505	BIG PALS LITTLE PALS	08/24/2023	09/06/2023	6,380.19	6,380.19	Open	N
91640	JEO CONSULTING GROUP INC	08/18/2023	09/06/2023	6,073.75	6,073.75	Open	N
91642	HAWKINS INC	08/24/2023	09/06/2023	6,156.14	6,156.14	Open	N
91662	GEOCOMM INC	08/17/2023	09/06/2023	5,766.00	5,766.00	Open	N
91673	SMITH FERTILIZER GRAIN	08/24/2023	09/06/2023	7,358.11	7,358.11	Open	N
91694	SERVICEMASTER BY SHEVLIN	09/01/2023	09/06/2023	7,278.00	7,278.00	Open	N
91732	CIVIC PLUS	05/31/2023	09/06/2023	9,710.16	9,710.16	Open	N
91753	AOI CORPORATION	08/29/2023	09/06/2023	5,895.68	5,895.68	Open	N
91755	HDR ENGINEERING INC	08/29/2023	09/06/2023	8,886.62	8,886.62	Open	N
# of Invoices:	12	# Due:	12	Totals:	83,254.89	83,254.89	
# of Credit Memos:	0	# Due:	0	Totals:	0.00	0.00	
Net of Invoices and Credit Memos:					83,254.89	83,254.89	

--- TOTALS BY FUND ---

100 - GENERAL FUND	42,634.08	42,634.08
200 - STREETS/ENGINEERING	7,358.11	7,358.11
205 - AIRPORT	6,380.19	6,380.19
220 - COMMUNICATIONS - E911	5,766.00	5,766.00
500 - UTILITY SERVICE	8,886.62	8,886.62
520 - WATER	6,156.14	6,156.14
560 - STORMWATER UTILITY	6,073.75	6,073.75

--- TOTALS BY DEPT/ACTIVITY ---

000 -	6,380.19	6,380.19
100 - GENERAL ADMINISTRATION	18,485.57	18,485.57
130 - LIBRARY	18,088.51	18,088.51
156 - QUAIL RUN GOLF COURSE	6,060.00	6,060.00
200 - STREETS	7,358.11	7,358.11
220 - E911	5,766.00	5,766.00
500 - WASTEWATER COLLECTION	8,886.62	8,886.62
520 - WATER	6,156.14	6,156.14
560 - STORMWATER UTILITY	6,073.75	6,073.75

UNJOURNALIZED
 BOTH OPEN AND PAID

GL Number	Invoice Line Desc	Vendor	Invoice Description	Amount	Check #
Fund 100 GENERAL FUND					
Dept 100 GENERAL ADMINISTRATION					
100-100-53200	PROFESSIONAL SERVICES	AMERICAN LEGAL PUBLISHING	INTERNET RENEWAL PERIOD: 9/27/2023-9/27	495.00	
100-100-53400	COMPUTER SUPPORT/MAINT	ARCHIVESOCIAL LLC	SOCIAL MEDIA ARCHIVING SUBSCRIPTION	1,797.00	
100-100-53400	COMPUTER SUPPORT/MAINT	CDW GOVERNMENT	SERVER LICENSES	23,827.84	
100-100-53400	COMPUTER SUPPORT/MAINT	CIVIC PLUS	MEDIA CENTER STORAGE ANNUAL FEE, ANNUAI	9,710.16	
100-100-53400	COMPUTER SUPPORT/MAINT	SIRIUS COMPUTER SOLUTIONS	VMWARE VSPHERE, PRODUCTION SUPPORT	11,788.79	
100-100-54310	BUILDING MAINTENANCE	JACKSON SERVICES INC	MATS	54.81	
100-100-54380	MAINTENANCE AGREEMENTS	MIDWEST ALARM SERVICES	FIRE ALARM MONITORING	540.00	
100-100-55900	MISCELLANEOUS	PLATE COUNTY REGISTER OF	RESOLUTION R23-88, ORDINANCE 23-11	110.00	
100-100-56010	SUPPLIES	ACE HARDWARE & GARDEN CNT	BATTERIES	16.99	
100-100-56010	SUPPLIES	BOUND TREE MEDICAL LLC	FLUID SOLIDIFIER, BIOHAZARD BAG, BANDAG	43.05	
100-100-56010	SUPPLIES	EAKES OFFICE SOLUTIONS	NAPKINS, PLATES, TOWELS	371.11	
100-100-56010	SUPPLIES	MENARDS	POWER TOOL ADAPTER, 1X4-3' BOARD	8.41	
100-100-56020	OFFICE SUPPLIES	EAKES OFFICE SOLUTIONS	RETURN - REEL, CARD W/CLIP	(255.20)	
100-100-56030	CLEANING SUPPLIES/SERVICE	SERVICEMASTER BY SHEVLIN	JANITORIAL SERVICES	3,991.00	
100-100-56040	POSTAGE AND FREIGHT	QUADIENT LEASING USA, INC.	QUARTERLY MACHINE LEASE PAYMENT	642.63	
100-100-56240	TELEPHONE	GREAT PLAINS COMMUNICATION	PHONE/INTERNET CHARGES 8/16-9/15	145.59	
100-100-57200-20003	CAPITAL-LAND & BUILDINGS	JEO CONSULTING GROUP INC	COLUMBUS FLOOD MITIGATION & RESILIENCY	16,007.00	
100-100-57200-21092	CAPITAL-LAND & BUILDINGS	AOI CORPORATION	CREDENZA	2,362.58	
100-100-57200-21092	CAPITAL-LAND & BUILDINGS	B2 ENVIRONMENTAL INC	ASBESTOS ABATEMENT & HAZARDOUS MATERIAL	94,100.00	
100-100-57510-19009	CAPITAL-EQUIPMENT	SIRIUS COMPUTER SOLUTIONS	WI-FI CITY PARKS - FRANKFORT SQ, STADIU	41,178.14	
Total For Dept 100 GENERAL ADMINISTRATION				206,934.90	
Dept 102 COLUMBUS AREA TRANSIT					
100-102-56030	CLEANING SUPPLIES/SERVICE	JACKSON SERVICES INC	MAT	25.03	
100-102-56240	TELEPHONE	GREAT PLAINS COMMUNICATION	PHONE/INTERNET CHARGES 8/16-9/15	14.67	
Total For Dept 102 COLUMBUS AREA TRANSIT				39.70	
Dept 103 COLUMBUS SENIOR CENTER					
100-103-56010-III-C	SUPPLIES	SUPER SAVER	BLEACH, GROCERIES	14.52	
100-103-56240	TELEPHONE	GREAT PLAINS COMMUNICATION	PHONE/INTERNET CHARGES 8/16-9/15	36.68	
100-103-56300-III-C	FOOD COSTS	SUPER SAVER	BLEACH, GROCERIES	61.09	
100-103-57200-22004	CAPITAL-LAND & BUILDINGS	B-D CONSTRUCTION INC	SENIOR CENTER ENTRY RENO	24,404.40	
Total For Dept 103 COLUMBUS SENIOR CENTER				24,516.69	
Dept 104 CITY ADMINISTRATOR					
100-104-52700	TRAINING AND TUITION	VAN IPEREN JEAN	EXPENSES 2023 DOWNTOWN CONFERENCE SIOUX	548.11	
Total For Dept 104 CITY ADMINISTRATOR				548.11	
Dept 105 FINANCE					
100-105-56240	TELEPHONE	GREAT PLAINS COMMUNICATION	PHONE/INTERNET CHARGES 8/16-9/15	36.68	
Total For Dept 105 FINANCE				36.68	
Dept 106 CITY CLERK					
100-106-56240	TELEPHONE	GREAT PLAINS COMMUNICATION	PHONE/INTERNET CHARGES 8/16-9/15	29.34	
Total For Dept 106 CITY CLERK				29.34	
Dept 108 HUMAN RESOURCES					
100-108-56240	TELEPHONE	GREAT PLAINS COMMUNICATION	PHONE/INTERNET CHARGES 8/16-9/15	7.34	
Total For Dept 108 HUMAN RESOURCES				7.34	
Dept 110 POLICE					
100-110-52700	TRAINING AND TUITION	JOHN E. REID & ASSOCIATES	KYLE BLUNK-4 DAY THE REID TECHNIQUE OF	630.00	
100-110-52700	TRAINING AND TUITION	KIESLER POLICE SUPPLY	4 - GLOCK 45T 9MM TRAINING PISTOLS	1,816.00	

UNJOURNALIZED
 BOTH OPEN AND PAID

GL Number	Invoice Line Desc	Vendor	Invoice Description	Amount	Check #
Fund 100 GENERAL FUND					
Dept 110 POLICE					
100-110-52700	TRAINING AND TUITION	NEBRASKA LAW ENFORCEMENT	FEES - BALESTEN & FRENCH	284.00	
100-110-52700	TRAINING AND TUITION	SAYLER SCREENPRINTING	NLECT UNIFORMS - BALESTERI	254.00	
100-110-52700	TRAINING AND TUITION	STREET COP TRAINING	NEBRASKA CASE LAW THAT ALL COPS NEED TC	199.00	
100-110-52710	EMPLOYEE RECRUITMENT/RETENTION	MAILBOX	NEBRASKA LAW ENFORCEMENT CENTER	13.54	
100-110-52800	UNIFORMS	GALLS LLC	FLASHLIGHTS, BELT KEEPERS, CHAIN HANDCU	575.25	
100-110-52810	UNIFORMS-QUARTERMASTER	911 CUSTOM LLC	BLACKINTON FLEX BADGE - MCCLOUD QM	37.00	
100-110-52810	UNIFORMS-QUARTERMASTER	GALLS LLC	CARGO PANTS - HEESACKER QM	315.98	
100-110-52810	UNIFORMS-QUARTERMASTER	GUNSLINGERS LLC	OWB HOLSTER - UHL QM	769.99	
100-110-54310	BUILDING MAINTENANCE	M & O DOOR PRODUCTS	STAMP KEYS	15.64	
100-110-54310	BUILDING MAINTENANCE	NOSWETT FENCING INC	ADJUST GATE - IMPOUND YARD	175.00	
100-110-54320	EQUIPMENT MAINTENANCE	EAKES OFFICE SOLUTIONS	COPIER CONTRACT	164.41	
100-110-54320	EQUIPMENT MAINTENANCE	INTOXIMETERS INC	REPAIR HANDHELD	312.90	
100-110-54330	VEHICLE MAINTENANCE	ERNST AUTO CENTER	REPLACE FRONT BRAKE PADS & ROTOR VIN #5	688.39	
100-110-54380	MAINTENANCE AGREEMENTS	DAS STATE ACCOUNTING	MONTHLY NETWORK CHARGES	256.00	
100-110-55200	INSURANCE	LARM (LEAGUE ASSOCIATION C	ENDORSEMENT #25	(177.75)	
100-110-56030	CLEANING SUPPLIES/SERVICE	SERVICEMASTER BY SHEVLIN	JANITORIAL SERVICE	2,413.00	
100-110-56165	K9 PROGRAM	BOMGAARS	DOG FOOD	99.98	
100-110-56240	TELEPHONE	GREAT PLAINS COMMUNICATION	PHONE/INTERNET CHARGES 8/16-9/15	414.04	
Total For Dept 110 POLICE				9,256.37	
Dept 120 FIRE					
100-120-52710	EMPLOYEE RECRUITMENT/RETENTION	MAILBOX	STANARD & ASSOCIATES	12.52	
100-120-52710	EMPLOYEE RECRUITMENT/RETENTION	OCCUPATIONAL HEALTH SERV	COLLECTION & TESTING	67.00	
100-120-52800	UNIFORMS	GALLS LLC	REPLACEMENT PANTS	443.86	
100-120-54310	BUILDING MAINTENANCE	MIDWEST ALARM SERVICES	FIRE ALARM MONITORING- 424 8TH ST	420.00	
100-120-54310	BUILDING MAINTENANCE	PRESTOX	PEST CONTROL - 4630 HOWARD BLVD	31.12	
100-120-56010	SUPPLIES	MENARDS	50:1 FUEL PREMIX, 10CT CONTRACTOR BAGS	64.96	
100-120-56010	SUPPLIES	REARDON LAWN & GARDEN INC	AIR FILTER	5.99	
100-120-56020	OFFICE SUPPLIES	HOMETOWN LEASING	COPIER LEASE PAYMENT	87.50	
100-120-56030	CLEANING SUPPLIES/SERVICE	JACKSON SERVICES INC	MATS, MOPS, POLISH TOWEL, WINDSHIELD WI	66.92	
100-120-56190-20022	PERSONAL PROTECTIVE SUPP	MUNICIPAL EMERGENCY SERVIC	DEX TURNOUT COATS & PANTS	20,730.00	
100-120-56240	TELEPHONE	GREAT PLAINS COMMUNICATION	PHONE/INTERNET CHARGES 8/16-9/15	121.04	
100-120-57300	CAPITAL-NEW CONSTRUCTION	FRONTIER COOPERATIVE COMP	CORN FOR TRAINING BIN	4,999.97	
Total For Dept 120 FIRE				27,050.88	
Dept 121 RESCUE					
100-121-52800	UNIFORMS	GALLS LLC	REPLACEMENT PANTS	443.86	
100-121-54310	BUILDING MAINTENANCE	PRESTOX	PEST CONTROL - 4630 HOWARD BLVD	31.12	
100-121-54330	VEHICLE MAINTENANCE	ADVANCE AUTO PARTS	20 QT DRAIN PAN	359.13	
100-121-56010	SUPPLIES	BOUND TREE MEDICAL LLC	TOGGLES FOR ALUMINUM D & JUMBO D CYLINI	232.83	
100-121-56010	SUPPLIES	TOOLEY DRUG	CONTOUR NEXT	190.32	
100-121-56020	OFFICE SUPPLIES	HOMETOWN LEASING	COPIER LEASE PAYMENT	87.50	
100-121-56030	CLEANING SUPPLIES/SERVICE	JACKSON SERVICES INC	MATS, MOPS, POLISH TOWEL, WINDSHIELD WI	66.92	
100-121-56030	CLEANING SUPPLIES/SERVICE	STERICYCLE INC	MEDICAL WASTE SERVICES	348.96	
100-121-56190	PERSONAL PROTECTIVE SUPP	BOUND TREE MEDICAL LLC	NITRILE GLOVES	572.29	
100-121-56240	TELEPHONE	GREAT PLAINS COMMUNICATION	PHONE/INTERNET CHARGES 8/16-9/15	121.04	
Total For Dept 121 RESCUE				2,453.97	
Dept 130 LIBRARY					
100-130-52710	EMPLOYEE RECRUITMENT/RETENTION	OCCUPATIONAL HEALTH SERV	COLLECTION & TESTING	460.00	
100-130-53400-PCLAB	COMPUTER SUPPORT/MAINT	EAKES OFFICE SOLUTIONS	TONER	1,695.93	
100-130-53400-STAFF	COMPUTER SUPPORT/MAINT	EAKES OFFICE SOLUTIONS	TONER	60.99	
100-130-55400	ADVERTISING AND PROMOTION	BEST VERSION MEDIA, LLC	AD MANAGEMENT FEE	304.00	

UNJOURNALIZED
 BOTH OPEN AND PAID

GL Number	Invoice Line Desc	Vendor	Invoice Description	Amount	Check #
Fund 100 GENERAL FUND					
Dept 130 LIBRARY					
100-130-55400	ADVERTISING AND PROMOTION	LINCOLN JOURNAL STAR	WEEKLY AD	1,536.11	
100-130-56020	OFFICE SUPPLIES	EAKES OFFICE SOLUTIONS	RETURN - DESK CALENDAR	0.00	
100-130-56030	CLEANING SUPPLIES/SERVICE	SERVICEMASTER BY SHEVLIN	JANITORIAL SERVICES	7,278.00	
100-130-56240	TELEPHONE	GREAT PLAINS COMMUNICATION	PHONE/INTERNET CHARGES 8/16-9/15	102.70	
100-130-56400-YASCH	PROGRAMS	GODFATHER'S PIZZA	PIZZA	67.46	
100-130-56410-ADULT	BOOKS AND PUBLICATIONS	INGRAM LIBRARY SERVICES,	IMATERIALS	841.88	
100-130-56410-ADULT	BOOKS AND PUBLICATIONS	MIDWEST TAPE LLC	MATERIALS	308.11	
100-130-56410-YOUNG	BOOKS AND PUBLICATIONS	INGRAM LIBRARY SERVICES,	IMATERIALS	241.57	
100-130-57200-20030	CAPITAL-LAND & BUILDINGS	AOI CORPORATION	CREDENZA	5,020.46	
100-130-57200-20030	CAPITAL-LAND & BUILDINGS	EAKES OFFICE SOLUTIONS	COPIER	6,801.45	
100-130-57200-20030	CAPITAL-LAND & BUILDINGS	LIBRARY FURNITURE INTERNA	50% DEPOSIT	4,200.00	
100-130-57200-20030	CAPITAL-LAND & BUILDINGS	SCHOOL OUTFITTERS LLC	2 - BOOK RETURN DROP CARTS	1,904.52	
Total For Dept 130 LIBRARY				30,823.18	
Dept 140 CEMETERY					
100-140-54320	EQUIPMENT MAINTENANCE	BOMGAARS	LUBRICANT	61.31	
100-140-56240	TELEPHONE	GREAT PLAINS COMMUNICATION	PHONE/INTERNET CHARGES 8/16-9/15	7.34	
Total For Dept 140 CEMETERY				68.65	
Dept 145 COMMUNITY DEVELOPMENT					
100-145-54320	EQUIPMENT MAINTENANCE	REARDON LAWN & GARDEN INC	BRUSHKNIFE, COLLAR NUT, RIDER PLATE	56.98	
100-145-54330	VEHICLE MAINTENANCE	COLUMBUS TIRE & SERVICE	TIRE	119.54	
100-145-56020	OFFICE SUPPLIES	EAKES OFFICE SOLUTIONS	ROTARY CARD FILE	7.87	
100-145-56240	TELEPHONE	GREAT PLAINS COMMUNICATION	PHONE/INTERNET CHARGES 8/16-9/15	36.68	
Total For Dept 145 COMMUNITY DEVELOPMENT				221.07	
Dept 150 PARKS					
100-150-52800	UNIFORMS	JACKSON SERVICES INC	UNIFORMS	52.70	
100-150-54320	EQUIPMENT MAINTENANCE	ACE HARDWARE & GARDEN CNT	FLAP DISC, BLADE FUSES	64.35	
100-150-54320	EQUIPMENT MAINTENANCE	ARNOLD MOTOR SUPPLY	HP V-BELT	86.34	
100-150-54320	EQUIPMENT MAINTENANCE	BOMGAARS	FLY TRAP, FLY RIBBON	35.01	
100-150-54320	EQUIPMENT MAINTENANCE	COMMONWEALTH ELECTRIC COME	REPAIR SCOREBOARD	440.00	
100-150-54320	EQUIPMENT MAINTENANCE	MUELLER SPRINKLERS	72" EXTREME BLADES, BUSHING	56.10	
100-150-54320	EQUIPMENT MAINTENANCE	TIRE OUTLET INC	REPAIR	10.00	
100-150-54320	EQUIPMENT MAINTENANCE	TURFWERKS	PROXIMITY , WLDMT COMP	456.53	
100-150-54330	VEHICLE MAINTENANCE	ARNOLD MOTOR SUPPLY	6 - OIL SEALS	56.88	
100-150-56010	SUPPLIES	ACE HARDWARE & GARDEN CNT	BATTERIES, ELEC TAPE, FUSES	164.39	
100-150-56010	SUPPLIES	KOCH EXCAVATING CO INC	BLACK MULCH	440.00	
100-150-56010	SUPPLIES	MID-AMERICAN RESEARCH	BOWL CLEANER	150.00	
100-150-56010	SUPPLIES	MUELLER SPRINKLERS	12 - HUNTER I 25 ADV	1,067.76	
100-150-56010	SUPPLIES	SCHIEFFER SIGNS INC	LOITERING PROHIBITED SIGNS	154.00	
100-150-56080	PLANTS SOD SEED FLOWERS	ZIMCO SUPPLY CO	SOD GROWER II	340.00	
100-150-56240	TELEPHONE	GREAT PLAINS COMMUNICATION	PHONE/INTERNET CHARGES 8/16-9/15	29.34	
100-150-56400	PROGRAMS	CAPITAL ONE - WALMART	KA BURST, GRENADINE, SALT, PTZL RODS, I	93.02	
100-150-56400	PROGRAMS	CLOSSON ROD	UMP: MEN'S LEAGUE TOURNAMENT 8/8, 8/9	180.00	
100-150-56400	PROGRAMS	COLUMBUS MARINERS	BASEBALL MOUND RENTAL	500.00	
100-150-56400	PROGRAMS	GUTIERREZ JUAN	UMP: MEN'S LEAGUE TOURNAMENT 8/8, 8/9	180.00	
100-150-56400	PROGRAMS	VOICE HOUSE	ADDITIONAL EXPENSES FOR ANDY WILLIAM AI	300.00	
100-150-57200-21067	CAPITAL-LAND & BUILDINGS	SAND CREEK CONSTRUCTION CC	CENTENNIAL PARK SPLASH PAD	16,600.00	
100-150-57200-23016	CAPITAL-LAND & BUILDINGS	NEMAHA LANDSCAPE CONSTRUCT	PAWNEE PARK TURF REPLACEMENT	57,900.00	
100-150-57300-23012	CAPITAL-NEW CONSTRUCTION	CONFLUENCE INC	23009 PAWNEE PARK/GERRARD PARK RENOVATI	36,956.09	
100-150-57300-23013	CAPITAL-NEW CONSTRUCTION	SAND CREEK CONSTRUCTION CC	GERRARD PARK TENNIS & PICKLEBALL COURT	20,246.18	

UNJOURNALIZED
 BOTH OPEN AND PAID

GL Number	Invoice Line Desc	Vendor	Invoice Description	Amount	Check #
Fund 100 GENERAL FUND					
Dept 150 PARKS					
Total For Dept 150 PARKS				136,558.69	
Dept 151 PAWNEE PLUNGE WATER PARK					
100-151-52700	TRAINING AND TUITION	AMERICAN RED CROSS	LIFEGUARDING & WATERPARK SKILLS, CPR/AE	187.00	
100-151-54320	EQUIPMENT MAINTENANCE	MENARDS	FIP ADAPTER	9.18	
100-151-56010	SUPPLIES	CAPITAL ONE - WALMART	AIRHEADS, DAWN, STING-KILL, DIG TIMER	27.04	
100-151-56030	CLEANING SUPPLIES/SERVICE	MENARDS	10CT CONTRACTOR BAGS	23.56	
100-151-56090	SMALL TOOLS	ACE HARDWARE & GARDEN CNT	TORX BIT SOCKET SET	54.98	
100-151-56240	TELEPHONE	GREAT PLAINS COMMUNICATION	PHONE/INTERNET CHARGES 8/16-9/15	14.67	
100-151-56300	FOOD COSTS	CAPITAL ONE - WALMART	AIRHEADS, DAWN, STING-KILL, DIG TIMER	392.22	
100-151-56400	PROGRAMS	PLATTE VALLEY HUMANE SOCIETY	50/50 PROCEEDS FROM THE PUPPY PLUNGE	400.00	
Total For Dept 151 PAWNEE PLUNGE WATER PARK				1,108.65	
Dept 152 AQUATIC CENTER POOL					
100-152-56240	TELEPHONE	GREAT PLAINS COMMUNICATION	PHONE/INTERNET CHARGES 8/16-9/15	14.67	
Total For Dept 152 AQUATIC CENTER POOL				14.67	
Dept 155 VAN BERG GOLF COURSE					
100-155-54310	BUILDING MAINTENANCE	ACE HARDWARE & GARDEN CNT	PADLOCK	15.99	
100-155-54320	EQUIPMENT MAINTENANCE	NAPA AUTO PARTS OF COLUMBUS	BATTERY	41.23	
100-155-54490	IRRIGATION MAINTENANCE	KELLY SUPPLY COMPANY	1-1/4 PVC 40 90 ELL, PVC 40 BUSH	67.33	
100-155-54520	EQUIPMENT RENTAL/PURCHASE	MR GOLF CAR INC	RENTAL/TOURNAMENT CARS 8/12/23	840.00	
100-155-55200	INSURANCE	LARM (LEAGUE ASSOCIATION OF)	LIQUOR LIABILITY POLICY	1,454.00	
100-155-56060	CHEMICALS	D & K PRODUCTS	HERBICIDE & FUNGICIDE	3,232.00	
100-155-56070	FERTILIZER	D & K PRODUCTS	80 - EC 24-5-10 50% EPEC 90, 3% FE 50LE	1,960.00	
100-155-56070	FERTILIZER	ZIMCO SUPPLY CO	REWARD 2.5 GAL AQUATIC HERBICIDE	240.00	
100-155-56110	PRO-SHOP SUPPLIES	HADLEY-BRAITHWAIT COMPANY	CASE 20J16	53.95	
100-155-56110	PRO-SHOP SUPPLIES	VACUUM CENTER	BELTS	17.95	
100-155-56240	TELEPHONE	GREAT PLAINS COMMUNICATION	PHONE/INTERNET CHARGES 8/16-9/15	22.01	
Total For Dept 155 VAN BERG GOLF COURSE				7,944.46	
Dept 156 QUAIL RUN GOLF COURSE					
100-156-54320	EQUIPMENT MAINTENANCE	ARNOLD MOTOR SUPPLY	AIR FILTER	87.27	
100-156-54320	EQUIPMENT MAINTENANCE	MIDWEST TURF & IRRIGATION	STARTER	454.78	
100-156-54350	GOLF CART/COURSE MAINT	ARNOLD MOTOR SUPPLY	SERRATED WHEEL STUD	11.84	
100-156-54520	EQUIPMENT RENTAL/PURCHASE	MR GOLF CAR INC	RENTAL/TOURNAMENT CARS 8/14/23	6,060.00	
100-156-55400	ADVERTISING AND PROMOTION	ADDEPT MEDIA LLC	HUMPHREY DEMOCRAT	100.00	
100-156-56010	SUPPLIES	ACE HARDWARE & GARDEN CNT	FLEX TAPE	14.99	
100-156-56010	SUPPLIES	BOMGAARS	BULK BOLTS	13.21	
100-156-56010	SUPPLIES	JACKSON SERVICES INC	UNIFORMS	26.71	
100-156-56110	PRO-SHOP SUPPLIES	HADLEY-BRAITHWAIT COMPANY	CENTER PULL TOWELS	117.90	
100-156-56240	TELEPHONE	GREAT PLAINS COMMUNICATION	PHONE/INTERNET CHARGES 8/16-9/15	58.69	
Total For Dept 156 QUAIL RUN GOLF COURSE				6,945.39	
Total For Fund 100 GENERAL FUND				454,558.74	
Fund 200 STREETS/ENGINEERING					
Dept 200 STREETS					
200-200-52800	UNIFORMS	JACKSON SERVICES INC	UNIFORMS	429.32	
200-200-53200	PROFESSIONAL SERVICES	MOMS & MOPS	CLEANING CENTRAL MAINTENANCE	106.66	
200-200-54310	BUILDING MAINTENANCE	MIDWEST PETROLEUM EQUIPMENT	CARD READER INOPERABLE	394.75	
200-200-54310	BUILDING MAINTENANCE	POWER TECH LLC	GENERATOR CALL OUT - CENTRAL MAINTENANC	188.22	
200-200-54320	EQUIPMENT MAINTENANCE	AKRS EQUIPMENT	TOOLBOX	59.83	
200-200-54320	EQUIPMENT MAINTENANCE	BOMGAARS	HOSE MENDER, HOSE CLAMP	23.05	

UNJOURNALIZED
 BOTH OPEN AND PAID

GL Number	Invoice Line Desc	Vendor	Invoice Description	Amount	Check #
Fund 200 STREETS/ENGINEERING					
Dept 200 STREETS					
200-200-54320	EQUIPMENT MAINTENANCE	CSH LLC	TEST PUMP	250.00	
200-200-54320	EQUIPMENT MAINTENANCE	MID-IOWA SOLID WASTE	4-SEGMENT GUTTER BROOM	506.40	
200-200-54320	EQUIPMENT MAINTENANCE	REARDON LAWN & GARDEN INC	ROPE GUIDE	29.00	
200-200-54320	EQUIPMENT MAINTENANCE	RIVER VALLEY TIRE SERVICE	2 - 19.5L 24 FIRESTONE ALL TRACTION	1,520.00	
200-200-54330	VEHICLE MAINTENANCE	ADVANCE AUTO PARTS	5.4 LONG BLOCK	4,175.00	
200-200-54330	VEHICLE MAINTENANCE	GAVER TIRE & AUTO CENTER	14 - GENERAL GRABBER TIRES	904.83	
200-200-54450	STREET MAINTENANCE	GEHRING CONSTRUCTION &	3281 51ST AVE	3,412.50	
200-200-54450	STREET MAINTENANCE	GERHOLD CONCRETE COMPANY	457 10TH AVE	168.62	
200-200-56010	SUPPLIES	ACE HARDWARE & GARDEN CNT	NUTS, BOLTS, SCREWS	51.02	
200-200-56010	SUPPLIES	BOMGAARS	TAPE MEASURE, FASTENING SET, SHOP TOWEL	98.95	
200-200-56010	SUPPLIES	GEHRING CONSTRUCTION &	SL-1 CAULKING 30OZ TUBE	4,257.28	
200-200-56010	SUPPLIES	GRIMES ASPHALT & PAVING CC	COLD MIX	2,320.20	
200-200-56010	SUPPLIES	MIDWEST SERVICE & SALES CC	DOUBLE BEVEL CURVE HEAT TREATED CARBIDE	4,615.12	
200-200-56010	SUPPLIES	SHERWIN-WILLIAMS CO	GLASS BEADS	1,306.00	
200-200-56010	SUPPLIES	SMITH FERTILIZER GRAIN	BEET 55	7,358.11	
200-200-56020	OFFICE SUPPLIES	EAKES OFFICE SOLUTIONS	CALENDARS	96.72	
200-200-56040	POSTAGE AND FREIGHT	MAILBOX	GENERAL TRAFFIC CONTROLS	41.68	
200-200-56090	SMALL TOOLS	ACE HARDWARE & GARDEN CNT	STIHL MS 194, 14" & 18" CHAIN	552.97	
200-200-56090	SMALL TOOLS	BOMGAARS	SPOTLIGHT, BATTERY, GLOVES	137.96	
200-200-56090	SMALL TOOLS	SUBSURFACE SOLUTIONS	LIVE CABLE CONNECTOR	600.33	
200-200-56120	TRAFFIC SIGNS	NEWMAN SIGNS INC.	SIGNS	433.38	
200-200-56190	PERSONAL PROTECTIVE SUPP	BOMGAARS	SPOTLIGHT, BATTERY, GLOVES	103.40	
200-200-56240	TELEPHONE	GREAT PLAINS COMMUNICATION	PHONE/INTERNET CHARGES 8/16-9/15	29.34	
200-200-57200-21077	CAPITAL-LAND & BUILDINGS	GENERAL TRAFFIC CONTROLS	128 - 13' POLE ASSY	21,000.00	
200-200-57200-21077	CAPITAL-LAND & BUILDINGS	NEWMAN SIGNS INC.	SIGNS	2,551.20	
200-200-57200-23025	CAPITAL-LAND & BUILDINGS	GEHRING CONSTRUCTION &	SID #189 48TH AVE FROM 23RD ST TO S OF	164,774.50	
200-200-57300-20070	CAPITAL-NEW CONSTRUCTION	GEHRING CONSTRUCTION &	12TH ST & 28TH AVE	49,541.00	
200-200-57300-20071	CAPITAL-NEW CONSTRUCTION	GEHRING CONSTRUCTION &	SID #189 48TH AVE FROM 23RD ST TO S OF	268,703.25	
Total For Dept 200 STREETS				540,740.59	
Dept 202 MECHANICS SHOP					
200-202-52800	UNIFORMS	JACKSON SERVICES INC	UNIFORMS	63.86	
200-202-56010	SUPPLIES	BOMGAARS	FITTINGS	9.98	
200-202-56010	SUPPLIES	ISLAND SUPPLY WELDING CO.	ZIP WHEEL	24.22	
200-202-56010	SUPPLIES	MOTION INDUSTRIES INC	NITRILE DISP GLOVES	65.12	
200-202-56010	SUPPLIES	O'REILLY AUTOMOTIVE INC	SEAM SEALER, MASKING TAPE	75.29	
200-202-56090	SMALL TOOLS	O'REILLY AUTOMOTIVE INC	TELE MIRROR	5.49	
200-202-56130	SUPPLIES FOR RESALE	ACE HARDWARE & GARDEN CNT	NUTS, BOLTS, SCREWS	39.53	
200-202-56130	SUPPLIES FOR RESALE	ADVANCE AUTO PARTS	OIL FILTER	51.94	
200-202-56130	SUPPLIES FOR RESALE	AKRS EQUIPMENT	FUEL PUMP	96.62	
200-202-56130	SUPPLIES FOR RESALE	ARNOLD MOTOR SUPPLY	4 - CLR/MKR LAMPS	57.86	
200-202-56130	SUPPLIES FOR RESALE	BOMGAARS	MANIFOLD REPAIR, ELBOW	54.94	
200-202-56130	SUPPLIES FOR RESALE	LAWSON PRODUCTS	MEGACRIMP FTG, NYLON CABLE TIES	214.94	
200-202-56130	SUPPLIES FOR RESALE	MENARDS	100 PC NUT & BOLT ASST	1.49	
200-202-56130	SUPPLIES FOR RESALE	O'REILLY AUTOMOTIVE INC	W/O GASKET	21.38	
200-202-56130	SUPPLIES FOR RESALE	SHANE'S REPAIR	DIESEL CARE, DIESEL FUEL CLEANER	225.81	
Total For Dept 202 MECHANICS SHOP				1,008.47	
Total For Fund 200 STREETS/ENGINEERING				541,749.06	
Fund 205 AIRPORT					
Dept 000					
205-000-10100	FUND CASH	BIG PALS LITTLE PALS	19-DTR-101 CDBG #30	6,380.19	

UNJOURNALIZED
 BOTH OPEN AND PAID

GL Number	Invoice Line Desc	Vendor	Invoice Description	Amount	Check #
Fund 205 AIRPORT					
Dept 000					
Total For Dept 000				6,380.19	
Dept 205 AIRPORT					
205-205-52700	TRAINING AND TUITION	NIEDBALSKI ROSS	MILEAGE - 4 STATE AIRPORT CONFERENCE KF	360.25	
205-205-56010	SUPPLIES	ACE HARDWARE & GARDEN CNT	KEY SCHLAGE	5.98	
205-205-56010	SUPPLIES	MIDWEST TURF & IRRIGATION RELAY		119.79	
205-205-56010	SUPPLIES	TIRE OUTLET INC	TUBE	7.50	
205-205-56240	TELEPHONE	GREAT PLAINS COMMUNICATION	PHONE/INTERNET CHARGES 8/16-9/15	22.01	
205-205-57200-23030	CAPITAL-LAND & BUILDINGS	KIRKHAM MICHAEL & ASSOCIAT	CONSTRUCT 8-PLACE T-HANGER	14,813.34	
Total For Dept 205 AIRPORT				15,328.87	
Total For Fund 205 AIRPORT				21,709.06	
Fund 220 COMMUNICATIONS - E911					
Dept 220 E911					
220-220-43915	COUNTY REIMBURSEMENTS	PLATTE COUNTY	REFUND FOR OVER PAYMENT - E911 COUNTY	172,219.92	
220-220-52710	EMPLOYEE RECRUITMENT/RETENTION	OCCUPATIONAL HEALTH SERV	COLLECTION & TESTING	67.00	
220-220-54310	BUILDING MAINTENANCE	K-T HEATING & AIR CONDITIC	COMMERCIAL SERVICE CALL	393.75	
220-220-54320	EQUIPMENT MAINTENANCE	MOTOROLA SOLUTIONS INC.	5 YEAR MAINTENANCE & SUPPORT CONTRACT	54,947.48	
220-220-54320	EQUIPMENT MAINTENANCE	POWER TECH LLC	GENERATOR SERVICE AGREEMENT	970.00	
220-220-54380	MAINTENANCE AGREEMENTS	GEOCOMM INC	GIS MAP DATA MAINTENANCE, MSAG & ALI DF	17,499.00	
220-220-56010	SUPPLIES	CAPITAL ONE - WALMART	DUM DUMS, CANDY, VIVA, LYSOL, CANOPY	118.46	
220-220-56240	TELEPHONE	GREAT PLAINS COMMUNICATION	PHONE/INTERNET CHARGES 8/16-9/15	7.34	
220-220-57510-21084	CAPITAL-EQUIPMENT	INTERSTATE ALL BATTERY CEM	BATTERY	316.39	
220-220-57510-23032	CAPITAL-EQUIPMENT	APCO INTERNATIONAL	APCO INTELICOMM SOFTWARE, EMD PRODUCTI	17,717.22	
Total For Dept 220 E911				264,256.56	
Total For Fund 220 COMMUNICATIONS - E911				264,256.56	
Fund 225 COMMUNICATIONS-EC-911 EQUIPMENT SHARING					
Dept 225 EC-911 EQUIPMENT SHARING					
225-225-56240	TELEPHONE	DAS STATE ACCOUNTING	MONTHLY NETWORK CHARGES	1,215.99	
Total For Dept 225 EC-911 EQUIPMENT SHARING				1,215.99	
Total For Fund 225 COMMUNICATIONS-EC-911 EQUIPMENT SHAF				1,215.99	
Fund 240 HOUSING REHAB & LOANS					
Dept 240 HOUSING REHAB & LOANS					
240-240-56780	HOUSING LOANS & ADMIN	NORTHEAST NEBRASKA ECONOMIC	CDBG REHAB REUSE JULY 2023 ADMIN SERVIC	106.25	
Total For Dept 240 HOUSING REHAB & LOANS				106.25	
Dept 243 CDBG REVOLVING REHAB LOAN					
240-243-56780	HOUSING LOANS & ADMIN	LEVEL ONE PROPERTIES	19-DTR-101CDBG #30	3,283.82	
240-243-56780	HOUSING LOANS & ADMIN	NORTHEAST NEBRASKA ECONOMIC	DHA TRUST REUSE JULY 2023 ADMIN SERVICE	21.25	
Total For Dept 243 CDBG REVOLVING REHAB LOAN				3,305.07	
Dept 244 CDBG DPA LOANS (NENEDD)					
240-244-56780	HOUSING LOANS & ADMIN	NORTHEAST NEBRASKA ECONOMIC	CDBG DHA REUSE JULY 2023 ADMIN SERVICES	203.50	
Total For Dept 244 CDBG DPA LOANS (NENEDD)				203.50	
Total For Fund 240 HOUSING REHAB & LOANS				3,614.82	
Fund 500 UTILITY SERVICE					
Dept 000					

UNJOURNALIZED
BOTH OPEN AND PAID

GL Number	Invoice Line Desc	Vendor	Invoice Description	Amount	Check #
Fund 500 UTILITY SERVICE					
Dept 000					
500-000-20100	SOM-2	BAKER PAUL	UB refund for account: 400-80470-02	597.89	
				597.89	
Total For Dept 000					
Dept 500 WASTEWATER COLLECTION					
500-500-52800	UNIFORMS	JACKSON SERVICES INC	UNIFORMS	270.42	
500-500-53200	PROFESSIONAL SERVICES	MOMS & MOPS	CLEANING CENTRAL MAINTENANCE	106.67	
500-500-54310	BUILDING MAINTENANCE	ACE HARDWARE & GARDEN CNT	GATORLINE	13.99	
500-500-54310	BUILDING MAINTENANCE	POWER TECH LLC	GENERATOR CALL OUT - CENTRAL MAINTENANC	188.22	
500-500-54320	EQUIPMENT MAINTENANCE	BOMGAARS	SPRAY PAINT, PRIMER, BRUSH	25.12	
500-500-54320	EQUIPMENT MAINTENANCE	GAVER TIRE & AUTO CENTER I	CARLISLE INDUSTRIAL DEEP TRACTION	75.36	
500-500-54320	EQUIPMENT MAINTENANCE	LAKEVIEW SMALL ENGINE INC	BELT - PUMP DRI	75.15	
500-500-54320	EQUIPMENT MAINTENANCE	MENARDS	WD-40, ROUND BASE MAGNET	17.95	
500-500-54320	EQUIPMENT MAINTENANCE	MUNICIPAL PIPE TOOL CO LLC	CONTROLLER	303.84	
500-500-54320	EQUIPMENT MAINTENANCE	TRUCK CENTER COMPANIES	CAP-DEF TANK EXTENDED	28.94	
500-500-54320	EQUIPMENT MAINTENANCE	USA BLUE BOOK	4-1/2" INSULATED PROBES	772.34	
500-500-54390	SYSTEM MAINTENANCE	ACE HARDWARE & GARDEN CNT	NUTS, BOLTS, EXT FLAT WHITE PAINT	53.74	
500-500-54390	SYSTEM MAINTENANCE	KELLY SUPPLY COMPANY	GATES STEMS	67.04	
500-500-54390	SYSTEM MAINTENANCE	LINCOLN WINWATER WORKS	8 - FERNCO SEWER	695.38	
500-500-54390	SYSTEM MAINTENANCE	SCHUMACHER IRRIGATION INC	2 - PIPES 8" SOCKET W/LEVER	871.70	
500-500-54390	SYSTEM MAINTENANCE	USA BLUE BOOK	2" HONDA TRASH PUMP CAGE MOUNTED 163CC	1,484.71	
500-500-55900	MISCELLANEOUS	PETTY CASH	VEHICLE TITLE/REGISTRATION	8.00	
500-500-56040	POSTAGE AND FREIGHT	MAILBOX	BETH KRAMER	6.38	
500-500-56090	SMALL TOOLS	BOMGAARS	BATTERY, SPOTLIGHTS	165.83	
500-500-56240	TELEPHONE	GREAT PLAINS COMMUNICATION	PHONE/INTERNET CHARGES 8/16-9/15	33.57	
500-500-57300-20091	CAPITAL-NEW CONSTRUCTION	HDR ENGINEERING INC	LOST CREEK PARKWAY SEWER PROJECT - R21-	8,886.62	
500-500-57300-20091	CAPITAL-NEW CONSTRUCTION	MID-STATE ENGINEERING & TE	LOST CREEK PARKWAY SEWER & WATERMAIN	128.50	
500-500-57510-23038	CAPITAL-EQUIPMENT	HDR ENGINEERING INC	WATER & WASTEWATER USER RATE STUDY	1,377.86	
				15,657.33	
Total For Dept 500 WASTEWATER COLLECTION					
Dept 501 WASTEWATER TREATMENT FAC					
500-501-52800	UNIFORMS	JACKSON SERVICES INC	UNIFORMS	197.62	
500-501-54320	EQUIPMENT MAINTENANCE	ARNOLD MOTOR SUPPLY	BELT DRESSING & COND 60Z	5.19	
500-501-54320	EQUIPMENT MAINTENANCE	GRAINGER	MOTOR 1/8 HP	168.63	
500-501-54320	EQUIPMENT MAINTENANCE	MENARDS	BAR & CHAIN LUBE, REDUC BUSHING, LOCKNU	12.95	
500-501-54320	EQUIPMENT MAINTENANCE	MOTION INDUSTRIES INC	ELEMENT	922.64	
500-501-54320	EQUIPMENT MAINTENANCE	O'REILLY AUTOMOTIVE INC	AIR FILTER	35.90	
500-501-54330	VEHICLE MAINTENANCE	TIRE OUTLET INC	REPAIR	35.00	
500-501-56010	SUPPLIES	BOMGAARS	GRINDER, PRESSURE CAP, ROTARY FILE	53.36	
500-501-56010	SUPPLIES	CAPITAL ONE - WALMART	FACE TISSUE, DAWN, PENS, GLUE TRAY, SPC	161.94	
500-501-56030	CLEANING SUPPLIES/SERVICE	JACKSON SERVICES INC	MAT	26.71	
500-501-56060	CHEMICALS	MID-AMERICAN RESEARCH	SEWER SOLVNET, VEG-A-KILL, WIPE OUT 25#	2,856.50	
500-501-56240	TELEPHONE	GREAT PLAINS COMMUNICATION	PHONE/INTERNET CHARGES 8/16-9/15	36.68	
				4,513.12	
Total For Dept 501 WASTEWATER TREATMENT FAC					
				20,768.34	
Total For Fund 500 UTILITY SERVICE					
Fund 520 WATER					
Dept 000					
520-000-20100	WAM-41	DELOZIER EUGENE	UB refund for account: 100-15880-01	323.70	
				323.70	
Total For Dept 000					
Dept 520 WATER					
520-520-52700	TRAINING AND TUITION	ABSALON ROBERT	GRAND ISLAND GRADE 2 CLASS - REIMBURSE	95.78	

UNJOURNALIZED
 BOTH OPEN AND PAID

GL Number	Invoice Line Desc	Vendor	Invoice Description	Amount	Check #
Fund 520 WATER					
Dept 520 WATER					
520-520-52800	UNIFORMS	JACKSON SERVICES INC	UNIFORMS	147.45	
520-520-53200	PROFESSIONAL SERVICES	MOMS & MOPS	CLEANING CENTRAL MAINTENANCE	106.67	
520-520-54310	BUILDING MAINTENANCE	ACE HARDWARE & GARDEN CNT	PRUNER	154.00	
520-520-54310	BUILDING MAINTENANCE	POWER TECH LLC	GENERATOR CALL OUT - SOUTH PLANT	1,694.40	
520-520-54320	EQUIPMENT MAINTENANCE	ACE HARDWARE & GARDEN CNT	PROPANE	105.90	
520-520-54320	EQUIPMENT MAINTENANCE	BOMGAARS	SPRAY PAINT, PRIMER, BRUSH	25.13	
520-520-54320	EQUIPMENT MAINTENANCE	GAVER TIRE & AUTO CENTER I	CARLISLE INDUSTRIAL DEEP TRACTION	75.36	
520-520-54320	EQUIPMENT MAINTENANCE	KELLY SUPPLY COMPANY	1/2 INSERT 90 ELL, 1/2 PVC SCH 80 COUP	29.04	
520-520-54320	EQUIPMENT MAINTENANCE	LAKEVIEW SMALL ENGINE INC	BELT - PUMP DRI	75.16	
520-520-54320	EQUIPMENT MAINTENANCE	TRUCK CENTER COMPANIES	CAP-DEF TANK EXTENDED	28.93	
520-520-54320	EQUIPMENT MAINTENANCE	USA BLUE BOOK	Y-STRAINER; SOCKET	253.47	
520-520-54390	SYSTEM MAINTENANCE	ACE HARDWARE & GARDEN CNT	EXT FLAT WHITE	42.79	
520-520-54390	SYSTEM MAINTENANCE	GEHRING CONSTRUCTION &	18TH AVE & 6TH ST	789.41	
520-520-54390	SYSTEM MAINTENANCE	HOA SOLUTIONS INC	PROGRAMMING - ADDED PID BLOCK FOR HIGH	2,238.00	
520-520-54390	SYSTEM MAINTENANCE	KELLY SUPPLY COMPANY	1/2 PVC FEMALE ADAPTER	48.46	
520-520-54390	SYSTEM MAINTENANCE	LINCOLN WINWATER WORKS	8 - MACRO REPLACEMENT	5,949.87	
520-520-55640	COMPLIANCE TESTING	NEBRASKA PUBLIC HEALTH	WATER TESTING	2,235.00	
520-520-55900	MISCELLANEOUS	PETTY CASH	VEHICLE TITLE/REGISTRATION	8.00	
520-520-56010	SUPPLIES	EAKES OFFICE SOLUTIONS	CENTER PULL TOWELS, ADHES NOTES	145.67	
520-520-56040	POSTAGE AND FREIGHT	MAILBOX	NEBRASKA PUBLIC HEALTH	101.10	
520-520-56060	CHEMICALS	HAWKINS INC	CHEMICALS	6,156.14	
520-520-56090	SMALL TOOLS	BOMGAARS	BATTERY, SPOTLIGHTS	165.84	
520-520-56240	TELEPHONE	GREAT PLAINS COMMUNICATION	PHONE/INTERNET CHARGES 8/16-9/15	55.58	
520-520-57200-22031	CAPITAL-LAND & BUILDINGS	HDR ENGINEERING INC	DESIGN & CONSTRUCTION LOST CREEK PKWY W	4,905.30	
520-520-57510-23042	CAPITAL-EQUIPMENT	HDR ENGINEERING INC	WATER SYSTEM HYDRAULIC MODEL & MASTER E	67,470.00	
		Total For Dept 520 WATER		93,102.45	
		Total For Fund 520 WATER		93,426.15	
Fund 560 STORMWATER UTILITY					
Dept 000					
560-000-20100	SUF-6	BAKER PAUL	UB refund for account: 400-80470-02	35.04	
		Total For Dept 000		35.04	
Dept 560 STORMWATER UTILITY					
560-560-53200	PROFESSIONAL SERVICES	JEO CONSULTING GROUP INC	COLUMBUS FLOODPLAIN ADMINISTRATION SUPE	6,073.75	
560-560-54330	VEHICLE MAINTENANCE	ERNST AUTO CENTER	OIL CHANGE, CABIN AIR FILTER VIN #4877	114.04	
		Total For Dept 560 STORMWATER UTILITY		6,187.79	
		Total For Fund 560 STORMWATER UTILITY		6,222.83	
Fund 570 SOLID WASTE DIVISION					
Dept 000					
570-000-20100	SWD-1	BAKER PAUL	UB refund for account: 400-80470-02	19.75	
		Total For Dept 000		19.75	
Dept 570 TRANSFER STATION					
570-570-52800	UNIFORMS	JACKSON SERVICES INC	UNIFORMS	274.08	
570-570-54320	EQUIPMENT MAINTENANCE	MENARDS	WHITE PEX TUBE, SAFETY VEST, INSECT SPF	6.08	
570-570-54320	EQUIPMENT MAINTENANCE	ROAD BUILDERS MACHINERY AN	KDPF EXCHANGE	5,849.85	
570-570-54330	VEHICLE MAINTENANCE	COLUMBUS TIRE & SERVICE	REPAIR TIRE	50.00	
570-570-54330	VEHICLE MAINTENANCE	MENARDS	RIVETS, FENDER WASHER, DAWN, DE-BUG, WI	38.46	
570-570-54330	VEHICLE MAINTENANCE	NAPA AUTO PARTS OF COLUMBU	CHUCK HD, GROMMET, LAMP	96.15	

UNJOURNALIZED
 BOTH OPEN AND PAID

GL Number	Invoice Line Desc	Vendor	Invoice Description	Amount	Check #
Fund 570 SOLID WASTE DIVISION					
Dept 570 TRANSFER STATION					
570-570-54330	VEHICLE MAINTENANCE	POMP'S TIRE SERVICE INC.	REPLACE RFO & RR DUALS ON TRAILER	754.88	
570-570-54330	VEHICLE MAINTENANCE	TRUCK CENTER COMPANIES	REC M/C LIGHT/REFLECTOR AMBER	4.68	
570-570-56010	SUPPLIES	MENARDS	RIVETS, FENDER WASHER, DAWN, DE-BUG, WI	48.26	
570-570-56020	OFFICE SUPPLIES	EAKES OFFICE SOLUTIONS	TONER	281.34	
570-570-56030	CLEANING SUPPLIES/SERVICE	JACKSON SERVICES INC	MATS, ROLLER TOWELS, UNIFORMS	34.16	
570-570-56190	PERSONAL PROTECTIVE SUPP	MENARDS	WHITE PEX TUBE, SAFETY VEST, INSECT SPF	43.94	
570-570-56240	TELEPHONE	GREAT PLAINS COMMUNICATION	PHONE/INTERNET CHARGES 8/16-9/15	22.01	
Total For Dept 570 TRANSFER STATION				<u>7,503.89</u>	
Total For Fund 570 SOLID WASTE DIVISION				<u><u>7,523.64</u></u>	

UNJOURNALIZED
BOTH OPEN AND PAID

GL Number	Invoice Line Desc	Vendor	Invoice Description	Amount	Check #
-----------	-------------------	--------	---------------------	--------	---------

Fund Totals:

Fund 100 GENERAL FUND	454,558.74
Fund 200 STREETS/ENGINEE	541,749.06
Fund 205 AIRPORT	21,709.06
Fund 220 COMMUNICATIONS	264,256.56
Fund 225 COMMUNICATIONS-	1,215.99
Fund 240 HOUSING REHAB	3,614.82
Fund 500 UTILITY SERVICE	20,768.34
Fund 520 WATER	93,426.15
Fund 560 STORMWATER UTIL	6,222.83
Fund 570 SOLID WASTE DIV	7,523.64
Total For All Funds:	<u>1,415,045.19</u>

5. APPROVAL OF MINUTES - Included in Consent Agenda

6. SPECIAL PRESENTATIONS - None

7. PUBLIC HEARINGS

7.A. Public hearing - One and Six Year Plan

The City of **Columbus**

MEMORANDUM

DATE: August 10, 2023
FROM: Richard J. Bogus, P.E., City Engineer
TO: Tara Vasicek, City Administrator
RE: Nebraska Board of Public Roads Classifications and Standards
2023-2024 Fiscal Year One and Six Year Road Plan

RECOMMENDATION:

I recommend approval of the 2023-2024 fiscal year One and Six Year Road Plan and related forms.

DISCUSSION:

The 2024 One Year Plan (Form 8) consists of the following. Refer to the One and Six Year Road Plan map and Form 7s for locations and details.

Total number of projects: 10
City projects: 7
Private development projects: 3
Projects completed: 7
Projects continued: 9

Total One Year Plan estimated cost: \$39.7 million
Public projects: \$38.9 million
Private projects: \$0.7 million

The 2024 Six Year Plan (Form 9) consists of the following. Refer to the One and Six Year Road Plan map and Form 7s for locations and details.

Total number of additional projects from the One Year Plan: 23
Total estimated additional project costs from the One Year Plan: \$27.4 million

The 2023 One & Six Year Road Plan was amended with one project (Form 10)

Maintenance defined projects are not included by rule in the One and Six Year Road Plans.

FISCAL IMPACT:

The City has included its portion of the costs in the 2022-2023 and/or 2023-2024 budgets

ALTERNATIVE:

Annual 1&6 Year Road Plan certification is required to obtain Highway-user revenue.

SIGNATURE:

By: Richard J. Bogus

Approved By: [Signature]

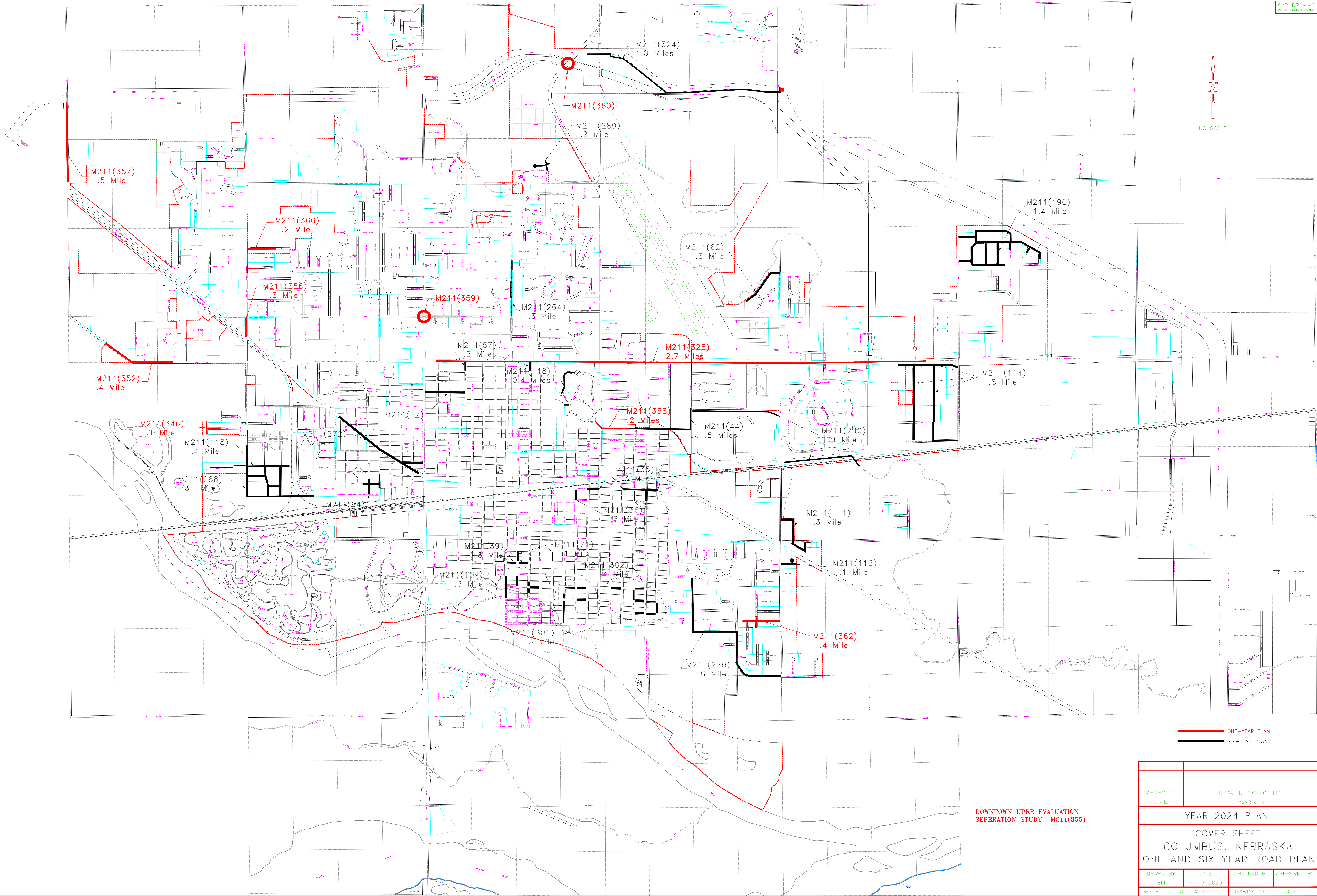
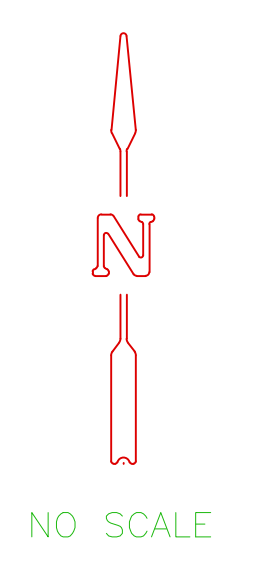

DOWNTOWN UPRR EVALUATION
SEPERATION STUDY M211(355)

7-7-2022		UPDATED PROJECT LIST	
DATE		REVISIONS	
YEAR 2024 PLAN			
COVER SHEET COLUMBUS, NEBRASKA ONE AND SIX YEAR ROAD PLAN			
DRAWN BY	DATE	CHECKED BY	APPROVED BY
BLI	8-10-2023		
SCALE:	NO SCALE	DRAWING NO.	CITY

Board of Public Roads Classifications and Standards
Form 8 Summary of One-Year Plan

Year Ending: December 31, 2024

Sheet 1 of 1

County: PLATTE		City: COLUMBUS		Village:	
PRIORITY NUMBER	PROJECT NUMBER	LENGTH (Nearest Tenth)	UNIT OF MEASURE	ESTIMATED COST (Thousands)	REMARKS
1	M211(325)	2.7	Miles	32,000	23 St. 32 Ave. to E 11 Ave
2	M211(355)	-	-	275	Downtown Eval IPRR Sep Study
3	M211 (357)	0.5	Miles	2,500	63 Ave, Howard Blvd. to Lost Creek Pkwy
4	M211 (358)	0.2	Miles	350	Storm Sewer Const. 17 St 16-18 Ave
5	M211 (359)	-	-	100	27 St & 33 Ave Light Signal Upgrade
6	M211 (360)	-	-	200	LCP & Wilderness Rd Signal Upgrades
7	M211 (352)	0.4	Miles	3,450	23/Shady Lake, 54 Ave to W Corn Limits
8	M211(366)	0.2	Miles	225	Park Place 10 th Addition
9	M211 (362)	0.4	Miles	350	Centennial Park 8th Add
10	M211 (346)	0.1	Miles	125	Riverside 3 rd Addition
Signature: <i>Richard J. Boyer</i>		Title: City Engineer		Date: August 14, 2023	

Board of Public Roads Classifications and Standards
Form 9 Summary of Six-Year Plan

Six-Year Period Ending: December 31, 2029

Sheet 1 of 2

County: PLATTE		City: COLUMBUS		Village:	
PRIORITY NUMBER	PROJECT NUMBER	LENGTH (Nearest Tenth)	UNIT OF MEASURE	ESTIMATED COST (Thousands)	REMARKS
1	M211 (325)	2.7	Miles	32,000	23 St. 32 Ave. to E 11 Ave Habitat Drive
2	M211(355)			275	Downtown Eval. UPRR Sen Study
3	M211 (357)	0.5	Miles	2,500	63 Ave howard Blvd to Lost Creek Pkwy
4	M211 (358)	0.2	Miles	350	East Park/17 St. from 16-18 Ave S
5	M211 (359)	-	-	100	Signal UG 27 St - 33 Ave
6	M211 (360)	-	-	200	Signal UG Wilderness & I CP
7	M211 (352)	0.4	Miles	2,000	23 Ave/Shady Lake 54 Ave/WCI
8	M211 (366)	0.2	Miles	225	Park Place 10 th Addition
9	M211 (362)	0.4	Miles	350	Centennial Pak 8th Addition
10	M211(346)	0.1	Miles	125	Riverside 3 rd Addition
11	M211(290)	-	-	1,000	Ag Park Drainage
12	M211(272)	1.0	Miles	2,700	Howard Blvd. 33 Ave to 23 St
13	M211(220)	1.6	Miles	2,500	10 Ave Lovers Lane to 5 St
14	M211(289)	0.5	Miles	180	Deerfield Park 2nd Addition
15	M211(44)	-	-	10,300	Storm Sewer East Park/11 St
16	M211(288)	0.3	Miles	2,000	48 Ave. Park to 11 St 11 St 41-48 Ave
17	M211(39)	0.3	Miles	110	Curb & Gutter 6 St 24-26 Ave
18	M211(36)	0.3	Miles	290	14, 15, & 20 Ave between 11 & 12 St
19	M211(264)	0.3	Miles	820	26 Ave from 27-32 St
20	M211(112)	0.3	Miles	260	Crumley Subdivision
21	M211(114)	0.8	Miles	1,100	Sand Subdivision
22	M211(57)			110	Storm Sewer Impr 30 Ave 22-23 St
23	M211(190)	1.4	Miles	2,500	Johannes Addition
24	M211(64)	0.2	Miles	250	Oida Addition
25	M211 (111)	0.3	Miles	360	Gates 1&2 Subdivisions
Signature: 			Title: City Engineer		Date: August 14, 2023

Board of Public Roads Classifications and Standards
Form 9 Summary of Six-Year Plan
 Six-Year Period Ending: December 31, 2029

Sheet 2 of 2

County: PLATTE		City: COLUMBUS		Village:	
PRIORITY NUMBER	PROJECT NUMBER	LENGTH <i>(Nearest Tenth)</i>	UNIT OF MEASURE	ESTIMATED COST <i>(Thousands)</i>	REMARKS
26	M211 (157)	0.3	Miles	340	26 Ave from 3-5 St 25 Ave 3-5 St
27	M211 (324)	1.0	Miles	500	Power House Trail Phase 2
28	M211 (62)	0.3	Miles	350	Air Vista Drive
29	M211 (35)	0.3	Miles	290	12 St. from 12-16 St & 18-19 Ave
30	M211 (118)	0.4	Miles	440	West Parkway 1 & 2 Subdivision
31	M211 (71)	0.1	Miles	115	22 & 25 Ave. between 6&7 St
32	M211 (301)	0.3	Miles	370	21 Ave from 1 to 1/2 Blk N on 3 St
33	M211 (302)	0.4	Miles	525	2-4 St. from 16-17 Ave/14-15 Ave
Signature: 		Title: City Engineer		Date: August 14, 2023	

Board Of Public Roads Classifications And Standards
FORM 10 Notification of Revision of One-Year Plan

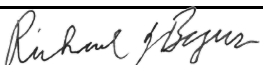
County PLATTE	City: COLUMBUS	Village:
REASON FOR REVISION: <p style="text-align: center;">Private developer subdivision</p>		
LOCATION DESCRIPTION <p style="text-align: center;">Park Place 9th Addition, private developer subdivision</p>		
EXISTING SURFACE TYPE AND STRUCTURES: (Such As Dirt, Gravel, Asphalt, Concrete, Culvert Or Bridge) <p style="text-align: center;">Undeveloped Land</p>		
Average Daily Traffic: 2023 = <u>0</u> , 2043 = <u>150</u>	Classification Type: (As Shown On Functional Classification Map) <p style="text-align: center;">Local</p>	
Proposed Improvement		
Design Standard Number: Municipal	Surfacing	Thickness 6" Width 33'
<input checked="" type="checkbox"/> Grading	<input checked="" type="checkbox"/> Concrete	<input type="checkbox"/> Right Of Way
<input type="checkbox"/> Aggregate	<input checked="" type="checkbox"/> Curb & Gutter	<input checked="" type="checkbox"/> Lighting
<input type="checkbox"/> Armor Coat	<input checked="" type="checkbox"/> Drainage Structures	<input type="checkbox"/> Utility Adjustments
<input type="checkbox"/> Asphalt	<input type="checkbox"/> Erosion Control	<input type="checkbox"/> Fencing
	<input checked="" type="checkbox"/> Sidewalks	
Bridge To Remain In Place:	Roadway Width	Length Type
New Bridge:	Roadway Width	Length Type
Box Culvert:	Span	Rise Length Type
Culvert:	Diameter	Length Type
Bridges and Culverts Sized	<input type="checkbox"/> Yes <input checked="" type="checkbox"/> N/A <input type="checkbox"/> Hydraulic Analysis Pending	
OTHER CONSTRUCTION FEATURES: <p style="text-align: center;">Private development. Roads turned over to city.</p>		
ESTIMATED COST (In Thousands) *OPTIONAL	*COUNTY	*CITY
		*STATE
		*FEDERAL
		*OTHER
		200
		TOTAL
		200
PROJECT LENGTH (Nearest Tenth, State Unit of Measure) 0.1 Miles	Project No.: M211 (365)	
Signature: 	Title: City Engineer	Date: August 14, 2023

Board of Public Roads Classifications and Standards
Form 11 Report of Previous Year
Highway or Street Improvement

Year Ending: December 31, 2023

Sheet 1 of 1

County: PLATTE		City: COLUMBUS			Village:	
PROJECT NUMBER	LENGTH (Nearest Tenth)	UNIT OF MEASURE	PROJECTED COST (Thousands)	CONTRACT PROJECT	OWN FORCES	DATE COMPLETED (Actual or Estimated)
M211(257)	0.8	Miles	3,600	X		5/23
M211 (273)	0.6	Miles	2,400	X		8/23
M211(316)	1.0	Miles	500	X		6/23
M211 (325)	2.7	Miles	32,000	X		Continues
M211 (346)	0.1	Miles	125	X		Continues
M211 (352)	0.4	Miles	3,450	X		Continues
M211 (353)	0.5	Miles	2,650	X		8/23
M211 (355)	-	-	275	X		Continues
M211 (356)	0.3	Miles	950	X		8/23
M211 (357)	0.5	Miles	2,500	X		Continues
M211 (358)	0.2	Miles	350	X		Continues
M211 (359)	-	-		X		Continues
M211 (360)	-	-		X		Continues
M211 (361)	0.1	Miles		X		7/23
M211 (362)	0.4	Miles		X		Continues
M211 (363)	0.3	Miles			X	7/23
Signature: <i>Richard J. Boyer</i>		Title: City Engineer			Date: August 14, 2023	

BOARD OF PUBLIC ROADS CLASSIFICATIONS AND STANDARDS
FORM 7 ONE-AND SIX-YEAR PLAN
HIGHWAY OR STREET IMPROVEMENT PROJECT

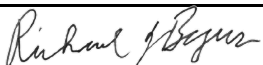
County PLATTE	City: COLUMBUS	Village:				
Location Description: <div style="text-align: center;">12th Street from 12th Avenue to 16th Avenue</div> <hr/> <div style="text-align: center;">12th Street from 18th Avenue to 19th Avenue</div> <hr/>						
EXISTING SURFACE TYPE AND STRUCTURES: (Such As Dirt, Gravel, Asphalt, Concrete, Culvert Or Bridge) <div style="text-align: center;">Gravel</div> <hr/>						
Average Daily Traffic: 2023 = <u>200</u> , 2043 = <u>400</u>	Classification Type: (As Shown On Functional Classification Map) Local					
Proposed Improvement						
Design Standard Number: Municipal	Surfacing Concrete	Thickness 6"				
		Width 33'				
<input checked="" type="checkbox"/> Grading <input checked="" type="checkbox"/> Concrete <input type="checkbox"/> Right Of Way <input type="checkbox"/> Lighting <input type="checkbox"/> Aggregate <input checked="" type="checkbox"/> Curb & Gutter <input checked="" type="checkbox"/> Utility Adjustments <input type="checkbox"/> Armor Coat <input checked="" type="checkbox"/> Drainage Structures <input type="checkbox"/> Fencing <input type="checkbox"/> Asphalt <input checked="" type="checkbox"/> Erosion Control <input checked="" type="checkbox"/> Sidewalks						
Bridge To Remain In Place:	Roadway Width	Length	Type			
New Bridge:	Roadway Width	Length	Type			
Box Culvert:	Span	Rise	Length	Type		
Culvert:	Diameter	Length	Type			
Bridges and Culverts Sized	<input type="checkbox"/> Yes <input checked="" type="checkbox"/> N/A <input type="checkbox"/> Hydraulic Analysis Pending					
OTHER CONSTRUCTION FEATURES: <div style="text-align: center;">Paving over existing Gravel Roadway w/Misc. grading</div> <hr/>						
ESTIMATED COST (In Thousands) *OPTIONAL	*COUNTY	*CITY	*STATE	*FEDERAL	*OTHER	TOTAL
		290				290
PROJECT LENGTH (Nearest Tenth, State Unit of Measure) 0.3 Miles				Project No.: M211(35)		
Signature: 				Title: City Engineer		Date: August 14, 2023

BOARD OF PUBLIC ROADS CLASSIFICATIONS AND STANDARDS
FORM 7 ONE-AND SIX-YEAR PLAN
HIGHWAY OR STREET IMPROVEMENT PROJECT

County PLATTE	City: COLUMBUS	Village:
Location Description: 14th, 15th, and 20th Avenues between 11th Street & 12th Street		
EXISTING SURFACE TYPE AND STRUCTURES: (Such As Dirt, Gravel, Asphalt, Concrete, Culvert Or Bridge) Gravel		
Average Daily Traffic: 2023 = <u>200</u> , 2043 = <u>300</u>	Classification Type: (As Shown On Functional Classification Map) Local	
Proposed Improvement		
Design Standard Number: Municipal	Surfacing Concrete	Thickness 6"
		Width 33'
<input checked="" type="checkbox"/> Grading	<input checked="" type="checkbox"/> Concrete	<input type="checkbox"/> Right Of Way
<input type="checkbox"/> Aggregate	<input checked="" type="checkbox"/> Curb & Gutter	<input checked="" type="checkbox"/> Utility Adjustments
<input type="checkbox"/> Armor Coat	<input checked="" type="checkbox"/> Drainage Structures	<input type="checkbox"/> Fencing
<input type="checkbox"/> Asphalt	<input checked="" type="checkbox"/> Erosion Control	<input checked="" type="checkbox"/> Sidewalks
<input type="checkbox"/> Lighting		
Bridge To Remain In Place:	Roadway Width	Length
		Type
New Bridge:	Roadway Width	Length
		Type
Box Culvert:	Span	Rise
		Length
		Type
Culvert:	Diameter	Length
		Type
Bridges and Culverts Sized	<input type="checkbox"/> Yes <input checked="" type="checkbox"/> N/A <input type="checkbox"/> Hydraulic Analysis Pending	
OTHER CONSTRUCTION FEATURES: Paving over existing Gravel Roadway w/Misc. grading		
ESTIMATED COST (In Thousands) *OPTIONAL	*COUNTY	*CITY
		290
	*STATE	*FEDERAL
	*OTHER	TOTAL
		290
PROJECT LENGTH (Nearest Tenth, State Unit of Measure) 0.3 Miles	Project No.: M211(36)	
Signature: 	Title: City Engineer	Date: August 14, 2023

BOARD OF PUBLIC ROADS CLASSIFICATIONS AND STANDARDS
FORM 7 ONE-AND SIX-YEAR PLAN
HIGHWAY OR STREET IMPROVEMENT PROJECT

County PLATTE	City: COLUMBUS	Village:				
Location Description: Curb & Gutter (6th Street) 24th Avenue to 26th Avenue, north side of 6th Street, 26th Avenue to 27th Avenue <p style="text-align: center;">The above is what remains of this project</p>						
EXISTING SURFACE TYPE AND STRUCTURES: (Such As Dirt, Gravel, Asphalt, Concrete, Culvert Or Bridge) <p style="text-align: center;">20' - 6" Concrete Paving (no curb and gutter)</p>						
Average Daily Traffic: 2023 = <u>300</u> , 2043 = <u>500</u>	Classification Type: (As Shown On Functional Classification Map) <p style="text-align: center;">Local</p>					
Proposed Improvement						
Design Standard Number: <p style="text-align: center;">Municipal</p>	Surfacing <p style="text-align: center;">Concrete</p>	Thickness <p style="text-align: center;">6"</p>				
		Width <p style="text-align: center;">33'</p>				
<input checked="" type="checkbox"/> Grading <input checked="" type="checkbox"/> Concrete <input type="checkbox"/> Right Of Way <input type="checkbox"/> Lighting <input type="checkbox"/> Aggregate <input checked="" type="checkbox"/> Curb & Gutter <input checked="" type="checkbox"/> Utility Adjustments <input type="checkbox"/> Armor Coat <input checked="" type="checkbox"/> Drainage Structures <input type="checkbox"/> Fencing <input type="checkbox"/> Asphalt <input checked="" type="checkbox"/> Erosion Control <input type="checkbox"/> Sidewalks						
Bridge To Remain In Place:	Roadway Width	Length	Type			
New Bridge:	Roadway Width	Length	Type			
Box Culvert:	Span	Rise	Length	Type		
Culvert:	Diameter	Length	Type			
Bridges and Culverts Sized	<input type="checkbox"/> Yes <input checked="" type="checkbox"/> N/A <input type="checkbox"/> Hydraulic Analysis Pending					
OTHER CONSTRUCTION FEATURES: <p style="text-align: center;">Curb & Gutter 5 1/2 ' extension on present 22' paving on both sides makes a 33' paving.</p>						
ESTIMATED COST (In Thousands) *OPTIONAL	*COUNTY	*CITY	*STATE	*FEDERAL	*OTHER	TOTAL
		110				110
PROJECT LENGTH (Nearest Tenth, State Unit of Measure) <p style="text-align: center;">0.3 Miles</p>				Project No.: <p style="text-align: center;">M211(39)</p>		
Signature: 				Title: City Engineer		Date: August 14, 2023

BOARD OF PUBLIC ROADS CLASSIFICATIONS AND STANDARDS
FORM 7 ONE-AND SIX-YEAR PLAN
HIGHWAY OR STREET IMPROVEMENT PROJECT

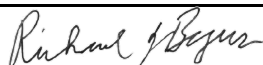
County PLATTE	City: COLUMBUS	Village:				
Location Description: Storm Sewer East Park Addition and 17 Street to Agricultural Park						
EXISTING SURFACE TYPE AND STRUCTURES: (Such As Dirt, Gravel, Asphalt, Concrete, Culvert Or Bridge) Asphalt and Concrete Street Crossings						
Average Daily Traffic: 2023 = <u>NA</u> , 2043 = <u>NA</u>		Classification Type: (As Shown On Functional Classification Map) N/A				
Proposed Improvement						
Design Standard Number: Municipal		Surfacing	Thickness	Width		
<input type="checkbox"/> Grading	<input type="checkbox"/> Concrete	<input type="checkbox"/> Right Of Way	<input type="checkbox"/> Lighting			
<input type="checkbox"/> Aggregate	<input type="checkbox"/> Curb & Gutter	<input type="checkbox"/> Utility Adjustments			
<input type="checkbox"/> Armor Coat	<input checked="" type="checkbox"/> Drainage Structures	<input type="checkbox"/> Fencing			
<input type="checkbox"/> Asphalt	<input checked="" type="checkbox"/> Erosion Control	<input type="checkbox"/> Sidewalks			
Bridge To Remain In Place:	Roadway Width	Length	Type			
New Bridge:	Roadway Width	Length	Type			
Box Culvert:	Span	Rise	Length	Type		
Culvert:	Diameter 48" to 54"	Length	Type RCP			
Bridges and Culverts Sized	<input type="checkbox"/> Yes <input checked="" type="checkbox"/> N/A <input type="checkbox"/> Hydraulic Analysis Pending					
OTHER CONSTRUCTION FEATURES: Assist drainage East Park by enlarging storm sewer system.						
ESTIMATED COST (In Thousands) *OPTIONAL	*COUNTY	*CITY	*STATE	*FEDERAL	*OTHER	TOTAL
		2,000				2,000
PROJECT LENGTH (Nearest Tenth, State Unit of Measure) 0.5 Miles			Project No.: M211(44)			
Signature: 			Title: City Engineer		Date: August 14, 2023	

BOARD OF PUBLIC ROADS CLASSIFICATIONS AND STANDARDS
FORM 7 ONE-AND SIX-YEAR PLAN
HIGHWAY OR STREET IMPROVEMENT PROJECT

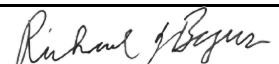
County PLATTE	City: COLUMBUS	Village:				
Location Description: <p style="text-align: center;">Storm Sewer Improvement: 30th Avenue from 22nd to 23rd Streets</p> <p style="text-align: center;">20th Street from 30th Avenue to 33rd Avenue</p>						
EXISTING SURFACE TYPE AND STRUCTURES: (Such As Dirt, Gravel, Asphalt, Concrete, Culvert Or Bridge) <p style="text-align: center;">Concrete</p>						
Average Daily Traffic: 2023 = <u>400</u> , 2043 = <u>500</u>	Classification Type: (As Shown On Functional Classification Map) <p style="text-align: center;">Local</p>					
Proposed Improvement						
Design Standard Number:	Surfacing	Thickness				
<input type="checkbox"/> Grading <input type="checkbox"/> Concrete <input type="checkbox"/> Right Of Way <input type="checkbox"/> Lighting <input type="checkbox"/> Aggregate <input checked="" type="checkbox"/> Curb & Gutter <input type="checkbox"/> Utility Adjustments <input type="checkbox"/> Armor Coat <input checked="" type="checkbox"/> Drainage Structures <input type="checkbox"/> Fencing <input type="checkbox"/> Asphalt <input checked="" type="checkbox"/> Erosion Control <input type="checkbox"/> Sidewalks						
Bridge To Remain In Place:	Roadway Width	Length	Type			
New Bridge:	Roadway Width	Length	Type			
Box Culvert:	Span	Rise	Length	Type		
Culvert:	Diameter 18"	Length	Type RCP			
Bridges and Culverts Sized	<input type="checkbox"/> Yes <input checked="" type="checkbox"/> N/A <input type="checkbox"/> Hydraulic Analysis Pending					
OTHER CONSTRUCTION FEATURES: <p style="text-align: center;">Improve storm sewer drainage in this area.</p>						
ESTIMATED COST (In Thousands) *OPTIONAL	*COUNTY	*CITY	*STATE	*FEDERAL	*OTHER	TOTAL
		110				110
PROJECT LENGTH (Nearest Tenth, State Unit of Measure)				Project No.:		
				M211(57)		
Signature: 				Title: City Engineer		Date: August 14, 2023

BOARD OF PUBLIC ROADS CLASSIFICATIONS AND STANDARDS
FORM 7 ONE-AND SIX-YEAR PLAN
HIGHWAY OR STREET IMPROVEMENT PROJECT

County PLATTE	City: COLUMBUS	Village:				
Location Description: <p style="text-align: center;">Air Vista Drive southwest from 30th Street to point 211' north of 27th Street</p> <p style="text-align: center;">Where it joins 33' concrete paving.</p>						
EXISTING SURFACE TYPE AND STRUCTURES: (Such As Dirt, Gravel, Asphalt, Concrete, Culvert Or Bridge) <p style="text-align: center;">Gravel</p>						
Average Daily Traffic: 2023 = <u>100</u> , 2043 = <u>200</u>		Classification Type: (As Shown On Functional Classification Map) <p style="text-align: center;">Local</p>				
Proposed Improvement						
Design Standard Number: Municipal		Surfacing Concrete	Thickness 6"	Width 33'		
<input checked="" type="checkbox"/> Grading	<input checked="" type="checkbox"/> Concrete	<input type="checkbox"/> Right Of Way	<input checked="" type="checkbox"/> Lighting			
<input type="checkbox"/> Aggregate	<input checked="" type="checkbox"/> Curb & Gutter	<input checked="" type="checkbox"/> Utility Adjustments			
<input type="checkbox"/> Armor Coat	<input checked="" type="checkbox"/> Drainage Structures	<input type="checkbox"/> Fencing			
<input type="checkbox"/> Asphalt	<input checked="" type="checkbox"/> Erosion Control	<input checked="" type="checkbox"/> Sidewalks			
Bridge To Remain In Place:	Roadway Width	Length	Type			
New Bridge:	Roadway Width	Length	Type			
Box Culvert:	Span	Rise	Length	Type		
Culvert:	Diameter	Length		Type		
Bridges and Culverts Sized	<input type="checkbox"/> Yes <input checked="" type="checkbox"/> N/A <input type="checkbox"/> Hydraulic Analysis Pending					
OTHER CONSTRUCTION FEATURES: <p style="text-align: center;">Paving over existing Gravel Roadway w/Misc. grading</p>						
ESTIMATED COST (In Thousands) *OPTIONAL	*COUNTY	*CITY	*STATE	*FEDERAL	*OTHER	TOTAL
		350				350
PROJECT LENGTH (Nearest Tenth, State Unit of Measure) 0.3 Miles			Project No.: M211(62)			
Signature: 			Title: City Engineer		Date: August 14, 2023	

BOARD OF PUBLIC ROADS CLASSIFICATIONS AND STANDARDS
FORM 7 ONE-AND SIX-YEAR PLAN
HIGHWAY OR STREET IMPROVEMENT PROJECT

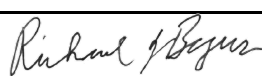
County PLATTE	City: COLUMBUS	Village:				
Location Description: 12th Street, 37th Avenue to 38 1/2 Avenue - 40 1/2 Avenue to 41st Avenue 13th Street, 40 1/2 Avenue to 41st Avenue, 37th Avenue, 13th Street 1/2 block South 38th Avenue, 12th Street to 13th Street, 1/2 block North, Oida Addition						
EXISTING SURFACE TYPE AND STRUCTURES: (Such As Dirt, Gravel, Asphalt, Concrete, Culvert Or Bridge) Gravel						
Average Daily Traffic: 2023 = <u>100</u> , 2043 = <u>200</u>	Classification Type: (As Shown On Functional Classification Map) Local					
Proposed Improvement						
Design Standard Number: Municipal	Surfacing Concrete	Thickness 6" Width 33'				
<input checked="" type="checkbox"/> Grading <input checked="" type="checkbox"/> Concrete <input type="checkbox"/> Right Of Way <input type="checkbox"/> Lighting <input type="checkbox"/> Aggregate <input checked="" type="checkbox"/> Curb & Gutter <input checked="" type="checkbox"/> Utility Adjustments <input type="checkbox"/> Armor Coat <input checked="" type="checkbox"/> Drainage Structures <input type="checkbox"/> Fencing <input type="checkbox"/> Asphalt <input checked="" type="checkbox"/> Erosion Control <input type="checkbox"/> Sidewalks						
Bridge To Remain In Place:	Roadway Width	Length	Type			
New Bridge:	Roadway Width	Length	Type			
Box Culvert:	Span	Rise	Length	Type		
Culvert:	Diameter	Length	Type			
Bridges and Culverts Sized	<input type="checkbox"/> Yes <input checked="" type="checkbox"/> N/A <input type="checkbox"/> Hydraulic Analysis Pending					
OTHER CONSTRUCTION FEATURES: 33' Concrete, Curb & Gutter and Storm Sewer						
ESTIMATED COST (In Thousands) *OPTIONAL	*COUNTY	*CITY	*STATE	*FEDERAL	*OTHER	TOTAL
		260				260
PROJECT LENGTH (Nearest Tenth, State Unit of Measure) 0.2 Miles				Project No.: M211(64)		
Signature: 				Title: City Engineer		Date: August 14, 2023

BOARD OF PUBLIC ROADS CLASSIFICATIONS AND STANDARDS
FORM 7 ONE-AND SIX-YEAR PLAN
HIGHWAY OR STREET IMPROVEMENT PROJECT

County PLATTE	City: COLUMBUS	Village:				
Location Description: <div style="text-align: center;">22nd Avenue between 6th Street to 7th Street</div> <hr/> <div style="text-align: center;">25th Avenue between 6th Street to 7th Street</div>						
EXISTING SURFACE TYPE AND STRUCTURES: (Such As Dirt, Gravel, Asphalt, Concrete, Culvert Or Bridge) <div style="text-align: center;">Gravel</div>						
Average Daily Traffic: 2023 = <u>100</u> , 2043 = <u>200</u>		Classification Type: (As Shown On Functional Classification Map) Local				
Proposed Improvement						
Design Standard Number: Municipal		Surfacing Concrete	Thickness 6"	Width 33'		
<input checked="" type="checkbox"/> Grading	<input checked="" type="checkbox"/> Concrete	<input type="checkbox"/> Right Of Way	<input checked="" type="checkbox"/> Lighting			
<input type="checkbox"/> Aggregate	<input checked="" type="checkbox"/> Curb & Gutter	<input checked="" type="checkbox"/> Utility Adjustments			
<input type="checkbox"/> Armor Coat	<input checked="" type="checkbox"/> Drainage Structures	<input type="checkbox"/> Fencing			
<input type="checkbox"/> Asphalt	<input checked="" type="checkbox"/> Erosion Control	<input checked="" type="checkbox"/> Sidewalks			
Bridge To Remain In Place:	Roadway Width	Length	Type			
New Bridge:	Roadway Width	Length	Type			
Box Culvert:	Span	Rise	Length	Type		
Culvert:	Diameter	Length	Type			
Bridges and Culverts Sized	<input type="checkbox"/> Yes <input checked="" type="checkbox"/> N/A <input type="checkbox"/> Hydraulic Analysis Pending					
OTHER CONSTRUCTION FEATURES: <div style="text-align: center;">33' Concrete, Curb & Gutter and Storm Sewer</div>						
ESTIMATED COST (In Thousands) *OPTIONAL	*COUNTY	*CITY	*STATE	*FEDERAL	*OTHER	TOTAL
		115				115
PROJECT LENGTH (Nearest Tenth, State Unit of Measure) 0.1 Miles			Project No.: M211(71)			
Signature: 			Title: City Engineer		Date: August 14, 2023	

BOARD OF PUBLIC ROADS CLASSIFICATIONS AND STANDARDS
FORM 7 ONE-AND SIX-YEAR PLAN
HIGHWAY OR STREET IMPROVEMENT PROJECT

County PLATTE	City: COLUMBUS	Village:
Location Description: Gates 1 st Subdivision – 2 nd Avenue, 8 th Street to 10 th Street, 10 th Street, 3 rd Avenue to 2 nd Avenue <hr/> Gates 2 nd Subdivision – 2 nd Avenue south and southeasterly and return to 9 th Avenue.		
EXISTING SURFACE TYPE AND STRUCTURES: (Such As Dirt, Gravel, Asphalt, Concrete, Culvert Or Bridge) <hr/> <p style="text-align: center;">Gravel</p> <hr/>		
Average Daily Traffic: 2023 = <u>100</u> , 2043 = <u>200</u>	Classification Type: (As Shown On Functional Classification Map) Local	
Proposed Improvement		
Design Standard Number: Municipal	Surfacing Concrete	Thickness 6"
		Width 33'
<input checked="" type="checkbox"/> Grading	<input checked="" type="checkbox"/> Concrete	<input type="checkbox"/> Right Of Way
<input type="checkbox"/> Aggregate	<input checked="" type="checkbox"/> Curb & Gutter	<input checked="" type="checkbox"/> Lighting
<input type="checkbox"/> Armor Coat	<input checked="" type="checkbox"/> Drainage Structures	<input type="checkbox"/> Utility Adjustments
<input type="checkbox"/> Asphalt	<input checked="" type="checkbox"/> Erosion Control	<input type="checkbox"/> Fencing
	<input checked="" type="checkbox"/> Sidewalks	
Bridge To Remain In Place:	Roadway Width	Length
		Type
New Bridge:	Roadway Width	Length
		Type
Box Culvert:	Span	Rise
		Length
		Type
Culvert:	Diameter	Length
		Type
Bridges and Culverts Sized	<input type="checkbox"/> Yes <input checked="" type="checkbox"/> N/A <input type="checkbox"/> Hydraulic Analysis Pending	
OTHER CONSTRUCTION FEATURES: 33' Concrete, Curb & Gutter and Storm Sewer <hr/> <hr/> <hr/>		
ESTIMATED COST (In Thousands) *OPTIONAL	*COUNTY	*CITY
		360
	*STATE	*FEDERAL
	*OTHER	TOTAL
		360
PROJECT LENGTH (Nearest Tenth, State Unit of Measure) 0.3 Miles	Project No.: M211(111)	
Signature: 	Title: City Engineer	Date: August 14, 2023

BOARD OF PUBLIC ROADS CLASSIFICATIONS AND STANDARDS
FORM 7 ONE-AND SIX-YEAR PLAN
HIGHWAY OR STREET IMPROVEMENT PROJECT

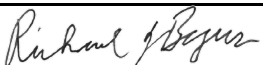
County PLATTE	City: COLUMBUS	Village:				
Location Description: Crumley Subdivision – 6th Street and 3rd Avenue – 5th Street east to City Limits, also 2nd Avenue cul-de-sac.						
EXISTING SURFACE TYPE AND STRUCTURES: (Such As Dirt, Gravel, Asphalt, Concrete, Culvert Or Bridge) Gravel						
Average Daily Traffic: 2023 = <u>100</u> , 2043 = <u>200</u>		Classification Type: (As Shown On Functional Classification Map) Local				
Proposed Improvement						
Design Standard Number: Municipal		Surfacing Concrete	Thickness 6"	Width 33'		
<input checked="" type="checkbox"/> Grading	<input checked="" type="checkbox"/> Concrete	<input type="checkbox"/> Right Of Way	<input checked="" type="checkbox"/> Lighting			
<input type="checkbox"/> Aggregate	<input checked="" type="checkbox"/> Curb & Gutter	<input checked="" type="checkbox"/> Utility Adjustments			
<input type="checkbox"/> Armor Coat	<input checked="" type="checkbox"/> Drainage Structures	<input type="checkbox"/> Fencing			
<input type="checkbox"/> Asphalt	<input checked="" type="checkbox"/> Erosion Control	<input checked="" type="checkbox"/> Sidewalks			
Bridge To Remain In Place:	Roadway Width	Length	Type			
New Bridge:	Roadway Width	Length	Type			
Box Culvert:	Span	Rise	Length	Type		
Culvert:	Diameter	Length		Type		
Bridges and Culverts Sized	<input type="checkbox"/> Yes <input checked="" type="checkbox"/> N/A <input type="checkbox"/> Hydraulic Analysis Pending					
OTHER CONSTRUCTION FEATURES: 33' Concrete, Curb & Gutter and Storm Sewer						
ESTIMATED COST (In Thousands) *OPTIONAL	*COUNTY	*CITY	*STATE	*FEDERAL	*OTHER	TOTAL
		260				260
PROJECT LENGTH (Nearest Tenth, State Unit of Measure) 0.1 Miles			Project No.: M211(112)			
Signature: 			Title: City Engineer		Date: August 14, 2023	

BOARD OF PUBLIC ROADS CLASSIFICATIONS AND STANDARDS
FORM 7 ONE-AND SIX-YEAR PLAN
HIGHWAY OR STREET IMPROVEMENT PROJECT

County PLATTE	City: COLUMBUS	Village:				
Location Description: Sand Subdivision and (Replat Part) of Sand Subdivision, 17 th Street, Public Access Road <hr/> From East 12 th Avenue & East 11 th Avenue from 17 th Street north to Public Access <hr/> Road, 17 th Street from East 11 th Avenue west. <hr/>						
EXISTING SURFACE TYPE AND STRUCTURES: (Such As Dirt, Gravel, Asphalt, Concrete, Culvert Or Bridge) <hr/> <p style="text-align: center;">Gravel</p> <hr/>						
Average Daily Traffic: 2023 = <u>400</u> , 2043 = <u>600</u>	Classification Type: (As Shown On Functional Classification Map) <p style="text-align: center;">Local</p>					
Proposed Improvement						
Design Standard Number: <p style="text-align: center;"><u>Municipal</u></p>	Surfacing <p style="text-align: center;">Concrete</p>	Thickness <p style="text-align: center;">8"</p>				
		Width <p style="text-align: center;">33'</p>				
<input checked="" type="checkbox"/> Grading <input checked="" type="checkbox"/> Concrete <input type="checkbox"/> Right Of Way <input checked="" type="checkbox"/> Lighting <input type="checkbox"/> Aggregate <input checked="" type="checkbox"/> Curb & Gutter <input checked="" type="checkbox"/> Utility Adjustments <input type="checkbox"/> Armor Coat <input checked="" type="checkbox"/> Drainage Structures <input type="checkbox"/> Fencing <input type="checkbox"/> Asphalt <input checked="" type="checkbox"/> Erosion Control <input checked="" type="checkbox"/> Sidewalks						
Bridge To Remain In Place:	Roadway Width	Length	Type			
New Bridge:	Roadway Width	Length	Type			
Box Culvert:	Span	Rise	Length Type			
Culvert:	Diameter	Length	Type			
Bridges and Culverts Sized	<input type="checkbox"/> Yes <input checked="" type="checkbox"/> N/A <input type="checkbox"/> Hydraulic Analysis Pending					
OTHER CONSTRUCTION FEATURES: <hr/> <p style="text-align: center;">33' Concrete, Curb & Gutter and Storm Sewer</p> <hr/>						
ESTIMATED COST (In Thousands) *OPTIONAL	*COUNTY	*CITY	*STATE	*FEDERAL	*OTHER	TOTAL
		1130				1130
PROJECT LENGTH (Nearest Tenth, State Unit of Measure) <p style="text-align: center;">0.8 Miles</p>				Project No.: <p style="text-align: center;">M211(114)</p>		
Signature: 				Title: City Engineer		Date: August 14, 2023

BOARD OF PUBLIC ROADS CLASSIFICATIONS AND STANDARDS
FORM 7 ONE-AND SIX-YEAR PLAN
HIGHWAY OR STREET IMPROVEMENT PROJECT

County PLATTE	City: COLUMBUS	Village:				
Location Description: West Parkway 1st and 2nd Subdivisions; 12th Street - Munroe Avenue to 46th Avenue; 13th Street - 46th Avenue to 48th Avenue; 14th Street - 248' East of Munroe Avenue to 48th Avenue; Munroe Avenue - 11th Street to 14th Street; 46th Avenue - 11th Street to 14th Street						
EXISTING SURFACE TYPE AND STRUCTURES: (Such As Dirt, Gravel, Asphalt, Concrete, Culvert Or Bridge) _____ _____ _____ <p style="text-align: center;">Gravel</p> _____ _____						
Average Daily Traffic: 2023 = <u>100</u> , 2043 = <u>200</u>		Classification Type: (As Shown On Functional Classification Map) <p style="text-align: center;">Local</p>				
Proposed Improvement						
Design Standard Number: Municipal		Surfacing Concrete	Thickness 6"	Width 33'		
<input checked="" type="checkbox"/> Grading	<input checked="" type="checkbox"/> Concrete	<input type="checkbox"/> Right Of Way	<input checked="" type="checkbox"/> Lighting			
<input type="checkbox"/> Aggregate	<input checked="" type="checkbox"/> Curb & Gutter	<input checked="" type="checkbox"/> Utility Adjustments		_____		
<input type="checkbox"/> Armor Coat	<input checked="" type="checkbox"/> Drainage Structures	<input type="checkbox"/> Fencing	_____			
<input type="checkbox"/> Asphalt	<input type="checkbox"/> Erosion Control	<input checked="" type="checkbox"/> Sidewalks	_____			
Bridge To Remain In Place:	Roadway Width	Length	Type			
New Bridge:	Roadway Width	Length	Type			
Box Culvert:	Span	Rise	Length	Type		
Culvert:	Diameter	Length	Type			
Bridges and Culverts Sized	<input type="checkbox"/> Yes <input checked="" type="checkbox"/> N/A <input type="checkbox"/> Hydraulic Analysis Pending					
OTHER CONSTRUCTION FEATURES: _____ _____ _____ _____ _____ _____ _____ _____						
ESTIMATED COST (In Thousands) *OPTIONAL	*COUNTY	*CITY	*STATE	*FEDERAL	*OTHER	TOTAL
		440				440
PROJECT LENGTH (Nearest Tenth, State Unit of Measure) 0.4 Miles				Project No.: M211(118)		
Signature: 			Title: City Engineer		Date: August 14, 2023	

BOARD OF PUBLIC ROADS CLASSIFICATIONS AND STANDARDS
FORM 7 ONE-AND SIX-YEAR PLAN
HIGHWAY OR STREET IMPROVEMENT PROJECT

County PLATTE	City: COLUMBUS	Village:				
Location Description: 26th Avenue from 3 rd to 5 th Streets; 25 th Avenue from 4 th to 5 th Streets; 24 th Avenue from 4 th Street North and South ½ Block; 4 th Street from 23 rd to 24 th Avenue						
EXISTING SURFACE TYPE AND STRUCTURES: (Such As Dirt, Gravel, Asphalt, Concrete, Culvert Or Bridge) Gravel						
Average Daily Traffic: 2023 = <u>200</u> , 2043 = <u>300</u>	Classification Type: (As Shown On Functional Classification Map) Local					
Proposed Improvement						
Design Standard Number: <u>Municipal</u>	Surfacing Concrete	Thickness 6" Width 33'				
<input checked="" type="checkbox"/> Grading	<input checked="" type="checkbox"/> Concrete	<input type="checkbox"/> Right Of Way				
<input type="checkbox"/> Aggregate	<input checked="" type="checkbox"/> Curb & Gutter	<input checked="" type="checkbox"/> Lighting				
<input type="checkbox"/> Armor Coat	<input checked="" type="checkbox"/> Drainage Structures	<input type="checkbox"/> Utility Adjustments				
<input type="checkbox"/> Asphalt	<input checked="" type="checkbox"/> Erosion Control	<input type="checkbox"/> Fencing				
	<input checked="" type="checkbox"/> Sidewalks					
Bridge To Remain In Place:	Roadway Width	Length	Type			
New Bridge:	Roadway Width	Length	Type			
Box Culvert:	Span	Rise	Length	Type		
Culvert:	Diameter	Length	Type			
Bridges and Culverts Sized	<input type="checkbox"/> Yes <input checked="" type="checkbox"/> N/A <input type="checkbox"/> Hydraulic Analysis Pending					
OTHER CONSTRUCTION FEATURES: 33' Concrete Paving, Curb & Gutter, Storm Sewer						
ESTIMATED COST (In Thousands) *OPTIONAL	*COUNTY	*CITY	*STATE	*FEDERAL	*OTHER	TOTAL
		340				340
PROJECT LENGTH (Nearest Tenth, State Unit of Measure) .3 Miles				Project No.: M211(157)		
Signature: 				Title: City Engineer		Date: August 14, 2023

BOARD OF PUBLIC ROADS CLASSIFICATIONS AND STANDARDS
FORM 7 ONE-AND SIX-YEAR PLAN
HIGHWAY OR STREET IMPROVEMENT PROJECT

County PLATTE	City: COLUMBUS	Village:				
Location Description: <p style="text-align: center;">Johannes Subdivision</p>						
EXISTING SURFACE TYPE AND STRUCTURES: (Such As Dirt, Gravel, Asphalt, Concrete, Culvert Or Bridge) <p style="text-align: center;">Gravel</p>						
Average Daily Traffic: 2023 = <u>150</u> , 2043 = <u>300</u>		Classification Type: (As Shown On Functional Classification Map) <p style="text-align: center;">Local</p>				
Proposed Improvement						
Design Standard Number: <p style="text-align: center;">Municipal</p>	Surfacing <p style="text-align: center;">Concrete</p>	Thickness <p style="text-align: center;">6"</p>				
		Width <p style="text-align: center;">33'</p>				
<input checked="" type="checkbox"/> Grading <input checked="" type="checkbox"/> Concrete <input type="checkbox"/> Right Of Way <input type="checkbox"/> Lighting <input type="checkbox"/> Aggregate <input checked="" type="checkbox"/> Curb & Gutter <input checked="" type="checkbox"/> Utility Adjustments <input type="checkbox"/> Armor Coat <input checked="" type="checkbox"/> Drainage Structures <input type="checkbox"/> Fencing <input type="checkbox"/> Asphalt <input checked="" type="checkbox"/> Erosion Control <input checked="" type="checkbox"/> Sidewalks						
Bridge To Remain In Place:	Roadway Width	Length	Type			
New Bridge:	Roadway Width	Length	Type			
Box Culvert:	Span	Rise	Length	Type		
Culvert:	Diameter	Length	Type			
Bridges and Culverts Sized	<input type="checkbox"/> Yes <input checked="" type="checkbox"/> N/A <input type="checkbox"/> Hydraulic Analysis Pending					
OTHER CONSTRUCTION FEATURES: <p style="text-align: center;">Paving over existing Gravel Roadway w/Misc. grading</p>						
ESTIMATED COST (In Thousands) *OPTIONAL	*COUNTY	*CITY	*STATE	*FEDERAL	*OTHER	TOTAL
		2,500				2,500
PROJECT LENGTH (Nearest Tenth, State Unit of Measure) <p style="text-align: center;">1.4 Miles</p>				Project No.: <p style="text-align: center;">M211(190)</p>		
Signature: 				Title: City Engineer		Date: August 14, 2023

BOARD OF PUBLIC ROADS CLASSIFICATIONS AND STANDARDS
FORM 7 ONE-AND SIX-YEAR PLAN
HIGHWAY OR STREET IMPROVEMENT PROJECT

County PLATTE	City: COLUMBUS	Village:				
Location Description: 10 th Avenue Lovers Lane to 5 th Street, Lovers Lane 5 th Street to 10 th Avenue, 7 th Avenue from Lovers Lane to South 5 th Street East to 3 rd Avenue.						
EXISTING SURFACE TYPE AND STRUCTURES: (Such As Dirt, Gravel, Asphalt, Concrete, Culvert Or Bridge) Asphalt						
Average Daily Traffic: 2023 = <u>765</u> , 2043 = <u>950</u>	Classification Type: (As Shown On Functional Classification Map) Collector					
Proposed Improvement						
Design Standard Number: <u>Municipal</u>	Surfacing Concrete	Thickness 8"				
		Width 41'				
<input checked="" type="checkbox"/> Grading <input checked="" type="checkbox"/> Concrete <input type="checkbox"/> Right Of Way <input type="checkbox"/> Lighting <input type="checkbox"/> Aggregate <input checked="" type="checkbox"/> Curb & Gutter <input checked="" type="checkbox"/> Utility Adjustments <input type="checkbox"/> Armor Coat <input checked="" type="checkbox"/> Drainage Structures <input type="checkbox"/> Fencing <input type="checkbox"/> Asphalt <input checked="" type="checkbox"/> Erosion Control <input checked="" type="checkbox"/> Sidewalks						
Bridge To Remain In Place:	Roadway Width	Length	Type			
New Bridge:	Roadway Width	Length	Type			
Box Culvert:	Span	Rise	Length	Type		
Culvert:	Diameter	Length	Type			
Bridges and Culverts Sized	<input type="checkbox"/> Yes <input checked="" type="checkbox"/> N/A <input type="checkbox"/> Hydraulic Analysis Pending					
OTHER CONSTRUCTION FEATURES: 41' Concrete Paving, Curb & Gutter with Storm Sewer.						
ESTIMATED COST (In Thousands) *OPTIONAL	*COUNTY	*CITY	*STATE	*FEDERAL	*OTHER	TOTAL
		2500				2,500
PROJECT LENGTH (Nearest Tenth, State Unit of Measure) 1.6 Miles				Project No.: M211(220)		
Signature: 				Title: City Engineer		Date: August 14, 2023

BOARD OF PUBLIC ROADS CLASSIFICATIONS AND STANDARDS
FORM 7 ONE-AND SIX-YEAR PLAN
HIGHWAY OR STREET IMPROVEMENT PROJECT

County PLATTE	City: COLUMBUS	Village:				
Location Description: <p style="text-align: center;">East 14th Avenue from 23rd Street north ¾ mile</p>						
EXISTING SURFACE TYPE AND STRUCTURES: (Such As Dirt, Gravel, Asphalt, Concrete, Culvert Or Bridge) <p style="text-align: center;">Asphalt rural section, 2 lane</p>						
Average Daily Traffic: 2023 = <u>1350</u> , 2043 = <u>1800</u>	Classification Type: (As Shown On Functional Classification Map) <p style="text-align: center;">Collector</p>					
Proposed Improvement						
Design Standard Number: <p style="text-align: center;">Municipal</p>	Surfacing <p style="text-align: center;">Concrete</p>	Thickness <p style="text-align: center;">8"</p>				
		Width <p style="text-align: center;">41'</p>				
<input checked="" type="checkbox"/> Grading	<input checked="" type="checkbox"/> Concrete	<input checked="" type="checkbox"/> Right Of Way				
<input type="checkbox"/> Aggregate	<input checked="" type="checkbox"/> Curb & Gutter	<input checked="" type="checkbox"/> Utility Adjustments				
<input type="checkbox"/> Armor Coat	<input checked="" type="checkbox"/> Drainage Structures	<input type="checkbox"/> Fencing				
<input type="checkbox"/> Asphalt	<input checked="" type="checkbox"/> Erosion Control	<input type="checkbox"/> Sidewalks				
<input type="checkbox"/> Lighting						
Bridge To Remain In Place:	Roadway Width	Length	Type			
New Bridge: X	Roadway Width	Length	Type			
Box Culvert:	Span	Rise	Length	Type		
Culvert:	Diameter	Length	Type			
Bridges and Culverts Sized	<input type="checkbox"/> Yes <input checked="" type="checkbox"/> N/A <input type="checkbox"/> Hydraulic Analysis Pending					
OTHER CONSTRUCTION FEATURES: <p style="text-align: center;">Federal Funds, Purchase Program and Assessments</p>						
ESTIMATED COST (In Thousands) *OPTIONAL	*COUNTY	*CITY	*STATE	*FEDERAL	*OTHER	TOTAL
		1900				1900
PROJECT LENGTH (Nearest Tenth, State Unit of Measure) <p style="text-align: center;">0.8 MILES</p>				Project No.: <p style="text-align: center;">M211(257)</p>		
Signature: <i>Richard J. Boyer</i>				Title: <p style="text-align: center;">City Engineer</p>		Date: <p style="text-align: center;">August 14, 2023</p>

BOARD OF PUBLIC ROADS CLASSIFICATIONS AND STANDARDS
FORM 7 ONE-AND SIX-YEAR PLAN
HIGHWAY OR STREET IMPROVEMENT PROJECT

County PLATTE	City: COLUMBUS	Village:				
Location Description: 26th Avenue from 27rd Street to 32nd Street						
EXISTING SURFACE TYPE AND STRUCTURES: (Such As Dirt, Gravel, Asphalt, Concrete, Culvert Or Bridge) Concrete						
Average Daily Traffic: 2023 = <u>5450</u> , 2043 = <u>7500</u>	Classification Type: (As Shown On Functional Classification Map) Collector					
Proposed Improvement						
Design Standard Number: Municipal	Surfacing Concrete 8" Thickness 33' Width					
<input type="checkbox"/> Grading	<input checked="" type="checkbox"/> Concrete	<input type="checkbox"/> Right Of Way				
<input type="checkbox"/> Aggregate	<input checked="" type="checkbox"/> Curb & Gutter	<input checked="" type="checkbox"/> Utility Adjustments				
<input type="checkbox"/> Armor Coat	<input type="checkbox"/> Drainage Structures	<input type="checkbox"/> Fencing				
<input type="checkbox"/> Asphalt	<input checked="" type="checkbox"/> Erosion Control	<input type="checkbox"/> Sidewalks				
<input type="checkbox"/> Lighting						
Bridge To Remain In Place:	Roadway Width	Length	Type			
New Bridge:	Roadway Width	Length	Type			
Box Culvert:	Span	Rise	Length	Type		
Culvert:	Diameter	Length	Type			
Bridges and Culverts Sized	<input type="checkbox"/> Yes <input checked="" type="checkbox"/> N/A <input type="checkbox"/> Hydraulic Analysis Pending					
OTHER CONSTRUCTION FEATURES: Federal Funds Purchase Program						
ESTIMATED COST (In Thousands) *OPTIONAL	*COUNTY	*CITY	*STATE	*FEDERAL	*OTHER	TOTAL
		820				820
PROJECT LENGTH (Nearest Tenth, State Unit of Measure) 0.3 MILES				Project No.: M211(264)		
Signature: <i>Richard J. Beggs</i>				Title: CITY ENGINEER		Date: August 14, 2023

BOARD OF PUBLIC ROADS CLASSIFICATIONS AND STANDARDS
FORM 7 ONE-AND SIX-YEAR PLAN
HIGHWAY OR STREET IMPROVEMENT PROJECT

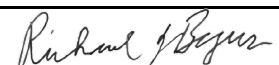
County PLATTE	City: COLUMBUS	Village:				
Location Description: <div style="text-align: center;">Howard. Blvd -33rd Avenue to 41st Avenue</div> <hr/> <div style="text-align: center;">14th Street – 33rd Avenue to 23rd Street.</div>						
EXISTING SURFACE TYPE AND STRUCTURES: (Such As Dirt, Gravel, Asphalt, Concrete, Culvert Or Bridge) <div style="text-align: center;">Asphalt over concrete (Approx. 0.7 miles)</div> <hr/> <div style="text-align: center;">Concrete (Approx. 0.3 Miles)</div>						
Average Daily Traffic: 2023 = <u>6300</u> , 2043 = <u>8500</u>		Classification Type: (As Shown On Functional Classification Map) Principal Arterial				
Proposed Improvement						
Design Standard Number: Municipal		Concrete	9" Thick	41'Wide		
<input type="checkbox"/> Grading	<input checked="" type="checkbox"/> Concrete	<input type="checkbox"/> Right Of Way	<input type="checkbox"/> Lighting			
<input type="checkbox"/> Aggregate	<input checked="" type="checkbox"/> Curb & Gutter	<input checked="" type="checkbox"/> Utility Adjustments			
<input type="checkbox"/> Armor Coat	<input checked="" type="checkbox"/> Drainage Structures	<input type="checkbox"/> Fencing			
<input type="checkbox"/> Asphalt	<input type="checkbox"/> Erosion Control	<input checked="" type="checkbox"/> Sidewalks			
Bridge To Remain In Place:	Roadway Width	Length		Type		
New Bridge:	Roadway Width	Length		Type		
Box Culvert:	Span	Rise	Length	Type		
Culvert:	Diameter	Length			Type	
Bridges and Culverts Sized	<input type="checkbox"/> Yes <input checked="" type="checkbox"/> N/A <input type="checkbox"/> Hydraulic Analysis Pending					
OTHER CONSTRUCTION FEATURES: <div style="text-align: center;">41' Concrete Paving, Curb & Gutter with storm sewer</div> <hr/> <div style="text-align: center;">Federal Funds Purchase Program</div> <hr/> <div style="text-align: center;">Construct ADA compliant ramps</div>						
ESTIMATED COST (In Thousands) *OPTIONAL	*COUNTY	*CITY	*STATE	*FEDERAL	*OTHER	TOTAL
		2700				2700
PROJECT LENGTH (Nearest Tenth, State Unit of Measure) 1.0 Mile				Project No.: M211(272)		
Signature: 			Title: City Engineer		Date: August 14, 2023	

BOARD OF PUBLIC ROADS CLASSIFICATIONS AND STANDARDS
FORM 7 ONE-AND SIX-YEAR PLAN
HIGHWAY OR STREET IMPROVEMENT PROJECT

County PLATTE	City: COLUMBUS	Village:				
Location Description: 48 th Ave. Bradshaw Park Entrance to 11 th St., 11 th St. from 48 th Ave. to 41 st Ave.						
EXISTING SURFACE TYPE AND STRUCTURES: (Such As Dirt, Gravel, Asphalt, Concrete, Culvert Or Bridge) Asphalt & concrete rural section						
Average Daily Traffic: 2023 = <u>1300</u> , 2043 = <u>2300</u>		Classification Type: (As Shown On Functional Classification Map) Collector				
Proposed Improvement						
Design Standard Number: Municipal		Surfacing Concrete	Thickness 9"	Width 33'		
<input checked="" type="checkbox"/> Grading	<input checked="" type="checkbox"/> Concrete	<input type="checkbox"/> Right Of Way	<input checked="" type="checkbox"/> Lighting			
<input type="checkbox"/> Aggregate	<input checked="" type="checkbox"/> Curb & Gutter	<input checked="" type="checkbox"/> Utility Adjustments			
<input type="checkbox"/> Armor Coat	<input checked="" type="checkbox"/> Drainage Structures	<input type="checkbox"/> Fencing			
<input type="checkbox"/> Asphalt	<input checked="" type="checkbox"/> Erosion Control	<input checked="" type="checkbox"/> Sidewalks			
Bridge To Remain In Place:	Roadway Width	Length		Type		
New Bridge:	Roadway Width	Length		Type		
Box Culvert:	Span	Rise	Length	Type		
Culvert:	Diameter	Length			Type	
Bridges and Culverts Sized	<input type="checkbox"/> Yes <input checked="" type="checkbox"/> N/A <input type="checkbox"/> Hydraulic Analysis Pending					
OTHER CONSTRUCTION FEATURES: 33' Wide concrete roadway w/curb & gutter						
ESTIMATED COST (In Thousands) *OPTIONAL	*COUNTY	*CITY	*STATE	*FEDERAL	*OTHER	TOTAL
		2000				2000
PROJECT LENGTH (Nearest Tenth, State Unit of Measure) 0.8 Miles				Project No.: M211(288)		
Signature: <i>Richard J. Boyer</i>				Title: City Engineer	Date: August 14, 2023	

BOARD OF PUBLIC ROADS CLASSIFICATIONS AND STANDARDS
FORM 7 ONE-AND SIX-YEAR PLAN
HIGHWAY OR STREET IMPROVEMENT PROJECT

County PLATTE	City: COLUMBUS	Village:				
Location Description: <p style="text-align: center;">Deerfield Park 2nd Add.</p>						
EXISTING SURFACE TYPE AND STRUCTURES: (Such As Dirt, Gravel, Asphalt, Concrete, Culvert Or Bridge) <p style="text-align: center;">Undeveloped</p>						
Average Daily Traffic: 2023 = <u>0</u> , 2043 = <u>200</u>		Classification Type: (As Shown On Functional Classification Map) <p style="text-align: center;">Local</p>				
Proposed Improvement						
Design Standard Number: <p style="text-align: center;">Municipal</p>		Surfacing Concrete	Thickness 6"	Width 33'		
<input checked="" type="checkbox"/> Grading	<input checked="" type="checkbox"/> Concrete	<input type="checkbox"/> Right Of Way	<input checked="" type="checkbox"/> Lighting			
<input type="checkbox"/> Aggregate	<input checked="" type="checkbox"/> Curb & Gutter	<input type="checkbox"/> Utility Adjustments			
<input type="checkbox"/> Armor Coat	<input checked="" type="checkbox"/> Drainage Structures	<input type="checkbox"/> Fencing			
<input type="checkbox"/> Asphalt	<input checked="" type="checkbox"/> Erosion Control	<input checked="" type="checkbox"/> Sidewalks			
Bridge To Remain In Place:	Roadway Width	Length		Type		
New Bridge:	Roadway Width	Length		Type		
Box Culvert:	Span	Rise	Length	Type		
Culvert:	Diameter	Length			Type	
Bridges and Culverts Sized	<input type="checkbox"/> Yes <input checked="" type="checkbox"/> N/A <input type="checkbox"/> Hydraulic Analysis Pending					
OTHER CONSTRUCTION FEATURES:						
.....						
.....						
.....						
.....						
ESTIMATED COST (In Thousands) *OPTIONAL	*COUNTY	*CITY	*STATE	*FEDERAL	*OTHER	TOTAL
					180	180
PROJECT LENGTH (Nearest Tenth, State Unit of Measure) 0.2 Miles			Project No.: M211(289)			
Signature: <i>Richard J. Boyer</i>			Title: City Engineer		Date: August 14, 2023	

BOARD OF PUBLIC ROADS CLASSIFICATIONS AND STANDARDS
FORM 7 ONE-AND SIX-YEAR PLAN
HIGHWAY OR STREET IMPROVEMENT PROJECT

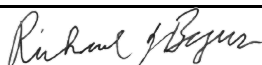
County PLATTE	City: COLUMBUS	Village:				
Location Description: <p style="text-align: center;">Ag Park Drainage 10th Ave. & 19th St. drainage to Lost Creek rail road bridge SE corner Christopher's Cove</p>						
EXISTING SURFACE TYPE AND STRUCTURES: (Such As Dirt, Gravel, Asphalt, Concrete, Culvert Or Bridge) <p style="text-align: center;">Open channel drainage</p>						
Average Daily Traffic: 2023 = <u>N/A</u> , 2043 = <u>N/A</u>	Classification Type: (As Shown On Functional Classification Map) N/A					
Proposed Improvement						
Design Standard Number:						
<input checked="" type="checkbox"/> Grading <input type="checkbox"/> Concrete <input type="checkbox"/> Right Of Way <input type="checkbox"/> Lighting <input type="checkbox"/> Aggregate <input type="checkbox"/> Curb & Gutter <input type="checkbox"/> Utility Adjustments <input type="checkbox"/> Armor Coat <input checked="" type="checkbox"/> Drainage Structures <input type="checkbox"/> Fencing <input type="checkbox"/> Asphalt <input checked="" type="checkbox"/> Erosion Control <input type="checkbox"/> Sidewalks						
Bridge To Remain In Place:	Roadway Width	Length	Type			
New Bridge:	Roadway Width	Length	Type			
Box Culvert:	Span	Rise	Length	Type		
Culvert:	Diameter 24" to twin 30"	Length	Type RCP			
Bridges and Culverts Sized	<input type="checkbox"/> Yes <input checked="" type="checkbox"/> N/A <input type="checkbox"/> Hydraulic Analysis Pending					
OTHER CONSTRUCTION FEATURES: <p style="text-align: center;">Clean out and upgrade drainage system and build retention structure</p>						
ESTIMATED COST (In Thousands) *OPTIONAL	*COUNTY	*CITY	*STATE	*FEDERAL	*OTHER	TOTAL
		250			750	1,000
PROJECT LENGTH (Nearest Tenth, State Unit of Measure) 0.9 Miles				Project No.: M211(290)		
Signature: 				Title: City Engineer		Date: August 14, 2023

BOARD OF PUBLIC ROADS CLASSIFICATIONS AND STANDARDS
FORM 7 ONE-AND SIX-YEAR PLAN
HIGHWAY OR STREET IMPROVEMENT PROJECT

County PLATTE	City: COLUMBUS	Village:				
Location Description: 21 st Avenue from 1 st to 3 rd Street; 21 st Avenue from 3 rd Street North ½ Block; <hr/> 4 Street from 20 th to 21 st Avenue; 4 th Street from 19 th to 20 th Avenue; <hr/> 3 rd Street from 19 th to 20 th Avenue <hr/>						
EXISTING SURFACE TYPE AND STRUCTURES: (Such As Dirt, Gravel, Asphalt, Concrete, Culvert Or Bridge) _____ Gravel _____ _____						
Average Daily Traffic: 2023 = <u>200</u> , 2043 = <u>300</u>	Classification Type: (As Shown On Functional Classification Map) _____ Local					
Proposed Improvement						
Design Standard Number: Municipal	Surfacing Concrete	Thickness 6"				
		Width 33'				
<input checked="" type="checkbox"/> Grading	<input checked="" type="checkbox"/> Concrete	<input type="checkbox"/> Right Of Way				
<input type="checkbox"/> Aggregate	<input checked="" type="checkbox"/> Curb & Gutter	<input checked="" type="checkbox"/> Utility Adjustments				
<input type="checkbox"/> Armor Coat	<input checked="" type="checkbox"/> Drainage Structures	<input type="checkbox"/> Fencing				
<input type="checkbox"/> Asphalt	<input checked="" type="checkbox"/> Erosion Control	<input type="checkbox"/> Sidewalks				
<input type="checkbox"/> Lighting						
Bridge To Remain In Place:	Roadway Width	Length	Type			
New Bridge:	Roadway Width	Length	Type			
Box Culvert:	Span	Rise	Length	Type		
Culvert:	Diameter	Length	Type			
Bridges and Culverts Sized	<input type="checkbox"/> Yes <input checked="" type="checkbox"/> N/A <input type="checkbox"/> Hydraulic Analysis Pending					
OTHER CONSTRUCTION FEATURES: _____ _____ 33' Concrete Paving and Storm Sewer _____ _____ _____						
ESTIMATED COST (In Thousands) *OPTIONAL	*COUNTY	*CITY	*STATE	*FEDERAL	*OTHER	TOTAL
		370				370
PROJECT LENGTH (Nearest Tenth, State Unit of Measure) 0.3 Miles				Project No.: M211(301)		
Signature: <i>Richard J. Bogus</i>				Title: City Engineer		Date: August 14, 2023

BOARD OF PUBLIC ROADS CLASSIFICATIONS AND STANDARDS
FORM 7 ONE-AND SIX-YEAR PLAN
HIGHWAY OR STREET IMPROVEMENT PROJECT

County PLATTE	City: COLUMBUS	Village:				
Location Description: <div style="text-align: center;">4 Street from 16th to 17th Avenue; 4 Street From 14th to 15th Avenue</div> <hr/> <div style="text-align: center;">3rd Street from 14th to 15th Avenue; 3rd Street from 13th to 14th Avenue</div> <hr/> <div style="text-align: center;">2nd Street from 14th to 15th Avenue; 2nd Street from 13th to 14th Avenue; 15th Avenue 3rd to 4th Street; 13th Avenue from 2nd to 3rd Street</div>						
EXISTING SURFACE TYPE AND STRUCTURES: (Such As Dirt, Gravel, Asphalt, Concrete, Culvert Or Bridge) <div style="text-align: center;">Gravel</div>						
Average Daily Traffic: 2023 = <u>200</u> , 2043 = <u>300</u>	Classification Type: (As Shown On Functional Classification Map) <div style="text-align: center;">Local</div>					
Proposed Improvement						
Design Standard Number: Municipal	Surfacing Concrete	Thickness 6"				
		Width 33'				
<input type="checkbox"/> Grading <input type="checkbox"/> Concrete <input type="checkbox"/> Right Of Way <input type="checkbox"/> Lighting <input type="checkbox"/> Aggregate <input type="checkbox"/> Curb & Gutter <input type="checkbox"/> Utility Adjustments <input type="checkbox"/> Armor Coat <input type="checkbox"/> Drainage Structures <input type="checkbox"/> Fencing <input type="checkbox"/> Asphalt <input type="checkbox"/> Erosion Control <input type="checkbox"/> Sidewalks						
Bridge To Remain In Place:	Roadway Width	Length	Type			
New Bridge:	Roadway Width	Length	Type			
Box Culvert:	Span	Rise	Length	Type		
Culvert:	Diameter	Length	Type			
Bridges and Culverts Sized	<input type="checkbox"/> Yes <input checked="" type="checkbox"/> N/A <input type="checkbox"/> Hydraulic Analysis Pending					
OTHER CONSTRUCTION FEATURES: <div style="text-align: center;">33' Concrete Paving and Storm Sewer</div>						
ESTIMATED COST (In Thousands) *OPTIONAL	*COUNTY	*CITY	*STATE	*FEDERAL	*OTHER	TOTAL
		525				525
PROJECT LENGTH (Nearest Tenth, State Unit of Measure) 0.4 Miles				Project No.: M211(302)		
Signature: 				Title: City Engineer		Date: August 14, 2023

BOARD OF PUBLIC ROADS CLASSIFICATIONS AND STANDARDS
FORM 7 ONE-AND SIX-YEAR PLAN
HIGHWAY OR STREET IMPROVEMENT PROJECT

County PLATTE	City: COLUMBUS	Village:
Location Description: <p style="text-align: center;">Power House Park Trail Phase 2</p> <p style="text-align: center;">North side of Lost Creek Parkway along Lost Creek Flood Control ditch from Wilderness Park Road to 3rd Ave.</p>		
EXISTING SURFACE TYPE AND STRUCTURES: (Such As Dirt, Gravel, Asphalt, Concrete, Culvert Or Bridge) <p style="text-align: center;">Undeveloped Land</p>		
Average Daily Traffic: 2023 = <u>0</u> , 2043 = <u>N/A</u>	Classification Type: (As Shown On Functional Classification Map) <p style="text-align: center;">N/A</p>	
Proposed Improvement		
Design Standard Number: Municipal	Surfacing Concrete	6" 10'
<input checked="" type="checkbox"/> Grading	<input checked="" type="checkbox"/> Concrete	<input type="checkbox"/> Right Of Way
<input type="checkbox"/> Aggregate	<input type="checkbox"/> Curb & Gutter	<input type="checkbox"/> Utility Adjustments
<input type="checkbox"/> Armor Coat	<input checked="" type="checkbox"/> Drainage Structures	<input type="checkbox"/> Fencing
<input type="checkbox"/> Asphalt	<input checked="" type="checkbox"/> Erosion Control	<input checked="" type="checkbox"/> Sidewalks
		<input type="checkbox"/> Lighting
		<input checked="" type="checkbox"/> Trail.....
	
	
Bridge To Remain In Place:	Roadway Width	Length
		Type
New Bridge:	Roadway Width	Length
		Type
Box Culvert:	Span	Rise
		Length
		Type
Culvert:	Diameter	Length
		Type
Bridges and Culverts Sized	<input type="checkbox"/> Yes <input checked="" type="checkbox"/> N/A <input type="checkbox"/> Hydraulic Analysis Pending	
OTHER CONSTRUCTION FEATURES: <p style="text-align: center;">Proposed: Nebraska Games & Park Recreational Trail Grant (50%)</p> <p style="text-align: center;">Proposed: Lower Loup NRD (15%)</p>		
ESTIMATED COST (In Thousands) *OPTIONAL	*COUNTY	*CITY
		175
		250
		75
		500
PROJECT LENGTH (Nearest Tenth, State Unit of Measure) 1.0 Miles	Project No.: M211(324)	
Signature: 	Title: City Engineer	Date: August 14, 2023

BOARD OF PUBLIC ROADS CLASSIFICATIONS AND STANDARDS
FORM 7 ONE-AND SIX-YEAR PLAN
HIGHWAY OR STREET IMPROVEMENT PROJECT

County PLATTE	City: COLUMBUS	Village:				
Location Description: <p style="text-align: center;">23 Street From 32 Avenue to East of East 11 Avenue</p>						
EXISTING SURFACE TYPE AND STRUCTURES: (Such As Dirt, Gravel, Asphalt, Concrete, Culvert Or Bridge) <p style="text-align: center;">Asphalt over Concrete</p>						
Average Daily Traffic: 2023 = <u>23,730</u> , 2043 = <u>40,000</u>		Classification Type: (As Shown On Functional Classification Map) <p style="text-align: center;">Expressway</p>				
Proposed Improvement						
Design Standard Number: Highway		Surfacing Concrete	Thickness TBD	Width 60' Plus		
<input checked="" type="checkbox"/> Grading	<input checked="" type="checkbox"/> Concrete	<input checked="" type="checkbox"/> Right Of Way	<input checked="" type="checkbox"/> Lighting			
<input type="checkbox"/> Aggregate	<input checked="" type="checkbox"/> Curb & Gutter	<input checked="" type="checkbox"/> Utility Adjustments	<input checked="" type="checkbox"/> Traffic Signals			
<input type="checkbox"/> Armor Coat	<input checked="" type="checkbox"/> Drainage Structures	<input type="checkbox"/> Fencing				
<input type="checkbox"/> Asphalt	<input checked="" type="checkbox"/> Erosion Control	<input checked="" type="checkbox"/> Sidewalks				
Bridge To Remain In Place:	Roadway Width	Length	Type			
New Bridge:	Roadway Width	Length	Type			
Box Culvert:	Span	Rise	Length	Type		
Culvert:	Diameter	Length	Type			
Bridges and Culverts Sized	<input type="checkbox"/> Yes <input checked="" type="checkbox"/> N/A <input type="checkbox"/> Hydraulic Analysis Pending					
OTHER CONSTRUCTION FEATURES: <p style="text-align: center;">NDOT Project – State and City funds. Sidewalk replacement, traffic signal replacement, Partial access elimination property acquisition</p>						
ESTIMATED COST (In Thousands) *OPTIONAL	*COUNTY	*CITY	*STATE	*FEDERAL	*OTHER	TOTAL
		10,800	21,200			32,000
PROJECT LENGTH (Nearest Tenth, State Unit of Measure) 2.7 Miles				Project No.: M211(325)		
Signature: 			Title: City Engineer		Date: August 14, 2023	

BOARD OF PUBLIC ROADS CLASSIFICATIONS AND STANDARDS
FORM 7 ONE-AND SIX-YEAR PLAN
HIGHWAY OR STREET IMPROVEMENT PROJECT

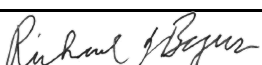
County PLATTE	City: COLUMBUS	Village:				
Location Description: <p style="text-align: center;">Riverside 3rd Addition</p>						
EXISTING SURFACE TYPE AND STRUCTURES: (Such As Dirt, Gravel, Asphalt, Concrete, Culvert Or Bridge) <p style="text-align: center;">Undeveloped Land</p>						
Average Daily Traffic: 2023 = <u>0</u> 0 2043 = <u>100</u>	Classification Type: (As Shown On Functional Classification Map) <p style="text-align: center;">Local</p>					
Proposed Improvement						
Design Standard Number: <p style="text-align: center;">Municipal</p>	Surfacing <p style="text-align: center;">Concrete</p>	Thickness <p style="text-align: center;">6"</p>				
		Width <p style="text-align: center;">33'</p>				
<input checked="" type="checkbox"/> Grading	<input checked="" type="checkbox"/> Concrete	<input type="checkbox"/> Right Of Way				
<input type="checkbox"/> Aggregate	<input checked="" type="checkbox"/> Curb & Gutter	<input type="checkbox"/> Utility Adjustments				
<input type="checkbox"/> Armor Coat	<input checked="" type="checkbox"/> Drainage Structures	<input type="checkbox"/> Fencing				
<input type="checkbox"/> Asphalt	<input type="checkbox"/> Erosion Control	<input type="checkbox"/> Sidewalks				
		<input checked="" type="checkbox"/> Lighting				
		<input type="checkbox"/>				
		<input type="checkbox"/>				
		<input type="checkbox"/>				
Bridge To Remain In Place:	Roadway Width	Length	Type			
New Bridge:	Roadway Width	Length	Type			
Box Culvert:	Span	Rise	Length	Type		
Culvert:	Diameter	Length	Type			
Bridges and Culverts Sized	<input type="checkbox"/> Yes <input checked="" type="checkbox"/> N/A <input type="checkbox"/> Hydraulic Analysis Pending					
OTHER CONSTRUCTION FEATURES: <p style="text-align: center;">Private development. Roads turned over to city.</p>						
ESTIMATED COST (In Thousands) *OPTIONAL	*COUNTY	*CITY	*STATE	*FEDERAL	*OTHER	TOTAL
					125	125
PROJECT LENGTH (Nearest Tenth, State Unit of Measure) <p style="text-align: center;">0.1 Miles</p>				Project No.: <p style="text-align: center;">M211(346)</p>		
Signature: 				Title: City Engineer		Date: August 14, 2023

BOARD OF PUBLIC ROADS CLASSIFICATIONS AND STANDARDS
FORM 7 ONE-AND SIX-YEAR PLAN
HIGHWAY OR STREET IMPROVEMENT PROJECT

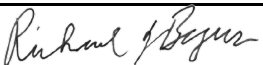
County PLATTE	City: COLUMBUS	Village:				
Location Description: <p style="text-align: center;">23rd Street / Shady Lake Road from 54th Avenue to West Corporate Limits</p> <p style="text-align: center;">SID #188</p>						
EXISTING SURFACE TYPE AND STRUCTURES: (Such As Dirt, Gravel, Asphalt, Concrete, Culvert Or Bridge) <p style="text-align: center;">24' Rural Asphalt</p>						
Average Daily Traffic: 2023 = <u>1,360</u> 0 2043 = <u>2,500</u>		Classification Type: (As Shown On Functional Classification Map) <p style="text-align: center;">Arterial</p>				
Proposed Improvement						
Design Standard Number: Municipal		Surfacing Concrete	Thickness 9"	Width 41'		
<input checked="" type="checkbox"/> Grading	<input checked="" type="checkbox"/> Concrete	<input type="checkbox"/> Right Of Way	<input checked="" type="checkbox"/> Lighting			
<input type="checkbox"/> Aggregate	<input checked="" type="checkbox"/> Curb & Gutter	<input type="checkbox"/> Utility Adjustments	<input type="checkbox"/>			
<input type="checkbox"/> Armor Coat	<input checked="" type="checkbox"/> Drainage Structures	<input type="checkbox"/> Fencing				
<input type="checkbox"/> Asphalt	<input type="checkbox"/> Erosion Control	<input checked="" type="checkbox"/> Sidewalks				
Bridge To Remain In Place:	Roadway Width	Length	Type			
New Bridge:	Roadway Width	Length	Type			
Box Culvert:	Span	Rise	Length	Type		
Culvert:	Diameter	Length	Type			
Bridges and Culverts Sized	<input type="checkbox"/> Yes <input checked="" type="checkbox"/> N/A <input type="checkbox"/> Hydraulic Analysis Pending					
OTHER CONSTRUCTION FEATURES: <p style="text-align: center;">Federal Funds Purchase Program Assessments</p>						
ESTIMATED COST (In Thousands) *OPTIONAL	*COUNTY	*CITY	*STATE	*FEDERAL	*OTHER	TOTAL
		3,450				3,450
PROJECT LENGTH (Nearest Tenth, State Unit of Measure) 0.6 Miles				Project No.:M211(352)		
Signature: 			Title: City Engineer		Date: August 14, 2023	

BOARD OF PUBLIC ROADS CLASSIFICATIONS AND STANDARDS
FORM 7 ONE-AND SIX-YEAR PLAN
HIGHWAY OR STREET IMPROVEMENT PROJECT

County PLATTE	City: COLUMBUS	Village:				
Location Description: <p style="text-align: center;">Downtown Evaluation UPRR Separation Study</p>						
EXISTING SURFACE TYPE AND STRUCTURES: (Such As Dirt, Gravel, Asphalt, Concrete, Culvert Or Bridge) <p style="text-align: center;">At grade crossings at 23rd Avenue and 26th Avenue</p>						
Average Daily Traffic: 2023 = <u>NA</u> 0 2043 = <u>NA</u>	Classification Type: (As Shown On Functional Classification Map)					
Proposed Improvement						
Design Standard Number: Municipal	Surfacing Concrete	Thickness 6"				
		Width 33'				
<input type="checkbox"/> Grading <input type="checkbox"/> Concrete <input type="checkbox"/> Right Of Way <input type="checkbox"/> Lighting <input type="checkbox"/> Aggregate <input type="checkbox"/> Curb & Gutter <input type="checkbox"/> Utility Adjustments <input checked="" type="checkbox"/> Study <input type="checkbox"/> Armor Coat <input type="checkbox"/> Drainage Structures <input type="checkbox"/> Fencing <input type="checkbox"/> Asphalt <input type="checkbox"/> Erosion Control <input type="checkbox"/> Sidewalks						
Bridge To Remain In Place:	Roadway Width	Length	Type			
New Bridge:	Roadway Width	Length	Type			
Box Culvert:	Span	Rise	Length	Type		
Culvert:	Diameter	Length	Type			
Bridges and Culverts Sized	<input type="checkbox"/> Yes <input checked="" type="checkbox"/> N/A <input type="checkbox"/> Hydraulic Analysis Pending					
OTHER CONSTRUCTION FEATURES: <p style="text-align: center;">UPRR Tracks</p>						
ESTIMATED COST (In Thousands) *OPTIONAL	*COUNTY	*CITY	*STATE	*FEDERAL	*OTHER	TOTAL
		275				275
PROJECT LENGTH (Nearest Tenth, State Unit of Measure)				Project No.:		
				M211(355)		
Signature: <i>Richard J. Boyer</i>				Title: City Engineer		Date: August 14, 2023

BOARD OF PUBLIC ROADS CLASSIFICATIONS AND STANDARDS
FORM 7 ONE-AND SIX-YEAR PLAN
HIGHWAY OR STREET IMPROVEMENT PROJECT

County PLATTE	City: COLUMBUS	Village:				
Location Description: <p style="text-align: center;">63rd Avenue Howard Boulevard to Lost Creek Parkway (Private Development)</p>						
EXISTING SURFACE TYPE AND STRUCTURES: (Such As Dirt, Gravel, Asphalt, Concrete, Culvert Or Bridge) <p style="text-align: center;">Gravel</p>						
Average Daily Traffic: 2023 = _____ 0 2043 = _____		Classification Type: (As Shown On Functional Classification Map) <p style="text-align: center;">Collector</p>				
Proposed Improvement						
Design Standard Number: <p style="text-align: center;">Municipal</p>		Surfacing <p style="text-align: center;">Concrete</p>	Thickness <p style="text-align: center;">9"</p>	Width <p style="text-align: center;">41'</p>		
<input checked="" type="checkbox"/> Grading	<input checked="" type="checkbox"/> Concrete	<input type="checkbox"/> Right Of Way	<input checked="" type="checkbox"/> Lighting			
<input type="checkbox"/> Aggregate	<input checked="" type="checkbox"/> Curb & Gutter	<input checked="" type="checkbox"/> Utility Adjustments		<input type="checkbox"/> Study		
<input type="checkbox"/> Armor Coat	<input checked="" type="checkbox"/> Drainage Structures	<input type="checkbox"/> Fencing				
<input type="checkbox"/> Asphalt	<input type="checkbox"/> Erosion Control	<input checked="" type="checkbox"/> Sidewalks				
Bridge To Remain In Place:	Roadway Width	Length		Type		
New Bridge:	Roadway Width	Length		Type		
Box Culvert:	Span	Rise	Length		Type	
Culvert:	Diameter	Length			Type	
Bridges and Culverts Sized	<input type="checkbox"/> Yes <input checked="" type="checkbox"/> N/A <input type="checkbox"/> Hydraulic Analysis Pending					
OTHER CONSTRUCTION FEATURES:						
ESTIMATED COST (In Thousands) *OPTIONAL	*COUNTY	*CITY	*STATE	*FEDERAL	*OTHER	TOTAL
					2,500	2,500
PROJECT LENGTH (Nearest Tenth, State Unit of Measure) <p style="text-align: center;">0.5 Miles</p>				Project No.: <p style="text-align: center;">M211(357)</p>		
Signature: <i>Richard J. Begus</i>			Title: City Engineer		Date: August 14, 2023	

BOARD OF PUBLIC ROADS CLASSIFICATIONS AND STANDARDS
FORM 7 ONE-AND SIX-YEAR PLAN
HIGHWAY OR STREET IMPROVEMENT PROJECT

County PLATTE	City: COLUMBUS	Village:				
Location Description: <p style="text-align: center;">East Park / 17th Street from 16th to 18th Avenues</p> <p style="text-align: center;">Storm Sewer</p>						
EXISTING SURFACE TYPE AND STRUCTURES: (Such As Dirt, Gravel, Asphalt, Concrete, Culvert Or Bridge) <p style="text-align: center;">Concrete</p>						
Average Daily Traffic: 2023 = <u>NA</u> 0 2043 = <u>NA</u>	Classification Type: (As Shown On Functional Classification Map) <p style="text-align: center;">Collector</p>					
Proposed Improvement						
Design Standard Number: Municipal	Surfacing	Thickness				
		Width				
<input type="checkbox"/> Grading <input type="checkbox"/> Concrete <input type="checkbox"/> Right Of Way <input type="checkbox"/> Lighting <input type="checkbox"/> Aggregate <input type="checkbox"/> Curb & Gutter <input type="checkbox"/> Utility Adjustments <input type="checkbox"/> Study <input type="checkbox"/> Armor Coat <input checked="" type="checkbox"/> Drainage Structures <input type="checkbox"/> Fencing <input type="checkbox"/> Asphalt <input type="checkbox"/> Erosion Control <input type="checkbox"/> Sidewalks						
Bridge To Remain In Place:	Roadway Width	Length	Type			
New Bridge:	Roadway Width	Length	Type			
Box Culvert:	Span	Rise	Length	Type		
Culvert:	Diameter	Length	Type			
Bridges and Culverts Sized	<input type="checkbox"/> Yes <input checked="" type="checkbox"/> N/A <input type="checkbox"/> Hydraulic Analysis Pending					
OTHER CONSTRUCTION FEATURES: <p style="text-align: center;">Storm Sewer improvements from East Park Rain Garden to 17th Street to 16th Avenue</p>						
ESTIMATED COST (In Thousands) *OPTIONAL	*COUNTY	*CITY	*STATE	*FEDERAL	*OTHER	TOTAL
		350				350
PROJECT LENGTH (Nearest Tenth, State Unit of Measure) 0.2 Miles				Project No.: M211(358)		
Signature: <i>Richard J. Boyer</i>				Title: City Engineer		Date: August 14, 2023

BOARD OF PUBLIC ROADS CLASSIFICATIONS AND STANDARDS
FORM 7 ONE-AND SIX-YEAR PLAN
HIGHWAY OR STREET IMPROVEMENT PROJECT

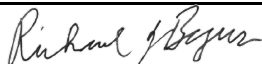
County PLATTE	City: COLUMBUS	Village:				
Location Description: <p style="text-align: center;">Signal Upgrades 27th Street & 33rd Avenue</p>						
EXISTING SURFACE TYPE AND STRUCTURES: (Such As Dirt, Gravel, Asphalt, Concrete, Culvert Or Bridge)						
Average Daily Traffic: 2023 = <u>9,000</u> 0 2043 = <u>11,500</u>	Classification Type: (As Shown On Functional Classification Map) <p style="text-align: center;">Arterial</p>					
Proposed Improvement						
Design Standard Number: Municipal	Surfacing	Thickness				
<input type="checkbox"/> Grading <input type="checkbox"/> Concrete <input type="checkbox"/> Right Of Way <input type="checkbox"/> Lighting <input type="checkbox"/> Aggregate <input type="checkbox"/> Curb & Gutter <input type="checkbox"/> Utility Adjustments <input type="checkbox"/> Study <input type="checkbox"/> Armor Coat <input type="checkbox"/> Drainage Structures <input type="checkbox"/> Fencing <input checked="" type="checkbox"/> Traffic Signal <input type="checkbox"/> Asphalt <input type="checkbox"/> Erosion Control <input type="checkbox"/> Sidewalks						
Bridge To Remain In Place:	Roadway Width	Length	Type			
New Bridge:	Roadway Width	Length	Type			
Box Culvert:	Span	Rise	Length	Type		
Culvert:	Diameter	Length	Type			
Bridges and Culverts Sized	<input type="checkbox"/> Yes <input checked="" type="checkbox"/> N/A <input type="checkbox"/> Hydraulic Analysis Pending					
OTHER CONSTRUCTION FEATURES: <p style="text-align: center;">Existing Signal Upgrades</p>						
ESTIMATED COST (In Thousands) *OPTIONAL	*COUNTY	*CITY	*STATE	*FEDERAL	*OTHER	TOTAL
		100				100
PROJECT LENGTH (Nearest Tenth, State Unit of Measure)				Project No.:		
				M211(359)		
Signature: 				Title: City Engineer		Date: August 14, 2023

BOARD OF PUBLIC ROADS CLASSIFICATIONS AND STANDARDS
FORM 7 ONE-AND SIX-YEAR PLAN
HIGHWAY OR STREET IMPROVEMENT PROJECT

County PLATTE	City: COLUMBUS	Village:
Location Description: <p style="text-align: center;">Signal Upgrades</p> <p style="text-align: center;">Wilderness Road and Lost Creek Parkway</p>		
EXISTING SURFACE TYPE AND STRUCTURES: (Such As Dirt, Gravel, Asphalt, Concrete, Culvert Or Bridge)		
Average Daily Traffic: 2023 = <u>7,000</u> 0 2043 = <u>10,200</u>		Classification Type: (As Shown On Functional Classification Map) Major Arterial
Proposed Improvement		
Design Standard Number: Municipal	Surfacing	Thickness
<input type="checkbox"/> Grading <input type="checkbox"/> Concrete <input type="checkbox"/> Right Of Way <input type="checkbox"/> Lighting <input type="checkbox"/> Aggregate <input type="checkbox"/> Curb & Gutter <input type="checkbox"/> Utility Adjustments <input type="checkbox"/> Study <input type="checkbox"/> Armor Coat <input type="checkbox"/> Drainage Structures <input type="checkbox"/> Fencing <input checked="" type="checkbox"/> Traffic Signal <input type="checkbox"/> Asphalt <input type="checkbox"/> Erosion Control <input type="checkbox"/> Sidewalks		
Bridge To Remain In Place:	Roadway Width	Length
New Bridge:	Roadway Width	Length
Box Culvert:	Span	Rise
Culvert:	Diameter	Length
Bridges and Culverts Sized	<input type="checkbox"/> Yes <input checked="" type="checkbox"/> N/A <input type="checkbox"/> Hydraulic Analysis Pending	
OTHER CONSTRUCTION FEATURES: <p style="text-align: center;">Existing Signal Upgrades</p>		
ESTIMATED COST (In Thousands) *OPTIONAL	*COUNTY	*CITY
		100
PROJECT LENGTH (Nearest Tenth, State Unit of Measure)		Project No.: M211(360)
Signature: 	Title: City Engineer	Date: August 14, 2023

BOARD OF PUBLIC ROADS CLASSIFICATIONS AND STANDARDS
FORM 7 ONE-AND SIX-YEAR PLAN
HIGHWAY OR STREET IMPROVEMENT PROJECT

County PLATTE	City: COLUMBUS	Village:				
Location Description: <p style="text-align: center;">Private Development – Centennial Park 8th Addition</p> <p style="text-align: center;">2nd Street from 3rd to 7th Avenues; 5th Avenue from 2nd Street north and south 200' and</p> <p style="text-align: center;">6th Avenue from 2nd Street south 200'</p>						
EXISTING SURFACE TYPE AND STRUCTURES: (Such As Dirt, Gravel, Asphalt, Concrete, Culvert Or Bridge) <p style="text-align: center;">Undeveloped Land</p>						
Average Daily Traffic: 2023 = <u>200</u> 0 2043 = <u>400</u>	Classification Type: (As Shown On Functional Classification Map) <p style="text-align: center;">Local</p>					
Proposed Improvement						
Design Standard Number: Municipal	Surfacing Concrete	Thickness 6"				
		Width 33'				
<input checked="" type="checkbox"/> Grading <input checked="" type="checkbox"/> Concrete <input type="checkbox"/> Right Of Way <input checked="" type="checkbox"/> Lighting <input type="checkbox"/> Aggregate <input checked="" type="checkbox"/> Curb & Gutter <input type="checkbox"/> Utility Adjustments <input type="checkbox"/> Study <input type="checkbox"/> Armor Coat <input checked="" type="checkbox"/> Drainage Structures <input type="checkbox"/> Fencing <input type="checkbox"/> Asphalt <input type="checkbox"/> Erosion Control <input checked="" type="checkbox"/> Sidewalks						
Bridge To Remain In Place:	Roadway Width	Length	Type			
New Bridge:	Roadway Width	Length	Type			
Box Culvert:	Span	Rise	Length	Type		
Culvert:	Diameter	Length	Type			
Bridges and Culverts Sized	<input type="checkbox"/> Yes <input checked="" type="checkbox"/> N/A <input type="checkbox"/> Hydraulic Analysis Pending					
OTHER CONSTRUCTION FEATURES: 						
ESTIMATED COST (In Thousands) *OPTIONAL	*COUNTY	*CITY	*STATE	*FEDERAL	*OTHER	TOTAL
					350	350
PROJECT LENGTH (Nearest Tenth, State Unit of Measure) 0.4 Miles				Project No.: M211(362)		
Signature: <i>Richard J. Boyer</i>				Title: City Engineer		Date: August 14, 2023

BOARD OF PUBLIC ROADS CLASSIFICATIONS AND STANDARDS
FORM 7 ONE-AND SIX-YEAR PLAN
HIGHWAY OR STREET IMPROVEMENT PROJECT

County PLATTE	City: COLUMBUS	Village:
Location Description: <p style="text-align: center;">Park Place 10th Addition, Private Developer Subdivision</p>		
EXISTING SURFACE TYPE AND STRUCTURES: (Such As Dirt, Gravel, Asphalt, Concrete, Culvert Or Bridge)		
Average Daily Traffic: 2023 = <u> 0 </u> 2043 = <u> 150 </u>	Classification Type: (As Shown On Functional Classification Map) <p style="text-align: center;">Arterial</p>	
Proposed Improvement		
Design Standard Number: <p style="text-align: center;">Municipal</p>	Surfacing <p style="text-align: center;">Concrete</p>	Thickness <p style="text-align: center;">9"</p>
Width <p style="text-align: right;">41'</p>		
<input checked="" type="checkbox"/> Grading	<input checked="" type="checkbox"/> Concrete	<input type="checkbox"/> Right Of Way
<input type="checkbox"/> Aggregate	<input checked="" type="checkbox"/> Curb & Gutter	<input type="checkbox"/> Utility Adjustments
<input type="checkbox"/> Armor Coat	<input checked="" type="checkbox"/> Drainage Structures	<input type="checkbox"/> Fencing
<input type="checkbox"/> Asphalt	<input checked="" type="checkbox"/> Erosion Control	<input checked="" type="checkbox"/> Sidewalks
<input checked="" type="checkbox"/> Lighting	<input type="checkbox"/> Trails	
Bridge To Remain In Place:	Roadway Width	Length
		Type
New Bridge:	Roadway Width	Length
		Type
Box Culvert:	Span	Rise
		Length
		Type
Culvert:	Diameter	Length
		Type
Bridges and Culverts Sized	<input type="checkbox"/> Yes <input checked="" type="checkbox"/> N/A <input type="checkbox"/> Hydraulic Analysis Pending	
OTHER CONSTRUCTION FEATURES:		
ESTIMATED COST		
(In Thousands)	*COUNTY	*CITY
*OPTIONAL		
	*STATE	*FEDERAL
	*OTHER	TOTAL
	225	225
PROJECT LENGTH (Nearest Tenth, State Unit of Measure) <p style="text-align: center;">0.2 Miles</p>	Project No.: <p style="text-align: center;">M211(366)</p>	
Signature: 	Title: City Engineer	Date: August 14, 2023

7.A.1. Resolution No. R23-117 adopting One and Six Year Plan.

RESOLUTION NO. R23-117

A RESOLUTION OF THE MAYOR AND COUNCIL OF THE CITY OF COLUMBUS, NEBRASKA, ADOPTING A ONE AND SIX YEAR PLAN FOR HIGHWAY, ROAD, AND STREET IMPROVEMENTS FOR THE CITY OF COLUMBUS, NEBRASKA.

WHEREAS, the city street superintendent has prepared and submitted to the mayor and council of the City of Columbus, Nebraska, a One and Six Year Plan for Highway, Road, and Street Improvements (One and Six Year Plan); and

WHEREAS, Notice of Public Hearing on the proposed One and Six Year Plan was published in the Columbus Telegram, a newspaper published and of general circulation in the City of Columbus, on August 25, 2023, proof of publication of which is on file in the office of the city clerk; and

WHEREAS, Notice of Public Hearing on the proposed One and Six Year Plan was posted at the Platte County Courthouse, Columbus Public Library, and Columbus Community Building in the city of Columbus on August 25, 2023, affidavit of posting of which is on file in the office of the city engineer; and

WHEREAS, such public hearing was held on the aforesaid One and Six Year Plan in the Council Chambers at 6:00 p.m., on September 5, 2023, at which time the mayor and council heard all persons in favor of, opposed to, and explained any questions asked thereon, and at the conclusion thereof, the mayor and council found and determined that the One and Six Year Plan for street improvements for the City of Columbus should be adopted without amendment.

NOW, THEREFORE, BE IT RESOLVED BY THE MAYOR AND COUNCIL OF THE CITY OF COLUMBUS, NEBRASKA, that the One and Six Year Plan for the City of Columbus, Nebraska, be adopted.

BE IT FURTHER RESOLVED that a copy of this resolution, a copy of the affidavit of publication of notice of public hearing, and a copy of the One and Six Year Plan be submitted to the State of Nebraska, Department of Transportation.

INTRODUCED BY COUNCIL MEMBER _____

PASSED AND ADOPTED THIS ____ DAY OF _____, 2023.

MAYOR

ATTEST:

CITY CLERK

APPROVED AS TO FORM:

CITY ATTORNEY

The City of **Columbus**

MEMORANDUM

DATE: August 10, 2023
FROM: Richard J. Bogus, P.E., City Engineer
TO: Tara Vasicek, City Administrator
RE: Nebraska Board of Public Roads Classifications and Standards
2023-2024 Fiscal Year One and Six Year Road Plan

RECOMMENDATION:

I recommend approval of the 2023-2024 fiscal year One and Six Year Road Plan and related forms.

DISCUSSION:

The 2024 One Year Plan (Form 8) consists of the following. Refer to the One and Six Year Road Plan map and Form 7s for locations and details.

Total number of projects: 10
City projects: 7
Private development projects: 3
Projects completed: 7
Projects continued: 9

Total One Year Plan estimated cost: \$39.7 million
Public projects: \$38.9 million
Private projects: \$0.7 million

The 2024 Six Year Plan (Form 9) consists of the following. Refer to the One and Six Year Road Plan map and Form 7s for locations and details.

Total number of additional projects from the One Year Plan: 23
Total estimated additional project costs from the One Year Plan: \$27.4 million

The 2023 One & Six Year Road Plan was amended with one project (Form 10)

Maintenance defined projects are not included by rule in the One and Six Year Road Plans.

FISCAL IMPACT:

The City has included its portion of the costs in the 2022-2023 and/or 2023-2024 budgets

ALTERNATIVE:

Annual 1&6 Year Road Plan certification is required to obtain Highway-user revenue.

SIGNATURE:

By: Richard J. Bogus

Approved By: [Signature]

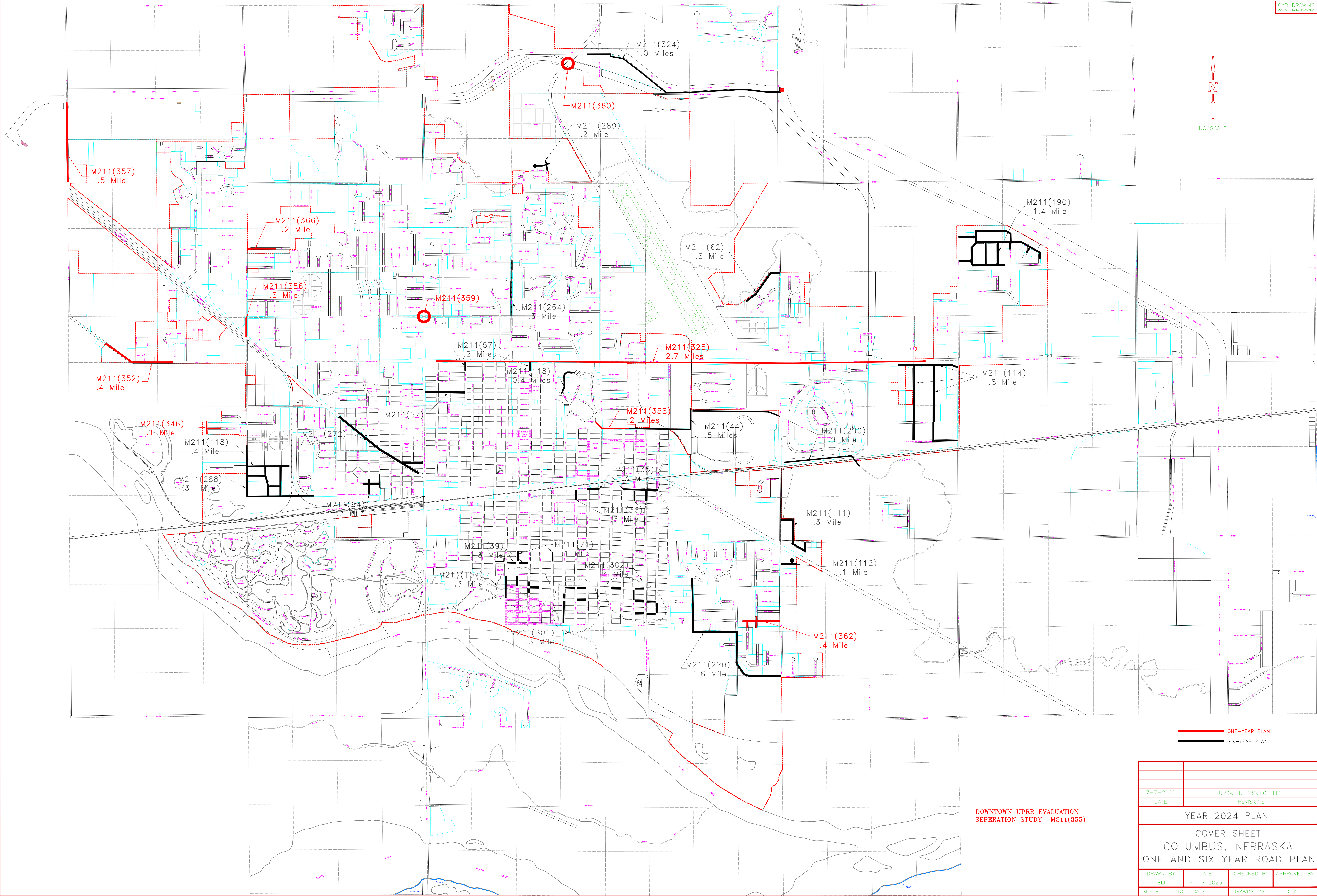
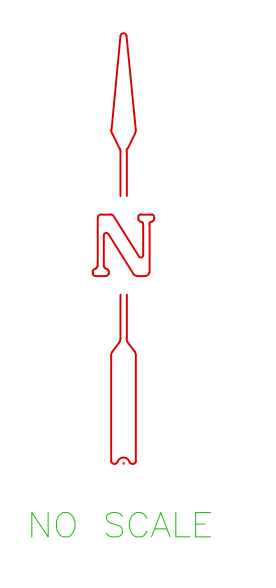

— ONE-YEAR PLAN
— SIX-YEAR PLAN

DOWNTOWN UPRR EVALUATION
SEPERATION STUDY M211(355)

7-7-2022	UPDATED PROJECT LIST		
DATE	REVISIONS		
YEAR 2024 PLAN			
COVER SHEET COLUMBUS, NEBRASKA ONE AND SIX YEAR ROAD PLAN			
DRAWN BY BLI	DATE 8-10-2023	CHECKED BY	APPROVED BY
SCALE: NO SCALE	DRAWING NO.	CITY	

Board of Public Roads Classifications and Standards
Form 8 Summary of One-Year Plan

Year Ending: December 31, 2024

Sheet 1 of 1

County: PLATTE		City: COLUMBUS		Village:	
PRIORITY NUMBER	PROJECT NUMBER	LENGTH (Nearest Tenth)	UNIT OF MEASURE	ESTIMATED COST (Thousands)	REMARKS
1	M211(325)	2.7	Miles	32,000	23 St. 32 Ave. to E 11 Ave
2	M211(355)	-	-	275	Downtown Eval UPRR Sep Study
3	M211 (357)	0.5	Miles	2,500	63 Ave, Howard Blvd. to Lost Creek Pkwy
4	M211 (358)	0.2	Miles	350	Storm Sewer Const. 17 St 16-18 Ave
5	M211 (359)	-	-	100	27 St & 33 Ave Light Signal Upgrade
6	M211 (360)	-	-	200	LCP & Wilderness Rd Signal Upgrades
7	M211 (352)	0.4	Miles	3,450	23/Shady Lake, 54 Ave to W Corn Limits
8	M211(366)	0.2	Miles	225	Park Place 10 th Addition
9	M211 (362)	0.4	Miles	350	Centennial Park 8th Add
10	M211 (346)	0.1	Miles	125	Riverside 3 rd Addition
Signature: <i>Richard J. Boyer</i>		Title: City Engineer		Date: August 14, 2023	

Board of Public Roads Classifications and Standards
Form 9 Summary of Six-Year Plan

Six-Year Period Ending: December 31, 2029

Sheet 1 of 2

County: PLATTE		City: COLUMBUS		Village:	
PRIORITY NUMBER	PROJECT NUMBER	LENGTH (Nearest Tenth)	UNIT OF MEASURE	ESTIMATED COST (Thousands)	REMARKS
1	M211 (325)	2.7	Miles	32,000	23 St. 32 Ave. to E 11 Ave Habitat Drive
2	M211(355)			275	Downtown Eval. UPRR Sen Study
3	M211 (357)	0.5	Miles	2,500	63 Ave howard Blvd to Lost Creek Pkwy
4	M211 (358)	0.2	Miles	350	East Park/17 St. from 16-18 Ave S
5	M211 (359)	-	-	100	Signal UG 27 St - 33 Ave
6	M211 (360)	-	-	200	Signal UG Wilderness & I CP
7	M211 (352)	0.4	Miles	2,000	23 Ave/Shady Lake 54 Ave/WCI
8	M211 (366)	0.2	Miles	225	Park Place 10 th Addition
9	M211 (362)	0.4	Miles	350	Centennial Pak 8th Addition
10	M211(346)	0.1	Miles	125	Riverside 3 rd Addition
11	M211(290)	-	-	1,000	Ag Park Drainage
12	M211(272)	1.0	Miles	2,700	Howard Blvd. 33 Ave to 23 St
13	M211(220)	1.6	Miles	2,500	10 Ave Lovers Lane to 5 St
14	M211(289)	0.5	Miles	180	Deerfield Park 2nd Addition
15	M211(44)	-	-	10,300	Storm Sewer East Park/11 St
16	M211(288)	0.3	Miles	2,000	48 Ave. Park to 11 St 11 St 41-48 Ave
17	M211(39)	0.3	Miles	110	Curb & Gutter 6 St 24-26 Ave
18	M211(36)	0.3	Miles	290	14, 15, & 20 Ave between 11 & 12 St
19	M211(264)	0.3	Miles	820	26 Ave from 27-32 St
20	M211(112)	0.3	Miles	260	Crumley Subdivision
21	M211(114)	0.8	Miles	1,100	Sand Subdivision
22	M211(57)			110	Storm Sewer Impr 30 Ave 22-23 St
23	M211(190)	1.4	Miles	2,500	Johannes Addition
24	M211(64)	0.2	Miles	250	Oida Addition
25	M211 (111)	0.3	Miles	360	Gates 1&2 Subdivisions
Signature: 			Title: City Engineer		Date: August 14, 2023

Board Of Public Roads Classifications And Standards
FORM 10 Notification of Revision of One-Year Plan

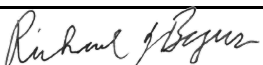
County PLATTE	City: COLUMBUS	Village:
REASON FOR REVISION: <p style="text-align: center;">Private developer subdivision</p>		
LOCATION DESCRIPTION <p style="text-align: center;">Park Place 9th Addition, private developer subdivision</p>		
EXISTING SURFACE TYPE AND STRUCTURES: (Such As Dirt, Gravel, Asphalt, Concrete, Culvert Or Bridge) <p style="text-align: center;">Undeveloped Land</p>		
Average Daily Traffic: 2023 = <u>0</u> , 2043 = <u>150</u>	Classification Type: (As Shown On Functional Classification Map) <p style="text-align: center;">Local</p>	
Proposed Improvement		
Design Standard Number: Municipal	Surfacing	Thickness 6" Width 33'
<input checked="" type="checkbox"/> Grading	<input checked="" type="checkbox"/> Concrete	<input type="checkbox"/> Right Of Way
<input type="checkbox"/> Aggregate	<input checked="" type="checkbox"/> Curb & Gutter	<input checked="" type="checkbox"/> Lighting
<input type="checkbox"/> Armor Coat	<input checked="" type="checkbox"/> Drainage Structures	<input type="checkbox"/> Utility Adjustments
<input type="checkbox"/> Asphalt	<input type="checkbox"/> Erosion Control	<input checked="" type="checkbox"/> Sidewalks
Bridge To Remain In Place:	Roadway Width	Length Type
New Bridge:	Roadway Width	Length Type
Box Culvert:	Span	Rise Length Type
Culvert:	Diameter	Length Type
Bridges and Culverts Sized	<input type="checkbox"/> Yes <input checked="" type="checkbox"/> N/A <input type="checkbox"/> Hydraulic Analysis Pending	
OTHER CONSTRUCTION FEATURES: <p style="text-align: center;">Private development. Roads turned over to city.</p>		
ESTIMATED COST (In Thousands) *OPTIONAL	*COUNTY	*CITY
		*STATE
		*FEDERAL
		*OTHER
		200
		TOTAL
		200
PROJECT LENGTH (Nearest Tenth, State Unit of Measure) 0.1 Miles		Project No.: M211 (365)
Signature: 	Title: City Engineer	Date: August 14, 2023

Board of Public Roads Classifications and Standards
Form 11 Report of Previous Year
Highway or Street Improvement

Year Ending: December 31, 2023

Sheet 1 of 1

County: PLATTE		City: COLUMBUS			Village:	
PROJECT NUMBER	LENGTH (Nearest Tenth)	UNIT OF MEASURE	PROJECTED COST (Thousands)	CONTRACT PROJECT	OWN FORCES	DATE COMPLETED (Actual or Estimated)
M211(257)	0.8	Miles	3,600	X		5/23
M211 (273)	0.6	Miles	2,400	X		8/23
M211(316)	1.0	Miles	500	X		6/23
M211 (325)	2.7	Miles	32,000	X		Continues
M211 (346)	0.1	Miles	125	X		Continues
M211 (352)	0.4	Miles	3,450	X		Continues
M211 (353)	0.5	Miles	2,650	X		8/23
M211 (355)	-	-	275	X		Continues
M211 (356)	0.3	Miles	950	X		8/23
M211 (357)	0.5	Miles	2,500	X		Continues
M211 (358)	0.2	Miles	350	X		Continues
M211 (359)	-	-		X		Continues
M211 (360)	-	-		X		Continues
M211 (361)	0.1	Miles		X		7/23
M211 (362)	0.4	Miles		X		Continues
M211 (363)	0.3	Miles			X	7/23
Signature: <i>Richard J. Boyer</i>		Title: City Engineer			Date: August 14, 2023	

BOARD OF PUBLIC ROADS CLASSIFICATIONS AND STANDARDS
FORM 7 ONE-AND SIX-YEAR PLAN
HIGHWAY OR STREET IMPROVEMENT PROJECT

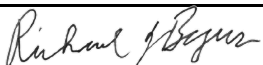
County PLATTE	City: COLUMBUS	Village:				
Location Description: <div style="text-align: center;">12th Street from 12th Avenue to 16th Avenue</div> <hr/> <div style="text-align: center;">12th Street from 18th Avenue to 19th Avenue</div> <hr/>						
EXISTING SURFACE TYPE AND STRUCTURES: (Such As Dirt, Gravel, Asphalt, Concrete, Culvert Or Bridge) <div style="text-align: center;">Gravel</div> <hr/>						
Average Daily Traffic: 2023 = <u>200</u> , 2043 = <u>400</u>	Classification Type: (As Shown On Functional Classification Map) Local					
Proposed Improvement						
Design Standard Number: Municipal	Surfacing Concrete	Thickness 6"				
		Width 33'				
<input checked="" type="checkbox"/> Grading <input checked="" type="checkbox"/> Concrete <input type="checkbox"/> Right Of Way <input type="checkbox"/> Lighting <input type="checkbox"/> Aggregate <input checked="" type="checkbox"/> Curb & Gutter <input checked="" type="checkbox"/> Utility Adjustments <input type="checkbox"/> Armor Coat <input checked="" type="checkbox"/> Drainage Structures <input type="checkbox"/> Fencing <input type="checkbox"/> Asphalt <input checked="" type="checkbox"/> Erosion Control <input checked="" type="checkbox"/> Sidewalks						
Bridge To Remain In Place:	Roadway Width	Length	Type			
New Bridge:	Roadway Width	Length	Type			
Box Culvert:	Span	Rise	Length	Type		
Culvert:	Diameter	Length	Type			
Bridges and Culverts Sized	<input type="checkbox"/> Yes <input checked="" type="checkbox"/> N/A <input type="checkbox"/> Hydraulic Analysis Pending					
OTHER CONSTRUCTION FEATURES: <div style="text-align: center;">Paving over existing Gravel Roadway w/Misc. grading</div> <hr/>						
ESTIMATED COST (In Thousands) *OPTIONAL	*COUNTY	*CITY	*STATE	*FEDERAL	*OTHER	TOTAL
		290				290
PROJECT LENGTH (Nearest Tenth, State Unit of Measure) 0.3 Miles				Project No.: M211(35)		
Signature: 				Title: City Engineer		Date: August 14, 2023

BOARD OF PUBLIC ROADS CLASSIFICATIONS AND STANDARDS
FORM 7 ONE-AND SIX-YEAR PLAN
HIGHWAY OR STREET IMPROVEMENT PROJECT

County PLATTE	City: COLUMBUS	Village:				
Location Description: 14th, 15th, and 20th Avenues between 11th Street & 12th Street						
EXISTING SURFACE TYPE AND STRUCTURES: (Such As Dirt, Gravel, Asphalt, Concrete, Culvert Or Bridge) Gravel						
Average Daily Traffic: 2023 = <u>200</u> , 2043 = <u>300</u>		Classification Type: (As Shown On Functional Classification Map) Local				
Proposed Improvement						
Design Standard Number: Municipal		Surfacing Concrete	Thickness 6"	Width 33'		
<input checked="" type="checkbox"/> Grading	<input checked="" type="checkbox"/> Concrete	<input type="checkbox"/> Right Of Way	<input type="checkbox"/> Lighting			
<input type="checkbox"/> Aggregate	<input checked="" type="checkbox"/> Curb & Gutter	<input checked="" type="checkbox"/> Utility Adjustments			
<input type="checkbox"/> Armor Coat	<input checked="" type="checkbox"/> Drainage Structures	<input type="checkbox"/> Fencing			
<input type="checkbox"/> Asphalt	<input checked="" type="checkbox"/> Erosion Control	<input checked="" type="checkbox"/> Sidewalks			
Bridge To Remain In Place:	Roadway Width	Length	Type			
New Bridge:	Roadway Width	Length	Type			
Box Culvert:	Span	Rise	Length	Type		
Culvert:	Diameter	Length	Type			
Bridges and Culverts Sized	<input type="checkbox"/> Yes <input checked="" type="checkbox"/> N/A <input type="checkbox"/> Hydraulic Analysis Pending					
OTHER CONSTRUCTION FEATURES: Paving over existing Gravel Roadway w/Misc. grading						
ESTIMATED COST (In Thousands) *OPTIONAL	*COUNTY	*CITY	*STATE	*FEDERAL	*OTHER	TOTAL
		290				290
PROJECT LENGTH (Nearest Tenth, State Unit of Measure) 0.3 Miles			Project No.: M211(36)			
Signature: 		Title: City Engineer		Date: August 14, 2023		

BOARD OF PUBLIC ROADS CLASSIFICATIONS AND STANDARDS
FORM 7 ONE-AND SIX-YEAR PLAN
HIGHWAY OR STREET IMPROVEMENT PROJECT

County PLATTE	City: COLUMBUS	Village:				
Location Description: Curb & Gutter (6th Street) 24 th Avenue to 26th Avenue, north side of 6 th Street, 26 th Avenue to 27th Avenue The above is what remains of this project						
EXISTING SURFACE TYPE AND STRUCTURES: (Such As Dirt, Gravel, Asphalt, Concrete, Culvert Or Bridge) 20' - 6" Concrete Paving (no curb and gutter)						
Average Daily Traffic: 2023 = <u>300</u> , 2043 = <u>500</u>	Classification Type: (As Shown On Functional Classification Map) <p style="text-align: center;">Local</p>					
Proposed Improvement						
Design Standard Number: <p style="text-align: center;">Municipal</p>	Surfacing <p style="text-align: center;">Concrete</p>	Thickness <p style="text-align: center;">6"</p>				
		Width <p style="text-align: center;">33'</p>				
<input checked="" type="checkbox"/> Grading <input checked="" type="checkbox"/> Concrete <input type="checkbox"/> Right Of Way <input type="checkbox"/> Lighting <input type="checkbox"/> Aggregate <input checked="" type="checkbox"/> Curb & Gutter <input checked="" type="checkbox"/> Utility Adjustments <input type="checkbox"/> Armor Coat <input checked="" type="checkbox"/> Drainage Structures <input type="checkbox"/> Fencing <input type="checkbox"/> Asphalt <input checked="" type="checkbox"/> Erosion Control <input type="checkbox"/> Sidewalks						
Bridge To Remain In Place:	Roadway Width	Length	Type			
New Bridge:	Roadway Width	Length	Type			
Box Culvert:	Span	Rise	Length	Type		
Culvert:	Diameter	Length	Type			
Bridges and Culverts Sized	<input type="checkbox"/> Yes <input checked="" type="checkbox"/> N/A <input type="checkbox"/> Hydraulic Analysis Pending					
OTHER CONSTRUCTION FEATURES: Curb & Gutter 5 1/2 ' extension on present 22' paving on both sides makes a 33' paving.						
ESTIMATED COST (In Thousands) *OPTIONAL	*COUNTY	*CITY	*STATE	*FEDERAL	*OTHER	TOTAL
		110				110
PROJECT LENGTH (Nearest Tenth, State Unit of Measure) <p style="text-align: center;">0.3 Miles</p>				Project No.: <p style="text-align: center;">M211(39)</p>		
Signature: 				Title: City Engineer		Date: August 14, 2023

BOARD OF PUBLIC ROADS CLASSIFICATIONS AND STANDARDS
FORM 7 ONE-AND SIX-YEAR PLAN
HIGHWAY OR STREET IMPROVEMENT PROJECT

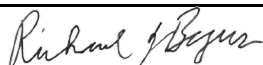
County PLATTE	City: COLUMBUS	Village:				
Location Description: Storm Sewer East Park Addition and 17 Street to Agricultural Park						
EXISTING SURFACE TYPE AND STRUCTURES: (Such As Dirt, Gravel, Asphalt, Concrete, Culvert Or Bridge) Asphalt and Concrete Street Crossings						
Average Daily Traffic: 2023 = <u>NA</u> , 2043 = <u>NA</u>		Classification Type: (As Shown On Functional Classification Map) N/A				
Proposed Improvement						
Design Standard Number: Municipal		Surfacing	Thickness	Width		
<input type="checkbox"/> Grading	<input type="checkbox"/> Concrete	<input type="checkbox"/> Right Of Way	<input type="checkbox"/> Lighting			
<input type="checkbox"/> Aggregate	<input type="checkbox"/> Curb & Gutter	<input type="checkbox"/> Utility Adjustments			
<input type="checkbox"/> Armor Coat	<input checked="" type="checkbox"/> Drainage Structures	<input type="checkbox"/> Fencing			
<input type="checkbox"/> Asphalt	<input checked="" type="checkbox"/> Erosion Control	<input type="checkbox"/> Sidewalks			
Bridge To Remain In Place:	Roadway Width	Length	Type			
New Bridge:	Roadway Width	Length	Type			
Box Culvert:	Span	Rise	Length	Type		
Culvert:	Diameter 48" to 54"	Length	Type RCP			
Bridges and Culverts Sized	<input type="checkbox"/> Yes <input checked="" type="checkbox"/> N/A <input type="checkbox"/> Hydraulic Analysis Pending					
OTHER CONSTRUCTION FEATURES: Assist drainage East Park by enlarging storm sewer system.						
ESTIMATED COST (In Thousands) *OPTIONAL	*COUNTY	*CITY	*STATE	*FEDERAL	*OTHER	TOTAL
		2,000				2,000
PROJECT LENGTH (Nearest Tenth, State Unit of Measure) 0.5 Miles			Project No.: M211(44)			
Signature: 			Title: City Engineer		Date: August 14, 2023	

BOARD OF PUBLIC ROADS CLASSIFICATIONS AND STANDARDS
FORM 7 ONE-AND SIX-YEAR PLAN
HIGHWAY OR STREET IMPROVEMENT PROJECT

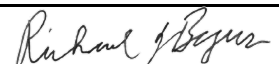
County PLATTE	City: COLUMBUS	Village:				
Location Description: <p style="text-align: center;">Storm Sewer Improvement: 30th Avenue from 22nd to 23rd Streets</p> <p style="text-align: center;">20th Street from 30th Avenue to 33rd Avenue</p>						
EXISTING SURFACE TYPE AND STRUCTURES: (Such As Dirt, Gravel, Asphalt, Concrete, Culvert Or Bridge) <p style="text-align: center;">Concrete</p>						
Average Daily Traffic: 2023 = <u>400</u> , 2043 = <u>500</u>	Classification Type: (As Shown On Functional Classification Map) <p style="text-align: center;">Local</p>					
Proposed Improvement						
Design Standard Number:	Surfacing	Thickness				
<input type="checkbox"/> Grading <input type="checkbox"/> Concrete <input type="checkbox"/> Right Of Way <input type="checkbox"/> Lighting <input type="checkbox"/> Aggregate <input checked="" type="checkbox"/> Curb & Gutter <input type="checkbox"/> Utility Adjustments <input type="checkbox"/> Armor Coat <input checked="" type="checkbox"/> Drainage Structures <input type="checkbox"/> Fencing <input type="checkbox"/> Asphalt <input checked="" type="checkbox"/> Erosion Control <input type="checkbox"/> Sidewalks						
Bridge To Remain In Place:	Roadway Width	Length	Type			
New Bridge:	Roadway Width	Length	Type			
Box Culvert:	Span	Rise	Length	Type		
Culvert:	Diameter 18"	Length	Type RCP			
Bridges and Culverts Sized	<input type="checkbox"/> Yes <input checked="" type="checkbox"/> N/A <input type="checkbox"/> Hydraulic Analysis Pending					
OTHER CONSTRUCTION FEATURES: <p style="text-align: center;">Improve storm sewer drainage in this area.</p>						
ESTIMATED COST (In Thousands) *OPTIONAL	*COUNTY	*CITY	*STATE	*FEDERAL	*OTHER	TOTAL
		110				110
PROJECT LENGTH (Nearest Tenth, State Unit of Measure)				Project No.:		
				M211(57)		
Signature: 				Title: City Engineer		Date: August 14, 2023

BOARD OF PUBLIC ROADS CLASSIFICATIONS AND STANDARDS
FORM 7 ONE-AND SIX-YEAR PLAN
HIGHWAY OR STREET IMPROVEMENT PROJECT

County PLATTE	City: COLUMBUS	Village:				
Location Description: <p style="text-align: center;">Air Vista Drive southwest from 30th Street to point 211' north of 27th Street</p> <p style="text-align: center;">Where it joins 33' concrete paving.</p>						
EXISTING SURFACE TYPE AND STRUCTURES: (Such As Dirt, Gravel, Asphalt, Concrete, Culvert Or Bridge) <p style="text-align: center;">Gravel</p>						
Average Daily Traffic: 2023 = <u>100</u> , 2043 = <u>200</u>		Classification Type: (As Shown On Functional Classification Map) <p style="text-align: center;">Local</p>				
Proposed Improvement						
Design Standard Number: Municipal		Surfacing Concrete	Thickness 6"	Width 33'		
<input checked="" type="checkbox"/> Grading	<input checked="" type="checkbox"/> Concrete	<input type="checkbox"/> Right Of Way	<input checked="" type="checkbox"/> Lighting			
<input type="checkbox"/> Aggregate	<input checked="" type="checkbox"/> Curb & Gutter	<input checked="" type="checkbox"/> Utility Adjustments			
<input type="checkbox"/> Armor Coat	<input checked="" type="checkbox"/> Drainage Structures	<input type="checkbox"/> Fencing			
<input type="checkbox"/> Asphalt	<input checked="" type="checkbox"/> Erosion Control	<input checked="" type="checkbox"/> Sidewalks			
Bridge To Remain In Place:	Roadway Width	Length	Type			
New Bridge:	Roadway Width	Length	Type			
Box Culvert:	Span	Rise	Length	Type		
Culvert:	Diameter	Length		Type		
Bridges and Culverts Sized	<input type="checkbox"/> Yes <input checked="" type="checkbox"/> N/A <input type="checkbox"/> Hydraulic Analysis Pending					
OTHER CONSTRUCTION FEATURES: <p style="text-align: center;">Paving over existing Gravel Roadway w/Misc. grading</p>						
ESTIMATED COST (In Thousands) *OPTIONAL	*COUNTY	*CITY	*STATE	*FEDERAL	*OTHER	TOTAL
		350				350
PROJECT LENGTH (Nearest Tenth, State Unit of Measure) 0.3 Miles				Project No.: M211(62)		
Signature: 			Title: City Engineer		Date: August 14, 2023	

BOARD OF PUBLIC ROADS CLASSIFICATIONS AND STANDARDS
FORM 7 ONE-AND SIX-YEAR PLAN
HIGHWAY OR STREET IMPROVEMENT PROJECT

County PLATTE	City: COLUMBUS	Village:				
Location Description: 12th Street, 37th Avenue to 38 1/2 Avenue - 40 1/2 Avenue to 41st Avenue 13th Street, 40 1/2 Avenue to 41st Avenue, 37th Avenue, 13th Street 1/2 block South 38th Avenue, 12th Street to 13th Street, 1/2 block North, Oida Addition						
EXISTING SURFACE TYPE AND STRUCTURES: (Such As Dirt, Gravel, Asphalt, Concrete, Culvert Or Bridge) Gravel						
Average Daily Traffic: 2023 = <u>100</u> , 2043 = <u>200</u>	Classification Type: (As Shown On Functional Classification Map) Local					
Proposed Improvement						
Design Standard Number: Municipal	Surfacing Concrete	Thickness 6" Width 33'				
<input checked="" type="checkbox"/> Grading <input checked="" type="checkbox"/> Concrete <input type="checkbox"/> Right Of Way <input type="checkbox"/> Lighting <input type="checkbox"/> Aggregate <input checked="" type="checkbox"/> Curb & Gutter <input checked="" type="checkbox"/> Utility Adjustments <input type="checkbox"/> Armor Coat <input checked="" type="checkbox"/> Drainage Structures <input type="checkbox"/> Fencing <input type="checkbox"/> Asphalt <input checked="" type="checkbox"/> Erosion Control <input type="checkbox"/> Sidewalks						
Bridge To Remain In Place:	Roadway Width	Length	Type			
New Bridge:	Roadway Width	Length	Type			
Box Culvert:	Span	Rise	Length	Type		
Culvert:	Diameter	Length	Type			
Bridges and Culverts Sized	<input type="checkbox"/> Yes <input checked="" type="checkbox"/> N/A <input type="checkbox"/> Hydraulic Analysis Pending					
OTHER CONSTRUCTION FEATURES: 33' Concrete, Curb & Gutter and Storm Sewer						
ESTIMATED COST (In Thousands) *OPTIONAL	*COUNTY	*CITY	*STATE	*FEDERAL	*OTHER	TOTAL
		260				260
PROJECT LENGTH (Nearest Tenth, State Unit of Measure) 0.2 Miles				Project No.: M211(64)		
Signature: 				Title: City Engineer		Date: August 14, 2023

BOARD OF PUBLIC ROADS CLASSIFICATIONS AND STANDARDS
FORM 7 ONE-AND SIX-YEAR PLAN
HIGHWAY OR STREET IMPROVEMENT PROJECT

County PLATTE	City: COLUMBUS	Village:				
Location Description: <div style="text-align: center;">22nd Avenue between 6th Street to 7th Street</div> <hr/> <div style="text-align: center;">25th Avenue between 6th Street to 7th Street</div>						
EXISTING SURFACE TYPE AND STRUCTURES: (Such As Dirt, Gravel, Asphalt, Concrete, Culvert Or Bridge) <div style="text-align: center;">Gravel</div>						
Average Daily Traffic: 2023 = <u>100</u> , 2043 = <u>200</u>		Classification Type: (As Shown On Functional Classification Map) Local				
Proposed Improvement						
Design Standard Number: Municipal		Surfacing Concrete	Thickness 6"	Width 33'		
<input checked="" type="checkbox"/> Grading	<input checked="" type="checkbox"/> Concrete	<input type="checkbox"/> Right Of Way	<input checked="" type="checkbox"/> Lighting			
<input type="checkbox"/> Aggregate	<input checked="" type="checkbox"/> Curb & Gutter	<input checked="" type="checkbox"/> Utility Adjustments			
<input type="checkbox"/> Armor Coat	<input checked="" type="checkbox"/> Drainage Structures	<input type="checkbox"/> Fencing			
<input type="checkbox"/> Asphalt	<input checked="" type="checkbox"/> Erosion Control	<input checked="" type="checkbox"/> Sidewalks			
Bridge To Remain In Place:	Roadway Width	Length	Type			
New Bridge:	Roadway Width	Length	Type			
Box Culvert:	Span	Rise	Length	Type		
Culvert:	Diameter	Length	Type			
Bridges and Culverts Sized	<input type="checkbox"/> Yes <input checked="" type="checkbox"/> N/A <input type="checkbox"/> Hydraulic Analysis Pending					
OTHER CONSTRUCTION FEATURES: <div style="text-align: center;">33' Concrete, Curb & Gutter and Storm Sewer</div>						
ESTIMATED COST (In Thousands) *OPTIONAL	*COUNTY	*CITY	*STATE	*FEDERAL	*OTHER	TOTAL
		115				115
PROJECT LENGTH (Nearest Tenth, State Unit of Measure) 0.1 Miles			Project No.: M211(71)			
Signature: 			Title: City Engineer		Date: August 14, 2023	

BOARD OF PUBLIC ROADS CLASSIFICATIONS AND STANDARDS
FORM 7 ONE-AND SIX-YEAR PLAN
HIGHWAY OR STREET IMPROVEMENT PROJECT

County PLATTE	City: COLUMBUS	Village:				
Location Description: Gates 1 st Subdivision – 2 nd Avenue, 8 th Street to 10 th Street, 10 th Street, 3 rd Avenue to 2 nd Avenue <hr/> Gates 2 nd Subdivision – 2 nd Avenue south and southeasterly and return to 9 th Avenue.						
EXISTING SURFACE TYPE AND STRUCTURES: (Such As Dirt, Gravel, Asphalt, Concrete, Culvert Or Bridge) <hr/> <p style="text-align: center;">Gravel</p> <hr/>						
Average Daily Traffic: 2023 = <u>100</u> , 2043 = <u>200</u>		Classification Type: (As Shown On Functional Classification Map) Local				
Proposed Improvement						
Design Standard Number: Municipal		Surfacing Concrete	Thickness 6"	Width 33'		
<input checked="" type="checkbox"/> Grading	<input checked="" type="checkbox"/> Concrete	<input type="checkbox"/> Right Of Way	<input checked="" type="checkbox"/> Lighting			
<input type="checkbox"/> Aggregate	<input checked="" type="checkbox"/> Curb & Gutter	<input checked="" type="checkbox"/> Utility Adjustments			
<input type="checkbox"/> Armor Coat	<input checked="" type="checkbox"/> Drainage Structures	<input type="checkbox"/> Fencing			
<input type="checkbox"/> Asphalt	<input checked="" type="checkbox"/> Erosion Control	<input checked="" type="checkbox"/> Sidewalks			
Bridge To Remain In Place:	Roadway Width	Length	Type			
New Bridge:	Roadway Width	Length	Type			
Box Culvert:	Span	Rise	Length	Type		
Culvert:	Diameter	Length	Type			
Bridges and Culverts Sized	<input type="checkbox"/> Yes <input checked="" type="checkbox"/> N/A <input type="checkbox"/> Hydraulic Analysis Pending					
OTHER CONSTRUCTION FEATURES: <p style="text-align: center;">33' Concrete, Curb & Gutter and Storm Sewer</p>						
ESTIMATED COST (In Thousands) *OPTIONAL	*COUNTY	*CITY	*STATE	*FEDERAL	*OTHER	TOTAL
		360				360
PROJECT LENGTH (Nearest Tenth, State Unit of Measure) 0.3 Miles			Project No.: M211(111)			
Signature: 			Title: City Engineer		Date: August 14, 2023	

BOARD OF PUBLIC ROADS CLASSIFICATIONS AND STANDARDS
FORM 7 ONE-AND SIX-YEAR PLAN
HIGHWAY OR STREET IMPROVEMENT PROJECT

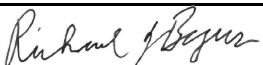
County PLATTE	City: COLUMBUS	Village:				
Location Description: Crumley Subdivision – 6 th Street and 3 rd Avenue – 5 th Street east to City Limits, also 2 nd Avenue cul-de-sac.						
EXISTING SURFACE TYPE AND STRUCTURES: (Such As Dirt, Gravel, Asphalt, Concrete, Culvert Or Bridge) Gravel						
Average Daily Traffic: 2023 = <u>100</u> , 2043 = <u>200</u>		Classification Type: (As Shown On Functional Classification Map) Local				
Proposed Improvement						
Design Standard Number: <u>Municipal</u>		Surfacing Concrete	Thickness 6"	Width 33'		
<input checked="" type="checkbox"/> Grading	<input checked="" type="checkbox"/> Concrete	<input type="checkbox"/> Right Of Way	<input checked="" type="checkbox"/> Lighting			
<input type="checkbox"/> Aggregate	<input checked="" type="checkbox"/> Curb & Gutter	<input checked="" type="checkbox"/> Utility Adjustments			
<input type="checkbox"/> Armor Coat	<input checked="" type="checkbox"/> Drainage Structures	<input type="checkbox"/> Fencing			
<input type="checkbox"/> Asphalt	<input checked="" type="checkbox"/> Erosion Control	<input checked="" type="checkbox"/> Sidewalks			
Bridge To Remain In Place:	Roadway Width	Length	Type			
New Bridge:	Roadway Width	Length	Type			
Box Culvert:	Span	Rise	Length	Type		
Culvert:	Diameter	Length	Type			
Bridges and Culverts Sized	<input type="checkbox"/> Yes <input checked="" type="checkbox"/> N/A <input type="checkbox"/> Hydraulic Analysis Pending					
OTHER CONSTRUCTION FEATURES: 33' Concrete, Curb & Gutter and Storm Sewer						
ESTIMATED COST (In Thousands) *OPTIONAL	*COUNTY	*CITY	*STATE	*FEDERAL	*OTHER	TOTAL
		260				260
PROJECT LENGTH (Nearest Tenth, State Unit of Measure) 0.1 Miles			Project No.: M211(112)			
Signature: 			Title: City Engineer		Date: August 14, 2023	

BOARD OF PUBLIC ROADS CLASSIFICATIONS AND STANDARDS
FORM 7 ONE-AND SIX-YEAR PLAN
HIGHWAY OR STREET IMPROVEMENT PROJECT

County PLATTE	City: COLUMBUS	Village:				
Location Description: Sand Subdivision and (Replat Part) of Sand Subdivision, 17 th Street, Public Access Road <hr/> From East 12 th Avenue & East 11 th Avenue from 17 th Street north to Public Access <hr/> Road, 17 th Street from East 11 th Avenue west. <hr/>						
EXISTING SURFACE TYPE AND STRUCTURES: (Such As Dirt, Gravel, Asphalt, Concrete, Culvert Or Bridge) <hr/> <p style="text-align: center;">Gravel</p> <hr/>						
Average Daily Traffic: 2023 = <u>400</u> , 2043 = <u>600</u>	Classification Type: (As Shown On Functional Classification Map) <p style="text-align: center;">Local</p>					
Proposed Improvement						
Design Standard Number: <p style="text-align: center;"><u>Municipal</u></p>	Surfacing <p style="text-align: center;">Concrete</p>	Thickness <p style="text-align: center;">8"</p>				
		Width <p style="text-align: center;">33'</p>				
<input checked="" type="checkbox"/> Grading <input checked="" type="checkbox"/> Concrete <input type="checkbox"/> Right Of Way <input checked="" type="checkbox"/> Lighting <input type="checkbox"/> Aggregate <input checked="" type="checkbox"/> Curb & Gutter <input checked="" type="checkbox"/> Utility Adjustments <input type="checkbox"/> Armor Coat <input checked="" type="checkbox"/> Drainage Structures <input type="checkbox"/> Fencing <input type="checkbox"/> Asphalt <input checked="" type="checkbox"/> Erosion Control <input checked="" type="checkbox"/> Sidewalks						
Bridge To Remain In Place:	Roadway Width	Length	Type			
New Bridge:	Roadway Width	Length	Type			
Box Culvert:	Span	Rise	Length Type			
Culvert:	Diameter	Length	Type			
Bridges and Culverts Sized	<input type="checkbox"/> Yes <input checked="" type="checkbox"/> N/A <input type="checkbox"/> Hydraulic Analysis Pending					
OTHER CONSTRUCTION FEATURES: <hr/> <p style="text-align: center;">33' Concrete, Curb & Gutter and Storm Sewer</p> <hr/>						
ESTIMATED COST (In Thousands) *OPTIONAL	*COUNTY	*CITY	*STATE	*FEDERAL	*OTHER	TOTAL
		1130				1130
PROJECT LENGTH (Nearest Tenth, State Unit of Measure) 0.8 Miles				Project No.: M211(114)		
Signature: 				Title: City Engineer		Date: August 14, 2023

BOARD OF PUBLIC ROADS CLASSIFICATIONS AND STANDARDS
FORM 7 ONE-AND SIX-YEAR PLAN
HIGHWAY OR STREET IMPROVEMENT PROJECT

County PLATTE	City: COLUMBUS	Village:				
Location Description: West Parkway 1st and 2nd Subdivisions; 12th Street - Munroe Avenue to 46th Avenue; 13th Street - 46th Avenue to 48th Avenue; 14th Street - 248' East of Munroe Avenue to 48th Avenue; Munroe Avenue - 11th Street to 14th Street; 46th Avenue - 11th Street to 14th Street						
EXISTING SURFACE TYPE AND STRUCTURES: (Such As Dirt, Gravel, Asphalt, Concrete, Culvert Or Bridge) _____ _____ _____ <p style="text-align: center;">Gravel</p> _____ _____						
Average Daily Traffic: 2023 = <u>100</u> , 2043 = <u>200</u>		Classification Type: (As Shown On Functional Classification Map) <p style="text-align: center;">Local</p>				
Proposed Improvement						
Design Standard Number: Municipal		Surfacing Concrete	Thickness 6"	Width 33'		
<input checked="" type="checkbox"/> Grading	<input checked="" type="checkbox"/> Concrete	<input type="checkbox"/> Right Of Way	<input checked="" type="checkbox"/> Lighting			
<input type="checkbox"/> Aggregate	<input checked="" type="checkbox"/> Curb & Gutter	<input checked="" type="checkbox"/> Utility Adjustments		_____		
<input type="checkbox"/> Armor Coat	<input checked="" type="checkbox"/> Drainage Structures	<input type="checkbox"/> Fencing	_____			
<input type="checkbox"/> Asphalt	<input type="checkbox"/> Erosion Control	<input checked="" type="checkbox"/> Sidewalks	_____			
Bridge To Remain In Place:	Roadway Width	Length	Type			
New Bridge:	Roadway Width	Length	Type			
Box Culvert:	Span	Rise	Length	Type		
Culvert:	Diameter	Length		Type		
Bridges and Culverts Sized	<input type="checkbox"/> Yes <input checked="" type="checkbox"/> N/A <input type="checkbox"/> Hydraulic Analysis Pending					
OTHER CONSTRUCTION FEATURES: _____ _____ _____ _____ _____ _____ _____ _____						
ESTIMATED COST (In Thousands) *OPTIONAL	*COUNTY	*CITY	*STATE	*FEDERAL	*OTHER	TOTAL
		440				440
PROJECT LENGTH (Nearest Tenth, State Unit of Measure) 0.4 Miles				Project No.: M211(118)		
Signature: 			Title: City Engineer		Date: August 14, 2023	

BOARD OF PUBLIC ROADS CLASSIFICATIONS AND STANDARDS
FORM 7 ONE-AND SIX-YEAR PLAN
HIGHWAY OR STREET IMPROVEMENT PROJECT

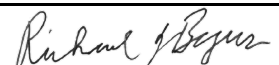
County PLATTE	City: COLUMBUS	Village:
Location Description: 26th Avenue from 3 rd to 5 th Streets; 25 th Avenue from 4 th to 5 th Streets; 24 th Avenue from 4 th Street North and South 1/2 Block; 4 th Street from 23 rd to 24 th Avenue		
EXISTING SURFACE TYPE AND STRUCTURES: (Such As Dirt, Gravel, Asphalt, Concrete, Culvert Or Bridge) Gravel		
Average Daily Traffic: 2023 = <u>200</u> , 2043 = <u>300</u>	Classification Type: (As Shown On Functional Classification Map) Local	
Proposed Improvement		
Design Standard Number: <u>Municipal</u>	Surfacing Concrete	Thickness 6"
		Width 33'
<input checked="" type="checkbox"/> Grading	<input checked="" type="checkbox"/> Concrete	<input type="checkbox"/> Right Of Way
<input type="checkbox"/> Aggregate	<input checked="" type="checkbox"/> Curb & Gutter	<input checked="" type="checkbox"/> Lighting
<input type="checkbox"/> Armor Coat	<input checked="" type="checkbox"/> Drainage Structures	<input type="checkbox"/> Utility Adjustments
<input type="checkbox"/> Asphalt	<input checked="" type="checkbox"/> Erosion Control	<input type="checkbox"/> Fencing
		<input checked="" type="checkbox"/> Sidewalks
Bridge To Remain In Place:	Roadway Width	Length
		Type
New Bridge:	Roadway Width	Length
		Type
Box Culvert:	Span	Rise
		Length
		Type
Culvert:	Diameter	Length
		Type
Bridges and Culverts Sized	<input type="checkbox"/> Yes <input checked="" type="checkbox"/> N/A <input type="checkbox"/> Hydraulic Analysis Pending	
OTHER CONSTRUCTION FEATURES: 33' Concrete Paving, Curb & Gutter, Storm Sewer		
ESTIMATED COST (In Thousands) *OPTIONAL	*COUNTY	*CITY
		340
	*STATE	*FEDERAL
		*OTHER
		TOTAL
		340
PROJECT LENGTH (Nearest Tenth, State Unit of Measure) .3 Miles	Project No.: M211(157)	
Signature: 	Title: City Engineer	Date: August 14, 2023

BOARD OF PUBLIC ROADS CLASSIFICATIONS AND STANDARDS
FORM 7 ONE-AND SIX-YEAR PLAN
HIGHWAY OR STREET IMPROVEMENT PROJECT

County PLATTE	City: COLUMBUS	Village:				
Location Description: <p style="text-align: center;">Johannes Subdivision</p>						
EXISTING SURFACE TYPE AND STRUCTURES: (Such As Dirt, Gravel, Asphalt, Concrete, Culvert Or Bridge) <p style="text-align: center;">Gravel</p>						
Average Daily Traffic: 2023 = <u>150</u> , 2043 = <u>300</u>	Classification Type: (As Shown On Functional Classification Map) <p style="text-align: center;">Local</p>					
Proposed Improvement						
Design Standard Number: <p style="text-align: center;">Municipal</p>	Surfacing <p style="text-align: center;">Concrete</p>	Thickness <p style="text-align: center;">6"</p>				
		Width <p style="text-align: center;">33'</p>				
<input checked="" type="checkbox"/> Grading <input checked="" type="checkbox"/> Concrete <input type="checkbox"/> Right Of Way <input type="checkbox"/> Lighting <input type="checkbox"/> Aggregate <input checked="" type="checkbox"/> Curb & Gutter <input checked="" type="checkbox"/> Utility Adjustments <input type="checkbox"/> Armor Coat <input checked="" type="checkbox"/> Drainage Structures <input type="checkbox"/> Fencing <input type="checkbox"/> Asphalt <input checked="" type="checkbox"/> Erosion Control <input checked="" type="checkbox"/> Sidewalks						
Bridge To Remain In Place:	Roadway Width	Length	Type			
New Bridge:	Roadway Width	Length	Type			
Box Culvert:	Span	Rise	Length	Type		
Culvert:	Diameter	Length	Type			
Bridges and Culverts Sized	<input type="checkbox"/> Yes <input checked="" type="checkbox"/> N/A <input type="checkbox"/> Hydraulic Analysis Pending					
OTHER CONSTRUCTION FEATURES: <p style="text-align: center;">Paving over existing Gravel Roadway w/Misc. grading</p>						
ESTIMATED COST (In Thousands) *OPTIONAL	*COUNTY	*CITY	*STATE	*FEDERAL	*OTHER	TOTAL
		2,500				2,500
PROJECT LENGTH (Nearest Tenth, State Unit of Measure) <p style="text-align: center;">1.4 Miles</p>				Project No.: <p style="text-align: center;">M211(190)</p>		
Signature: 				Title: City Engineer		Date: August 14, 2023

BOARD OF PUBLIC ROADS CLASSIFICATIONS AND STANDARDS
FORM 7 ONE-AND SIX-YEAR PLAN
HIGHWAY OR STREET IMPROVEMENT PROJECT

County PLATTE	City: COLUMBUS	Village:				
Location Description: 10 th Avenue Lovers Lane to 5 th Street, Lovers Lane 5 th Street to 10 th Avenue, 7 th Avenue from Lovers Lane to South 5 th Street East to 3 rd Avenue.						
EXISTING SURFACE TYPE AND STRUCTURES: (Such As Dirt, Gravel, Asphalt, Concrete, Culvert Or Bridge) Asphalt						
Average Daily Traffic: 2023 = <u>765</u> , 2043 = <u>950</u>	Classification Type: (As Shown On Functional Classification Map) Collector					
Proposed Improvement						
Design Standard Number: <u>Municipal</u>	Surfacing Concrete	Thickness 8" Width 41'				
<input checked="" type="checkbox"/> Grading <input checked="" type="checkbox"/> Concrete <input type="checkbox"/> Right Of Way <input type="checkbox"/> Lighting <input type="checkbox"/> Aggregate <input checked="" type="checkbox"/> Curb & Gutter <input checked="" type="checkbox"/> Utility Adjustments <input type="checkbox"/> Armor Coat <input checked="" type="checkbox"/> Drainage Structures <input type="checkbox"/> Fencing <input type="checkbox"/> Asphalt <input checked="" type="checkbox"/> Erosion Control <input checked="" type="checkbox"/> Sidewalks						
Bridge To Remain In Place:	Roadway Width	Length	Type			
New Bridge:	Roadway Width	Length	Type			
Box Culvert:	Span	Rise	Length	Type		
Culvert:	Diameter	Length	Type			
Bridges and Culverts Sized	<input type="checkbox"/> Yes <input checked="" type="checkbox"/> N/A <input type="checkbox"/> Hydraulic Analysis Pending					
OTHER CONSTRUCTION FEATURES: 41' Concrete Paving, Curb & Gutter with Storm Sewer.						
ESTIMATED COST (In Thousands) *OPTIONAL	*COUNTY	*CITY	*STATE	*FEDERAL	*OTHER	TOTAL
		2500				2,500
PROJECT LENGTH (Nearest Tenth, State Unit of Measure) 1.6 Miles				Project No.: M211(220)		
Signature: 				Title: City Engineer		Date: August 14, 2023

BOARD OF PUBLIC ROADS CLASSIFICATIONS AND STANDARDS
FORM 7 ONE-AND SIX-YEAR PLAN
HIGHWAY OR STREET IMPROVEMENT PROJECT

County PLATTE	City: COLUMBUS	Village:				
Location Description: <p style="text-align: center;">East 14th Avenue from 23rd Street north $\frac{3}{4}$ mile</p>						
EXISTING SURFACE TYPE AND STRUCTURES: (Such As Dirt, Gravel, Asphalt, Concrete, Culvert Or Bridge) <p style="text-align: center;">Asphalt rural section, 2 lane</p>						
Average Daily Traffic: 2023 = <u>1350</u> , 2043 = <u>1800</u>	Classification Type: (As Shown On Functional Classification Map) <p style="text-align: center;">Collector</p>					
Proposed Improvement						
Design Standard Number: <p style="text-align: center;">Municipal</p>	Surfacing <p style="text-align: center;">Concrete</p>	Thickness <p style="text-align: center;">8"</p>				
		Width <p style="text-align: center;">41'</p>				
<input checked="" type="checkbox"/> Grading	<input checked="" type="checkbox"/> Concrete	<input checked="" type="checkbox"/> Right Of Way				
<input type="checkbox"/> Aggregate	<input checked="" type="checkbox"/> Curb & Gutter	<input checked="" type="checkbox"/> Utility Adjustments				
<input type="checkbox"/> Armor Coat	<input checked="" type="checkbox"/> Drainage Structures	<input type="checkbox"/> Fencing				
<input type="checkbox"/> Asphalt	<input checked="" type="checkbox"/> Erosion Control	<input type="checkbox"/> Sidewalks				
<input type="checkbox"/> Lighting						
Bridge To Remain In Place:	Roadway Width	Length	Type			
New Bridge: X	Roadway Width	Length	Type			
Box Culvert:	Span	Rise	Length	Type		
Culvert:	Diameter	Length	Type			
Bridges and Culverts Sized	<input type="checkbox"/> Yes <input checked="" type="checkbox"/> N/A <input type="checkbox"/> Hydraulic Analysis Pending					
OTHER CONSTRUCTION FEATURES: <p style="text-align: center;">Federal Funds, Purchase Program and Assessments</p>						
ESTIMATED COST (In Thousands) *OPTIONAL	*COUNTY	*CITY	*STATE	*FEDERAL	*OTHER	TOTAL
		1900				1900
PROJECT LENGTH (Nearest Tenth, State Unit of Measure) <p style="text-align: center;">0.8 MILES</p>				Project No.: <p style="text-align: center;">M211(257)</p>		
Signature: 				Title: <p style="text-align: center;">City Engineer</p>		Date: <p style="text-align: center;">August 14, 2023</p>

BOARD OF PUBLIC ROADS CLASSIFICATIONS AND STANDARDS
FORM 7 ONE-AND SIX-YEAR PLAN
HIGHWAY OR STREET IMPROVEMENT PROJECT

County PLATTE	City: COLUMBUS	Village:				
Location Description: <p style="text-align: center;">26th Avenue from 27rd Street to 32nd Street</p>						
EXISTING SURFACE TYPE AND STRUCTURES: (Such As Dirt, Gravel, Asphalt, Concrete, Culvert Or Bridge) <p style="text-align: center;">Concrete</p>						
Average Daily Traffic: 2023 = <u>5450</u> , 2043 = <u>7500</u>	Classification Type: (As Shown On Functional Classification Map) <p style="text-align: center;">Collector</p>					
Proposed Improvement						
Design Standard Number: <p style="text-align: center;">Municipal</p>	Surfacing Concrete 8" Thickness 33' Width					
<input type="checkbox"/> Grading <input checked="" type="checkbox"/> Concrete <input type="checkbox"/> Right Of Way <input type="checkbox"/> Lighting <input type="checkbox"/> Aggregate <input checked="" type="checkbox"/> Curb & Gutter <input checked="" type="checkbox"/> Utility Adjustments <input type="checkbox"/> Armor Coat <input type="checkbox"/> Drainage Structures <input type="checkbox"/> Fencing <input type="checkbox"/> Asphalt <input checked="" type="checkbox"/> Erosion Control <input type="checkbox"/> Sidewalks						
Bridge To Remain In Place:	Roadway Width	Length	Type			
New Bridge:	Roadway Width	Length	Type			
Box Culvert:	Span	Rise	Length	Type		
Culvert:	Diameter	Length	Type			
Bridges and Culverts Sized	<input type="checkbox"/> Yes <input checked="" type="checkbox"/> N/A <input type="checkbox"/> Hydraulic Analysis Pending					
OTHER CONSTRUCTION FEATURES: <p style="text-align: center;">Federal Funds Purchase Program</p>						
ESTIMATED COST (In Thousands) *OPTIONAL	*COUNTY	*CITY	*STATE	*FEDERAL	*OTHER	TOTAL
		820				820
PROJECT LENGTH (Nearest Tenth, State Unit of Measure) <p style="text-align: center;">0.3 MILES</p>				Project No.: <p style="text-align: center;">M211(264)</p>		
Signature: 				Title: <p style="text-align: center;">CITY ENGINEER</p>		Date: <p style="text-align: center;">August 14, 2023</p>

BOARD OF PUBLIC ROADS CLASSIFICATIONS AND STANDARDS
FORM 7 ONE-AND SIX-YEAR PLAN
HIGHWAY OR STREET IMPROVEMENT PROJECT

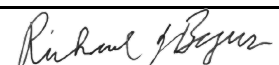
County PLATTE	City: COLUMBUS	Village:			
Location Description: <div style="text-align: center;">Howard. Blvd -33rd Avenue to 41st Avenue</div> <hr/> <div style="text-align: center;">14th Street – 33rd Avenue to 23rd Street.</div>					
EXISTING SURFACE TYPE AND STRUCTURES: (Such As Dirt, Gravel, Asphalt, Concrete, Culvert Or Bridge)					
Asphalt over concrete (Approx. 0.7 miles)					
Concrete (Approx. 0.3 Miles)					
Average Daily Traffic: 2023 = <u>6300</u> , 2043 = <u>8500</u>		Classification Type: (As Shown On Functional Classification Map) Principal Arterial			
Proposed Improvement					
Design Standard Number: Municipal					
		Concrete	9" Thick	41'Wide	
<input type="checkbox"/> Grading	<input checked="" type="checkbox"/> Concrete	<input type="checkbox"/> Right Of Way	<input type="checkbox"/> Lighting		
<input type="checkbox"/> Aggregate	<input checked="" type="checkbox"/> Curb & Gutter	<input checked="" type="checkbox"/> Utility Adjustments			
<input type="checkbox"/> Armor Coat	<input checked="" type="checkbox"/> Drainage Structures	<input type="checkbox"/> Fencing			
<input type="checkbox"/> Asphalt	<input type="checkbox"/> Erosion Control	<input checked="" type="checkbox"/> Sidewalks			
Bridge To Remain In Place:					
		Roadway Width	Length	Type	
New Bridge:					
		Roadway Width	Length	Type	
Box Culvert:					
		Span	Rise	Length	Type
Culvert:					
		Diameter	Length	Type	
Bridges and Culverts Sized					
		<input type="checkbox"/> Yes <input checked="" type="checkbox"/> N/A <input type="checkbox"/> Hydraulic Analysis Pending			
OTHER CONSTRUCTION FEATURES:					
41' Concrete Paving, Curb & Gutter with storm sewer					
Federal Funds Purchase Program					
Construct ADA compliant ramps					
ESTIMATED COST (In Thousands)					
*COUNTY	*CITY	*STATE	*FEDERAL	*OTHER	TOTAL
	2700				2700
*OPTIONAL					
PROJECT LENGTH (Nearest Tenth, State Unit of Measure) 1.0 Mile			Project No.: M211(272)		
Signature: 			Title: City Engineer		Date: August 14, 2023

BOARD OF PUBLIC ROADS CLASSIFICATIONS AND STANDARDS
FORM 7 ONE-AND SIX-YEAR PLAN
HIGHWAY OR STREET IMPROVEMENT PROJECT

County PLATTE	City: COLUMBUS	Village:				
Location Description: 48 th Ave. Bradshaw Park Entrance to 11 th St., 11 th St. from 48 th Ave. to 41 st Ave.						
EXISTING SURFACE TYPE AND STRUCTURES: (Such As Dirt, Gravel, Asphalt, Concrete, Culvert Or Bridge) Asphalt & concrete rural section						
Average Daily Traffic: 2023 = <u>1300</u> , 2043 = <u>2300</u>		Classification Type: (As Shown On Functional Classification Map) Collector				
Proposed Improvement						
Design Standard Number: Municipal		Surfacing Concrete	Thickness 9"	Width 33'		
<input checked="" type="checkbox"/> Grading	<input checked="" type="checkbox"/> Concrete	<input type="checkbox"/> Right Of Way	<input checked="" type="checkbox"/> Lighting			
<input type="checkbox"/> Aggregate	<input checked="" type="checkbox"/> Curb & Gutter	<input checked="" type="checkbox"/> Utility Adjustments			
<input type="checkbox"/> Armor Coat	<input checked="" type="checkbox"/> Drainage Structures	<input type="checkbox"/> Fencing			
<input type="checkbox"/> Asphalt	<input checked="" type="checkbox"/> Erosion Control	<input checked="" type="checkbox"/> Sidewalks			
Bridge To Remain In Place:	Roadway Width	Length		Type		
New Bridge:	Roadway Width	Length		Type		
Box Culvert:	Span	Rise	Length	Type		
Culvert:	Diameter	Length			Type	
Bridges and Culverts Sized	<input type="checkbox"/> Yes <input checked="" type="checkbox"/> N/A <input type="checkbox"/> Hydraulic Analysis Pending					
OTHER CONSTRUCTION FEATURES: 33' Wide concrete roadway w/curb & gutter						
ESTIMATED COST (In Thousands) *OPTIONAL	*COUNTY	*CITY	*STATE	*FEDERAL	*OTHER	TOTAL
		2000				2000
PROJECT LENGTH (Nearest Tenth, State Unit of Measure) 0.8 Miles				Project No.: M211(288)		
Signature: <i>Richard J. Boyer</i>				Title: City Engineer	Date: August 14, 2023	

BOARD OF PUBLIC ROADS CLASSIFICATIONS AND STANDARDS
FORM 7 ONE-AND SIX-YEAR PLAN
HIGHWAY OR STREET IMPROVEMENT PROJECT

County PLATTE	City: COLUMBUS	Village:				
Location Description: <p style="text-align: center;">Deerfield Park 2nd Add.</p>						
EXISTING SURFACE TYPE AND STRUCTURES: (Such As Dirt, Gravel, Asphalt, Concrete, Culvert Or Bridge) <p style="text-align: center;">Undeveloped</p>						
Average Daily Traffic: 2023 = <u>0</u> , 2043 = <u>200</u>		Classification Type: (As Shown On Functional Classification Map) <p style="text-align: center;">Local</p>				
Proposed Improvement						
Design Standard Number: <p style="text-align: center;">Municipal</p>		Surfacing Concrete	Thickness 6"	Width 33'		
<input checked="" type="checkbox"/> Grading	<input checked="" type="checkbox"/> Concrete	<input type="checkbox"/> Right Of Way	<input checked="" type="checkbox"/> Lighting			
<input type="checkbox"/> Aggregate	<input checked="" type="checkbox"/> Curb & Gutter	<input type="checkbox"/> Utility Adjustments			
<input type="checkbox"/> Armor Coat	<input checked="" type="checkbox"/> Drainage Structures	<input type="checkbox"/> Fencing			
<input type="checkbox"/> Asphalt	<input checked="" type="checkbox"/> Erosion Control	<input checked="" type="checkbox"/> Sidewalks			
Bridge To Remain In Place:	Roadway Width	Length		Type		
New Bridge:	Roadway Width	Length		Type		
Box Culvert:	Span	Rise	Length	Type		
Culvert:	Diameter	Length			Type	
Bridges and Culverts Sized	<input type="checkbox"/> Yes <input checked="" type="checkbox"/> N/A <input type="checkbox"/> Hydraulic Analysis Pending					
OTHER CONSTRUCTION FEATURES:						
.....						
.....						
.....						
.....						
ESTIMATED COST (In Thousands)	*COUNTY	*CITY	*STATE	*FEDERAL	*OTHER	TOTAL
*OPTIONAL					180	180
PROJECT LENGTH (Nearest Tenth, State Unit of Measure) 0.2 Miles				Project No.:		
				M211(289)		
Signature: <i>Richard J. Boyer</i>			Title: City Engineer		Date: August 14, 2023	

BOARD OF PUBLIC ROADS CLASSIFICATIONS AND STANDARDS
FORM 7 ONE-AND SIX-YEAR PLAN
HIGHWAY OR STREET IMPROVEMENT PROJECT

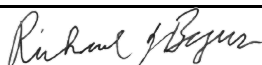
County PLATTE	City: COLUMBUS	Village:
Location Description: Ag Park Drainage 10 th Ave. & 19 th St. drainage to Lost Creek rail road bridge SE corner Christopher's Cove		
EXISTING SURFACE TYPE AND STRUCTURES: (Such As Dirt, Gravel, Asphalt, Concrete, Culvert Or Bridge) Open channel drainage		
Average Daily Traffic: 2023 = <u>N/A</u> , 2043 = <u>N/A</u>	Classification Type: (As Shown On Functional Classification Map) N/A	
Proposed Improvement		
Design Standard Number:		
<input checked="" type="checkbox"/> Grading	<input type="checkbox"/> Concrete	<input type="checkbox"/> Right Of Way
<input type="checkbox"/> Aggregate	<input type="checkbox"/> Curb & Gutter	<input type="checkbox"/> Utility Adjustments
<input type="checkbox"/> Armor Coat	<input checked="" type="checkbox"/> Drainage Structures	<input type="checkbox"/> Fencing
<input type="checkbox"/> Asphalt	<input checked="" type="checkbox"/> Erosion Control	<input type="checkbox"/> Sidewalks
<input type="checkbox"/> Lighting		
Bridge To Remain In Place:	Roadway Width	Length
New Bridge:	Roadway Width	Length
Box Culvert:	Span	Rise
Culvert:	Diameter 24" to twin 30"	Length
Bridges and Culverts Sized	<input type="checkbox"/> Yes <input checked="" type="checkbox"/> N/A <input type="checkbox"/> Hydraulic Analysis Pending	
OTHER CONSTRUCTION FEATURES: Clean out and upgrade drainage system and build retention structure		
ESTIMATED COST (In Thousands) *OPTIONAL	*COUNTY	*CITY
		250
		750
		1,000
PROJECT LENGTH (Nearest Tenth, State Unit of Measure) 0.9 Miles	Project No.: M211(290)	
Signature: 	Title: City Engineer	Date: August 14, 2023

BOARD OF PUBLIC ROADS CLASSIFICATIONS AND STANDARDS
FORM 7 ONE-AND SIX-YEAR PLAN
HIGHWAY OR STREET IMPROVEMENT PROJECT

County PLATTE	City: COLUMBUS	Village:				
Location Description: 21 st Avenue from 1 st to 3 rd Street; 21 st Avenue from 3 rd Street North ½ Block; <hr/> 4 Street from 20 th to 21 st Avenue; 4 th Street from 19 th to 20 th Avenue; <hr/> 3 rd Street from 19 th to 20 th Avenue <hr/>						
EXISTING SURFACE TYPE AND STRUCTURES: (Such As Dirt, Gravel, Asphalt, Concrete, Culvert Or Bridge) _____ Gravel _____ _____						
Average Daily Traffic: 2023 = <u>200</u> , 2043 = <u>300</u>	Classification Type: (As Shown On Functional Classification Map) _____ Local					
Proposed Improvement						
Design Standard Number: Municipal	Surfacing Concrete	Thickness 6"				
		Width 33'				
<input checked="" type="checkbox"/> Grading	<input checked="" type="checkbox"/> Concrete	<input type="checkbox"/> Right Of Way				
<input type="checkbox"/> Aggregate	<input checked="" type="checkbox"/> Curb & Gutter	<input checked="" type="checkbox"/> Utility Adjustments				
<input type="checkbox"/> Armor Coat	<input checked="" type="checkbox"/> Drainage Structures	<input type="checkbox"/> Fencing				
<input type="checkbox"/> Asphalt	<input checked="" type="checkbox"/> Erosion Control	<input type="checkbox"/> Sidewalks				
		<input type="checkbox"/> Lighting				
					
					
					
Bridge To Remain In Place:	Roadway Width	Length	Type			
New Bridge:	Roadway Width	Length	Type			
Box Culvert:	Span	Rise	Length	Type		
Culvert:	Diameter	Length	Type			
Bridges and Culverts Sized	<input type="checkbox"/> Yes <input checked="" type="checkbox"/> N/A <input type="checkbox"/> Hydraulic Analysis Pending					
OTHER CONSTRUCTION FEATURES: _____ _____ 33' Concrete Paving and Storm Sewer _____ _____ _____						
ESTIMATED COST (In Thousands) *OPTIONAL	*COUNTY	*CITY	*STATE	*FEDERAL	*OTHER	TOTAL
		370				370
PROJECT LENGTH (Nearest Tenth, State Unit of Measure) 0.3 Miles				Project No.: M211(301)		
Signature: <i>Richard J. Bogus</i>				Title: City Engineer		Date: August 14, 2023

BOARD OF PUBLIC ROADS CLASSIFICATIONS AND STANDARDS
FORM 7 ONE-AND SIX-YEAR PLAN
HIGHWAY OR STREET IMPROVEMENT PROJECT

County PLATTE	City: COLUMBUS	Village:				
Location Description: <p style="text-align: center;">4 Street from 16th to 17th Avenue; 4 Street From 14th to 15th Avenue</p> <p style="text-align: center;">3rd Street from 14th to 15th Avenue; 3rd Street from 13th to 14th Avenue</p> <p style="text-align: center;">2nd Street from 14th to 15th Avenue; 2nd Street from 13th to 14th Avenue; 15th Avenue 3rd to 4th Street; 13th Avenue from 2nd to 3rd Street</p>						
EXISTING SURFACE TYPE AND STRUCTURES: (Such As Dirt, Gravel, Asphalt, Concrete, Culvert Or Bridge) <p style="text-align: center;">Gravel</p>						
Average Daily Traffic: 2023 = <u>200</u> , 2043 = <u>300</u>	Classification Type: (As Shown On Functional Classification Map) <p style="text-align: center;">Local</p>					
Proposed Improvement						
Design Standard Number: Municipal	Surfacing Concrete	Thickness 6"				
		Width 33'				
<input type="checkbox"/> Grading <input type="checkbox"/> Concrete <input type="checkbox"/> Right Of Way <input type="checkbox"/> Lighting <input type="checkbox"/> Aggregate <input type="checkbox"/> Curb & Gutter <input type="checkbox"/> Utility Adjustments <input type="checkbox"/> Armor Coat <input type="checkbox"/> Drainage Structures <input type="checkbox"/> Fencing <input type="checkbox"/> Asphalt <input type="checkbox"/> Erosion Control <input type="checkbox"/> Sidewalks						
Bridge To Remain In Place:	Roadway Width	Length	Type			
New Bridge:	Roadway Width	Length	Type			
Box Culvert:	Span	Rise	Length Type			
Culvert:	Diameter	Length	Type			
Bridges and Culverts Sized	<input type="checkbox"/> Yes <input checked="" type="checkbox"/> N/A <input type="checkbox"/> Hydraulic Analysis Pending					
OTHER CONSTRUCTION FEATURES: <p style="text-align: center;">33' Concrete Paving and Storm Sewer</p>						
ESTIMATED COST (In Thousands) *OPTIONAL	*COUNTY	*CITY	*STATE	*FEDERAL	*OTHER	TOTAL
		525				525
PROJECT LENGTH (Nearest Tenth, State Unit of Measure) 0.4 Miles				Project No.: M211(302)		
Signature: 				Title: City Engineer		Date: August 14, 2023

BOARD OF PUBLIC ROADS CLASSIFICATIONS AND STANDARDS
FORM 7 ONE-AND SIX-YEAR PLAN
HIGHWAY OR STREET IMPROVEMENT PROJECT

County PLATTE	City: COLUMBUS	Village:				
Location Description: <p style="text-align: center;">Power House Park Trail Phase 2</p> <p style="text-align: center;">North side of Lost Creek Parkway along Lost Creek Flood Control ditch from Wilderness Park Road to 3rd Ave.</p>						
EXISTING SURFACE TYPE AND STRUCTURES: (Such As Dirt, Gravel, Asphalt, Concrete, Culvert Or Bridge) <p style="text-align: center;">Undeveloped Land</p>						
Average Daily Traffic: 2023 = <u>0</u> , 2043 = <u>N/A</u>	Classification Type: (As Shown On Functional Classification Map) <p style="text-align: center;">N/A</p>					
Proposed Improvement						
Design Standard Number: Municipal	Surfacing Concrete	6" 10'				
<input checked="" type="checkbox"/> Grading <input checked="" type="checkbox"/> Concrete <input type="checkbox"/> Right Of Way <input type="checkbox"/> Lighting <input type="checkbox"/> Aggregate <input type="checkbox"/> Curb & Gutter <input type="checkbox"/> Utility Adjustments <input checked="" type="checkbox"/> Trail..... <input type="checkbox"/> Armor Coat <input checked="" type="checkbox"/> Drainage Structures <input type="checkbox"/> Fencing <input type="checkbox"/> Asphalt <input checked="" type="checkbox"/> Erosion Control <input checked="" type="checkbox"/> Sidewalks						
Bridge To Remain In Place:	Roadway Width	Length Type				
New Bridge:	Roadway Width	Length Type				
Box Culvert:	Span Rise	Length Type				
Culvert:	Diameter	Length Type				
Bridges and Culverts Sized	<input type="checkbox"/> Yes <input checked="" type="checkbox"/> N/A <input type="checkbox"/> Hydraulic Analysis Pending					
OTHER CONSTRUCTION FEATURES: <p style="text-align: center;">Proposed: Nebraska Games & Park Recreational Trail Grant (50%)</p> <p style="text-align: center;">Proposed: Lower Loup NRD (15%)</p>						
ESTIMATED COST (In Thousands) *OPTIONAL	*COUNTY	*CITY	*STATE	*FEDERAL	*OTHER	TOTAL
		175	250		75	500
PROJECT LENGTH (Nearest Tenth, State Unit of Measure) 1.0 Miles				Project No.: M211(324)		
Signature: <i>Richard J. Begus</i>				Title: City Engineer		Date: August 14, 2023

BOARD OF PUBLIC ROADS CLASSIFICATIONS AND STANDARDS
FORM 7 ONE-AND SIX-YEAR PLAN
HIGHWAY OR STREET IMPROVEMENT PROJECT

County PLATTE	City: COLUMBUS	Village:
Location Description: <p style="text-align: center;">23 Street From 32 Avenue to East of East 11 Avenue</p>		
EXISTING SURFACE TYPE AND STRUCTURES: (Such As Dirt, Gravel, Asphalt, Concrete, Culvert Or Bridge) <p style="text-align: center;">Asphalt over Concrete</p>		
Average Daily Traffic: 2023 = <u>23,730</u> , 2043 = <u>40,000</u>	Classification Type: (As Shown On Functional Classification Map) <p style="text-align: center;">Expressway</p>	
Proposed Improvement		
Design Standard Number: Highway	Surfacing Concrete	Thickness TBD
		Width 60' Plus
<input checked="" type="checkbox"/> Grading	<input checked="" type="checkbox"/> Concrete	<input checked="" type="checkbox"/> Right Of Way
<input type="checkbox"/> Aggregate	<input checked="" type="checkbox"/> Curb & Gutter	<input checked="" type="checkbox"/> Utility Adjustments
<input type="checkbox"/> Armor Coat	<input checked="" type="checkbox"/> Drainage Structures	<input type="checkbox"/> Fencing
<input type="checkbox"/> Asphalt	<input checked="" type="checkbox"/> Erosion Control	<input checked="" type="checkbox"/> Sidewalks
		<input checked="" type="checkbox"/> Lighting
		<input checked="" type="checkbox"/> Traffic Signals
Bridge To Remain In Place:	Roadway Width	Length
		Type
New Bridge:	Roadway Width	Length
		Type
Box Culvert:	Span	Rise
		Length
		Type
Culvert:	Diameter	Length
		Type
Bridges and Culverts Sized	<input type="checkbox"/> Yes <input checked="" type="checkbox"/> N/A <input type="checkbox"/> Hydraulic Analysis Pending	
OTHER CONSTRUCTION FEATURES: NDOT Project – State and City funds. Sidewalk replacement, traffic signal replacement, Partial access elimination property acquisition		
ESTIMATED COST (In Thousands) *OPTIONAL	*COUNTY	*CITY
		10,800
		21,200
		32,000
PROJECT LENGTH (Nearest Tenth, State Unit of Measure) 2.7 Miles	Project No.: M211(325)	
Signature: 	Title: City Engineer	Date: August 14, 2023

BOARD OF PUBLIC ROADS CLASSIFICATIONS AND STANDARDS
FORM 7 ONE-AND SIX-YEAR PLAN
HIGHWAY OR STREET IMPROVEMENT PROJECT

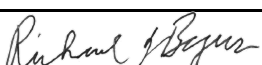
County PLATTE	City: COLUMBUS	Village:				
Location Description: <p style="text-align: center;">Riverside 3rd Addition</p>						
EXISTING SURFACE TYPE AND STRUCTURES: (Such As Dirt, Gravel, Asphalt, Concrete, Culvert Or Bridge) <p style="text-align: center;">Undeveloped Land</p>						
Average Daily Traffic: 2023 = <u>0</u> 0 2043 = <u>100</u>		Classification Type: (As Shown On Functional Classification Map) <p style="text-align: center;">Local</p>				
Proposed Improvement						
Design Standard Number: <p style="text-align: center;">Municipal</p>		Surfacing <p style="text-align: center;">Concrete</p>	Thickness <p style="text-align: center;">6"</p>	Width <p style="text-align: center;">33'</p>		
<input checked="" type="checkbox"/> Grading	<input checked="" type="checkbox"/> Concrete	<input type="checkbox"/> Right Of Way	<input checked="" type="checkbox"/> Lighting			
<input type="checkbox"/> Aggregate	<input checked="" type="checkbox"/> Curb & Gutter	<input type="checkbox"/> Utility Adjustments	<input type="checkbox"/>			
<input type="checkbox"/> Armor Coat	<input checked="" type="checkbox"/> Drainage Structures	<input type="checkbox"/> Fencing			
<input type="checkbox"/> Asphalt	<input type="checkbox"/> Erosion Control	<input type="checkbox"/> Sidewalks			
Bridge To Remain In Place:	Roadway Width	Length		Type		
New Bridge:	Roadway Width	Length		Type		
Box Culvert:	Span	Rise	Length		Type	
Culvert:	Diameter	Length			Type	
Bridges and Culverts Sized	<input type="checkbox"/> Yes <input checked="" type="checkbox"/> N/A <input type="checkbox"/> Hydraulic Analysis Pending					
OTHER CONSTRUCTION FEATURES: <p style="text-align: center;">Private development. Roads turned over to city.</p>						
ESTIMATED COST (In Thousands) *OPTIONAL	*COUNTY	*CITY	*STATE	*FEDERAL	*OTHER	TOTAL
					125	125
PROJECT LENGTH (Nearest Tenth, State Unit of Measure) <p style="text-align: center;">0.1 Miles</p>				Project No.: <p style="text-align: center;">M211(346)</p>		
Signature: 			Title: City Engineer		Date: August 14, 2023	

BOARD OF PUBLIC ROADS CLASSIFICATIONS AND STANDARDS
FORM 7 ONE-AND SIX-YEAR PLAN
HIGHWAY OR STREET IMPROVEMENT PROJECT

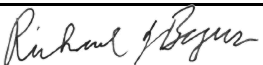
County PLATTE	City: COLUMBUS	Village:				
Location Description: <p style="text-align: center;">23rd Street / Shady Lake Road from 54th Avenue to West Corporate Limits</p> <p style="text-align: center;">SID #188</p>						
EXISTING SURFACE TYPE AND STRUCTURES: (Such As Dirt, Gravel, Asphalt, Concrete, Culvert Or Bridge) <p style="text-align: center;">24' Rural Asphalt</p>						
Average Daily Traffic: 2023 = <u>1,360</u> 0 2043 = <u>2,500</u>		Classification Type: (As Shown On Functional Classification Map) <p style="text-align: center;">Arterial</p>				
Proposed Improvement						
Design Standard Number: Municipal		Surfacing Concrete	Thickness 9"	Width 41'		
<input checked="" type="checkbox"/> Grading	<input checked="" type="checkbox"/> Concrete	<input type="checkbox"/> Right Of Way	<input checked="" type="checkbox"/> Lighting			
<input type="checkbox"/> Aggregate	<input checked="" type="checkbox"/> Curb & Gutter	<input type="checkbox"/> Utility Adjustments	<input type="checkbox"/>			
<input type="checkbox"/> Armor Coat	<input checked="" type="checkbox"/> Drainage Structures	<input type="checkbox"/> Fencing				
<input type="checkbox"/> Asphalt	<input type="checkbox"/> Erosion Control	<input checked="" type="checkbox"/> Sidewalks				
Bridge To Remain In Place:	Roadway Width	Length	Type			
New Bridge:	Roadway Width	Length	Type			
Box Culvert:	Span	Rise	Length	Type		
Culvert:	Diameter	Length	Type			
Bridges and Culverts Sized	<input type="checkbox"/> Yes <input checked="" type="checkbox"/> N/A <input type="checkbox"/> Hydraulic Analysis Pending					
OTHER CONSTRUCTION FEATURES: <p style="text-align: center;">Federal Funds Purchase Program Assessments</p>						
ESTIMATED COST (In Thousands) *OPTIONAL	*COUNTY	*CITY	*STATE	*FEDERAL	*OTHER	TOTAL
		3,450				3,450
PROJECT LENGTH (Nearest Tenth, State Unit of Measure) 0.6 Miles				Project No.:M211(352)		
Signature: 			Title: City Engineer		Date: August 14, 2023	

BOARD OF PUBLIC ROADS CLASSIFICATIONS AND STANDARDS
FORM 7 ONE-AND SIX-YEAR PLAN
HIGHWAY OR STREET IMPROVEMENT PROJECT

County PLATTE	City: COLUMBUS	Village:				
Location Description: <p style="text-align: center;">Downtown Evaluation UPRR Separation Study</p>						
EXISTING SURFACE TYPE AND STRUCTURES: (Such As Dirt, Gravel, Asphalt, Concrete, Culvert Or Bridge) <p style="text-align: center;">At grade crossings at 23rd Avenue and 26th Avenue</p>						
Average Daily Traffic: 2023 = <u>NA</u> 0 2043 = <u>NA</u>	Classification Type: (As Shown On Functional Classification Map)					
Proposed Improvement						
Design Standard Number: Municipal	Surfacing Concrete	Thickness 6"				
		Width 33'				
<input type="checkbox"/> Grading <input type="checkbox"/> Concrete <input type="checkbox"/> Right Of Way <input type="checkbox"/> Lighting <input type="checkbox"/> Aggregate <input type="checkbox"/> Curb & Gutter <input type="checkbox"/> Utility Adjustments <input checked="" type="checkbox"/> Study <input type="checkbox"/> Armor Coat <input type="checkbox"/> Drainage Structures <input type="checkbox"/> Fencing <input type="checkbox"/> Asphalt <input type="checkbox"/> Erosion Control <input type="checkbox"/> Sidewalks						
Bridge To Remain In Place:	Roadway Width	Length	Type			
New Bridge:	Roadway Width	Length	Type			
Box Culvert:	Span	Rise	Length	Type		
Culvert:	Diameter	Length	Type			
Bridges and Culverts Sized	<input type="checkbox"/> Yes <input checked="" type="checkbox"/> N/A <input type="checkbox"/> Hydraulic Analysis Pending					
OTHER CONSTRUCTION FEATURES: <p style="text-align: center;">UPRR Tracks</p>						
ESTIMATED COST (In Thousands) *OPTIONAL	*COUNTY	*CITY	*STATE	*FEDERAL	*OTHER	TOTAL
		275				275
PROJECT LENGTH (Nearest Tenth, State Unit of Measure)				Project No.:		
				M211(355)		
Signature: <i>Richard J. Boyer</i>				Title: City Engineer		Date: August 14, 2023

BOARD OF PUBLIC ROADS CLASSIFICATIONS AND STANDARDS
FORM 7 ONE-AND SIX-YEAR PLAN
HIGHWAY OR STREET IMPROVEMENT PROJECT

County PLATTE	City: COLUMBUS	Village:				
Location Description: <p style="text-align: center;">63rd Avenue Howard Boulevard to Lost Creek Parkway (Private Development)</p>						
EXISTING SURFACE TYPE AND STRUCTURES: (Such As Dirt, Gravel, Asphalt, Concrete, Culvert Or Bridge) <p style="text-align: center;">Gravel</p>						
Average Daily Traffic: 2023 = _____ 0 2043 = _____	Classification Type: (As Shown On Functional Classification Map) <p style="text-align: center;">Collector</p>					
Proposed Improvement						
Design Standard Number: <p style="text-align: center;">Municipal</p>	Surfacing <p style="text-align: center;">Concrete</p>	Thickness <p style="text-align: center;">9"</p>				
		Width <p style="text-align: center;">41'</p>				
<input checked="" type="checkbox"/> Grading <input checked="" type="checkbox"/> Concrete <input type="checkbox"/> Right Of Way <input checked="" type="checkbox"/> Lighting <input type="checkbox"/> Aggregate <input checked="" type="checkbox"/> Curb & Gutter <input checked="" type="checkbox"/> Utility Adjustments <input type="checkbox"/> Study <input type="checkbox"/> Armor Coat <input checked="" type="checkbox"/> Drainage Structures <input type="checkbox"/> Fencing <input type="checkbox"/> Asphalt <input type="checkbox"/> Erosion Control <input checked="" type="checkbox"/> Sidewalks						
Bridge To Remain In Place:	Roadway Width	Length	Type			
New Bridge:	Roadway Width	Length	Type			
Box Culvert:	Span	Rise	Length	Type		
Culvert:	Diameter	Length	Type			
Bridges and Culverts Sized	<input type="checkbox"/> Yes <input checked="" type="checkbox"/> N/A <input type="checkbox"/> Hydraulic Analysis Pending					
OTHER CONSTRUCTION FEATURES:						
ESTIMATED COST (In Thousands) *OPTIONAL	*COUNTY	*CITY	*STATE	*FEDERAL	*OTHER	TOTAL
					2,500	2,500
PROJECT LENGTH (Nearest Tenth, State Unit of Measure) <p style="text-align: center;">0.5 Miles</p>				Project No.: <p style="text-align: center;">M211(357)</p>		
Signature: <i>Richard J. Begus</i>				Title: City Engineer		Date: August 14, 2023

BOARD OF PUBLIC ROADS CLASSIFICATIONS AND STANDARDS
FORM 7 ONE-AND SIX-YEAR PLAN
HIGHWAY OR STREET IMPROVEMENT PROJECT

County PLATTE	City: COLUMBUS	Village:				
Location Description: <p style="text-align: center;">East Park / 17th Street from 16th to 18th Avenues</p> <p style="text-align: center;">Storm Sewer</p>						
EXISTING SURFACE TYPE AND STRUCTURES: (Such As Dirt, Gravel, Asphalt, Concrete, Culvert Or Bridge) <p style="text-align: center;">Concrete</p>						
Average Daily Traffic: 2023 = <u>NA</u> 0 2043 = <u>NA</u>	Classification Type: (As Shown On Functional Classification Map) <p style="text-align: center;">Collector</p>					
Proposed Improvement						
Design Standard Number: Municipal	Surfacing	Thickness				
		Width				
<input type="checkbox"/> Grading <input type="checkbox"/> Concrete <input type="checkbox"/> Right Of Way <input type="checkbox"/> Lighting <input type="checkbox"/> Aggregate <input type="checkbox"/> Curb & Gutter <input type="checkbox"/> Utility Adjustments <input type="checkbox"/> Study <input type="checkbox"/> Armor Coat <input checked="" type="checkbox"/> Drainage Structures <input type="checkbox"/> Fencing <input type="checkbox"/> Asphalt <input type="checkbox"/> Erosion Control <input type="checkbox"/> Sidewalks						
Bridge To Remain In Place:	Roadway Width	Length	Type			
New Bridge:	Roadway Width	Length	Type			
Box Culvert:	Span	Rise	Length	Type		
Culvert:	Diameter	Length	Type			
Bridges and Culverts Sized	<input type="checkbox"/> Yes <input checked="" type="checkbox"/> N/A <input type="checkbox"/> Hydraulic Analysis Pending					
OTHER CONSTRUCTION FEATURES: <p style="text-align: center;">Storm Sewer improvements from East Park Rain Garden to 17th Street to 16th Avenue</p>						
ESTIMATED COST (In Thousands) *OPTIONAL	*COUNTY	*CITY	*STATE	*FEDERAL	*OTHER	TOTAL
		350				350
PROJECT LENGTH (Nearest Tenth, State Unit of Measure) 0.2 Miles				Project No.: M211(358)		
Signature: <i>Richard J. Boyer</i>				Title: City Engineer		Date: August 14, 2023

BOARD OF PUBLIC ROADS CLASSIFICATIONS AND STANDARDS
FORM 7 ONE-AND SIX-YEAR PLAN
HIGHWAY OR STREET IMPROVEMENT PROJECT

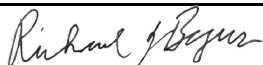
County PLATTE	City: COLUMBUS	Village:				
Location Description: <p style="text-align: center;">Signal Upgrades 27th Street & 33rd Avenue</p>						
EXISTING SURFACE TYPE AND STRUCTURES: (Such As Dirt, Gravel, Asphalt, Concrete, Culvert Or Bridge)						
Average Daily Traffic: 2023 = <u>9,000</u> 0 2043 = <u>11,500</u>		Classification Type: (As Shown On Functional Classification Map) <p style="text-align: center;">Arterial</p>				
Proposed Improvement						
Design Standard Number: Municipal		Surfacing	Thickness	Width		
<input type="checkbox"/> Grading	<input type="checkbox"/> Concrete	<input type="checkbox"/> Right Of Way	<input type="checkbox"/> Lighting			
<input type="checkbox"/> Aggregate	<input type="checkbox"/> Curb & Gutter	<input type="checkbox"/> Utility Adjustments	<input type="checkbox"/> Study			
<input type="checkbox"/> Armor Coat	<input type="checkbox"/> Drainage Structures	<input type="checkbox"/> Fencing	<input checked="" type="checkbox"/> Traffic Signal			
<input type="checkbox"/> Asphalt	<input type="checkbox"/> Erosion Control	<input type="checkbox"/> Sidewalks				
Bridge To Remain In Place:	Roadway Width	Length	Type			
New Bridge:	Roadway Width	Length	Type			
Box Culvert:	Span	Rise	Length	Type		
Culvert:	Diameter	Length	Type			
Bridges and Culverts Sized	<input type="checkbox"/> Yes <input checked="" type="checkbox"/> N/A <input type="checkbox"/> Hydraulic Analysis Pending					
OTHER CONSTRUCTION FEATURES: <p style="text-align: center;">Existing Signal Upgrades</p>						
ESTIMATED COST (In Thousands) *OPTIONAL	*COUNTY	*CITY	*STATE	*FEDERAL	*OTHER	TOTAL
		100				100
PROJECT LENGTH (Nearest Tenth, State Unit of Measure)				Project No.:		
				M211(359)		
Signature: 			Title: City Engineer		Date: August 14, 2023	

BOARD OF PUBLIC ROADS CLASSIFICATIONS AND STANDARDS
FORM 7 ONE-AND SIX-YEAR PLAN
HIGHWAY OR STREET IMPROVEMENT PROJECT

County PLATTE	City: COLUMBUS	Village:
Location Description: <p style="text-align: center;">Signal Upgrades</p> <p style="text-align: center;">Wilderness Road and Lost Creek Parkway</p>		
EXISTING SURFACE TYPE AND STRUCTURES: (Such As Dirt, Gravel, Asphalt, Concrete, Culvert Or Bridge)		
Average Daily Traffic: 2023 = <u>7,000</u> 0 2043 = <u>10,200</u>		Classification Type: (As Shown On Functional Classification Map) Major Arterial
Proposed Improvement		
Design Standard Number: Municipal	Surfacing	Thickness
<input type="checkbox"/> Grading <input type="checkbox"/> Concrete <input type="checkbox"/> Right Of Way <input type="checkbox"/> Lighting <input type="checkbox"/> Aggregate <input type="checkbox"/> Curb & Gutter <input type="checkbox"/> Utility Adjustments <input type="checkbox"/> Study <input type="checkbox"/> Armor Coat <input type="checkbox"/> Drainage Structures <input type="checkbox"/> Fencing <input checked="" type="checkbox"/> Traffic Signal <input type="checkbox"/> Asphalt <input type="checkbox"/> Erosion Control <input type="checkbox"/> Sidewalks		
Bridge To Remain In Place:	Roadway Width	Length
New Bridge:	Roadway Width	Length
Box Culvert:	Span	Rise
Culvert:	Diameter	Length
Bridges and Culverts Sized	<input type="checkbox"/> Yes <input checked="" type="checkbox"/> N/A <input type="checkbox"/> Hydraulic Analysis Pending	
OTHER CONSTRUCTION FEATURES: <p style="text-align: center;">Existing Signal Upgrades</p>		
ESTIMATED COST (In Thousands) *OPTIONAL	*COUNTY	*CITY
		100
PROJECT LENGTH (Nearest Tenth, State Unit of Measure)		Project No.: M211(360)
Signature: 	Title: City Engineer	Date: August 14, 2023

BOARD OF PUBLIC ROADS CLASSIFICATIONS AND STANDARDS
FORM 7 ONE-AND SIX-YEAR PLAN
HIGHWAY OR STREET IMPROVEMENT PROJECT

County PLATTE	City: COLUMBUS	Village:				
Location Description: <p style="text-align: center;">Private Development – Centennial Park 8th Addition</p> <p style="text-align: center;">2nd Street from 3rd to 7th Avenues; 5th Avenue from 2nd Street north and south 200' and</p> <p style="text-align: center;">6th Avenue from 2nd Street south 200'</p>						
EXISTING SURFACE TYPE AND STRUCTURES: (Such As Dirt, Gravel, Asphalt, Concrete, Culvert Or Bridge) <p style="text-align: center;">Undeveloped Land</p>						
Average Daily Traffic: 2023 = <u>200</u> 0 2043 = <u>400</u>	Classification Type: (As Shown On Functional Classification Map) <p style="text-align: center;">Local</p>					
Proposed Improvement						
Design Standard Number: Municipal	Surfacing Concrete	Thickness 6"				
		Width 33'				
<input checked="" type="checkbox"/> Grading <input checked="" type="checkbox"/> Concrete <input type="checkbox"/> Right Of Way <input checked="" type="checkbox"/> Lighting <input type="checkbox"/> Aggregate <input checked="" type="checkbox"/> Curb & Gutter <input type="checkbox"/> Utility Adjustments <input type="checkbox"/> Study <input type="checkbox"/> Armor Coat <input checked="" type="checkbox"/> Drainage Structures <input type="checkbox"/> Fencing <input type="checkbox"/> Asphalt <input type="checkbox"/> Erosion Control <input checked="" type="checkbox"/> Sidewalks						
Bridge To Remain In Place:	Roadway Width	Length	Type			
New Bridge:	Roadway Width	Length	Type			
Box Culvert:	Span	Rise	Length	Type		
Culvert:	Diameter	Length	Type			
Bridges and Culverts Sized	<input type="checkbox"/> Yes <input checked="" type="checkbox"/> N/A <input type="checkbox"/> Hydraulic Analysis Pending					
OTHER CONSTRUCTION FEATURES: 						
ESTIMATED COST (In Thousands) *OPTIONAL	*COUNTY	*CITY	*STATE	*FEDERAL	*OTHER	TOTAL
					350	350
PROJECT LENGTH (Nearest Tenth, State Unit of Measure) 0.4 Miles				Project No.: M211(362)		
Signature: <i>Richard J. Boyer</i>				Title: City Engineer		Date: August 14, 2023

BOARD OF PUBLIC ROADS CLASSIFICATIONS AND STANDARDS
FORM 7 ONE-AND SIX-YEAR PLAN
HIGHWAY OR STREET IMPROVEMENT PROJECT

County PLATTE	City: COLUMBUS	Village:
Location Description: <p style="text-align: center;">Park Place 10th Addition, Private Developer Subdivision</p>		
EXISTING SURFACE TYPE AND STRUCTURES: (Such As Dirt, Gravel, Asphalt, Concrete, Culvert Or Bridge)		
Average Daily Traffic: 2023 = <u> 0 </u> 2043 = <u> 150 </u>	Classification Type: (As Shown On Functional Classification Map) <p style="text-align: center;">Arterial</p>	
Proposed Improvement		
Design Standard Number: <p style="text-align: center;">Municipal</p>	Surfacing <p style="text-align: center;">Concrete</p>	Thickness <p style="text-align: center;">9"</p>
Width <p style="text-align: center;">41'</p>		
<input checked="" type="checkbox"/> Grading	<input checked="" type="checkbox"/> Concrete	<input type="checkbox"/> Right Of Way
<input type="checkbox"/> Aggregate	<input checked="" type="checkbox"/> Curb & Gutter	<input type="checkbox"/> Utility Adjustments
<input type="checkbox"/> Armor Coat	<input checked="" type="checkbox"/> Drainage Structures	<input type="checkbox"/> Fencing
<input type="checkbox"/> Asphalt	<input checked="" type="checkbox"/> Erosion Control	<input checked="" type="checkbox"/> Sidewalks
<input checked="" type="checkbox"/> Lighting	<input type="checkbox"/> Trails	
Bridge To Remain In Place:	Roadway Width	Length
		Type
New Bridge:	Roadway Width	Length
		Type
Box Culvert:	Span	Rise
		Length
		Type
Culvert:	Diameter	Length
		Type
Bridges and Culverts Sized	<input type="checkbox"/> Yes <input checked="" type="checkbox"/> N/A <input type="checkbox"/> Hydraulic Analysis Pending	
OTHER CONSTRUCTION FEATURES:		
ESTIMATED COST		
(In Thousands)	*COUNTY	*CITY
*OPTIONAL		
	*STATE	*FEDERAL
	*OTHER	TOTAL
	225	225
PROJECT LENGTH (Nearest Tenth, State Unit of Measure) <p style="text-align: center;">0.2 Miles</p>	Project No.: <p style="text-align: center;">M211(366)</p>	
Signature: 	Title: <p style="text-align: center;">City Engineer</p>	Date: <p style="text-align: center;">August 14, 2023</p>

8. PETITIONS AND COMMUNICATIONS - None

9. REPORTS OF CITY OFFICES

9.A. Update on Nebraska Department of Transportation 23rd Street Reconstruction Project.

COLUMBUS 23RD STREET MONTHLY PROGRESS REPORT

AUGUST 2023

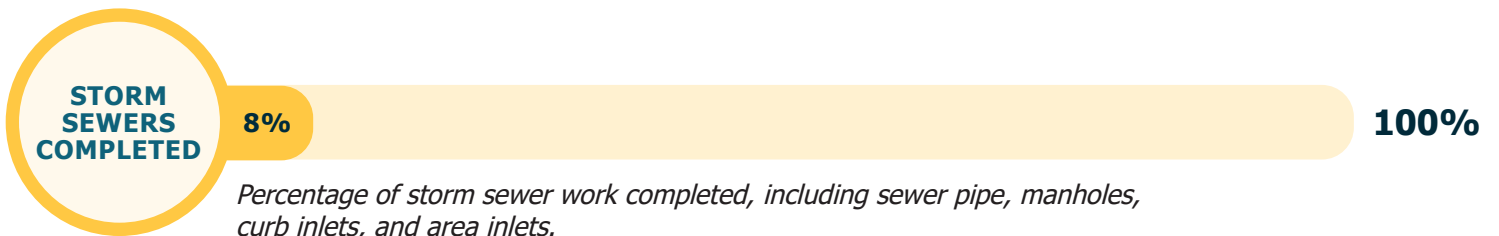
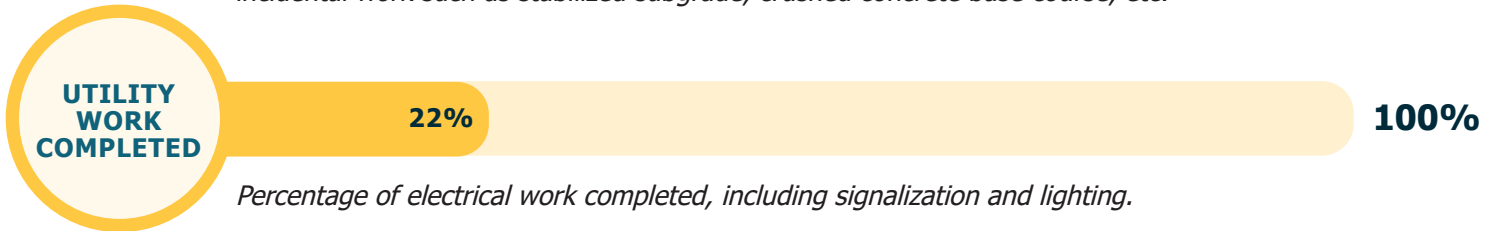
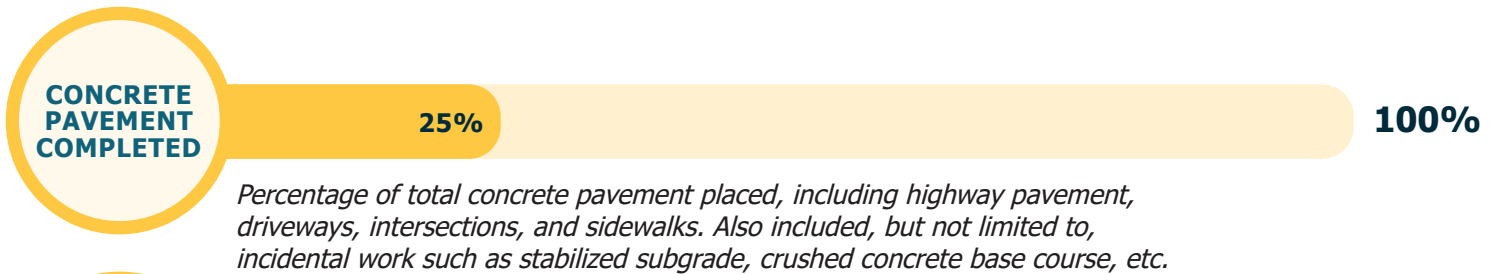
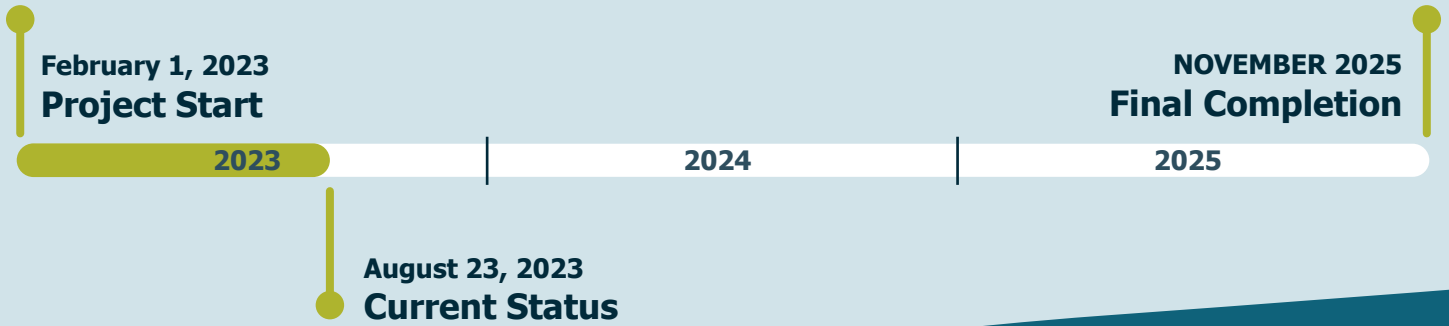

COLUMBUS 23RD STREET CONSTRUCTION SCHEDULE

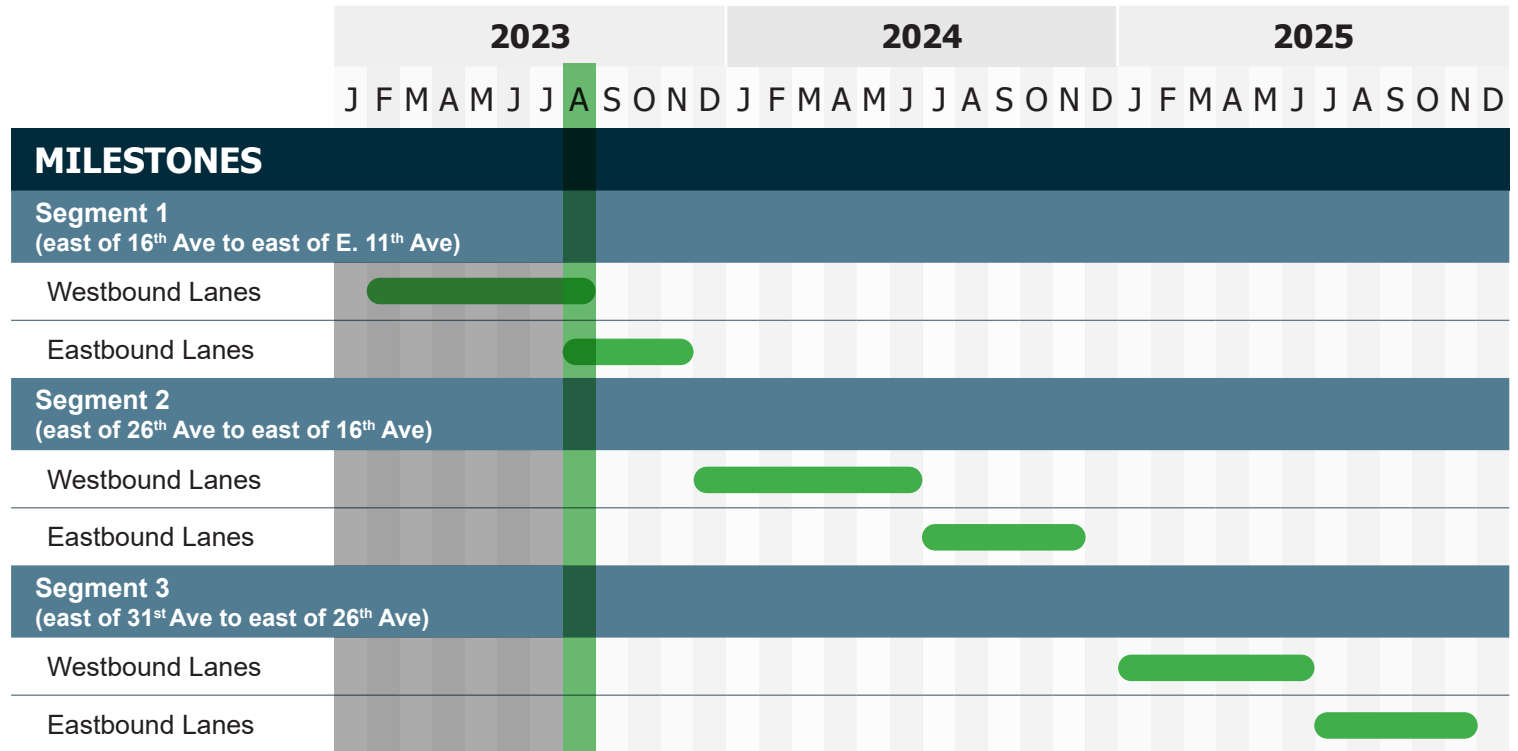

Phase Legend (horizontal lines):

- On or ahead of schedule
- Less than or equal to 1 month behind schedule
- More than 1 month behind
- Complete

Project Progress Bar Legend (vertical line):

- On or ahead of schedule
- Less than or equal to 1 month behind schedule
- More than 1 month behind schedule

PAST TRAFFIC CHANGES

- Shifted traffic from existing eastbound lanes to newly constructed westbound lanes

ANTICIPATED TRAFFIC CHANGES

Temporary closures*:

- 14th AVE
- 10th AVE
- 8th AVE
- 3rd AVE
- East 3rd AVE
- East 11th AVE

* These traffic changes are weather dependent
Visit NDOT.INFO/32234 for more information.

ALTERNATE ROUTES

- 48th AVE, Lost Creek Parkway & East 6th AVE to the north
- 8th ST and 3rd AVE to the south (no trucks permitted on this route)



10. REPORTS OF COUNCIL COMMITTEES

10.A.COMMITTEE OF THE WHOLE - August 21, 2023

COMMITTEE OF THE WHOLE
August 21, 2023

A meeting of the Committee of the Whole of the City of Columbus, Nebraska, was convened in open and public session on August 21, 2023, at 5 p.m. in the Columbus Community Building, Community Room, 2500 14 Street, Columbus, Nebraska.

Notice of this meeting was given in advance thereof by publication in the Columbus Telegram on August 17, 2023, with a copy of the proof of publication being on file in the office of the city clerk. Availability of the agenda was communicated in the advance notice and in the notice to the mayor and members of the city council of this meeting. All proceedings hereafter shown were taken while the convened meeting was open to the public.

1. **Statement of compliance with Open Meetings Act and roll call:** Council President Augustine-Schulte announced that a copy of the Open Meetings Act is posted in the meeting room. Present were Council Members Beth Augustine-Schulte, Charlie Bahr, Hope Freshour, Troy Hiemer, Rich Jablonski, and Prent Roth. Council Members Kat Lopez and Ron Schilling were absent and excused. Also present was Mayor James Bulkley. City staff members included City Administrator Tara Vasicek, City Clerk Janelle Kline, City Engineer Rick Bogus, Police Chief Chuck Sherer, Public Works Director Chuck Sliva, Finance Director Heather Lindsley, Communications Director Rachel Pensick, Fire Chief Ryan Gray, Human Resources Director Tammy Orender, Chief Building and Code Inspector Andy Woehrer, Library Director Jeri Hopkins, Park and Recreation Director Betsy Eckhardt, Planning & Economic Development Director Jean Van Iperen, Airport Manager Ross Niedbalski, and Communications Manager Matt Lindberg.
2. **Fiscal Year 2023-2024.**
 - 2.A. **One percent restricted funds authority increase.** It was noted that governments are allowed to increase their base of restricted funds by two and one-half percent and may, with city council approval, increase an additional one percent to serve as a reserve for emergencies that may occur in the future. The additional one percent of restricted funds authority for Fiscal Year 2023-2024 will be \$124,123. A recommendation was made to approve an increase to the Restricted Funds Authority by an additional one percent for Fiscal Year 2023-2024 with a motion by Hiemer and a second by Bahr. Augustine-Schulte, Bahr, Freshour, Hiemer, Jablonski, and Roth voted "Aye" and none voted "Nay". Lopez and Schilling were absent.
 - 2.B. **Fee schedule.** Vasicek reviewed the proposed changes to the fee schedule in detail. A recommendation was made to approve the fee schedule for Fiscal Year 2023-2024 as presented with a motion by Jablonski and a second by Roth. Augustine-Schulte, Bahr, Freshour, Hiemer, Jablonski, and Roth voted

“Aye” and none voted “Nay”. Lopez and Schilling were absent.

2.C. Pay plan. Vasicek noted that the proposed pay plan includes a three percent cost of living adjustment that is based off the Consumer Price Index from June 2023. A recommendation was made to approve the pay plan for Fiscal Year 2023-2024 as presented with a motion by Hiemer and a second by Bahr. Augustine-Schulte, Bahr, Freshour, Hiemer, Jablonski, and Roth voted “Aye” and none voted “Nay”. Lopez and Schilling were absent.

2.D. Capital improvement plan. Vasicek reviewed the capital improvement plan in detail. Roth stated that he is supportive of the capital improvement plan as a whole; however, he will not support the restroom and splash pad at Centennial Park when they are brought forward for approval as he feels there should be a master plan for Centennial Park to determine the proper locations for these items. He also expressed opposition to the electronic billboard unless justification is provided that proves it will be beneficial. A recommendation was made to approve the capital improvement plan for Fiscal Year 2023-2024 as presented with a motion by Bahr and a second by Hiemer. Augustine-Schulte, Bahr, Freshour, Hiemer, Jablonski, and Roth voted “Aye” and none voted “Nay”. Lopez and Schilling were absent.

2.E. Budget. Vasicek pointed out that the budget report included in the packet is complete with the exception of property tax as the property tax valuations were not received until after the packets were put together. She noted that the valuations have since come in and were increased by 13.39 percent. Vasicek recommended the city accept only the allowable increase of 5.27 percent, an increase of \$335,000, which would decrease the city’s property tax levy by 7.16 percent, the lowest in 40 years. She pointed out that the city would be foregoing \$516,000 in property tax revenue and the city’s property tax levy will be reduced to .2926. Vasicek reviewed the budget in detail and noted that sales tax receipts are projected at \$9.25 million, with one percent being used for designated economic development projects and one-half percent for bonds to pay off the fire and police stations as well as the library/cultural arts portion of the new community building. Roth noted that he had various questions regarding the budget and commended city staff for the answers and explanations. A recommendation was made to approve the budget for Fiscal Year 2023-2024 as presented with a motion by Hiemer and a second by Roth. Augustine-Schulte, Bahr, Freshour, Hiemer, Jablonski, and Roth voted “Aye” and none voted “Nay”. Lopez and Schilling were absent.

5. Adjournment: The meeting adjourned at 5:40 p.m.

OFFICE OF THE CITY CLERK

:Janelle Kline

10.A.1. Fiscal Year 2023-2024.

10.A.1.a. One percent restricted funds authority increase.



MEMORANDUM

DATE: August 7, 2023
TO: Tara Vasicek, City Administrator 
FROM: Heather Lindsley, Finance Director
SUBJECT: One (1%) Percent Increase in Restricted Funds Authority

Staff recommends the City Council approve an increase in the Restricted Funds Authority by an additional one (1.0%) percent, as allowed by state statute.

For municipalities, restricted funds are property taxes, payments in lieu of property tax, sales tax, motor vehicle tax, and all types of state aid including highway allocations, motor vehicle fees, and municipal equalization aid. All governments are allowed to increase their base of restricted funds by two and one-half (2.5%) percent. As in the past, the Council may increase the base by an additional **one (1.0%) percent to serve as a hedge against an emergency that might occur in the future**. Should the Council desire to increase the base, the Council does not have to spend the additional one percent. However, it does keep this taxing authority available for unforeseen events in the future. An affirmative vote of seventy-five percent (75%) of the members of the governing body constituting a quorum authorized to conduct business, is required for passage.

For the 2022-2023 Budget the one percent of restricted funds authority was \$119,926 and the comparable number for 2023-2024 will be \$124,123. Primarily the unused restricted funds authority goes up and down depending on how much of the budgeted capital improvements are improvements to real property, which are a lid exception.

Approving the additional one percent increases the City of Columbus' unused restricted funds authority, which is carried forward from year to year. This allows future Councils more flexibility to deal with emergency funding issues for the City.

10.A.1.b. Fee schedule

**SCHEDULE OF FEES
2022 – 2023
INDEX**

**ALL FEES MAY BE MODIFIED AT THE DISCRETION OF THE CITY
ADMINISTRATOR FOR PURPOSES OF PROMOTING CITY ACTIVITIES.
All required insurance certificates shall name city as additional insured.**

AIRPORT	1
AQUATICS	
Aquatic Center	2
Pawnee Plunge	4
CEMETERY	6
COLUMBUS AREA TRANSIT	7
<u>COMMUNITY CENTER SENIOR CENTER</u>	8
COMMUNITY DEVELOPMENT	9
ECONOMIC DEVELOPMENT	16
ENGINEERING	17
FIRE	18
GENERAL ADMINISTRATION	22
GOLF COURSE	
Quail Run	23
Van Berg	25
LIBRARY	27
PARKS AND RECREATION	28
POLICE	33
Animal Control	35
PUBLIC WORKS	
Streets	36
Transfer Station	38
Water/Sewer Utilities	40

AIRPORT

Rent per Month

Hangar 1412N	\$115.00	\$125
Hangar 1412S	\$105.00	\$115
Hangar 1406W	\$220.00	\$240
Hangar 1406E	*\$220.00	\$240
Hangar 1230	\$45.00	\$45
Hangar 1240	\$85.00	\$95
Hangar 1315	\$180.00	\$200
Hangar 1508	\$90.00	\$100
Hangar 1508 Storage Units	\$45.00	\$55
Hangar 1412W	\$260.00	\$280
Hangar 1412E	**\$260.00	\$280
Hangar 1334	**\$690.00	\$750
Hangar 1340	**\$630.00	\$690
Hangar 1307	**\$175.00	\$185
Hangar 1430	**\$365.00	\$400
Land Lease/Non-Airport Owned Hangars	**\$.27	.30 per sq. ft.
Aerial Applicator Agreement		\$2,000.00 per year
Flowage	*\$.07	.10 per gallon
Fuel Storage	*\$.10	.12 per gallon
T -Hangar waiting list:		
Administrative Fee (non-refundable)		\$25.00
Deposit (refundable if removed from list or will be applied to first month hangar rent).		\$100.00

*Applicable Upon Lease Renewal

**Except for Current Leases

AQUATICS

The Public Property Director shall establish recreation program fees for miscellaneous sales, programming, special events, and promotion.

AQUATIC CENTER

Daily Admission

Individual \$5

Annual Membership

Individual \$125

Group (Maximum of 6) \$600

Monthly Pass

Individual \$35

Combo Membership (Aquatic Center & Pawnee Plunge)

Individual \$175

Group (Maximum of 6) \$800

Group Swimming Lesson

Parent/Child \$45

Preschool \$45

Grades 1 through 6 \$60

Private Swimming Lesson \$150

Programs

(Low Intensity Aerobics, High Intensity Aerobics, Zumba, Aqualaties, H2O)

50 Punches \$100

25 Punches \$75

10 Punches \$35

5 Punches \$20

Day Pass \$5

Locker Rentals – Annual \$50

Private Rental \$100/hr.

Business Rate

Aquatic Therapy \$75 per 15 minutes

*Requires agreement.

Party Rental

Swimmers will pay daily admission or use membership card.

Party Room	\$60
Toy Rentals (Torpedoes & Goggles require deposit)	FREE

Concessionaire/Vending

Daily Fee	\$16
-----------	------

Water Park Lifeguard Class

Full Class (5 student minimum)	\$175
Review Class – incl. CPR review (5 student minimum)	\$125

CPR for Professional Rescuer and Health Care Provider

Full Class (5 student minimum)	\$100
Review Class (5 student minimum)	\$75

Class Materials

Manual	\$50
Mask (first mask is included in the full Water Park class)	\$25
Certification Card	\$5

Staff Uniforms

Tankini	\$25
Female Guard Suit	\$20
Female Non-Guard Suit	\$20
Male Swim Trunks	\$20
Aquatic Center T-Shirt	\$5
Lanyard	\$1
Whistle	\$1

PAWNEE PLUNGE WATER PARK

Daily Admission

3 yrs. & Under	Free
4 yrs. & Up	\$10 (Incl
both open sessions: 12 Noon – 5 p.m. and 6:30 p.m.-8:30 p.m.)	
10 Person Group	\$70
5 Person Group	\$40
Non-Swimmer (not swimming and not dressed to swim)	\$3
Flow Rider	\$3
Evenings 6:30 p.m. – 8:30 p.m. Monday through Thursday	\$4
Fitness Times	\$5 Non-Member
	No Charge for Pawnee
	Plunge or Aquatic Center
	Pass Holders

Season Pass

Individual	\$125
Household Group up to 6 people (Must reside in same household)	\$400
Each addl person in same household (can include one caregiver)	\$60
Non-Household Group (Maximum of 6)	\$600

Flow Rider Bracelet

(In addition to daily/season/combo pass)	\$3
--	-----

Combo Membership (Aquatic Center & Pawnee Plunge)

Individual	\$175
Household Group up to 6 people (Must reside in the same household)	\$600
Each addl person in same household (can include one caregiver)	\$90
Non-Household Group (Maximum of 6)	\$800

Punch Cards

50 Punches	\$200
25 Punches	\$125

Facility Rental

Exclusive Use – Before or After Public Hours	\$ 500/hr.
(Public Hours are 12:00 p.m. – 8:00 p.m.)	

Reservations will be required with deposit of \$500. Deposit will be applied toward total rate. Cancellations must be received twenty four hours in advance or deposit will not be refunded.

Party Room	\$60
Monday - Thursday, 12:30 p.m. – 4 p.m.	
Friday – Sunday, 12:00 Noon – 3:30 p.m. or 3:30 p.m. – 7 p.m.	
Flow Rider (1 Office, 1 Lifeguard, 1 Supervisor)	\$75/hr.
Lap Pool (1 Office, 3 Lifeguards, 1 Supervisor)	\$150/hr.
Pawnee Plunge (1 Office, 4 Slides, 14 Lifeguards, 1 Supervisor)	\$500/hr.

Staff Uniforms

Tankini	\$25
Female Guard Suit	\$20
Female Non-Guard Suit	\$20
Male Swim Trunks	\$20
Pawnee Plunge T-Shirt	\$5
Lanyard	\$1
Whistle	\$1

Proposed Special Events

Pawnee Polar Plunge: Saturday, May 13, 2023, 9 a.m.	Fee to be determined
Splash Bash—Weekly Wednesday Evening Themed Activity	Evening admission rate
United Way Duck Derby: Friday, August 10, 2023, 6 p.m.	Free
Flow Rider Competition: Friday, August 10, 2023, 6:30 p.m. (required)	\$10 (pre-registration required)
Fish the River: Saturday, August 11, 2023, 1 p.m. – 4 p.m. license; \$5/youth	\$10/adult w/fishing license
Cardboard Regatta: Saturday, August 11, 2023, 7 p.m. (required)	\$10/boat (pre-registration required)
Puppies in the Plunge: Sunday, August 12, 2023, 6 p.m.	\$10/dog

CEMETERY

Cost of Space	\$600
Grave Opening	\$400
Cost of Space (infant)	\$150
Grave Opening (infant)	\$150
Cost of Space (cremation)	\$350
Grave Opening (cremation)	\$180
Grave Opening (cremation vault)	\$210
Certificate of Ownership Transfer	\$25
Stone Setting	\$30
Saturday Funeral (extra charge)	\$250
Winter Funerals (December through February, extra charge)	\$50
Disinterment (burial)	\$750
Disinterment (cremation)	\$250
Disinterment (infant)	\$250

If traditional spaces are sold back to the City of Columbus the city will purchase for \$200 per space.

If cremation spaces are sold back to the City of Columbus the city will purchase for \$100 per space.

If infant spaces are sold back to the City of Columbus the city will purchase for \$50 per space.

COLUMBUS AREA TRANSIT

Boarding Rates: The boarding rates are determined through review of available funding from the Nebraska Department of Roads, United Way, and City of Columbus Budget. Punch tickets are available at Columbus Area Transit office.

Boarding Punch Cards for Eligible Riders:

Punch Card	Fee
5 punch	\$10
10 punch	\$20
20 punch	\$40

COMMUNITY CENTER SENIOR CENTER

Facility Rental: \$25 per hour

Meals	Cost
Congregate Meal:	
Eligible Diner (60 and older)	\$5 per meal (suggested donation)
Ineligible Diner (Under the age of 60)	\$10 per meal
Take Out Meal:	
Eligible Diner	\$5.50 per meal (suggested donation)
Ineligible Diner	\$10 per meal
Home Delivered Meal:	
Eligible Diner Only	\$6 per meal (suggested donation)

All meals are determined through review of funding provided by Northeast Nebraska Area Agency on Aging and the fiscal budget. Meals for eligible diners are considered a suggested contribution per meal. Meals for ineligible diners are fee-based.

COMMUNITY DEVELOPMENT – BUILDING PERMITS

Building Permit Fees (shall be paid prior to issuance of building permit)

Total Valuation		Fees
\$ 1	to 2,000	\$27.50
2,001	to 25,000	\$27.50 for first \$2,000 plus \$5.50 for each additional \$1,000 or fraction thereof up to and including \$25,000.
25,001	to 50,000	\$154 for first \$25,000 plus \$4.40 for each additional \$1,000 or fraction thereof up to and including \$50,000.
50,001	to 100,000	\$264 for first \$50,000 plus \$3.85 for each additional \$1,000 or fraction thereof up to and including \$100,000.
100,001	to 500,000	\$456.50 for first \$100,000 plus \$2.20 for each additional \$1,000 or fraction thereof up to and including \$500,000.
500,001	and up	\$1,336.50 for first \$500,000 plus \$1.65 for each additional \$1,000 or fraction thereof.
General Contractor Registration		No Fee/Certificate of Insurance \$1,000,000 aggregate
Administrative Fee for Online Applications		\$2
Plan review fee equal to 10 percent of building permit for review under the International Residential Code.		
Plan review fee equal to 25 percent of building permit for review under the International Building Code.		
Fence Permit		\$27.50 \$30
Demolition Permit		\$27.50 \$30
Sign Permit:	0-99 sq. ft.	\$35
	100-199 sq. ft.	\$65
	200-300 sq. ft.	\$120
Mobile Home Set Down Permit		\$100

Fee for work commencing before permit is issued may be double the required permit fee at the discretion of the Building Official. The Building Official may waive requirement for a building permit when structure is temporary in nature or less than one hundred twenty (120) square feet in floor area and has no foundation. There shall be no permit required for re-roofing or re-siding an existing structure.

COMMUNITY DEVELOPMENT – BUILDING MOVING PERMITS & LICENSES

Building Moving Permit	\$50 minimum or 4¢ per square foot of floor area, whichever is greater. (Fee is returned if permit is denied.)
Signs (rezoning, special-use & building moving)	\$17 plus tax
Building Moving Permit (after Building already moved)	\$100
Building Moving Annual License Fee	\$50 \$60
Insurance requirements	\$1,000,000 aggregate

Public Liability Insurance is required naming the City as additional insured which fully protects City or anyone else for damages sustained to person or property, resulting from the moving of any building or parts thereof within City and shall indemnify and save the City harmless from any and all suits, judgments, exactions, executions, and liabilities as to personal injuries or property damage in connection with, or related to, or growing out of any building move.

COMMUNITY DEVELOPMENT – PLUMBING LICENSES & PERMITS

Plumbing Licenses and Exam Fees

Master Plumber:

Registration Fee - Resident ~~\$55.00~~ \$60 per year + Certificate of insurance \$1,000,000 aggregate

Registration Fee - Non-Resident ~~\$55.00~~ \$60 per year + Certificate of insurance \$1,000,000 aggregate

Journeyman Plumber:

Registration Fee – Resident & Non-Resident ~~\$27.50~~ \$30 per year

Apprentice Plumber:

Registration Fee – Resident & Non-Resident ~~\$16.50~~ \$20 per year

Do Your Own Plumbing Registration Fee ~~\$27.50~~ \$30

Licensing – Water Conditioning Contractor ~~\$27.50~~ \$30 per year + Certificate of insurance \$1,000,000 aggregate

– Water Conditioning Installer ~~\$27.50~~ \$30

~~Water Conditioning Exam~~ ~~\$27.50~~

Plumbing Permit Fees (shall be paid prior to issuance of plumbing permit):

Fee for work commencing before permit is issued may be double the required permit fee at the discretion of the Community Development Director.

Plumbing New Residential:

One Bathroom ~~\$77~~–\$80

Each Additional Bathroom ~~\$13~~–\$15

Each Additional 1/2 Bathroom ~~\$11~~–\$13

Plumbing New Commercial opening ~~\$70~~ \$75 plus ~~\$4~~ \$5 for each fixture or trap

Existing Plumbing Remodel & Extensions opening ~~\$12~~ \$15 plus ~~\$4~~ \$5 for each fixture or trap

Sewer & Water Inspections not covered under new residential or commercial permits ~~\$19~~–25

Sprinkler System	\$19 -\$20
Backflow Protective Devices:	\$13 \$15 plus \$8 each for 2" and smaller
	\$13.00 \$15 plus \$13 each over 2"
Mobile Home Park Sewer	\$13.00 \$15 plus \$10 \$9.00 per space.

GAS PIPING

Up to five outlets	\$30
Over five outlets	\$30 plus \$4.50 \$5 for each outlet over five

**COMMUNITY DEVELOPMENT – BOARD OF ADJUSTMENT, REZONING,
SPECIAL USE PERMIT & SUBDIVISION**

Application:

Board of Adjustment	\$150
Rezoning/Special Use Permit/ Planned Unit Development (PUD)	\$500
Preliminary Plat	\$300 plus \$20 per lot review fee
Final Plat	\$300 plus \$15 per lot review fee
Administrative or Minor Plat	\$300

Other:

Administrative Fee	\$15
Complete Building Report	\$24 \$25 annually
Comprehensive Plan	\$35 plus tax
Land Development Ordinance	\$25 \$30 plus tax
Map Update Fee	\$25
Publications	Actual cost of publication
Signs (rezoning and special use & house moving)	\$17 plus tax
Zoning Verification Reports	\$25 \$30

COMMUNITY DEVELOPMENT – WIRELESS TELECOMMUNICATIONS FACILITIES

Application:

D.A.S. Node	\$200 per node
Eligible Facility Permit Colocation/Modification	\$1,000
Special Use Permit New Facility	\$3,000

COMMUNITY DEVELOPMENT – PERMITS TO OCCUPY THE RIGHT-OF-WAY

Application:

Temporarily Occupy	\$10 per day
Permanently Occupy	\$250 per Facility
Right-of-Way Use Rate (Not applicable to Right-of-Way Users which have a current Franchise agreement)	\$250 annually per facility, single linear run of underground utility infrastructure

COMMUNITY DEVELOPMENT – SMALL WIRELESS FACILITIES IN THE RIGHT-OF-WAY

Application:

Modify, Replace, and Install New Ground Mounted Facility or Pole	\$250 per Facility and Pole
<u>Co-location on Authority Pole:</u> Application Fee	\$500 minimum for up to 5 facilities, \$100 for each additional facility on the same application (maximum of 10)
Annual Usage Rate	\$20 per pole
Right-of-Way Use Rate	\$250 annually per small wireless facility

COMMUNITY DEVELOPMENT – CODE ENFORCEMENT

Nuisances:

Abatement of Nuisance/Rubbish	\$100 per hour (minimum of \$100) (including postage, dumping fees, legal fees, and \$50 administrative fee)
Weed Abatement	\$85 per hour (including postage, dumping fees, legal fees, and \$50 administrative fee)
Removal of Snow & Ice	\$85 per hour (including postage, legal fees, and \$50 administrative fee)
Towing	Postage, legal fees, and \$50 administrative fee *Towing fees will be invoiced by towing company.
Equipment	\$15 per hour

ECONOMIC DEVELOPMENT

PACE (Property Assessed Clean Energy) Program:

Application fee	\$1,000 due with application
Administrative fee	\$40,000 or 1% of the capital amount of the PACE project, whichever is less, due at closing
Annual fee	\$500 due annually for life of the bond

ENGINEERING

Application:

Vacation of street, alley, or easement	\$200
Administrative Fee	\$15
Map Update Fee	\$25
Plans and Specifications (Includes standard USPS mailing)	\$75 \$50 minimum - \$125 \$100 if purchased from Engineering Dept. \$30 \$15 if purchased from Quest CDN
RFQ, RFP, Design-Build Letter of Interest	\$15 \$10 from www.questCDN.com
Publications	Actual cost of publication.

Other:

36" x 48" Print (Map)	\$10 \$8 per sheet plus tax
24" x 36" Print (Map)	\$8 \$6 per sheet plus tax
Scanned Sheet plus actual time	\$60 per hour (minimum 1/2 hour):
24" x 36" and smaller	\$5 \$4 per sheet plus tax
CD and mailing charge	\$25 \$20
Sheets larger than 24" x 36" (incl. CD & mailing charge)	\$25 \$20 per sheet plus tax
Special Delivery (UPS, Federal Express, etc.)	Actual cost

FIRE

Rescue Service Fees

Definitions:

Tiered Response – Mutual aid to another department or district which does not have the type, volume, or level of service available to meet the needs of the incident or the patient(s). Mutual aid may be initiated by radio call or by standing agreement for automatic mutual aid/dual response per written agreement. In this situation, Columbus Fire Department (CFD) provides care, transportation, and medical supplies.

ALS Intercept – Aid to another licensed ambulance service in the State of Nebraska who has transport capability but needs ALS, and only has BLS care available. In this situation, our ALS personnel board their ambulance with necessary equipment and supplies and the transport continues. For billing purposes this is treated the same as an ALS treat & release. The ALS Intercept billing rate also applies to situations where CFD personnel arrive and treat but a third service, such as a helicopter, transports the patient.

- (a) \$725 Emergency Basic Life Support transport service call.
- (b) \$125 Basic Life Support treat and release (non-transport)
- (c) \$150 Lift Assist/Fall for private residences (non-transport).
- (d) \$350 Lift Assist/Fall for Assisted Living/Nursing Home Facilities/Midwest Medical Transport (non-transport).
- (e) \$1,056 Emergency Advanced Life Support Level One transport service call.
- (f) \$1,531 Emergency Advanced Life Support Level Two transport service call.
Same applies for Tiered Response (patient is transported in city ambulance)
- (g) \$493 Advanced Life Support treat and release or assist service call (non-transport).
- (h) \$493 Paramedic Intercept service call.
(other service transports patient with city medic on board)
- (i) \$19 per loaded patient mile.
- (j) Additional family members when treated at the same site and transported shall be charged the same fees as Basic Life Support or Advanced Life Support Level One or Two, whichever is appropriate.

(k) \$0 Dry run (no patient found or care not required).

These are global fees which cover cost of supplies, labor and medicines.

Reports: NARSIS	\$20 (incl. tax)
Fire	\$20 (incl. tax)

Other: SCBA Bottle	\$7 (incl. tax)
---------------------------	-----------------

Ambulance/Fire Apparatus Standby Personnel Fees

(a) Standby for service	\$75/unit/person/hour
(b) Ambulance	\$100/hour
(c) Fire Engine w/Jaws	\$100/hour
(d) Brush truck	\$50/hour
(e) Ladder truck	\$1,000/hour
(f) Install flag pole ropes or cables	\$500 each

HazMat Response

Services:

(a)	HazMat Technician (certified)	\$34.50/person/hour
(b)	HazMat Support (Operations level or higher)	\$20/person/hour
(c)	HazMat 2 (Kenworth) & HazMat Trailer (48 ft)	\$160/hour
(d)	HazMat 2 (Kenworth) with no trailer	\$80/hour
(e)	HazMat 1 (F350) & Decon Trailer	\$122/hour
(f)	HazMat 1 (F350) with no trailer	\$61/hour
(g)	Suburban & support trailer (incl. 6x6)	\$100/hour
(h)	Suburban with no trailer	\$50/hour
(i)	Fire Engine (in support of hazmat response)	\$200/hour

Stipend:

(a)	HazMat Technician (certified)	\$26.50/hour
(b)	HazMat Support (Operations level or higher)	\$15.45/hour

Fireworks Application Fees

All fees are non-refundable.

Applications received by 5 p.m. on June 10th

Minimum Sq. Ft.	Maximum Sq. Ft.	Fee (Per Location)
0	424	\$550
425	600	\$600
601	800	\$700
801	1600	\$900
1601	2400	\$1,250

Applications received June 11th through June 18th – Double the application fee.

Applications received June 19th through June 25th – Triple the application fee.

Applications received by 5 p.m. on December 19th

Minimum Sq. Ft.	Maximum Sq. Ft.	Fee (Per Location)
0	424	\$550
425	600	\$600
601	800	\$700
801	1600	\$900
1601	2400	\$1,250

Insurance Requirements:

Certificate of Insurance in the amount of \$1,000,000 per occurrence/\$2,000,000 aggregate coverage.

GENERAL ADMINISTRATION

Application for Franchise	\$500
Code Book	\$100
Code Book Updates	\$35 per year
Copies and Scanned Documents:	
Black & White (Letter & Legal)	\$.25 per copied page (incl. tax)
Colored (Letter & Legal)	\$.60 per copied page (incl. tax)
Black & White (11" x 17")	\$.50 per copied page (incl. tax)
Colored (11" x 17")	\$.75 per copied page (incl. tax)
Credit Card Convenience Fee:	
Charges under \$300	\$2
\$300 - \$700	\$10
\$701 - \$1,000	\$15
\$1,001 and above	Prorated
Documents prepared by City Attorney (i.e., waivers, easements, etc.)	Actual cost
Insufficient Funds	\$25 per occurrence
Recording/Administrative Fee	\$15
Reproduction of Recordings	\$20
Research	\$30 per hour (following 4 cumulative hours)
Liquor Licenses:	
Entertainment District	\$300
Publication Fee	\$15
Special Designated Liquor License	\$40 per day
Miscellaneous Licenses/Permits:	
Junk Shop	\$25 annually
Pawnbroker	\$50 annually plus \$5,000 bond
Itinerant Carnival, Show Troupe	
Itinerant or Commercial Entertainment	\$25 per day or \$100 per week
Tobacco – Retail (Fee set by State Statute)	\$15 annually plus Administrative Fee
Tobacco – Wholesale (Fee set by State Statute)	\$100 annually plus Administrative Fee
Occupation of Street (temporary storage on City property)	Certificate of Insurance \$1,000,000 per occurrence \$1,000,000 aggregate

GOLF COURSE

QUAIL RUN

Daily Green Fees

Rate

Weekday 9-hole	\$17.76
Weekday 18-hole	\$27.10
Weekend/Holiday 9-hole	\$23.83
Weekend/Holiday 18-hole	\$34.81
Junior/Senior/Super Senior Weekday 9-hole	\$14.02
Junior/Senior/Super Senior Weekday 18-hole	\$20.56
Twilight (two hours before sunset any day)	\$13.08
Winter Rates: December 1 – March 31	
9-holes	\$14.02
9-holes w/cart	\$18.69
18-holes	\$20.56
18-holes w/cart	\$27.10

Season Pass

Junior 7-day	\$220.26
Young Adult 7-day	\$514.02
Single 7-day	\$929.91
Family 7-day	\$1,308.41
Senior 7-day	\$836.45
Super Senior 7-day	\$742.99
Additional Spouse Pass for Above Categories	\$350.47

Individual Installment Pass

\$274 down payment due no later than February 15th and four payments of \$185 due February 28th, March 31st, April 30th and May 31st

Family Installment Pass

\$351 down payment due no later than February 15th and four payments of \$263 due February 28th, March 31st, April 30th and May 31st

Punch Cards (Individual or Corporate)

20 Punch 9-hole	\$350.47
20 Punch Senior/Super Senior 9-hole	\$280.37
20 Punch 18-hole	\$542.06
20 Punch Senior/Super Senior 18-hole	\$411.20

High School Teams – with range balls (Monday – Friday)

\$1,916.00

Cart Fees	Rate
9-hole	\$10.75
18-hole	\$16.12
Senior/Super Senior 9-hole	\$9.81
Senior/Super Senior 18-hole	\$14.95

Annual 1/2 Cart Pass

Individual	\$654.21
Spouse of Individual	\$327.11
Individual Senior/Super Senior	\$523.36
Spouse of Individual Senior/Super Senior	\$261.68

Age is determined by age at time of purchase.

Junior – 18 and Under

Young Adult – 19-23

Regular Adult – 24-59

Senior – 60-69

Super Senior – 70 and Over

Passes not valid for corporate/company/state, booster outings, or tournaments.

Fees are set by golf professional and are subject to change.

Reel Sharpening

One cutting unit (reel and bedknife) grinding only	\$50
Additional labor per hour plus parts	\$50
Minimum charge one hour	\$50

VAN BERG – Golf

Daily Green Fees

Rate

Weekday	\$13.08
Weekend/Holiday	\$15.89
Junior/Senior/Super Senior Weekday	\$11.21
Twilight (two hours before sunset any day)	\$10.28
Additional 9 holes – All players	\$6.54
Junior golfers (15 and under) play free at Van Berg when accompanied by a greens fee paying adult	

Cart Fees

9-hole	\$10.75
18-hole	\$16.12
Senior/Super Senior 9-hole	\$9.81
Senior/Super Senior 18-hole	\$14.95

Season Pass

Junior 7-day	\$220.26
Young Adult 7-day	\$514.02
Single 7-day	\$929.91
Family 7-day	\$1,308.41
Senior 7-day	\$836.45
Super Senior 7-day	\$742.99
Additional Spouse Pass for Above Categories	\$350.47

Individual Installment

\$274 down payment due no later than February 15th and four payments of \$185 due February 28th, March 31st, April 30th and May 31st

Family Installment

\$351 down payment due no later than February 15th and four payments of \$263 due February 28th, March 31st, April 30th and May 31st

Punch Cards (Individual or Corporate)

20 Punch Regular	\$261.60
20 Punch Senior/Super Senior	\$224.29

Lockbox (if used) - \$10 for all day – tax included

Age is determined by age at time of purchase.

Junior – 18 and Under

Young Adult – 19-23

Regular Adult – 24-59

Senior – 60-69

Super Senior – 70 and Over

Passes not valid for corporate/company/state, booster outings, or tournaments.

Fees are set by golf professional and are subject to change.

VAN BERG – FootGolf

Daily Green Fees

Rate (Incl. Tax)

Regular rate:

9 holes

\$10

18 holes

\$15

Junior rate (15 and under):

9 holes

\$7

18 holes

\$12

Ball rental

\$3

LIBRARY

Established by Library Board

Fines & Replacement Costs:

\$0.10 per day for each overdue book, audiobook, magazine, newspaper, or video recording (\$5 maximum).

\$0.50 per day for each overdue special collection item, including but not limited to, electronic device, game, puzzle, or equipment.

\$25 for any electronic device returned in book drop.

\$50 for overdue "By Reservation Only" projector.

Fee for Damaged/Lost/Unreturned Materials: Up to retail replacement cost of items. Patrons must pay the assessed cost of items. The library will not accept replacement items from patrons in lieu of payment for damaged, lost, or unreturned materials.

Service Fees:

\$1 for replacement of previously issued library or digital library card.

\$40 annually (\$25 for six months) for library privileges for residents outside of Columbus who are not eligible for a free card (per the library card policy).

\$5 for each test proctored (faxing fees and postage may apply).

\$1 per page for outgoing faxes (\$5 maximum up to 25 pages, \$1 per each additional page).

\$0.10 per black & white print made on standard printer/copier.

\$0.25 per color print made on standard printer/copier.

Makerspace fees:

Consumable materials used in the Makerspace are charged to users at cost plus sales tax. Prices are posted in the Makerspace.

Interlibrary Loan (ILL):

Unusual or international postage fees charged by the lending library will be charged after consultation with patron.

\$3 postage recovery fee will be charged to any patron who fails to pick up a requested interlibrary loan book before it expires.

PARKS AND RECREATION

Established by Board of Parks Commissioners

All fees are non-refundable.

Athletic Fields:

Recreation Leagues-Baseball/Softball	\$15/Field/Day Youth \$35/Field/Day Adult
Organized Leagues-Baseball/Softball	\$55/Field/Day Youth/Adult
Tournaments-Baseball/Softball	\$55/Field/Day Youth/Adult
Recreation Practice-Baseball/Softball	No Charge Youth/Adult BUT must be scheduled through CPR or not permitted (CPR=Col Parks and Rec)
Camps/Clinics-Baseball/Softball	\$35/Field (2 hour increments) Youth/Adult
Bark Park: Reservation	\$35

Baseball:

High School	\$70 for refuse disposal Electricity is 35% of actual usage during high school season.
American Legion	Electricity is 35% of actual usage for each season.

Due to proximity of the track and ball field, no baseball games shall be scheduled at the same time a track meet is in progress. Baseball practice may take place, but limited to a practice where balls do not land in the track and football field area.

ALL OTHER GAMES MUST BE APPROVED BY THE PARK BOARD/CHARGE WILL BE \$155.

Bleachers:

Bleacher rental for special events held in a city park will be \$93 per bleacher (5 row only), per event. The city will deliver and pick up – contingent upon availability.

Clinics:

Non-Profit (if sponsor is a local organization, i.e., Legion, AYSO, Youth Softball, etc.)	\$60 (includes refuse disposal)
Private (defined as “Profits to be used for Individual’s benefit.”)	\$215/Day \$240/Day, if lights are used

Park Board Approval Required

Horseshoe Courts:

Electricity	\$100/Season
Tournaments	\$65/Tournament

Shelter Reservations:

Glur Park Shelter	\$50/Day
Pawnee Park West Shelter	\$25/Table
Pawnee Park East Shelter	\$50/Day

Payable at time reservation is made. No refunds.

Soccer:

Electricity is 35% of actual usage for each season.

Softball:

High School/College Softball	\$70 for refuse disposal
------------------------------	--------------------------

Electricity is 35% of actual usage for each season.

Stadium Reservations:

\$150 plus cleanup per event where no admission is charged or concession used. Park crew wages will be added to the \$150 fee for cleanup.

\$225/event where admission is charged.

\$300/event where concession is used.

\$650/event where admission and concession is used.

\$25 50/hour for video board usage

Stadium – Marching Band Festival: \$800

Events may be cancelled, postponed, or moved to another sight upon discretion of the Park Superintendent or ~~Public Property Director~~Parks and Recreation Director due to weather or extraordinary circumstances.

Tennis:

High School \$500/School year

Six Courts

All Reservations & Tournaments \$35 for 6 courts, 2 hours per day
having Park Board approval \$100 for 6 courts per day

Per Court

Park Board Approval \$26/Court/Day

Tennis Association Electricity Fee \$275/Season

Tournaments: (Softball, Baseball, and Soccer)

Weekend or Holiday Tournaments Requiring Extra Cleanup
(Garbage Receptacles Emptied Only) \$70/Day

Track:

Practice per season, per school \$335
(Columbus and Scotus High Schools,
Columbus Middle School & Scotus Jr. High)

Invites and Relays \$195/Meet

Districts or Conference \$270/Meet
\$395/Meet (not involving Columbus schools)

Dual/Triangular Meets \$70/Meet

Electronic Timing System \$210/Meet

Special Olympics \$50

No track practice can be held when a scheduled track meet is in progress. Due to proximity of the track and ball field, no baseball games shall be scheduled at the same time a track meet is in progress. Baseball practice may take place, but limited to a practice where balls do not land anywhere in the track and football field area.

Cost for items such as hurdles, jumping standards, jumping pits, and pole vault boxes will be split between the City, Columbus High School, and Scotus High School.

Wedding Reservation \$36

Condition of area for wedding is "as is".

PARKS AND RECREATIONAL PROGRAMS:

High School Coed Sand Volleyball League	\$75/Team
High School Girls 4 on 4 Sand Volleyball League	\$50/Team
Junior High Girls 6 on 6 Sand Volleyball League	\$75/Team
Pickleball League	\$40/Team
Men's Pickleball Tournament	\$15/Individual
Fitness Bootcamp in Pawnee Park	\$90/Participant (9 classes) \$10/Day
(Participants must register for full bootcamp session)	
Family Fitness in Pawnee Park	\$10/Family/Day
Fundamental Tennis Clinic	\$60/Participant (4 days)
Fall High School Coed Slow Pitch Softball Rec League	\$120/Team
Adult Coed Kickball	\$200/Team
Adult Coed Flag Football	\$200/Team
Adult Softball League	\$575/Team
Extracurricular Programs	Fees established as programs are scheduled.

Program fees are non-refundable.

POLICE

Impounded Vehicle:

Outside Storage	\$10 per day
Inside Storage	\$20 per day
Towing	Per agreement w/towing companies
Administrative Fee	\$30

Miscellaneous:

Reports (pick up in person)	\$5 First Page - \$1 Add'l Page
Faxes	\$5 First Page - \$1 Add'l Page
Criminal History Fee	\$10
Photograph	\$1 per photo
Audio/Video Reproduction	\$20
CD containing audio/video/photo reproduction	\$20
Fingerprints	\$5 per card
Bike License	\$5
ATV/UTV/Golf Car Permit	
Fiscal Year 2022-2023	\$20
Fiscal Year 2023-2024	\$30
Fiscal Year 2024-2025	\$40
Fiscal Year 2025-2026	\$50
Gun Permit	\$5
Vendor/Solicitor Permit	\$15 per day or \$30 per month
Parking	\$15 - \$500

False Alarm:

One – Four	No Charge
Five – Seven	\$25 each
Eight – Ten	\$50 each
Eleven – Subsequent	\$100 each

Fire False Alarm:

First False Alarm	No Charge
Any subsequent within 6 months	\$100

Registration:

Vacant Building	\$5
-----------------	-----

Parking Violations:

The fines for parking violations, if paid within five (5) days are as follows:

Handicapped (Disabled) Parking, 1 st Offense:	\$150
Handicapped (Disabled) Parking, 2 nd Offense:	\$300 within one-year period
Handicapped (Disabled) Parking, 3 rd Offense:	\$500 within one-year period
Restricted Parking Lot, 1 st Offense:	\$15
Restricted Parking Lot, 2 nd Offense:	\$25
Restricted Parking Lot, 3 rd Offense:	\$100
Parking Near Fire Hydrant	\$25
Parking in Fire Lane	\$25
Parking Near Street Intersection	\$15
Parking Within Sidewalk Space	\$15
Parking Near Traffic Control Device	\$15
Semi-Truck/Trailer and Commercial Vehicle Violation	\$15
Angle Parking	\$15
Parking of Oversize Vehicles, Trailer, Mobile Home, Camping Trailer, or Bus in Residential Districts	\$15
School Buses Stopped	\$15
Parking Prohibited on Certain Streets	\$15
Parking Upon Roadways or City Parking Lots for certain purposes prohibited	\$15
Abandoned Vehicle	\$15
Obstructing Driveways or Roads	\$15
Painting Curbs, Prohibited	\$15
Parking In Alleys	\$15
Impeding or Obstructing Traffic	\$15
Standing in Loading Zone	\$15
Large Vehicles Parked	\$15
Parking for the purpose of selling merchandise	\$15
Parallel Parking	\$15
Streets Without Curb	\$15
Parking Time Limits	\$15
Stopping, Standing, or Parking in places which would cause hazardous conditions or traffic congestion	\$15
Parking with left side to curb prohibited	\$15
Unattended Motor Vehicles	\$15

The fines for all parking violations will double if not paid within five (5) days from the date the citation was issued.

The storage fee for vehicle impound lot will begin the day vehicle is placed into impound and end the day vehicle is removed from impound.

POLICE - ANIMAL CONTROL

Licensing:

Exotic Animal	\$20 + Administrative & Publication
Dog and Cat (January-December Intact)	\$25
Dog and Cat (January-December Altered)	\$13
Replacement Tag	\$3

Lifetime Dog and Cat License: *Non-transferable and Non-refundable*

6 months to 5 years old	\$100
over 5 years old	\$50

Impound Fees:

First Offense	\$15
Second Offense	\$25
Third Offense and each thereafter	\$40

Daily Charge for Animal in Custody	\$10
------------------------------------	------

Unclaimed livestock found stray that are not able to be housed at the shelter will be charged same rates assessed by outside agency (i.e., sale barn, vet clinic or other organization contracted for this service.)

Animal under investigation at shelter for either a bite, vicious, or dangerous investigation case

\$25 per day

Upon the owner of any animal claiming their pet, the owner shall be responsible for all medical costs incurred by the City of Columbus while in the custody of the City of Columbus.

City Live Animal Trap Program:

Refundable Deposit	\$50
--------------------	------

Commercial Animal Establishment: \$100 annually

Hobby Beekeeper Application (non-refundable) \$20

Dangerous Dog Appeal (non-refundable) \$100

PUBLIC WORKS - STREET

Equipment Charges (for equipment only):

Equipment	Per Hour Cost + labor	Minimum
Backhoe	\$100	\$200
Boom Truck/Sign Truck	\$100	\$200
Chipper	\$50	\$100
Compressor	\$50	\$100
Concrete Saw	\$8 per foot	\$100
Dump Truck	\$50 five yards	\$100
Dump Truck	\$100 ten yards	\$200
Grader	\$150	\$300
Loader	\$100	\$200
Pickup	\$30	\$60
Sweeper	\$75	\$150
Tractor	\$50	\$100
VAC Trailer	\$125	\$175
Mower	\$125	\$150

Other equipment charges will be actual costs plus a 10% administrative charge (with a 2 hour minimum charge).

Labor charge (per employee) is \$55 per hour up to the first 8 hours and \$80 for each hour thereafter for an 8 hour work day (minimum charge of \$70).

Sidewalk Replacement ~~\$250~~ \$300 for 25 sq. ft.(min.) ~~\$8~~ \$10/sq. ft. for each add'l sq. ft.

Street Replacement ~~\$350~~ \$400 for 25 sq. ft (min.) ~~\$14~~ \$13/sq. ft. for each add'l sq. ft.
Only concrete (6" typical)

Street Replacement w/

Asphalt Overlay ~~\$300~~ \$350 for 25 sq. ft. (min.) ~~\$10~~ \$12/sq.ft. for each add'l sq. ft.

Street Replacement w/

Only Asphalt (6" typical) ~~\$250~~ \$300 for 12 sq. ft. (min.) ~~\$9~~ \$11/sq. ft. for each add'l sq. ft.

Removal of Right of Way Tree:	With Tree Replacement	\$15
	Without Tree Replacement	\$75

Tree Service \$15 annually & Liability Insurance of \$500,000/\$1,000,000

Pruning of Branches on Right of Way or Park Trees for Purpose of Moving a Building must be done by contractor.

Utility Cuts ~~\$8~~ \$15 per lineal foot ~~\$100~~ \$200 minimum

Excavation Permit:

	FEE (per sq. ft.)	DEPOSIT (per sq. ft.)
Concrete less than 4" depth	\$5 \$10	\$4.80
Concrete 4" – 6" depth	\$5 \$10	\$5.00
Concrete over 6" depth	\$5 \$10	\$5.50
Asphalt less than 4" depth	\$5 \$10	\$2.65
Asphalt 4" – 6" depth	\$5 \$10	\$3.35
Asphalt over 6" depth	\$5 \$10	\$3.50
Gravel	\$4 \$10	\$6.00
Fill Material	\$4 \$10	\$25.00 per cu. yd.

~~(Deposit or bond will be returned after excavation has been repaired by applicant, inspected by City Street Department, and determined to have been restored to City's satisfaction. Should area not be restored by applicant, City will restore and deposit or bond will not be refunded. charge the If cost of restoration by city. exceeds amount of deposit or bond, applicant will be responsible for payment of difference. A bond must be a separate bond specifically for excavation project.)~~

PUBLIC WORKS - TRANSFER STATION

Garbage Hauler Licensing Fees & Requirements: \$150 annual fee + bond in an amount equal to 1/4 of the total transfer station charges incurred by the licensed hauler during the preceding calendar year. Those haulers not in business for one full year will post a bond of \$5,000.

Overweight Permit: \$100 per vehicle

City Fees: The following quantities and fees shall apply to the weight of all municipal solid waste, refuse, and materials deposited or unloaded at the Solid Waste Transfer Station:

Category	Fee	Minimum
Solid Waste Availability Fee (billed on water/sewer utility bills and collected as such):		
Residential	\$2 per month	
Commercial	\$6 per month	
Industrial	\$10 per month	
 Municipal Solid Waste Tipping Fee deposited or unloaded other than by a licensed garbage hauler:	 \$69 per ton	 \$15 per vehicle (up to 320 lbs)
(An additional trailer shall be considered an additional vehicle.)		
 Community Cleanup Rate:	 \$10 minimum	 (up to 2 days, twice a year)
 Municipal Solid Waste Tipping Fee deposited or unloaded by a licensed garbage hauler:	 \$42 per ton	
+ Occupation Tax	\$27 per ton	
<i>* Occupation Tax is covered in Columbus City Code – Section 111.03</i>		
 Wood pallets, construction and demolition debris or masonry rubble deposited or unloaded other than by a licensed garbage hauler:	 \$69 per ton	 \$3.50 per vehicle (up to 100 lbs)
(An additional trailer shall be considered an additional vehicle.)		
 Wood pallets, construction and demolition debris or masonry rubble deposited or unloaded by a licensed garbage hauler:	 \$42 per ton	
+ Occupation Tax	\$27 per ton	
<i>* Occupation Tax is covered in Columbus City Code – Section 111.03</i>		

Category	Fee	Minimum
Trees and limbs (virgin wood) deposited or unloaded at the Solid Waste Transfer Station or other designated dumping grounds (other than by a licensed garbage hauler): (An additional trailer shall be considered an additional vehicle.)	\$69 per ton	\$2.50 per vehicle (up to 80 lbs)

Trees and limbs (virgin wood) deposited or unloaded at the Solid Waste Transfer Station or other designated dumping grounds (by a licensed garbage hauler):	\$42 per ton
+ Occupation Tax.	\$27 per ton

** Occupation Tax is covered in Columbus City Code – Section 111.03*

Trees and limbs (virgin wood) deposited or unloaded at the Solid Waste Transfer Station or other designated dumping grounds weighing less than 20 lbs:	No Charge
--	-----------

Any material deposited or unloaded which causes any damages or plugging up of the Transfer Station push pits:	Actual cost of incurred expense	\$75 per occurrence
---	---------------------------------	---------------------

Equipment:	Per hour cost	Minimum
Dump Truck	\$50	\$100
Loader	\$100	\$200
Pickup	\$30	\$60

Other equipment charges will be actual costs plus a 10% administrative charge (with a 2 hour minimum charge)

Labor charge (per employee) is \$55 per hour up to the first 8 hours and \$80 for each hour thereafter for an 8 hour work day (minimum charge of \$70).

Inoperative Scales: If the scale is inoperative for any reason, the charge to licensed collectors and others with charge accounts shall be the average charge per load for the previous full month or the operator may require customers to acquire a weight slip from a commercial scale.

Right of Refusal: Should any illegal or questionable material be brought to the transfer station to be deposited or unloaded, the transfer station reserves the right of refusal of the material.

PUBLIC WORKS - WATER/SEWER UTILITIES

Water Rate Table:

Rates per 1,000 gallons or portions thereof:

Use	Location	10/01/17	10/01/18	10/01/19	10/01/20	10/01/21
Residential	Inside City Limits	\$1.35	\$1.35	\$1.35	\$1.35	\$1.35
Residential	Outside City Limits	\$2.68	\$2.68	\$2.68	\$2.68	\$2.68
Commercial	Inside City Limits	\$1.21	\$1.21	\$1.21	\$1.21	\$1.21
Commercial	Outside City Limits	\$2.63	\$2.63	\$2.63	\$2.63	\$2.63
Industrial	Inside City Limits	\$1.19	\$1.19	\$1.19	\$1.19	\$1.19
Industrial	Outside City Limits	\$2.47	\$2.47	\$2.47	\$2.47	\$2.47

Monthly Service Charges:

Meter Size					
3/4"		\$6.78	\$6.78	\$6.78	\$6.78
1"		\$6.78	\$6.78	\$6.78	\$6.78
1-1/2"		\$20.35	\$20.35	\$20.35	\$20.35
2"		\$33.92	\$33.92	\$33.92	\$33.92
3"		\$67.85	\$67.85	\$67.85	\$67.85
4"		\$101.77	\$101.77	\$101.77	\$101.77
6"		\$203.54	\$203.54	\$203.54	\$203.54
8"		\$339.24	\$339.24	\$339.24	\$339.24
10"		\$508.86	\$508.86	\$508.86	\$508.86
12"		\$949.86	\$949.86	\$949.86	\$949.86

Special Water: For water connections that have never been assessed or charged for water service.

Special Connection Charge for Lots 66' or less
 - Outside City Limits \$2,508.00
 \$110.00 additional

Special Connection Charge for Lots in excess of 66'
 - Outside City Limits \$38.00 per front footage
 \$110.00 additional

Sewer Rate Table:

Rates per 1,000 gallons or portions thereof:

Use	Location	10/01/17	10/01/18	10/01/19	10/01/20	10/01/21
Residential	Inside City Limits	\$4.22	\$4.43	\$4.65	\$4.88	\$5.13
Residential	Outside City Limits	\$6.06	\$6.36	\$6.68	\$7.02	\$7.37
Commercial	Inside City Limits	\$4.22	\$4.43	\$4.65	\$4.88	\$5.13
Commercial	Outside City Limits	\$6.06	\$6.36	\$6.68	\$7.02	\$7.37
Industrial	Inside City Limits	\$4.22	\$4.43	\$4.65	\$4.88	\$5.13
Industrial	Outside City Limits	\$6.06	\$6.36	\$6.68	\$7.02	\$7.37

Monthly Service Charges:

Meter Size					
¾"	\$7.74	\$8.13	\$8.53	\$8.96	\$9.41
1"	\$7.74	\$8.13	\$8.53	\$8.96	\$9.41
1-½"	\$23.22	\$24.38	\$25.60	\$26.88	\$28.23
2"	\$38.71	\$40.64	\$42.67	\$44.81	\$47.05
3"	\$77.41	\$81.28	\$85.35	\$89.61	\$94.09
4"	\$116.12	\$121.92	\$128.02	\$134.42	\$141.14
6"	\$232.24	\$243.85	\$256.04	\$268.84	\$282.28
8"	\$387.06	\$406.41	\$426.73	\$448.07	\$470.47
10"	\$580.59	\$609.62	\$640.10	\$672.11	\$705.71
12"	\$1,083.77	\$1,137.96	\$1,194.85	\$1,254.60	\$1,317.33

Special Sewer: For sewer connections that have never been assessed or charged for sanitary sewer service.

Special Connection Charge for Lots 66' or less \$1,650.00
 - Outside City Limits \$110.00 additional

Special Connection Charge for Lots in excess of 66' \$25.00 per front footage
 - Outside City Limits \$110.00 additional

Sewer Surcharge Rate: BOD \$0.234 per pound
 TSS \$0.194 per pound
 Grease \$0.388 per pound

Disposal of Septic Waste or Portable Waste at the WWTF \$0.05 per gallon

Stormwater Management Program:

Residential zoning (AG, RR, R-1, R-2, R-3, and RMH)

Tier No.	Parcel Max Impervious Surface Area (sq. ft.)	Rate
1	between 0.0 and 4,000	\$3.00
2	between 4,001 and 6,000	\$3.25
3	between 6,001 and 50,000	\$3.50
4	greater than 50,000	\$6.00

Commercial zoning (O, LC, UC, B-1, and B-2) and Industrial zoning (ML/C-1 and MH)

1	between 0 and 36,000	\$3.00
2	between 36,001 and 195,000	\$4.75
3	between 195,001 and 1,450,000	\$9.00
4	greater than 1,450,000	\$11.50

Grease Management Program:

Grease Trap interceptor and/or automatic grease removal device	
Annual permit	\$50 per unit
Annual inspection	\$35 per site
Late fee and/or non-permitted activity	\$100 per unit/per occurrence
Grease disposal	\$0.15 per gallon

Nonresidential Strength Wastewater shall be charged actual costs based on composition of the waste for treatment, handling, and disposal plus a 10% administrative charge.

Water/Sewer Miscellaneous:

Water Permit	\$50 each	
Sewer Permit	\$50 each	
Water – Turned On	\$25 per occurrence	Non-Payment & Convenience Call
	\$50	Non-Payment – After 5 pm of the day of request
	\$100	Convenience call - After 5 pm of the day of the request
Water – Shut Off	\$25 per occurrence	Non-Payment & Convenience Call
	\$100	Convenience call - After 5 pm of the day of the request
Insufficient Funds	\$25 per occurrence	
Filling Consumer Tanks	\$5 for first 1,000 gallons & \$3.75 for each add'l 1,000 gallons or portions thereof over 1,000 gallons.	
Rates for Building Under Construction	Regular charge-as though water was taken by regular customer service.	

Equipment:	Per Hour Cost	Minimum
Backhoe	\$100	\$200
Compressor	\$50	\$100
Dump Truck	\$50 five yards	\$100
Dump Truck	\$100 ten yards	\$200
Loader	\$100	\$200
Service Truck	\$45	\$90
Service Van	\$50	\$100
Pumps	\$50	\$100
Tapping Machine	\$150 per tap	
Fire Hydrant:		
Meter	\$100 deposit	
Flush Valve	\$100 deposit	\$30 monthly
Water Line Freeze Pack	\$100 per line	

Other equipment charges will be actual costs plus a 10% administrative charge (with a 2-hour minimum charge).

Labor charge (per employee) is \$55 per hour up to the first 8 hours and \$80 for each hour thereafter for an 8-hour work day (minimum charge of \$70).

Service:

Sewer Cleaning	Commercial	Residential
Wash Down	\$75 per hr. - \$150 minimum	\$50 per hr. - \$100 minimum
Haul Water	\$75 per hr. plus current water rates	\$75 per hr. plus current water rates

Video Inspection: Rates are charged as per foot for contract Video Inspections or Service Locates. This rate is for video inspection only. If lines need to be cleaned, contractor will be charged as per fee schedule. If any other labor is involved, the contractor will be charged for additional labor.

Line Size	Cost	Minimum
6" Sewer Lines	\$.75 per ft.	\$100
8" Sewer Lines	\$1.00 per ft.	\$125
10" Sewer Lines	\$1.50 per ft.	\$150
12" Sewer Lines	\$2.00 per ft.	\$200

Labor charge (per employee) is \$55 per hour up to the first 8 hours and \$80 for each hour thereafter for an 8-hour work day (minimum charge of \$70).

Combination Pressure/Vacuum Cleaning Sewer Line: Rates are charged as per foot for contract Vacuum/Cleaning Sewer Line Services. This rate is for pressure/vacuum cleaning only. If any other labor is involved, the contractor will be charged for additional labor.

Line Size	Cost	Minimum
6" Sewer Lines	\$.75 per ft.	\$100
8" Sewer Lines	\$1.00 per ft.	\$125
10" Sewer Lines	\$1.50 per ft.	\$150
12" Sewer Lines	\$2.00 per ft.	\$200

Labor charge (per employee) is \$55 per hour up to the first 8 hours and \$80 for each hour thereafter for an 8-hour work day (minimum charge of \$70).

10.A.1.c. Pay plan.

ORDINANCE NO. 23-_____

AN ORDINANCE OF THE MAYOR AND COUNCIL OF THE CITY OF COLUMBUS, NEBRASKA, REGARDING THE SALARIES OF OFFICERS AND EMPLOYEES; PAY PLAN FOR ALL CLASSIFICATIONS WITHIN THE CITY; AND HOURLY SALARY RANGES FOR EACH INDIVIDUAL CLASSIFICATION.

BE IT ORDAINED BY THE MAYOR AND COUNCIL OF THE CITY OF COLUMBUS, NEBRASKA, that the following pay plan for all classifications within the city be established:

2023-2024
PAY SCALE TABLE

GRADE A5 \$14.45 - \$19.08
Program Assistant

GRADE A7 \$15.51 - \$20.45
Lead Lifeguard /Program Coordinator
Library Assistant

GRADE B2 \$17.53 - \$23.68
Customer Service Account Clerk

GRADE B3 \$18.61 - \$25.15
Area Transit Driver
Library Assistant II
Library Maintenance Worker
Office Associate

GRADE B4 \$19.26 - \$26.00
Area Transit Supervisor
Building Maintenance
Transfer Station Scale Clerk

GRADE B5 \$19.94 - \$26.92
Customer Service Clerk
Library Assistant III
Office Associate II
Police Records Clerk

GRADE B6 \$20.63 - \$27.89
Account Clerk
Finance Account Clerk
Library Assistant IV
Pool/Water Park Maintenance Technician

GRADE B7 \$21.34 - \$28.81
Account Clerk II/ Records Clerk II
Code Enforcement Technician
Communications Specialist (911 Dispatcher)
Community Service Technician
Customer Service Clerk II
Equipment Operator
Parks Maintenance Worker
Parks Recreational Maintenance Worker
Police Records Clerk Lead

GRADE B8 \$22.11 - \$29.84
Administrative Assistant
Aquatics Supervisor
Customer Service Supervisor
Equipment Operator II
Finance Account Clerk II
Golf Course Crew Leader
Head Cook
Senior Office Associate

GRADE B9 \$22.93 - \$30.93
Account Clerk III
Assistant City Clerk
Equipment Operator III

GRADE B10 \$23.75 - \$32.08
Engineering Drafter/Aide
Mechanic
Parks Crew Leader
Public Property Maintenance Mechanic
Senior Office Associate II
Street Dispatcher
Transfer Station Operator
Wastewater Treatment Facility Operator

GRADE B11 \$24.65 - \$33.28
Accounting Specialist
Community Coordinator
Lead Communications Specialist
Water Production Operator
Water Utility Maintenance Worker

GRADE B12 \$25.56 - \$34.53
Airport Manager
Engineering Administrative Specialist
Mechanic II

GRADE B13 \$26.50 - \$35.80
Senior Center Manager
Computer Technician
Librarian
Park & Rec Coordinator
Park & Rec Coordinator (Aquatics)
Public Communications Manager
Transfer Station Supervisor
Wastewater Treatment Facility Operator II
Wastewater Treatment Facility Laboratory Technician
Water Production Operator II

GRADE B14 \$27.49 - \$37.12
Cemetery Supervisor
Street Crew Leader
Water Utility Maintenance Worker II

GRADE B15 \$28.50 - \$38.49
Water Production Crew Leader
Water Utility Crew Leader

GRADE B16 \$29.56 - \$39.91
Building Inspector

GRADE B17 \$30.65 - \$41.40
GIS Supervisor

GRADE B18 \$31.81 - \$42.94
Computer/Network Technician
Engineering Project Manager

GRADE C2 \$33.64 - \$47.09
City Clerk
Golf Course Superintendent
Parks Superintendent
Planning & Economic Development Coordinator
Street Superintendent
Surveyor/Construction Observer

GRADE C3 \$35.50 - \$49.69
Chief Building & Code Official
Library Director
Wastewater Treatment Facility Superintendent
Water Superintendent

GRADE C4 \$37.62 - \$52.68
Assistant Fire Chief
Park & Recreation Director
Project Engineer
Public Property Director

GRADE C5 \$40.07 - \$56.09
Police Captain

GRADE C6 \$42.87 - \$60.03
Communications Director
Community Development Director
Fire Chief

GRADE C7 \$46.08 - \$64.52
Human Resources Director
Police Chief

GRADE C8 \$50.00 - \$69.99
Public Works Director

GRADE C9 \$54.49 - \$76.30
City Engineer
Finance Director

OTHER POSITIONS

City Administrator per Resolution R20-140 \$233,604 annual
Prosecuting Attorney \$ 3,940.00 per month through 3/15/24
City Attorney \$ 185.00 per hour
City Emergency Mgmt Director \$10,000.00 per year
Mayor per Resolution R06-107 \$11,838.00 per year
Council per Resolution R06-107 \$ 7,381.00 per year

This ordinance shall repeal all ordinances or portions thereof in conflict herewith.
This ordinance shall be published as required by law and shall become effective October 1, 2023.

INTRODUCED BY COUNCIL MEMBER _____

PASSED AND ADOPTED THIS ____ DAY OF _____, 2023.

MAYOR

ATTEST:

CITY CLERK

APPROVED AS TO FORM:

CITY ATTORNEY

10.A.1.d. Capital improvement plan.

2024 Capital Improvement Plan

Notes		Dept. Requested 2024 Budget	2024 Budget Funding Source					2025 Budget	2026 Budget	2027 Budget	2028 Budget
			1% Sales Tax	1/2% Sales Tax	HWY & FFPP	OTHER	Total				
	<i>General</i>	City Hall Bond Payment	551,750	551,750			551,750				
100-100-57200-20003	1	FEMA Hazard Mitigation BRIC Grant	200,000	50,000		150,000	200,000				
100-100-57510-20005	3	Misc IT Expenses	70,000	70,000			70,000	70,000	70,000	70,000	70,000
100-100-57510-20006	4	Eagle View/Pictometry Upgrade	18,200	18,200			18,200	19,000	19,000	19,000	19,000
100-100-57200-21092	5	City Hall Relocation	150,000	150,000			150,000				
		Expand CCB east parking lot to north	200,000	100,001		99,999	200,000				
		Downtown Business Improvement District Mat	45,230	45,230			45,230				
		CCB Playground	250,000			250,000	250,000				
		Downtown Revitalization Match	400,000	50,000		350,000	400,000				
		FEMA Buyout Program	165,000			165,000	165,000				
100-100-57510-21089	7	Gas Pump Upgrades (1/3 of total)	10,000	10,000			10,000				
100-110-57510-21001	9	<i>CAT</i>									
		Radio Improvements	100,000	100,000			100,000				
100-110-57520-21005	10	<i>Police</i>									
		Police Fleet Vehicle	75,000	75,000			75,000	82,500	90,750	99,825	109,807
100-110-57520-21006	11	Police Fleet Vehicle	75,000	75,000			75,000	82,500	90,750	99,825	109,807
100-110-57520-21007	12	Police Fleet Vehicle	75,000	75,000			75,000	82,500	90,750	99,825	109,807
100-110-57520-21008	13	Police Admin Vehicle	20,000	20,000			20,000	21,000	22,000	23,000	24,000
	14	Tasers	100,000	100,000			100,000				
	18	Gas Pump Upgrades (1/3 of total)	10,000	10,000			10,000				
100-120-56190-20022	24	<i>Fire/Rescue</i>									
		Rosenbauer Ladder Truck Repairs	160,000	160,000			160,000				
		Turnout Gear	200,000	200,000			200,000	30,000	35,000	40,000	45,000
	22	New Medics Unit	500,000	425,000		75,000	500,000				
		Medicare Ground Ambulance Data Collection	35,000	35,000			35,000				
	25	SCBA Washer	50,000	50,000			50,000				
	27	Class A Uniforms	25,000	25,000			25,000				
	26	Pagers	25,000	25,000			25,000				
	23	Stryker/Physio Lease Agreement	200,000				-				
100-130-57200-20030	28	<i>Library</i>									
		New Library Building	500,000	500,000			500,000				

	<i>Parks</i>	Gerrard Park Pickleball Courts	400,000	400,000	400,000				
		Repair Vandalism to Playsets	10,000	10,000	10,000				
30		Replace Roof at Pawnee Park Large Shelters	40,000	40,000	40,000				
100-150-57200-21068	33	Armor Coat Gerrard, Centennial & Wilderness	80,000	80,000	80,000				
	34	16' Mower	80,000	80,000	80,000				
		Gas Pump Upgrades (1/3 of total)	10,000	10,000	10,000				
100-151-57510-20059	41	<i>Pawnee Plunge</i>	Camera Replacement	30,000	30,000				
	42	<i>Aquatic Center</i>	Filter Replacement	25,000	25,000				
	46	<i>VanBerg</i>	Storage Building Roof Replacement	30,000	30,000				
100-155-57200-23018	47		10 Golf Carts	60,000	60,000				
	45		Greens Mower	50,000	-			50,000	
	48	<i>Quail Run</i>	13' Rotary Mower for Rough	70,000	90,000			90,000	
	49		2nd Rough Mower	50,000	-			50,000	
		<i>Streets</i>	23rd Street Bond Payment (Payment 205k - T:	80,000	80,000				
200-200-57200-21077	50		School/PED Crossing	100,000	-			150,000	150,000
200-200-57300-20070	51		Subdivision or Misc Improvements	275,000	275,000			285,000	300,000
200-200-57300-20071	52		City Wide Pavement Rehabilitation	2,000,000	1,533,123	1,533,123		2,100,000	2,200,000
200-200-57300-20075	53		ADA Improvements & Services	55,000	55,000			55,000	60,000
200-200-57300-20077	54		HWY 30/23rd Street Reconstruction	2,400,000	2,400,000			350,000	60,000
			HWY 30/23rd St Construction Engineering	200,000	200,000				65,000
200-200-57200-22023	56		Levee Piping Inspection/Repairs	75,000	75,000				
	58		SID #188 Shady Lake Rd 54th to West Limits	2,800,000	-			2,800,000	
	59		SID #190 42nd St Roundabout West & Trail to	1,900,000	-			1,900,000	
	60		Used 35' Boom Truck	65,000	65,000				
	61		12' Snow Plow	15,000	15,000				
	62		2024 Service Pickup	50,000	50,000				
	65	<i>Airport</i>	Utility Vehicle	35,000	35,000				
205-205-57200-23030	66		8 Place T-Hangers	1,800,000	345,000	1,455,000		1,800,000	
205-205-57200-22024	67		Major ALP Update	300,000	30,000	270,000		300,000	
	68		Self-Serve Fuel Tank	150,000	150,000			150,000	
	69		Vehicle Lift	8,000	8,000			8,000	
220-220-57510-21084	70	<i>JCC</i>	Tower/Radio Equipment Contingency	37,500	37,500	37,500		37,500	
	71		State Radio System Equipment	800,000	800,000	800,000		800,000	
			Total Non-Discretionary		5,158,181				

		DISCRETIONARY							
100-100-57200-23001	6	1 City Workforce/Affordable Housing Subdivisor	1,000,000	1,000,000	1,000,000				
	35	2 Downtown Improvements	125,000	125,000	125,000	125,000	125,000	125,000	125,000
200-200-57200-22022	55	3 Centennial Park Restroom/Concession	400,000	400,000	400,000				
100-100-57510-19009	2	4 Downtown UPRR Grade Sep Study	400,000	400,000	400,000	150,000			
		5 WiFi in Public Spaces Phase 2	550,000	550,000	550,000				
		6 City Owned Billboard	250,000	250,000	250,000				
100-150-57200-23046	39	7 Master Trail (South Columbus 8th or 6th Stree	500,000	500,000	500,000	200,000	200,000	200,000	200,000
		8 Renovation of Parking Lot South of CCB	200,000	200,000	200,000				
100-150-57300-23012	38	9 Memorial Stadium Study	500,000	500,000	500,000				
100-150-57200-21067	32	10 Splash Pad-Centennial Park	350,000	70,000	280,000	350,000			
	43	11 Locker Room Renovations	20,000	20,000	20,000				
200-200-57200-23022	57	12 Lost Creek Parkway Traffic Control (18th, 33rc	300,000	300,000	300,000	300,000	300,000		
100-155-57200-23017	44	13 Learning Center Pro Shop Renovator	55,000	55,000	28,000	83,000			
100-150-57200-23016	40	15 Turf	500,000	500,000	500,000	500,000	500,000	500,000	500,000
	20	14 Burn Room Repairs	75,000	-	-				
100-140-57200-20038	29	16 Addition to Current Maintenance Shop	400,000	-	-				
	64	17 Safe Streets & Roads for All Safety Study	500,000	400,000	400,000	100,000			
	17	18 Police Impound Yard Improvements	650,000	-	-				
	16	19 Heavy Duty/High Functioning Drone	50,000	-	-				
	36	20 Hanover Park Tennis Court	400,000	-	-				
	63	21 8th Street Intersection Improvements	2,000,000	-	-				
	31	22 Replace Lighting @ Pawnee Park Bell Towers	80,000	-	-	80,000			
	37	23 Sunset Park Trail Lighting	375,000	-	-				
		24 Downtown Traffic - Refine and Move Forward	75,000	-	-				
		25 Clubhouse Update - begin community engage	100,000	-	-				
	8	26 EV Station, Study, Design and Infrastructure	1,000,000	800,000	800,000				
		Total:		10,028,181	3,933,123				
		<i>Target:</i>		\$10,000,000	3,993,123				

ENTERPRISE FUNDS										
		City Workforce/Affordable Housing Subdivisor	500,000			500,000	500,000			
500-500-57510-21097	72	23rd Street Reconstruction	257,000			257,000	257,000			
500-500-57300-20091	73	North Sanitary Sewer Collection System Impr.	600,000			600,000	600,000			
500-500-57300-20093	74	Lift Station Renovation LS #15 Westbrook	425,000			425,000	425,000			
500-500-57300-20094	75	System CIP Lining	150,000			150,000	150,000	150,000	175,000	175,000
500-500-57300-21081	76	Design 25th St & 35th Ave Lift Station repairs	750,000			750,000	750,000			
	77	Sewer Main Sunset Park	100,000			-	-	100,000		
		Total for Wastewater Collection	2,282,000			2,182,000	2,182,000	150,000	175,000	175,000
		Total for Wastewater Treatment	-			-	-	-	-	-
		City Workforce/Affordable Housing Subdivisor	500,000			500,000	500,000			
520-520-57200-22031	78	Water Extension Design & Construction - 18th	1,250,000			1,250,000	1,250,000			
520-520-57300-21095	79	23rd Street Water Main Reconstruction	372,000			372,000	372,000			
	80	Update Security Cameras	20,000			20,000	20,000	36,000	36,000	36,000
520-520-57510-21027	81	3 Million Gallon Storage Tank Rehab	200,000			200,000	200,000			
520-520-57510-23042	82	Water Sys Hydraulic & Rate Study	75,000			75,000	75,000			
	83	Replace Unit 86	45,000			45,000	45,000			
	84	Water Main Sunset Park Loop	250,000			-	-	250,000		
	85	Contractor Fill Station	37,000			37,000	37,000			
	86	Purchase & Improvements of NDOT Shop & Y	2,000,000			-	-			
	87	Water WWTF, Quail Run & Res Dev. Loop	750,000			-	-	750,000		
		Total for Water	4,999,000			1,999,000	1,999,000	1,036,000	36,000	36,000
560-560-57300-20107	88	Storm Water & Flood Evaluation and Improver	125,000			125,000	125,000	125,000	125,000	150,000
	89	STF Bank Design and Construction	500,000			500,000	500,000			
560-560-57510-21096	90	Trunk Line Storm Sewer Cleaning	50,000			50,000	50,000	50,000	60,000	65,000
		Total for Stormwater Utility	675,000			675,000	675,000	125,000	125,000	150,000
	91	Load Out Bay Repairs	40,000			40,000	40,000			
	92	Loader Bucket & Grapple	25,000			25,000	25,000			
	93	Semi	175,000			175,000	175,000			
570-570-57510-23045	94	Trailers to replace unsafe trailers	150,000			150,000	150,000			
		Transfer Station	390,000			390,000	390,000	-	-	-

10.A.1.e. Budget.

Calculations as of 09/30/2023

ACCOUNT	DESCRIPTION	2020-21 ACTIVITY	2021-22 ACTIVITY	2022-23 ACTIVITY THRU 09/30/23	2023-24 FINANCE REVIEW BUDGET
Dept 100 - GENERAL ADMINISTRATION					
ESTIMATED REVENUES					
41100	PROPERTY TAX	5,058,404	5,409,381	3,890,604	5,864,665
41120	MOTOR VEHICLE TAX	644,419	627,228	521,852	625,000
41820	OCCUPATION/FRANCHISE TAX	632,322	642,998	570,591	650,000
42101	LIQUOR AND BEER LICENSES	17,490	32,540	31,705	31,500
42120	OTHER LICENSES	7,025	7,550	7,275	7,500
42175	WIRELESS PERMITS	8,500	28,500	29,160	20,000
42340	CONVENIENCE FEE	448	495	1,282	500
43102	FEDERAL GRANTS			90,841	315,000
43510	MUNICIPAL EQUALIZATION	2,538	14,185	1,473	29,984
43555	PRO-RATE MOTOR VEHICLE	13,703	15,355	12,003	12,500
43900	IN-LIEU-TAX	231,690	240,734	252,496	250,000
44115	ADMINISTRATIVE FEES	900	900	900	900
44120	PUBLICATION FEES	1,052	1,136	1,115	1,050
44125	RECORDING FEES	1,305	1,560	1,530	2,000
44130	ENGINEERING SERVICES	5,615	3,375	3,485	3,500
45310	BUILDING RENTALS	25	25	2,937	
45325	LAND RENTALS	23,071	33,332	21,184	23,500
46100	INTEREST	85,068	36,678	116,096	125,000
48000	MISCELLANEOUS REVENUE	25,055	5,019	9,278	5,000
48100	REFUNDS	152	2,415	1,849	500
49100	TRANSFERS IN	4,394,486	9,823,035	5,528,544	8,095,676
49210	LAND OR PROPERTY SALES	39,502	22,765	8,731	
TOTAL ESTIMATED REVENUES		11,192,770	16,949,206	11,104,931	16,063,775
APPROPRIATIONS					
51100	SALARIES AND WAGES	67,004	44,188	78,478	91,020
51200	OVERTIME	27		6	
51300	TEMPORARY AND SEASONAL	7,961	12,845	6,140	3,500
52100	SOCIAL SECURITY	5,974	9,106	6,536	7,255
52200	GROUP INSURANCE	15,511	13,452	12,663	14,550
52300	RETIREMENT	4,279	4,831	4,196	5,485
52600	WORKERS' COMPENSATION	153	8,949	10,305	10,500
52700	TRAINING AND TUITION	(56)	413	1,059	500
52710	EMPLOYEE RECRUITMENT/RETENTION	1,254	20,155	10,323	15,000
52800	UNIFORMS		155	94	200
53100	ENGINEERING SERVICES				20,000
53200	PROFESSIONAL SERVICES	119,811	147,472	158,245	200,000
53300	RISK MANAGEMENT				1,000
53400	COMPUTER SUPPORT/MAINT	117,718	67,221	105,671	120,000
54310	BUILDING MAINTENANCE	10,535	3,287	6,469	10,000
54320	EQUIPMENT MAINTENANCE	1,992	134	73	2,000
54330	VEHICLE MAINTENANCE	309	835	51	250
54380	MAINTENANCE AGREEMENTS			532	
54510	BUILDING RENTAL/LEASE	2,960		3,140	3,050
55200	INSURANCE	16,589	14,302	60,145	40,000
55210	CLAIMS AND SETTLEMENTS			42	
55500	PUBLICATIONS AND NOTICES	9,169	16,745	18,242	15,000
55600	ELECTION EXPENSE	2,619	100	671	
55900	MISCELLANEOUS	229,746	9,191	10,939	10,000
55920	MISC FEES	3,874	6,647	8,817	7,000
55950	COVID-19 EXPENSES	45			
56010	SUPPLIES	2,503	2,226	5,005	2,500
56020	OFFICE SUPPLIES	8,516	7,393	8,973	8,000
56030	CLEANING SUPPLIES/SERVICE	24,619	23,043	23,817	22,500
56040	POSTAGE AND FREIGHT	7,539	9,211	7,866	10,000
56050	FUEL	959	1,182	1,922	2,000
56210	NATURAL GAS	10	83		
56220	ELECTRICITY	29,486	19,169	18,572	25,000
56230	WATER AND SEWER	5,886	6,741	1,809	2,500
56240	TELEPHONE	6,403	4,613	9,382	11,000
56250	REFUSE	1,985	1,784	2,576	3,000
56410	BOOKS AND PUBLICATIONS	15,943	20,181	5,154	20,000
56610	CHAMBER OF COMMERCE	10,000	10,500	10,500	10,500
56620	EMERGENCY MANAGEMENT	15,135	6,402	5,684	7,500
56650	MEMBERSHIP DUES	103,725	75,349	42,665	75,000
56690	SALES TAX REMITTANCE	21	10	10	
57200	CAPITAL-LAND & BUILDINGS	504,447		3,252,159	1,485,230
57510	CAPITAL-EQUIPMENT	5,831		341,293	1,138,200
57950	DEPRECIATION		569,708		
58100	TRANSFERS OUT	489,145	480,000	400,000	11,694,800
TOTAL APPROPRIATIONS		1,849,627	1,617,623	4,640,224	15,094,040
NET OF REVENUES/APPROPRIATIONS - 100 - GENERAL ADMINI		9,343,143	15,331,583	6,464,707	969,735

Calculations as of 09/30/2023

ACCOUNT	DESCRIPTION	2020-21 ACTIVITY	2021-22 ACTIVITY	2022-23 ACTIVITY THRU 09/30/23	2023-24 FINANCE REVIEW BUDGET
Dept 102 - COLUMBUS AREA TRANSIT					
ESTIMATED REVENUES					
43102	FEDERAL GRANTS	188,884	152,588	100,725	160,000
43530	SOCIAL SERVICES REIMBURSE			250	
44780	SALES OF TICKETS-BUS	11,010	12,420	12,312	13,000
47510	DONATIONS-UNITED WAY	3,500			
48000	MISCELLANEOUS REVENUE	1,943			
48100	REFUNDS	300			
49100	TRANSFERS IN		23,878		87,410
49210	LAND OR PROPERTY SALES			8,480	
TOTAL ESTIMATED REVENUES		205,637	188,886	121,767	260,410
APPROPRIATIONS					
51100	SALARIES AND WAGES	96,097	153,013	128,488	149,350
51200	OVERTIME	122	505	226	210
51300	TEMPORARY AND SEASONAL	39	39		
52100	SOCIAL SECURITY	8,643	9,798	9,095	11,450
52200	GROUP INSURANCE	35,390	29,615	29,968	43,730
52300	RETIREMENT	7,113	8,266	6,527	8,960
52500	UNEMPLOYMENT	152			
52600	WORKERS' COMPENSATION	1,747	2,115	1,395	1,500
52700	TRAINING AND TUITION	453			300
52710	EMPLOYEE RECRUITMENT/RETENTION	773	235	130	300
52800	UNIFORMS		334		300
53400	COMPUTER SUPPORT/MAINT	4,184	5,888	4,781	1,500
54310	BUILDING & GROUNDS MAINT	1,381	1,189	1,253	2,500
54320	EQUIPMENT MAINTENANCE	1,364	425	170	800
54330	VEHICLE MAINTENANCE	2,576	3,623	1,897	4,000
55200	INSURANCE	3,145	3,948	8,350	9,000
55400	ADVERTISING AND PROMOTION	42			
55900	MISCELLANEOUS	2,280	10		100
55930	REFUNDS	50			50
55950	COVID-19 EXPENSES	173			
56010	SUPPLIES	168		10	250
56020	OFFICE SUPPLIES	911	841	670	1,000
56030	CLEANING SUPPLIES/SERVICE	389	290	342	400
56040	POSTAGE AND FREIGHT	1	1		10
56050	FUEL	5,870	9,349	5,202	9,000
56210	NATURAL GAS	1,338	1,710	1,866	2,000
56220	ELECTRICITY	1,333	1,302	968	1,500
56230	WATER AND SEWER	1,123	1,156	967	1,200
56240	TELEPHONE	921	848	768	1,000
56650	MEMBERSHIP DUES	105			
57510	CAPITAL-EQUIPMENT				10,000
57950	DEPRECIATION		48,527		
TOTAL APPROPRIATIONS		177,883	283,027	203,073	260,410
NET OF REVENUES/APPROPRIATIONS - 102 - COLUMBUS AREA		27,754	(94,141)	(81,306)	

Calculations as of 09/30/2023

ACCOUNT	DESCRIPTION	2020-21 ACTIVITY	2021-22 ACTIVITY	2022-23 ACTIVITY THRU 09/30/23	2023-24 FINANCE REVIEW BUDGET
Dept 103 - COLUMBUS SENIOR CENTER					
ESTIMATED REVENUES					
43105	NENAAA - SENIOR CENTER	96,573	121,601	107,069	163,500
43530	SOCIAL SERVICES REIMBURSE	13,904	11,717	15,044	17,000
44743	MEALS - CONGREGATE	37,297	54,513	54,688	70,000
44744	MEALS-HOME DELIVERED	54,892	35,406	43,089	40,000
44746	MEALS - CURBSIDE TO GO		3,579	7,664	5,000
44748	MEALS - COVID		500		
44749	CONGREGATE MEALS INELIGIBLE			380	
45310	BUILDING RENTALS	50	636	605	1,000
47500	DONATIONS	27,909	37,351	2,687	21,500
47510	DONATIONS-UNITED WAY	10,000			
47524	CONTRIBUTIONS			1,938	2,000
47530	FUND RAISERS		219	947	700
48000	MISCELLANEOUS REVENUE	2,104	510	53,528	500
48100	REFUNDS		218	689	
49100	TRANSFERS IN		24,128	1,788	242,030
49210	LAND OR PROPERTY SALES			209	
TOTAL ESTIMATED REVENUES		242,729	290,378	290,325	563,230
APPROPRIATIONS					
51100	SALARIES AND WAGES	180,558	275,715	194,412	225,810
51200	OVERTIME		667	160	410
52100	SOCIAL SECURITY	14,809	17,129	14,476	17,460
52200	GROUP INSURANCE	50,570	44,420	30,807	35,900
52300	RETIREMENT	10,735	13,180	9,690	13,600
52500	UNEMPLOYMENT			5,867	5,880
52600	WORKERS' COMPENSATION	533			850
52700	TRAINING AND TUITION		696	111	1,290
52710	EMPLOYEE RECRUITMENT/RETENTION	1,515	2,045	820	300
53200	PROFESSIONAL SERVICES		338		100
53400	COMPUTER SUPPORT/MAINT	484	2,237	4,306	3,700
53520	CONTRACT SERVICES		189		
54310	BUILDING & GROUNDS MAINT	59	183	1,326	500
54320	EQUIPMENT MAINTENANCE	969	4,489	3,731	2,000
54510	BUILDING RENTAL/LEASE	111,191	1	104,171	121,750
55200	INSURANCE	1,226	394	456	840
55400	ADVERTISING AND PROMOTION	30	30		
55900	MISCELLANEOUS	1,479	796	1,147	750
56010	SUPPLIES	11,579	13,395	16,699	12,990
56020	OFFICE SUPPLIES	660	2,126	2,073	2,000
56030	CLEANING SUPPLIES/SERVICE	1,443	2,210	2,127	2,250
56040	POSTAGE AND FREIGHT	17	42	26	100
56240	TELEPHONE	423	342	366	550
56300	FOOD COSTS	67,144	87,844	76,356	100,000
56400	PROGRAMS	754	795	718	2,000
56650	MEMBERSHIP DUES	11,824	11,751	12,336	12,200
57200	CAPITAL-LAND & BUILDINGS			6,198	
57950	DEPRECIATION	8,039	7,341		
TOTAL APPROPRIATIONS		476,041	488,355	488,379	563,230
NET OF REVENUES/APPROPRIATIONS - 103 - COLUMBUS SENIC		(233,312)	(197,977)	(198,054)	

Calculations as of 09/30/2023

ACCOUNT	DESCRIPTION	2020-21 ACTIVITY	2021-22 ACTIVITY	2022-23 ACTIVITY THRU 09/30/23	2023-24 FINANCE REVIEW BUDGET
Dept 104 - CITY ADMINISTRATOR					
ESTIMATED REVENUES					
43710	LOCAL GRANTS			12,095	
48000	MISCELLANEOUS REVENUE	2,719			
49100	TRANSFERS IN				602,300
TOTAL ESTIMATED REVENUES		2,719		12,095	602,300
APPROPRIATIONS					
51100	SALARIES AND WAGES	267,883	390,267	377,574	435,210
51200	OVERTIME	46	5		
52100	SOCIAL SECURITY	19,101	21,267	25,064	33,310
52200	GROUP INSURANCE	62,681	72,294	83,834	94,610
52300	RETIREMENT	21,767	25,625	25,860	26,120
52600	WORKERS' COMPENSATION	159			250
52700	TRAINING AND TUITION	1,238	289	2,785	3,000
52710	EMPLOYEE RECRUITMENT/RETENTION	2,836	225		500
55900	MISCELLANEOUS	9,000	6,600	6,750	7,800
56240	TELEPHONE			20	
56650	MEMBERSHIP DUES	100			1,500
57950	DEPRECIATION	990	496		
TOTAL APPROPRIATIONS		385,801	517,068	521,887	602,300
NET OF REVENUES/APPROPRIATIONS - 104 - CITY ADMINISTF		(383,082)	(517,068)	(509,792)	

Calculations as of 09/30/2023

ACCOUNT	DESCRIPTION	2020-21 ACTIVITY	2021-22 ACTIVITY	2022-23 ACTIVITY THRU 09/30/23	2023-24 FINANCE REVIEW BUDGET
Dept 105 - FINANCE					
ESTIMATED REVENUES					
48000	MISCELLANEOUS REVENUE	223			
49100	TRANSFERS IN				557,170
TOTAL ESTIMATED REVENUES		223			557,170
APPROPRIATIONS					
51100	SALARIES AND WAGES	302,144	344,912	342,499	407,730
51200	OVERTIME	3,094	1,103	1,478	1,690
52100	SOCIAL SECURITY	26,509	27,511	25,427	31,330
52200	GROUP INSURANCE	69,050	77,636	69,388	79,600
52300	RETIREMENT	20,929	22,605	17,481	24,570
52600	WORKERS' COMPENSATION	191			200
52700	TRAINING AND TUITION	1,235	1,165	521	1,500
52710	EMPLOYEE RECRUITMENT/RETENTION	1,303	1,270	323	1,000
53400	COMPUTER SUPPORT/MAINT	4,396	10,136	1,989	4,000
55900	MISCELLANEOUS	3,200	3,000	2,750	3,000
56240	TELEPHONE	1,778	1,797	2,230	1,800
56650	MEMBERSHIP DUES	95	537		750
57950	DEPRECIATION	2,439	1,028		
TOTAL APPROPRIATIONS		436,363	492,700	464,086	557,170
NET OF REVENUES/APPROPRIATIONS - 105 - FINANCE		(436,140)	(492,700)	(464,086)	

Calculations as of 09/30/2023

ACCOUNT	DESCRIPTION	2020-21 ACTIVITY	2021-22 ACTIVITY	2022-23 ACTIVITY THRU 09/30/23	2023-24 FINANCE REVIEW BUDGET
Dept 106 - CITY CLERK					
ESTIMATED REVENUES					
48000	MISCELLANEOUS REVENUE	(170)			
49100	TRANSFERS IN				318,350
TOTAL ESTIMATED REVENUES		(170)			318,350
APPROPRIATIONS					
51100	SALARIES AND WAGES	131,363	185,242	179,297	208,430
51200	OVERTIME	516	589	845	1,030
52100	SOCIAL SECURITY	13,121	14,945	12,722	16,030
52200	GROUP INSURANCE	59,994	57,872	57,640	65,800
52300	RETIREMENT	10,756	12,494	9,091	12,570
52600	WORKERS' COMPENSATION	130			200
52700	TRAINING AND TUITION	420	3,816	3,002	9,000
52710	EMPLOYEE RECRUITMENT/RETENTION	186	890	77	500
53400	COMPUTER SUPPORT/MAINT	2,225	2,318	2,062	2,000
55200	INSURANCE	662			750
56010	SUPPLIES	473	15		500
56020	OFFICE SUPPLIES	79			500
56240	TELEPHONE	325	337	322	350
56650	MEMBERSHIP DUES	325	360	815	690
57950	DEPRECIATION		3,263		
TOTAL APPROPRIATIONS		220,575	282,141	265,873	318,350
NET OF REVENUES/APPROPRIATIONS - 106 - CITY CLERK		(220,745)	(282,141)	(265,873)	

Calculations as of 09/30/2023

ACCOUNT	DESCRIPTION	2020-21 ACTIVITY	2021-22 ACTIVITY	2022-23 ACTIVITY THRU 09/30/23	2023-24 FINANCE REVIEW BUDGET
Dept 107 - MAYOR/COUNCIL					
ESTIMATED REVENUES					
49100	TRANSFERS IN				93,220
	TOTAL ESTIMATED REVENUES				93,220
APPROPRIATIONS					
51100	SALARIES AND WAGES	61,843	66,185	58,136	67,550
52100	SOCIAL SECURITY	4,867	5,062	4,447	5,170
52600	WORKERS' COMPENSATION	34			
52700	TRAINING AND TUITION	47	3,549	1,949	3,000
53400	COMPUTER SUPPORT/MAINT				17,000
55800	TRAVEL				500
	TOTAL APPROPRIATIONS	66,791	74,796	64,532	93,220
NET OF REVENUES/APPROPRIATIONS - 107 - MAYOR/COUNCIL		(66,791)	(74,796)	(64,532)	

Calculations as of 09/30/2023

ACCOUNT	DESCRIPTION	2020-21 ACTIVITY	2021-22 ACTIVITY	2022-23 ACTIVITY THRU 09/30/23	2023-24 FINANCE REVIEW BUDGET
Dept 108 - HUMAN RESOURCES					
ESTIMATED REVENUES					
48000	MISCELLANEOUS REVENUE	50			
49100	TRANSFERS IN				159,830
TOTAL ESTIMATED REVENUES		50			159,830
APPROPRIATIONS					
51100	SALARIES AND WAGES	98,115	236,747	110,313	128,190
52100	SOCIAL SECURITY	8,434	9,502	8,389	9,810
52200	GROUP INSURANCE	18,878	10,048	8,811	10,100
52300	RETIREMENT	6,631	7,512	5,568	7,700
52600	WORKERS' COMPENSATION	62			80
52700	TRAINING AND TUITION	70	655		1,000
52710	EMPLOYEE RECRUITMENT/RETENTION	224	113	256	250
53400	COMPUTER SUPPORT/MAINT		2,964	508	500
55900	MISCELLANEOUS		85	90	300
56240	TELEPHONE	1,035	1,515	1,320	1,500
56650	MEMBERSHIP DUES	219	344	244	400
57950	DEPRECIATION	777	139		
TOTAL APPROPRIATIONS		134,445	269,624	135,499	159,830
NET OF REVENUES/APPROPRIATIONS - 108 - HUMAN RESOURCE		(134,395)	(269,624)	(135,499)	

Calculations as of 09/30/2023

ACCOUNT	DESCRIPTION	2020-21 ACTIVITY	2021-22 ACTIVITY	2022-23 ACTIVITY THRU 09/30/23	2023-24 FINANCE REVIEW BUDGET
Dept 110 - POLICE					
ESTIMATED REVENUES					
42110	ANIMAL LICENSES	18,451	13,159	14,341	15,000
42120	OTHER LICENSES	40	45	15	50
42136	OTHER PERMITS	4,475	4,450	4,290	5,000
42310	FINES AND PENALTIES	2,461	1,036	924	1,500
42320	VEHICLE IMPOUND FEES	26,115	33,050	36,387	35,000
43102	FEDERAL GRANTS	11,859	3,456	10,566	13,200
43410	STATE GRANTS	6,416	12,287	77,415	10,000
43920	S.T.O.P. PROGRAM	400	250	250	500
44150	FUEL	29,704	40,164	28,411	30,000
44210	ALARM SYSTEMS	25	200	550	600
44215	OTHER FEES	6,676	5,190	4,094	6,000
44218	POLICE PROTECTION	66,196	97,867	106,000	110,000
44520	INSPECTION FEES		20	40	
44540	ANIMAL IMPOUNDING FEES	2,054	1,060	405	2,500
44760	COPY MACHINE FEES	5,721	5,168	5,629	6,000
47500	DONATIONS		5,307	52,816	
47520	DONATIONS-D.A.R.E.	3,726	11,154		
47521	DONATIONS-GREAT		3,618		
47523	DONATIONS - HUMAN TRAFFIC TASK FO	990			
48000	MISCELLANEOUS REVENUE	844,600	5,003	8,871	5,000
48100	REFUNDS	885	43		1,000
49100	TRANSFERS IN	543,624	369,643	519,943	5,488,330
49210	LAND OR PROPERTY SALES	137,543	37,264	66,361	
TOTAL ESTIMATED REVENUES		1,711,961	649,434	937,308	5,729,680
APPROPRIATIONS					
51100	SALARIES AND WAGES	2,332,352	3,226,650	2,659,015	3,091,680
51200	OVERTIME	141,677	153,735	137,223	161,410
51300	TEMPORARY AND SEASONAL		2,619	8,382	9,860
52100	SOCIAL SECURITY	214,807	241,065	206,986	249,620
52200	GROUP INSURANCE	725,433	738,461	652,094	743,400
52300	RETIREMENT	189,666	225,900	185,290	228,410
52500	UNEMPLOYMENT	4,170			2,500
52600	WORKERS' COMPENSATION	61,301	74,162	5,012	70,000
52700	TRAINING AND TUITION	36,679	40,577	33,430	60,000
52710	EMPLOYEE RECRUITMENT/RETENTION	11,942	12,117	4,807	12,500
52800	UNIFORMS	16,236	9,983	4,692	15,000
52810	UNIFORMS-QUARTERMASTER	28,353	22,563	14,105	25,000
53200	PROFESSIONAL SERVICES	73,812	77,496	63,481	60,000
53400	COMPUTER SUPPORT/MAINT	5,428	8,304	13,026	23,400
53520	CONTRACT SERVICES	80,000	100,000	83,355	84,000
54310	BUILDING MAINTENANCE	7,120	18,785	5,728	7,500
54320	EQUIPMENT MAINTENANCE	10,154	8,963	5,558	7,500
54330	VEHICLE MAINTENANCE	42,313	36,641	29,839	38,000
54380	MAINTENANCE AGREEMENTS	9,440	9,900	16,953	48,000
54510	BUILDING RENTAL/LEASE	1,200			1,200
54520	EQUIPMENT RENTAL/PURCHASE	2,571	3,819		4,000
54530	VEHICLE TOWING	20,744	23,853	25,888	30,000
55200	INSURANCE	34,238	44,951	116,975	50,000
55210	CLAIMS AND SETTLEMENTS	1,361	173	6,900	1,000
55900	MISCELLANEOUS	5,775	890		2,000
55950	COVID-19 EXPENSES	645			
56010	SUPPLIES	5,803	6,843	6,344	7,000
56020	OFFICE SUPPLIES	6,896	8,642	2,688	7,500
56030	CLEANING SUPPLIES/SERVICE	30,596	26,413	26,543	30,000
56040	POSTAGE AND FREIGHT	2,319	2,003	1,833	1,800
56050	FUEL	77,880	132,703	73,515	80,000
56140	STOP PROGRAM EXPENSE		3,806		2,500
56150	D.A.R.E. EXPENSE	296	1,713	1,706	3,000
56160	G.R.E.A.T. EXPENSE	55	73	105	1,500
56165	K9 PROGRAM	120	3,219	1,557	6,000
56190	PERSONAL PROTECTIVE SUPP	25,087	22,761	14,591	22,000
56210	NATURAL GAS	8,288	9,592	11,693	15,000
56220	ELECTRICITY	41,870	34,136	25,536	35,000
56230	WATER AND SEWER	1,768	2,009	1,710	2,600
56240	TELEPHONE	18,095	19,475	14,807	23,000
56250	REFUSE	888	899	1,142	1,500
56280	KIDS & COPS EXPENSES				500
56630	DRUG TASK FORCE	5,400	5,400	5,400	5,800
56650	MEMBERSHIP DUES	1,230	1,235	1,245	2,000
56680	LICENSE TAX REMITTANCE	1,351	961		1,500
56690	SALES TAX REMITTANCE	418	382	322	500
57200	CAPITAL-LAND & BUILDINGS	71,768			
57510	CAPITAL-EQUIPMENT	317,903		315,860	210,000
57520	CAPITAL-VEHICLES	203,985		206,796	245,000

Calculations as of 09/30/2023

ACCOUNT	DESCRIPTION	2020-21 ACTIVITY	2021-22 ACTIVITY	2022-23 ACTIVITY THRU 09/30/23	2023-24 FINANCE REVIEW BUDGET
Dept 110 - POLICE					
APPROPRIATIONS					
57950	DEPRECIATION		659,654		
	TOTAL APPROPRIATIONS	4,879,433	6,023,526	4,992,132	5,729,680
	NET OF REVENUES/APPROPRIATIONS - 110 - POLICE	(3,167,472)	(5,374,092)	(4,054,824)	

Calculations as of 09/30/2023

ACCOUNT	DESCRIPTION	2020-21 ACTIVITY	2021-22 ACTIVITY	2022-23 ACTIVITY THRU 09/30/23	2023-24 FINANCE REVIEW BUDGET
Dept 120 - FIRE					
ESTIMATED REVENUES					
43410	STATE GRANTS	60,000		5,100	
43710	LOCAL GRANTS		93,250	2,000	
44215	OTHER FEES	168	216	387	
44220	FIRE PROTECTION-INDUSTR	41,064	211,054	183,792	190,000
44221	FIRE PROTECTION-RURAL	45,000	45,000	45,000	45,000
44240	INSPECTION FEES	6,925	7,350	6,825	7,000
47500	DONATIONS		150	51,611	100
48000	MISCELLANEOUS REVENUE	122,388	267,403	1,613	5,000
49100	TRANSFERS IN	138,957	1,770,270	209,267	1,188,710
49210	LAND OR PROPERTY SALES		735	8,421	
TOTAL ESTIMATED REVENUES		414,502	2,395,428	514,016	1,435,810
APPROPRIATIONS					
51100	SALARIES AND WAGES	289,982	598,062	443,380	515,220
51200	OVERTIME	26,069	32,148	27,623	32,680
51300	TEMPORARY AND SEASONAL	53			
52100	SOCIAL SECURITY	7,918	9,233	8,063	9,380
52200	GROUP INSURANCE	79,397	98,678	103,595	118,600
52300	RETIREMENT	21,143	56,490	13,614	32,880
52600	WORKERS' COMPENSATION	12,232	32,943	3,015	32,950
52700	TRAINING AND TUITION	3,856	11,253	10,457	12,000
52710	EMPLOYEE RECRUITMENT/RETENTION	8,672	13,451	551	5,000
52800	UNIFORMS	7,962	5,291	5,329	7,000
52900	EMPLOYEE HEALTH	1,500	381	52	2,000
53200	PROFESSIONAL SERVICES			2,467	
53210	EQUIPMENT RECERT PROGRAM	4,300	2,904	6,187	13,000
53400	COMPUTER SUPPORT/MAINT	5,821	14,071	5,216	6,250
54310	BUILDING MAINTENANCE	19,362	14,738	6,128	10,000
54320	EQUIPMENT MAINTENANCE	16,330	4,308	949	15,000
54330	VEHICLE MAINTENANCE	23,841	24,561	68,565	40,000
54380	MAINTENANCE AGREEMENTS	900	3,466	2,880	10,000
55200	INSURANCE	35,369	34,209	61,097	31,000
55210	CLAIMS AND SETTLEMENTS		18,663		
55900	MISCELLANEOUS	1,328	833	2	1,000
55950	COVID-19 EXPENSES	569			
56010	SUPPLIES	42,704	28,320	12,130	20,000
56020	OFFICE SUPPLIES	2,622	2,139	1,723	2,500
56030	CLEANING SUPPLIES/SERVICE	4,915	4,466	3,742	5,000
56040	POSTAGE AND FREIGHT	397	43	5	150
56050	FUEL	13,466	18,966	6,524	10,000
56170	FIRE PREVENTION	3,762	1,341	66	2,000
56190	PERSONAL PROTECTIVE SUPP	40,411	27,346	11,681	
56210	NATURAL GAS	6,523	13,021	9,996	13,000
56220	ELECTRICITY	15,053	15,388	10,287	13,000
56230	WATER AND SEWER	3,491	2,667	2,606	3,000
56240	TELEPHONE	7,494	8,199	8,676	12,560
56250	REFUSE			27	
56650	MEMBERSHIP DUES	402	501	523	600
56690	SALES TAX REMITTANCE	32	18	29	40
57200	CAPITAL-LAND & BUILDINGS	(95,559)		1,091,028	
57300	CAPITAL-NEW CONSTRUCTION			110,349	
57510	CAPITAL-EQUIPMENT	18,728		135,681	300,000
57520	CAPITAL-VEHICLES			92,622	160,000
57950	DEPRECIATION		797,672		
TOTAL APPROPRIATIONS		631,045	1,895,770	2,266,865	1,435,810
NET OF REVENUES/APPROPRIATIONS - 120 - FIRE		(216,543)	499,658	(1,752,849)	

Calculations as of 09/30/2023

ACCOUNT	DESCRIPTION	2020-21 ACTIVITY	2021-22 ACTIVITY	2022-23 ACTIVITY THRU 09/30/23	2023-24 FINANCE REVIEW BUDGET
Dept 121 - RESCUE					
ESTIMATED REVENUES					
43102	FEDERAL GRANTS		10,400		
43710	LOCAL GRANTS		14,500	7,000	
44230	AMBULANCE SERVICE - BLS	326	(25,592)		
44231	AMBULANCE SERVICE - ALS 1	(105,131)	(41,528)		
44232	AMBULANCE SERVICE - ALS 2	1,504	(3,159)		
44233	AMBULANCE SERVICES	475,593	422,810	488,381	475,000
47500	DONATIONS	625		2,000	
48000	MISCELLANEOUS REVENUE	224,033	(647)	40	2,000
48100	REFUNDS	656	5	25	
49100	TRANSFERS IN	4,368	88,506	55,428	1,602,610
TOTAL ESTIMATED REVENUES		601,974	465,295	552,874	2,079,610
APPROPRIATIONS					
51100	SALARIES AND WAGES	674,667	717,939	775,748	901,620
51200	OVERTIME	48,398	59,703	51,296	60,670
52100	SOCIAL SECURITY	11,517	12,004	11,527	13,420
52200	GROUP INSURANCE	137,964	174,963	184,341	211,000
52300	RETIREMENT	36,711	102,011	22,905	57,740
52600	WORKERS' COMPENSATION	22,688	(64)	(3,101)	
52700	TRAINING AND TUITION	24,704	15,948	24,862	30,000
52710	EMPLOYEE RECRUITMENT/RETENTION	1,732	3,980		2,500
52800	UNIFORMS	4,026	5,290	5,252	6,000
52900	EMPLOYEE HEALTH	1,500	269	52	1,500
53200	PROFESSIONAL SERVICES	52,529	48,440	56,472	66,000
53210	EQUIPMENT RECERT PROGRAM		97		
53400	COMPUTER SUPPORT/MAINT	13,537	20,739	1,244	2,500
54310	BUILDING MAINTENANCE	10,638	7,627	5,527	6,000
54320	EQUIPMENT MAINTENANCE	10,185	9,469	8,509	10,000
54330	VEHICLE MAINTENANCE	11,049	11,811	20,545	20,000
54380	MAINTENANCE AGREEMENTS	900	662		
55200	INSURANCE	3,782	10,670	14,329	14,000
55900	MISCELLANEOUS	519	203		1,000
55920	MISC FEES	56	153	353	500
55930	REFUNDS	10,569	9,238	5,747	10,000
55950	COVID-19 EXPENSES	2,040			
56010	SUPPLIES	65,697	61,062	35,052	55,000
56020	OFFICE SUPPLIES	2,525	2,192	1,533	2,500
56030	CLEANING SUPPLIES/SERVICE	15,104	5,763	7,842	6,000
56040	POSTAGE AND FREIGHT	53	22		100
56050	FUEL	7,056	11,469	14,194	15,000
56190	PERSONAL PROTECTIVE SUPP	1,320	6,871	5,703	10,000
56210	NATURAL GAS	7,361	13,021	10,285	13,000
56220	ELECTRICITY	15,074	15,389	10,287	13,000
56230	WATER AND SEWER	2,702	2,664	2,606	3,000
56240	TELEPHONE	7,712	8,138	9,964	12,560
56690	SALES TAX REMITTANCE	11	8	1	
57510	CAPITAL-EQUIPMENT			66,071	35,000
57520	CAPITAL-VEHICLES				500,000
57950	DEPRECIATION		97,721		
59999	BAD DEBT EXPENSE	53,500	(36,500)		
TOTAL APPROPRIATIONS		1,257,826	1,398,972	1,349,146	2,079,610
NET OF REVENUES/APPROPRIATIONS - 121 - RESCUE		(655,852)	(933,677)	(796,272)	

Calculations as of 09/30/2023

ACCOUNT	DESCRIPTION	2020-21 ACTIVITY	2021-22 ACTIVITY	2022-23 ACTIVITY THRU 09/30/23	2023-24 FINANCE REVIEW BUDGET
Dept 125 - VOLUNTEER FIRE DEPARTMENT					
ESTIMATED REVENUES					
48000	MISCELLANEOUS REVENUE	180			
49100	TRANSFERS IN				163,100
TOTAL ESTIMATED REVENUES		180			163,100
APPROPRIATIONS					
51100	SALARIES AND WAGES	45,826	51,567	91,937	108,000
52100	SOCIAL SECURITY	1,580	1,063	2,884	8,270
52200	GROUP INSURANCE	197	5,945	10,531	12,100
52300	RETIREMENT	1,889	4,429	1,845	6,490
52600	WORKERS' COMPENSATION	1,424	2,539		2,540
52700	TRAINING AND TUITION	7,236	6,368	9,336	15,000
52800	UNIFORMS	1,191	428	1,755	3,500
52900	EMPLOYEE HEALTH	3,431	2,153	1,760	2,500
54330	VEHICLE MAINTENANCE	6			
55200	INSURANCE	7,739	260	1,797	2,000
55900	MISCELLANEOUS	313	152	133	
56010	SUPPLIES	1,116	412	801	1,500
56020	OFFICE SUPPLIES	324	219		
56350	COMPANY EXPENSES	2,148	2,171		
56360	DEPARTMENT EXPENSES	4,991	5,346		
56650	MEMBERSHIP DUES	846	731	60	1,200
TOTAL APPROPRIATIONS		80,257	83,783	122,839	163,100
NET OF REVENUES/APPROPRIATIONS - 125 - VOLUNTEER FIRE		(80,077)	(83,783)	(122,839)	

Calculations as of 09/30/2023

ACCOUNT	DESCRIPTION	2020-21 ACTIVITY	2021-22 ACTIVITY	2022-23 ACTIVITY THRU 09/30/23	2023-24 FINANCE REVIEW BUDGET
Dept 130 - LIBRARY					
ESTIMATED REVENUES					
42310	FINES AND PENALTIES	4,868	6,647	4,863	5,000
43102	FEDERAL GRANTS	15,019	3,340	2,101	2,000
43410	STATE GRANTS	376,000	1,131	3,030	1,000
43420	STATE AID	6,067	5,835	4,796	5,800
43710	LOCAL GRANTS			3,000	
44127	MAKERSPACE FEES	92	264	131	200
44727	PROGRAMS		974	628	
44729	MERCH/MISC SALES	82	125	56	200
44760	COPY MACHINE FEES	4,457	4,979	3,941	4,500
44761	REFERENCE FEES	245	583	490	500
44764	LENDER COMPENSATION	1,442	2,529	3,306	1,500
44765	LIBRARY CARDS	1,240	1,825	1,202	1,600
46100	INTEREST	2,591			
47500	DONATIONS	3,552	562	2,261	500
47530	FUND RAISERS	20,000			
48000	MISCELLANEOUS REVENUE	14,627	468	410	250
48100	REFUNDS	964		16	
49100	TRANSFERS IN	2,555,999	11,326,778	8,282,305	1,822,740
49210	LAND OR PROPERTY SALES	7,006	2,083	412	2,000
TOTAL ESTIMATED REVENUES		3,014,251	11,358,123	8,312,948	1,847,790
APPROPRIATIONS					
51100	SALARIES AND WAGES	596,494	759,005	630,247	734,300
51200	OVERTIME	859	318	547	660
51300	TEMPORARY AND SEASONAL	2,000	1,499		
52100	SOCIAL SECURITY	48,922	55,616	46,352	65,230
52200	GROUP INSURANCE	174,400	163,923	114,489	130,600
52300	RETIREMENT	34,731	40,390	27,115	44,100
52500	UNEMPLOYMENT			2,990	
52600	WORKERS' COMPENSATION	590			600
52700	TRAINING AND TUITION	2,951	6,652	5,240	7,800
52710	EMPLOYEE RECRUITMENT/RETENTION	2,427	3,013	1,796	2,500
53400	COMPUTER SUPPORT/MAINT	34,188	53,048	25,888	62,100
53410	ELECTRONIC CATALOGING	12,815	12,260	22,740	12,500
54310	BUILDING MAINTENANCE	11,267	10,855	1,283	5,000
54320	EQUIPMENT MAINTENANCE	8,364	7,002	9,745	9,200
55200	INSURANCE	13,261	11,817	13,283	13,500
55400	ADVERTISING AND PROMOTION	8,931	8,860	6,666	10,000
55900	MISCELLANEOUS	500	39		200
55950	COVID-19 EXPENSES	185			
56010	SUPPLIES	6,211	15,741	3,516	8,400
56020	OFFICE SUPPLIES	468	453	875	1,200
56030	CLEANING SUPPLIES/SERVICE	28,561	23,953	33,156	37,000
56040	POSTAGE AND FREIGHT	4,106	6,729	5,593	7,200
56050	FUEL	65		407	
56130	SUPPLIES FOR RESALE		52	52	100
56210	NATURAL GAS	5,464	784	617	
56220	ELECTRICITY	23,375	17,643	15,896	34,120
56230	WATER AND SEWER	1,590	1,183	1,091	3,000
56240	TELEPHONE	5,011	4,324	4,546	6,500
56250	REFUSE	720	624	475	850
56400	PROGRAMS	23,777	28,028	19,971	27,400
56410	BOOKS AND PUBLICATIONS	109,547	114,389	68,024	123,100
56650	MEMBERSHIP DUES	425	100		230
56690	SALES TAX REMITTANCE	280	297	399	400
57200	CAPITAL-LAND & BUILDINGS	2,637,355		6,557,587	500,000
57950	DEPRECIATION		149,237		
TOTAL APPROPRIATIONS		3,799,840	1,497,834	7,620,586	1,847,790
NET OF REVENUES/APPROPRIATIONS - 130 - LIBRARY		(785,589)	9,860,289	692,362	

Calculations as of 09/30/2023

ACCOUNT	DESCRIPTION	2020-21 ACTIVITY	2021-22 ACTIVITY	2022-23 ACTIVITY THRU 09/30/23	2023-24 FINANCE REVIEW BUDGET
Dept 140 - CEMETERY					
ESTIMATED REVENUES					
44510	CEMETERY-LOTS	50,860	55,250	29,900	50,000
44511	GRAVE OPENINGS	33,550	33,000	23,140	30,000
44512	DEED TRANSFERS	525	550	325	400
44513	WEEKEND FEES	4,000	4,950	2,250	4,500
44514	WINTER FEES	640	1,250	850	1,250
44515	STONE SETTING FEES	1,850	90	1,675	2,500
48000	MISCELLANEOUS REVENUE	730			1,000
49100	TRANSFERS IN		23,860	1,730	95,990
TOTAL ESTIMATED REVENUES		92,155	118,950	59,870	185,640
APPROPRIATIONS					
51100	SALARIES AND WAGES	48,409	89,455	86,395	104,040
51200	OVERTIME	1,110	2,235	1,006	1,210
51300	TEMPORARY AND SEASONAL	34,763	36,309	21,187	23,190
52100	SOCIAL SECURITY	8,626	9,306	8,239	9,830
52200	GROUP INSURANCE	11,329	12,736	9,238	10,950
52300	RETIREMENT	4,591	5,217	4,434	7,710
52500	UNEMPLOYMENT	1,162	578	3,155	600
52600	WORKERS' COMPENSATION	1,759	1,716	1,735	2,000
52700	TRAINING AND TUITION			800	500
52710	EMPLOYEE RECRUITMENT/RETENTION	579	391	488	500
53400	COMPUTER SUPPORT/MAINT		1,467	3,233	1,000
53520	CONTRACT SERVICES	1,833	1,758	1,465	1,760
54310	BUILDING MAINTENANCE	375	700	281	1,000
54320	EQUIPMENT MAINTENANCE	1,980	5,593	1,175	2,000
54330	VEHICLE MAINTENANCE	110	618	499	500
55200	INSURANCE	1,989	2,054	4,718	4,800
55900	MISCELLANEOUS	214	86	12	250
55930	REFUNDS	1,165			
56010	SUPPLIES	609	887	43	1,500
56020	OFFICE SUPPLIES	63			50
56040	POSTAGE AND FREIGHT	1			
56050	FUEL	5,834	7,088	4,643	7,500
56080	PLANTS SOD SEED FLOWERS	146	1,152		1,000
56220	ELECTRICITY	1,374	1,572	1,811	2,000
56230	WATER AND SEWER	314	319	262	500
56240	TELEPHONE	597	599	484	750
56250	REFUSE	1,558	17	15	500
57200	CAPITAL-LAND & BUILDINGS			1,730	
57950	DEPRECIATION		14,987		
TOTAL APPROPRIATIONS		130,490	196,840	157,048	185,640
NET OF REVENUES/APPROPRIATIONS - 140 - CEMETERY		(38,335)	(77,890)	(97,178)	

Calculations as of 09/30/2023

ACCOUNT	DESCRIPTION	2020-21 ACTIVITY	2021-22 ACTIVITY	2022-23 ACTIVITY THRU 09/30/23	2023-24 FINANCE REVIEW BUDGET
Dept 145 - COMMUNITY DEVELOPMENT					
ESTIMATED REVENUES					
42104	PLUMBING LICENSES	2,995	2,957	3,113	3,000
42120	OTHER LICENSES				100
42135	BUILDING PERMITS	150,718	314,557	262,266	200,000
42136	OTHER PERMITS	3,118	954	1,400	2,500
42170	PLUMBING INSPECTIONS	14,632	22,336	12,656	18,500
42176	PERMIT TO OCCUPY THE RIGHT-OF-WAY	4,750	1,500	2,250	2,500
44120	PUBLICATION FEES	55			
44125	RECORDING FEES		30		
44128	BOARD OF ADJUSTMENT FEES	500	300		350
44145	SUBDIVISION & REZONE FEES	15,250	14,200	9,000	11,000
48000	MISCELLANEOUS REVENUE	5,968	1,571	5,339	3,000
49100	TRANSFERS IN	37,505			449,610
TOTAL ESTIMATED REVENUES		235,491	358,405	296,024	690,560
APPROPRIATIONS					
51100	SALARIES AND WAGES	355,283	395,513	417,594	483,250
51200	OVERTIME	110	1,066	2,825	3,310
52100	SOCIAL SECURITY	29,593	36,333	31,077	37,230
52200	GROUP INSURANCE	110,682	60,482	66,649	75,100
52300	RETIREMENT	23,958	29,536	21,314	29,200
52600	WORKERS' COMPENSATION	3,642			4,000
52700	TRAINING AND TUITION	1,400	1,135	2,267	2,500
52710	EMPLOYEE RECRUITMENT/RETENTION	216	1,166	370	1,000
52800	UNIFORMS	494	849	908	1,000
53200	PROFESSIONAL SERVICES	1,231	4,229	19,267	8,000
53400	COMPUTER SUPPORT/MAINT	15,884	12,918	15,281	17,500
54320	EQUIPMENT MAINTENANCE	1,981	134	2,068	2,500
54330	VEHICLE MAINTENANCE	260	1,548	3,534	4,300
55200	INSURANCE	921	632	1,057	1,000
55500	PUBLICATIONS AND NOTICES	620	1,623	274	2,000
55900	MISCELLANEOUS	6,037		92	250
55920	MISC FEES		3,543	3,635	4,000
55930	REFUNDS	1,223		21	1,000
56010	SUPPLIES	547	359	455	1,000
56020	OFFICE SUPPLIES	422	987	1,236	1,200
56040	POSTAGE AND FREIGHT	551	1,193	2,412	2,000
56050	FUEL	3,151	4,687	3,871	4,500
56190	PERSONAL PROTECTIVE SUPP		29		120
56240	TELEPHONE	2,905	3,542	2,760	3,600
56250	REFUSE			49	
56650	MEMBERSHIP DUES	668	145	145	1,000
56690	SALES TAX REMITTANCE	39			
57510	CAPITAL-EQUIPMENT	37,505			
57950	DEPRECIATION		7,375		
TOTAL APPROPRIATIONS		599,323	569,024	599,161	690,560
NET OF REVENUES/APPROPRIATIONS - 145 - COMMUNITY DEVE		(363,832)	(210,619)	(303,137)	

Calculations as of 09/30/2023

ACCOUNT	DESCRIPTION	2020-21 ACTIVITY	2021-22 ACTIVITY	2022-23 ACTIVITY THRU 09/30/23	2023-24 FINANCE REVIEW BUDGET
Dept 150 - PARKS					
ESTIMATED REVENUES					
41822	LODGING TAX			220,844	350,000
42136	OTHER PERMITS	48			
43102	FEDERAL GRANTS			248,369	
43410	STATE GRANTS				280,000
43710	LOCAL GRANTS			55,514	28,000
44155	ELECTRICITY REVENUE	243	1,201		
44727	PROGRAMS	3,424	59,174	20,394	70,000
44739	TAXABLE CONCESSIONS			10,130	
44740	CONCESSIONS		19,492	18,238	20,000
45300	ATHLETIC FIELD RENTALS	12,753	5,887	14,215	64,000
45310	BUILDING RENTALS	5,516	2,739	3,252	6,000
45323	ADVERTISING	38,917	82,500	37,500	40,000
47500	DONATIONS	17,684	40,750	1,500	
48000	MISCELLANEOUS REVENUE	11,477	5,261	3,243	5,000
48100	REFUNDS		1,050	(1,000)	
49100	TRANSFERS IN	720,305	1,433,928	863,701	3,431,740
49210	LAND OR PROPERTY SALES		914	2,851	5,000
TOTAL ESTIMATED REVENUES		810,367	1,652,896	1,498,751	4,299,740
APPROPRIATIONS					
51100	CAPITAL-NEW CONSTRUCTION	500,499	533,074	619,922	716,820
51200	OVERTIME	12,187	23,771	20,034	23,980
51300	TEMPORARY AND SEASONAL	13,535	39,874	34,314	33,970
52100	SOCIAL SECURITY	45,957	54,076	50,219	59,280
52200	GROUP INSURANCE	161,756	136,840	124,453	141,700
52300	RETIREMENT	35,671	41,879	32,950	46,490
52600	WORKERS' COMPENSATION	7,019	7,017	7,268	8,000
52700	TRAINING AND TUITION	461	840	1,621	2,000
52710	EMPLOYEE RECRUITMENT/RETENTION	14,760	22,794	6,323	19,500
52800	UNIFORMS	868	616	1,875	2,000
53200	PROFESSIONAL SERVICES		10,294	3,708	5,000
53400	COMPUTER SUPPORT/MAINT	5,489	25,574	11,539	15,000
54310	BUILDING MAINTENANCE	44,206	54,225	29,568	30,000
54320	EQUIPMENT MAINTENANCE	19,634	20,736	23,711	20,000
54330	VEHICLE MAINTENANCE	4,615	3,550	1,101	5,000
54490	IRRIGATION MAINTENANCE	3,370	7,185	5,832	6,000
54520	EQUIPMENT RENTAL/PURCHASE	516	8,660	9,506	1,500
55200	INSURANCE	40,310	49,508	72,835	75,000
55210	CLAIMS AND SETTLEMENTS	6,400		3,368	1,000
55400	ADVERTISING AND PROMOTION	1,335	4,841		2,000
55900	MISCELLANEOUS	16,964	2,850	825	1,000
55910	OVER/SHORT		20	(71)	
55920	MISC FEES	32	22		50
55930	REFUNDS	60			50
56010	SUPPLIES	19,217	25,073	17,867	23,000
56020	OFFICE SUPPLIES	7	190	416	300
56040	POSTAGE AND FREIGHT	131	40	41	100
56050	FUEL	20,691	30,634	20,529	25,000
56070	FERTILIZER		21		1,000
56080	PLANTS SOD SEED FLOWERS	10,494	679	4,112	5,000
56190	PERSONAL PROTECTIVE SUPP		63		
56210	NATURAL GAS	1,819	2,140	2,695	3,000
56220	ELECTRICITY	41,968	55,626	32,791	50,000
56230	WATER AND SEWER	38,349	39,874	30,314	30,000
56240	TELEPHONE	2,564	2,916	2,882	3,500
56250	REFUSE	4,191	4,559	3,024	3,500
56300	FOOD COSTS		33,624	10,211	20,000
56400	PROGRAMS	7,668	61,585	64,006	50,000
56650	MEMBERSHIP DUES	15			
56690	SALES TAX REMITTANCE			693	
57200	CAPITAL-LAND & BUILDINGS	72,487		568,433	2,270,000
57300	CAPITAL-NEW CONSTRUCTION	(9)		154,607	500,000
57510	CAPITAL-EQUIPMENT	(11,871)		53,256	100,000
57520	CAPITAL-VEHICLES	39,877			
57950	DEPRECIATION		512,904		
TOTAL APPROPRIATIONS		1,183,242	1,818,174	2,026,778	4,299,740
NET OF REVENUES/APPROPRIATIONS - 150 - PARKS		(372,875)	(165,278)	(528,027)	

Calculations as of 09/30/2023

ACCOUNT	DESCRIPTION	2020-21 ACTIVITY	2021-22 ACTIVITY	2022-23 ACTIVITY THRU 09/30/23	2023-24 FINANCE REVIEW BUDGET
Dept 151 - PAWNEE PLUNGE WATER PARK					
ESTIMATED REVENUES					
44717	PASSES	100,083	88,939	73,355	90,000
44720	ADMISSIONS	255,719	266,246	296,644	260,000
44721	SWIMMING LESSONS	60			
44725	UNIFORMS	1,816	1,508	4,775	2,000
44726	FLOW RIDER ADMISSIONS	16,137	11,835	12,018	15,000
44727	PROGRAMS		75	375	1,000
44729	MERCH/MISC SALES	779	163	468	1,000
44739	TAXABLE CONCESSIONS			72,142	75,000
44740	CONCESSIONS	124,456	117,467	43,080	52,000
45310	BUILDING RENTALS	550	2,403	3,996	3,000
45320	EQUIPMENT RENTALS	1,182	1,079	184	1,000
47500	DONATIONS			150	
48000	MISCELLANEOUS REVENUE	755	340	444	500
48100	REFUNDS	1,696			
49100	TRANSFERS IN	135,261	79,844	77,113	321,420
TOTAL ESTIMATED REVENUES		638,494	569,899	584,744	821,920
APPROPRIATIONS					
51100	SALARIES AND WAGES	63,880	106,638	88,824	102,710
51200	OVERTIME	11,963	19,837	15,424	16,900
51300	TEMPORARY AND SEASONAL	193,912	240,608	308,422	300,440
52100	SOCIAL SECURITY	21,256	27,169	31,433	32,140
52200	GROUP INSURANCE	21,848	22,154	21,787	24,500
52300	RETIREMENT	4,728	6,434	4,680	7,180
52600	WORKERS' COMPENSATION	156	6,152	481	8,000
52700	TRAINING AND TUITION	1,719	800	4,975	2,000
52710	EMPLOYEE RECRUITMENT/RETENTION	4,419	8,085	6,669	5,000
52800	UNIFORMS	3,454		11,083	5,000
53200	PROFESSIONAL SERVICES	723	3,487	385	3,500
53400	COMPUTER SUPPORT/MAINT	1,524	7,841	4,268	6,000
54310	BUILDING MAINTENANCE	35,226	20,587	4,931	25,000
54320	EQUIPMENT MAINTENANCE	3,309	7,168	12,850	10,000
54330	VEHICLE MAINTENANCE		30		
54520	EQUIPMENT RENTAL/PURCHASE	374	1,961	3,451	15,000
55200	INSURANCE	14,941	4,036	17,474	17,500
55400	ADVERTISING AND PROMOTION	13,810	10,988		
55900	MISCELLANEOUS	508		513	100
55910	OVER/SHORT	34	4	(177)	100
55920	MISC FEES	5,248	4,843	8,109	2,750
56010	SUPPLIES	7,622	6,775	3,880	6,000
56020	OFFICE SUPPLIES	840	37	995	1,000
56030	CLEANING SUPPLIES/SERVICE	3,804	2,434	1,752	2,500
56040	POSTAGE AND FREIGHT	27			
56060	CHEMICALS	16,726	25,707	37,582	25,000
56090	SMALL TOOLS	1,002	112	44	100
56130	SUPPLIES FOR RESALE	328		239	500
56190	PERSONAL PROTECTIVE SUPP	90		47	
56210	NATURAL GAS	12,681	25,667	8,229	25,000
56220	ELECTRICITY	46,075	41,782	25,736	42,000
56230	WATER AND SEWER	8,997	8,325	9,903	7,500
56240	TELEPHONE	1,050	985	1,024	1,500
56250	REFUSE			15	
56300	FOOD COSTS	60,890	62,491	51,399	65,000
56400	PROGRAMS			600	1,000
56690	SALES TAX REMITTANCE	34,255	30,767	29,501	31,000
57510	CAPITAL-EQUIPMENT	36,268		77,113	30,000
57950	DEPRECIATION		457,839		
58100	TRANSFERS OUT	4,679			
TOTAL APPROPRIATIONS		638,366	1,161,743	793,641	821,920
NET OF REVENUES/APPROPRIATIONS - 151 - PAWNEE PLUNGE		128	(591,844)	(208,897)	

Calculations as of 09/30/2023

ACCOUNT	DESCRIPTION	2020-21 ACTIVITY	2021-22 ACTIVITY	2022-23 ACTIVITY THRU 09/30/23	2023-24 FINANCE REVIEW BUDGET
Dept 152 - AQUATIC CENTER POOL					
ESTIMATED REVENUES					
43710	LOCAL GRANTS			8,953	
44717	PASSES	18,464	17,541	20,783	18,000
44720	ADMISSIONS	10,658	12,346	12,949	10,000
44721	SWIMMING LESSONS	22,620	3,850	43,098	35,000
44724	LIFEGUARD/WSI CLASSES	6,140	2,275	8,660	6,000
44725	UNIFORMS	187	106	298	250
44727	PROGRAMS	2,635	10,002	5,427	7,000
44729	MERCH/MISC SALES	220	145	242	500
45310	BUILDING RENTALS	28,417	3,305	20,330	25,000
45320	EQUIPMENT RENTALS	693	141	163	500
48000	MISCELLANEOUS REVENUE	542	15		200
48100	REFUNDS	84			
49100	TRANSFERS IN	461,632		11,315	368,300
TOTAL ESTIMATED REVENUES		552,292	49,726	132,218	470,750
APPROPRIATIONS					
51100	SALARIES AND WAGES	160,380	45,707	93,311	107,920
51200	OVERTIME	5,142	4,429	3,711	4,200
51300	TEMPORARY AND SEASONAL	58,635	59,477	100,418	112,740
52100	SOCIAL SECURITY	18,167	17,464	14,859	17,210
52200	GROUP INSURANCE	52,739	38,432	24,014	27,100
52300	RETIREMENT	9,091	10,448	4,952	6,730
52500	UNEMPLOYMENT	(342)		12,740	
52600	WORKERS' COMPENSATION	4,004			
52700	TRAINING AND TUITION	1,293	4,694	1,653	3,500
52710	EMPLOYEE RECRUITMENT/RETENTION	2,277	267	521	1,000
52800	UNIFORMS	225		1,547	500
53200	PROFESSIONAL SERVICES	954	2,737	1,290	1,000
53400	COMPUTER SUPPORT/MAINT	1,550	130	3,336	5,000
54310	BUILDING MAINTENANCE	21,884	19,537	20,852	15,000
54320	EQUIPMENT MAINTENANCE	3,559	493	3,355	11,500
54510	BUILDING RENTAL/LEASE	1	1	1	
54520	EQUIPMENT RENTAL/PURCHASE	564	143	904	1,500
55200	INSURANCE	6,353	4,872	3,595	4,000
55400	ADVERTISING AND PROMOTION	11,250	12,000		
55900	MISCELLANEOUS	2,558	1,900	1,289	100
55910	OVER/SHORT	17			100
55920	MISC FEES	1,363	4,828	1,406	2,000
55930	REFUNDS	90	150		100
56010	SUPPLIES	1,648	2,540	1,748	2,500
56020	OFFICE SUPPLIES	1,389	866	733	1,000
56030	CLEANING SUPPLIES/SERVICE	2,593	378	1,100	2,000
56040	POSTAGE AND FREIGHT	176	2	2	50
56060	CHEMICALS	5,662	10,420	3,891	5,000
56090	SMALL TOOLS	2,602	10		500
56130	SUPPLIES FOR RESALE	116			250
56200	TEACHING SUPPLIES	2,208	13	313	2,500
56210	NATURAL GAS	17,361	27,524	25,095	30,000
56220	ELECTRICITY	56,118	53,655	36,904	50,000
56230	WATER AND SEWER	4,093	4,076	3,396	5,000
56240	TELEPHONE	982	1,064	1,154	1,250
56300	FOOD COSTS		50		
56400	PROGRAMS			2,035	1,500
56690	SALES TAX REMITTANCE	3,094	3,471	3,718	3,000
57200	CAPITAL-LAND & BUILDINGS	71,256		11,315	20,000
57510	CAPITAL-EQUIPMENT			8,958	25,000
57950	DEPRECIATION		87,442		
TOTAL APPROPRIATIONS		531,052	419,220	394,116	470,750
NET OF REVENUES/APPROPRIATIONS - 152 - AQUATIC CENTEF		21,240	(369,494)	(261,898)	

Calculations as of 09/30/2023

ACCOUNT	DESCRIPTION	2020-21 ACTIVITY	2021-22 ACTIVITY	2022-23 ACTIVITY THRU 09/30/23	2023-24 FINANCE REVIEW BUDGET
Dept 155 - VAN BERG GOLF COURSE					
ESTIMATED REVENUES					
41320	CITY & STATE SALES TAX	9,386	9,832	11,194	9,000
41340	SALES TAX FROM GOLF PRO	1,807	2,226	1,303	1,500
44710	CART RENTALS	46,491	49,288	58,157	50,000
44711	PULL CART RENTALS			359	
44713	FOOTGOLF	1,487	498	266	500
44715	GREEN FEES	68,184	68,881	76,258	70,000
44716	PUNCH CARDS	3,886	2,130	3,305	4,000
44717	PASSES	14,032	19,657	21,600	25,000
44740	CONCESSIONS	714	79	41	500
44742	LIQUOR REVENUE	13,316	21,729	10,575	13,000
48000	MISCELLANEOUS REVENUE	2,308	1,000	950	1,000
49100	TRANSFERS IN		6,800	52,890	226,510
TOTAL ESTIMATED REVENUES		161,611	182,120	236,898	401,010
APPROPRIATIONS					
51100	SALARIES AND WAGES	45,201	61,037	47,594	55,740
51200	OVERTIME	2,291	1,894	664	820
51300	TEMPORARY AND SEASONAL	21,638	23,022	26,786	31,040
52100	SOCIAL SECURITY	5,910	6,343	5,354	6,710
52200	GROUP INSURANCE	25,177	25,150	18,842	22,000
52300	RETIREMENT	3,482	3,915	2,469	3,400
52600	WORKERS' COMPENSATION	35			
52700	TRAINING AND TUITION	90	175	230	200
52710	EMPLOYEE RECRUITMENT/RETENTION	229	461	576	500
53400	COMPUTER SUPPORT/MAINT	90	956	4	1,000
53500	COMMISSION ON CARTS	4,658	4,929	7,474	5,500
53510	COMMISSION ON LIQUOR	7,253	7,619	3,606	8,000
53520	CONTRACT SERVICES	25,626	25,740	22,647	28,000
53530	COMMISSION ON GREEN FEES	3,310	3,218	6,470	4,200
53540	COMMISSION ON PASSES	631	885	2,700	2,500
54310	BUILDING MAINTENANCE	1,994	5,066	113	3,500
54320	EQUIPMENT MAINTENANCE	8,286	11,850	8,971	8,000
54330	VEHICLE MAINTENANCE		923	195	500
54350	GOLF CART/COURSE MAINT	1,452	6,284	7,423	7,500
54490	IRRIGATION MAINTENANCE	2,411	2,582	2,387	2,500
54520	EQUIPMENT RENTAL/PURCHASE	785	5,040	300	2,000
55200	INSURANCE	4,175	2,975	3,378	3,400
55400	ADVERTISING AND PROMOTION	599	1,402		
55900	MISCELLANEOUS				200
55920	MISC FEES	25	265	692	750
56010	SUPPLIES	2,099	2,200	2,297	2,000
56020	OFFICE SUPPLIES	19		9	50
56050	FUEL	5,885	5,831	4,146	7,500
56060	CHEMICALS	12,300	12,000	8,048	12,000
56070	FERTILIZER	6,000	3,861	2,957	6,000
56080	PLANTS SOD SEED FLOWERS	1,200	1,133		500
56110	PRO-SHOP SUPPLIES	784	666	166	750
56190	PERSONAL PROTECTIVE SUPP	24			500
56210	NATURAL GAS	1,827	826	974	2,000
56220	ELECTRICITY	8,382	9,566	10,896	10,000
56230	WATER AND SEWER	2,857	2,589	523	4,000
56240	TELEPHONE	292	283	329	450
56650	MEMBERSHIP DUES	150	300		300
56690	SALES TAX REMITTANCE	10,985	11,412	11,746	12,000
57200	CAPITAL-LAND & BUILDINGS				145,000
57510	CAPITAL-EQUIPMENT			52,890	
57950	DEPRECIATION		23,571		
TOTAL APPROPRIATIONS		218,152	275,969	263,856	401,010
NET OF REVENUES/APPROPRIATIONS - 155 - VAN BERG GOLF		(56,541)	(93,849)	(26,958)	

Calculations as of 09/30/2023

ACCOUNT	DESCRIPTION	2020-21 ACTIVITY	2021-22 ACTIVITY	2022-23 ACTIVITY THRU 09/30/23	2023-24 FINANCE REVIEW BUDGET
Dept 156 - QUAIL RUN GOLF COURSE					
ESTIMATED REVENUES					
41320	CITY & STATE SALES TAX	21,248	27,904	29,078	30,000
41340	SALES TAX FROM GOLF PRO	4,545	7,836	9,333	5,000
44710	CART RENTALS	92,400	122,581	128,227	120,000
44711	PULL CART RENTALS			616	
44715	GREEN FEES	111,628	155,885	149,617	150,000
44716	PUNCH CARDS	20,011	9,052	14,831	20,000
44717	PASSES	79,514	111,387	122,403	122,500
44740	CONCESSIONS	1,781	3,721	439	5,000
44741	DRIVING RANGE	3,832	4,036	258	5,000
44742	LIQUOR REVENUE	33,911	72,215	78,072	55,000
44745	PRO SHOP REVENUE			31,871	50,000
48000	MISCELLANEOUS REVENUE	208,622	418	446	500
48100	REFUNDS		50		
49100	TRANSFERS IN	422,797	44,058	83,432	216,890
TOTAL ESTIMATED REVENUES		1,000,289	559,143	648,623	779,890
APPROPRIATIONS					
51100	SALARIES AND WAGES	102,334	221,458	157,222	185,270
51200	OVERTIME	2,378	1,626	520	490
51300	TEMPORARY AND SEASONAL	54,936	57,006	52,207	56,220
52100	SOCIAL SECURITY	14,085	16,059	15,511	18,520
52200	GROUP INSURANCE	33,443	38,114	40,874	46,240
52300	RETIREMENT	8,286	9,545	8,227	11,150
52500	UNEMPLOYMENT	(1,180)			
52600	WORKERS' COMPENSATION	1,029	1,595	(344)	2,000
52700	TRAINING AND TUITION	339	890	570	1,000
52710	EMPLOYEE RECRUITMENT/RETENTION	764	2,431	969	1,500
53200	PROFESSIONAL SERVICES	125		686	500
53400	COMPUTER SUPPORT/MAINT	5,608	8,432	4,962	10,000
53500	COMMISSION ON CARTS	9,240	12,258	19,122	12,000
53510	COMMISSION ON LIQUOR	18,575	32,806	35,983	20,000
53520	CONTRACT SERVICES	51,930	52,236	45,973	60,000
53530	COMMISSION ON GREEN FEES	5,924	7,422	14,027	8,000
53540	COMMISSION ON PASSES	3,578	5,012	15,300	15,000
54310	BUILDING MAINTENANCE	10,222	4,987	12,457	6,000
54320	EQUIPMENT MAINTENANCE	28,626	27,550	31,392	30,000
54330	VEHICLE MAINTENANCE	30	591	826	1,000
54350	GOLF CART/COURSE MAINT	18,969	11,777	15,176	14,000
54490	IRRIGATION MAINTENANCE	15,176	13,841	13,541	20,000
54510	BUILDING RENTAL/LEASE	1	1	1	
54520	EQUIPMENT RENTAL/PURCHASE	1,605	10,650	6,765	2,500
55200	INSURANCE	11,460	18,074	6,692	8,000
55400	ADVERTISING AND PROMOTION	2,839	4,266	3,332	5,000
55900	MISCELLANEOUS				500
55920	MISC FEES	13,666	16,410	45,859	15,000
56010	SUPPLIES	6,787	6,167	7,211	6,500
56020	OFFICE SUPPLIES	79	151	172	250
56040	POSTAGE AND FREIGHT	6			
56050	FUEL	12,358	23,001	12,689	25,000
56060	CHEMICALS	24,241	33,395	31,712	35,000
56070	FERTILIZER	10,730	8,463	11,339	10,000
56080	PLANTS SOD SEED FLOWERS	3,841	4,338	2,975	3,500
56110	PRO-SHOP SUPPLIES	2,745	3,942	3,917	3,500
56190	PERSONAL PROTECTIVE SUPP	130	86	34	500
56210	NATURAL GAS	1,168	3,223	3,232	4,000
56220	ELECTRICITY	19,849	33,979	13,001	34,000
56230	WATER AND SEWER	4,947	1,704	1,417	3,000
56240	TELEPHONE	1,476	1,808	2,525	3,000
56250	REFUSE	50	197	9	250
56650	MEMBERSHIP DUES	1,476	1,848	933	1,500
56690	SALES TAX REMITTANCE	25,540	34,711	36,460	30,000
57200	CAPITAL-LAND & BUILDINGS	165,758		179,656	
57300	CAPITAL-NEW CONSTRUCTION	9,784			
57510	CAPITAL-EQUIPMENT				70,000
57950	DEPRECIATION		186,162		
TOTAL APPROPRIATIONS		704,953	918,212	855,132	779,890
NET OF REVENUES/APPROPRIATIONS - 156 - QUAIL RUN GOLF		295,336	(359,069)	(206,509)	
ESTIMATED REVENUES - FUND 100		20,877,525	35,787,889	25,303,392	37,523,785
APPROPRIATIONS - FUND 100		18,401,505	20,284,401	28,224,853	36,554,050
NET OF REVENUES/APPROPRIATIONS - FUND 100		2,476,020	15,503,488	(2,921,461)	969,735
BEGINNING FUND BALANCE		47,541,753	9,925,223	68,177,731	65,256,270
FUND BALANCE ADJUSTMENTS		(40,092,555)	42,749,022		

Calculations as of 09/30/2023

ACCOUNT	DESCRIPTION	2020-21 ACTIVITY	2021-22 ACTIVITY	2022-23 ACTIVITY THRU 09/30/23	2023-24 FINANCE REVIEW BUDGET
	ENDING FUND BALANCE	9,925,218	68,177,733	65,256,270	66,226,005

Calculations as of 09/30/2023

ACCOUNT	DESCRIPTION	2020-21 ACTIVITY	2021-22 ACTIVITY	2022-23 ACTIVITY THRU 09/30/23	2023-24 FINANCE REVIEW BUDGET
Dept 160 - PLATTE CO LIBRARY SERVICE					
ESTIMATED REVENUES					
43910	COUNTY BOOKMOBILE CONT	145,761			
46100	INTEREST	679	472	2,007	
48000	MISCELLANEOUS REVENUE	539			
49210	LAND OR PROPERTY SALES		12,808		
TOTAL ESTIMATED REVENUES		146,979	13,280	2,007	
APPROPRIATIONS					
51100	SALARIES AND WAGES	37,490			
52100	SOCIAL SECURITY	3,110			
52200	GROUP INSURANCE	6,863			
52300	RETIREMENT	2,408			
52600	WORKERS' COMPENSATION	916			
52700	TRAINING AND TUITION	73			
54320	EQUIPMENT MAINTENANCE	540			
54330	VEHICLE MAINTENANCE	2,697			
55200	INSURANCE	564			
55900	MISCELLANEOUS	548			
56050	FUEL	1,213			
56240	TELEPHONE	373			
56410	BOOKS AND PUBLICATIONS	2,213			
57950	DEPRECIATION		122		
58100	TRANSFERS OUT	58,000			
TOTAL APPROPRIATIONS		117,008	122		
NET OF REVENUES/APPROPRIATIONS - 160 - PLATTE CO LIBF		29,971	13,158	2,007	
ESTIMATED REVENUES - FUND 160		146,979	13,280	2,007	
APPROPRIATIONS - FUND 160		117,008	122		
NET OF REVENUES/APPROPRIATIONS - FUND 160		29,971	13,158	2,007	
BEGINNING FUND BALANCE		54,989	79,258	93,161	95,168
FUND BALANCE ADJUSTMENTS		(5,702)	745		
ENDING FUND BALANCE		79,258	93,161	95,168	95,168

Calculations as of 09/30/2023

ACCOUNT	DESCRIPTION	2020-21 ACTIVITY	2021-22 ACTIVITY	2022-23 ACTIVITY THRU 09/30/23	2023-24 FINANCE REVIEW BUDGET
Dept 175 - ARP ACT FUNDS					
ESTIMATED REVENUES					
46100	INTEREST		13,250	90,369	
	TOTAL ESTIMATED REVENUES		13,250	90,369	
APPROPRIATIONS					
58100	TRANSFERS OUT			2,570,043	600,000
	TOTAL APPROPRIATIONS			2,570,043	600,000
NET OF REVENUES/APPROPRIATIONS - 175 - ARP ACT FUNDS			13,250	(2,479,674)	(600,000)
ESTIMATED REVENUES - FUND 175			13,250	90,369	
APPROPRIATIONS - FUND 175				2,570,043	600,000
NET OF REVENUES/APPROPRIATIONS - FUND 175			13,250	(2,479,674)	(600,000)
	BEGINNING FUND BALANCE			13,251	(2,466,423)
	ENDING FUND BALANCE		13,250	(2,466,423)	(3,066,423)

Calculations as of 09/30/2023

ACCOUNT	DESCRIPTION	2020-21 ACTIVITY	2021-22 ACTIVITY	2022-23 ACTIVITY THRU 09/30/23	2023-24 FINANCE REVIEW BUDGET
Dept 189 - PERPETUAL CARE					
ESTIMATED REVENUES					
46100	INTEREST	775	413	1,735	
TOTAL ESTIMATED REVENUES		775	413	1,735	
NET OF REVENUES/APPROPRIATIONS - 189 - PERPETUAL CARE		775	413	1,735	
ESTIMATED REVENUES - FUND 189					
APPROPRIATIONS - FUND 189					
NET OF REVENUES/APPROPRIATIONS - FUND 189		775	413	1,735	
	BEGINNING FUND BALANCE	78,822	79,597	80,011	81,746
	ENDING FUND BALANCE	79,597	80,010	81,746	81,746

ACCOUNT	DESCRIPTION	2020-21 ACTIVITY	2021-22 ACTIVITY	2022-23 ACTIVITY THRU 09/30/23	2023-24 FINANCE REVIEW BUDGET
Dept 200 - STREETS					
ESTIMATED REVENUES					
42136	OTHER PERMITS	25			
43102	FEDERAL GRANTS	2,775,211	3,209,298	51,576	
43103	CDBG GRANTS	43,816			
43540	MOTOR VEHICLE FUEL TAX	2,946,274	2,982,600	2,660,441	3,394,407
43550	MOTOR VEHICLE FEES	200,559	216,061	220,301	220,000
43560	NEBR FED FUNDS PURCHASE	462,666	476,738	601,174	598,720
43710	LOCAL GRANTS			50,000	
44150	FUEL	63,446	97,722	65,565	87,400
45330	CONCRETE CUTS			38	
45510	SPECIAL ASSESS PRINCIPAL	512,071	513,336	386,096	25,000
45515	SPECIAL ASSESS INTEREST	10,783	12,703	20,038	9,100
46100	INTEREST	13,797	23,503	48,050	60,000
48000	MISCELLANEOUS REVENUE	73,511	27,597	3,494	30,000
48100	REFUNDS	20,607	15,542	2,289	1,250
48200	MAINTENANCE REVENUE	19,639			500
49100	TRANSFERS IN	8,980,898	4,291,820	3,524,392	1,855,000
49210	LAND OR PROPERTY SALES	63,744	2,400	24,759	
TOTAL ESTIMATED REVENUES		16,187,047	11,869,320	7,658,213	6,281,377
APPROPRIATIONS					
51100	SALARIES AND WAGES	1,018,627	1,175,901	1,049,989	1,220,420
51200	OVERTIME	8,343	1,816	10,002	12,180
51300	TEMPORARY AND SEASONAL	6,745	5,712	3,822	3,660
52100	SOCIAL SECURITY	83,395	86,449	77,415	94,580
52200	GROUP INSURANCE	403,209	352,839	287,989	327,700
52300	RETIREMENT	67,542	71,714	53,072	73,960
52500	UNEMPLOYMENT				1,000
52600	WORKERS' COMPENSATION	27,054	28,664	7,075	12,500
52700	TRAINING AND TUITION	1,026	1,866	4,632	2,500
52710	EMPLOYEE RECRUITMENT/RETENTION	3,871	5,488	2,556	3,000
52800	UNIFORMS	15,496	14,131	10,137	13,500
53100	ENGINEERING SERVICES	17,850	241		
53200	PROFESSIONAL SERVICES	15,852	9,755	1,267	3,000
53400	COMPUTER SUPPORT/MAINT	13,095	20,568	21,744	18,000
54310	BUILDING MAINTENANCE	193,892	186,842	147,962	174,720
54320	EQUIPMENT MAINTENANCE	71,876	77,693	59,540	75,000
54330	VEHICLE MAINTENANCE	28,148	14,517	10,238	25,000
54450	STREET MAINTENANCE	86,231	88,984	43,357	70,000
54460	LAND MAINTENANCE	6,126	14,012	1,522	30,000
54520	EQUIPMENT RENTAL/PURCHASE	35,436		2,553	16,000
55200	INSURANCE	23,331	27,918	61,581	62,000
55210	CLAIMS AND SETTLEMENTS	44,895	6,580	1,000	3,000
55900	MISCELLANEOUS	9,237			500
55930	REFUNDS	151	108	31	
56010	SUPPLIES	127,276	100,612	65,485	120,000
56020	OFFICE SUPPLIES	433	2,065	449	1,250
56040	POSTAGE AND FREIGHT	2	27	96	100
56050	FUEL	129,992	171,069	124,145	140,000
56090	SMALL TOOLS	1,730	2,631	894	2,250
56120	TRAFFIC SIGNS	25,759	30,752	21,011	30,000
56130	SUPPLIES FOR RESALE	7,868			
56190	PERSONAL PROTECTIVE SUPP	2,098	2,475	1,054	3,000
56210	NATURAL GAS	7,269	13,778	10,170	12,000
56220	ELECTRICITY	390,737	399,129	297,412	395,000
56230	WATER AND SEWER	2,241	1,555	1,899	2,000
56240	TELEPHONE	2,850	2,343	1,984	2,500
56250	REFUSE	17,030	19,021	6,075	22,500
56650	MEMBERSHIP DUES	60	487		500
57200	CAPITAL-LAND & BUILDINGS	123,951		1,629,151	975,000
57300	CAPITAL-NEW CONSTRUCTION	6,845,496		5,497,871	4,263,123
57510	CAPITAL-EQUIPMENT			367,845	80,000
57520	CAPITAL-VEHICLES			51,923	50,000
57950	DEPRECIATION		2,653,934		
57990	LOSS ON DISPOSITION		41,339		
TOTAL APPROPRIATIONS		9,866,220	5,633,015	9,934,948	8,341,443
NET OF REVENUES/APPROPRIATIONS - 200 - STREETS		6,320,827	6,236,305	(2,276,735)	(2,060,066)

ACCOUNT	DESCRIPTION	2020-21 ACTIVITY	2021-22 ACTIVITY	2022-23 ACTIVITY THRU 09/30/23	2023-24 FINANCE REVIEW BUDGET
Dept 202 - MECHANICS SHOP					
ESTIMATED REVENUES					
48200	MAINTENANCE REVENUE		49,998	30,735	60,000
TOTAL ESTIMATED REVENUES			49,998	30,735	60,000
APPROPRIATIONS					
51100	SALARIES AND WAGES		54,896	56,687	65,750
52100	SOCIAL SECURITY		4,512	4,289	5,030
52200	GROUP INSURANCE		8,725	8,438	9,600
52300	RETIREMENT		3,585	2,896	3,950
52700	TRAINING AND TUITION			1,356	1,500
52800	UNIFORMS		819	1,414	2,000
53400	COMPUTER SUPPORT/MAINT		7,256	3,680	4,000
56010	SUPPLIES		4,317	1,887	2,500
56090	SMALL TOOLS		3,696	3,615	5,000
56130	SUPPLIES FOR RESALE		43,784	37,327	33,550
TOTAL APPROPRIATIONS			131,590	121,589	132,880
NET OF REVENUES/APPROPRIATIONS - 202 - MECHANICS SHOP			(81,592)	(90,854)	(72,880)
ESTIMATED REVENUES - FUND 200		16,187,047	11,919,318	7,688,948	6,341,377
APPROPRIATIONS - FUND 200		9,866,220	5,764,605	10,056,537	8,474,323
NET OF REVENUES/APPROPRIATIONS - FUND 200		6,320,827	6,154,713	(2,367,589)	(2,132,946)
BEGINNING FUND BALANCE		66,388,591	5,531,966	85,892,667	83,525,078
FUND BALANCE ADJUSTMENTS		(67,177,455)	74,205,986		
ENDING FUND BALANCE		5,531,963	85,892,665	83,525,078	81,392,132

Calculations as of 09/30/2023

ACCOUNT	DESCRIPTION	2020-21 ACTIVITY	2021-22 ACTIVITY	2022-23 ACTIVITY THRU 09/30/23	2023-24 FINANCE REVIEW BUDGET
Dept 205 - AIRPORT					
ESTIMATED REVENUES					
43102	FEDERAL GRANTS	234,859	32,000	16,619	351,000
44125	RECORDING FEES	25			
44150	FUEL	9,103	7,892	5,754	9,000
45310	BUILDING RENTALS	68,599	94,238	83,765	90,000
45315	AIRPORT FBO RENT	21,816	21,816	21,090	24,000
45325	LAND RENTALS	47,533	45,021	46,307	47,540
45327	AIRPORT LEASED LAND	12,346	13,219	14,089	14,090
46100	INTEREST	8,388	4,616	19,842	21,000
48000	MISCELLANEOUS REVENUE	13,000	1,331	7,588	
48100	REFUNDS	53			
49100	TRANSFERS IN	161,725	185,097	212,727	708,000
49210	LAND OR PROPERTY SALES			800	
TOTAL ESTIMATED REVENUES		577,447	405,230	428,581	1,264,630
APPROPRIATIONS					
51100	SALARIES AND WAGES	104,441	152,596	109,879	128,400
51200	OVERTIME	2,451	647	518	640
51300	TEMPORARY AND SEASONAL	6,183	4,191	363	450
52100	SOCIAL SECURITY	8,790	10,875	7,915	9,910
52200	GROUP INSURANCE	49,318	44,575	27,163	31,200
52300	RETIREMENT	7,068	8,710	4,742	7,750
52600	WORKERS' COMPENSATION	1,960	1,810	647	2,000
52700	TRAINING AND TUITION	1,196	1,733	450	2,000
52710	EMPLOYEE RECRUITMENT/RETENTION	244	2,637	284	500
53200	PROFESSIONAL SERVICES				500
53400	COMPUTER SUPPORT/MAINT			2,201	
53520	CONTRACT SERVICES	2,520	2,455	2,096	5,000
54310	BUILDING MAINTENANCE	3,477	3,992	600	4,000
54320	EQUIPMENT MAINTENANCE	14,864	11,001	7,382	14,000
54330	VEHICLE MAINTENANCE	9,531	4,507	1,502	5,540
54440	RUNWAY MAINTENANCE	38,477	2,625	88	25,000
54470	FSS BUILDING MAINTENANCE	1,002	1,962	383	2,000
54480	HANGAR MAINTENANCE	7,180	5,478	2,196	7,000
54520	EQUIPMENT RENTAL/PURCHASE		92	38	500
55200	INSURANCE	14,180	17,638	25,364	26,000
55210	CLAIMS AND SETTLEMENTS			7,061	
55400	ADVERTISING AND PROMOTION	450	604	249	2,000
55900	MISCELLANEOUS	459	396		100
55930	REFUNDS		100	516	
56010	SUPPLIES	5,552	4,862	1,463	8,000
56020	OFFICE SUPPLIES	295	776	208	480
56030	CLEANING SUPPLIES/SERVICE	5,788	6,543	3,701	7,000
56040	POSTAGE AND FREIGHT	9	9		120
56050	FUEL	5,918	6,467	2,864	8,590
56070	FERTILIZER	552	1,700	941	2,000
56090	SMALL TOOLS	539	109	272	3,500
56190	PERSONAL PROTECTIVE SUPP		117	289	1,000
56210	NATURAL GAS	974			
56220	ELECTRICITY	13,082	11,688	11,905	15,000
56230	WATER AND SEWER	359	301	265	1,000
56240	TELEPHONE	2,326	2,390	989	2,110
56250	REFUSE	213	61	66	500
56260	UTILITIES - FSS BUILDING	9,893	9,534	3,944	8,500
56650	MEMBERSHIP DUES			150	320
57200	CAPITAL-LAND & BUILDINGS	46,834		108,180	2,100,000
57300	CAPITAL-NEW CONSTRUCTION	6,097			
57510	CAPITAL-EQUIPMENT				158,000
57520	CAPITAL-VEHICLES				35,000
57950	DEPRECIATION	(1)	233,922		
TOTAL APPROPRIATIONS		372,221	557,103	336,874	2,625,610
NET OF REVENUES/APPROPRIATIONS - 205 - AIRPORT		205,226	(151,873)	91,707	(1,360,980)
ESTIMATED REVENUES - FUND 205		577,447	405,230	428,581	1,264,630
APPROPRIATIONS - FUND 205		372,221	557,103	336,874	2,625,610
NET OF REVENUES/APPROPRIATIONS - FUND 205		205,226	(151,873)	91,707	(1,360,980)
BEGINNING FUND BALANCE		6,887,398	7,092,625	6,736,921	6,828,628
FUND BALANCE ADJUSTMENTS			(203,832)		
ENDING FUND BALANCE		7,092,624	6,736,920	6,828,628	5,467,648

Calculations as of 09/30/2023

ACCOUNT	DESCRIPTION	2020-21 ACTIVITY	2021-22 ACTIVITY	2022-23 ACTIVITY THRU 09/30/23	2023-24 FINANCE REVIEW BUDGET
Dept 210 - SALES TAX					
ESTIMATED REVENUES					
41330	CITY SALES TAX FROM STATE	5,828,037	6,307,402	5,098,207	6,041,667
46100	INTEREST	88,884	51,554	186,425	200,000
49100	TRANSFERS IN	4,679			
	TOTAL ESTIMATED REVENUES	<u>5,921,600</u>	<u>6,358,956</u>	<u>5,284,632</u>	<u>6,241,667</u>
APPROPRIATIONS					
58100	TRANSFERS OUT	4,102,889	7,507,338	4,997,593	10,622,901
	TOTAL APPROPRIATIONS	<u>4,102,889</u>	<u>7,507,338</u>	<u>4,997,593</u>	<u>10,622,901</u>
NET OF REVENUES/APPROPRIATIONS - 210 - SALES TAX		<u>1,818,711</u>	<u>(1,148,382)</u>	<u>287,039</u>	<u>(4,381,234)</u>
ESTIMATED REVENUES - FUND 210		5,921,600	6,358,956	5,284,632	6,241,667
APPROPRIATIONS - FUND 210		4,102,889	7,507,338	4,997,593	10,622,901
NET OF REVENUES/APPROPRIATIONS - FUND 210		1,818,711	(1,148,382)	287,039	(4,381,234)
	BEGINNING FUND BALANCE	7,848,145	10,604,834	9,456,452	9,743,491
	FUND BALANCE ADJUSTMENTS	937,978			
	ENDING FUND BALANCE	10,604,834	9,456,452	9,743,491	5,362,257

ACCOUNT	DESCRIPTION	2020-21 ACTIVITY	2021-22 ACTIVITY	2022-23 ACTIVITY THRU 09/30/23	2023-24 FINANCE REVIEW BUDGET
Dept 211 - 1/2 CENT SALES TAX					
ESTIMATED REVENUES					
41330	CITY SALES TAX FROM STATE	2,631,810	2,868,550	2,344,313	2,783,333
46100	INTEREST	29,801	58,507	92,892	
49310	BOND PROCEEDS	9,430,000	8,177		
	TOTAL ESTIMATED REVENUES	12,091,611	2,935,234	2,437,205	2,783,333
APPROPRIATIONS					
52600	WORKERS' COMPENSATION	305			
57550	CAPITAL-CAPITAL IMPROVE	513,353			
58100	TRANSFERS OUT	2,479,183	12,200,005	3,382,305	
59010	PRINCIPAL				660,000
59020	INTEREST AND FISCAL FEES	606,578	617,214	584,037	552,140
	TOTAL APPROPRIATIONS	3,599,419	12,817,219	3,966,342	1,212,140
NET OF REVENUES/APPROPRIATIONS - 211 - 1/2 CENT SALES		8,492,192	(9,881,985)	(1,529,137)	1,571,193
ESTIMATED REVENUES - FUND 211		12,091,611	2,935,234	2,437,205	2,783,333
APPROPRIATIONS - FUND 211		3,599,419	12,817,219	3,966,342	1,212,140
NET OF REVENUES/APPROPRIATIONS - FUND 211		8,492,192	(9,881,985)	(1,529,137)	1,571,193
BEGINNING FUND BALANCE		(9,673,458)	14,145,578	(20,125,722)	(21,654,859)
FUND BALANCE ADJUSTMENTS		15,326,844	(24,389,315)		
ENDING FUND BALANCE		14,145,578	(20,125,722)	(21,654,859)	(20,083,666)

Calculations as of 09/30/2023

ACCOUNT	DESCRIPTION	2020-21 ACTIVITY	2021-22 ACTIVITY	2022-23 ACTIVITY THRU 09/30/23	2023-24 FINANCE REVIEW BUDGET
Dept 220 - E911					
ESTIMATED REVENUES					
41810	E911 TELEPHONE SURCHARGE	92,794	93,842	75,000	95,000
43410	STATE GRANTS			33,310	
43915	COUNTY REIMBURSEMENTS	1,291,768	1,427,480	1,125,077	2,252,441
46100	INTEREST	1,629	2,034	6,548	1,000
48000	MISCELLANEOUS REVENUE	285,765	38,654	233	12,620
TOTAL ESTIMATED REVENUES		1,671,956	1,562,010	1,240,168	2,361,061
APPROPRIATIONS					
51100	SALARIES AND WAGES	655,050	775,343	718,447	967,741
51200	OVERTIME	62,607	85,017	85,506	80,000
51300	TEMPORARY AND SEASONAL	1,431			
52100	SOCIAL SECURITY	65,149	70,440	64,023	85,313
52200	GROUP INSURANCE	223,577	198,938	115,379	321,760
52300	RETIREMENT	51,561	57,652	41,447	66,913
52600	WORKERS' COMPENSATION	489			560
52700	TRAINING AND TUITION	9,373	13,818	11,857	19,000
52710	EMPLOYEE RECRUITMENT/RETENTION	5,775	5,232	2,825	6,500
52800	UNIFORMS	501	460	405	1,250
53200	PROFESSIONAL SERVICES	86	940	724	9,312
53400	COMPUTER SUPPORT/MAINT	9,147	17,094	7,069	17,700
54310	BUILDING MAINTENANCE	8	468	3	6,500
54320	EQUIPMENT MAINTENANCE	703	2,414	1,078	7,254
54380	MAINTENANCE AGREEMENTS	91,946	101,377	42,026	142,585
55200	INSURANCE	2,640	2,808	3,186	3,000
55900	MISCELLANEOUS	699	2,312	1,425	2,500
55950	COVID-19 EXPENSES	18			
56010	SUPPLIES	2,763	2,348	2,377	7,000
56020	OFFICE SUPPLIES	1,188	3,480	5,006	3,000
56030	CLEANING SUPPLIES/SERVICE	9,884	8,845	4,425	5,500
56040	POSTAGE AND FREIGHT	89	101	155	500
56050	FUEL			172	1,000
56190	PERSONAL PROTECTIVE SUPP	68			1,000
56220	ELECTRICITY	6,758	6,672	5,137	8,600
56230	WATER AND SEWER	668	628	557	700
56240	TELEPHONE	26,729	29,757	33,303	42,043
56250	REFUSE	510	510	404	510
56650	MEMBERSHIP DUES	409	321	195	1,205
56690	SALES TAX REMITTANCE	10	19	16	20
57510	CAPITAL-EQUIPMENT	(92,928)		311,015	837,500
57950	DEPRECIATION	10,707	281,691		
TOTAL APPROPRIATIONS		1,147,615	1,668,685	1,458,162	2,646,466
NET OF REVENUES/APPROPRIATIONS - 220 - E911		524,341	(106,675)	(217,994)	(285,405)
ESTIMATED REVENUES - FUND 220		1,671,956	1,562,010	1,240,168	2,361,061
APPROPRIATIONS - FUND 220		1,147,615	1,668,685	1,458,162	2,646,466
NET OF REVENUES/APPROPRIATIONS - FUND 220		524,341	(106,675)	(217,994)	(285,405)
BEGINNING FUND BALANCE		1,829,412	366,204	1,901,794	1,683,800
FUND BALANCE ADJUSTMENTS		(1,987,552)	1,642,264		
ENDING FUND BALANCE		366,201	1,901,793	1,683,800	1,398,395

Calculations as of 09/30/2023

ACCOUNT	DESCRIPTION	2020-21 ACTIVITY	2021-22 ACTIVITY	2022-23 ACTIVITY THRU 09/30/23	2023-24 FINANCE REVIEW BUDGET
Dept 221 - WIRELESS E911					
ESTIMATED REVENUES					
43410	STATE GRANTS	100,309	65,161	79,147	69,558
43915	COUNTY REIMBURSEMENTS	232,851			
46100	INTEREST	471	1,044	4,336	
TOTAL ESTIMATED REVENUES		333,631	66,205	83,483	69,558
APPROPRIATIONS					
51100	SALARIES AND WAGES	48,012	18,227	57,776	67,190
51200	OVERTIME	7,984			
52100	SOCIAL SECURITY			193	
52200	GROUP INSURANCE			350	
52300	RETIREMENT			155	
52700	TRAINING AND TUITION	212			
53200	PROFESSIONAL SERVICES	427	79		
54380	MAINTENANCE AGREEMENTS	16,740	31,790		
56240	TELEPHONE	9,926	6,629		
57510	CAPITAL-EQUIPMENT		29,932		
TOTAL APPROPRIATIONS		83,301	86,657	58,474	67,190
NET OF REVENUES/APPROPRIATIONS - 221 - WIRELESS E911		250,330	(20,452)	25,009	2,368
ESTIMATED REVENUES - FUND 221		333,631	66,205	83,483	69,558
APPROPRIATIONS - FUND 221		83,301	86,657	58,474	67,190
NET OF REVENUES/APPROPRIATIONS - FUND 221		250,330	(20,452)	25,009	2,368
BEGINNING FUND BALANCE		(44,986)	205,344	184,892	209,901
ENDING FUND BALANCE		205,344	184,892	209,901	212,269

Calculations as of 09/30/2023

ACCOUNT	DESCRIPTION	2020-21 ACTIVITY	2021-22 ACTIVITY	2022-23 ACTIVITY THRU 09/30/23	2023-24 FINANCE REVIEW BUDGET
Dept 225 - EC-911 EQUIPMENT SHARING					
ESTIMATED REVENUES					
43410	STATE GRANTS	18,648	15,540	1,554	24,613
TOTAL ESTIMATED REVENUES		18,648	15,540	1,554	24,613
APPROPRIATIONS					
54320	EQUIPMENT MAINTENANCE	109,591			
54380	MAINTENANCE AGREEMENTS	5,000	5,000		5,965
56240	TELEPHONE	18,648	18,648	14,819	18,648
57510	CAPITAL-EQUIPMENT			258,770	
57950	DEPRECIATION	(10,706)	28,570		
TOTAL APPROPRIATIONS		122,533	52,218	273,589	24,613
NET OF REVENUES/APPROPRIATIONS - 225 - EC-911 EQUIPME		(103,885)	(36,678)	(272,035)	
ESTIMATED REVENUES - FUND 225		18,648	15,540	1,554	24,613
APPROPRIATIONS - FUND 225		122,533	52,218	273,589	24,613
NET OF REVENUES/APPROPRIATIONS - FUND 225		(103,885)	(36,678)	(272,035)	
BEGINNING FUND BALANCE		199,240	(108,317)	11,029	(261,006)
FUND BALANCE ADJUSTMENTS		(203,672)	156,024		
ENDING FUND BALANCE		(108,317)	11,029	(261,006)	(261,006)

Calculations as of 09/30/2023

ACCOUNT	DESCRIPTION	2020-21 ACTIVITY	2021-22 ACTIVITY	2022-23 ACTIVITY THRU 09/30/23	2023-24 FINANCE REVIEW BUDGET
Dept 240 - HOUSING REHAB & LOANS					
ESTIMATED REVENUES					
43410	STATE GRANTS				500,000
44126	HOUSING FEES	1,434	1,434	956	
45512	LOAN REPAYMENTS	30,000		1,035	30,000
46100	INTEREST	985	319	1,503	1,500
	TOTAL ESTIMATED REVENUES	32,419	1,753	3,494	531,500
APPROPRIATIONS					
56780	HOUSING LOANS & ADMIN	518	549	3,886	580,000
	TOTAL APPROPRIATIONS	518	549	3,886	580,000
NET OF REVENUES/APPROPRIATIONS - 240 - HOUSING REHAB		31,901	1,204	(392)	(48,500)

Calculations as of 09/30/2023

ACCOUNT	DESCRIPTION	2020-21 ACTIVITY	2021-22 ACTIVITY	2022-23 ACTIVITY THRU 09/30/23	2023-24 FINANCE REVIEW BUDGET
Dept 243 - CDBG REVOLVING REHAB LOAN					
ESTIMATED REVENUES					
45512	LOAN REPAYMENTS	10		41,295	1,730
	TOTAL ESTIMATED REVENUES	10		41,295	1,730
APPROPRIATIONS					
56780	HOUSING LOANS & ADMIN	4,956	493	4,475	1,730
	TOTAL APPROPRIATIONS	4,956	493	4,475	1,730
NET OF REVENUES/APPROPRIATIONS - 243 - CDBG REVOLVING		(4,946)	(493)	36,820	

Calculations as of 09/30/2023

ACCOUNT	DESCRIPTION	2020-21 ACTIVITY	2021-22 ACTIVITY	2022-23 ACTIVITY THRU 09/30/23	2023-24 FINANCE REVIEW BUDGET
Dept 244 - CDBG DPA LOANS (NENEDD)					
ESTIMATED REVENUES					
45512	LOAN REPAYMENTS				2,500
	TOTAL ESTIMATED REVENUES				2,500
APPROPRIATIONS					
56780	HOUSING LOANS & ADMIN	503	788	564	2,500
	TOTAL APPROPRIATIONS	503	788	564	2,500
NET OF REVENUES/APPROPRIATIONS - 244 - CDBG DPA LOANS		(503)	(788)	(564)	

Calculations as of 09/30/2023

ACCOUNT	DESCRIPTION	2020-21 ACTIVITY	2021-22 ACTIVITY	2022-23 ACTIVITY THRU 09/30/23	2023-24 FINANCE REVIEW BUDGET
Dept 245 - CDBG GRANTS					
ESTIMATED REVENUES					
43103	CDBG GRANTS	167,133	114,895	54,475	750,000
48000	MISCELLANEOUS REVENUE	32,520			
	TOTAL ESTIMATED REVENUES	199,653	114,895	54,475	750,000
APPROPRIATIONS					
56780	HOUSING LOANS & ADMIN	216,843	50,413	70,960	750,000
	TOTAL APPROPRIATIONS	216,843	50,413	70,960	750,000
NET OF REVENUES/APPROPRIATIONS - 245 - CDBG GRANTS		(17,190)	64,482	(16,485)	

Calculations as of 09/30/2023

ACCOUNT	DESCRIPTION	2020-21 ACTIVITY	2021-22 ACTIVITY	2022-23 ACTIVITY THRU 09/30/23	2023-24 FINANCE REVIEW BUDGET
Dept 246 - PACE PROGRAM					
ESTIMATED REVENUES					
43104	PACE PROJECT FEES	250	500	500	500
	TOTAL ESTIMATED REVENUES	250	500	500	500
NET OF REVENUES/APPROPRIATIONS - 246 - PACE PROGRAM					
		250	500	500	500
ESTIMATED REVENUES - FUND 240					
		232,332	117,148	99,764	1,286,230
APPROPRIATIONS - FUND 240					
		222,820	52,243	79,885	1,334,230
NET OF REVENUES/APPROPRIATIONS - FUND 240					
		9,512	64,905	19,879	(48,000)
	BEGINNING FUND BALANCE	57,670	67,181	663,792	683,671
	FUND BALANCE ADJUSTMENTS		531,706		
	ENDING FUND BALANCE	67,182	663,792	683,671	635,671

ACCOUNT	DESCRIPTION	2020-21 ACTIVITY	2021-22 ACTIVITY	2022-23 ACTIVITY THRU 09/30/23	2023-24 FINANCE REVIEW BUDGET
Dept 250 - ECONOMIC DEVL REUSE					
ESTIMATED REVENUES					
43103	CDBG GRANTS	1,379	200,000		
TOTAL ESTIMATED REVENUES		1,379	200,000		
APPROPRIATIONS					
56720	REUSE LOANS/GRANTS		200,000		
56750	ECON DEVL LOAN & ADMIN	669			
TOTAL APPROPRIATIONS		669	200,000		
NET OF REVENUES/APPROPRIATIONS - 250 - ECONOMIC DEVL		710			
ESTIMATED REVENUES - FUND 250		1,379	200,000		
APPROPRIATIONS - FUND 250		669	200,000		
NET OF REVENUES/APPROPRIATIONS - FUND 250		710			
BEGINNING FUND BALANCE		(710)			
ENDING FUND BALANCE					

Calculations as of 09/30/2023

ACCOUNT	DESCRIPTION	2020-21 ACTIVITY	2021-22 ACTIVITY	2022-23 ACTIVITY THRU 09/30/23	2023-24 FINANCE REVIEW BUDGET
Dept 260 - PROGRESS AND JOBS GROWTH					
ESTIMATED REVENUES					
41330	CITY SALES TAX FROM STATE	434,948	434,820	425,000	425,000
45512	LOAN REPAYMENTS	68,329		89,730	
46100	INTEREST	20,025	11,254	39,622	44,500
48000	MISCELLANEOUS REVENUE			30,000	
TOTAL ESTIMATED REVENUES		523,302	446,074	584,352	469,500
APPROPRIATIONS					
56760	ECONOMIC DEVELOPMENT PLAN	856,000	85,000	600,000	
59999	BAD DEBT EXPENSE	90,075			
TOTAL APPROPRIATIONS		946,075	85,000	600,000	
NET OF REVENUES/APPROPRIATIONS - 260 - PROGRESS AND JOBS GROWTH		(422,773)	361,074	(15,648)	469,500
ESTIMATED REVENUES - FUND 260		523,302	446,074	584,352	469,500
APPROPRIATIONS - FUND 260		946,075	85,000	600,000	
NET OF REVENUES/APPROPRIATIONS - FUND 260		(422,773)	361,074	(15,648)	469,500
BEGINNING FUND BALANCE		1,583,482	1,447,544	2,625,446	2,609,798
FUND BALANCE ADJUSTMENTS		286,834	816,828		
ENDING FUND BALANCE		1,447,543	2,625,446	2,609,798	3,079,298

Calculations as of 09/30/2023

ACCOUNT	DESCRIPTION	2020-21 ACTIVITY	2021-22 ACTIVITY	2022-23 ACTIVITY THRU 09/30/23	2023-24 FINANCE REVIEW BUDGET
Dept 270 - KENO					
ESTIMATED REVENUES					
41830	KENO	601,090	714,112	758,809	765,000
46100	INTEREST	8,100	5,462	14,385	20,000
TOTAL ESTIMATED REVENUES		609,190	719,574	773,194	785,000
APPROPRIATIONS					
55900	MISCELLANEOUS		100		
58100	TRANSFERS OUT	594,410	580,000	675,825	837,740
TOTAL APPROPRIATIONS		594,410	580,100	675,825	837,740
NET OF REVENUES/APPROPRIATIONS - 270 - KENO		14,780	139,474	97,369	(52,740)
ESTIMATED REVENUES - FUND 270		609,190	719,574	773,194	785,000
APPROPRIATIONS - FUND 270		594,410	580,100	675,825	837,740
NET OF REVENUES/APPROPRIATIONS - FUND 270		14,780	139,474	97,369	(52,740)
BEGINNING FUND BALANCE		798,539	813,319	952,793	1,050,162
ENDING FUND BALANCE		813,319	952,793	1,050,162	997,422

Calculations as of 09/30/2023

ACCOUNT	DESCRIPTION	2020-21 ACTIVITY	2021-22 ACTIVITY	2022-23 ACTIVITY THRU 09/30/23	2023-24 FINANCE REVIEW BUDGET
Dept 417 - TAXES/INTEREST					
ESTIMATED REVENUES					
41100	PROPERTY TAX	502,338	497,291	362,342	501,340
43555	PRO-RATE MOTOR VEHICLE	1,420	1,452	1,112	1,500
43900	IN-LIEU-TAX	23,179	21,828	23,344	23,350
46100	INTEREST	5,763	41,182	32,234	35,000
TOTAL ESTIMATED REVENUES		532,700	561,753	419,032	561,190
APPROPRIATIONS					
58100	TRANSFERS OUT	545,949	500,652	501,336	497,353
TOTAL APPROPRIATIONS		545,949	500,652	501,336	497,353
NET OF REVENUES/APPROPRIATIONS - 417 - TAXES/INTEREST		(13,249)	61,101	(82,304)	63,837

Calculations as of 09/30/2023

ACCOUNT	DESCRIPTION	2020-21 ACTIVITY	2021-22 ACTIVITY	2022-23 ACTIVITY THRU 09/30/23	2023-24 FINANCE REVIEW BUDGET
Dept 451 - FLOOD CONTROL BONDS					
ESTIMATED REVENUES					
49100	TRANSFERS IN	495,943	500,652	501,336	497,353
	TOTAL ESTIMATED REVENUES	<u>495,943</u>	<u>500,652</u>	<u>501,336</u>	<u>497,353</u>
APPROPRIATIONS					
55900	MISCELLANEOUS	18,783			
59010	PRINCIPAL				495,000
59020	INTEREST AND FISCAL FEES	7,012	10,652	6,736	2,353
	TOTAL APPROPRIATIONS	<u>25,795</u>	<u>10,652</u>	<u>6,736</u>	<u>497,353</u>
NET OF REVENUES/APPROPRIATIONS - 451 - FLOOD CONTROL		470,148	490,000	494,600	

Calculations as of 09/30/2023

ACCOUNT	DESCRIPTION	2020-21 ACTIVITY	2021-22 ACTIVITY	2022-23 ACTIVITY THRU 09/30/23	2023-24 FINANCE REVIEW BUDGET
Dept 453 - 2004 VPB/2009 GO REFUND					
ESTIMATED REVENUES					
45510	SPECIAL ASSESS PRINCIPAL	4,737	(354)		
45515	SPECIAL ASSESS INTEREST	5,024			
	TOTAL ESTIMATED REVENUES	9,761	(354)		
NET OF REVENUES/APPROPRIATIONS - 453 - 2004 VPB/2009		9,761	(354)		

Calculations as of 09/30/2023

ACCOUNT	DESCRIPTION	2020-21 ACTIVITY	2021-22 ACTIVITY	2022-23 ACTIVITY THRU 09/30/23	2023-24 FINANCE REVIEW BUDGET
Dept 455 - 2008 VAR PURP BONDS					
ESTIMATED REVENUES					
45510	SPECIAL ASSESS PRINCIPAL	534	354		
45515	SPECIAL ASSESS INTEREST	64	19		
	TOTAL ESTIMATED REVENUES	598	373		
NET OF REVENUES/APPROPRIATIONS - 455 - 2008 VAR PURP		598	373		

Calculations as of 09/30/2023

ACCOUNT	DESCRIPTION	2020-21 ACTIVITY	2021-22 ACTIVITY	2022-23 ACTIVITY THRU 09/30/23	2023-24 FINANCE REVIEW BUDGET
Dept 456 - 2011 VAR PURP BONDS					
ESTIMATED REVENUES					
45510	SPECIAL ASSESS PRINCIPAL	19,016	734	6,096	
45515	SPECIAL ASSESS INTEREST	10,905	787	475	
49100	TRANSFERS IN	50,007			
	TOTAL ESTIMATED REVENUES	<u>79,928</u>	<u>1,521</u>	<u>6,571</u>	
APPROPRIATIONS					
59020	INTEREST AND FISCAL FEES	1,914	1,294		
	TOTAL APPROPRIATIONS	<u>1,914</u>	<u>1,294</u>		
NET OF REVENUES/APPROPRIATIONS - 456 - 2011 VAR PURP		<u>78,014</u>	<u>227</u>	<u>6,571</u>	

Calculations as of 09/30/2023

ACCOUNT	DESCRIPTION	2020-21 ACTIVITY	2021-22 ACTIVITY	2022-23 ACTIVITY THRU 09/30/23	2023-24 FINANCE REVIEW BUDGET
Dept 459 - 2021 COPS - CITY HALL					
ESTIMATED REVENUES					
46100	INTEREST			53,052	
49310	BOND PROCEEDS	9,455	37,819		
	TOTAL ESTIMATED REVENUES	<u>9,455</u>	<u>37,819</u>	<u>53,052</u>	
APPROPRIATIONS					
58100	TRANSFERS OUT		4,413,862	873,507	
59010	PRINCIPAL				365,000
59020	INTEREST AND FISCAL FEES	103,623	205,985	206,635	186,750
	TOTAL APPROPRIATIONS	<u>103,623</u>	<u>4,619,847</u>	<u>1,080,142</u>	<u>551,750</u>
NET OF REVENUES/APPROPRIATIONS - 459 - 2021 COPS - CI		(94,168)	(4,582,028)	(1,027,090)	(551,750)

Calculations as of 09/30/2023

ACCOUNT	DESCRIPTION	2020-21 ACTIVITY	2021-22 ACTIVITY	2022-23 ACTIVITY THRU 09/30/23	2023-24 FINANCE REVIEW BUDGET
Dept 460 - GENERAL OBLIGATION HIGHWAY ALLOC BONDS					
ESTIMATED REVENUES					
49100	TRANSFERS IN				60,000
49310	BOND PROCEEDS	13,211,794	33,597		
	TOTAL ESTIMATED REVENUES	13,211,794	33,597		60,000
APPROPRIATIONS					
58100	TRANSFERS OUT	6,600,974			
59010	PRINCIPAL				20,000
59020	INTEREST AND FISCAL FEES	82,639	113,728	185,650	185,350
	TOTAL APPROPRIATIONS	6,683,613	113,728	185,650	205,350
NET OF REVENUES/APPROPRIATIONS - 460 - GENERAL OBLIG		6,528,181	(80,131)	(185,650)	(145,350)
ESTIMATED REVENUES - FUND 400		14,340,179	1,135,361	979,991	1,118,543
APPROPRIATIONS - FUND 400		7,360,894	5,246,173	1,773,864	1,751,806
NET OF REVENUES/APPROPRIATIONS - FUND 400		6,979,285	(4,110,812)	(793,873)	(633,263)
	BEGINNING FUND BALANCE	(1,240,477)	7,884,628	(11,516,514)	(12,310,387)
	FUND BALANCE ADJUSTMENTS	2,145,821	(15,290,332)		
	ENDING FUND BALANCE	7,884,629	(11,516,516)	(12,310,387)	(12,943,650)

Calculations as of 09/30/2023

ACCOUNT	DESCRIPTION	2020-21 ACTIVITY	2021-22 ACTIVITY	2022-23 ACTIVITY THRU 09/30/23	2023-24 FINANCE REVIEW BUDGET
Dept 478 - EKEA LLC TIF					
ESTIMATED REVENUES					
41100	PROPERTY TAX			2,255	2,260
	TOTAL ESTIMATED REVENUES			2,255	2,260
APPROPRIATIONS					
59010	PRINCIPAL			2,255	2,260
	TOTAL APPROPRIATIONS			2,255	2,260
NET OF REVENUES/APPROPRIATIONS - 478 - EKEA LLC TIF					

Calculations as of 09/30/2023

ACCOUNT	DESCRIPTION	2020-21 ACTIVITY	2021-22 ACTIVITY	2022-23 ACTIVITY THRU 09/30/23	2023-24 FINANCE REVIEW BUDGET
Dept 479 - ACE OVERSIZED STORAGE TIF					
ESTIMATED REVENUES					
41100	PROPERTY TAX			567	570
	TOTAL ESTIMATED REVENUES			567	570
APPROPRIATIONS					
59010	PRINCIPAL			567	570
	TOTAL APPROPRIATIONS			567	570
NET OF REVENUES/APPROPRIATIONS - 479 - ACE OVERSIZED					

ACCOUNT	DESCRIPTION	2020-21 ACTIVITY	2021-22 ACTIVITY	2022-23 ACTIVITY THRU 09/30/23	2023-24 FINANCE REVIEW BUDGET
Dept 480 - VILLAGE ADD SHOPPING CNTR					
APPROPRIATIONS					
59998	TIF PAYMENTS TO REMIT	95,283			
	TOTAL APPROPRIATIONS	95,283			
NET OF REVENUES/APPROPRIATIONS - 480 - VILLAGE ADD SH		(95,283)			

ACCOUNT	DESCRIPTION	2020-21 ACTIVITY	2021-22 ACTIVITY	2022-23 ACTIVITY THRU 09/30/23	2023-24 FINANCE REVIEW BUDGET
Dept 482 - SLUMBERLAND					
ESTIMATED REVENUES					
41100	PROPERTY TAX	11,790	25,117	21,977	25,000
TOTAL ESTIMATED REVENUES		11,790	25,117	21,977	25,000
APPROPRIATIONS					
59010	PRINCIPAL	14,085	14,199	27,060	25,000
TOTAL APPROPRIATIONS		14,085	14,199	27,060	25,000
NET OF REVENUES/APPROPRIATIONS - 482 - SLUMBERLAND		(2,295)	10,918	(5,083)	

Calculations as of 09/30/2023

ACCOUNT	DESCRIPTION	2020-21 ACTIVITY	2021-22 ACTIVITY	2022-23 ACTIVITY THRU 09/30/23	2023-24 FINANCE REVIEW BUDGET
Dept 483 - RAMADA					
ESTIMATED REVENUES					
41100	PROPERTY TAX	87,410	58,585	31,013	58,000
TOTAL ESTIMATED REVENUES		87,410	58,585	31,013	58,000
APPROPRIATIONS					
59010	PRINCIPAL	46,502	75,748	31,013	58,000
59020	INTEREST AND FISCAL FEES	12,696	11,048		
TOTAL APPROPRIATIONS		59,198	86,796	31,013	58,000
NET OF REVENUES/APPROPRIATIONS - 483 - RAMADA		28,212	(28,211)		

ACCOUNT	DESCRIPTION	2020-21 ACTIVITY	2021-22 ACTIVITY	2022-23 ACTIVITY THRU 09/30/23	2023-24 FINANCE REVIEW BUDGET
Dept 484 - HOBBY LOBBY					
ESTIMATED REVENUES					
41100	PROPERTY TAX	31,175	30,659	16,230	32,000
TOTAL ESTIMATED REVENUES		31,175	30,659	16,230	32,000
APPROPRIATIONS					
53200	PROFESSIONAL SERVICES			16,230	
59010	PRINCIPAL	23,557	24,734		22,380
59020	INTEREST AND FISCAL FEES	7,423	6,226	14,463	9,620
TOTAL APPROPRIATIONS		30,980	30,960	30,693	32,000
NET OF REVENUES/APPROPRIATIONS - 484 - HOBBY LOBBY		195	(301)	(14,463)	

Calculations as of 09/30/2023

ACCOUNT	DESCRIPTION	2020-21 ACTIVITY	2021-22 ACTIVITY	2022-23 ACTIVITY THRU 09/30/23	2023-24 FINANCE REVIEW BUDGET
Dept 485 - WHO DEVEL - APARTMENTS					
ESTIMATED REVENUES					
41100	PROPERTY TAX	8,316	19,501	10,323	20,000
TOTAL ESTIMATED REVENUES		8,316	19,501	10,323	20,000
APPROPRIATIONS					
59010	PRINCIPAL			10,323	
59020	INTEREST AND FISCAL FEES	4,377	14,240	9,199	20,000
TOTAL APPROPRIATIONS		4,377	14,240	19,522	20,000
NET OF REVENUES/APPROPRIATIONS - 485 - WHO DEVEL - AF		3,939	5,261	(9,199)	

Calculations as of 09/30/2023

ACCOUNT	DESCRIPTION	2020-21 ACTIVITY	2021-22 ACTIVITY	2022-23 ACTIVITY THRU 09/30/23	2023-24 FINANCE REVIEW BUDGET
Dept 486 - WHO DEVELOPMENT - HOTEL					
ESTIMATED REVENUES					
41100	PROPERTY TAX	10,749	13,311	7,017	14,000
TOTAL ESTIMATED REVENUES		10,749	13,311	7,017	14,000
APPROPRIATIONS					
59010	PRINCIPAL	1,158	10,352	7,017	7,000
59020	INTEREST AND FISCAL FEES	4,500	1,771	6,279	7,000
TOTAL APPROPRIATIONS		5,658	12,123	13,296	14,000
NET OF REVENUES/APPROPRIATIONS - 486 - WHO DEVELOPMEN		5,091	1,188	(6,279)	

Calculations as of 09/30/2023

ACCOUNT	DESCRIPTION	2020-21 ACTIVITY	2021-22 ACTIVITY	2022-23 ACTIVITY THRU 09/30/23	2023-24 FINANCE REVIEW BUDGET
Dept 487 - QUANTUM COLUMBUS, LLC					
ESTIMATED REVENUES					
41100	PROPERTY TAX	42,606	99,918	52,894	52,900
	TOTAL ESTIMATED REVENUES	42,606	99,918	52,894	52,900
APPROPRIATIONS					
59010	PRINCIPAL			52,894	52,900
59020	INTEREST AND FISCAL FEES	22,429	72,960	47,134	
	TOTAL APPROPRIATIONS	22,429	72,960	100,028	52,900
NET OF REVENUES/APPROPRIATIONS - 487 - QUANTUM COLUME		20,177	26,958	(47,134)	

Calculations as of 09/30/2023

ACCOUNT	DESCRIPTION	2020-21 ACTIVITY	2021-22 ACTIVITY	2022-23 ACTIVITY THRU 09/30/23	2023-24 FINANCE REVIEW BUDGET
Dept 488 - COLUMBUS LODGING, LLC					
ESTIMATED REVENUES					
41100	PROPERTY TAX	41,659	51,590	27,196	54,000
TOTAL ESTIMATED REVENUES		41,659	51,590	27,196	54,000
APPROPRIATIONS					
59010	PRINCIPAL	4,493	40,120	27,196	27,000
59020	INTEREST AND FISCAL FEES	17,438	6,861	24,337	27,000
TOTAL APPROPRIATIONS		21,931	46,981	51,533	54,000
NET OF REVENUES/APPROPRIATIONS - 488 - COLUMBUS LODGI		19,728	4,609	(24,337)	

Calculations as of 09/30/2023

ACCOUNT	DESCRIPTION	2020-21 ACTIVITY	2021-22 ACTIVITY	2022-23 ACTIVITY THRU 09/30/23	2023-24 FINANCE REVIEW BUDGET
Dept 489 - COLUMBUS RETAIL, LLC					
ESTIMATED REVENUES					
41100	PROPERTY TAX	33,065	58,857	50,172	50,180
TOTAL ESTIMATED REVENUES		33,065	58,857	50,172	50,180
APPROPRIATIONS					
59010	PRINCIPAL	10,875	20,799	35,079	35,080
59020	INTEREST AND FISCAL FEES	13,285	29,485	36,640	15,100
TOTAL APPROPRIATIONS		24,160	50,284	71,719	50,180
NET OF REVENUES/APPROPRIATIONS - 489 - COLUMBUS RETAI		8,905	8,573	(21,547)	

Calculations as of 09/30/2023

ACCOUNT	DESCRIPTION	2020-21 ACTIVITY	2021-22 ACTIVITY	2022-23 ACTIVITY THRU 09/30/23	2023-24 FINANCE REVIEW BUDGET
Dept 490 - FRONTIER REDEVELOPMENT TIF BOND					
ESTIMATED REVENUES					
41100	PROPERTY TAX	21,904	39,795	56,320	56,320
TOTAL ESTIMATED REVENUES		21,904	39,795	56,320	56,320
APPROPRIATIONS					
59010	PRINCIPAL	1,804	8,395	61,072	56,320
59020	INTEREST AND FISCAL FEES	10,269	20,419		
TOTAL APPROPRIATIONS		12,073	28,814	61,072	56,320
NET OF REVENUES/APPROPRIATIONS - 490 - FRONTIER REDEV		9,831	10,981	(4,752)	

Calculations as of 09/30/2023

ACCOUNT	DESCRIPTION	2020-21 ACTIVITY	2021-22 ACTIVITY	2022-23 ACTIVITY THRU 09/30/23	2023-24 FINANCE REVIEW BUDGET
Dept 491 - WEST ELKS REDEVELOPMENT TIF BOND					
ESTIMATED REVENUES					
41100	PROPERTY TAX	10,106	9,939	14,492	14,500
TOTAL ESTIMATED REVENUES		10,106	9,939	14,492	14,500
APPROPRIATIONS					
59010	PRINCIPAL	5,515	5,510	14,492	14,500
59020	INTEREST AND FISCAL FEES	4,592	4,429		
TOTAL APPROPRIATIONS		10,107	9,939	14,492	14,500
NET OF REVENUES/APPROPRIATIONS - 491 - WEST ELKS REDE			(1)		

ACCOUNT	DESCRIPTION	2020-21 ACTIVITY	2021-22 ACTIVITY	2022-23 ACTIVITY THRU 09/30/23	2023-24 FINANCE REVIEW BUDGET
Dept 492 - SEQUOIA REDEVELOPMENT TIF BOND					
ESTIMATED REVENUES					
41100	PROPERTY TAX	2,596	2,553	2,560	2,560
	TOTAL ESTIMATED REVENUES	2,596	2,553	2,560	2,560
APPROPRIATIONS					
59010	PRINCIPAL	2,596	2,553	2,560	2,560
	TOTAL APPROPRIATIONS	2,596	2,553	2,560	2,560
NET OF REVENUES/APPROPRIATIONS - 492 - SEQUOIA REDEVE					

Calculations as of 09/30/2023

ACCOUNT	DESCRIPTION	2020-21 ACTIVITY	2021-22 ACTIVITY	2022-23 ACTIVITY THRU 09/30/23	2023-24 FINANCE REVIEW BUDGET
Dept 493 - FARM VIEW REDEVELOPMENT TIF BOND					
ESTIMATED REVENUES					
41100	PROPERTY TAX	6,207	95,387	118,368	118,370
TOTAL ESTIMATED REVENUES		6,207	95,387	118,368	118,370
APPROPRIATIONS					
59010	PRINCIPAL			148,281	
59020	INTEREST AND FISCAL FEES	4,704	60,895		118,370
TOTAL APPROPRIATIONS		4,704	60,895	148,281	118,370
NET OF REVENUES/APPROPRIATIONS - 493 - FARM VIEW REDE		1,503	34,492	(29,913)	

Calculations as of 09/30/2023

ACCOUNT	DESCRIPTION	2020-21 ACTIVITY	2021-22 ACTIVITY	2022-23 ACTIVITY THRU 09/30/23	2023-24 FINANCE REVIEW BUDGET
Dept 494 - FREDDY'S					
ESTIMATED REVENUES					
41100	PROPERTY TAX		17,544	9,288	9,290
	TOTAL ESTIMATED REVENUES		17,544	9,288	9,290
APPROPRIATIONS					
59020	INTEREST AND FISCAL FEES		9,268	17,564	9,290
	TOTAL APPROPRIATIONS		9,268	17,564	9,290
NET OF REVENUES/APPROPRIATIONS - 494 - FREDDY'S			8,276	(8,276)	

Calculations as of 09/30/2023

ACCOUNT	DESCRIPTION	2020-21 ACTIVITY	2021-22 ACTIVITY	2022-23 ACTIVITY THRU 09/30/23	2023-24 FINANCE REVIEW BUDGET
Dept 495 - FRC					
ESTIMATED REVENUES					
41100	PROPERTY TAX		18,229	14,437	14,440
	TOTAL ESTIMATED REVENUES		18,229	14,437	14,440
APPROPRIATIONS					
59020	INTEREST AND FISCAL FEES		9,630	23,036	14,440
	TOTAL APPROPRIATIONS		9,630	23,036	14,440
NET OF REVENUES/APPROPRIATIONS - 495 - FRC			8,599	(8,599)	

Calculations as of 09/30/2023

ACCOUNT	DESCRIPTION	2020-21 ACTIVITY	2021-22 ACTIVITY	2022-23 ACTIVITY THRU 09/30/23	2023-24 FINANCE REVIEW BUDGET
Dept 496 - STARBUCKS					
ESTIMATED REVENUES					
41100	PROPERTY TAX		2,016	6,231	6,230
	TOTAL ESTIMATED REVENUES		2,016	6,231	6,230
APPROPRIATIONS					
59010	PRINCIPAL			2,270	6,230
59020	INTEREST AND FISCAL FEES		2,016		
	TOTAL APPROPRIATIONS		2,016	2,270	6,230
NET OF REVENUES/APPROPRIATIONS - 496 - STARBUCKS				3,961	

Calculations as of 09/30/2023

ACCOUNT	DESCRIPTION	2020-21 ACTIVITY	2021-22 ACTIVITY	2022-23 ACTIVITY THRU 09/30/23	2023-24 FINANCE REVIEW BUDGET
Dept 497 - 4J CAPITAL					
ESTIMATED REVENUES					
41100	PROPERTY TAX		223,675	186,144	186,150
	TOTAL ESTIMATED REVENUES		223,675	186,144	186,150
APPROPRIATIONS					
59010	PRINCIPAL		46,498	291,658	186,150
59020	INTEREST AND FISCAL FEES		71,663		
	TOTAL APPROPRIATIONS		118,161	291,658	186,150
NET OF REVENUES/APPROPRIATIONS - 497 - 4J CAPITAL			105,514	(105,514)	

Calculations as of 09/30/2023

ACCOUNT	DESCRIPTION	2020-21 ACTIVITY	2021-22 ACTIVITY	2022-23 ACTIVITY THRU 09/30/23	2023-24 FINANCE REVIEW BUDGET
Dept 498 - 23RD STREET CORRIDOR					
ESTIMATED REVENUES					
41100	PROPERTY TAX		35,406	37,432	60,000
	TOTAL ESTIMATED REVENUES		35,406	37,432	60,000
APPROPRIATIONS					
58100	TRANSFERS OUT				60,000
	TOTAL APPROPRIATIONS				60,000
NET OF REVENUES/APPROPRIATIONS - 498 - 23RD STREET CC			35,406	37,432	

Calculations as of 09/30/2023

ACCOUNT	DESCRIPTION	2020-21 ACTIVITY	2021-22 ACTIVITY	2022-23 ACTIVITY THRU 09/30/23	2023-24 FINANCE REVIEW BUDGET
Dept 499 - SERC LLC					
ESTIMATED REVENUES					
41100	PROPERTY TAX			666	670
TOTAL ESTIMATED REVENUES				666	670
APPROPRIATIONS					
59010	PRINCIPAL			666	670
TOTAL APPROPRIATIONS				666	670
NET OF REVENUES/APPROPRIATIONS - 499 - SERC LLC					
ESTIMATED REVENUES - FUND 480		307,583	802,082	665,582	777,440
APPROPRIATIONS - FUND 480		307,581	569,819	909,285	777,440
NET OF REVENUES/APPROPRIATIONS - FUND 480		2	232,263	(243,703)	
BEGINNING FUND BALANCE		67,065	1	232,261	(11,442)
FUND BALANCE ADJUSTMENTS		(67,065)			
ENDING FUND BALANCE		2	232,264	(11,442)	(11,442)

Calculations as of 09/30/2023

ACCOUNT	DESCRIPTION	2020-21 ACTIVITY	2021-22 ACTIVITY	2022-23 ACTIVITY THRU 09/30/23	2023-24 FINANCE REVIEW BUDGET
Dept 500 - WASTEWATER COLLECTION					
ESTIMATED REVENUES					
41300	CITY SALES TAX	61,219	61,892	53,708	64,380
41310	STATE SALES TAX	386,333	394,243	338,045	405,390
42131	SEWER PERMITS	4,000	3,300	1,800	4,000
42310	FINES AND PENALTIES	115,026	32,274	38,243	40,000
44410	SEWER CHARGES	7,397,522	7,661,991	6,485,149	7,500,000
44415	SEWER CONNECTIONS	6,331	3,358		4,000
45510	SPECIAL ASSESS PRINCIPAL		695,584	94,693	
45515	SPECIAL ASSESS INTEREST		152	13,853	
46100	INTEREST	109,777	71,595	311,629	250,000
48000	MISCELLANEOUS REVENUE	24,384	24,841	92,729	28,000
49100	TRANSFERS IN			1,945,043	600,000
49310	BOND PROCEEDS	166,551	166,551		
TOTAL ESTIMATED REVENUES		8,271,143	9,115,781	9,374,892	8,895,770
APPROPRIATIONS					
51100	SALARIES AND WAGES	554,086	523,028	494,142	573,730
51200	OVERTIME	15,818	10,776	12,334	14,860
51300	TEMPORARY AND SEASONAL	6,904	9,214	9,497	9,800
52100	SOCIAL SECURITY	38,019	40,524	37,865	45,780
52200	GROUP INSURANCE	146,765	120,551	118,782	134,700
52300	RETIREMENT	30,328	32,870	25,603	35,320
52600	WORKERS' COMPENSATION	3,873	8,929		8,930
52700	TRAINING AND TUITION	1,352	3,132	3,906	4,000
52710	EMPLOYEE RECRUITMENT/RETENTION	1,337	5,565	833	3,000
52800	UNIFORMS	6,718	6,962	5,594	7,500
53200	PROFESSIONAL SERVICES		824	1,357	2,000
53400	COMPUTER SUPPORT/MAINT	12,661	20,319	18,263	7,000
54310	BUILDING MAINTENANCE	1,886	4,026	1,379	5,200
54320	EQUIPMENT MAINTENANCE	53,400	47,229	51,050	51,500
54330	VEHICLE MAINTENANCE	9,575	7,476	8,948	11,375
54390	SYSTEM MAINTENANCE	109,621	48,106	39,874	100,000
55200	INSURANCE	15,501	12,146	32,888	32,890
55210	CLAIMS AND SETTLEMENTS			853	500
55900	MISCELLANEOUS	2,262	1,504	15	500
55920	MISC FEES	2,483	641	553	2,500
55930	REFUNDS		2,588		1,000
56010	SUPPLIES	670	103	610	1,000
56020	OFFICE SUPPLIES	4,097	2,563	5,170	5,000
56030	CLEANING SUPPLIES/SERVICE	1,404	1,418	167	
56040	POSTAGE AND FREIGHT	26,368	26,918	20,757	30,000
56050	FUEL	29,654	42,704	29,215	32,400
56060	CHEMICALS	3,158	1,993	3,352	3,500
56090	SMALL TOOLS	132	2,063	694	2,000
56190	PERSONAL PROTECTIVE SUPP	330	304	542	1,000
56220	ELECTRICITY	29,594	28,153	20,082	36,000
56230	WATER AND SEWER	427	259	534	1,000
56240	TELEPHONE	4,764	5,479	3,796	10,500
56250	REFUSE	629	336	697	1,000
56650	MEMBERSHIP DUES	2,624	3,491	706	2,400
56690	SALES TAX REMITTANCE	492,556	455,833	389,895	430,000
57200	CAPITAL-LAND & BUILDINGS				500,000
57300	CAPITAL-NEW CONSTRUCTION	(1,253)		2,426,610	2,182,000
57510	CAPITAL-EQUIPMENT	(10,000)		61,084	
57950	DEPRECIATION	542,210	575,792		
58100	TRANSFERS OUT	120,000	120,000	100,000	120,000
59010	PRINCIPAL				50,200
59020	INTEREST AND FISCAL FEES	143,182	137,864	145,903	132,070
TOTAL APPROPRIATIONS		2,403,135	2,311,683	4,073,550	4,592,155
NET OF REVENUES/APPROPRIATIONS - 500 - WASTEWATER COI		5,868,008	6,804,098	5,301,342	4,303,615

Calculations as of 09/30/2023

ACCOUNT	DESCRIPTION	2020-21 ACTIVITY	2021-22 ACTIVITY	2022-23 ACTIVITY THRU 09/30/23	2023-24 FINANCE REVIEW BUDGET
Dept 501 - WASTEWATER TREATMENT FAC					
ESTIMATED REVENUES					
46100	INTEREST	22,736	9,540	36,283	48,000
48000	MISCELLANEOUS REVENUE	39,550	25	388	
49100	TRANSFERS IN	1,045			
49310	BOND PROCEEDS	203,484	203,484		
TOTAL ESTIMATED REVENUES		266,815	213,049	36,671	48,000
APPROPRIATIONS					
51100	SALARIES AND WAGES	445,773	517,909	449,289	522,050
51200	OVERTIME	19,745	18,729	14,732	17,210
51300	TEMPORARY AND SEASONAL			362	
52100	SOCIAL SECURITY	35,742	37,865	33,004	41,260
52200	GROUP INSURANCE	124,858	129,976	130,302	148,750
52300	RETIREMENT	25,099	29,001	23,268	32,360
52600	WORKERS' COMPENSATION	5,069	9,203	5,141	9,210
52700	TRAINING AND TUITION	1,400	3,763	4,043	5,500
52710	EMPLOYEE RECRUITMENT/RETENTION	109	2,072	169	1,250
52800	UNIFORMS	4,982	5,053	4,332	6,300
53200	PROFESSIONAL SERVICES		75		1,500
53400	COMPUTER SUPPORT/MAINT	1,302	3,430	822	4,000
54310	BUILDING MAINTENANCE	328	1,434	2,031	3,660
54320	EQUIPMENT MAINTENANCE	57,054	68,341	58,944	80,000
54330	VEHICLE MAINTENANCE	805	1,767	641	2,150
54390	SYSTEM MAINTENANCE			83	
55200	INSURANCE	58,913	63,756	71,088	71,090
55640	COMPLIANCE TESTING	9,477	7,912	8,871	12,000
55900	MISCELLANEOUS	6,720			600
56010	SUPPLIES	4,047	6,106	4,373	7,210
56020	OFFICE SUPPLIES	1,073	116	40	2,000
56030	CLEANING SUPPLIES/SERVICE	969	850	727	1,200
56040	POSTAGE AND FREIGHT	3	208	120	500
56050	FUEL	7,303	12,880	10,793	12,960
56060	CHEMICALS	170,503	191,283	183,285	214,920
56090	SMALL TOOLS	1,120	706	475	1,270
56100	LABORATORY	9,576	11,122	7,686	16,200
56190	PERSONAL PROTECTIVE SUPP				250
56210	NATURAL GAS	34,726	52,759	59,000	62,500
56220	ELECTRICITY	177,014	172,017	122,748	180,000
56230	WATER AND SEWER	71,122	23,720	27,122	35,000
56240	TELEPHONE	2,153	2,112	2,171	3,070
56250	REFUSE	1,876	1,749	1,318	2,000
56650	MEMBERSHIP DUES	768	2,020	1,091	2,000
57200	CAPITAL-LAND & BUILDINGS	428,168			
57510	CAPITAL-EQUIPMENT			48,624	
57950	DEPRECIATION	1,335,931	1,334,274		
59010	PRINCIPAL				1,539,770
59020	INTEREST AND FISCAL FEES	1,232,397	1,190,256	1,159,207	1,125,590
TOTAL APPROPRIATIONS		4,276,125	3,902,464	2,435,902	4,165,330
NET OF REVENUES/APPROPRIATIONS - 501 - WASTEWATER TRE		(4,009,310)	(3,689,415)	(2,399,231)	(4,117,330)
ESTIMATED REVENUES - FUND 500		8,537,958	9,328,830	9,411,563	8,943,770
APPROPRIATIONS - FUND 500		6,679,260	6,214,147	6,509,452	8,757,485
NET OF REVENUES/APPROPRIATIONS - FUND 500		1,858,698	3,114,683	2,902,111	186,285
BEGINNING FUND BALANCE		21,812,601	23,546,419	26,655,473	29,557,584
FUND BALANCE ADJUSTMENTS		(124,880)	(5,629)		
ENDING FUND BALANCE		23,546,419	26,655,473	29,557,584	29,743,869

Calculations as of 09/30/2023

ACCOUNT	DESCRIPTION	2020-21 ACTIVITY	2021-22 ACTIVITY	2022-23 ACTIVITY THRU 09/30/23	2023-24 FINANCE REVIEW BUDGET
Dept 520 - WATER					
ESTIMATED REVENUES					
41300	CITY SALES TAX	35,055	6,082	4,928	6,500
41310	STATE SALES TAX	135,443	26,882	21,918	26,000
42132	WATER PERMITS	59,106	61,255	29,203	60,000
42310	FINES AND PENALTIES	48,509	19,411	20,903	25,000
44440	WATER SALES	4,168,872	4,109,000	3,369,027	4,000,000
44445	WATER CONNECTIONS		4,043		500
45310	BUILDING RENTALS	188,520	179,192	142,600	163,720
45325	LAND RENTALS	40,936	42,305	42,032	43,000
45510	SPECIAL ASSESS PRINCIPAL		132,919	28,279	
45515	SPECIAL ASSESS INTEREST		58	3,507	
46100	INTEREST	104,731	70,633	314,024	340,000
48000	MISCELLANEOUS REVENUE	39,016	29,003	24,920	30,000
48100	REFUNDS	240			
49100	TRANSFERS IN			625,000	
49310	BOND PROCEEDS	159,140	151,599		
TOTAL ESTIMATED REVENUES		4,979,568	4,832,382	4,626,341	4,694,720
APPROPRIATIONS					
51100	SALARIES AND WAGES	453,879	637,126	590,591	685,060
51200	OVERTIME	27,973	20,984	20,769	24,040
51300	TEMPORARY AND SEASONAL	6,904	7,725	2,786	2,810
52100	SOCIAL SECURITY	50,187	49,789	44,530	54,470
52200	GROUP INSURANCE	158,338	159,804	163,411	185,970
52300	RETIREMENT	33,191	39,306	30,882	42,550
52500	UNEMPLOYMENT	4,241			1,000
52600	WORKERS' COMPENSATION	6,719	2,636	(4,482)	3,000
52700	TRAINING AND TUITION	5,402	9,505	3,344	10,600
52710	EMPLOYEE RECRUITMENT/RETENTION	2,251	2,975	883	1,700
52800	UNIFORMS	2,843	3,835	3,833	4,120
53200	PROFESSIONAL SERVICES		1,024	1,357	2,120
53400	COMPUTER SUPPORT/MAINT	15,119	24,211	21,394	14,700
54310	BUILDING MAINTENANCE	4,534	6,728	3,213	10,000
54320	EQUIPMENT MAINTENANCE	19,391	10,753	24,432	34,000
54330	VEHICLE MAINTENANCE	3,820	4,101	3,990	5,000
54390	SYSTEM MAINTENANCE	152,524	199,446	167,408	250,000
54420	WELL MAINTENANCE	75,227	82,219	52,747	123,000
54520	EQUIPMENT RENTAL/PURCHASE				400
55200	INSURANCE	27,101	28,177	40,551	40,500
55210	CLAIMS AND SETTLEMENTS	10,254	2,721	853	
55400	ADVERTISING AND PROMOTION	173	476	199	500
55640	COMPLIANCE TESTING	9,164	7,904	5,591	15,000
55900	MISCELLANEOUS	5,179	1,332	577	500
55910	OVER/SHORT	(162)	4	26	
55920	MISC FEES	2,483	619	525	2,370
55930	REFUNDS		3,933		
55950	COVID-19 EXPENSES	3			
56010	SUPPLIES	907	561	906	2,000
56020	OFFICE SUPPLIES	4,579	3,863	5,793	5,400
56030	CLEANING SUPPLIES/SERVICE	2,685	2,815	167	1,500
56040	POSTAGE AND FREIGHT	27,209	28,056	22,195	24,000
56050	FUEL	97	1,002	192	1,300
56060	CHEMICALS	193,406	229,610	230,756	250,000
56090	SMALL TOOLS	1,346	2,408	551	2,200
56100	LABORATORY	1,320	2,757	4,589	4,500
56130	SUPPLIES FOR RESALE	1,033	62,397	33,066	45,000
56135	AMR RADIO EXPENSE	109,204	107,529	83,346	196,000
56190	PERSONAL PROTECTIVE SUPP	102	395	184	1,100
56210	NATURAL GAS	6,579	10,595	11,885	13,000
56220	ELECTRICITY	162,108	173,798	125,263	144,200
56230	WATER AND SEWER	2,408	3,405	1,759	3,000
56240	TELEPHONE	5,275	7,167	8,348	10,175
56250	REFUSE	239	243	416	800
56650	MEMBERSHIP DUES	2,771	3,618	706	3,000
56690	SALES TAX REMITTANCE	210,294	55,464	54,109	55,000
57200	CAPITAL-LAND & BUILDINGS	(544,023)		1,562,181	1,832,000
57300	CAPITAL-NEW CONSTRUCTION	135,729	(83)	371,218	372,000
57510	CAPITAL-EQUIPMENT	189,271			295,000
57950	DEPRECIATION	886,630	845,454		
58100	TRANSFERS OUT	120,000	120,000	100,000	120,000
59010	PRINCIPAL				225,040
59020	INTEREST AND FISCAL FEES	124,962	166,872	158,542	157,760
TOTAL APPROPRIATIONS		2,720,869	3,135,259	3,955,582	5,277,385
NET OF REVENUES/APPROPRIATIONS - 520 - WATER		2,258,699	1,697,123	670,759	(582,665)

Calculations as of 09/30/2023

ACCOUNT	DESCRIPTION	2020-21 ACTIVITY	2021-22 ACTIVITY	2022-23 ACTIVITY THRU 09/30/23	2023-24 FINANCE REVIEW BUDGET
Dept 522 - SUPERFUND PROJECT					
ESTIMATED REVENUES					
43102	FEDERAL GRANTS		31,184		
43410	STATE GRANTS	36,318	267		
48000	MISCELLANEOUS REVENUE	787			
	TOTAL ESTIMATED REVENUES	37,105	31,451		
APPROPRIATIONS					
54320	EQUIPMENT MAINTENANCE	31,095	21,623		
56220	ELECTRICITY	3,229	3,658	112	
57950	DEPRECIATION	37,736	37,736		
	TOTAL APPROPRIATIONS	72,060	63,017	112	
NET OF REVENUES/APPROPRIATIONS - 522 - SUPERFUND PROJ		(34,955)	(31,566)	(112)	
ESTIMATED REVENUES - FUND 520		5,016,673	4,863,833	4,626,341	4,694,720
APPROPRIATIONS - FUND 520		2,792,929	3,198,276	3,955,694	5,277,385
NET OF REVENUES/APPROPRIATIONS - FUND 520		2,223,744	1,665,557	670,647	(582,665)
BEGINNING FUND BALANCE		25,660,764	27,884,507	29,006,039	29,676,686
FUND BALANCE ADJUSTMENTS			(544,022)		
ENDING FUND BALANCE		27,884,508	29,006,042	29,676,686	29,094,021

Calculations as of 09/30/2023

ACCOUNT	DESCRIPTION	2020-21 ACTIVITY	2021-22 ACTIVITY	2022-23 ACTIVITY THRU 09/30/23	2023-24 FINANCE REVIEW BUDGET
Dept 530 - LOUP DISTRIBUTION					
ESTIMATED REVENUES					
41820	OCCUPATION/FRANCHISE TAX	4,140,755	4,282,510	3,453,385	4,600,000
46100	INTEREST	13,452	10,160	37,482	39,000
49100	TRANSFERS IN	64,956			7,495
	TOTAL ESTIMATED REVENUES	<u>4,219,163</u>	<u>4,292,670</u>	<u>3,490,867</u>	<u>4,646,495</u>
APPROPRIATIONS					
57950	DEPRECIATION	163,666	163,666		
58100	TRANSFERS OUT	3,951,440	4,021,440	3,952,703	4,646,495
	TOTAL APPROPRIATIONS	<u>4,115,106</u>	<u>4,185,106</u>	<u>3,952,703</u>	<u>4,646,495</u>
NET OF REVENUES/APPROPRIATIONS - 530 - LOUP DISTRIBU		<u>104,057</u>	<u>107,564</u>	<u>(461,836)</u>	
ESTIMATED REVENUES - FUND 530		4,219,163	4,292,670	3,490,867	4,646,495
APPROPRIATIONS - FUND 530		4,115,106	4,185,106	3,952,703	4,646,495
NET OF REVENUES/APPROPRIATIONS - FUND 530		104,057	107,564	(461,836)	
	BEGINNING FUND BALANCE	5,559,399	5,663,455	5,771,019	5,309,183
	ENDING FUND BALANCE	5,663,456	5,771,019	5,309,183	5,309,183

Calculations as of 09/30/2023

ACCOUNT	DESCRIPTION	2020-21 ACTIVITY	2021-22 ACTIVITY	2022-23 ACTIVITY THRU 09/30/23	2023-24 FINANCE REVIEW BUDGET
Dept 560 - STORMWATER UTILITY					
ESTIMATED REVENUES					
41300	CITY SALES TAX	5,196	5,240	4,400	5,280
41310	STATE SALES TAX	19,382	19,553	16,408	19,690
42310	FINES AND PENALTIES	2,999	3,102	2,793	3,360
44420	STORMWATER FEES	354,586	359,662	301,503	361,660
46100	INTEREST	5,581	5,129	23,154	24,000
TOTAL ESTIMATED REVENUES		387,744	392,686	348,258	413,990
APPROPRIATIONS					
51100	SALARIES AND WAGES	19,259	25,183	24,933	28,890
51200	OVERTIME	9		2	
52100	SOCIAL SECURITY	1,697	1,843	1,845	2,210
52200	GROUP INSURANCE	5,105	4,401	4,219	4,810
52300	RETIREMENT	1,354	1,511	1,275	1,740
52600	WORKERS' COMPENSATION	305			310
52700	TRAINING AND TUITION	557	868	594	1,000
52710	EMPLOYEE RECRUITMENT/RETENTION	460			500
52800	UNIFORMS		124	17	100
53200	PROFESSIONAL SERVICES		428	3,705	50,000
53400	COMPUTER SUPPORT/MAINT	2,430	5,920	5,031	9,000
54320	EQUIPMENT MAINTENANCE				100
54330	VEHICLE MAINTENANCE	15		15	300
55200	INSURANCE	562	529		570
55400	ADVERTISING AND PROMOTION	2,051	750	1,279	4,000
55500	PUBLICATIONS AND NOTICES		405		500
55640	COMPLIANCE TESTING				2,000
55900	MISCELLANEOUS		5,858	723	1,000
56010	SUPPLIES	1,361	678	759	1,250
56020	OFFICE SUPPLIES		65	640	1,000
56040	POSTAGE AND FREIGHT				250
56050	FUEL	32	178	128	200
56190	PERSONAL PROTECTIVE SUPP		30		70
56230	WATER AND SEWER	440	343	429	500
56650	MEMBERSHIP DUES	320	105	105	200
56690	SALES TAX REMITTANCE	26,686	24,493	20,716	24,000
57200	CAPITAL-LAND & BUILDINGS				500,000
57300	CAPITAL-NEW CONSTRUCTION			6,840	125,000
57510	CAPITAL-EQUIPMENT				50,000
57950	DEPRECIATION	388,453	388,598		
TOTAL APPROPRIATIONS		451,096	462,310	73,255	809,500
NET OF REVENUES/APPROPRIATIONS - 560 - STORMWATER UTI		(63,352)	(69,624)	275,003	(395,510)
ESTIMATED REVENUES - FUND 560		387,744	392,686	348,258	413,990
APPROPRIATIONS - FUND 560		451,096	462,310	73,255	809,500
NET OF REVENUES/APPROPRIATIONS - FUND 560		(63,352)	(69,624)	275,003	(395,510)
BEGINNING FUND BALANCE		11,548,626	11,485,494	11,415,872	11,690,875
FUND BALANCE ADJUSTMENTS		222			
ENDING FUND BALANCE		11,485,496	11,415,870	11,690,875	11,295,365

Calculations as of 09/30/2023

ACCOUNT	DESCRIPTION	2020-21 ACTIVITY	2021-22 ACTIVITY	2022-23 ACTIVITY THRU 09/30/23	2023-24 FINANCE REVIEW BUDGET
Dept 570 - TRANSFER STATION					
ESTIMATED REVENUES					
41820	OCCUPATION/FRANCHISE TAX	702,849	666,049	577,387	700,000
42102	GARBAGE HAULER LICENSES	900	1,200	1,200	1,200
42310	FINES AND PENALTIES	2,161	2,231	2,010	2,500
43410	STATE GRANTS	18,907		27,098	20,000
44150	FUEL	4,422	7,015	7,350	8,000
44430	COMPACTOR FEES	1,731,832	1,805,568	1,503,439	1,750,000
46100	INTEREST	22,363	15,393	72,227	78,180
48000	MISCELLANEOUS REVENUE	14,333	22,884	7,358	6,500
49210	LAND OR PROPERTY SALES			92	
TOTAL ESTIMATED REVENUES		2,497,767	2,520,340	2,198,161	2,566,380
APPROPRIATIONS					
51100	SALARIES AND WAGES	450,839	452,962	394,905	459,500
51200	OVERTIME	10,420	18,773	12,849	15,500
51300	TEMPORARY AND SEASONAL	13,095	10,679	6,501	7,170
52100	SOCIAL SECURITY	34,309	36,803	30,669	36,890
52200	GROUP INSURANCE	127,267	88,630	83,930	95,850
52300	RETIREMENT	26,487	28,988	18,729	28,500
52600	WORKERS' COMPENSATION	7,563	2,458	2,424	3,500
52700	TRAINING AND TUITION	73	783	1,460	2,600
52710	EMPLOYEE RECRUITMENT/RETENTION	1,790	4,495	993	2,000
52800	UNIFORMS	5,462	4,900	5,056	5,630
53200	PROFESSIONAL SERVICES	2,008	1,791	650	2,000
53400	COMPUTER SUPPORT/MAINT	2,864	6,968	8,359	10,900
54310	BUILDING MAINTENANCE	16,935	3,193	1,468	40,000
54320	EQUIPMENT MAINTENANCE	18,326	13,112	15,937	17,500
54330	VEHICLE MAINTENANCE	44,128	47,112	71,604	50,000
54550	LANDFILL DISPOSAL	725,888	708,007	456,569	730,000
54580	COMPOSTING	11,472	86,577	28,710	40,000
54590	RECYCLE SERVICE				4,000
54610	WOOD WASTE DISPOSAL	26,125	25,000	21,500	30,000
55200	INSURANCE	11,047	12,000	21,825	21,700
55210	CLAIMS AND SETTLEMENTS		8,625		
55900	MISCELLANEOUS	105	462	463	700
55930	REFUNDS	(40)			
56010	SUPPLIES	434	587	822	760
56020	OFFICE SUPPLIES	69	2,225	2,117	2,000
56030	CLEANING SUPPLIES/SERVICE	869	879	802	900
56040	POSTAGE AND FREIGHT	11			100
56050	FUEL	91,908	148,393	123,097	140,400
56090	SMALL TOOLS	440	662	488	2,000
56190	PERSONAL PROTECTIVE SUPP		32	63	500
56220	ELECTRICITY	8,445	8,049	6,972	10,000
56230	WATER AND SEWER	3,630	3,788	2,942	4,400
56240	TELEPHONE	800	671	624	1,600
56650	MEMBERSHIP DUES	686	686	739	7,000
56800	WASTE GRANT EXPENSE	18,907		50,515	25,000
57200	CAPITAL-LAND & BUILDINGS				40,000
57510	CAPITAL-EQUIPMENT			230,840	175,000
57520	CAPITAL-VEHICLES				175,000
57950	DEPRECIATION	229,382	212,054		
58100	TRANSFERS OUT	113,956	49,000	40,833	56,495
59010	PRINCIPAL			220,000	225,000
59020	INTEREST AND FISCAL FEES	15,732	12,183	5,135	7,495
TOTAL APPROPRIATIONS		2,021,432	2,001,527	1,870,590	2,477,590
NET OF REVENUES/APPROPRIATIONS - 570 - TRANSFER STATI		476,335	518,813	327,571	88,790
ESTIMATED REVENUES - FUND 570		2,497,767	2,520,340	2,198,161	2,566,380
APPROPRIATIONS - FUND 570		2,021,432	2,001,527	1,870,590	2,477,590
NET OF REVENUES/APPROPRIATIONS - FUND 570		476,335	518,813	327,571	88,790
BEGINNING FUND BALANCE		3,854,854	4,331,188	4,846,138	5,173,709
FUND BALANCE ADJUSTMENTS		1	(3,863)		
ENDING FUND BALANCE		4,331,190	4,846,138	5,173,709	5,262,499

ACCOUNT	DESCRIPTION	2020-21 ACTIVITY	2021-22 ACTIVITY	2022-23 ACTIVITY THRU 09/30/23	2023-24 FINANCE REVIEW BUDGET
Dept 600 - HEALTH INSURANCE					
ESTIMATED REVENUES					
44115	ADMINISTRATIVE FEES	76,088	61,573	63,261	75,000
44160	HEALTH INSURANCE PREMIUMS	2,083,647	26,498	30,666	41,000
44170	DENTAL INSURANCE PREMIUMS	58,331			
46100	INTEREST	25,182	12,463	52,964	58,000
48100	REFUNDS	27	175		200
TOTAL ESTIMATED REVENUES		2,243,275	100,709	146,891	174,200
APPROPRIATIONS					
52200	GROUP INSURANCE	59,484	44,856	46,333	55,600
52300	RETIREMENT	16,402	17,031	16,630	20,000
53600	HEALTH ADMINISTRATION	495,680	453,394	643,604	775,000
53610	HEALTH CLAIMS	1,786,924	(473,381)	(852,757)	(688,040)
53620	DENTAL ADMINISTRATION	1,194			
53630	DENTAL CLAIMS	57,241	3	1,960	11,640
TOTAL APPROPRIATIONS		2,416,925	41,903	(144,230)	174,200
NET OF REVENUES/APPROPRIATIONS - 600 - HEALTH INSURAN		(173,650)	58,806	291,121	
ESTIMATED REVENUES - FUND 600		2,243,275	100,709	146,891	174,200
APPROPRIATIONS - FUND 600		2,416,925	41,903	(144,230)	174,200
NET OF REVENUES/APPROPRIATIONS - FUND 600		(173,650)	58,806	291,121	
BEGINNING FUND BALANCE		2,525,442	2,124,957	2,183,764	2,474,885
FUND BALANCE ADJUSTMENTS		(226,836)			
ENDING FUND BALANCE		2,124,956	2,183,763	2,474,885	2,474,885

Calculations as of 09/30/2023

ACCOUNT	DESCRIPTION	2020-21 ACTIVITY	2021-22 ACTIVITY	2022-23 ACTIVITY THRU 09/30/23	2023-24 FINANCE REVIEW BUDGET
Dept 700 - POLICE PENSION					
ESTIMATED REVENUES					
46100	INTEREST	264			
TOTAL ESTIMATED REVENUES		264			
APPROPRIATIONS					
58100	TRANSFERS OUT	60,056			
TOTAL APPROPRIATIONS		60,056			
NET OF REVENUES/APPROPRIATIONS - 700 - POLICE PENSION		(59,792)			
ESTIMATED REVENUES - FUND 700		264			
APPROPRIATIONS - FUND 700		60,056			
NET OF REVENUES/APPROPRIATIONS - FUND 700		(59,792)			
BEGINNING FUND BALANCE		59,791			
ENDING FUND BALANCE		(1)			

Calculations as of 09/30/2023

ACCOUNT	DESCRIPTION	2020-21 ACTIVITY	2021-22 ACTIVITY	2022-23 ACTIVITY THRU 09/30/23	2023-24 FINANCE REVIEW BUDGET
Dept 710 - FIRE PENSION					
ESTIMATED REVENUES					
46100	INTEREST	714	450	1,761	1,950
49100	TRANSFERS IN	68,156			
	TOTAL ESTIMATED REVENUES	68,870	450	1,761	1,950
APPROPRIATIONS					
52350	PENSION PAYMENTS	16,452	9,594	6,699	7,310
	TOTAL APPROPRIATIONS	16,452	9,594	6,699	7,310
NET OF REVENUES/APPROPRIATIONS - 710 - FIRE PENSION		52,418	(9,144)	(4,938)	(5,360)
ESTIMATED REVENUES - FUND 710		68,870	450	1,761	1,950
APPROPRIATIONS - FUND 710		16,452	9,594	6,699	7,310
NET OF REVENUES/APPROPRIATIONS - FUND 710		52,418	(9,144)	(4,938)	(5,360)
	BEGINNING FUND BALANCE	40,996	93,414	84,270	79,332
	ENDING FUND BALANCE	93,414	84,270	79,332	73,972

ACCOUNT	DESCRIPTION	2020-21 ACTIVITY	2021-22 ACTIVITY	2022-23 ACTIVITY THRU 09/30/23	2023-24 FINANCE REVIEW BUDGET
Dept 730 - LICENSES TO SCHOOLS					
ESTIMATED REVENUES					
42101	LIQUOR AND BEER LICENSES	8,175	15,600	15,150	15,150
42105	TOBACCO LICENSES	610	640	618	620
TOTAL ESTIMATED REVENUES		8,785	16,240	15,768	15,770
APPROPRIATIONS					
56710	SCHOOL DISTRICT	16,885	11,545	20,198	15,770
TOTAL APPROPRIATIONS		16,885	11,545	20,198	15,770
NET OF REVENUES/APPROPRIATIONS - 730 - LICENSES TO SC		(8,100)	4,695	(4,430)	
ESTIMATED REVENUES - FUND 730		8,785	16,240	15,768	15,770
APPROPRIATIONS - FUND 730		16,885	11,545	20,198	15,770
NET OF REVENUES/APPROPRIATIONS - FUND 730		(8,100)	4,695	(4,430)	
BEGINNING FUND BALANCE		8,100		4,695	265
ENDING FUND BALANCE			4,695	265	265

ACCOUNT	DESCRIPTION	2020-21 ACTIVITY	2021-22 ACTIVITY	2022-23 ACTIVITY THRU 09/30/23	2023-24 FINANCE REVIEW BUDGET
Dept 740 - LIBRARY FOUNDATION					
ESTIMATED REVENUES					
46100	INTEREST	11,304	12,226		10,000
47500	DONATIONS	848,231	52,360		
	TOTAL ESTIMATED REVENUES	859,535	64,586		10,000
APPROPRIATIONS					
53200	PROFESSIONAL SERVICES	10,202	996		
53220	FUND RAISING EXPENSE				500
55400	ADVERTISING AND PROMOTION				500
55900	MISCELLANEOUS				150
	TOTAL APPROPRIATIONS	10,202	996		1,150
NET OF REVENUES/APPROPRIATIONS - 740 - LIBRARY FOUNDATION		849,333	63,590		8,850
ESTIMATED REVENUES - FUND 740		859,535	64,586		10,000
APPROPRIATIONS - FUND 740		10,202	996		1,150
NET OF REVENUES/APPROPRIATIONS - FUND 740		849,333	63,590		8,850
	BEGINNING FUND BALANCE	2,558,890	3,408,223	3,471,813	3,471,813
	ENDING FUND BALANCE	3,408,223	3,471,813	3,471,813	3,480,663

Calculations as of 09/30/2023

ACCOUNT	DESCRIPTION	2020-21 ACTIVITY	2021-22 ACTIVITY	2022-23 ACTIVITY THRU 09/30/23	2023-24 FINANCE REVIEW BUDGET
Dept 745 - LIBRARY ENDOWMENT					
ESTIMATED REVENUES					
46100	INTEREST				2,000
46200	CHANGE IN MARKET VALUE	216,573	(5,131)		15,000
46300	REALIZED GAINS/LOSSES		(5,131)		20,000
	TOTAL ESTIMATED REVENUES	<u>216,573</u>	<u>(10,262)</u>		<u>37,000</u>
NET OF REVENUES/APPROPRIATIONS - 745 - LIBRARY ENDOWM					
		<u>216,573</u>	<u>(10,262)</u>		<u>37,000</u>
ESTIMATED REVENUES - FUND 745					
		216,573	(10,262)		37,000
APPROPRIATIONS - FUND 745					
NET OF REVENUES/APPROPRIATIONS - FUND 745					
		216,573	(10,262)		37,000
	BEGINNING FUND BALANCE	1,859,178	2,075,751	2,065,489	2,065,489
	ENDING FUND BALANCE	2,075,751	2,065,489	2,065,489	2,102,489

Calculations as of 09/30/2023

ACCOUNT	DESCRIPTION	2020-21 ACTIVITY	2021-22 ACTIVITY	2022-23 ACTIVITY THRU 09/30/23	2023-24 FINANCE REVIEW BUDGET
Dept 750 - GERRARD PARK TRUST					
ESTIMATED REVENUES					
46100	INTEREST	4,120	5,445	2,780	5,500
46200	CHANGE IN MARKET VALUE	10,441	(33,645)	7,256	7,500
46300	REALIZED GAINS/LOSSES	2,019	3,589	2,435	4,000
TOTAL ESTIMATED REVENUES		16,580	(24,611)	12,471	17,000
APPROPRIATIONS					
53200	PROFESSIONAL SERVICES	2,201	2,500	1,969	2,100
58100	TRANSFERS OUT	1,660		1,806	4,000
TOTAL APPROPRIATIONS		3,861	2,500	3,775	6,100
NET OF REVENUES/APPROPRIATIONS - 750 - GERRARD PARK T		12,719	(27,111)	8,696	10,900
ESTIMATED REVENUES - FUND 750		16,580	(24,611)	12,471	17,000
APPROPRIATIONS - FUND 750		3,861	2,500	3,775	6,100
NET OF REVENUES/APPROPRIATIONS - FUND 750		12,719	(27,111)	8,696	10,900
BEGINNING FUND BALANCE		144,559	157,277	130,166	138,862
ENDING FUND BALANCE		157,278	130,166	138,862	149,762
ESTIMATED REVENUES - ALL FUNDS		97,914,371	84,043,035	65,917,038	82,568,012
APPROPRIATIONS - ALL FUNDS		65,829,364	71,599,587	72,229,462	89,701,494
NET OF REVENUES/APPROPRIATIONS - ALL FUNDS		32,085,007	12,443,448	(6,312,424)	(7,133,482)
BEGINNING FUND BALANCE - ALL FUNDS		198,008,676	138,905,669	231,014,700	224,702,276
FUND BALANCE ADJUSTMENTS - ALL FUNDS		(91,188,018)	79,665,581		
ENDING FUND BALANCE - ALL FUNDS		138,905,665	231,014,698	224,702,276	217,568,794

11. **REPORTS OF SPECIAL COMMITTEES - None**

12. **REPORTS ON LEGISLATION - None**

13. **NEW BUSINESS**

13.A. Quote from Security Equipment, Inc. in the amount of \$14,714 for modifications to access control system at Columbus Community Building for improved control of secure areas.



Information Technology

☎ 402-562-4242

📠 402-562-4265

@ it@columbusne.us

City of Columbus

City Hall

2424 14th St.

P. O. Box 1677

Columbus, NE 68602

MEMORANDUM

DATE: 8/29/2023
TO: City Administrator / Mayor / City Council
FROM: Matt Soukup, Computer Network Technician
RE: Community Building Access Control Changes

RECOMMENDATION:

I recommend the approval for changes to the Community Building access control system.

DISCUSSION:

These changes and additions are needed to better work with changes in the design of some areas of the Community Building. They will also allow better control of secure areas of the building.

- Adding access control to 1st floor data room and library customer service office.
- Adding access control to Coffee Shop gate to restrict access to open and close the gate.
- Adding release buttons at City Hall reception desk to allow entry into office area.
- Remove readers from Library main entrance, Children's Museum main entrance, Library 2nd floor entrance due to changes to the door hardware.
- Remove readers from City Hall balcony door due to fire requirements.

FISCAL IMPACT:

Initial cost will be \$14,714.00.

CONCURRENCE:

None at this time.

ALTERNATIVES:

Staff makes no alternative recommendation.

SIGNATURE:

By: 
Matt Soukup, Computer Network Technician

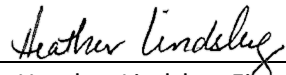
Approved By: 
Heather Lindsley, Finance Director

Approved By: 
Tara Vasicek, City Administrator



Your Safety Is Our Business
secure • monitor • connect

City Of Columbus

Columbus Community Building Additional Projects

61116-14-0
Dated: 8/29/2023

Prepared for:
Matt Soukup

Customer: City Of Columbus

Site: 2500 14 Street
Columbus, NE, 68601

Contact: Matt Soukup | 402-562-4242 | Msoukup@Columbusne.Us



Your Safety Is Our Business
secure • monitor • connect

Proposal #: 61116-14-0

Dated: 8/29/2023

Columbus Community Building Additional Projects

Scope of Work

SEI to provide and install card readers on the following doors:

#117 Data Room

#105.2 Gate control of open/close/stop for Coffee shop electronic roll up door

#107 Customer Service

All readers will be added to open ports on the existing AMAG panels

All locks will be added to the existing low voltage lock power supplies

SEI to provide and install release buttons at the Library front desk for door 103.1 and at the Children's Museum front desk for door 126.2

SEI to remove reader from Library 2nd floor main entry door 235.1 and adjust existing door schedule

SEI to provide and install door release button at the office front desk for doors #320.2 and #325

SEI to remove the reader from the 3rd floor staff balcony door #301. This will become a status only door

Prepared by: Robb Walker • Major Accounts Executive

rwalker@seisecurity.com • seisecurity.com

2238 S 156 Circle Omaha, NE 68130 | P: (402)-778-3759 | F: (402)-333-7616

Customer: City Of Columbus
Site: 2500 14 Street
 Columbus, NE, 68601
Contact: Matt Soukup | 402-562-4242 | Msoukup@Columbusne.us



Your Safety Is Our Business
 secure • monitor • connect

Proposal #: 61116-14-0
Dated: 8/29/2023

Schedule of Protection

1st Floor CM Data Closet Reader #117

QTY	Description
1	RP40 Multiclass Reader, Black
1	1" Recessed Wide Gap Contact, Brown
1	Request to Exit Sensor
1	6210-FSE-24VDC-32D
75	Composite Plenum Shielded Wire

1st Floor Coffee Shop Reader #105.2

QTY	Description
1	RP40 Multiclass Reader, Black
1	Isolation Relay
1	Altronix ST1 Snap Track for Altronix RB5, RB1224,
200	Composite Plenum Shielded Wire

1st Floor Customer Service Reader #107

QTY	Description
1	RP40 Multiclass Reader, Black
1	1" Recessed Wide Gap Contact, Brown
1	Request to Exit Sensor
1	6210-FSE-24VDC-32D
200	Composite Plenum Shielded Wire

1st Floor Library and CM Hold Open Release #103.1 and #126.2

QTY	Description
2	Push Button, Momentary, Surface Mounted
300	18/2 Plenum Non Shielded Wire

2nd Floor Main Library Doors #235.1

QTY	Description
1	SEi Labor

3rd Floor Reception Door Releases #320.2 and #325

QTY	Description
2	Push Button, Momentary, Surface Mounted
200	18/2 Plenum Non Shielded Wire
2	Wireless Transmitter with flying leads
2	Wireless Reciever
2	Mounting Box

3rd Floor Staff Balcony Door #301

QTY	Description
1	SEi Labor

Customer: City Of Columbus
Site: 2500 14 Street
Columbus, NE, 68601
Contact: Matt Soukup | 402-562-4242 | Msoukup@Columbusne.US



Your Safety Is Our Business
secure • monitor • connect

Proposal #: 61116-14-0
Dated: 8/29/2023

Investment Summary

Deposit Due in Advance	\$7,357.00
Balance Due Upon Completion	\$7,357.00
Total Proposal Amount	\$14,714.00

Note: The above price does not include tax

* This proposal for the above described protection is valid for 30 days.

* This proposal for the above described protection does not include tax and is covered by a one (1) year parts, labor and service guarantee



Commercial Installation and Service Agreement

THIS AGREEMENT is made August 29, 2023, by and between SECURITY EQUIPMENT, INC and its directors, officers, shareholders, employees and agents, (collectively "SEi") and City Of Columbus. Location of Customer's premises 2500 14 Street, Columbus, NE 68601.

Subject to the terms and conditions hereinafter set forth, SEi agrees to sell, and provide () of the equipment specified on "**Schedule of Protection**", which is incorporated herein by reference.

Note:

Customer acknowledges and agrees that (1) additional equipment, at additional cost, can provide increased detection ability (2) Customer has voluntarily elected to accept the System based on Customer's business reasons, i.e., cost, firm culture, Premises environment and conditions, insurance requirements, etc. (3) a second telephone line at the Premises is necessary to use the telephone while the System is transmitting data to the monitoring facility (4) if the System includes radio equipment or the System is owned by SEi, Customer shall, at its sole cost, promptly and without demand return the System to SEi at the expiration or termination of this Agreement (5) Customer has voluntarily elected delayed dispatch or no repeat dispatch services for the purpose of reducing false alarms, notwithstanding the increased risk of loss or damage inherent in Customer's decision (6) Customer shall notify SEi of all ordinances or local policies of Proper Authorities that may affect SEi's performance of services to Customer and shall pay all fees and charges which may be assessed to Customer to comply with State or local statutes, ordinances, or regulations and (7) devices, Systems, networks, data and other communications transmitted through radio signals (wireless devices) or the Internet are susceptible to being accessed by others, (e.g., hackers) and Customer hereby releases SEi for and from all damages, losses, costs and associated liabilities arising out of or from, in connection with or related to any third party's access of any such device, System, network, data or other communication related to this Agreement.

Installation Charges:

Customer agrees to pay SEi the sum of: \$14,714.00 plus tax, if applicable

Deposit due upon Prewiring will be 50% If necessary, remaining balance will be due upon substantial completion of installation.

Recurring Charges:

Customer agrees to pay SEi the sum of \$0.00 plus tax, if applicable per month for the lease or purchase of the system. included in this proposal, prepaid for a period of five years. Method of payment by Customer may be by check, money order, credit card or EFT (Electronic Funds Transfer). If EFT is desired Customer authorizes periodic debits from Customer's bank account as stated above.

NOTICE TO CUSTOMER: CUSTOMER SPECIFICALLY ACKNOWLEDGES AND ACCEPTS THE DISCLAIMER/LIMITATION OF LIABILITY AND INDEMNITY PARAGRAPHS HEREOF. TERMS AND CONDITIONS ARE AN INTEGRAL PART OF THIS AGREEMENT. CUSTOMER ACKNOWLEDGES RECEIPT OF A COPY OF CONTRACT. READ ALL PAGES BEFORE SIGNING.

Electronic Signatures:

The person signing this Agreement certifies that Customer's policies do not prohibit the acceptance and execution of terms and conditions in electronic form. In addition, each party consents to and agrees that the use of a keyboard, mouse, or other device (1) to select an item, button, icon or checkbox or (2) to enter text, or (3) to perform any similar act or action while using SEi's web-based portal(s) for the purpose of initiating, reviewing, modifying or completing any transaction regarding this Agreement constitutes a lawful and valid signature, acceptance, and agreement, and shall be treated the same as if such were actually made using a physical, written signature. The parties further agree that no certification authority, or other third-party verification is necessary to validate their respective electronic signature. The parties additionally agree that this Agreement is accepted and agreed to when an electronic signature for each party has been affixed to this Agreement.

Customer consents to receive SEi invoices and statements by Electronic Delivery.

IN WITNESS WHEREOF, and intending to be legally bound, the parties have executed or caused this Agreement to be executed on the signing date unless otherwise agreed to in writing. Further, if the Customer is a corporation, the individual signing this Agreement on behalf of the Customer shall be personally liable as a surety for the financial obligation of the Customer.

SEi

Submitted By: Robb Walker
Approved By: _____
Date: _____

City Of Columbus

Signature: _____
Date: _____
Print Name: Matt Soukup
Title: _____
Email: Msoukup@Columbusne.Us

Terms & Conditions

- 1. Finance and Late Charges.** A three percent (3%) fee may be added to credit card payments over \$10,000. A finance charge of one and one-third (1 1/3%) percent per month sixteen (16%) percent per year will apply to all obligations not paid pursuant to the terms contained herein. Payment terms are NET 30 unless otherwise stated. Customer shall also pay to SEI an administrative fee (late charge) of five (5%) percent of any payment due hereunder received by SEI after the date on which such payment is due as liquidated damages and not as a penalty
- 2. Automatic Renewal.** This Agreement shall automatically renew under the same terms and conditions for successive periods equal to the initial period unless either party gives written notice to the other at least thirty (30) days prior to the expiration date of their intention to terminate this Agreement. In the event this renewal provision is not effective, this Agreement automatically renews from month to month unless either party gives at least thirty (30) days written notice to terminate at the expiration of any such term.
- 3. Right to Terminate.** Notwithstanding anything contained herein to the contrary, SEI may, in its sole discretion, terminate this Agreement, with or without cause and without any liability whatsoever, upon thirty (30) days notice to Customer. In the event such termination is without cause, SEI shall, upon the written request of Customer, refund any unearned service charges. If the termination is for a monetary default, Customer understand and agrees that SEI shall not release any data related to the System or any Services unless and until all amounts owed are paid in full.
- 4. Increase in Charges.** SEI shall have the right to increase periodic charges at any time or times after the expiration of one (1) year from the date of this Agreement upon giving Customer written notice thirty (30) days in advance of the effective date of such change. If Customer is unwilling to pay the increased charge, Customer must notify SEI in writing twenty (20) days prior to the otherwise effective date of the change that this Agreement will be terminated on the effective date of the charge. SEI may at its sole discretion rescind the charge at which time the previous term will be binding on the Customer to the full remaining term of this Agreement.
- 5. Breach by Customer.** In the event of any breach of this Agreement by Customer, without limiting the rights of SEI under this Agreement at law or equity, SEI shall be entitled to retain all prepayments received and Customer shall immediately pay to SEI (1) all payments then due and payable, (2) all charges for labor, material and equipment incurred by SEI due to such default based on a time and material basis at SEI's then prevailing charges, and (3) since actual damages upon Customer's breach are difficult to determine, Customer agrees to pay one hundred percent 100% of all payments which would be due hereunder for the unexpired term as liquidated damages and not as a penalty. Upon Customer's breach SEI shall have no further obligation to perform under this Agreement. In addition, if any suit or alternative dispute resolution proceeding is instituted and SEI is the substantially prevailing party by judgment, award, finding or settlement, Customer shall pay directly or reimburse SEI for all of its costs and expenses including, without limitation or example; consultants' and professionals' fees and costs including, without limitation or example; reasonable attorneys' fees and costs as allowed by law.
- 6. Right to Notice and Cure.** In the event of any breach of this Agreement by SEI, Customer agrees to provide written notice to SEI specifically identifying the nature of the breach and the provisions of this Agreement affected thereby, and to permit SEI to cure the breach within five (5) business days after receipt of the written notice or; if the breach cannot be reasonably cured within said period, to promptly commence to cure and diligently proceed until cured. If SEI cures any said breach as provided herein, this Agreement shall continue unabated and SEI shall not be liable to Customer for any loss, damage or expense arising out of or from, resulting from, related to, in connection with or as a consequence of any said breach.
- 7. Title; Suspension of Service; Shut-Down; Lock-Out.** If equipment is leased by or loaned to Customer, title to any such equipment shall at all times hereafter remain in SEI. Customer understands and agrees that SEI may, in its sole and absolute discretion, electronically lock out access to the control panel or alarm communicator (collectively, the "Panel") in order to limit access to the Panel to SEI only. Should Customer breach hereunder, or upon expiration or termination of this Agreement for any reason, or if the System excessively sends video images or data to SEI's monitoring facility as a result of any cause other than SEI's sole negligence, Customer authorizes SEI to: (1) suspend service; (2) shut down the Panel and/or the System; and (3) render some or all of the equipment incapable of sending a signal locally or communicating with any monitoring facility, and refuse to unlock the Panel. The exercise of such rights shall not be deemed a waiver of SEI's right to damages, and SEI shall have the right to enforce all other legal or equitable remedies or rights.
- 8. Installation; Service; Delays.** Customer acknowledges and agrees that SEI and Representatives have no knowledge of existing hidden pipes, wires or other like objects within walls, floors, ceilings and other concealed spaces, and it is Customer's obligation to advise SEI of such hidden objects, failing which SEI and Representatives are released for any damages, losses or expenses arising out of or from, in connection with, as a result of, related to or as a consequence of such hidden objects. SEI and Representatives make no representation of delivery and installation of equipment or commencement of services by any particular date. Any cost or expense incurred as a result of any such delay including, without limitation, any guard services required, shall be borne by and be the sole responsibility of the Customer.
- 9. Cross-Default.** In the event SEI and Customer are parties to any other agreement, Customer acknowledges and agrees that a default by Customer under this Agreement or any other agreement between the parties shall be deemed to be a default by Customer under all such agreements between the parties permitting SEI to exercise any or all of its rights under any or all of such agreements in the sole and absolute discretion of SEI.
- 10. SEI Duty Concerning Property of Others.** Customer agrees that SEI has no responsibility for the condition or operation of any equipment, device, or property of any sort belonging to Customer, the communications provider or others ("Property"). If SEI provides service to Property, Customer agrees that all relevant terms and conditions of this Agreement shall apply to all such service and Customer shall pay for such service on a time and material basis.
- 11. Additional Equipment or Service.** If, at any time after the date hereof, additional equipment or services are requested or authorized by Customer, all sales, leases, installation and services supplied by SEI shall be subject to the terms of this Agreement only, except that additional charges shall be made for such additional sales, leases, installation or services.
- 12. Customer's Duty to Pay for Increased Costs.** Notwithstanding anything to the contrary contained herein, if (a) any pass-through cost increase, or (b) any state or Federal statute or regulation, or (c) any trade union jurisdictional dispute results in SEI incurring any extra expense including, without limitation, paying higher compensation or wage rates to perform the installation and/or service, Customer hereby consents and authorizes SEI to incur such extra expense on behalf of and for the account of the Customer, and Customer shall pay SEI for all such costs incurred by SEI.
- 13. Communications Equipment and Services.** Customer understands and acknowledges that the System may transmit data to a monitoring facility or elsewhere using one or more forms of communication equipment or services, including, without limitation, a telephone network, broadband over power lines ("BPL"), voice (or data) over the Internet ("VOIP"), cable system or some form of wireless communications (e.g., cellular or another form of radio transmission). Some or all of these communications equipment or services may access or incorporate the Internet, electric company lines, a local area network or some other form of computer network to transmit or retrieve data. For data transmitted by a telephone network, there are various types of telephone line service including, without limitation, direct wire, derived channel, multiplex, DSL, T-1, ISDN and various other forms of service. For data transmitted by a wireless communications service or equipment, such services and equipment are probabilistic by their nature and can be affected or delayed by interference (e.g., ground interference), atmospheric conditions, static, transmission system operation, etc. Customer acknowledges that for data transmitted or received via DSL, BPL, VOIP or other broadband or internet-based communication service, the System's ability to transmit or receive data or SEI's monitoring facility's ability to receive, or understand, data will be dependent upon the electric company's lines, Internet, Internet providers or computer network, and/or any such installation of broadband or internet-based communication service may interfere with the telephone line-seizure feature of the System. All broadband or internet-based communication services should use a telephone number that is different than the telephone number used by the System. Accordingly, Customer understands, acknowledges and agrees that the System is not infallible and the transmission and receipt of data from the System, regardless of the communications equipment or type of service used, may be interrupted, circumvented or otherwise compromised.

Initials: _____



A. Transmission of Data, Video or Voice. Customer understands and agrees that the System including, without limitation, the communications equipment or service used in the System is not supervised. If the transmission medium for delivery of data ("Signals") video images or voice or other audio communications from your system to the monitoring facility is incompatible with the System or is inoperative, circumvented, compromised or interrupted by any natural or human cause including, without limitation, any sort of interference (e.g., ground interference or otherwise), loss of a telephone line or dial tone (either because the line is cut or otherwise), radio transmission interference, power line surges or outages, Internet or broadband problems and Internet or broadband provider problems, there will be no indication of such interruption at the monitoring facility. Further, if the communications equipment or service is incompatible, inoperative or interrupted, no Signal will be received at the monitoring facility. Customer may elect to use some form of redundant communication equipment or service (e.g., telephone combined with some form of wireless communication) or some other form of communication service or equipment as part of the System at additional cost. Further, Customer understands that (1) a video system enables SEI to record, store and review images of the Premises and the area outside of the Premises, (2) video and audio capability enables SEI to record, store and review oral communications from inside and outside of the Premises and (3) a two-way voice system enables SEI to listen-in to the Premises and to record, store and review such oral communications. Customer authorizes and consents to SEI viewing the Premises and the area outside the Premises and listening-in to the Premises and releases SEI for all claims, losses, damages, costs and expenses due to SEI viewing the Premises and the area outside of the Premises and listening-in to the Premises.

B. Monitoring Service. Monitoring service consists solely of monitoring service personnel ("Operator") communicating with First Responders or calling by telephone the telephone numbers supplied by the Customer in writing for First Responders and persons identified by Customer as Customer's emergency contacts ("Call List") within a reasonable period of time under the circumstances at the monitoring facility including, without limitation or example, (1) the priority of the data that has been previously identified in writing ("Listed Codes"), (2) when the Listed Code appears on the Operator's computer screen, or (3) when any voice communication or voice transmission is received from the Premises. No monitoring service shall be rendered for Signals received which are not Listed Codes or for voice communication which does not request assistance or for video transmission which does not clearly and conspicuously reveal the necessity for monitoring services. In the event a Signal is received at the monitoring facility which is not a Listed Code, Customer agrees that SEI's sole duty and obligation is for SEI to log the Signal. If "multiple zone delayed dispatch service" is requested, no monitoring service will be rendered for any burglar alarm System unless Listed Codes from more than one zone of the burglar alarm System are received within five (5) minutes of each other. When "no repeat dispatch service" is active, no monitoring service will be rendered for the same Listed Codes or zones received from the System within sixty (60) minutes after SEI has contacted Proper Authorities to report receipt of Listed Codes at the Premises. If the Premises is located in a jurisdiction requiring a personal verified onsite response ("Verified Response") prior to dispatching a First Responder, it is Customer's sole responsibility to engage a service to provide such Verified Response. All fees, costs and expenses in connection with Verified Response shall be borne by Customer only. Customer understands and agrees that First Responders may not be dispatched or respond to Customer's Premises after notice to First Responders of receipt of a burglar alarm signal or fire alarm signal by SEI unless there is independent confirmation of a burglary or fire at Customer's Premise, (e.g., an on-site witness' report that a point of entry exists or a fire exists). Notwithstanding anything contained herein to the contrary, (1) upon receipt of a Listed Code or video transmissions and prior to communicating electronically or by telephone to First Responders or the Call List, SEI may, in its sole and absolute discretion and without any liability, contact or attempt to contact the Premises or other telephone numbers, electronic mail, text messages or other similar means of communication at numbers or addresses provided by Customer in writing as frequently as SEI deems appropriate to verify the necessity to report the receipt of a Listed Code to First Responders or the Call List, and (2) upon receipt of an abort code or oral or electronic advice to disregard the receipt of the Listed Code or video images from any person at the Premises, Customer's representative or any of the personal contacts on the Call List, all of whom have Customer's authority and consent to direct SEI to disregard receipt of a Listed Code or video images, SEI may, in its sole and absolute discretion and without any liability, refrain from contacting First Responders, or the Call List, or advise anyone previously notified of a Listed Code or video images of receipt of an abort code, or oral, or electronic advice to disregard the receipt of the Listed Code or video images. SEI's efforts to notify First Responders or the Call List shall be satisfied by advice electronically or by telephone to any person answering the telephone at the telephone number(s) provided to SEI in writing or by leaving a message with a telephone answering service or any mechanical, electrical, electronic or other technology permitting the recordation of voice or data communications. Customer acknowledges and agrees that (3) all software, hardware, firmware, codes, Signals, audio and voice communications, video images, information and documentation arising out of or from, in connection with, related to, as a consequence of or resulting from this Agreement or the Services (collectively, the "IP Property") are the sole and exclusive property of SEI and Customer has no rights whatsoever in any of the IP Property, and (4) SEI shall have the right in its sole and absolute discretion to destroy, delete, erase, etc. (collectively "Destruction") the IP Property at any time without notice to Customer: provided that upon written request of Customer, received prior to the Destruction of the IP Property, to retain any specific IP Property, SEI shall use commercially reasonable efforts to store the specific IP Property as requested by Customer on the condition precedent that Customer pay all fees, costs and expenses related to any such request.

C. SEI as Agent; Revocation; Ratification; Retroactive Date. Customer hereby appoints SEI as its exclusive agent for the term of this Agreement to give direction to any monitoring facility which is a subcontractor of SEI, as if done by Customer concerning any and all matters arising out of, from, in connections with, or related to the performance of monitoring services. The authority granted to SEI under this Section shall continue to be binding upon Customer until revocation in writing from Customer shall have been actually received by SEI. No such notice shall affect anything done by (1) SEI in reliance hereon or pursuant hereto or (2) the monitoring facility pursuant to the request or demand of SEI prior to actual receipt by SEI of said written revocation. Customer hereby ratifies and confirms all prior and contemporaneous acts of (3) the monitoring facility pursuant to the request of SEI (4) SEI pursuant to this section which Customer acknowledges and agrees shall be and is deemed to be retroactive to the initial date SEI or the monitoring facility performed monitoring services on Customer's behalf.

D. Internet Services. If accepted, SEI hereby grants to Customer a non-exclusive, non-transferable license to use the SEI portal via the Internet to access, input, delete and modify information through the Internet. Except for Customer's 1) failure to keep confidential all information, passwords, etc., 2) use of the license or the information in any manner that negatively affects SEI, (3) use of the license or the information for any illegal purpose, or (4) violation of any applicable law, this license shall continue and be coextensive with the term of this Agreement or termination or suspension of the license by SEI. **SEI may immediately, and without notice, disable Customer's access to the Internet site and cancel all passwords or other access codes.**

E. Email Notice. In the event Customer elects to receive automatic email notice of certain System events, (e.g., the arming or disarming of the System), Customer acknowledges, understands and agrees that any such notice is conditioned on (1) receipt of the data at SEI's central station, (2) the proper operation of communication equipment, services, systems and networks including, without limitation, the Internet, and (3) any failure, malfunction or delay in processing or transmitting the data by SEI's equipment or software. SEI is hereby released from any liability arising out of or from, resulting from or in connection with the failure, malfunction or delay of any such notice for any reason, including SEI's or Representative's sole, joint or several negligence of any kind or degree.

F. Suspension of Service. Customer agrees that SEI's obligations hereunder are waived automatically without notice, and Customer releases SEI for all loss, damage and expense in the event of (1) a default or breach of this Agreement by Customer; (2) the monitoring facility, transmission medium between the System and the monitoring facility, or the System is destroyed, damaged, inoperable or malfunctions for any reason whatsoever; or (3) delays or interruption of Service(s) due in whole or in part, directly or indirectly, to: riots, strikes, lockouts, other labor disputes, civil unrest, terrorism, war (declared or undeclared), weather, natural phenomenon, acts of God, casualty, government orders, laws, rules or regulations, transportation, environmental conditions or any other reason beyond the reasonable control of SEI ("Force Majeure"), for the duration of such interruption of service, and Customer shall be entitled to reimbursement of the unearned charge paid for the period of interruption on request of Customer and this shall be the limit of SEI's liability. During any interruption of Services for any reason including, without limitation, Force Majeure: SEI has no duty, obligation or liability to supply Customer with alternate or substitute services.

Initials: _____



G. Video Systems. If the System records and/or transmits video images and/or audio, electronic or other forms of communication, Customer represents, warrants, covenants and agrees that Customer shall at all times (1) provide and maintain adequate power and lighting for all cameras audio devices or other video-related equipment as recommended by the manufacturer; (2) inform all persons who enter the Premises that their image and/or communications may be recorded and/or transmitted to others by video and/or audio equipment located on the Premises; (3) comply with all privacy rights and laws and not use or permit the use of video and/or audio equipment where or in circumstances any person may have a reasonable expectation of privacy; (4) use broadband connectivity exclusively to transmit video images and audio from any video system; (5) use the video and/or audio System for security surveillance and/or management services only; (6) not use the video and/or audio System for any criminal, illegal, or otherwise unlawful activity; and (7) obtain and keep in effect all permits or licenses required for the installation and operation of the video and/or audio System. Customer understands and agrees that (1) a video and/or audio System enables Customer and/or SEi to record, store and review images and/or communications of people in the Premises and outside of the Premises, and Customer hereby agrees, authorizes and consents to SEi recording, storing and reviewing video images and communications recorded and/or transmitted from the video and/or audio System at the Premises; (2) video system services are limited to the area of the Premises covered by the video system images and such coverages and/or images may be adversely affected by the camera angle, glare, lighting, contrast, etc., any of which may result in less than adequate images for the Operator to ascertain the necessity for video system services; (3) SEi is not liable for any delay or failure of notification due to in whole or in part to (a) any Force Majeure event including, without limitation or example, cellular provider transmission or network malfunctions, including overload of the cellular network, or (b) invalid email, text or other electronic addresses, and (4) any and all third party claims related to the video and/or audio system asserted against SEi shall be deemed to be subject to paragraph number 15 of this Agreement.

H. NO WARRANTIES. THERE ARE NO WARRANTIES, EXPRESS OR IMPLIED, WHICH EXTEND BEYOND THE DESCRIPTION ON THE FACE OR REVERSE HEREOF, INCLUDING ANY IMPLIED WARRANTY OF MERCHANTABILITY OR FITNESS FOR A PARTICULAR PURPOSE.

I. U.L. Certified Systems. In the event the System is U.L. certificated, Customer shall pay SEi's prevailing initial and renewal certificate fees. In the event the System is activated without objective physical evidence of the necessity for the activation and SEi dispatches an agent, Customer shall pay SEi's prevailing charge for dispatch of such agent. U.L. certificated systems satisfy the requirements of U.L. for the stated class and grade as of the date of installation. If in the future U.L. adopts new or different specifications of U.L. for the certificate issued, SEi agrees, upon receipt of written consent of Customer, to perform all services necessary to satisfy the new or different specifications of U.L. for the certificate issued, and Customer shall pay all costs thereof at SEi's then prevailing charges.

J. Right to Subcontract. SEi may subcontract for the provision of services under this Agreement. Customer acknowledges and agrees that the provision of this Agreement inure to the benefit of and are applicable to any subcontractors engaged by SEi to provide any service set forth herein to Customer, and bind customer to said subcontractor(s) with the same force and effect as they bind Customer to SEi. Any subcontractor and SEi are each independent contractors (not partners or joint ventures.)

K. Consent to Intercept, Record, Disclose and Use Contents of Communications. Customer, for itself and as the authorized agent of its owners, partners, members, officers, directors, invitees, guests, agents, representatives and employees (individually or collectively, "Any Person") hereby consents to SEi in the ordinary course of business intercepting, recording, retrieving, reviewing, copying, disclosing and using the contents of all telephone, video, wire, oral, electronic, Internet, broadband and other forms of transmission or communication to which Customer and/or Any Person and SEi are parties.

L. In the Event the System is activated. If the System is activated for any reason whatsoever, the Customer shall (1) pay without recourse, or (2) reimburse SEi for any fines, fees, costs, expenses and penalties assessed against Customer or SEi by any court or government agency.

14. Customer's Responsibility to Verify System Function. It is the Customer's sole responsibility to:

A. Confirmation of Equipment Compatibility. Confirm that the communications equipment, technology and services, which are not supplied by SEi, used to transmit data between the System and any monitoring facility are compatible with the System and any monitoring facility, especially when there are changes to such communications equipment, technology or services (e.g., starting, discontinuing, changing, adding or removing call waiting, a Centrex telephone system, answering machines, Derived Channel, DSL, T-1, BPL or VOIP service, or any telecommunications, radio, internet, satellite or other service or provider).

B. Testing of Equipment. Customer must test the System, communications equipment, technology and service periodically and whenever changes are made to communications equipment, technology or services for the System, Premises, data transmission or monitoring facility.

C. Acknowledgement of Potential Obsolescence. Customer understands, acknowledges and agrees that not all communications equipment, technology or services used to transmit data, video images and voice or other audio communications between the System and any monitoring facility are or will continue to be available from every telephone, radio, internet, satellite or other service provider (collectively, "Provider"). (1) In the event of any discontinuance, suspension, termination, modification or change (collectively, "Change") or any contemplated change as reasonably determined by SEi in connection with any communications equipment, technology, service or Provider, and there is a commercially reasonable alternative available in order to continue services under this Agreement, Customer hereby authorizes SEi to provide Customer with such alternative in SEi's sole and absolute discretion; (2) Customer shall be solely responsible to pay (or shall promptly reimburse SEi) for all costs of any Provider as well as charges by SEi to modify, substitute or replace any communications equipment, technology, software, service or Provider (at SEi's then prevailing rates on a time and material basis). Customer shall also be responsible for any increase in monthly charges under this Agreement for lease, service, monitoring, etc. in connection with, arising out of or from, as a result of or related to any discontinuance, suspension, termination, modification, change to or modification, substitution or replacement of the communications equipment, technology, software, service or Provider; (3) Any claimed inadequacy or failure of the System, the communications equipment, technology, software, service or Provider must be immediately reported to SEi or the Provider, as appropriate, for correction or repair service;

D. No Waiver of Breach. SEi does not waive breach of this Agreement unless specifically waived in writing by SEi. If SEi waives any breach by Customer, it shall not be construed as a waiver of any subsequent breach. SEi's rights hereunder are cumulative, and may be exercised concurrently or consecutively and include all remedies available whether or not referred to herein.

E. Duties of Parties When Equipment Required By Third Parties. Upon receipt of written notice from Customer, Customer's insurer, or other person having jurisdiction, SEi agrees to furnish and install all material and equipment required subject to availability, and Customer agrees to pay SEi for all costs on a time and material basis at SEi's then prevailing charges.

F. Key Service. If Customer provides SEi with keys, Customer agrees that SEi and Representatives are released for any loss, damage or expense to Customer due to the loss or theft of any keys.

15. DISCLAIMER/LIMITATION OF LIABILITY AND WARRANTY. CUSTOMER UNDERSTANDS AND AGREES THAT SEI IS NOT AN INSURER. IT IS THE INTENT OF THE PARTIES THAT INSURANCE COVERING LOSS, DAMAGE OR EXPENSE ARISING FROM, OR RELATED TO THIS AGREEMENT, SHALL BE OBTAINED AND MAINTAINED BY CUSTOMER. RECOVERY FOR LOSS, DAMAGE EXPENSE SHALL BE LIMITED TO CUSTOMER'S INSURANCE. CUSTOMER RELEASES SEI FROM LIABILITY FOR ALL LOSS, DAMAGE AND EXPENSE. SEI, AND EXCEPT AS SET FORTH HEREIN, MAKES NO GUARANTEE, REPRESENTATION OR WARRANTY INCLUDING, IMPLIED WARRANTY OF MERCHANTABILITY OR FITNESS FOR A PARTICULAR PURPOSE, EXCEPT AS MAY BE SPECIFICALLY PROVIDED HEREIN. CUSTOMER RELEASES SEI FROM ALL LIABILITY FOR ANY LOSS, DAMAGE OR EXPENSE WHICH MAY OCCUR PRIOR TO, CONTEMPORANEOUSLY WITH, OR SUBSEQUENT TO THE EXECUTION OF THIS AGREEMENT DUE TO IMPROPER OPERATION OR NON-OPERATION OF THE SYSTEM (INCLUDING, WITHOUT LIMITATION THE COMMUNICATIONS EQUIPMENT OR SERVICES NECESSARY TO TRANSMIT TO OR RECEIVE ANY VOICE, VIDEO OR DATA AT THE MONITORING FACILITY). SHOULD LIABILITY ARISE ON THE PART OF SEI FOR ECONOMIC LOSS, PERSONAL INJURY, OR PROPERTY DAMAGE (REAL OR PERSONAL) RESULTING FROM NEGLIGENCE BY SEI OR ITS REPRESENTATIVES WHICH OCCURRED PRIOR TO CONTEMPORANEOUSLY WITH, OR SUBSEQUENT TO THE EXECUTION OF THIS AGREEMENT, OR BREACH OF THIS AGREEMENT INCLUDING BUT NOT LIMITED TO ANY CLAIM BROUGHT IN PRODUCT OR STRICT LIABILITY, OR ANY CLAIM RELATED TO LOSS, THEFT OR UNAUTHORIZED USE OF ANY CONFIDENTIAL INFORMATION OR PERSONALLY IDENTIFIABLE INFORMATION OR PERSONAL HEALTH INFORMATION (AS DEFINED IN ANY PRIVACY LAW), OR ANY CLAIM FOR SUBROGATION, CONTRIBUTION OR INDEMNIFICATION, OR ANY OTHER CLAIM UNDER ANY OTHER THEORY OF LIABILITY, WHETHER IN CONTRACT, TORT OR EQUITY, INCLUDING, WITHOUT LIMITATION, ANY GENERAL, DIRECT, SPECIAL, INCIDENTAL, EXEMPLARY, PUNITIVE, STATUTORY OR CONSEQUENTIAL CUMULATIVE DAMAGES, IRRESPECTIVE OF CAUSE, SUCH LIABILITY SHALL BE LIMITED TO THE MAXIMUM SUM OF \$250.00 FOR SEI AND THIS LIABILITY SHALL BE EXCLUSIVE.

Initials: _____

A. RELEASE OF INSURED LOSSES. CUSTOMER HEREBY RELEASES SEI AND REPRESENTATIVES FOR ALL LOSSES, DAMAGES AND EXPENSES (1) COVERED BY CUSTOMER'S INSURANCE POLICIES, (2) POLICY DEDUCTIBLES, CO-PAY PERCENTAGE, OR RETAINED LIMITS, (3) IN EXCESS OF AMOUNTS PAID BY CUSTOMER'S INSURANCE, AND (4) DUE TO UNDER INSURANCE.

B. WAIVER OF SUBROGATION. AS AN INDUCEMENT TO SEI TO ENTER INTO THIS AGREEMENT, CUSTOMER REPRESENTS, WARRANTS AND COVENANTS THAT CUSTOMER'S INSURANCE COMPANIES SHALL NOT HAVE (1) ANY RIGHTS CREATED BY A LOAN AGREEMENT, LOAN RECEIPT, OR OTHER LIKE DOCUMENT OR PROCEDURE, OR (2) ANY RIGHT OF SUBROGATION, INDEMNIFICATION OR CONTRIBUTION AGAINST SEI OR REPRESENTATIVES.

(C) INDEMNIFICATION. CUSTOMER AGREES (1) THAT SEI SHALL HAVE THE RIGHT, BUT NOT THE OBLIGATION, TO DESIGNATE ITS ATTORNEYS TO CONTROL THE INVESTIGATION, DEFENSE AND SETTLEMENT OF ANY CLAIM OR SUIT AGAINST IT OR THEM. IF ANYONE OTHER THAN CUSTOMER, INCLUDING, WITHOUT LIMITATION: CUSTOMER'S INSURANCE COMPANY; ASKS SEI OR REPRESENTATIVES TO PAY FOR ANY LOSS, DAMAGE, OR EXPENSE (INCLUDING, WITHOUT LIMITATION: ECONOMIC LOSSES, PROPERTY DAMAGE, PERSONAL INJURY OR DEATH) DUE TO (1) BREACH OF CONTRACT OR WARRANTY, EXPRESS OR IMPLIED; (2) ACTIVE OR PASSIVE, SOLE, JOINT OR SEVERAL NEGLIGENCE OF ANY KIND OR DEGREE BY SEI OR REPRESENTATIVES; (3) FAILURE OR MALFUNCTION OF THE SYSTEM TRANSMISSION MEDIUM OR THE MONITORING FACILITY/FACILITIES; (4) RECORDING OF COMMUNICATIONS OR VIDEO SURVEILLANCE/RECORDING; (5) PRODUCT OR STRICT LIABILITY; (6) A CLAIM RELATED TO LOSS, THEFT OR UNAUTHORIZED USE OF ANY CONFIDENTIAL INFORMATION OR PERSONALLY IDENTIFIABLE INFORMATION OR PERSONAL HEALTH INFORMATION (AS DEFINED IN ANY PRIVACY LAW); (7) A CLAIM FOR SUBROGATION, INDEMNIFICATION OR CONTRIBUTION; OR (8) A CLAIM UNDER ANY OTHER LEGAL THEORY, CUSTOMER AGREES TO PAY (WITHOUT ANY CONDITION THAT SEI OR REPRESENTATIVES FIRST PAY) FOR ALL LOSSES, DAMAGES, COSTS AND EXPENSES INCLUDING, WITHOUT LIMITATION, ATTORNEY'S FEES, WHICH MAY BE ASSERTED AGAINST OR INCURRED BY SEI OR REPRESENTATIVES.

(NOTWITHSTANDING ANYTHING CONTAINED HEREIN TO THE CONTRARY, THIS PARAGRAPH SHALL NOT APPLY TO LOSSES AND DAMAGES OCCURRING WHILE SEI'S EMPLOYEE IS ON CUSTOMER'S PREMISES; PROVIDED, THAT SUCH LOSS AND DAMAGE IS CAUSED DIRECTLY AND SOLELY BY THE NEGLIGENCE OF SEI'S EMPLOYEE; PROVIDED, FURTHER, THAT COMPENSABLE DAMAGE UNDER THIS EXCEPTION SHALL BE LIMITED TO SEI'S INSURANCE POLICY COVERAGE AND THE AMOUNT OF PROCEEDS PAID OR RECEIVED FROM SEI'S INSURANCE POLICY APPLICABLE TO THE CLAIM, PROCEEDING OR ACTION.)

16. Inspection; Maintenance; Repair; Takeover Existing Systems.

A. Inspection of System and Services. If Customer has purchased inspection services, service consists of providing all labor necessary and testing equipment to inspect only the visible equipment of the System, pursuant to the terms hereof, for the sole purpose of determining if said visible equipment is operative. Inspection service shall be performed periodically or as otherwise agreed in writing, conditioned on Customer contacting SEI to schedule an appointment for such Service.

B. Periodic Maintenance. If Customer has purchased maintenance services, maintenance consists of providing all labor necessary to inspect the visible parts of the System and conditioned on Customer contacting SEI to schedule an appointment for such service, and to provide all necessary labor, material, parts and equipment to service the System at that time due to ordinary wear and tear only; excluding obsolete, end of useful life or degraded material, parts or equipment pursuant to the terms hereof. All other services shall be paid by Customer on a time and materials basis at SEI's then prevailing charges.

C. Service on Leased Systems. If the System is leased and covered by maintenance services, upon receipt of notice from customer of the necessity to service the System, SEI agrees, pursuant to the terms hereof, to provide all labor, material, parts and equipment to service the System due to ordinary wear and tear only, excluding obsolete, end of useful life or degraded materials, parts or equipment pursuant to the terms hereof. All other service shall be paid by Customer, on a time and material basis at SEI's then prevailing charges.

D. Repair. If Customer has purchased per call repair services, per call repair service consists of providing all necessary labor, material, parts and equipment to service the Customer's system, pursuant to the terms hereof, and Customer agrees to pay SEI on a time and material basis at SEI's then prevailing charges.

E. Limitation of Service Warranty. SEI makes no representation, promise, warranty or guarantee that there will be no interruptions of service or delay in performing service. SEI's sole obligation after receiving a service request is to dispatch a service employee to the Premises within a reasonable time after a service employee becomes available, during normal business hours excluding Saturdays, Sundays and holidays, after receipt of Customer's request to do so.

F. Service of Systems Exclusive to SEI. It is understood and agreed by the parties that all service to the System shall be performed by SEI only, but Customer agrees that SEI's duty to service the System is subject to the availability of the original part or equipment from the original manufacturer, and to the terms of this Agreement and conditioned upon Customer notifying SEI of the necessity for such service. Customer agrees to pay SEI's minimum service call charge in the event Customer does not provide unrestricted access when SEI attempts to provide service at the Premises. Further, Customer agrees that all repair, replacement or modification to the System shall be performed by SEI only. Unless this Agreement provides otherwise, all such service shall be paid by Customer on a time and material basis at SEI's then prevailing charges.

G. SEI Service to Existing Systems. If SEI takes over rendering services to an existing System, in whole or in part, SEI reserves the right, in its sole and absolute discretion, to terminate this Agreement at any time by giving ten (10) days written notice to Customer in the event SEI determines, in its sole and absolute discretion, that the system is not in good operating condition or in good working order, that the system will not operate properly with the services, that there have been excessive activations of the System, that the Customer has abused the System or that the number of problems or cost of service has been or may become excessive, and upon termination by SEI, Customer shall be entitled to reimbursement of the pro-rata cost paid for the then current period on request of Customer and this shall be the limit of SEI's liability.

H. Remote Programming Service. Remote programming services consists of inputting, modifying, deleting and using electronic data concerning operation of the System through electronic communication between the System and SEI's office or monitoring facility. Customer hereby consents to SEI's performance of all such services pursuant to SEI's then prevailing charges for such services.

17. Applicable Law, Choice of Forum.

A. Contractual Limitation of Actions. All claims, actions or proceedings; legal or equitable; against SEI or Representatives must be commenced in court within one (1) year after the cause of action has accrued, without judicial extension time, or said claim, action or proceeding is barred. Time is of the essence of this paragraph.

B. Jurisdiction, Venue and Waiver of Jury Trial. Each party hereby irrevocably agrees that any suit, action or other legal proceeding ("Suit") arising out of or from, in connection with or as a result of this Agreement shall be brought exclusively in the State District Court in Douglas County, Nebraska, without reference to its conflicts of law rules. The interpretation of this Agreement shall not be construed against the drafter. Each party consents to the exclusive jurisdiction and venue of each such court in any such Suit and waives any objection that it may have to jurisdiction or venue of any such Suit. Each party consents to service of process in accordance with the notice provisions of this Agreement. Each party hereby waives any right to trial by jury in any Suit, action or other legal proceeding brought by either party.

C. Assignability of Agreement. This Agreement is not assignable by Customer except upon the written consent of SEI, which shall be in SEI's sole and absolute discretion. This Agreement or any portion thereof is assignable by SEI in its sole and absolute discretion.

D. Credit Investigation Report. Customer authorizes and consents to credit investigations and reports by SEI and any other person or entity that provides financing to SEI or to whom this Agreement may be assigned.

18. LIMITED WARRANTY (ONLY IF SYSTEM SOLD TO CUSTOMER)

A. LIMITED WARRANTY OF MATERIAL. SEI HEREBY WARRANTS TO CUSTOMER THAT ORIGINALLY PURCHASED THE SYSTEM ALONE ONLY THAT ALL OF THE MATERIAL IS INSTALLED IN A GOOD AND WORKMAN-LIKE MANNER. IN THE EVENT THAT ANY PART, EXCEPT FOR WIRING, BATTERIES AND OTHER CONSUMABLE PARTS SHALL BECOME DEFECTIVE WITHIN ONE (1) YEAR FROM THE DATE OF THE ORIGINAL INVOICE FOR THIS INSTALLATION, OR FOR A TERM EQUAL TO THAT PROVIDED BY THE ORIGINAL EQUIPMENT MANUFACTURER, WHICHEVER IS LESS, SEI SHALL, AT ITS SOLE ELECTION, REPLACE OR REPAIR THE DEFECTIVE PART WITHOUT CHARGE TO CUSTOMER. ANY REPLACEMENT PART SHALL REMAIN UNDER WARRANTY FOR THE REMAINDER OF THE ORIGINAL WARRANTY PERIOD. THIS WARRANTY IS NOT ASSIGNABLE.

Initials: _____

B. DISCOVERY OF DEFECT. IF CUSTOMER SHALL DISCOVER A DEFECT IN THE PRODUCTS SUPPLIED UNDER THIS AGREEMENT, CUSTOMER SHOULD IMMEDIATELY CONTACT SEI IN WRITING OR BY TELEPHONE, AT THE ADDRESS AND TELEPHONE NUMBER SET FORTH ABOVE, AND FULLY DESCRIBE THE NATURE OF THE DEFECT SO THAT REPAIR SERVICE MAY BE RENDERED.

C. LIMITED EXPRESS WARRANTIES. EXCEPT AS SET FORTH IN PARAGRAPH A, SEI AND REPRESENTATIVES MAKE NO EXPRESS WARRANTIES AS TO ANY MATTER WHATSOEVER, INCLUDING, AND WITHOUT LIMITATION, THE CONDITION OF THE EQUIPMENT, ITS MERCHANTABILITY, OR ITS FITNESS FOR ANY PARTICULAR PURPOSE; ALL OTHER WARRANTIES ARE SPECIFICALLY EXCLUDED. THIS WARRANTY DOES NOT COVER ANY SOFTWARE, ON-SITE PROGRAMMING OR REPROGRAMMING OF THE SYSTEM, DAMAGE TO MATERIAL OR EQUIPMENT CAUSED BY ACCIDENT, VANDALISM, WAR, DECLARED OR UNDECLARED, CIVIL UNREST, TERRORISM OR OTHER VIOLENCE, CUSTOMER NEGLIGENCE, FLOOD, WATER, LIGHTNING, FIRE, INTRUSION, ABUSE, MISUSE, ACT OF GOD, STRIKE, LOCKOUT OR OTHER LABOR DISPUTE; ANY LAW, ORDER OR OTHER REQUIREMENT OF ANY GOVERNMENTAL AGENCY OR OTHER AUTHORITY, ANY CASUALTY, INCLUDING: ELECTRICITY, ATTEMPTED UNAUTHORIZED REPAIR SERVICE, MODIFICATION OR IMPROPER INSTALLATION BY ANYONE OTHER THAN SEI, OR ANY OTHER CAUSE OTHER THAN ORDINARY WEAR AND TEAR. SEI SHALL NOT BE LIABLE FOR ANY GENERAL, DIRECT, SPECIAL, EXEMPLARY, PUNITIVE, STATUTORY, MULTIPLE, INCIDENTAL OR CONSEQUENTIAL DAMAGES. CUSTOMER ACKNOWLEDGES THAT ANY AFFIRMATION OF FACT OR PROMISE MADE BY SEI SHALL NOT BE DEEMED TO CREATE AN EXPRESS WARRANTY; THAT SEI DOES NOT MAKE ANY REPRESENTATION OR WARRANTY, INCLUDING ANY IMPLIED WARRANTY OF MERCHANTABILITY OR FITNESS THAT THE SYSTEM OR SERVICE SUPPLIED MAY NOT BE COMPROMISED, CIRCUMVENTED OR THE SYSTEM OR SERVICES WILL IN ALL CASES PROVIDE THE SIGNALING, MONITORING AND RESPONSE FOR WHICH IT WAS INTENDED; THAT CUSTOMER IS NOT RELYING ON SEI'S SKILL OR JUDGEMENT IN SELECTING OR FURNISHING A SYSTEM SUITABLE FOR ANY PARTICULAR PURPOSE; THAT THERE ARE NO EXPRESS WARRANTIES WHICH EXTEND BEYOND THOSE ON THE FACE OF THE AGREEMENT HEREOF, OR HEREIN, AND THAT ALL IMPLIED WARRANTIES, IF ANY, COINCIDE WITH THE DURATION OF THIS WARRANTY.

19. Integrated Agreement; Valid Agreement; Modifications. This instrument contains the entire Agreement between the parties hereto with respect to the transactions described herein and supersedes all previous and contemporaneous negotiations, commitments, contracts, express or implied, warranties, express or implied, statements and representations, whether written or oral, pertaining thereto, all of which shall be deemed merged into this Agreement. (a) Neither party has authority to make or claim any representation, term, promise, condition, statement, warranty, or inducement which is not expressed herein. Each party represents that it/he/she is not relying any inducement in signing this Agreement which is not expressed in this Agreement. (b) Should any provision hereof (or portion thereof), or its application to any circumstances, be held illegal, invalid or unenforceable, to any extent, the validity and enforceability of the remainder of the provision and this instrument, or of such provisions as applied to any other circumstances shall not be affected thereby, and shall continue in full force and effect as valid, binding and subsisting; provided, however, in the event either the "Disclaimer/ Limitation of Liability" or "Indemnification" sections or any portion of each is held by a court to be invalid or unenforceable, SEI shall have the right to terminate this Agreement without any liability upon thirty (30) days prior written notice to Customer. If any provision or portion thereof is stricken, then such stricken provision or portion thereof shall be replaced, to the extent possible, with a legal, valid and enforceable provision that is as similar in tenor to the stricken provision or portion thereof as is legally possible. All changes or amendments to this Agreement must be in writing and signed by all parties to be binding on the parties.

20. Prior Agreements with Others. Customer represents and warrants that (a) his/her/their cancellation or termination of any contract, or (b) execution of this Agreement does not breach and will not breach any contract with or obligation to any other person. Customer agrees to protect, defend, indemnify and hold harmless SEI and Representatives, from and against, and pay (without any condition that SEI or Representative first pay) for all claims, demands, suits, liabilities, losses, damages, judgments, costs and expenses including, without limitation: attorney's fees and court costs arising out of or from, in connection with, as a result of, related to or as a consequence of Customer's breach of this representation and warranty as allowed by law.

21. Environmental Considerations. Customer acknowledges and agrees that any duty or obligation of SEI or Representatives under this Agreement, at law or in equity is subject to and conditioned upon, among other things, the Premises not containing or being affected in any manner whatsoever by any public or private nuisance, ultra-hazardous or dangerous activity or any hazardous substance ("Environmental Considerations") or the violation of any applicable local, state or federal statute, ordinance, rule, regulation, order or court order arising out of or from, in connection with, resulting from, related to or as a consequence of Environmental Considerations. In the event the Premises contain or are affected by Environmental Considerations, SEI may elect, in its sole and absolute discretion and without any liability whatsoever, to (a) terminate this Agreement pursuant to the paragraph titled "Breach by Customer", or (b) affirm this Agreement. If SEI affirms this Agreement, Customer shall (a) immediately remove all Environmental Considerations at Customer's sole cost and expense and (b) pay SEI for all increased costs to perform this Agreement.

22. Electronic Media. Customer authorizes SEI to scan, image or otherwise convert this Agreement and any ancillary documents into an electronic format of any nature and to destroy all such written documents. Customer agrees that a copy of this Agreement or other ancillary document produced from such electronic format is legally equivalent to the original for any and all purposes, including litigation or arbitration.

23. Execution in Counterparts and by Facsimile or Electronically. This Agreement may be executed in any number of counterparts, any one of which need not contain the signature of more than one party, but all of which shall together constitute one and the same instrument. The parties agree that this Agreement and the signatures affixed hereto may be transmitted and delivered by facsimile or electronically and that all such signatures and this Agreement transmitted or delivered by facsimile or electronically shall be deemed to be originals for all purposes and given the same legal force and effect as the original Agreement and original signatures, including litigation and arbitration.

24. Authorization. SEI and Customer each represent and warrant to the other party that (a) the execution, delivery and performance of this Agreement have been duly authorized by all necessary entity action, and (b) this Agreement constitutes a valid and binding obligation as to it, enforceable against it in accordance with its terms.

25. Consent to Call Customer and Call List. Customer for him/her/itself and as the authorized agent of Customer's employees and each person on the Call List from time-to-time, consents to SEI (a) calling each such person's cell phone or mobile device; (b) using automatic dialers; and (c) using a technology known as "robocalling" (unless such person notifies SEI that he/she opts out of this clause).

26. Paragraph Headings. The paragraph titles used herein are for convenience of the parties only and shall not be considered in construing the provisions of this Agreement.

27. Applications. If Customer has subscribed to an application (an "App"), Customer understands and agrees that (a) the App was developed by a third-party App Developer, not SEI; (b) as a condition of downloading and using the App Customer must first agree to and continue to comply with the terms of an end-user license agreement ("EULA"); (c) the EULA is between Customer and the App Developer only; (d) the App Developer, not SEI, is solely responsible for the App; (e) SEI disclaims any and all warranties in connection with the App and shall not be liable for any damage, loss, cost or expense incurred by Customer and related to the App or Customer's use of the App; and (f) as between Customer and SEI; SEI is a third-party beneficiary of the EULA.

Initials: _____

13.B. Proposed fees for Aquatics and Parks and Recreation for Fiscal Year 2023-2024. (Board of Parks Commissioners recommends approval.)



City Clerk's Office
(402) 562-4224
Email: cclerk@columbusne.us
www.columbusne.us

DATE: August 31, 2023
FROM: Janelle Kline, City Clerk
TO: Tara Vasicek, City Administrator
RE: Proposed Fees for Aquatics and Parks & Recreation for FY 2023-2024

RECOMMENDATION:

I recommend the proposed fees for Aquatics and Parks & Recreation for Fiscal Year 2023-2024 be included with the Schedule of Fees to be presented for adoption at the September 18th city council meeting.

DISCUSSION:

Attached is a red-line copy of proposed fees for Aquatics and Parks & Recreation that were omitted from the fee schedule presented to the Committee of the Whole on August 21, 2023. The proposed fees were approved by the Board of Parks Commissioners at their June 6, 2023, meeting (see attached portion of Park Board minutes).

SIGNATURE:

By: 

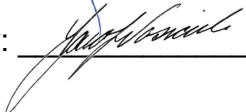
Approved By: 



BOARD OF PARKS COMMISSIONERS

MAY 2, 2023

A regular meeting of the Board of Parks Commissioners of the City of Columbus, Nebraska, was convened in open and public session on May 2, 2023, at 12 p.m. in the Council Chambers, 1369 25 Avenue, Columbus, Nebraska.

Notice of this meeting was given in advance thereof by publication in the Columbus Telegram on April 26, 2023, with a copy of the proof of publication being on file in the office of the city clerk. Availability of the agenda was communicated in the advance notice to the members of the Board of Parks Commissioners. All proceedings hereafter shown were taken while the convened meeting was open to the public.

1. **STATEMENT OF COMPLIANCE WITH OPEN MEETINGS ACT.** Chair Hansen announced that a copy of the Open Meetings Act is posted in the meeting room. Present were Members Jon Brezenski, Robbin Cutsor, Jack Gutierrez, Brad Hansen, Sandra Jochens, Nick Larson, Gary Puetz, Bruce Schmidt, and Lynn Sjuts. City staff members included Public Property Director Doug Moore, Park Superintendent Tom Ek, Park and Recreation Manager Betsy Eckhardt, Park and Recreation Coordinator Sydney Winger, Aquatics Park and Recreation Coordinator Joe Krepel, Public Communications Manager Matt Lindberg, Golf Course Superintendent Shawn Riedmiller, and Account Clerk II/Records Clerk II Linda Nickeson.
2. **MINUTES OF APRIL 4, 2023, MEETING.** The minutes were approved as presented with a motion by Schmidt and a second by Sjuts. Brezenski, Cutsor, Gutierrez, Hansen, Jochens, Larson, Puetz, Schmidt, and Sjuts voted "Aye" and none voted "Nay".
3. **REQUEST OF AMERICAN LEGION HARTMAN POST #84 TO CONSTRUCT A MEMORIAL WALL AT PAWNEE PARK BASEBALL FIELD.** Ken Robinson, American Legion Hartman Post #84 Athletic Committee Chairman, stated that the family of Bill Jackson presented the organization with a \$2,500 memorial donation designated for Pawnee Park baseball field. He explained detailed plans to construct a memorial wall at the facility that would include all branches of military service along with an image of and special tribute to Bill Jackson. The motion to approve the veteran memorial wall as presented was made by Larson and seconded by Jochens. Brezenski, Cutsor, Gutierrez, Hansen, Jochens, Larson, Puetz, Schmidt, and Sjuts voted "Aye" and none voted "Nay".
4. **AQUATICS AND PARKS AND RECREATION FEES.** Moore stated that Mayor Bulkley requested staff look into the possibility of establishing non-resident fees for aquatic and park facility usage; therefore, approval of the proposed fees for the 2023-2024 budget year will be postponed until the June meeting. Hansen requested that a comparison of fees over the past two years be available at the June meeting as well.

BOARD OF PARKS COMMISSIONERS

JUNE 6, 2023

A regular meeting of the Board of Parks Commissioners of the City of Columbus, Nebraska, was convened in open and public session on June 6, 2023, at 12 p.m. in the Council Chambers, 1369 25 Avenue, Columbus, Nebraska.

Notice of this meeting was given in advance thereof by publication in the Columbus Telegram on May 31, 2023, with a copy of the proof of publication being on file in the office of the city clerk. Availability of the agenda was communicated in the advance notice to the members of the Board of Parks Commissioners. All proceedings hereafter shown were taken while the convened meeting was open to the public.

1. **STATEMENT OF COMPLIANCE WITH OPEN MEETINGS ACT.** Chair Hansen announced that a copy of the Open Meetings Act is posted in the meeting room. Present were Members Jon Brezenski, Jack Gutierrez, Brad Hansen, Sandra Jochens, Nick Larson, Gary Puetz, Bruce Schmidt, and Lynn Sjuts. One seat vacant. City staff members included Public Property Director Doug Moore, Park Superintendent Tom Ek, Park and Recreation Manager Betsy Eckhardt, Public Communications Manager Matt Lindberg, and Account Clerk II/Records Clerk II Linda Nickeson.
2. **MINUTES OF MAY 2, 2023, MEETING.** The minutes were approved as presented with a motion by Gutierrez and a second by Jochens. Brezenski, Gutierrez, Hansen, Jochens, Larson, Puetz, Schmidt, and Sjuts voted "Aye" and none voted "Nay". One seat vacant.
3. **AQUATICS AND PARKS AND RECREATION FEES FOR 2023-2024 BUDGET.** Moore explained that after researching the possibility of incorporating a non-resident fee, staff feels it would be best to hold off until the various parks and recreation program changes have been well established. Eckhardt explained the cost difference between Pawnee Plunge passes and Grand Island passes, pointing out the significant population difference and the fact that Grand Island collects a restaurant tax to supplement their parks and recreation revenues. Discussion was held regarding the cost of Memorial Stadium for events where both admissions are charged and concessions are sold in relation to the cost of events where only one or the other is utilized, resulting in a decision to reduce the fee from \$650 to \$525. A recommendation to approve the proposed Aquatics and Parks and Recreation fees with an amendment to reduce the cost of Memorial Stadium use where both admissions are charged and concessions are sold from \$650 to \$525 was approved with a motion by Larson and second by Schmidt. Brezenski, Gutierrez, Hansen, Jochens, Larson, Puetz, Schmidt, and Sjuts voted "Aye" and none voted "Nay". One seat vacant.
4. **CHANGE DATE OF THE JULY 2023 MEETING TO 12 P.M., MONDAY, JULY 10, 2023, DUE TO JULY 4TH HOLIDAY.** The July 2023 meeting was changed to 12 p.m., Monday, July 10th with a motion by Brezenski and second by

AQUATICS

The Parks and Recreation Director shall establish recreation program fees for miscellaneous sales, programming, special events, and promotion.

Passholders may receive a discounted price for some programs. The discount will reflect that the passholder is already paying for facility usage and the fee will be for the cost of the program only.

Program fees are non-refundable

AQUATIC CENTER

Daily Admission

Individual \$ 5

Annual Membership Pass

Individual \$125

Group (Maximum of 6) \$600

Monthly Pass

Individual \$ 35

Combo Membership Pass (Aquatic Center & Pawnee Plunge)

Individual \$175

Household Group up to 6 people (Must reside in the same household) \$600

Each addl person in same household (can include one caregiver) \$ 90

Non-Household Group (Maximum of 6) \$800

Admission Punch Cards

50 Punches \$ 100

25 Punches \$ 75

10 Punches \$ 35

5 Punches \$ 20

Group Swimming Lesson

Parent/Child \$ 45

Preschool \$ 45

Grades 1 through 6 \$ 60

Private Swimming Lesson

1 Lesson Package \$ 35

5 Lesson Package \$175

10 Lesson Package \$300

Swimming lessons are non-refundable.

Locker Rentals – Annual	\$ 50
Aquatic Therapy *Requires agreement.	\$75 per 15 minutes
Facility Rental:	
Private Facility Rental	\$100/hr.
Party Room Rental (baptisms, meetings, family reunions, etc.) (swimmers will pay daily admission or use pass)	\$ 60
Birthday Party Packages:	
Cost includes 20 guest admissions (\$5/additional guest), full access to party room including: tables, chairs, refrigerator and more, t-shirt for the Birthday Child, and additional staff.	
Non-Private Party: Normal Operating Hours	
Saturday 12pm (Set Up), 1pm-4pm Party	
Passholder	\$100
Non-Passholder	\$125
Private Party: Outside Normal Operating Hours	
Friday: 4pm (Set Up) 5pm-8pm Party	
Saturday: 4pm (Set Up) 5pm-8pm Party	
Sunday 12pm (Set Up) 1pm-4pm Party	
Passholder	\$125
Non-Passholder	\$150
Concessionaire/Vending	
Daily Fee	\$ 16
Lifeguard Class	
Full Class (5 student minimum)	
Employee	\$ 70
Non-Employee	Actual program cost plus administrative fees
Review Class – includes CPR review (5 student minimum)	
Employee	\$ 40
Non-Employee	Actual program cost plus administrative fees
CPR Class	
Full Class (5 student minimum)	
Employee	\$ 30
Non-Employee	Actual program cost plus administrative fees

Review Class (5 student minimum)

Employee

\$ 15

Non-Employee

Actual program cost plus administrative fees

Class Materials

Actual cost of materials

Manual	\$ 50
Mask (first mask is included in the full Water Park class)	\$ 25
Certification Card	\$ 5

Staff Uniforms

Tankini	\$ 25
Female Guard Suit	\$ 20
Female Non-Guard Suit	\$ 20
Male Swim Trunks	\$ 20
Aquatic Center T-Shirt	\$ 5
Lanyard	\$ 1
Whistle	\$ 1

PAWNEE PLUNGE WATER PARK

Daily Admission

3 yrs. & Under	Free
4 yrs. & Up	\$ 10
(Incl both open sessions: 12 Noon – 5 p.m. and 6:30 p.m.-8:30 p.m.)	
10 Person Group	\$ 70
5 Person Group	\$ 40
Non-Swimmer (not swimming and not dressed to swim)	\$ 3
Evenings 6:30 p.m. – 8:30 p.m. Monday through Thursday	\$ 4

Fitness

Passholder	No charge
Non-passholder	\$ 5

Flow Rider Bracelet

(In addition to daily/season/combo pass)

\$ 3

Season Pass

Individual	\$125
Household Group up to 6 people (Must reside in same household)	\$400
Each addl person in same household (can include one caregiver)	\$ 60
Non-Household Group (Maximum of 6)	\$600

Combo Membership Pass (Aquatic Center & Pawnee Plunge)

Individual	\$175
Household Group up to 6 people (Must reside in the same household)	\$600
Each addl person in same household (can include one caregiver)	\$ 90
Non-Household Group (Maximum of 6)	\$800

Admission Punch Cards

50 Punches	\$200
25 Punches	\$125

Group Swimming Lesson

Parent/Child	\$ 45
Preschool	\$ 45
Grades 1 through 6	\$ 60

Private Swimming Lesson

1 Lesson Package	\$ 35
5 Lesson Package	\$175
10 Lesson Package	\$300

Swimming lessons are non-refundable.

Facility Rental

Public Hours are 12:00 p.m. – 8:00 p.m.

Exclusive Use – Before or After Public Hours \$500/hr
(Includes 1 supervisor, 1 office personnel, 14 lifeguards, 4 slides)

Reservation required with deposit of \$500. Deposit will be applied toward total rate. Cancellations must be received twenty-four hours in advance or deposit will not be refunded.

Flow Rider exclusive use – Before or After Public Hours \$ 75/hr
(Includes 1 supervisor, 1 office personnel, 1 lifeguard)

Lap Pool exclusive use – Before or After Public Hours \$150/hr
(Includes 1 supervisor, 1 office personnel, 3 lifeguards)

Party Room \$ 60
Monday - Thursday, 12:30 p.m. – 4 p.m.
Friday – Sunday, 12 p.m. – 3:30 p.m. or 3:30 p.m. – 7 p.m.

Staff Uniforms

Tankini	\$ 25
Female Guard Suit	\$ 20
Female Non-Guard Suit	\$ 20
Male Swim Trunks	\$ 20
Pawnee Plunge T-Shirt	\$ 5
Lanyard	\$ 1
Whistle	\$ 1

PARKS AND RECREATION

All fees are non-refundable.

Athletic Field Rentals:

Recreation Leagues-Baseball/Softball	\$15/Field/Day Youth \$35/Field/Day Adult
Organized Leagues (Clubs) Baseball/Softball	\$55/Field/Day Youth/Adult
Tournaments-Baseball/Softball	\$55/Field/Day Youth/Adult
Recreation Practice-Baseball/Softball	No Charge Youth/Adult BUT must be scheduled through Parks and Rec or not permitted
All outside Columbus community games	\$155

Due to proximity of the track and ball field, no baseball games shall be scheduled at the same time a track meet is in progress. Baseball practice may take place, but limited to a practice where balls do not land in the track and football field area.

Bleachers:

Bleacher rental (five row only) for special events held in a city park	\$93/bleacher/event. Contingent upon availability. City will deliver and pick up.
---	--

Clinics:

Non-Profit organization (sponsor is a local organization)	\$60 (includes refuse disposal)
Private organization (profits to be used for individual benefit.)	\$215/day \$240/day, if lights are used

Commercial Nature:

For anything of a commercial nature in any park where electricity is used, a \$10 fee will be assessed. If additional cleanup is required, an additional \$50 fee will be assessed.

Cleanup for Columbus Days event in Frankfort Square	\$190/day
---	-----------

Concessionaire:	\$20/day \$35/month
------------------------	------------------------

Park Board approval required for those wishing to sell goods and services on property under Park Board jurisdiction.

Concession Stand Rentals:

Armory, Gerrard, Centennial, Pawnee Park Baseball, Bradshaw, and Wilderness

Non-profit organization \$130/season, plus cleanup

Private organization \$295/season, plus cleanup

Disc Golf:

Tournaments \$35

League Play \$35
Once per week/12 consecutive week maximum

Football: (Pawnee and Bradshaw Parks)

Scotus & Columbus High Schools \$800/varsity game

JV, Junior High, Freshman, Middle School
and Soap Scrimmages (under lights) \$400/game

JV, Junior High, Freshman, and Middle School (no lights) \$200/game

All non-local teams \$1,000/game

Horseshoe:

Electricity \$100/season

Tournaments \$65/tournament

Softball:

High School/College \$70 for refuse disposal
Electricity is 35% of actual usage for each season.

Tennis/Pickleball:

High School \$500/school year

Pawnee Park \$26/court/day
\$35 for 6 courts, 2 hours/day
\$100 for 6 courts/day

Gerrard Park \$26/court/day

Tennis Association Electricity Fee \$275/season

Track:

Practice per season, per school \$335

(Columbus and Scotus High Schools,
Columbus Middle School & Scotus Jr. High)

Invites and Relays	\$195/meet
Districts or Conference	\$270/meet \$395/meet (not involving Columbus schools)
Dual/Triangular Meets	\$70/meet
Electronic Timing System	\$210/meet
Special Olympics	\$50

No track practice can be held when a scheduled track meet is in progress. Due to proximity of the track and ball field, no baseball games shall be scheduled at the same time a track meet is in progress. Baseball practice may take place, but limited to a practice where balls do not land anywhere in the track and football field area.

Cost for items such as hurdles, jumping standards, jumping pits, and pole vault boxes will be split between the City, Columbus High School, and Scotus High School.

PROGRAMS:

The Parks and Recreation Director shall establish recreation program fees for miscellaneous sales, programming, special events, and promotion.

Program fees are non-refundable.

Shelter Reservations:

Glur Park Shelter	\$50/day
Pawnee Park West Shelter	\$25/table
Pawnee Park East Shelter	\$50/day

Payable at time reservation is made. No refunds.

Bark Park Reservation \$35/day

Stadium Reservations:

\$150 plus cleanup per event where no admission is charged or concession used. Park crew wages will be added to the \$150 fee for cleanup.

\$225/event where admission is charged.

\$300/event where concession is used.

~~\$650~~ \$525/event where admission and concession are used.

~~\$25~~ 50/hour for video board usage

Marching Band Festival \$800

Wedding Reservation ~~\$36~~ \$35 (to match bark park)

Condition of area for wedding is "as is".

**All events requiring extra cleanup
(garbage receptacles emptied only)** \$70/day

13.C. Comments from mayor and city council members.

14. RESOLUTIONS

14.A. Resolution No. R23-118 approving Change Order No. 2 with B-D Construction, Inc. in the amount of \$35,871.09 for project closeout mechanical, electrical, structure, information technology, and apparatus bay revisions and additions for Charlie Louis Fire Station addition and renovation project.

RESOLUTION NO R23-118

A RESOLUTION OF THE MAYOR AND COUNCIL OF THE CITY OF COLUMBUS, NEBRASKA, APPROVING CHANGE ORDER NO. 2 WITH BD CONSTRUCTION, INC. FOR CHANGE ORDER PROPOSALS 003, 005, 006, 009, 010, 012, 013, 015, 016, 017, 018, 019 AND 020 IN THE COMBINED AMOUNT OF \$35,871.09, FOR CHARLIE LOUIS FIRE STATION ADDITION AND RENOVATION PROJECT.

WHEREAS, Resolution No. R22-48 awarded the construction contract to BD Construction, Inc.; and

WHEREAS, Resolution No. R22-133 approved Change Order No. 1; and

WHEREAS, modification or addition for IT systems (003, 005, 006, and 020); structural, mechanical, and electrical revisions (009, 010, 012, 013, 015, 016, and 018); and apparatus bay additions (017 and 019) are required and the combined additional cost modify the awarded amount; and

WHEREAS, city staff and representatives of BD Construction, Inc. and WSKF Architects discussed said modifications; and

WHEREAS, BD Construction, Inc. has concurred on the proposed modifications as identified in Change Order No. 2.

NOW, THEREFORE, BE IT RESOLVED BY THE MAYOR AND COUNCIL OF THE CITY OF COLUMBUS, NEBRASKA, that Change Order No. 2 with BD Construction, Inc. for Change Order Proposals 003, 005, 06, 009, 010, 012, 013, 015, 016, 017, 018, 019, and 020 in the combined amount of \$35,871.09, is approved and the mayor is authorized to sign on behalf of the City of Columbus.

INTRODUCED BY COUNCIL MEMBER _____

PASSED AND ADOPTED THIS ____ DAY OF _____, 2023.

MAYOR

ATTEST:

CITY CLERK

APPROVED AS TO FORM:

CITY ATTORNEY

The City of **Columbus**

MEMORANDUM

DATE: August 30, 2023
FROM : Richard Bogus, P.E. City Engineer
TO: Tara Vasicek, City Administrator
RE: Charlie Louis Fire Station Addition and Renovation Project – End of Project Closeout Change Order No. 2

RECOMMENDATION:

I recommend approval of the end of project closeout Change Order No. 2 with BD Construction, Inc. for Change Order Proposals (COP) 003, 005, 006, 009, 010, 012, 013, 015, 016, 017, 018, 019, and 020 in the combined amount of \$35,871.09 for the Charlie Louis Fire Station Addition and Renovation project.

DISCUSSION:

The end of project closeout change order includes the following:

COPs 003, 005, 006 and 020: IT required revisions or additions, such as, conduits and termination hardware

COPs 009, 010, 012, 013, 015, 016 and 018: Structural, mechanical, or electrical revisions required, such as casework transition, plumbing connection, sewer tie-in paving, heater panelboard revision, additional GFI receptacles, additional steel porch hardware, and upgraded light fixtures.

COPs 017 and 019: Apparatus bay additions required, such as, hose tower painting and hose reels.

The project did not have contingency funding as it was a design-bid-build process.

FISCAL IMPACT:

Change order amount of \$35,871.09. Part of 2022-2023 budget CIP20-21 in the amount of \$1,500,000. The final construction cost is \$1,948,643.47 over two fiscal years.

ALTERNATIVE:

None. Project close out change order.

CONCURRENCE:

By:  _____

SIGNATURE:

By:  _____

Approved By:  _____



AIA[®]

Document G701[®] – 2017

Change Order

PROJECT: *(Name and address)*
Charlie Louis Fire Station Addition and
Renovation/Expansion
424 8th Street
Columbus, NE 68602

CONTRACT INFORMATION:
Contract For: General Construction

CHANGE ORDER INFORMATION:
Change Order Number: 002

Date: May 16, 2022

Date: August 7, 2023

OWNER: *(Name and address)*
City of Columbus

ARCHITECT: *(Name and address)*
WSKF, Inc.

CONTRACTOR: *(Name and address)*
B-D Construction, Inc
2154 E. 32nd Ave
Columbus, NE 68601

2500 14th Street
P.O. Box 1677
Columbus, NE 68602-1677

110 Armour Road
North Kansas City, MO 64116

THE CONTRACT IS CHANGED AS FOLLOWS:

(Insert a detailed description of the change and, if applicable, attach or reference specific exhibits. Also include agreed upon adjustments attributable to executed Construction Change Directives.)

1. Per B-D Construction, Inc's Change Order Proposal 003, dated 8/17/2022, for additional cost to terminate and test City's Data Lines and install City provided hardware per PR003, **resulting in an add:**
\$ 5,022.96
2. Per B-D Construction, Inc's Changer Order Proposal 005, dated 8/27/2022, for additional cost to add a new community vault for the existing underground telephone line and conduit to the new IT room per PR005, **resulting in an add:**
\$ 8,749.50
3. Per B-D Construction, Inc's Change Order Proposal 006, dated 12/08/2022, for additional cost to add conduit from each floor box to West wall of Dayroom for future cable routing per PR006, **resulting in an add:**
\$ 1,230.54
4. Per B-D Construction, Inc's Change Order Proposal 009, dated 12/19/2022, for additional cost to add a wing wall to the East of the casework in the Kitchen at the transition between new and existing wall construction per PR009, **resulting in an add:**
\$ 349.65
5. Per B-D Construction, Inc's Change Order Proposal 010, dated 01/27/2023, for additional cost for the plumber to install the owner provided ice maker per PR010, **resulting in an add:**
\$ 354.96
6. Per B-D Construction Inc's Change Order Proposal 012, dated 2/01/2023, for additional cost to replace additional sidewalks and pavement at the front entrance to accommodate sanitary sewer tie-in, **resulting in an add:**
\$ 4,051.31
7. Per B-D Construction Inc's Change Order Proposal PR012, dated 03/07/2023, for additional cost to add conduit with pull string from Mech/Storage room 111 to IT room 132 for installation of fiber per PR012, **resulting in an add:**
\$ 2,241.48
8. Per B-D Construction Inc's Change Order Proposal PR013, dated 03/07/2023, for additional cost to move electric heaters to different panelboards per PR013, **resulting in an add:**
\$ 2,035.39

9. Per B-D Construction Inc's Change Order Proposal PR015, dated 03/16/2023, for additional cost for GFCI receptacles in lieu of non-protected receptacles to protected panelboard circuits due to code official request per PR015, **resulting in an add: \$ 1,723.59**

10. Per B-D Construction Inc's Change Order Proposal 016, dated 4/5/2023, for added additional steel front porch column and adjust gate anchorage to building and galvanizing of gate material and additional hardware, **resulting in an add: \$2,962.58**

11. Per B-D Construction Inc's Change Order Proposal 017 dated 4/5/2023, for cost to paint the CMU of the Hose Tower, **resulting in an add: \$1,329.77**

12. Per B-D Construction Inc's Change Order Proposal 018, dated 4/12/2023, for new Type U light fixtures to replace originally specified fixtures per the response to RFI 023, **resulting in an add: \$553.67**

13. Per B-D Construction Inc's Change Order Proposal 019 dated 7/28/2023, for cost to supply and install Hose Reels in the Apparatus Bay, **resulting in an add: \$3,024.21**



14. Per B-D Construction Inc's Change Order Proposal 020, dated 3/7/2023, for additional cost to add 2" conduit with pull string from Mech Storage room 111 to IT room 132 for installation of fiber per PR012, **resulting in an add: \$2,241.48**

The original Contract Sum was	\$	1,802,494.00
The net change by previously authorized Change Orders	\$	110,278.38
The Contract Sum prior to this Change Order was	\$	1,912,772.38
The Contract Sum will be increased by this Change Order in the amount of	\$	35,871.09
The new Contract Sum including this Change Order will be	\$	1,948,643.47

The Contract Time will be increased by Zero (0) days.
The new date of Substantial Completion will be unchanged.

NOTE: This Change Order does not include adjustments to the Contract Sum or Guaranteed Maximum Price, or the Contract Time, that have been authorized by Construction Change Directive until the cost and time have been agreed upon by both the Owner and Contractor, in which case a Change Order is executed to supersede the Construction Change Directive.

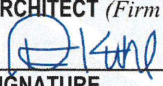
NOT VALID UNTIL SIGNED BY THE ARCHITECT, CONTRACTOR AND OWNER.

WSKF, Inc. ARCHITECT (Firm name)	B-D Construction, Inc CONTRACTOR (Firm name)	City of Columbus OWNER (Firm name)
 SIGNATURE	 SIGNATURE	 SIGNATURE
Rick Kuhl, Principal PRINTED NAME AND TITLE	BRYAN KEARNEY, TREASURER PRINTED NAME AND TITLE	 PRINTED NAME AND TITLE
August 15, 2023 DATE	8.23.23 DATE	 DATE



2154 E. 32nd Avenue
 Columbus, NE 68601
 (Phone) 402-564-1225
 (Fax) 402-564-9999

CHANGE ORDER PROPOSAL

NO.

003

PROJECT: Columbus Fire Station #2
COP NO.: 003

DATE QUOTED: 08/17/22

PROJECT NO.: 22-024

ARCH. PROJECT NO.: A-1588

TO: Rick Kuhl
 WSKF Architects Inc.
 110 Armour Road
 North Kansas City, MO 64116
 (Phone) 816.300.4101 (Fax) 816.300.4102

DAYS ALLOWED FOR APPROVAL:

EXPIRATION DATE: 08/17/22

REQUESTED EXTENSION OF TIME IN DAYS:

DESCRIPTION:

Terminate and Test City's Data Lines and install City provided hardware

SUBCONTRACTORS / VENDORS	SUB / VENDOR WORK DESCRIPTION	AMOUNT:
Kidwell Electric	Low Voltage	\$4,608.00
B-D Construction, Inc.	5% Mark Up on Sub Contractors	\$230.40
B-D Construction, Inc.	Project Manager COP Processing	\$125.00

APPROVAL

TOTAL FROM WORK BREAKDOWN PAGES

NAME: _____	SUB SUBTOTAL:	\$4,963.40
DATE: _____	BOND: 1.2%	\$59.56
SEND COPIES TO		\$0.00
B-D Construction, Inc., Bryan Kearney		\$0.00
WSKF Architects Inc., Rick Kuhl		
City of Columbus, Rick Bogus	SUBTOTAL:	\$5,022.96
B-D CONSTRUCTION, INC.		
BY: <i>Bryan L Kearney</i>	SUBTOTAL:	\$5,022.96
Bryan Kearney, Project Manager		\$0.00
DATE: 8/17/22	TOTAL COP AMOUNT:	\$5,022.96

Proposed Change Order

Number: 22-0093-10 PCO#1

3333 Folkways Cir
Lincoln, NE 68504
(402) 475-9151
FAX (402) 475-9186



To: B-D Construction Attn: Bryan Kearney	Phone: 402-564-1225	Fax: -	Date: 7/28/22
	Job Name/Location: Columbus Fire Station #2 Columbus, NE		

Change is per PR#03 dated 07/07/2022. Kidwell will terminate and test data lines. See attached breakdown.

Notes

- 1) **MATERIAL PROCUREMENT NOR INSTALLATION WILL BEGIN UNTIL A FULLY EXECUTED CHANGE ORDER HAS BEEN RECEIVED BY KIDWELL.**
- 2) Change does not include any patching, painting, or repair of any surface.
- 3) All work to be completed during Kidwell's normal business hours.
- 4) Change will impact schedule, and require 0 business day(s) time extension.
- 5) No sales tax has been included for material and labor in this proposal.
- 6) All other required taxes will be charged and added to the proposal price on invoicing.
- 7) Change does not include any cabling or terminations for the cameras

NOTE: This Proposed Change Order is only good for 10 days due to the rising cost of commodities.
NOTE: This Proposed Change Order becomes part of and in conformance with the existing contract.

CONFIDENTIALITY NOTICE: *This proposal and/or change order and any attachments are strictly confidential and are intended solely for the use of the individual or entity to whom it is addressed. This communication may contain proprietary and financial data of Kidwell Inc. If you are not the intended recipient, be advised that any use, dissemination, forwarding, printing, or copying of this proposal and/or change order and any file attachments is strictly prohibited.*

We Agree hereby to make the change(s) specified above at this price **ADD \$4,608.00**
Four Thousand Six Hundred Eight Dollars and 00/100 Cents.

Proposed Change Order Prepared By: <u>Ryan Gibbs</u>	PREVIOUS CONTRACT AMOUNT:
Authorized Kidwell Representative Signature: _____ (CONTRACTOR)	REVISED CONTRACT AMOUNT:

Payment will be made as follows: **MONTHLY**
*Accounts not paid within thirty days are subject to a finance charge of 1% monthly, and an annual rate of 12%.

Accepted- The above prices and specifications of the Change Order are satisfactory and are hereby accepted. All work to be performed under same terms and conditions as specified in original contract unless otherwise stipulated.	Authorized Signature: _____ (OWNER)
	Date of Acceptance: _____



DATE:

7/27/2022

ESTIMATED BY:

RG

NAME OF PROJECT:

City of Columbus Fire Station

CHECKED BY:

LG

BID DESC:

PCO 1

COST ITEM	Qty.	Material Unit	Material Totals	Labor Unit	Labor MHS
1. Electrical Fixtures			0.00		0.00
2. Material Staging/Handling			0.00		0.00
CAT 6 JACK	106		0.00	0.300	31.80
FACEPLATES	53		0.00	0.075	3.98
LABELING	106	0.25	26.50	0.030	3.18
TEST	53	1.00	53.00	0.200	10.60
4" SAF-T-GRIP TIE	53	0.90	47.70	0.053	2.78
WIRE TIE-MEDIUM	159	0.11	17.49	0.030	4.77
Total Items (1) thru (3) and Labor MH'S			144.69		57.11

4) Labor

a) Total MH'S			57.11	
b) Paid Holiday's Factor			0.00	
c) Productivity Factor			0.00	
d) Height Adj. Factor			0.00	
e) Job Cond. Factor			0.00	
Adjusted MH'S			57.11	
f)	58	MH'S Field Staff	63.55	3685.90
g)	1	MH'S Project Mgr.	85.05	85.05
h)	1	MH'S Superintendant	73.75	73.75
i) Sub-Total Labor			3844.70	
j) Material Tax		0.00 %		0.00
Total Items a-j				3,844.70

5) Subcontracts

a)	
b)	
c)	
d)	
e)	
f)	
g)	

Total Cost Item 5	0.00
--------------------------	------

6) Other Costs

a)	
b)	
c)	
d)	
e)	

Total Cost Item 6	0.00
--------------------------	------

Total Cost Item 1 thru 6			\$3,989.39
Job Overhead Cost			
Add or deduct sheet			
Total Prime Cost			\$3,989.39
Overhead	10	%	\$398.94
Total Cost			\$4,388.33
Profit	5	%	\$219.42
Sub-Total Selling			\$4,607.75
Bond	0	%	\$0.00
Total Selling Price			\$4,608.00



110 Armour Rd
 North Kansas City, MO 64116
 p. 816.300.4101
 wskfarch.com

PROPOSAL REQUEST

Proposal Request No.: **003 (THREE)**
 Date: 07/07/2022
 Project: Columbus Fire Station #2

Owner: City of Columbus, NE
 To: Bryan Kearney
 B-D Construction, Inc.

Project No.: 20023
 Contract For: General Construction
 Contract Dated: 05/16/2022

Please submit an itemized quotation for changes in the Contract Sum and/or Contract Time, if any, for the proposed modifications to the Contract Documents described herein.

THIS IS NOT A CHANGE ORDER, OR A DIRECTION TO PROCEED WITH THE WORK DESCRIBED HEREIN.

Description:

1. B-D Construction to terminate and test data lines per the City's request.
2. City IT will provide the following hardware in lieu of B-D Construction.
 - a. Wall Mounted phones with keystone phone wall plates
 - b. TV's with recessed wall box and GFCI faceplates
 - c. Cameras direct wired (CAT6 plug)
 - d. Access Points wired to keystone jack, with surface mount box, then patch cable to access point
3. B-D Construction to confirm quantities below.

Part #	Description	D1 Wallplate	D2 Wallplate	D1 Phone	D1 TV	D1 WAP	D1 Camera	Total
NKF2S	NetKey Stainless Steel 2-Position Faceplate with Labels	2	15					17
NK2RMFWH	NetKey 2-Position GFCI Faceplate (White)				7			7
KWPY	Pan-Net® Phone Plate			4				4
180071x5	Cable Meters 5-Pack 1-Port Keystone Jack Surface Mount Box					3		3
NK688MBU	NetKey Jack Module (Blue)	2	30	4				36
NKBMIG-X	NetKey Blank Module (Industrial Gray)	2						2
NK688MWH	NetKey Jack Module (White)				7	3		10
NKBMWH-X	NetKey Blank Module (White)				7			7
CAT6 End	CAT6 RJ45 End						7	7

IT Room Hardware

2POSTRACK	2 Post Rack (bolted to floor)							1
WMPFSE	PatchLink™ Horizontal Single Sided Manager, 1RU							1
WMPF1E	PatchLink™ Horizontal Single Sided Manager, 2RU							2

NK6PPG48Y Cat 6 Punchdown Keystone Patch Panel, 48 Port
 NK6PPG24Y Cat 6 Punchdown Keystone Patch Panel, 24 Port

Patch Panel Port Usage							
2	30	4	7				43
				3	7		10

Attachments: None

Signed: Matt McCaffrey
 WSKF, Inc.



2154 E. 32nd Avenue
 Columbus, NE 68601
 (Phone) 402-564-1225
 (Fax) 402-564-9999

CHANGE ORDER PROPOSAL

NO.

005

PROJECT: Columbus Fire Station #2
COP NO.: 005

DATE QUOTED: 08/27/02

PROJECT NO.: 22-024

ARCH. PROJECT NO.: A-1588

TO: Rick Kuhl
 WSKF Architects Inc.
 110 Armour Road
 North Kansas City, MO 64116
 (Phone) 816.300.4101 (Fax) 816.300.4102

DAYS ALLOWED FOR APPROVAL:

EXPIRATION DATE: 08/27/02

REQUESTED EXTENSION OF TIME IN DAYS:

DESCRIPTION:

1. Revise location of Transformer
2. Add "community Vault" over the existing UGT to the building
3. Add (1) 2" conduit with pull strings for telecommunications cabling
4. Route fiber overhead to IT Room 132 via cable tra
5. Add (1) 2" conduit with pull strings for telecommunicatiосn cabling

SUBCONTRACTORS / VENDORS

SUB / VENDOR WORK DESCRIPTION

AMOUNT:

Kidwell	Electrical	\$8,115.00
---------	------------	------------

B-D Construction, Inc.	5% Mark Up on Sub Contratctors	\$405.75
------------------------	--------------------------------	----------

B-D Construction, Inc.	Project Manager COP Processing	\$125.00
------------------------	--------------------------------	----------

APPROVAL

TOTAL FROM WORK BREAKDOWN PAGES

SUB SUBTOTAL: \$8,645.75

NAME: _____

BOND: 1.2% \$103.75

DATE: _____

\$0.00

SEND COPIES TO

\$0.00

B-D Construction, Inc., Bryan Kearney
 City of Columbus, Rick Bogus
 WSKF Architects Inc., Rick Kuhl

\$0.00

SUBTOTAL: \$8,749.50

B-D CONSTRUCTION, INC.

BY: *Bryan L Kearney*
 Bryan Kearney, Project Manager

SUBTOTAL: \$8,749.50

\$0.00

DATE: 8/27/02

TOTAL COP AMOUNT: \$8,749.50

Proposed Change Order

Number: 22-0093-10 PCO#4R2

3333 Folkways Cir
Lincoln, NE 68504
(402) 475-9151
FAX (402) 475-9186



To: B-D Construction Attn: Bryan Kearney	Phone: 402-564-1225	Fax: -	Date: 1/3/23
	Job Name/Location: Columbus Fire Station #2 Columbus, NE		

Change is per PR#5R2 dated 8/19/2022. See attached breakdown.

Notes

- 1) **MATERIAL PROCUREMENT NOR INSTALLATION WILL BEGIN UNTIL A FULLY EXECUTED CHANGE ORDER HAS BEEN RECEIVED BY KIDWELL.**
- 2) Change does not include any patching, painting, or repair of any surface.
- 3) All work to be completed during Kidwell's normal business hours.
- 4) Change will impact schedule, and require 0 business day(s) time extension.
- 5) No sales tax has been included for material and labor in this proposal.
- 6) All other required taxes will be charged and added to the proposal price on invoicing.
- 7) New conduits shown on sheet MEP1.01 are figured from the building to vault locations only. Extension of raceways for service providers are not included.
- 8) 17x30 vault are being provided. Estimated lead time is 5-6 months
- 9) Fiber to be provided and installed by others.

NOTE: This Proposed Change Order is only good for 10 days due to the rising cost of commodities.

NOTE: This Proposed Change Order becomes part of and in conformance with the existing contract.

CONFIDENTIALITY NOTICE: *This proposal and/or change order and any attachments are strictly confidential and are intended solely for the use of the individual or entity to whom it is addressed. This communication may contain proprietary and financial data of Kidwell Inc. If you are not the intended recipient, be advised that any use, dissemination, forwarding, printing, or copying of this proposal and/or change order and any file attachments is strictly prohibited.*

We Agree hereby to make the change(s) specified above at this price **ADD \$8,115.00**
Eight Thousand One Hundred Fifteen Dollars and 00/100 Cents.

Proposed Change Order Prepared By: <u>Brian Mostek</u>	PREVIOUS CONTRACT AMOUNT:
	REVISED CONTRACT AMOUNT:
Authorized Kidwell Representative Signature: _____ (CONTRACTOR)	

Payment will be made as follows: **MONTHLY**
*Accounts not paid within thirty days are subject to a finance charge of 1% monthly, and an annual rate of 12%.

Accepted- The above prices and specifications of the Change Order are satisfactory and are hereby accepted. All work to be performed under same terms and conditions as specified in original contract unless otherwise stipulated.	Authorized Signature: _____ (OWNER)
	Date of Acceptance: _____



DATE: 1/3/2023	ESTIMATED BY: Brian M.
NAME OF PROJECT: Columbus Fire Department - Fire Station #2	CHECKED BY: LG
BID DESC: PCO#4R2 - PR#5R - Add Data Vault	

COST ITEM	Qty.	Material Unit	Material Totals	Labor Unit	Labor MHS
1. Electrical Fixtures			0.00		0.00
2. Material Staging/Handling			0.00		0.00
2" PVC SCH 40	232	3.45	800.40	0.105	24.36
2" EMT	22	5.20	114.40	0.105	2.31
2" PVC SCH 40 90 ELBOW	4	5.65	22.60	0.300	1.20
2" PVC COUPLING	8	1.28	10.24	0.150	1.20
2" PVC END BELLS	2	12.82	25.64	0.225	0.45
2" PVC BOX ADPT/MALE	2	1.79	3.58	0.225	0.45
2" INSULAT BUSH	2	0.76	1.52	0.120	0.24
2" EMT STEEL SS CONN	4	6.08	24.32	0.195	0.78
2" LOCKNUT	2	1.57	3.14	0.090	0.18
2" PLASTIC BUSHINGS	6	5.91	35.46	0.375	2.25
SIZE 1 FASTENERS #1	8	0.07	0.56	0.015	0.12
SIZE 2 FASTENERS #2	4	0.24	0.96	0.030	0.12
2" MINERALLAC STRAP	4	1.05	4.20	0.090	0.36
TEK SCREWS	8	0.04	0.32	0.030	0.24
CHANNEL 12GA 1-5/8"	1	6.25	6.25	0.150	0.15
2" UNISTRUT STRAP	2	1.86	3.72	0.045	0.09
NYLON LINE	276	0.10	27.60	0.002	0.41
6W X 36D TRENCHER DITCHING	106	3.07	325.42	0.098	10.39
6" WARNING TAPE MAG.	106	0.15	15.90	0.006	0.64
17X30X24 IN GROUND BOX W/COVER	1	1924.00	1924.00	7.875	7.88
3. Miscellaneous (list items)			0.00		0.00
Total Items (1) thru (3) and Labor MH'S			3,350.23		53.81

4) Labor

a) Total MH'S			53.81	
b) Paid Holiday's Factor			0.00	
c) Productivity Factor			0.00	
d) Height Adj. Factor			0.00	
e) Job Cond. Factor			0.00	
Adjusted MH'S			53.81	
f)	54	MH'S Field Staff	63.55	3431.70
g)	2	MH'S Project Mgr.	85.05	170.10
h)	1	MH'S Superintendant	73.75	73.75
i) Sub-Total Labor			3675.55	
j) Material Tax		0.00 %		0.00
Total Items a-j				3,675.55

5) Subcontracts

a)	
b)	
c)	
d)	
e)	
f)	
g)	

Total Cost Item 5	0.00
--------------------------	------

6) Other Costs

a)	
b)	
c)	
d)	
e)	

Total Cost Item 6	0.00
--------------------------	------

Total Cost Item 1 thru 6		\$7,025.78
Job Overhead Cost		
Add or deduct sheet		
Total Prime Cost		\$7,025.78
Overhead	10 %	\$702.58
Total Cost		\$7,728.36
Profit	5 %	\$386.42
Sub-Total Selling		\$8,114.78
Bond	0 %	\$0.00
Total Selling Price		\$8,115.00



110 Armour Rd
North Kansas City, MO 64116
p. 816.300.4101
wskfarch.com

PROPOSAL REQUEST

Proposal Request No.: **005r (FIVE)**
Date: 08/19/2022
Project: Columbus Fire Station #2

Owner: City of Columbus, NE
To: Bryan Kearney
B-D Construction, Inc.

Project No.: 20023
Contract For: General Construction
Contract Dated: 05/16/2022

Please submit an itemized quotation for changes in the Contract Sum and/or Contract Time, if any, for the proposed modifications to the Contract Documents described herein.

THIS IS NOT A CHANGE ORDER, OR A DIRECTION TO PROCEED WITH THE WORK DESCRIBED HEREIN.

Description:

1. Sheet C3.1 – Site Construction
 - a. Revised Transformer Locker location per utility company location.
2. Sheet MEP1.01 – Vault & Conduit Addition
 - a. Add new “Community Vault” over the existing UGT to the building.
 - b. Add (1) 2” conduit with pull strings for telecommunications cabling.
3. Sheet E3.01 – Conduit into Building
 - a. Route fiber overhead to IT Room 132 via cable tray.
 - b. Add (1) 2” conduit with pull strings for telecommunications cabling.

Attachments: C3.1, MEP1.01, E3.01

Signed: Matt McCaffrey
WSKF, Inc.

CONSTRUCTION NOTES

- Contractor shall provide protective covers during construction to protect the adjoining concrete, and building during concrete placement. Any concrete splatters to surrounding concrete, walls, doors, fencing, etc., shall be removed immediately by the contractor.
- Final grading and shaping by the contractor shall be ready for the placement of sod/seed.
- Contractor shall protect underground sprinklers, sprinkler lines, and valve boxes during construction.
- Contractor shall protect underground electrical, gas, and communication lines during construction.
- All concrete and building materials removed during construction shall be properly disposed by the contractor.
- The location of all aerial and underground utility facilities are approximate or may not be indicated on these drawings. Underground utilities whether shown or not, will be located and marked by the Utilities at the request of the Contractor. No excavation will be performed until all such underground utility facilities have been located and identified to the satisfaction of all parties. Contractor shall use extreme care to avoid any possibility of damage to the utility facility. It shall be the responsibility of the Contractor to protect all existing utilities, pavement, and other improvements not designated for removal or abandonment. Any damage to existing utilities and/or paved streets not designated for removal caused by construction operations shall be repaired at the Contractor's expense. In all cases, with no exception the Contractor before beginning construction, shall locate, uncover, and determine the horizontal and vertical location of all existing underground facilities which may potentially conflict with the work. Before proceeding with any digging the Contractor shall confirm that a conflict does not exist and the underground work may be performed as shown on the drawings. If the Contractor determines that a conflict does exist, the Contractor shall immediately notify the Engineer who will make the final determination for resolving the conflict. The Contractor will receive no additional compensation for any delays or work resulting from a conflict that has not been thoroughly investigated prior to proceeding with the work. The Contractor may request additional compensation for any additional work performed to directly resolve the conflict as directed in writing by the Engineer.
- Contractor shall call for utility location (1-800-331-5666) 48 hours prior to digging.
- The Contractor shall adjust to grade all communication and electrical boxes. Contractor shall keep existing utility boxes free of all debris and operable during construction.
- Contractor shall furnish and maintain all necessary barricades, warning signs, lights, and flag persons as necessary for no additional compensation.
- Contractor shall protect by whatever means are required, all signs, mail boxes, fences, driveways, structures, sidewalks, streets, utility poles, bushes, trees, sprinkler systems, etc., which are not designated for removal or are located outside of the project limits. Any damage or destruction caused by the Contractor shall be repaired or replaced at a minimum to the original condition, as determined by the Engineer, at the Contractor's expense.
- Contractor shall provide positive drainage at all times within the project and construction areas.
- Contractor shall obtain the SWPPP permit, if total area disturbed exceeds 1.0 acres. Contractor shall provide and maintain temporary erosion control devices in conformance with the SWPPP permit or by Owner.
- Contractor is responsible for all traffic and pedestrian control including, but not limited to, signage, barricades, construction fencing, warning lights, and related items. All materials and procedures shall be in conformance with the NDOT Standard Materials list, and Manual of Uniform Traffic Control Devices.
- Expansion joint to be provided between concrete and building walls.
- Expansion joint around stoops and areas shown on sheet C3.3.

10 | 9 | 8 | 7 | 6 | 5 | 4 | 3 | 2 | 1

H
G
F
E
D
C
B
A

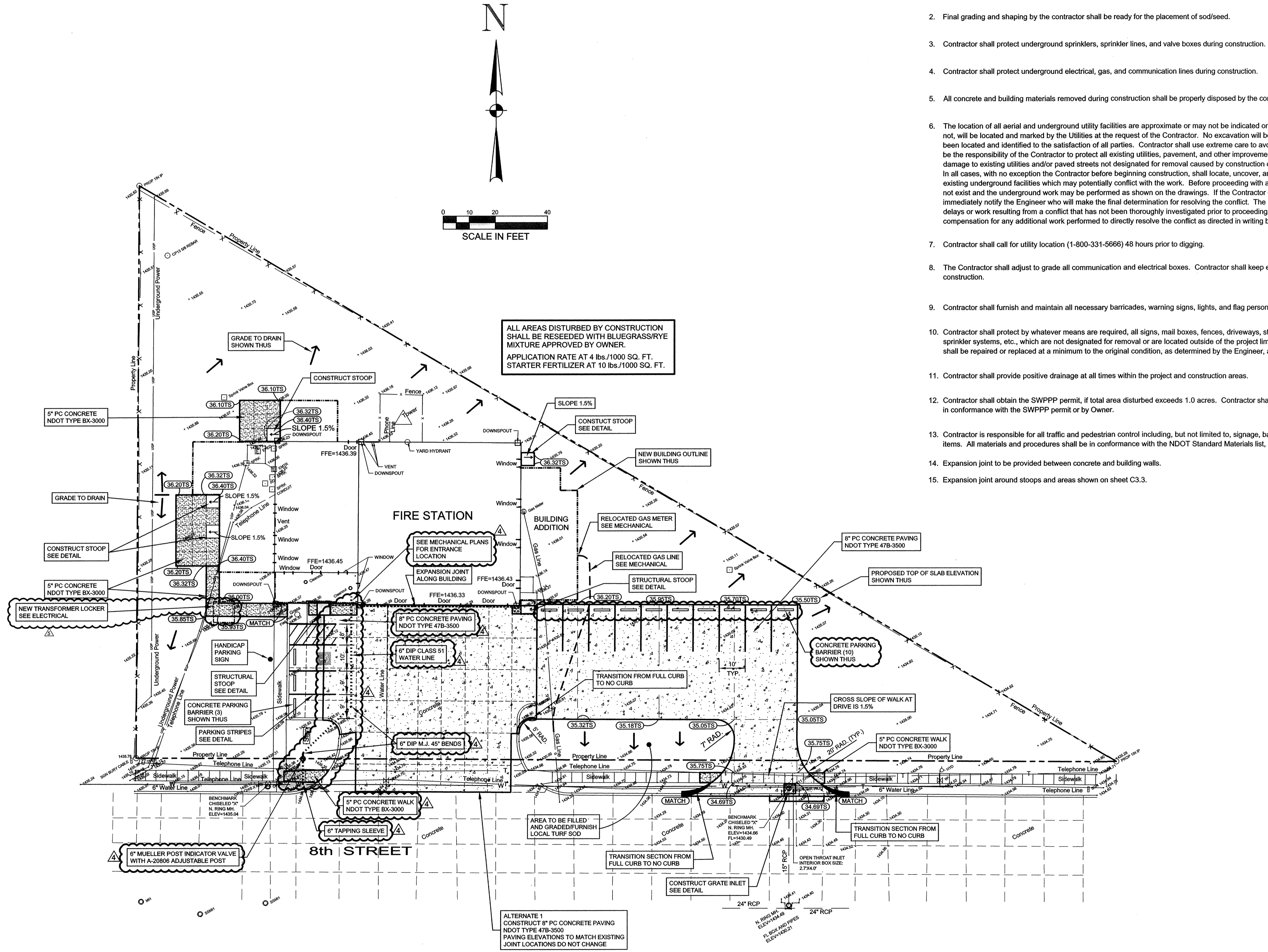
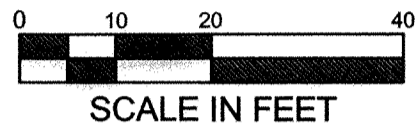
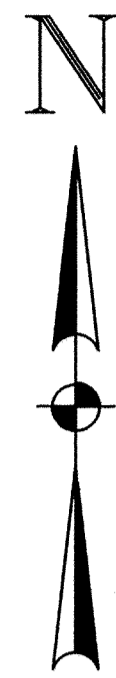

ALL AREAS DISTURBED BY CONSTRUCTION SHALL BE RESEED WITH BLUEGRASS/RYE MIXTURE APPROVED BY OWNER. APPLICATION RATE AT 4 lbs./1000 SQ. FT. STARTER FERTILIZER AT 10 lbs./1000 SQ. FT.

SITE CONSTRUCTION
SCALE: 1"=20'

SYMBOL	DESCRIPTION
○	Water Curb Stop
○	Property Corner
○	NGS (Station Monument)
○	Control Point
○	Sewer Manhole
○	Sign
○	Deciduous Tree
○	Power Pole
○	Anchor
○	Air Cond.
○	Fire Hydrant
○	Confiferous Tree
○	Light Pole
○	Deciduous Bush
○	Confiferous Shrub
○	Telephone Pedestal
○	Post
○	Elec. Pedestal
○	Water Valve
○	Sprinkler
○	Gas Meter
○	Storm Sewer Manhole
○	Guy Anchor



Nebraska Certificate of Authority #CA4038

Civil Engineer
Gilmore & Associates
State Certificate of Authority #000000000
2670 33rd Avenue
Columbus, NE 68601
402-544-2807

Structural Engineer
Bob D. Campbell & Co.
State Certificate of Authority #000000000
4338 Bellevue
Kansas City, MO 64111
816-531-4144

MEP Engineer
PKMR Engineers, LLC
State Certificate of Authority #000000000
13300 W. 98th Street
Lenexa, KS 66215
913-342-2400

JOB NUMBER 20023

STATION #2 RENOVATION/EXPANSION

424 8TH STREET
COLUMBUS, NE 68601

CITY OF COLUMBUS, NE
110 Armour Road North Kansas City, Missouri 64116 Tel: 816.300.4101 Fax: 816.300.4102



Richard A. Kuhl - Architect
NE # A-1588

PERMIT DOCUMENTS

ISSUE DATE	Description	Date
03/09/2022		
04/06/2022	ADD003	
7/26/2022	PR004	
8/19/2022	PR005	

WSKF, Inc. © 2022

SITE CONSTRUCTION

C3.1

C:\Users\WaltMcCaffrey\Desktop\2022\20220323_Station Expansion_CENTRAL_2022_nmccaffrey@wskfarch.com.plt



Missouri Certificate of Authority #2003011262

Civil Engineer Gilmore & Associates State Certificate of Authority #000000000 2670 33rd Avenue Columbus, NE 68601 402-564-2807

Structural Engineer Bob D. Campbell & Co. State Certificate of Authority #000000000 4338 Bellevue Kansas City, MO 64111 816-531-4144

MEP Engineer PKMR Engineers, LLC State Certificate of Authority #000000000 13300 W. 78th Street Lenexa, KS 66215 913-342-2400

GENERAL SITE PLAN NOTES

- REFER TO GENERAL NOTES ON MEP COVER SHEET FOR ADDITIONAL REQUIREMENTS OF WORK.
- REFER TO CIVIL PLANS FOR CONTINUATION OF SERVICES BEYOND 5'-0" FROM BUILDING UNLESS OTHERWISE SHOWN.
- REFER TO RESPECTIVE FLOOR PLANS FOR CONTINUATION OF SERVICES INSIDE BUILDING AND/OR EXACT LOCATIONS OF EQUIPMENT.
- CONTACT UTILITY LOCATING SERVICE TO LOCATE EXACT LOCATION OF ALL EXISTING UTILITIES BELOW GRADE.

SITE PLAN KEYED NOTES

- WARNING TAPE ON PRIMARY CONDUITS. INSTALL PER UTILITY COMPANY STANDARDS.
- EXTEND AS DIRECTED BY UTILITY COMPANY/SERVICE PROVIDER.
- REFER TO RISER DIAGRAM FOR ADDITIONAL INFORMATION.
- (1) 2" CONDUIT WITH PULLSTRINGS FOR TELECOMMUNICATIONS CABLING. REFER TO SHEET E3.01 FOR CONTINUATION.
- ROUTE THROUGH REMOTE CONTROL SWITCH RGS-1, THEN HOMERUN.
- REPLACE EXISTING FLAG POLE FLOOD FIXTURE, LOCATED ON ROOF, WITH NEW FIXTURE.
- REFER TO CIVIL PLANS FOR CONTINUATION.
- COMMUNITY VAULT INSTALLED OVER EXISTING LINE. FIELD VERIFY EXACT LOCATION. VAULT TO BE QUARTZITE 14"x30"x24" DEEP POLYMER CONCRETE IN GROUND BOX WITH DRIVE OVER RATED LOCKING LID, OR AS DIRECTED BY OWNER. INSTALL AS DIRECTED BY MANUFACTURER.

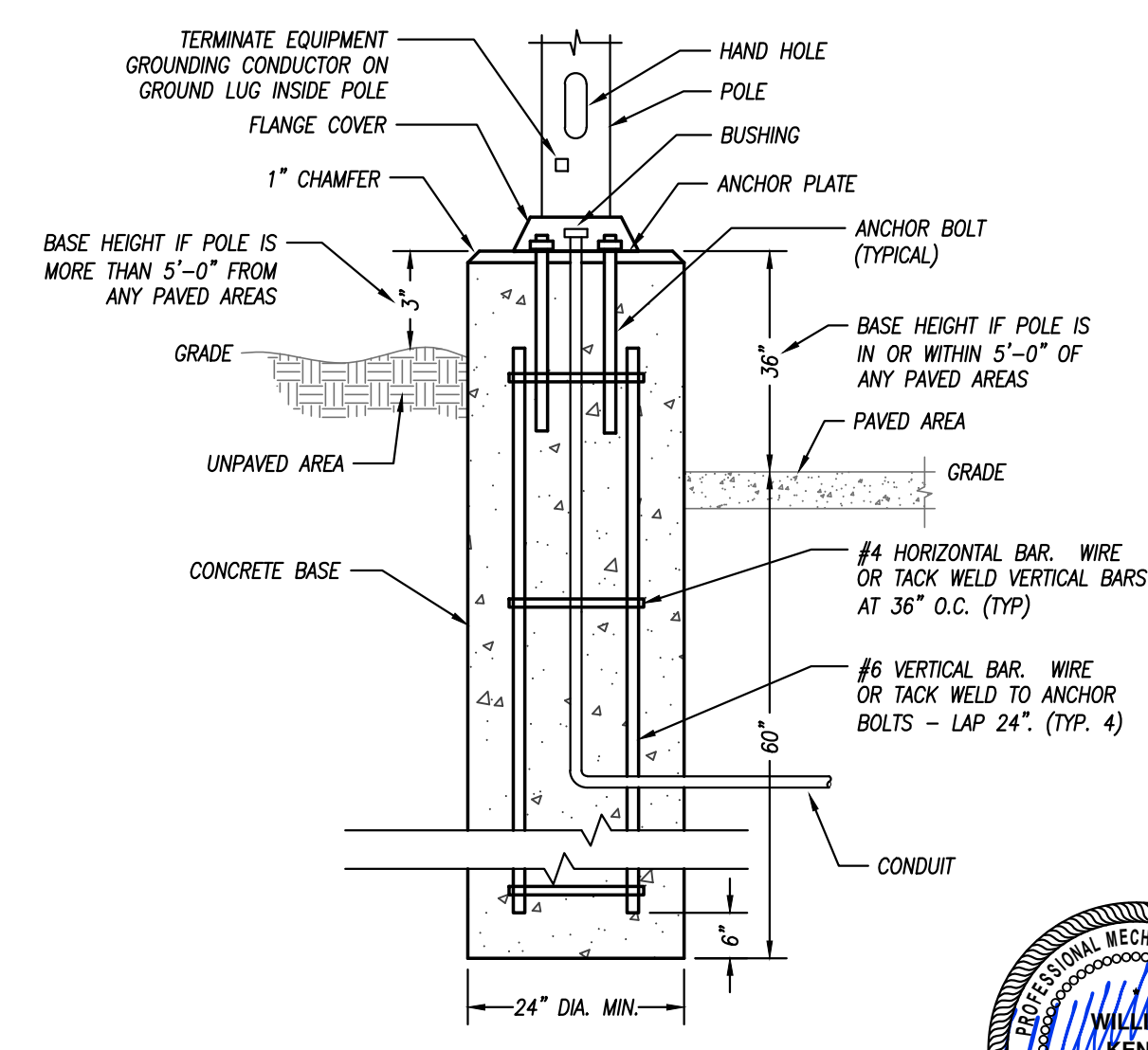
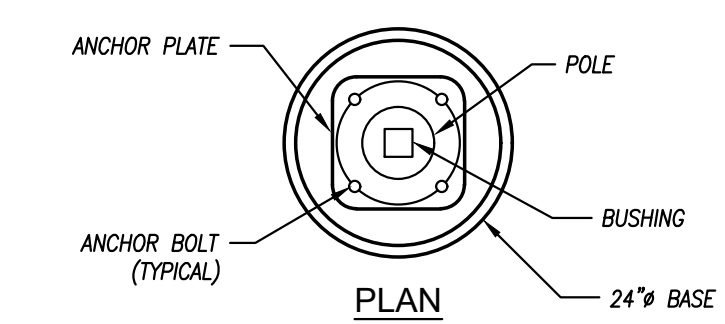
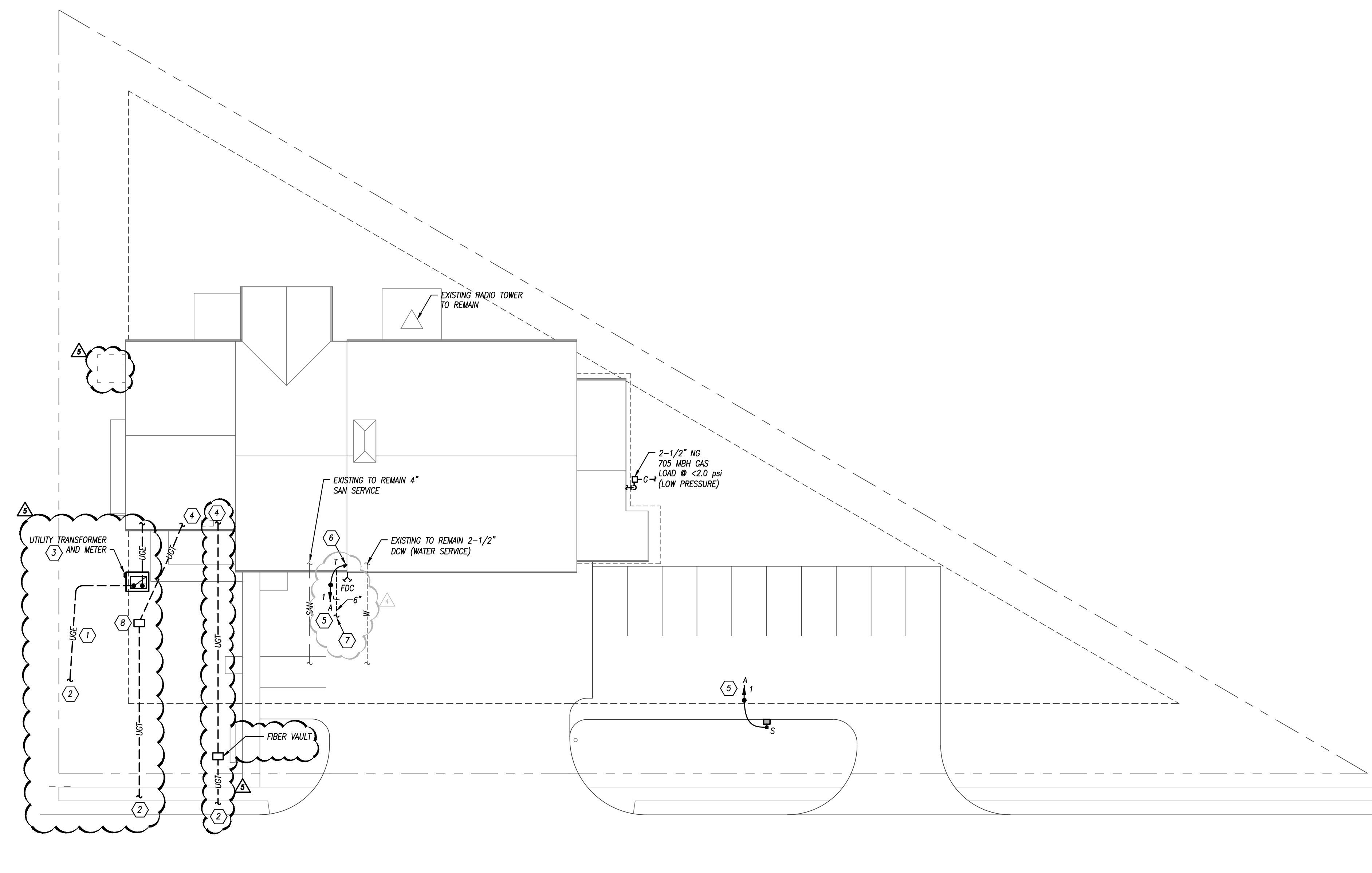

SECTION POLE BASE DETAIL NOT TO SCALE

JOB NUMBER 20023

CHARLIE LOUIS FIRE STATION ADDITION

424 8TH STREET COLUMBUS, NE 68601

CITY OF COLUMBUS, NE 110 Armour Road North Kansas City, Missouri 64116 Tel: 816.300.4101 Fax: 816.300.4102

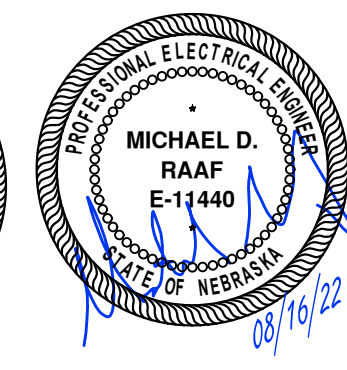
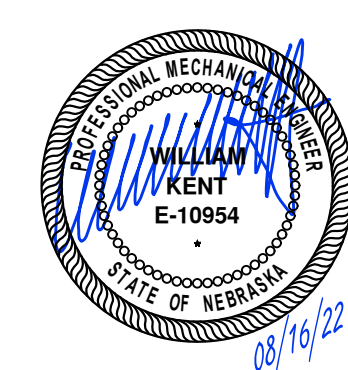

CONSTRUCTION DOCUMENTS

ISSUE DATE	03/09/2022
No Description	Date
▲ Addendum #2	03/25/22
▲ Addendum #3	04/06/22
▲ PRO04	07/26/22
▲ PRO05	08/16/22

SITE PLAN - MEP 1" = 20'-0"



PEARSON KENT MCKINLEY RAAF ENGINEERS LLC 13300 W 78TH STREET LENEXA, KS 66215 913.482.2400 WWW.PKMRENG.COM

SITE PLAN MEP1.01



Missouri Certificate of Authority #2003011262

Civil Engineer Gilmore & Associates State Certificate of Authority #000000000 2670 33rd Avenue Columbus, NE 68601 402-564-2807

Structural Engineer Bob D. Campbell & Co. State Certificate of Authority #000000000 4338 Bellevue Kansas City, MO 64111 816-531-4144

MEP Engineer PKMR Engineers, LLC State Certificate of Authority #000000000 13300 W. 76th Street Lenexa, KS 66215 913-342-2400

GEN. SPECIAL SYSTEMS NOTES

1. REFER TO GENERAL NOTES ON MEP COVER SHEET FOR ADDITIONAL REQUIREMENTS OF WORK.
2. REFER TO LOW VOLTAGE RISER DIAGRAMS / DETAILS FOR WORK THAT MAY NOT BE SHOWN ON PLANS.
3. EXACT MECHANICAL EQUIPMENT LOCATIONS MAY NOT BE SHOWN FOR CLARITY. COORDINATE EXACT LOCATIONS OF ALL MECHANICAL EQUIPMENT, DUCT DETECTORS, ETC. WITH MECHANICAL DRAWINGS AND CONTRACTOR.
4. COORDINATE EXACT LOCATIONS OF SMOKE DETECTORS WITH CEILING FANS, HVAC DIFFUSERS, SPRINKLER HEADS, ETC. PER NFPA REQUIREMENTS.

SPECIAL SYSTEMS KEYED NOTES

- 1 4"x8"x3/4" FIRE-RATED PLYWOOD BACKBOARD FOR TELECOMMUNICATIONS SERVICE ENTRANCE EQUIPMENT. MOUNT AT 6" AFF.
- 2 COORDINATE EXACT NUMBER/LOCATION OF TAMPER/FLOW SWITCHES, PRESSURE SWITCHES AND POINTS TO BE MONITORED WITH FIRE SPRINKLER CONTRACTOR.
- 3 GROUND BUS. RE. DETAIL AND RISER FOR MORE INFORMATION.
- 4 PROVIDE (1) 4" CONDUITS FOR TELECOMMUNICATIONS SERVICE ENTRANCE CABLING. FURNISH CONDUITS WITH PULLSTRINGS AND BUSHED ENDS.
- 5 CARBON MONOXIDE/NITROGEN DIOXIDE DETECTION SYSTEM. COORDINATED POWER AND WIRING WITH MECHANICAL CONTRACTOR. PROVIDE RECESSED BOX FOR INSTALLATION OF SENSOR AND 3/4" CONDUIT TO ABOVE ACCESSIBLE CEILING FOR WIRING. COORDINATED ROUGH-IN WITH SUPPLIER.
- 6 PROVIDE ROUGH-IN AND WIRING FOR NITROGEN DIOXIDE REMOTE SENSOR. PROVIDE RECESSED BOX FOR INSTALLATION OF SENSOR AND 3/4" CONDUIT TO ABOVE ACCESSIBLE CEILING FOR WIRING. CONDUIT ROUGH-IN WITH SUPPLIER.
- 7 PROVIDE ROUGH-IN AND WIRING FOR CARBON MONOXIDE REMOTE SENSOR. PROVIDE RECESSED BOX FOR INSTALLATION OF SENSOR AND 3/4" CONDUIT TO ABOVE ACCESSIBLE CEILING FOR WIRING. CONDUIT ROUGH-IN WITH SUPPLIER.
- 8 12" WIDE BASKET CABLE TRAY ABOVE CEILING.
- 9 DROP FOR WIRELESS ACCESS POINT.
- 10 CARD READER IS TO BE MOUNTED ON DOOR MULLION.
- 11 PROVIDE JUNCTION BOX ABOVE CEILING AT DOOR FOR POWER TO DOOR ACCESS CONTROL DEVICES, AND/OR MAG LOCK. RE. ARCHITECTURAL PLANS.
- 12 (2) 4" CONDUITS FOR FUTURE TOWER WIRING. FURNISH CONDUITS WITH PULLSTRINGS AND BUSHED ENDS. RUN CONDUIT TIGHT TO CEILING/STRUCTURE.
- 13 PAGING EQUIPMENT. WALL MOUNTED.
- 14 PROVIDE (2) 2" CONDUITS FROM IT ROOM ACROSS APPARATUS BAY FOR ACCESS CONTROL AND DATA CABLING.
- 15 POWER FOR SPEAKER. FIELD VERIFY EXACT LOCATION.
- 16 COMBINATION SMOKE/CARBON MONOXIDE ALARM.
- 17 ROUTE FIBER OVERHEAD TO IT ROOM 132 BY CABLE TRAY.
- 18 (1) 2" CONDUIT WITH PULLSTRINGS FOR TELECOMMUNICATIONS CABLING. REFER TO SHEET MEP1.01 FOR CONTINUATION.

SCOPE OF WORK

- ACCESS CONTROL**
ROUGH-IN OF BACKBOXES AND CONDUIT TO ABOVE ACCESSIBLE CEILING
- SURVEILLANCE CAMERA**
PROVIDE RECESSED BOX AND CONDUIT TO ACCESSIBLE CEILING FOR WALL MOUNT EXTERIOR CAMERAS.
- DATA**
PROVIDE RECESSED BOX AND CONDUIT TO ACCESSIBLE CEILING. PULL CAT 6 CABLING AND COIL 2' OF CABLE AT EACH BOX. COVERPLATES, JACKS AND TERMINATIONS DONE BY OTHERS.

NOTE

ALL DATA DROPS SHALL BE BLUE CATEGORY 6 CABLING AND ALL CAMERA DROPS SHALL BE WHITE CATEGORY 6 CABLING.

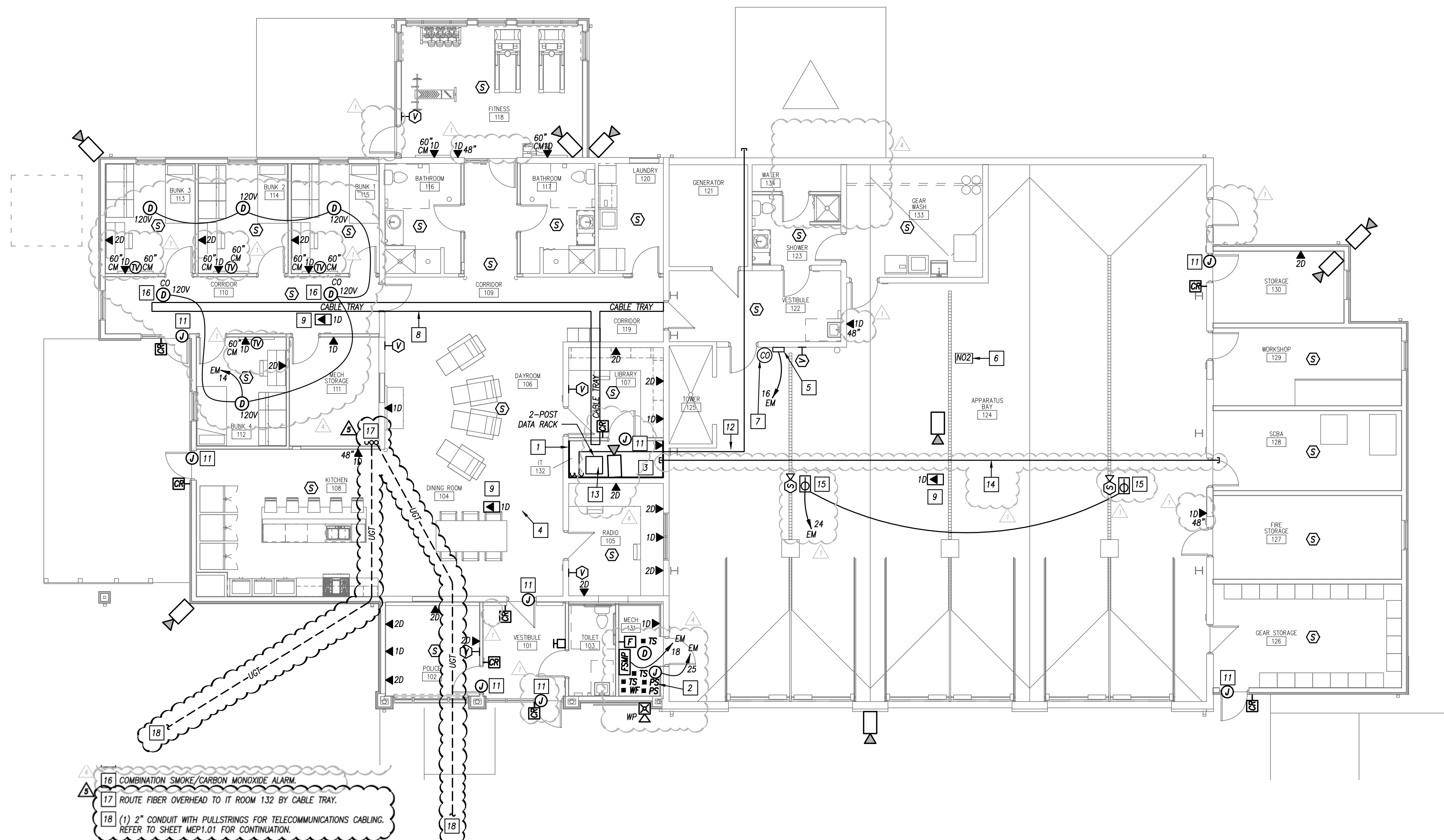

- 16 COMBINATION SMOKE/CARBON MONOXIDE ALARM.
- 17 ROUTE FIBER OVERHEAD TO IT ROOM 132 BY CABLE TRAY.
- 18 (1) 2" CONDUIT WITH PULLSTRINGS FOR TELECOMMUNICATIONS CABLING. REFER TO SHEET MEP1.01 FOR CONTINUATION.

FLOOR PLAN - SPECIAL SYSTEMS
1/8" = 1'-0"

JOB NUMBER 20023

CHARLIE LOUIS FIRE STATION ADDITION

424 8TH STREET
COLUMBUS, NE 68601

CITY OF COLUMBUS, NE
110 Armour Road North Kansas City, Missouri 64116 Tel: 816.300.4101 Fax: 816.300.4102



CONSTRUCTION DOCUMENTS

ISSUE DATE	03/09/2022
No Description	Date
▲ Addendum #2	03/25/22
▲ Addendum #3	04/06/22
▲ PRO04	07/26/22
▲ PRO05	08/16/22

WSKF, Inc. © 2022

SPECIAL SYSTEMS PLAN

E3.01



PEARSON KENT MCKINLEY RAAF ENGINEERS LLC
13300 W 76TH STREET
LENEXA, KS 66215
913.482.2400 WWW.PKMRNG.COM



2154 E. 32nd Avenue
 Columbus, NE 68601
 (Phone) 402-564-1225
 (Fax) 402-564-9999

CHANGE ORDER PROPOSAL

NO.

006

PROJECT: Columbus Fire Station #2
COP NO.: 006

DATE QUOTED: 12/08/22

PROJECT NO.: 22-024

ARCH. PROJECT NO.: A-1588

TO: Rick Kuhl
 WSKF Architects Inc.
 110 Armour Road
 North Kansas City, MO 64116
 (Phone) 816.300.4101 (Fax) 816.300.4102

DAYS ALLOWED FOR APPROVAL:
EXPIRATION DATE: 12/08/22
REQUESTED EXTENSION OF TIME IN DAYS:

DESCRIPTION:

Add conduit to Dayroom FB-1
 1. Add (1) 1-1/4" conduit from each FB-1 to West wall (wal between Dayroom & Mech. Storage) Extend conduit up wall (stud space) to top of wall; extend into attic space to all for future cable routing. Add pull strings between FB and top of conduit.

SUBCONTRACTORS / VENDORS	SUB / VENDOR WORK DESCRIPTION	AMOUNT:
Kidwell Electric	Electrical	\$1,039.00

B-D Construction, Inc.	5% Mark Up on Sub Contractors	\$51.95
B-D Construction, Inc.	Project Manager COP Processing	\$125.00

APPROVAL

TOTAL FROM WORK BREAKDOWN PAGES

NAME: _____	SUB SUBTOTAL:	\$1,215.95
DATE: _____	BOND: 1.2%	\$14.59
SEND COPIES TO		\$0.00
B-D Construction, Inc., Bryan Kearney		\$0.00
WSKF Architects Inc., Rick Kuhl		
City of Columbus, Rick Bogus	SUBTOTAL:	\$1,230.54
B-D CONSTRUCTION, INC.		
BY: <i>Bryan L Kearney</i>	SUBTOTAL:	\$1,230.54
Bryan Kearney, Project Manager		\$0.00
DATE: 12/8/22	TOTAL COP AMOUNT:	\$1,230.54

Proposed Change Order

Number: 22-0093-10 PCO#3

3333 Folkways Cir
Lincoln, NE 68504
(402) 475-9151
FAX (402) 475-9186



To: B-D Construction Attn: Bryan Kearney	Phone: 402-564-1225	Fax: -	Date: 8/29/22
	Job Name/Location: Columbus Fire Station #2 Columbus, NE		

Change is per PR#6 & FWA#2. Provide 1" conduits to floor boxes for future data cabling. See attached breakdown.

Notes

- 1) **MATERIAL PROCUREMENT NOR INSTALLATION WILL BEGIN UNTIL A FULLY EXECUTED CHANGE ORDER HAS BEEN RECEIVED BY KIDWELL.**
- 2) Change does not include any patching, painting, or repair of any surface.
- 3) All work to be completed during Kidwell's normal business hours.
- 4) Change will impact schedule, and require 0 business day(s) time extension.
- 5) No sales tax has been included for material and labor in this proposal.
- 6) All other required taxes will be charged and added to the proposal price on invoicing.

NOTE: This Proposed Change Order is only good for 10 days due to the rising cost of commodities.
NOTE: This Proposed Change Order becomes part of and in conformance with the existing contract.

CONFIDENTIALITY NOTICE: *This proposal and/or change order and any attachments are strictly confidential and are intended solely for the use of the individual or entity to whom it is addressed. This communication may contain proprietary and financial data of Kidwell Inc. If you are not the intended recipient, be advised that any use, dissemination, forwarding, printing, or copying of this proposal and/or change order and any file attachments is strictly prohibited.*

We Agree hereby to make the change(s) specified above at this price **ADD \$1,039.00**
One Thousand Thirty-Nine Dollars and 00/100 Cents.

Proposed Change Order Prepared By: <u>Brian Mostek</u>	PREVIOUS CONTRACT AMOUNT:
Authorized Kidwell Representative Signature: _____ (CONTRACTOR)	REVISED CONTRACT AMOUNT:

Payment will be made as follows: **MONTHLY**
*Accounts not paid within thirty days are subject to a finance charge of 1% monthly, and an annual rate of 12%.

Accepted- The above prices and specifications of the Change Order are satisfactory and are hereby accepted. All work to be performed under same terms and conditions as specified in original contract unless otherwise stipulated.	Authorized Signature: _____ (OWNER)
	Date of Acceptance: _____

4) Labor

a) Total MH'S			6.60	
b) Paid Holiday's Factor			0.00	
c) Productivity Factor			0.00	
d) Height Adj. Factor			0.00	
e) Job Cond. Factor			0.00	
Adjusted MH'S			6.60	
f)	7	MH'S Field Staff	63.55	444.85
g)	1	MH'S Project Mgr.	85.05	85.05
h)	1	MH'S Superintendant	73.75	73.75
i) Sub-Total Labor			603.65	
j) Material Tax		0.00 %		0.00
Total Items a-j				603.65

5) Subcontracts

a)	
b)	
c)	
d)	
e)	
f)	
g)	

Total Cost Item 5	0.00
--------------------------	------

6) Other Costs

a)	
b)	
c)	
d)	
e)	

Total Cost Item 6	0.00
--------------------------	------

Total Cost Item 1 thru 6			\$898.95
Job Overhead Cost			
Add or deduct sheet			
Total Prime Cost			\$898.95
Overhead	10	%	\$89.90
Total Cost			\$988.85
Profit	5	%	\$49.44
Sub-Total Selling			\$1,038.29
Bond	0	%	\$0.00
Total Selling Price			\$1,039.00



110 Armour Rd
North Kansas City, MO 64116
p. 816.300.4101
wskfarch.com

PROPOSAL REQUEST

Proposal Request No.: **006 (SIX)**
Date: 08/19/2022
Project: Columbus Fire Station #2

Owner: City of Columbus, NE
To: Bryan Kearney
B-D Construction, Inc.

Project No.: 20023
Contract For: General Construction
Contract Dated: 05/16/2022

Please submit an itemized quotation for changes in the Contract Sum and/or Contract Time, if any, for the proposed modifications to the Contract Documents described herein.

THIS IS NOT A CHANGE ORDER, OR A DIRECTION TO PROCEED WITH THE WORK DESCRIBED HEREIN.

Description:

1. Sheet E2.01 – Add Conduit; Dayroom FB-1
 - a. Add (1) 1 1/4" conduit from each FB-1 to west wall (wall between Dayroom & Mech. Storage). Extend conduit up wall (stud space) to top of wall; extend into attic space to all for future data cable routing. Add pull strings between FB and top of conduit.

Attachments: None

Signed: Rick Kuhl
WSKF, Inc.



2154 E. 32nd Avenue
 Columbus, NE 68601
 (Phone) 402-564-1225
 (Fax) 402-564-9999

CHANGE ORDER PROPOSAL

NO.

009

PROJECT: Columbus Fire Station #2
COP NO.: 009

DATE QUOTED: 12/19/22

PROJECT NO.: 22-024

ARCH. PROJECT NO.: A-1588

TO: Rick Kuhl
 WSKF Architects Inc.
 110 Armour Road
 North Kansas City, MO 64116
 (Phone) 816.300.4101 (Fax) 816.300.4102

**DAYS ALLOWED
 FOR APPROVAL:**

EXPIRATION DATE: 12/19/22

**REQUESTED EXTENSION
 OF TIME IN DAYS:**

DESCRIPTION:

Wing wall added to East of casework at transition between new and existing wall construction on South wall of Kitchen

SUBCONTRACTORS / VENDORS	SUB / VENDOR WORK DESCRIPTION	AMOUNT:
Mueller & Schoepf Drywall	Metal Framing and Drywall	\$210.00

B-D Construction, Inc.	5% Markup on Sub Contractors	\$10.50
B-D Construction, Inc.	Project Manager COP Processing	\$125.00

APPROVAL

TOTAL FROM WORK BREAKDOWN PAGES

SUB SUBTOTAL: \$345.50

NAME: _____

BOND: 1.2% \$4.15

DATE: _____

\$0.00

SEND COPIES TO

\$0.00

B-D Construction, Inc., Bryan Kearney
 City of Columbus, Rick Bogus
 WSKF Architects Inc., Rick Kuhl

\$0.00

SUBTOTAL: \$349.65

B-D CONSTRUCTION, INC.

BY: Bryan L Kearney
 Bryan Kearney, Project Manager

SUBTOTAL: \$349.65

\$0.00

DATE: 12/19/22

TOTAL COP AMOUNT: \$349.65

Bryan Kearney

From: Mike Mueller <mueller2003@msn.com>
Sent: Monday, December 19, 2022 3:56 PM
To: Bryan Kearney
Subject: Re: Columbus Fire - PR 009

Labor and materials to frame, rock, bead, and finish wing wall for casework. Add: \$210.00

From: Bryan Kearney <bryank@bdconstructioninc.com>
Sent: Friday, December 16, 2022 4:26 PM
To: Mike Mueller <mueller2003@msn.com>
Cc: Kevin Rubeck- B-D Construction, Inc. <kevinrubeckbd@gmail.com>
Subject: FW: Columbus Fire - PR 009

Mike-

Attached is PR#09 for the Columbus Fire Station that adds a small wing wall to the kitchen casework, please respond with pricing.

Bryan Kearney
B-D Construction, Inc.
O: 402.564.1225 | C: 402.910.1306

From: Matt McCaffrey <MMcCaffrey@wskfarch.com>
Sent: Friday, December 16, 2022 6:20 AM
To: Bryan Kearney <bryank@bdconstructioninc.com>; Kevin Rubeck <kevinrubeckbd@gmail.com>
Cc: Rick Kuhl <RKuhl@wskfarch.com>
Subject: Columbus Fire - PR 009

Good morning Bryan_

Please see the attached PDF of PR 009. The purpose of this PR is to add in that wing wall at the wall thickness difference on the South wall of the Kitchen. Let me know if there are any questions. Thank you.

Matt McCaffrey
senior project designer / bim manager



North Kansas City, MO
816.300.4101
Kansas City, KS
913.287.1900



110 Armour Rd
North Kansas City, MO 64116
p. 816.300.4101
wskfarch.com

PROPOSAL REQUEST

Proposal Request No.: **009 (Nine)**
Date: 12/15/2022
Project: Columbus Fire Station #2

Owner: City of Columbus, NE
To: Bryan Kearney
B-D Construction, Inc.

Project No.: 20023
Contract For: General Construction
Contract Dated: 05/16/2022

Please submit an itemized quotation for changes in the Contract Sum and/or Contract Time, if any, for the proposed modifications to the Contract Documents described herein.

THIS IS NOT A CHANGE ORDER, OR A DIRECTION TO PROCEED WITH THE WORK DESCRIBED HEREIN.

Description:

1. Sheet A1.01 – Dimension Plan
 - a. Drawing A8 – First Floor Plan
 - i. Wing wall added to East of casework at transition between new and existing wall construction.
2. Sheet A1.02 – Keynote Plan
 - a. Drawing A8 – First Floor Plan
 - i. Wing wall added to East of casework at transition between new and existing wall construction.
3. Sheet A4.02 – Interior Elevations
 - a. Drawing A10 – Enlarged Plan – Kitchen
 - i. Wing wall added to East of casework.
 - b. Drawing F5 – Kitchen
 - i. Wing wall added to East of casework.
 - c. Drawing F10 – Kitchen
 - i. Wing wall added to East of casework.
4. Sheet A5.01 – Reflected Ceiling Plan
 - a. Drawing A9 – Reflected Ceiling Plan
 - i. Wing wall added to East of casework soffit.

Attachments: A1.01, A1.02, A4.02, A5.01

Signed: Matt McCaffrey
WSKF, Inc.

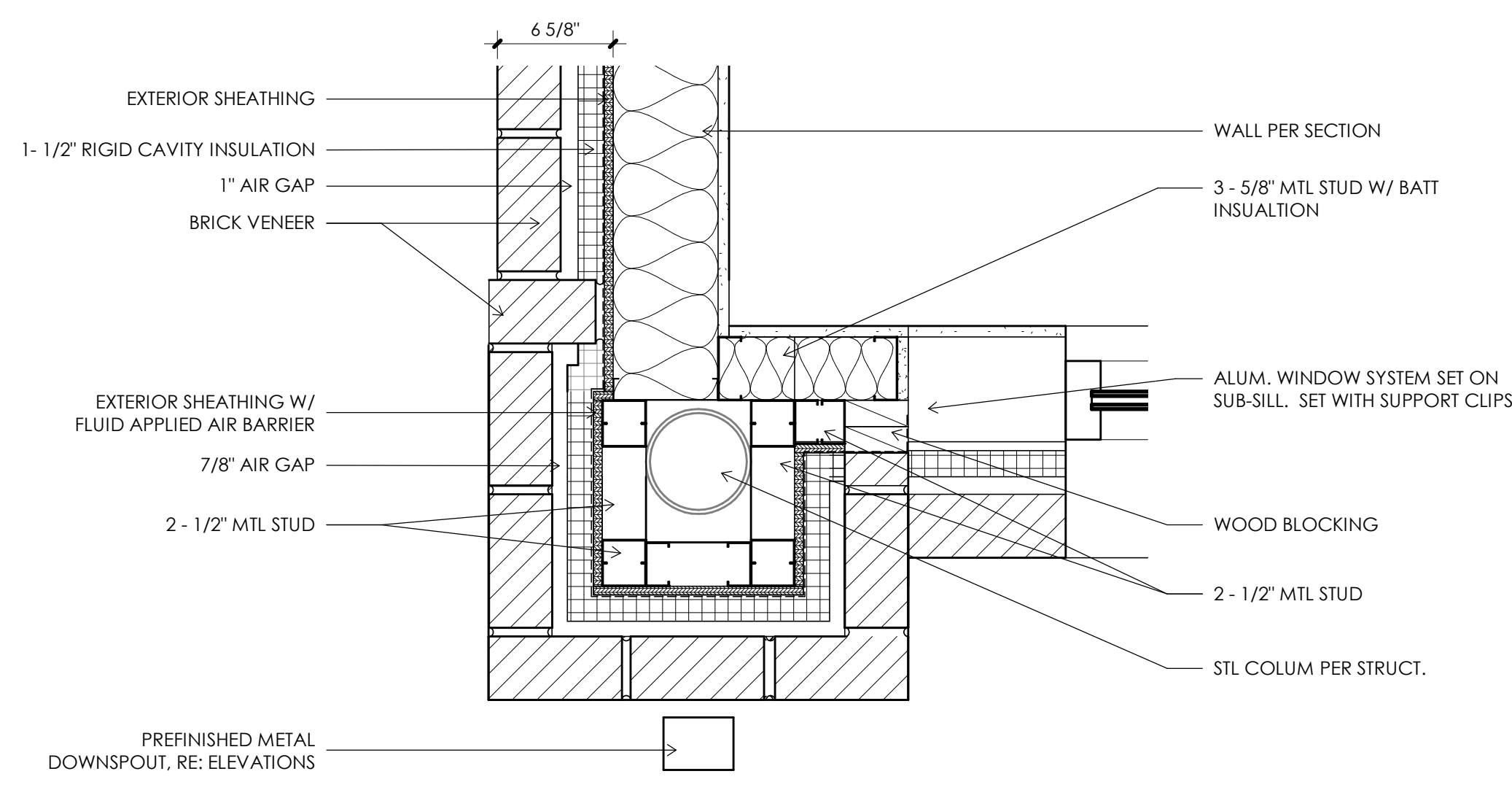

COLUMN WRAP PLAN
H5 DETAIL
1 1/2" = 1'-0"

PARTITION TYPE LEGEND:

BASIC MATERIAL:
 C CONCRETE (NON-STRUCTURAL WALLS ONLY)
 M MASONRY (CMU)
 S METAL STUD
 W WOOD STUD

NOMINAL SIZE:
 0 7/8" FURRING CHANNEL
 1 1 5/8" STUD
 2 2 1/2" STUD
 3 3 5/8" STUD
 4 4" CONCRETE, MASONRY OR 2X4 WOOD STUD
 6 6" CONCRETE, MASONRY OR 2X6 WOOD STUD
 8 8" CONCRETE, MASONRY
 10 10" CONCRETE, MASONRY
 12 12" CONCRETE, MASONRY

APPLIED LAYERS:
 A. 1 LAYER 5/8" DRYWALL / TILE BACKING PANEL
 B. 2 LAYERS 5/8" DRYWALL / TILE BACKING PANEL
 C. 1 LAYER 1/2" PLYWOOD

MODIFYING CONDITIONS:
 1. PARTIAL HEIGHT WALL 5'-4" TOP OF WALL.
 2. PROVIDE ACOUSTIC BATT INSULATION; FULL CAVITY WIDTH AND FULL WALL HEIGHT.
 3. COMPLETE WALL ASSEMBLY EXTENDS TO 6" ABOVE ADJOINING CEILING. BRACE WALL AS REQUIRED.
 4. 1 HR FIRE PARTITION - UL U432. ASSEMBLY TO BOTTOM OF ROOF SHEATHING.
 5. NOT USED.

GENERAL NOTES:
 1. ALL INTERIOR WALL TYPES ARE S3AA.2 UNLESS NOTED OTHERWISE.
 2. COMPLETE WALL ASSEMBLY IS CONTINUOUS TO BOTTOM OF ROOF DECK OR BOTTOM OF ASSEMBLY ABOVE UNLESS CHANGED BY MODIFYING CONDITION.
 3. PROVIDE TILE BACKER BOARD WHERE REQUIRED AS SUBSTRATE FOR FINISHES. REFER TO FINISH SCHEDULE FOR WALL FINISH AND SPECIFICATIONS.
 4. PROVIDE MOISTURE RESISTANT DRYWALL PER FINISH SCHEDULE AND SPECIFICATIONS.
 5. REFER TO STRUCTURAL DETAILS FOR MASONRY REQUIREMENTS.
 6. THE PARTITION CONSTRUCTION WILL MAINTAIN ITS DESIGNATION TO THE POINT OF AN INTERSECTING WALL. IF NO CHANGE IN DESIGNATION IS SHOWN BEYOND THE INTERSECTION, THE PREVIOUS PARTITION DESIGNATION APPLIES TO BOTH.
 7. ALL CORRIDORS TO RECEIVE ABUSE RESISTANT DRYWALL TO 4'-0" A.F.F.
 8. REFERENCE ENLARGED PLANS FOR ADDITIONAL PARTITION CALL OUTS.
 9. INTERIOR PLYWOOD SHEATHING TO BE AC GRADE WITH ALL FACES AND EDGES PRIMED AND FINISH PAINT SYSTEM ON EXPOSED FACE.

PARTITION TYPE SYMBOL:

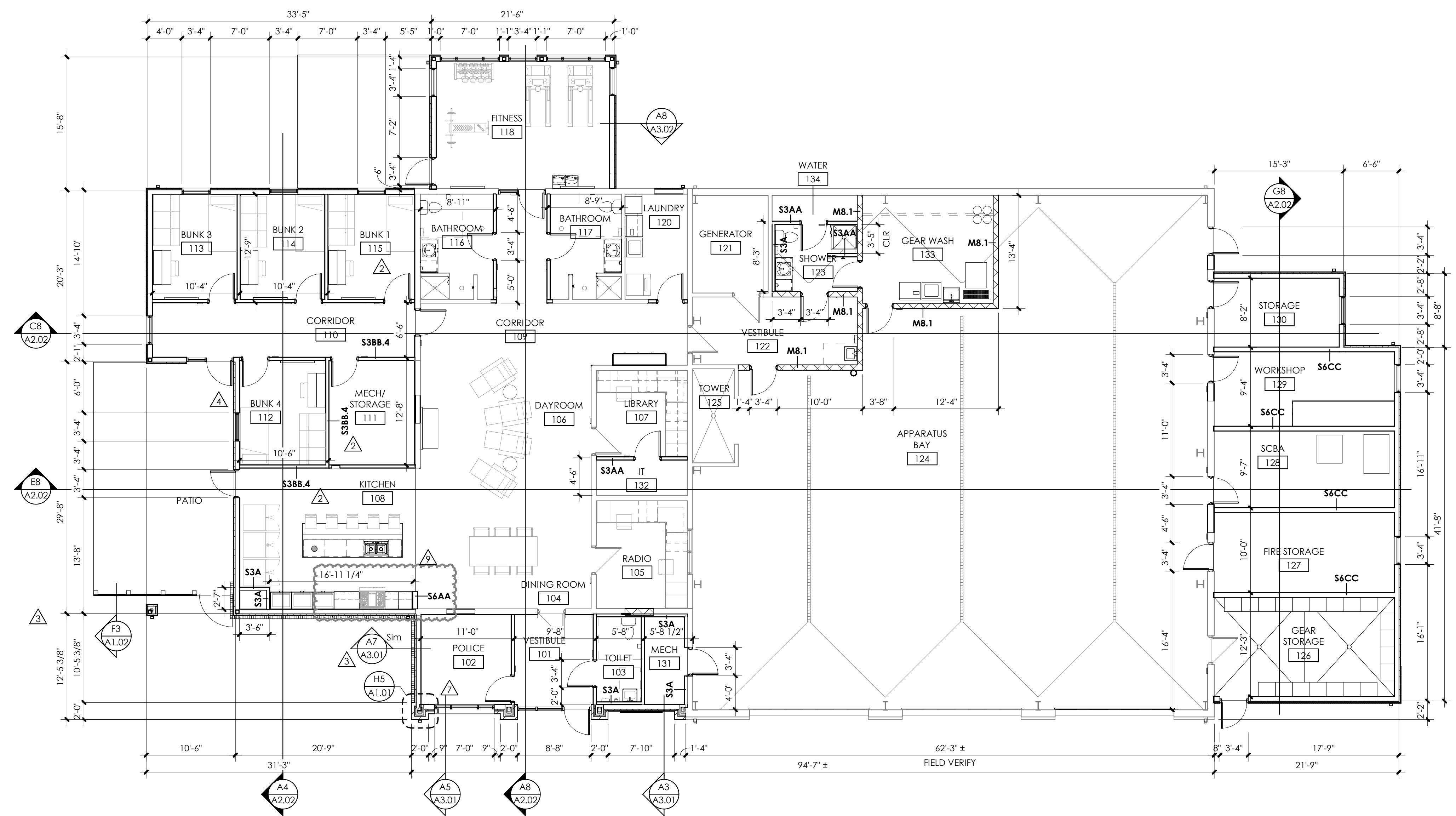
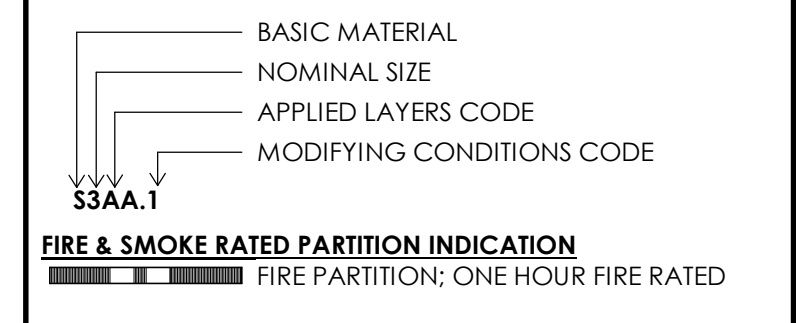

A8 FIRST FLOOR PLAN
1/8" = 1'-0"



Nebraska Certificate of Authority #CA4038
 Civil Engineer
 Gilmore & Associates
 State Certificate of Authority #000000000
 2670 33rd Avenue
 Columbus, NE 68601
 402-564-2807
 Structural Engineer
 Bob D. Campbell & Co.
 State Certificate of Authority #000000000
 4338 Bellevue
 Kansas City, MO 64111
 816-531-4144
 MEP Engineer
 PKMR Engineers, LLC
 State Certificate of Authority #000000000
 13300 W. 98th Street
 Lenexa, KS 66215
 913-342-2400

JOB NUMBER 20023

STATION #2 RENOVATION/EXPANSION

424 8TH STREET
 COLUMBUS, NE 68601
 CITY OF COLUMBUS, NE
 110 Armour Road North Kansas City, Missouri 64116 Tel: 816.300.4101 Fax: 816.300.4102

Richard A. Kuhl - Architect
 NE # A-1588

PERMIT DOCUMENTS

ISSUE DATE	03/09/2022	
No	Description	Date
1	ADD002	03/25/2022
2	ADD003	04/06/2022
3	ASI 001	06/21/2022
4	PRO04	07/26/2022
7	ASIO02	11/14/2022
9	PRO09	12/15/2022

WSKF, Inc. © 2022

DIMENSION PLAN

A1.01

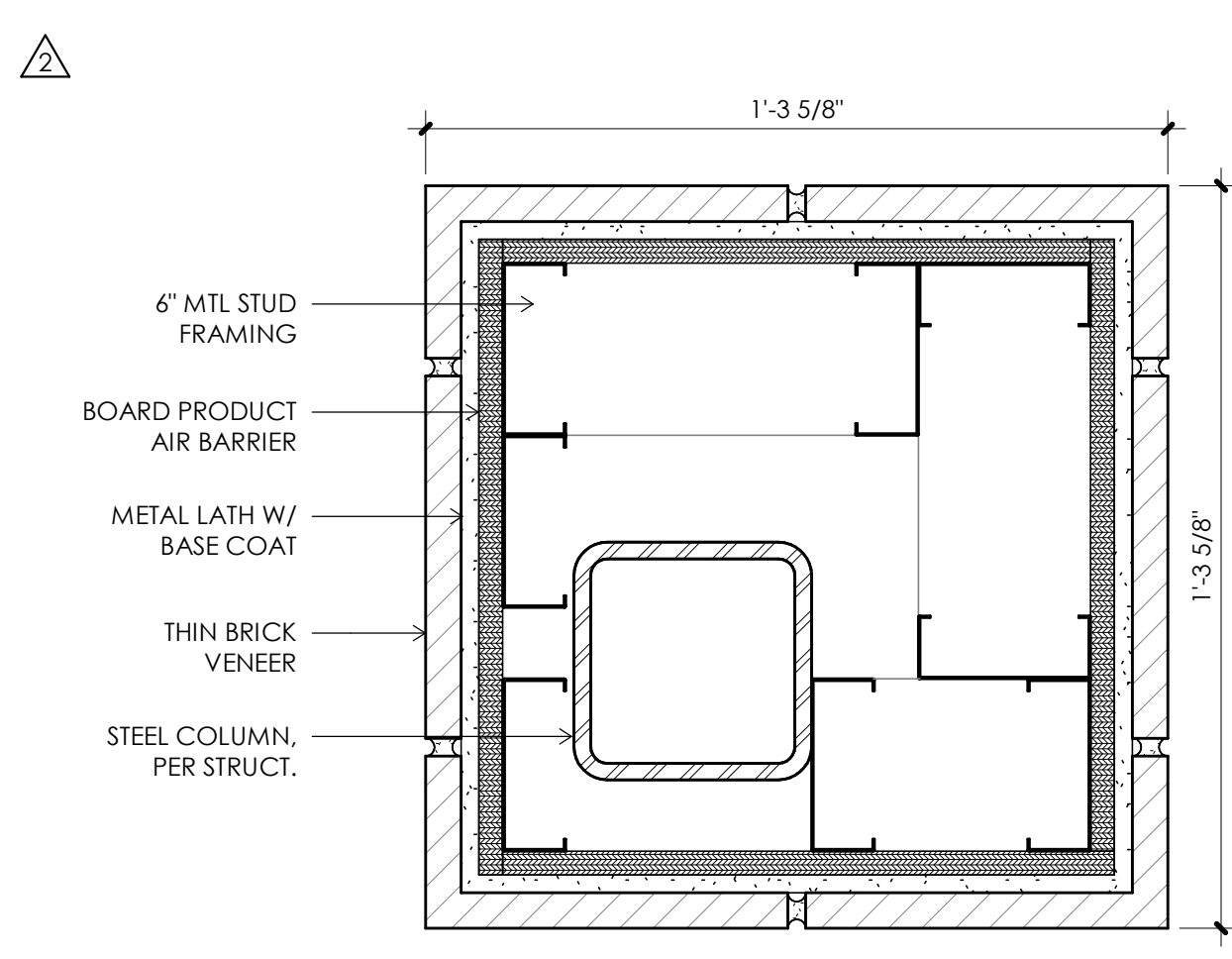

G5 COLUMN DETAIL
3/4" = 1'-0"

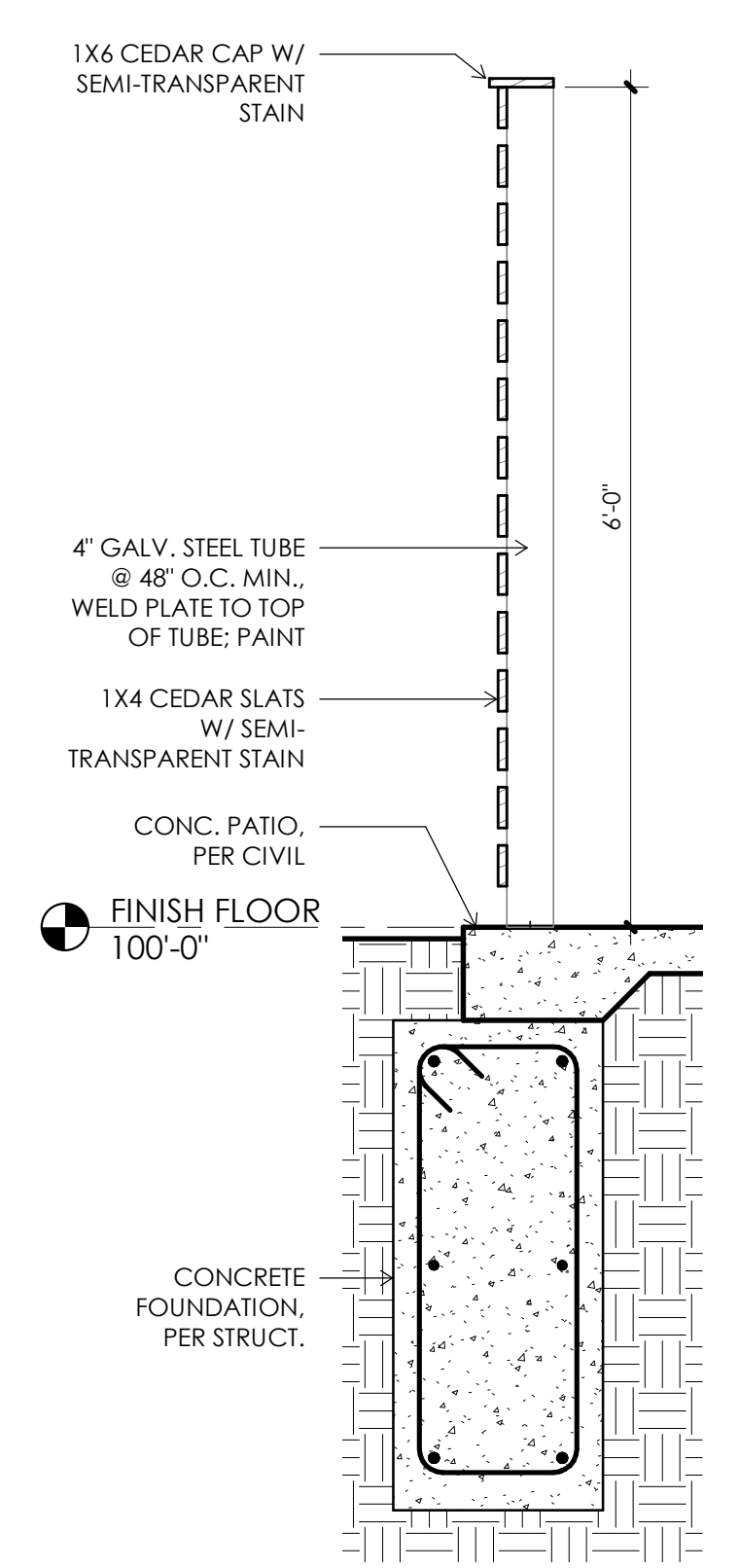

F3 PATIO FENCE DETAIL
3/4" = 1'-0"

GENERAL NOTES:

- CONTRACTOR SHALL BE RESPONSIBLE FOR VERIFYING ALL DIMENSIONS AND EXISTING CONDITIONS. ANY DISCREPANCIES WHICH WILL PREVENT THE ACCOMPLISHMENT OF INTENT SHOWN ON DRAWINGS SHALL BE BROUGHT TO THE IMMEDIATE ATTENTION OF THE ARCHITECT.
- WHERE A CONDITION IS NOTED 'TYPICAL' (TYP.), IT IS UNDERSTOOD THAT ALL SIMILAR CONDITIONS BE CONSTRUCTED OF THE SAME MATERIALS AND/OR DIMENSIONS.
- ALL DIMENSIONS ARE TO FACE OF STUD, FACE OF CMU, FACE OF CONCRETE FOUNDATION WALL, OR CENTER OF STL. STRUCTURE, UNLESS NOTED OTHERWISE.
- ALL DOOR OPENINGS ARE TO BE LOCATED 4" FROM HINGE SIDE OF ADJACENT WALL UNLESS CENTERED IN ROOM OR NOTED OTHERWISE.
- COORDINATE ROOF AND FLOOR PENETRATIONS W/ MEP AND STRUCTURAL DRAWINGS.
- SIGNAGE SCHEDULE ON **A7.01** FOR INTERIOR WALL MOUNTED ADA SIGNAGE AND LOCATIONS.
- REFER TO ROOM FINISH SCHEDULE ON **A7.01** FOR INTERIOR FINISHES.
- REFER TO TYPICAL ADA FIXTURE MOUNTING GUIDE ON **A7.01**.
- REFER TO ENLARGED FLOOR PLANS FOR FURTHER INFORMATION ON PARTITION TYPE TAGS, DIMENSIONS, ETC.

PLAN NOTES:

- ADD 1 LAYER OF 5/8" TYPE 'X' GYPSUM WALLBOARD TO EXISTING SHEATHING AFTER REMOVAL OF EXTERIOR FINISH.
- INFILL WALL WITH CONSTRUCTION TO MATCH ADJACENT WALL AFTER REMOVAL OF DOOR/WINDOW.
- LOCATION FOR WALL MOUNTED TV. PROVIDE IN WALL BLOCKING, POWER & DATA AS REQUIRED. REFER TO **A7.04** FOR TYPICAL MOUNTING DETAIL. COORDINATE FINAL MOUNTING HEIGHT WITH OWNER.
- FIRE EXTINGUISHER CABINET/BACKET. REFER TO A0.01 FOR FURTHER INFORMATION.
- METAL LOCKERS; REFER TO SPECIFICATIONS.
- EXISTING FLOOR DRAIN.
- DRINKING FOUNTAIN; REFER TO MEP FOR FURTHER INFORMATION.
- WASHER & DRYER. REFER TO MEP FOR FURTHER INFORMATION.
- EXTRACTOR; REFER TO MEP FOR FURTHER INFORMATION.
- STEEL ROD FOR HANGING STORAGE; REFER TO A7.04.
- TURNOUT GEAR LOCKERS.
- SCBA FILL STATION
- SCBA COMPRESSOR
- WORKBENCH; REFER TO A7.03.
- 6'-0" TALL CEDAR FENCE W/ SEMI-TRANSPARENT STAIN & 36" WIDE GATE. PROVIDE GATE WITH NECESSARY HARDWARE TO LATCH. SEE F3/A1.02.

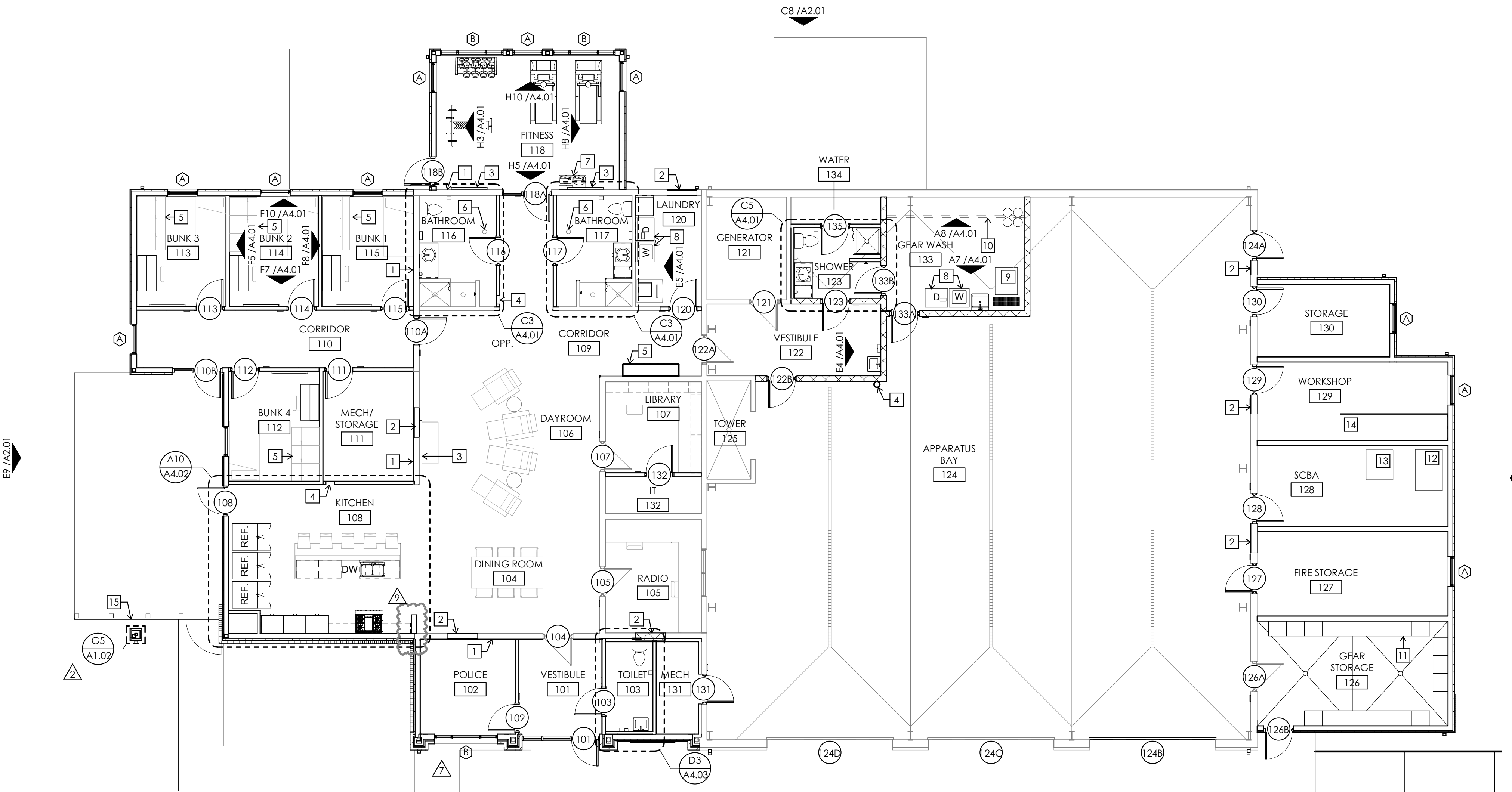

A8 FIRST FLOOR PLAN
1/8" = 1'-0"



Nebraska Certificate of Authority #CA4038

Civil Engineer
Gilmore & Associates
State Certificate of Authority #000000000
2670 33rd Avenue
Columbus, NE 68601
402-564-2807

Structural Engineer
Bob D. Campbell & Co.
State Certificate of Authority #000000000
4338 Bellevue
Kansas City, MO 64111
816-531-4144

MEP Engineer
PKMR Engineers, LLC
State Certificate of Authority #000000000
13300 W. 98th Street
Lenexa, KS 66215
913-342-2400

JOB NUMBER 20023

STATION #2 RENOVATION/EXPANSION

424 8TH STREET
COLUMBUS, NE 68601
CITY OF COLUMBUS, NE
110 Armour Road North Kansas City, Missouri 64116 Tel: 816.300.4101 Fax: 816.300.4102

Richard A. Kuhl - Architect
NE # A-1588

PERMIT DOCUMENTS

ISSUE DATE	03/09/2022	
No	Description	Date
1	ADD002	03/25/2022
2	ADD003	04/06/2022
7	AS1002	11/14/2022
9	PRO09	12/15/2022

WSKF, Inc. © 2022

KEYNOTE PLAN

A1.02

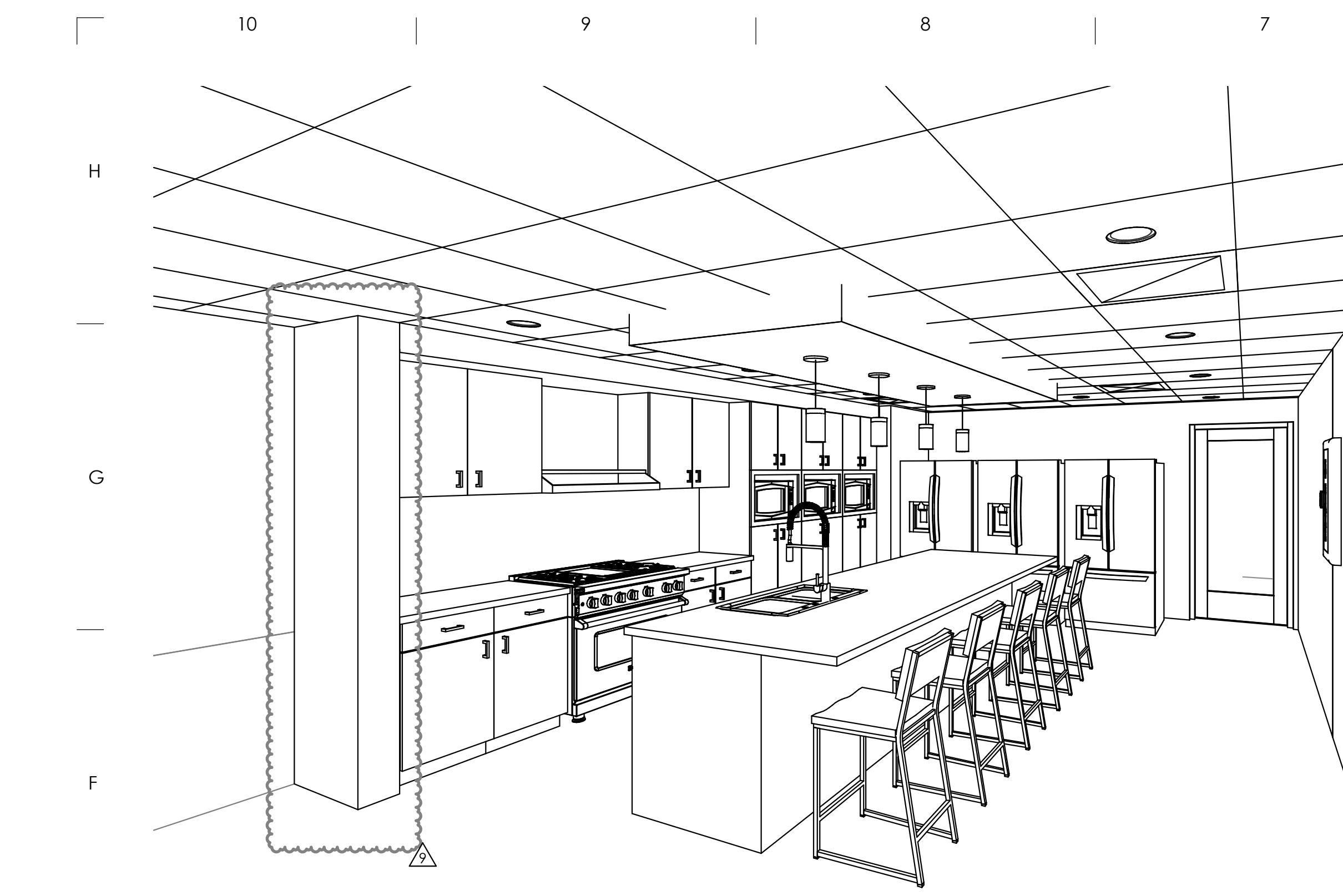

F10 KITCHEN

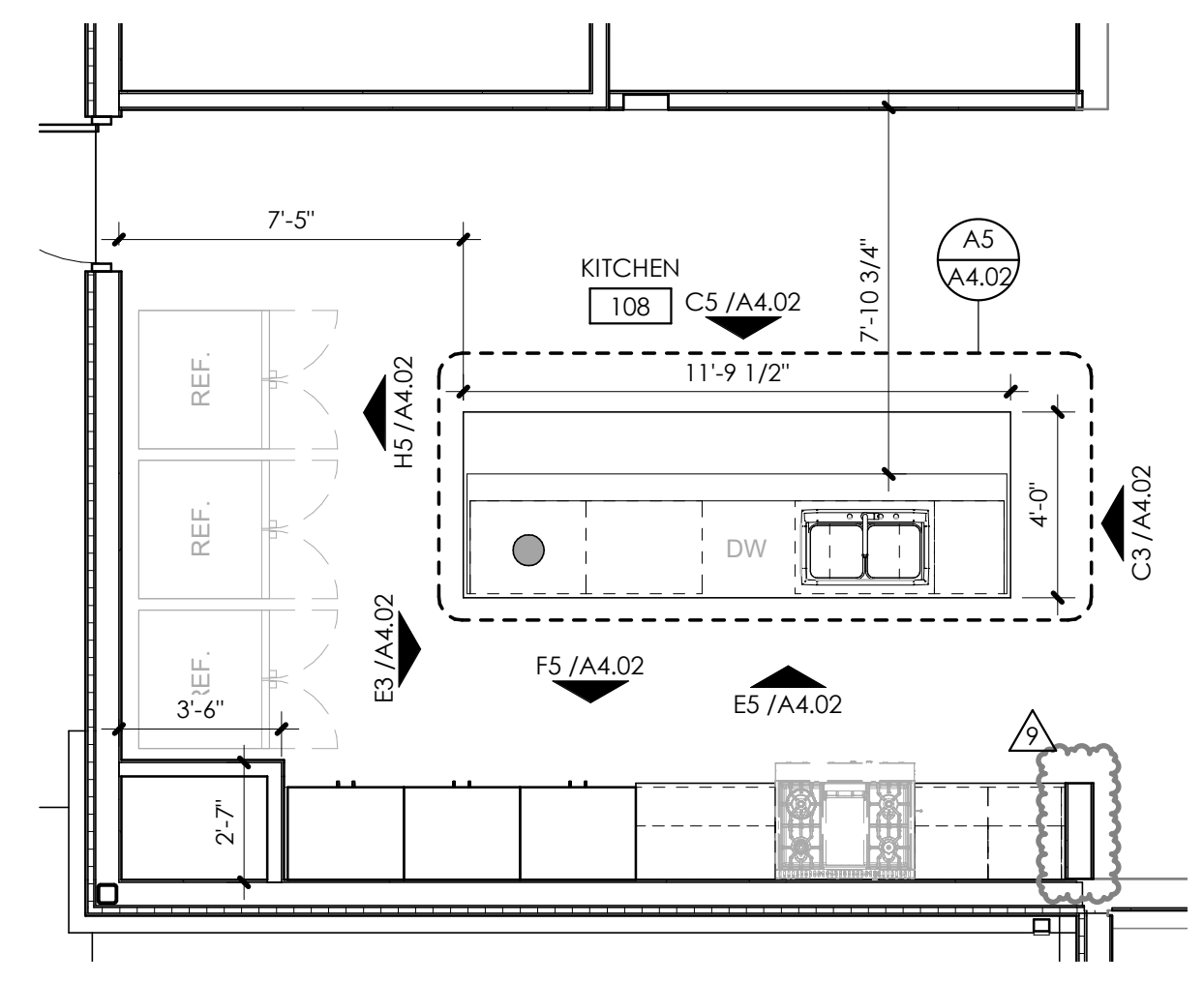

A10 ENLARGED PLAN - KITCHEN
1/4" = 1'-0"

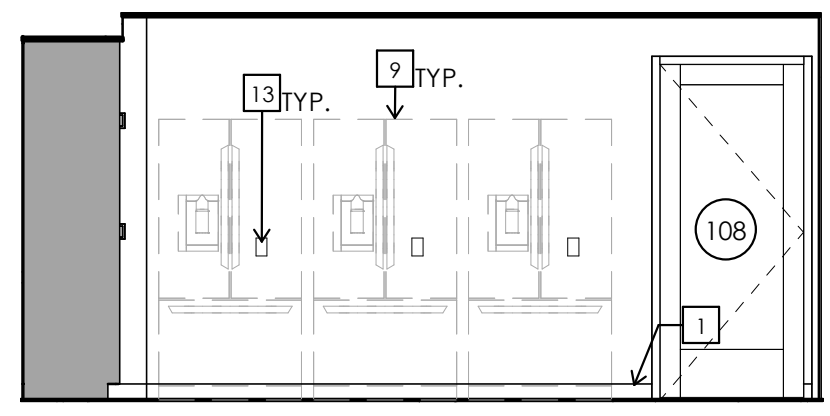

H5 KITCHEN
1/4" = 1'-0"

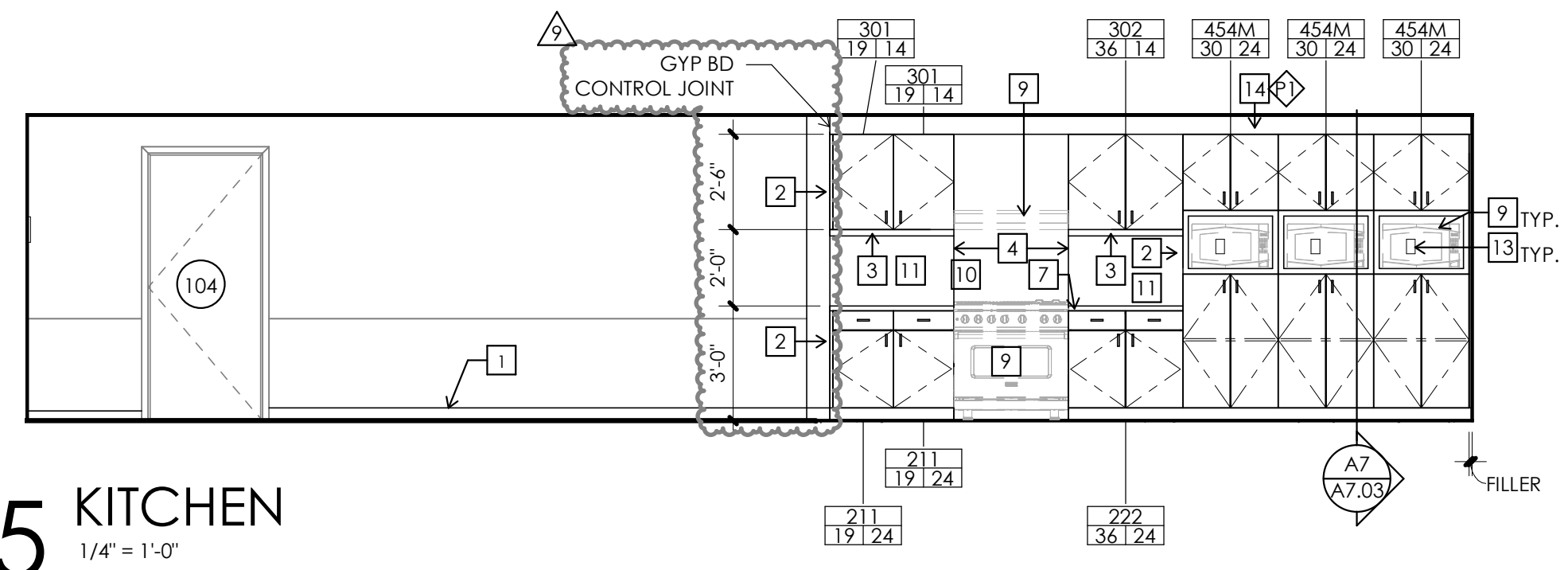

F5 KITCHEN
1/4" = 1'-0"

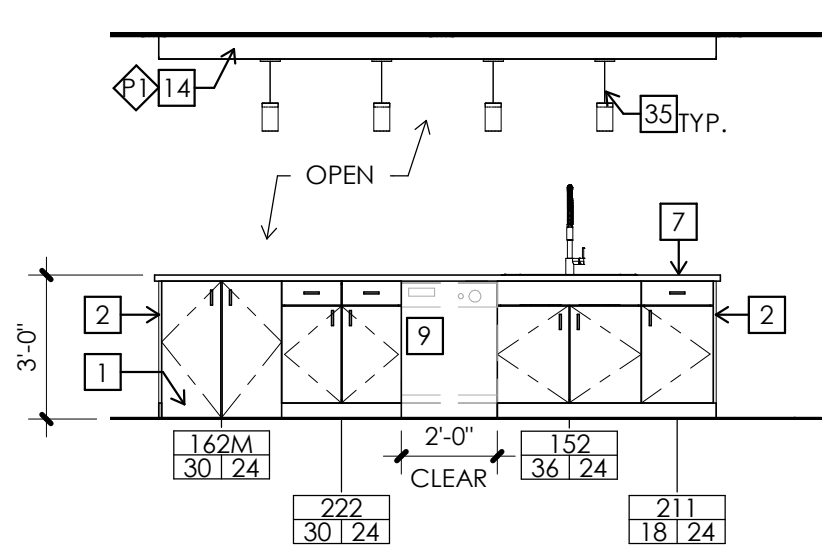

E5 KITCHEN ISLAND
1/4" = 1'-0"

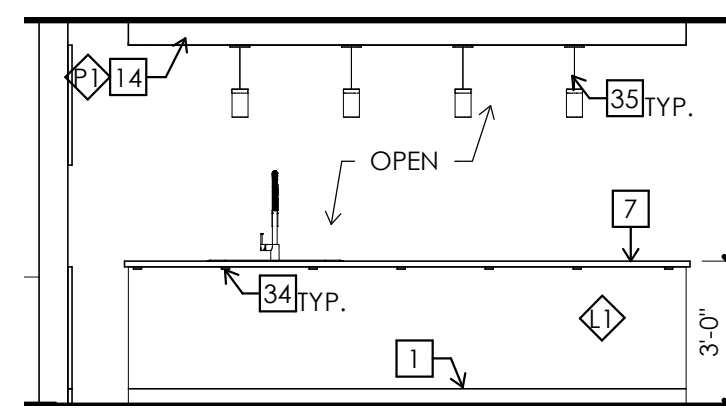

C5 KITCHEN ISLAND
1/4" = 1'-0"

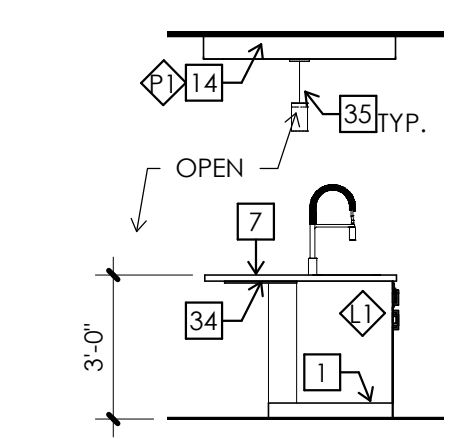

E3 KITCHEN ISLAND
1/4" = 1'-0"

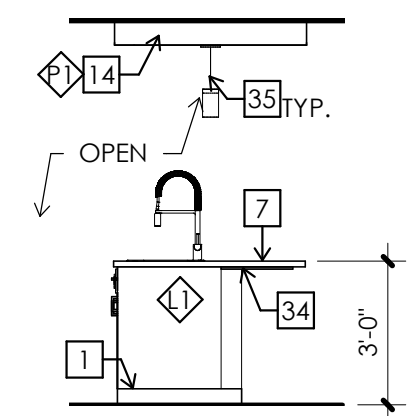

C3 KITCHEN ISLAND
1/4" = 1'-0"

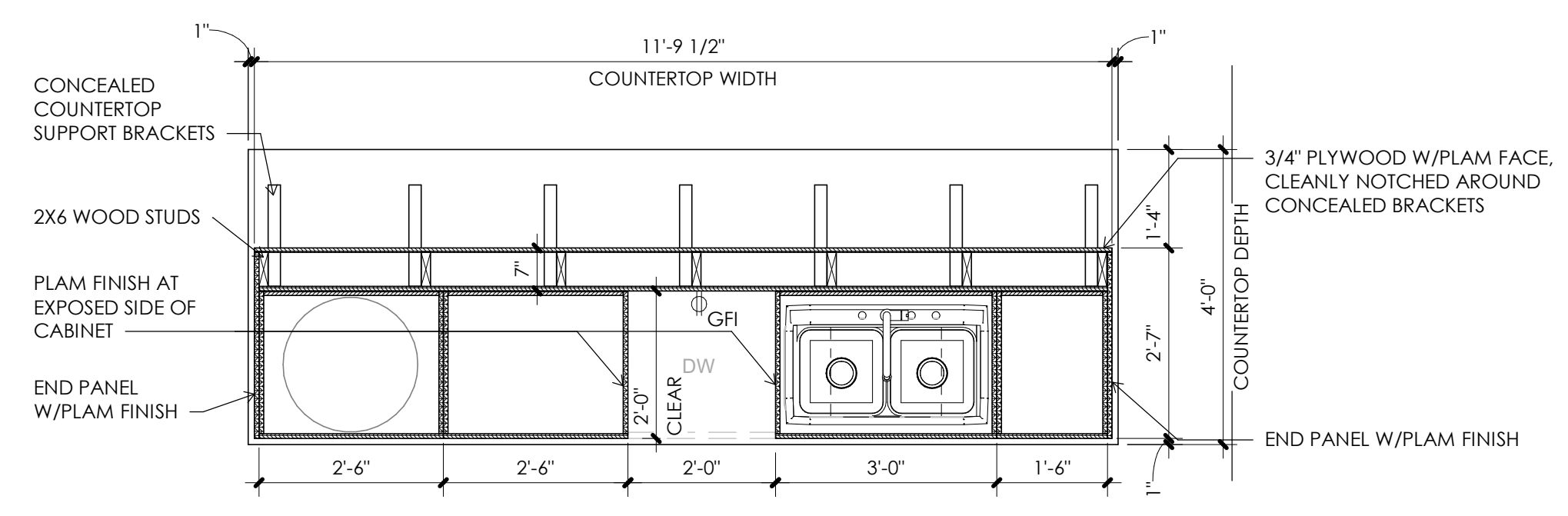

A5 ENLARGED PLAN - KITCHEN ISLAND
1/2" = 1'-0"

GENERAL NOTES:

- FOR ITEMS LABELED [1] REFER TO SPEC SECTION 102800 - TOILET, BATH, AND LAUNDRY ACCESSORIES.
 - FOR ITEMS LABELED [2] REFER TO FINISH SCHEDULE ON A7.01.
 - ALL DIMENSIONS ON INTERIOR ELEVATIONS ARE FROM FINISHED SURFACES.
 - OF=OWNER FURNISHED, OWNER INSTALLED.
 - OF=OWNER FURNISHED, CONTRACTOR INSTALLED.
 - REFER TO CASEWORK SCHEDULE ON A7.01 AND CASEWORK TAG, SEE BELOW.
- STANDARD AWI NUMBER "FILE" INDICATES DRAWER TO BE SIZED & OUTFITTED FOR HANGING FILES
CASEWORK DEPTH "I" INDICATES CABINET DOOR/DRAWER TO BE LOCKED
CASEWORK WIDTH

ELEVATION NOTES:

- WALL BASE PER FINISH SCHEDULE A7.01
- FINISHED END OF CASEWORK
- LIGHT VALANCE W/ UNDER CABINET LIGHT; RE:MEP. RETURN TO WALL @ FINISHED ENDS
- METAL TILE EDGE TRIM
- ROLLER SHADE PER ROLLER SHADE SCHEDULE ON A7.01
- CORNER GUARD; RE: FINISH LEGEND ON A7.01
- COUNTERTOP PER FINISH SCHEDULE
- COUNTERTOP & BACKSPLASH PER FINISH SCHEDULE
- APPLIANCE/EQUIPMENT, RE: FFE PLAN ON F1.01
- 18 GAUGE, BRUSHED 304, STAINLESS STEEL WALL CLADDING INSTALLED FROM FLOOR TO BOTTOM OF VENT HOOD. INSTALL ST. STL. J-TRIM @ ALL EXPOSED EDGES
- TILE BACKSPLASH; RE: FINISH SCHEDULE
- DATA; RE: MEP
- OUTLET; RE: MEP
- GYP. BD. SOFFIT; PAINT PER RCP ON A5.01
- MONITOR & MOUNTING BRACKET BY OWNER. CONTRACTOR TO PROVIDE 36" X 36" IN WALL SOLID BACKING; RE:TV MOUNTING GUIDE ON A7.04
- 24" WIDE METAL PERSONNEL LOCKERS; RE: A10/A7.04 FOR LOCKER CONFIGURATION
- HIGH IMPACT SHEET RUB RAIL, WP1; RE: FINISH LEGEND. COORDINATE FINAL MOUNTING HEIGHT W/ OWNER PROVIDED BEDFRAME
- WALL SCONCE; RE: MEP
- NOT USED
- TILE WAINSCOT; RE: E10/A7.04
- UTILITY SINK; RE: MEP
- NOT USED
- LATEX PAINT, P1, @ 10'-0" A.F.F. UP TO FINISHED CEILING
- FRAMELESS MIRROR; RE: SPEC
- 2" GROMMET - COORDINATE COLOR W/ ARCHITECT. COORDINATE FINAL LOCATION W/ OWNER
- VANITY LIGHT; RE: MEP
- COUNTERTOP BRACKET @ 24" O.C. MAX SPACING, U.N.O.
- INSULATED PIPE WRAP COVER; RE: MEP
- SCBA FILL STATION
- PLYWOOD COUNTERTOP ON STEEL SUPPORTS
- FINISHED END PANEL @ EXPOSED LOCKER END
- 8" STAINLESS STEEL ROUND TRASH GROMMET
- NOT USED
- CONCEALED COUNTERTOP SUPPORT BRACKET, NOTCH FINISH FACE OF WALL AROUND BRACKETS
- DECORATIVE PENDANT LIGHTING; RE: MEP
- INSTALL GARBAGE DISPOSAL SWITCH @ FILLER PANEL
- SWITCH FOR WALL SCONCE; RE: MEP
- EXISTING PLUG MOLD; RE: MEP
- MOCKET 8"X12" GT METAL AIR VENT GRILLE; LIGHT GRAY MESH/ 2
- NOT USED
- LOCKER FILLER PANEL TO CLOSE IN GAPS AT WALLS
- FIRE EXTINGUISHER; RE: CODE PLAN ON A0.01
- NOT USED
- DRYING CABINET
- EXTRACTOR
- MOCKETT SINGLE STORAGE DRAWER; RE: SPEC
- GEAR DRYING ROD; A3/A7.04
- DRINKING FOUNTAIN; RE: MEP
- LIGHT FIXTURE; RE: MEP
- 12" MULTI-TIERED PLAM LOCKERS; RE: SPEC
- SS. STL. NUMBER PLATES, # SEQUENCE TO BE 1, 2, 3.....; TOP TO BOTTOM, LEFT TO RIGHT



Nebraska Certificate of Authority #CA4038
Civil Engineer
Gilmore & Associates
State Certificate of Authority #000000000
2670 33rd Avenue
Columbus, NE 68601
402-564-2807

Structural Engineer
Bob D. Campbell & Co.
State Certificate of Authority #000000000
4338 Bellevue
Kansas City, MO 64111
816-531-4144

MEP Engineer
PKMR Engineers, LLC
State Certificate of Authority #000000000
13300 W. 98th Street
Lenexa, KS 66215
913-342-2400

JOB NUMBER 20023

STATION #2 RENOVATION/EXPANSION

424 8TH STREET
COLUMBUS, NE 68601

CITY OF COLUMBUS, NE
110 Armour Road North Kansas City, Missouri 64116 Tel: 816.300.4101 Fax: 816.300.4102

Richard A. Kuhl - Architect
NE # A-1588

PERMIT DOCUMENTS		
ISSUE DATE	Description	Date
03/09/2022	1	03/25/2022
	9	12/15/2022

WSKF, Inc. © 2022

INTERIOR ELEVATIONS

A4.02

12/14/2022 10:23:27 AM C:\Users\WmMcCauley\Desktop\Revit\2023_Charlie_Louis_Station_Expansion_CENTRAL_2022_mmcacaulley@wskfarch.com.rvt

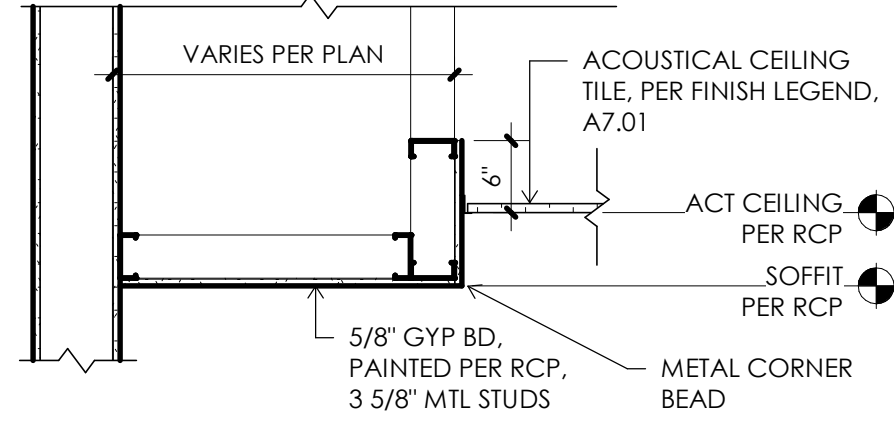

G10 SOFFIT DETAIL
3/4" = 1'-0"

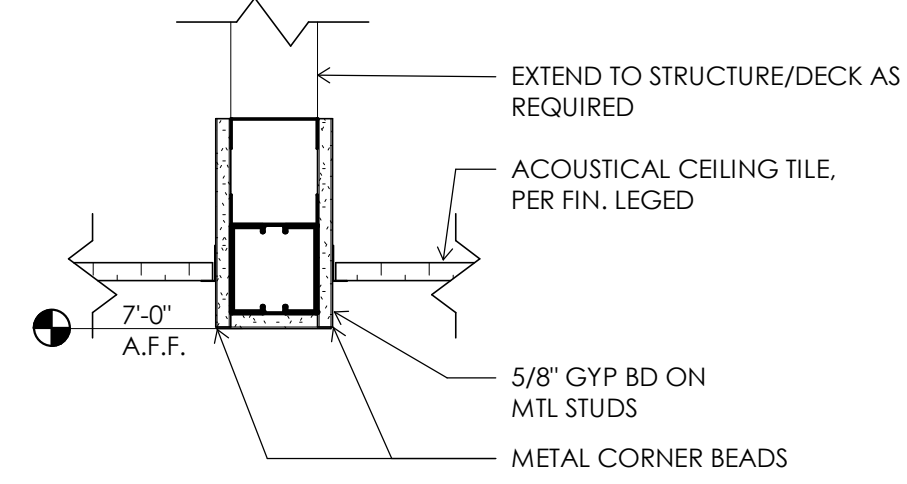

G7 GYP. BD. HEADER DETAIL
1 1/2" = 1'-0"

GENERAL NOTES:

1. ALL ACOUSTICAL CEILING TILES AND GRID TO BE INSTALLED @ 8'-0" A.F.F., U.N.O.
2. ALL GYP. BD. CEILINGS TO BE INSTALLED @ 9'-0" A.F.F. U.N.O.
3. RUN FRAMING FOR SOFFIT UP TO STRUCTURE W/ KICKERS @ 24" O.C. U.N.O.
4. REFER TO ELECTRICAL FOR LIGHT FIXTURE TYPES AND NOTES.
5. REFER TO MECHANICAL FOR SUPPLY AND RETURN REGISTER LOCATIONS.
6. PAINT ALL GYP. BD. CEILINGS & SOFFITS PER FINISH SCHEDULE.
7. PROVIDE ATTIC ACCESS LOCATIONS THROUGH EXISTING WALL/ROOF AS REQUIRED TO REACH ALL AREAS OF THE NEW CONSTRUCTION ATTIC.

RCP NOTES:

- 1 GYP. BD. INSTALLED AT BOTTOM OF STRUCTURE
- 2 BULKHEAD; RE: G7/A5.01
- 3 DECORATIVE VANITY FIXTURE ABOVE MIRROR
- 4 PROVIDE ATTIC ACCESS LOCATION IN GYPSUM BOARD @ BOTTOM OF TRUSS AT THIS LOCATION. COORDINATE LOCATION TO ALIGN WITH CEILING TILE BELOW.
- 5 SOFFIT PANEL AT EAVE TO BE VENTED. SPACE VENTED PANELS AS NEEDED TO PROVIDE REQUIRED NET FREE AREA PER 2018 IBC.

LEGEND:

- PAINTED GYP. BD CEILING PER FINISH LEGEND
- ACOUSTIC CEILING GRID & TILE (ACT 1) PER FINISH LEGEND

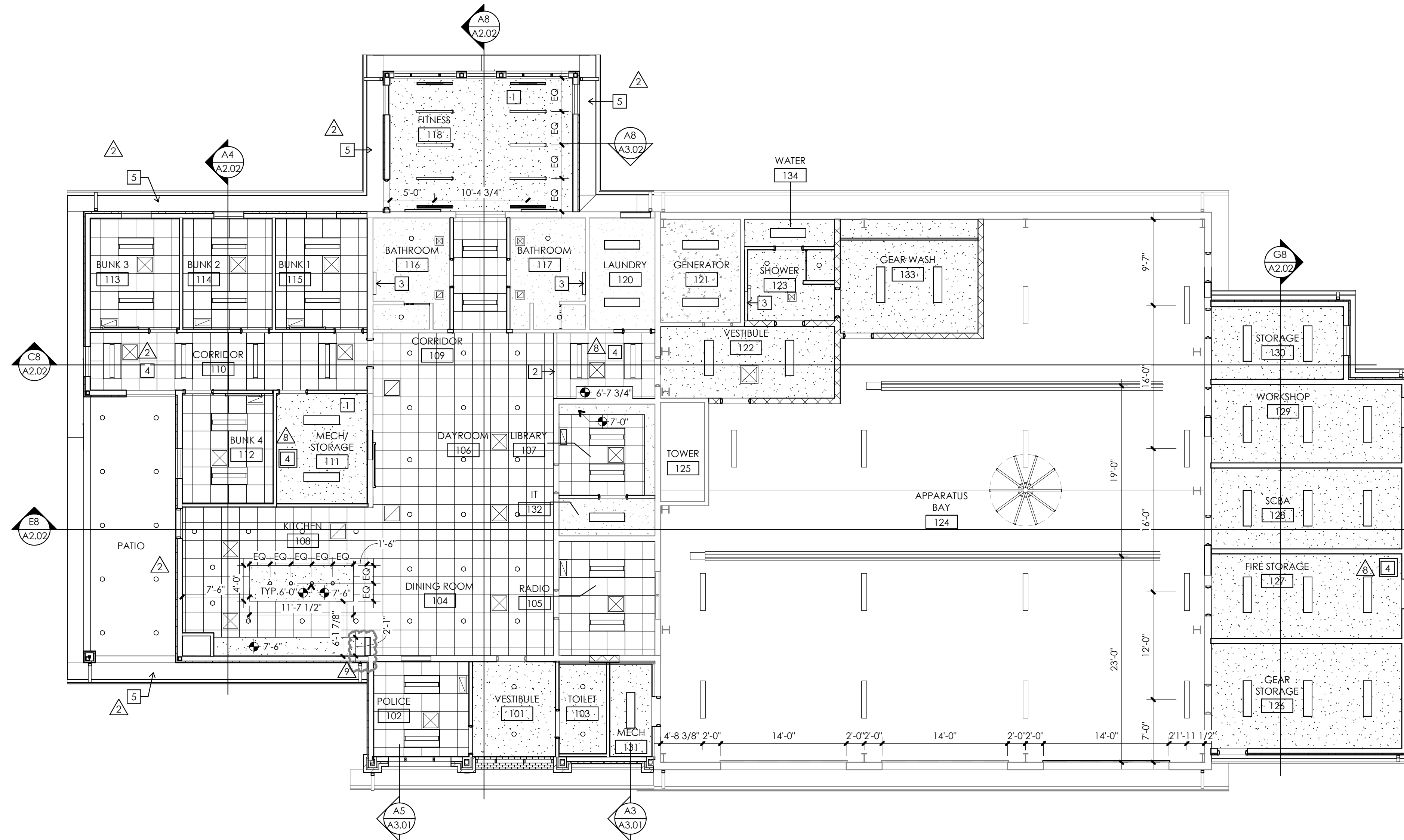

A9 REFLECTED CEILING PLAN
1/8" = 1'-0"



Nebraska Certificate of Authority #CA4038

Civil Engineer
Gilmore & Associates
State Certificate of Authority #000000000
2670 33rd Avenue
Columbus, NE 68601
402-564-2807

Structural Engineer
Bob D. Campbell & Co.
State Certificate of Authority #000000000
4338 Bellevue
Kansas City, MO 64111
816-531-4144

MEP Engineer
PKMR Engineers, LLC
State Certificate of Authority #000000000
13300 W. 98th Street
Lenexa, KS 66215
913-342-2400

JOB NUMBER 20023

STATION #2 RENOVATION/EXPANSION

424 8TH STREET
COLUMBUS, NE 68601

CITY OF COLUMBUS, NE
110 Armour Road North Kansas City, Missouri 64116 Tel: 816.300.4101 Fax: 816.300.4102

Richard A. Kuhl - Architect
NE # A-1588

PERMIT DOCUMENTS	
ISSUE DATE	03/09/2022
No	Description
1	ADD002 03/25/2022
2	ADD003 04/06/2022
8	PRO08 11/15/2022
9	PRO09 12/15/2022

WSKF, Inc. © 2022

REFLECTED CEILING PLAN

A5.01



2154 E. 32nd Avenue
 Columbus, NE 68601
 (Phone) 402-564-1225
 (Fax) 402-564-9999

CHANGE ORDER PROPOSAL

NO. PR010

PROJECT: Columbus Fire Station #2
COP NO.: PR010 **DATE QUOTED:** 01/27/23

TO: Rick Kuhl
 WSKF Architects Inc.
 110 Armour Road
 North Kansas City, MO 64116
 (Phone) 816.300.4101 (Fax) 816.300.4102

PROJECT NO.: 22-024
ARCH. PROJECT NO.: A-1588

DAYS ALLOWED FOR APPROVAL:
EXPIRATION DATE: 01/27/23
REQUESTED EXTENSION OF TIME IN DAYS:

DESCRIPTION:

1. Provide credit to remove base cabinet to the right of the island sink. Install (2) 2" grommets in side of sink base cabinet to run power cord to outlet below sink and to run ice maker drain line to sink drain.
2. Show open space for under counter ice maker with filler panel
3. Updated framing detail to show 15" clear space for Owner Provided, Contractor installed under counter ice maker (provide price to install). Overhang to be kept to 1" in front of the sink. Revise wall framing to 2x4 studs at undercounter ice maker as shown on revised drawings.

SUBCONTRACTORS / VENDORS	SUB / VENDOR WORK DESCRIPTION	AMOUNT:
HWI Custome Interiors	Casework	\$0.00
Obrist & Co.	Ice Maker Install	\$215.00
B-D Construction, Inc.	5% Mark Up on Subcontractors	\$10.75
B-D Construction, Inc.	Project Manager COP Processing	\$125.00

APPROVAL

TOTAL FROM WORK BREAKDOWN PAGES

NAME: _____	SUB SUBTOTAL:	\$350.75
DATE: _____	BOND: 1.2%	\$4.21
SEND COPIES TO		\$0.00
B-D Construction, Inc., Bryan Kearney		\$0.00
WSKF Architects Inc., Rick Kuhl		
City of Columbus, Rick Bogus	SUBTOTAL:	\$354.96
B-D CONSTRUCTION, INC.		
BY: <i>Bryan L. Kearney</i>	SUBTOTAL:	\$354.96
Bryan Kearney, Project Manager		\$0.00
DATE: 1/27/23	TOTAL COP AMOUNT:	\$354.96



P O Box 581
Columbus, NE 68602-0581
402-564-2804
402-562-7950 Fax

3-10-23

PR #10 To install owners ice maker.

Labor \$150.00

Material \$65.00.

Total \$ \$215.00

Br

Thanks,
John

Bryan Kearney

From: Becky Carmichael <beckyc@hwicustominteriors.com>
Sent: Friday, January 27, 2023 9:39 AM
To: Bryan Kearney
Subject: RE: Columbus Fire Station #2 - PR 10

Bryan,

There will be no credit for the cabinet that is being taken out. We have the material already ordered and the birch drawers are already made. Let me know if you have any questions. Thank you.

Regards,

Becky Carmichael

HWICustomInteriors

1406 7th Ave | Council Bluffs, IA 51501
P: 712.890.0085 | www.hwicustominteriors.com

From: Bryan Kearney <bryank@bdconstructioninc.com>
Sent: Thursday, January 26, 2023 3:34 PM
To: Randall Holt <Randallh@hwicustominteriors.com>; Becky Carmichael <beckyc@hwicustominteriors.com>
Cc: Brad Graham of B-D Construction, Inc. <brad@bdconstructioninc.com>; Kevin Rubeck- B-D Construction, Inc. <kevinrubeckbd@gmail.com>
Subject: FW: Columbus Fire Station #2 - PR 10

Becky-

See attached revision request for the Columbus Fire Station.

Please respond with pricing for this.

Bryan Kearney

B-D Construction, Inc.

O: 402.564.1225 | C: 402.910.1306

From: Matt McCaffrey <MMcCaffrey@wskfarch.com>
Sent: Thursday, January 26, 2023 2:21 PM
To: Bryan Kearney <bryank@bdconstructioninc.com>; Kevin Rubeck- B-D Construction, Inc. <kevinrubeckbd@gmail.com>
Subject: Columbus Fire Station #2 - PR 10

Bryan/Kevin_

Please see the attached PDF of PR 10. The purpose of this PR is to revise the kitchen island base cabinets for the owner provided undercounter ice maker. Review the attached and advise if there are any questions or needed clarification. Thank you.



110 Armour Rd
North Kansas City, MO 64116
p. 816.300.4101
wskfarch.com

PROPOSAL REQUEST

Proposal Request No.: **010 (Ten)**
Date: 01/25/2022
Project: Columbus Fire Station #2

Owner: City of Columbus, NE
To: Bryan Kearney
B-D Construction, Inc.

Project No.: 20023
Contract For: General Construction
Contract Dated: 05/16/2022

Please submit an itemized quotation for changes in the Contract Sum and/or Contract Time, if any, for the proposed modifications to the Contract Documents described herein.

THIS IS NOT A CHANGE ORDER, OR A DIRECTION TO PROCEED WITH THE WORK DESCRIBED HEREIN.

Description:

1. Sheet A4.02 – Interior Elevations
 - a. Drawing E5 – Elevation – Kitchen Island
 - i. Provide credit to remove base cabinet to the right of the island sink. Install (2) 2” grommets in side of sink base cabinet to run power cord to outlet below sink and to run ice maker drain line to sink drain.
 - b. Drawing A10 – Enlarged Plan – Kitchen
 - i. Show open space for under counter ice maker with filler panel
 - c. Drawing A5 – Enlarged Plan – Kitchen Island
 - i. Updated framing detail to show 15” clear space for Owner Provided, Contractor installed under counter ice maker (provide price to install). Overhang to be kept to 1” in front of the sink. Revise wall framing to 2x4 studs at undercounter ice maker as shown on revised drawings.

Attachments: A4.02

Signed: Lauren Cunningham
WSKF, Inc.

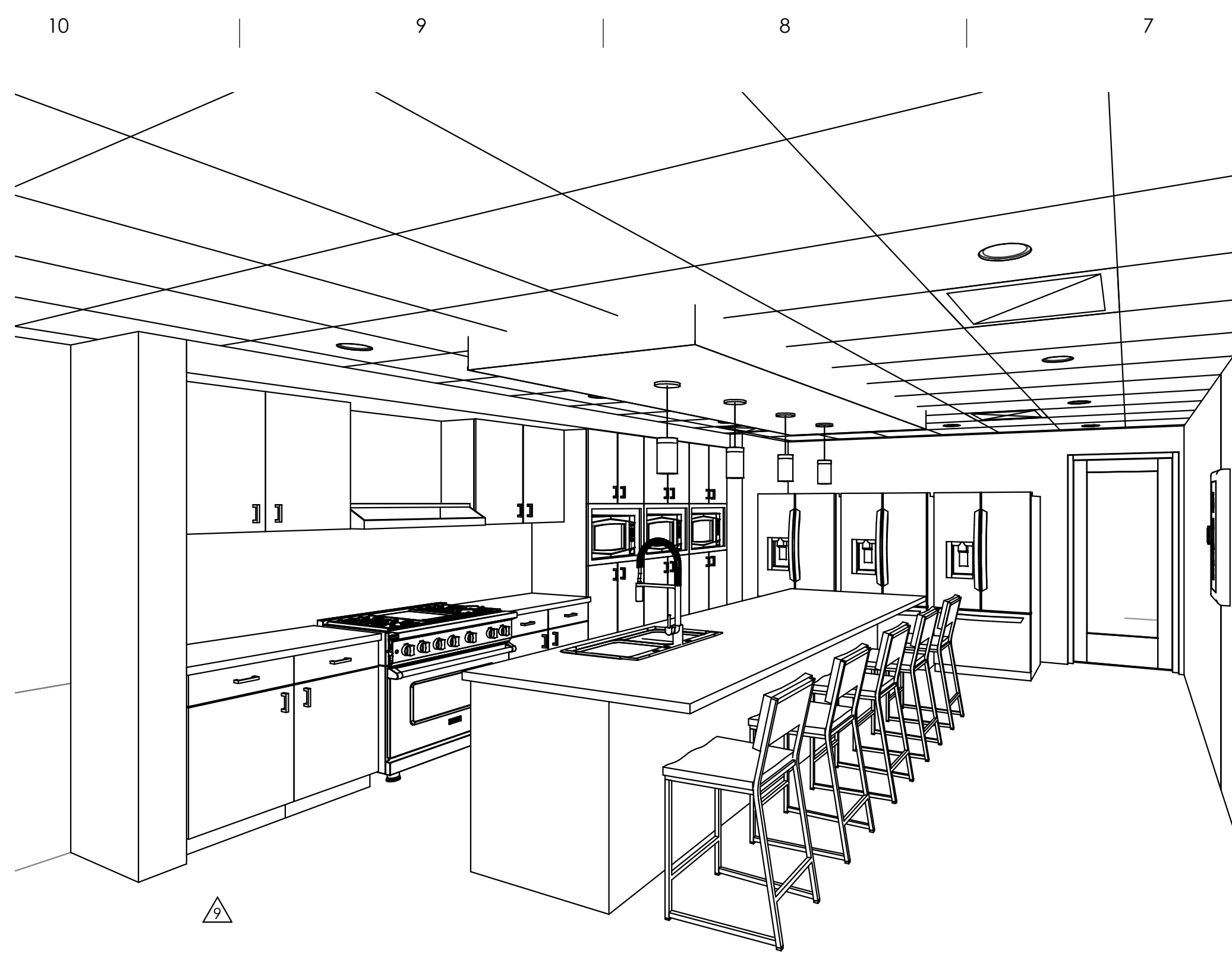

F10 KITCHEN

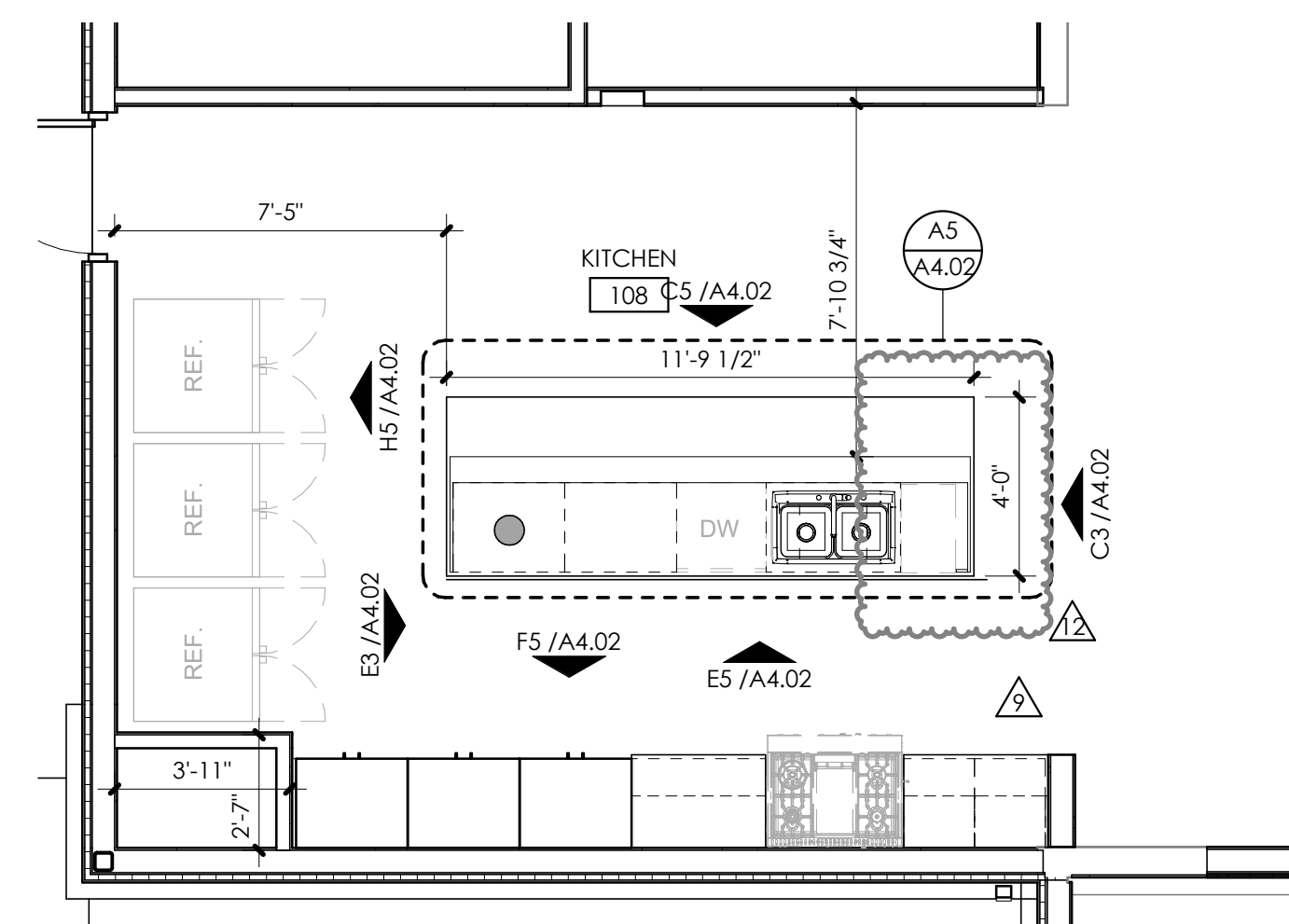

A10 ENLARGED PLAN - KITCHEN
1/4" = 1'-0"

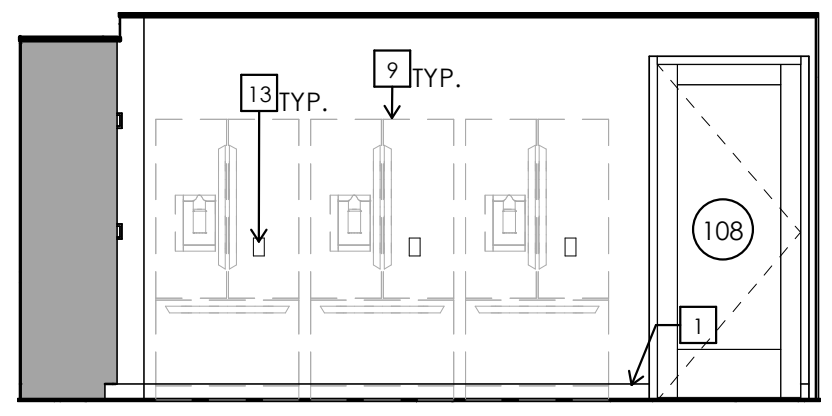

H5 KITCHEN
1/4" = 1'-0"

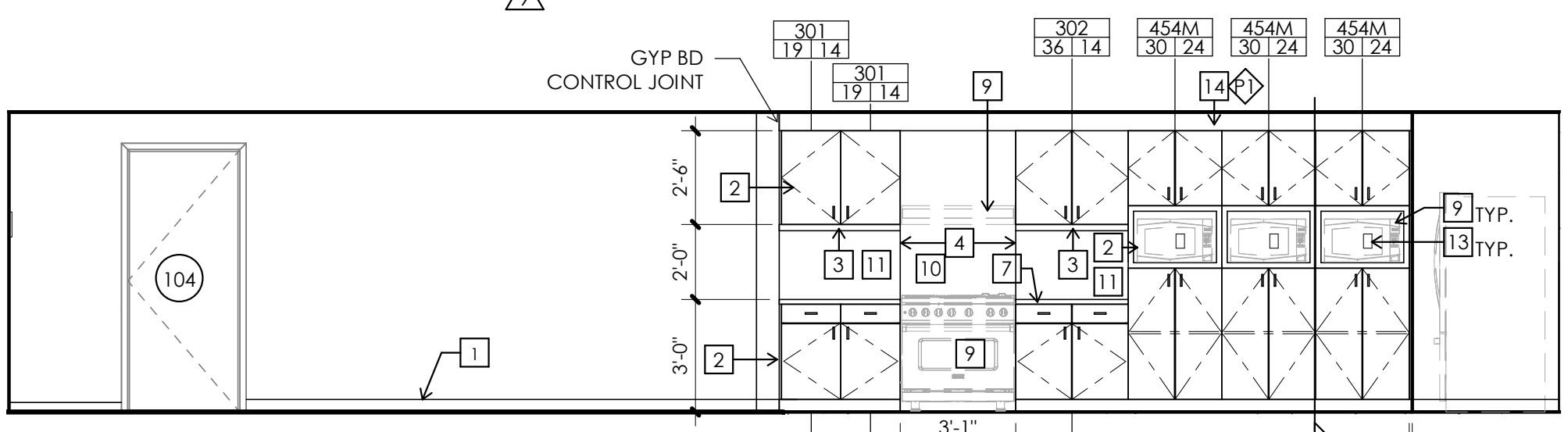

F5 KITCHEN
1/4" = 1'-0"

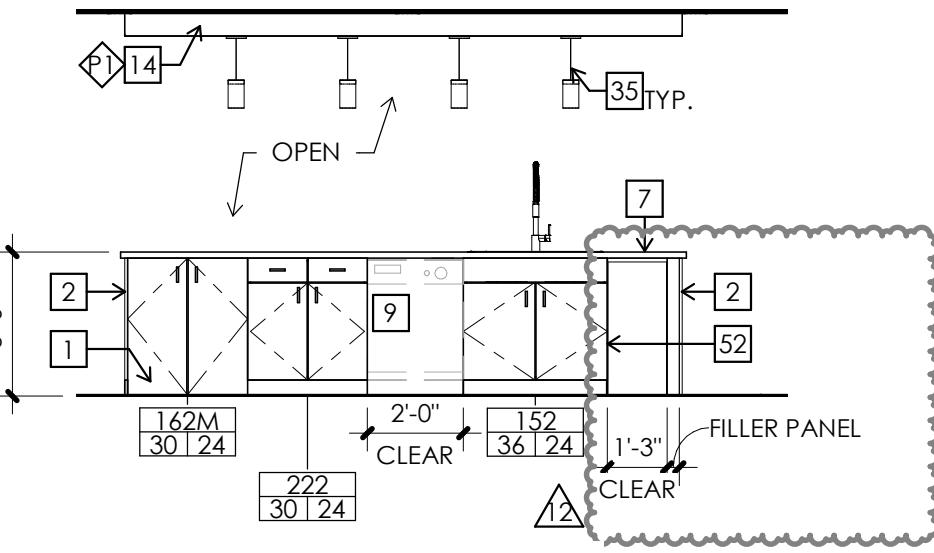

E5 KITCHEN ISLAND
1/4" = 1'-0"

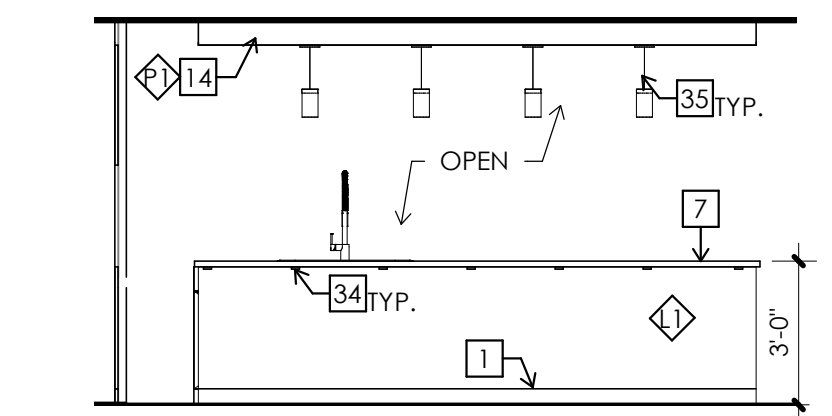

C5 KITCHEN ISLAND
1/4" = 1'-0"

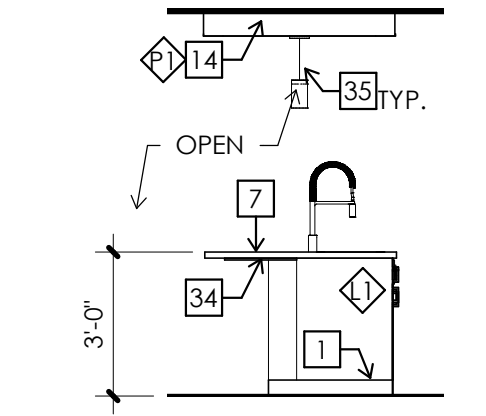

E3 KITCHEN ISLAND
1/4" = 1'-0"

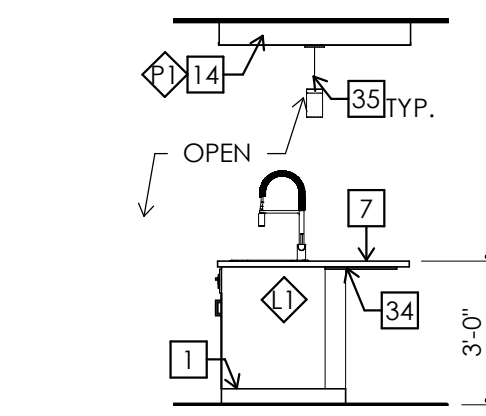

C3 KITCHEN ISLAND
1/4" = 1'-0"

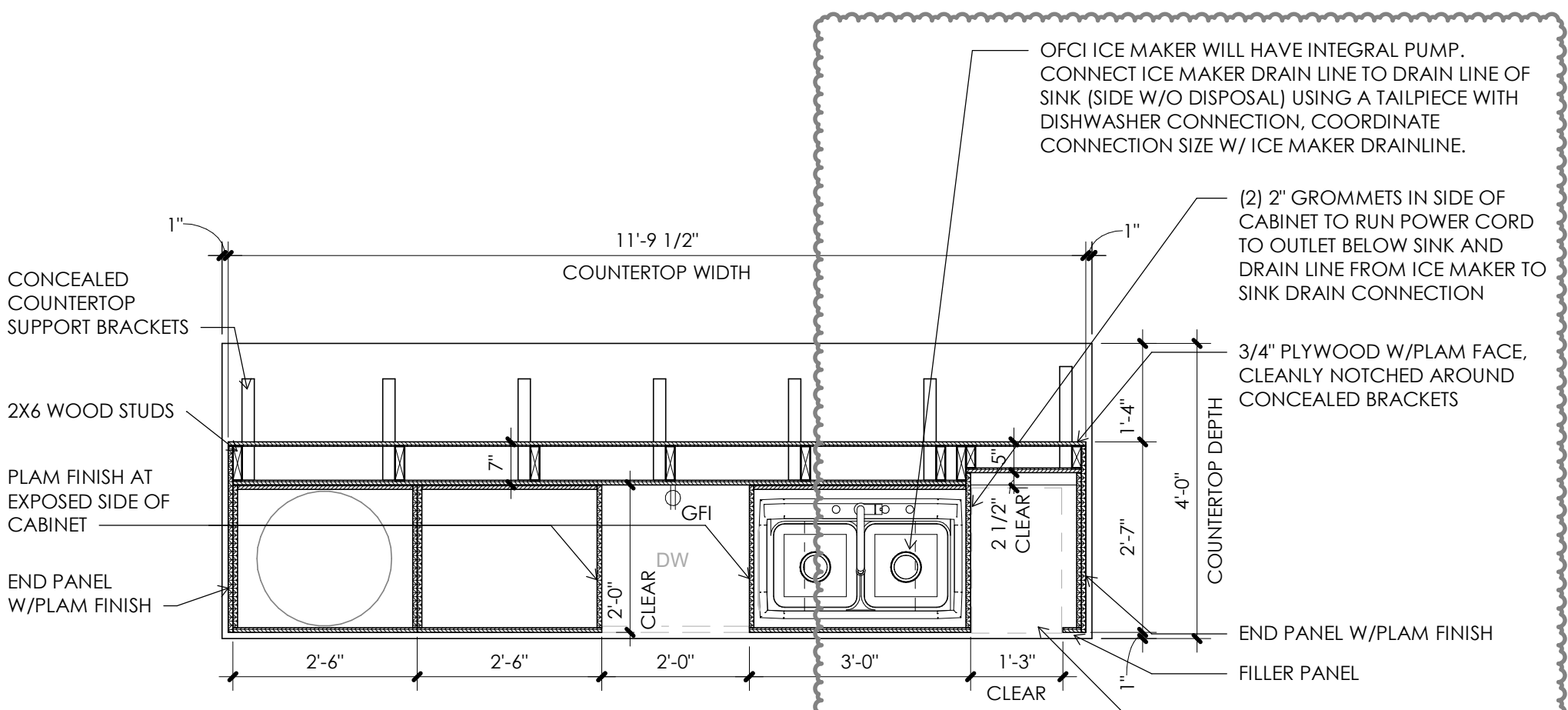

A5 ENLARGED PLAN - KITCHEN ISLAND
1/2" = 1'-0"

GENERAL NOTES:

- FOR ITEMS LABELED [1] REFER TO SPEC SECTION 102800 - TOILET, BATH, AND LAUNDRY ACCESSORIES.
 - FOR ITEMS LABELED [2] REFER TO FINISH SCHEDULE ON A7.01.
 - ALL DIMENSIONS ON INTERIOR ELEVATIONS ARE FROM FINISHED SURFACES.
 - OF= OWNER FURNISHED, OWNER INSTALLED.
 - OFCI= OWNER FURNISHED, CONTRACTOR INSTALLED.
 - REFER TO CASEWORK SCHEDULE ON A7.01 AND CASEWORK TAG, SEE BELOW.
- STANDARD AWI NUMBER: 60124
CASEWORK DEPTH: 60124
CASEWORK WIDTH: 60124
- "FILE" INDICATES DRAWER TO BE SIZED & OUTFITTED FOR HANGING FILES
"I" INDICATES CABINET DOOR/DRAWER TO BE LOCKED

ELEVATION NOTES:

- WALL BASE PER FINISH SCHEDULE A7.01
- FINISHED END OF CASEWORK
- LIGHT VALANCE W/ UNDER CABINET LIGHT; RE: MEP. RETURN TO WALL @ FINISHED ENDS
- METAL TILE EDGE TRIM
- ROLLER SHADE PER ROLLER SHADE SCHEDULE ON A7.01
- CORNER GUARD; RE: FINISH LEGEND ON A7.01
- COUNTERTOP PER FINISH SCHEDULE
- COUNTERTOP & BACKSPLASH PER FINISH SCHEDULE
- APPLIANCE/EQUIPMENT, RE: FFE PLAN ON F1.01
- 18 GAUGE, BRUSHED 304, STAINLESS STEEL WALL CLADDING INSTALLED FROM FLOOR TO BOTTOM OF VENT HOOD. INSTALL ST. STL. J-TRIM @ ALL EXPOSED EDGES
- TILE BACKSPLASH; RE: FINISH SCHEDULE
- DATA; RE: MEP
- OUTLET; RE: MEP
- GYP. BD. SOFFIT; PAINT PER RCP ON A5.01
- MONITOR & MOUNTING BRACKET BY OWNER. CONTRACTOR TO PROVIDE 36" X 36" IN WALL SOLID BACKING; RE: TV MOUNTING GUIDE ON A7.04
- 24" WIDE METAL PERSONNEL LOCKERS; RE: A10/A7.04 FOR LOCKER CONFIGURATION
- HIGH IMPACT SHEET RUB RAIL, WP1; RE: FINISH LEGEND. COORDINATE FINAL MOUNTING HEIGHT W/ OWNER PROVIDED BEDFRAME
- WALL SCONCE; RE: MEP
- NOT USED
- TILE WAINSCOT; RE: E10/A7.04
- UTILITY SINK; RE: MEP
- NOT USED
- LATEX PAINT, P1, @ 10'-0" A.F.F. UP TO FINISHED CEILING
- FRAMELESS MIRROR; RE: SPEC
- 2" GROMMET - COORDINATE COLOR W/ ARCHITECT. COORDINATE FINAL LOCATION W/ OWNER
- VANITY LIGHT; RE: MEP
- COUNTERTOP BRACKET @ 24" O.C. MAX SPACING, U.N.O.
- INSULATED PIPE WRAP COVER; RE: MEP
- SCBA FILL STATION
- PLYWOOD COUNTERTOP ON STEEL SUPPORTS
- FINISHED END PANEL @ EXPOSED LOCKER END
- 8" STAINLESS STEEL ROUND TRASH GROMMET
- NOT USED
- CONCEALED COUNTERTOP SUPPORT BRACKET, NOTCH FINISH FACE OF WALL AROUND BRACKETS
- DECORATIVE PENDANT LIGHTING; RE: MEP
- INSTALL GARBAGE DISPOSAL SWITCH @ FILLER PANEL
- SWITCH FOR WALL SCONCE; RE: MEP
- EXISTING PLUG MOLD; RE: MEP
- MOCKET 8"X12" GT METAL AIR VENT GRILLE; LIGHT GRAY MESH/ 2
- NOT USED
- LOCKER FILLER PANEL TO CLOSE IN GAPS AT WALLS
- FIRE EXTINGUISHER; RE: CODE PLAN ON A0.01
- NOT USED
- DRYING CABINET
- EXTRACTOR
- MOCKETT SINGLE STORAGE DRAWER; RE: SPEC
- GEAR DRYING ROD; A3/A7.04
- DRINKING FOUNTAIN; RE: MEP
- LIGHT FIXTURE; RE: MEP
- 12" MULTI-TIERED PLAM LOCKERS; RE: SPEC
- SS. STL. NUMBER PLATES, # SEQUENCE TO BE 1, 2, 3, ...; TOP TO BOTTOM, LEFT TO RIGHT
- INSTALL TWO GROMMETS IN SIDE OF SINK BASE CABINET; (1) FOR DRAIN LINE TO SINK DRAIN; (1) FOR POWER CORD TO RUN TO OUTLET BELOW SINK



Nebraska Certificate of Authority #CA4038
Civil Engineer
Gilmore & Associates
State Certificate of Authority #000000000
2670 33rd Avenue
Columbus, NE 68601
402-564-2807

Structural Engineer
Bob D. Campbell & Co.
State Certificate of Authority #000000000
4338 Bellevue
Kansas City, MO 64111
816-531-4144

MEP Engineer
PKMR Engineers, LLC
State Certificate of Authority #000000000
13300 W. 98th Street
Lenexa, KS 66215
913-342-2400

JOB NUMBER 20023

STATION #2 RENOVATION/EXPANSION

424 8TH STREET
COLUMBUS, NE 68601
CITY OF COLUMBUS, NE
110 Armour Road North Kansas City, Missouri 64116 Tel: 816.300.4101 Fax: 816.300.4102

Richard A. Kuhl - Architect
NE # A-1588

PERMIT DOCUMENTS		
ISSUE DATE	Description	Date
03/09/2022	No	
1	ADD002	03/25/2022
9	PRO09	12/15/2022
12	PRO10	01/25/2023

WSKF, Inc. © 2022

INTERIOR ELEVATIONS

A4.02

1/26/2023 1:36:34 PM C:\Users\WmMcCauley\Desktop\Revit\2023\Charlie_Louis_Station_Expansion_CENTRAL_2023_mmcacaulley@wskfarch.com.rvt



2154 E. 32nd Avenue
 Columbus, NE 68601
 (Phone) 402-564-1225
 (Fax) 402-564-9999

CHANGE ORDER PROPOSAL

NO. 012

PROJECT: Columbus Fire Station #2
COP NO.: 012

DATE QUOTED: 02/01/23

PROJECT NO.: 22-024

ARCH. PROJECT NO.: A-1588

TO: Rick Kuhl
 WSKF Architects Inc.
 110 Armour Road
 North Kansas City, MO 64116
 (Phone) 816.300.4101 (Fax) 816.300.4102

DAYS ALLOWED FOR APPROVAL:
EXPIRATION DATE: 02/01/23
REQUESTED EXTENSION OF TIME IN DAYS:

DESCRIPTION:

Replaced Additional Sidewalks and Pavement at front entrance on South Side of building to accomodate Sanitary Sewer tie in.

SUBCONTRACTORS / VENDORS	SUB / VENDOR WORK DESCRIPTION	AMOUNT:
Platte Valley Precast	Concrete Flatwork	\$3,700.00
B-D Construction, Inc.	5% Mark Up on Sub Contractors	\$178.27
B-D Construction, Inc.	Project Manager COP Processing	\$125.00

APPROVAL

TOTAL FROM WORK BREAKDOWN PAGES

NAME: _____
DATE: _____

SUB SUBTOTAL:	\$4,003.27
BOND: 1.2%	\$48.04
	\$0.00
	\$0.00
	\$0.00
SUBTOTAL:	\$4,051.31

SEND COPIES TO
 B-D Construction, Inc., Bryan Kearney
 WSKF Architects Inc., Rick Kuhl
 City of Columbus, Rick Bogus

B-D CONSTRUCTION, INC.

BY: *Bryan L. Kearney*
 Bryan Kearney, Project Manager

SUBTOTAL:	\$4,051.31
	\$0.00

DATE: 2/1/23

TOTAL COP AMOUNT: \$4,051.31

From: Rick Kuhl
To: Rick Bogus
Cc: Matt McCaffrey
Subject: Station 2 - Additional Site Paving
Date: Wednesday, January 4, 2023 5:05:57 PM
Attachments: image001.png
image002.png

Good Afternoon Rick,

We learned that when BD was preparing to complete the sewer tie in for the building, that they needed to remove more paving than anticipated to accomplish this work. BD made a judgement call to replace the additional sidewalk and parking stalls as leaving such would present an unsightly (and somewhat deteriorated) patchwork of concrete if this area remained (see image below):

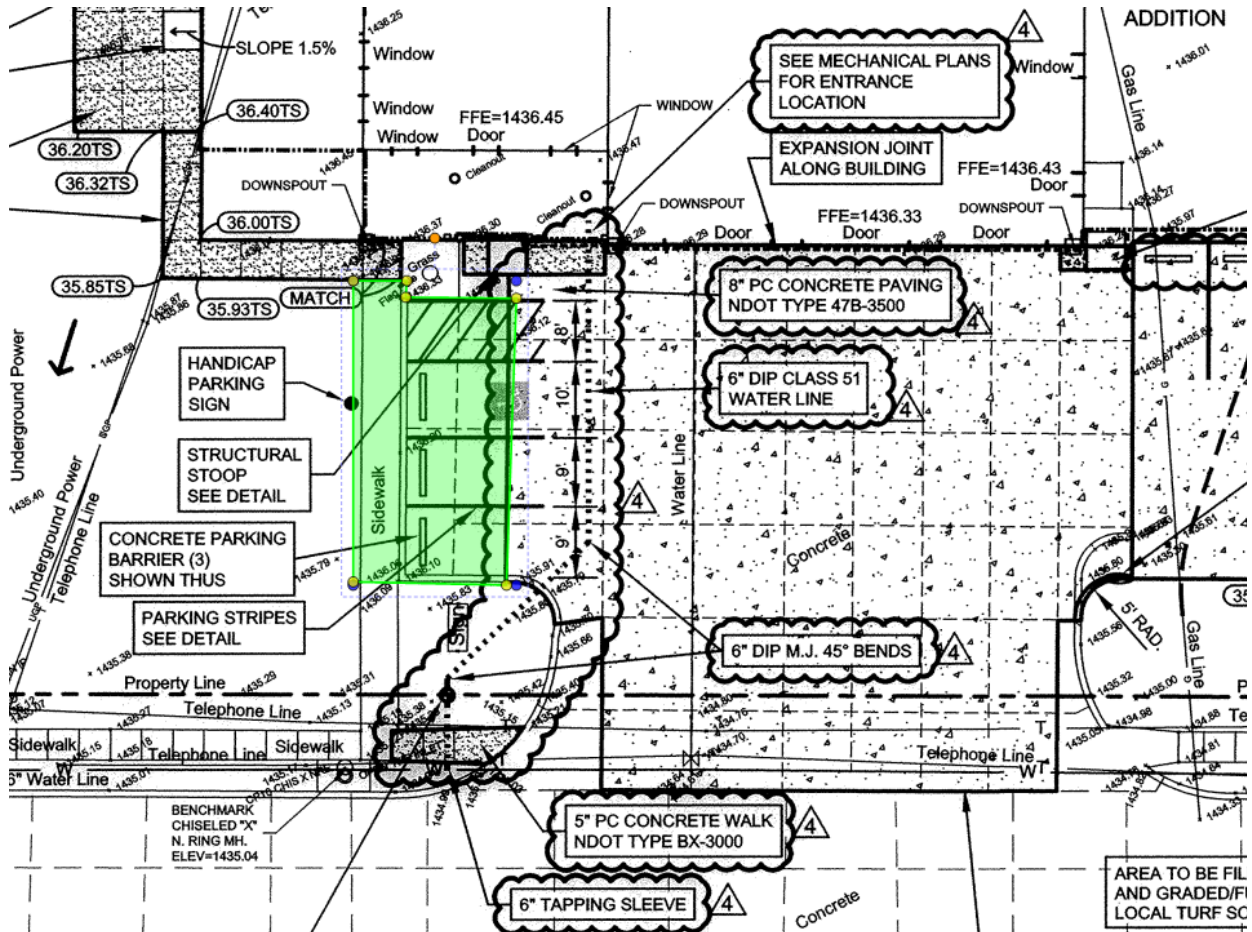

As the timing of this work was such that they could not wait for decision, they replaced this work without approval.

WSKF did have a couple of site survey photos that do display pavement condition in this parking area (see attached) which does indicate cracking and pavement joint deterioration. We also see cracking in the walk at these parking stalls as well.

BD has requested that WSKF present this additional work and cost for the City's consideration. The total cost of the work (subcontractor plus BD OH&P) would be \$4,051.31 and is supported by the subcontractor invoicing below. The unit values seem reasonable for the two types of pavement (walk and drive).



2670 54th Avenue • Columbus, NE 68601
 (402) 564-9680 • Fax (402) 564-6928
 info@plattevalleyprecast.com

INVOICE

DATE: 1/4/2023
 INVOICE #: 8729

BILL TO:

B-D Construction, Inc.
 2154 East 32nd Avenue
 Columbus, NE 68601

PROJECT		P.O.	TERMS
8th St. Fire Station			
QUANTITY	DESCRIPTION	RATE	AMOUNT
375 sq.ft.	Extra's 8" paving	7.00	2,625.00
215 sa.ft.	Sidewalk	5.00	1,075.00

Please advise if this additional work and associated cost would be entertained by the City?

Thanks!

Rick Kuhl RA, MBA
 principal

WSKF Architects



North Kansas City, MO
 816.300.4101
 Kansas City, KS
 913.287.1900



2154 E. 32nd Avenue
 Columbus, NE 68601
 (Phone) 402-564-1225
 (Fax) 402-564-9999

CHANGE ORDER PROPOSAL

NO. PR012

PROJECT: Columbus Fire Station #2
COP NO.: PR012

DATE QUOTED: 03/07/23

PROJECT NO.: 22-024

ARCH. PROJECT NO.: A-1588

TO: Rick Kuhl
 WSKF Architects Inc.
 110 Armour Road
 North Kansas City, MO 64116
 (Phone) 816.300.4101 (Fax) 816.300.4102

DAYS ALLOWED FOR APPROVAL:
EXPIRATION DATE: 03/07/23
REQUESTED EXTENSION OF TIME IN DAYS:

DESCRIPTION:

Added 2" conduit with pull string from Mech Storage 111 to IT 132 for installation of fiber.

SUBCONTRACTORS / VENDORS	SUB / VENDOR WORK DESCRIPTION	AMOUNT:
Kidwell Electric	Electrical	\$1,963.00

B-D Construction, Inc.	5% Mark Up on Subcontractors	\$126.90
B-D Construction, Inc.	Project Manager COP Processing	\$125.00

APPROVAL

TOTAL FROM WORK BREAKDOWN PAGES

NAME: _____	SUB SUBTOTAL:	\$2,214.90
DATE: _____	BOND: 1.2%	\$26.58
SEND COPIES TO		\$0.00
B-D Construction, Inc., Bryan Kearney		\$0.00
WSKF Architects Inc., Rick Kuhl		
City of Columbus, Rick Bogus	SUBTOTAL:	\$2,241.48
B-D CONSTRUCTION, INC.		
BY: <u>Bryan L. Kearney</u>	SUBTOTAL:	\$2,241.48
Bryan Kearney, Project Manager		\$0.00
DATE: 3/7/23	TOTAL COP AMOUNT:	\$2,241.48

Proposed Change Order

Number: 22-0093-10 PCO#8R1

3333 Folkways Cir
Lincoln, NE 68504
(402) 475-9151
FAX (402) 475-9186



To: B-D Construction Attn: Bryan Kearney	Phone: 402-564-1225	Fax: -	Date: 4/6/23
	Job Name/Location: Columbus Fire Station #2 Columbus, NE		

Change is per PR#12 dated 01/27/2023. Provide 2" PVC conduit with pull string from Mech Storage 111 to IT 132 for installation of fiber. See attached breakdown.

Notes

- 1) **MATERIAL PROCUREMENT NOR INSTALLATION WILL BEGIN UNTIL A FULLY EXECUTED CHANGE ORDER HAS BEEN RECEIVED BY KIDWELL.**
- 2) Change does not include any patching, painting, or repair of any surface.
- 3) All work to be completed during Kidwell's normal business hours.
- 4) Change will impact schedule, and require 0 business day(s) time extension.
- 5) No sales tax has been included for material and labor in this proposal.
- 6) All other required taxes will be charged and added to the proposal price on invoicing.
- 7) Does not include fiber install

NOTE: This Proposed Change Order is only good for 10 days due to the rising cost of commodities.
NOTE: This Proposed Change Order becomes part of and in conformance with the existing contract.

CONFIDENTIALITY NOTICE: *This proposal and/or change order and any attachments are strictly confidential and are intended solely for the use of the individual or entity to whom it is addressed. This communication may contain proprietary and financial data of Kidwell Inc. If you are not the intended recipient, be advised that any use, dissemination, forwarding, printing, or copying of this proposal and/or change order and any file attachments is strictly prohibited.*

We Agree hereby to make the change(s) specified above at this price **ADD \$1,963.00**
One Thousand Nine Hundred Sixty-Three Dollars and 00/100 Cents.

Proposed Change Order Prepared By: <u>Brian Mostek</u>	PREVIOUS CONTRACT AMOUNT:
Authorized Kidwell Representative Signature: _____ (CONTRACTOR)	REVISED CONTRACT AMOUNT:

Payment will be made as follows: **MONTHLY**
*Accounts not paid within thirty days are subject to a finance charge of 1% monthly, and an annual rate of 12%.

Accepted- The above prices and specifications of the Change Order are satisfactory and are hereby accepted. All work to be performed under same terms and conditions as specified in original contract unless otherwise stipulated.

Authorized Signature: _____ (OWNER)
Date of Acceptance: _____



DATE:

4/6/2023

ESTIMATED BY:

Brian M.

NAME OF PROJECT:

Columbus Fire Department - Fire Station #2

CHECKED BY:

LG

BID DESC:

PCO#8 - PR#12 - Fiber Conduit - PVC

COST ITEM	Qty.	Material Unit	Material Totals	Labor Unit	Labor MHS
1. Electrical Fixtures			0.00		0.00
2. Material Staging/Handling			0.00		0.00
2" PVC	40	3.45	138.00	0.105	4.20
2" PVC 90 ELBOW	3	5.65	16.95	0.255	0.77
	0	0.00	0.00	0.000	0.00
	0	0.00	0.00	0.000	0.00
	0	0.00	0.00	0.000	0.00
1/4. BEAM CLAMP-MALLABLE	20	1.63	32.60	0.225	4.50
3" HOLE DRILL & PATCH	1	75.00	75.00	3.375	3.38
1/4X1-1/2 FENDER WASHER	20	0.18	3.60	0.002	0.03
1/4/2020 1 1/2 MACHINE SCREW	20	0.08	1.60	0.002	0.03
CHANNEL 12GA 1-5/8"	10	6.25	62.50	0.150	1.50
2" UNISTRUT STRAP	10	1.86	18.60	0.045	0.45
NYLON LINE	50	0.10	5.00	0.002	0.08
3. Miscellaneous (list items)			0.00		0.00
Total Items (1) thru (3) and Labor MH'S			353.85		14.93

4) Labor

a) Total MH'S			14.93	
b) Paid Holiday's Factor			0.00	
c) Productivity Factor			0.00	
d) Height Adj. Factor			0.00	
e) Job Cond. Factor			0.00	
Adjusted MH'S			14.93	
f)	15	MH'S Field Staff	78.60	1179.00
g)	1	MH'S Project Mgr.	86.40	86.40
h)	1	MH'S Superintendant	79.80	79.80
i) Sub-Total Labor			1345.20	
j) Material Tax		0.00 %		0.00
Total Items a-j				1,345.20

5) Subcontracts

a)	
b)	
c)	
d)	
e)	
f)	
g)	

Total Cost Item 5	0.00
--------------------------	------

6) Other Costs

a)	
b)	
c)	
d)	
e)	

Total Cost Item 6	0.00
--------------------------	------

Total Cost Item 1 thru 6			\$1,699.05
Job Overhead Cost			
Add or deduct sheet			
Total Prime Cost			\$1,699.05
Overhead	10	%	\$169.91
Total Cost			\$1,868.96
Profit	5	%	\$93.45
Sub-Total Selling			\$1,962.40
Bond	0	%	\$0.00
Total Selling Price			\$1,963.00



110 Armour Rd
North Kansas City, MO 64116
p. 816.300.4101
wskfarch.com

PROPOSAL REQUEST

Proposal Request No.: **012 (Twelve)**
Date: 01/27/2023
Project: Columbus Fire Station #2

Owner: City of Columbus, NE
To: Bryan Kearney
B-D Construction, Inc.

Project No.: 20023
Contract For: General Construction
Contract Dated: 05/16/2022

Please submit an itemized quotation for changes in the Contract Sum and/or Contract Time, if any, for the proposed modifications to the Contract Documents described herein.

THIS IS NOT A CHANGE ORDER, OR A DIRECTION TO PROCEED WITH THE WORK DESCRIBED HEREIN.

Description:

1. Sheet E3.01 – Special Systems Plan
 - a. Added 2" conduit with pull string from Mech Storage 111 to IT 132 for installation of fiber.

Attachments: E3.01

Signed: Matt McCaffrey
WSKF, Inc.



Missouri Certificate of Authority
#2003011262

Civil Engineer
Gilmore & Associates
State Certificate of Authority
#0000000000
2670 33rd Avenue
Columbus, NE 68601
402-564-2807

Structural Engineer
Bob D. Campbell & Co.
State Certificate of Authority
#0000000000
4338 Bellevue
Kansas City, MO 64111
816-531-4144

MEP Engineer
PKMR Engineers, LLC
State Certificate of Authority
#0000000000
13300 W. 79th Street
Lenexa, KS 66215
913-342-2400

GEN. SPECIAL SYSTEMS NOTES

- REFER TO GENERAL NOTES ON MEP COVER SHEET FOR ADDITIONAL REQUIREMENTS OF WORK.
- REFER TO LOW VOLTAGE RISER DIAGRAMS / DETAILS FOR WORK THAT MAY NOT BE SHOWN ON PLANS.
- EXACT MECHANICAL EQUIPMENT LOCATIONS MAY NOT BE SHOWN FOR CLARITY. COORDINATE EXACT LOCATIONS OF ALL MECHANICAL EQUIPMENT, DUCT DETECTORS, ETC. WITH MECHANICAL DRAWINGS AND CONTRACTOR.
- COORDINATE EXACT LOCATIONS OF SMOKE DETECTORS WITH CEILING FANS, HVAC DIFFUSERS, SPRINKLER HEADS, ETC. PER NFPA REQUIREMENTS.

SPECIAL SYSTEMS KEYED NOTES

- 4"x8"x3/4" FIRE-RATED PLYWOOD BACKBOARD FOR TELECOMMUNICATIONS SERVICE ENTRANCE EQUIPMENT. MOUNT AT 6" AFF.
- COORDINATE EXACT NUMBER/LOCATION OF TAMPER/FLOW SWITCHES, PRESSURE SWITCHES AND POINTS TO BE MONITORED WITH FIRE SPRINKLER CONTRACTOR.
- GROUND BUS. RE. DETAIL AND RISER FOR MORE INFORMATION.
- PROVIDE (1) 4" CONDUITS FOR TELECOMMUNICATIONS SERVICE ENTRANCE CABLING. FURNISH CONDUITS WITH PULLSTRINGS AND BUSHED ENDS.
- CARBON MONOXIDE/NITROGEN DIOXIDE DETECTION SYSTEM. COORDINATED POWER AND WIRING WITH MECHANICAL CONTRACTOR. PROVIDE RECESSED BOX FOR INSTALLATION OF SENSOR AND 3/4" CONDUIT TO ABOVE ACCESSIBLE CEILING FOR WIRING. COORDINATED ROUGH-IN WITH SUPPLIER.
- PROVIDE ROUGH-IN AND WIRING FOR NITROGEN DIOXIDE REMOTE SENSOR. PROVIDE RECESSED BOX FOR INSTALLATION OF SENSOR AND 3/4" CONDUIT TO ABOVE ACCESSIBLE CEILING FOR WIRING. CONDUIT ROUGH-IN WITH SUPPLIER.
- PROVIDE ROUGH-IN AND WIRING FOR CARBON MONOXIDE REMOTE SENSOR. PROVIDE RECESSED BOX FOR INSTALLATION OF SENSOR AND 3/4" CONDUIT TO ABOVE ACCESSIBLE CEILING FOR WIRING. CONDUIT ROUGH-IN WITH SUPPLIER.
- 12" WIDE BASKET CABLE TRAY ABOVE CEILING.
- DROP FOR WIRELESS ACCESS POINT.
- CARD READER IS TO BE MOUNTED ON DOOR MULLION.
- PROVIDE JUNCTION BOX ABOVE CEILING AT DOOR FOR POWER TO DOOR ACCESS CONTROL DEVICES, AND/OR MAG LOCK. RE. ARCHITECTURAL PLANS.
- (2) 4" CONDUITS FOR FUTURE TOWER WIRING. FURNISH CONDUITS WITH PULLSTRINGS AND BUSHED ENDS. RUN CONDUIT TIGHT TO CEILING/STRUCTURE.
- PAGING EQUIPMENT. WALL MOUNTED.
- PROVIDE (2) 2" CONDUITS FROM IT ROOM ACROSS APPARATUS BAY FOR ACCESS CONTROL AND DATA CABLING.
- POWER FOR SPEAKER. FIELD VERIFY EXACT LOCATION.
- COMBINATION SMOKE/CARBON MONOXIDE ALARM.
- ROUTE FIBER OVERHEAD TO IT ROOM (132 IN 2" CONDUIT).
- (1) 2" CONDUIT WITH PULLSTRINGS FOR TELECOMMUNICATIONS CABLING. REFER TO SHEET MEP1.01 FOR CONTINUATION.

SCOPE OF WORK

- ACCESS CONTROL**
ROUGH-IN OF BACKBOXES AND CONDUIT TO ABOVE ACCESSIBLE CEILING
- SURVEILLANCE CAMERA**
PROVIDE RECESSED BOX AND CONDUIT TO ACCESSIBLE CEILING FOR WALL MOUNT EXTERIOR CAMERAS.
- DATA**
PROVIDE RECESSED BOX AND CONDUIT TO ACCESSIBLE CEILING. PULL CAT 6 CABLING AND COIL 2' OF CABLE AT EACH BOX. COVERPLATES, JACKS AND TERMINATIONS DONE BY OTHERS.

NOTE

ALL DATA DROPS SHALL BE BLUE CATEGORY 6 CABLING AND ALL CAMERA DROPS SHALL BE WHITE CATEGORY 6 CABLING.

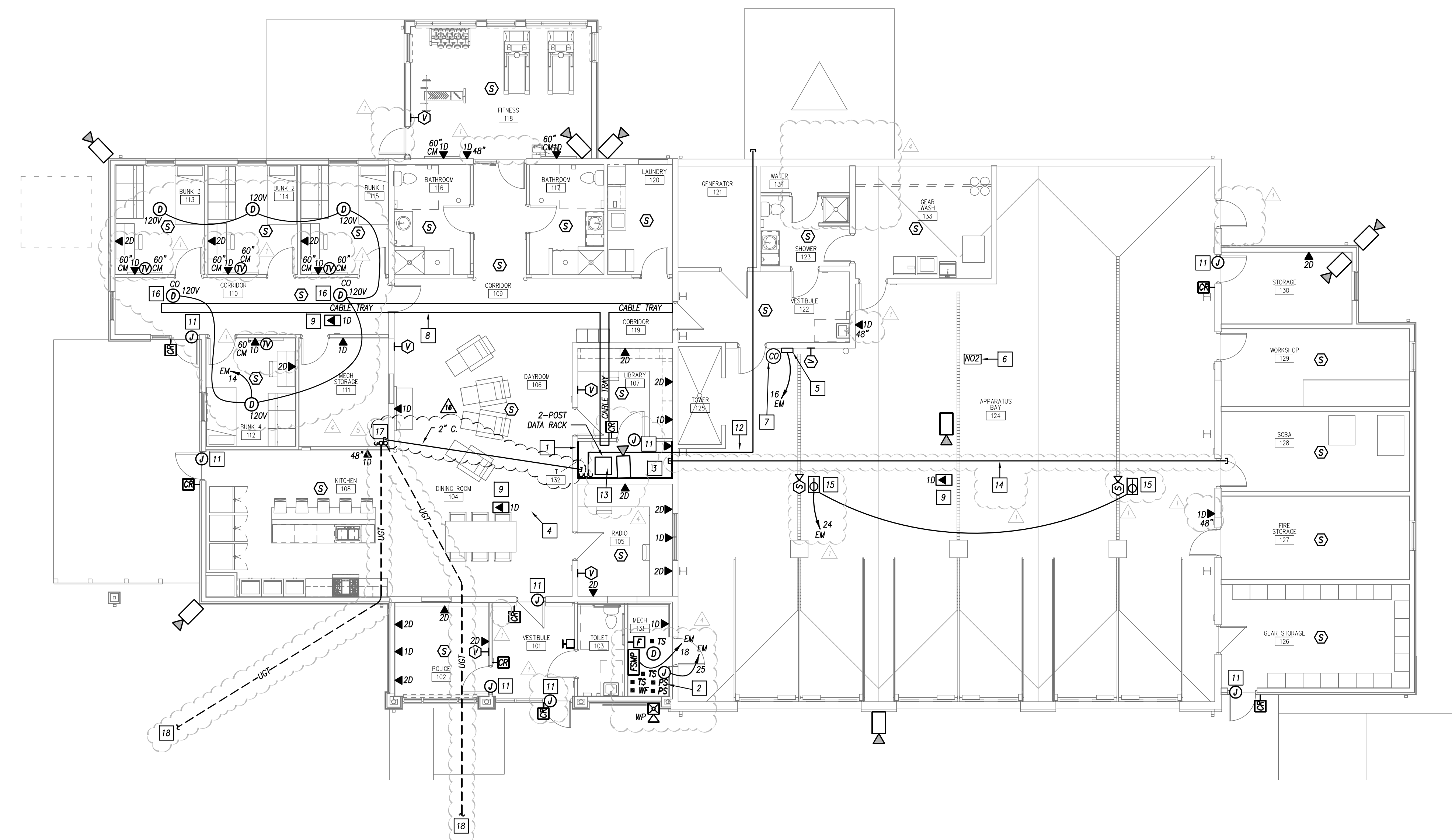

FLOOR PLAN - SPECIAL SYSTEMS
1/8" = 1'-0"

JOB NUMBER 20023

CHARLIE LOUIS FIRE STATION ADDITION

424 8TH STREET
COLUMBUS, NE 68601

CITY OF COLUMBUS, NE
110 Armour Road North Kansas City, Missouri 64116 Tel: 816.300.4101 Fax: 816.300.4102



CONSTRUCTION DOCUMENTS

ISSUE DATE	03/09/2022
No. Description	Date
▲ Addendum #2	03/25/22
▲ Addendum #3	04/06/22
▲ PRO04	07/26/22
▲ PRO05	08/16/22
▲ PR 12	02/17/23

WSKF, Inc. © 2022

SPECIAL SYSTEMS PLAN

E3.01



PEARSON KENT MCKINLEY RAAF ENGINEERS LLC
13300 W 90TH STREET
913.482.2400
LENEXA, KS 66215
WWW.PKMRNG.COM



2154 E. 32nd Avenue
 Columbus, NE 68601
 (Phone) 402-564-1225
 (Fax) 402-564-9999

CHANGE ORDER PROPOSAL

NO. PR013

PROJECT: Columbus Fire Station #2
COP NO.: PR013

DATE QUOTED: 03/07/23

PROJECT NO.: 22-024

ARCH. PROJECT NO.: A-1588

TO: Rick Kuhl
 WSKF Architects Inc.
 110 Armour Road
 North Kansas City, MO 64116
 (Phone) 816.300.4101 (Fax) 816.300.4102

DAYS ALLOWED FOR APPROVAL:
EXPIRATION DATE: 03/07/23
REQUESTED EXTENSION OF TIME IN DAYS:

DESCRIPTION:

- Sheet E2.01 Power Plan
- a. Updated circuits for electric heaters.
 - 2. Sheet E4.01 Electrical Riser Diagram/Schedules
 - a. Moved electric heater EH-2 to existing 30amp 2-pole breaker in Panelboard A.
 - b. Moved electric heater EH-1 to available spare breakers in Panelboard A.
 - c. Added electric heater EH-2 in existing Panelboard C.

SUBCONTRACTORS / VENDORS	SUB / VENDOR WORK DESCRIPTION	AMOUNT:
Kidwell Electric	Electrical	\$1,688.00

B-D Construction, Inc.	5% Mark Up on Sub Contractors	\$198.25
B-D Construction, Inc.	Project Manager COP Processing	\$125.00

APPROVAL TOTAL FROM WORK BREAKDOWN PAGES

NAME: _____	SUB SUBTOTAL:	\$2,011.25
DATE: _____	BOND: 1.2%	\$24.14
SEND COPIES TO		\$0.00
B-D Construction, Inc., Bryan Kearney		\$0.00
WSKF Architects Inc., Rick Kuhl		
City of Columbus, Rick Bogus	SUBTOTAL:	\$2,035.39
B-D CONSTRUCTION, INC.		
BY: <i>Bryan L. Kearney</i>	SUBTOTAL:	\$2,035.39
Bryan Kearney, Project Manager		\$0.00
DATE: 3/7/23	TOTAL COP AMOUNT:	\$2,035.39

Proposed Change Order

Number: 22-0093-10 PCO#7R1

3333 Folkways Cir
Lincoln, NE 68504
(402) 475-9151
FAX (402) 475-9186



To: B-D Construction Attn: Bryan Kearney	Phone: 402-564-1225	Fax: -	Date: 3/20/23
	Job Name/Location: Columbus Fire Station #2 Columbus, NE		

Change is per PR#13 dated 03/07/2023. Update circuit breakers and wiring for EH-1 & EH-2. See attached breakdown.

Notes

- 1) **MATERIAL PROCUREMENT NOR INSTALLATION WILL BEGIN UNTIL A FULLY EXECUTED CHANGE ORDER HAS BEEN RECEIVED BY KIDWELL.**
- 2) Change does not include any patching, painting, or repair of any surface.
- 3) All work to be completed during Kidwell's normal business hours.
- 4) Change will impact schedule, and require 0 business day(s) time extension.
- 5) No sales tax has been included for material and labor in this proposal.
- 6) All other required taxes will be charged and added to the proposal price on invoicing.

NOTE: This Proposed Change Order is only good for 10 days due to the rising cost of commodities.
NOTE: This Proposed Change Order becomes part of and in conformance with the existing contract.

CONFIDENTIALITY NOTICE: *This proposal and/or change order and any attachments are strictly confidential and are intended solely for the use of the individual or entity to whom it is addressed. This communication may contain proprietary and financial data of Kidwell Inc. If you are not the intended recipient, be advised that any use, dissemination, forwarding, printing, or copying of this proposal and/or change order and any file attachments is strictly prohibited.*

We Agree hereby to make the change(s) specified above at this price **ADD \$1,688.00**
One Thousand Six Hundred Eighty-Eight Dollars and 00/100 Cents.

Proposed Change Order Prepared By: <u>Brian Mostek</u>	PREVIOUS CONTRACT AMOUNT:
Authorized Kidwell Representative Signature: _____ (CONTRACTOR)	REVISED CONTRACT AMOUNT:

Payment will be made as follows: **MONTHLY**
*Accounts not paid within thirty days are subject to a finance charge of 1% monthly, and an annual rate of 12%.

Accepted- The above prices and specifications of the Change Order are satisfactory and are hereby accepted. All work to be performed under same terms and conditions as specified in original contract unless otherwise stipulated.	Authorized Signature: _____ (OWNER)
	Date of Acceptance: _____



DATE:

3/20/2023

ESTIMATED BY:

Brian M.

NAME OF PROJECT:

Columbus Fire Department - Fire Station #2

CHECKED BY:

LG

BID DESC:

PCO#7R1 - PR#13 - Electric Heater Changes

COST ITEM	Qty.	Material Unit	Material Totals	Labor Unit	Labor MHS
1. Electrical Fixtures			0.00		0.00
2. Material Staging/Handling			0.00		0.00
		0.00	0.00	0.000	0.00
10 THHN	471	0.35	164.85	0.008	3.53
20/1 CIRCUIT BREAKER	6	33.17	199.02	0.300	1.80
30/2 CIRCUIT BREAKER	2	72.30	144.60	0.450	0.90
12 WIRE TO PULL OUT	471	0.00	0.00	0.006	2.83
		0.00	0.00	0.000	0.00
3. Miscellaneous (list items)			0.00		0.00
Total Items (1) thru (3) and Labor MH'S			508.47		9.06

4) Labor

a) Total MH'S			9.06	
b) Paid Holiday's Factor			0.00	
c) Productivity Factor			0.00	
d) Height Adj. Factor			0.00	
e) Job Cond. Factor			0.00	
Adjusted MH'S			9.06	
f)	10	MH'S Field Staff	78.60	786.00
g)	1	MH'S Project Mgr.	86.40	86.40
h)	1	MH'S Superintendent	79.80	79.80
i) Sub-Total Labor			952.20	
j) Material Tax		0.00 %		0.00
Total Items a-j				952.20

5) Subcontracts

a)	
b)	
c)	
d)	
e)	
f)	
g)	

Total Cost Item 5	0.00
--------------------------	------

6) Other Costs

a)	
b)	
c)	
d)	
e)	

Total Cost Item 6	0.00
--------------------------	------

Total Cost Item 1 thru 6			\$1,460.67
Job Overhead Cost			
Add or deduct sheet			
Total Prime Cost			\$1,460.67
Overhead	10	%	\$146.07
Total Cost			\$1,606.74
Profit	5	%	\$80.34
Sub-Total Selling			\$1,687.07
Bond	0	%	\$0.00
Total Selling Price			\$1,688.00



110 Armour Rd
North Kansas City, MO 64116
p. 816.300.4101
wskfarch.com

PROPOSAL REQUEST

Proposal Request No.: **013 (Thirteen)**
Date: 03/07/2023
Project: Columbus Fire Station #2

Owner: City of Columbus, NE
To: Bryan Kearney
B-D Construction, Inc.

Project No.: 20023
Contract For: General Construction
Contract Dated: 05/16/2022

Please submit an itemized quotation for changes in the Contract Sum and/or Contract Time, if any, for the proposed modifications to the Contract Documents described herein.

THIS IS NOT A CHANGE ORDER, OR A DIRECTION TO PROCEED WITH THE WORK DESCRIBED HEREIN.

Description:

1. Sheet E2.01 – Power Plan
 - a. Updated circuits for electric heaters.
2. Sheet E4.01 – Electrical Riser Diagram/Schedules
 - a. Moved electric heater EH-2 to existing 30amp 2-pole breaker in Panelboard A.
 - b. Moved electric heater EH-1 to available spare breakers in Panelboard A.
 - c. Added electric heater EH-2 in existing Panelboard C.

Attachments: E2.01, E4.01

Signed: Matt McCaffrey
WSKF, Inc.



Missouri Certificate of Authority #2003011262

Civil Engineer
Gillmore & Associates
State Certificate of Authority #0000000000
2670 33rd Avenue
Columbus, NE 68601
402-564-2807

Structural Engineer
Bob D. Campbell & Co.
State Certificate of Authority #0000000000
4338 Bellevue
Kansas City, MO 64111
816-531-4144

MEP Engineer
PKMR Engineers, LLC
State Certificate of Authority #0000000000
13300 W. 98th Street
Lenexa, KS 66215
913-342-2400

JOB NUMBER 20023

CHARLIE LOUIS FIRE STATION ADDITION
424 8TH STREET
COLUMBUS, NE 68601
CITY OF COLUMBUS, NE
110 Armour Road North Kansas City, Missouri 64116 Tel: 816.300.4101 Fax: 816.300.4102

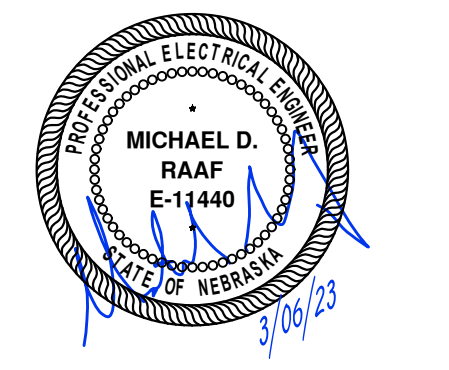

CONSTRUCTION DOCUMENTS	
ISSUE DATE	03/09/2022
No Description	Date
PR#13	03/06/2023

WSKF, Inc. © 2022

POWER PLAN

E2.01



PEARSON KENT MCKINLEY RAAF ENGINEERS LLC
13300 W 98TH STREET
LENEXA, KS 66215
913.482.2400 WWW.PKMRENG.COM

GENERAL POWER NOTES

- REFER TO GENERAL NOTES ON MEP COVER SHEET FOR ADDITIONAL REQUIREMENTS OF WORK.
- COORDINATE EXACT NEMA CONFIGURATIONS OF RECEPTABLES SERVING EQUIPMENT WITH EXACT EQUIPMENT BEING FURNISHED.
- REFER TO THE SPECIFICATIONS FOR ADDITIONAL LOCATIONS/REQUIREMENTS FOR RECEPTABLES, INCLUDING GFCI, WEATHER-RESISTANT, HOSPITAL-GRADE, AND TAMPER-RESISTANT RECEPTABLES.
- EXACT MECHANICAL EQUIPMENT LOCATIONS MAY NOT BE SHOWN FOR CLARITY. COORDINATE EXACT LOCATIONS OF ALL MECHANICAL EQUIPMENT, DUCT DETECTORS, ETC. WITH MECHANICAL DRAWINGS AND CONTRACTOR.
- COORDINATE EXACT LOCATIONS OF SMOKE DETECTORS WITH CEILING FANS, HVAC DIFFUSERS, SPRINKLER HEADS, ETC. PER NFPA REQUIREMENTS.

POWER PLAN KEYED NOTES

- NOT USED.
- ROUTE THROUGH AIR VAC CONTROLLER THEN HOMERUN.
- ROUTE THROUGH CARBON MONOXIDE DETECTOR/CO AND NO2 DUAL DETECTION SYSTEM CONTROLLER, THEN HOMERUN.
- NOT USED.
- PROVIDE CORD REEL MOUNTED AT CEILING FOR TRUCK POWER. WOODHEAD INDUSTRIAL DUTY CORD REEL OR EQUAL. PROVIDE 40 FEET OF CABLE WITH STANDARD NEMA 20AMP RECEPTACLE #10 AWG PLUS #12 GROUND. VERIFY EXACT LOCATION AND RECEPTACLE TYPE WITH OWNER.
- 30AMP, 2-POLE, NON-FUSED, HEAVY-DUTY DISCONNECT SWITCH IN NEMA 1 ENCLOSURE. MAINTAIN SERVICE CLEARANCE ABOUT DISCONNECT PER NEC.
- 30AMP, 2-POLE, NON-FUSED, HEAVY-DUTY DISCONNECT SWITCH IN NEMA 3R ENCLOSURE. MAINTAIN SERVICE CLEARANCE ABOUT DISCONNECT PER NEC.
- 60AMP, 2-POLE, NON-FUSED, HEAVY-DUTY DISCONNECT SWITCH IN NEMA 3R ENCLOSURE. MAINTAIN SERVICE CLEARANCE ABOUT DISCONNECT PER NEC.
- 60AMP, 2-POLE, NON-FUSED, HEAVY-DUTY DISCONNECT SWITCH IN NEMA 1 ENCLOSURE. MAINTAIN SERVICE CLEARANCE ABOUT DISCONNECT PER NEC.
- ROUTE POWER THROUGH HEAT PUMP HP-1.
- CIRCUIT WITH LIGHT FIXTURES THIS AREA.
- ROUTE THROUGH HLS FAN CONTROLLER THEN HOMERUN.
- EAST TRAILER PLUG. 60 AMP PLUS FOR TRAILER. COORDINATE EXACT LOCATION AND NEMA CONFIGURATION WITH OWNER.
- (2) #6 WIRE AND (1) #10 GROUND IN 3/4" CONDUIT.

ALTERNATE NOTES

- BASE BID IS TO REUSE EXISTING DOOR OPENER AND ALL ASSOCIATED EQUIPMENT. IF ALTERNATE IS ACCEPTED, REMOVE AND REPLACE DOOR OPENER ALL ASSOCIATED EQUIPMENT. PROVIDE ALL REQUIRED POWER AND CONTROL WIRING AND ASSOCIATED CONDUIT FOR ACCESSORIES INCLUDING PHOTOELECTRIC EMITTERS AND RECEIVER FOR A COMPLETE SYSTEM. VERIFY DOOR OPERATOR SYSTEM REQUIREMENTS WITH MANUFACTURER PRIOR TO INSTALLATION. PROVIDE WITH 30AMP, 2-POLE, NON-FUSED, HEAVY-DUTY DISCONNECT SWITCH IN NEMA 1 ENCLOSURE MOUNTED MOTOR.
- BASE BID IS TO REUSE EXISTING BANK OF THREE (3) GARAGE DOOR OPENER CONTROLLER. IF ALTERNATE IS ACCEPTED, REMOVE AND REPLACE BANK OF THREE (3) GARAGE DOOR OPENER CONTROLLER OPEN/GLOSE BUTTONS. COORDINATED ROUGH IN AND LOCATIONS WITH DOOR SUPPLIER/INSTALL AND OWNER.

PLUG MOLD

GENERAL:
LEGRAND PLUGMOLD 2000 SERIES. STEEL CONSTRUCTION WITH STAINLESS STEEL FINISH. REFER TO SPECIFICATIONS FOR APPROVED EQUAL MANUFACTURERS.

PLUG MOLD PM2:
LENGTH: 4'-0"

WIRING CONFIGURATION: LEGRAND #GB. SINGLE 20A CIRCUIT.

RECEPTABLES: SIMPLEX RECEPTABLES, MOUNTED 6" O.C. TOTAL OF (8) SIMPLEX RECEPTABLES PER WIREMOLD SECTION.

MARK	SYMBOL	FLOOR BOX DETAIL	SUB-PLATE / DEVICE DETAIL
FB-1	[FB]	<p>RECESSED COMBINATION POWER/DATA FLOOR BOX</p> <p>RECTANGULAR CARPET/TILE COVER ASSEMBLY - ADA COMPLIANT WITH TWO CABLE EGRESS DOORS AND ACCESS 180° OPENING. POWDER-COATED BLACK FINISH.</p> <p>RECESSED CAST IRON FLOOR BOX. HUBBELL #CFB4G30.</p> <p>3/4" TO 1-1/2" KNOCKOUTS FOR CONDUIT ACCESS.</p>	<p>SUB-PLATES (TWO PER END)</p> <p>SECTION VIEW 'A'</p> <p>SECTION VIEW 'B'</p>
		<p>FLOOR BOX GENERAL COMMENTS:</p> <ol style="list-style-type: none"> APPROVED EQUALS TO BOX INFORMATION SPECIFIED ABOVE MAY BE FURNISHED - REFER TO SPECIFICATIONS. FURNISH FLOOR BOXES WITH ALL REQUIRED MOUNTING ACCESSORIES NOT LISTED. CONTRACTOR SHALL VERIFY FLOOR SLAB THICKNESS MEETS MINIMUM REQUIREMENTS FOR BOXES USED. FLOOR BOXES NOTED ABOVE AS BEING FOR MULTI-SERVICE USE SHALL BE FURNISHED WITH INTEGRAL DIVIDERS TO SEPARATE 120V AND LOW VOLTAGE WIRING. COORDINATE COVER COLOR WITH ARCHITECT/OWNER PRIOR TO ORDERING. 	<p>SUB-PLATE GENERAL COMMENTS:</p> <ol style="list-style-type: none"> COORDINATE SUB-PLATE AND DEVICE COLORS WITH ARCHITECT/OWNER PRIOR TO ORDERING. LOW-VOLTAGE DEVICES TO BE PROVIDED BY OTHERS UNLESS OTHERWISE NOTED. ALL LINE VOLTAGE WIRING TO DEVICES BY CONTRACTOR. REFER TO PLANS AND SPECIFICATIONS FOR ADDITIONAL INFORMATION ON RECEPTABLE TYPES/REQUIREMENTS.

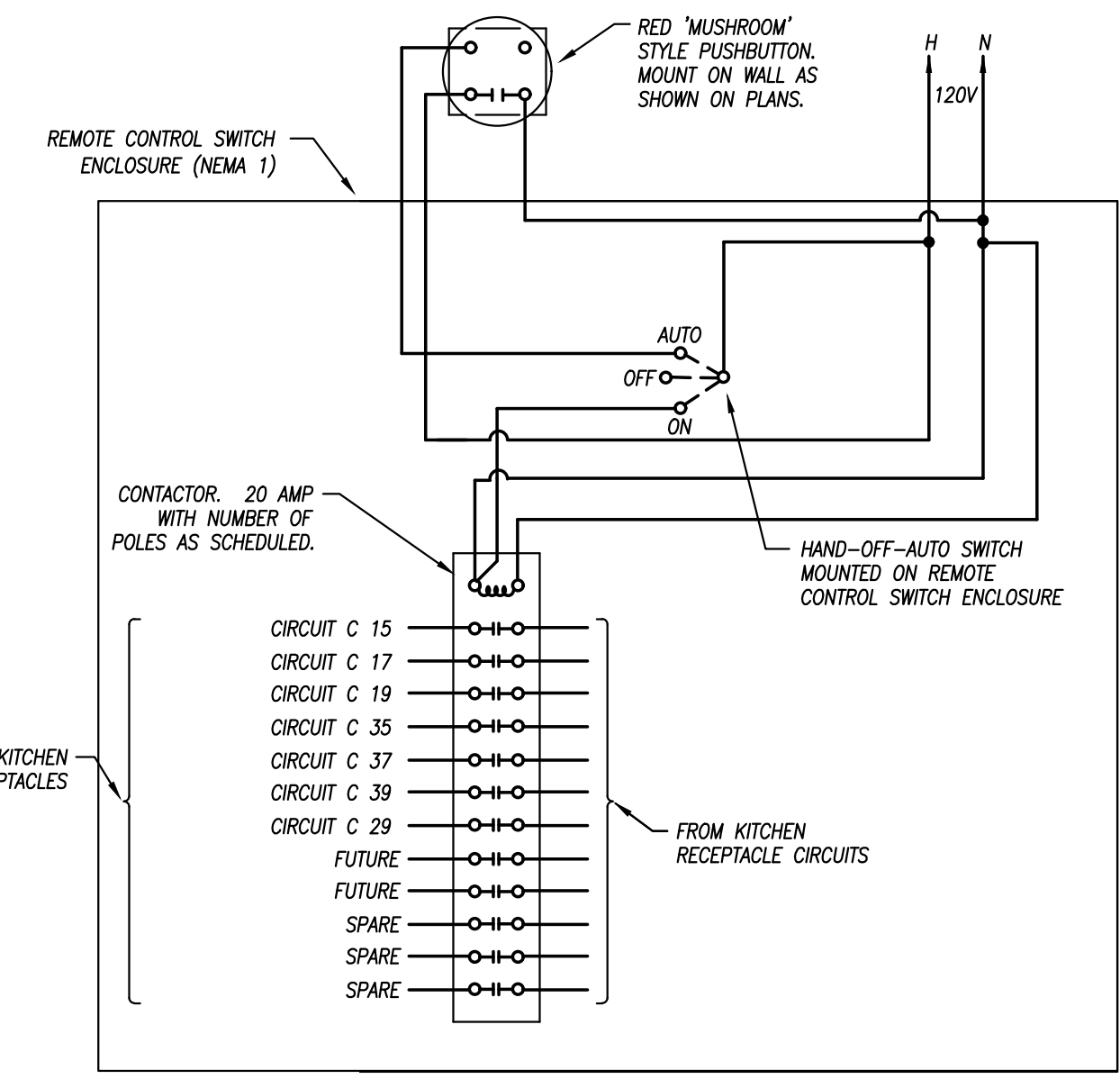

KITCHEN EQUIPMENT 'OFF' CONTROL (RCS-2)
NOT TO SCALE

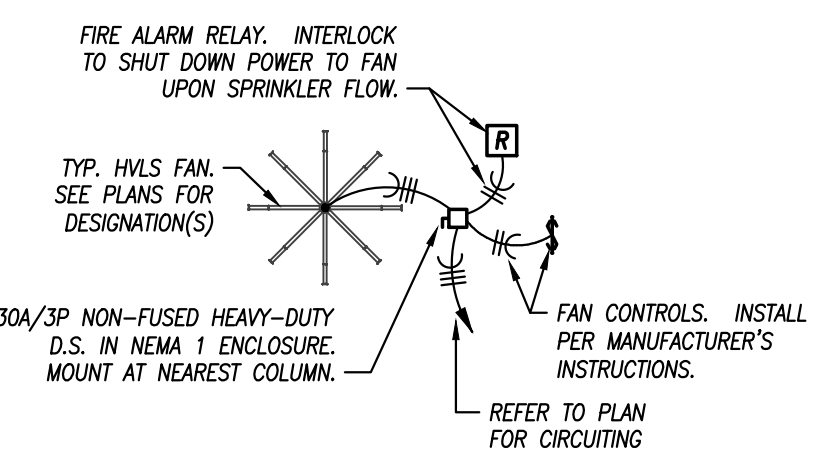

TYPICAL HVLS FAN WIRING
NOT TO SCALE

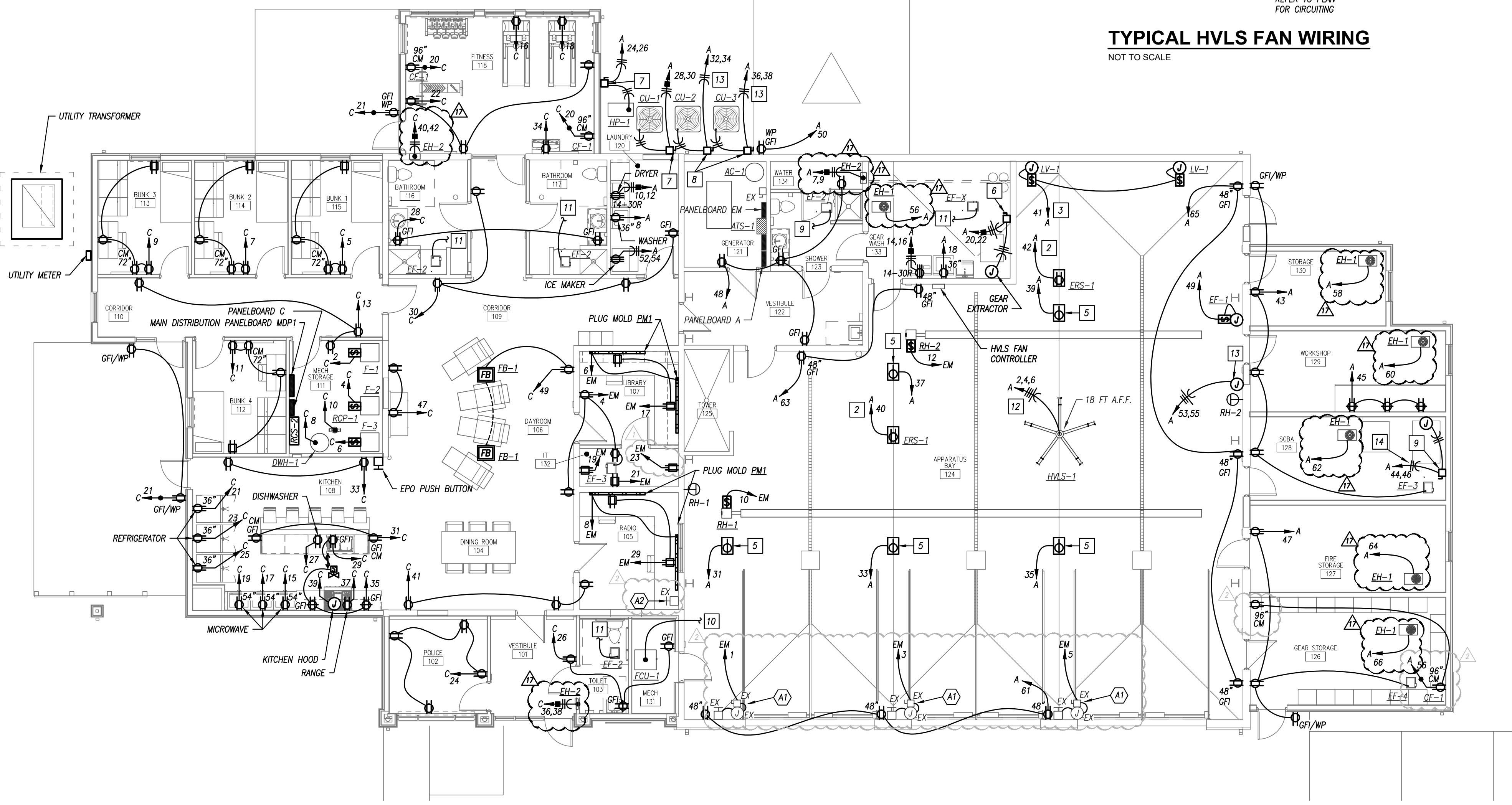

FLOOR PLAN - POWER
1/8" = 1'-0"

H
G
F
E
D
C
B
A



Missouri Certificate of Authority #2003011262

Civil Engineer Gilmore & Associates State Certificate of Authority #0000000000 2670 33rd Avenue Columbus, MO 68601 402-564-2807

Structural Engineer Bob D. Campbell & Co. State Certificate of Authority #0000000000 4338 Bellevue Kansas City, MO 64111 816-531-4144

MEP Engineer PKMR Engineers, LLC State Certificate of Authority #0000000000 13300 W. 98th Street Lenexa, KS 66215 913-342-2400

JOB NUMBER 20023

CHARLIE LOUIS FIRE STATION ADDITION

424 8TH STREET COLUMBUS, NE 68601

CITY OF COLUMBUS, NE 110 Armour Road North Kansas City, Missouri 64116 Tel: 816.300.4101 Fax: 816.300.4102

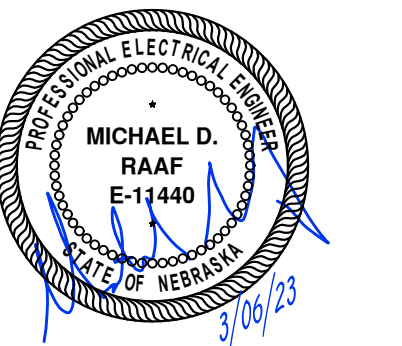

CONSTRUCTION DOCUMENTS

ISSUE DATE 03/09/2022 No Description Date PR#13 03/06/2023

WSKF, Inc. © 2022

ELECTRICAL RISER DIAGRAM SCHEDULES

E4.01

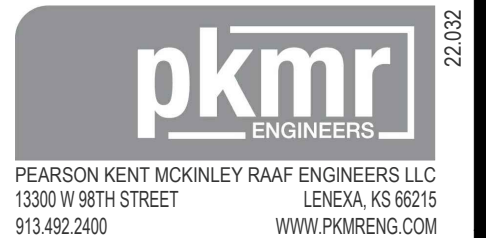

PEARSON KENT MCKINLEY RAAF ENGINEERS LLC 13300 W 98TH STREET LENEXA, KS 66215 913.482.2400 WWW.PKMRNG.COM

RISERKEYED NOTES

- (1) (2) 4" CONDUIT WITH PULL STRINGS AND WARNING TAPE. REFER TO CIVIL PLANS FOR CONTINUATION. COORDINATE ALL WORK WITH UTILITY.
(3) CONCRETE TRANSFORMER PAN PER UTILITY STANDARDS. REFER TO SITE PLAN.
(4) MOUNT ON SIDE OF BUILDING PER UTILITY STANDARDS. REFER TO SITE AND POWER PLANS.
(5) GROUND BUS LOCATED IN TECH ROOM. REFER TO DETAIL ON SHEET E4.02. BOND TO GROUNDING ELECTRODE SYSTEM.
(6) EXISTING DIESEL GENERATOR TO REMAIN.
(7) REMOVE EXISTING TRANSFORMER AND ALL ASSOCIATED WIRING AND CONDUIT. COORDINATE ALL WORK WITH UTILITY COMPANY.
(8) REMOVE EXISTING METER AND ALL ASSOCIATED WIRING AND CONDUIT. COORDINATE ALL WORK WITH UTILITY COMPANY.

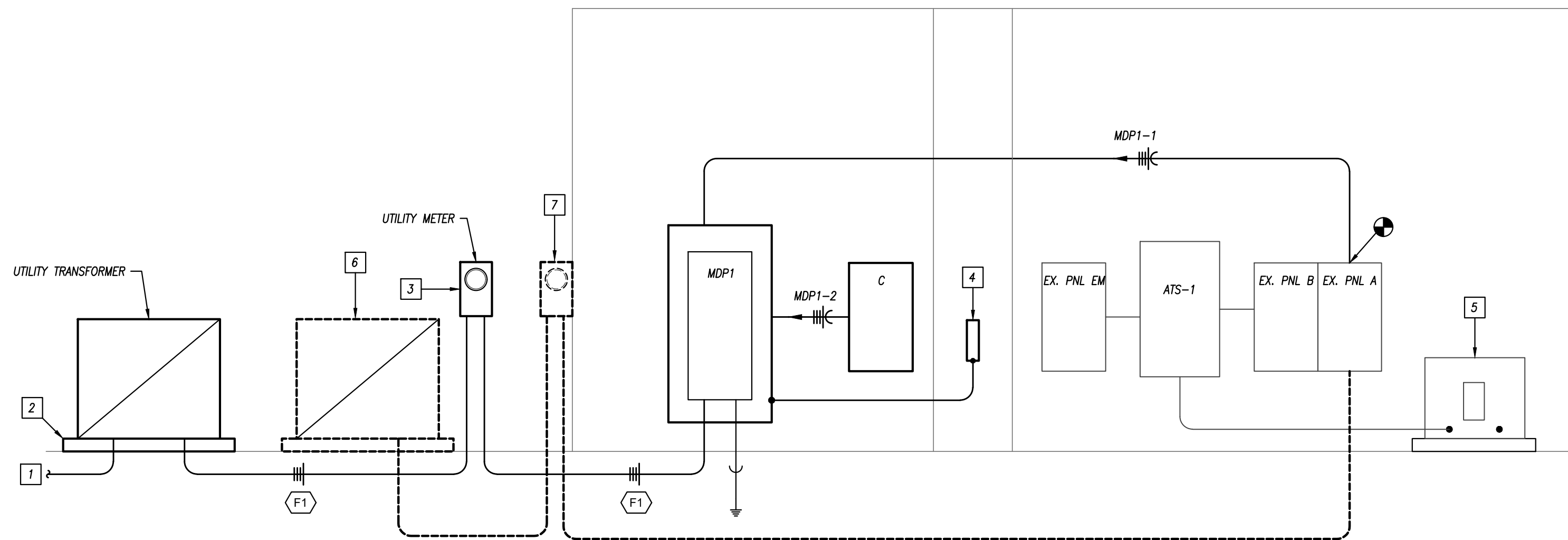

ELECTRICAL RISER DIAGRAM NOT TO SCALE

EXISTING TWO-SECTION PANELBOARD SCHEDULE

Table with columns for Panel Designation (A), Description, Phase (A, B, C), Trip, Pole, and Description. Includes items like LTS: EXTERIOR, RECEPT: SHOWER WATER VEST, ELECTRIC HEATER EH-2, etc.

SECOND SECTION: B (2)

Table with columns for Description, Phase (A, B, C), Trip, Pole, and Description. Includes items like RECEPT: STORAGE, SHOP, SCBA, RECEPT: WORKSHOP, etc.

PANELBOARD SIZING LOAD

Table with columns for Load Description, Connected, Demand, Code Min. (VA), and Sizing Load (AMPS).

CONNECTED PHASE LOADS

Table with columns for Phase (A, B, C), VA, and AMPS.

REMARKS: 1. CUTLER HAMMER POW-R-LINE 1A OR EQUAL.

SINGLE-SECTION PANELBOARD SCHEDULE

Table with columns for Panel Designation (C), Description, Phase (A, B, C), Trip, Pole, and Description. Includes items like SPARE, RECEPT: BUNK 1, RECEPT: BUNK 2, etc.

PANELBOARD SIZING LOAD

Table with columns for Load Description, Connected, Demand, Code Min. (VA), and Sizing Load (AMPS).

CONNECTED PHASE LOADS

Table with columns for Phase (A, B, C), VA, and AMPS.

REMARKS: 1. CUTLER HAMMER POW-R-LINE 2A OR EQUAL.

EXISTING SINGLE-SECTION PANELBOARD SCHEDULE

Table with columns for Panel Designation (EM), Description, Phase (A, B, C), Trip, Pole, and Description. Includes items like WEST OVERHEAD DOOR, MIDDLE OVERHEAD DOOR, etc.

PANELBOARD SIZING LOAD

Table with columns for Load Description, Connected, Demand, Code Min. (VA), and Sizing Load (AMPS).

CONNECTED PHASE LOADS

Table with columns for Phase (A, B, C), VA, and AMPS.

REMARKS: 1. CUTLER HAMMER POW-R-LINE 1A OR EQUAL.

ELECTRICAL SERVICE GROUNDING DETAIL

NOT TO SCALE

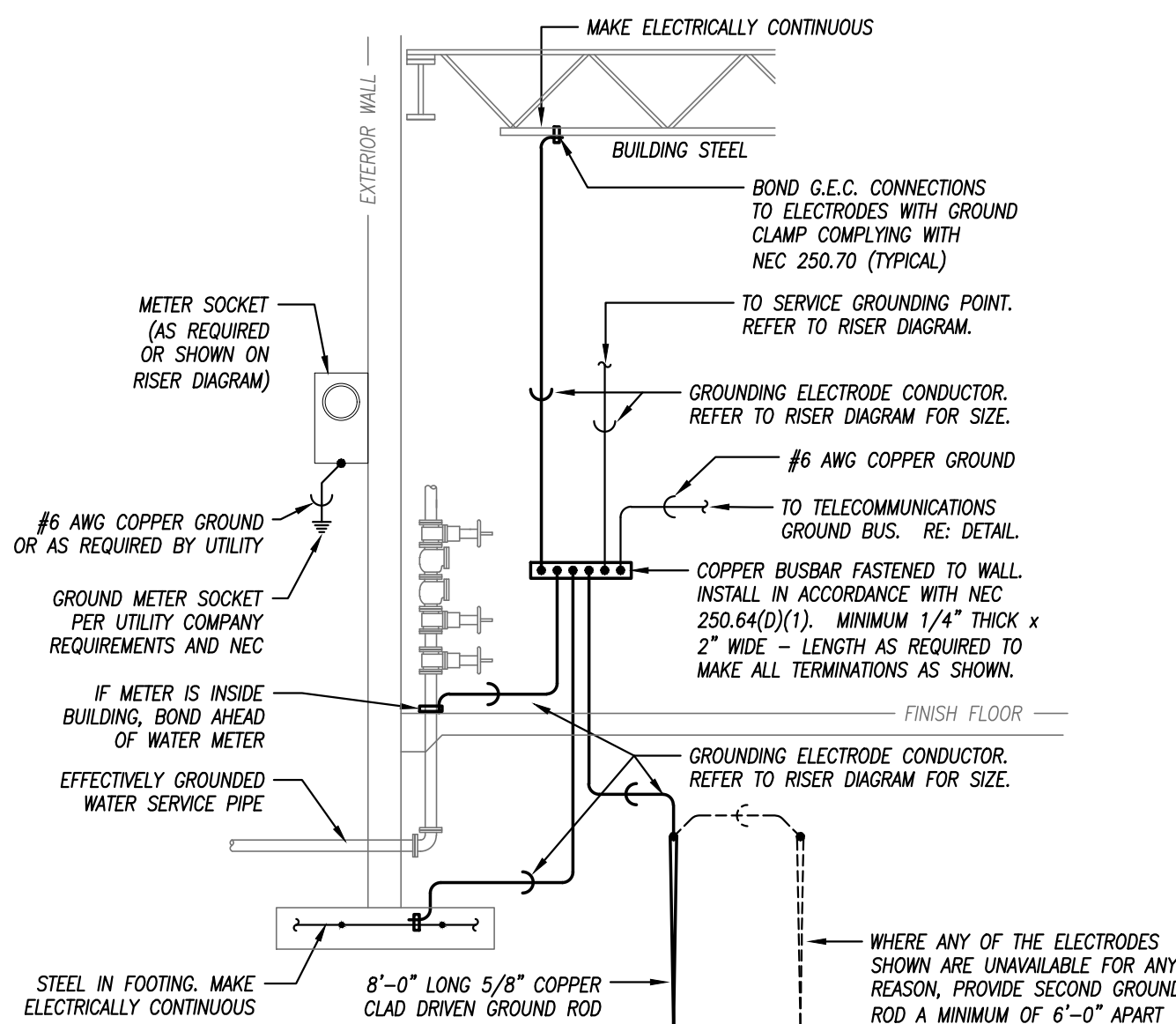

DISTRIBUTION PANELBOARD SCHEDULE

Table with columns for Circuit No., Circuit Designation, KVA, Circuit Breaker (Pole, Frame, Trip), Sets, # of Wires, Feeder (Size, Ground, Conduit), and Description.

PANELBOARD SIZING LOAD

Table with columns for Load Description, Connected Load, Demand Factor, Code Min. (VA), and Sizing Load (AMPS).

REMARKS: 1. CUTLER HAMMER POW-R-LINE 4B PANELBOARD OR EQUAL. 2. SINGLE SECTION, 44" WIDE PANELBOARD. 3. FURNISH PANELBOARD WITH EXTERNAL SPD.

EQUIPMENT FAULT CURRENT RATING SCHEDULE

Table with columns for Equipment, SCA**, SCCR, and Notes.

NOTES: 1. RATING BASED ON AN ASSUMED FAULT AT UTILITY CO. TRANSFORMER OF 38,914A. ** CALCULATIONS PERFORMED USING BUSSMANN POINT-TO-POINT METHOD.

EQUIPMENT FEEDER SCHEDULE

Table with columns for Feeder No., Equipment, Load (AMPS), Sets, # of Wires, Feeder (Size, Material, Conduit Size), and Description.



2154 E. 32nd Avenue
 Columbus, NE 68601
 (Phone) 402-564-1225
 (Fax) 402-564-9999

CHANGE ORDER PROPOSAL

NO. 016

PROJECT: Columbus Fire Station #2
COP NO.: 016

DATE QUOTED: 04/05/23

PROJECT NO.: 22-024

ARCH. PROJECT NO.: A-1588

TO: Rick Kuhl
 WSKF Architects Inc.
 110 Armour Road
 North Kansas City, MO 64116
 (Phone) 816.300.4101 (Fax) 816.300.4102

DAYS ALLOWED FOR APPROVAL:
EXPIRATION DATE: 04/05/23
REQUESTED EXTENSION OF TIME IN DAYS:

DESCRIPTION:

Added additional steel front porch column and adjust gate anchorage to building. Galvaniizng of gate material and additional hardware.

SUBCONTRACTORS / VENDORS	SUB / VENDOR WORK DESCRIPTION	AMOUNT:
Husker Steel	Structural Steel Supply / Galvanizing	\$846.00
No Swett Fencing	Fencing Install	\$1,823.00

B-D Construction, Inc.	5% Mark Up on Sub Contractors	\$133.45
B-D Construction, Inc.	Project Manager COP Processing	\$125.00

APPROVAL

TOTAL FROM WORK BREAKDOWN PAGES

NAME: _____	SUB SUBTOTAL:	\$2,927.45
DATE: _____	BOND: 1.2%	\$35.13
SEND COPIES TO		\$0.00
B-D Construction, Inc., Bryan Kearney		\$0.00
WSKF Architects Inc., Rick Kuhl		
City of Columbus, Rick Bogus	SUBTOTAL:	\$2,962.58
B-D CONSTRUCTION, INC.		
BY: _____	SUBTOTAL:	\$2,962.58
Bryan Kearney, Project Manager		\$0.00
DATE: 4/5/23	TOTAL COP AMOUNT:	\$2,962.58



2154 E. 32nd Avenue
 Columbus, NE 68601
 (Phone) 402-564-1225
 (Fax) 402-564-9999

CHANGE ORDER PROPOSAL

NO.

PR015

PROJECT: Columbus Fire Station #2
COP NO.: PR015

DATE QUOTED: 03/16/23

PROJECT NO.: 22-024

ARCH. PROJECT NO.: A-1588

TO: Rick Kuhl
 WSKF Architects Inc.
 110 Armour Road
 North Kansas City, MO 64116
 (Phone) 816.300.4101 (Fax) 816.300.4102

DAYS ALLOWED FOR APPROVAL:

EXPIRATION DATE: 03/16/23

REQUESTED EXTENSION OF TIME IN DAYS:

DESCRIPTION:

Provide GFCI protected receptacles in lieu of non-protected receptacle at the washing machines to protect panelboard A circuits 8 and 18 as instructed by the code official.

Provide GFCI protected breaker 20amp 2-pole breaker in lieu of non-protected breaker for the ice machine to protect panelboard A circuits 52, 54 as instructed by the code official.

SUBCONTRACTORS / VENDORS	SUB / VENDOR WORK DESCRIPTION	AMOUNT:
Kidwell Electric	Electrical	\$1,503.00

B-D Construction, Inc.	5% Mark Up on Subcontracts	\$75.15
B-D Construction, Inc.	Project Manager COP Processing	\$125.00

APPROVAL

TOTAL FROM WORK BREAKDOWN PAGES

SUB SUBTOTAL: \$1,703.15

NAME: _____

BOND: 1.2% \$20.44

DATE: _____

\$0.00

SEND COPIES TO

\$0.00

B-D Construction, Inc., Bryan Kearney
 WSKF Architects Inc., Rick Kuhl
 City of Columbus, Rick Bogus

\$0.00

SUBTOTAL: \$1,723.59

B-D CONSTRUCTION, INC.

BY: *Bryan L. Kearney*
 Bryan Kearney, Project Manager

SUBTOTAL: \$1,723.59

\$0.00

DATE: 3/16/23

TOTAL COP AMOUNT: \$1,723.59

Proposed Change Order

Number: 22-0093-10 PCO#6

3333 Folkways Cir
Lincoln, NE 68504
(402) 475-9151
FAX (402) 475-9186



To: B-D Construction Attn: Bryan Kearney	Phone: 402-564-1225	Fax: -	Date: 1/19/23
	Job Name/Location: Columbus Fire Station #2 Columbus, NE		

Change is to provide GFCI circuit breakers for the washers (Panel A- 8 & 18) & ice maker (Panel B- 52,54) This is being required by the Electrical Inspector. See attached breakdown.

Notes

- 1) **MATERIAL PROCUREMENT NOR INSTALLATION WILL BEGIN UNTIL A FULLY EXECUTED CHANGE ORDER HAS BEEN RECEIVED BY KIDWELL.**
- 2) Change does not include any patching, painting, or repair of any surface.
- 3) All work to be completed during Kidwell's normal business hours.
- 4) Change will impact schedule, and require 0 business day(s) time extension.
- 5) No sales tax has been included for material and labor in this proposal.
- 6) All other required taxes will be charged and added to the proposal price on invoicing.

NOTE: This Proposed Change Order is only good for 10 days due to the rising cost of commodities.
NOTE: This Proposed Change Order becomes part of and in conformance with the existing contract.

CONFIDENTIALITY NOTICE: *This proposal and/or change order and any attachments are strictly confidential and are intended solely for the use of the individual or entity to whom it is addressed. This communication may contain proprietary and financial data of Kidwell Inc. If you are not the intended recipient, be advised that any use, dissemination, forwarding, printing, or copying of this proposal and/or change order and any file attachments is strictly prohibited.*

We Agree hereby to make the change(s) specified above at this price **ADD \$1,503.00**
One Thousand Five Hundred Three Dollars and 00/100 Cents.

Proposed Change Order Prepared By: <u>Brian Mostek</u>	PREVIOUS CONTRACT AMOUNT:
	REVISED CONTRACT AMOUNT:
Authorized Kidwell Representative Signature: _____ (CONTRACTOR)	

Payment will be made as follows: **MONTHLY**
*Accounts not paid within thirty days are subject to a finance charge of 1% monthly, and an annual rate of 12%.

Accepted- The above prices and specifications of the Change Order are satisfactory and are hereby accepted. All work to be performed under same terms and conditions as specified in original contract unless otherwise stipulated.

Authorized Signature: _____ (OWNER)
Date of Acceptance: _____

4) Labor

a) Total MH'S			1.50	
b) Paid Holiday's Factor		%	0.00	
c) Productivity Factor		%	0.00	
d) Height Adj. Factor		%	0.00	
e) Job Cond. Factor		%	0.00	
Adjusted MH'S			1.50	
f)	2	MH'S Field Staff	63.55	127.10
g)	1	MH'S Project Mgr.	85.05	85.05
h)	1	MH'S Superintendant	73.75	73.75
i) Sub-Total Labor			285.90	
j) Material Tax		0.00 %		0.00
Total Items a-j				285.90

5) Subcontracts

a)	
b)	
c)	
d)	
e)	
f)	
g)	

Total Cost Item 5	0.00
--------------------------	------

6) Other Costs

a)	
b)	
c)	
d)	
e)	

Total Cost Item 6	0.00
--------------------------	------

Total Cost Item 1 thru 6		\$1,300.81
Job Overhead Cost		
Add or deduct sheet		
Total Prime Cost		\$1,300.81
Overhead	10 %	\$130.08
Total Cost		\$1,430.89
Profit	5 %	\$71.54
Sub-Total Selling		\$1,502.44
Bond	0 %	\$0.00
Total Selling Price		\$1,503.00



110 Armour Rd
North Kansas City, MO 64116
p. 816.300.4101
wskfarch.com

PROPOSAL REQUEST

Proposal Request No.: **015 (Fifteen)**
Date: 03/14/2023
Project: Columbus Fire Station #2

Owner: City of Columbus, NE
To: Bryan Kearney
B-D Construction, Inc.

Project No.: 20023
Contract For: General Construction
Contract Dated: 05/16/2022

Please submit an itemized quotation for changes in the Contract Sum and/or Contract Time, if any, for the proposed modifications to the Contract Documents described herein.

THIS IS NOT A CHANGE ORDER, OR A DIRECTION TO PROCEED WITH THE WORK DESCRIBED HEREIN.

Description:

1. Sheet E2.01 – Power Plan
 - a. Provide GFCI protected receptacles in lieu of non-protected receptacle at the washing machines to protect panelboard A circuits 8 and 18 as instructed by the code official.
2. Sheet E4.01 – Electrical Riser Diagram Schedules
 - a. Provide GFCI protected breaker 20amp 2-pole breaker in lieu of non-protected breaker for the ice machine to protect panelboard A circuits 52, 54 as instructed by the code official.

Attachments: None

Signed: Matt McCaffrey
WSKF, Inc.



2154 E. 32nd Avenue
 Columbus, NE 68601
 (Phone) 402-564-1225
 (Fax) 402-564-9999

CHANGE ORDER PROPOSAL

NO. 017

PROJECT: Columbus Fire Station #2
COP NO.: 017

DATE QUOTED: 04/05/23

PROJECT NO.: 22-024

ARCH. PROJECT NO.: A-1588

TO: Rick Kuhl
 WSKF Architects Inc.
 110 Armour Road
 North Kansas City, MO 64116
 (Phone) 816.300.4101 (Fax) 816.300.4102

DAYS ALLOWED FOR APPROVAL:
EXPIRATION DATE: 04/05/23
REQUESTED EXTENSION OF TIME IN DAYS:

DESCRIPTION:

Painting of CMU on Hose Tower

SUBCONTRACTORS / VENDORS	SUB / VENDOR WORK DESCRIPTION	AMOUNT:
Kucera Painting	Painting	\$1,125.00

B-D Construction, Inc.	5% Mark Up on Subcontractors	\$64.00
B-D Construction, Inc.	Project Manager COP Processing	\$125.00

APPROVAL

TOTAL FROM WORK BREAKDOWN PAGES

NAME: _____	SUB SUBTOTAL:	\$1,314.00
DATE: _____	BOND: 1.2%	\$15.77
SEND COPIES TO		\$0.00
B-D Construction, Inc., Bryan Kearney		\$0.00
WSKF Architects Inc., Rick Kuhl		
City of Columbus, Rick Bogus	SUBTOTAL:	\$1,329.77
B-D CONSTRUCTION, INC.		
BY: _____	SUBTOTAL:	\$1,329.77
Bryan Kearney, Project Manager		\$0.00
DATE: 4/5/23	TOTAL COP AMOUNT:	\$1,329.77



2154 E. 32nd Avenue
 Columbus, NE 68601
 (Phone) 402-564-1225
 (Fax) 402-564-9999

CHANGE ORDER PROPOSAL

NO. 018

PROJECT: Columbus Fire Station #2
COP NO.: 018

DATE QUOTED: 04/12/23

PROJECT NO.: 22-024

ARCH. PROJECT NO.: A-1588

TO: Rick Kuhl
 WSKF Architects Inc.
 110 Armour Road
 North Kansas City, MO 64116
 (Phone) 816.300.4101 (Fax) 816.300.4102

DAYS ALLOWED FOR APPROVAL:
EXPIRATION DATE: 04/12/23
REQUESTED EXTENSION OF TIME IN DAYS:

DESCRIPTION:

Per RFI#23, the existing Type U Undercabinet Lights that were specified will not work due to them being longer than the allowable space provided.

New Lighting was specified for replacement of these fixtures.

SUBCONTRACTORS / VENDORS	SUB / VENDOR WORK DESCRIPTION	AMOUNT:
Kidwell Electric	Electrical	\$402.00

B-D Construction, Inc.	5% Mark Up on Sub Contractors	\$20.10
B-D Construction, Inc.	Project Manager COP Processing	\$125.00

APPROVAL

TOTAL FROM WORK BREAKDOWN PAGES

NAME: _____	BOND: 1.2%	SUB SUBTOTAL:	\$547.10
DATE: _____			\$6.57
SEND COPIES TO			\$0.00
B-D Construction, Inc., Bryan Kearney			\$0.00
WSKF Architects Inc., Rick Kuhl			
City of Columbus, Rick Bogus		SUBTOTAL:	\$553.67
B-D CONSTRUCTION, INC.			
BY: <i>Bryan L. Kearney</i>		SUBTOTAL:	\$553.67
Bryan Kearney, Project Manager			\$0.00
DATE: 4/12/23		TOTAL COP AMOUNT:	\$553.67



B-D Construction, Inc.
 2154 East 32nd Avenue
 Columbus, Nebraska 68601
 P: (402) 564-1225
 F: (402) 564-9999

**Project: 22-024 Columbus Fire Station #2
 Renovation & Expansion- Charlie Louis**
 424 8th Street
 Columbus, Nebraska 68601
 P: 402-564-1225
 F: 402-564-9999

RFI #23: Type U Fixture Length

Status	Open		
To	Matt McCaffrey (Williams Spurgeon Kuhl & Freshnock Architects, Inc.)	From	Bryan Kearney (B-D Construction, Inc.) 4032 60th STREET COLUMBUS, Nebraska 68601
Date Initiated	Mar 13, 2023	Due Date	Mar 16, 2023
Location		Project Stage	Course of Construction
Cost Impact		Schedule Impact	Yes (Unknown)
Spec Section	260000 - Electrical	Cost Code	
Drawing Number	E101	Reference	
Linked Drawings			
Received From	Levi Griffis (Kidwell)		
Copies To	Levi Griffis (Kidwell), Kevin Rubeck (B-D Construction, Inc.)		

Activity

Question

Question from Bryan Kearney B-D Construction, Inc. on Monday, Mar 13, 2023 at 01:53 PM CDT

The type U fixtures shown next to the range in Kitchen 108 are called out to be 48" long. The cabinets are not wide enough for these fixtures to work. We would need to order 24" long fixtures for them to fit under the current cabinets. Please advise.

Awaiting an Official Response

I am in agreement with the HUC523 on the smaller cabinet. Please verify with the light fixture manufacturer to see if the HUC535 will fit within the as-built space. If not, then please proceed with the HUC523. Also, apologies for forgetting about the cabinet size changes.

WSKF Architects
 Matt McCaffrey.



FIXTURE	NOMINAL LENGTH (FT)	ACTUAL LENGTH (IN)	LENGTH WITH LINKING CONNECTORS (IN)	MOUNTING LENGTH (IN)	SIDE EDGE TO KEYHOLE CENTER (IN)	BACK EDGE TO KEYHOLE CENTER (IN)	FIXTURE WEIGHT
HUC512	1	12.07	12.63	9	1.54	2.61	2.1 LBS
HUC519	1.5	19	19.56	12.92	3.04	2.62	3.2 LBS
HUC523	2	23.15	23.71	17	3.08	2.63	3.7 LBS
HUC535	3	34.9	35.46	28	3.45	2.63	5.7 LBS
HUC546	4	46.19	46.75	40	3.09	2.7	7.3 LBS

Bryan Kearney

From: Matt McCaffrey <MMcCaffrey@wskfarch.com>
Sent: Monday, April 10, 2023 10:37 AM
To: Bryan Kearney
Subject: FW: Columbus Fire Station #2

Bryan_

Please see the link below for a replacement undercabinet fixture. Please have your electrician review and advise. Thank you.

Matt McCaffrey
WSKF, Inc.
P.816.300.4101 F.816.300.4102 www.wskfarch.com

From: Antonio McBee <antonio.mcbee@pkmreng.com>
Sent: Friday, April 7, 2023 4:46 PM
To: Matt McCaffrey <MMcCaffrey@wskfarch.com>
Cc: Mike Raaf <mike.raaf@pkmreng.com>; Kevin Zimmerman <kevin.zimmerman@pkmreng.com>; Rick Kuhl <RKuhl@wskfarch.com>
Subject: Re: Columbus Fire Station #2

Matt,

I have attached a link to a cheaper option [here](#). The fixture comes in 1' increments which is pretty typical for undercabinet lights so they would need to go with the 24" fixture especially if they are end-feeding it.

On Thu, Apr 6, 2023 at 8:42 AM Matt McCaffrey <MMcCaffrey@wskfarch.com> wrote:

Antonio_

A question came up regarding the Type U light fixtures, the under-cabinet fixtures in the Kitchen. They were scheduled to be 48" long, but we never had cabinets that long. There are only two cabinets and they are 38" and 36" wide. The submittal was never marked up to reflect the needed width, so the 48" long fixtures were ordered. Those obviously are not going to work. For the electrician to order new fixtures, at the correct length, will be around \$700. Please advise on your thoughts on this issue. Would also like a recommendation for a potential cheaper fixture as we only have these two cabinets in the kitchen. Thank you.

Matt McCaffrey
senior project designer / bim manager



North Kansas City, MO
816.300.4101
Kansas City, KS
913.287.1900



ANTONIO McBEE
STAFF ENGINEER

P: 913.492.2400
EXT: 167
PKMRENG.COM

KANSAS CITY | TOPEKA | MANHATTAN | DENVER



Proposed Change Order

Number: 22-0093-10 PCO#10R1

3333 Folkways Cir
Lincoln, NE 68504
(402) 475-9151
FAX (402) 475-9186



To: B-D Construction Attn: Bryan Kearney	Phone: 402-564-1225	Fax: -	Date: 4/12/23
	Job Name/Location: Columbus Fire Station #2 Columbus, NE		

Change is per RFI#23R. Provide new type U fixtures. See attached breakdown.

Notes

- 1) **MATERIAL PROCUREMENT NOR INSTALLATION WILL BEGIN UNTIL A FULLY EXECUTED CHANGE ORDER HAS BEEN RECEIVED BY KIDWELL.**
- 2) Change does not include any patching, painting, or repair of any surface.
- 3) All work to be completed during Kidwell's normal business hours.
- 4) Change will impact schedule, and require 0 business day(s) time extension.
- 5) No sales tax has been included for material and labor in this proposal.
- 6) All other required taxes will be charged and added to the proposal price on invoicing.

NOTE: This Proposed Change Order is only good for 10 days due to the rising cost of commodities.
NOTE: This Proposed Change Order becomes part of and in conformance with the existing contract.

CONFIDENTIALITY NOTICE: *This proposal and/or change order and any attachments are strictly confidential and are intended solely for the use of the individual or entity to whom it is addressed. This communication may contain proprietary and financial data of Kidwell Inc. If you are not the intended recipient, be advised that any use, dissemination, forwarding, printing, or copying of this proposal and/or change order and any file attachments is strictly prohibited.*

We Agree hereby to make the change(s) specified above at this price **ADD \$402.00**
Four Hundred Two Dollars and 00/100 Cents.

Proposed Change Order Prepared By: <u>Brian Mostek</u>	PREVIOUS CONTRACT AMOUNT:
Authorized Kidwell Representative Signature: _____ (CONTRACTOR)	REVISED CONTRACT AMOUNT:

Payment will be made as follows: **MONTHLY**
*Accounts not paid within thirty days are subject to a finance charge of 1% monthly, and an annual rate of 12%.

Accepted- The above prices and specifications of the Change Order are satisfactory and are hereby accepted. All work to be performed under same terms and conditions as specified in original contract unless otherwise stipulated.	Authorized Signature: _____ (OWNER)
	Date of Acceptance: _____



DATE:

3/18/2023

ESTIMATED BY:

Brian M.

NAME OF PROJECT:

Columbus Fire Department - Fire Station #2

CHECKED BY:

LG

BID DESC:

PCO#10R1

COST ITEM	Qty.	Material Unit	Material Totals	Labor Unit	Labor MHS
1. Electrical Fixtures			0.00		0.00
2. Material Staging/Handling			0.00		0.00
		0.00	0.00	0.000	0.00
HU1124D9SP	2	53.31	106.62	0.000	0.00
		0.00	0.00	0.000	0.00
FREIGHT	1	75.00	75.00	0.000	0.00
		0.00	0.00	0.000	0.00
		0.00	0.00	0.000	0.00
		0.00	0.00	0.000	0.00
		0.00	0.00	0.000	0.00
		0.00	0.00	0.000	0.00
		0.00	0.00	0.000	0.00
		0.00	0.00	0.000	0.00
3. Miscellaneous (list items)			0.00		0.00
Total Items (1) thru (3) and Labor MH'S			181.62		0.00

4) Labor

a) Total MH'S			0.00	
b) Paid Holiday's Factor			0.00	
c) Productivity Factor			0.00	
d) Height Adj. Factor			0.00	
e) Job Cond. Factor			0.00	
Adjusted MH'S			0.00	
f)	0	MH'S Field Staff	78.60	0.00
g)	1	MH'S Project Mgr.	86.40	86.40
h)	1	MH'S Superintendant	79.80	79.80
i) Sub-Total Labor			166.20	
j) Material Tax		0.00 %		0.00
Total Items a-j				166.20

5) Subcontracts

a)	
b)	
c)	
d)	
e)	
f)	
g)	

Total Cost Item 5	0.00
--------------------------	------

6) Other Costs

a)	
b)	
c)	
d)	
e)	

Total Cost Item 6	0.00
--------------------------	------

Total Cost Item 1 thru 6			\$347.82
Job Overhead Cost			
Add or deduct sheet			
Total Prime Cost			\$347.82
Overhead	10	%	\$34.78
Total Cost			\$382.60
Profit	5	%	\$19.13
Sub-Total Selling			\$401.73
Bond	0	%	\$0.00
Total Selling Price			\$402.00

DESCRIPTION

Ideal for task, accent, office, cove, and utility, under and above cabinet lighting display, the Halo Undercabinet low-profile design delivers maximum energy savings with easy installation. Each fixture is equipped with a seleCCTable switch that allows users to customize color temperature of 2700K, 3000K and 4000K in 90 CRI. Fixtures are available in 9", 18", 24", 36" and 48" lengths with Matte White and Matte Black finishes. Each unit has an integrated on-off switch and offers smooth dimming down to 5% using standard dimmers**. Multiple wiring options make installation a simple task.

Catalog #		Type
Project		
Comments		Date
Prepared by		

SPECIFICATION FEATURES

Even Light Distribution

Specialized optical system consisting of tightly clustered proximity phosphor LEDs, advanced optical chamber coatings and lens materials resulting in soft illumination with high efficiency. These fixtures are ideal for task lighting.

Color Temperature

3 position external SeleCCTable color temperature switch allows users to choose between 2700K, 3000K, and 4000K and adjust per their lighting needs.

Wiring Flexibility

Use any combination of three different wiring methods: Bring flexible conduit or Romex directly to the 120V fixture. Conduit connector and romex strain relief hardware is included with each fixture. Otherwise users can utilize the available splice box and plug in connectors (sold separately) and to link additional fixtures to the circuit (See instructions sheets for more detail).* Link any combination of fixtures up to 450W total load using connectors.

Durable Low Profile Housing

Extruded aluminum housing and color matched end caps with a sleek over all height less than 1".

Mounting

Each unit is secured directly to the mounting surface with two integral fasteners keeping installation costs and efforts low. Can be mounted in horizontal and vertical orientations.

Optional Accessories

Optional splice box has a connection port on each side to allow for runs in either or both directions. Includes Romex/ 1/2" conduit connector. Various connector cable options and lengths provide flexibility of mounting location.

Finish Options

Fixtures and accessories are available in both White (P) and Matte Black (MB) finishes.

Electronic Driver & Dimming

Electronic driver provides flicker free light output and noise free operation. Designed for continuous dimming (ELV or TRIAC) down to 5% with compatible dimmers.**

Compliance & Certifications

- cULus listed
- Can be used to meet IECC, ASHRAE commercial and residential standards
- FCC Class B residential
- Damp location listed
- ENERGY STAR® certified
- Title 24
- Closet-Rated

Factory Defaults

The fixtures are factory pre-set to 3000K.

Warranty

Five-year limited warranty, consult website for details.
www.cooperlighting.com



HU11

Value LED Undercabinet



2700K • 3000K • 4000K

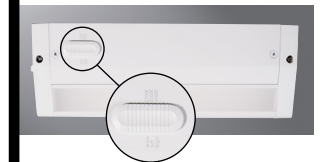

DIMENSIONS

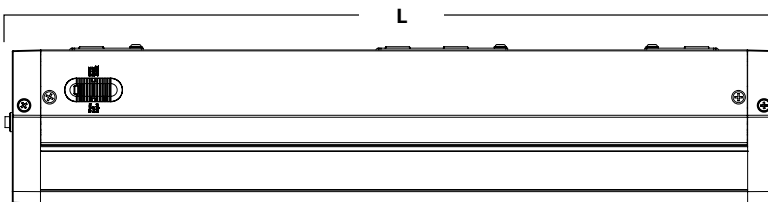

Size Description	9 in. Nominal	18 in. Nominal	24 in. Nominal	36 in. Nominal	48 in. Nominal
Length "L"	8.98" [228.1mm]	16.55" [420.4mm]	23.98" [609.1mm]	32.44" [824mm]	47.18" [1,198.4mm]
Wattage	4.5	8.0	11.0	15.5	21.0
Lumens***	300	560	785	1125	1540

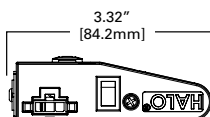
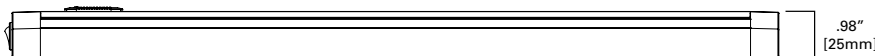

ENERGY DATA

Power Factor: >0.9
THD: <20%
Color Temperature: SeleCCTable
2700K, 3000K, 4000K
Color Rendering Index: 90
Nominal Lumens/Ft: 300



Can be used to comply with California Title 24 High Efficacy requirements. Certified to California Appliance Efficiency Database under JAB.

* Plug in wire option is only available on either end (side) of the fixture. Back wire option is for romex or flexible conduit wiring only.

** See our website for dimming guidance information. www.cooperlighting.com

*** Performance metrics are measured at 3000K. The factory setting is 3000K.

ORDERING INFORMATION

SAMPLE NUMBER: HU1118D9SP (18 inch Dimmable fixture, SeleCCTable Color temperature, White Finish)

Family	Length	Dimming	Color Temperature	Finish
HU11 =Halo Integrated Undercabinet	09=9" 18=18" 24=24" 36=36" 48=48"	D9=Dimmable	S=Selectable (2700K, 3000K, 4000K)	P=White MB=Matte Black

1. 9" cannot be linked with direct-wire. Requires daisy chain connector accessory.

CONNECTORS & ACCESSORIES



HU101
3" Daisy Chain Connector



HU102
6" Daisy Chain Connector



HU1010
12" Daisy Chain Connector

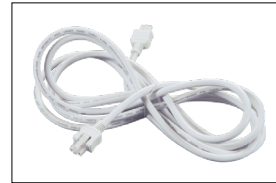

HU1011
18" Daisy Chain Connector



HU103
24" Daisy Chain Connector

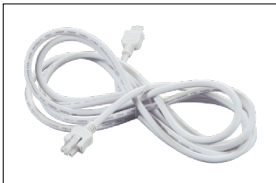

HU104
120" Daisy Chain Connector



HU115
48" Power Cord - 120V only



HU109
Splice Box



HU107
1-1/2" Male-to-Male Connector

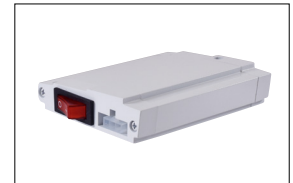

HU10MS
Master Switch

Finish: P = White; MB = Matte Black **Example:** HU101P = 3" Daisy Chain Connector, White

PHOTOMETRY

Fixture Application Illustration

MOUNTING HEIGHT 18"

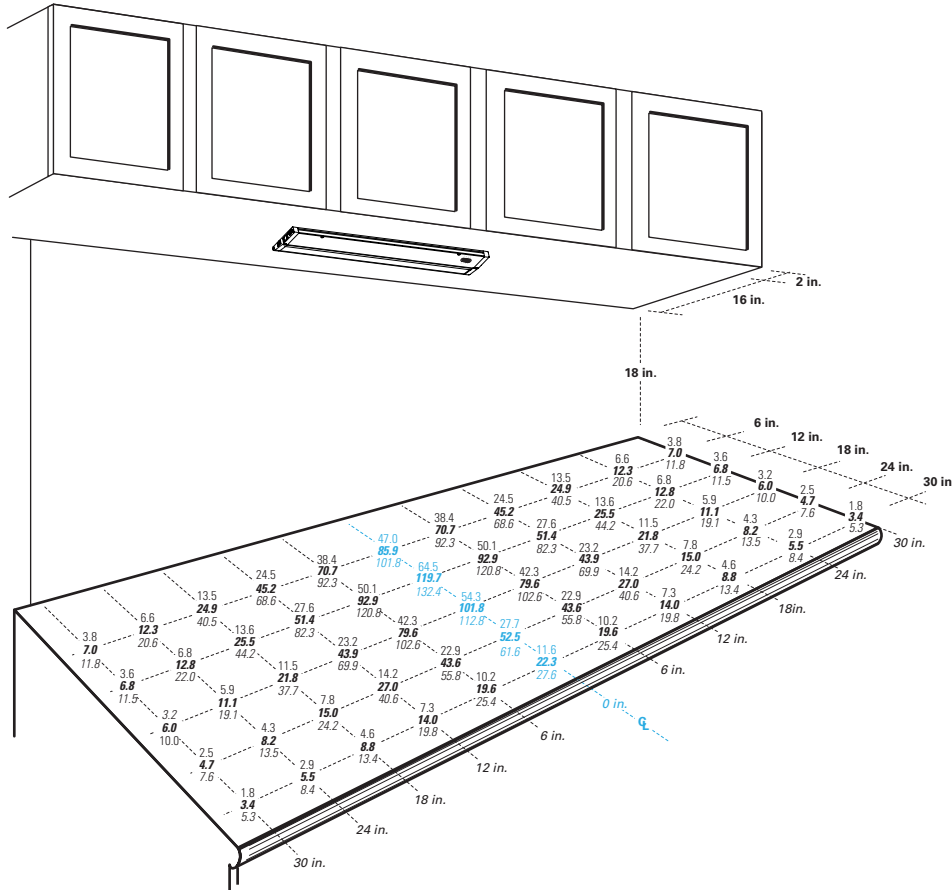

Top Number Report: HU1109D9SMB-3000K.IES
 Middle Number Report: HU1118D9SMB-3000K.IES
 Bottom Number Report: HU1124D9SMB-3000K.IES

Countertop 60" x 30"

Diagram not to scale.

18" Mounting Height

Top Number Report - HU1109D9SMB-3000K
 Middle Number Report - HU1118D9SMB-3000K
 Bottom Number Report - HU1124D9SMB-3000K

Width											Length
30in	24in	18in	12in	6in	0in	6in	12in	18in	24in	30in	
3.8	6.6	13.5	24.5	38.4	47.0	38.4	24.5	13.5	6.6	3.8	6 in
7.0	12.3	24.9	45.2	70.7	85.9	70.7	45.2	24.9	12.3	7.0	
11.8	20.6	40.5	68.6	92.3	101.8	92.3	68.6	40.5	20.6	11.8	12 in
3.6	6.8	13.6	27.6	50.1	64.5	50.1	27.6	13.6	6.8	3.6	
6.8	12.8	25.5	51.4	92.9	119.7	92.9	51.4	25.5	12.8	6.8	18 in
11.5	22.0	44.2	82.3	120.8	132.4	120.8	82.3	44.2	22.0	11.5	
3.2	5.9	11.5	23.2	42.3	54.3	42.3	23.2	11.5	5.9	3.2	24 in
6.0	11.1	21.8	43.9	79.6	101.8	79.6	43.9	21.8	11.1	6.0	
10.0	19.1	37.7	69.9	102.6	112.8	102.6	69.9	37.7	19.1	10.0	30 in
2.5	4.3	7.8	14.2	22.9	27.7	22.9	14.2	7.8	4.3	2.5	
4.7	8.2	15.0	27.0	43.6	52.5	43.6	27.0	15.0	8.2	4.7	6 in
7.6	13.5	24.2	40.6	55.8	61.6	55.8	40.6	24.2	13.5	7.6	
1.8	2.9	4.6	7.3	10.2	11.6	10.2	7.3	4.6	2.9	1.8	12 in
3.4	5.5	8.8	14.0	19.6	22.3	19.6	14.0	8.8	5.5	3.4	
5.3	8.4	13.4	19.8	25.4	27.6	25.4	19.8	13.4	8.4	5.3	18 in

15" Mounting Height

Top Number Report - HU1109D9SMB-3000K
 Middle Number Report - HU1118D9SMB-3000K
 Bottom Number Report - HU1124D9SMB-3000K

Width											Length
30in	24in	18in	12in	6in	0in	6in	12in	18in	24in	30in	
3.0	5.5	12.0	23.8	41.7	54.2	41.7	23.8	12.0	5.5	3.0	6 in
5.6	10.2	22.2	43.8	76.6	99.2	76.6	43.8	22.2	10.2	5.6	
9.7	17.9	37.9	70.6	100.8	111.3	100.8	70.6	37.9	17.9	9.7	12 in
2.9	5.7	12.4	28.6	63.0	90.4	63.0	28.6	12.4	5.7	2.9	
5.4	10.7	23.0	53.3	116.9	167.5	116.9	53.3	23.0	10.7	5.4	18 in
9.4	19.4	43.8	96.7	156.1	168.3	156.1	96.7	43.8	19.4	9.4	
2.5	4.8	10.3	23.7	51.9	73.9	51.9	23.7	10.3	4.8	2.5	24 in
4.7	9.2	19.4	44.9	98.2	139.4	98.2	44.9	19.4	9.2	4.7	
8.1	16.6	36.8	80.4	129.5	139.9	129.5	80.4	36.8	16.6	8.1	30 in
1.9	3.4	6.6	13.2	23.8	30.3	23.8	13.2	6.6	3.4	1.9	
3.6	6.6	12.7	25.1	45.4	57.8	45.4	25.1	12.7	6.6	3.6	6 in
6.0	11.2	21.7	40.2	58.4	64.5	58.4	40.2	21.7	11.2	6.0	
1.4	2.2	3.6	6.1	8.9	10.4	8.9	6.1	3.6	2.2	1.4	12 in
2.6	4.2	7.0	11.6	17.3	20.1	17.3	11.6	7.0	4.2	2.6	
4.0	6.6	10.9	16.9	22.3	24.4	22.3	16.9	10.9	6.6	4.0	18 in

Cooper Lighting Solutions is a registered trademark.

All other trademarks are property of their respective owners.

Product availability, specifications, and compliances are subject to change without notice.



Cooper Lighting Solutions
 1121 Highway 74 South
 Peachtree City, GA 30269
 P: 770-486-4800
 www.cooperlighting.com

© 2021 Cooper Lighting Solutions
 All Rights Reserved
 Printed in USA
 Publication No. TD518359EN
 February 2, 2021 1:30 PM



2154 E. 32nd Avenue
 Columbus, NE 68601
 (Phone) 402-564-1225
 (Fax) 402-564-9999

CHANGE ORDER PROPOSAL

NO. 018

PROJECT: Columbus Fire Station #2
COP NO.: 018

DATE QUOTED: 04/12/23

PROJECT NO.: 22-024

ARCH. PROJECT NO.: A-1588

TO: Rick Kuhl
 WSKF Architects Inc.
 110 Armour Road
 North Kansas City, MO 64116
 (Phone) 816.300.4101 (Fax) 816.300.4102

DAYS ALLOWED FOR APPROVAL:
EXPIRATION DATE: 04/12/23
REQUESTED EXTENSION OF TIME IN DAYS:

DESCRIPTION:

Per RFI#23, the existing Type U Undercabinet Lights that were specified will not work due to them being longer than the allowable space provided.

New Lighting was specified for replacement of these fixtures.

SUBCONTRACTORS / VENDORS	SUB / VENDOR WORK DESCRIPTION	AMOUNT:
Kidwell Electric	Electrical	\$402.00

B-D Construction, Inc.	5% Mark Up on Sub Contractors	\$20.10
B-D Construction, Inc.	Project Manager COP Processing	\$125.00

APPROVAL

TOTAL FROM WORK BREAKDOWN PAGES

NAME: _____	BOND: 1.2%	SUB SUBTOTAL: \$547.10
DATE: _____		\$6.57
SEND COPIES TO		\$0.00
B-D Construction, Inc., Bryan Kearney		\$0.00
WSKF Architects Inc., Rick Kuhl		
City of Columbus, Rick Bogus	SUBTOTAL:	\$553.67
B-D CONSTRUCTION, INC.		
BY: <i>Bryan L. Kearney</i>	SUBTOTAL:	\$553.67
Bryan Kearney, Project Manager		\$0.00
DATE: 4/12/23	TOTAL COP AMOUNT:	\$553.67



B-D Construction, Inc.
 2154 East 32nd Avenue
 Columbus, Nebraska 68601
 P: (402) 564-1225
 F: (402) 564-9999

**Project: 22-024 Columbus Fire Station #2
 Renovation & Expansion- Charlie Louis**
 424 8th Street
 Columbus, Nebraska 68601
 P: 402-564-1225
 F: 402-564-9999

RFI #23: Type U Fixture Length

Status	Open		
To	Matt McCaffrey (Williams Spurgeon Kuhl & Freshnock Architects, Inc.)	From	Bryan Kearney (B-D Construction, Inc.) 4032 60th STREET COLUMBUS, Nebraska 68601
Date Initiated	Mar 13, 2023	Due Date	Mar 16, 2023
Location		Project Stage	Course of Construction
Cost Impact		Schedule Impact	Yes (Unknown)
Spec Section	260000 - Electrical	Cost Code	
Drawing Number	E101	Reference	
Linked Drawings			
Received From	Levi Griffis (Kidwell)		
Copies To	Levi Griffis (Kidwell), Kevin Rubeck (B-D Construction, Inc.)		

Activity

Question

Question from Bryan Kearney B-D Construction, Inc. on Monday, Mar 13, 2023 at 01:53 PM CDT

The type U fixtures shown next to the range in Kitchen 108 are called out to be 48" long. The cabinets are not wide enough for these fixtures to work. We would need to order 24" long fixtures for them to fit under the current cabinets. Please advise.

Awaiting an Official Response

I am in agreement with the HUC523 on the smaller cabinet. Please verify with the light fixture manufacturer to see if the HUC535 will fit within the as-built space. If not, then please proceed with the HUC523. Also, apologies for forgetting about the cabinet size changes.

WSKF Architects
 Matt McCaffrey.



FIXTURE	NOMINAL LENGTH (FT)	ACTUAL LENGTH (IN)	LENGTH WITH LINKING CONNECTORS (IN)	MOUNTING LENGTH (IN)	SIDE EDGE TO KEYHOLE CENTER (IN)	BACK EDGE TO KEYHOLE CENTER (IN)	FIXTURE WEIGHT
HUC512	1	12.07	12.63	9	1.54	2.61	2.1 LBS
HUC519	1.5	19	19.56	12.92	3.04	2.62	3.2 LBS
HUC523	2	23.15	23.71	17	3.08	2.63	3.7 LBS
HUC535	3	34.9	35.46	28	3.45	2.63	5.7 LBS
HUC546	4	46.19	46.75	40	3.09	2.7	7.3 LBS

Bryan Kearney

From: Matt McCaffrey <MMcCaffrey@wskfarch.com>
Sent: Monday, April 10, 2023 10:37 AM
To: Bryan Kearney
Subject: FW: Columbus Fire Station #2

Bryan_

Please see the link below for a replacement undercabinet fixture. Please have your electrician review and advise. Thank you.

Matt McCaffrey
WSKF, Inc.
P.816.300.4101 F.816.300.4102 www.wskfarch.com

From: Antonio McBee <antonio.mcbee@pkmreng.com>
Sent: Friday, April 7, 2023 4:46 PM
To: Matt McCaffrey <MMcCaffrey@wskfarch.com>
Cc: Mike Raaf <mike.raaf@pkmreng.com>; Kevin Zimmerman <kevin.zimmerman@pkmreng.com>; Rick Kuhl <RKuhl@wskfarch.com>
Subject: Re: Columbus Fire Station #2

Matt,

I have attached a link to a cheaper option [here](#). The fixture comes in 1' increments which is pretty typical for undercabinet lights so they would need to go with the 24" fixture especially if they are end-feeding it.

On Thu, Apr 6, 2023 at 8:42 AM Matt McCaffrey <MMcCaffrey@wskfarch.com> wrote:

Antonio_

A question came up regarding the Type U light fixtures, the under-cabinet fixtures in the Kitchen. They were scheduled to be 48" long, but we never had cabinets that long. There are only two cabinets and they are 38" and 36" wide. The submittal was never marked up to reflect the needed width, so the 48" long fixtures were ordered. Those obviously are not going to work. For the electrician to order new fixtures, at the correct length, will be around \$700. Please advise on your thoughts on this issue. Would also like a recommendation for a potential cheaper fixture as we only have these two cabinets in the kitchen. Thank you.

Matt McCaffrey
senior project designer / bim manager



North Kansas City, MO
816.300.4101
Kansas City, KS
913.287.1900



ANTONIO McBEE
STAFF ENGINEER

P: 913.492.2400
EXT: 167
PKMRENG.COM

KANSAS CITY | TOPEKA | MANHATTAN | DENVER



Proposed Change Order

Number: 22-0093-10 PCO#10R1

3333 Folkways Cir
Lincoln, NE 68504
(402) 475-9151
FAX (402) 475-9186



To: B-D Construction Attn: Bryan Kearney	Phone: 402-564-1225	Fax: -	Date: 4/12/23
	Job Name/Location: Columbus Fire Station #2 Columbus, NE		

Change is per RFI#23R. Provide new type U fixtures. See attached breakdown.

Notes

- 1) **MATERIAL PROCUREMENT NOR INSTALLATION WILL BEGIN UNTIL A FULLY EXECUTED CHANGE ORDER HAS BEEN RECEIVED BY KIDWELL.**
- 2) Change does not include any patching, painting, or repair of any surface.
- 3) All work to be completed during Kidwell's normal business hours.
- 4) Change will impact schedule, and require 0 business day(s) time extension.
- 5) No sales tax has been included for material and labor in this proposal.
- 6) All other required taxes will be charged and added to the proposal price on invoicing.

NOTE: This Proposed Change Order is only good for 10 days due to the rising cost of commodities.
NOTE: This Proposed Change Order becomes part of and in conformance with the existing contract.

CONFIDENTIALITY NOTICE: *This proposal and/or change order and any attachments are strictly confidential and are intended solely for the use of the individual or entity to whom it is addressed. This communication may contain proprietary and financial data of Kidwell Inc. If you are not the intended recipient, be advised that any use, dissemination, forwarding, printing, or copying of this proposal and/or change order and any file attachments is strictly prohibited.*

We Agree hereby to make the change(s) specified above at this price **ADD \$402.00**
Four Hundred Two Dollars and 00/100 Cents.

Proposed Change Order Prepared By: <u>Brian Mostek</u>	PREVIOUS CONTRACT AMOUNT:
Authorized Kidwell Representative Signature: _____ (CONTRACTOR)	REVISED CONTRACT AMOUNT:

Payment will be made as follows: **MONTHLY**
*Accounts not paid within thirty days are subject to a finance charge of 1% monthly, and an annual rate of 12%.

Accepted- The above prices and specifications of the Change Order are satisfactory and are hereby accepted. All work to be performed under same terms and conditions as specified in original contract unless otherwise stipulated.	Authorized Signature: _____ (OWNER)
	Date of Acceptance: _____



DATE:

3/18/2023

ESTIMATED BY:

Brian M.

NAME OF PROJECT:

Columbus Fire Department - Fire Station #2

CHECKED BY:

LG

BID DESC:

PCO#10R1

COST ITEM	Qty.	Material Unit	Material Totals	Labor Unit	Labor MHS
1. Electrical Fixtures			0.00		0.00
2. Material Staging/Handling			0.00		0.00
		0.00	0.00	0.000	0.00
HU1124D9SP	2	53.31	106.62	0.000	0.00
		0.00	0.00	0.000	0.00
FREIGHT	1	75.00	75.00	0.000	0.00
		0.00	0.00	0.000	0.00
		0.00	0.00	0.000	0.00
		0.00	0.00	0.000	0.00
		0.00	0.00	0.000	0.00
		0.00	0.00	0.000	0.00
		0.00	0.00	0.000	0.00
		0.00	0.00	0.000	0.00
3. Miscellaneous (list items)			0.00		0.00
Total Items (1) thru (3) and Labor MH'S			181.62		0.00

4) Labor

a) Total MH'S			0.00	
b) Paid Holiday's Factor			0.00	
c) Productivity Factor			0.00	
d) Height Adj. Factor			0.00	
e) Job Cond. Factor			0.00	
Adjusted MH'S			0.00	
f)	0	MH'S Field Staff	78.60	0.00
g)	1	MH'S Project Mgr.	86.40	86.40
h)	1	MH'S Superintendant	79.80	79.80
i) Sub-Total Labor			166.20	
j) Material Tax		0.00 %		0.00
Total Items a-j				166.20

5) Subcontracts

a)	
b)	
c)	
d)	
e)	
f)	
g)	

Total Cost Item 5	0.00
--------------------------	------

6) Other Costs

a)	
b)	
c)	
d)	
e)	

Total Cost Item 6	0.00
--------------------------	------

Total Cost Item 1 thru 6			\$347.82
Job Overhead Cost			
Add or deduct sheet			
Total Prime Cost			\$347.82
Overhead	10	%	\$34.78
Total Cost			\$382.60
Profit	5	%	\$19.13
Sub-Total Selling			\$401.73
Bond	0	%	\$0.00
Total Selling Price			\$402.00

DESCRIPTION

Ideal for task, accent, office, cove, and utility, under and above cabinet lighting display, the Halo Undercabinet low-profile design delivers maximum energy savings with easy installation. Each fixture is equipped with a seleCCTable switch that allows users to customize color temperature of 2700K, 3000K and 4000K in 90 CRI. Fixtures are available in 9", 18", 24", 36" and 48" lengths with Matte White and Matte Black finishes. Each unit has an integrated on-off switch and offers smooth dimming down to 5% using standard dimmers**. Multiple wiring options make installation a simple task.

Catalog #		Type
Project		
Comments		Date
Prepared by		

SPECIFICATION FEATURES

Even Light Distribution

Specialized optical system consisting of tightly clustered proximity phosphor LEDs, advanced optical chamber coatings and lens materials resulting in soft illumination with high efficiency. These fixtures are ideal for task lighting.

Color Temperature

3 position external SeleCCTable color temperature switch allows users to choose between 2700K, 3000K, and 4000K and adjust per their lighting needs.

Wiring Flexibility

Use any combination of three different wiring methods: Bring flexible conduit or Romex directly to the 120V fixture. Conduit connector and romex strain relief hardware is included with each fixture. Otherwise users can utilize the available splice box and plug in connectors (sold separately) and to link additional fixtures to the circuit (See instructions sheets for more detail).* Link any combination of fixtures up to 450W total load using connectors.

Durable Low Profile Housing

Extruded aluminum housing and color matched end caps with a sleek over all height less than 1".

Mounting

Each unit is secured directly to the mounting surface with two integral fasteners keeping installation costs and efforts low. Can be mounted in horizontal and vertical orientations.

Optional Accessories

Optional splice box has a connection port on each side to allow for runs in either or both directions. Includes Romex/ 1/2" conduit connector. Various connector cable options and lengths provide flexibility of mounting location.

Finish Options

Fixtures and accessories are available in both White (P) and Matte Black (MB) finishes.

Electronic Driver & Dimming

Electronic driver provides flicker free light output and noise free operation. Designed for continuous dimming (ELV or TRIAC) down to 5% with compatible dimmers.**

Compliance & Certifications

- cULus listed
- Can be used to meet IECC, ASHRAE commercial and residential standards
- FCC Class B residential
- Damp location listed
- ENERGY STAR® certified
- Title 24
- Closet-Rated

Factory Defaults

The fixtures are factory pre-set to 3000K.

Warranty

Five-year limited warranty, consult website for details.
www.cooperlighting.com



HU11

Value LED Undercabinet



2700K • 3000K • 4000K

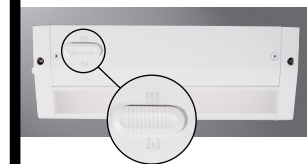

DIMENSIONS

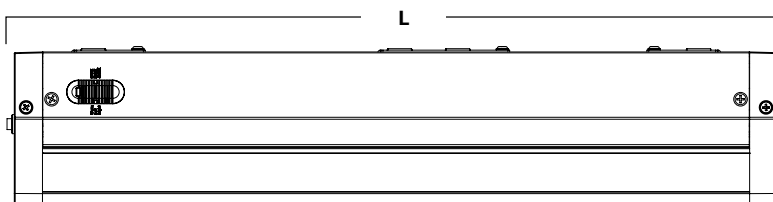

Size Description	9 in. Nominal	18 in. Nominal	24 in. Nominal	36 in. Nominal	48 in. Nominal
Length "L"	8.98" [228.1mm]	16.55" [420.4mm]	23.98" [609.1mm]	32.44" [824mm]	47.18" [1,198.4mm]
Wattage	4.5	8.0	11.0	15.5	21.0
Lumens***	300	560	785	1125	1540

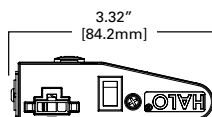
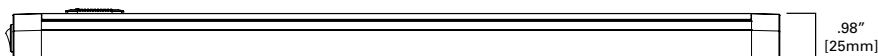

ENERGY DATA

Power Factor: >0.9
THD: <20%
Color Temperature: SeleCCTable
2700K, 3000K, 4000K
Color Rendering Index: 90
Nominal Lumens/Ft: 300



Can be used to comply with California Title 24 High Efficacy requirements. Certified to California Appliance Efficiency Database under JAB.

* Plug in wire option is only available on either end (side) of the fixture. Back wire option is for romex or flexible conduit wiring only.

** See our website for dimming guidance information. www.cooperlighting.com

*** Performance metrics are measured at 3000K. The factory setting is 3000K.

ORDERING INFORMATION

SAMPLE NUMBER: HU1118D9SP (18 inch Dimmable fixture, SeleCCTable Color temperature, White Finish)

Family	Length	Dimming	Color Temperature	Finish
HU11 =Halo Integrated Undercabinet	09=9" 18=18" 24=24" 36=36" 48=48"	D9=Dimmable	S=Selectable (2700K, 3000K, 4000K)	P=White MB=Matte Black

1. 9" cannot be linked with direct-wire. Requires daisy chain connector accessory.

CONNECTORS & ACCESSORIES



HU101
3" Daisy Chain Connector



HU102
6" Daisy Chain Connector

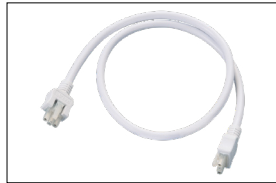

HU1010
12" Daisy Chain Connector



HU1011
18" Daisy Chain Connector



HU103
24" Daisy Chain Connector

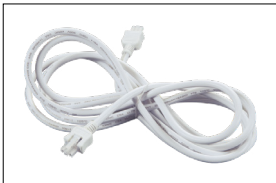

HU104
120" Daisy Chain Connector



HU115
48" Power Cord - 120V only



HU109
Splice Box



HU107
1-1/2" Male-to-Male Connector



HU10MS
Master Switch

Finish: P = White; MB = Matte Black **Example:** HU101P = 3" Daisy Chain Connector, White

PHOTOMETRY

Fixture Application Illustration

MOUNTING HEIGHT 18"

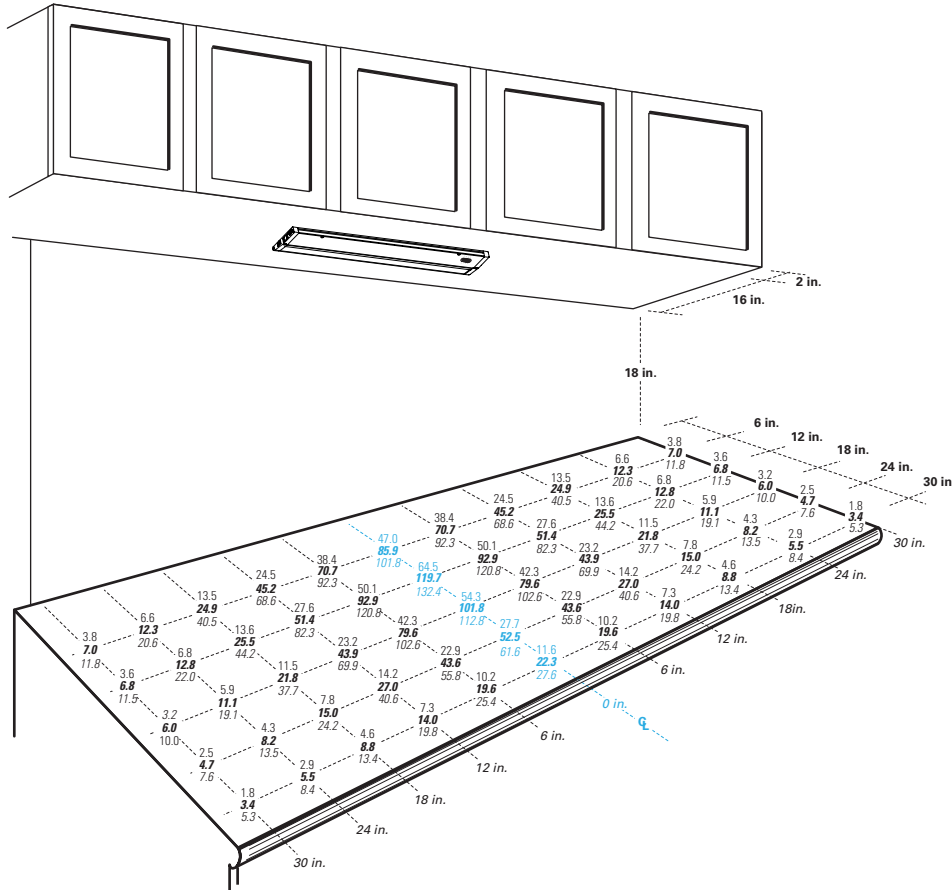

Top Number Report: HU1109D9SMB-3000K.IES
 Middle Number Report: HU1118D9SMB-3000K.IES
 Bottom Number Report: HU1124D9SMB-3000K.IES

Countertop 60" x 30"

Diagram not to scale.

18" Mounting Height

Top Number Report - HU1109D9SMB-3000K
 Middle Number Report - HU1118D9SMB-3000K
 Bottom Number Report - HU1124D9SMB-3000K

Width											Length
30in	24in	18in	12in	6in	0in	6in	12in	18in	24in	30in	
3.8	6.6	13.5	24.5	38.4	47.0	38.4	24.5	13.5	6.6	3.8	6 in
7.0	12.3	24.9	45.2	70.7	85.9	70.7	45.2	24.9	12.3	7.0	
11.8	20.6	40.5	68.6	92.3	101.8	92.3	68.6	40.5	20.6	11.8	
3.6	6.8	13.6	27.6	50.1	64.5	50.1	27.6	13.6	6.8	3.6	12 in
6.8	12.8	25.5	51.4	92.9	119.7	92.9	51.4	25.5	12.8	6.8	
11.5	22.0	44.2	82.3	120.8	132.4	120.8	82.3	44.2	22.0	11.5	
3.2	5.9	11.5	23.2	42.3	54.3	42.3	23.2	11.5	5.9	3.2	18 in
6.0	11.1	21.8	43.9	79.6	101.8	79.6	43.9	21.8	11.1	6.0	
10.0	19.1	37.7	69.9	102.6	112.8	102.6	69.9	37.7	19.1	10.0	
2.5	4.3	7.8	14.2	22.9	27.7	22.9	14.2	7.8	4.3	2.5	24 in
4.7	8.2	15.0	27.0	43.6	52.5	43.6	27.0	15.0	8.2	4.7	
7.6	13.5	24.2	40.6	55.8	61.6	55.8	40.6	24.2	13.5	7.6	
1.8	2.9	4.6	7.3	10.2	11.6	10.2	7.3	4.6	2.9	1.8	30 in
3.4	5.5	8.8	14.0	19.6	22.3	19.6	14.0	8.8	5.5	3.4	
5.3	8.4	13.4	19.8	25.4	27.6	25.4	19.8	13.4	8.4	5.3	

15" Mounting Height

Top Number Report - HU1109D9SMB-3000K
 Middle Number Report - HU1118D9SMB-3000K
 Bottom Number Report - HU1124D9SMB-3000K

Width											Length
30in	24in	18in	12in	6in	0in	6in	12in	18in	24in	30in	
3.0	5.5	12.0	23.8	41.7	54.2	41.7	23.8	12.0	5.5	3.0	6 in
5.6	10.2	22.2	43.8	76.6	99.2	76.6	43.8	22.2	10.2	5.6	
9.7	17.9	37.9	70.6	100.8	111.3	100.8	70.6	37.9	17.9	9.7	
2.9	5.7	12.4	28.6	63.0	90.4	63.0	28.6	12.4	5.7	2.9	12 in
5.4	10.7	23.0	53.3	116.9	167.5	116.9	53.3	23.0	10.7	5.4	
9.4	19.4	43.8	96.7	156.1	168.3	156.1	96.7	43.8	19.4	9.4	
2.5	4.8	10.3	23.7	51.9	73.9	51.9	23.7	10.3	4.8	2.5	18 in
4.7	9.2	19.4	44.9	98.2	139.4	98.2	44.9	19.4	9.2	4.7	
8.1	16.6	36.8	80.4	129.5	139.9	129.5	80.4	36.8	16.6	8.1	
1.9	3.4	6.6	13.2	23.8	30.3	23.8	13.2	6.6	3.4	1.9	24 in
3.6	6.6	12.7	25.1	45.4	57.8	45.4	25.1	12.7	6.6	3.6	
6.0	11.2	21.7	40.2	58.4	64.5	58.4	40.2	21.7	11.2	6.0	
1.4	2.2	3.6	6.1	8.9	10.4	8.9	6.1	3.6	2.2	1.4	30 in
2.6	4.2	7.0	11.6	17.3	20.1	17.3	11.6	7.0	4.2	2.6	
4.0	6.6	10.9	16.9	22.3	24.4	22.3	16.9	10.9	6.6	4.0	

Cooper Lighting Solutions is a registered trademark.

All other trademarks are property of their respective owners.

Product availability, specifications, and compliances are subject to change without notice.



Cooper Lighting Solutions
 1121 Highway 74 South
 Peachtree City, GA 30269
 P: 770-486-4800
 www.cooperlighting.com

© 2021 Cooper Lighting Solutions
 All Rights Reserved
 Printed in USA
 Publication No. TD518359EN
 February 2, 2021 1:30 PM



2154 E. 32nd Avenue
 Columbus, NE 68601
 (Phone) 402-564-1225
 (Fax) 402-564-9999

CHANGE ORDER PROPOSAL

NO. 019

PROJECT: Columbus Fire Station #2
COP NO.: 019

DATE QUOTED: 07/28/23

PROJECT NO.: 22-024

ARCH. PROJECT NO.: A-1588

TO: Rick Kuhl
 WSKF Architects Inc.
 110 Armour Road
 North Kansas City, MO 64116
 (Phone) 816.300.4101 (Fax) 816.300.4102

DAYS ALLOWED FOR APPROVAL:
EXPIRATION DATE: 07/28/23
REQUESTED EXTENSION OF TIME IN DAYS:

DESCRIPTION:

Supply and install Hose Reels in Apparatus Bay

SUBCONTRACTORS / VENDORS	SUB / VENDOR WORK DESCRIPTION	AMOUNT:
B-D Construction, Inc.	Hose Reel Supply	\$402.00
Obrist & Co.	Install Hose Reels and Connections	\$2,325.00

B-D Construction, Inc.	5% Mark Up on Sub Contractors	\$136.35
B-D Construction, Inc.	Project Manager COP Processing	\$125.00

APPROVAL

TOTAL FROM WORK BREAKDOWN PAGES

NAME: _____
DATE: _____

SUB SUBTOTAL: \$2,988.35
BOND: 1.2% \$35.86
 \$0.00
 \$0.00

SEND COPIES TO
 B-D Construction, Inc., Bryan Kearney
 WSKF Architects Inc., Rick Kuhl
 City of Columbus, Rick Bogus

SUBTOTAL: \$3,024.21

B-D CONSTRUCTION, INC.

BY: Bryan L. Kearney
 Bryan Kearney, Project Manager

SUBTOTAL: \$3,024.21
 \$0.00

DATE: 7/28/23

TOTAL COP AMOUNT: \$3,024.21



Final Details for Order #111-1397633-8002610

[Print this page for your records.](#)

Order Placed: June 16, 2023
Amazon.com order number: 111-1397633-8002610
Seller's order number: 12140982
Order Total: \$1,322.07

Shipped on June 16, 2023

Items Ordered

3 of: *Reelcraft A5850 OLP 1/2-Inch by 50-Foot Spring Driven Hose Reel for Air/Water*
Sold by: FastoolNow ([seller profile](#))
Supplied by: Other
Condition: New

Price
\$417.72

Shipping Address:

Bryan Kearney
2154 E 32ND AVE
COLUMBUS, NE 68601-7200
United States

Shipping Speed:

Standard Shipping

Payment information

Payment Method:

Visa | Last digits: 6405

Billing address

Bryan Kearney
2154 E 32ND AVE
COLUMBUS, NE 68601-7200
United States

Credit Card transactions

Item(s) Subtotal:	\$1,253.16
Shipping & Handling:	\$0.00

Total before tax:	\$1,253.16
Estimated tax to be collected:	\$68.91

Grand Total:	\$1,322.07

Visa ending in 6405: June 16, 2023: \$1,322.07

To view the status of your order, return to [Order Summary](#).

[Conditions of Use](#) | [Privacy Notice](#) © 1996-2023, Amazon.com, Inc. or its affiliates

Bryan Kearney

To: John Obrist
Subject: RE: Fire Station

Bryan Kearney
B-D Construction, Inc.
O: 402.564.1225 | C: 402.910.1306

From: John Obrist <john@obristandcompany.com>
Sent: Tuesday, July 18, 2023 10:04 AM
To: Bryan Kearney <bryank@bdconstructioninc.com>
Subject: RE: Fire Station

To run the and install the 3 hose reels provide by the Fire Department for the sum of \$2325.00.

Let me know if you want us to schedule the work.

Thanks,
John

From: John Obrist
Sent: Tuesday, July 18, 2023 7:19 AM
To: 'Bryan Kearney' <bryank@bdconstructioninc.com>
Subject: RE: Fire Station

I will have it to you today.

From: Bryan Kearney <bryank@bdconstructioninc.com>
Sent: Monday, July 17, 2023 10:27 AM
To: John Obrist <john@obristandcompany.com>
Subject: RE: Fire Station

John-
Checking back in on pricing for this change order?

Bryan Kearney
B-D Construction, Inc.
O: 402.564.1225 | C: 402.910.1306

From: Bryan Kearney
Sent: Friday, June 30, 2023 3:34 PM
To: john@obristandcompany.com
Subject: Fire Station

John-
Can you give me an add for installing the (3) Compressed Air Hose Reels.

Bryan Kearney

B-D Construction, Inc.

O: 402.564.1225 | C: 402.910.1306

14.B. Resolution No. R23-119 approving Change Order No. 2 with Boyd Jones Construction Company in the amount of \$395,666.60 for expansion of the east parking lot at Columbus Community Building to include lot at 1471 25th Avenue (former Columbus Rescue Mission).

RESOLUTION NO R23-119

A RESOLUTION OF THE MAYOR AND COUNCIL OF THE CITY OF COLUMBUS, NEBRASKA, APPROVING FORMER COLUMBUS RESCUE MISSION (1471 25 AVENUE) SITE IMPROVEMENTS CHANGE ORDER NO. 2 WITH BOYD JONES CONSTRUCTION COMPANY FOR EXTENSION OF THE COMMUNITY BUILDING PROJECT EAST PARKING LOT, IN THE AMOUNT OF \$395,666.60, FOR COMMUNITY BUILDING PROJECT

WHEREAS, Resolution No. R16-92 awarded the construction manager at risk, with Boyd Jones Construction Company, and with updated contact information in Resolution R20-142; and

WHEREAS, Resolution No. R21-131 established a guaranteed maximum price of \$26,201,578; and

WHEREAS, Resolution No. R22-77 approved Change Order No. 1; and

WHEREAS, Resolution No. R23-02 purchased the former Columbus Rescue Mission (1471 25 Avenue), N 1/2 of Lots 3 and 4, except the east 1 foot of Lot 3, Block 49, Original City of Columbus Platte County, Nebraska, for the purposes of expanding the Community Building project east parking lot; and

WHEREAS, Resolution No. R23-92 approved the Rural Business Development Grant for the purpose to use towards expanding the Community Building project east parking lot; and

WHEREAS, additional services and costs to the Boyd Jones Company guaranteed maximum price are required at the former Columbus Rescue Mission site property (1471 25 Avenue) for clearing, site preparation, earthwork, paving, storm sewer, utility adjustments and capping, lighting, conduits, landscaping, permitting, and related work and services; and

WHEREAS, city staff and representatives of Boyd Jones Construction Company and BVH Architecture discussed, evaluated, and reviewed said additional services and modifications; and

WHEREAS, Boyd Jones Construction Company has concurred on the proposed modifications as identified in Change Order No. 2.

NOW, THEREFORE, BE IT RESOLVED BY THE MAYOR AND COUNCIL OF THE CITY OF COLUMBUS, NEBRASKA, that former Columbus Rescue Mission (1471 25 Avenue) Site Improvements Change Order No. 2 with Boyd Jones Construction Company for extension of the Community Building project east parking lot, in the amount

of \$395,666.60, is approved and the mayor is authorized to sign on behalf of the City of Columbus.

INTRODUCED BY COUNCIL MEMBER _____

PASSED AND ADOPTED THIS ____ DAY OF _____, 2023.

MAYOR

ATTEST:

CITY CLERK

APPROVED AS TO FORM:

CITY ATTORNEY

M E M O R A N D U M

DATE: August 31, 2023
FROM : Richard Bogus, P.E. City Engineer
TO: Tara Vasicek, City Administrator
RE: Community Building Project, former Rescue Mission Property Site Improvements

RECOMMENDATION:

I recommend approval of Community Building project, former Rescue Mission property, site improvements, Change Order No. 2 with Boyd Jones Construction in the amount of \$395,666.60

DISCUSSION:

The use of a change order is the contract agreement method used to include additional work and services to the existing contract, subcontracts, insurance, and providing for the continuation of work with the general contractor on the construction site. This is not a change order to the original Community Building project site as that was completed within the guaranteed maximum price budget. This change order is for the additional work and services for the Community Building project expansion of the east parking lot as discussed and approved by the City Council in resolutions and in budget hearings and meetings.

As a reminder of the timeline on this work thus far, the guaranteed maximum price was approved by Resolution R21-131 in October 2021. The purchase of the Rescue Mission for the purpose of extending the east parking lot on this project was approved by Resolution R23-02 in January 2023. The Rural Development Grant for the purposes of cost assistance for the east parking lot expansion on this project was approved by Resolution R23-92 in July 2023. The 2023-2024 fiscal year budget includes capital improvement project No. 24-02 funding for the expansion of the east parking lot.

The expansion of the Community Building east parking lot includes, but is not limited to: removals of former Rescue Mission building and foundations; garage and outbuilding foundations; removal of street, driveway, and sidewalk pavement; removal of large and medium sized trees; removal of vegetation and topsoil; construction of concrete parking lot, streets, and sidewalks; paint striping; ADA signage; construction of storm sewer piping and inlets; construction of electrical lighting, conduits, and wiring for the parking lot; construction of future conduits with pull strings; capping multiple water and sanitary sewer service at the mains; adjusting utilities to grade; plantings of vegetation; placing of landscape and groundcover; underground sprinklers, and related work. Costs also included additional builder's risk insurance, security fencing, traffic and pedestrian control, Nebraska Department of Environment and Energy Construction Stormwater Notice of Intent and Storm Water Pollution Protection Plan, Stormwater Pollution Prevention Plan, construction layout and staking, geotechnical soil testing, and related services.

Boyd Jones provided estimates of costs which are in line with equivalent size of work and services on this project. Subcontractor early 2021 established unit prices were used where

applicable. The costs were evaluated and checked a number of ways. 1) Boyd Jones obtained a cost check from a subcontractor not on the project, which was higher than the project subcontractor, BD Construction. 2) BVH Architects, the project architects, have reviewed the change order and have recommended approval by the City. 3) The Engineering Department used recent past bids to estimate the costs and found the costs to be in order. 4) Boyd Jones estimated the early 2021 quotes from the City Hall property parking improvements work (ranged from \$800,000 to \$1,000,000) and used it with the inflation factor to compare with this change order work and found it be within range. 5) Boyd Jones broke it down further and estimated the early 2021 quotes for such items as building demolition, foundation removal, site concrete removal, earthwork, tree removal, and testing for the City Hall property (ranged from \$300,000 to \$362,000) and used it with the inflation factor to compare with this change order equivalent work and found it be within range.

The cost for the former Rescue Mission property site improvements should be less since the City Hall property as it is about one-third in size and building stature. It is also of note that the original costs were obtained about 2 -1/2 years earlier than now. As the City Council has seen on other materials and project bids over the past 2- 1/2 years, the costs have dramatically increased.

If the City Council were to not proceed with this work at this time, the expanded east parking lot work would then have to be re-designed and go through a bid-build process in 2024. The cost estimate to hold off on these improvements until 2024 increases the cost to an estimated range of \$480,000 to \$510,000. The projected cost increase is due mainly to increased material and labor costs and construction inflation and re-bidding of the 2021 established unit prices. In addition, the need for contractors to re-mobilize, obtain an additional construction stormwater permit and features, reset the site security fencing and signage, reset street and sidewalk barricading, obtain additional insurance, and similar project requirements which are in place at this time. A rebid does not take into account a delay to the constituents using City Hall, Library, and Children's Museum.

FISCAL IMPACT:

Change order amount of \$395,666.60. 2023-2024 budget CIP 24-02 in the amount of \$200,000 and sale of former Police Station/Temporary Library in the amount of \$142,600. The Rural Development Grant amount is \$99,999.

ALTERNATIVE:

Do not approve, resulting in the need to re-design and bid-build in 2024.

SIGNATURE:

By: Richard J. Bogue

Approved By: [Signature]



PCCO #02

Boyd Jones Construction
 950 South 10th Street, Suite 100
 Omaha, Nebraska 68108
 Phone: (402) 553-1804
 Fax: (402) 561-7705

Project: 16-026 - Columbus Community Center
 2500 14th Street
 Columbus, Nebraska 68601

Prime Contract Change Order #02: Rescue Mission demo/paving PR #86/86R

TO:	City of Columbus, NE 2424 14th Street Columbus, Nebraska 68602	FROM:	Boyd Jones Construction Company 950 South 10th Street, Suite 100 Omaha, Nebraska 68108
DATE CREATED:	7/12/2023	CREATED BY:	Scott Brown (Boyd Jones Construction Company)
CONTRACT STATUS:	Pending - In Review	REVISION:	0
DESIGNATED REVIEWER:		REVIEWED BY:	
DUE DATE:		REVIEW DATE:	
INVOICED DATE:		PAID DATE:	
SCHEDULE IMPACT:		EXECUTED:	No
		SIGNED CHANGE ORDER RECEIVED DATE:	
CONTRACT FOR:	1:Columbus Civic Center Prime Contract	TOTAL AMOUNT:	\$395,666.60

DESCRIPTION:

Add the work for demolition of the Rescue Mission and add parking lot paving as noted on PR numbers 86 & 86R

ATTACHMENTS:**CHANGE ORDER REQUESTS IN THIS CHANGE ORDER:**

COR #	Title	Schedule Impact	Amount
02	Rescue Mission		\$395,666.60
Total:			\$395,666.60

POTENTIAL CHANGE ORDERS IN THIS CHANGE ORDER:

PCO #	Title	Schedule Impact	Amount
047	CE #174 - Rescue mission work		\$395,666.60
Total:			\$395,666.60

CHANGE ORDER LINE ITEMS:**PCO # 047: CE #174 - Rescue mission work**

#	Budget Code	Description	Amount
1	1-501.L Layout - BJC Forces.Labor	Layout	\$3,500.00
2	1-502.S Surveying - Subcontractor.Sub Contracts	Professional Surveying	\$4,500.00
3	1-601.EW Skidloader.Equipment Weekly	Skidloader	\$4,250.00
4	1-615.EW Street Cleaning.Equipment Weekly	Sweeper	\$625.00
5	1-615.L Street Cleaning.Labor	Street sweeping labor	\$1,890.72
6	2-270.L Erosion Control.Labor	Erosion control maint	\$1,260.48
7	1-630.S Temporary Fence.Sub Contracts	Temp fence	\$4,000.00
8	1-625.O Barricades.Other	Barricades	\$1,500.00
9	2-270.O Erosion Control.Other	SWPPP Sign	\$500.00
10	2-090.S Site Preparation and Demolitio.Sub Contracts	Demolition/grading	\$219,801.35

#	Budget Code	Description	Amount
11	2-530.S Pavement Striping.Sub Contracts	Striping, sealants, signs	\$4,280.00
12	2-660.S Site Utilities.Sub Contracts	Storm drain	\$22,900.00
13	2-850.S Irrigation Systems.Sub Contracts	Irrigation system	\$4,280.00
14	2-850.E Irrigation Systems.Equipment	Irrigation sleeves	\$500.00
15	2-900.S Landscaping.Sub Contracts	Landscaping	\$5,026.64
16	3-340.S Slab on Grade Concrete.Sub Contracts	Concrete	\$51,843.14
17	7-900.S Joint Sealers.Sub Contracts	Sealants	\$995.00
18	16-010.S Electrical.Sub Contracts	Electrical	\$11,173.00
19	1-022.O Travel - Mileage.Other	Mileage	\$1,000.00
20	1-023.O Per Diem.Other	Per Diem	\$500.00
21	1-101.L Superintendent.Labor	Supervision	\$10,000.00
22	1-018.O Contractor's Contingency.Other	Contingency	\$12,500.00
23	2-660.S Site Utilities.Sub Contracts	Cut and Cap Utilities allowance	\$10,000.00
Subtotal:			\$376,825.33
Overhead and profit (5.00% Applies to all line item types.):			\$18,841.27
Grand Total:			\$395,666.60

The original (Contract Sum)	\$26,201,578.00
Net change by previously authorized Change Orders	\$126,518.15
The contract sum prior to this Change Order was	\$26,328,096.15
The contract sum would be changed by this Change Order in the amount of	\$395,666.60
The new contract sum including this Change Order will be	\$26,723,762.75
The contract time will not be changed by this Change Order.	

**(Bahr Vermeer Haecker
(BVH) Architects)**
440 No. 8th Street Suite 100
Lincoln, Nebraska 68508

City of Columbus, NE
2424 14th Street
Columbus, Nebraska 68602

Boyd Jones Construction Company
950 South 10th Street, Suite 100
Omaha, Nebraska 68108

SIGNATURE DATE 9/1/2023

SIGNATURE DATE

Scott Brown 
Digitally signed by Scott Brown
DN: C=US, E=sbrown@boydjones.biz,
O=Boyd Jones, CN=Scott Brown
Reason: I am approving this document
Date: 2023.08.30 14:45:58-05'00'
SIGNATURE DATE

14.C.Resolution No. R23-120 accepting proposal from BerganKDV for audit services.

RESOLUTION NO. R23-120

A RESOLUTION OF THE MAYOR AND COUNCIL OF THE CITY OF COLUMBUS, NEBRASKA, ACCEPTING THE PROPOSAL FROM BERGANKDV FOR AUDIT SERVICES FOR THE CITY OF COLUMBUS FOR FISCAL YEARS ENDING SEPTEMBER 30, 2023, 2024, AND 2025, A COPY OF WHICH IS ATTACHED HERETO AND INCORPORATED HEREIN BY THIS REFERENCE; AND TO AUTHORIZE THE MAYOR TO EXECUTE THE SAME ON BEHALF OF THE CITY OF COLUMBUS; AND TO REPEAL ALL RESOLUTIONS IN CONFLICT HEREWITH.

BE IT RESOLVED BY THE MAYOR AND COUNCIL OF THE CITY OF COLUMBUS, NEBRASKA, that the proposal from BergankDV for audit services for the City of Columbus, a copy of which is attached hereto and incorporated herein by this reference, is hereby accepted and the mayor is authorized, directed, and empowered to execute the same on behalf of the City of Columbus.

This resolution shall repeal all resolutions or portions thereof in conflict herewith.

INTRODUCED BY COUNCIL MEMBER _____

PASSED AND ADOPTED THIS ____ DAY OF _____, 2023.

MAYOR

ATTEST:

CITY CLERK

APPROVED AS TO FORM:

CITY ATTORNEY

MEMORANDUM

DATE: September 5, 2023

TO: Tara Vasicek, City Administrator

FROM: Heather Lindsley, Finance Director

SUBJECT: Audit Proposal

RECOMMENDATION: Staff recommends that the proposal from Bergan KDV, to audit our financial statements, for the next three years, be accepted.

DISCUSSION: Staff solicited proposals for the City of Columbus financial and compliance audit from all CPA firms advertising in the Columbus area, firms that had submitted proposals in prior years and firms that had requested to be notified. We only received one proposal. Bergan KDV audits several governmental units, namely Grand Island, Gretna, Hastings, Ashland and Bennington. No local firms submitted a proposal. Most local firms are not offering audit services at this time, as the requirements for offering audit services are increasing.

FISCAL IMPACT: This will be a three-year agreement. The base fee, for 2023, will be \$65,000 and would increase by \$3500 each year. There will be a separate fee if we need a single audit. We will need a single audit in 2023.

ALTERNATIVES:

None practical at this time.

SIGNATURE:

DEPARTMENT HEAD: Heather Lindsley

CITY ADMINISTRATOR APPROVAL: [Signature]



bergankdv

CITY OF COLUMBUS, NEBRASKA TECHNICAL PROPOSAL AUDIT SERVICE

BerganKDV
Contact: Timothy Lens, CPA
16924 Frances Street
Omaha, Nebraska 68130
tim.lens@bergankdv.com

EMPOWERING PEOPLE and CREATING A WOW EXPERIENCE FOR OUR CLIENTS.

TABLE OF CONTENTS

Profile of Firm Proposing:

Letter of Transmittal	2
Who is BerganKDV?	4
Value-Added Services Beyond the Audit	7
Certifications and Independence	8

Qualifications:

Client References	9
Dedicated Service Team	10

Scope of Services and Proposed Project Schedule:

Audit Approach and Timeline	15
-----------------------------------	----

Fees and Compensation:

Fees	19
------------	----

Additional Information:

PlainSight.....	20
Peer Review	22

ANNOUNCEMENT

As of July 1, 2023, BerganKDV has joined forces with Creative Planning, LLC, one of the largest and most highly respected independent wealth management firms in the country. BerganKDV will continue to provide audit and other attest services to clients, while Creative Planning Business Services entities will provide tax advisory and consulting services to clients. We remain committed to serving governments with our renowned industry expertise, all while having greater resources and expanded connections to further achieve our client's unique goals. From tax and audit to payroll and strategic planning, we offer an array of business services to transform organizations with a long, tenured understanding of governments. To learn more about our strategic acquisition, please read the formal press release linked here <https://www.bergankdv.com/news/creative-planning-acquires-bergankdv/>

LETTER OF TRANSMITTAL

Heather Lindsey, Finance Director
City of Columbus
2500 14th Street
Columbus, NE 68602

Dear Ms. Lindsey,

On behalf of BerganKDV, I am pleased to submit this proposal for audit services for the City of Columbus, Nebraska. We appreciate the opportunity to bid these services and your consideration of our firm.

The attached proposal addresses the information you requested, including the unique qualifications of BerganKDV, the depth and breadth of the services we will provide your City our commitment to providing the highest-quality work through a process that is both efficient and effective.

Our services would include, but not be limited to, the following for years ending September 30, 2023, 2024, and 2025.

1. Performing an audit of the City in accordance with auditing standards generally accepted in the United States of America, *Government Auditing Standards*, Federal Single Audit and other federal, state, and local requirements, as applicable.
2. Providing an opinion on the City's basic financial statements and an "in-relation to" report on the supporting schedules.
3. Reviewing the City's financial statements and related note disclosures, and supplemental schedules.
4. Reviewing, documenting, and providing recommendations on improving the City's internal control and financial operations.
5. Providing verbal and written guidance on new and ongoing Governmental Accounting Standards Board (GASB) Statements.
6. Meeting with City finance personnel and administration to review the financial statements and a draft of our letter of recommendations for improving the internal control and financial operations of the City and the municipal agency.
7. Presenting the financial statements and communications letter to the City Council.
8. Providing bound copies of the report to the City and the Nebraska State Auditor, including a searchable pdf of the report, and the communications letter.
9. Being available during the year to provide a wide range of consulting services and answer your questions as they arise.

Our Government Market team is located throughout BerganKDV offices. These individuals are dedicated to this industry and primarily work on our governmental entity clients. We have outlined your upper management team in the "Qualifications" section. In addition to these individuals, we will utilize senior and associate level individuals from our Omaha, Nebraska office. Our team will be both on-site and remote to perform your audit.

We will work with your representatives to schedule specific fieldwork dates to ensure we are meeting your deadlines. The undersigned is a partner and is authorized to make representations for the firm. This proposal is a firm and irrevocable offer for 90 days.

Sincerely,

A handwritten signature in black ink that reads "Tim Lens". The signature is written in a cursive, slightly slanted style.

Tim Lens

Shareholder

tim.lens@bergankdv.com



We have an extensive background in working with clients through a strategic approach in all aspects; we do not just keep pace with the trends; we stay ahead of the curve. We explore new ways to reduce costs and operate more efficiently.

THE BACKSTORY

The history of our firm began in 1945, and since the beginning, BerganKDV has been firmly rooted in community. Today we are a Top 100 Firm, we operate in multiple states in nine different offices, employ over 450 experts, and service clients across the country. As we continue to grow, we acknowledge that we are not in the business to provide one-size-fits-all solutions. Every client is different – from business problems to personal preferences. We invest the time to understand your needs and customize our services and solutions to meet them. Our playbook consists of business advisory, tax, assurance and accounting, workforce management, technology, wealth management and turnaround management services. Sure, we offer a robust and competitive service portfolio and notable processes but what really makes us different? [OUR PEOPLE.....](#)

OUR PEOPLE

Relationships are at the core of everything we do, and our products and services are designed to meet the specific needs of our clients. When working with BerganKDV, clients find that we focus on earning their trust by being actively involved and focused on helping them be successful in all they do.

PERSONALIZED SERVICE

Our philosophy is to provide timely, quality services that exceed the expectations of our clients. Outstanding client service requires a successful team effort within our firm and with our clients. Providing outstanding service involves enthusiastic, dependable, and knowledgeable personnel who are responsible for knowing, understanding, and caring about our clients. Our firm believes that outstanding service is a continual process that is refined and enhanced with each client contact.

ENGAGE® | OUR PROVEN VALUE CREATION PROCESS

We have aligned our team around our core values and are driven in our commitment to help clients and team members achieve their potential. We help clients reach their goals by utilizing our value creation process. Results of this process have led to more robust client relationships – deeper trust, enhanced communication, and minimization of time for all. This process is a key component of our strategy in supporting and helping our clients further their organizations.

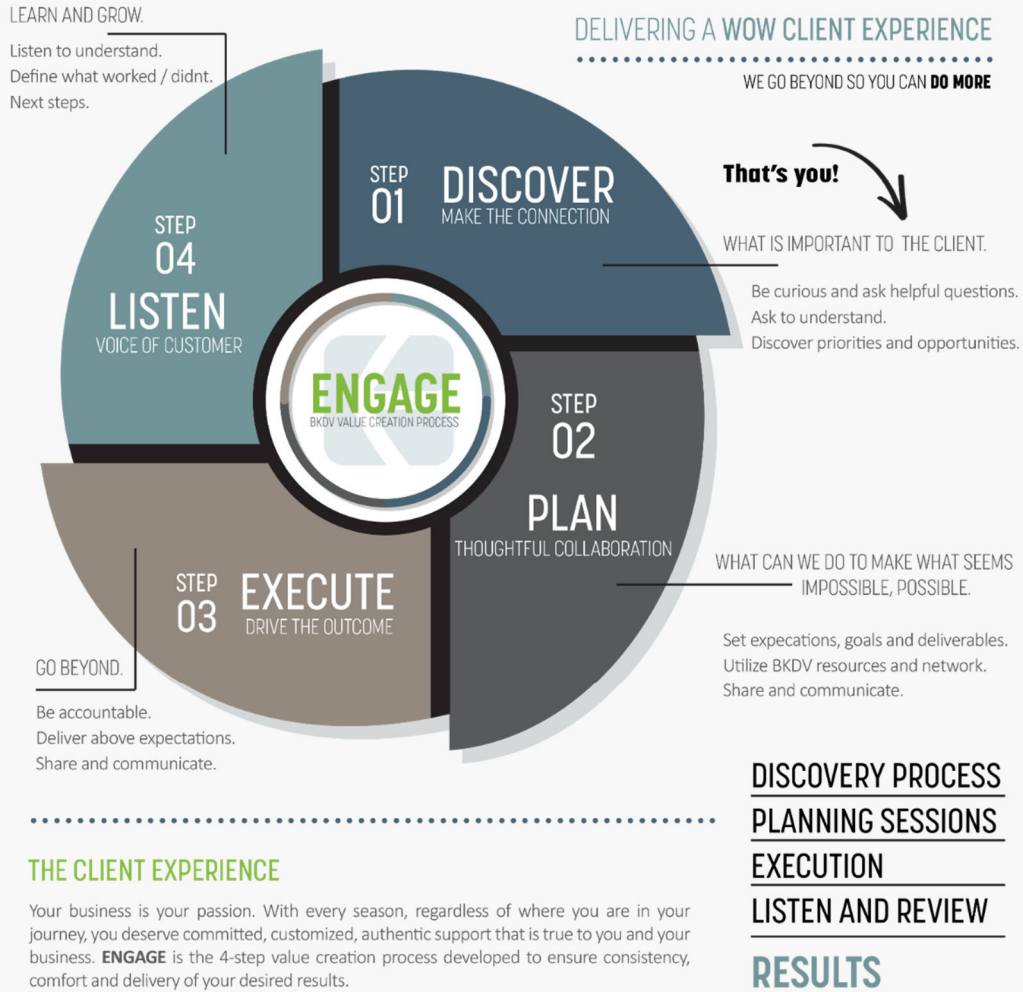

OUR BUSINESS LINES

BerganKDV has a strong bench of resources and expertise available based on needs of the client. This ensures the most effective and efficient results are delivered!



COMMUNITY SUPPORT

At BerganKDV, we believe in giving back. We support the organizations our people and clients are actively involved with. BerganKDV's culture promotes community involvement by providing employees with paid volunteer time off.

VISION AND VALUES

We are powered by people who do business the Midwest way delivering comprehensive business, financial and technology solutions. Our firm consists of highly talented individuals that put relationships before business deals and clients before profits. Our values drive our decisions.



OUR FOCUS AND OUR PROMISE

We continue to align BerganKDV team member core values and sense of purpose with our firm core values and mission. We hire towards our core values and manage performance through real time feedback corresponding to our core values. We have found that this work results in more open conversations at BerganKDV which impacts employee engagement and client care.

VALUE-ADDED SERVICES BEYOND THE AUDIT

Our goal is to be your first call when you experience organizational challenges. We believe this can occur only when a relationship is developed and nurtured through strong communication and a thorough understanding of your mission, programs, and operations. We are unwavering in our commitment to our clients and make it our mission to ask the right questions, listen actively, understand your expectations, and deliver results. You can expect a partnership with professionals who value trust, integrity, and relationships.

Extensive Governmental Auditing and Consulting Experience

With over **50 years of experience** serving the government community, we have a great appreciation for the unique issues and complexities that you face. We currently work with over 150 governmental entities, including cities, charter schools, school districts, colleges and universities, and other governmental entities, providing a wide array of services including accounting, auditing, and consulting services.

We are dedicated to **keeping informed** of significant developments in the government community and the impact of those developments on our clients. We accomplish this through formal training, including annual seminars, workshops and professional sponsored classes on governmental accounting, auditing, and reporting requirements. We are a member of the Governmental Audit Quality Center of the American Institute of Certified Public Accountants. The Center maintains standards for quality control in governmental audits for CPA firms nationwide.

In addition, many employees of our firm are members and have participated as instructors and speakers at seminars. These presentations have included GASB implementations, auditing standards updates, levy process and related accounting, property taxes and general fund budget, budget issues related to the state budget deficit, accounting and finance policies and procedures and fraud.

Peer Review

Our firm is a member of the Private Companies Section of the AICPA Division for CPA Firms. This Division was founded in 1977 by the AICPA to promote CPA excellence and to provide a voluntary, objective means of monitoring adherence to professional standards. Each member firm is required to periodically subject its audit and accounting practice to a comprehensive quality review by specially trained outside CPAs. Our last such review was just performed recently, and we received a clean report on our practices and methods. A copy of our last peer review report is included on page 21.

CERTIFICATIONS AND INDEPENDENCE

We recognize when we audit a governmental entity, we are required to be familiar with certain rules, regulations, and requirements and, as a firm we are required to meet certain requirements. In that regard, we make the following affirmations:

- Our firm meets the independence requirements relating to the City defined by auditing standards generally accepted in the United States of America and *Government Auditing Standards* issued by the Comptroller General of the United States.
- Our firm and all assigned key professional staff are properly licensed to practice in the State of Nebraska.
- Our firm is a member of the American Institute of Certified Public Accountants and the Nebraska Society of Certified Public Accountants.
- Our firm has never had a report rejected or classified as substandard by any state or federal agency, or by the Government Finance Officers Association.
- Our firm has never had and currently does not have any pending disciplinary actions or investigations for alleged improper, fraudulent, disreputable, or unfair activities against our firm with state regulatory bodies or professional organizations.
- We accept the professional obligation concerning the American Institute of Certified Public Accountants Interpretation 501-3 “Failure to Follow Standards and/or Procedures or Other Requirements in Governmental Audits.”
- Our professional personnel have received adequate continuing education to follow *Government Auditing Standards* and have received adequate continuing professional education over the past two years.
- Our firm is an equal opportunity employer and does not discriminate in employment of persons upon the basis of race, color, creed, national origin, sex, age, or physical handicap, and have an affirmative action plan in place.
- We do not expect any potential audit problems and are not aware of any conflicts of interest about any work performed by the firm for the City.
- We acknowledge and have adequate personnel to comply with the audit schedule provided in the request for proposals.

CLIENT REFERENCES AND EXPERIENCE

A few of our Nebraska governmental clients serviced are listed below and we encourage you to contact them.

Sarpy County, Nebraska
 Bill Conley, CFO
 402.539.5958

City of La Vista, Nebraska
 Meg Harris, Finance Director
 402.593.6425

City of Gretna, Nebraska
 Paula Dennison, City Administrator
 402.332.3336

Over the past year, BerganKDV has served as independent auditor or consultant for many Cities and Townships as listed below. Audit clients awarded the GFOA Certificate of Excellence in Financial Reporting are identified with an asterisk.

Iowa Cities

Population (0-2,000)

Epworth, IA
 North English, IA
 Goodell, IA

Population (2,001-5,000)

Cascade, IA
 Evansdale, IA
 Dyersville, IA

Population (5,001-15,000)

Independence, IA
 Knoxville, IA

Population (15,001<)

Coralville, IA
 North Liberty, IA
 Sioux City, IA*

Minnesota and Nebraska Cities

Population (0-2,000)

Bock, MN
 Clear Lake, MN
 Clearwater, MN
 Dundas, MN
 Eden Valley, MN
 Hilltop, MN
 Richmond, MN
 Silver Bay, MN
 Watkins, MN
 Waverly, MN

Population (2,001-5,000)

Ashland, NE
 Bennington, NE
 Cold Spring, MN
 Deephaven, MN*
 Elko-New Market, MN
 Greenfield, MN
 Hanover, MN
 Le Seuer, MN
 Mora, MN
 Nowthen, MN
 Rockville, MN
 Two Harbors, MN

Population (5,001-15,000)

Baxter, MN*
 Big Lake, MN
 Corcoran, MN
 Dayton, MN
 Detroit Lakes, MN*
 Falcon Heights, MN*
 Fergus Falls, MN*
 Gretna, NE
 Marshall, MN
 Mendota Heights, MN
 Oak Grove, MN
 Osseo, MN
 Otsego, MN*
 Sauk Rapids, MN
 St. Joseph, MN
 Wyoming, MN

Population (15,001<)

Albert Lea, MN*
 Brooklyn Park, MN*
 Cottage Grove, MN*
 Crystal, MN*
 Eden Prairie, MN*
 Faribault, MN*
 Forest Lake, MN*
 Grand Island, NE
 Ham Lake, MN*
 Hastings, NE*
 La Vista, MN*
 Maplewood, MN*
 Minnetonka, MN*
 New Brighton, MN*
 Richfield, MN*
 St. Cloud, MN*
 Sartell, MN
 Woodbury, MN*

DEDICATED SERVICE TEAM

BerganKDV has a personalized team of professionals to meet your unique needs. Your BerganKDV team has extensive experience working with governmental organizations. This translates into a greater ability to understand your unique organization.

LEADERSHIP TEAM

First, all governmental clients will interact with a member of the Government Market's leadership team at least annually. There is no charge to our clients for these meetings. These individuals are instrumental in ensuring that our clients are receiving "WOW" service and having all their needs met.



MICHAEL E. DUSCHER, GOVERNMENT CONSULTING LEADER

Minneapolis, Minnesota office

Role and Experience: Mike serves clients in the government sector. He is responsible for growing the client base in the government market by building relationships with potential clients and working with them to help solve pain points they are experiencing in their business operations.

Mike received his bachelor's degree in organizational communication and sociology. He is involved with Northern Voices, a nationally recognized school for deaf and hearing of children and Crescent Cover Respite & Hospice Home for Kids.

On the next couple of pages, we have included the resume for the Shareholder and Director that would oversee your engagement. In addition to the individual resumes listed, we will utilize additional associates on your audit engagement from our GASB team.

DEDICATED SERVICE TEAM (CONTINUED)



TIM LENS, CPA, ENGAGEMENT PARTNER

Omaha, Nebraska office

Education: Bachelor of Science in Business Administration from Midland University

Experience, Professional and Civic Activities:

- American Institute of Certified Public Accountants
- Nebraska Society of Certified Public Accountants, Vice Chair of the State & Local Governmental Accounting & Auditing Committee
- Association of Government Accountants (AGA)
- Omaha Running Club, Board of Directors

Tim specializes in:

- Planning, performing, and supervising consolidated financial statement audits
- Preparing and reviewing consolidated financial statements
- Analyzing internal controls, policies and consulting on accounting policies and procedures manuals

DEDICATED SERVICE TEAM (CONTINUED)



NANCY SCHULZETENBERG, CPA, CONCURRING PARTNER

Education: Bachelor of Science in Accounting from Mankato State University, graduated Summa Cum Laude

Experience, Professional and Civic Activities:

- Thirty years of experience in auditing governmental and nonprofit entities
- Member of the Quality Control Committee for our firm
- Appointed by the Commissioner of Education to serve as a member of the Minnesota Department of Education’s Advisory Committee on Financial Management, Accounting and Reporting
- Member of the Special Review Committee of the Government Finance Officers Association whose purpose is to review Annual Comprehensive Financial Reports to determine eligibility for the Certificate of Achievement for Excellence in Financial Reporting
- Presenter at the Minnesota Association of School Business Officials Annual Conference, the Central Minnesota Educational Research & Development Council’s Annual Conference, the MN Government Finance Officer’s Association’s Annual Conference, and BergankDV sponsored seminars
- Instructor at the Minnesota Association of School Business Officials Institute and the Minnesota Association of School Business Officials Certification Program
- Member of Minnesota Society of Certified Public Accountants, American Institute of Certified Public Accountants, Minnesota Association of School Business Officials, and Government Finance Officers Association

DEDICATED SERVICE TEAM (CONTINUED)



BRIAN DENIO, CPA, AUDIT MANAGER

Education: Bachelor of Science in Business Administration from University of Arizona, Eller College of Management, graduated Summa Cum Laude

Bachelor of Arts in education from University of Nebraska-Kearney, graduated Magna Cum Laude, with honors

Experience, Professional and Civic Activities:

- Thirteen years of experience in auditing a variety of governmental, not-for-profit, and for profit entities as well as employee benefit plans
- Responsible for the planning, fieldwork and reports for numerous audits of cities, school districts and other government entities
- Attends continuing education, workshops and conferences on city and school district accounting and reporting requirements on an annual basis that qualifies as “yellow book” continuing professional education
- Attends workshops on governmental and single audit accounting, auditing and reporting on an annual basis
- Financial statement and communication letter preparation
- Extensive use of computer and software applications to assist in the preparation and performance of the audit process
- Certified Public Accountant, licensed to practice in the State of Nebraska
- Nebraska Society of Certified Public Accountants
- American Institute of Certified Public Accountants

DEDICATED SERVICE TEAM (CONTINUED)

Office Performing Audit

Our Government Market team is located throughout BergankDV offices. These individuals work only on our governmental entity clients. We have outlined your upper management team in the "Qualifications" section. Our team consists of 3 shareholders, 4 audit directors/managers, 1 director of consulting, 4 senior/supervisor and 8 associate level members, all that focus on governmental entities. In addition, we have another shareholder, 2 directors, 2 seniors and 5 associate level members that all have experience working on governmental audits. In addition to individual resumes listed on pages 10-13, we will utilize 1 senior and 1-2 associate level members on your audit engagement from our Omaha, Nebraska office.

Commitment to Staff Continuity and Training

To keep continuity and efficiencies high, we believe that consistent team members are advantageous for both our firm and your organization. We pride ourselves on maintaining the right balance of continuity on each of our engagements to ensure a "fresh" look at the annual audit process. Rotation of senior level staff only occurs after the merits of such rotation have been discussed and approved by your organization.

Independence

Our firm has no conflict of interest regarding any other work performed by our firm for your organization. Our firm meets the independence requirements relating to your organization as defined by auditing standards generally accepted in the United States of America. We annually review independence related to all our client relationships as part of our internal control compliance process.



AUDIT APPROACH AND TIMELINE

OUR GOAL FOR YOU IS TO CREATE VALUE AND TO MINIMIZE SURPRISES. We do this through a specific, well-planned audit. What makes BerganKDV unique from other firms is that we continually improve our audit process beyond what is expected by our profession. A few of the BerganKDV advantages:

- **Collaborative Audit Process.** We see the audit process as a joint effort with you and BerganKDV. We want to work together to make it as painless as possible.
- **A comprehensive view of the City's financial health.** Through our extensive government experiences, we understand a City's health is not only about the finances. The vision, mission and programming provide the blueprint for the City's direction. We review this information in relation to the financial statements and provide our observations based on a comprehensive view of the City's health.
- **Technology resource on internal controls.** Technology experts from the BerganKDV Technology Group can assist in evaluating your technology controls. Their expert advice has proven to be a valuable resource as they answer technical questions and offer specific recommendations.
- **Review of the work papers during fieldwork.** We complete most of our work in the field and provide a comprehensive exit conference. The exit conference includes a review of the draft financial statement numbers, any internal control, compliance, and state statute findings.
- **Supervisors, managers and partners on-site.** The involvement of our supervisors, managers and partners in the field is essential to being a trusted partner and delivering an exceptional client experience. We believe it is important to be on-site and available to answer questions. This also allows our managers and partners to review documentation throughout the process.
- **Meeting communications.** Our presentations are designed to capture information that is useful and meaningful. Our presentations are focused on audit results, trends, and other information relevant to your City and related entities, not details of the financial statement amounts.

Beyond Expectations

BerganKDV takes a four-phased audit approach that gets results by:

- Leveraging what is working well.
- Focusing on pre audit planning, collaboration, and communication.
- Staying accountable to a schedule.
- Meeting with you and your team to ensure every detail has been finalized and the audit is complete.
- Exchanging information regarding our performance, opportunities to enhance experiences and future strategic opportunities.

AUDIT APPROACH AND TIMELINE (CONTINUED)

Our audits are designed to focus our energy and our audit tests on the areas of your operations that contain the most risk. This equates to a better product for the City.

PHASE ONE – INITIAL PLANNING AND PROGRAM DEVELOPMENT (SEPTEMBER)

Our main objective is to get to know the City as a resident or employee would. We want to understand not only your finances, but also your operational goals and objectives. What makes your City unique? How can that knowledge help us perform the best audit possible? When those questions are answered, we know we achieved our goal for Phase One.

During this phase, we gather the information we need to create an effective audit program and make preliminary judgments of materiality. Highlights include:

- Reviewing your internal control documents and interviewing your key employees and representatives to gain operational information.
- Discussing your goals, objectives, and the current challenges facing your operations; those are then shared across your BerganKDV team and incorporated into our audit plan.
- Obtaining population sizes ranging from 25-60 for certain transactions-based finance systems and selecting which transactions we will test for internal control and compliance testing. Selections will be based on our data analysis results, analyzing transactions on a risk-based level.
- Obtaining your current financial reports and budgets and perform overall analytical review procedures.
- Obtaining applicable City organizational charts, policies, bond documents, leases, and other legal contracts.
- Reviewing with your staff our audit documentation requests. **We audit and request information that is used internally by your staff to manage operations, we do not require specific templates to be used.**

We will work with the management team to determine the preferred means of communication, whether phone or email. In addition, we utilize Suralink, a workflow management software that improves efficiency by streamlining our audit request process. The simple interface includes team assignments and deadlines, so there are no misunderstandings on expectations.

Our audit process incorporates automated audit tools (Knowledge Coach) and work papers to provide our clients with timely information and effective and efficient audits. In addition, we use CCH's TeamMate Analytics, an Excel add-on used to extract and analyze data quickly and efficiently. We also subscribe to various benchmarking and data analysis providers.

Your Expected Role: *Provide BerganKDV with policies, internal control documents and a preliminary trial balance; provide contact information for all board members and staff so we may set up appointments/interviews with selected representatives; begin to gather documentation for fieldwork.*

AUDIT APPROACH AND TIMELINE (CONTINUED)

PHASE TWO – AUDIT PROGRAM EXECUTION (PRELIMINARY FIELDWORK (DECEMBER) (FINAL FIELDWORK FEBRUARY)

Project execution is performing the procedures outlined in your audit plan as developed in Phase One. Our audit procedures will include examining, on a test basis, evidence supporting the amounts and disclosures in the financial statements. We will discuss potential ideas and best practices with your personnel relating to our recommendations for improving internal control, procedures and compliance with laws and regulations. Any issues identified, proposed audit adjustments, or other recommendations will be discussed with management throughout the execution of our audit procedures. We perform test work with as little disruption as possible to City staff's regular duties.

Highlights of this phase include:

- Auditing year-end account balances, testing internal control, assessing compliance to determine if your systems and controls are functioning as designed.
- Using sampling techniques to test areas including transactions, internal controls and legal compliance using the scope mandated by the Office of the State Auditor. Sample sizes range from 25-60 based on our risk assessment.
- Using IDEAS data mining software, we look for trends and anomalies in your payroll, vendor payment, and cash receipts process.

Your Expected Role: Be available to answer questions during scheduled audit fieldwork, provide audit workpapers or reconciliations with documentation that is reasonable and reviewed during Phase One.

PHASE THREE – POST-AUDIT CRITIQUE AND EXIT CONFERENCE (FEBRUARY/MARCH)

This phase of the audit includes reviewing all the components of the financial statements and prepare the communications letter and relevant financial trend data for the Council presentation. Finally, opinions on the financial statements, Government Auditing Standards and Single Audit, if required, will be prepared.

We will then present this information to management allowing you time to review the financial statement reporting package including the draft financial statements and any internal control findings or recommendations that arise during the audit. This phase allows you time to assess, discuss and develop a corrective action plan, if needed.

Your Expected Role: Review preliminary financial statements and reports to provide BergankDV with input and feedback.

AUDIT APPROACH AND TIMELINE (CONTINUED)

PHASE FOUR – PRESENTATION OF AUDIT REPORT

The final phase of the process is the presentation of the reports to the City Council. The presentation provides the governing body with information about the year's financial activity compared to past trends and expected results. We also provide other relevant and interesting observations relating to your financial statistics that will help provide the governing board with a deeper understanding of your operations. We understand all organizations have individual needs and we look forward to getting your feedback on graphs and statistics.

Professional standards require that we provide you with information regarding the auditor's responsibility under generally accepted auditing standards, significant accounting policies, accounting estimates and management judgments, significant audit adjustments, other information in documents containing audited financial statements, disagreements with management, consultation with other auditors, major issues discussed with management prior to retention as auditors and difficulties encountered in performing the audit. We will provide this information in written form via the communications letter and will discuss with administration during the review of the preliminary audit report.

***Your Expected Role:** Provide BerganKDV with information and feedback for presentation preferences.*

FEES

Our fees for the Technical Proposal are based on the amount of time and the level of experience of the individuals who perform the services. In addition, we assume that the City's accounting personnel will provide the appropriate workpapers, documents, schedules, and clerical assistance, we will not encounter any significant or unusual circumstances which will affect the scope of our engagement, and no significant changes to the Organization's operations will occur. However, if situations arise which affect the scope of the engagement or we are required to make audit adjusting entries or information is not provided within on agreed upon schedule, we will discuss them with you prior to incurring the additional cost. **At no time will we bill the City for extra time or charges unless we have verbal communication regarding the issues, your options and an agreement for additional fees.**

Following is a description of the services we will provide under this agreement for the years ended September 30, 2023, 2024, and 2025:

- Performing an audit of the City, in accordance with auditing standards generally accepted in the United States of America and *Government Auditing Standards*; and Uniform Guidance, when applicable;
- Providing an opinion on the basic financial statements and an “in-relation to” report on the supplementary information;
- Providing separate reports required under *Government Auditing Standards*, Federal Awards as required under Uniform Guidance, as applicable;
- Drafting the financial statements;
- Presenting the financial statements and communication letter to the City Council; and

The fee for the mentioned services will be:

September 30, 2023	\$ 65,000, with additional \$5,000 for single audit, if applicable Additional \$5,000 fee if only one year engagement
September 30, 2024	\$ 68,500, with additional \$5,200 for single audit, if applicable
September 30, 2025	\$72,000, with additional \$5,400 for single audit, if applicable

The above single audit fees are for testing one federal program. If more than one federal program is required to be tested, additional fees will be negotiated.

Billing and Collection Expectations

Our fees are due as services progress and are generally billed throughout each phase of the audit. These invoices are payable on presentation. Invoices are delinquent if not paid within 30 days.

Off-season Communication

We encourage questions throughout the year and ask our clients to submit to us their monthly financial statements and board of director minutes, so we can stay abreast of their operations, and identify/resolve any issues prior to year-end. We will not invoice additional amounts unless substantial research or work is required, in which case, we will discuss the scope of any additional work and proceed only after we have reached a mutually agreeable fee arrangement.

Out of Scope Professional Services

We do not surprise bill. If during our engagement you request additional services which require more than a minimum amount of time, we will provide an engagement letter with the fees and services specified, only after we have verbal communication and agreement. Additional special projects and consulting requested during the year will be billed at an hourly rate commensurate with the level of experience required.



FRAUD AT ANY LEVEL AT YOUR COMPANY IS OFTEN HAPPENING IN CLEAR VIEW. DO YOU SEE IT?

With BerganKDV's PlainSight, you can empower your employees to speak up when they witness fraudulent activity through an easily accessible and completely anonymous hotline system. Based on the tip criteria, our certified team of fraud professionals is available to investigate and report back with next steps if fraudulent evidence is discovered.

One year subscription complimentary for first year audit engagements

A TIP COULD BE ALL IT TAKES

You can rest assured as a business leader that your employees are equipped with a powerful and safe tool to protect your company against those who wish to harm it.

OUR PROMISE TO YOU

We will work directly with you to establish an implementation and use strategy that fits your needs and coordinate with you when tips become viable signs of potential fraudulent activity. Safety and anonymity are our main priority for your business. Our goal is to highly encourage hotline usage and promote the idea that no tip is too small to make a difference.

It is estimated that organizations lose 5% of revenue each year due to fraud with average losses being around \$1.5 million. **Don't foot the bill to fraudsters.**

MORE THAN A PHONE LINE

WHAT OTHER SERVICES ARE INCLUDED WHEN YOU UTILIZE PLAINSIGHT FOR YOUR FRAUD DETECTING NEEDS?

- Easy to use web submission tool
- Communication packages to educate and inform your employees
- On-demand employee training for how to use and signs of fraud
- Admin level access to review items and communicate with our Forensic team

Let our team of experts grant you peace of mind and educate your employees to make the call today that may save you tomorrow.



FIND YOUR PEACE OF MIND

bergankdv.com | connect@bergankdv.com | #starthere

bergankdv

PEER REVIEW



Report on the Firm's System of Quality Control

March 12, 2021

To the Partners of BerganKDV, LLC
and the Peer Review Committee of the Minnesota Society of CPAs.

We have reviewed the system of quality control for the accounting and auditing practice of BerganKDV, LLC (the firm) in effect for the year ended March 31, 2020. Our peer review was conducted in accordance with the Standards for Performing and Reporting on Peer Reviews established by the Peer Review Board of the American Institute of Certified Public Accountants (Standards).

A summary of the nature, objectives, scope, limitation of, and the procedures performed in a System Review as described in the Standards may be found at www.aicpa.org/prsummary. The summary also includes an explanation of how engagements identified as not performed or reported in conformity with applicable professional standards, if any, are evaluated by a peer reviewer to determine a peer review rating.

Firm's Responsibility

The firm is responsible for designing a system of quality control and complying with it to provide the firm with reasonable assurance of performing and reporting in conformity with applicable professional standards in all material respects. The firm is also responsible for evaluating actions to promptly remediate engagements deemed as not performed or reported in conformity with professional standards, when appropriate, and for remediating weaknesses in its system of quality control, if any.

Peer Reviewer's Responsibility

Our responsibility is to express an opinion on the design of the system of quality control and the firm's compliance therewith based on our review.

Required Selections and Considerations

Engagements selected for review included an engagement performed under *Government Auditing Standards*, including compliance under the Single Audit Act, and audits of employee benefit plans.

As a part of our peer review, we considered reviews by regulatory entities as communicated by the firm, if applicable, in determining the nature and extent of our procedures.

PEER REVIEW (CONTINUED)

The Partners of BergankDV, LLC
and the Peer Review Committee of the Minnesota Society of CPAs
Page Two

Opinion

In our opinion, the system of quality control for the accounting and auditing practice of BergankDV, LLC in effect for the year ended March 31, 2020, has been suitably designed and complied with to provide the firm with reasonable assurance of performing and reporting in conformity with applicable professional standards in all material respects. Firms can receive a rating of *pass*, *pass with deficiency (ies)*, or *fail*. BergankDV, LLC has received a peer review rating of *pass*.

Certified Public Accountants

Little Rock, Arkansas

THANK YOU.

BERGANKDV.COM | 402.330.7008 | INFO@BERGANKDV.COM



15. **ORDINANCES ON FIRST READING - None**
16. **ORDINANCES ON SECOND READING - None**
17. **ORDINANCES ON THIRD READING - None**
18. **CONSIDERATION OF PAYROLL AND BILLS ON FILE - Included in Consent Agenda.**
19. **UNFINISHED BUSINESS - None**
20. **ADJOURNMENT**