

City Council Regular Meeting
Monday, June 5, 2023 7:00 PM
Council Chambers
2500 14 Street
Columbus, NE 68601

The Mayor and City Council reserve the right to go into closed session as per Section 84-1410 of the Nebraska Revised Statutes. A current agenda is on file at City Hall, 2500 14 Street, Columbus, Nebraska. For more information, call 402-562-4224 or visit our website at www.columbusne.us.

{{Name: Agenda Item Name}}

**1. STATEMENT OF COMPLIANCE WITH OPEN MEETINGS ACT AND ROLL
CALL**

NEBRASKA OPEN MEETINGS ACT

84-1407. Act, how cited.

Sections 84-1407 to 84-1414 shall be known and may be cited as the Open Meetings Act.

Source: Laws 2004, LB 821, § 34.

84-1408. Declaration of intent; meetings open to public.

It is hereby declared to be the policy of this state that the formation of public policy is public business and may not be conducted in secret.

Every meeting of a public body shall be open to the public in order that citizens may exercise their democratic privilege of attending and speaking at meetings of public bodies, except as otherwise provided by the Constitution of Nebraska, federal statutes, and the Open Meetings Act.

Source: Laws 1975, LB 325, § 1; Laws 1996, LB 900, § 1071; Laws 2004, LB 821, § 35.

Annotations

- Nebraska's public meetings laws do not apply to school board deliberations pertaining solely to disputed adjudicative facts. *McQuinn v. Douglas Cty. Sch. Dist. No. 66*, 259 Neb. 720, 612 N.W.2d 198 (2000).
- The primary purpose of the public meetings law is to ensure that public policy is formulated at open meetings. *Marks v. Judicial Nominating Comm.*, 236 Neb. 429, 461 N.W.2d 551 (1990).
- The public meetings law is broadly interpreted and liberally construed to obtain the objective of openness in favor of the public, and provisions permitting closed sessions must be narrowly and strictly construed. *Grein v. Board of Education of Fremont*, 216 Neb. 158, 343 N.W.2d 718 (1984).
- Although a committee was a subcommittee of a natural resources district board, it was not subject to the Open Meetings Act because there was never a quorum of board members in attendance and the committee did not hold hearings, make policy, or take formal action on behalf of the board. *Koch v. Lower Loup NRD*, 27 Neb. App. 301, 931 N.W.2d 160 (2019).
- A county board of equalization is a public body whose meetings shall be open to the public. *Wolf v. Grubbs*, 17 Neb. App. 292, 759 N.W.2d 499 (2009).

84-1409. Terms, defined.

For purposes of the Open Meetings Act, unless the context otherwise requires:

(1)(a) Public body means (i) governing bodies of all political subdivisions of the State of Nebraska, (ii) governing bodies of all agencies, created by the Constitution of Nebraska, statute, or otherwise pursuant to law, of the executive department of the State of Nebraska, (iii) all independent boards, commissions, bureaus, committees, councils, subunits, or any other bodies created by the Constitution of Nebraska, statute, or otherwise pursuant to law, (iv) all study or advisory committees of the executive department of the State of Nebraska whether having continuing existence or appointed as special committees with limited existence, (v) advisory committees of the bodies referred to in subdivisions (i), (ii), and (iii) of this subdivision, and (vi) instrumentalities exercising essentially public functions; and

(b) Public body does not include (i) subcommittees of such bodies unless a quorum of the public body attends a subcommittee meeting or unless such subcommittees are holding hearings, making policy, or taking formal action on behalf of their parent body, except that all meetings of any subcommittee established under section 81-15,175 are subject to the Open Meetings Act, (ii) entities conducting judicial proceedings unless a court or other judicial body is exercising rulemaking authority, deliberating, or deciding upon the issuance of administrative orders, and (iii) the Judicial Resources Commission or subcommittees or subgroups of the commission;

(2) Meeting means all regular, special, or called meetings, formal or informal, of any public body for the purposes of briefing, discussion of public business, formation of tentative policy, or the taking of any action of the public body; and

(3) Virtual conferencing means conducting or participating in a meeting electronically or telephonically with interaction among the participants subject to subsection (2) of section 84-1412.

Source: Laws 1975, LB 325, § 2; Laws 1983, LB 43, § 1; Laws 1989, LB 429, § 42; Laws 1989, LB 311, § 14; Laws 1992, LB 1019, § 124; Laws 1993, LB 635, § 1; Laws 1996, LB 1044, § 978; Laws 1997, LB 798, § 37; Laws 2004, LB 821, § 36; Laws 2007, LB296, § 810; Laws 2011, LB366, § 2; Laws 2021, LB83, § 11; Laws 2022, LB922, § 12.

Operative Date: July 21, 2022

Annotations

- A township is a political subdivision, and as such, a township board is subject to the provisions of the public meetings laws. *Steenblock v. Elkhorn Township Bd.*, 245 Neb. 722, 515 N.W.2d 128 (1994).
- A county agricultural society is a public body to which the provisions of the Nebraska public meetings law are applicable. *Nixon v. Madison Co. Ag. Soc'y*, 217 Neb. 37, 348 N.W.2d 119 (1984).
- Failure by a public governing body, as defined under section 84-1409, R.R.S.1943, to take and record a roll call vote on an action, as required by section 84-1413(2), R.S.Supp.,1980, grants any citizen the right to sue for the purpose of

having the action declared void. In this case such failure could not be later corrected by a nunc pro tunc order because there was no showing that a roll call vote on the disputed action was actually taken, and even if it was the record showed it was not recorded until over a year later. Sections 23-1301, R.R.S.1943, and 23-1302, R.R.S.1943, make it the duty of the county clerk to record proceedings of the board of county commissioners. *State ex rel. Schuler v. Dunbar*, 208 Neb. 69, 302 N.W.2d 674 (1981).

- Although a committee was a subcommittee of a natural resources district board, it was not subject to the Open Meetings Act because there was never a quorum of board members in attendance and the committee did not hold hearings, make policy, or take formal action on behalf of the board. *Koch v. Lower Loup NRD*, 27 Neb. App. 301, 931 N.W.2d 160 (2019).
- Although the Open Meetings Act does not define "subcommittee," a subcommittee is generally defined as a group within a committee to which the committee may refer business. *Koch v. Lower Loup NRD*, 27 Neb. App. 301, 931 N.W.2d 160 (2019).
- The Open Meetings Act does not require policymakers to remain ignorant of the issues they must decide until the moment the public is invited to comment on a proposed policy. By excluding nonquorum subgroups from the definition of a public body, the Legislature has balanced the public's need to be heard on matters of public policy with a practical accommodation for a public body's need for information to conduct business. *Koch v. Lower Loup NRD*, 27 Neb. App. 301, 931 N.W.2d 160 (2019).
- As an administrative agency of the county, a county board of equalization is a public body. *Wolf v. Grubbs*, 17 Neb. App. 292, 759 N.W.2d 499 (2009).
- The electors of a township at their annual meeting are a public body under the Open Meetings Act. *State ex rel. Newman v. Columbus Township Bd.*, 15 Neb. App. 656, 735 N.W.2d 399 (2007).
- The meeting at issue in this case was a "meeting" within the parameters of subsection (2) of this section because it involved the discussion of public business, the formation of tentative policy, or the taking of any action of the public power district. *Hansmeyer v. Nebraska Pub. Power Dist.*, 6 Neb. App. 889, 578 N.W.2d 476 (1998).
- Informational sessions in which the governmental body hears reports are briefings. *Johnson v. Nebraska Environmental Control Council*, 2 Neb. App. 263, 509 N.W.2d 21 (1993).

84-1410. Closed session; when; purpose; reasons listed; procedure; right to challenge; prohibited acts; chance meetings, conventions, or workshops.

(1) Any public body may hold a closed session by the affirmative vote of a majority of its voting members if a closed session is clearly necessary for the protection of the public interest or for the prevention of needless injury to the reputation of an individual and if such individual has not requested a public meeting. The subject matter and the reason necessitating the closed session shall be identified in the motion to close. Closed sessions may be held for, but shall not be limited to, such reasons as:

(a) Strategy sessions with respect to collective bargaining, real estate purchases, pending litigation, or litigation which is imminent as evidenced by communication of a claim or threat of litigation to or by the public body;

(b) Discussion regarding deployment of security personnel or devices;

(c) Investigative proceedings regarding allegations of criminal misconduct;

(d) Evaluation of the job performance of a person when necessary to prevent needless injury to the reputation of a person and if such person has not requested a public meeting;

(e) For the Community Trust created under section 81-1801.02, discussion regarding the amounts to be paid to individuals who have suffered from a tragedy of violence or natural disaster; or

(f) For public hospitals, governing board peer review activities, professional review activities, review and discussion of medical staff investigations or disciplinary actions, and any strategy session concerning transactional negotiations with any referral source that is required by federal law to be conducted at arms length.

Nothing in this section shall permit a closed meeting for discussion of the appointment or election of a new member to any public body.

(2) The vote to hold a closed session shall be taken in open session. The entire motion, the vote of each member on the question of holding a closed session, and the time when the closed session commenced and concluded shall be recorded in the minutes. If the motion to close passes, then the presiding officer immediately prior to the closed session shall restate on the record the limitation of the subject matter of the closed session. The public body holding such a closed session shall restrict its consideration of matters during the closed portions to only those purposes set forth in the motion to close as the reason for the closed session. The meeting shall be reconvened in open session before any formal action may be taken. For purposes of this section, formal action shall mean a collective decision or a collective commitment or promise to make a decision on any question, motion, proposal, resolution, order, or ordinance or formation of a position or policy but shall not include negotiating guidance given by members of the public body to legal counsel or other negotiators in closed sessions authorized under subdivision (1)(a) of this section.

(3) Any member of any public body shall have the right to challenge the continuation of a closed session if the member determines that the session has exceeded the reason stated in the original motion to hold a closed session or if the member contends that the closed session is neither clearly necessary for (a) the protection of the public interest or (b) the prevention of needless injury to the reputation of an individual. Such challenge shall be overruled only by a majority vote of the members of the public body. Such challenge and its disposition shall be recorded in the minutes.

(4) Nothing in this section shall be construed to require that any meeting be closed to the public. No person or public body shall fail to invite a portion of its members to a meeting, and no public body shall designate itself a subcommittee of the whole body for the purpose of circumventing the Open Meetings Act. No closed session, informal meeting, chance meeting, social gathering, email, fax, or other electronic communication shall be used for the purpose of circumventing the requirements of the act.

(5) The act does not apply to chance meetings or to attendance at or travel to conventions or workshops of members of a public body at which there is no meeting of the body then intentionally convened, if there is no vote or other action taken regarding any matter over which the public body has supervision, control, jurisdiction, or advisory power.

Source: Laws 1975, LB 325, § 3; Laws 1983, LB 43, § 2; Laws 1985, LB 117, § 1; Laws 1992, LB 1019, § 125; Laws 1994, LB 621, § 1; Laws 1996, LB 900, § 1072; Laws 2004, LB 821, § 37; Laws 2004, LB 1179, § 1; Laws 2006, LB 898, § 1; Laws 2011, LB390, § 29; Laws 2012, LB995, § 17.

Annotations

- There is no absolute discovery privilege for communications that occur during a closed session. *State ex rel. Upper Republican NRD v. District Judges*, 273 Neb. 148, 728 N.W.2d 275 (2007).
- If a person present at a meeting observes a public meetings law violation in the form of an improper closed session and fails to object, that person waives his or her right to object at a later date. *Wasikowski v. Nebraska Quality Jobs Bd.*, 264 Neb. 403, 648 N.W.2d 756 (2002).
- The public interest mentioned in this section is that shared by citizens in general and by the community at large concerning pecuniary or legal rights and liabilities. *Grein v. Board of Education*, 216 Neb. 158, 343 N.W.2d 718 (1984).
- Hearing in closed executive session was contrary to this section since there was no showing of necessity or reason under subdivision (1)(a), (b), or (c), but did not result in reversal of board decision. *Simonds v. Board of Examiners*, 213 Neb. 259, 329 N.W.2d 92 (1983).
- Negotiations for the purchase of land need not be conducted at an open meeting but the deliberations of a city council as to whether an offer to purchase real estate

should be made should take place in an open meeting. *Pokorny v. City of Schuyler*, 202 Neb. 334, 275 N.W.2d 281 (1979).

- Public meeting law was not violated where the Board of Regents of the University of Nebraska voted to hold a closed session to consider the university president's resignation, and also discussed the appointment of an interim president during such session. *Meyer v. Board of Regents*, 1 Neb. App. 893, 510 N.W.2d 450 (1993).

84-1411. Meetings of public body; notice; method; contents; when available; right to modify; duties concerning notice; virtual conferencing authorized; requirements; emergency meeting without notice; appearance before public body.

(1)(a) Each public body shall give reasonable advance publicized notice of the time and place of each meeting as provided in this subsection. Such notice shall be transmitted to all members of the public body and to the public.

(b)(i) Except as provided in subdivision (1)(b)(ii) of this section, in the case of a public body described in subdivision (1)(a)(i) of section 84-1409 or such body's advisory committee, such notice shall be published in a newspaper of general circulation within the public body's jurisdiction and, if available, on such newspaper's website.

(ii) In the case of the governing body of a city of the second class or village or such body's advisory committee, such notice shall be published by:

(A) Publication in a newspaper of general circulation within the public body's jurisdiction and, if available, on such newspaper's website; or

(B) Posting written notice in three conspicuous public places in such city or village. Such notice shall be posted in the same three places for each meeting.

(iii) In the case of a public body not described in subdivision (1)(b)(i) or (ii) of this section, such notice shall be given by a method designated by the public body.

(c) In addition to a method of notice required by subdivision (1)(b)(i) or (ii) of this section, such notice may also be provided by any other appropriate method designated by such public body or such advisory committee.

(d) Each public body shall record the methods and dates of such notice in its minutes.

(e) Such notice shall contain an agenda of subjects known at the time of the publicized notice or a statement that the agenda, which shall be kept continually current, shall be readily available for public inspection at the principal office of the public body during normal business hours. Agenda items shall be sufficiently descriptive to give the public reasonable notice of the matters to be considered at the meeting. Except for items of an emergency nature, the agenda shall not be altered later than (i) twenty-four hours before the scheduled commencement of the meeting or

(ii) forty-eight hours before the scheduled commencement of a meeting of a city council or village board scheduled outside the corporate limits of the municipality. The public body shall have the right to modify the agenda to include items of an emergency nature only at such public meeting.

(2)(a) The following entities may hold a meeting by means of virtual conferencing if the requirements of subdivision (2)(b) of this section are met:

(i) A state agency, state board, state commission, state council, or state committee, or an advisory committee of any such state entity;

(ii) An organization, including the governing body, created under the Interlocal Cooperation Act, the Joint Public Agency Act, or the Municipal Cooperative Financing Act;

(iii) The governing body of a public power district having a chartered territory of more than one county in this state;

(iv) The governing body of a public power and irrigation district having a chartered territory of more than one county in this state;

(v) An educational service unit;

(vi) The Educational Service Unit Coordinating Council;

(vii) An organization, including the governing body, of a risk management pool or its advisory committees organized in accordance with the Intergovernmental Risk Management Act;

(viii) A community college board of governors;

(ix) The Nebraska Brand Committee;

(x) A local public health department;

(xi) A metropolitan utilities district;

(xii) A regional metropolitan transit authority; and

(xiii) A natural resources district.

(b) The requirements for holding a meeting by means of virtual conferencing are as follows:

(i) Reasonable advance publicized notice is given as provided in subsection (1) of this section, including providing access to a dial-in number or link to the virtual conference;

(ii) In addition to the public's right to participate by virtual conferencing, reasonable arrangements are made to accommodate the public's right to attend at a physical site and participate as provided in section 84-1412, including reasonable seating, in at least one designated site in a building open to the public and identified in the notice, with: At least one member of the entity holding such meeting, or his or her designee, present at each site; a

recording of the hearing by audio or visual recording devices; and a reasonable opportunity for input, such as public comment or questions, is provided to at least the same extent as would be provided if virtual conferencing was not used;

(iii) At least one copy of all documents being considered at the meeting is available at any physical site open to the public where individuals may attend the virtual conference. The public body shall also provide links to an electronic copy of the agenda, all documents being considered at the meeting, and the current version of the Open Meetings Act; and

(iv) Except as otherwise provided in this subdivision or subsection (4) of section 79-2204, no more than one-half of the meetings of the state entities, advisory committees, boards, councils, organizations, or governing bodies are held by virtual conferencing in a calendar year. In the case of an organization created under the Interlocal Cooperation Act that sells electricity or natural gas at wholesale on a multistate basis or an organization created under the Municipal Cooperative Financing Act, the organization may hold more than one-half of its meetings by virtual conferencing if such organization holds at least one meeting each calendar year that is not by virtual conferencing. The governing body of a risk management pool that meets at least quarterly and the advisory committees of the governing body may each hold more than one-half of its meetings by virtual conferencing if the governing body's quarterly meetings are not held by virtual conferencing.

(3) Virtual conferencing, emails, faxes, or other electronic communication shall not be used to circumvent any of the public government purposes established in the Open Meetings Act.

(4) The secretary or other designee of each public body shall maintain a list of the news media requesting notification of meetings and shall make reasonable efforts to provide advance notification to them of the time and place of each meeting and the subjects to be discussed at that meeting.

(5) When it is necessary to hold an emergency meeting without reasonable advance public notice, the nature of the emergency shall be stated in the minutes and any formal action taken in such meeting shall pertain only to the emergency. Such emergency meetings may be held by virtual conferencing. The provisions of subsection (4) of this section shall be complied with in conducting emergency meetings. Complete minutes of such emergency meetings specifying the nature of the emergency and any formal action taken at the meeting shall be made available to the public by no later than the end of the next regular business day.

(6) A public body may allow a member of the public or any other witness to appear before the public body by means of virtual conferencing.

(7)(a) Notwithstanding subsections (2) and (5) of this section, if an emergency is declared by the Governor pursuant to the Emergency Management Act as defined in section 81-829.39, a public body the territorial jurisdiction of which is included in the emergency declaration, in whole or in part, may hold a meeting by virtual conferencing during such emergency if the

public body gives reasonable advance publicized notice as described in subsection (1) of this section. The notice shall include information regarding access for the public and news media. In addition to any formal action taken pertaining to the emergency, the public body may hold such meeting for the purpose of briefing, discussion of public business, formation of tentative policy, or the taking of any action by the public body.

(b) The public body shall provide access by providing a dial-in number or a link to the virtual conference. The public body shall also provide links to an electronic copy of the agenda, all documents being considered at the meeting, and the current version of the Open Meetings Act. Reasonable arrangements shall be made to accommodate the public's right to hear and speak at the meeting and record the meeting. Subsection (4) of this section shall be complied with in conducting such meetings.

(c) The nature of the emergency shall be stated in the minutes. Complete minutes of such meeting specifying the nature of the emergency and any formal action taken at the meeting shall be made available for inspection as provided in subsection (5) of section 84-1413.

(8) In addition to any other statutory authorization for virtual conferencing, any public body not listed in subdivision (2)(a) of this section may hold a meeting by virtual conferencing if:

(a) The purpose of the virtual meeting is to discuss items that are scheduled to be discussed or acted upon at a subsequent non-virtual open meeting of the public body;

(b) No action is taken by the public body at the virtual meeting; and

(c) The public body complies with subdivisions (2)(b)(i) and (2)(b)(ii) of this section.

Source: Laws 1975, LB 325, § 4; Laws 1983, LB 43, § 3; Laws 1987, LB 663, § 25; Laws 1993, LB 635, § 2; Laws 1996, LB 469, § 6; Laws 1996, LB 1161, § 1; Laws 1999, LB 47, § 2; Laws 1999, LB 87, § 100; Laws 1999, LB 461, § 1; Laws 2000, LB 968, § 85; Laws 2004, LB 821, § 38; Laws 2004, LB 1179, § 2; Laws 2006, LB 898, § 2; Laws 2007, LB199, § 9; Laws 2009, LB361, § 2; Laws 2012, LB735, § 1; Laws 2013, LB510, § 1; Laws 2017, LB318, § 1; Laws 2019, LB212, § 5; Laws 2020, LB148, § 3; Laws 2021, LB83, § 12; Laws 2022, LB742, § 1; Laws 2022, LB908, § 1; Laws 2022, LB922, § 13.

Note: The Revisor of Statutes has pursuant to section 49-769 correlated LB742, section 1, with LB908, section 1, and LB922, section 13, to reflect all amendments.

Note: Changes made by LB742 and LB908 became effective July 21, 2022. Changes made by LB922 became operative July 21, 2022.

Cross References

- **Intergovernmental Risk Management Act**, see section 44-4301.
- **Interlocal Cooperation Act**, see section 13-801.
- **Joint Public Agency Act**, see section 13-2501.

- **Municipal Cooperative Financing Act**, see section 18-2401.

Annotations

- Under subsection (1) of this section, the Legislature has imposed only two conditions on the public body's notification method of a public meeting: (1) It must give reasonable advance publicized notice of the time and place of each meeting and (2) it must be recorded in the public body's minutes. *City of Elkhorn v. City of Omaha*, 272 Neb. 867, 725 N.W.2d 792 (2007).
- An emergency is "(a)ny event or occasional combination of circumstances which calls for immediate action or remedy; pressing necessity; exigency; a sudden or unexpected happening; an unforeseen occurrence or condition." *Steenblock v. Elkhorn Township Bd.*, 245 Neb. 722, 515 N.W.2d 128 (1994).
- An agenda which gives reasonable notice of the matters to be considered at a meeting of a city council complies with the requirements of this section. *Pokorny v. City of Schuyler*, 202 Neb. 334, 275 N.W.2d 281 (1979).
- When notice is required, a notice of a special meeting of a city council posted in three public places at 10:00 p.m. on the day preceding the meeting is not reasonable advance publicized notice of a meeting as is required by this section. *Pokorny v. City of Schuyler*, 202 Neb. 334, 275 N.W.2d 281 (1979).
- Teacher waived right to object to lack of public notice in board of education employment hearing by voluntary participation in the hearing without objection. *Alexander v. School Dist. No. 17*, 197 Neb. 251, 248 N.W.2d 335 (1976).
- A county board of commissioners and a county board of equalization are not required to give separate notices when the notice states only the time and place that the boards meet and directs a citizen to where the agendas for each board can be found. *Wolf v. Grubbs*, 17 Neb. App. 292, 759 N.W.2d 499 (2009).
- A county board of equalization is a public body which is required to give advanced publicized notice of its meetings. *Wolf v. Grubbs*, 17 Neb. App. 292, 759 N.W.2d 499 (2009).
- Notice of recessed and reconvened meetings must be given in the same fashion as the original meeting. *Wolf v. Grubbs*, 17 Neb. App. 292, 759 N.W.2d 499 (2009).
- True notice of a meeting is not given by burying such in the minutes of a prior board proceeding. *Wolf v. Grubbs*, 17 Neb. App. 292, 759 N.W.2d 499 (2009).
- An agenda notice which merely stated "work order reports" was an inadequate notice under this section because it did not give interested persons knowledge that plans for a 345 kv transmission line through the district was going to be discussed and voted upon at the meeting. Inadequate agenda notice under this section meant there was a substantial violation of the public meeting laws; however, later actions by the board of directors cured the defects in notice, and such actions were in substantial compliance with the statute. *Hansmeyer v. Nebraska Pub. Power Dist.*, 6 Neb. App. 889, 578 N.W.2d 476 (1998).

84-1412. Meetings of public body; rights of public; public body; powers and duties.

(1) Subject to the Open Meetings Act, the public has the right to attend and the right to speak at meetings of public bodies, and all or any part of a meeting of a public body, except for closed sessions called pursuant to section 84-1410, may be videotaped, televised, photographed, broadcast, or recorded by any person in attendance by means of a tape recorder, a camera, video equipment, or any other means of pictorial or sonic reproduction or in writing.

(2) It shall not be a violation of subsection (1) of this section for any public body to make and enforce reasonable rules and regulations regarding the conduct of persons attending, speaking at, videotaping, televising, photographing, broadcasting, or recording its meetings, including meetings held by virtual conferencing. A body may not be required to allow citizens to speak at each meeting, but it may not forbid public participation at all meetings.

(3) No public body shall require members of the public to identify themselves as a condition for admission to the meeting nor shall such body require that the name of any member of the public be placed on the agenda prior to such meeting in order to speak about items on the agenda. The body shall require any member of the public desiring to address the body to identify himself or herself, including an address and the name of any organization represented by such person unless the address requirement is waived to protect the security of the individual.

(4) No public body shall, for the purpose of circumventing the Open Meetings Act, hold a meeting in a place known by the body to be too small to accommodate the anticipated audience.

(5) No public body shall be deemed in violation of this section if it holds its meeting in its traditional meeting place which is located in this state.

(6) No public body shall be deemed in violation of this section if it holds a meeting outside of this state if, but only if:

(a) A member entity of the public body is located outside of this state and the meeting is in that member's jurisdiction;

(b) All out-of-state locations identified in the notice are located within public buildings used by members of the entity or at a place which will accommodate the anticipated audience;

(c) Reasonable arrangements are made to accommodate the public's right to attend, hear, and speak at the meeting, including making virtual conferencing available at an in-state location to members, the public, or the press, if requested twenty-four hours in advance;

(d) No more than twenty-five percent of the public body's meetings in a calendar year are held out-of-state;

(e) Out-of-state meetings are not used to circumvent any of the public government purposes established in the Open Meetings Act; and

(f) The public body publishes notice of the out-of-state meeting at least twenty-one days before the date of the meeting in a legal newspaper of statewide circulation.

(7) Each public body shall, upon request, make a reasonable effort to accommodate the public's right to hear the discussion and testimony presented at a meeting.

(8) Public bodies shall make available at the meeting or the instate location for virtual conferencing as required by subdivision (6)(c) of this section, for examination and copying by members of the public, at least one copy of all reproducible written material to be discussed at an open meeting, either in paper or electronic form. Public bodies shall make available at least one current copy of the Open Meetings Act posted in the meeting room at a location accessible to members of the public. At the beginning of the meeting, the public shall be informed about the location of the posted information.

Source: Laws 1975, LB 325, § 5; Laws 1983, LB 43, § 4; Laws 1985, LB 117, § 2; Laws 1987, LB 324, § 5; Laws 1996, LB 900, § 1073; Laws 2001, LB 250, § 2; Laws 2004, LB 821, § 39; Laws 2006, LB 898, § 3; Laws 2008, LB962, § 1; Laws 2021, LB83, § 13.

Annotations

- To preserve an objection that a public body failed to make documents available at a public meeting as required by subsection (8) of this section, a person who attends a public meeting must not only object to the violation, but must make that objection to the public body or to a member of the public body. *Stoetzel & Sons v. City of Hastings*, 265 Neb. 637, 658 N.W.2d 636 (2003).

84-1413. Meetings; minutes; roll call vote; secret ballot; when; agenda and minutes; required on website; when.

(1) Each public body shall keep minutes of all meetings showing the time, place, members present and absent, and the substance of all matters discussed.

(2) Any action taken on any question or motion duly moved and seconded shall be by roll call vote of the public body in open session, and the record shall state how each member voted or if the member was absent or not voting. The requirements of a roll call or viva voce vote shall be satisfied by a public body which utilizes an electronic voting device which allows the yeas and nays of each member of such public body to be readily seen by the public.

(3) The vote to elect leadership within a public body may be taken by secret ballot, but the total number of votes for each candidate shall be recorded in the minutes.

(4) The minutes of all meetings and evidence and documentation received or disclosed in open session shall be public records and open to public inspection during normal business hours.

(5) Minutes shall be written or kept as an electronic record and shall be available for inspection within ten working days or prior to the next convened meeting, whichever occurs

earlier, except that cities of the second class and villages may have an additional ten working days if the employee responsible for writing or keeping the minutes is absent due to a serious illness or emergency.

(6) Beginning July 31, 2022, the governing body of a natural resources district, the city council of a city of the metropolitan class, the city council of a city of the primary class, the city council of a city of the first class, the county board of a county with a population greater than twenty-five thousand inhabitants, and the school board of a school district shall make available on such entity's public website the agenda and minutes of any meeting of the governing body. The agenda shall be placed on the website at least twenty-four hours before the meeting of the governing body. Minutes shall be placed on the website at such time as the minutes are available for inspection as provided in subsection (5) of this section. This information shall be available on the public website for at least six months.

Source: Laws 1975, LB 325, § 6; Laws 1978, LB 609, § 3; Laws 1979, LB 86, § 9; Laws 1987, LB 663, § 26; Laws 2005, LB 501, § 1; Laws 2009, LB361, § 3; Laws 2015, LB365, § 2; Laws 2016, LB876, § 1; Laws 2021, LB83, § 14; Laws 2022, LB742, § 2.

Effective Date: July 21, 2022

Annotations

- If a person present at a meeting observes and fails to object to an alleged public meetings laws violation in the form of a failure to conduct rollcall votes before taking actions on questions or motions pending, that person waives his or her right to object at a later date. *Hauser v. Nebraska Police Stds. Adv. Council*, 264 Neb. 944, 653 N.W.2d 240 (2002).
- Subsection (2) of this section does not require the record to state that the vote was by roll call, but requires only that the record show if and how each member voted. Neither does the statute set a time limit for recording the results of a vote, after which no corrections of the record can be made. If no intervening rights of third persons have arisen, a board of county commissioners has power to correct the record of the proceedings had at a previous meeting so as to make them speak the truth, particularly where the correction supplies some omitted fact or action and is done not to contradict or change the original record but to have the record show that a certain action was taken or thing done, which the original record fails to show. *State ex rel. Schuler v. Dunbar*, 214 Neb. 85, 333 N.W.2d 652 (1983).
- Failure by a public governing body, as defined under section 84-1409, R.R.S.1943, to take and record a roll call vote on an action, as required by section 84-1413(2), R.S.Supp.,1980, grants any citizen the right to sue for the purpose of having the action declared void. In this case such failure could not be later corrected by a nunc pro tunc order because there was no showing that a roll call vote on the disputed action was actually taken, and even if it was the record showed it was not recorded until over a year later. Sections 23-1301, R.R.S.1943,

and 23-1302, R.R.S.1943, make it the duty of the county clerk to record proceedings of the board of county commissioners. *State ex rel. Schuler v. Dunbar*, 208 Neb. 69, 302 N.W.2d 674 (1981).

- There is no requirement that a public body make a record of where notice was published or posted. *Wolf v. Grubbs*, 17 Neb. App. 292, 759 N.W.2d 499 (2009).

84-1414. Unlawful action by public body; declared void or voidable by district court; when; duty to enforce open meeting laws; citizen's suit; procedure; violations; penalties.

(1) Any motion, resolution, rule, regulation, ordinance, or formal action of a public body made or taken in violation of the Open Meetings Act shall be declared void by the district court if the suit is commenced within one hundred twenty days of the meeting of the public body at which the alleged violation occurred. Any motion, resolution, rule, regulation, ordinance, or formal action of a public body made or taken in substantial violation of the Open Meetings Act shall be voidable by the district court if the suit is commenced more than one hundred twenty days after but within one year of the meeting of the public body in which the alleged violation occurred. A suit to void any final action shall be commenced within one year of the action.

(2) The Attorney General and the county attorney of the county in which the public body ordinarily meets shall enforce the Open Meetings Act.

(3) Any citizen of this state may commence a suit in the district court of the county in which the public body ordinarily meets or in which the plaintiff resides for the purpose of requiring compliance with or preventing violations of the Open Meetings Act, for the purpose of declaring an action of a public body void, or for the purpose of determining the applicability of the act to discussions or decisions of the public body. It shall not be a defense that the citizen attended the meeting and failed to object at such time. The court may order payment of reasonable attorney's fees and court costs to a successful plaintiff in a suit brought under this section.

(4) Any member of a public body who knowingly violates or conspires to violate or who attends or remains at a meeting knowing that the public body is in violation of any provision of the Open Meetings Act shall be guilty of a Class IV misdemeanor for a first offense and a Class III misdemeanor for a second or subsequent offense.

Source: Laws 1975, LB 325, § 9; Laws 1977, LB 39, § 318; Laws 1983, LB 43, § 5; Laws 1992, LB 1019, § 126; Laws 1994, LB 621, § 2; Laws 1996, LB 900, § 1074; Laws 2004, LB 821, § 40; Laws 2006, LB 898, § 4.

Annotations

- The Legislature has granted standing to a broad scope of its citizens for the very limited purpose of challenging meetings allegedly in violation of the Open Meetings Act, so that they may help police the public policy embodied by the act. *Schauer v. Grooms*, 280 Neb. 426, 786 N.W.2d 909 (2010).

- Any citizen of the state may commence an action to declare a public body's action void. *City of Elkhorn v. City of Omaha*, 272 Neb. 867, 725 N.W.2d 792 (2007).
- The reading of ordinances constitutes a formal action under subsection (1) of this section. *City of Elkhorn v. City of Omaha*, 272 Neb. 867, 725 N.W.2d 792 (2007).
- If a person present at a meeting observes a public meetings law violation in the form of an improper closed session and fails to object, that person waives his or her right to object at a later date. *Wasikowski v. Nebraska Quality Jobs Bd.*, 264 Neb. 403, 648 N.W.2d 756 (2002).
- Under the Public Meetings Act, a county lacks capacity to maintain an action to declare its official conduct "void" for noncompliance with the act. *County of York v. Johnson*, 230 Neb. 403, 432 N.W.2d 215 (1988).
- When a petitioner under this section is successful in the district court, that court may allow attorney fees. *Tracy Corp. II v. Nebraska Pub. Serv. Comm.*, 218 Neb. 900, 360 N.W.2d 485 (1984).
- Informal discussions between the Tax Commissioner and the State Board of Equalization in which instructions were clarified, with such clarification leading to the amendment of hearing notices, did not constitute a public meeting subject to the provisions of this section. *Box Butte County v. State Board of Equalization and Assessment*, 206 Neb. 696, 295 N.W.2d 670 (1980).
- The right to collaterally attack an order made in contravention of the Public Meeting Act must occur within a period of one year as is specifically provided by this section. *Witt v. School District No. 70*, 202 Neb. 63, 273 N.W.2d 669 (1979).
- Statutory change, requiring "publicized notice" for board of education employment hearings, occurring between dates meeting scheduled and conducted, held not to void proceedings. *Alexander v. School Dist. No. 17*, 197 Neb. 251, 248 N.W.2d 335 (1976).
- Voiding an entire meeting is a proper remedy for violations of the Open Meetings Act. Once a meeting has been declared void pursuant to Nebraska's public meetings law, board members are prohibited from considering any information obtained at the illegal meeting. *Wolf v. Grubbs*, 17 Neb. App. 292, 759 N.W.2d 499 (2009).
- Actions by the board of directors were merely voidable under this section, and not void. Pursuant to subsection (3) of this section, the plaintiffs were awarded partial attorney fees because they were successful in having the court declare that the board of directors was in substantial violation of the statute, even though the plaintiffs did not get the relief requested of having the board's actions declared void. *Hansmeyer v. Nebraska Pub. Power Dist.*, 6 Neb. App. 889, 578 N.W.2d 476 (1998).

--

Source: http://nebraskalegislature.gov/laws/display_html.php?begin_section=84-1407&end_section=84-1414

Date: July 2022

2. PRAYER

3. NATIONAL ANTHEM AND PLEDGE OF ALLEGIANCE

4. CONSENT AGENDA - The following items are considered to be routine by the city council and will be enacted by one motion. There will be no separate discussion of these items unless a city council member or citizen so requests, in which event the item will be removed from consent status and considered in its normal sequence on the agenda.

4.A. Minutes of May 15, 2023, City Council meeting.

PROCEEDINGS OF CITY COUNCIL
May 15, 2023

A regular meeting of the mayor and city council of the City of Columbus, Nebraska, was convened in open and public session on May 15, 2023, at 7 p.m. in the Council Chambers, 1369 25 Avenue, Columbus, Nebraska.

Notice of this meeting was given in advance thereof by publication in the Columbus Telegram on April 26, 2023, with a copy of the proof of publication being on file in the office of the city clerk. Notice of this meeting was given simultaneously to the mayor and members of the city council, with a copy of the acknowledgement of receipt of notice being on file in the office of the city clerk. Availability of the agenda was communicated in the advance notice and in the notice to the mayor and city council of this meeting. All proceedings hereafter shown were taken while the convened meeting was open to the public.

1. **STATEMENT OF COMPLIANCE WITH OPEN MEETINGS ACT AND ROLL CALL:** Mayor Bulkley announced that a copy of the Open Meetings Act is posted in the meeting room. Present were Mayor James Bulkley and Council Members Beth Augustine-Schulte, Charlie Bahr, Hope Freshour, Troy Hiemer, Rich Jablonski, Kat Lopez, Prent Roth, and Ron Schilling. City staff members included City Attorney Neal Valorz, City Administrator Tara Vasicek, City Clerk Janelle Kline, City Engineer Rick Bogus, Police Chief Chuck Sherer, Public Works Director Chuck Sliva, Public Property Director Doug Moore, Human Resources Tammy Orender, Library Director Jeri Hopkins, Planning & Economic Development Director Jean Van Iperen, Public Communications Manager Matt Lindberg, and Library Assistant Joan Von Ruden-Kruger.
2. **PRAYER:** Augustine-Schulte led in prayer.
3. **NATIONAL ANTHEM AND PLEDGE OF ALLEGIANCE:** The National Anthem was sung and the Pledge of Allegiance was recited.

Mayor Bulkley introduced new Library Director Jeri Hopkins.
4. **CONSENT AGENDA:** Vasicek stated that the following items are considered routine by the city council and will be enacted by one motion. She pointed out there will be no separate discussion of these items unless a city council member or citizen so requests, in which event the item will be removed from consent status and considered in its normal sequence on the agenda. The items on the consent agenda were approved as presented with a motion by Augustine-Schulte and a second by Schilling. Augustine-Schulte, Bahr, Freshour, Hiemer, Jablonski, Lopez, Roth, and Schilling voted "Aye" and none voted "Nay".
- 4.A. **Minutes of May 1, 2023, City Council meeting.**

PROCEEDINGS OF CITY COUNCIL

May 15, 2023

Page 2

- 4.B. Minutes of May 2, 2023, Civil Service Commission meeting certifying police officer candidates Khamden Cone and Dustin Balesten.**
- 4.C. Bid from Dale R. Johnson dba Johnson Trucking for one-year supply of road gravel in the amount of \$24.90 per cubic yard delivered or \$19.45 per cubic yard if picked up.**
- 4.D. Resolution No. R23-67 authorizing payment of various improvement projects.** Resolution No. R23-67 is entitled: A RESOLUTION OF THE MAYOR AND COUNCIL OF THE CITY OF COLUMBUS, NEBRASKA, TO AUTHORIZE AND DIRECT THAT A CHECK BE ISSUED AND MADE PAYABLE TO THE RESPECTIVE CONTRACTOR(S) FOR LABOR, EQUIPMENT, AND MATERIALS FURNISHED FOR IMPROVEMENTS IN THE FOLLOWING DESIGNATED DISTRICTS AND PROJECTS WITHIN THE CITY OF COLUMBUS, ALL AS SET FORTH ON THE ATTACHED CERTIFICATES OF PROGRESS PREPARED BY THE RESPECTIVE SPECIAL ENGINEER TO WIT BOYD JONES CONSTRUCTION COMPANY, COMMUNITY BUILDING, \$618,718.34; GEHRING CONSTRUCTION AND READY MIX CO. INC., SID NO. 189 48 AVENUE FROM 23 STREET TO SOUTH OF BRADSHAW PARK ENTRANCE AND CONCRETE PAVING IMPROVEMENTS 2023, \$122,960.70; KOCH EXCAVATING, QUAIL RUN GOLF COURSE RESTORATION, \$10,000; AND RUTJENS CONSTRUCTION, LOST CREEK PARKWAY SEWER, \$732,564.00.
- 4.E. Finance Department reports.**
- 4.F. Payroll and bills on file:** B=Bond Payments; CP=Capital Projects; E=Expenses; G=Grants; I=Insurance L=License; M=Membership; R=Refund; S=Service & Supplies; T=Training 5/26/23 Payroll \$741,701.04; 1200.Aero 1,000.00 S; 911 Custom 4,884.00 S; 911 Training 834.00 T; A to Z Messaging 125.00 S; Ace Hrdwr 844.41 S; Ace Sanitation 110.00 S; Advance Auto 69.60 S; D Aldrich 55.00 L; Animal Care Eq 1,198.92 S; Aqua-Chem 7,523.00 S; Aqua-Pure 10,596.85 S; Arnold Motor 126.82 S; AT&T Mobility 10.16 S; AVI Sys 36,113.14 CP; Axon 495.00 T; Behlen Tow 1,425.00 S; Black Hills Energy 3,535.64 S; Blackstone Pub 96.00 S; BookPage 402.00 S; Boyd Jones 618,718.34 CP; BVH Architecture 17,639.52 CP; CBS 9.20 S; Cntr Pnt LP 94.08 S; Cntrl Comm Clg 148.00 T; Century Link 930.00 S; Chrome N' Steel 961.07 S; City of Col 11,635.52 S; Club Prophet Sys 710.00 S; CNC Repair 6,391.96 S; Col Area Chamber 9,160.00 S; CCS 300.44 S; Col Custom Emb 572.00 S; Col Telegram 949.46 S; Col Tire 8,061.95 S; Confluence 10,567.23 CP; Conn Pt 8,705.00 S; Crnhskr Pwr 895.06 S; Culligan 137.50 S; D&K Prod 8,809.10 S; K De Roos 30.72 E; Dell 8,720.90 S; Demco 562.06 S; Dept of Correctional 1,950.00 S; D Dunbar 49,609.75 E,S; Eakes 50,794.54 CP,S; Ed M. Feld Eq 9,635.36 CP; Electrical Eng 38.99 S; Envisionware 952.59 S; Evident 1,686.19 S; Fastenal 146.61 S; First Natl Bank 24,104.87 E; Frontier 2,448.31 S; Full Throttle 1,026.30 S; Gale 75.17 S; Galls 1,116.44 S; Gehring Const 126,532.85 CP, S; Gerhold 891.44 S; Godfather's Pizza 98.00 E; GolfNow 185.66 S; Graybar Electric 53.88 CP; Grt Plains Bldg 595.64 S; Grt

PROCEEDINGS OF CITY COUNCIL

May 15, 2023

Page 3

Plains Comm 239.95 S; Grimes Asphalt 1,080.00 S; Gunslingers 45.00 S; Hadley-Braithwait 203.85 S; Hawkins 4,101.20 S; Heartland Nat Gas 2,904.14 S; Hrtlnd Office Clnrs 500.00 S; M Howerter 616.00 S; Hy-Vee 310.10 S; Ingram Libry 192.57 S; Iowa Pump Wks 3,197.00 S; Jackson Serv 1,715.45 S; John Deere Financial 237.25 S; Kelly Supply 185.41 S; Kirkham Michael & Assoc 1,894.06 CP; Koch Excav 10,000.00 CP; Language Line 256.42 S; Larm 37,035.94 I; P Laska 74.35 S; Light & Siren 1,870.00 CP; Lincoln Winwater Wrks 416.26 S; Lingo 51.68 S; C Lloyd 15.00 T; Loseke Lk Stop 18.45 S; Loup Pwr 81,642.80 S; M&L 984.15 S; MacQueen Eq 1,296.88 S; Mailbox 118.56 S; J Marksmeier 186.00 S; Matheson-Linweld 316.59 S; McMill CPA 2,800.00 S; Medline Ind 398.79 S; Menards 1,529.16 S; MW Lab 139.25 S; MW Tape 124.44 S; MW Turf 341.83 S; Mike's Tow 1,050.00 S; Motion Ind 1,327.26 S; Motion Pic Lic 310.20 S; NAPA 292.81 S; NE Golf & Turf 18,360.00 S; NE Law Enforce 20.05 S; NE Notary 100.00 T; NE Survey Repsit 5.00 S; NE NE Area 12,026.00 M; NE NE Economic 206.25 S; NE NE Solid 57,736.67 S; Noswett Fencing 125.00 S; Occupational Health 2,589.00 S; Olson's Pest 492.50 S; One Call Conc 505.40 S; One Source 1,615.00 S; O'Reilly 260.14 S; Paper Tiger 103.80 S; Pete Lien & Sons 6,678.68 S; Petty Cash 2,647.42 S; PGA 587.00 M; Pictometry Inter 18,150.00 CP; Platte Co 3,408.00 S; Platte County Hwy 2,812.50 S; Pomp's Tire 153.00 S; Port-A-Johns 375.00 S; Precision Wd 63.00 S; Premier Prprty Mngmnt 10,609.99 S; Price Chopper 1,672.97 S; Quadient Fin 1,000.00 S; Reardon 62.98 S; Rembolt Ludtke LLP 1,555.00 S; RFCC 250.00 S; J Rosenberg 1,000.00 S; E Rosenthal 73.25 R; Rutjens Cnstr 732,564.00 CP; Rutt's Htng 1,488.75 S; RVW 456.50 S; Sand Crk Cnstr 5,200.00 CP; Sapp Bros 27,069.15 S; C Seedschlag 96,872.64 CP; Security Eq 82,408.20 CP; Seiler Instr 490.00 CP; Shelvin 6,583.00 S; Shelvin Sup 366.20 S; Sipple Hansen Emerson Schumacher Klutman & Valorz 4,221.45 S; Stanard & Assoc 161.50 S; St NE Dept Rev 56,818.51 S; Sunset Law Enf 5,437.20 S; Super Svr 318.02 S; Surplus Prop 5,700.00 S; Sysco 9,501.20 S; Telecomm Sys 1,554.00 S; Tire Outlet 579.00 S; TK Elevator Corp 228.75 S; Too Fast Sup 35.23 S; Tractor Sply 243.85 S; Truck Ctr Co 1,341.02 S; Twin Rivers 338.00 S; U&I 204.50 S; USA Blue Bk 5,239.09 S; C Van Dyke 146.50 S; T Vasicek 100.87 T; Verizon 56.80 S; Verizon Wireless 9,028.79 S; Waste Conn 250.96 S; Wtr Environ Federation 85.00 M; Wellness Prtnrs 10.00 S; WT Pnt Imp 169.49 S; Wise Buys 1,326.00 S; Zoll 6,563.00 S; TOTAL \$3,166,216.85.

5. **APPROVAL OF MINUTES:** Included in Consent Agenda
6. **SPECIAL PRESENTATIONS:** None
7. **PUBLIC HEARINGS:** None.
8. **PETITIONS AND COMMUNICATIONS:** None
9. **REPORTS OF CITY OFFICES:** Included in Consent Agenda
10. **REPORTS OF COUNCIL COMMITTEES:**

10.A. PUBLIC PROPERTY, SAFETY, AND WORKS COMMITTEE - May 8, 2023

10.A.1. Right-of-way agreement with Dusters for patio seating at 2804 13 Street.

The Public Property, Safety, and Works Committee recommended approval of the easement agreement with Dusters. The report was adopted with a motion by Bahr and a second by Hiemer. Augustine-Schulte, Bahr, Freshour, Hiemer, Jablonski, Lopez, Roth, and Schilling voted "Aye" and none voted "Nay".

10.A.2. Plans and specifications for Frankfort Square improvements.

There was no recommendation from the Public Property, Safety, and Works Committee as the motion to approve the plans and specifications for Frankfort Square improvements failed due to a tie vote. Vasicek referred to downtown revitalization planning that began nearly two years ago and said RDG Planning & Design (RDG) was hired to conduct a study of downtown needs. RDG held a number of community forums and engaged various stakeholders across the community and concluded that Frankfort Square was under-utilized when there were no scheduled organized events. Discussions were held to determine and create a plan for improvements that would encourage park usage on a daily basis. Vasicek reported that the first phase of the plan includes construction of a parking pad off 26 Avenue for food trucks; an internal sidewalk on the east quadrant connecting existing sidewalks; two concrete pads for picnic tables; relocation of one bench, the UPRR bell structure, and 25 flag pole holders; and removal of one tree. She noted that \$125,000 is budgeted this fiscal year for the first phase and pointed out the largest concern expressed at the Public Property, Safety, and Works Committee was the concrete pad for food trucks. Sharon Bahr, 1410 14 Street, read a communication she sent to council members inquiring about commitments from food truck vendors and expressing opposition to replacing green space with concrete in the park. Jane Tooley, 6397 66 Street, and Kylie Sedlacek, 2411 13 Street, expressed opposition to the concrete pad for food trucks, removal of the tree, and relocation of flag holders. Extensive discussion was held with regard to alternative options such as relocation of the concrete parking pad, installation of curb cuts and electricity for parking on the street, establishing policy and fees for use of a concrete pad, and rearranging flag holders to make room for all flags. Approval was granted to proceed with the plans and specifications for Frankfort Square improvements as amended by removing the concrete parking pad, adding electricity as needed, relocating flag holders to keep all flags in Frankfort Square, and considering the establishment of a policy and fee for use of a concrete pad with a motion by Jablonski and a second by Hiemer. Augustine-Schulte, Freshour, Hiemer, Jablonski, Lopez, Roth, and Schilling voted "Aye" and Bahr voted "Nay".

10.B. PUBLIC FINANCE, JUDICIARY, AND PERSONNEL COMMITTEE - May 9, 2023

10.B.1. Update to Municipal Recognition Program. The Public Finance, Judiciary, and Personnel Committee recommended the Municipal Recognition Program be amended to receive nominations for productivity awards annually with up to

four awardees selected to receive a maximum of \$1,000 each. The report was adopted with a motion by Augustine-Schulte and a second by Roth. Augustine-Schulte, Bahr, Freshour, Hiemer, Jablonski, Lopez, Roth, and Schilling voted "Aye" and none voted "Nay".

10.B.2. Amend Schedule of Fees for code enforcement. The Public Finance, Judiciary, and Personnel Committee recommended the Schedule of Fees for code enforcement be amended to also add an equipment fee for weed abatement and removal of snow and ice. The report was adopted with a motion by Jablonski and a second by Lopez. Augustine-Schulte, Bahr, Freshour, Hiemer, Jablonski, Lopez, Roth, and Schilling voted "Aye" and none voted "Nay".

11. REPORTS OF SPECIAL COMMITTEES: None

12. REPORTS ON LEGISLATION: None

13. NEW BUSINESS:

13.A. Appointment of Jayden French as police officer. Augustine-Schulte read a brief resume and the mayor's appointment of Jayden French as police officer was ratified with a motion by Hiemer and a second by Bahr. Augustine-Schulte, Bahr, Freshour, Hiemer, Jablonski, Lopez, Roth, and Schilling voted "Aye" and none voted "Nay". French thanked the mayor and council for the appointment.

13.B. Application of Quail Meadows, LLC for preliminary plat of Quail Meadows Addition (south of 1 Street between 10 Avenue and 14 Avenue). (Planning Commission recommends approval.) The preliminary plat of Quail Meadows Addition was approved with a motion by Augustine-Schulte and a second by Hiemer. Augustine-Schulte, Bahr, Freshour, Hiemer, Jablonski, Lopez, Roth, and Schilling voted "Aye" and none voted "Nay".

13.C. Application of Micek Brothers, LLC for special designated liquor license on 25 Avenue from 70 feet north of 12 Street to 12 Street, from 9 p.m. to 12 a.m. August 3, 6 p.m. to 12 a.m. August 4, and 10 a.m. to 1 a.m. August 5, 2023, for 100-year anniversary party. The application of Micek Brothers, LLC for a special designated liquor license was approved with a motion by Lopez and a second by Bahr. Augustine-Schulte, Bahr, Freshour, Hiemer, Jablonski, Lopez, Roth, and Schilling voted "Aye" and none voted "Nay".

13.D. Application of The Friedhof Room at Schwesers for special designated liquor license on 27 Avenue from 13 Street south to the alley, from 4 p.m. to 12:30 a.m. June 16, 2023, for street festival. The application of The Friedhof Room at Schwesers for a special designated liquor license was approved with a motion by Augustine-Schulte and a second by Schilling. Augustine-Schulte, Bahr, Freshour, Hiemer, Jablonski, Lopez, Roth, and Schilling voted "Aye" and none voted "Nay".

- 13.E. Quote from Nebraska Golf & Turf in the amount of \$18,360 for 102 golf cart batteries at Quail Run Golf Course.** The quote from Nebraska Golf & Turf for golf cart batteries was accepted with a motion by Bahr and a second by Lopez. Augustine-Schulte, Bahr, Freshour, Hiemer, Jablonski, Lopez, Roth, and Schilling voted “Aye” and none voted “Nay”.
- 13.F. Quote from Gehring Construction & Ready Mix Co., Inc. in the amount of \$39,787.50 for Frankfort Square improvements.** The quote from Gehring Construction & Ready Mix Co., Inc. for Frankfort Square improvements was accepted with an amendment to exclude the concrete pad from the plans and make other modifications as needed with a motion by Augustine-Schulte and a second by Freshour. Augustine-Schulte, Freshour, Hiemer, Jablonski, Lopez, Roth, and Schilling voted “Aye” and Bahr voted “Nay”.
- 13.G. Comments from mayor and city council members.** Jablonski thanked the members of the Downtown Business Improvement District Board and said their input on the Frankfort Square improvements is greatly appreciated. Schilling referred to the recent baseball tournament held in Columbus noting he received a lot of positive comments regarding the hotels and friendly community.
- 14. RESOLUTIONS:**
- 14.A. Resolution No. R23-68 approving easement agreement with Gottberg Auto Company, LLC dba Dusters for patio seating at 2801 13 Street.** Resolution No. R23-68 entitled: A RESOLUTION OF THE MAYOR AND COUNCIL OF THE CITY OF COLUMBUS, NEBRASKA, APPROVING AN EASEMENT AGREEMENT WITH DUSTERS FOR OUTDOOR SEATING IN CONJUNCTION WITH THE OPERATION OF ITS BUSINESS, A COPY OF WHICH IS ATTACHED HERETO AND INCORPORATED HEREIN; TO AUTHORIZE THE MAYOR TO EXECUTE THE SAME ON BEHALF OF THE CITY; AND TO REPEAL ALL RESOLUTIONS OR PORTIONS THEREOF IN CONFLICT HEREWITH was adopted with a motion by Bahr and a second by Hiemer. Augustine-Schulte, Bahr, Freshour, Hiemer, Jablonski, Lopez, Roth, and Schilling voted “Aye” and none voted “Nay”.
- 14.B. Resolution No. R23-69 approving assignment and assumption of lease from Winfield Solutions, LLC to Central Valley Ag Cooperative for hangar and load pad space at airport.** Resolution No. R23-69 entitled: A RESOLUTION OF THE MAYOR AND COUNCIL OF THE CITY OF COLUMBUS, NEBRASKA, APPROVING AN ASSIGNMENT AND ASSUMPTION OF LEASE AND A CONSENT BY LESSOR FROM WINFIELD SOLUTIONS, LLC TO CENTRAL VALLEY AG COOPERATIVE FOR HANGAR AND LOAD PAD SPACE AT THE COLUMBUS AIRPORT, A COPY OF WHICH IS ATTACHED HERETO AND INCORPORATED HEREIN BY THIS REFERENCE; TO AUTHORIZE THE MAYOR TO EXECUTE THE SAME ON BEHALF OF THE CITY; AND TO REPEAL ALL RESOLUTIONS OR PORTIONS THEREOF IN CONFLICT HEREWITH was adopted with a motion

by Lopez and a second by Augustine-Schulte. Augustine-Schulte, Bahr, Freshour, Hiemer, Jablonski, Lopez, Roth, and Schilling voted "Aye" and none voted "Nay".

14.C. Resolution No. R23-70 approving Memorandum of Understanding with Loup Public Power District for use of property for firing range located north of Loup Canal bridge off 83 Street. Resolution No. R23-70 entitled: A RESOLUTION OF THE MAYOR AND COUNCIL OF THE CITY OF COLUMBUS, NEBRASKA, APPROVING A MEMORANDUM OF UNDERSTANDING WITH LOUP PUBLIC POWER DISTRICT FOR A FIREARM RANGE TO BE USED BY THE COLUMBUS POLICE DEPARTMENT, A COPY OF WHICH IS ATTACHED HERETO AND INCORPORATED HEREIN BY REFERENCE; TO AUTHORIZE THE MAYOR TO EXECUTE THE SAME; AND TO REPEAL ALL RESOLUTIONS OR PORTIONS THEREOF IN CONFLICT HEREWITH was adopted with a motion by Roth and a second by Jablonski. Augustine-Schulte, Bahr, Freshour, Hiemer, Jablonski, Lopez, Roth, and Schilling voted "Aye" and none voted "Nay".

14.D. Resolution No. R23-71 approving design build agreement with Nemaha Landscape Construction, Inc. dba Nemaha Sports Construction in the guaranteed maximum price amount of \$579,000 with estimated rebate amount of \$102,500 for final cost of \$477,000 for football field turf replacement at Pawnee Park Memorial Stadium. It was noted that the total dollar amount of this project will decrease as the plans to paint the letter "C" on the field will be removed. Resolution No. R23-71 entitled: A RESOLUTION OF THE MAYOR AND COUNCIL OF THE CITY OF COLUMBUS, NEBRASKA, APPROVING THE DESIGN BUILD AGREEMENT BETWEEN OWNER AND NEMAHA LANDSCAPE CONSTRUCTION, INC. DBA NEMAHA SPORTS CONSTRUCTION IN THE GUARANTEED MAXIMUM PRICE AMOUNT OF \$579,000 FOR THE FOOTBALL FIELD TURF REPLACEMENT AT PAWNEE PARK MEMORIAL STADIUM, A COPY OF WHICH IS ATTACHED HERETO AND INCORPORATED HEREIN BY REFERENCE; TO AUTHORIZE THE MAYOR TO EXECUTE THE SAME ON BEHALF OF THE CITY; AND TO REPEAL ALL RESOLUTIONS OR PORTIONS THEREOF IN CONFLICT HEREWITH was adopted as amended to eliminate the "C" logo from the football field with a motion by Schilling and a second by Hiemer. Augustine-Schulte, Bahr, Freshour, Hiemer, Jablonski, Lopez, Roth, and Schilling voted "Aye" and none voted "Nay".

14.E. Resolution No. R23-72 approving agreement with B2 Environmental, Inc. in the amount of \$46,182.50 for hazardous material abatement of former Columbus Rescue Mission building as part of community building project. Resolution No. R23-72 entitled: A RESOLUTION OF THE MAYOR AND COUNCIL OF THE CITY OF COLUMBUS, NEBRASKA, APPROVING AN AGREEMENT WITH B2 ENVIRONMENTAL, INC. IN THE LUMP SUM AMOUNT OF \$46,182.50 FOR HAZARDOUS MATERIAL ABATEMENT

SERVICES OF THE FORMER COLUMBUS RESCUE MISSION BUILDING AT 1471 25 AVENUE IN CONJUNCTION WITH THE COMMUNITY BUILDING PROJECT, A COPY OF WHICH IS ATTACHED HERETO AND INCORPORATED HEREIN BY THIS REFERENCE; TO AUTHORIZE THE MAYOR TO EXECUTE THE SAME ON BEHALF OF THE CITY; AND TO REPEAL ALL RESOLUTIONS OR PORTIONS THEREOF IN CONFLICT HEREWITH was adopted with a motion by Hiemer and a second by Augustine-Schulte. Augustine-Schulte, Bahr, Freshour, Hiemer, Jablonski, Lopez, Roth, and Schilling voted "Aye" and none voted "Nay".

- 14.F. Resolution No. R23-73 amending Schedule of Fees for abatement, removal of snow and ice, and towing for code enforcement.** Resolution No. R23-73 entitled: A RESOLUTION OF THE MAYOR AND COUNCIL OF THE CITY OF COLUMBUS, NEBRASKA, AMENDING SCHEDULE OF FEES FOR CODE ENFORCEMENT BY ADDING THE FOLLOWING FEES: \$50 ADMINISTRATIVE FEE FOR ABATEMENTS, REMOVAL OF SNOW AND ICE, AND TOWING; \$85 PER HOUR FOR WEED ABATEMENT AND REMOVAL OF SNOW AND ICE; \$15 EQUIPMENT FEE FOR WEED ABATEMENT AND REMOVAL OF SNOW AND ICE; ACTUAL CHARGE FOR DUMPING FOR ABATEMENTS; AND POSTAGE AND LEGAL FEES FOR TOWING; AND TO REPEAL ALL RESOLUTIONS OR PORTIONS THEREOF IN CONFLICT HEREWITH was adopted with a motion by Jablonski and a second by Bahr. Augustine-Schulte, Bahr, Freshour, Hiemer, Jablonski, Lopez, Roth, and Schilling voted "Aye" and none voted "Nay".

15. ORDINANCES ON FIRST READING:

- 15.A. Ordinance No. 23-04 amending Sections 92.02 and 92.03 of Chapter 92 of Title IV of Columbus City Code to define scrapping and declare scrapping in residential zones as a nuisance.** On its first reading, Ordinance No. 23-04 entitled: AN ORDINANCE OF THE MAYOR AND COUNCIL OF THE CITY OF COLUMBUS, NEBRASKA, AMENDING SECTIONS 92.02 AND 92.03 OF CHAPTER 92 OF TITLE IX OF ORDINANCE NO. 05-47 (COLUMBUS CITY CODE) TO DEFINE SCRAPPING AND DECLARE SCRAPPING IN RESIDENTIAL ZONES AS NUISANCES; REPEALING ALL ORDINANCES OR PORTIONS THEREOF IN CONFLICT HEREWITH; PROVIDING FOR AN EFFECTIVE DATE; AND PROVIDING FOR THE PUBLICATION OF THIS ORDINANCE IN PAMPHLET FORM was read by number only.

16. ORDINANCES ON SECOND READING: None

17. ORDINANCES ON THIRD READING: None

18. CONSIDERATION OF PAYROLL AND BILLS ON FILE: Included in Consent Agenda.

19. UNFINISHED BUSINESS: None

PROCEEDINGS OF CITY COUNCIL

May 15, 2023

Page 9

20. ADJOURNMENT: The meeting adjourned at 8:10 p.m.

Presented and approved this 5 day of June, 2023.

OFFICE OF THE CITY CLERK

:Janelle Kline

4.B. Change date of first meeting in July 2023 to 7 p.m., Wednesday, July 5, 2023, due to move to new community building.

4.C. Reappointment of Robert Elsasser to Planning Commission for three-year term.

The City of **Columbus**

RESPONSIBLE • **RESPONSIVE** • **REPUTABLE**
Administration Office (402) 562-4232 Fax (402) 563-1380

MEMORANDUM

DATE: May 31, 2023
TO: City Council Members
FROM: James B. Bulkley, Mayor
SUBJECT: Reappointment

With your permission, I wish to submit the following names to you for reappointment to the Planning Commission at the June 5, 2023, City Council meeting. Per Council Rules, the two-week waiting period is automatically waived for someone who is reappointed to the same or similar position.

PLANNING COMMISSION: (Three-Year Term)

Robert Elsasser

James B. Bulkley, Mayor
City of Columbus

4.D. Reappointment of Toby Goc, Thomas A. Loseke, Neil Carnes, Mark Bierman, and Bill Elton (as alternate) to Board of Adjustment for three-year terms.

The City of **Columbus**

RESPONSIBLE • RESPONSIVE • REPUTABLE

Administration Office (402) 562-4232

Fax (402) 563-1380

MEMORANDUM

DATE: May 24, 2023
TO: City Council Members
FROM: James B. Bulkley, Mayor
SUBJECT: Reappointments

With your permission, I wish to submit the following names to you for reappointment at the June 5, 2023, City Council meeting. Per Council Rules, the two-week waiting period is automatically waived for someone who is reappointed to the same or similar position.

BOARD OF ADJUSTMENT: (Three Year Term)

Toby Goc
Thomas A. Loseke
Neil Carnes
Mark Bierman
Bill Elton (as Alternate)

James B. Bulkley, Mayor

4.E. Title III-B (supportive services), Title III-C (nutrition), and Title III-E (family caregiver support) grant funding from Northeast Nebraska Area Agency on Aging for senior center.

MEMORANDUM

DATE: June 1, 2023
TO: Tara Vasicek, City Administrator
FROM: Doug Moore, Public Property Director
SUBJECT: 2023-2024 Acceptance of Grant Contracts and Nutrition Agreements with Northeast Nebraska Area Agency on Aging (NENAAA)

RECOMMENDATION:

Staff recommends the acceptance of the III-B Supportive Services Contract, III-C Nutrition Contract, and the III-E Family Caregiver Support Contract from the Northeast Nebraska Area Agency on Aging (NENAAA).

DISCUSSION:

The NENAAA administers federal and state activity subsidies (III-B), meal subsidies (III-C), and caregiver subsidies (III-E) for senior centers in northeast Nebraska. Our application for funds has received its final approval and formal acceptance of the grant contracts is now required.

FISCAL IMPACT:

The III-B activity subsidy grant provides a maximum of \$42,549 in federal and state funding. The III-C nutrition agreements provides for a maximum of \$83,253 in federal and state funding. The III-E caregiver support grant provides a maximum of \$3,500 in federal and state funding. These funds will cover approximately 28% of the cost of the Senior Center operation.

ALTERNATIVES:

If we do not accept these funds, additional funding would be necessary from other sources in order to maintain services at the Columbus Senior Center.

CONCURRENCE:

The agreements and grant notifications have been reviewed by the Senior Center Manager and Finance Director and they concur with the acceptance of the award.

SIGNATURE:

DEPARTMENT HEAD *Douglas A Moore*

CITY ADMINISTRATOR APPROVAL *Tara Vasicek*

III B SUPPORTIVE SERVICES CONTRACT

This Contract is made and entered into this 1st day of July, 2023 by and between the Northeast Nebraska Area Agency on Aging, Norfolk, Nebraska, hereinafter called “Agency” and City of Columbus hereinafter called “Contractor”.

1. **RECITALS.**

(A) Agency is a single purpose unit of government of the State of Nebraska authorized to provide services for persons 60 years of age or older within the Northeast Nebraska planning and service area.

(B) Agency has received a subaward from the Nebraska Department of Health and Human Services State Unit on Aging, an agency of the State of Nebraska, to provide supportive services to persons 60 years of age and older within the Northeast Nebraska planning and service area.

(C) Contractor is presently operating as a provider of supportive services and is capable and desirous of providing such supportive services as are hereinafter enumerated for and on behalf of the Agency.

NOW, THEREFORE, IT IS AGREED AS FOLLOWS:

2. **AGREEMENT.**

Contractor is hereby retained and appointed by Agency to provide supportive services to designated sites (see page 10 #19 (G)), as a part of the III B program for the elderly within the Northeast Nebraska planning and service area and any other area designated by Agency.

3. **ELIGIBILITY.** All participants that are 60 years of age or older are eligible for III B supportive services.

4. **DEFINITIONS of III B SUPPORTIVE SERVICES:**

(A) **Information and Assistance:** (I & A)

A service when information is requested:

- Provides individuals with information on services available within the community, including information relating to assistive technology.
- Assesses the problems and capabilities of the individuals;
- links individuals to the services and opportunities that are available;
- to the maximum extent practicable, ensures that individuals receive the services needed and are aware of opportunities available by establishing adequate follow-up procedures
- The follow-up may include offering to call back to ensure the individual received the information requested. The client can request or decline follow-up.

Must be a one-on-one contact.

Unit: one request for information = 1 unit

Supporting documentation: I & A form provided by the Agency.

(B) Nutrition Education:

Program to promote better health by providing accurate and culturally sensitive nutrition, physical fitness, or health information (as it relates to nutrition). Information that is consistent with the current Dietary Guidelines for Americans and instructions to participants or caregivers, overseen by a dietician or individual of comparable expertise. Programs and presentations must be from a reputable and accredited source. Presentation can be one on one or in a group setting. Nutrition Education during congregate meals requires a presentation; Nutrition Education material shall be delivered to home delivered clients and counted. Only Agency provided material will be accepted for reimbursement.

Unit: Presentation on nutrition topic = 1 Unit

Supporting documentation: Article presented with date.

(C) Health Activities-Qualified: (previously Health Promotion/Disease Prevention)

Health programs that help older individuals “age in place” and with a higher quality of life. Activities may include those defined by OAA (section 102 (14)).

For example:

- routine health screenings,
- medication management,
- FROGS and other exercise groups led by certified trainers

Active licensed Registered Nurse or EMT are acceptable for health screenings.

LPN may be acceptable if they are employed through a hospital, health clinic, nursing home, etc.

Unit: One person per activity = 1 Unit

Supporting documentation: III B sign in sheet provided by NENAAA.

Demographic is required.

(D) Health Activities-Non-qualified: (previously Health Promotion/Disease Prevention)

Health programs that help older individuals “age in place” and with a higher quality of life. Activities may include those defined by OAA (section 102 (14)). For example:

- health education,
- exercise groups following a video, individual exercise, age-related diseases, and chronic disabling condition information,
- counseling regarding social services, and follow-up health services,
- educational services for individuals and their caregivers and or physical fitness, group exercise, music therapy, art therapy, and dance movement therapy (non-certified leader)

Unit: One person per Activity = 1 Unit

Supporting documentation: III B sign-in sheet provided by NENAAA.

(E) Technology & Equipment:

The provisions of goods to an older individual which will directly support the health and independence of the individual with an assessed need.

For example:

- Fans and heaters
- Briefs
- Eyeglasses
- Smoke detectors

- Medical equipment (Walkers, canes, etc.)

Service must be coordinated and distributed through the senior center and done by senior center staff, volunteers, or participants. No food and/or garden produce can be counted.

Unit: One item loaned out = 1 unit

Supporting Documentation: DME Assessment, Loan Agreement

Demographic is required.

(F) Social Activities:

The provision of activities which foster the social well-being of individuals through social activity interaction and the satisfying use of leisure time. Activities must be organized/planned by the senior center.

For example:

- Organized pool tournament
- Planned trip to a local point of interest (not to a casino)
- Planned book club
- Planned knitting circle

Spontaneous activities are not counted.

Unit: Activity

Supporting documentation: III B sign-in sheet provided by NENAAA.

(G) Senior Center Hours:

Hours of a multi-purpose senior center that is open to older individuals (center must offer services beyond meals). Counted by the hour Senior Center must be open to the public. Weekends, weather closings, and fundraising events will not count towards senior center hours. Reported senior center hours should mirror the advertised hours of operation, any deviation from that should be documented.

Unit: 1 hour = 1 unit

5. **SUPPORTIVE SERVICES TIMES.** The Contractor plans to be closed and not offer services on the following holidays.

New Year's Day, Presidents Day, Memorial Day, Independence Day, Labor Day, Veterans Day, Thanksgiving Day,

Day after Thanksgiving and Christmas Day

Services shall be made available between the hours of 7:30am to 3:30pm. The Contractor shall provide supportive services 5 days per week. Services are normally to be provided Monday through Friday; however, the Contractor may choose to provide services on Saturday or Sunday.

6. **DISCRIMINATION PROHIBITED.** The contractor shall not discriminate against any applicant to the program, or any employee who is employed in the performance of this contract, or against any applicant for such employment, because of age, color, national origin, religion, race, disability, marital status, or sex. This shall include, but not be limited to the following: employment, promotion, demotion, or transfer; recruitment or recruitment advertising; layoff or termination; rates of pay or other forms of compensation; and selection for training under

apprenticeship. The Contractor further agrees to insert a similar provision in all contracts for services allowed under this Contract.

7. CONTRIBUTION STANDARDS.

- a. Each eligible participant shall have an opportunity to voluntarily and anonymously contribute toward the cost of the provided supportive service.
- b. Contractor shall establish and implement procedures which will protect the privacy of the client's decision to contribute or not contribute toward the supportive service rendered.
- c. An eligible participant cannot be denied service(s) by the Contractor because of the participant's decision not to contribute for services rendered.
- d. All collected contributions shall be used to expand the service for which the contributions were given and to supplement funds received.
- e. There shall be a locked contribution box, placed away from the sign-in sheet which shall not be monitored for contributions, in order to assure the confidentiality of the donation.
- f. Participant contributions shall be counted by two volunteers or staff (manager excluded) and both individuals shall sign a form attesting to the correct amount. A copy of such signed documentation shall be kept on file.
- g. Bank deposits will be made daily.
- h. Daily sign in sheets provided by the Agency will identify participants, staff, volunteers, and guests.

8. REPORTING:

(A) Financial/III B Supportive Services Reports/logsheets: Accurate financial reports/logsheets, as required, must be filed with the Agency office *the 6th day of each month*. Only error free reports/logsheets will be accepted by the Agency no later than 10 A.M. on the 6th day of each month. If your reports/logsheets are received on or before the 5th at 5 pm, Agency staff will attempt to contact you for needed corrections. If Contractor is unavailable for corrections, no reimbursement will be disbursed that month. If Contractor cannot meet the report deadline, communication by the Contractor to the Agency may allow flexibility with deadline reimbursement.

(B) Filing Deadlines. When the 6th day of the month falls on a Saturday, reports are due the Friday before at or before 5:00 p.m. When the 6th day of the month falls on a Sunday, reports are due the Monday after at or before 10:00 A.M. Any contractor FAILING to meet the reporting deadlines, funding will be held until the following month or later if reports are not filed on time, incomplete or are inaccurate. September and June reports must be done within the deadlines or risks losing all funds for September and June due to the Federal and State fiscal year ending. Normal reimbursements occur after the Governing Board meeting of the Agency on the third Thursday of each month.

(C) Demographic forms should be filled out on supportive service participants as required (See definitions). Scan and email the original demographic form to the Agency when completed. The demographic form must be entirely completed prior to emailing to the Agency.

(D) Other Data. Contractor hereby agrees to supply Agency with any and all data and information as may be requested from time to time, and Contractor shall promptly and accurately submit written reports to Agency whenever requested to do so. All information shall be delivered via e-mail. Examples of data and information include but not limited to sign in sheets, supporting documentation of units provided, articles, materials handed out, meal verification forms, etc.

(E) Keeping of Records. Contractor hereby agrees to keep full and accurate sales, financial, procurement and other necessary records relating to all items covered by this Contract. Contractor shall keep all such records on file as established by Administration of Community Living, Internal Revenue Service, and the Secretary of State. Contractor shall permit authorized auditors and officials, upon request of the Agency, to have access to all such records for audit and review. In addition, authorized officials of Agency shall have the right to conduct on-site reviews of, but not limited to, all files pertinent to the annual evaluation, the III B Supportive Services Contract and service providers.

(F) False/Misleading Report. The submission of any false or misleading report by Contractor, shall result, at the option of the Agency, in the immediate cancellation of this Contract. Contractor shall be liable for any and all damage or loss caused by the submission of any false or misleading report.

(G) Misuse of Funds. Personal purchases, such as food items, office items or personal motel charges, made from the contractor's accounts, such as checking/savings account, debit/credit card, or contributions, shall at the option of the Agency, result in the immediate cancellation of this Contract.

Contractor's equipment purchased with federal and/or state funding, cannot be used by staff for personal use during paid and non-paid time.

(H) Gift Cards/Gift Certificates. Gift cards/gift certificates are not allowed as a Title III B expense.

8. ADMINISTRATIVE PROVISIONS.

(A) Rules and Regulations. Contractor shall comply with all of the rules, regulations and policies of the Federal Administration on Aging, Nebraska Department of Health and Human Services, Nebraska State Unit on Aging, Northeast Nebraska Area Agency on Aging, and any other federal or state requirements applicable.

(B) Equipment. All equipment purchased and or repaired with funds resulting from this Contract, shall remain the property of the contractor as long as the equipment is used to benefit the supportive service programs and programs authorized under this Contract. THIS EQUIPMENT CANNOT BE SOLD OR OTHERWISE DISPOSED OF WITHOUT OBTAINING THE PRIOR WRITTEN PERMISSION OF AGENCY. All Contractor's equipment purchased with federal/state funding cannot be used for personal use during paid and non-paid time.

(C) Senior Center Computer, Scanner and Internet. The Contractor shall have a working computer, scanner, and Internet at the Senior Center to provide the required information, receive communication from the Agency, and keep the confidential information at the Senior Center.

(D) Reduction of Funds. In the event that all of the program funds received by the Agency from the Nebraska Department of Health and Human Services State Unit on Aging are not allocated to the Agency as planned, Agency has the absolute right to reduce the program funds to Contractor accordingly.

(E) Attendance at Trainings. Contractor’s employees and center board members must attend training sessions as requested by Agency. These trainings are mandatory.

(F) III B Units of Service Reimbursement. Agency will only pay for defined III B Supportive Service units provided to qualifying individuals who are 60 years of age or older set forth by Older Americans Act (OAA).

(G) Term. The term of this Contract shall commence from July 1, 2023 through June 30, 2024.

(H) Daily Operation. The person responsible for the daily operation of the III B Supportive Services on behalf of the Contractor is:

Name: Patty Laska, Manager

Address: 3111 19th Street, Columbus NE 68601

Phone No.: (402-) - 563 -4444

Email address: plaska@columbusne.us

(I) Ceiling. Unless otherwise agreed or revised, this Contract shall constitute a ceiling for all participation of Agency in the approved cost.

(J) Identify Source of Funding. The Contractor will identify the source of funding for this Contract, including all material published that mentions the III B program. The following statement is to be used: “Partial funding for this program is provided by the Northeast Nebraska Area Agency on Aging”.

9. **CONTRIBUTIONS**. All III B service contributions shall be reported to the Agency as requested. Contributions are received only from those individuals who are 60 years of age or older, meeting eligibility set forth by OAA. See Page 4 #7 for Contribution Standards.

10. **REIMBURSEMENT TO CONTRACTOR**. The total reimbursement to the Contractor will be based on the Contractor’s number of Title III B units of services proposed in their budget in each service category multiplied by the Contractor’s reimbursement rate for each service (as shown in the table below). Agency agrees to provide a reimbursement amount not to exceed the total budgeted dollar amount in each category of III-B service (see table below) during the term of this Contract, unless prior written approval is obtained by the Contractor from the Agency. In addition, Contractor may receive contributions. All such contributions for services provided shall remain with Contractor. Should the Contractor’s anticipated program income be less than budgeted, the Agency will not be liable for any shortfall. Should the program income exceed the above figure, all excess will stay with the Contractor.

If funding is available, the Agency may reimburse for supportive services that exceed the budgeted number of units.

Title III-B Service	Total Number of Budgeted Units	Reimbursement Rate per Unit	Total Federal/State Funds Allocated
Information & Assistance	161	\$1.00	\$161.00
Nutrition Education	12	\$10.00	\$120.00
Health Activities Qualified	5,492	\$5.00	\$27,460.00
Health Activities Non-qualified	1,136	\$0.50	\$568.00
Technology & Equipment	208	\$6.00	\$1,248.00
Social Activities	1,096	\$10.00	\$10,960.00
Senior Center Hours	2,032	\$1.00	\$2,032.00
Total			\$42,549.00

11. **CONTRACT COMPLIANCE AND ENFORCEMENT.** It is the responsibility of the Agency staff to inform the Agency Executive Director of any Contractor’s failure to comply with the terms of this Contract. Upon being notified by staff, Executive Director shall implement the procedure below to assure compliance with the terms of this Contract:

(A) Notification of Non-Compliance of III B Supportive Services Contract. After it has been determined by Agency staff that the terms of this Contract are not being met, written notification of non-compliance shall be sent to the Contractor by the Agency. The notification shall set forth the portion of the Contract being violated.

(1) Repeated Non-Compliance. In the event any or all of the violations, as determined above, have not been corrected, the Executive Director of the Agency shall notify the contractor in writing that funding shall be withheld until such time Contractor is in compliance. In the event the violations have not been corrected, the Executive Director of the Agency shall proceed as set forth herein.

(2) Loss of funding. The Executive Director of the Area Agency will notify the Contractor, in writing, if non-compliance continues and a new fiscal year begins, funding for the entire non-compliance period shall be lost. Current non-compliance of Contract will be presented to the Agency Governing Board for further action, which could result in loss of future funding, as set forth by the Governing Board.

(3) Grievance Procedure. See Page 8 section 12 (A) #1 and #2

(B) Notification of Non-Compliance of Annual Monitoring Visit. According to the Agency’s Monitoring Policy, in the event of more than five recommendations, the Agency shall conduct an UNANNOUNCED follow-up. The unannounced follow-up monitoring will be conducted 30 days after the original monitoring and within 90 days of the original monitoring to allow the Contractor to come into compliance with any recommendations found during the monitoring. If recommendations are corrected no further action will be taken. If a recommendation(s) is deemed a critical finding, the Agency will notify the

Contractor verbally and in writing. The Agency will conduct an unannounced monitoring on the critical finding and all recommendations to ensure that the findings have been corrected. In the event the violations have not been corrected, the Executive Director of the Agency shall proceed as set forth herein.

(1) Repeated Non-Compliance. In the event any or all of the recommendations as determined above have not been corrected, the Executive Director of the Agency shall notify the Contractor in writing that funding shall be withheld until such time all recommendations have been corrected and a second UNANNOUNCED monitoring has been done by the Agency. If the recommendations have not been corrected after the second unannounced monitoring, the Executive Director of the Agency shall proceed as set forth herein. The Agency Governing Board will review and discuss the Contractor's repeated non-compliance of the annual monitoring and a decision determined.

(2) Notification of Board Decision. The Executive Director will notify the Contractor, in writing of the Board's decision. This could consist of the Contract being rendered null and void until such time violations are corrected and approved by the Agency Executive Director, Nutrition, Health and Services Coordinator and or Fiscal Officer. In the event non-compliance continues and a new fiscal year begins, funding for the entire non-compliance period shall be lost.

(3) Grievance Procedure. See section 12 (A); #1 and #2

(C) Non-compliance of Annual Monitoring Visit Response. In the event the Contractor has 5 or less recommendations, the Contractor has 30 days to respond and or show proof of compliance. If Contractor fails to meet this deadline a written reminder will be sent via e-mail. If the Contractor fails to respond in writing or show proof of compliance with 60 days of the monitoring visit, funds will be withheld until the Contractor is in compliance. If the fiscal year ends before compliance is met all funds will be lost.

12. GRIEVANCE PROCEDURE.

- (A) In the event that a dispute arises under this Contractor with the supportive service activity within the senior center on the part of Contractor, such dispute shall first be taken to the Nutrition, Health and Services Coordinator or Fiscal Officer of the Agency. If said dispute is not settled to the satisfaction of Contractor, Contractor may then take said dispute to the Executive Director of the Agency. In the event said dispute is still unsettled, Contractor shall have the right to:
1. Public Hearing. A public hearing may be requested by the Contractor if they have been notified in writing that they have not complied with the terms and conditions of this Contract and this Contract has been rendered null and void and payments have been terminated. Said request must be in written form and submitted to the Executive Director of the Agency within 5 days of notification of termination of this agreement. In the event the Compliance Board, as set forth herein, determines that the terms of this Contract were not violated, then those services provided by contractor after termination notice will be paid.
 2. Compliance Board. The Compliance Board shall consist of the Agency's Governing Board Executive Committee, two other members of the Agency's Governing Board, two Advisory Board members, and one senior center manager, who shall be appointed annually by the Agency Governing Board to serve on such Compliance Board. No

member of the Compliance Board may sit on said Board during a review if the violation involves a senior center or political subdivision they represent. The Chairperson of the Compliance Board shall appoint someone else to temporarily replace that Compliance Board member. In the event the Compliance Board chairperson shall be involved, then the replacement shall be selected by the Vice-Chairperson of the Compliance Board. The sole purpose of the Compliance Board shall be to review the terms of the Contract and determine if the Contractor is in violation of the terms and conditions of said Contract, when requested to do so. The recommendation(s) and or decision of the Compliance Board will be presented to and reviewed by the Agency's Governing Board, at their next regular meeting, whose decision shall be final.

13. **TERMINATIONS.** Either party may cancel during the term of this Contract for reasons other than a violation hereof; provided, however, that the terminating party shall give the other party 30 days prior written notice of any such termination. A copy of board minutes approving agreement termination shall be submitted with the written termination notice. Said 30 days' notice provision may be extended, *but not beyond June 30th*, in the event of a grievance procedure on the part of the Contractor.
14. **RETURN OF FUNDS.** Contractor may be required to reimburse Agency for any costs or expense, which may be disallowed as a result of an audit/monitoring by the Agency, federal/state government or agency thereof.
15. **EMERGENCY TERMINATION.** In those instances where the Contract violation threatens the health, welfare and safety of participants and/or staff of the Contractor, an emergency may be declared. After an emergency hearing and determination by the Agency Governing Board Executive Committee, this Contract may be declared null and void and all payments to Contractor terminated.
16. **INDEMNITY AND INSURANCE.**

(A) **Hold Harmless Agreement.** Contractor agrees to indemnify and hold Agency harmless from and against all claims, damages, loss and causes of action, of whatever nature, arising from any act, omission or negligence of contractor or contractor's agents or employees, to any person or to the property of any person, or arising from any accident, injury or damage whatsoever caused to any person or the property of any person occurring during the term of this agreement. This indemnity and hold harmless agreement shall include indemnity against all costs, expenses and liabilities in or in connection with any such claim or proceeding brought thereon and in defense thereof, including reasonable attorney's fees.

(B) **Insurance Required.** Contractor hereby agrees during the term hereof to maintain adequate general aggregate insurance, bonding and other insurance, which shall include fire and extended coverage insurance on all buildings, equipment and/or contents purchased in whole or in part by funds received from Agency, with reputable insurance companies approved by Agency as hereafter set forth and, upon request, to furnish agency with certificates of insurance properly executed by the insurance company evidencing such fact, giving 30 days prior written notice to Agency in the event of cancellation or material alteration of such coverage. The insurance coverage to be maintained by contractor shall include minimum insurance coverage of:

- a) General Aggregate insurance coverage of one million dollars
- b) Product liability coverage of one million dollars (for those centers that do meals at their facility)

- c) Per occurrence of one million dollar
- d) Bonding insurance coverage for a dollar amount approximate to the dollar amount on deposit in Contractor’s bank accounts.

The Northeast Nebraska Area Agency on Aging shall be named as additional insured on all such insurance policies.

17. **FAILURE TO PROVIDE SUPPORTIVE SERVICES.** In the event that the Contractor fails to provide III B supportive services to eligible participants, as agreed upon herein, the Agency may procure III B supportive services elsewhere, and charge or deduct from any amount payable to the Contractor the cost of such replacement services, plus any expenses incurred by the Agency in procuring such services.

18. **ASSIGNMENT OF AGREEMENT.** Contractor shall not assign this agreement, or any part thereof, nor subcontract any of Contractor’s duties or responsibilities hereunder, without obtaining the prior written consent of the Agency.

19. **MISCELLANEOUS PROVISIONS.**

(A) This Contract shall be governed by and construed under the laws of the State of Nebraska.

(B) This Contract shall insure to and be binding upon the parties hereto, their successors, assigns and transferees.

(C) The parties hereto agree that with respect to the performance of all terms, conditions and covenants of this Contract, time is of the essence.

(D) This Contract contains all agreements of the parties with respect to any matter mentioned herein. No prior Contract or understanding pertaining to any such matter shall be effective.

(E) This Contract may only be modified in writing and signed by the parties in interest at the time of such modification.

(F) All provisions of this Contract are subject to the Americans with Disabilities Act (20CFR 1601, 38 CFR 35).

(G) Designated III B supportive services alternate sites as indicated in paragraph “#2 Agreement” shall be:

Realife and Westport Apartments, which are independent living quarters

IN WITNESS WHEREOF, this Contract has been executed by duly authorized officers this _____ day of _____, 2023.

NORTHEAST NEBRASKA AREA AGENCY ON AGING (Agency)

By 
Chairman, Governing Board

ATTEST:

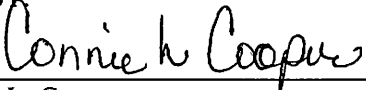
By 
Connie L. Cooper
Executive Director, NENAAA

City of Columbus
(Contractor)

By _____
Board Chairman/designated person

ATTEST:

By _____
Manager/Coordinator

III C NUTRITION CONTRACT FOR SENIOR CENTERS

This Contract is made and entered into this 1st day of July, 2023, by and between the Northeast Nebraska Area Agency on Aging, Norfolk, Nebraska, hereinafter called “Agency”, and City of Columbus hereinafter called “Contractor”.

1. **RECITALS.**

(A) Agency is a single purpose unit of government of the State of Nebraska authorized to provide services for persons 60 years of age or older within the Northeast Nebraska planning and service area.

(B) Agency has received a sub-award from the Nebraska Department of Health and Human Services State Unit on Aging, an agency of the State of Nebraska, to provide a nutrition service program to persons 60 years of age and older within the Northeast Nebraska planning and service area.

(C) Contractor is presently operating as a provider of food services and is capable and desirous of providing such food services as are hereinafter enumerated for and on behalf of the Agency.

NOW, THEREFORE, IT IS AGREED AS FOLLOWS:

2. **AGREEMENT.**

Contractor is hereby retained and appointed by Agency to purchase, prepare and serve to designated serving sites (see page 13 & 14 #31 G), meals as a part of the nutrition program for the elderly within the Northeast Nebraska planning and service area and any other area designated by Agency.

3. **ELIGIBLE:** who may participate in the Older Americans Act (OAA) nutrition program.

(A) Congregate meals:

1. Any person age 60 or over.
2. Under age 60 spouse accompanying individual that is 60 years or older.
3. Individuals providing volunteer services during meal hours.
4. Individuals with a disability, who resides at home with a person 60 years of age or older.
5. Individuals with a disability who reside in housing facilities occupied primarily by older persons at which congregate nutrition services are provided.

(B) Home Delivered meals:

With priorities given to:

1. Any person aged 60 or older who is frail, homebound by reason of illness or incapacitating disability, unable to attend a congregate meal; or
2. A spouse of #1 above, regardless of age or condition, may receive a home-delivered meal if the Area Agency on Aging criteria concludes that it is in the best interest of the homebound older person; or
3. A dependent individual with a disability that lives with a person 60 years of age or older that is eligible for a home-delivered meal.

With preferences given to:

1. Low-income older adults including low-income minority older adults.
2. Older adults with limited English proficiency.
3. Older adults residing in rural areas.

(C) To-Go Meals: (curbside, pick-up, drive-thru)

1. Individual must be 60 years or older or
2. Spouse accompanying individual 60 years or older or
3. Dependent with a disability lives with eligible individual or

4. Individual has a disability and living in senior housing.

(D) Volunteer Meals:

1. An individual under age 60, who provides volunteer services during meal hours, only on the day they volunteer their services (preparation of meal, set up of all tables, serving of meal, kitchen or dining room cleanup, meal delivery etc.) are eligible to receive a meal at the suggested contribution rate.

(E) Caregiver meals (home delivered meals):

1. The caregiver of a spouse of an eligible client, the caregiver may receive a home delivered meal for a suggested contribution. Home-Delivered Meal Assessment and demographic form must be filled out on spouse also.

4. **INELIGIBLE:** meals will not be funded by the OAA nutrition program, and the full cost of the meal shall be paid unless paid by another funding source.

(A) Congregate meals:

1. Any person under age 60.
2. Under age 60 spouse of a non-participating 60+ spouse.
3. Meals purchased by a business/entity, senior center, or another person, other than the meal participant, must pay the full cost of the meal and the meal is not an eligible meal (no one can “buy” a suggested contribution).

(B) Caregiver meals (home delivered meals):

1. If the caregiver is under 60, other than a spouse, the meal for the caregiver is for the full price of the meal.
2. An over 60 caregiver, other than the spouse, is not eligible for a home delivered meal and must pay the full cost of the meal.
3. Meals purchased by a business/entity, senior center, or another person, other than the meal participant, must pay the full cost of the meal and the meal is not an eligible meal (no one can “buy” a suggested contribution).

(C) Home-Delivered meals:

1. Any person under age 60 unless a spouse of eligible participant.
2. Any person that does not meet the criteria for home-delivered meals.

(D) To-Go meals:

1. Any person under age 60.

5. **CONTRIBUTION STANDARDS:**

1. Each eligible participant shall have an opportunity to voluntarily and anonymously contribute toward the cost of the provided meal service.
2. Contractor shall establish and implement procedures which will protect the privacy of the participant’s decision to contribute or not contribute toward the meal service rendered.
3. An eligible participant cannot be denied service(s) by the Contractor because of the participant’s decision not to contribute for services rendered.
4. All collected contributions shall be used to expand the service for which the contributions were given and to supplement funds received.
5. There shall be a locked contribution box, placed away from the sign-in sheet, which shall not be monitored for contributions, in order to assure the confidentiality of the donation.

6. Separate locked contribution boxes will be available for designated meals, such as congregate meal contributions and to-go meal contributions.
7. Participant contributions shall be counted by two volunteers, or staff (manager excluded), and both individuals shall sign a form attesting to the correct amount. A copy of such documentation shall be kept on file.
8. Bank deposits will be made daily.
9. Daily sign-in sheets or meal verification forms, provided by Agency, will identify participants, guests, volunteers and staff.
10. Non-eligible meal cost fees must be paid directly to Center staff or volunteers.

6. **MENUS AND MEAL PLANNING.**

(A) **Menu Planning.** Each meal served by Contractor must contain at least one-third of the current Dietary Reference Intakes and Dietary Guidelines.

Menu planning will be designed to include a variety of foods, color texture and contrast; avoiding excess fat, saturated fats and cholesterol; including foods with complex carbohydrates and fiber; avoiding excess refined carbohydrates (sugar); avoiding excessive sodium.

When planning the menu, keep in mind holidays, birthdays, lent, special events, evening meals, etc. to reduce the number of substitutions.

(B) **Menu Approval.** Contractors must submit menus to the Agency and the assigned Registered Dietician in a calendar format for approval on a quarterly basis. *The 3-month cycle of menus must consist of a minimum of one 20-day menu or a maximum of one 23-day menu to be repeated during the 3-month cycle.* Menus, in a calendar format listing portions of each food item, must be submitted to the Agency and the assigned Registered Dietician on or before the 1st day of June, September, December and March (one month prior to the start of the 3-month cycle). When the 1st day of the month falls on a Saturday, menus are due the Friday before. When the 1st day of the month falls on a Sunday, menus are due the following Monday. If Contractor submits the menus and or the revised menus so late that it does not allow for adequate time for menu review and approval, any meals that have not had menu approval will not be reimbursed. **All menus must be approved by the Registered Dietician prior to the meal being served to receive reimbursement.**

June 1st for July, August & September
 September 1st for October, November & December
 December 1st for January, February & March
 March 1st for April, May & June

1. The Registered Dietician approved menu must be the same menu listed in the newsletter and/or local newspaper.
2. Contractors will receive one written warning per fiscal year if Contractor does not serve the approved menu. After the written warning, all meals served without the Registered Dietician approved menu will not be reimbursed.

(C) **Food Substitution.** Each meal will be served as originally approved by the Registered Dietician. Food substitutions if any, must be of equal or higher nutritional value and may not reduce the nutritional content of the meal as approved; main entrée must be a similar food group, i.e. beef for beef, pork for pork, etc.

- Meal substitutions for the entire meal must be submitted to the Registered Dietician and the Agency prior to meal served.
- Protein substitutions must be submitted to the Agency prior to the meal served.

- The Agency will forward substitutions to Registered Dietician as needed/required.
- Other menu deviations will be written on a substitution form provided by the Agency and kept by Contractor for a period of three years.
- Review of the food substitutions form will be done by Agency during monitoring and throughout the fiscal year.
- Please see Substitution Guidance
- Excessive substitutions may result in the Contractor being charged for the Registered Dietician fee.

(D) Meal Pattern. The meal pattern shall satisfy the requirements of the provision of one-third of the current Dietary Reference Intakes. The following factors must be considered when menus are planned:

1. All foods must be specifically and precisely identified so that the nutritional content can be properly evaluated. For example, listing “fruit, juice or cookie” does not provide enough information to accurately determine the nutritional content of the menu.
2. Food items within the meat and meat alternatives, vegetable, and fruit groups shall be varied within the week and menu cycle. There should be minimal duplicates during any one-week period with the exception of bread, milk, and potatoes.
3. Food items identified as “fluff” salad or desserts will increase nutrient content but cannot count as a fruit or vegetable portion. “Frog-eyed” salad and nutrient dense desserts, such as pumpkin, fruit cocktail or applesauce bars or cakes, will count as a bread item but cannot be counted as a portion of fruit/vegetable.
4. Food items such as potato chips, tortilla chips, etc. can be a part of the meal, however cannot be counted as a portion of vegetable.
5. Highly processed proteins such as hot dogs, little smokies, etc. cannot be counted as a portion of protein.
6. Dried Fruits cannot be counted towards the 1 ½ cups of fruits and vegetables.
7. Menus are required to meet the daily nutrient requirements of 1/3 the Dietary Reference Intakes for the following nutrients:

- Protein – 22 grams per meal
- Fiber -10 grams per meal
- Vitamin A – 300 ug per meal
- Vitamin C – 30 mg per meal
- Folate – 133 mg per meal
- Calcium – 400 mg per meal
- Iron – 3 grams per meal
- Potassium – 1,566 per meal
- Sodium –1000 mg or less per meal

(a) Protein requirement will meet 1/3 of the Dietary Reference Intakes. Daily protein will be calculated from all food sources, meat, meat alternatives, beans, and dairy products.

(b) Fiber requirement will meet 1/3 of the Dietary Reference Intakes. Daily fiber requirements will be met by offering fresh fruits and vegetables, incorporating peelings, whole grain products such as brown rice, whole grain pasta, mixture of white/whole grain and or rice, whole or cracked wheat bread, and dried bean items. Serving of white bread should be kept to a minimum. See attachment A.

(c) Vitamin A and C requirement will meet 1/3 of the Dietary Reference Intakes. Vitamin A and C foods will be served daily – fresh or frozen items are preferred. Maintaining these nutrients will be best served with minimal cooking, via a steamer, or oven baked. If cooking in water, retain the water for sauces, gravies or part of the liquid when mashing potatoes. Vitamin A rich foods offered three (3) times per week, vitamin C offered daily from a fair source and three (3) times a week from a good source will assure nutrient content is met. Foods rich in vitamin A and C – see attachment A.

(d) Folate requirement will meet 1/3 of the Dietary Reference Intakes. Folate is a nutrient found in fortified breads, cereals, pastas, enriched rice, bean items, some vegetables, and home-made cereal/flour-based desserts (pies, cookies, crisps, rice crispy bars, etc). See attachment A.

(e) Calcium requirement will meet 1/3 of the Dietary Reference Intakes. Calcium is found in all dairy products, canned fish items with bones, green leafy vegetables, spinach, broccoli, fortified orange juice, tofu, and enriched soy milk. See attachment A.

(f) Iron requirement will meet 1/3 of the Dietary Reference Intakes. Iron is found in all meat items, beans, dried peas, canned spinach, sweet potatoes, mixed vegetables with lima beans, peaches, prune and tomato juice, walnuts, molasses, and enriched pasta and bread. See attachment A.

(g) Potassium requirement will meet 1/3 of the Dietary Reference Intakes. Potassium is found in fresh fruits and vegetables. Potassium is found in the peelings of foods, therefore, every effort should be made to serve foods incorporating the peeling (baked potato, potato wedges with skin, mashed, hashed, or French fried potatoes with peelings). Refrain from using boxed, instant or frozen potatoes. See attachment A.

(h) Sodium requirement can be reduced by using fresh and frozen vegetables. Limit canned foods, convenience entrees, mixes, sauces, and baked items that offer few nutrients other than fat and sugar. Cooking with salt should be minimal. See Attachment A.

Nutrient content must be met for each menu but the following minimums must be served:

- Main entrée shall be no less than 3 ounces of edible protein.
- 1 ½ cups of fruit and or vegetables.
- Two 1 oz servings of bread items –this can be met in the following ways:
 - 2 oz of high fiber bread
 - ½ cup of bread alternatives (pasta, oatmeal and or rice) along with 1 oz of bread
 - fiber dense desserts along with 1 oz bread
 - sandwich item that contains 2 slices of bread or 1 bun
- 8 oz of milk.
- 1 tsp margarine

Accompaniments will need to be added to the menu for appeal and participant satisfaction, e.g., coffee, tea, water, condiments, additional margarine, ketchup, mustard, sour cream, mayonnaise, tartar sauce, salad dressing, etc.

7. **PERFORMANCE ACCOUNTABILITY.** Emphasis on accountability and performance measures to demonstrate service and or program efficiency, effectiveness, and quality. Contractors that repeatedly are in non-compliance of performance accountability (gross costs, minutes per meal, quality of product, etc.) may jeopardize their opportunity to receive reimbursement increases and or additional funding.
8. **PORTION CONTROL.** Prevents not having enough food at serving time, eliminates waste and assures the recommended quantity to each participant. Any Agency staff member may check portions when they are at the senior center on any given day. If the appropriate portion does not meet all recommendations each contractor will receive one written warning per fiscal year. After the written warning, if portions are not met, funding will not be provided for all meals served on that particular day.
9. **FOOD QUALITY.** In the context of food production, quality refers to a product's taste, texture, appearance, color, variety, nutritional value and overall level of excellence. To achieve an excellent finished product each time the following should be adhered to:
 - Do not overcook foods. Prepare and cook foods to enhance flavor and to maintain color and texture.
 - Prepare different types of food for each meal (Example: chicken, ham, roast beef, etc.).
 - Use different methods of food preparation (Example: baking, boiling, steaming, etc.).
 - Use a variety of textures (Example: mashed potatoes and carrot sticks).
 - Two colorful food items will be used in each meal (Example: green beans and peaches).
 - Garnishes can and should be used to add color and to “dress up” the food item (Example: whip topping on apple crisp; nutmeg on custards, etc.).
 - Serve fruits, custards, puddings, etc. chilled.

- Use herbs and spices to enhance flavors. (Example: nutmeg, garlic or onion powder, parsley flakes, etc.)
- Use only good quality foods.
- Serve hot foods at 135 degrees F or above and cold foods at 41 degrees F or below.

The minimum standard of food to be used by the Contractor will include:

- Canned fruit and vegetable - USDA Grade A. No home canned items.
- Fresh fruit and vegetables - No. 1 quality.
- Poultry - USDA Grade A or better.
- Beef - USDA Choice or better. Ground beef should be no more than 20% fat content.
- Pork - USDA No 1. or better.
- Eggs and Dairy Products - USDA Grade A or better. Eggs can be purchased from licensed farm (license # must be on file at the center).
- Salt - iodized.
- Items from a Food Pantry must not have dented cans, must have labels, and must not be outdated.

(F) Serving Times. The Contractor plans to be closed and not serve on the following holidays:

New Year's Day, Presidents Day, Memorial Day, Independence Day, Labor Day,

Veteran's Day, Thanksgiving Day, Day after Thanksgiving and Christmas Day.

Meals shall be made available between the hours of 12:00pm and 12:30pm. Contractor is encouraged to serve a breakfast, brunch, or evening meal. Permit all participants to eat a leisurely meal.

The Contractor shall serve meals a minimum of five days per week unless approved by Agency. Meals are normally to be served Monday through Friday, however, the Contractor may choose to serve meals on Saturday or Sunday as one of the five days required.

(G) Weather Closing Policy – All Contractors must establish a weather closing policy, keeping in mind the home delivered meal participants if it is to be more than one day. Policy shall state the protocol for closing and a procedure for providing home delivered meals if Contractor is closed for more than one day. School closing is not a legitimate reason for Contractor to close.

(H) Emergency Meal Policy. If meals cannot be provided, other than due to bad weather, the Agency must be notified immediately, and Contractor follow plan of action set forth in Contractor's written emergency meal policy. In the event contractor does not provide meal service during this time, please see page 13, #29, Failure to Provide Meals. At a minimum, the written emergency meal contract must list the name and contact information of the emergency meal provider, the meal requirements, transportation of meals, cost, date of contract and reviewed annually by all parties. A copy of the Emergency Meal Policy is to be submitted to the Agency.

(I) Catered Meal Contract. All Contractors, whose meals are catered from a restaurant, hospital, nursing care facility or senior center must have a Contract, provided by the Agency, with the catered facility. A copy of the signed contract must submitted to the Agency prior to the Contractor receiving funds.

(J) Home-Delivered Meals.

1. Contractors which provide home delivered meals must protect the health and safety of the participants, ensuring that the hot food is 135 degrees F or hotter, and the cold food is 41 degrees F or colder when delivered to the participants. To assure quality temperature, all food must be placed in tested temperature control containers, and then placed in an insulated container for delivery. No sacks or boxes can be used to deliver the meal. If a route takes longer than 45 minutes, the route needs to be shortened with only a few meals sent out at a time or divided into multiple routes.

2. On a quarterly basis, an extra meal must be sent, alternating routes, so temperature checks can be taken of each food before and at the end of the home delivered route. Records of these temperature checks must be recorded and kept on file on the temp form. Temperatures must stay out of the temperature danger zone of 41 degrees to 135 degrees (see page 7, Sanitation and Safety, # E).
2. Participants can receive a home delivered meal on a permanent basis based on eligibility, please refer to Page 1, #3B. A home-delivered meal assessment must be done by Contractor staff to determine eligibility for home delivered meals before meal service starts. The participant receiving a home delivered meal must have his/her status reviewed annually and shall receive such meal as set forth in the policy adopted by the Agency. Any person receiving a home delivered meal shall have a written assessment kept on file at the office of the Contractor.
3. A temporary home-delivered meal may be provided for *14 consecutive days or less* without an assessment being completed by the Contractor. A temporary home-delivered meal tracking form, provided by the Area Agency, must be completed by Contractor and kept on file. If meals go beyond the 14 days, Contractor must get a demographic and home delivered meal assessment form filled out by the participant. *Please refer to the Agency's Home Delivered Meal Policy.*
5. Meals will be delivered to the meal participant's home. When a client is not home to receive their meal, the delivery personnel will not leave the meal at the residence. The program has a responsibility to deliver the meal in a safe manner, leaving the food unattended for an undetermined amount of time is not safe.
6. Please refer to the Northeast Nebraska Area Agency on Aging Policy for Home Delivered Meals.

11. CONGREGATE MEAL SITES SHALL:

- A) include procedures for collecting feedback from participants about services received.
- B) ensure the service of a meal to a participant who has failed to make a reservation, when food is available. Eligible participants shall be assured of a meal before ineligible participants/paid staff.
- C) have paid staff/volunteer physically on-site during mealtime.

12. SANITATION AND SAFETY. Compliance with federal, state, and local fire, health sanitation, safety and building codes, regulations, licensure requirements, and other provisions relating to the public health, safety, and welfare applicable to each nutrition site used in the nutrition program is required in all stages of food service operations.

- A). Specifically, regarding food and food service, the Contractor must comply with the Nebraska Department of Environment and Energy, and other applicable provision of State and local laws regarding safe and sanitary handling of food, storage, preparation, service, equipment, and utensils, and on surfaces which prior to use, have been cleaned, rinsed, and sanitized to prevent cross contamination. **Contractor must send the Agency a copy of their Food Establishment Evaluation within 30 days of said inspection and their written plan of action.** Any critical Food Establishment Evaluation findings will be followed up by the Agency's Nutrition Department.
- B). Meal site must maintain prep/cooking, storage, dining and restroom areas to be clean and free from pests and debris. Professional exterminators must be utilized on a regular basis.
- C). Foods used in the home-delivered nutrition program must be selected, stored, prepared, packaged, and delivered in a manner to assure maximum nutrient content of food value and to improve or increase digestibility of the food.
- D). Foods must be properly stored with foods off the floor. A thermometer in the store room to ensure proper temperature of 50–70-degree F. Maintain refrigerator temperature of 36 degrees F to 40 degrees F. Freezer temperature must be 0 degrees or below. Check and record these temperatures on Agency provided form a minimum of two times daily, once at the beginning of the shift and again at the end of the shift.

- E). Hot foods must be served at 135 degrees F or above and cold foods served 41 degrees F or below. Foods can only be allowed to remain between 41 degrees and 135 degrees for one hour or less, including preparation, serving and holding.
- F). On a daily basis, temperature checks must be taken with a food thermometer before serving. Records of these temperature checks must be on file on Agency form.
- G). The transport equipment, packaging materials, and procedures used by the Contractor to deliver meals to the home for immediate consumption must be able to maintain hot food temperatures at or above 135 degrees F and cold temperatures at or below 41 degrees F. In order to prevent food from dropping into the danger zone during transport, hot foods need to go out at 180 degrees or higher and cold foods at 36 degrees or lower.
- H). Leftovers are not encouraged and should be held to a minimum. For catered operations, all leftover food must be disposed of at the nutrition site. For on-site preparation facilities, leftover food must be removed from the steam table immediately following serving and be properly refrigerated or placed in the freezer. If refrigerated, leftovers must be used within 3 days. All leftovers must be reheated to 165 degrees F and used only as an extra helping or choice. All foods prepared the day before must be cooked to its proper temperature stage prior to refrigerating. These foods will be considered leftovers and must be reheated to 165 degrees F.
- I). To protect nutrition service participants from food borne illness, congregate meal participants are prohibited from taking any potentially hazardous food items home. A potentially hazardous food is any food that consists in whole or in a part of milk or milk products, eggs, meat, poultry, fish, or other ingredients, including synthetic ingredients in a form capable or supporting rapid and progressive growth of infectious or toxigenic microorganisms. Foods which may be removed from the center include cake, cookies, bread, and fresh fruit, such as apple, orange, pear or banana etc.
- J). Bibbed aprons must be worn by all food preparation staff and volunteers.
- K). Hands must be properly washed prior to disposable glove use. Glove usage should be in meal prep, serving line and set up of home delivered meals.
- L). Sanitizing solution must be used on all food preparation surfaces prior, during and after food preparation. Sanitizing solution must be changed a minimum of every 4 hours or when solution becomes dirty. Frequent testing must be done on the solution with test strips appropriate for the sanitizing agent used.
- M). Effective procedures for dish washing and sanitizing in a three-compartment sink must be posted and followed. Written procedures for cleaning equipment and the work area must be on file and followed consistently.
- N). All hair shall be covered by hairnets/caps with no hair showing while working in kitchen. Front, sides, top, and neckline hair that is collar length or longer must be covered by hair restraints during serving.

14. MEAL SITES SHALL POST SIGNAGE SHOWING:

- a) Where exits are located
- b) Evacuation plan map with written explanation of evacuation
- c) Dining menus
- d) Cost sharing information for full price/suggested contribution
- e) Signage stating clients cannot take home potentially hazardous foods
- f) Emergency numbers

15. REPORTING FOODBORNE ILLNESS: If food poisoning is suspected as a cause of illness from a meal provided by a Contractor of the Agency, the procedure below must be followed:

1. Contact the Northeast Nebraska Area Agency on Aging Nutrition, Health and Services Coordinator, Fiscal Officer or the Executive Director immediately by calling 1-800-672-8368. The Agency will contact the Nebraska Department of Health and the State Unit on Aging.
2. Have the individual who has become ill contact a doctor immediately for diagnosis. Ask the individual to have the doctor contact the contractor if there is a possibility of food poisoning.

3. Contact each person who ate at the nutrition site that day (congregate and home delivered) and check for illness. This contact may be made by phone or in person. If individuals are ill, Contractor must follow step #2.
4. Keep the Nutrition, Health and Services Coordinator, Fiscal Officer or Executive Director notified.

16. **NUTRITION SERVICES INCENTIVE PROGRAM (NSIP)**. The NSIP per meal rate of reimbursement is determined by the USDA and may fluctuate throughout the year. NSIP monies are passed through to the Contractor monthly with no funds being retained by the Agency for this service. NSIP funds are only available for the purchase of food. NSIP funds shall not be used to meet cost sharing or as matching funds for any other federal program. NSIP funds shall never be used to cover meal transportation costs, staff salaries, location costs, etc.

17. **PRODUCTION STAFFING GUIDELINES**. As approved by the Northeast Nebraska Area Agency on Aging Governing Board on March 16, 2006, the maximum staffing guidelines to be used by each Contractor with on-site meals cannot exceed: **12 MAXIMUM KITCHEN LABOR MINUTES PER MEAL**. Continued high kitchen labor minutes per meal may result in the Contractor being notified of non-compliance with the Nutrition Contract (See Contract Compliance & Enforcement, #23 A). Exceptions to non-compliance may be made at the discretion of the Agency Nutrition Department, Fiscal Officer, and or the Agency's Executive Director. Kitchen labor minutes per meal includes all paid kitchen staff from the beginning of preparation of the meal through cleanup of dishes, kitchen, and kitchen equipment. Kitchen labor minutes per meal does not include personnel leave time.

18. **DISCRIMINATION PROHIBITED**. The Contractor shall not discriminate against any applicant to the program, or any employee who is employed in the performance of this Contract, or against any applicant for such employment, because of age, color, national origin, religion, race, disability, marital status or sex. This shall include, but not be limited to the following: employment, promotion, demotion, or transfer; recruitment or recruitment advertising; layoff or termination; rates of pay or other forms of compensation; and selection for training under apprenticeship. The Contractor further agrees to insert a similar provision in all subcontracts for services allowed under this Contract.

19. **REPORTING**.

(A) **Financial/III C Nutrition Reports/logsheets**: Accurate financial reports/logsheets, as required, must be filed with the Agency office *the 6th day of each month*. Only *error free reports/logsheets* will be accepted by the Agency no later than 10 A.M. on the 6th day of each month. If your reports/logsheets are received on or before the 5th at 5 pm, Agency staff will attempt to contact you for needed corrections. If Contractor is unavailable for corrections, no reimbursement will be disbursed that month. If Contractor cannot meet the report/logsheet deadline, communication by the Contractor to the Agency may allow flexibility with deadline and reimbursement.

(B) **Filing Deadlines**. When the 6th day of the month falls on a Saturday, reports are due the Friday before at or before 5:00 P.M. When the 6th day of the month falls on a Sunday, reports are due the Monday after at or before 10:00 A.M. Any contractor FAILING to meet the reporting deadlines, funding will be held until the following month or later if reports are not filed on time, incomplete or are inaccurate. September and June reports must be done within the deadlines or risks losing all funds for September and June due to the Federal and State fiscal year ending. Normal reimbursements occur after the Governing Board meeting of the Agency on the third Thursday of each month.

(C) **Demographic forms** should be filled out on all congregate and home-delivered meal participants after they have received 3 meals. Scan and email the original demographic form to the Agency when completed. The demographic form must be entirely completed prior to emailing the Agency.

(D) **Other Data**. Contractor hereby agrees to supply Agency with any and all data and information as may be requested from time to time, and Contractor shall promptly and accurately submit written reports to Agency whenever requested to do so. All information shall be delivered via e-mail. Examples of data and information include but not limited to sign in sheets, supporting documentation of units provided, articles, materials handed out, meal verification forms, etc.

(E) **Keeping of Records**. Contractor hereby agrees to keep full and accurate sales, financial, procurement and other necessary records relating to all items covered by this Contract. Contractor shall keep all such records on file as established by Administration for Community Living, Internal Revenue Service, and the Secretary of State. Contractor

shall permit authorized auditors and officials, upon request of Agency, to have access to all such records for audit and review. In addition, authorized officials of Agency shall have the right to conduct on-site reviews of, but not limited to, all files pertinent to the annual evaluation, the Nutrition Contract, the food service, transportation, and vendors.

(F) False/Misleading Report. The submission of any false or misleading report by Contractor shall result, at the option of the Agency, in the immediate cancellation of this Contract. Contractor shall be liable for any and all damages or loss caused by the submission of any false or misleading report.

(G) Misuse of Funds/Equipment. Personal purchases, such as food items, office items or personal motel charges, made from the Contractor's accounts, such as checking/savings account, debit/credit card, or contributions, shall result at the option of the Agency, in the immediate cancellation of this Contract.

Contractor's equipment, purchased with federal/state funding, cannot be used by staff for personal use during paid and non-paid time.

(H) Gift Cards/Gift Certificates. Gift cards/gift certificates are not allowed as a Title III C expense.

20. ADMINISTRATIVE PROVISIONS.

(A). Rules and Regulations. Contractor shall comply with all rules, regulations and policies of the Federal Administration for Community Living, Nebraska Department of Health and Human Services, Nebraska State Unit on Aging, Northeast Nebraska Area Agency on Aging, and any other federal or state requirements applicable.

(B). Equipment. All equipment purchased and or repaired with funds resulting from this Contract, shall remain the property of the Contractor as long as the equipment is used to benefit the local senior citizens' program and programs authorized under this Contract. **THIS EQUIPMENT CANNOT BE SOLD OR OTHERWISE DISPOSED OF WITHOUT OBTAINING THE PRIOR WRITTEN PERMISSION OF THE AGENCY.** All Contractor equipment, purchased with federal/state funding, cannot be used by staff for personal use during paid and non-paid time.

(C). Senior Center Computer, Scanner, and Internet. The Contractor shall have a working computer, scanner, and internet at the senior center to provide the required information, receive communication from the Agency, and keep the confidential information at the senior center.

(D). Reduction of Funds. In the event that all of the program funds received by the Agency from the Nebraska Department of Health and Human Services, Nebraska State Unit on Aging and/or NSIP are not allocated to the Agency as planned, Agency has the absolute right to reduce the program funds to Contractor accordingly.

(E). Attendance at Trainings. All center managers, center board members, employees, and cooks must attend training sessions as requested by Agency. The trainings are mandatory.

(F). ServSafe. The Contractor's head cook, and manager or person who supervises the kitchen shall be ServSafe certified. These certificates shall be posted in the center and kept current.

(G). Meal Reimbursement. Agency will only pay for meals meeting standards and requirements set forth in this III C Nutrition Contract, served to eligible individuals.

(H). Term. The term of this Contract shall commence from July 1, 2023 through June 30, 2024.

(I). Daily Operation. Person responsible for the daily operation of the nutrition site on behalf of the Contract is:

Name: Patty Laska, Manager

Address: 3111 19th Street

Columbus NE 68601

Phone: (402) - 563-4444

Email address: plaska@columbusne.us

(J). Ceiling. Unless otherwise agreed or revised, this Contract shall constitute a ceiling for all participation of Agency in the approved cost.

(K). Identify Source of Funding. The Contractor will identify the source of funding for this Contract, including all material published that mentions the meal program. The following statement is to be used: “Partial funding for this program is provided by the Northeast Nebraska Area Agency on Aging”.

21. **MEAL CONTRIBUTIONS**. All meal contributions shall be reported to the Agency as requested. Meal contributions are received only from those individuals who are 60 years of age or older, the spouse of an eligible participating individual 60 years or older, and all other individuals meeting eligibility set forth by OAA and NSIP. All other ineligible individuals must pay full cost for the meal unless paid by another funding source. See page 2 #6 for Contribution Standards.

22. **REIMBURSEMENT TO CONTRACTOR**. The reimbursement rate will be based on the contractor’s federal/state dollar allotment and the number of Title IIIC meals proposed in their budget, but not to exceed **\$35,772** per Title IIIC congregate meal or **\$29,844** per Title IIIC home-delivered meal. In addition, Contractor will receive NSIP reimbursement and daily contributions. All such daily contributions and NSIP reimbursement for meals served shall remain with Contractor.

Agency agrees to provide a base amount of **\$2.40** per meal for **14,905** congregate meals, not to exceed **\$35,772** and **\$2.90** per meal for **10,291** home-delivered meals, not to exceed **\$29,844** during the term of this Contract, unless prior written approval is obtained by the Contractor from the Agency. In addition, Contractor shall receive NSIP reimbursement for each meal served to a qualifying individual. Total anticipated funds received by Contractor for each meal is NSIP + **\$2.40** from state and/or federal funding and contributions from the meal for congregate meals and NSIP + **\$2.90** from state and/or federal funding and contributions for home-delivered meals. Should the Contractor’s anticipated program income be less than budgeted, the Agency will not be liable for any shortfall. Should the program income exceed the above figure, all excess will stay with the Contractor. If funding is available, Agency may reimburse for meals that exceed the budgeted number of meals.

23. **CONTRACT COMPLIANCE AND ENFORCEMENT**. It is the responsibility of the Agency staff to inform the Agency Executive Director of any Contractor’s failure to comply with the terms of this Contract. Upon being notified by staff, Executive Director shall implement the procedure below to assure compliance with the terms of this Contract:

(A) Notification of Non-Compliance of Nutrition Contract. After it has been determined by Agency staff that the terms of this Contract are repeatedly not being met, written notification of non-compliance shall be sent to the Contractor by the Agency. The notification shall set forth the portion of the Contract being violated.

(1) Repeated Non-Compliance. In the event any or all of the violations, as determined above, have not been corrected, the Executive Director of the Agency shall notify the Contractor in writing that funding shall be withheld until such time Contractor is in compliance. In the event the violations have not been corrected, the Executive Director of the Agency shall proceed as set forth herein.

(2) Loss of funding. The Executive Director of the Agency will notify the Contractor, in writing, if non-compliance continues and a new fiscal year begins, funding for the entire non-compliance period shall be lost. Current non-compliance of Contract will be presented to the Agency Governing Board for further action, which could result in loss of future funding, as set forth by the Governing Board.

(3) Grievance Procedure. See page 12, section 24.

(B) Notification of Non-Compliance of Annual Monitoring Visit. According to the Agency's Monitoring Policy, in the event of more than five recommendations, the Agency shall conduct an unannounced follow-up. The unannounced follow-up monitoring will be conducted 30 days after the original monitoring and within 90 days of the original monitoring to allow the Contractor to come into compliance with any recommendations found during the monitoring. If recommendations are corrected no further action will be taken. If a recommendation(s) is deemed a critical finding, the Agency will notify the Contractor verbally and in writing. The Agency will conduct an unannounced monitoring on the critical finding and all recommendations to ensure that the findings have been corrected. In the event the violations have not been corrected, the Executive Director of the Agency shall proceed as set forth herein.

(1). Repeated Non-Compliance. In the event any or all of the recommendations as determined above have not been corrected, the Executive Director of the Agency shall notify the Contractor in writing that funding shall be withheld until such time all recommendations have been corrected and a second unannounced monitoring has been done by the Agency. If the recommendations have not been corrected after the second unannounced monitoring, the Executive Director of the Agency shall proceed as set forth herein. The Agency Governing Board will review and discuss the Contractor's repeated non-compliance of the annual monitoring and a decision determined.

(2) Notification of Board Decision. The Executive Director will notify Contractor in writing of the Board's decision. This could consist of the Contract being rendered null and void until such time violations are corrected and approved by the Agency Executive Director, Nutrition, Health and Services Coordinator and or Fiscal Officer. In the event non-compliance continues and a new fiscal year begins, funding for the entire non-compliance period shall be lost.

(3) Grievance Procedure. See page 12, section 24.

(C) Non-compliance of Annual Monitoring Visit Response. In the event the Contractor has five or less recommendations, the Contractor has 30 days to respond and or show proof of compliance. If Contractor fails to meet this deadline a written reminder will be sent via e-mail. If the Contractor fails to respond in writing or show proof of compliance within 60 days of the monitoring visit, funds will be withheld until the Contractor is in compliance. If the fiscal year ends before compliance is met all funds will be lost.

24. GRIEVANCE PROCEDURE.

- (A) In the event that a dispute arises under this Contract or with the nutrition activity within the senior center on the part of Contractor, such dispute shall first be taken to the Nutrition and Services Coordinator and or Fiscal Officer of the Agency. If said dispute is not settled to the satisfaction of Contractor, Contractor may then take said dispute to the Executive Director of the Agency. In the event said dispute is still unsettled, Contractor shall have the right to:
1. Public Hearing. A public hearing may be requested by the Contractor if they have been notified in writing that they have not complied with the terms and conditions of this Contract and this Contract has been rendered null and void and payments have been terminated. Said request must be in written form and submitted to the Executive Director of the Agency within 5 days of notification of termination of this Contract. In the event the Compliance Board, as set forth herein, determines that the terms of this Contract were not violated, then those services provided by Contractor after termination notice will be paid.
 2. Compliance Board. The Compliance Board shall consist of the Agency's Governing Board Executive Committee, two other members of the Agency's Governing Board, two Advisory Board members, and one senior center manager, who shall be appointed annually by the Agency Governing Board to serve on such Compliance Board. No member of the Compliance Board may sit on said Board during a review if the violation involves a center or

political subdivision they represent. The Chairperson of the Compliance Board shall appoint someone else to temporarily replace that Compliance Board member. In the event the Compliance Board chairperson shall be involved, then the replacement shall be selected by the Vice-Chairperson of the Compliance Board. The sole purpose of the Compliance Board shall be to review the terms of the Contract and determine if the Contractor is in violation of the terms and conditions of said Contract, when requested to do so. The recommendation(s) and or decision of the Compliance Board will be presented to and reviewed by the Agency's Governing Board, at their next regular meeting, whose decision shall be final.

25. **TERMINATIONS.** Either party may cancel this Contract during the term of this Contract, for reasons other than a violation hereof; provided, however, that the terminating party shall give the other party 30 days prior written notice of any such termination. Said 30 days' notice provision may be extended, *but not beyond June 30th*, in the event of a grievance procedure on the part of the Contractor.

26. **RETURN OF FUNDS.** Contractor may be required to reimburse Agency for any costs or expense, which may be disallowed as a result of an audit/monitoring by the Agency, federal/state government or agency thereof.

27. **EMERGENCY TERMINATION.** In those instances where the Contract violation threatens the health, welfare, and safety of participants and/or staff of the Contractor, an emergency may be declared. After an emergency hearing and determination by the Agency Governing Board Executive Committee, this Contract may be declared null and void and all payments to Contractor terminated.

28. **INDEMNITY AND INSURANCE.**

(A) **Hold Harmless Agreement.** Contractor agrees to indemnify and hold Agency harmless from and against all claims, damages, loss and causes of action, of whatever nature, arising from any act, omission or negligence of Contractor or Contractor's agents or employees, to any person or to the property of any person, or arising from any accident, injury or damage whatsoever caused to any person or the property of any person occurring during the term of this Contract. This indemnity and hold harmless agreement shall include indemnity against all costs, expenses and liabilities in or in connection with any such claim or proceeding brought thereon and in defense thereof, including reasonable attorney's fees.

(B) **Insurance Required.** Contractor hereby agrees during the term hereof to maintain adequate public liability, product liability, bond insurance and other insurance deemed necessary by the Northeast Nebraska Area Agency on Aging, which shall include but not limited to fire and extended coverage insurance on all buildings, equipment and/or contents purchased in whole or in part by funds received from Agency, with reputable insurance companies approved by Agency as hereafter set forth and, upon request, to furnish agency with certificates of insurance properly executed by the insurance company evidencing such fact, giving 30 days prior written notice to Agency in the event of cancellation or material alteration of such coverage. The insurance coverage to be maintained by Contractor shall include minimum insurance coverage of:

- a. General Aggregate insurance coverage of two million dollars
- b. Product Liability insurance coverage of two million dollars
- c. Per occurrence of one million dollars
- d. Bonding insurance coverage for a dollar amount approximate to the dollar amount on deposit in Contractor's bank accounts

The Northeast Nebraska Area Agency on Aging shall be named as additional insured on all such insurance policies.

29. **FAILURE TO PROVIDE MEALS.** In the event that the Contractor fails to provide a meal or meals to the participants, as agreed upon herein, the Agency may procure a meal or meals or other food elsewhere, and charge or deduct from any amount payable to the Contractor the cost of such replacement meal or meals or other food, plus any expenses incurred by the Agency in procuring such replacement meal or meals or other food.

30. **ASSIGNMENT OF CONTRACT.** Contractor shall not assign this Contract, or any part thereof, nor subcontract any of Contractor's duties or responsibilities hereunder, without obtaining the prior written consent of the Agency.

31. MISCELLANEOUS PROVISIONS.

- (A) This Contract shall be governed by and construed under the laws of the State of Nebraska.
- (B) This Contract shall insure to and be binding upon the parties hereto, their successors, assigns and transferees.
- (C) The parties hereto agree that with respect to the performance of all terms, conditions and covenants of this Contract, time is of the essence.
- (D) This Contract contains all agreements of the parties with respect to any matter mentioned herein. No prior Contract or understanding pertaining to any such matter shall be effective.
- (E) This Contract may only be modified in writing and signed by the parties in interest at the time of such modification.
- (F) All provisions of this Contract are subject to the Americans with Disabilities Act (20CFR 1601, 38 CFR 35).
- (G) Designated serving sites as indicated on page 1 #2 AGREEMENT shall be: _____
Realife and Westport Apartments, which are independent living quarters.

IN WITNESS WHEREOF, this Contract has been executed by duly authorized officers this _____ day
 Of _____ 2023.

NORTHEAST NEBRASKA AREA AGENCY ON AGING (Agency)

By *Dennis Hunt*
 Chairman, Governing Board, NENAAA

ATTEST:

By *Connie L. Cooper*
 Connie L. Cooper
 Executive Director, NENAAA

 City of Columbus
 (Contractor)

By _____
 Contract President/Chairman
 Mayor

ATTEST:

By _____
 Contract Manager/Coordinator

Title III E Family Caregiver Support Contract

This Contract is made and entered into this 1st day of July, 2023 by and between the Northeast Nebraska Area Agency on Aging, Norfolk, Nebraska, hereinafter called “Agency” and City of Columbus hereinafter called “Contractor”.

I. General Terms

A. Provision of Service:

Caregiver Support Group: A service that facilitates a peer-to-peer support group. Caregivers will discuss their common experiences and concerns and develop a mutual support system. It may include instruction to improve knowledge and performance of specific skills relating to their caregiving roles and responsibilities. Skills may include activities related to health, nutrition, and financial management, providing personal care, and communicating with health care providers and other family members. It must be conducted in-person and be provided in group settings.

Caregiver Information & Assistance: Provided to a caregiver at the direction of the caregiver:

- Provides the individuals with current information on opportunities and services available to the individuals within their communities, including information relating to assistive technology.
- Assesses the problems and capacities of the individuals.
- Links the individuals to the opportunities and services that are available and
- To the maximum extent practicable, ensure that the individuals receive the services needed by the individuals and are aware of the opportunities available to the individuals by establishing adequate follow-up procedures.

B. Service Area: Planning and service area counties.

C. Term: Shall be for a period of one year commencing July1, 2023 and ending June 30, 2024.

D. Reimbursement to Contractor:

- a. Caregiver Support Group: \$225 per unit for 12 units budgeted which includes 12 monthly caregiver support group meetings, for a total allocation of \$2,700. Supporting documentation is the sign-in sheet.

A unit will be reimbursed if there are no participants at the support group with evidence of advertisement of the support group for supporting documentation. The Agency will contact the senior center after two months of no participants to discuss the promotion/marketing and the future of the caregiver support group. The caregiver support group must be organized/promoted by the senior center.

- b. Caregiver Information & Assistance: \$12.50 per unit for 24 units

budgeted for a total allocation of \$300. Supporting documentation is the Information & Assistance Intake Form.

- c. Caregiver Appreciation: \$500 has been allocated for a caregiver appreciation event that must be held between October 16th and December 15th. Cost incurred during the months of September – December can be submitted to the Agency for reimbursement. Invoices cannot be dated past December 31st. No gifts or gift cards can be given to the caregivers.

The Agency and Contractor therefore enter into the following:

II. Scope of Service

- A. This Contract provides for Family Caregiver Support services.
- B. As of the 2016 Reauthorization of the Older Americans Act, the following specific populations of caregivers are eligible to receive services:
 - Adult family members or other informal caregivers age 18 and older providing care to individuals 60 years of age and older
 - Adult family members or other informal caregivers age 18 and older providing care to individuals of any age with Alzheimer’s disease and related disorders
 - Older relatives (not parents) age 55 and older providing care to children under the age of 18; and
 - Older relatives, including parents, age 55 and older providing care to adults ages 18-59 with disabilities.
 -
- C. Services will be delivered at Columbus Senior Center.
- D. All Title III E Family Caregiver Support services provided will be delivered in a manner which conforms to Standards of the Nebraska Department of Health and Human Services, State Unit on Aging.

II. Contractor Duties

- A. Identify individuals eligible to receive Title III E Family Caregiver Support Services. This will inform older individuals and their caregivers of the availability of Title III E Family Caregiver Support services under this Contract.
- B. Provide the following Family Caregiver Support services but not limited to:
 - Caregiver Support Group
 - Caregiver Information & Assistance
- C. Provide a caregiver appreciation that can be to honor and acknowledge the

caregivers in their community.

- D. Submit financial/III E reports to the Agency as per the established schedule. Financial/III E reports must be filed to the Agency office by the 6th day of each month. Only error-free financial reports will be accepted by the Agency no later than 10:00 a.m. on the 6th day of each month. If your reports are received on or before the 5th at 5 p.m., Agency staff will attempt to contact you for needed corrections.

If Contractor is unavailable for corrections, no reimbursement will be disbursed that month. If Contractor cannot meet the report deadline, communication by the Contractor to the Agency may allow flexibility with deadline reimbursement.

When the 6th day of the month falls on a Saturday, reports are due the Friday before at or before 5:00 p.m. When the 6th day of the month falls on a Sunday, reports are due the Monday after at or before 10:00 a.m. Any Contractor failing to meet the reporting deadline will not get reimbursed for that month. Funding will be held until the following month or later if reports are not filed on time, incomplete or are inaccurate. Reimbursement occurs after the Governing Board meeting of the Agency on the third Thursday of each month.

Contractor agrees to provide the Agency with any and all data and information as may be requested, and Contractor shall promptly and accurately submit written information to Agency whenever requested to do so. All information shall be delivered via email. Examples of data and information include but not limited to sign in sheets, supporting documentation, etc.

- E. Contractor agrees to keep full and accurate sales, financial, procurement, and other necessary records relating to all items covered by this Contract. Contractor shall permit authorized auditors and officials to have access to all records for audit and review. In addition, authorized officials of the Agency shall have the right to conduct on-site or off-site reviews of but not limited to all files pertinent to the annual evaluation. Examples of data and information include but not limited to invoices, newsletters, etc.

The submission of any false or misleading report by Contractor or the request of the Contractor for the Agency to pay for the same service covered by any contractor shall result at the option of the Agency in the immediate cancellation of the Contract. Contractor shall be liable for any and all damages or loss caused by the submission of any false or misleading report.

- F. Personal purchases such as food, office items, personal motel charges made from the Contractor's accounts such as checking, savings, and/or credit card shall result at the option of the Agency in the immediate cancellation of the Contract.
- G. Gift cards/gift certificates are not allowed as a Title III E expense.
- H. Attend all meetings and trainings as requested by the Agency.

III. Agency Duties

- A. Reimburse the Contractor for units of services provided under this contract.
- B. Provide the Contractor with forms for reports, units of service and expenditures of services provided under this Contract.
- C. Work with the Contractor to develop local programs to reach the target population.
- D. Monitor the Title III E Family Caregiver Support Service activities to ensure that the terms and agreement of this Contract are fulfilled.
- E. The Agency shall indemnify and hold harmless Contractor for claims arising by reason of any act or omission of the Agency under this Contract.
- F. Provide training and hold meetings on an on-going basis for the Contractor about Family Caregiver Support activities.

IV. Administrative Provisions

- A. Contractor shall comply with all of the rules, regulations and policies of the Federal, State and Agency.
- B. All equipment purchased or repaired with funds resulting from this Contract shall remain property of the Contractor as long as the equipment is used to benefit the local program. This equipment cannot be sold or otherwise disposed of without obtaining the prior written permission of Agency.
- C. The Contractor shall have a working computer, scanner, and Internet at the Senior Center to provide the required information, receive communication from the Agency, and keep the confidential information at the Senior Center.
- D. In the event that program funds received by the Agency from the Nebraska Department of Health and Human Services are not allocated to the Agency, the Agency has the right to reduce the grant funds to the Contractor accordingly.
- E. Contractor agrees to indemnify and hold Agency harmless from and against all claims, damages, loss, and causes of action of whatever nature arising from any act, omission or negligence of Contractor or Contractor's agents, or employees to any person or the property of any person or arising from any accident, injury, or damage whatsoever caused to any person or the property of any person occurring during the term of the Contract. This shall include indemnity against all costs, expenses, and liabilities in or in connection with any such claim or proceeding brought thereon and in defense thereof, including reasonable attorney's fees.
- F. All provisions of the Contract are subject to the Americans with Disabilities Act.

V. Contract Compliance and Enforcement

It is the responsibility of the Agency staff to inform the Agency Executive Director of any Contractor's failure to comply with the terms of this Contract. Upon being notified by staff, Executive Director shall implement the procedure below to assure compliance with the terms of this Contract:

(A) Notification of Non-Compliance of III E Family Caregiver Support Program: After it has been determined by Agency staff that the terms of this Contract are not being met, written notification of non-compliance shall be sent to the Contractor by the Area Agency. The notification shall set forth the portion of the Contract being violated.

(1). Repeated Non-Compliance. In the event any or all of the violations, as determined above, have not been corrected, the Executive Director of the Agency shall notify the contractor in writing that funding shall be withheld until such time Contractor is in compliance. In the event the violations have not been corrected, the Executive Director of the Agency shall proceed as set forth herein.

(2) Loss of funding. The Executive Director of the Area Agency will notify the Contractor, in writing, if non-compliance continues and a new fiscal year begins, funding for the entire non-compliance period shall be lost. Current non-compliance of Contract will be presented to the Agency Governing Board for further action, which could result in loss of future funding, as set forth by the Governing Board.

(3) Grievance Procedure. See section V. (D)

(B) Grievance Procedure. In the event that a dispute arises under this Contractor with the caregiver support program within the senior center on the part of Contractor, such dispute shall first be taken to the Case Manager of the Caregiver Support Program or Fiscal Officer of the Agency. If said dispute is not settled to the satisfaction of Contractor, Contractor may then take said dispute to the Executive Director of the Agency. In the event said dispute is still unsettled, Contractor shall have the right to:

- Public Hearing. A public hearing may be requested by the Contractor if they have been notified in writing that they have not complied with the terms and conditions of this Contract and this Contract has been rendered null and void and payments have been terminated. Said request must be in written form and submitted to the Executive Director of the Agency within 5 days of notification of termination of this agreement. In the event the Compliance Board, as set forth herein, determines that the terms of this Contract were not violated, then those services provided by contractor after termination notice will be paid.

- Compliance Board. The Compliance Board shall consist of the Agency's

Governing Board Executive Committee, two other members of the Agency's Governing Board, two Advisory Board members, and one senior center manager, who shall be appointed annually by the Agency Governing Board to serve on such Compliance Board. No member of the Compliance Board may sit on said Board during a review if the violation involves a caregiver services site or political subdivision they represent. The Chairperson of the Compliance Board shall appoint someone else to temporarily replace that Compliance Board member. In the event the Compliance Board chairperson shall be involved, then the replacement shall be selected by the Vice-Chairperson of the Compliance Board. The sole purpose of the Compliance Board shall be to review the terms of the agreement and determine if the contractor is in violation of the terms and conditions of said Contract, when requested to do so. The recommendation(s) and or decision of the Compliance Board will be presented to and reviewed by the Agency's Governing Board, at their next regular meeting, whose decision shall be final.

VI. Termination or Suspension

This contract is contingent upon availability of funds. In the event funds for this service are not available to the Agency, the Agency may terminate the contract by written notice of 30 working days, and no further services or payment for services shall be rendered.

If either the Contractor or the Agency abandons, non-performs, or before completing, discontinues services or if the commencement, or timely completion of the service by either party is rendered improbably, infeasible, or illegal the other party may, by written notice of 30 days, terminate or suspend any or all of this obligation under this Contract until such time as the events or conditions resulting in such suspension has ceased or been corrected.

Either party may terminate this Contract by providing 30 days written notice of the termination to the other party.

Contractor may be required to reimburse Agency for any costs or expenses which may be disallowed as a result of an audit/monitoring by the Agency, federal/state government of agency thereof.

IN WITNESS THEREOF, this Contract has been executed by duly authorized officers this _____ day of _____ 2023.

Northeast Nebraska Area Agency on Aging (Agency)
By *Tom Smith*
Chairman, Governing Board

ATTEST: *Connie L. Cooper*
By _____
Connie L. Cooper, Executive Director, NENAAA

City of Columbus
(Contractor)
By _____
Board Chairman/designated person
Mayor

ATTEST
By _____
Manager/Coordinator

4.F. Invoice from Johnson Service Company in the amount of \$14,000 for emergency repairs to sewer main related to construction project on 23 Street and east 11 Avenue.



The City of
Columbus, Nebraska

PUBLIC WORKS DEPARTMENT

• Utility Billing • Water Production • Water/Sewer Utility • Wastewater •
Streets • MSW Transfer Station
Phone: 402-562-4260
Fax: 402-562-4265
www.columbusne.us

MEMORANDUM

DATE: May 25, 2023,
TO: City Administrator/Finance Director
FROM: Chuck Sliva, Public Works Director
SUBJECT: Sewer Main Emergency Repairs

RECOMMENDATION: To pay the following attached invoice from Johnson Service for the listed emergency repair to 15” sewer main point repair for the cost of \$14,000.00. The following repair was needed in conjunction with the sewer work related to the construction project on 23rd Street and East 11th Ave.

DISCUSSION: This needed repair was ordered by Public Works as the fastest and most cost effect manner to repair cracked 15” sewer main without any service interruption. Contractor estimated cost to remove and replace was estimated at \$25,000.00, plus long-term by-pass cost \$8,00.00 plus. The processed used took less than 8 Hours to complete.

FISCAL IMPACT:

Funds for this repair will come from the budgeted CIPP Liner Fund.

SIGNATURE:

By: _____ *Chuck Sliva* _____
Chuck Sliva, Public Works Director

Approved By: _____ *Heather Lindsley* _____
Heather Lindsley, Finance Director

Approved By: _____ *Tara Vasicek* _____
Tara Vasicek, City Administrator





PO Box 1065
 Kearney NE 68848
 (308) 237-6651, (308) 440-8464
 jkrehn@jshillandscontracting.com

Invoice

DATE	05/23/2023
INVOICE #	17075
TERMS	NET 30

BILL TO
CITY OF COLUMBUS P O BOX 1677 COLUMBUS, NE, 68602 (402) 276-9733 JANELLE.KLINE@COLUMBUSNE.US

SERVICE LOCATION
CITY OF COLUMBUS P O BOX 1677 COLUMBUS, NE, 68602

JOB#	DATE	PO
1019454648	05/08/2023	COLU72

Description	Qty	Rate	Tax	Total
Mobilization - LS	1.00	\$4,000.00	\$0.00	\$4,000.00
Install 15" Point Repair Liner - EA	2.00	\$5,000.00	\$0.00	\$10,000.00

CUSTOMER MESSAGE
Work Dates - 5/8-5/10/23

Invoice Total:	\$14,000.00
Deposits (-):	\$0.00
Payments (-):	\$0.00
Total Due:	\$14,000.00

4.G. Resolution No. R23-74 approving agreement with Geo-Comm, Inc. in the amount of \$34,174 for GIS maintenance services, for joint communications center.

RESOLUTION NO. R23-74

A RESOLUTION OF THE MAYOR AND COUNCIL OF THE CITY OF COLUMBUS, NEBRASKA, APPROVING AN AGREEMENT WITH GEO-COMM, INC. FOR GIS MAINTENANCE SERVICES IN THE AMOUNT OF \$34,174 A COPY OF WHICH IS ATTACHED HERETO AND INCORPORATED HEREIN; TO AUTHORIZE THE MAYOR TO EXECUTE THE SAME ON BEHALF OF THE CITY; AND TO REPEAL ALL RESOLUTIONS OR PORTIONS THEREOF IN CONFLICT HEREWITH.

WHEREAS, GIS mapping for E-911 related calls is necessary for the operation of the Joint Communications Center.

NOW THEREFORE, BE IT RESOLVED BY THE MAYOR AND COUNCIL OF THE CITY OF COLUMBUS, NEBRASKA, that the agreement with Geo-Comm, Inc. in the amount of \$34,174 for GIS maintenance services through June 30, 2025, a copy of which is attached hereto and incorporated herein by this reference, is hereby approved and the mayor is authorized, directed, and empowered to execute the same on behalf of the City of Columbus.

This resolution shall repeal all resolutions or portions thereof in conflict herewith.

INTRODUCED BY COUNCIL MEMBER _____

PASSED AND ADOPTED THIS ____ DAY OF _____, 2023.

MAYOR

ATTEST:

CITY CLERK

APPROVED AS TO FORM:

CITY ATTORNEY



The City of Columbus

RESPONSIBLE • RESPONSIVE • REPUTABLE

Communications (402) 564-3201

Fax (402) 565-0660

DATE: May 16, 2023
TO: Columbus-Platte County Joint Communications Committee
FROM: Rachel Pensick, Communications Director
RE: GeoComm, Inc. GIS Maintenance Contract

RECOMMENDATION:

To approve the purchase of a two-year GIS Maintenance service contract from GeoComm, Inc.

DISCUSSION:

The Columbus-Platte County Joint Communications Center operates as the Public Safety Answering Point for Platte and Polk Counties. Consistent and accurate GIS is the foundation of the 911 call routing process. The JCC currently has a GIS Maintenance service contract with GeoComm that expires in June 2023. The JCC absorbed the Polk County contract for GIS services and that expires in May 2023. Geo-Comm has proposed a two-year GIS Maintenance service contract to begin on May 1, 2023 and expire on June 30, 2025.

There are many things in this contract that require technicians to support the process. Included in that list are:

- Maintaining of the MSAG (Master Street Address Guide)
- Assigning new addresses to rural locations
- Completion of routing sheets
- Consolidation of East Central 911 Regional Data

Fiscal Impact:

The two-year contract will cost \$34,174. It will be invoiced annually. The year one cost is \$17,499 and the year two cost is \$16,675. These are budgeted costs.

Concurrence:

The Columbus-Platte County Joint Communications Center Committee reviewed and approved the purchase.

SIGNATURE:

By: Rachel Pensick
Rachel Pensick – Communications Director

Approved: Tara Vasicek
Tara Vasicek – City Administrator

Approved: Heather Lindsley
Heather Lindsley – Finance Director





GIS Maintenance Services

Contract #005168

April 14, 2023

Geo-Comm, Inc.
EIN # 41-1811590
601 West St. Germain
St. Cloud, MN 56301
Phone: (320) 240-0040
www.geocomm.com

Columbus/Platte County Joint Communications Center
Rachel Pensick, Director
2419 14th St
Columbus, NE 68601
Phone: (402) 942-5062
E-mail: rachel.pensick@columbusne.us

Columbus/Platte Maintenance Services	Service Dates	Total
GIS Map Data Maintenance	7/1/2023-6/30/2024	\$6,840
MSAG and ALI Maintenance	7/1/2023-6/30/2024	\$1,824
GIS Addressing Services	7/1/2023-6/30/2024	\$3,069
GIS Map Data Maintenance	7/1/2024-6/30/2025	\$6,840
MSAG and ALI Maintenance	7/1/2024-6/30/2025	\$1,824
GIS Addressing Services	7/1/2024-6/30/2025	\$3,069
Contract Total:		\$23,466

Polk County Maintenance Services	Service Dates	Total
GIS Map Data Maintenance	5/1/2023-6/30/2023	\$640
MSAG and ALI Maintenance	5/1/2023-6/30/2023	\$184
GIS Map Data Maintenance	7/1/2023-6/30/2024	\$3,840
MSAG and ALI Maintenance	7/1/2023-6/30/2024	\$1,102
GIS Map Data Maintenance	7/1/2024-6/30/2025	\$3,840
MSAG and ALI Maintenance	7/1/2024-6/30/2025	\$1,102
Contract Total:		\$10,708

GIS maintenance services will be provided to Polk County, Nebraska from May 1, 2023 through June 30, 2025. Services will be provided to Columbus/Platte County July 1, 2023 through June 30, 2025.

A description of the services covered under this contract is attached and made a part of this agreement as Exhibit A. Note that GIS Addressing Services are for Columbus/Platte County only and exclude Polk County.

Customer agrees to pay GeoComm \$34,174 on the following schedule:

- \$17,499 – invoiced net 45 days on July 1, 2023
- \$16,675 – invoiced net 45 days on July 1, 2024

Customer Authorization

Signature	
Print Name	
Purchase Order # (if required)	
Date	

Exhibit A – Scope of Work

GIS Data Layers Maintenance Services

GeoComm will use provided resources, including digital copies of the MSAG and ALI database, to update GIS data layers for location validation in 9-1-1 systems. As needed, GeoComm will:

- Update the Road Centerline layer with additions, deletions, and corrections
- Update the Site/Structure Address Point layer with additions, deletions, and corrections
- Update Service Boundary Layers (PSAP, police, fire, EMS, and ESZ/ESN) with additions, deletions, and corrections when requested
- Update the Provisioning Boundary Layer with additions, deletions, and corrections.
- Update the Incorporated Municipality Layer when there are annexations

GIS data attribute standardization following the NENA Standard for NG9-1-1 GIS Data Model and/or your PSAP mapping system requirements are included. GeoComm will populate Mandatory and Conditional attributes with provided resources.

GeoComm will perform quality control (QC) checks on GIS data to measure GIS data quality and synchronization with MSAG and ALI databases, if available. If GIS data errors are detected, GeoComm will make appropriate corrections. If MSAG or ALI errors are detected, GeoComm will correct the error if contracted to do so. If resolving the MSAG or ALI errors are outside of the scope of service, GeoComm will provide you with a list of required updates.

GeoComm will provide updated GIS data packages (zip file containing the updated GIS data layers in file geodatabase format) for you to provision into your local 9-1-1 systems. If the local 9-1-1 system is a GeoComm mapping application, GeoComm will execute the update process.

If requested, GeoComm can provide.pdf files representing one combined Service Boundary map (Police, Fire, EMS) which you can print to hard copy wall maps.

MSAG and ALI Maintenance Services

To ensure ongoing synchronization with GIS data layers, MSAG, and ALI database, GeoComm will update and manage your MSAG based on provided resources. As needed, GeoComm will:

- Submit MSAG updates to your database provider when roads are added, changed, or deleted if allowed access to the database provider's MSAG maintenance system.
- Assist in the resolution of MSAG discrepancies, as provided by the database provider (E.g. overlaps with other MSAG entries, address validation, etc.)
- Assist in the resolution of inconsistencies between the MSAG and GIS data layers.
- Assist in the resolution of telephone (TN) records that do not match the MSAG.
- Request new Emergency Service Numbers (ESNs) from the database provider when new responder combinations are created.
- Complete periodic reviews of the MSAG, ALI database, and GIS data layers to ensure a high synchronization Rate and complete updates.

Note: If clarification is needed, GeoComm will work with you to ensure accurate updates are made.

Address Assignment Services – Columbus/Platte County

Note that Polk County is excluded from Address Assignment Services.

GeoComm will update the Site/Structure Address Point layer for Columbus/Platte County based on resources provided. As needed, GeoComm will:

- Update the Site/Structure Address Point layer with new address point locations using provided accurate location information or latitude and longitude for the approximate placement of the address point.
- Assign addresses to newly added points based on the road centerline layer attributes (street name and address ranges) and return the newly assigned addresses within three business days.
- Provide support regarding unique addressing situations or addressing discrepancies.

Note: GeoComm is not responsible for notifying residents of the newly assigned addresses.

GIS Maintenance Bureau Contact Information

Email: gis@geocomm.com

Phone: 1.844.282.4507

Upload Data: <http://www.geo-comm.com/industries/gis/data-submission/>

Uploading Data Notes: Adobe Flash must be installed to upload files. All files must be compressed into a single (.zip) format. The zip file must be under 2GB. A confirmation e-mail will be sent once the file is received.

Additional terms and conditions around cancellations can be found at: <https://www.geo-comm.com/terms/>

4.H. Resolution No. R23-75 authorizing payment of various improvement projects.

RESOLUTION NO. R23-75

A RESOLUTION OF THE MAYOR AND COUNCIL OF THE CITY OF COLUMBUS, NEBRASKA, TO AUTHORIZE AND DIRECT THAT A CHECK BE ISSUED AND MADE PAYABLE TO THE RESPECTIVE CONTRACTOR(S) FOR LABOR, EQUIPMENT, AND MATERIALS FURNISHED FOR IMPROVEMENTS IN THE FOLLOWING DESIGNATED DISTRICTS AND PROJECTS WITHIN THE CITY OF COLUMBUS, ALL AS SET FORTH ON THE ATTACHED CERTIFICATES OF PROGRESS PREPARED BY THE RESPECTIVE SPECIAL ENGINEER TO WIT B-D CONSTRUCTION, INC., COLUMBUS FIRE STATION #2, \$128,685.39; GEHRING CONSTRUCTION AND READY MIX CO. INC., SID NO. 189 48 AVENUE FROM 23 STREET TO SOUTH OF BRADSHAW PARK ENTRANCE & CONCRETE PAVING IMPROVEMENTS 2023, \$813,356.46; GEHRING CONSTRUCTION AND READY MIX CO., INC., SID NO. 184 – 23 STREET FROM EAST OF 48 AVENUE TO 54 AVENUE, \$92,234.00; PLATTE VALLEY PRECAST, AIRPORT HANGAR, \$43,159.95.

WHEREAS, the mayor and council of the City of Columbus, Nebraska, hereby find and determine that pursuant to contract, labor, equipment, and materials have been furnished for improvements in the following designated districts and projects within said City, to wit:

B-D Construction, Inc.	Columbus Fire Station #2	\$ 128,685.39
Gehring Construction & Ready Mix Co.	SID No. 189 48 Ave. from 23 St. to S. of Bradshaw Park Entrance & Concrete Paving Improve 2023	\$ 813,356.46
Gehring Construction & Ready Mix Co.	SID No. 184 23 St. from E 48 Ave. to 54 Ave.	\$ 92,234.00
Platte Valley Precast	Airport Hangar	\$ 43,159.95

that the respective special engineer has prepared and filed with the city clerk a certificate of progress respecting said improvements, copies of which are attached and are hereby incorporated herein by reference and made a part hereof as if fully set forth herein; and that pursuant to said contract, the plans, specifications, and said certificate of progress, there is due the respective contractor on account the amount as set forth in the attached.

NOW, THEREFORE, BE IT RESOLVED BY THE MAYOR AND COUNCIL OF THE CITY OF COLUMBUS, NEBRASKA, that the said improvements in the aforesaid districts and projects and the respective certificate of progress be and are hereby accepted and adopted; that a check be issued and made payable to the respective contractor in the amount and in the manner as set forth in the respective certificate of progress; that each check shall be drawn on the appropriate and respective fund; that each check shall be redeemed and paid upon collection of special assessments and sale of various purpose bonds at the completion of each of said districts and projects.

INTRODUCED BY COUNCIL MEMBER _____

PASSED AND ADOPTED THIS _____ DAY OF _____, 2023.

MAYOR

ATTEST:

CITY CLERK

APPROVED AS TO FORM:

CITY ATTORNEY



Contractor's Application and Certificate of Payment

Contractor's Application for Payment No: 9	
Application Period: (From - to) 4/18/23 to 5/23/23	
To: City of Columbus (Owner)	From (Contractor): Gehring Construction & Ready Mix Co., Inc.
Contractor's Project No.:	
Project Name: SID No. 184 - 23rd Street from East of 48th Avenue to 54th Avenue	
Via (Consulting Engineer / Architect):	
Fiscal Year Budget Number: 200-200-57300-20076	

Application For Payment

Field Order and Change Order Summary

Field (FO#) and Change Orders (CO#) Approved:		
Number	Additions	Deductions
FO #1	\$ 81,578.00	
TOTALS	\$ 81,578.00	\$ -
NET CHANGE	\$ 81,578.00	

1. ORIGINAL CONTRACT PRICE.....	\$	2,417,125.60
2. Net change by Field Order and Change Orders.....	\$	81,578.00
3. Current Contract Price (Line 1 ± 2).....	\$	2,498,703.60
4. TOTAL COMPLETED AND STORED TO DATE (Column H on Progress Estimate).....	\$	2,473,699.00
5. RETAINAGE: (Capped at 10% at 50% of Line 3) (When line 4 is over 50% of Line 3 do calculation of Line 3 x .5 x .1 to get Retainage)	\$	124,935.18
6. AMOUNT ELIGIBLE TO DATE (Line 4 - Line 5).....	\$	2,348,763.82
7. LESS PREVIOUS PAYMENTS (Line 6 from prior Application).....	\$	2,256,529.82
8. AMOUNT DUE THIS APPLICATION (Line 6 - Line 7).....	\$	92,234.00
9. BALANCE TO FINISH, PLUS RETAINAGE (Line 3- Line 6).....	\$	149,939.78

(To double check Line 9 Take Column I + Line 5 should = Line 9 calculations)

Contractor's Certification

The undersigned Contractor certifies that to the best of the Contractor's knowledge, information and belief, the Work covered by this Application for Payment has been completed in accordance with the Contract Documents, that all amounts have been paid by the Contractor for Work for which previous Certificates for Payment were issued and payments received from the Owner, and that current payment shown herein is now due.

Contractor: Gehring Construction & Ready Mix Co., Inc.

By: Stephen Anderson Date: 5-23-23

Printed/Typed Name: Stephen Anderson

Payment of:

(Line 8 or other - attach explanation of the other amount)

is recommended by:

(Consulting Engineer/Architect) (Date)

Payment of:

\$ _____ 92,234.00

(Line 8 or other - attach explanation of the other amount)

is approved by:

Richard J. Bogue 5-23-2023

(City Engineer) (Date)

Approved by:

Funding Agency (if applicable) (Date)

APPLICATION AND CERTIFICATE FOR PAYMENT

Containing Contractor's signed Certification is attached

Project Name:			Contractor's Pay Application:								
SID No. 184 - 23rd Street from East of 48th Avenue to 54th Avenue			9								
Application Period: (From - To)			4/18/23 to 5/23/23								
A			B	C	D	E	F	G	H		I
Item			Bid Quantity	Unit Price	Bid Value (D*E)	Estimated Quantity Installed	Value Installed (G*E)	Material Presently Stored	Total Completed and Stored to Date (F+G)	% (F) B (H/F*100)	Balance to Finish (D - H)
Bid Item No.	Description	Unit of Measure									
23rd Street from E 48th Ave. to 54th Ave.											
1	Mobilization	JOB	1	\$ 95,000.00	\$ 95,000.00	0.75	\$ 71,250.00		\$ 71,250.00	75	\$ 23,750.00
2	Traffic and Pedestrian Control, including Detour	JOB	1	\$ 15,000.00	\$ 15,000.00	1	\$ 15,000.00		\$ 15,000.00	100	\$ -
3	NPDES, SWPPP, and BMP Maintenance	JOB	1	\$ 5,000.00	\$ 5,000.00	1	\$ 5,000.00		\$ 5,000.00	100	\$ -
4	Curb or Grate Inlet Filter BMP	EA	30	\$ 200.00	\$ 6,000.00	30	\$ 6,000.00		\$ 6,000.00	100	\$ -
5	Erosion Control Matting	SF	882	\$ 1.60	\$ 1,411.20	1,200	\$ 1,920.00		\$ 1,920.00	136	\$ (508.80)
6	Sediment Control Silt Fence	LF	1,790	\$ 2.85	\$ 5,101.50	1,850	\$ 5,272.50		\$ 5,272.50	103	\$ (171.00)
7	Clearing and Grubbing, Includes Trimming Trees	JOB	1	\$ 15,000.00	\$ 15,000.00	1	\$ 15,000.00		\$ 15,000.00	100	\$ -
8	Remove and Mill Asphalt Paving	SY	7,795	\$ 6.50	\$ 50,667.50	8,119	\$ 52,773.50		\$ 52,773.50	104	\$ (2,106.00)
9	Remove Concrete Paving	SY	1,090	\$ 16.00	\$ 17,440.00	1,102	\$ 17,632.00		\$ 17,632.00	101	\$ (192.00)
10	Remove Culvert All Sizes Including Headwalls and FES	EA	775	\$ 12.00	\$ 9,300.00	799	\$ 9,588.00		\$ 9,588.00	103	\$ (288.00)
11	Remove Inlet	EA	2	\$ 1,000.00	\$ 2,000.00	2	\$ 2,000.00		\$ 2,000.00	100	\$ -
12	Remove Junction Box Top, Construct MH Top	EA	3	\$ 2,500.00	\$ 7,500.00	8	\$ 20,000.00		\$ 20,000.00	267	\$ (12,500.00)
13	Remove, Temporary Set, and Reset Mailbox	EA	7	\$ 500.00	\$ 3,500.00	10	\$ 5,000.00		\$ 5,000.00	143	\$ (1,500.00)
14	Remove and Reset Traffic Sign	EA	6	\$ 300.00	\$ 1,800.00	5	\$ 1,500.00		\$ 1,500.00	83	\$ 300.00
15	Remove Sign, salvage to City	EA	3	\$ 100.00	\$ 300.00	3	\$ 300.00		\$ 300.00	100	\$ -
16	Temporary Drive Surfacing and Maintenance	JOB	1	\$ 5,000.00	\$ 5,000.00	1	\$ 5,000.00		\$ 5,000.00	100	\$ -
17	9-inch P.C. Concrete with 1 1/4" Doweled Paving NDOT Type 47B-3500	SY	13,260	\$ 64.00	\$ 848,640.00	13,493	\$ 863,552.00		\$ 863,552.00	102	\$ (14,912.00)
18	8-inch P.C. Concrete Driveway Paving NDOT Type 47B-3500	SY	1,291	\$ 64.00	\$ 82,624.00	1,115	\$ 71,360.00		\$ 71,360.00	86	\$ 11,264.00
19	6-inch P.C. Concrete Street Paving NDOT Type 47B-3500	SY	117	\$ 60.00	\$ 7,020.00	339	\$ 20,340.00		\$ 20,340.00	290	\$ (13,320.00)
20	6-inch P.C. Concrete Trail Paving, including Handicap Ramps, NDOT Type 47B-3500	SY	2,928	\$ 60.00	\$ 175,680.00	2,777	\$ 166,620.00		\$ 166,620.00	95	\$ 9,060.00
21	6-inch P.C. Concrete Driveway Paving, NDOT Type 47B-3500	SY	226	\$ 60.00	\$ 13,560.00	451	\$ 27,060.00		\$ 27,060.00	200	\$ (13,500.00)
22	5-inch P.C. Concrete Sidewalk Paving, NDOT Type 47B-3500	SY	1,111	\$ 75.00	\$ 83,325.00	1,134	\$ 85,050.00		\$ 85,050.00	102	\$ (1,725.00)
23	1.5 Foot Concrete Header	LF	97	\$ 20.00	\$ 1,940.00	265	\$ 5,300.00		\$ 5,300.00	273	\$ (3,360.00)
24	ADA Handicap Ramp Detectable Warning Panel	SF	212	\$ 35.00	\$ 7,420.00	284	\$ 9,940.00		\$ 9,940.00	134	\$ (2,520.00)
25	4-inch Aggregate Paving Subbase	SY	16,020	\$ 16.00	\$ 256,320.00	16,020	\$ 256,320.00		\$ 256,320.00	100	\$ -
26	Underdrain System, including 4-inch Perforated PVC Pipe, Rock, Fabric, Complete in Place.	LF	5,718	\$ 14.00	\$ 80,052.00	5,106	\$ 71,484.00		\$ 71,484.00	89	\$ 8,568.00
27	Temporary Aggregate Drive Surfacing, Removal, and Maintenance	JOB	1	\$ 15,000.00	\$ 15,000.00	1	\$ 15,000.00		\$ 15,000.00	100	\$ -
PAGE 1 TOTALS					\$ 1,811,601.20		\$ 1,825,262.00		\$ 1,825,262.00		\$ (13,660.80)

Project Name: SID No. 184 - 23rd Street from East of 48th Avenue to 54th Avenue				Contractor's Pay Application: 9							
Application Period: (From - To) 4/18/23 to 5/23/23											
A			B	C	D	E	F	G	H		I
Item			Bid Quantity	Unit Price	Bid Value (D*E)	Estimated Quantity Installed	Value Installed (G*E)	Material Presently Stored	Total Completed and Stored to Date (F+G)	% (F) B (H/F*100)	Balance to Finish (D - H)
Bid Item No.	Description	Unit of Measure									
28	Adjust Manhole to Grade	EA	17	\$ 750.00	\$ 12,750.00	14	\$ 10,500.00		\$ 10,500.00	82	\$ 2,250.00
29	Adjust Water Valve Box to Grade	EA	6	\$ 750.00	\$ 4,500.00	9	\$ 6,750.00		\$ 6,750.00	150	\$ (2,250.00)
30	Adjust Fire Hydrant to Grade, 12-inch Extension	EA	1	\$ 850.00	\$ 850.00	1	\$ 850.00		\$ 850.00	100	\$ -
31	Monument Well	EA	3	\$ 1,000.00	\$ 3,000.00	2	\$ 2,000.00		\$ 2,000.00	67	\$ 1,000.00
32	6-foot Open Throat Inlet	EA	18	\$ 4,800.00	\$ 86,400.00	22	\$ 105,600.00		\$ 105,600.00	122	\$ (19,200.00)
33	Grate Inlet	EA	14	\$ 3,000.00	\$ 42,000.00	15	\$ 45,000.00		\$ 45,000.00	107	\$ (3,000.00)
34	Area Inlet	EA	2	\$ 3,500.00	\$ 7,000.00	2	\$ 7,000.00		\$ 7,000.00	100	\$ -
35	Junction Box	EA	14	\$ 5,500.00	\$ 77,000.00	14	\$ 77,000.00		\$ 77,000.00	100	\$ -
36	24-inch RCP Class III Storm Sewer	LF	166	\$ 92.50	\$ 15,355.00	166	\$ 15,355.00		\$ 15,355.00	100	\$ -
37	18-inch RCP Class III Storm Sewer	LF	512	\$ 66.50	\$ 34,048.00	525	\$ 34,912.50		\$ 34,912.50	103	\$ (864.50)
38	15-inch RCP Class III Storm Sewer	LF	871	\$ 66.50	\$ 57,921.50	871	\$ 57,921.50		\$ 57,921.50	100	\$ -
39	10-inch PVC Schedule 40 Storm Sewer	LF	235	\$ 58.00	\$ 13,630.00	235	\$ 13,630.00		\$ 13,630.00	100	\$ -
40	24-inch Concrete Flared End Section	EA	2	\$ 1,250.00	\$ 2,500.00	2	\$ 2,500.00		\$ 2,500.00	100	\$ -
41	15-inch Concrete Flared End Section	EA	5	\$ 750.00	\$ 3,750.00	5	\$ 3,750.00		\$ 3,750.00	100	\$ -
42	24-inch Concrete Bend with Collar	EA	1	\$ 750.00	\$ 750.00	1	\$ 750.00		\$ 750.00	100	\$ -
43	15-inch Concrete Bend with Collar	EA	1	\$ 700.00	\$ 700.00	1	\$ 700.00		\$ 700.00	100	\$ -
44	Connect to Existing Box Culvert	EA	1	\$ 1,200.00	\$ 1,200.00	1	\$ 1,200.00		\$ 1,200.00	100	\$ -
45	Connect to Existing Pipe with Collar, All Sizes	EA	5	\$ 650.00	\$ 3,250.00	6	\$ 3,900.00		\$ 3,900.00	120	\$ (650.00)
46	Plug 24-inch Box Opening	EA	2	\$ 450.00	\$ 900.00	2	\$ 900.00		\$ 900.00	100	\$ -
47	Over Excavation and Broken Concrete Rip Rap	JOB	1	\$ 5,000.00	\$ 5,000.00	1	\$ 5,000.00		\$ 5,000.00	100	\$ -
48	Segmental Retaining Wall System	SF	236	\$ 90.00	\$ 21,240.00	471	\$ 42,390.00		\$ 42,390.00	200	\$ (21,150.00)
49	Gravel Surfacing of Driveways	JOB	1	\$ 5,000.00	\$ 5,000.00	1	\$ 5,000.00		\$ 5,000.00	100	\$ -
50	Crushed Rock Surfacing of Driveways	JOB	1	\$ 5,000.00	\$ 5,000.00	1	\$ 5,000.00		\$ 5,000.00	100	\$ -
51	Speed Limit Sign and Telespar Post, all speeds	EA	7	\$ 270.00	\$ 1,890.00	7	\$ 1,890.00		\$ 1,890.00	100	\$ -
52	Center Turn Lane Sign with No Parking Sign on Telespar Post	EA	4	\$ 285.00	\$ 1,140.00		\$ -		\$ -	0	\$ 1,140.00
53	Stop Sign on Telespar Post	EA	4	\$ 235.00	\$ 940.00	2	\$ 470.00		\$ 470.00	50	\$ 470.00
54	Stop Sign Ahead on Telespar Post	EA	3	\$ 250.00	\$ 750.00	3	\$ 750.00		\$ 750.00	100	\$ -
55	Vehicle Directional Sign Ahead on Telespar Post	EA	1	\$ 325.00	\$ 325.00		\$ -		\$ -	0	\$ 325.00
56	Delineator Diamond Sign	EA	2	\$ 250.00	\$ 500.00	2	\$ 500.00		\$ 500.00	100	\$ -
57	Delineator Angled Sign	EA	4	\$ 210.00	\$ 840.00	4	\$ 840.00		\$ 840.00	100	\$ -
58	Temporary Centerline Marking Paint	LF	3,100	\$ 0.38	\$ 1,178.00		\$ -		\$ -	0	\$ 1,178.00
59	Paint Striping, 4-inch Yellow, Solid, and Dashed	LF	6,321	\$ 5.52	\$ 34,891.92		\$ -		\$ -	0	\$ 34,891.92
60	Paint Striping, 4-inch White Solid	LF	96	\$ 3.68	\$ 353.28		\$ -		\$ -	0	\$ 353.28
61	Paint Striping, 24-inch White Solid	LF	189	\$ 29.50	\$ 5,575.50		\$ -		\$ -	0	\$ 5,575.50
62	Paint Striping, 12-inch White Solid	LF	87	\$ 12.60	\$ 1,096.20		\$ -		\$ -	0	\$ 1,096.20
63	Hydro Seed Disturbed Areas	ACRE	2.2	\$ 9,000.00	\$ 19,800.00	2.2	\$ 19,800.00		\$ 19,800.00	100	\$ -
64	Overexcavation and Crushed Concrete	TON	500	\$ 75.00	\$ 37,500.00		\$ -		\$ -	0	\$ 37,500.00
65	Earthwork, Final Grading, Backfillings, and Shaping	JOB	1	\$ 95,000.00	\$ 95,000.00	1	\$ 95,000.00		\$ 95,000.00	100	\$ -
PAGE 2 TOTALS					\$ 605,524.40		\$ 566,859.00		\$ 566,859.00		\$ 38,665.40

Project Name: SID No. 184 - 23rd Street from East of 48th Avenue to 54th Avenue				Contractor's Pay Application: 9							
Application Period: (From - To) 4/18/23 to 5/23/23											
A			B	C	D	E	F	G	H		I
Item			Bid Quantity	Unit Price	Bid Value (D*E)	Estimated Quantity Installed	Value Installed (G*E)	Material Presently Stored	Total Completed and Stored to Date (F+G)	% (F) B (H/F*100)	Balance to Finish (D - H)
FO 1 Item No.	Description	Unit of Measure									
FO1 1	8" PVC SDR26 Sanitary Sewer Main with Bedding	LF	570	\$ 77.00	\$ 43,890.00	570	\$ 43,890.00		\$ 43,890.00	100	\$ -
FO1 2	4" PVC Schedule 40 Sanitary Sewer Service Line	LF	115	\$ 52.00	\$ 5,980.00	115	\$ 5,980.00		\$ 5,980.00	100	\$ -
FO1 3	Manhole	VF	13	\$ 1,150.00	\$ 14,950.00	13	\$ 14,950.00		\$ 14,950.00	100	\$ -
FO1 4	8" x 4" Service Wye	EA	5	\$ 360.00	\$ 1,800.00	5	\$ 1,800.00		\$ 1,800.00	100	\$ -
FO1 5	Connect Existing Sewer Service Line	EA	2	\$ 350.00	\$ 700.00	2	\$ 700.00		\$ 700.00	100	\$ -
FO1 6	Connect to Existing Manhole	EA	1	\$ 1,400.00	\$ 1,400.00	1	\$ 1,400.00		\$ 1,400.00	100	\$ -
FO1 7	1" HDPE SDR 7 Water Service Line	LF	128	\$ 28.50	\$ 3,648.00	128	\$ 3,648.00		\$ 3,648.00	100	\$ -
FO1 8	1" Curb Stop with Roadway Box	EA	3	\$ 800.00	\$ 2,400.00	3	\$ 2,400.00		\$ 2,400.00	100	\$ -
FO1 9	1" Corp Stop with Service Saddle	EA	3	\$ 800.00	\$ 2,400.00	3	\$ 2,400.00		\$ 2,400.00	100	\$ -
FO1 10	Remove 6" Sanitary Sewer Main	LF	315	\$ 14.00	\$ 4,410.00	315	\$ 4,410.00		\$ 4,410.00	100	\$ -
FIELD ORDER 1 TOTALS					\$ 81,578.00		\$ 81,578.00		\$ 81,578.00		\$ -
GRAND TOTAL OF ITEMS 1-65 plus FO #1					\$ 2,498,703.60		\$ 2,473,699.00		\$ 2,473,699.00		\$ 25,004.60

AIA Type Document
Application and Certification for Payment

TO (OWNER): City of Columbus
 2424 14th Street
 COLUMBUS, NE 68601

PROJECT: COLUMBUS FIRE STATION #2
 424 8th Street
 Columbus, NE 68601

APPLICATION NO: 13
PERIOD TO: 4/30/2023

DISTRIBUTION TO:
 OWNER
 ARCHITECT
 _ CONTRACTOR

FROM (CONTRACTOR): B-D Construction, Inc.
 2154 East 32nd Avenue
 Columbus, NE 68601

VIA (ARCHITECT): WSKF, Inc.
 110 Armour Road
 North Kansas City, MO 64116

ARCHITECT'S PROJECT NO: 20023

CONTRACT FOR: General Construction

CONTRACT DATE: 5/16/2022

CONTRACTOR'S APPLICATION FOR PAYMENT

Application is made for Payment, as shown below, in connection with the Contract. Continuation Sheet, AIA Type Document is attached.

1. ORIGINAL CONTRACT SUM	\$	<u>1,802,494.00</u>
2. Net Change by Change Orders	\$	<u>110,279.38</u>
3. CONTRACT SUM TO DATE (Line 1 + 2)	\$	<u>1,912,773.38</u>
4. TOTAL COMPLETED AND STORED TO DATE	\$	<u>1,906,048.38</u>
5. RETAINAGE:		
a. <u>5.00</u> % of Completed Work	\$	<u>95,302.42</u>
b. <u>0.00</u> % of Stored Material	\$	<u>0.00</u>
Total retainage (Line 5a + 5b)	\$	<u>95,302.42</u>
6. TOTAL EARNED LESS RETAINAGE	\$	<u>1,810,745.96</u>
(Line 4 less Line 5 Total)		
7. LESS PREVIOUS CERTIFICATES FOR PAYMENT (Line 6 from prior Certificate)	\$	<u>1,682,060.57</u>
8. CURRENT PAYMENT DUE	\$	<u>128,685.39</u>
9. BALANCE TO FINISH, INCLUDING RETAINAGE (Line 3 less Line 6)	\$	<u>102,027.42</u>

CHANGE ORDER SUMMARY	ADDITIONS	DEDUCTIONS
Total changes approved in previous months by Owner	110,279.38	0.00
Total approved this Month	0.00	0.00
TOTALS	110,279.38	0.00
NET CHANGES by Change Order	110,279.38	

The Undersigned Contractor certifies that to the best of the Contractor's knowledge, information and belief the work covered by this application for Payment has been completed in accordance with the Contract Documents, that all amounts have been paid by the Contractor for Work for which previous Certificates for Payment were issued and payments received from the owner, and that current payment shown herein is now due.

CONTRACTOR: B-D Construction, Inc.
 2154 East 32nd Avenue Columbus, NE 68601

By: Bryan L. Kearney / Treasurer
 State of: NE
 County of: Platte
 Date: 5.1.23

Subscribed and Sworn to before me this 1st Day of May 20 23
 Notary Public: Cheryl L Brewer
 My Commission Expires: May 19, 2025

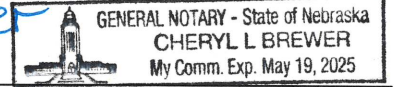

ARCHITECT'S CERTIFICATE FOR PAYMENT

In Accordance with the Contract Documents, based on on-site observations and the data comprising the above application, the Architect certifies to owner that to the best of the Architect's knowledge, information and belief the Work has progressed as indicated, the quality of the work is in accordance with the Contract Documents, and the Contractor is entitled to payment of the AMOUNT CERTIFIED.

AMOUNT CERTIFIED \$ 128,685.39

(Attach explanation if amount certified differs from the amount applied. Initial all figures on this Application and on the Continuation Sheet that are changed to conform to the amount certified.)

ARCHITECT: WSKF, Inc.
 By: _____ Date: 05/09/2023

This Certificate is not negotiable. The AMOUNT CERTIFIED is payable only to the Contractor named herein. Issuance, Payment and acceptance of payment are without prejudice to any rights of the Owner or Contractor under this Contract.

AIA Type Document
Application and Certification for Payment

TO (OWNER): City of Columbus
 2424 14th Street
 COLUMBUS, NE 68601

PROJECT: COLUMBUS FIRE STATION #2
 424 8th Street
 Columbus, NE 68601

APPLICATION NO: 13
PERIOD TO: 4/30/2023

DISTRIBUTION TO:
 _ OWNER
 _ ARCHITECT
 _ CONTRACTOR

FROM (CONTRACTOR): B-D Construction, Inc.
 2154 East 32nd Avenue
 Columbus, NE 68601

VIA (ARCHITECT): WSKF, Inc.
 110 Armour Road
 North Kansas City, MO 64116

ARCHITECT'S PROJECT NO: 20023

CONTRACT FOR: General Construction

CONTRACT DATE: 5/16/2022

ITEM	DESCRIPTION	SCHEDULE VALUE	PREVIOUS APPLICATIONS	COMPLETED THIS PERIOD	STORED MATERIAL	COMPLETED STORED	%	BALANCE	RETAINAGE
1	General Conditions	94,881.00	76,676.52	18,204.48	0.00	94,881.00	100.00	0.00	4,744.05
2	Select Demolition	14,451.00	14,451.00	0.00	0.00	14,451.00	100.00	0.00	722.55
3	Reinforcing Steel	10,653.00	10,653.00	0.00	0.00	10,653.00	100.00	0.00	532.65
4	Concrete Foundations	37,641.00	37,641.00	0.00	0.00	37,641.00	100.00	0.00	1,882.05
5	Concrete Flatwork	59,500.00	59,500.00	0.00	0.00	59,500.00	100.00	0.00	2,975.00
6	Masonry	57,550.00	57,550.00	0.00	0.00	57,550.00	100.00	0.00	2,877.50
7	Structural Steel	16,711.00	16,711.00	0.00	0.00	16,711.00	100.00	0.00	835.55
8	Rough Carpentry	67,391.00	67,391.00	0.00	0.00	67,391.00	100.00	0.00	3,369.55
9	Plastic Laminate Cabinets	20,364.00	20,364.00	0.00	0.00	20,364.00	100.00	0.00	1,018.20
10	Metal Roof & Wall Panels	80,046.00	80,046.00	0.00	0.00	80,046.00	100.00	0.00	4,002.30
11	Snow Retention	2,301.00	1,535.00	766.00	0.00	2,301.00	100.00	0.00	115.05
12	Joint Sealants	3,695.00	1,750.00	1,945.00	0.00	3,695.00	100.00	0.00	184.75
13	Door / Frames / Hardware	60,425.00	57,112.00	3,313.00	0.00	60,425.00	100.00	0.00	3,021.25
14	Sectional Doors	10,648.00	10,648.00	0.00	0.00	10,648.00	100.00	0.00	532.40
15	Aluminum Storefronts	23,327.00	23,327.00	0.00	0.00	23,327.00	100.00	0.00	1,166.35
16	Aluminum Windows	10,213.00	10,213.00	0.00	0.00	10,213.00	100.00	0.00	510.65
17	Metal Framing / Gypsum	206,280.00	206,280.00	0.00	0.00	206,280.00	100.00	0.00	10,314.00
18	Tiling	13,304.00	13,304.00	0.00	0.00	13,304.00	100.00	0.00	665.20
19	Acoustical Ceilings	8,800.00	8,800.00	0.00	0.00	8,800.00	100.00	0.00	440.00
20	Resilient Flooring / Carpet	31,850.00	0.00	31,850.00	0.00	31,850.00	100.00	0.00	1,592.50
21	Resinous Flooring	7,347.00	7,347.00	0.00	0.00	7,347.00	100.00	0.00	367.35

AIA Type Document
Application and Certification for Payment

TO (OWNER): City of Columbus
 2424 14th Street
 COLUMBUS, NE 68601

PROJECT: COLUMBUS FIRE STATION #2
 424 8th Street
 Columbus, NE 68601

APPLICATION NO: 13
PERIOD TO: 4/30/2023

DISTRIBUTION TO:
 _ OWNER
 _ ARCHITECT
 _ CONTRACTOR

FROM (CONTRACTOR): B-D Construction, Inc.
 2154 East 32nd Avenue
 Columbus, NE 68601

VIA (ARCHITECT): WSKF, Inc.
 110 Armour Road
 North Kansas City, MO 64116

ARCHITECT'S PROJECT NO: 20023

CONTRACT FOR: General Construction

CONTRACT DATE: 5/16/2022

ITEM	DESCRIPTION	SCHEDULE VALUE	PREVIOUS APPLICATIONS	COMPLETED THIS PERIOD	STORED MATERIAL	COMPLETED STORED	%	BALANCE	RETAINAGE
22	Painting	28,523.00	26,000.00	2,523.00	0.00	28,523.00	100.00	0.00	1,426.15
23	Signage	2,544.00	1,200.00	1,344.00	0.00	2,544.00	100.00	0.00	127.20
24	Wall Protection	741.00	0.00	741.00	0.00	741.00	100.00	0.00	37.05
25	Toilet Accessories	5,526.00	5,526.00	0.00	0.00	5,526.00	100.00	0.00	276.30
26	Turnout Gear Lockers	32,800.00	32,800.00	0.00	0.00	32,800.00	100.00	0.00	1,640.00
27	Metal Lockers	11,500.00	11,500.00	0.00	0.00	11,500.00	100.00	0.00	575.00
28	Roller Shades	2,680.00	0.00	2,680.00	0.00	2,680.00	100.00	0.00	134.00
29	Quartz Counters	7,700.00	0.00	7,700.00	0.00	7,700.00	100.00	0.00	385.00
30	Fire Sprinklers	4,500.00	4,500.00	0.00	0.00	4,500.00	100.00	0.00	225.00
31	Mechanical	345,450.00	345,450.00	0.00	0.00	345,450.00	100.00	0.00	17,272.50
32	Electrical	279,247.00	234,267.00	44,980.00	0.00	279,247.00	100.00	0.00	13,962.35
33	Earthwork	23,626.00	19,110.00	4,516.00	0.00	23,626.00	100.00	0.00	1,181.30
34	Turf and Irrigation	8,725.00	0.00	5,000.00	0.00	5,000.00	57.31	3,725.00	250.00
35	Fees	98,115.00	67,286.91	27,828.09	0.00	95,115.00	96.94	3,000.00	4,755.75
36	Insurance	1,445.00	1,280.00	165.00	0.00	1,445.00	100.00	0.00	72.25
37	Performance Bond	17,500.00	17,500.00	0.00	0.00	17,500.00	100.00	0.00	875.00
38	Alternate #1	37,782.00	37,782.00	0.00	0.00	37,782.00	100.00	0.00	1,889.10
39	Alternate #2	56,712.00	56,712.00	0.00	0.00	56,712.00	100.00	0.00	2,835.60
40	Change Order #1	110,279.38	100,248.65	10,030.73	0.00	110,279.38	100.00	0.00	5,513.97
REPORT TOTALS		\$1,912,773.38	\$1,742,462.08	\$163,586.30	\$0.00	\$1,906,048.38	99.65	\$6,725.00	\$95,302.42

PARTIAL WAIVER OF LIEN

To All Whom it May Concern:

WHEREAS, the undersigned has been engaged by B-D Construction, Inc.

to furnish labor and/or materials for work under contract for the improvement of the premises described as:

COLUMBUS FIRE STATION #2
424 8th Street

in the City / Village of COLUMBUS, State of NE

of which CITY OF COLUMBUS is the Owner.

NOW, THEREFORE, this 20th day of April 2023

for and in consideration of the sum of \$ 41,731.60 for invoice(s) 216696

Dollars paid simultaneously herewith, the receipt whereof is hereby acknowledged by the undersigned, the undersigned does hereby waive and release to the extent only of the aforesaid amount, any liens rights to, or claim of lien with respect to and on said above-described premises, and the improvements thereon, and on the monies or other considerations due or to become due from the Owner, by virtue of said contract, on account of labor, services, materials, fixtures, apparatus or machinery furnished by the undersigned to or for the above-described premises, but only to the extent of the payment aforesaid.

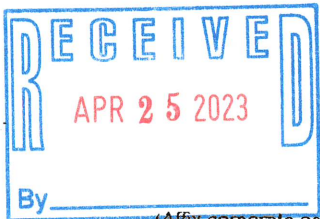

By _____ (Affix corporate seal here)

KIDWELL, INC (SEAL)

Mr. David
Vendor Signature (SEAL)

Title: Treasurer

Date: 4/25/2023

INSTRUCTIONS FOR PARTIAL WAIVER

- (A) Person or firm with whom you agreed to furnish either labor, or services, or materials, or both.
- (B) Fill in nature and extent of work; strike the word labor or the word materials if not in your contract.
- (C) If you have more than one contract on the same premises, describe the contract by number if available, date and extent of work.
- (D) Furnish an accurate enough description of the improvement and location of the premises so that it can be distinguished from any other property.
- (E) Amount shown should be the amount actually received on that date.
- (F) If a waiver is for a corporation, corporate name should be used, corporate seal affixed and the title of officer signing the waiver should be set forth; if waiver is for a partnership, the partnership name should be used, partner should sign and designate himself or herself as partner.

PARTIAL WAIVER OF LIEN

To All Whom it May Concern:

WHEREAS, the undersigned has been engaged by B-D Construction, Inc.

to furnish labor and/or materials for work under contract for the improvement of the premises described as:

COLUMBUS FIRE STATION #2

424 8th Street

in the City / Village of COLUMBUS, State of NE

of which CITY OF COLUMBUS is the Owner.

NOW, THEREFORE, this 20th day of April 2023

for and in consideration of the sum of \$ 7,696.55 for invoice(s) 1517

Dollars paid simultaneously herewith, the receipt whereof is hereby acknowledged by the undersigned, the undersigned does hereby waive and release to the extent only of the aforesaid amount, any liens rights to, or claim of lien with respect to and on said above-described premises, and the improvements thereon, and on the monies or other considerations due or to become due from the Owner, by virtue of said contract, on account of labor, services, materials, fixtures, apparatus or machinery furnished by the undersigned to or for the above-described premises, but only to the extent of the payment aforesaid.

LINCOLN EPOXY FLOORING



Vendor Signature

Title: OWNER

Date: 4-24-2023



INSTRUCTIONS FOR PARTIAL WAIVER

- (A) Person or firm with whom you agreed to furnish either labor, or services, or materials, or both.
- (B) Fill in nature and extent of work; strike the word labor or the word materials if not in your contract.
- (C) If you have more than one contract on the same premises, describe the contract by number if available, date and extent of work.
- (D) Furnish an accurate enough description of the improvement and location of the premises so that it can be distinguished from any other property.
- (E) Amount shown should be the amount actually received on that date.
- (F) If a waiver is for a corporation, corporate name should be used, corporate seal affixed and the title of officer signing the waiver should be set forth; if waiver is for a partnership, the partnership name should be used, partner should sign and designate himself or herself as partner.

PARTIAL WAIVER OF LIEN

To All Whom it May Concern:

WHEREAS, the undersigned has been engaged by B-D Construction, Inc.

to furnish labor and/or materials for work under contract for the improvement of the premises described as:

COLUMBUS FIRE STATION #2

424 8th Street

in the City / Village of COLUMBUS, State of NE

of which CITY OF COLUMBUS is the Owner.

NOW, THEREFORE, this 20th day of April 2023

for and in consideration of the sum of \$ 9,536.10 for invoice(s) 22900

Dollars paid simultaneously herewith, the receipt whereof is hereby acknowledged by the undersigned, the undersigned does hereby waive and release to the extent only of the aforesaid amount, any liens rights to, or claim of lien with respect to and on said above-described premises, and the improvements thereon, and on the monies or other considerations due or to become due from the Owner, by virtue of said contract, on account of labor, services, materials, fixtures, apparatus or machinery furnished by the undersigned to or for the above-described premises, but only to the extent of the payment aforesaid.

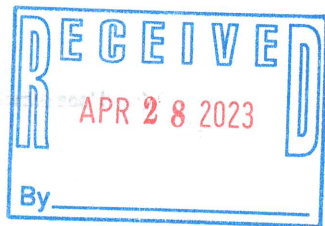

MIDWEST FLOOR COVERING INC. (SEAL)

[Handwritten Signature]
Vendor Signature (SIGNATURE)

Title: Treasurer

Date: 4-28-23

INSTRUCTIONS FOR PARTIAL WAIVER

- (A) Person or firm with whom you agreed to furnish either labor, or services, or materials, or both.
- (B) Fill in nature and extent of work; strike the word labor or the word materials if not in your contract.
- (C) If you have more than one contract on the same premises, describe the contract by number if available, date and extent of work.
- (D) Furnish an accurate enough description of the improvement and location of the premises so that it can be distinguished from any other property.
- (E) Amount shown should be the amount actually received on that date.
- (F) If a waiver is for a corporation, corporate name should be used, corporate seal affixed and the title of officer signing the waiver should be set forth; if waiver is for a partnership, the partnership name should be used, partner should sign and designate himself or herself as partner.

PARTIAL WAIVER OF LIEN

To All Whom it May Concern:

WHEREAS, the undersigned has been engaged by B-D Construction, Inc.

to furnish labor and/or materials for work under contract for the improvement of the premises described as:

COLUMBUS FIRE STATION #2
424 8th Street

in the City / Village of COLUMBUS, State of NE

of which CITY OF COLUMBUS is the Owner.

NOW, THEREFORE, this 20th day of April 2023

for and in consideration of the sum of \$ 4,740.50 for invoice(s) 22024-6

Dollars paid simultaneously herewith, the receipt whereof is hereby acknowledged by the undersigned, the undersigned does hereby waive and release to the extent only of the aforesaid amount, any liens rights to, or claim of lien with respect to and on said above-described premises, and the improvements thereon, and on the monies or other considerations due or to become due from the Owner, by virtue of said contract, on account of labor, services, materials, fixtures, apparatus or machinery furnished by the undersigned to or for the above-described premises, but only to the extent of the payment aforesaid.

(Affix corporate seal here)

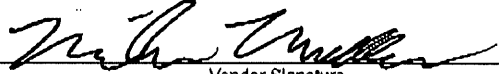
MUELLER & SCHOEPF DRYWALL INC. (SEAL)
 (SEAL)
Vendor Signature

Title: Treasurer

Date: 4/24/23

INSTRUCTIONS FOR PARTIAL WAIVER

- (A) Person or firm with whom you agreed to furnish either labor, or services, or materials, or both.
- (B) Fill in nature and extent of work; strike the word labor or the word materials if not in your contract.
- (C) If you have more than one contract on the same premises, describe the contract by number if available, date and extent of work.
- (D) Furnish an accurate enough description of the improvement and location of the premises so that it can be distinguished from any other property.
- (E) Amount shown should be the amount actually received on that date.
- (F) If a waiver is for a corporation, corporate name should be used, corporate seal affixed and the title of officer signing the waiver should be set forth; if waiver is for a partnership, the partnership name should be used, partner should sign and designate himself or herself as partner.

PARTIAL WAIVER OF LIEN



To All Whom it May Concern:

WHEREAS, the undersigned has been engaged by B-D Construction, Inc.

to furnish labor and/or materials for work under contract for the improvement of the premises described as:

COLUMBUS FIRE STATION #2
424 8th Street

in the City / Village of COLUMBUS, State of NE

of which CITY OF COLUMBUS is the Owner.

NOW, THEREFORE, this 20th day of April 2023

for and in consideration of the sum of \$ 136,329.75 for invoice(s) 22024-7, 22024-8

Dollars paid simultaneously herewith, the receipt whereof is hereby acknowledged by the undersigned, the undersigned does hereby waive and release to the extent only of the aforesaid amount, any liens rights to, or claim of lien with respect to and on said above-described premises, and the improvements thereon, and on the monies or other considerations due or to become due from the Owner, by virtue of said contract, on account of labor, services, materials, fixtures, apparatus or machinery furnished by the undersigned to or for the above-described premises, but only to the extent of the payment aforesaid.

(Affix corporate seal here)

OBRIST & CO. INC.

Handwritten signature and Vendor Signature label.

Title: Owner

Date: 4-25-23

INSTRUCTIONS FOR PARTIAL WAIVER

- (A) Person or firm with whom you agreed to furnish either labor, or services, or materials, or both.
(B) Fill in nature and extent of work; strike the word labor or the word materials if not in your contract.
(C) If you have more than one contract on the same premises, describe the contract by number if available, date and extent of work.
(D) Furnish an accurate enough description of the improvement and location of the premises so that it can be distinguished from any other property.
(E) Amount shown should be the amount actually received on that date.
(F) If a waiver is for a corporation, corporate name should be used, corporate seal affixed and the title of officer signing the waiver should be set forth; if waiver is for a partnership, the partnership name should be used, partner should sign and designate himself or herself as partner.

PARTIAL WAIVER OF LIEN

To All Whom it May Concern:

WHEREAS, the undersigned has been engaged by B-D Construction, Inc.

to furnish labor and/or materials for work under contract for the improvement of the premises described as:

COLUMBUS FIRE STATION #2
424 8th Street

in the City / Village of COLUMBUS, State of NE

of which CITY OF COLUMBUS is the Owner.

NOW, THEREFORE, this 20th day of April 2023

for and in consideration of the sum of \$ 8,284.00 for invoice(s) 22024-1

Dollars paid simultaneously herewith, the receipt whereof is hereby acknowledged by the undersigned, the undersigned does hereby waive and release to the extent only of the aforesaid amount, any liens rights to, or claim of lien with respect to and on said above-described premises, and the improvements thereon, and on the monies or other considerations due or to become due from the Owner, by virtue of said contract, on account of labor, services, materials, fixtures, apparatus or machinery furnished by the undersigned to or for the above-described premises, but only to the extent of the payment aforesaid.

(Affix corporate seal here)

STEPHENS & SMITH CONSTRUCTION (SEAL)

[Signature] (SEAL)
Vendor Signature

Title: V.P. S.P.D.

Date: 4-26-2023

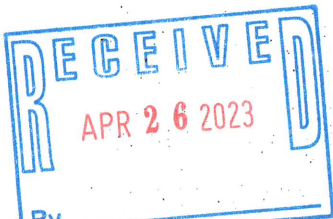

INSTRUCTIONS FOR PARTIAL WAIVER

- (A) Person or firm with whom you agreed to furnish either labor, or services, or materials, or both.
- (B) Fill in nature and extent of work; strike the word labor or the word materials if not in your contract.
- (C) If you have more than one contract on the same premises, describe the contract by number if available, date and extent of work.
- (D) Furnish an accurate enough description of the improvement and location of the premises so that it can be distinguished from any other property.
- (E) Amount shown should be the amount actually received on that date.
- (F) If a waiver is for a corporation, corporate name should be used, corporate seal affixed and the title of officer signing the waiver should be set forth; if waiver is for a partnership, the partnership name should be used, partner should sign and designate himself or herself as partner.

PARTIAL WAIVER OF LIEN

10572

To All Whom it May Concern:

WHEREAS, the undersigned has been engaged by B-D Construction, Inc.

to furnish labor and/or materials for work under contract for the improvement of the premises described as:

COLUMBUS FIRE STATION #2

424 8th Street

in the City / Village of COLUMBUS, State of NE

of which CITY OF COLUMBUS is the Owner.

NOW, THEREFORE, this 20th day of April 2023

for and in consideration of the sum of \$ 5,747.50 for invoice(s) 22024-3

Dollars paid simultaneously herewith, the receipt whereof is hereby acknowledged by the undersigned, the undersigned does hereby waive and release to the extent only of the aforesaid amount, any liens rights to, or claim of lien with respect to and on said above-described premises, and the improvements thereon, and on the monies or other considerations due or to become due from the Owner, by virtue of said contract, on account of labor, services, materials, fixtures, apparatus or machinery furnished by the undersigned to or for the above-described premises, but only to the extent of the payment aforesaid.

(Affix corporate seal here)

STORAGE & DESIGN GROUP (SEAL)

Craig Dittmer Vendor Signature (SEAL)

Title: VP Sales/GM

Date: 4-24-23

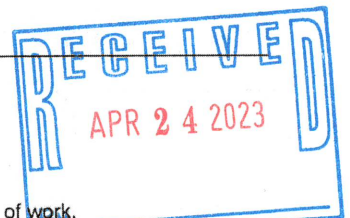

INSTRUCTIONS FOR PARTIAL WAIVER

- (A) Person or firm with whom you agreed to furnish either labor, or services, or materials, or both.
(B) Fill in nature and extent of work; strike the word labor or the word materials if not in your contract.
(C) If you have more than one contract on the same premises, describe the contract by number if available, date and extent of work.
(D) Furnish an accurate enough description of the improvement and location of the premises so that it can be distinguished from any other property.
(E) Amount shown should be the amount actually received on that date.
(F) If a waiver is for a corporation, corporate name should be used, corporate seal affixed and the title of officer signing the waiver should be set forth; if waiver is for a partnership, the partnership name should be used, partner should sign and designate himself or herself as partner.

PARTIAL WAIVER OF LIEN

To All Whom it May Concern:

WHEREAS, the undersigned has been engaged by B-D Construction, Inc.

to furnish labor and/or materials for work under contract for the improvement of the premises described as:

COLUMBUS FIRE STATION #2

424 8th Street

in the City / Village of COLUMBUS, State of NE

of which CITY OF COLUMBUS is the Owner.

NOW, THEREFORE, this 24th day of March 2023

for and in consideration of the sum of \$ 37,698.85 for invoice(s) 214676

Dollars paid simultaneously herewith, the receipt whereof is hereby acknowledged by the undersigned, the undersigned does hereby waive and release to the extent only of the aforesaid amount, any liens rights to, or claim of lien with respect to and on said above-described premises, and the improvements thereon, and on the monies or other considerations due or to become due from the Owner, by virtue of said contract, on account of labor, services, materials, fixtures, apparatus or machinery furnished by the undersigned to or for the above-described premises, but only to the extent of the payment aforesaid.

(Affix corporate seal here)

KIDWELL, INC (SEAL)

[Signature] (SEAL)
Vendor Signature

Title: Treasurer

Date: 3-27-2023

INSTRUCTIONS FOR PARTIAL WAIVER

- (A) Person or firm with whom you agreed to furnish either labor, or services, or materials, or both.
- (B) Fill in nature and extent of work; strike the word labor or the word materials if not in your contract.
- (C) If you have more than one contract on the same premises, describe the contract by number if available, date and extent of work.
- (D) Furnish an accurate enough description of the improvement and location of the premises so that it can be distinguished from any other property.
- (E) Amount shown should be the amount actually received on that date.
- (F) If a waiver is for a corporation, corporate name should be used, corporate seal affixed and the title of officer signing the waiver should be set forth; if waiver is for a partnership, the partnership name should be used, partner should sign and designate himself or herself as partner.

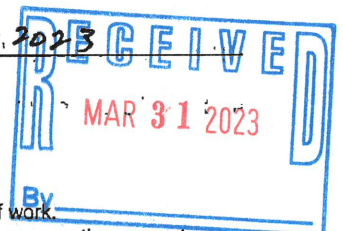

PARTIAL WAIVER OF LIEN

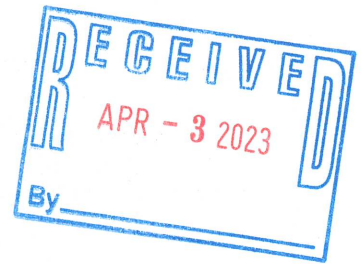

To All Whom it May Concern:

WHEREAS, the undersigned has been engaged by B-D Construction, Inc.

to furnish labor and/or materials for work under contract for the improvement of the premises described as:

COLUMBUS FIRE STATION #2
424 8th Street

in the City / Village of COLUMBUS, State of NE

of which CITY OF COLUMBUS is the Owner.

NOW, THEREFORE, this 24th day of March 2023

for and in consideration of the sum of \$ 46,245.52 for invoice(s) 22024-1

Dollars paid simultaneously herewith, the receipt whereof is hereby acknowledged by the undersigned, the undersigned does hereby waive and release to the extent only of the aforesaid amount, any liens rights to, or claim of lien with respect to and on said above-described premises, and the improvements thereon, and on the monies or other considerations due or to become due from the Owner, by virtue of said contract, on account of labor, services, materials, fixtures, apparatus or machinery furnished by the undersigned to or for the above-described premises, but only to the extent of the payment aforesaid.



WARREN GARAGE DOOR INC. (SEAL)

Carolyn Warren Vendor Signature (SEAL)

Title: Vice President

Date: 4-3-23

INSTRUCTIONS FOR PARTIAL WAIVER

- (A) Person or firm with whom you agreed to furnish either labor, or services, or materials, or both.
(B) Fill in nature and extent of work; strike the word labor or the word materials if not in your contract.
(C) If you have more than one contract on the same premises, describe the contract by number if available, date and extent of work.
(D) Furnish an accurate enough description of the improvement and location of the premises so that it can be distinguished from any other property.
(E) Amount shown should be the amount actually received on that date.
(F) If a waiver is for a corporation, corporate name should be used, corporate seal affixed and the title of officer signing the waiver should be set forth; if waiver is for a partnership, the partnership name should be used, partner should sign and designate himself or herself as partner.

APPLICATION AND CERTIFICATION FOR PAYMENT

AIA DOCUMENT G702

PAGE ONE OF 2 PAGES

TO CONTRACTOR: PROJECT: City of Columbus
 Kirkham, Michael, & Associates, Inc. Airport Hangar
 5621 Northwest 1st Street Suite 400
 Lincoln, NE 68521

FROM SUBCONTRACTOR: VIA ARCHITECT:
 Platte Valley Precast
 2670 54th Ave.
 Columbus, Nebraska 68601

APPLICATION NO: 1
 PERIOD TO: 5/31/2023
 PROJECT NOS:

Distribution to:
 OWNER
 ARCHITECT
 CONTRACTOR

CONTRACT FOR:

CONTRACT DATE:

SUBCONTRACTOR'S APPLICATION FOR PAYMENT

Application is made for payment, as shown below, in connection with the Contract. Continuation Sheet, AIA Document G703, is attached.

1. ORIGINAL CONTRACT SUM	\$	49,455.50
2. Net change by Change Orders	\$	0.00
3. CONTRACT SUM TO DATE (Line 1 ± 2)	\$	49,455.50
4. TOTAL COMPLETED & STORED TO DATE (Column G on G703)	\$	47,955.50
5. RETAINAGE:		
a. 10% of Completed Work (Column D + E on G703)	\$	4,795.55
b. 10% of Stored Material (Column F on G703)	\$	
Total Retainage (Lines 5a + 5b or Total in Column I of G703)	\$	4,795.55
6. TOTAL EARNED LESS RETAINAGE (Line 4 Less Line 5 Total)	\$	43,159.95
7. LESS PREVIOUS CERTIFICATES FOR PAYMENT (Line 6 from prior Certificate)	\$	0.00
8. CURRENT PAYMENT DUE	\$	43,159.95
9. BALANCE TO FINISH, INCLUDING RETAINAGE (Line 3 less Line 6)	\$	6,295.55

CHANGE ORDER SUMMARY	ADDITIONS	DEDUCTIONS
Total changes approved in previous months by Owner		
Total approved this Month		
TOTALS		
NET CHANGES by Change Order		

The undersigned Contractor certifies that to the best of the Contractor's knowledge, information and belief the Work covered by this Application for Payment has been completed in accordance with the Contract Documents, that all amounts have been paid by the Contractor for Work for which previous Certificates for Payment were issued and payments received from the Owner, and that current payment shown herein is now due.

SUBCONTRACTOR:

By: Sherril Steuring Date: 5-19-23

State of: Nebraska County of: Platte
 Subscribed and sworn to before me this 19 day of May 2023
 Notary Public: Lynita R Gehring
 My Commission expires: Feb 06, 2026



CONTRACTOR'S CERTIFICATE FOR PAYMENT

In accordance with the Contract Documents, based on on-site observations and the data comprising the application, the Architect certifies to the Owner that to the best of the Architect's knowledge, information and belief the Work has progressed as indicated, the quality of the Work is in accordance with the Contract Documents, and the Contractor is entitled to payment of the AMOUNT CERTIFIED.

AMOUNT CERTIFIED \$ \$43,159.95

(Attach explanation if amount certified differs from the amount applied. Initial all figures on this Application and on the Continuation Sheet that are changed to conform with the amount certified.)

ARCHITECT: [Signature] Date: 5/25/23

This Certificate is not negotiable. The AMOUNT CERTIFIED is payable only to the Contractor named herein. Issuance, payment and acceptance of payment are without prejudice to any rights of the Owner or Contractor under this Contract.

Richard J. Bogue 5-26-2023

CONTINUATION SHEET

AIA DOCUMENT G703

PAGE 2 OF 2 PAGES

AIA Document G702, APPLICATION AND CERTIFICATION FOR PAYMENT, containing

Contractor's signed certification is attached.

In tabulations below, amounts are stated to the nearest dollar.

Use Column I on Contracts where variable retainage for line items may apply.

APPLICATION NO: 1

APPLICATION DATE: 5/20/2023

PERIOD TO: 5/31/2023

CONTRACTOR'S PROJECT NO:

A ITEM NO.	B DESCRIPTION OF WORK	C SCHEDULED VALUE	D WORK COMPLETED		F MATERIALS PRESENTLY STORED (NOT IN D OR E)	G		H BALANCE TO FINISH (C - G)	I RETAINAGE (IF VARIABLE RATE) 10%
			FROM PREVIOUS APPLICATION (D + E)	THIS PERIOD		TOTAL COMPLETED AND STORED TO DATE (D+E+F)	% (G ÷ C)		
1	Mobilization	\$3,500.00		\$3,500.00		\$3,500.00	100%	\$0.00	\$350.00
2	Existing Pavement Removal	\$5,548.00		\$5,548.00		\$5,548.00	100%	\$0.00	\$554.80
3	Existing Pavement Removal Hangar Floor	\$4,812.50		\$4,812.50		\$4,812.50	100%	\$0.00	\$481.25
4	12-Inch Compacted Subgrade	\$12,465.00		\$12,465.00		\$12,465.00	100%	\$0.00	\$1,246.50
5	6-Inch PCC NDOT-47B-4000	\$9,880.00		\$9,380.00		\$9,380.00	95%	\$500.00	\$938.00
6	6-Inch PCC Hangar Floor	\$13,250.00		\$12,250.00		\$12,250.00	92%	\$1,000.00	\$1,225.00
7									
8									
9									
10									
11									
12									
13									
14									
15									
16									
17									
18									
19									
20									
21									
22									
23									
24									
25									
26									
27									
GRAND TOTALS		\$49,455.50	\$0.00	\$47,955.50	\$0.00	\$47,955.50	97%	\$1,500.00	\$4,795.55



Contractor's Application and Certificate of Payment

200-200-57200-23025 - 431,078.92
 200-200-57300-20071 - 382,277.54

	Contractor's Application for Payment No:	5
	Application Period: (From - to)	5/2/23 to 5/23/23
To: City of Columbus (Owner)	From (Contractor): Gehring Construction and Ready Mix Co., Inc.	Contractor's Project No.:
Project Name: SID No. 189 48th Ave. from 23rd St. to S. of Bradshaw Park Entrance & Concrete Paving Improvements 2023		Via (Consulting Engineer / Architect): City of Columbus
Fiscal Year Budget Number: 200-200-57200-23025 & 200-200-57300-20071		

Application For Payment

Field Order and Change Order Summary

Field (FO#) and Change Orders (CO#) Approved:		
Number	Additions	Deductions
FO1	\$ 16,120.00	
FO2	\$ 10,343.00	
TOTALS	\$ 26,463.00	\$ -
NET CHANGE	\$ 26,463.00	

1. ORIGINAL CONTRACT PRICE.....	\$	3,613,722.25
2. Net change by Field Order and Change Orders.....	\$	26,463.00
3. Current Contract Price (Line 1 ± 2).....	\$	3,640,185.25
4. TOTAL COMPLETED AND STORED TO DATE (Column H on Progress Estimate).....	\$	1,640,519.00
5. RETAINAGE: (Capped at 10% at 50% of Line 3) (When line 4 is over 50% of Line 3 do calculation of Line 3 x .5 x .1 to get Retainage)	\$	164,051.90
6. AMOUNT ELIGIBLE TO DATE (Line 4 - Line 5).....	\$	1,476,467.10
7. LESS PREVIOUS PAYMENTS (Line 6 from prior Application).....	\$	663,110.64
8. AMOUNT DUE THIS APPLICATION (Line 6 - Line 7).....	\$	813,356.46
9. BALANCE TO FINISH, PLUS RETAINAGE (Line 3- Line 6).....	\$	2,163,718.15

(To double check Line 9 Take Column I + Line 5 should = Line 9 calculations)

Contractor's Certification	
<p>The undersigned Contractor certifies that to the best of the Contractor's knowledge, information and belief, the Work covered by this Application for Payment has been completed in accordance with the Contract Documents, that all amounts have been paid by the Contractor for Work for which previous Certificates for Payment were issued and payments received from the Owner, and that current payment shown herein is now due.</p>	
<p>Contractor: Gehring Construction & Ready Mix Co., Inc.</p>	
<p>By: <u>Stephen Anderson</u></p>	<p>Date: <u>5-23-23</u></p>
<p>Printed/Typed Name: Stephen Anderson</p>	

Payment of:	<p>(Line 8 or other - attach explanation of the other amount)</p>
is recommended by:	<p>(Consulting Engineer/Architect) (Date)</p>
Payment of:	<p>\$ 813,356.46</p>
is approved by:	<p>(Line 8 or other - attach explanation of the other amount) <u>Richard J. Bogue</u> 5-23-2023 (City Engineer) (Date)</p>
Approved by:	<p>Funding Agency (if applicable) (Date)</p>

APPLICATION AND CERTIFICATE FOR PAYMENT

Containing Contractor's signed Certification is attached

Project Name: SID No. 189 48th Ave. from 23rd St. to S. of Bradshaw Park Entrance & Concrete Paving Improvements 2023				Contractor's Pay Application: 5							
Application Period: (From - To) 5/2/23 to 5/23/23											
A		B	C	D	E	F	G	H		I	
Item											
Bid Item No.	Description	Unit of Measure	Bid Quantity	Unit Price	Bid Value (D*E)	Estimated Quantity Installed	Value Installed (G*E)	Material Presently Stored	Total Completed and Stored to Date (F+G)	% (F) B (H/F*100)	Balance to Finish (D - H)
PROJECT A: SID NO. 189 48 Ave. from 23 St. to S Bradshaw Park Entrance (CIP 23-25)											
1	Mobilization	JOB	1	\$ 75,000.00	\$ 75,000.00	0.06	\$ 4,500.00		\$ 4,500.00	6	\$ 70,500.00
2	Traffic & Pedestrian Control, including Detour	JOB	1	\$ 10,000.00	\$ 10,000.00	0.15	\$ 1,500.00		\$ 1,500.00	15	\$ 8,500.00
3	NPDES, SWPPP, & BMP Maintenance	JOB	1	\$ 8,000.00	\$ 8,000.00	0.50	\$ 4,000.00		\$ 4,000.00	50	\$ 4,000.00
4	Curb or Grate Inlet Filter BMP	EA	20	\$ 200.00	\$ 4,000.00		\$ -		\$ -	0	\$ 4,000.00
5	Remove & Mill Asphalt Paving	SY	6,704	\$ 8.00	\$ 53,632.00	6,928	\$ 55,424.00		\$ 55,424.00	103	\$ (1,792.00)
6	Remove Concrete Paving	SY	1,496	\$ 16.00	\$ 23,936.00	1,704	\$ 27,264.00		\$ 27,264.00	114	\$ (3,328.00)
7	Remove Culvert All Sizes Including Headwalls & FES	LF	350	\$ 12.00	\$ 4,200.00	313	\$ 3,756.00		\$ 3,756.00	89	\$ 444.00
8	Remove Inlet	EA	2	\$ 1,000.00	\$ 2,000.00		\$ -		\$ -	0	\$ 2,000.00
9	Remove Junction Box	EA	1	\$ 1,500.00	\$ 1,500.00		\$ -		\$ -	0	\$ 1,500.00
10	Remove & Reset Stop Sign	EA	2	\$ 300.00	\$ 600.00		\$ -		\$ -	0	\$ 600.00
11	Temporary Road Surfacing and Maintenance	JOB	1	\$ 50,000.00	\$ 50,000.00	0.57	\$ 28,500.00		\$ 28,500.00	57	\$ 21,500.00
12	Remove Concrete Header	LF	33	\$ 25.00	\$ 825.00		\$ -		\$ -	0	\$ 825.00
13	9-inch P.C. Concrete with 1 1/4" Doweled Paving NDOT Type 47B-3500	SY	9,460	\$ 65.00	\$ 614,900.00	4,525	\$ 294,125.00		\$ 294,125.00	47.833	\$ 320,775.00
14	8-inch P.C. Concrete Driveway Paving NDOT Type 47B-3500	SY	47	\$ 65.00	\$ 3,055.00		\$ -		\$ -	0	\$ 3,055.00
15	6-inch P.C. Concrete Street Paving NDOT Type 47B-3500	SY	504	\$ 60.00	\$ 30,240.00		\$ -		\$ -	0	\$ 30,240.00
16	6-inch P.C. Concrete Trail Paving, including Handicap Ramps, NDOT Type 47B-3500	SY	1,696	\$ 60.00	\$ 101,760.00		\$ -		\$ -	0	\$ 101,760.00
17	6-inch P.C. Concrete Driveway Paving, NDOT Type 47B-3500	SY	601	\$ 60.00	\$ 36,060.00	236	\$ 14,160.00		\$ 14,160.00	39.268	\$ 21,900.00
18	5-inch P.C. Concrete Sidewalk Paving, NDOT Type 47B-3500	SY	335	\$ 75.00	\$ 25,125.00	11	\$ 825.00		\$ 825.00	3.2836	\$ 24,300.00
19	9-inch P.C. Concrete Street Paving, NDOT Type 47B-3500	SY	353	\$ 65.00	\$ 22,945.00		\$ -		\$ -	0	\$ 22,945.00
20	1.5 Foot Concrete Header	LF	105	\$ 20.00	\$ 2,100.00		\$ -		\$ -	0	\$ 2,100.00
21	ADA Handicap Ramp Detectable Warning Panel	SF	216	\$ 38.00	\$ 8,208.00	20	\$ 760.00		\$ 760.00	9.2593	\$ 7,448.00
22	4-inch Aggregate Paving Subbase	SY	11,142	\$ 16.00	\$ 178,272.00	4,525	\$ 72,400.00		\$ 72,400.00	40.612	\$ 105,872.00
23	Underdrain System, including 4-inch Perforated PVC Pipe, Rock, Fabric, Complete in Place	LF	4,780	\$ 14.00	\$ 66,920.00	1,844	\$ 25,816.00		\$ 25,816.00	38.577	\$ 41,104.00
24	Adjust Manhole to Grade	EA	6	\$ 1,000.00	\$ 6,000.00	2	\$ 2,000.00		\$ 2,000.00	33.333	\$ 4,000.00
25	Adjust Water Valve Box to Grade	EA	6	\$ 1,000.00	\$ 6,000.00	1	\$ 1,000.00		\$ 1,000.00	16.667	\$ 5,000.00
26	Monument Well	EA	1	\$ 1,000.00	\$ 1,000.00		\$ -		\$ -	0	\$ 1,000.00
TOTAL PAGE ONE (ITEMS 1-26)					\$ 1,336,278.00		\$ 536,030.00	\$ -	\$ 536,030.00		\$ 800,248.00

Project SID No. 189 48th Ave. from 23rd St. to S. of Bradshaw Park Entrance & Name: Concrete Paving Improvements 2023					Contractor's Pay Application: 5						
Application Period: (From - To) 5/2/23 to 5/23/23											
A			B	C	D	E	F	G	H		I
Item			Bid Quantity	Unit Price	Bid Value (D*E)	Estimated Quantity Installed	Value Installed (G*E)	Material Presently Stored	Total Completed and Stored to Date (F+G)	% (F) B (H/F*100)	Balance to Finish (D - H)
Bid Item No.	Description	Unit of Measure									
PROJECT C: 36th Street from 48th to 50th Avenue (CIP 20-71)											
1	Mobilization	JOB	1	\$ 7,500.00	\$ 7,500.00	1	\$ 7,500.00		\$ 7,500.00	100	\$ -
2	Traffic & Pedestrian Control	JOB	1	\$ 5,000.00	\$ 5,000.00	1	\$ 5,000.00		\$ 5,000.00	100	\$ -
3	Curb or Grate Inlet Filter BMP	EA	6	\$ 300.00	\$ 1,800.00	6	\$ 1,800.00		\$ 1,800.00	100	\$ -
4	Remove Paving, including Sawing	SY	3,997	\$ 18.00	\$ 71,946.00	4,028	\$ 72,504.00		\$ 72,504.00	101	\$ (558.00)
5	Remove & Rebuild Inlet (and 3 Junction Boxes)	EA	6	\$ 4,500.00	\$ 27,000.00	9	\$ 40,500.00		\$ 40,500.00	150	\$ (13,500.00)
6	Remove & Reset Mailbox	EA	4	\$ 600.00	\$ 2,400.00	7	\$ 4,200.00		\$ 4,200.00	175	\$ (1,800.00)
7	Temporary Aggregate Surfacing Driveways (Sidewalks west end and 12" RCP pipe)	JOB	1	\$ 10,000.00	\$ 10,000.00	1	\$ 10,000.00		\$ 10,000.00	100	\$ -
8	7-inch P.C. Concrete Paving, NDOT Type 47B-3500	SY	3,758	\$ 66.00	\$ 248,028.00	3,786	\$ 249,876.00		\$ 249,876.00	101	\$ (1,848.00)
9	6-inch P.C. Concrete Driveway Paving NDOT Type 47B-3500	SY	239	\$ 66.00	\$ 15,774.00	242	\$ 15,972.00		\$ 15,972.00	101	\$ (198.00)
10	Adjust Manhole to Grade (1 Valve Box)	EA	3	\$ 1,000.00	\$ 3,000.00	0.75	\$ 750.00		\$ 750.00	25	\$ 2,250.00
11	Over Excavation & Crushed Concrete	TON	50	\$ 75.00	\$ 3,750.00		\$ -		\$ -	0	\$ 3,750.00
12	Earthwork, Final Grading, Backfilling, & Shaping	JOB	1	\$ 20,000.00	\$ 20,000.00	0.50	\$ 10,000.00		\$ 10,000.00	50	\$ 10,000.00
13	Sodding, Watering, & Maintenance	SF	12,192	\$ 2.75	\$ 33,528.00		\$ -		\$ -	0	\$ 33,528.00
GRAND TOTAL PROJECT C (ITEMS 1-13)					\$ 449,726.00		\$ 418,102.00		\$ 418,102.00		\$ 31,624.00
ADDITIONAL PROJECT NO. 1: 40th Avenue from 27th Street to the North (CIP 20-71)											
1	Mobilization	JOB	1	\$ 7,500.00	\$ 7,500.00	1	\$ 7,500.00		\$ 7,500.00	100	\$ -
2	Traffic & Pedestrian Control	JOB	1	\$ 5,000.00	\$ 5,000.00	1	\$ 5,000.00		\$ 5,000.00	100	\$ -
3	Curb or Grate Inlet Filter BMP	EA	4	\$ 300.00	\$ 1,200.00		\$ -		\$ -	0	\$ 1,200.00
4	Remove Paving, including Sawing	SY	2,600	\$ 18.00	\$ 46,800.00	2,592	\$ 46,656.00		\$ 46,656.00	100	\$ 144.00
5	Remove & Reset Mailbox	EA	12	\$ 600.00	\$ 7,200.00	1	\$ 600.00		\$ 600.00	8	\$ 6,600.00
6	Temporary Aggregate Surfacing Driveways (sidewalks, repair of inlet, 2025 casting)	JOB	1	\$ 10,000.00	\$ 10,000.00	0.460	\$ 4,600.00		\$ 4,600.00	46	\$ 5,400.00
7	7-inch P.C. Concrete Paving, NDOT Type 47B-3500	SY	2,372	\$ 70.00	\$ 166,040.00	2,372	\$ 166,040.00		\$ 166,040.00	100	\$ -
8	6-inch P.C. Concrete Driveway Paving NDOT Type 47B-3500	SY	220	\$ 70.00	\$ 15,400.00	220	\$ 15,400.00		\$ 15,400.00	100	\$ -
9	Adjust Manhole to Grade	EA	2	\$ 1,000.00	\$ 2,000.00	2	\$ 2,000.00		\$ 2,000.00	100	\$ -
10	Over Excavation & Crushed Concrete	TON	50	\$ 75.00	\$ 3,750.00	622	\$ 46,650.00		\$ 46,650.00	1244	\$ (42,900.00)
11	Earthwork, Final Grading, Backfilling, & Shaping	JOB	1	\$ 10,000.00	\$ 10,000.00	1	\$ 10,000.00		\$ 10,000.00	100	\$ -
12	Sodding, Watering, & Maintenance	SF	7,712	\$ 2.75	\$ 21,208.00	2,800	\$ 7,700.00		\$ 7,700.00	36	\$ 13,508.00
GRAND TOTAL ADDITIONAL PROJECT NO. 1 (ITEMS 1-12)					\$ 296,098.00		\$ 312,146.00		\$ 312,146.00		\$ (16,048.00)
GRAND TOTAL PROJECTS A, B, C, & ADDITIONAL PROJECT NO. 1					\$ 3,613,722.25		\$ 1,640,519.00		\$ 1,640,519.00		\$ 1,973,203.25

4.I. Payroll and bills on file.

Vendor Code Post Date	Vendor Name Activity	Inv/Check #	Description	Invoice Amt	Check Amt
10512 06/06/2023	10 COUNTY TITLE & ESCROW INC. INVOICE	19-DTR-101	CDBG MATCH	3,234.21	
			Total:	3,234.21	
			Net of 1 Invoices / 0 Checks	3,234.21	
02359 06/06/2023	911 CUSTOM LLC INVOICE	52611	BLACKINGTON FLEX BADGE #38 - ROMSHEK QM	51.00	
06/06/2023	INVOICE	52606	SURVIVAL ARMOR FRONT OPENING RAID CARRIER -	308.00	
06/06/2023	INVOICE	52610	BLACKINGTON FLEX BADGE #6 - STRECKER QM	51.00	
06/06/2023	INVOICE	52609	BLACKINGTON FLEX BADGE - HAYNES QM	51.00	
			Total:	461.00	
			Net of 4 Invoices / 0 Checks	461.00	
00116 06/06/2023	ACE HARDWARE & GARDEN CNT INVOICE	194049/5	KEY MASTER	8.37	
06/06/2023	INVOICE	194048/5	NUTS, BOLTS, SCREWS	1.22	
06/06/2023	INVOICE	194091/5	RED MULCH	32.94	
06/06/2023	INVOICE	194092/5	ELASTOSTART ROPE	4.99	
06/06/2023	INVOICE	194112/5	PUSH THREAD ADAPTER	9.98	
06/06/2023	INVOICE	194113/5	GARDEN SPADE	12.97	
06/06/2023	INVOICE	194105/5	KEY SCHLAGE	2.79	
06/06/2023	INVOICE	194120/5	COUPLE 1/2", ELBOW,ADAPTER, PLUMBING SUPPLE:	7.55	
06/06/2023	INVOICE	194127/5	EDGER BLADE	10.99	
06/06/2023	INVOICE	194118/5	WIRE & WIRING SUPPLIES, ANTI-SHORT BUSHING	17.63	
06/06/2023	INVOICE	194193/5	RUST STOP SPRAY PAINT	35.99	
06/06/2023	INVOICE	193856/5	2 CYCLE OIL	21.54	
06/06/2023	INVOICE	193843/5	SIDEWALK CHALK	5.98	
06/06/2023	INVOICE	193837/5	CNTRHOSE, EZ SEED SUN & SHADE	122.98	
06/06/2023	INVOICE	193940/5	KEY KWIKSET, NUTS, BOLTS, WASHER, O-RING	7.26	
06/06/2023	INVOICE	193935/5	AIR FILTER	20.97	
06/06/2023	INVOICE	193891/5	PIK STIK REACHER, SAFETY GLASSES	32.98	
06/06/2023	INVOICE	193877/5	HOSE MENDER, WALL MOUNT HOSE HANGER	26.58	
06/06/2023	INVOICE	193873/5	PAINT ROLLER, PORCH/FLOOR SLT GRAY	64.48	
06/06/2023	INVOICE	193872/5	ENGRAVER ELECTRIC	7.97	
06/06/2023	INVOICE	193862/5	KEY KWIKSET, KEY MASTER	39.06	
06/06/2023	INVOICE	193855/5	FUSE PLUG	10.99	
06/06/2023	INVOICE	193977/5	AJAX CLEANER	10.75	
06/06/2023	INVOICE	193984/5	NUTS, BOLTS, SCREWS, FIXED EYE QUICK SNAP, 1	64.25	
06/06/2023	INVOICE	193954/5	DIAPHRAGM SLOAN	9.99	
06/06/2023	INVOICE	193943/5	KEY SCHLAGE	2.59	
06/06/2023	INVOICE	193989/5	2" RGD 2H STRAP, DRILL BIT	22.55	
06/06/2023	INVOICE	194029/5	RGD 2H STRAP	3.96	
06/06/2023	INVOICE	194026/5	ELEMENT 4500W	4.00	
06/06/2023	INVOICE	194021/5	TAPE	9.00	
06/06/2023	INVOICE	194011/5	ELEMENT 4500W, SNAP QUICK	29.35	
06/06/2023	INVOICE	193738/5	KEY MASTER	11.16	
06/06/2023	INVOICE	193756/5	SPRAY PAINT	15.98	
06/06/2023	INVOICE	194332/5	GARDEN SPRAYER, FOLDING BUFFET TABLE	139.97	
06/06/2023	INVOICE	194215/5	RISER, CUT-OFF RISER, BUSHING	19.08	
06/06/2023	INVOICE	194244/5	COUPLING 1/4"	5.59	
06/06/2023	INVOICE	194265/5	PIK STIK	49.98	
06/06/2023	INVOICE	194268/5	DUCT TAPE	17.98	
06/06/2023	INVOICE	194272/5	RESP HALF FACE, GRAPHITE DRY SPRAY, RESP CAI	62.14	
06/06/2023	INVOICE	194244/5	NUTS, BOLTS, SCREWS	15.96	
06/06/2023	INVOICE	194281/5	GATORLINE, STARTER ASSY	106.98	

Vendor Code Post Date	Vendor Name Activity	Inv/Check #	Description	Invoice Amt	Check Amt
06/06/2023	INVOICE	194294/5	KEY MASTER, KEY BANDS	11.91	
06/06/2023	INVOICE	194308/5	AJAX CLEANER	12.90	
06/06/2023	INVOICE	194315/5	CONCRETE MIX	4.89	
Total:				1,137.17	
Net of 44 Invoices / 0 Checks				1,137.17	
00180	ADVANCE AUTO PARTS				
06/06/2023	INVOICE	5606312963639	STARTER	273.11	
06/06/2023	INVOICE	5606312863615	PAINTED ROTOR	(139.08)	
06/06/2023	INVOICE	5606312963636	FUEL FILTER	20.29	
06/06/2023	INVOICE	5606312563539	BRAKE PADS, PAINTED ROTOR	185.87	
06/06/2023	INVOICE	5606313163710	BATTERY	54.21	
06/06/2023	INVOICE	5606313063675	WHEEL STUD	17.28	
06/06/2023	INVOICE	5606313263754	5 WIRE MF CONN	10.70	
06/06/2023	INVOICE	5606313163720	BRAKE PADS	(46.79)	
06/06/2023	INVOICE	5606313263753	HYDRAULIC	8.67	
06/06/2023	INVOICE	5606313563877	MULTI PURPOSE CONNECTOR	31.15	
06/06/2023	INVOICE	5606310963054	OIL FILTER	4.18	
06/06/2023	INVOICE	5606310362832	MULTIFUNCTION SWITCH	102.48	
06/06/2023	INVOICE	5606309562568	OIL FILTER	6.29	
Total:				528.36	
Net of 13 Invoices / 0 Checks				528.36	
00102	AG SPRAY EQUIPMENT				
06/06/2023	INVOICE	679855	HOSE BARB, TEEJET, AIR INDUCTION	97.89	
06/06/2023	INVOICE	682712	BALL VALVE, HOSE BARB, POLY PIPE NIPPLE, SPR	71.55	
06/06/2023	INVOICE	688973	STRAINER HEAD, REDUCER BEARRING & NIPPLE, TI	28.20	
Total:				197.64	
Net of 3 Invoices / 0 Checks				197.64	
11016	ALBERS AUSTIN				
06/06/2023	INVOICE	5.30.2023	UMP: MEN'S LEAGUE 5/23	60.00	
Total:				60.00	
Net of 1 Invoices / 0 Checks				60.00	
00559	ALTEC INDUSTRIES INC				
06/06/2023	INVOICE	51218286	PM INSPECTION, DIELECTRIC TEST - VIN #6619	1,206.00	
06/06/2023	INVOICE	51220730	PM INSPECTION & DIELECTRIC TESTS VIN #6145	1,490.23	
Total:				2,696.23	
Net of 2 Invoices / 0 Checks				2,696.23	
10561	ARNOLD MOTOR SUPPLY				
06/06/2023	INVOICE	78NV069187	HI-POWER II V-BELT	14.68	
06/06/2023	INVOICE	78NV068778	O-RING, FLANGE O-RING	1.89	
06/06/2023	INVOICE	78NV068664	FLANGE O-RING, RAVEN NITRILE XL, RGS BX BLUJ	142.33	
06/06/2023	INVOICE	78NV067505	VULCO STRAIGHT COOLANT HOSE	115.56	
06/06/2023	INVOICE	78NV067422	VULCO STRAIGHT COOLANT HOSE	38.52	
06/06/2023	INVOICE	78NV068249	TRLR-CONN, CONNECTOR	26.98	
06/06/2023	INVOICE	78NV069037	100/FT TRL-CONN	399.00	
06/06/2023	INVOICE	78NV068808	O-RING, WIRE BRAID HOSE	72.11	
06/06/2023	INVOICE	78NV070336	OIL FILTER, PM 5W30 SYN BLEND	54.02	

Vendor Code Post Date	Vendor Name Activity	Inv/Check #	Description	Invoice Amt	Check Amt
06/06/2023	INVOICE	78NV070642	PM OW20 SYN 3/5 QT	56.00	
06/06/2023	INVOICE	78NV070653	BLUE WASHER FLUID	8.38	
06/06/2023	INVOICE	78NV070335	OIL FILTER, PM 5W20 SYN BLEND, BATTERY CHAR	101.09	
			Total:	1,030.56	
			Net of 12 Invoices / 0 Checks	1,030.56	
11013	AUTOGRAPHIX INC				
06/06/2023	INVOICE	196886	REFLECTIVE GRAPHICS	1,675.00	
			Total:	1,675.00	
			Net of 1 Invoices / 0 Checks	1,675.00	
02344	BAIRD HOLM LLP				
06/06/2023	INVOICE	295103	DISTRICT TIF	3,022.00	
			Total:	3,022.00	
			Net of 1 Invoices / 0 Checks	3,022.00	
10992	BARNES ELEANOR				
06/06/2023	INVOICE	5.23.2023	CEMETARY LOT - SECTION O LOT 182 SPACE 7	200.00	
			Total:	200.00	
			Net of 1 Invoices / 0 Checks	200.00	
10822	BARRELHOUSE				
06/06/2023	INVOICE	5.09.2023	2 HOUR SHOW - SUMMER CONCERT SERIES	800.00	
			Total:	800.00	
			Net of 1 Invoices / 0 Checks	800.00	
11019	BAUER MICHELLE				
06/06/2023	INVOICE	REFUND	REFUND MEMBERSHIP-S/B HOUSEHOLD MEMBERSHIP	200.00	
			Total:	200.00	
			Net of 1 Invoices / 0 Checks	200.00	
03119	B-D CONSTRUCTION INC				
06/06/2023	INVOICE	13	COLUMBUS FIRE STATION #2	128,685.39	
			Total:	128,685.39	
			Net of 1 Invoices / 0 Checks	128,685.39	
MISC	BEHLE NICHOLAS				
06/06/2023	INVOICE	05/17/2023	UB refund for account: 300-58440-04	45.48	
			Total:	45.48	
			Net of 1 Invoices / 0 Checks	45.48	
02782	BENCK BRIAN D				
06/06/2023	INVOICE	5.24.2023ENG	REIMBURSE PURCHASE AT MENARDS	245.31	
			Total:	245.31	
			Net of 1 Invoices / 0 Checks	245.31	
10996	BEST BUY BUSINESS ADVANTAGE ACCOUNT				

Vendor Code Post Date	Vendor Name Activity	Inv/Check #	Description	Invoice Amt	Check Amt
06/06/2023	INVOICE	6961987	4 - SAMSUNG 43" SMART TVS	969.96	
			Total:	969.96	
			Net of 1 Invoices / 0 Checks	969.96	
10435 06/06/2023	BEST VERSION MEDIA, LLC INVOICE	316377-202307	AD MANAGEMENT FEE	152.00	
			Total:	152.00	
			Net of 1 Invoices / 0 Checks	152.00	
01834 06/06/2023	BOARDERS INN & SUITES INVOICE	228	LODGING FIRE SCHOOL - FRENCH, NELSON, LEFFEL	1,499.40	
			Total:	1,499.40	
			Net of 1 Invoices / 0 Checks	1,499.40	
00337	BOMGAARS				
06/06/2023	INVOICE	35137182	PULLEY, PAIRED DISCONNECT, BOLTS	13.34	
06/06/2023	INVOICE	35137802	ELBOW, HOSE BARB	6.48	
06/06/2023	INVOICE	35138305	TORCH KIT	64.99	
06/06/2023	INVOICE	35142021	PIPE HANGER, HANGER STRAP, BRAZING ROD	27.37	
06/06/2023	INVOICE	35142349	CHOP SAW WHEEL	23.96	
06/06/2023	INVOICE	35145457	ANTIFREEZ	29.98	
06/06/2023	INVOICE	35146032	HAMMER, PINS	31.06	
06/06/2023	INVOICE	35146850	UNLINED GLOVES, GRAB & GO SPRAYER	76.93	
06/06/2023	INVOICE	35147250	STRAP	11.99	
06/06/2023	INVOICE	35147448	2 - JACKETS - LINED HI-V	119.98	
06/06/2023	INVOICE	35150493	COUPLERS	14.98	
06/06/2023	INVOICE	35150799	SIDEWALK SCRAPER	9.88	
06/06/2023	INVOICE	35151392	EXTENSION CORD, SURFACE RECEPTACLE	44.98	
06/06/2023	INVOICE	35143215	HITCHING RING, SNAP SPRINGS	30.09	
06/06/2023	INVOICE	35152227	BOLTS, FASTENERS	1.16	
06/06/2023	INVOICE	35150327	SOCKET 12PT, JUMBO WRENCH	62.98	
06/06/2023	INVOICE	35142493	LOCKING CONNECTOR	29.99	
			Total:	600.14	
			Net of 17 Invoices / 0 Checks	600.14	
11015 06/06/2023	BORCHERS DEVON INVOICE	5.30.2023	UMP: MIXED LEAGUE 5/17, 5/24	180.00	
			Total:	180.00	
			Net of 1 Invoices / 0 Checks	180.00	
00240	BOUND TREE MEDICAL LLC				
06/06/2023	INVOICE	84963945	LANCETS	122.50	
06/06/2023	INVOICE	84959882	GLUTOSE 15GM, ELECTRODES MULTIPLE FUNCTION	705.04	
			Total:	827.54	
			Net of 2 Invoices / 0 Checks	827.54	
00111 06/06/2023	BRUNKEN JED INVOICE	06.01.2023	ANNUAL LEASE FOR QR SIGN PLACEMENT	1.00	
			Total:	1.00	

Vendor Code Post Date	Vendor Name Activity	Inv/Check #	Description	Invoice Amt	Check Amt
			Net of 1 Invoices / 0 Checks	1.00	
10959 06/06/2023	BSN SPORTS LLC INVOICE	921647067	HOMERUN FENCE	4,431.01	
			Total:	4,431.01	
			Net of 1 Invoices / 0 Checks	4,431.01	
11011 06/06/2023	CAMBRIA HOTEL OMAHA DOWNTOWN INVOICE	67347383	CLETE BORCHERS	429.65	
06/06/2023	INVOICE	67347380	DAVE SLIVA	429.65	
			Total:	859.30	
			Net of 2 Invoices / 0 Checks	859.30	
02979 06/06/2023	CAPITAL BUSINESS SYSTEMS INVOICE	1278062	COPIER CONTRACT	29.33	
			Total:	29.33	
			Net of 1 Invoices / 0 Checks	29.33	
10626 06/06/2023	CAPITAL ONE - WALMART INVOICE	751586	FACE TISSUE	9.98	
06/06/2023	INVOICE	39570	FOAM CUPS, BATTERIES, TAPE MEASURE, TRASH B	79.32	
06/06/2023	INVOICE	583137	ONN 16GB, 32G USB 3PK	49.28	
06/06/2023	INVOICE	677431	CAT FOOD, TRASH BAGS	117.32	
06/06/2023	INVOICE	605615	HOTDOG BUNS, POWERADE, HOTDOGS, WATER	182.68	
06/06/2023	INVOICE	226525	SUPPLIES FOR AQUATICS CORAL CLASS	50.56	
06/06/2023	INVOICE	711806	BUNS, POP, POWERADE, WATER	305.92	
			Total:	795.06	
			Net of 7 Invoices / 0 Checks	795.06	
00091 06/06/2023	CAROLINA SOFTWARE INVOICE	87063	WASTE WORKS LASER TICKETS	790.86	
			Total:	790.86	
			Net of 1 Invoices / 0 Checks	790.86	
10604 06/06/2023	CASEY'S MAIL SERVICE LLC INVOICE	2815	DAILY POSTAGE, WATER STATEMENTS	4,262.28	
06/06/2023	INVOICE	2831	LIBRARY/MEDIA MAIL	522.95	
			Total:	4,785.23	
			Net of 2 Invoices / 0 Checks	4,785.23	
00060 06/06/2023	CDW GOVERNMENT INVOICE	JW40095	MIC ROSOFT WINDOWS SERVER	871.94	
			Total:	871.94	
			Net of 1 Invoices / 0 Checks	871.94	
01209 06/06/2023	CENTER POINT LARGE PRINT INVOICE	2021058	MATERIALS	21.75	
			Total:	21.75	

Vendor Code Post Date	Vendor Name Activity	Inv/Check #	Description	Invoice Amt	Check Amt
Net of 1 Invoices / 0 Checks				21.75	
00567	CITY OF COLUMBUS				
06/06/2023	INVOICE	300-47516-00	JUNE WATER & SEWER	42.92	
06/06/2023	INVOICE	300-54059-00	JUNE WATER & SEWER	92.50	
06/06/2023	INVOICE	200-21960-05	JUNE WATER & SEWER	113.27	
06/06/2023	INVOICE	200-39575-00	JUNE WATER & SEWER	25.19	
06/06/2023	INVOICE	300-44985-02	JUNE WATER & SEWER	25.19	
06/06/2023	INVOICE	300-47514-00	JUNE WATER & SEWER	1,450.74	
06/06/2023	INVOICE	300-47518-00	JUNE WATER & SEWER	50.55	
06/06/2023	INVOICE	300-49615-00	JUNE WATER & SEWER	15.78	
06/06/2023	INVOICE	300-62105-00	JUNE WATER & SEWER	120.29	
06/06/2023	INVOICE	300-62155-00	JUNE WATER & SEWER	190.03	
06/06/2023	INVOICE	200-21980-02	JUNE WATER & SEWER	89.97	
06/06/2023	INVOICE	100-13650-01	JUNE WATER & SEWER	167.38	
06/06/2023	INVOICE	200-21805-00	JUNE WATER & SEWER	95.14	
06/06/2023	INVOICE	200-28755-00	JUNE WATER & SEWER	43.16	
06/06/2023	INVOICE	200-37998-00	JUNE WATER & SEWER	279.97	
06/06/2023	INVOICE	200-39771-00	JUNE WATER & SEWER	154.35	
06/06/2023	INVOICE	200-41055-00	JUNE WATER & SEWER	26.46	
06/06/2023	INVOICE	200-44032-00	JUNE WATER & SEWER	89.97	
06/06/2023	INVOICE	300-44986-00	JUNE WATER & SEWER	102.65	
06/06/2023	INVOICE	300-44995-00	JUNE WATER & SEWER	95.68	
06/06/2023	INVOICE	300-45761-00	JUNE WATER & SEWER	25.72	
06/06/2023	INVOICE	300-45762-00	JUNE WATER & SEWER	27.18	
06/06/2023	INVOICE	300-47515-00	JUNE WATER & SEWER	548.29	
06/06/2023	INVOICE	300-47517-00	JUNE WATER & SEWER	597.17	
06/06/2023	INVOICE	300-49665-00	JUNE WATER & SEWER	71.96	
06/06/2023	INVOICE	300-50035-00	JUNE WATER & SEWER	57.58	
06/06/2023	INVOICE	300-57935-00	JUNE WATER & SEWER	3,421.91	
06/06/2023	INVOICE	300-57936-00	JUNE WATER & SEWER	234.73	
06/06/2023	INVOICE	300-57937-00	JUNE WATER & SEWER	170.94	
06/06/2023	INVOICE	300-61005-00	JUNE WATER & SEWER	360.83	
06/06/2023	INVOICE	400-65101-00	JUNE WATER & SEWER	92.50	
06/06/2023	INVOICE	400-69475-00	JUNE WATER & SEWER	483.36	
06/06/2023	INVOICE	400-81020-00	JUNE WATER & SEWER	318.57	
06/06/2023	INVOICE	300-57934-00	JUNE WATER & SEWER	257.62	
06/06/2023	INVOICE	200-39615-01	JUNE WATER & SEWER	108.36	
06/06/2023	INVOICE	300-57938-00	JUNE WATER & SEWER	89.97	
06/06/2023	INVOICE	400-70005-01	JUNE WATER & SEWER	309.42	
Total:				10,447.30	
Net of 37 Invoices / 0 Checks				10,447.30	
00607	CIVIL AIR PATROL MAGAZINE				
06/06/2023	INVOICE	DMH1515213	ADVERTISING	105.00	
Total:				105.00	
Net of 1 Invoices / 0 Checks				105.00	
10379	CLEANWASH LAUNDRY SYSTEMS INC.				
06/06/2023	INVOICE	13765	BALANCE DUE	56.00	
Total:				56.00	
Net of 1 Invoices / 0 Checks				56.00	
10827	CLINE RANDY				

Vendor Code Post Date	Vendor Name Activity	Inv/Check #	Description	Invoice Amt	Check Amt
06/06/2023	INVOICE	5.30.2023	UMP: MEN'S LEAGUE 5/16, 5/23; MIXED LEAGUE !	350.00	
			Total:	350.00	
			Net of 1 Invoices / 0 Checks	350.00	
10826 06/06/2023	CLINE TYLER INVOICE	5.30.2023	UMP: MEN'S LEAGUE 5/16, 5/23; MIXED LEAGUE !	300.00	
			Total:	300.00	
			Net of 1 Invoices / 0 Checks	300.00	
00262 06/06/2023	CLUB PROPHET SYSTEMS INVOICE	INV1393365	MONTHLY ADDITIONAL USER	60.00	
			Total:	60.00	
			Net of 1 Invoices / 0 Checks	60.00	
03141 06/06/2023	COLUMBUS COMMUNITY HOSPITAL INVOICE	10002274	MEDICAL SUPPLIES	1,411.45	
			Total:	1,411.45	
			Net of 1 Invoices / 0 Checks	1,411.45	
00036 06/06/2023	COLUMBUS CUSTOM EMBROIDERY INVOICE	E42571	POLOS - DOUG & MICHELLE MOORE	119.00	
			Total:	119.00	
			Net of 1 Invoices / 0 Checks	119.00	
00127 06/06/2023	COLUMBUS SCREEN PRINTING INVOICE	035197	SHIRTS	421.00	
06/06/2023	INVOICE	035196	SHIRTS	147.00	
06/06/2023	INVOICE	035185	T-SHIRTS, HOODIES	2,826.00	
			Total:	3,394.00	
			Net of 3 Invoices / 0 Checks	3,394.00	
01250 06/06/2023	COMMONWEALTH ELECTRIC COMPANY INVOICE	10294	3 PHASE FLAGS NOT WORKING - PAWNEE PLUNGE	189.00	
			Total:	189.00	
			Net of 1 Invoices / 0 Checks	189.00	
03149 06/06/2023	CULLIGAN OF COLUMBUS INVOICE	267706	DI REGENERATION	379.07	
06/06/2023	INVOICE	267568	SALT PELLET DELIVERED 50#	52.00	
			Total:	431.07	
			Net of 2 Invoices / 0 Checks	431.07	
03151 06/06/2023	CURTIS DANIEL INVOICE	5192023	FEE FOR KEN STEINER TRAINING VIDEO	69.00	
			Total:	69.00	
			Net of 1 Invoices / 0 Checks	69.00	

Vendor Code Post Date	Vendor Name Activity	Inv/Check #	Description	Invoice Amt	Check Amt
01539 06/06/2023	D & K PRODUCTS INVOICE	66413IN	IGNITION 18-3-6, IGNITION IRON PLUS	1,007.50	
			Total:	1,007.50	
			Net of 1 Invoices / 0 Checks	1,007.50	
00270 06/06/2023	DANKO EMERGENCY EQUIPMENT INVOICE	129677	HORIZONTAL FOR 6.75 TO 7.25, RESTRAINT STRAI	355.50	
			Total:	355.50	
			Net of 1 Invoices / 0 Checks	355.50	
03279 06/06/2023	DAS STATE ACCOUNTING INVOICE	1372421	MONTHLY NETWORK CHARGES	256.00	
06/06/2023	INVOICE	1372471	MONTHLY NETWORK CHARGES	1,215.99	
			Total:	1,471.99	
			Net of 2 Invoices / 0 Checks	1,471.99	
11014 06/06/2023	DOMINGUEZ MARK INVOICE	5.30.2023	UMP: MEN'S LEAGUE 5/16; MIXED LEAGUE 5/17, !	240.00	
			Total:	240.00	
			Net of 1 Invoices / 0 Checks	240.00	
03158 06/06/2023	EAKES OFFICE SOLUTIONS INVOICE	8729808-0	TONER	171.99	
06/06/2023	INVOICE	8729067-0	COMP BOOKS, JNR PAD	62.47	
06/06/2023	INVOICE	8726473-0	PAPER	50.49	
06/06/2023	INVOICE	8726472-0	PENS, REFILLS	47.10	
06/06/2023	INVOICE	8725400-1	LAMINATE	44.64	
06/06/2023	INVOICE	8721139-1	PAGE MARKER FLAGS	7.49	
06/06/2023	INVOICE	8728940-0	INK CARTRIDGES	285.12	
06/06/2023	INVOICE	8728906-0	LAMINATE, TAPE, DRUM UNIT, LEGAL PAD, TONER	391.60	
06/06/2023	INVOICE	8728626-0	PENS	17.99	
06/06/2023	INVOICE	8715845-1	CORRECTION TAPE	19.96	
06/06/2023	INVOICE	8721140-0	PAPER, PENS, SHARPIE MARKERS	31.18	
06/06/2023	INVOICE	8721139-0	WIPES	25.99	
06/06/2023	INVOICE	INV456848	COPIER CONTRACT	109.01	
06/06/2023	INVOICE	INV456644	COPIER CONTRACT	241.61	
06/06/2023	INVOICE	8718546-0	BADGES	19.94	
06/06/2023	INVOICE	8724687-0	SHREDDER LUBRICANT-ARPA FUNDS	9.99	
06/06/2023	INVOICE	8724234-0	PERFERED PAPER	219.80	
06/06/2023	INVOICE	8725400-0	CENTER PULL TOWELS	123.81	
06/06/2023	INVOICE	8724926-0	HANGING LEGAL FOLDERS	56.67	
06/06/2023	INVOICE	8724687-1	SHREDDER -ARPA FUNDS	289.99	
06/06/2023	INVOICE	8697937-0	INK CARTRIDGES	327.01	
06/06/2023	INVOICE	8709580-0	INKPAD	10.25	
06/06/2023	INVOICE	INV448966	COPIER CONTRACT	405.06	
06/06/2023	INVOICE	INV457608	COPIER CONTRACT	201.72	
06/06/2023	INVOICE	8721140-1	PENS	17.99	
			Total:	3,188.87	
			Net of 25 Invoices / 0 Checks	3,188.87	
01398	EARL MAY SEED & NURSERY L.C.				

Vendor Code Post Date	Vendor Name Activity	Inv/Check #	Description	Invoice Amt	Check Amt
06/06/2023	INVOICE	00005366	PLANTS	202.81	
			Total:	202.81	
			Net of 1 Invoices / 0 Checks	202.81	
00191	ELECTRIC PUMP INC				
06/06/2023	INVOICE	0898384-IN	SERVICE CALL - NEW POWER SUPPLIES & BATTERY	1,751.00	
06/06/2023	INVOICE	0901189-IN	MULTISMART SCREEN REPAIR	1,141.81	
			Total:	2,892.81	
			Net of 2 Invoices / 0 Checks	2,892.81	
03161	ELECTRICAL ENGINEERING &				
06/06/2023	INVOICE	8246566-00	UR-I IDC CONN/100 PK	21.35	
06/06/2023	INVOICE	8251249-00	BAYE3-PS240-FCCT-U 240/200/180W120-277V DI	185.00	
			Total:	206.35	
			Net of 2 Invoices / 0 Checks	206.35	
01597	ELECTRONIC ENGINEERING				
06/06/2023	INVOICE	855002032-1	ANTENNA ROD, COUPLING NUT	7.68	
06/06/2023	INVOICE	853004908	2 WAY RADIO INSTALL - MEDIC 12	570.42	
			Total:	578.10	
			Net of 2 Invoices / 0 Checks	578.10	
03165	FASTENAL COMPANY				
06/06/2023	INVOICE	NECOL249574	100 - 12-24X7/8 HWH TEKS4	33.98	
			Total:	33.98	
			Net of 1 Invoices / 0 Checks	33.98	
00169	FRONTIER				
06/06/2023	INVOICE	40256399170413232	TELEPHONE NEW BUILDING - 5/13/23 TO 6/12/23	271.74	
			Total:	271.74	
			Net of 1 Invoices / 0 Checks	271.74	
00459	GALE				
06/06/2023	INVOICE	81033581	MATERIALS	91.17	
06/06/2023	INVOICE	81076862	MATERIALS	48.80	
06/06/2023	INVOICE	81062887	MATERIALS	78.72	
			Total:	218.69	
			Net of 3 Invoices / 0 Checks	218.69	
03172	GALLS LLC				
06/06/2023	INVOICE	024551883	BATON, KEY HOLDER, BELT, HANDCUFF CASE, MAG	645.17	
			Total:	645.17	
			Net of 1 Invoices / 0 Checks	645.17	
03174	GEHRING CONSTRUCTION &				
06/06/2023	INVOICE	5	SID #189 - 48TH AVE FROM 23RD ST TO S OF BR	813,356.46	
06/06/2023	INVOICE	9	SID #184 - 23RD STREET FROM EAST OF 48TH AV	92,234.00	
06/06/2023	INVOICE	69578	3413 34TH STREET	706.13	

Vendor Code Post Date	Vendor Name Activity	Inv/Check #	Description	Invoice Amt	Check Amt
06/06/2023	INVOICE	69180	FIBER EXPANSION	45.00	
06/06/2023	INVOICE	69171	4110 SUNSET DR	842.63	
06/06/2023	INVOICE	69212	4110 SUNSET DR	697.50	
06/06/2023	INVOICE	69309	NON SHRINK GROUT	14.93	
06/06/2023	INVOICE	69381	2270 CIRCLE DRIVE	663.00	
Total:				908,559.65	
Net of 8 Invoices / 0 Checks				908,559.65	
03178	GERHOLD CONCRETE COMPANY				
06/06/2023	INVOICE	385140	4114 SUNSET DRIVE	798.33	
Total:				798.33	
Net of 1 Invoices / 0 Checks				798.33	
00053	GILMORE & ASSOCIATES INC				
06/06/2023	INVOICE	38161	SEWER STUDY & LIFT STATION #14 RENOVATIONS :	7,000.00	
Total:				7,000.00	
Net of 1 Invoices / 0 Checks				7,000.00	
00056	GODFATHER'S PIZZA				
06/06/2023	INVOICE	6105	PIZZA	31.73	
06/06/2023	INVOICE	6122	PIZZA	84.45	
06/06/2023	INVOICE	6106	PIZZA	68.00	
06/06/2023	INVOICE	6103	PIZZA	124.00	
06/06/2023	INVOICE	6126	PIZZA	29.99	
Total:				338.17	
Net of 5 Invoices / 0 Checks				338.17	
02594	GREAT PLAINS BUILDING SUPPLY				
06/06/2023	INVOICE	2305-513584	ATHLETIC FIELD MARKER	608.16	
Total:				608.16	
Net of 1 Invoices / 0 Checks				608.16	
02075	GREAT PLAINS COMMUNICATIONS				
06/06/2023	INVOICE	139461 4025648127	PHONE/INTERNET CHARGES 05/16 - 06/15	1,412.91	
Total:				1,412.91	
Net of 1 Invoices / 0 Checks				1,412.91	
01070	GREY HOUSE PUBLISHING INC				
06/06/2023	INVOICE	974045	WEISS RATINGS CONSUMER BOX SET	462.05	
Total:				462.05	
Net of 1 Invoices / 0 Checks				462.05	
02904	GUNSLINGERS LLC				
06/06/2023	INVOICE	19861	SPRINGFIELD GARISON 1911 - WANGLER QM	800.00	
06/06/2023	INVOICE	19978	NC AARS1P SNG POINT SLING BLK - URKOSKI QM	15.00	
06/06/2023	INVOICE	19980	STREAMLIGHT TLR-1HL - LEVANDER QM	175.00	
Total:				990.00	
Net of 3 Invoices / 0 Checks				990.00	

Vendor Code Post Date	Vendor Name Activity	Inv/Check #	Description	Invoice Amt	Check Amt
11017 06/06/2023	GUTIERREZ JUAN INVOICE	5.30.2023	UMP: MEN'S LEAGUE 5/23; MIXED LEAGUE 5/24	150.00	
			Total:	150.00	
			Net of 1 Invoices / 0 Checks	150.00	
03183 06/06/2023	HADLEY-BRAITHWAIT COMPANY INVOICE	228770	MULTIFOLD TOWELS	202.85	
06/06/2023	INVOICE	228744	2 CASES COFFEE FILTERS	63.00	
06/06/2023	INVOICE	228713	MULTIFOLD TOWELS, TOILET PAPER	260.80	
06/06/2023	INVOICE	228683	CASE MULTIFOLD TOWELS	45.95	
06/06/2023	INVOICE	228664	TOILET PAPER, CENTER PULL TOWELS	117.90	
			Total:	690.50	
			Net of 5 Invoices / 0 Checks	690.50	
00272 06/06/2023	HAWKINS INC INVOICE	6474280	CHEMICALS	4,100.66	
06/06/2023	INVOICE	6482213	CHEMICALS	6,227.75	
			Total:	10,328.41	
			Net of 2 Invoices / 0 Checks	10,328.41	
03185 06/06/2023	HDR ENGINEERING INC INVOICE	1200521635	LOST CREEK PARKWAY SEWER PROJECT	10,442.02	
06/06/2023	INVOICE	1200521198	DESIGN/CONSTRUCTION PHASE SERVICES LOST CREI	2,470.36	
			Total:	12,912.38	
			Net of 2 Invoices / 0 Checks	12,912.38	
00150 06/06/2023	HOMETOWN LEASING INVOICE	9	COPIER LEASE PAYMENT	175.00	
			Total:	175.00	
			Net of 1 Invoices / 0 Checks	175.00	
00088 06/06/2023	INDUSTRIAL CONTROL SYSTEMS INC INVOICE	2684	EXPRESS DUAL 3000 BLADE SHARPENER - REPLACE	450.00	
06/06/2023	INVOICE	2692	TROUBLE SHOOT MAIN MOTOR, INSTALL START CAP	932.41	
			Total:	1,382.41	
			Net of 2 Invoices / 0 Checks	1,382.41	
03194 06/06/2023	INGRAM LIBRARY SERVICES, INC INVOICE	75852775	MATERIALS	42.80	
06/06/2023	INVOICE	75859095	MATERIALS	21.68	
06/06/2023	INVOICE	75899461	MATERIALS	215.77	
06/06/2023	INVOICE	75789269	MATERIALS	118.90	
06/06/2023	INVOICE	75985719	MATERIALS	54.23	
06/06/2023	INVOICE	76006057	MATERIALS	40.22	
			Total:	493.60	
			Net of 6 Invoices / 0 Checks	493.60	
03196 06/06/2023	INTERNATL INSTITUTE OF INVOICE	27924	ANNUAL MEMBERSHIP - JANELLE KLINE, KELLI KE'	350.00	

Vendor Code Post Date	Vendor Name Activity	Inv/Check #	Description	Invoice Amt	Check Amt
Total:				350.00	
Net of 1 Invoices / 0 Checks				350.00	
02554	INTERSTATE BATTERY SYSTEM				
06/06/2023	INVOICE	210088288	2 - BATTERIES	210.90	
06/06/2023	INVOICE	200054828	2 - BATTERIES	505.90	
Total:				716.80	
Net of 2 Invoices / 0 Checks				716.80	
03199	JACKSON SERVICES INC				
06/06/2023	INVOICE	5049299	UNIFORMS	25.79	
06/06/2023	INVOICE	5050324	UNIFORMS	86.56	
06/06/2023	INVOICE	5049323	TEA TOWELS, BAR MOPS	31.63	
06/06/2023	INVOICE	5051267	UNIFORMS	100.83	
06/06/2023	INVOICE	5051259	UNIFORMS	122.18	
06/06/2023	INVOICE	5051268	MAT	2.92	
06/06/2023	INVOICE	5049308	MAT	26.82	
06/06/2023	INVOICE	5053049	MATS, MOPS, POLISH TOWEL, WINDSHIELD WIPE, :	133.66	
06/06/2023	INVOICE	5052206	UNIFORMS	123.24	
06/06/2023	INVOICE	5044730	UNIFORMS	25.86	
06/06/2023	INVOICE	5048343	MATS, ROLLER TOWELS, UNIFORMS	150.12	
06/06/2023	INVOICE	5046644	MATS, BAR TOWELS, SHOP TOWELS	33.47	
06/06/2023	INVOICE	5046643	UNIFORMS	100.90	
06/06/2023	INVOICE	5046635	UNIFORMS	122.25	
06/06/2023	INVOICE	5045761	UNIFORMS	90.01	
06/06/2023	INVOICE	5044746	MATS	63.50	
06/06/2023	INVOICE	5044621	RAGS-BAR MOP	20.00	
06/06/2023	INVOICE	5046633	MATS, SHOP TOWELS, UNIFORMS	285.67	
06/06/2023	INVOICE	5051257	UNIFORMS	243.04	
06/06/2023	INVOICE	5055756	UNIFORMS	249.96	
06/06/2023	INVOICE	5053860	UNIFORMS	25.71	
06/06/2023	INVOICE	5053861	UNIFORMS	78.71	
06/06/2023	INVOICE	5053876	MATS	63.35	
06/06/2023	INVOICE	5023322	UNIFORMS	27.18	
06/06/2023	INVOICE	5037623	UNIFORMS	27.12	
06/06/2023	INVOICE	5055769	MAT, BAR TOWELS, SHOP TOWELS	23.79	
06/06/2023	INVOICE	5055768	UNIFORMS	100.75	
06/06/2023	INVOICE	5055767	MATS, ROLLER TOWELS, UNIFORMS	153.82	
06/06/2023	INVOICE	5055759	2 SOAP FOAM BAGS	36.00	
06/06/2023	INVOICE	5055758	UNIFORMS	122.10	
06/06/2023	INVOICE	5046645	UNIFORMS	40.00	
06/06/2023	INVOICE	5055770	UNIFORMS	40.00	
06/06/2023	INVOICE	5060107	CREDIT BACK MINIMUM STOP CHARGES	(26.59)	
Total:				2,750.35	
Net of 33 Invoices / 0 Checks				2,750.35	
00532	JEO CONSULTING GROUP INC				
06/06/2023	INVOICE	141183	FLOOD MITIGATION & RESILIENCY PLAN	21,388.60	
Total:				21,388.60	
Net of 1 Invoices / 0 Checks				21,388.60	
01761	JOHNSON SERVICE COMPANY				
06/06/2023	INVOICE	17075	INSTALL 15" POINT REPAIR LINER	14,000.00	

Vendor Code Post Date	Vendor Name Activity	Inv/Check #	Description	Invoice Amt	Check Amt
			Total:	14,000.00	
			Net of 1 Invoices / 0 Checks	14,000.00	
10528 06/06/2023	JOHNSON, MADDY INVOICE	420072	REIMBURSE CRACKED WINDSHEILD	64.28	
			Total:	64.28	
			Net of 1 Invoices / 0 Checks	64.28	
03005 06/06/2023	JONES AUTOMOTIVE INVOICE	2-54953	LIGH & SIREN PACKAGE- 2022 CHEVY VIN #2441	25,994.41	
			Total:	25,994.41	
			Net of 1 Invoices / 0 Checks	25,994.41	
03202 06/06/2023	KELLY SUPPLY COMPANY INVOICE	S12284982-2	FLANGE SPIGOT	75.88	
06/06/2023	INVOICE	S12285116-0	1" ISO-A SEAL KIT	10.05	
06/06/2023	INVOICE	S12285166-0	PVC-40 COMP COUP	65.70	
06/06/2023	INVOICE	S12285225-0	ALUMINUM COUPLING	200.95	
06/06/2023	INVOICE	S12284618-0	BRASS ADAPTERS	95.04	
06/06/2023	INVOICE	S12284508-1	ADPT FL, FEMALE ADAPTER	84.54	
06/06/2023	INVOICE	S12284717-1	DIXON BUNA-N GASKET	17.61	
06/06/2023	INVOICE	S12285022-0	GATES STEM, HYDRAULIC HOSE	58.08	
06/06/2023	INVOICE	S12284982-1	FLANGE SPIGOT, SLIP FLANGE	112.11	
06/06/2023	INVOICE	S12284993-0	PVC ELL SOC, SLIP FLANGE, VACUUM BREAKER	154.30	
06/06/2023	INVOICE	S12284982-0	PVC TEE, ELL SOC, PLASTIC PIPE, PLUMBING CEI	409.88	
06/06/2023	INVOICE	S12284782-0	DISCHARGE HOSE, ALUMINUM COUPLING, GASKET	1,759.21	
			Total:	3,043.35	
			Net of 12 Invoices / 0 Checks	3,043.35	
10247 06/06/2023	LABORDE, ADAM INVOICE	GIS-0015	GIS SUPPORT SERVICES MARCH/APRIL 2023	1,300.00	
			Total:	1,300.00	
			Net of 1 Invoices / 0 Checks	1,300.00	
00012 06/06/2023	LAKEVIEW SMALL ENGINE INC INVOICE	050492	DIPSTICK	40.28	
			Total:	40.28	
			Net of 1 Invoices / 0 Checks	40.28	
02596 06/06/2023	LAWSON PRODUCTS INVOICE	9310629632	GATES 2 BRAID HOSE	523.50	
			Total:	523.50	
			Net of 1 Invoices / 0 Checks	523.50	
03210 06/06/2023	LEAGUE OF NEBR MUNICIPALITIES INVOICE	2023	2023 MUNICIPAL ACCOUNTING & FINANCE CONFEREI	535.00	
			Total:	535.00	
			Net of 1 Invoices / 0 Checks	535.00	

Vendor Code Post Date	Vendor Name Activity	Inv/Check #	Description	Invoice Amt	Check Amt
00223 06/06/2023	LEVANDER JAYMEE INVOICE	0000734485	TUITION REIMBURSEMENT	500.00	
			Total:	500.00	
			Net of 1 Invoices / 0 Checks	500.00	
11009 06/06/2023	LOPEZ ANDY G INVOICE	582023	SATURDAY CONCERT SERIES: ANDY WILLIAM & THE	3,000.00	
			Total:	3,000.00	
			Net of 1 Invoices / 0 Checks	3,000.00	
00518 06/06/2023	LOSEKE LAKE STOP LLC INVOICE	2633	36 - SOD ROLLS	132.84	
			Total:	132.84	
			Net of 1 Invoices / 0 Checks	132.84	
02806 06/06/2023	MACQUEEN EQUIPMENT INVOICE	W03385	REPAIR SWEEPER	7,082.95	
			Total:	7,082.95	
			Net of 1 Invoices / 0 Checks	7,082.95	
10213 06/06/2023	MAHASKA INVOICE	MARO018166	COLD BREW	230.00	
			Total:	230.00	
			Net of 1 Invoices / 0 Checks	230.00	
10620 06/06/2023	MALLOY ELECTRIC INVOICE	6471211	SERVICE ON MOTOR	758.46	
06/06/2023	INVOICE	6471210	SERVICE ON MOTOR	1,041.36	
06/06/2023	INVOICE	6471209	SERVICE ON MOTOR	1,041.36	
			Total:	2,841.18	
			Net of 3 Invoices / 0 Checks	2,841.18	
03212 06/06/2023	MATHESON-LINWELD INVOICE	0027735567	CARBON DIOXIDE 10LB AL	60.00	
06/06/2023	INVOICE	0027767226	MEDICAL OXYGEN	96.19	
			Total:	156.19	
			Net of 2 Invoices / 0 Checks	156.19	
01362 06/06/2023	MCCROMETER INC INVOICE	586567	PCB ASSY	595.24	
			Total:	595.24	
			Net of 1 Invoices / 0 Checks	595.24	
03220 06/06/2023	MENARDS INVOICE	86333	RETURN - FURANCE PIPE, FLEX PIPE CONNECTORS,	(49.43)	
06/06/2023	INVOICE	86651	7 BLADE TRAILER SIDE	9.49	
06/06/2023	INVOICE	86565	FENDER WASHER, LAG SCREW, 4X4-12' AC2 GREEN	49.38	
06/06/2023	INVOICE	86591	STENCIL, FENCE BRACKET, WASHERS, LAG SCREW,	68.19	

Vendor Code Post Date	Vendor Name Activity	Inv/Check #	Description	Invoice Amt	Check Amt
06/06/2023	INVOICE	86514	GAS CANS, BRIGGS 2 STROKE, ACTIVARMR GEN PUI	60.53	
06/06/2023	INVOICE	86516	20" FLOOR FANS, STORAGE CART-ARPA FUNDS	269.95	
06/06/2023	INVOICE	86429	BATTERY TRANSFER PUMP	12.99	
06/06/2023	INVOICE	85469	2.5 GAL DEF	113.76	
06/06/2023	INVOICE	85499	4-LVL RACK, 16QT CRATE, 40 GALLON TOTE	696.88	
06/06/2023	INVOICE	85465	FURNANCE PIPE, FLEX PIPE CONNECTOR, GALV ELI	114.66	
06/06/2023	INVOICE	85334	9 - DAWN 750Z	42.48	
06/06/2023	INVOICE	85407	BLUE TOWELS, IRISH SPRING, MOTH BALLS	30.94	
06/06/2023	INVOICE	85418	ELECTAPE, PVC COUPLER, HEAT SHRINK TUBE, SP	119.43	
06/06/2023	INVOICE	85411	DRYER CORD	51.98	
06/06/2023	INVOICE	85406	WASH & WAX, STOPLEAK, FUEL PREMIX, TOTES	217.63	
06/06/2023	INVOICE	85532	ENR RECHARGEABLE D-2	68.80	
06/06/2023	INVOICE	85547	MF-SKT 3/4 DR 12PT	21.98	
06/06/2023	INVOICE	86127	COMPRESSION INSERT & SLEEVE, VACUUM BREAKER,	18.23	
06/06/2023	INVOICE	85827	METAL SAWTOOTH, SLEEK DOCUMENT BK	35.72	
06/06/2023	INVOICE	85946	128OZ CLR, WHISK BROOM, RATCH WRN	42.05	
06/06/2023	INVOICE	85978	30" WIRE EASEL, PADLOCK	23.98	
06/06/2023	INVOICE	86038	REDUCER, HOSE REPAIR KIT, PVC AIR HOSE, PEAL	79.92	
Total:				2,099.54	
Net of 22 Invoices / 0 Checks				2,099.54	
02334	MICHAEL TODD & COMPANY INC				
06/06/2023	INVOICE	209992	ELGIN EAGLE/BROOM BEAR TUBE 60"	708.07	
Total:				708.07	
Net of 1 Invoices / 0 Checks				708.07	
03222	MID-AMERICAN RESEARCH				
06/06/2023	INVOICE	0791155-IN	BOWL CLEANER	150.00	
Total:				150.00	
Net of 1 Invoices / 0 Checks				150.00	
02245	MID-IOWA SOLID WASTE				
06/06/2023	INVOICE	58648	4 SEGMENT GUTTER BROOM	524.54	
06/06/2023	INVOICE	58584	STREET SWEEPER	345,100.00	
Total:				345,624.54	
Net of 2 Invoices / 0 Checks				345,624.54	
00205	MID-STATE ENGINEERING & TESTING				
06/06/2023	INVOICE	187-0	LOST CREEK PARKWAY SEWER & WATER MAIN	902.50	
06/06/2023	INVOICE	204-0	COLUMBUS PAVING IMPROVEMENTS SID 189	572.50	
Total:				1,475.00	
Net of 2 Invoices / 0 Checks				1,475.00	
00487	MIDWEST TAPE LLC				
06/06/2023	INVOICE	503813721	MATERIALS	65.97	
06/06/2023	INVOICE	503780862	MATERIALS	64.47	
06/06/2023	INVOICE	503846525	DVD	14.24	
Total:				144.68	
Net of 3 Invoices / 0 Checks				144.68	

Vendor Code Post Date	Vendor Name Activity	Inv/Check #	Description	Invoice Amt	Check Amt
03227 06/06/2023	MIDWEST TURF & IRRIGATION INVOICE	3910229-00	ADJUSTABLE FLAG KEY, UTILITY TOOL, VLAVE REI	652.80	
			Total:	652.80	
			Net of 1 Invoices / 0 Checks	652.80	
10752 06/06/2023	MOMS & MOPS INVOICE	5.25.2023	CLEANING CENTRAL MAINTENANCE	400.00	
			Total:	400.00	
			Net of 1 Invoices / 0 Checks	400.00	
03230 06/06/2023	MOTION INDUSTRIES INC INVOICE	NE07-00487438	CORDED FOAM EARPLUGS	52.21	
			Total:	52.21	
			Net of 1 Invoices / 0 Checks	52.21	
10832 06/06/2023	MR GOLF CAR INC INVOICE	41093	RENTAL/TOURNAMENT CARS ON 5/20/23	1,920.00	
			Total:	1,920.00	
			Net of 1 Invoices / 0 Checks	1,920.00	
00153 06/06/2023	MUELLER SPRINKLERS INVOICE	90802	SWITCH-PTO	51.99	
			Total:	51.99	
			Net of 1 Invoices / 0 Checks	51.99	
11018 06/06/2023	MW MINI MELTS LLC INVOICE	1046	MINI MELTS	2,726.00	
			Total:	2,726.00	
			Net of 1 Invoices / 0 Checks	2,726.00	
10225 06/06/2023	NAPA AUTO PARTS OF COLUMBUS INVOICE	732697	BATTERY	163.98	
06/06/2023	INVOICE	733024	BATTERY	137.82	
06/06/2023	INVOICE	733129	OIL & AIR FILTER	78.23	
06/06/2023	INVOICE	732671	FUEL FILTER	10.99	
06/06/2023	INVOICE	732620	BATTERY	163.98	
06/06/2023	INVOICE	732414	BATTERY	137.82	
06/06/2023	INVOICE	732668	HOSE END FIITTING, WEATHERSHIELD EN HOS	93.45	
			Total:	786.27	
			Net of 7 Invoices / 0 Checks	786.27	
02249 06/06/2023	NEBRASKA FIRE SPRINKLER CORP INVOICE	9909	ANNUAL FIRE SPRINKLER INSPECTION	295.00	
06/06/2023	INVOICE	9908	ANNUAL FIRE SPRINKLER INSPECTION	440.00	
			Total:	735.00	
			Net of 2 Invoices / 0 Checks	735.00	
00140	NEBRASKA GOLF & TURF INC				

Vendor Code Post Date	Vendor Name Activity	Inv/Check #	Description	Invoice Amt	Check Amt
06/06/2023	INVOICE	02-140998	SPEED SENSOR - SERVICE PACKAGE	467.19	
06/06/2023	INVOICE	02-142557	GASKETS, FUEL TANK CAP, FUEL PUMP KIT, CARBU	222.09	
			Total:	689.28	
			Net of 2 Invoices / 0 Checks	689.28	
00444	NEBRASKA PUBLIC HEALTH				
06/06/2023	INVOICE	564774	WATER TESTING	1,428.00	
			Total:	1,428.00	
			Net of 1 Invoices / 0 Checks	1,428.00	
00039	NEBRASKA RURAL WATER ASSOC				
06/06/2023	INVOICE	2023	MEMBERSHIP RENEWAL	550.00	
			Total:	550.00	
			Net of 1 Invoices / 0 Checks	550.00	
00029	NEBRASKA STATE FIRE MARSHAL				
06/06/2023	INVOICE	128111	ANNUAL BOILER CERTIFICATE PAWNEE PLUNGE	72.00	
			Total:	72.00	
			Net of 1 Invoices / 0 Checks	72.00	
10723	NEBRASKALAND NATIONAL BANK				
06/06/2023	INVOICE	68701	LOAN PAYMENT	42,499.99	
			Total:	42,499.99	
			Net of 1 Invoices / 0 Checks	42,499.99	
03241	NEWMAN SIGNS INC.				
06/06/2023	INVOICE	TRFINV046774	SIGNS	1,430.85	
06/06/2023	INVOICE	TRFINV046759	SIGNS	80.96	
			Total:	1,511.81	
			Net of 2 Invoices / 0 Checks	1,511.81	
MISC	NIELSEN TONY & KAREN				
06/06/2023	INVOICE	05/17/2023	UB refund for account: 200-33000-00	69.33	
			Total:	69.33	
			Net of 1 Invoices / 0 Checks	69.33	
03246	NORTHEAST NEBRASKA ECONOMIC				
06/06/2023	INVOICE	24618	DHA TRUST REUSE APRIL 2023 ADMIN SERVICES	18.75	
06/06/2023	INVOICE	24609	CDBG REHAB REUSE APRIL 2023 ADMIN SERVICES	18.75	
06/06/2023	INVOICE	24600	CDBG DHA REUSE APRIL 2023 ADMIN SERVICES	75.00	
06/06/2023	INVOICE	24066	19-DTR-101 NOVEMBER 2022 SERVICES	151.22	
			Total:	263.72	
			Net of 4 Invoices / 0 Checks	263.72	
03247	NORTHWEST ELECTRIC LLC				
06/06/2023	INVOICE	716882	REPAIR MOTOR - PP PUMP LAP	4,689.24	
06/06/2023	INVOICE	716909	BLEW OUT/FREED UP SWITCH	75.00	
06/06/2023	INVOICE	716856	REPAIR MOTOR	1,250.88	

Vendor Code Post Date	Vendor Name Activity	Inv/Check #	Description	Invoice Amt	Check Amt
			Total:	6,015.12	
			Net of 3 Invoices / 0 Checks	6,015.12	
11010 06/06/2023	NPAS INC INVOICE	080039	REPAIR	663.35	
			Total:	663.35	
			Net of 1 Invoices / 0 Checks	663.35	
00358 06/06/2023	OBRIST & CO INC INVOICE	13282	INSTALL 50 GALLON GAS WATER HEATER	2,600.00	
06/06/2023	INVOICE	13223	REPLACE ORING IN TOILET	153.00	
			Total:	2,753.00	
			Net of 2 Invoices / 0 Checks	2,753.00	
03249 06/06/2023	OCCUPATIONAL HEALTH SERV INVOICE	1790	COLLECTION & TESTING	67.00	
06/06/2023	INVOICE	1712	COLLECTION & TESTING	2,403.00	
06/06/2023	INVOICE	1877	COLLECTION & TESTING	1,733.00	
			Total:	4,203.00	
			Net of 3 Invoices / 0 Checks	4,203.00	
00176 06/06/2023	O'REILLY AUTOMOTIVE INC INVOICE	0681-218825	PINTLE COMBO, PLATE, PIN & CLIP	203.97	
06/06/2023	INVOICE	0681-218081	COP COILS	712.60	
06/06/2023	INVOICE	0681-197636	RETURN - FUEL FILTERS	(80.40)	
06/06/2023	INVOICE	0681-221594	TOWING KIT, SECURITY KIT, PIN & CLIP	106.96	
06/06/2023	INVOICE	0681-219803	RV ANTIFREZE	12.98	
06/06/2023	INVOICE	0681-221287	3.3 OZ ELEC GRS	29.98	
06/06/2023	INVOICE	0681-223250	MINI LAMP	4.71	
06/06/2023	INVOICE	0681-223251	MINI LAMP	12.58	
06/06/2023	INVOICE	0681-224246	BATTERY	140.38	
			Total:	1,143.76	
			Net of 9 Invoices / 0 Checks	1,143.76	
10411 06/06/2023	PAPER TIGER SHREDDING INVOICE	179807	SHREDDING EVENT-/REIMBURSED FROM NENAAA GRAI	235.80	
			Total:	235.80	
			Net of 1 Invoices / 0 Checks	235.80	
01869 06/06/2023	PERFORMANCE PRINTING INC INVOICE	27781 (B)	JODI HEFTI NOTARY STAMP	38.22	
			Total:	38.22	
			Net of 1 Invoices / 0 Checks	38.22	
00345 06/06/2023	PETE LIEN & SONS INC. INVOICE	CD99052609	QUICKLIME FINES	7,004.80	
06/06/2023	INVOICE	CD99056584	QUICKLIME FINES	7,732.70	
			Total:	14,737.50	

Vendor Code Post Date	Vendor Name Activity	Inv/Check #	Description	Invoice Amt	Check Amt
			Net of 2 Invoices / 0 Checks	14,737.50	
03258	PETTY CASH				
06/06/2023	INVOICE	809837	ICE, DONUTS FOR MEETING	13.51	
06/06/2023	INVOICE	53023POLICE	PETTY CASH	105.00	
06/06/2023	INVOICE	68411	DISTILLED WATER	1.35	
06/06/2023	INVOICE	5.23.2023	REIMBURSE FOR TRASH BAGS	9.66	
			Total:	129.52	
			Net of 4 Invoices / 0 Checks	129.52	
10942	PHENOVA INC				
06/06/2023	INVOICE	193780	WP MICRO QUANTITATIVE	217.20	
06/06/2023	INVOICE	193589	WP DEMAND, SOLIDS, NUTRIENTS SET, NITRITE, (544.94	
			Total:	762.14	
			Net of 2 Invoices / 0 Checks	762.14	
10736	PLATTE VALLEY PRECAST INC				
06/06/2023	INVOICE	1	AIRPORT HANGER	43,159.95	
			Total:	43,159.95	
			Net of 1 Invoices / 0 Checks	43,159.95	
10241	POMP'S TIRE SERVICE INC.				
06/06/2023	INVOICE	1440017327	TIRE REPAIR	213.26	
06/06/2023	INVOICE	1440017326	USED TRUCK TIRE, USED WHEEL BUDD	283.71	
06/06/2023	INVOICE	1440017169	USED TRUCK TIRE	97.00	
06/06/2023	INVOICE	1440017154	4 TIRES - TRUCK #20	1,717.52	
06/06/2023	INVOICE	1440016748	TIRE REPAIR	44.80	
06/06/2023	INVOICE	1440016793	TIRE REPAIR	135.00	
06/06/2023	INVOICE	1440016794	TIRE REPAIR	208.00	
06/06/2023	INVOICE	1440016812	TIRE REPAIR	290.00	
06/06/2023	INVOICE	1440016728	2 - USED TRUCK TIRES	418.40	
06/06/2023	INVOICE	1440016729	FLAT REPAIR	138.03	
06/06/2023	INVOICE	1440017261	TIRE REPAIR	150.58	
			Total:	3,696.30	
			Net of 11 Invoices / 0 Checks	3,696.30	
11012	PREFERRED PIPELINE LLC				
06/06/2023	INVOICE	PPL000069408	SAND	796.80	
			Total:	796.80	
			Net of 1 Invoices / 0 Checks	796.80	
03261	PRESTOX				
06/06/2023	INVOICE	44683209	PEST CONTROL - 4630 HOWARD BLVD	57.63	
			Total:	57.63	
			Net of 1 Invoices / 0 Checks	57.63	
00189	PRODUCTIVITY PLUS ACCOUNT-CNH				
06/06/2023	INVOICE	1517996A	ELEC CONT UNIT, REMANSENSOR	1,123.02	
06/06/2023	INVOICE	1517996 CL	RETURN PART - ELEC CONT UNIT	(174.00)	

Vendor Code Post Date	Vendor Name Activity	Inv/Check #	Description	Invoice Amt	Check Amt
			Total:	949.02	
			Net of 2 Invoices / 0 Checks	949.02	
00493	PSYCHOLOGICAL RESOURCES				
06/06/2023	INVOICE	2305065	PSYCHOLOGICAL EVALUATION - FRENCH & CLOETER	300.00	
			Total:	300.00	
			Net of 1 Invoices / 0 Checks	300.00	
10416	QUADIENT LEASING USA, INC.				
06/06/2023	INVOICE	N9948368	QUARTERLY MACHINE LEASE PAYMENT	642.63	
			Total:	642.63	
			Net of 1 Invoices / 0 Checks	642.63	
01279	QUINN JEFF				
06/06/2023	INVOICE	5.02.2023	SUMMER READING PROGRAM MAGIC SHOW	300.00	
			Total:	300.00	
			Net of 1 Invoices / 0 Checks	300.00	
03264	REARDON LAWN & GARDEN INC				
06/06/2023	INVOICE	3841	OPTI-2 1.8OZ	23.94	
06/06/2023	INVOICE	3723	SWITCH, CABLE ASSY	31.98	
06/06/2023	INVOICE	4055	AIR FILTER, FILTER	47.96	
06/06/2023	INVOICE	3934	MOWER, TRIMMER, HAND HELD BLOWER	1,967.96	
			Total:	2,071.84	
			Net of 4 Invoices / 0 Checks	2,071.84	
10619	RIVER VALLEY TIRE SERVICE LLC				
06/06/2023	INVOICE	940013	TRAILER TIRE REPAIR	15.00	
			Total:	15.00	
			Net of 1 Invoices / 0 Checks	15.00	
10643	RUTT'S HEATING & A/C INC				
06/06/2023	INVOICE	10510	CHECKED HEAT PUMPS	450.00	
			Total:	450.00	
			Net of 1 Invoices / 0 Checks	450.00	
10793	SAND CREEK CONSTRUCTION COMPANY				
06/06/2023	INVOICE	108	DESIGN BUILD FAMILY WATER SLIDE	2,500.00	
06/06/2023	INVOICE	109	GERRARD PARK TENNIS & PICKLEBALL COURT RENO'	11,750.00	
			Total:	14,250.00	
			Net of 2 Invoices / 0 Checks	14,250.00	
03270	SAPP BROS COLUMBUS INC				
06/06/2023	INVOICE	IN4165561	FUEL	4,452.03	
06/06/2023	INVOICE	IN4164588	FUEL	2,898.14	
06/06/2023	INVOICE	IN4168375	AMERIGUARD 15W-40 HD & HYDRAULIC	1,456.00	
06/06/2023	INVOICE	IN4158710	FUEL	6,739.42	
06/06/2023	INVOICE	IN4159173	FUEL	11,051.00	
06/06/2023	INVOICE	IN4160814	FUEL	2,357.88	

Vendor Code Post Date	Vendor Name Activity	Inv/Check #	Description	Invoice Amt	Check Amt
06/06/2023	INVOICE	IN4154594	FUEL	5,733.00	
			Total:	34,687.47	
			Net of 7 Invoices / 0 Checks	34,687.47	
02805 06/06/2023	SCHEMMER ASSOCIATES INC. INVOICE	09071.001-2	23RD ST WATER & SEWER CONSTRUCTION INSPECTIO	14,108.14	
			Total:	14,108.14	
			Net of 1 Invoices / 0 Checks	14,108.14	
03271 06/06/2023	SCHIEFFER SIGNS INC INVOICE	45686	METAL SIGN	432.00	
06/06/2023	INVOICE	45626	SIGNS, WIRE STANDS	1,156.50	
			Total:	1,588.50	
			Net of 2 Invoices / 0 Checks	1,588.50	
03273 06/06/2023	SCHOOL DISTRICT #1 INVOICE	SCHOOLS	LIQUOR AND TOBACCO REVENUE PAYMENT	15,502.50	
			Total:	15,502.50	
			Net of 1 Invoices / 0 Checks	15,502.50	
00156 06/06/2023	SEALOCK GREG INVOICE	5132023POLICE	PRE-EMPLOYMENT POLYGRAPH - J FRENCH	125.00	
			Total:	125.00	
			Net of 1 Invoices / 0 Checks	125.00	
10726 06/06/2023	SEILER INSTRUMENT & MFG CO INC INVOICE	INV6491	GROUND CONTROL POINT 5 PACK	399.99	
			Total:	399.99	
			Net of 1 Invoices / 0 Checks	399.99	
00465 06/06/2023	SERVICEMASTER BY SHEVLIN INVOICE	10117	JANITORIAL SERVICES	2,413.00	
06/06/2023	INVOICE	10110	JANITORIAL SERVICES	2,075.00	
06/06/2023	INVOICE	10113	JANITORIAL SERVICES	2,095.00	
			Total:	6,583.00	
			Net of 3 Invoices / 0 Checks	6,583.00	
03276 06/06/2023	SHERWIN-WILLIAMS CO INVOICE	4509-8	REPAIR KIT	153.00	
06/06/2023	INVOICE	582423	QP EASY OUT FLT	17.99	
			Total:	170.99	
			Net of 2 Invoices / 0 Checks	170.99	
01090 06/06/2023	SHEVLIN SUPPLY INVOICE	6669	TOILET TISSUE	366.20	
06/06/2023	INVOICE	6670	TOWEL WHITE, CENTER PULL TOWEL	73.68	
06/06/2023	INVOICE	6694	CENTER PULL TOWEL,BATH TISSUE, NITRILE GLOV	838.14	

Vendor Code Post Date	Vendor Name Activity	Inv/Check #	Description	Invoice Amt	Check Amt
			Total:	1,278.02	
			Net of 3 Invoices / 0 Checks	1,278.02	
01394	SIRIUS COMPUTER SOLUTIONS INC.				
06/06/2023	INVOICE	INV-000952463	CITY PARKS - OUTDOOR WIRELESS	839.47	
06/06/2023	INVOICE	INV-000952876	CITY PARKS - OUTDOOR WIRELESS	337.98	
			Total:	1,177.45	
			Net of 2 Invoices / 0 Checks	1,177.45	
10595	STANARD & ASSOCIATES INC.				
06/06/2023	INVOICE	SA000054219	LAW ENFORCEMENT OFFICER SELECTION TEST	143.00	
			Total:	143.00	
			Net of 1 Invoices / 0 Checks	143.00	
00244	STERICYCLE INC				
06/06/2023	INVOICE	4011789716	MEDICAL WASTE SERVICES	1,061.33	
			Total:	1,061.33	
			Net of 1 Invoices / 0 Checks	1,061.33	
00089	STRECKER BRET				
06/06/2023	INVOICE	TUITION	TUITION REIMBURSEMENT 2023	500.00	
			Total:	500.00	
			Net of 1 Invoices / 0 Checks	500.00	
10579	STREET COP TRAINING				
06/06/2023	INVOICE	INV-99201	NEBRASKA CASE LAW	199.00	
06/06/2023	INVOICE	INV-99203	NEBRASKA CASE LAW - VENZOR & MCCLOUD	398.00	
			Total:	597.00	
			Net of 2 Invoices / 0 Checks	597.00	
02720	STRING BEANS LTD				
06/06/2023	INVOICE	1.11.2023	SUMMER READING PROGRAM	975.00	
			Total:	975.00	
			Net of 1 Invoices / 0 Checks	975.00	
00105	SUPER SAVER				
06/06/2023	INVOICE	121842	HAMBURGER BUNS	15.42	
06/06/2023	INVOICE	122330	POP & POWERADE FOR CONCESSIONS	112.12	
06/06/2023	INVOICE	122189	GROCERIES, SANDWICH BAGS, SCOURING PAD	52.57	
			Total:	180.11	
			Net of 3 Invoices / 0 Checks	180.11	
00110	SYSCO LINCOLN				
06/06/2023	INVOICE	461979583	GROCERIES, FOAM CONTAINERS	2,151.46	
06/06/2023	INVOICE	461970810	GROCERIES, FOAM CONTAINERS	167.21	
06/06/2023	INVOICE	461992426	GROCERIES, FOAM CUPS, LIDS	2,210.60	
06/06/2023	INVOICE	561003969	GROCERIES, FOAM CONTAINERS	2,893.22	
06/06/2023	INVOICE	561006654	CREDIT - MILK, BAKING POTATOES	(52.84)	
06/06/2023	INVOICE	561017625	GROCERIES, 4OZ CUPS, COFFEE	1,352.91	

Vendor Code Post Date	Vendor Name Activity	Inv/Check #	Description	Invoice Amt	Check Amt
06/06/2023	INVOICE	561003971	CONCESSIONS	4,838.47	
06/06/2023	INVOICE	561007148	CONCESSIONS	1,814.81	
06/06/2023	INVOICE	561006656	RETURN	(519.71)	
06/06/2023	INVOICE	561009958	BUTTER MIST	50.89	
06/06/2023	INVOICE	561014970	CONCESSIONS	1,563.56	
06/06/2023	INVOICE	561017627	CONCESSIONS	2,698.31	
Total:				19,168.89	
Net of 12 Invoices / 0 Checks				19,168.89	
10987	THE GOLF SHOP				
06/06/2023	INVOICE	143381	55-60 GALLON TRASH BAGS ON ROLLS	421.52	
Total:				421.52	
Net of 1 Invoices / 0 Checks				421.52	
10326	THE LIFEGUARD STORE				
06/06/2023	INVOICE	INV001307739	UNIFORMS	7,253.50	
Total:				7,253.50	
Net of 1 Invoices / 0 Checks				7,253.50	
03128	TIRE OUTLET INC				
06/06/2023	INVOICE	224017	MOUNT & DISPOSAL	10.00	
06/06/2023	INVOICE	223845	USED TIRE	45.00	
06/06/2023	INVOICE	223843	TIRE	236.00	
06/06/2023	INVOICE	224669	ROTATE	25.00	
06/06/2023	INVOICE	224400	4 -TIRES, 4 - TUBES	744.00	
06/06/2023	INVOICE	224347	TUBE	85.00	
Total:				1,145.00	
Net of 6 Invoices / 0 Checks				1,145.00	
10803	TOBY KID KLAUENBERG				
06/06/2023	INVOICE	475	PRO-READING COMEDY SHOW	545.00	
Total:				545.00	
Net of 1 Invoices / 0 Checks				545.00	
10588	TOO FAST SUPPLY				
06/06/2023	INVOICE	390009	DIAMOND BLADE	65.84	
Total:				65.84	
Net of 1 Invoices / 0 Checks				65.84	
00550	TRUCK CENTER COMPANIES				
06/06/2023	INVOICE	XA111028476:01	DRAIN VALVE	10.72	
06/06/2023	INVOICE	XA111028573:01	QUICK RELEASE VALVE	71.98	
06/06/2023	INVOICE	XA111028637:01	COMBO BULK W/CLEVIS	39.95	
06/06/2023	INVOICE	XA111028583:01	1 GAL LIQUITUBE W/PUMP	62.15	
Total:				184.80	
Net of 4 Invoices / 0 Checks				184.80	
00357	TURFWERKS				
06/06/2023	INVOICE	OI54652	SVC-WLDMT, BRG-BALL, BEARING, WASHER, ELBOW	2,447.74	

Vendor Code Post Date	Vendor Name Activity	Inv/Check #	Description	Invoice Amt	Check Amt
			Total:	2,447.74	
			Net of 1 Invoices / 0 Checks	2,447.74	
00100	U & I SANITATION				
06/06/2023	INVOICE	8853-294	APRIL SERVICE	50.00	
06/06/2023	INVOICE	8859-297	MAY SERVICE	50.00	
06/06/2023	INVOICE	8859-398	MAY GARBAGE SERVICE	85.00	
			Total:	185.00	
			Net of 3 Invoices / 0 Checks	185.00	
03294	USA BLUE BOOK				
06/06/2023	INVOICE	INV00009976	PERSONAL LOCKOUT KITS	465.81	
06/06/2023	INVOICE	INV00014861	MAINTENACNE KIT FOR CL 17	612.56	
06/06/2023	INVOICE	INV00007858	HACH FLORIDE, TOTAL PHOSPHATE TNT SET, CELL	1,463.59	
06/06/2023	INVOICE	INV00006369	LOCKOUT KITS	431.90	
			Total:	2,973.86	
			Net of 4 Invoices / 0 Checks	2,973.86	
02280	VOICE HOUSE				
06/06/2023	INVOICE	5.10.2023	LAWN CHAIRS ON THE SQUARE PERFORMANCE	1,750.00	
06/06/2023	INVOICE	5.17.2023	SOUND & LIGHTS FOR DANCE GROUPS AT LAWNCHAI	350.00	
			Total:	2,100.00	
			Net of 2 Invoices / 0 Checks	2,100.00	
03023	WELDON PARTS NORTH BEND				
06/06/2023	INVOICE	2987942-00	AIR BAG	136.32	
			Total:	136.32	
			Net of 1 Invoices / 0 Checks	136.32	
03303	WILKE LANDSCAPE CENTER				
06/06/2023	INVOICE	2606	PLANTS	399.45	
			Total:	399.45	
			Net of 1 Invoices / 0 Checks	399.45	
01444	ZEGERS AUTOMOTIVE				
06/06/2023	INVOICE	46532	REPAIR A/C	561.05	
			Total:	561.05	
			Net of 1 Invoices / 0 Checks	561.05	
00215	ZIMCO SUPPLY CO				
06/06/2023	INVOICE	179208	ARMAMENT, ARMOR TECH, IPRODIONE, STRESSGARD,	4,859.50	
06/06/2023	INVOICE	180505	STN+ARMAMENT 50# BAG	4,560.00	
			Total:	9,419.50	
			Net of 2 Invoices / 0 Checks	9,419.50	
MISC	ZIMMERER BRENTON				
06/06/2023	INVOICE	05/25/2023	UB refund for account: 200-37200-03	48.46	

Vendor Code Post Date	Vendor Name Activity	Inv/Check #	Description	Invoice Amt	Check Amt
			Total:	48.46	
			Net of 1 Invoices / 0 Checks	48.46	
			invoices and 0 checks for 165 vendors:	<u>1,848,938.98</u>	<u> </u>

Inv Ref#	Vendor	Inv Date	Due Date	Inv Amt	Amt Due	Status	Jrnlized
87878	GILMORE & ASSOCIATES INC	05/10/2023	06/06/2023	7,000.00	7,000.00	Open	N
87888	PETE LIEN & SONS INC.	05/16/2023	06/06/2023	7,004.80	7,004.80	Open	N
87914	SAPP BROS COLUMBUS INC	05/12/2023	06/06/2023	6,739.42	6,739.42	Open	N
87917	SAPP BROS COLUMBUS INC	05/08/2023	06/06/2023	5,733.00	5,733.00	Open	N
87942	THE LIFE GUARD STORE	05/14/2023	06/06/2023	7,253.50	7,253.50	Open	N
88079	MACQUEEN EQUIPMENT	04/18/2023	06/06/2023	7,082.95	7,082.95	Open	N
88157	PETE LIEN & SONS INC.	05/29/2023	06/06/2023	7,732.70	7,732.70	Open	N
88168	HAWKINS INC	05/26/2023	06/06/2023	6,227.75	6,227.75	Open	N
# of Invoices:	8	# Due:	8	Totals:	54,774.12	54,774.12	
# of Credit Memos:	0	# Due:	0	Totals:	0.00	0.00	
Net of Invoices and Credit Memos:					54,774.12	54,774.12	

--- TOTALS BY FUND ---

100 - GENERAL FUND	12,986.50	12,986.50
200 - STREETS/ENGINEERING	7,082.95	7,082.95
500 - UTILITY SERVICE	21,737.50	21,737.50
520 - WATER	6,227.75	6,227.75
570 - SOLID WASTE DIVISION	6,739.42	6,739.42

--- TOTALS BY DEPT/ACTIVITY ---

110 - POLICE	5,733.00	5,733.00
151 - PAWNEE PLUNGE WATER PARK	6,900.00	6,900.00
152 - AQUATIC CENTER POOL	353.50	353.50
200 - STREETS	7,082.95	7,082.95
500 - WASTEWATER COLLECTION	7,000.00	7,000.00
501 - WASTEWATER TREATMENT FAC	14,737.50	14,737.50
520 - WATER	6,227.75	6,227.75
570 - TRANSFER STATION	6,739.42	6,739.42

UNJOURNALIZED
 BOTH OPEN AND PAID

GL Number	Invoice Line Desc	Vendor	Invoice Description	Amount	Check #
Fund 100 GENERAL FUND					
Dept 100 GENERAL ADMINISTRATION					
100-100-53200	PROFESSIONAL SERVICES	BAIRD HOLM LLP	DISTRICT TIF	3,022.00	
100-100-53400	COMPUTER SUPPORT/MAINT	LABORDE, ADAM	GIS SUPPORT SERVICES MARCH/APRIL 2023	195.00	
100-100-54310	BUILDING MAINTENANCE	ACE HARDWARE & GARDEN CNT	AIR FILTER	20.97	
100-100-54310	BUILDING MAINTENANCE	ARNOLD MOTOR SUPPLY	HI-POWER II V-BELT	14.68	
100-100-54310	BUILDING MAINTENANCE	JACKSON SERVICES INC	MATS	126.85	
100-100-54310	BUILDING MAINTENANCE	RUTT'S HEATING & A/C INC	CHECKED HEAT PUMPS	450.00	
100-100-56010	SUPPLIES	EAKES OFFICE SOLUTIONS	WIPES	25.99	
100-100-56010	SUPPLIES	PETTY CASH	ICE, DONUTS FOR MEETING	14.86	
100-100-56010	SUPPLIES	SHEVLIN SUPPLY	TOWEL WHITE, CENTER PULL TOWEL	73.68	
100-100-56020	OFFICE SUPPLIES	EAKES OFFICE SOLUTIONS	PENS, REFILLS	82.83	
100-100-56030	CLEANING SUPPLIES/SERVICE	SERVICEMASTER BY SHEVLIN	JANITORIAL SERVICES	2,075.00	
100-100-56040	POSTAGE AND FREIGHT	CASEY'S MAIL SERVICE LLC	DAILY POSTAGE, WATER STATEMENTS	127.76	
100-100-56040	POSTAGE AND FREIGHT	QUADIENT LEASING USA, INC.	QUARTERLY MACHINE LEASE PAYMENT	642.63	
100-100-56230	WATER AND SEWER	CITY OF COLUMBUS	WATER & SEWER	89.97	
100-100-56240	TELEPHONE	FRONTIER	TELEPHONE NEW BUILDING - 5/13/23 TO 6/1	135.87	
100-100-56240	TELEPHONE	GREAT PLAINS COMMUNICATION	PHONE/INTERNET CHARGES 05/16 - 06/15	144.81	
100-100-57200-20003	CAPITAL-LAND & BUILDINGS	JEO CONSULTING GROUP INC	FLOOD MITIGATION & RESILIENCY PLAN	21,388.60	
100-100-57510	CAPITAL-EQUIPMENT	CDW GOVERNMENT	MIC ROSOFT WINDOWS SERVER	871.94	
100-100-57510-19009	CAPITAL-EQUIPMENT	SIRIUS COMPUTER SOLUTIONS	CITY PARKS - OUTDOOR WIRELESS	1,177.45	
Total For Dept 100 GENERAL ADMINISTRATION				30,680.89	
Dept 102 COLUMBUS AREA TRANSIT					
100-102-54330	VEHICLE MAINTENANCE	ARNOLD MOTOR SUPPLY	OIL FILTER, PM 5W30 SYN BLEND	54.02	
100-102-54330	VEHICLE MAINTENANCE	TIRE OUTLET INC	ROTATE	25.00	
100-102-54330	VEHICLE MAINTENANCE	ZEGERS AUTOMOTIVE	REPAIR A/C	561.05	
100-102-56020	OFFICE SUPPLIES	EAKES OFFICE SOLUTIONS	COPIER CONTRACT	241.61	
100-102-56230	WATER AND SEWER	CITY OF COLUMBUS	WATER & SEWER	95.68	
100-102-56240	TELEPHONE	GREAT PLAINS COMMUNICATION	PHONE/INTERNET CHARGES 05/16 - 06/15	14.60	
Total For Dept 102 COLUMBUS AREA TRANSIT				991.96	
Dept 103 COLUMBUS SENIOR CENTER					
100-103-55900	MISCELLANEOUS	PAPER TIGER SHREDDING	SHREDDING EVENT-/REIMBURSED FROM NENAAF	235.80	
100-103-56010	SUPPLIES	EAKES OFFICE SOLUTIONS	SHREDDER LUBRICANT-ARPA FUNDS	299.98	
100-103-56010	SUPPLIES	MENARDS	20" FLOOR FANS, STORAGE CART-ARPA FUNDS	269.95	
100-103-56010-III-B	SUPPLIES	SYSCO LINCOLN	GROCERIES, FOAM CUPS, LIDS	84.24	
100-103-56010-III-C	SUPPLIES	SUPER SAVER	GROCERIES, SANDWICH BAGS, SCOURING PAD	12.90	
100-103-56010-III-C	SUPPLIES	SYSCO LINCOLN	GROCERIES, FOAM CONTAINERS	203.98	
100-103-56020-III-B	OFFICE SUPPLIES	EAKES OFFICE SOLUTIONS	CORRECTION TAPE	9.98	
100-103-56020-III-C	OFFICE SUPPLIES	EAKES OFFICE SOLUTIONS	CORRECTION TAPE	9.98	
100-103-56030-III-B	CLEANING SUPPLIES/SERVICE	JACKSON SERVICES INC	MAT	13.41	
100-103-56030-III-C	CLEANING SUPPLIES/SERVICE	JACKSON SERVICES INC	MAT	13.41	
100-103-56030-III-C	CLEANING SUPPLIES/SERVICE	SUPER SAVER	GROCERIES, SANDWICH BAGS, SCOURING PAD	26.80	
100-103-56240	TELEPHONE	GREAT PLAINS COMMUNICATION	PHONE/INTERNET CHARGES 05/16 - 06/15	36.50	
100-103-56300-III-C	FOOD COSTS	SUPER SAVER	HAMBURGER BUNS	28.29	
100-103-56300-III-C	FOOD COSTS	SYSCO LINCOLN	GROCERIES, FOAM CONTAINERS	8,434.34	
Total For Dept 103 COLUMBUS SENIOR CENTER				9,679.56	
Dept 105 FINANCE					
100-105-52710	EMPLOYEE RECRUITMENT/RETENTION	OCCUPATIONAL HEALTH SERV	COLLECTION & TESTING	230.00	
100-105-56240	TELEPHONE	GREAT PLAINS COMMUNICATION	PHONE/INTERNET CHARGES 05/16 - 06/15	36.50	
Total For Dept 105 FINANCE				266.50	
Dept 106 CITY CLERK					

UNJOURNALIZED
 BOTH OPEN AND PAID

GL Number	Invoice Line Desc	Vendor	Invoice Description	Amount	Check #
Fund 100 GENERAL FUND					
Dept 106 CITY CLERK					
100-106-52700	TRAINING AND TUITION	LEAGUE OF NEBR MUNICIPALIT	2023 MUNICIPAL ACCOUNTING & FINANCE CON	535.00	
100-106-56240	TELEPHONE	GREAT PLAINS COMMUNICATION	PHONE/INTERNET CHARGES 05/16 - 06/15	29.20	
100-106-56650	MEMBERSHIP DUES	INTERNATL INSTITUTE OF	ANNUAL MEMBERSHIP - JANELLE KLINE, KELI	350.00	
Total For Dept 106 CITY CLERK				914.20	
Dept 108 HUMAN RESOURCES					
100-108-56240	TELEPHONE	GREAT PLAINS COMMUNICATION	PHONE/INTERNET CHARGES 05/16 - 06/15	7.30	
Total For Dept 108 HUMAN RESOURCES				7.30	
Dept 110 POLICE					
100-110-52700	TRAINING AND TUITION	HADLEY-BRAITHWAIT COMPANY	2 CASES COFFEE FILTERS	15.75	
100-110-52700	TRAINING AND TUITION	LEVANDER JAYMEE	TUITION REIMBURSEMENT	500.00	
100-110-52700	TRAINING AND TUITION	PERFORMANCE PRINTING INC	JODI HEFTI NOTARY STAMP	38.22	
100-110-52700	TRAINING AND TUITION	PETTY CASH	PETTY CASH	95.45	
100-110-52700	TRAINING AND TUITION	STRECKER BRET	TUITION REIMBURSEMENT 2023	500.00	
100-110-52700	TRAINING AND TUITION	STREET COP TRAINING	NEBRASKA CASE LAW	597.00	
100-110-52710	EMPLOYEE RECRUITMENT/RETENTION	STANARD & ASSOCIATES INC.	LAW ENFORCEMENT OFFICER SELECTION TEST	143.00	
100-110-52800	UNIFORMS	GALLS LLC	BATON, KEY HOLDER, BELT, HANDCUFF CASE,	645.17	
100-110-52810	UNIFORMS-QUARTERMASTER	911 CUSTOM LLC	BLACKINGTON FLEX BADGE #38 - ROMSHEK QM	461.00	
100-110-52810	UNIFORMS-QUARTERMASTER	GUNSLINGERS LLC	SPRINGFIELD GARISON 1911 - WANGLER QM	990.00	
100-110-53200	PROFESSIONAL SERVICES	OCCUPATIONAL HEALTH SERV	COLLECTION & TESTING	67.00	
100-110-53200	PROFESSIONAL SERVICES	PSYCHOLOGICAL RESOURCES	PSYCHOLOGICAL EVALUATION - FRENCH & CLC	300.00	
100-110-53200	PROFESSIONAL SERVICES	SEALOCK GREG	PRE-EMPLOYMENT POLYGRAPH - J FRENCH	125.00	
100-110-54310	BUILDING MAINTENANCE	MENARDS	30" WIRE EASEL, PADLOCK	18.99	
100-110-54310	BUILDING MAINTENANCE	NEBRASKA FIRE SPRINKLER CC	ANNUAL FIRE SPRINKLER INSPECTION	440.00	
100-110-54320	EQUIPMENT MAINTENANCE	EAKES OFFICE SOLUTIONS	COPIER CONTRACT	310.73	
100-110-54320	EQUIPMENT MAINTENANCE	NPAS INC	REPAIR	663.35	
100-110-54380	MAINTENANCE AGREEMENTS	DAS STATE ACCOUNTING	MONTHLY NETWORK CHARGES	256.00	
100-110-56010	SUPPLIES	CAPITAL ONE - WALMART	FOAM CUPS, BATTERIES, TAPE MEASURE, TRF	196.64	
100-110-56010	SUPPLIES	HADLEY-BRAITHWAIT COMPANY	2 CASES COFFEE FILTERS	47.25	
100-110-56010	SUPPLIES	MENARDS	30" WIRE EASEL, PADLOCK	4.99	
100-110-56020	OFFICE SUPPLIES	CAPITAL ONE - WALMART	ONN 16GB, 32G USB 3PK	49.28	
100-110-56030	CLEANING SUPPLIES/SERVICE	SERVICEMASTER BY SHEVLIN	JANITORIAL SERVICES	2,413.00	
100-110-56040	POSTAGE AND FREIGHT	PETTY CASH	PETTY CASH	9.55	
100-110-56050	FUEL	SAPP BROS COLUMBUS INC	FUEL	10,185.03	
100-110-56150	D.A.R.E. EXPENSE	GODFATHER'S PIZZA	PIZZA	192.00	
100-110-56230	WATER AND SEWER	CITY OF COLUMBUS	WATER & SEWER	138.99	
100-110-56240	TELEPHONE	GREAT PLAINS COMMUNICATION	PHONE/INTERNET CHARGES 05/16 - 06/15	412.76	
100-110-57510-23004	CAPITAL-EQUIPMENT	SEILER INSTRUMENT & MFG CC	GROUND CONTROL POINT 5 PACK	399.99	
Total For Dept 110 POLICE				20,216.14	
Dept 120 FIRE					
100-120-54310	BUILDING MAINTENANCE	BOMGAARS	LOCKING CONNECTOR	14.99	
100-120-54310	BUILDING MAINTENANCE	NEBRASKA FIRE SPRINKLER CC	ANNUAL FIRE SPRINKLER INSPECTION	147.50	
100-120-54310	BUILDING MAINTENANCE	OBRIST & CO INC	REPLACE ORING IN TOILET	76.50	
100-120-54310	BUILDING MAINTENANCE	PRESTOX	PEST CONTROL - 4630 HOWARD BLVD	28.81	
100-120-56010	SUPPLIES	MENARDS	4-LVL RACK, 16QT CRATE, 40 GALLON TOTE	950.23	
100-120-56020	OFFICE SUPPLIES	CAPITAL BUSINESS SYSTEMS	COPIER CONTRACT	29.33	
100-120-56020	OFFICE SUPPLIES	HOMETOWN LEASING	COPIER LEASE PAYMENT	87.50	
100-120-56030	CLEANING SUPPLIES/SERVICE	HADLEY-BRAITHWAIT COMPANY	CASE MULTIFOLD TOWELS	22.98	
100-120-56030	CLEANING SUPPLIES/SERVICE	JACKSON SERVICES INC	MATS, MOPS, POLISH TOWEL, WINDSHIELD WI	66.83	
100-120-56230	WATER AND SEWER	CITY OF COLUMBUS	WATER & SEWER	200.96	
100-120-56240	TELEPHONE	GREAT PLAINS COMMUNICATION	PHONE/INTERNET CHARGES 05/16 - 06/15	120.46	

UNJOURNALIZED
 BOTH OPEN AND PAID

GL Number	Invoice Line Desc	Vendor	Invoice Description	Amount	Check #
Fund 100 GENERAL FUND					
Dept 120 FIRE					
100-120-57200-20021	CAPITAL-LAND & BUILDINGS	B-D CONSTRUCTION INC	COLUMBUS FIRE STATION #2	128,685.39	
100-120-57200-20021	CAPITAL-LAND & BUILDINGS	BEST BUY BUSINESS ADVANTAGE	4 - SAMSUNG 43" SMART TVS	969.96	
100-120-57200-20021	CAPITAL-LAND & BUILDINGS	CLEANWASH LAUNDRY SYSTEMS	BALANCE DUE	56.00	
100-120-57200-20021	CAPITAL-LAND & BUILDINGS	MENARDS	DRYER CORD	51.98	
100-120-57520-23006	CAPITAL-VEHICLES	AUTOGRAPHIX INC	REFLECTIVE GRAPHICS	1,675.00	
100-120-57520-23006	CAPITAL-VEHICLES	DANKO EMERGENCY EQUIPMENT	HORIZONTAL FOR 6.75 TO 7.25, RESTRAINT	355.50	
100-120-57520-23006	CAPITAL-VEHICLES	JONES AUTOMOTIVE	LIGH & SIREN PACKAGE- 2022 CHEVY VIN #2	25,994.41	
Total For Dept 120 FIRE				159,534.33	
Dept 121 RESCUE					
100-121-54310	BUILDING MAINTENANCE	BOMGAARS	LOCKING CONNECTOR	15.00	
100-121-54310	BUILDING MAINTENANCE	NEBRASKA FIRE SPRINKLER CO	ANNUAL FIRE SPRINKLER INSPECTION	147.50	
100-121-54310	BUILDING MAINTENANCE	OBRIST & CO INC	REPLACE ORING IN TOILET	76.50	
100-121-54310	BUILDING MAINTENANCE	PRESTOX	PEST CONTROL - 4630 HOWARD BLVD	28.82	
100-121-54320	EQUIPMENT MAINTENANCE	ELECTRONIC ENGINEERING	ANTENNA ROD, COUPLING NUT	578.10	
100-121-54330	VEHICLE MAINTENANCE	O'REILLY AUTOMOTIVE INC	BATTERY	140.38	
100-121-56010	SUPPLIES	BOUND TREE MEDICAL LLC	LANCETS	122.50	
100-121-56010	SUPPLIES	COLUMBUS COMMUNITY HOSPITAL	MEDICAL SUPPLIES	1,411.45	
100-121-56020	OFFICE SUPPLIES	HOMETOWN LEASING	COPIER LEASE PAYMENT	87.50	
100-121-56030	CLEANING SUPPLIES/SERVICE	HADLEY-BRAITHWAIT COMPANY	CASE MULTIFOLD TOWELS	22.97	
100-121-56030	CLEANING SUPPLIES/SERVICE	JACKSON SERVICES INC	MATS, MOPS, POLISH TOWEL, WINDSHIELD WI	66.83	
100-121-56030	CLEANING SUPPLIES/SERVICE	STERICYCLE INC	MEDICAL WASTE SERVICES	1,061.33	
100-121-56230	WATER AND SEWER	CITY OF COLUMBUS	WATER & SEWER	200.96	
100-121-56240	TELEPHONE	GREAT PLAINS COMMUNICATION	PHONE/INTERNET CHARGES 05/16 - 06/15	120.46	
Total For Dept 121 RESCUE				4,080.30	
Dept 125 VOLUNTEER FIRE DEPARTMENT					
100-125-52700	TRAINING AND TUITION	BOARDERS INN & SUITES	LODGING FIRE SCHOOL - FRENCH, NELSON, I	1,499.40	
100-125-56010	SUPPLIES	BOUND TREE MEDICAL LLC	GLUTOSE 15GM, ELECTRODES MULTIPLE FUNC	705.04	
100-125-56010	SUPPLIES	MATHESON-LINWELD	MEDICAL OXYGEN	96.19	
Total For Dept 125 VOLUNTEER FIRE DEPARTMENT				2,300.63	
Dept 130 LIBRARY					
100-130-52710	EMPLOYEE RECRUITMENT/RETENTION	COLUMBUS CUSTOM EMBROIDERY	POLOS - DOUG & MICHELLE MOORE	53.00	
100-130-52710	EMPLOYEE RECRUITMENT/RETENTION	EAKES OFFICE SOLUTIONS	BADGES	19.94	
100-130-52710	EMPLOYEE RECRUITMENT/RETENTION	OCCUPATIONAL HEALTH SERV	COLLECTION & TESTING	230.00	
100-130-53400-PCLAB	COMPUTER SUPPORT/MAINT	EAKES OFFICE SOLUTIONS	TONER	171.99	
100-130-55400	ADVERTISING AND PROMOTION	BEST VERSION MEDIA, LLC	AD MANAGEMENT FEE	152.00	
100-130-56030	CLEANING SUPPLIES/SERVICE	SERVICEMASTER BY SHEVLIN	JANITORIAL SERVICES	2,095.00	
100-130-56040-ILILO	POSTAGE AND FREIGHT	CASEY'S MAIL SERVICE LLC	LIBRARY/MEDIA MAIL	522.95	
100-130-56230	WATER AND SEWER	CITY OF COLUMBUS	WATER & SEWER	95.14	
100-130-56240	TELEPHONE	FRONTIER	TELEPHONE NEW BUILDING - 5/13/23 TO 6/1	135.87	
100-130-56240	TELEPHONE	GREAT PLAINS COMMUNICATION	PHONE/INTERNET CHARGES 05/16 - 06/15	102.20	
100-130-56250	REFUSE	U & I SANITATION	APRIL SERVICE	100.00	
100-130-56400-CHSRP	PROGRAMS	QUINN JEFF	SUMMER READING PROGRAM MAGIC SHOW	300.00	
100-130-56400-CHSRP	PROGRAMS	STRING BEANS LTD	SUMMER READING PROGRAM	975.00	
100-130-56400-CHSRP	PROGRAMS	TOBY KID KLAUENBERG	PRO-READING COMEDY SHOW	545.00	
100-130-56400-YASCH	PROGRAMS	GODFATHER'S PIZZA	PIZZA	116.18	
100-130-56410-ADULT	BOOKS AND PUBLICATIONS	CENTER POINT LARGE PRINT	MATERIALS	21.75	
100-130-56410-ADULT	BOOKS AND PUBLICATIONS	GALE	MATERIALS	218.69	
100-130-56410-ADULT	BOOKS AND PUBLICATIONS	GREY HOUSE PUBLISHING INC	WEISS RATINGS CONSUMER BOX SET	462.05	
100-130-56410-ADULT	BOOKS AND PUBLICATIONS	INGRAM LIBRARY SERVICES, I	MATERIALS	299.64	
100-130-56410-ADULT	BOOKS AND PUBLICATIONS	MIDWEST TAPE LLC	MATERIALS	144.68	

UNJOURNALIZED
 BOTH OPEN AND PAID

GL Number	Invoice Line Desc	Vendor	Invoice Description	Amount	Check #
Fund 100 GENERAL FUND					
Dept 130 LIBRARY					
100-130-56410-CHILD	BOOKS AND PUBLICATIONS	INGRAM LIBRARY SERVICES, I	MATERIALS	11.82	
100-130-56410-YOUNG	BOOKS AND PUBLICATIONS	INGRAM LIBRARY SERVICES, I	MATERIALS	182.14	
Total For Dept 130 LIBRARY				6,955.04	
Dept 140 CEMETERY					
100-140-44510	CEMETERY-LOTS	BARNES ELEANOR	CEMETARY LOT - SECTION O LOT 182 SPACE	200.00	
100-140-52710	EMPLOYEE RECRUITMENT/RETENTION	OCCUPATIONAL HEALTH SERV	COLLECTION & TESTING	67.00	
100-140-56230	WATER AND SEWER	CITY OF COLUMBUS	WATER & SEWER	26.46	
100-140-56240	TELEPHONE	GREAT PLAINS COMMUNICATION	PHONE/INTERNET CHARGES 05/16 - 06/15	7.30	
Total For Dept 140 CEMETERY				300.76	
Dept 145 COMMUNITY DEVELOPMENT					
100-145-52700	TRAINING AND TUITION	CURTIS DANIEL	FEE FOR KEN STEINER TRAINING VIDEO	69.00	
100-145-52710	EMPLOYEE RECRUITMENT/RETENTION	OCCUPATIONAL HEALTH SERV	COLLECTION & TESTING	230.00	
100-145-53400	COMPUTER SUPPORT/MAINT	LABORDE, ADAM	GIS SUPPORT SERVICES MARCH/APRIL 2023	130.00	
100-145-54320	EQUIPMENT MAINTENANCE	ACE HARDWARE & GARDEN CNT	KEY SCHLAGE	2.79	
100-145-54320	EQUIPMENT MAINTENANCE	MENARDS	GAS CANS, BRIGGS 2 STROKE, ACTIVARMR GE	60.53	
100-145-54320	EQUIPMENT MAINTENANCE	REARDON LAWN & GARDEN INC	MOWER, TRIMMER, HAND HELD BLOWER	1,967.96	
100-145-56020	OFFICE SUPPLIES	EAKES OFFICE SOLUTIONS	COMP BOOKS, JNR PAD	162.13	
100-145-56240	TELEPHONE	GREAT PLAINS COMMUNICATION	PHONE/INTERNET CHARGES 05/16 - 06/15	36.50	
Total For Dept 145 COMMUNITY DEVELOPMENT				2,658.91	
Dept 150 PARKS					
100-150-52710	EMPLOYEE RECRUITMENT/RETENTION	COLUMBUS CUSTOM EMBROIDERY	POLOS - DOUG & MICHELLE MOORE	66.00	
100-150-52710	EMPLOYEE RECRUITMENT/RETENTION	OCCUPATIONAL HEALTH SERV	COLLECTION & TESTING	201.00	
100-150-52800	UNIFORMS	JACKSON SERVICES INC	UNIFORMS	77.36	
100-150-53400	COMPUTER SUPPORT/MAINT	LABORDE, ADAM	GIS SUPPORT SERVICES MARCH/APRIL 2023	130.00	
100-150-54310	BUILDING MAINTENANCE	ACE HARDWARE & GARDEN CNT	KEY MASTER	110.77	
100-150-54310	BUILDING MAINTENANCE	BOMGAARS	PULLEY, PAIRED DISCONNECT, BOLTS	14.50	
100-150-54320	EQUIPMENT MAINTENANCE	ACE HARDWARE & GARDEN CNT	WIRE & WIRING SUPPLIES, ANTI-SHORT BUSH	33.61	
100-150-54320	EQUIPMENT MAINTENANCE	ALTEC INDUSTRIES INC	PM INSPECTION, DIELECTRIC TEST - VIN #6	1,206.00	
100-150-54320	EQUIPMENT MAINTENANCE	ARNOLD MOTOR SUPPLY	O-RING, FLANGE O-RING	309.69	
100-150-54320	EQUIPMENT MAINTENANCE	BOMGAARS	SOCKET 12PT, JUMBO WRENCH	62.98	
100-150-54320	EQUIPMENT MAINTENANCE	MATHESON-LINWELD	CARBON DIOXIDE 10LB AL	60.00	
100-150-54320	EQUIPMENT MAINTENANCE	MENARDS	MF-SKT 3/4 DR 12PT	21.98	
100-150-54320	EQUIPMENT MAINTENANCE	MUELLER SPRINKLERS	SWITCH-PTO	51.99	
100-150-54320	EQUIPMENT MAINTENANCE	REARDON LAWN & GARDEN INC	OPTI-2 1.8OZ	23.94	
100-150-54320	EQUIPMENT MAINTENANCE	TIRE OUTLET INC	TIRE	236.00	
100-150-54320	EQUIPMENT MAINTENANCE	TURFWERKS	SVC-WLDMT, BRG-BALL, BEARING, WASHER, F	2,447.74	
100-150-54490	IRRIGATION MAINTENANCE	ACE HARDWARE & GARDEN CNT	RISER, CUT-OFF RISER, BUSHING	19.08	
100-150-54520	EQUIPMENT RENTAL/PURCHASE	BSN SPORTS LLC	HOMERUN FENCE	4,431.01	
100-150-56010	SUPPLIES	ACE HARDWARE & GARDEN CNT	AJAX CLEANER	73.63	
100-150-56010	SUPPLIES	MID-AMERICAN RESEARCH	BOWL CLEANER	150.00	
100-150-56010	SUPPLIES	SHEVLIN SUPPLY	TOILET TISSUE	366.20	
100-150-56080	PLANTS SOD SEED FLOWERS	EARL MAY SEED & NURSERY L.	PLANTS	202.81	
100-150-56080	PLANTS SOD SEED FLOWERS	WILKE LANDSCAPE CENTER	PLANTS	399.45	
100-150-56230	WATER AND SEWER	CITY OF COLUMBUS	WATER & SEWER	3,747.13	
100-150-56240	TELEPHONE	GREAT PLAINS COMMUNICATION	PHONE/INTERNET CHARGES 05/16 - 06/15	29.20	
100-150-56300	FOOD COSTS	CAPITAL ONE - WALMART	HOTDOG BUNS, POWERADE, HOTDOGS, WATER	488.60	
100-150-56300	FOOD COSTS	SUPER SAVER	POP & POWERADE FOR CONCESSIONS	112.12	
100-150-56400	PROGRAMS	ALBERS AUSTIN	UMP: MEN'S LEAGUE 5/23	60.00	
100-150-56400	PROGRAMS	BARRELHOUSE	2 HOUR SHOW - SUMMER CONCERT SERIES	800.00	
100-150-56400	PROGRAMS	BORCHERS DEVON	UMP: MIXED LEAGUE 5/17, 5/24	180.00	

UNJOURNALIZED
 BOTH OPEN AND PAID

GL Number	Invoice Line Desc	Vendor	Invoice Description	Amount	Check #
Fund 100 GENERAL FUND					
Dept 150 PARKS					
100-150-56400	PROGRAMS	CLINE RANDY	UMP: MEN'S LEAGUE 5/16, 5/23; MIXED LEF	350.00	
100-150-56400	PROGRAMS	CLINE TYLER	UMP: MEN'S LEAGUE 5/16, 5/23; MIXED LEF	300.00	
100-150-56400	PROGRAMS	COLUMBUS SCREEN PRINTING	SHIRTS	568.00	
100-150-56400	PROGRAMS	DOMINGUEZ MARK	UMP: MEN'S LEAGUE 5/16; MIXED LEAGUE 5/	240.00	
100-150-56400	PROGRAMS	GREAT PLAINS BUILDING SUPPL	ATHLETIC FIELD MARKER	608.16	
100-150-56400	PROGRAMS	GUTIERREZ JUAN	UMP: MEN'S LEAGUE 5/23; MIXED LEAGUE 5/	150.00	
100-150-56400	PROGRAMS	LOPEZ ANDY G	SATURDAY CONCERT SERIES: ANDY WILLIAM &	3,000.00	
100-150-56400	PROGRAMS	VOICE HOUSE	LAWN CHAIRS ON THE SQUARE PERFORMANCE	2,100.00	
100-150-57300-23013	CAPITAL-NEW CONSTRUCTION	SAND CREEK CONSTRUCTION CO	GERRARD PARK TENNIS & PICKLEBALL COURT	11,750.00	
Total For Dept 150 PARKS				35,178.95	
Dept 151 PAWNEE PLUNGE WATER PARK					
100-151-44717	PASSES	BAUER MICHELLE	REFUND MEMBERSHIP-S/B HOUSEHOLD MEMBERS	200.00	
100-151-52710	EMPLOYEE RECRUITMENT/RETENTION	OCCUPATIONAL HEALTH SERV	COLLECTION & TESTING	2,747.00	
100-151-52800	UNIFORMS	COLUMBUS SCREEN PRINTING	T-SHIRTS, HOODIES	2,500.00	
100-151-52800	UNIFORMS	THE LIFEGUARD STORE	UNIFORMS	6,900.00	
100-151-53200	PROFESSIONAL SERVICES	NEBRASKA STATE FIRE MARSH	ANNUAL BOILER CERTIFICATE PAWNEE PLUNGE	72.00	
100-151-54310	BUILDING MAINTENANCE	ACE HARDWARE & GARDEN CNT	NUTS, BOLTS, SCREWS	239.43	
100-151-54310	BUILDING MAINTENANCE	COMMONWEALTH ELECTRIC COM	3 PHASE FLAGS NOT WORKING - PAWNEE PLUN	189.00	
100-151-54310	BUILDING MAINTENANCE	KELLY SUPPLY COMPANY	FLANGE SPIGOT	187.99	
100-151-54310	BUILDING MAINTENANCE	NORTHWEST ELECTRIC LLC	BLEW OUT/FREED UP SWITCH	75.00	
100-151-54310	BUILDING MAINTENANCE	SCHIEFFER SIGNS INC	SIGNS, WIRE STANDS	828.00	
100-151-54320	EQUIPMENT MAINTENANCE	ACE HARDWARE & GARDEN CNT	2 CYCLE OIL	21.54	
100-151-54320	EQUIPMENT MAINTENANCE	KELLY SUPPLY COMPANY	PVC ELL SOC, SLIP FLANGE, VACUUM BREAK	564.18	
100-151-54320	EQUIPMENT MAINTENANCE	NORTHWEST ELECTRIC LLC	REPAIR MOTOR - PP PUMP LAP	5,940.12	
100-151-55900	MISCELLANEOUS	SCHIEFFER SIGNS INC	SIGNS, WIRE STANDS	328.50	
100-151-56010	SUPPLIES	ACE HARDWARE & GARDEN CNT	KEY KWIKSET, KEY MASTER	41.65	
100-151-56010	SUPPLIES	SHEVLIN SUPPLY	CENTER PULL TOWEL, BATH TISSUE, NITRILE	838.14	
100-151-56020	OFFICE SUPPLIES	EAKES OFFICE SOLUTIONS	INK CARTRIDGES	676.72	
100-151-56030	CLEANING SUPPLIES/SERVICE	JACKSON SERVICES INC	TEA TOWELS, BAR MOPS	51.63	
100-151-56090	SMALL TOOLS	ACE HARDWARE & GARDEN CNT	PUSH THREAD ADAPTER	44.46	
100-151-56230	WATER AND SEWER	CITY OF COLUMBUS	WATER & SEWER	548.29	
100-151-56240	TELEPHONE	GREAT PLAINS COMMUNICATION	PHONE/INTERNET CHARGES 05/16 - 06/15	14.60	
100-151-56300	FOOD COSTS	MAHASKA	COLD BREW	230.00	
100-151-56300	FOOD COSTS	MW MINI MELTS LLC	MINI MELTS	2,726.00	
100-151-56300	FOOD COSTS	SYSCO LINCOLN	CONCESSIONS	10,446.33	
100-151-57510-21049	CAPITAL-EQUIPMENT	SAND CREEK CONSTRUCTION CO	DESIGN BUILD FAMILY WATER SLIDE	2,500.00	
Total For Dept 151 PAWNEE PLUNGE WATER PARK				38,910.58	
Dept 152 AQUATIC CENTER POOL					
100-152-52710	EMPLOYEE RECRUITMENT/RETENTION	OCCUPATIONAL HEALTH SERV	COLLECTION & TESTING	67.00	
100-152-52800	UNIFORMS	COLUMBUS SCREEN PRINTING	T-SHIRTS, HOODIES	326.00	
100-152-52800	UNIFORMS	THE LIFEGUARD STORE	UNIFORMS	353.50	
100-152-54310	BUILDING MAINTENANCE	ARNOLD MOTOR SUPPLY	VULCO STRAIGHT COOLANT HOSE	154.08	
100-152-56010	SUPPLIES	CAPITAL ONE - WALMART	SUPPLIES FOR AQUATICS CORAL CLASS	50.56	
100-152-56020	OFFICE SUPPLIES	EAKES OFFICE SOLUTIONS	INK CARTRIDGES	327.01	
100-152-56230	WATER AND SEWER	CITY OF COLUMBUS	WATER & SEWER	279.97	
100-152-56240	TELEPHONE	GREAT PLAINS COMMUNICATION	PHONE/INTERNET CHARGES 05/16 - 06/15	14.60	
Total For Dept 152 AQUATIC CENTER POOL				1,572.72	
Dept 155 VAN BERG GOLF COURSE					
100-155-52710	EMPLOYEE RECRUITMENT/RETENTION	OCCUPATIONAL HEALTH SERV	COLLECTION & TESTING	230.00	
100-155-54320	EQUIPMENT MAINTENANCE	ARNOLD MOTOR SUPPLY	O-RING, WIRE BRAID HOSE	72.11	

UNJOURNALIZED
BOTH OPEN AND PAID

GL Number	Invoice Line Desc	Vendor	Invoice Description	Amount	Check #
Fund 100 GENERAL FUND					
Dept 155 VAN BERG GOLF COURSE					
100-155-54320	EQUIPMENT MAINTENANCE	INDUSTRIAL CONTROL SYSTEMS	EXPRESS DUAL 3000 BLADE SHARPENER - REI	1,382.41	
100-155-54320	EQUIPMENT MAINTENANCE	MENARDS	BATTERY TRANSFER PUMP	12.99	
100-155-54320	EQUIPMENT MAINTENANCE	NAPA AUTO PARTS OF COLUMBUS	BATTERY	231.27	
100-155-54320	EQUIPMENT MAINTENANCE	REARDON LAWN & GARDEN INC	SWITCH, CABLE ASSY	31.98	
100-155-54320	EQUIPMENT MAINTENANCE	TIRE OUTLET INC	MOUNT & DISPOSAL	10.00	
100-155-54350	GOLF CART/COURSE MAINT	NEBRASKA GOLF & TURF INC	GASKETS, FUEL TANK CAP, FUEL PUMP KIT, C	222.09	
100-155-56010	SUPPLIES	ACE HARDWARE & GARDEN CNT	RED MULCH	65.92	
100-155-56010	SUPPLIES	AG SPRAY EQUIPMENT	BALL VALVE, HOSE BARB, POLY PIPE NIPPLE	71.55	
100-155-56070	FERTILIZER	D & K PRODUCTS	IGNITION 18-3-6, IGNITION IRON PLUS	1,007.50	
100-155-56230	WATER AND SEWER	CITY OF COLUMBUS	WATER & SEWER	50.55	
100-155-56240	TELEPHONE	GREAT PLAINS COMMUNICATION	PHONE/INTERNET CHARGES 05/16 - 06/15	21.90	
Total For Dept 155 VAN BERG GOLF COURSE				3,410.27	
Dept 156 QUAIL RUN GOLF COURSE					
100-156-54320	EQUIPMENT MAINTENANCE	NAPA AUTO PARTS OF COLUMBUS	BATTERY	137.82	
100-156-54350	GOLF CART/COURSE MAINT	NEBRASKA GOLF & TURF INC	SPEED SENSOR - SERVICE PACKAGE	467.19	
100-156-54490	IRRIGATION MAINTENANCE	KELLY SUPPLY COMPANY	PVC-40 COMP COUP	65.70	
100-156-54490	IRRIGATION MAINTENANCE	MIDWEST TURF & IRRIGATION	ADJUSTABLE FLAG KEY, UTILITY TOOL, VLA	652.80	
100-156-54510	BUILDING RENTAL/LEASE	BRUNKEN JED	ANNUAL LEASE FOR QR SIGN PLACEMENT	1.00	
100-156-54520	EQUIPMENT RENTAL/PURCHASE	MR GOLF CAR INC	RENTAL/TOURNAMENT CARS ON 5/20/23	1,920.00	
100-156-56010	SUPPLIES	ACE HARDWARE & GARDEN CNT	GARDEN SPADE	12.97	
100-156-56010	SUPPLIES	AG SPRAY EQUIPMENT	HOSE BARB, TEEJET, AIR INDUCTION	97.89	
100-156-56010	SUPPLIES	JACKSON SERVICES INC	UNIFORMS	107.71	
100-156-56010	SUPPLIES	PREFERRED PIPELINE LLC	SAND	796.80	
100-156-56010	SUPPLIES	TRUCK CENTER COMPANIES	1 GAL LIQUITUBE W/PUMP	62.15	
100-156-56050	FUEL	SAPP BROS COLUMBUS INC	FUEL	2,898.14	
100-156-56060	CHEMICALS	ZIMCO SUPPLY CO	ARMAMENT, ARMOR TECH, IPRODIONE, STRES	4,859.50	
100-156-56070	FERTILIZER	ZIMCO SUPPLY CO	STN+ARMAMENT 50# BAG	4,560.00	
100-156-56110	PRO-SHOP SUPPLIES	CULLIGAN OF COLUMBUS	SALT PELLET DELIVERED 50#	52.00	
100-156-56110	PRO-SHOP SUPPLIES	HADLEY-BRAITHWAIT COMPANY	TOILET PAPER, CENTER PULL TOWELS	117.90	
100-156-56110	PRO-SHOP SUPPLIES	THE GOLF SHOP	55-60 GALLON TRASH BAGS ON ROLLS	421.52	
100-156-56230	WATER AND SEWER	CITY OF COLUMBUS	WATER & SEWER	310.32	
100-156-56240	TELEPHONE	GREAT PLAINS COMMUNICATION	PHONE/INTERNET CHARGES 05/16 - 06/15	58.40	
100-156-56650	MEMBERSHIP DUES	CLUB PROPHET SYSTEMS	MONTHLY ADDITIONAL USER	60.00	
Total For Dept 156 QUAIL RUN GOLF COURSE				17,659.81	
Total For Fund 100 GENERAL FUND				335,318.85	
Fund 200 STREETS/ENGINEERING					
Dept 200 STREETS					
200-200-52700	TRAINING AND TUITION	CAMBRIA HOTEL OMAHA DOWNTOWN	COMPLETE BORCHERS	859.30	
200-200-52710	EMPLOYEE RECRUITMENT/RETENTION	OCCUPATIONAL HEALTH SERV	COLLECTION & TESTING	67.00	
200-200-52800	UNIFORMS	JACKSON SERVICES INC	MATS, SHOP TOWELS, UNIFORMS	679.39	
200-200-53200	PROFESSIONAL SERVICES	MOMS & MOPS	CLEANING CENTRAL MAINTENANCE	133.34	
200-200-53400	COMPUTER SUPPORT/MAINT	EAKES OFFICE SOLUTIONS	COPIER CONTRACT	135.02	
200-200-53400	COMPUTER SUPPORT/MAINT	LABORDE, ADAM	GIS SUPPORT SERVICES MARCH/APRIL 2023	325.00	
200-200-54310	BUILDING MAINTENANCE	ELECTRICAL ENGINEERING &	BAYE3-PS240-FCCT-U 240/200/180W120-277V	185.00	
200-200-54320	EQUIPMENT MAINTENANCE	AG SPRAY EQUIPMENT	STRAINER HEAD, REDUCER BEARRING & NIPPI	28.20	
200-200-54320	EQUIPMENT MAINTENANCE	ALTEC INDUSTRIES INC	PM INSPECTION & DIELECTRIC TESTS VIN #	1,490.23	
200-200-54320	EQUIPMENT MAINTENANCE	BOMGAARS	ELBOW, HOSE BARB	6.48	
200-200-54320	EQUIPMENT MAINTENANCE	MACQUEEN EQUIPMENT	REPAIR SWEEPER	7,082.95	
200-200-54320	EQUIPMENT MAINTENANCE	MICHAEL TODD & COMPANY INC	ELGIN EAGLE/BROOM BEAR TUBE 60"	708.07	
200-200-54320	EQUIPMENT MAINTENANCE	MID-IOWA SOLID WASTE	4 SEGMENT GUTTER BROOM	524.54	

UNJOURNALIZED
BOTH OPEN AND PAID

GL Number	Invoice Line Desc	Vendor	Invoice Description	Amount	Check #
Fund 200 STREETS/ENGINEERING					
Dept 200 STREETS					
200-200-54320	EQUIPMENT MAINTENANCE	REARDON LAWN & GARDEN INC	AIR FILTER, FILTER	47.96	
200-200-54320	EQUIPMENT MAINTENANCE	RIVER VALLEY TIRE SERVICE	TRAILER TIRE REPAIR	15.00	
200-200-54320	EQUIPMENT MAINTENANCE	SHERWIN-WILLIAMS CO	REPAIR KIT	153.00	
200-200-54320	EQUIPMENT MAINTENANCE	TIRE OUTLET INC	4 -TIRES, 4 - TUBES	744.00	
200-200-54330	VEHICLE MAINTENANCE	O'REILLY AUTOMOTIVE INC	TOWING KIT, SECURITY KIT, PIN & CLIP	106.96	
200-200-54450	STREET MAINTENANCE	GEHRING CONSTRUCTION &	3413 34TH STREET	2,306.19	
200-200-54450	STREET MAINTENANCE	GERHOLD CONCRETE COMPANY	4114 SUNSET DRIVE	798.33	
200-200-56010	SUPPLIES	ACE HARDWARE & GARDEN CNT	ELASTOSTART ROPE	182.43	
200-200-56010	SUPPLIES	BOMGAARS	CHOP SAW WHEEL	76.88	
200-200-56010	SUPPLIES	EAKES OFFICE SOLUTIONS	LAMINATE	85.91	
200-200-56010	SUPPLIES	HADLEY-BRAITHWAIT COMPANY	MULTIFOLD TOWELS, TOILET PAPER	86.93	
200-200-56010	SUPPLIES	MENARDS	BLUE TOWELS, IRISH SPRING, MOTH BALLS	141.79	
200-200-56010	SUPPLIES	PETTY CASH	REIMBURSE FOR TRASH BAGS	9.66	
200-200-56010	SUPPLIES	SHERWIN-WILLIAMS CO	QP EASY OUT FLT	17.99	
200-200-56050	FUEL	SAPP BROS COLUMBUS INC	FUEL	11,051.00	
200-200-56090	SMALL TOOLS	BOMGAARS	HAMMER, PINS	19.99	
200-200-56120	TRAFFIC SIGNS	MENARDS	ELECTAPE, PVC COUPLER, HEAT SHRINK TUBE	119.43	
200-200-56120	TRAFFIC SIGNS	NEWMAN SIGNS INC.	SIGNS	1,511.81	
200-200-56190	PERSONAL PROTECTIVE SUPP	BOMGAARS	UNLINED GLOVES, GRAB & GO SPRAYER	59.94	
200-200-56190	PERSONAL PROTECTIVE SUPP	MOTION INDUSTRIES INC	CORDED FOAM EARPLUGS	52.21	
200-200-56230	WATER AND SEWER	CITY OF COLUMBUS	WATER & SEWER	125.54	
200-200-56240	TELEPHONE	GREAT PLAINS COMMUNICATION	PHONE/INTERNET CHARGES 05/16 - 06/15	29.20	
200-200-57200-23025	CAPITAL-LAND & BUILDINGS	GEHRING CONSTRUCTION &	SID #189 - 48TH AVE FROM 23RD ST TO S C	431,078.92	
200-200-57200-23025	CAPITAL-LAND & BUILDINGS	MID-STATE ENGINEERING & TR	COLUMBUS PAVING IMPROVEMENTS SID 189	572.50	
200-200-57300-20070	CAPITAL-NEW CONSTRUCTION	SCHEMMER ASSOCIATES INC.	23RD ST WATER & SEWER CONSTRUCTION INSE	14,108.14	
200-200-57300-20071	CAPITAL-NEW CONSTRUCTION	GEHRING CONSTRUCTION &	SID #189 - 48TH AVE FROM 23RD ST TO S C	382,277.54	
200-200-57300-20076	CAPITAL-NEW CONSTRUCTION	GEHRING CONSTRUCTION &	SID #184 - 23RD STREET FROM EAST OF 48I	92,234.00	
200-200-57510-23027	CAPITAL-EQUIPMENT	MID-IOWA SOLID WASTE	STREET SWEEPER	345,100.00	
Total For Dept 200 STREETS				1,295,337.77	
Dept 202 MECHANICS SHOP					
200-202-52700	TRAINING AND TUITION	GODFATHER'S PIZZA	PIZZA	29.99	
200-202-52800	UNIFORMS	JACKSON SERVICES INC	MATS, SHOP TOWELS, UNIFORMS	99.28	
200-202-56010	SUPPLIES	BOMGAARS	TORCH KIT	137.34	
200-202-56010	SUPPLIES	FASTENAL COMPANY	100 - 12-24X7/8 HWH TEKS4	33.98	
200-202-56010	SUPPLIES	O'REILLY AUTOMOTIVE INC	3.3 OZ ELEC GRS	29.98	
200-202-56130	SUPPLIES FOR RESALE	ADVANCE AUTO PARTS	STARTER	528.36	
200-202-56130	SUPPLIES FOR RESALE	ARNOLD MOTOR SUPPLY	TRLR-CONN, CONNECTOR	425.98	
200-202-56130	SUPPLIES FOR RESALE	INTERSTATE BATTERY SYSTEM	2 - BATTERIES	716.80	
200-202-56130	SUPPLIES FOR RESALE	LAWSON PRODUCTS	GATES 2 BRAID HOSE	523.50	
200-202-56130	SUPPLIES FOR RESALE	NAPA AUTO PARTS OF COLUMBU	BATTERY	327.96	
200-202-56130	SUPPLIES FOR RESALE	O'REILLY AUTOMOTIVE INC	COP COILS	645.18	
Total For Dept 202 MECHANICS SHOP				3,498.35	
Total For Fund 200 STREETS/ENGINEERING				1,298,836.12	
Fund 205 AIRPORT					
Dept 205 AIRPORT					
205-205-54320	EQUIPMENT MAINTENANCE	NAPA AUTO PARTS OF COLUMBU	OIL & AIR FILTER	78.23	
205-205-54480	HANGAR MAINTENANCE	MENARDS	RETURN - FURANCE PIPE, FLEX PIPE CONNEC	65.23	
205-205-55210	CLAIMS AND SETTLEMENTS	JOHNSON, MADDY	REIMBURSE CRACKED WINDSHEILD	64.28	
205-205-55400	ADVERTISING AND PROMOTION	CIVIL AIR PATROL MAGAZINE	ADVERTISING	105.00	
205-205-56010	SUPPLIES	ACE HARDWARE & GARDEN CNT	FUSE PLUG	73.13	

UNJOURNALIZED
 BOTH OPEN AND PAID

GL Number	Invoice Line Desc	Vendor	Invoice Description	Amount	Check #
Fund 205 AIRPORT					
Dept 205 AIRPORT					
205-205-56230	WATER AND SEWER	CITY OF COLUMBUS	WATER & SEWER	25.19	
205-205-56240	TELEPHONE	GREAT PLAINS COMMUNICATION	PHONE/INTERNET CHARGES 05/16 - 06/15	21.90	
205-205-56260	UTILITIES - FSS BUILDING	CITY OF COLUMBUS	WATER & SEWER	54.18	
205-205-56260	UTILITIES - FSS BUILDING	U & I SANITATION	MAY GARBAGE SERVICE	42.50	
205-205-57200-22025	CAPITAL-LAND & BUILDINGS	PLATTE VALLEY PRECAST INC	AIRPORT HANGER	43,159.95	
Total For Dept 205 AIRPORT				43,689.59	
Total For Fund 205 AIRPORT				43,689.59	
Fund 211 1/2 CENT SALES TAX					
Dept 211 1/2 CENT SALES TAX					
211-211-59020	INTEREST AND FISCAL FEES	NEBRASKALAND NATIONAL BAN	LOAN PAYMENT	42,499.99	
Total For Dept 211 1/2 CENT SALES TAX				42,499.99	
Total For Fund 211 1/2 CENT SALES TAX				42,499.99	
Fund 220 COMMUNICATIONS - E911					
Dept 220 E911					
220-220-56010	SUPPLIES	CAPITAL ONE - WALMART	FACE TISSUE	9.98	
220-220-56230	WATER AND SEWER	CITY OF COLUMBUS	WATER & SEWER	54.18	
220-220-56240	TELEPHONE	DAS STATE ACCOUNTING	MONTHLY NETWORK CHARGES	1,215.99	
220-220-56240	TELEPHONE	GREAT PLAINS COMMUNICATION	PHONE/INTERNET CHARGES 05/16 - 06/15	7.30	
220-220-56250	REFUSE	U & I SANITATION	MAY GARBAGE SERVICE	42.50	
Total For Dept 220 E911				1,329.95	
Total For Fund 220 COMMUNICATIONS - E911				1,329.95	
Fund 240 HOUSING REHAB & LOANS					
Dept 243 CDBG REVOLVING REHAB LOAN					
240-243-56780	HOUSING LOANS & ADMIN	NORTHEAST NEBRASKA ECONOMI	CDBG REHAB REUSE APRIL 2023 ADMIN SERVI	93.75	
Total For Dept 243 CDBG REVOLVING REHAB LOAN				93.75	
Dept 244 CDBG DPA LOANS (NENEDD)					
240-244-56780	HOUSING LOANS & ADMIN	NORTHEAST NEBRASKA ECONOMI	DHA TRUST REUSE APRIL 2023 ADMIN SERVIC	169.97	
Total For Dept 244 CDBG DPA LOANS (NENEDD)				169.97	
Dept 245 CDBG GRANTS					
240-245-56780	HOUSING LOANS & ADMIN	10 COUNTY TITLE & ESCROW I	CDBG MATCH	3,234.21	
Total For Dept 245 CDBG GRANTS				3,234.21	
Total For Fund 240 HOUSING REHAB & LOANS				3,497.93	
Fund 500 UTILITY SERVICE					
Dept 000					
500-000-20100	CSX-1	BEHLE NICHOLAS	UB refund for account: 300-58440-04	144.90	
Total For Dept 000				144.90	
Dept 500 WASTEWATER COLLECTION					
500-500-52700	TRAINING AND TUITION	NEBRASKA RURAL WATER ASSOC	MEMBERSHIP RENEWAL	275.00	
500-500-52800	UNIFORMS	JACKSON SERVICES INC	UNIFORMS	366.53	
500-500-53200	PROFESSIONAL SERVICES	MOMS & MOPS	CLEANING CENTRAL MAINTENANCE	133.33	
500-500-53400	COMPUTER SUPPORT/MAINT	EAKES OFFICE SOLUTIONS	COPIER CONTRACT	135.02	
500-500-53400	COMPUTER SUPPORT/MAINT	LABORDE, ADAM	GIS SUPPORT SERVICES MARCH/APRIL 2023	195.00	
500-500-54320	EQUIPMENT MAINTENANCE	ACE HARDWARE & GARDEN CNT	EDGER BLADE	5.49	

UNJOURNALIZED
 BOTH OPEN AND PAID

GL Number	Invoice Line Desc	Vendor	Invoice Description	Amount	Check #
Fund 500 UTILITY SERVICE					
Dept 500 WASTEWATER COLLECTION					
500-500-54320	EQUIPMENT MAINTENANCE	BOMGAARS	HITCHING RING, SNAP SPRINGS	15.05	
500-500-54320	EQUIPMENT MAINTENANCE	ELECTRIC PUMP INC	MULTISMART SCREEN REPAIR	1,141.81	
500-500-54320	EQUIPMENT MAINTENANCE	KELLY SUPPLY COMPANY	ALUMINUM COUPLING	218.56	
500-500-54390	SYSTEM MAINTENANCE	ACE HARDWARE & GARDEN CNT	TAPE	26.98	
500-500-54390	SYSTEM MAINTENANCE	ELECTRIC PUMP INC	SERVICE CALL - NEW POWER SUPPLIES & BAI	1,751.00	
500-500-54390	SYSTEM MAINTENANCE	KELLY SUPPLY COMPANY	DISCHARGE HOSE, ALUMINUM COUPLING, GAS	1,759.21	
500-500-54390	SYSTEM MAINTENANCE	MENARDS	9 - DAWN 750Z	42.48	
500-500-54390	SYSTEM MAINTENANCE	TOO FAST SUPPLY	DIAMOND BLADE	32.92	
500-500-54390	SYSTEM MAINTENANCE	USA BLUE BOOK	PERSONAL LOCKOUT KITS	448.85	
500-500-56010	SUPPLIES	EAKES OFFICE SOLUTIONS	CENTER PULL TOWELS	41.27	
500-500-56010	SUPPLIES	HADLEY-BRAITHWAIT COMPANY	MULTIFOLD TOWELS, TOILET PAPER	86.93	
500-500-56020	OFFICE SUPPLIES	EAKES OFFICE SOLUTIONS	PERFERED PAPER	109.90	
500-500-56030	CLEANING SUPPLIES/SERVICE	JACKSON SERVICES INC	2 SOAP FOAM BAGS	18.00	
500-500-56040	POSTAGE AND FREIGHT	CASEY'S MAIL SERVICE LLC	DAILY POSTAGE, WATER STATEMENTS	2,067.26	
500-500-56190	PERSONAL PROTECTIVE SUPP	BOMGAARS	2 - JACKETS - LINED HI-V	59.99	
500-500-56230	WATER AND SEWER	CITY OF COLUMBUS	WATER & SEWER	20.92	
500-500-56240	TELEPHONE	GREAT PLAINS COMMUNICATION	PHONE/INTERNET CHARGES 05/16 - 06/15	33.46	
500-500-57300-20091	CAPITAL-NEW CONSTRUCTION	HDR ENGINEERING INC	LOST CREEK PARKWAY SEWER PROJECT	10,442.02	
500-500-57300-20091	CAPITAL-NEW CONSTRUCTION	MID-STATE ENGINEERING & TR	LOST CREEK PARKWAY SEWER & WATER MAIN	902.50	
500-500-57300-20093	CAPITAL-NEW CONSTRUCTION	GILMORE & ASSOCIATES INC	SEWER STUDY & LIFT STATION #14 RENOVATI	7,000.00	
500-500-57300-20094	CAPITAL-NEW CONSTRUCTION	JOHNSON SERVICE COMPANY	INSTALL 15" POINT REPAIR LINER	14,000.00	
Total For Dept 500 WASTEWATER COLLECTION				41,329.48	
Dept 501 WASTEWATER TREATMENT FAC					
500-501-52800	UNIFORMS	JACKSON SERVICES INC	UNIFORMS	302.48	
500-501-54320	EQUIPMENT MAINTENANCE	BOMGAARS	ANTIFREEZ	29.98	
500-501-54320	EQUIPMENT MAINTENANCE	KELLY SUPPLY COMPANY	GATES STEM, HYDRAULIC HOSE	58.08	
500-501-54320	EQUIPMENT MAINTENANCE	LAKEVIEW SMALL ENGINE INC	DIPSTICK	40.28	
500-501-54320	EQUIPMENT MAINTENANCE	MENARDS	7 BLADE TRAILER SIDE	9.49	
500-501-54320	EQUIPMENT MAINTENANCE	NAPA AUTO PARTS OF COLUMBU	FUEL FILTER	10.99	
500-501-54320	EQUIPMENT MAINTENANCE	O'REILLY AUTOMOTIVE INC	PINTLE COMBO, PLATE, PIN & CLIP	208.68	
500-501-54320	EQUIPMENT MAINTENANCE	OBRIST & CO INC	INSTALL 50 GALLON GAS WATER HEATER	2,600.00	
500-501-54330	VEHICLE MAINTENANCE	O'REILLY AUTOMOTIVE INC	MINI LAMP	12.58	
500-501-56010	SUPPLIES	ACE HARDWARE & GARDEN CNT	CNTRHOSE, EZ SEED SUN & SHADE	149.56	
500-501-56010	SUPPLIES	HADLEY-BRAITHWAIT COMPANY	MULTIFOLD TOWELS	202.85	
500-501-56030	CLEANING SUPPLIES/SERVICE	JACKSON SERVICES INC	MAT	60.18	
500-501-56060	CHEMICALS	PETE LIEN & SONS INC.	QUICKLIME FINES	14,737.50	
500-501-56100	LABORATORY	CULLIGAN OF COLUMBUS	DI REGENERATION	379.07	
500-501-56100	LABORATORY	PHENOVA INC	WP MICRO QUANTITATIVE	762.14	
500-501-56230	WATER AND SEWER	CITY OF COLUMBUS	WATER & SEWER	3,917.55	
500-501-56240	TELEPHONE	GREAT PLAINS COMMUNICATION	PHONE/INTERNET CHARGES 05/16 - 06/15	36.50	
Total For Dept 501 WASTEWATER TREATMENT FAC				23,517.91	
Total For Fund 500 UTILITY SERVICE				64,992.29	
Fund 520 WATER					
Dept 000					
520-000-20100	WAM-41	BEHLE NICHOLAS	UB refund for account: 300-58440-04	13.18	
Total For Dept 000				13.18	
Dept 520 WATER					
520-520-52700	TRAINING AND TUITION	NEBRASKA RURAL WATER ASSOC	MEMBERSHIP RENEWAL	275.00	
520-520-52710	EMPLOYEE RECRUITMENT/RETENTION	OCCUPATIONAL HEALTH SERV	COLLECTION & TESTING	67.00	

UNJOURNALIZED
 BOTH OPEN AND PAID

GL Number	Invoice Line Desc	Vendor	Invoice Description	Amount	Check #
Fund 520 WATER					
Dept 520 WATER					
520-520-52800	UNIFORMS	JACKSON SERVICES INC	UNIFORMS	255.28	
520-520-53200	PROFESSIONAL SERVICES	MOMS & MOPS	CLEANING CENTRAL MAINTENANCE	133.33	
520-520-53400	COMPUTER SUPPORT/MAINT	EAKES OFFICE SOLUTIONS	COPIER CONTRACT	135.02	
520-520-53400	COMPUTER SUPPORT/MAINT	LABORDE, ADAM	GIS SUPPORT SERVICES MARCH/APRIL 2023	195.00	
520-520-54320	EQUIPMENT MAINTENANCE	ACE HARDWARE & GARDEN CNT	EDGER BLADE	5.50	
520-520-54320	EQUIPMENT MAINTENANCE	BOMGAARS	STRAP	27.03	
520-520-54320	EQUIPMENT MAINTENANCE	KELLY SUPPLY COMPANY	BRASS ADAPTERS	179.58	
520-520-54320	EQUIPMENT MAINTENANCE	MALLOY ELECTRIC	SERVICE ON MOTOR	2,841.18	
520-520-54320	EQUIPMENT MAINTENANCE	TIRE OUTLET INC	TUBE	85.00	
520-520-54320	EQUIPMENT MAINTENANCE	USA BLUE BOOK	MAINTENACNE KIT FOR CL 17	612.56	
520-520-54390	SYSTEM MAINTENANCE	ELECTRICAL ENGINEERING &	UR-I IDC CONN/100 PK	21.35	
520-520-54390	SYSTEM MAINTENANCE	GEHRING CONSTRUCTION &	2270 CIRCLE DRIVE	663.00	
520-520-54390	SYSTEM MAINTENANCE	LOSEKE LAKE STOP LLC	36 - SOD ROLLS	132.84	
520-520-54390	SYSTEM MAINTENANCE	TOO FAST SUPPLY	DIAMOND BLADE	32.92	
520-520-54390	SYSTEM MAINTENANCE	USA BLUE BOOK	PERSONAL LOCKOUT KITS	448.86	
520-520-54420	WELL MAINTENANCE	MCCROMETER INC	PCB ASSY	595.24	
520-520-55640	COMPLIANCE TESTING	NEBRASKA PUBLIC HEALTH	WATER TESTING	1,428.00	
520-520-56010	SUPPLIES	EAKES OFFICE SOLUTIONS	CENTER PULL TOWELS	41.27	
520-520-56010	SUPPLIES	HADLEY-BRAITHWAIT COMPANY	MULTIFOLD TOWELS, TOILET PAPER	86.94	
520-520-56020	OFFICE SUPPLIES	EAKES OFFICE SOLUTIONS	PERFERED PAPER	109.90	
520-520-56030	CLEANING SUPPLIES/SERVICE	JACKSON SERVICES INC	2 SOAP FOAM BAGS	18.00	
520-520-56040	POSTAGE AND FREIGHT	CASEY'S MAIL SERVICE LLC	DAILY POSTAGE, WATER STATEMENTS	2,067.26	
520-520-56060	CHEMICALS	HAWKINS INC	CHEMICALS	10,328.41	
520-520-56100	LABORATORY	USA BLUE BOOK	HACH FLORIDE, TOTAL PHOSPHATE TNT SET,	1,463.59	
520-520-56190	PERSONAL PROTECTIVE SUPP	BOMGAARS	2 - JACKETS - LINED HI-V	59.99	
520-520-56230	WATER AND SEWER	CITY OF COLUMBUS	WATER & SEWER	164.54	
520-520-56240	TELEPHONE	GREAT PLAINS COMMUNICATION	PHONE/INTERNET CHARGES 05/16 - 06/15	55.36	
520-520-57200-22031	CAPITAL-LAND & BUILDINGS	HDR ENGINEERING INC	DESIGN/CONSTRUCTION PHASE SERVICES LOST	2,470.36	
		Total For Dept 520 WATER		24,999.31	
		Total For Fund 520 WATER		25,012.49	
Fund 560 STORMWATER UTILITY					
Dept 000					
560-000-20100	SUF-5	BEHLE NICHOLAS	UB refund for account: 300-58440-04	3.20	
		Total For Dept 000		3.20	
Dept 560 STORMWATER UTILITY					
560-560-53400	COMPUTER SUPPORT/MAINT	LABORDE, ADAM	GIS SUPPORT SERVICES MARCH/APRIL 2023	130.00	
560-560-56020	OFFICE SUPPLIES	BENCK BRIAN D	REIMBURSE PURCHASE AT MENARDS	245.31	
560-560-56020	OFFICE SUPPLIES	EAKES OFFICE SOLUTIONS	HANGING LEGAL FOLDERS	56.67	
560-560-56230	WATER AND SEWER	CITY OF COLUMBUS	WATER & SEWER	43.16	
		Total For Dept 560 STORMWATER UTILITY		475.14	
		Total For Fund 560 STORMWATER UTILITY		478.34	
Fund 570 SOLID WASTE DIVISION					
Dept 000					
570-000-20100	SWD-1	BEHLE NICHOLAS	UB refund for account: 300-58440-04	1.99	
		Total For Dept 000		1.99	
Dept 570 TRANSFER STATION					
570-570-52800	UNIFORMS	JACKSON SERVICES INC	UNIFORMS	358.86	

UNJOURNALIZED
 BOTH OPEN AND PAID

GL Number	Invoice Line Desc	Vendor	Invoice Description	Amount	Check #
Fund 570 SOLID WASTE DIVISION					
Dept 570 TRANSFER STATION					
570-570-54310	BUILDING MAINTENANCE	ACE HARDWARE & GARDEN CNT	KEY KWIKSET, NUTS, BOLTS, WASHER, O-RIN	7.26	
570-570-54310	BUILDING MAINTENANCE	MENARDS	FENDER WASHER, LAG SCREW, 4X4-12' AC2 C	117.57	
570-570-54320	EQUIPMENT MAINTENANCE	PRODUCTIVITY PLUS ACCOUNT-	ELEC CONT UNIT, REMANSENSOR	949.02	
570-570-54320	EQUIPMENT MAINTENANCE	SAPP BROS COLUMBUS INC	AMERIGUARD 15W-40 HD & HYDRAULIC	623.50	
570-570-54330	VEHICLE MAINTENANCE	KELLY SUPPLY COMPANY	1" ISO-A SEAL KIT	10.05	
570-570-54330	VEHICLE MAINTENANCE	MENARDS	COMPRESSION INSERT & SLEEVE, VACUUM BRE	18.23	
570-570-54330	VEHICLE MAINTENANCE	POMP'S TIRE SERVICE INC.	TIRE REPAIR	3,696.30	
570-570-54330	VEHICLE MAINTENANCE	SAPP BROS COLUMBUS INC	AMERIGUARD 15W-40 HD & HYDRAULIC	832.50	
570-570-54330	VEHICLE MAINTENANCE	TIRE OUTLET INC	USED TIRE	45.00	
570-570-54330	VEHICLE MAINTENANCE	TRUCK CENTER COMPANIES	DRAIN VALVE	122.65	
570-570-54330	VEHICLE MAINTENANCE	WELDON PARTS NORTH BEND	AIR BAG	136.32	
570-570-55900	MISCELLANEOUS	SCHIEFFER SIGNS INC	METAL SIGN	432.00	
570-570-56010	SUPPLIES	MENARDS	REDUCER, HOSE REPAIR KIT, PVC AIR HOSE,	79.92	
570-570-56020	OFFICE SUPPLIES	CAROLINA SOFTWARE	WASTE WORKS LASER TICKETS	790.86	
570-570-56030	CLEANING SUPPLIES/SERVICE	JACKSON SERVICES INC	MATS, ROLLER TOWELS, UNIFORMS	68.32	
570-570-56050	FUEL	MENARDS	2.5 GAL DEF	113.76	
570-570-56050	FUEL	SAPP BROS COLUMBUS INC	FUEL	9,097.30	
570-570-56230	WATER AND SEWER	CITY OF COLUMBUS	WATER & SEWER	257.62	
570-570-56240	TELEPHONE	GREAT PLAINS COMMUNICATION	PHONE/INTERNET CHARGES 05/16 - 06/15	21.90	
Total For Dept 570 TRANSFER STATION				17,778.94	
Total For Fund 570 SOLID WASTE DIVISION				17,780.93	
Fund 730 LICENSES TO SCHOOLS					
Dept 730 LICENSES TO SCHOOLS					
730-730-56710	SCHOOL DISTRICT	SCHOOL DISTRICT #1	LIQUOR AND TOBACCO REVENUE PAYMENT	15,502.50	
Total For Dept 730 LICENSES TO SCHOOLS				15,502.50	
Total For Fund 730 LICENSES TO SCHOOLS				15,502.50	

UNJOURNALIZED
BOTH OPEN AND PAID

GL Number	Invoice Line Desc	Vendor	Invoice Description	Amount	Check #
-----------	-------------------	--------	---------------------	--------	---------

Fund Totals:

Fund 100 GENERAL FUND	335,318.85
Fund 200 STREETS/ENGINEER	1,298,836.12
Fund 205 AIRPORT	43,689.59
Fund 211 1/2 CENT SALES	42,499.99
Fund 220 COMMUNICATIONS	1,329.95
Fund 240 HOUSING REHAB	3,497.93
Fund 500 UTILITY SERVICE	64,992.29
Fund 520 WATER	25,012.49
Fund 560 STORMWATER UTIL	478.34
Fund 570 SOLID WASTE DIV	17,780.93
Fund 730 LICENSES TO SER	15,502.50

Total For All Funds:	<u>1,848,938.98</u>
----------------------	---------------------

5. APPROVAL OF MINUTES - Included in Consent Agenda

6. SPECIAL PRESENTATIONS - None

7. PUBLIC HEARINGS

7.A. Public hearing - consider proposed Downtown Business Improvement District No. 3 (general vicinity from alley south of 11 Street to alley north of 14 Street between 23 Avenue and 33 Avenue and Evans House, 2204 14 Street).



The City of Columbus

RESPONSIBLE • RESPONSIVE • REPUTABLE

Administration Office (402) 562-4232

Fax (402) 563-1380

memorandum

DATE: May 17, 2023
TO: Tara Vasicek, City Administrator
FROM: Jean Van Iperen, Planning & Economic Development Coordinator
RE: Creation of Business Improvement District (BID)

RECOMMENDATION:

Approval of the Ordinance to create and establish a new Downtown Business Improvement District.

DISCUSSION:

In February a public hearing was held to discuss the formation of a proposed BID with boundaries and an assessment method. Prior to the public hearing, educational material was sent to the property owners in the area through two different mailings. The first mailing went out in October 2022 and provided basic information about BIDs, what authority the city has in establishing them, a list of possible projects funding could be used for and how the BID could fund improvements. A second letter to property owners was sent out after feedback from property owners was received. Adjustments to the district boundaries were made and additional discussion was held at length on how the property assessment would be handled. The public hearing was held in the later part of February by the City Council regarding the formation of the district. At that time the City Council passed a resolution appointing Josh Johnson, Kevin Johnson, Kristin Stock, Barbara Duffy, Lindsay Thomson, Mary Nyffeler, Robert Stachura, Cory Reeder, and Dick Tooley to a Downtown Business Improvement Development Board to further explore the potential establishment of a district with a funding source to make improvements within the boundaries established by the Board.

After that initial public hearing, the Board immediately took on the task of reviewing the boundaries for the district. After discussion regarding the size it was determined the boundaries needed to be adjusted. The boundaries proposed was the outcome of those conversations. The next task they looked at was the assessment. They discussed a tier assessment; fixed assessment; assessment based on square footage, lot footage or front footage; and an assessment based on valuation. After several meetings, the Board came to the consensus an assessment based on valuation was the most fair. Therefore, the Board is proposing a \$200 assessment per \$100,000 valuation with a \$750 cap per year per property. This assessment will yield approximately \$45,827.25 in year one. With the City having agreed to match funds generated by the assessment dollar for dollar this would give the BID Board a first-year budget of approximately \$91,654.52. Owner-occupied single-family residences will be excluded from the assessment as are tax-exempt properties such as churches and government owned properties.

Once these items were established, the BID Board held a town hall meeting on Tuesday, April 18, to present information to the public. The Board talked about the boundaries, assessment and proposed projects. The next scheduled meeting of the Board following the Town Hall, the group considered the comments made by the



attendees of the Town Hall and finalized their targeted project activities for the first year. The Board will be utilizing the money collected in the first year towards downtown banners and necessary hardware, advertising and marketing, directional signage, Christmas lighting and decorations, planter boxes and trash receptacles.

In order to promote transparency, BID meetings, highlights and reminders are announced on the City's Twitter, Instagram, and Facebook pages, on the City website, and published in the Columbus Telegram. The Town Hall meeting was publicized on the City's social media and website pages, on electronic signs placed in two different locations within the district. A press release was also sent to all area media. The Columbus Telegram also published articles prior to and after the BID Town Hall meetings informing the public. A notice of this public hearing was published in the Columbus Telegram and letters were mailed out on May 17, 2023 to all property owners within the proposed district boundaries as required by State Statute 19-4029.01. Notification regarding the mailing of the letters was also posted on the City's social media outlets and on the City website.

The material sent to the property owners is included with this memo.

FISCAL IMPACT:

The Council previously approved a dollar for dollar match of the assessment amount generated each year. First year approximately \$45,827.25.

ALTERNATIVE:

Not approve the Ordinance

SIGNATURE:

By: 

Approved by:  _____



The City of Columbus

RESPONSIBLE • RESPONSIVE • REPUTABLE

Administration Office (402) 562-4232

Fax (402) 563-1380

May 16, 2023

<Property Owners Name
Address>

<Legal Description>

RE: Proposed Business Improvement District #3 and proposed assessment

In January 2023, the City of Columbus sent you information concerning the establishment of a possible Downtown Business Improvement District (BID). To explore this proposal, the City Council appointed nine business owners and/or property owners to a BID Board to explore the need for the district and funding options. Board members appointed by the Council were Josh Johnson, of Columbus Bank and Trust; Kevin Johnson, of Wize Buys, who is also board vice chairman; Barbara Duffy, of Barbara Jean’s, who is the board secretary; Mary Nyffeler, of Treasures Boutique; Cory Reeder, of Reeder’s; Robert “Bob” Stachura, of Columbus Tire and Service Center; Lindsay Thomson, of Inspired by Soul Photography; Dick Tooley of Tooley’s Drug & Home Care; and Kristin Stock, of Artzy Haven.

Since that time, the Board has been meeting to set boundaries, elevate projects and propose assessments and a budget. Last month, the Board held a town hall meeting to gain additional feedback from property/business owners regarding their proposed plans. Taking into consideration comments gathered when talking to business and property owners, the Board now feels comfortable taking their recommendation to the City Council.

The Board is proposing a special assessment that is based on a \$200 assessment per \$100,000 of real property valuation per county records, with a \$750 cap per property. The assessment would net \$45,827.26 in year one. The City has agreed to match funds generated by the assessment \$1 to \$1 giving the BID Board a first-year budget of approximately \$91,654.52. If approved the BID would be reevaluated in 5 years. The City has committed to matching \$1 for \$1 what the BID generates for those five years. Owner-occupied single-family residences will be excluded from the assessment as are tax-exempt properties such as churches and government owned properties. Based on the most recent assessed value of your property of \$<current assessed value of property per county records>, your first year’s assessment would be \$<proposed assessment>.

During the first year, the BID Board is proposing projects that include: downtown banners and necessary hardware, advertising and marketing, directional signage, Christmas lighting and decorations, planter boxes, and trash receptacles.

A public hearing with the City Council is scheduled for 7:00 p.m. June 5 at the Columbus Council Chambers, 1369 25th Avenue. Property owners do have a right to express their views at the public hearing.

According to Nebraska Revised Statute 19-4027, the public hearing will terminate if **written protest** is made prior to the close of the hearing by the record owners of over 50 percent of the assessable units in the proposed business improvement district.



A postcard has been enclosed with this letter providing you with a convenient way to express your support or opposition in writing for the formation of the BID. The card must be fully completed and received via email to jean.vaniperen@columbusne.us, mail or hand delivered to City Hall, Planning & Economic Development, 2424 14th Street by 5 p.m. on Monday, June 5. If mailing your card please remember to allow the post office enough time to get it delivered prior to the meeting.

Enclosures with this letter include a picture of the boundaries of the BID, a copy of the public notice, and a postcard.

For additional information about the district or to ask questions you may contact Jean Van Iperen, Planning & Economic Development Coordinator for the City of Columbus at 402-562-4273 or email her at jean.vaniperen@columbusne.us.

ORDINANCE NO. 23-_____

AN ORDINANCE OF THE MAYOR AND COUNCIL OF THE CITY OF COLUMBUS, NEBRASKA CREATING AND ESTABLISHING THE BOUNDARIES, PURPOSES, AND ASSESSMENT METHOD FOR THE DOWNTOWN BUSINESS IMPROVEMENT DISTRICT; REPEALING ALL ORDINANCES OR PORTIONS THEREOF IN CONFLICT HEREWITH; PROVIDING FOR AN EFFECTIVE DATE; AND PROVIDING FOR THE PUBLICATION OF THIS ORDINANCE IN PAMPHLET FORM.

WHEREAS, the Business Improvement District Act, pursuant to Neb. Rev. Stat. § 19-4015 to § 19-4038, as amended, allows Cities to create business districts and raise funds to be used for the purposes of providing and maintaining improvements authorized by said Act; and

WHEREAS, under the Business Improvement District Act Cities may impose special assessments on owners of property within the district and/or a general occupation tax on businesses or uses of space within the district; and

WHEREAS, the City Council previously conducted a public hearing on February 21, 2023, and passed Resolution R23-31 declaring an intent to create and establish the Downtown Business Improvement District, and further said resolution created an initial board (the Business Improvement Board) for this Downtown Business Improvement District; and

WHEREAS, this Business Improvement Board has conducted multiple public meetings (with published meeting notices, social media notices, notices on the city website, etc.) and spoken with numerous stakeholders and affected property owners in the proposed Downtown Business Improvement District's boundaries; and

WHEREAS, the City's Business Improvement Board has made a recommendation to the Mayor and City Council to formally establish and create the new "Downtown Business Improvement District" for the construction, repair, maintenance, etc. of public facilities and improvements within the district, has made a recommendation as to the funding source and method by special assessment for said district, and has requested modifying (by shrinking) the district's original boundaries, all as further described in this Ordinance; and

WHEREAS, the City's Business Improvement Board District has made a recommendation to the City Council to formally adopt an Ordinance creating, establishing, and governing this Downtown Business Improvement District; and

WHEREAS, Notice of Hearings for the creation and formation of this Downtown Business Improvement District and Ordinance were published and mailed as required by law and a public hearing was held concerning the creation and formation of the Downtown Business Improvement District on:

June 5, 2023, at 7:00 p.m. in the City Council Chambers at 1369 25th Ave., Columbus, Nebraska; and

WHEREAS, the proposed Downtown Business Improvement District is located

within the boundaries of an established area of the City zoned for business, public, or commercial purposes; and

WHEREAS, the City Council now finds and determines that the Downtown Business Improvement District shall be created in accordance with state law.

NOW, THEREFORE, BE IT ORDAINED BY THE MAYOR AND COUNCIL OF THE CITY OF COLUMBUS, NEBRASKA:

Section 1. There is hereby created and established a business improvement district to be known as the "Downtown Business Improvement District".

Section 2. The purpose, public facilities and improvements to be made or maintained within the Downtown Business Improvement District include: district advertising and marketing; legal notices; events in the district; wayfinding signage; parking lot improvements; streetscape; lighting; beautification; art; and landscaping; as well as maintenance and construction, repair, and reconstruction of any improvements or facilities authorized by the Business Improvement District Act.

Section 3. Pursuant to Resolution No. R23-31 the boundaries of the Downtown Business District were proposed to be:

Beginning at the NW corner Lot 5, Block C, Beckers Subdivision of Outlot 8 to the City of Columbus, Platte County, Nebraska; thence easterly on the north line Lots 5, 6, 7, and 8, said Block C, to the NE corner Lot 8, said Block C; thence easterly to the NW corner Lot 3, Block B, said Subdivision; thence easterly on the north line Lots 3 and 4, Block B, said Subdivision, to the NE corner Lot 4, Block B, said Subdivision; thence southwesterly to the NW corner Lot 3, Block A, said Subdivision; thence easterly on the North line Lots 3 and 4, Block A, said Subdivision to the NE corner Lot 4, Block B, said Subdivision; thence continuing on the easterly extension of said Lots 3 and 4 to its intersection with the centerline 30th Street; thence northerly and on said centerline to its intersection with the westerly extension of the North line Lots 5, 6, 7, and 8, Block 54, Original City of Columbus, Platte County, Nebraska; thence easterly and on said North line to the NE corner Lot 8, said Block 54; thence easterly to the NW corner Lot 5, Block 53, Original City of Columbus, Platte County, Nebraska; thence easterly and on the North line Lots 5, 6, 7, and 8 said Block 53 to its intersection with the centerline 28th Avenue; thence northerly and on said centerline to its intersection with the westerly extension of the North line Lots 1, 3, and 4, Block 3, Stevens Addition to the City of Columbus, Platte County, Nebraska; thence easterly and on said North line to the NE corner Lot 1, said Block 3; thence easterly to the NW corner Lot 4, Block 2, said Stevens Addition; thence easterly and on the North line Lots 1, 2, 3, and 4, said Block 2, to the NE corner, Lot 1, said Block 2; thence easterly to the NW corner Lot 2, Block 1 said Stevens Addition; thence easterly and on the North line said Lot 2, Block 1, to the NE corner said Lot 2, Block 1; thence northeasterly to the NW corner of the S56' N168' E132', Block 16, Becher Place Addition to the City of Columbus, Platte County, Nebraska; thence easterly and on the North line of the S56' N168' E132' said Block 16 to the

NE corner of the S56' N168' E132' said Block 16; thence southeasterly to the NW corner Lot 5, Block 17, said Addition; thence easterly and on the North line Lots 5, 6, 7, and 8 said Block 17 to the NE corner Lot 8, said Block 17; thence easterly to the NW corner Lot 5, Block 18, said Addition; thence easterly and on the North line Lots 5, 6, 7, and 8 said Block 18 to its intersection with the centerline 23rd Avenue; thence southerly and on the centerline 23rd Avenue to its intersection with the centerline 15th Street; thence easterly and on the centerline 15th Street to its intersection with the centerline 22nd Avenue; thence southerly and on the centerline 22nd Avenue to its intersection with 14th Street; thence easterly and on the centerline 14th Street to its intersection with the centerline 21st Avenue; thence southerly and on the centerline 21st Avenue to its intersection with the North Right-of-Way line UPPR Railroad; thence westerly and on said North line to the SE corner Lot 8, Block 80, Original City of Columbus, Platte County, Nebraska; thence northwesterly and on the South line Lots 5, 6, 7, and 8, said Block 80 to the SW corner Lot 5, said Block 80; thence northerly and on the West line said Lot 5 to the SW corner Lot 4 said Block 80; thence westerly to the SE corner Lot 1, Block 81, said Original City; thence southerly to the SE Corner Lot 8, said Block 81; thence northwesterly on the South line Lots 5, 6, 7, and 8, said Block 81, to the SW corner Lot 5, Said Block 81; thence northerly to the NW corner Lot 5, said Block 81; thence westerly to the NE corner Lot 8, Block 82, said Original City; thence southerly to the SE corner Lot 8, said Block 82; thence southwestery and on the South line Lots 5, 6, 7, and 8, said Block 82 to the SW corner Lot 5, said Block 82; thence northerly to the NW corner Lot 5, said Block 82; thence westerly and on the westerly extension of the North line Lots 5, 6, 7, and 8, said Block 82, 58 feet; thence southerly and parallel to the West line Lot 5, said Block 82 to its intersection with the northeasterly extension of the South line Lots 5, 6, 7, and 8, Block 83 said Original City; thence southwestery and on said extension to the SW corner Lot 5, said Block 83; thence southerly and on the extension of the West line said Lot 5 to its intersection with the easterly extension of the South line Block 84 said Original City; thence westerly on said extension to the SW corner Block 84 said Original City; thence southerly and on the extension of the West line said Block 84 to its intersection with the centerline 12th Street; thence westerly and on the centerline 12th Street to the SE corner Lot 3, Union Pacific Subdivision; thence westerly and on the South line said Subdivision to the SW corner said Subdivision; thence southerly and on the East line, Outlot 7, Columbus Outlots to the City of Columbus, Platte County, Nebraska to the SE corners said Outlot 7; thence westerly and on said South line to the SW corner said Outlot 7, said point also being on the East Right-of-Way line 33rd Avenue; thence northerly and on said East line to the Point of Beginning,

Also Beginning at the NW corner Block 122, Original City of Columbus, Platte County, Nebraska; thence easterly on the North line Block 121 and 122, said Original City to its intersection with the centerline 28th Avenue; thence northerly on centerline 28th Avenue to its intersection with the centerline 11th Street; thence easterly on the centerline 11th Street to its intersection with the centerline 25th Avenue; thence northerly on the

centerline 25th Avenue its intersection with the southerly Right-of-Way line Union Pacific Railroad; thence easterly and on said southerly line to the West line Block 94, said Original City; thence North on said West line to the NW corner Lot 5, said Block 94; thence easterly on the North line Lots 5, 6, 7, and 8, said Block 94 to the NE corner Lot 8, said Block 94; thence southeasterly to the NW corner Lot 5, Block 95, said Original City; thence easterly on the North line Lots 5, 6, 7, and 8, Block 95, said Original City, to its intersection with the centerline 23rd Avenue; thence northerly on the centerline 23rd Avenue to its intersection with the southerly Right-of-Way line Union Pacific Railroad; thence easterly and on said southerly line to its intersection with the West line, Block 96, said Original City; thence northerly on said West line to the NW corner said Block 96; thence easterly on the north line said Block 96 to its intersection with the centerline 22nd Avenue; thence southerly and on the centerline 22nd Avenue to its intersection with the easterly extension of the south line Lots 1, 2, 3, and 4, Blocks 115 through 122, said Original City; thence westerly on said South line to the SW corner Lot 4, Block 122, said Original City; thence northerly on the West line said Block 122 to the Point of Beginning.

The Business Improvement Board has reviewed said proposed boundaries and has instead proposed modification of these boundaries to shrink the affected area. This modification is approved. Therefore, the new legal description of the modified boundaries of the Downtown Business Improvement District shall be and is described as follows:

Beginning at the intersection of the centerline 33rd Avenue and the westerly extension of the south line Lot 4, Block C, Becker's Subdivision to the City of Columbus, Platte County, Nebraska; thence easterly to the intersection of the centerline 30th Avenue and the westerly extension of the south line Lot 4, Block 55, Original City of Columbus; thence northerly and on the centerline 30th Avenue to its intersection with the westerly extension of the south line Lot 4, Block 54, Original City of Columbus, thence easterly and on the south line of Lots 1 thru 4, Blocks 47 thru 54, to its intersection with centerline 22nd Avenue; thence southerly and on the centerline of 22nd Avenue to its intersection with the centerline 14th Street; thence westerly and on the centerline 14th Street to its intersection with the centerline 23rd Avenue; Thence southerly and on the centerline 23rd Avenue to its intersection with the easterly extension of the south line Lot 1, Block 116, Original City of Columbus ; thence westerly and on the westerly extension of the south line Lots 1 thru 4, Blocks 116 thru 122 to its intersection with the centerline 33rd Avenue; thence northerly and on the centerline 33rd Avenue to the Point of Beginning.

Section 4. The real property located within the boundaries of the Downtown Business Improvement District shall be subject to special assessment.

Section 5. The method of special assessment to be imposed within the Downtown Business Improvement District shall be yearly special assessment, with single family residences excluded from said assessment. The yearly special assessment paid by the affected property owners within the Downtown Business Improvement District would be based on the county's assessed value of the property. A \$200 assessment per \$100,000 of valuation with a \$750.00 cap per property per year

for as long as this Downtown Business Improvement District is in existence shall be used for the assessment calculation for all affected properties.

Section 6. Pursuant to Neb. Rev. Stat. § 19-4037 the City and the Downtown Business Improvement District is authorized to receive, administer, and disburse donated funds or grants of federal or state or local funds for the purposes of and in the manner authorized by the Business Improvement District Act.

Section 7. The mayor has previously, with the approval of the City Council, appointed a Business Improvement Board consisting of property owners, residents, business operators, and users of space within the district, said board shall continue with its roles and responsibilities.

Section 8. At least every five years after the passage of this Ordinance the Business Improvement Board, shall meet and evaluate the improvements made, plans for future improvement, and overall success of this Downtown Improvement District and shall make a report to the City Council and Mayor about any desire to either keep this Downtown Improvement District or disband it.

Section 9. If any section, subsection, phrases, or clause, of this ordinance is, for any reason, held to be unconstitutional or invalid, such holding shall not affect the validity of the reaming portions of this ordinance.

Section 10. This Ordinance shall repeal all Ordinances or portions thereof and conflict herewith.

Section 11. This Ordinance shall be in full force and effect from and after its passage, approval, and publication according to law. Publication shall be in pamphlet form as authorized by Neb. Rev. Stat. § 16-405 with distribution to be made by making copies available to the public upon request at the City office.

INTRODUCED BY COUNCIL MEMBER _____

PASSED AND ADOPTED THIS ____ DAY OF _____, 2023.

MAYOR

ATTEST:

CITY CLERK

APPROVED AS TO FORM:

CITY ATTORNEY

NOTICE OF PUBLIC HEARING

Notice is hereby given that the Mayor and Council of the City of Columbus, Nebraska, will conduct a Public Hearing on June 5, 2023, at 7:00 p.m., in the City's Council Chambers (1369 25th Ave., Columbus, NE). This hearing will concern the creation of a Downtown Business Improvement District. At said time and place of said Public Hearing you may appear and be heard.

The City anticipates collecting a yearly assessment from all the property owners located within the established boundaries of the proposed Downtown Business Improvement District, with single family residences excluded from assessment. The money collected would be used solely by the district for specific projects selected by and budgeted for by the Downtown Business Improvement District Board. The board will be made up of business/property owners within the district. Projects funded through the Downtown Business Improvement District are intended to enhance, not replace, existing city services. The proposed public facilities and improvements to be made or maintained within the Downtown Business Improvement District include: district advertising and marketing, directional signage, Christmas lighting and decorations, events in the district, parking lot improvements, streetscape, lighting, beautification, and landscaping.

The yearly assessment paid by the affected property owners within the district would be based on the county's assessed value of the property. A \$200 assessment per \$100,000 of valuation would be used for the assessment calculation for all affected properties with a \$750 cap per property per year. If approved, this year's assessment will generate \$45,827.26 and the proposed revenue would total \$91,654.52 which includes a dollar for dollar city match.

The legal description of the boundaries of the proposed Downtown Business Improvement District is: Beginning at the intersection of the centerline 33rd Avenue and the westerly extension of the south line Lot 4, Block C, Becker's Subdivision to the City of Columbus, Platte County, Nebraska; thence easterly to the intersection of the centerline 30th Avenue and the westerly extension of the south line Lot 4, Block 55, Original City of Columbus; thence northerly and on the centerline 30th Avenue to its intersection with the westerly extension of the south line Lot 4, Block 54, Original City of Columbus, thence easterly and on the south line of Lots 1 thru 4, Blocks 47 thru 54, to its intersection with centerline 22nd Avenue; thence southerly and on the centerline of 22nd Avenue to its intersection with the centerline 14th Street; thence westerly and on the centerline 14th Street to its intersection with the centerline 23rd Avenue; Thence southerly and on the centerline 23rd Avenue to its intersection with the easterly extension of the south line Lot 1, Block 116, Original City of Columbus ; thence westerly and on the westerly extension of the south line Lots 1 thru 4, Blocks 116 thru 122 to its intersection with the centerline 33rd Avenue; thence northerly and on the centerline 33rd Avenue to the Point of Beginning.

For additional information about the district or to ask questions you may contact Jean Van Iperen, Planning & Economic Development Coordinator for the City of Columbus at 402-562-4273 or email her at jean.vaniperen@columbusne.us.

JANELLE KLINE, CMC
CITY CLERK

EXHIBIT

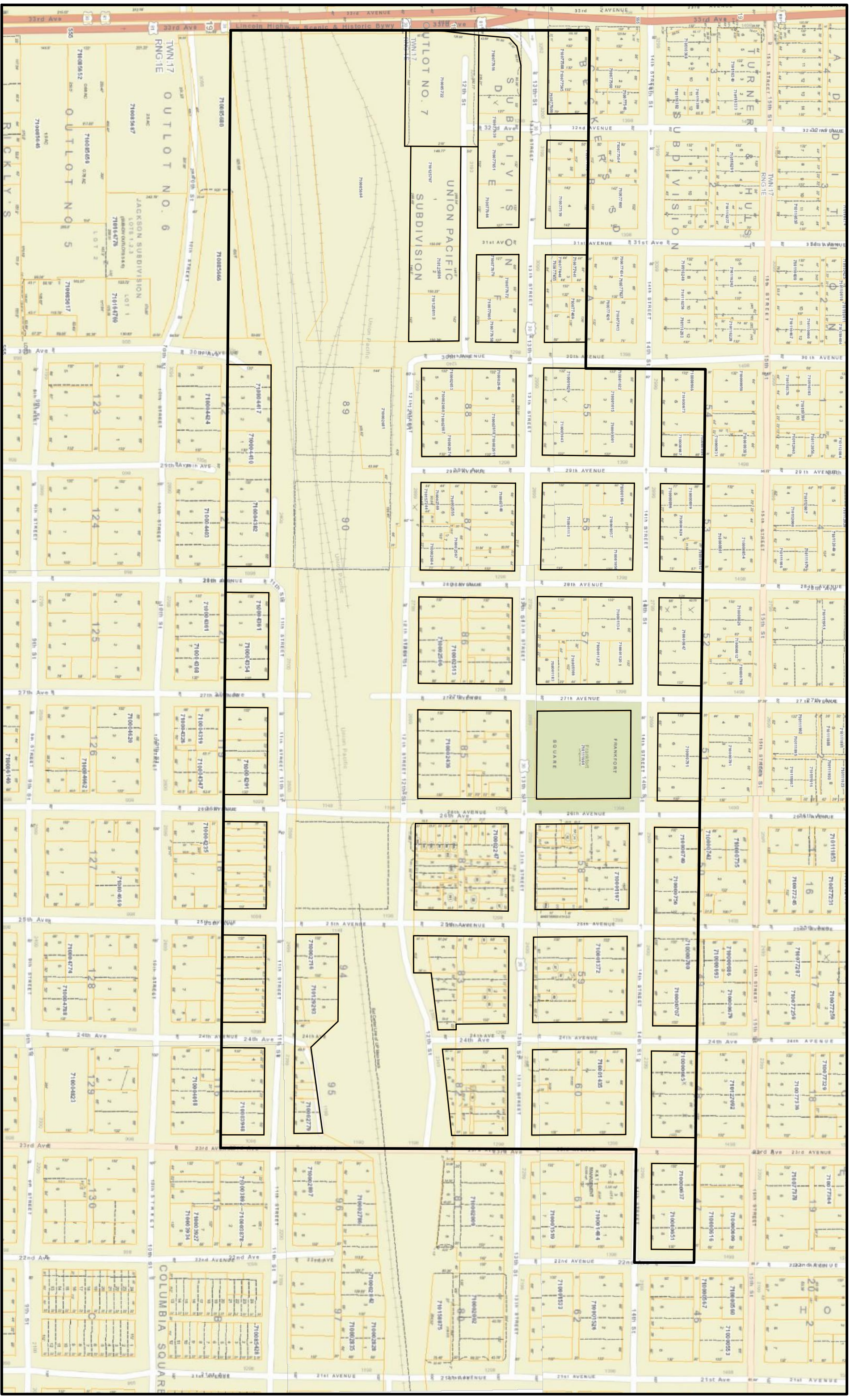

May 16, 2023

Survey on Creation of Business Improvement District

_____ I am in support of the creation of this BID

_____ I am not in support of the creation of this BID

<Property owners name & address>

<Legal Description>



The City of Columbus

RESPONSIBLE • RESPONSIVE • REPUTABLE

Administration Office (402) 562-4232

Fax (402) 563-1380

memorandum

DATE: June 5, 2023
TO: Tara Vasicek, City Administrator and City Council
FROM: Jean Van Iperen, Planning & Economic Development Coordinator
RE: BID Postcard results

DISCUSSION:

When discussion concerning the establishment of a BID came before the Council back in February and questions were asked about the postcard response, Councilman Prent Roth suggested providing a map that showed the proposed BID boundaries, properties that would be exempt from the BID, properties that voted for creation of the BID and properties that voted against the creation of the BID. The attached map shows all of those above-mentioned items. Any owner of property located within the proposed boundaries was sent a letter, map and postcard concerning the BID on May 16 with the exception of government, church and utility owned properties shown in yellow and the single-family owner-occupied properties shown in brown. There were 198 postcards sent. This map shows the responses received in City Hall as of 3:55 p.m. on June 5, 2023. The "yes" responses are in green and the "no" responses are in red. The light blue represents a letter that was sent and returned with no forwarding address provided.

In February, Councilman Roth also suggested providing comparisons based on the measures of assessed property valuation of the "yes" and "no" voters as well as a comparison of the assessment value of the "yes" and "no" votes. That breakdown is as follows:

198 potential votes

46 – yes
56 – no
51.52% of the postcards turned in

Total Valuation -- \$27,707,170.00

\$8,004,601.41 – yes
\$7,613,930.32 – no

Total Assessment -- \$45,434.96

\$13,126.16 – yes or 28.89%
\$12,485.53 – no or 27.48%



EXHIBIT

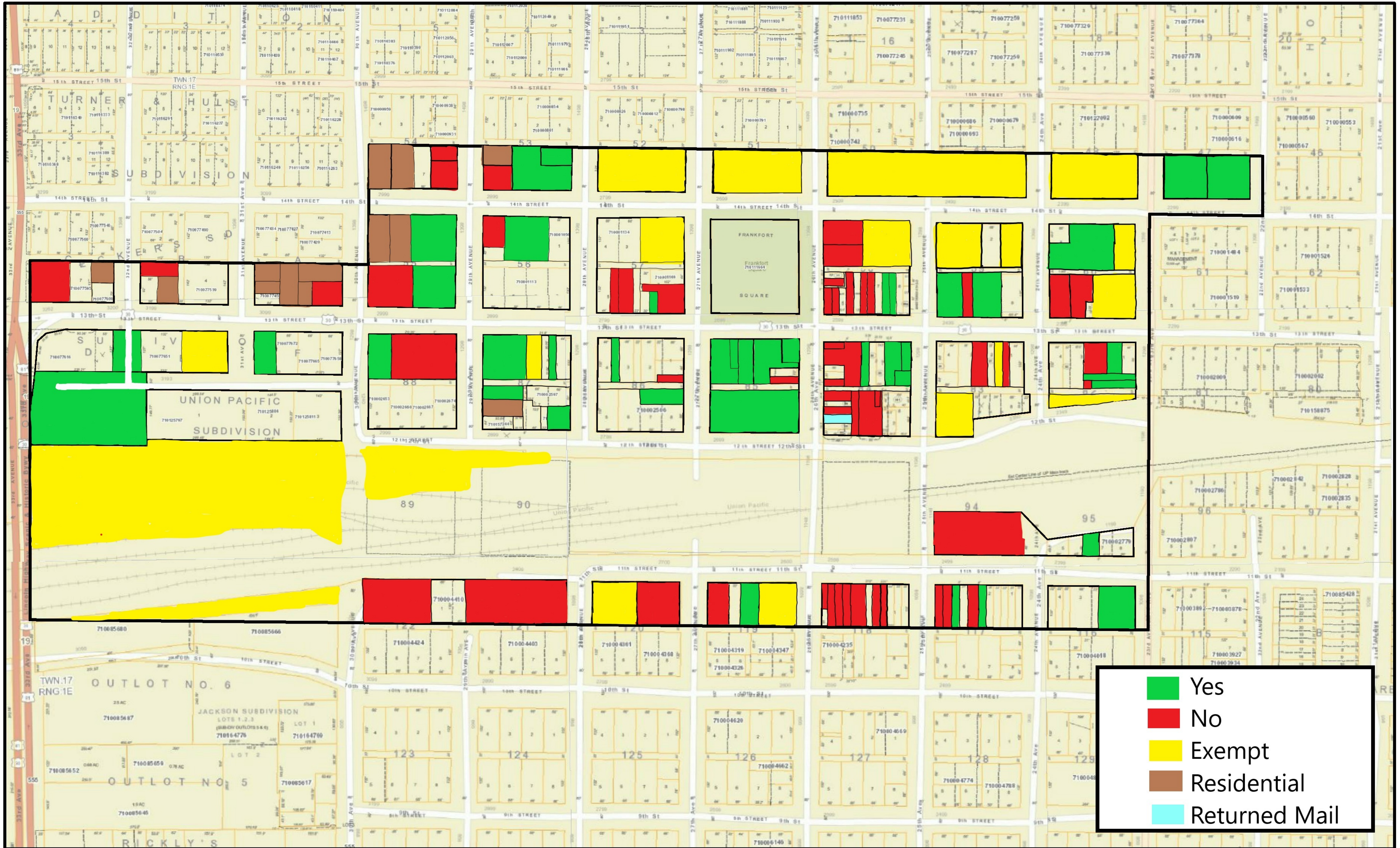

7.A.1. Ordinance No. 23-05 creating Downtown Business Improvement District No. 3.

Draft

ORDINANCE NO. 23-05

AN ORDINANCE OF THE MAYOR AND COUNCIL OF THE CITY OF COLUMBUS, NEBRASKA CREATING AND ESTABLISHING THE BOUNDARIES, PURPOSES, AND ASSESSMENT METHOD FOR THE DOWNTOWN BUSINESS IMPROVEMENT DISTRICT; REPEALING ALL ORDINANCES OR PORTIONS THEREOF IN CONFLICT HEREWITH; PROVIDING FOR AN EFFECTIVE DATE; AND PROVIDING FOR THE PUBLICATION OF THIS ORDINANCE IN PAMPHLET FORM.

WHEREAS, the Business Improvement District Act, pursuant to Neb. Rev. Stat. § 19-4015 to § 19-4038, as amended, allows Cities to create business districts and raise funds to be used for the purposes of providing and maintaining improvements authorized by said Act; and

WHEREAS, under the Business Improvement District Act Cities may impose special assessments on owners of property within the district and/or a general occupation tax on businesses or uses of space within the district; and

WHEREAS, the City Council previously conducted a public hearing on February 21, 2023, and passed Resolution R23-31 declaring an intent to create and establish the Downtown Business Improvement District, and further said resolution created an initial board (the Business Improvement Board) for this Downtown Business Improvement District; and

WHEREAS, this Business Improvement Board has conducted multiple public meetings (with published meeting notices, social media notices, notices on the city website, etc.) and spoken with numerous stakeholders and affected property owners in the proposed Downtown Business Improvement District's boundaries; and

WHEREAS, the City's Business Improvement Board has made a recommendation to the Mayor and City Council to formally establish and create the new "Downtown Business Improvement District" for the construction, repair, maintenance, etc. of public facilities and improvements within the district, has made a recommendation as to the funding source and method by special assessment for said district, and has requested modifying (by shrinking) the district's original boundaries, all as further described in this Ordinance; and

WHEREAS, the City's Business Improvement Board District has made a recommendation to the City Council to formally adopt an Ordinance creating, establishing, and governing this Downtown Business Improvement District; and

WHEREAS, Notice of Hearings for the creation and formation of this Downtown Business Improvement District and Ordinance were published and mailed as required by law and a public hearing was held concerning the creation and formation of the Downtown Business Improvement District on:

June 5, 2023, at 7:00 p.m. in the City Council Chambers at 1369 25th Ave., Columbus, Nebraska; and

WHEREAS, the proposed Downtown Business Improvement District is located

within the boundaries of an established area of the City zoned for business, public, or commercial purposes; and

WHEREAS, the City Council now finds and determines that the Downtown Business Improvement District shall be created in accordance with state law.

NOW, THEREFORE, BE IT ORDAINED BY THE MAYOR AND COUNCIL OF THE CITY OF COLUMBUS, NEBRASKA:

Section 1. There is hereby created and established a business improvement district to be known as the "Downtown Business Improvement District".

Section 2. The purpose, public facilities and improvements to be made or maintained within the Downtown Business Improvement District include: district advertising and marketing; legal notices; events in the district; wayfinding signage; parking lot improvements; streetscape; lighting; beautification; art; and landscaping; as well as maintenance and construction, repair, and reconstruction of any improvements or facilities authorized by the Business Improvement District Act.

Section 3. Pursuant to Resolution No. R23-31 the boundaries of the Downtown Business District were proposed to be:

Beginning at the NW corner Lot 5, Block C, Beckers Subdivision of Outlot 8 to the City of Columbus, Platte County, Nebraska; thence easterly on the north line Lots 5, 6, 7, and 8, said Block C, to the NE corner Lot 8, said Block C; thence easterly to the NW corner Lot 3, Block B, said Subdivision; thence easterly on the north line Lots 3 and 4, Block B, said Subdivision, to the NE corner Lot 4, Block B, said Subdivision; thence southwesterly to the NW corner Lot 3, Block A, said Subdivision; thence easterly on the North line Lots 3 and 4, Block A, said Subdivision to the NE corner Lot 4, Block B, said Subdivision; thence continuing on the easterly extension of said Lots 3 and 4 to its intersection with the centerline 30th Street; thence northerly and on said centerline to its intersection with the westerly extension of the North line Lots 5, 6, 7, and 8, Block 54, Original City of Columbus, Platte County, Nebraska; thence easterly and on said North line to the NE corner Lot 8, said Block 54; thence easterly to the NW corner Lot 5, Block 53, Original City of Columbus, Platte County, Nebraska; thence easterly and on the North line Lots 5, 6, 7, and 8 said Block 53 to its intersection with the centerline 28th Avenue; thence northerly and on said centerline to its intersection with the westerly extension of the North line Lots 1, 3, and 4, Block 3, Stevens Addition to the City of Columbus, Platte County, Nebraska; thence easterly and on said North line to the NE corner Lot 1, said Block 3; thence easterly to the NW corner Lot 4, Block 2, said Stevens Addition; thence easterly and on the North line Lots 1, 2, 3, and 4, said Block 2, to the NE corner, Lot 1, said Block 2; thence easterly to the NW corner Lot 2, Block 1 said Stevens Addition; thence easterly and on the North line said Lot 2, Block 1, to the NE corner said Lot 2, Block 1; thence northeasterly to the NW corner of the S56' N168' E132', Block 16, Becher Place Addition to the City of Columbus, Platte County, Nebraska; thence easterly and on the North line of the S56' N168' E132' said Block 16 to the

NE corner of the S56' N168' E132' said Block 16; thence southeasterly to the NW corner Lot 5, Block 17, said Addition; thence easterly and on the North line Lots 5, 6, 7, and 8 said Block 17 to the NE corner Lot 8, said Block 17; thence easterly to the NW corner Lot 5, Block 18, said Addition; thence easterly and on the North line Lots 5, 6, 7, and 8 said Block 18 to its intersection with the centerline 23rd Avenue; thence southerly and on the centerline 23rd Avenue to its intersection with the centerline 15th Street; thence easterly and on the centerline 15th Street to its intersection with the centerline 22nd Avenue; thence southerly and on the centerline 22nd Avenue to its intersection with 14th Street; thence easterly and on the centerline 14th Street to its intersection with the centerline 21st Avenue; thence southerly and on the centerline 21st Avenue to its intersection with the North Right-of-Way line UPPR Railroad; thence westerly and on said North line to the SE corner Lot 8, Block 80, Original City of Columbus, Platte County, Nebraska; thence northwesterly and on the South line Lots 5, 6, 7, and 8, said Block 80 to the SW corner Lot 5, said Block 80; thence northerly and on the West line said Lot 5 to the SW corner Lot 4 said Block 80; thence westerly to the SE corner Lot 1, Block 81, said Original City; thence southerly to the SE Corner Lot 8, said Block 81; thence northwesterly on the South line Lots 5, 6, 7, and 8, said Block 81, to the SW corner Lot 5, Said Block 81; thence northerly to the NW corner Lot 5, said Block 81; thence westerly to the NE corner Lot 8, Block 82, said Original City; thence southerly to the SE corner Lot 8, said Block 82; thence southwestery and on the South line Lots 5, 6, 7, and 8, said Block 82 to the SW corner Lot 5, said Block 82; thence northerly to the NW corner Lot 5, said Block 82; thence westerly and on the westerly extension of the North line Lots 5, 6, 7, and 8, said Block 82, 58 feet; thence southerly and parallel to the West line Lot 5, said Block 82 to its intersection with the northeasterly extension of the South line Lots 5, 6, 7, and 8, Block 83 said Original City; thence southwestery and on said extension to the SW corner Lot 5, said Block 83; thence southerly and on the extension of the West line said Lot 5 to its intersection with the easterly extension of the South line Block 84 said Original City; thence westerly on said extension to the SW corner Block 84 said Original City; thence southerly and on the extension of the West line said Block 84 to its intersection with the centerline 12th Street; thence westerly and on the centerline 12th Street to the SE corner Lot 3, Union Pacific Subdivision; thence westerly and on the South line said Subdivision to the SW corner said Subdivision; thence southerly and on the East line, Outlot 7, Columbus Outlots to the City of Columbus, Platte County, Nebraska to the SE corners said Outlot 7; thence westerly and on said South line to the SW corner said Outlot 7, said point also being on the East Right-of-Way line 33rd Avenue; thence northerly and on said East line to the Point of Beginning,

Also Beginning at the NW corner Block 122, Original City of Columbus, Platte County, Nebraska; thence easterly on the North line Block 121 and 122, said Original City to its intersection with the centerline 28th Avenue; thence northerly on centerline 28th Avenue to its intersection with the centerline 11th Street; thence easterly on the centerline 11th Street to its intersection with the centerline 25th Avenue; thence northerly on the

centerline 25th Avenue its intersection with the southerly Right-of-Way line Union Pacific Railroad; thence easterly and on said southerly line to the West line Block 94, said Original City; thence North on said West line to the NW corner Lot 5, said Block 94; thence easterly on the North line Lots 5, 6, 7, and 8, said Block 94 to the NE corner Lot 8, said Block 94; thence southeasterly to the NW corner Lot 5, Block 95, said Original City; thence easterly on the North line Lots 5, 6, 7, and 8, Block 95, said Original City, to its intersection with the centerline 23rd Avenue; thence northerly on the centerline 23rd Avenue to its intersection with the southerly Right-of-Way line Union Pacific Railroad; thence easterly and on said southerly line to its intersection with the West line, Block 96, said Original City; thence northerly on said West line to the NW corner said Block 96; thence easterly on the north line said Block 96 to its intersection with the centerline 22nd Avenue; thence southerly and on the centerline 22nd Avenue to its intersection with the easterly extension of the south line Lots 1, 2, 3, and 4, Blocks 115 through 122, said Original City; thence westerly on said South line to the SW corner Lot 4, Block 122, said Original City; thence northerly on the West line said Block 122 to the Point of Beginning.

The Business Improvement Board has reviewed said proposed boundaries and has instead proposed modification of these boundaries to shrink the affected area. This modification is approved. Therefore, the new legal description of the modified boundaries of the Downtown Business Improvement District shall be and is described as follows:

Beginning at the intersection of the centerline 33rd Avenue and the westerly extension of the south line Lot 4, Block C, Becker's Subdivision to the City of Columbus, Platte County, Nebraska; thence easterly to the intersection of the centerline 30th Avenue and the westerly extension of the south line Lot 4, Block 55, Original City of Columbus; thence northerly and on the centerline 30th Avenue to its intersection with the westerly extension of the south line Lot 4, Block 54, Original City of Columbus, thence easterly and on the south line of Lots 1 thru 4, Blocks 47 thru 54, to its intersection with centerline 22nd Avenue; thence southerly and on the centerline of 22nd Avenue to its intersection with the centerline 14th Street; thence westerly and on the centerline 14th Street to its intersection with the centerline 23rd Avenue; Thence southerly and on the centerline 23rd Avenue to its intersection with the easterly extension of the south line Lot 1, Block 116, Original City of Columbus ; thence westerly and on the westerly extension of the south line Lots 1 thru 4, Blocks 116 thru 122 to its intersection with the centerline 33rd Avenue; thence northerly and on the centerline 33rd Avenue to the Point of Beginning.

Section 4. The real property located within the boundaries of the Downtown Business Improvement District shall be subject to special assessment.

Section 5. The method of special assessment to be imposed within the Downtown Business Improvement District shall be yearly special assessment, with single family residences excluded from said assessment. The yearly special assessment paid by the affected property owners within the Downtown Business Improvement District would be based on the county's assessed value of the property. A \$200 assessment per \$100,000 of valuation with a \$750.00 cap per property per year

for as long as this Downtown Business Improvement District is in existence shall be used for the assessment calculation for all affected properties.

Section 6. Pursuant to Neb. Rev. Stat. § 19-4037 the City and the Downtown Business Improvement District is authorized to receive, administer, and disburse donated funds or grants of federal or state or local funds for the purposes of and in the manner authorized by the Business Improvement District Act.

Section 7. The mayor has previously, with the approval of the City Council, appointed a Business Improvement Board consisting of property owners, residents, business operators, and users of space within the district, said board shall continue with its roles and responsibilities.

Section 8. At least every five years after the passage of this Ordinance the Business Improvement Board, shall meet and evaluate the improvements made, plans for future improvement, and overall success of this Downtown Improvement District and shall make a report to the City Council and Mayor about any desire to either keep this Downtown Improvement District or disband it.

Section 9. If any section, subsection, phrases, or clause, of this ordinance is, for any reason, held to be unconstitutional or invalid, such holding shall not affect the validity of the reaming portions of this ordinance.

Section 10. This Ordinance shall repeal all Ordinances or portions thereof and conflict herewith.

Section 11. This Ordinance shall be in full force and effect from and after its passage, approval, and publication according to law. Publication shall be in pamphlet form as authorized by Neb. Rev. Stat. § 16-405 with distribution to be made by making copies available to the public upon request at the City office.

INTRODUCED BY COUNCIL MEMBER _____

PASSED AND ADOPTED THIS ____ DAY OF _____, 2023.

MAYOR

ATTEST:

CITY CLERK

APPROVED AS TO FORM:

CITY ATTORNEY

7.B. Public hearing - Application of Balaji Petroleum, LLC dba Dual Stop Columbus for Retail Class D liquor license at 3417 14 Street.

**NOTICE OF HEARING
TO ALL PARTIES IN INTEREST AND CITIZENS OF
COLUMBUS, NEBRASKA**

You are hereby notified that a public hearing before the City Council of the City of Columbus, Nebraska, will be held on Monday, June 5, 2023, at 7 p.m. in the Council Chambers, 1369 25 Avenue, Columbus, Nebraska, on the application for a retail liquor license for Balaji Petroleum, LLC dba Dual Stop Columbus, 3417 14 Street, Columbus, Nebraska, and at said time and place you may appear and be heard.

City of Columbus, Nebraska
Janelle Kline, City Clerk

Publish 05:25:23
Two Affidavits of Publication

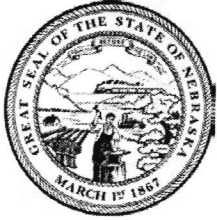

Jim Pillen
Governor

STATE OF NEBRASKA
NEBRASKA LIQUOR CONTROL COMMISSION

Hobert B. Rupe
Executive Director
301 Centennial Mall South, 5th Floor
P.O. Box 95046
Lincoln, Nebraska, 68509-5046
Phone (402) 471-2571
Fax (402) 471-2814 or (402) 471-2374
TSR USER 800-833-7252 (TTY)
Web Address <http://www.lcc.nebraska.gov/>

RECEIPT

From: Hannah Yates

To: Columbus City Clerk

Re: Balaji Petroleum, LLC

DBA: Dual Stop Columbus

License #: D-125663

Please complete this page immediately and fax or email to us acknowledging you have received the application. Signatures are not required.

Kelli Keyes
Clerk's Name (Acknowledgement of receipt of the application)

5-12-23
Date Received

Kim Lowe
Commissioner

Bruce Bailey
Chairman

Harry Hoch
Commissioner



COLUMBUS POLICE DEPARTMENT

2330 14th Street • Columbus, Nebraska 68601 • Phone (402) 564-3201 • Fax (402) 562-7325

TO: HONORABLE MAYOR AND CITY COUNCIL
CITY OF COLUMBUS

FROM: CHARLES L. SHERER, CHIEF OF POLICE 

DATE: MAY 18TH, 2023

SUBJECT: BALAJI PETROLEUM, LLC
DBA: DUAL STOP COLUMBUS
LIQUOR LICENSE APPLICATION
3417 14TH STREET
COLUMBUS, NEBRASKA

MANAGER: NIRAJ PATEL

- A. The adequacy of existing law enforcement resources and services in the area:
There are adequate law enforcement resources and services in the area.
- B. Existing motor vehicle and pedestrian traffic flow in the vicinity of the proposed licensed premises, potential traffic and parking problems, and the proximity and availability of on-street and off-street parking:
There is moderate motor vehicle and some pedestrian traffic at this location. There seems to be no traffic or parking problems. There is adequate parking available.
- C. Zoning restrictions and the local governing body's zoning and land-use policies:
The area is zoned for business.
- D. Sanitation or sanitary conditions on or about the proposed licensed premises:
Sanitation or sanitary conditions are in order.
- E. The existence of a citizen's protest or opposition to the application:
There is no known citizen protest or opposition to the application.

- F. The existing population and projected growth within the jurisdiction of the local governing body and within the area to be served:

There is normal projected population growth within the jurisdiction of the local governing body and within the area to be served.

- G. The existing liquor licenses, the class of each such license, and the distance and times of travel between establishments issued such licenses:

The existing liquor licenses in the area include one to the north, Husker House (Class C) an approximate 6 minute walk. One to the west, Casey's (Class D) an approximate 7 minute walk. It should be noted that the current site for Dual Stop Columbus use to be Sam's General Store (Class D).

- H. Whether the proposed license would be compatible with the neighborhood or community where the proposed premises are located:

The proposed license is compatible with this area.

- I. Whether the type of business or activity proposed to be operated or presently operated in conjunction with the proposed license is and will be consistent with the public interest as declared in section 53-101.01:

The type of business and activity proposed will be consistent with public intent.

- J. Whether the applicant can ensure that all alcoholic beverages, including beer and wine, will be handled by persons in accordance with section 53.102:

There is no evidence shown that the applicant will not ensure that all alcoholic beverages will be handled by persons in accordance with section 53-102.

- K. Whether the applicant has taken every reasonable precaution to protect against the possibility of shoplifting of alcoholic liquor, which alcoholic liquor shall be displayed and kept in and sold from an area which is reasonably secured:

There is no evidence that the applicant will not take every reasonable precaution to prevent shoplifting and the area is reasonably secured.

- L. Whether the applicant is fit, willing, and able to properly provide the service proposed in conformance with all provisions and requirements of, and rules and regulations adopted and promulgated pursuant to the act:

There is no evidence showing that the applicant is not fit, willing, and able to properly provide the service proposed in conformance with all provisions and

requirements of, and rules and regulations adopted and promulgated pursuant to the act.

- M. Whether the applicant has demonstrated that the type of management and control exercised over the licensed premises will be sufficient to ensure that the licensee can conform to all the provisions and requirements of, and rules and regulations adopted promulgated pursuant to the act:

There is no evidence shown that the applicant will not demonstrate that the type of management and control over the licensed premises and will ensure that the licensee can conform to all the provisions and requirements of, and rules and regulations adopted promulgated pursuant to the act.

- N. The background information of the applicant established by information contained in the public records of the commission and investigations conducted by law enforcement agencies:

The background information does not reveal any felony arrests or violations of the applicant.

- O. Past evidence of discrimination involving the applicant as evidenced by findings of fact before any administrative board or agency of the local governing body, and other governmental board or agency of the local governing body, and other governmental unit, or any court of law:

There is no evidence of discrimination involving the applicant.

- P. Whether the applicant or the applicant's representatives suppressed any fact or provided any inaccurate information to the commission or local governing body or the employees of the commission or local governing body in regards to the license application or liquor investigations. The applicant shall be required to cooperate in providing a full disclosure to the investigation agents of the local governing body.

The applicant and applicant's representatives have not suppressed or provided inaccurate information to the local governing body.

- Q. Proximity of and impact on schools, hospitals, libraries, parks, and other public institutions:

There will be no impact on local schools, libraries, parks, and other public institutions:

- R. Whether activities proposed to be conducted on the licensed premises or in adjacent related outdoor areas will create unreasonable noise or disturbance:

Activities will not create unreasonable noise.

- S. Compliance with state laws, liquor rules and regulations and municipal ordinances and regulations and whether or not the applicant has ever forfeited bond to appear in court to answer charges of having committed a felony or charges of having violated any law or ordinance enacted in the interest of good morals and decency or has been convicted of violating or has forfeited bond to appear in court and answer charges for violating any law or ordinance relating to alcoholic liquor:

There is no evidence to show that the applicant has forfeited bond to appear in court for violating any liquor law or ordinance relating to alcoholic liquor.

- T. The recommendation of the police department or any other law enforcement agency:

The Columbus Police Department recommends approval of the Dual Stop Columbus liquor license

LIQUOR APPLICATION REPORTS
ENGINEER'S REPORT

DATE: May 15, 2023

DUE DATE: May 31, 2023

Applicant Balaji Petroleum, LLC dba Dual Stop Columbus

Address 3417 14th Street, Columbus, NE 68601

Legal Description LOT 7 BLK 8 HIGHLAND PARK COLUMBUS

IS (x) IS NOT () WITHIN THE CORPORATE LIMITS OF THE MUNICIPALITY

**IF NOT, DO NOT PROCEED - NOTIFY THE MUNICIPAL CLERK'S OFFICE
AND RETURN THIS FORM**

Requested License or Action: Class D

Existing Zoning: B-2

Existing Land Use: Commercial

Adjacent Land Use and Zoning:

North: B-2

South: B-2

East: B-1

West: B-2

General Neighborhood/Area Land Uses: Commercial, single family residential

Designation of Adjacent Street (Local, Collector, Minor or Major Arterial, Expressway): : Minor Arterial (Howard Blvd. & 14th Street)

Street Width and Profile: North: 33' wide, 2 lanes one way west (14th Street) &
South: 42' wide 3 lanes one way east (Howard Blvd.)

Speed Limit: 35 mph (both)

Average Daily Traffic Count: 9,500 ADT(2016)



Richard J. Bogus, P.E.
City Engineer

APPLICATION FOR LIQUOR LICENSE CHECKLIST RETAIL

NEBRASKA LIQUOR CONTROL COMMISSION
301 CENTENNIAL MALL SOUTH
PO BOX 95046
LINCOLN, NE 68509-5046
PHONE: (402) 471-2571
FAX: (402) 471-2814
EMAIL: lcc.frontdesk@nebraska.gov
WEBSITE: www.lcc.nebraska.gov

License Class: D

License Number:
125663



Office Use Only
NEW/REPLACING 122074 TOP Yes No
Hot List Yes No 23000-01445-location Initial: IN

PLEASE READ CAREFULLY

See directions on the next page. Provide all the items requested. Failure to provide any item will cause this application to be returned or placed on hold. All documents must be legible. Any false statement or omission may result in the denial, suspension, cancellation or revocation of your license. If your operation depends on receiving a liquor license, the Nebraska Liquor Control Commission cautions you that if you purchase, remodel, start construction, spend or commit money that you do so at your own risk. Prior to submitting your application review the application carefully to ensure that all sections are complete, and that any omissions or errors have not been made. You may want to check with the city/village or county clerk, where you are making application, to see if any additional requirements must be met before submitting application to the Nebraska Liquor Control Commission.

APPLICANT NAME BALAJI PETROLEUM, LLC

TRADE (DBA) NAME Dual Stop Columbus- 14th street

PREVIOUS TRADE (DBA) NAME n/a

CONTACT NAME AND PHONE NUMBER Maulin Patel, (712) 490-1210

CONTACT EMAIL ADDRESS maulinpatel93@gmail.com

Office use only PAYMENT TYPE <u>Passport</u> AMOUNT <u>3400.-</u> RCPT RECEIVED: <u>4/26/23</u> DATE DEPOSITED _____	 2300004687
--	----------------

DIRECTIONS

Each item must be included with your application

1. Application fee of \$400 (nonrefundable), please pay online thru our PAYPORT system or enclose payment made payable to the Nebraska Liquor Control Commission
2. Enclose the appropriate application forms
 - Individual License (Form 104)
 - Partnership License (Form 105)
 - Corporate License (Form 101 & Form 103)
 - Limited Liability Company (LLC) (Form 102 & Form 103)Corporation or Limited Liability Company (LLC) must be active with the Nebraska Secretary of State
3. For citizenship enclose U.S. birth certificate; U.S. passport or naturalization paper
 - a. For residency enclose proof of registered voter in Nebraska
 - b. If permanent resident include Employment Authorization Card or Permanent Resident Card
 - c. See Applicant Guidelines for further assistance
4. Form 147 - Fingerprints are required for each person as defined in new application guide, found on our website under "Licensing Tab" in "Guidelines/Brochures".
5. If purchasing an already licensed business; include Form 125—Temporary Operating Permit (TOP)
 - a. Form 125 must be signed by the seller (current licensee) and the buyer (applicant)
 - b. Provide a copy of the business purchase agreement from the seller (current licensee sells "the business currently licensed" to applicant)
 - c. Provide a copy of alcohol inventory being purchased (must include quantity, brand name and container size)
 - d. Enclose a list of the assets being purchased (furniture, fixtures and equipment)
6. If building is owned or being purchased send a copy of the deed or purchase agreement in the name of the applicant.
7. If building is being leased, send a copy of signed lease in the name of the applicant. Lease term must run through the license year being applied for.
8. Submit a copy of your business plan.

**CLASS OF LICENSE FOR WHICH APPLICATION IS MADE AND FEES
CHECK DESIRED CLASS**

RETAIL LICENSE(S) Application Fee \$400 (nonrefundable)
CLASS C LICENSE TERM IS FROM NOVEMBER 1 – OCTOBER 31
ALL OTHER CLASSES TERM IS MAY 1 – APRIL 30

- A BEER, ON SALE ONLY
 - B BEER, OFF SALE ONLY**
 - C BEER, WINE, DISTILLED SPIRITS, ON AND OFF SALE**
Do you intend to sale cocktails to go as allowed under Neb Rev. Statute 53-123.04(4) YES NO
 - D BEER, WINE, DISTILLED SPIRITS, OFF SALE ONLY**
 - F BOTTLE CLUB,
 - I BEER, WINE, DISTILLED SPIRITS, ON SALE ONLY
Do you intend to sale cocktails to go as allowed under Neb Rev. Statute 53-123.04(5) YES NO
 - J LIMITED ALCOHOLIC LIQUOR, OFF SALE – MUST INCLUDE SUPPLEMENTAL FORM 120
 - AB BEER, ON AND OFF SALE
 - AD BEER ON SALE ONLY, BEER, WINE, DISTILLED SPIRITS OFF SALE
 - IB BEER, WINE, DISTILLED SPIRITS ON SALE, BEER OFF SALE ONLY
 - Class K Catering endorsement (Submit Form 106) – Catering license (K) expires same as underlying retail license
 - Class G Growler endorsement (Submit Form 165) – Class C licenses only
- **Class B, Class C, Class D license do you intend to allow drive through services under Neb Rev. Statute 53-178.01(2) YES NO

ADDITIONAL FEES WILL BE ASSESSED AT THE CITY/VILLAGE OR COUNTY LEVEL WHEN THE LICENSE IS ISSUED

CHECK TYPE OF LICENSE FOR WHICH YOU ARE APPLYING

- Individual License (requires insert FORM 104)
- Partnership License (requires insert FORM 105)
- Corporate License (requires FORM 101 & FORM 103)
- Limited Liability Company (LLC) (requires FORM 102 & FORM 103)

NAME OF ATTORNEY OR FIRM ASSISTING WITH APPLICATION (if applicable)

Name Margaret A. Rossiter Phone Number (402) 978-5255

Firm Name Fraser Stryker PC LLO

Email address mrossiter@fraserstryker.com

Should we contact you with any questions on the application? YES NO

PREMISES INFORMATION

Trade Name (doing business as) Dual Stop Columbus- ~~14th st.~~

Street Address 3417 14th Street

City Columbus County Platte - 10 Zip Code 68601-4711

Premises Telephone number (402) 362-2388

Business e-mail address maulinpatel93@gmail.com

Is this location inside the city/village corporate limits YES NO

MAILING ADDRESS (where you want to receive mail from the Commission)

Check if same as premises

Name same as Premises

Street Address _____

City _____ State _____ Zip Code _____

DESCRIPTION AND DIAGRAM OF THE AREA TO BE LICENSED

IN THE SPACE PROVIDED BELOW DRAW OR ATTACH A DIAGRAM OF THE AREA TO BE LICENSED
DO NOT SEND BLUEPRINTS, ARCHITECT OR CONSTRUCTION DRAWINGS
PROVIDE LENGTH X WIDTH IN FEET (NOT SQUARE FOOTAGE)
INDICATE THE DIRECTION OF NORTH

Building length 30 x width 49 in feet

Is there a basement? Yes No If yes, length _____ x width _____ in feet

Is there an outdoor area? Yes No If yes, length _____ x width _____ in feet+

*If including an outdoor area permanent fencing is required. Please contact the local governing body for other requirements regarding fencing

Number of floors of the building 1

PROVIDE DIAGRAM OF AREA TO BE LICENSED BELOW OR ATTACH SEPARATE SHEET

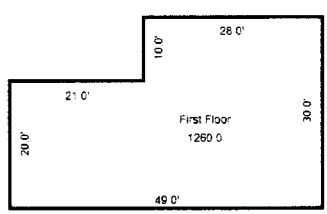

APPLICANT INFORMATION

1. READ CAREFULLY. ANSWER COMPLETELY AND ACCURATELY §53-125(5)

Has anyone who is a party to this application, or their spouse, **EVER** been convicted of or plead guilty to any charge. Charge means any charge alleging a felony, misdemeanor, violation of a federal or state law; a violation of a local law, ordinance or resolution. List the nature of the charge, where the charge occurred and the year and month of the conviction or plea. Also list any charges pending at the time of this application. If more than one party, please list charges by each individual's name.

Include traffic violations. Commission must be notified of any arrests and/or convictions that may occur after the date of signing this application.

YES NO If yes, please explain below or attach a separate page

Name of Applicant	Date of Conviction (mm/yyyy)	Where Convicted (city & state)	Description of Charge	Disposition
Maulin Patel	November 2016	Omaha, NE	Speeding	Plea of con contest, fines paid, file since purged
Maulin Patel	June 2017	Omaha, NE	Speeding	Guilty, paid fine
Maulin Patel	March 2018	Omaha, NE	no registration	Guilty, paid fine
Maulin Patel	June 2018	Omaha, NE	speeding	Guilty, paid fine
Maulin Patel	November 2019	Omaha, NE	unlawful occupation	Guilty, paid fine
Continued on next page				

2. Was this premise licensed as liquor licensed business within the last two (2) years?

YES NO

If yes, provide business name and license number Sam's General Store #122074

3. Are you buying the business of a current retail liquor license?

YES NO

If yes, give name of business and liquor license number Sam's General Store #122074

4. Are you filing a temporary operating permit (TOP) to operate during the application process?

YES NO

If yes

a) Attach temporary operating permit (TOP) (Form 125)

a) Submit a copy of the business purchase agreement _____

b) Include a list of alcohol being purchased, list the name brand, container size and how many _____

c) Submit a list of the furniture, fixtures and equipment _____

Name of Applicant	Date of Conviction	Where Convicted	Description of Charge	Disposition
Maulin Patel	February 2019	Omaha, NE	DWI	Guilty- Paid fine
Maulin Patel			Speeding	

5. Are you borrowing any money from any source, include family or friends, to establish and/or operate the business?

_____ YES _____ NO

If yes, list the lender(s) _____

6. Will any person or entity, other than applicant, be entitled to a share of the profits of this business?

_____ YES _____ NO

If yes, explain. (all involved persons must be disclosed on application)

No silent partners 019.01E Silent Partners; Profit Sharing: No licensee or partner, principal, agent or employee of any Retail Liquor License shall permit any other person not licensed or included as a partner, principal, or stockholder of any Retail Liquor License to participate in the sharing of profits or liabilities arising from any Retail Liquor License. (53-1,100)

7. Will any of the furniture, fixtures and equipment to be used in this business be owned by others?

_____ YES _____ NO

If yes, list such item(s) and the owner. _____

8. Is premises to be licensed within 150 feet of a church, school, hospital, home for indigent persons or for veterans, their wives, and children; or within 300 feet of a college or university campus?

_____ YES _____ NO

If yes, provide name and address of such institution and where it is located in relation to the premises (Nebraska Revised Statute 53-177(1) **AND PROVIDE FORM 134 – CHURCH OR FORM 135 – CAMPUS AND LETTER OF SUPPORT FROM CHURCH OR CAMPUS**)

9. Is anyone listed on this application a law enforcement officer? If yes, list the person, the law enforcement agency involved and the person's exact duties. (Nebraska Revised Statute 53-125(15))

_____ YES _____ NO

10. List the primary bank and/or financial institution (branch if applicable) to be utilized by the business.

a) List the individual(s) who are authorized to write checks and/or withdrawals on accounts at this institution.

First National Bank- Omaha- Maulin Patel, Lakhwinder Singh

11. List all past and present liquor licenses held in Nebraska or any other state by any person named in this application. Include license holder name, location of license and license number. Also list reason for termination of any license(s) previously held.

Please see next page.

Maulin Patel Current Liquor Licenses:

1. Mason Enterprises, Inc. (#123489) in York, Nebraska.
2. Mason Enterprises 2 Inc. (#124506) in York, Nebraska.
3. Shakti Fuels (#110675) in La Vista, Nebraska.
4. N.K. Corporation (#119766) in La Vista, Nebraska.
5. Saga Properties LLC (#124984) in Omaha, Nebraska.
6. Saga Properties Fremont LLC (#125074) in Fremont, Nebraska.

Lakhwinder Singh Current Liquor Licenses:

1. Firewater Grille (#123112) in Omaha, Nebraska.
2. BP Gas Station (#1A-1148072) in Rockford, Illinois.
3. Red Duck C Store (#OP01777) in Ogden, UT.
4. Mason Enterprises 2 Inc. (#124506) in York, Nebraska.

12. List the alcohol related training and/or experience (when and where) of the person(s) making application. Those persons required are listed as followed:

- Individual: Applicant and spouse; spouse is exempt if they filed Form 116 – Affidavit of Non-Participation.
- Partnership: All partners and spouses, spouses are exempt if they filed Form 116 – Affidavit of Non-Participation.
- Limited Liability Company: All member of LLC, Manager and all spouses; spouses are exempt if they filed Form 116 – Affidavit of Non-Participation.
- Corporation: President, Stockholders holding 25% or more of shares, Manager and all spouses; spouses are exempt if they filed Form 116 – Affidavit of Non-Participation.

NLCC certified training program completed

Applicant Name	Date (mm/yyyy)	Name of program (attach copy of course completion certificate)
Lakhwinder Singh		Alcohol off premises management certificate

Experience

Applicant Name/Job Title	Date of Employment	Name & Location of Business
Lakhwinder Singh- Manager	presently employed	Red Duck C Store, Ogden, UT
Lakhwinder Singh- President	presently employed	Firewater Grille, Omaha, NE
Maulin Patel- Owner, President	presently employed	Dual Stop, Food & Fuel R Us, Kirk's Komer- all in York and Omaha, NE

13. If the property is owned, submit a copy of the deed or proof of ownership. If leased, submit a copy of the lease covering the entire license year.

Documents must be in the name of applicant as owner or lessee

X Lease expiration date 4/30/2053

 Deed

 Purchase Agreement

14. When do you intend to open for business? Approx 06/01/2023

15. What will be the main nature of business? Convenience Store and Gas Station

16. What are the anticipated hours of operation? 6am-11pm daily

17. List the principal residence(s) for the past 10 years for **ALL** persons required to sign, including spouses.

RESIDENCES FOR THE PAST 10 YEARS					
APPLICANT CITY & STATE	YEAR		SPOUSE CITY & STATE	YEAR	
	FROM	TO		FROM	TO
Maulin- Patel Omaha, NE	2012	present	Mexa Patel- Anand, Gujarat, India	2012	2022
			Mexa Patel- Omaha, NE	2022	present
Lakhwinder Singh, South Jordan, UT	2012	present	Lakhwinder Kaur- South Jordan, UT	2012	present

If necessary, attach a separate sheet

**PERSONAL OATH AND CONSENT OF INVESTIGATION
SIGNATURE PAGE – PLEASE READ CAREFULLY**

The undersigned applicant(s) hereby consent(s) to an investigation of his/her background and release present and future records of every kind and description including police records, tax records (State and Federal), and bank or lending institution records, and said applicant(s) and spouse(s) waive(s) any right or causes of action that said applicant(s) or spouse(s) may have against the Nebraska Liquor Control Commission, the Nebraska State Patrol, and any other individual disclosing or releasing said information. Any documents or records for the proposed business or for any partner or stockholder that are needed in furtherance of the application investigation of any other investigation shall be supplied immediately upon demand to the Nebraska Liquor Control Commission or the Nebraska State Patrol. The undersigned understand and acknowledge that any license issued, based on the information submitted in this application, is subject to cancellation if the information contained herein is incomplete, inaccurate or fraudulent.

Individual applicants agree to supervise in person the management and operation of the business and that they will operate the business authorized by the license for themselves and not as an agent for any other person or entity. Corporate applicants agree the approved manager will superintend in person the management and operation of the business. Partnership applicants agree one partner shall superintend the management and operation of the business. All applicants agree to operate the licensed business within all applicable laws, rules, regulations, and ordinances and to cooperate fully with any authorized agent of the Nebraska Liquor Control Commission.

Applicant Notification and Record Challenge: Your fingerprints will be used to check the criminal history records of the FBI. You have the opportunity to complete or challenge the accuracy of the information contained in FBI identification record. The procedures for obtaining a change, correction, or updating an FBI identification record are set forth in Title 28, CFR, 16.34.

**Must be signed by all applicant(s) and spouse(s) owning more than 25%
(YOU MAY NEED TO PRINT MULTIPLE SIGNATURE PAGES)**

maulin patel

Signature of APPLICANT

Maulin Patel

Printed Name of APPLICANT

Signature of APPLICANT

Printed Name of APPLICANT

Mexa patel

Signature of SPOUSE

Mexa Patel

Printed Name of SPOUSE

Signature of SPOUSE

Printed Name of SPOUSE

PERSONAL OATH AND CONSENT OF INVESTIGATION
SIGNATURE PAGE – PLEASE READ CAREFULLY

The undersigned applicant(s) hereby consent(s) to an investigation of his/her background and release present and future records of every kind and description including police records, tax records (State and Federal), and bank or lending institution records, and said applicant(s) and spouse(s) waive(s) any right or causes of action that said applicant(s) or spouse(s) may have against the Nebraska Liquor Control Commission, the Nebraska State Patrol, and any other individual disclosing or releasing said information. Any documents or records for the proposed business or for any partner or stockholder that are needed in furtherance of the application investigation of any other investigation shall be supplied immediately upon demand to the Nebraska Liquor Control Commission or the Nebraska State Patrol. The undersigned understand and acknowledge that any license issued, based on the information submitted in this application, is subject to cancellation if the information contained herein is incomplete, inaccurate or fraudulent.

Individual applicants agree to supervise in person the management and operation of the business and that they will operate the business authorized by the license for themselves and not as an agent for any other person or entity. Corporate applicants agree the approved manager will superintend in person the management and operation of the business. Partnership applicants agree one partner shall superintend the management and operation of the business. All applicants agree to operate the licensed business within all applicable laws, rules, regulations, and ordinances and to cooperate fully with any authorized agent of the Nebraska Liquor Control Commission.

Applicant Notification and Record Challenge: Your fingerprints will be used to check the criminal history records of the FBI. You have the opportunity to complete or challenge the accuracy of the information contained in FBI identification record. The procedures for obtaining a change, correction, or updating an FBI identification record are set forth in Title 28, CFR, 16.34.

Must be signed by all applicant(s) and spouse(s) owning more than 25%
(YOU MAY NEED TO PRINT MULTIPLE SIGNATURE PAGES)

Lakhwinder Singh
Signature of **APPLICANT**

Lakhwinder Singh
Printed Name of **APPLICANT**

Signature of **APPLICANT**

Printed Name of **APPLICANT**

Lakhwinder Kaur
Signature of **SPOUSE**

Lakhwinder Kaur
Printed Name of **SPOUSE**

Signature of **SPOUSE**

Printed Name of **SPOUSE**

PERSONAL OATH AND CONSENT OF INVESTIGATION
SIGNATURE PAGE - PLEASE READ CAREFULLY

The undersigned applicant(s) hereby consent(s) to an investigation of his/her background and release present and future records of every kind and description including police records, tax records (State and Federal), and bank or lending institution records, and said applicant(s) and spouse(s) waive(s) any right or causes of action that said applicant(s) or spouse(s) may have against the Nebraska Liquor Control Commission, the Nebraska State Patrol, and any other individual disclosing or releasing said information. Any documents or records for the proposed business or for any partner or stockholder that are needed in furtherance of the application investigation of any other investigation shall be supplied immediately upon demand to the Nebraska Liquor Control Commission or the Nebraska State Patrol. The undersigned understand and acknowledge that any license issued, based on the information submitted in this application, is subject to cancellation if the information contained herein is incomplete, inaccurate or fraudulent.

Applicant Notification and Record Challenge: Your fingerprints will be used to check the criminal history records of the FBI. You have the opportunity to complete or challenge the accuracy of the information contained in FBI identification record. The procedures for obtaining a change, correction, or updating an FBI identification record are set forth in Title 28, CFR, 16.34.

Must be signed by applicant and spouse.

Niraj Patel

Signature of **APPLICANT**

Niraj Patel

Printed Name of **APPLICANT**

Jignasu patel

Signature of **SPOUSE**

Jignasu Patel

Printed Name of **SPOUSE**

Nebraska Secretary of State

BALAJI PETROLEUM, LLC

Tue May 2 08:13:42 2023

SOS Account Number

2302084756

Status

Active

Principal Office Address

No address on file

Registered Agent and Office Address

MARGARET A. ROSSITER

409 SOUTH 17TH STREET

500 ENERGY PLAZA

OMAHA, NE 68102

Designated Office Address

10708 M STREET

OMAHA, NE 68127

Nature of Business

Not Available

Entity Type

Domestic LLC

Qualifying State: NE

Date Filed

Feb 17 2023

Next Report Due Date

Jan 01 2025

Filed Documents

Filed documents for BALAJI PETROLEUM, LLC may be available for purchase and downloading by selecting the Purchase Now button. Your Nebraska.gov account will be charged the indicated amount for each item you view. If no Purchase Now button appears, please contact Secretary of State's office to request document(s).

Document	Date Filed	Price	
Certificate of Organization	Feb 17 2023	\$0.45 = 1 page(s) @ \$0.45 per page	Purchase Now

Good Standing Documents

- If you need your Certificate of Good Standing Apostilled or Authenticated for use in another country, you must contact the Nebraska Secretary of State's office directly for information and instructions. Documents obtained from this site cannot be Apostilled or Authenticated.

Online Certificate of Good Standing with Electronic Validation

\$6.50

This certificate is available for immediate viewing/printing from your desktop. A Verification ID is provided on the certificate to validate authenticity online at the Secretary of State's website.

Purchase Now

Certificate of Good Standing - USPS Mail Delivery

\$10.00

This is a paper certificate mailed to you from the Secretary of State's office within 2-3 business days.

[Continue to Order](#)

[↑ Back to Top](#)

LIMITED LIABILITY COMPANY (LLC)

NEBRASKA LIQUOR CONTROL COMMISSION
301 CENTENNIAL MALL SOUTH
PO BOX 95046
LINCOLN, NE 68509-5046
PHONE: (402) 471-2571
FAX: (402) 471-2814
EMAIL: lcc.frontdesk@nebraska.gov
WEBSITE: www.lcc.nebraska.gov

License
Class: _____

License Number: _____

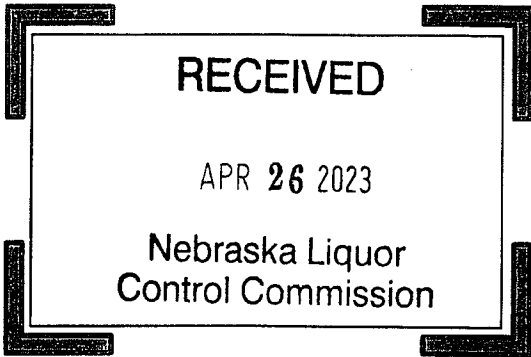

INSTRUCTIONS

1. All members and spouses must be listed
2. Managing/Contact member and all members holding over 25 % shares of stock and their spouse (if applicable) must sign the signature page of the application
3. Managing/Contact member and all members holding over 25% interest and their spouses must submit fingerprints. See Form 147 for further information
4. Attach copy of Articles of Organization

Name of Limited Liability Company that will hold license as listed on the Articles of Organization

Balaji Petroleum, LLC

Name of Registered Agent: Margaret A. Rossiter

LLC Address: 3417 14th Street

City: Coumbus State: Ne Zip Code: 68601

LLC Phone Number: (402) 362-2388 LLC Fax Number: _____

Name of Managing/Contact Member

Name and information of contact member must be listed on following page

Last Name: Patel First Name: Maulin MI: N.

Home Address: 10708 M Street City: Omaha

State: NE Zip Code: 68128-1919 Home Phone Number: (712) 490-1210

maulin patel

Signature of Managing/Contact Member

List names of all members and their spouses (even if a spousal affidavit has been submitted)

Last Name: Patel First Name: Maulin MI: _____

Spouse Full Name (indicate N/A if single): Mexa Patel

Percentage of member ownership 50.00%

Last Name: Singh First Name: Lakhwinder MI: _____

Spouse Full Name (indicate N/A if single): Lakhwinder Kaur

Percentage of member ownership 50.00%

Last Name: _____ First Name: _____ MI: _____

Social Security Number: _____ Date of Birth: _____

Spouse Full Name (indicate N/A if single): _____

Spouse Social Security Number: _____ Date of Birth: _____

Percentage of member ownership _____

Last Name: _____ First Name: _____ MI: _____

Social Security Number: _____ Date of Birth: _____

Spouse Full Name (indicate N/A if single): _____

Spouse Social Security Number: _____ Date of Birth: _____

Percentage of member ownership _____

List names of all members and their spouses (even if a spousal affidavit has been submitted)

Last Name: _____ First Name: _____ MI: _____

Social Security Number: _____ Date of Birth: _____

Spouse Full Name (indicate N/A if single): _____

Spouse Social Security Number: _____ Date of Birth: _____

Percentage of member ownership _____

Last Name: _____ First Name: _____ MI: _____

Social Security Number: _____ Date of Birth: _____

Spouse Full Name (indicate N/A if single): _____

Spouse Social Security Number: _____ Date of Birth: _____

Percentage of member ownership _____

Last Name: _____ First Name: _____ MI: _____

Social Security Number: _____ Date of Birth: _____

Spouse Full Name (indicate N/A if single): _____

Spouse Social Security Number: _____ Date of Birth: _____

Percentage of member ownership _____

Last Name: _____ First Name: _____ MI: _____

Social Security Number: _____ Date of Birth: _____

Spouse Full Name (indicate N/A if single): _____

Spouse Social Security Number: _____ Date of Birth: _____

Percentage of member ownership _____

Is the applying Limited Liability Company owned 100% by another corporation/LLC?

YES NO

If yes, Form 185 is required

Indicate the company's tax year with the IRS (Example January through December)

Starting Date: January Ending Date: December

Is this a Non Profit Corporation?

YES NO

If yes, provide the Federal ID #. _____

**CERTIFICATE OF ORGANIZATION
OF
BALAJI PETROLEUM, LLC**

The undersigned, desiring to form a limited liability company (the "Company") under the Nebraska Uniform Limited Liability Company Act, NEB. REV. STAT. § 21-101 *et seq*, (the "Act"), do hereby state as follows:

1. **Name**. The name of the Company shall be Balaji Petroleum, LLC.
2. **Designated Office**. The designated office of the Company is 10708 M Street, Omaha, Nebraska 68127.
3. **Purpose**. The Company may conduct any and all business as allowed by law.
4. **Registered Agent and Office**. The name and address of the registered agent of the Company is Margaret A. Rossiter, Fraser Stryker PC LLO, 409 South 17th Street, 500 Energy Plaza, Omaha, Nebraska 68102.

EXECUTED by the Organizer on the 15th day of February, 2023

By: Margaret A. Rossiter
Margaret A. Rossiter, Organizer

7.B.1. Application of Dual Stop Columbus for Niraj R. Patel as manager in conjunction with liquor license.

MANAGER APPLICATION FORM 103

NEBRASKA LIQUOR CONTROL COMMISSION
301 CENTENNIAL MALL SOUTH
PO BOX 95046
LINCOLN, NE 68509-5046
PHONE: (402) 471-2571
FAX: (402) 471-2814
EMAIL: lcc.frontdesk@nebraska.gov
WEBSITE: www.lcc.nebraska.gov

License
Class: _____

License Number: _____

RECEIVED

APR. 26 2023

Nebraska Liquor
Control Commission

MANAGER MUST:

- Be at least 21-years of age
- Complete all sections of the application.
- Form must be signed by a **member or corporate officer**
- Include Form 147 –Fingerprints are required
- Provide a copy of one of the following: US birth certificate, US Passport or naturalization papers
- Be a resident of the state of Nebraska and be a registered voter in the State of Nebraska,
- Spouse who **will** participate in the business, the **spouse must meet the same requirements as the manager applicant:**

Spouse who **will not** participate in the business

- Complete the Spousal Affidavit of Non Participation (Form 116). **Be sure to complete both halves of this form.**

CORPORATION/LLC INFORMATION

Name of Corporation/LLC: BALAJI PETROLEUM, LLC

PREMISES INFORMATION

Premises Trade Name/DBA: Dual Stop Columbus- 14th street

Premises Street Address: 3417 14th Street

City: Columbus County: Platte Zip Code: 68601

Premises Phone Number: (402) 362-2388

Premises Email address: maulinpatel93@gmail.com

maulin patel

SIGNATURE REQUIRED BY CORPORATE OFFICER / MANAGING MEMBER

The individual whose name is listed as a corporate officer or managing member as reported or listed with the Commission.

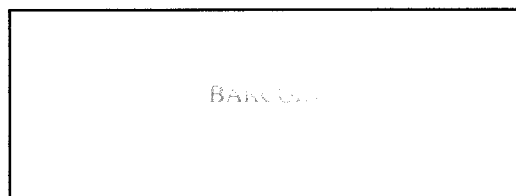

MANAGER INFORMATION

Last Name: Patel First Name: Niraj MI: _____

Home Address: 10708 M. Street

City: Omaha County: Douglas Zip Code: 68127

Home Phone Number: (712) 490-8054

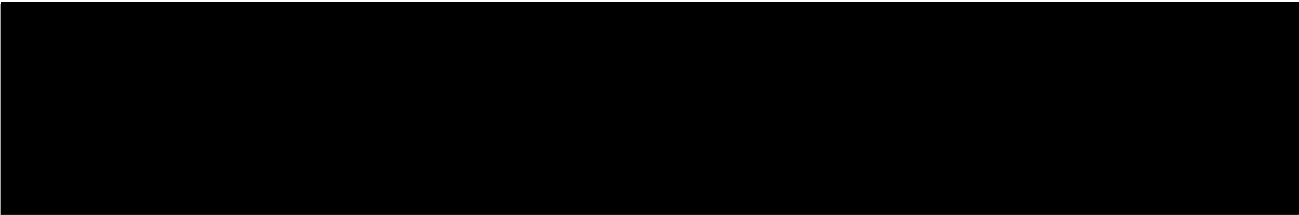

Email address: mrossiter@fslf.com

Are you married? If yes, complete spouse's information (Even if a spousal affidavit has been submitted)

YES NO

Spouse's information

Spouses Last Name: Patel First Name: Jignasu MI: _____

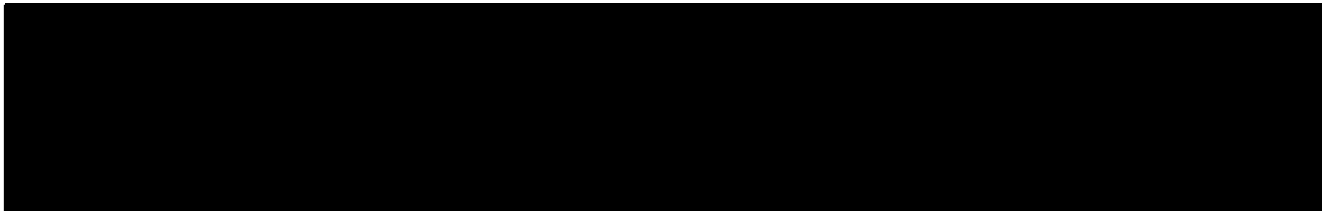

APPLICANT & SPOUSE MUST LIST RESIDENCE(S) FOR THE PAST TEN (10) YEARS
APPLICANT SPOUSE

CITY & STATE	YEAR FROM	YEAR TO	CITY & STATE	YEAR FROM	YEAR TO

MANAGER'S LAST TWO EMPLOYERS

YEAR FROM TO		NAME OF EMPLOYER	NAME OF SUPERVISOR	TELEPHONE NUMBER
2016	present	Lucky Charm Hospitality	Maulin Patel	712-490-1210
2010	2015	Shakti Petroleum	Mihir Patel	

1. READ CAREFULLY. ANSWER COMPLETELY AND ACCURATELY.

Must be completed by both applicant and spouse, unless spouse has filed an affidavit of non-participation.

Has anyone who is a party to this application, or their spouse, EVER been convicted of or plead guilty to any charge. Charge means any charge alleging a felony, misdemeanor, violation of a federal or state law; a violation of a local law, ordinance or resolution. List the nature of the charge, where the charge occurred and the year and month of the conviction or plea, **include traffic violations**. Also list any charges pending at the time of this application. If more than one party, please list charges by each individual's name. Commission must be notified of any arrests and/or convictions that may occur after the date of signing this application.

YES NO

If yes, please explain below or attach a separate page.

Name of Applicant	Date of Conviction (mm/yyyy)	Where Convicted (City & State)	Description of Charge	Disposition
Niraj Patel	2/19/2002	Sioux City, NE	DUI	Plea of no contest, fines paid, file since purged
Niraj Patel	8/17/2010	Council Bluffs, IA	Fail to display Resigatration	fines paid
Niraj Patel	12/6/2006	Harrison Co., IA	Speeding	Fines Paid
Niraj Patel	9/20/2007	Harrison Co., IA	Speeding	Fines Paid
Niraj Patel	2/14/2006	Woodbury Co., IA	Speeding	Fines Paid
Niraj Patel	11/21/2001	Woodbury Co., IA	Simple Assault	Fines Paid

2. Have you or your spouse ever been approved or made application for a liquor license in Nebraska or any other state?

YES NO

IF YES, list the name of the premise(s): Fun Unlimited, LLC d/b/a Drinking Well, License Pending NK Corporation, d/b/a Food & Fuels R Us, Nebraska License #119766
 Shakti Fuels, LLC d/b/a Dual Stop Food & Fuel, Nebraska License #110675

3. Do you, as a manager, qualify under Nebraska Liquor Control Act (§53-131.01) and do you intend to supervise, in person, the management of the business?

YES NO

Table for Manager Insert, page 4, question 2:

1. Fun Unlimited, LLC d/b/a Drinking Well
2. NK Corporation, d/b/a Food & Fuels R Us
3. Shakti Fuels, LLC d/b/a Dual Stop Food & Fuel
4. Saga Properties, LLC d/b/a Dual Stop Sorenson
5. Saga Properties Freemont, LLC d/b/a Dual Stop Freemont

4. List the alcohol related training and/or experience (when and where) of the person making application.

*NLCC Training Certificate Issued: 6/3/2019 Name on Certificate: Niraj R. Patel

Applicant Name	Date (mm/yyyy)	Name of program (attach copy of course completion certificate)
Niraj R. Patel	06/2019	RBST State Alcohol Training
Niraj R. Patel	05/2022	RBST State Alcohol Training

*For list of NLCC Certified Training Programs see training

Experience:

Applicant Name / Job Title	Date of Employment:	Name & Location of Business:

5. Have you enclosed form 147 regarding fingerprints?

YES NO

**PERSONAL OATH AND CONSENT OF INVESTIGATION
SIGNATURE PAGE – PLEASE READ CAREFULLY**

The undersigned applicant(s) hereby consent(s) to an investigation of his/her background and release present and future records of every kind and description including police records, tax records (State and Federal), and bank or lending institution records, and said applicant(s) and spouse(s) waive(s) any right or causes of action that said applicant(s) or spouse(s) may have against the Nebraska Liquor Control Commission, the Nebraska State Patrol, and any other individual disclosing or releasing said information. Any documents or records for the proposed business or for any partner or stockholder that are needed in furtherance of the application investigation of any other investigation shall be supplied immediately upon demand to the Nebraska Liquor Control Commission or the Nebraska State Patrol. The undersigned understand and acknowledge that any license issued, based on the information submitted in this application, is subject to cancellation if the information contained herein is incomplete, inaccurate or fraudulent.

Applicant Notification and Record Challenge: Your fingerprints will be used to check the criminal history records of the FBI. You have the opportunity to complete or challenge the accuracy of the information contained in FBI identification record. The procedures for obtaining a change, correction, or updating an FBI identification record are set forth in Title 28, CFR, 16.34.

Must be signed by applicant and spouse.

Niraj Patel

Signature of **APPLICANT**

Niraj Patel

Printed Name of **APPLICANT**

Jignasu patel

Signature of **SPOUSE**

Jignasu Patel

Printed Name of **SPOUSE**

**PRIVACY ACT STATEMENT/
SUBMISSION OF FINGERPRINTS /
PAYMENT OF FEES TO NSP-CID**

NEBRASKA LIQUOR CONTROL COMMISSION
301 CENTENNIAL MALL SOUTH
PO BOX 95046
LINCOLN, NE 68509-5046
PHONE: (402) 471-2571
FAX: (402) 471-2814
Website: www.lcc.nebraska.gov

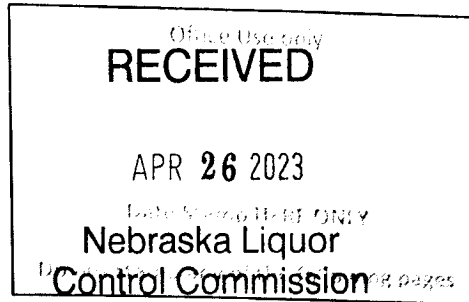

**THIS FORM IS REQUIRED TO BE SIGNED BY EACH PERSON BEING FINGERPRINTED:
DIRECTIONS FOR SUBMITTING FINGERPRINTS AND FEE PAYMENTS:**

- **FAILURE TO FILE FINGERPRINT CARDS AND PAY THE REQUIRED FEE TO THE NEBRASKA STATE PATROL WILL DELAY THE ISSUANCE OF YOUR LIQUOR LICENSE**
- Fee payment of \$45.25 per person **MUST** be made **DIRECTLY** to the Nebraska State Patrol;
It is recommended to make payment through the **NSP PayPort** online system at www.ne.gov/go/nsp
Or a check made payable to **NSP** can be mailed directly to the following address:
*****Please indicate on your payment who the payment is for (the name of the person being fingerprinted) and the payment is for a Liquor License*****
The Nebraska State Patrol – CID Division
4600 Innovation Drive
Lincoln, NE 68521
- Fingerprints taken at NSP LIVESCAN locations will be forwarded to NSP – CID
Applicant(s) will not have cards to include with license application.
- Fingerprints taken at local law enforcement offices may be released to the applicants;
Fingerprint cards should be submitted with the application.

Applicant Notification and Record Challenge: Your fingerprints will be used to check the criminal history records of the FBI. You have the opportunity to complete or challenge the accuracy of the information contained in the FBI identification record. The procedures for obtaining a change, correction, or updating a FBI identification record are set forth in Title 28, CFR, 16.34.

******Please Submit this form with your completed application to the Liquor Control Commission******

Trade Name Dual Stop Columbus- 14th st

Name of Person Being Fingerprinted: Niraj Patel

Date fingerprints were taken: _____

Location where fingerprints were taken: Omaha

How was payment made to NSP?

NSP PAYPORT CASH CHECK SENT TO NSP CK # _____

My fingerprints are already on file with the commission – fingerprints completed for a previous application less than 2 years ago? YES

Niraj Patel
SIGNATURE REQUIRED OF PERSON BEING FINGERPRINTED



[Back to Lookup](#) / [Registrant Detail](#)

Niraj Rasiklal Patel

Political Party
Republican

Precinct
05-01

05/10/2022 2022 Primary Election

05/10/2022 2022 Primary Election



We did not find an absentee or provisional ballot associated with the selected election. This website does not track the status of a traditional ballot voted at the polls. If you voted a traditional ballot at the polls, your ballot has been accepted and counted.

Polling Location

Mockingbird Hills Community Center

📍 10242 Mockingbird Drive Omaha, NE 68127

[View larger map](#)
Plus Midwest Inn

[Rising Cane's
Crisper Fingers](#)

10242 Mockingbird
Dr, Omaha, NE 68127

MOCKING
HILLS

Google Vee Grocery Store

fMap data ©2022

Ballot Styles

126

Districts

Show ▾

© Copyright 2022 - ESSVR, LLC. All rights reserved.

Certificate of Achievement

- for those who serve or sell alcohol in Nebraska

NIRAJ R PATEL

holds a

State Alcohol certificate

Permit # RB-0151682

Permit Expires: 05-19-2025 Amount Paid: \$

 **Responsible Beverage Service Training**
N E B R A S K A 

General	Credential	Number	Earned	Expires
Niraj R Patel 4305 46th st Sioux city IA 51108	STATE ALCOHOL	RB-0151682	05-19-2022	05-19-2025

**SPOUSAL AFFIDAVIT OF
NON PARTICIPATION INSERT**

NEBRASKA LIQUOR CONTROL COMMISSION
301 CENTENNIAL MALL SOUTH
PO BOX 95046
LINCOLN, NE 68509-5046
PHONE: (402) 471-2571
FAX: (402) 471-2814
Website: www.lcc.nebraska.gov

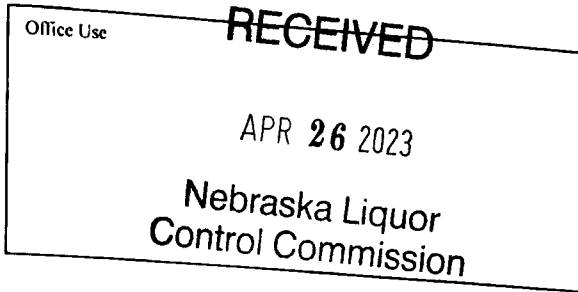

I acknowledge that I am the spouse of a liquor license holder. My signature below confirms that I will not have any interest, directly or indirectly in the operation of the business (§53-125(13)) of the Liquor Control Act. I will not tend bar, make sales, serve patrons, stock shelves, write checks, sign invoices, represent myself as the owner or in any way participate in the day to day operations of this business in any capacity. The penalty guideline for violation of this affidavit is cancellation of the liquor license.

I acknowledge that I am the applicant of the non-participating spouse of the individual signing below. I understand that my spouse and I are responsible for compliance with the conditions set out above. If, it is determined that my spouse has violated (§53-125(13)) the commission may cancel or revoke the liquor license.

NP
Signature of **NON-PARTICIPATING SPOUSE**
Niraj Patel
Print Name

JNP
Signature of **APPLICANT**
Jignasu Patel
Print Name

State of Nebraska, County of DOUGLAS
The foregoing instrument was acknowledged before me
this 11th April, 2023 (date)

State of Nebraska, County of DOUGLAS
The foregoing instrument was acknowledged before me
this 11th April, 2023 (date)

by Niraj Patel
Name of person acknowledged
(Individual signing document)

by Jignasu Patel
Name of person acknowledged
(Individual signing document)

Saumil J Patel
Notary Public Signature

Saumil J Patel
Notary Public Signature

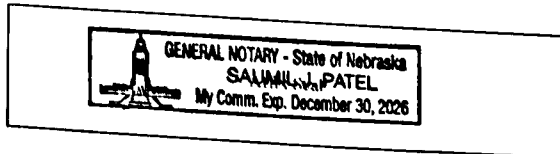
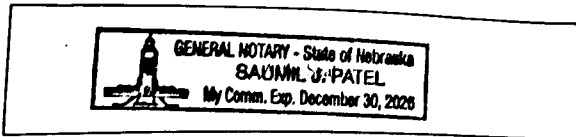

In compliance with the ADA, this spousal affidavit of non participation is available in other formats for persons with disabilities.
A ten day advance period is requested in writing to produce the alternate format.

**PRIVACY ACT STATEMENT/
SUBMISSION OF FINGERPRINTS /
PAYMENT OF FEES TO NSP-CID**

NEBRASKA LIQUOR CONTROL COMMISSION
301 CENTENNIAL MALL SOUTH
PO BOX 95046
LINCOLN, NE 68509-5046
PHONE: (402) 471-2571
FAX: (402) 471-2814
Website: www.lcc.nebraska.gov

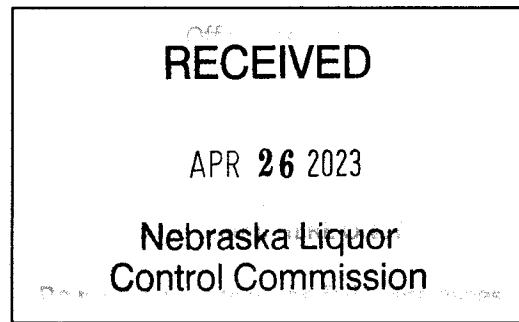

**THIS FORM IS REQUIRED TO BE SIGNED BY EACH PERSON BEING FINGERPRINTED:
DIRECTIONS FOR SUBMITTING FINGERPRINTS AND FEE PAYMENTS:**

- **FAILURE TO FILE FINGERPRINT CARDS AND PAY THE REQUIRED FEE TO THE NEBRASKA STATE PATROL WILL DELAY THE ISSUANCE OF YOUR LIQUOR LICENSE**
- Fee payment of \$45.25 per person **MUST** be made **DIRECTLY** to the Nebraska State Patrol;
It is recommended to make payment through the NSP PayPort online system at www.ne.gov/go/nsp
Or a check made payable to **NSP** can be mailed directly to the following address:
*****Please indicate on your payment who the payment is for (the name of the person being fingerprinted) and the payment is for a Liquor License*****
The Nebraska State Patrol – CID Division
4600 Innovation Drive
Lincoln, NE 68521

- Fingerprints taken at NSP LIVESCAN locations will be forwarded to NSP – CID
Applicant(s) will not have cards to include with license application.
- Fingerprints taken at local law enforcement offices may be released to the applicants;
Fingerprint cards should be submitted with the application.

Applicant Notification and Record Challenge: Your fingerprints will be used to check the criminal history records of the FBI. You have the opportunity to complete or challenge the accuracy of the information contained in the FBI identification record. The procedures for obtaining a change, correction, or updating a FBI identification record are set forth in Title 28, CFR, 16.34.

******Please Submit this form with your completed application to the Liquor Control Commission******

Trade Name Dual Stop Columbus- 14th st

Name of Person Being Fingerprinted: Lakhwinder Singh

Date fingerprints were taken: 08/2021

Location where fingerprints were taken: Salt Lake City, UT

How was payment made to NSP?

NSP PAYPORT CASH CHECK SENT TO NSP CK # _____

My fingerprints are already on file with the commission – fingerprints completed for a previous application less than 2 years ago? YES

Lakhwinder Singh
SIGNATURE REQUIRED OF PERSON BEING FINGERPRINTED

**SPOUSAL AFFIDAVIT OF
NON PARTICIPATION INSERT**

NEBRASKA LIQUOR CONTROL COMMISSION
301 CENTENNIAL MALL SOUTH
PO BOX 95046
LINCOLN, NE 68509-5046
PHONE: (402) 471-2571
FAX: (402) 471-2814
Website: www.lcc.nebraska.gov

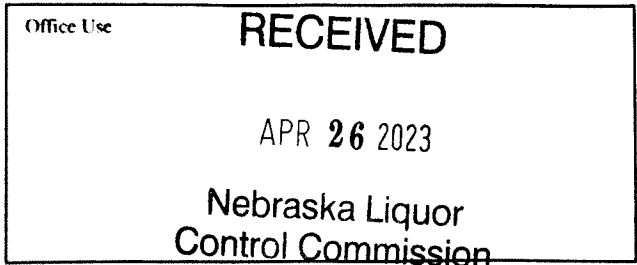

I acknowledge that I am the spouse of a liquor license holder. My signature below confirms that I will not have any interest, directly or indirectly in the operation of the business (§53-125(13)) of the Liquor Control Act. I will not tend bar, make sales, serve patrons, stock shelves, write checks, sign invoices, represent myself as the owner or **in any way participate in the day to day operations of this business in any capacity.** The penalty guideline for violation of this affidavit is cancellation of the liquor license.

I acknowledge that I am the applicant of the non-participating spouse of the individual signing below. I understand that my spouse and I are responsible for compliance with the conditions set out above. If, it is determined that my spouse has violated (§53-125(13)) the commission may cancel or revoke the liquor license.

Lakhwinder Kaur
Signature of **NON-PARTICIPATING SPOUSE**
LAKHWINDER KAUR
Print Name

Lakhwinder Singh
Signature of **APPLICANT**
LAKHWINDER SINGH
Print Name

State of Utah, County of Salt Lake The
foregoing instrument was acknowledged before me this
March 21, 2023 (date)
by Lakhwinder Kaur
Name of person acknowledged
(Individual signing document)

State of Utah, County of Salt Lake The
foregoing instrument was acknowledged before me this
March 21, 2023 (date)
by Lakhwinder Singh
Name of person acknowledged
(Individual signing document)

[Signature]
Notary Public Signature

[Signature]
Notary Public Signature

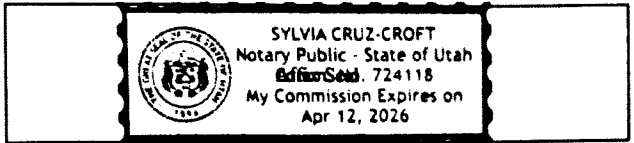
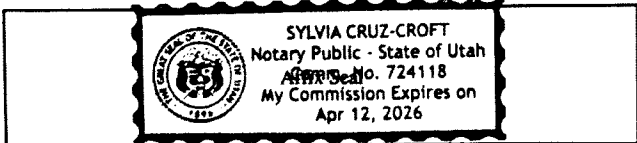

In compliance with the ADA, this spousal affidavit of non participation is available in other formats for persons with disabilities. A ten day advance period is requested in writing to produce the alternate format.

**PRIVACY ACT STATEMENT/
SUBMISSION OF FINGERPRINTS /
PAYMENT OF FEES TO NSP-CID**

NEBRASKA LIQUOR CONTROL COMMISSION
301 CENTENNIAL MALL SOUTH
PO BOX 95046
LINCOLN, NE 68509-5046
PHONE: (402) 471-2571
FAX: (402) 471-2814
Website: www.lcc.nebraska.gov



**THIS FORM IS REQUIRED TO BE SIGNED BY EACH PERSON BEING FINGERPRINTED:
DIRECTIONS FOR SUBMITTING FINGERPRINTS AND FEE PAYMENTS:**

- **FAILURE TO FILE FINGERPRINT CARDS AND PAY THE REQUIRED FEE TO THE NEBRASKA STATE PATROL WILL DELAY THE ISSUANCE OF YOUR LIQUOR LICENSE**
- Fee payment of \$45.25 per person **MUST** be made **DIRECTLY** to the Nebraska State Patrol;
It is recommended to make payment through the NSP PayPort online system at www.ne.gov/go/nsp
Or a check made payable to **NSP** can be mailed directly to the following address:
*****Please indicate on your payment who the payment is for (the name of the person being fingerprinted) and the payment is for a Liquor License*****
The Nebraska State Patrol – CID Division
4600 Innovation Drive
Lincoln, NE 68521
- Fingerprints taken at NSP LIVESCAN locations will be forwarded to NSP – CID
Applicant(s) will not have cards to include with license application.
- Fingerprints taken at local law enforcement offices may be released to the applicants;
Fingerprint cards should be submitted with the application.

Applicant Notification and Record Challenge: Your fingerprints will be used to check the criminal history records of the FBI. You have the opportunity to complete or challenge the accuracy of the information contained in the FBI identification record. The procedures for obtaining a change, correction, or updating a FBI identification record are set forth in Title 28, CFR, 16.34.

******Please Submit this form with your completed application to the Liquor Control Commission******

Trade Name Dual Stop Columbus- 14th st

Name of Person Being Fingerprinted: Maulin Patel

Date fingerprints were taken: 08/2021

Location where fingerprints were taken: Omaha

How was payment made to NSP?

NSP PAYPORT CASH CHECK SENT TO NSP CK # _____

My fingerprints are already on file with the commission – fingerprints completed for a previous application less than 2 years ago? YES

maulin patel
SIGNATURE REQUIRED OF PERSON BEING FINGERPRINTED

**SPOUSAL AFFIDAVIT OF
NON PARTICIPATION INSERT**

NEBRASKA LIQUOR CONTROL COMMISSION
301 CENTENNIAL MALL SOUTH
PO BOX 95046
LINCOLN, NE 68509-5046
PHONE: (402) 471-2571
FAX: (402) 471-2814
Website: www.lcc.nebraska.gov

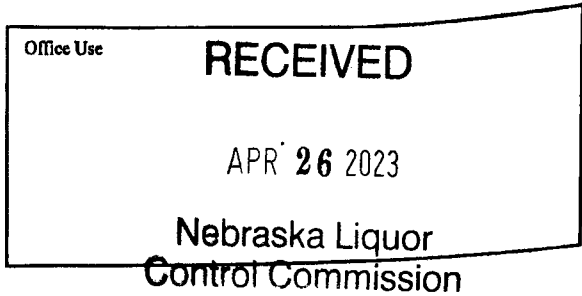

I acknowledge that I am the spouse of a liquor license holder. My signature below confirms that I will not have any interest, directly or indirectly in the operation of the business (§53-125(13)) of the Liquor Control Act. I will not tend bar, make sales, serve patrons, stock shelves, write checks, sign invoices, represent myself as the owner or in any way participate in the day to day operations of this business in any capacity. The penalty guideline for violation of this affidavit is cancellation of the liquor license.

I acknowledge that I am the applicant of the non-participating spouse of the individual signing below. I understand that my spouse and I are responsible for compliance with the conditions set out above. If, it is determined that my spouse has violated (§53-125(13)) the commission may cancel or revoke the liquor license.

M. M. Patel

Signature of **NON-PARTICIPATING SPOUSE**
Mexa Patel

Print Name

[Signature]

Signature of **APPLICANT**
Maulin Patel

Print Name

State of Nebraska, County of Douglas

State of Nebraska, County of Douglas

The foregoing instrument was acknowledged before me
this March 20, 2023 (date)

The foregoing instrument was acknowledged before me
this March 20, 2023 (date)

by Mexa Patel

Name of person acknowledged
(Individual signing document)

by Maulin Patel

Name of person acknowledged
(Individual signing document)

[Signature]

Notary Public Signature

[Signature]

Notary Public Signature

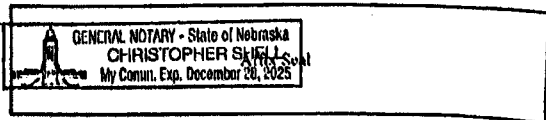
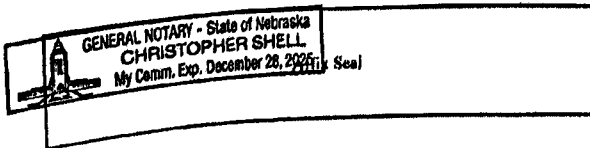

In compliance with the ADA, this spousal affidavit of non participation is available in other formats for persons with disabilities.
A ten day advance period is requested in writing to produce the alternate format.

BUSINESS PROPERTY LEASE

THIS LEASE is entered into this 30th day of March, 2023 between Korner Store Properties, LLC, a Nebraska limited liability company (hereinafter referred to as "Landlord"), and Balaji Petroleum, LLC, a Nebraska limited liability company (hereinafter referred to as "Tenant").

1. **PREMISES:** Landlord leases to Tenant the real property located at 3417 14th Street, Columbus, Nebraska 68601 (the "Premises"), as depicted in Exhibit A and containing approximately 12,508 square feet of area, on the following terms and conditions.

2. **TERM:** This Lease shall be for a term of thirty (30) years, beginning on the 1st day of March, 2023 (the "Commencement Date"), and ending on the 30th day of April, 2053, unless terminated earlier as provided in this Lease.

If for any reason the Premises is delivered to Tenant on any date before or after the term commencement date, rental for the period between the date of possession and the term commencement date shall be adjusted on a pro rata basis. Such earlier or later taking of possession shall not change the expiration date of this Lease. This Lease shall not be void or voidable in the event of a late delivery by Landlord, nor shall Landlord be liable to Tenant for any resulting loss or damage.

3. **USE OF PREMISES:** The Premises are leased to Tenant for the purpose of operating a gas station and convenience store and for no other purpose. Tenant agrees that its shall occupy and use the Premises in strict compliance with the terms of this Lease and the rules and regulations for the Real Estate (as hereinafter defined) attached hereto as Exhibit B, as may be amended by Landlord from time to time upon notice to Tenant, and its use of the Premises shall not interfere with the rights of other tenants at the Real Estate. For purposes of this Agreement, "Real Estate" shall mean, the real estate of which the Premises are part, including parking areas and grounds. Tenant further agrees to comply with all applicable governmental laws, ordinances, and regulations in connection with its use of the Premises, including without limitation all accessibility and environmental laws. Tenant shall keep the Premises in a clean and sanitary condition, and shall take all reasonable actions necessary to prevent waste, damage, or injury to the Premises. Tenant shall not house, maintain, or otherwise keep pets or animals of any kind at or on the Premises without the written consent of the Landlord, which consent may be granted, conditioned, and withdrawn in Landlord's sole discretion. Any such withdrawal of Landlord's consent pursuant to the preceding sentence shall be made by Landlord upon notice to Tenant. Any failure to comply with the terms of any such consent or the withdrawal thereof following notice hereunder shall constitute a material breach of this Lease.

4. **RENT:** Tenant shall pay as rent to Landlord each month the sum of Two Thousand Five Hundred and 00/100 Dollars (\$2,500.00). Tenant agrees to pay rent to Landlord: Korner Store Properties, LLC, 10708 M Street, Omaha, NE 68127, or at any other place Landlord may designate in writing, in lawful money of the United States, in monthly installments in advance, on the first day of each month without offset or demand by Landlord. Rent for any partial month shall be prorated based upon the actual number of days in such month included within the Term. If the Commencement Date is other than the first day of the month, the initial payment of rent shall be due on the Commencement Date.

(a) **Late Payment and Penalty.** Landlord and Tenant agree that if Landlord does not receive rental payments or any other amounts due to Landlord hereunder on or before fifteen (15) days after the date the payment is due, Tenant shall pay to Landlord, as additional rent, a late charge equal to five percent (5%) of the overdue amount; and (b) interest on the delinquent amounts from the date due to the date paid. The late charge and interest may be waived in writing only by Landlord.

(b) **Tenant Obligations.** Except as otherwise provided herein, all Rent shall be absolutely net to Landlord so that this Lease shall yield net to Landlord the Rent to be paid each month during the Term of this Lease. Accordingly, and except as otherwise provided in this Lease, all costs, expenses and obligations of every kind or nature whatsoever relating to the Premises which may arise or become due during the Term of this Lease including, without limitation, all costs and expenses of maintenance and repairs, insurance and taxes, shall be paid by Tenant. Landlord shall furnish no services to the Premises. Tenant shall pay when due, directly to the provider, all water, gas, electricity, sewer use fees and all other utility costs incurred at or chargeable to the Premises including, without limitation, all initial utility deposits and fees.

(c) **Security Deposit.** No security deposit will be required for this Lease.

5. **ASSIGNMENT OR SUBLEASE:** Tenant shall not assign this Lease or sublet the whole or any part of the Premises, transfer this Lease by operation of law or otherwise, or permit any other person except agents and employees of Tenant to occupy the Premises, or any part thereof, without the prior written consent of Landlord. Landlord may consider any factor it deems relevant in determining whether to withhold consent including, but not limited to, the following: (a) financial responsibility of the new tenant,

(b) identity and business character of the new tenant, and (c) nature and legality of the proposed use of the Premises. Landlord shall have the right to assign its interest under this Lease, the rent and any other amount(s) due hereunder.

6. TENANT'S IMPROVEMENTS: Tenant shall have the right to place partitions and fixtures and make improvements or other alterations in the interior of the Premises at its own expense. Prior to commencing any such work, Tenant shall first obtain the written consent of Landlord for the proposed work. Landlord may, as a condition to its consent, require that the work be done by Landlord's own agents and/or under Landlord's supervision, but at the expense of Tenant, and that Tenant give sufficient security that the improvements will be completed free and clear of liens and in a manner satisfactory to Landlord. Upon expiration or termination of this Lease, at Landlord's option, Tenant will repair and restore the Premises to its former condition, at Tenant's expense, or any such improvements, additions, or alterations installed or made by Tenant, except Tenant's trade fixtures, shall become part of the Premises and the property of the Landlord. Tenant may remove its trade fixtures at the expiration or termination of this Lease provided Tenant is not then in default and provided further that Tenant repairs any damage caused by such removal.

7. MAINTENANCE, REPAIRS AND REPLACEMENTS: Landlord shall (a) maintain the foundations and exterior walls (except store fronts, plate glass doors and other breakable materials used in structural portions), and if required by the proper governmental authorities, make modifications or replacements thereto, of the Real Estate, and (b) provide for roof replacement, but not repairs, of the Real Estate.

Tenant agrees that it will make, at its own cost and expense, all repairs and replacements to the Premises not required to be made by Landlord, including, but not limited to, all interior and exterior doors, door frames, windows, plate glass, and the heating, air conditioning, plumbing and electrical systems servicing the Premises. Tenant agrees to do all redecorating, remodeling, alterations, and painting required by it during the term of the Lease at its own cost and expense, to pay for any repairs to the Premises or the Real Estate made necessary by any negligence or carelessness of, or breach of this Lease by, Tenant or any of its agents or employees or persons permitted on the Real Estate by Tenant, and to maintain the Premises in a safe, clean, neat, and sanitary condition. Tenant shall be entitled to no compensation for inconvenience, injury, or loss of business arising from the making of any repairs or replacements or maintenance by Landlord, Tenant, or other tenants to the Premises or the Real Estate.

Without limiting any of the foregoing, Tenant acknowledges and agrees it is necessary for Tenant to maintain appropriate temperature and moisture control at the Premises and to take all necessary measures, at Tenant's own cost, to prevent and retard mold, fungus, mildew, and other similar conditions from accumulating or occurring at the Premises. Tenant shall be solely responsible for any and all claims, losses and damages arising out of or caused by Tenant's breach of this subparagraph, including: (a) any repairs, replacements or damages to the Premises; (b) any repairs, replacements or damages to personal property; and (c) any personal injury or death to Tenant, other occupants of, and visitors to, the Premises.

8. CONDITION OF PREMISES: Except as provided herein, Tenant agrees that no promises, representations, statements, or warranties have been made on behalf of Landlord to Tenant respecting the condition of the Premises, or the manner of operating the Real Estate, or the making of any repairs or alterations to the Premises. Tenant hereby acknowledges and agrees that it has inspected the Premises. By executing this Lease and taking possession of the Premises, Tenant hereby further acknowledges and agrees that the Premises were in good and satisfactory condition when possession was taken, fit for Tenant's occupancy and use and any alterations or modifications required to the Premises shall be the responsibility of Tenant. Tenant shall, at the termination of this Lease, by lapse of time or otherwise, remove all of Tenant's property in accordance with the terms of this Lease and surrender the Premises to Landlord in as good condition as when Tenant took possession, normal wear excepted.

9. PERSONAL PROPERTY AT RISK OF TENANT: All personal property in the Premises shall be at the risk of Tenant only. Landlord shall not be liable for any damage to any property of Tenant, its agents or employees at the Premises caused by any reason whatsoever, including, without limitation, fire, theft, steam, electricity, sewage, gas or odors, or from water, rain, or snow which may leak into, issue or flow into the Premises from any part of the Real Estate, or from any other place, or for any damage done to Tenant's property in moving same to or from the Real Estate or the Premises. Tenant shall give Landlord, or its agents, prompt written notice of any damage to or defects in water pipes, gas or warming or cooling apparatus in the Premises.

10. LANDLORD'S RESERVED RIGHTS: Without notice to Tenant, without liability to Tenant for damage or injury to property, person, or business, and without effecting an eviction of Tenant or a disturbance of Tenant's use or possession or giving rise to any claim for setoff or abatement of rent, Landlord shall have the right to:

- (a) Change the name or street address of the Real Estate.

- (b) Install and maintain signs on the Real Estate.
- (c) Have access to all mail chutes according to the rules of the United States Post Office Department.
- (d) At reasonable times, to decorate, and to make, at its own expense, repairs, alterations, additions, and improvements, structural or otherwise, in or to the Premises, the Real Estate, or part thereof, and any adjacent Real Estate, land, street, or alley, and during such operations to take into and through the Premises or any part of the Real Estate all materials required, and to temporarily close or suspend operation of entrances, doors, corridors, elevators, or other facilities as necessary.
- (e) Possess passkeys to the Premises.
- (f) Show the Premises to prospective tenants at reasonable times.
- (g) Take any and all reasonable measures, including inspections or the making of repairs, alterations, and additions and improvements to the Premises or to the Real Estate, whether or not arising out of Tenant's breach of the terms of this Lease, which Landlord deems necessary or desirable for the safety, protection, operation, or preservation of the Premises or the Real Estate.
- (h) Approve all sources furnishing signs, painting, and/or lettering to the Premises, and approve all signs on the Premises prior to installation thereof.
- (i) Amend or modify any rules and regulations for the safety, care, order, operation, appearance, and cleanliness of the Real Estate.

11. INSURANCE: Tenant shall not use or occupy the Premises or any part thereof in any manner which could invalidate any policies of insurance now or hereafter placed on the Real Estate or increase the risks covered by insurance on the Real Estate or necessitate additional insurance premiums or policies of insurance, even if such use may be in furtherance of Tenant's business purposes. In the event any policies of insurance are invalidated by acts or omissions of Tenant, Landlord shall have the right to terminate this Lease or, at Landlord's option, to charge Tenant for extra insurance premiums required on the Real Estate on account of the increased risk caused by Tenant's use and occupancy of the Premises. Each party hereby waives all claims for recovery from the other for any loss or damage to any of its property insured under valid and collectible insurance policies to the extent of any recovery collectible under such policies; provided, this waiver shall apply only when permitted by the applicable policy of insurance.

12. INDEMNITY: Tenant shall indemnify, hold harmless, and defend Landlord from and against, and Landlord shall not be liable to Tenant on account of, any and all costs, expenses, liabilities, losses, damages, suits, actions, fines, penalties, demands, or claims of any kind, including reasonable attorney's fees and filing costs, asserted by or on behalf of any person, entity, or governmental authority arising out of or in any way connected with (a) a failure by Tenant to perform any of the agreements, terms, or conditions of this Lease required to be performed by Tenant; (b) a failure by Tenant to comply with any laws, statutes, ordinances, regulations, or orders of any governmental authority; or (c) any accident, death, or personal injury, or damage to, or loss or theft of property which shall occur on or about the Premises, or the Real Estate, except as the same may be the result of the gross negligence of Landlord, its employees, or agents.

13. LIABILITY INSURANCE: Tenant agrees to procure and maintain continuously during the entire term of this Lease, a policy or policies of commercial general liability insurance from a company or companies acceptable to Landlord, at Tenant's own cost and expense, insuring Landlord and Tenant from all claims, demands or actions; such policy or policies shall in addition to insuring Tenant protect and name the Landlord and Landlord's managing agent as an "Additional Insured" on a primary and non-contributory basis and shall provide coverage in a combined single limit per occurrence of at least \$2,000,000.00 including umbrella coverage for claims, demands or actions for bodily injury, death or property damage made by or on behalf of any person or persons, firm or corporation arising from, related to, or connected with the conduct and operation of Tenant's business in the Premises, or arising out of and connected with the use and occupancy of the Real Estate by the Tenant. Auto insurance if applicable with at least \$1,000,000 in coverage limits and workers compensation coverage if applicable as required by law with minimum employers liability limits of \$500,000. All such insurance provided by Tenant shall be with a carrier that has an A- or better rating by A.M. Best. Tenants policies must and also give the Landlord a minimum of ten (10) days' notice by the insurance company prior to cancellation, termination or change of such insurance. Tenant shall provide Landlord with copies of the policies or certificates evidencing that such insurance is in full force and effect and stating the term and provisions thereof. If Tenant fails to comply with such requirements for insurance, Landlord may, but shall not be obligated to, obtain such insurance and keep the same in effect, and Tenant agrees to pay Landlord, upon demand, the costs incurred by Landlord for such insurance. Landlord reserves the right to require certified copies of policies and/or endorsements.

14. DAMAGE BY FIRE OR OTHER CASUALTY: If, during the term of this Lease, the Premises shall be so damaged by fire or any other cause, except for damage for which Tenant is responsible

hereunder, so as to render the Premises untenable, the rent shall be abated while the Premises remain untenable; and in the event of such damage, Landlord may elect whether to repair the Premises or to cancel this Lease, and shall notify Tenant in writing of its election within sixty (60) days after such damage. In the event Landlord elects to repair the Premises, the work or repair shall begin promptly and shall be carried on without unnecessary delay. In the event Landlord elects not to repair the Premises, the Lease shall be deemed canceled as of the date of the damage. Such damage shall not extend the Lease term. Notwithstanding anything to the contrary contained in this paragraph, no election by Landlord hereunder shall be deemed a waiver or release of any right or remedy of Landlord to recover any damages, lost rent or other expenses for which Tenant is responsible pursuant to the terms of this Lease.

15. CONDEMNATION: If the whole or any part of the Premises shall be taken by public authority under the power of eminent domain, then the term of this Lease shall cease on that portion of the Premises so taken, from the date of possession, and the rent shall be paid to that date, with a proportionate refund by Landlord to Tenant of such rent as may have been paid by Tenant in advance. If the portion of the Premises taken is such that it prevents the practical use of the Premises for Tenant's permitted purposes, then Tenant shall have the right either (a) to terminate this Lease by giving written notice of such termination to Landlord not later than thirty (30) days after the taking, or (b) to continue in possession of the remainder of the Premises, except that the rent shall be reduced in proportion to the area of the Premises taken. In the event of any taking or condemnation of the Premises, in whole or in part, the entire resulting award of damages shall be the exclusive property of Landlord, including all damages awarded as compensation for diminution in value to the leasehold, without any deduction for the value of any unexpired term of this Lease, or for any other estate or interest in the Premises now or hereafter vested in Tenant.

16. DEFAULT OR BREACH: Each of the following events shall constitute a default or a breach of this Lease by Tenant:

- (a) If Tenant fails to pay Landlord any rent or other payments when due hereunder;
- (b) If Tenant vacates or abandons the Premises;
- (c) If Tenant files a petition in bankruptcy or insolvency or for reorganization under any bankruptcy act, or voluntarily takes advantage of any such act by answer or otherwise, or makes an assignment for the benefit of creditors;
- (d) If involuntary proceedings under any bankruptcy or insolvency act shall be instituted against Tenant, or if a receiver or trustee shall be appointed over all or substantially all of the property of Tenant, and such proceedings shall not be dismissed or the receivership or trusteeship vacated within thirty (30) days after the institution or appointment; or
- (e) If Tenant fails to perform or comply with any other term or condition of this Lease, or any of the rules and regulations established by Landlord, and if such nonperformance shall continue for a period of ten (10) days after notice thereof by Landlord to Tenant, time being of the essence.

17. EFFECT OF DEFAULT: In the event of any default or breach hereunder, in addition to any other right or remedy available to Landlord, either at law or in equity, Landlord may exert any one or more of the following rights:

- (a) Landlord may re-enter the Premises immediately and remove the property and personnel of Tenant, and shall have the right, but not the obligation, to store such property in a public warehouse or at a place selected by Landlord, at the risk and expense of Tenant;
- (b) Landlord may retake the Premises and may terminate this Lease by giving written notice of termination to Tenant. Without such notice, Landlord's retaking will not terminate the Lease. On termination, Landlord may recover from Tenant all damages proximately resulting from the breach, including the cost of recovering the Premises and the rent (including Tenant's Pro Rata Share of the Operating Expenses) due for the balance of the Lease term as though the Lease had not been terminated and the fair market rental value which sum shall be immediately due Landlord from Tenant;
- (c) Landlord may re-let the Premises or any part thereof for any term without terminating this Lease, at such rent and on such terms as it may, choose. Landlord may make alterations and repairs to the Premises. In addition to Tenant's liability to Landlord for breach of this Lease, Tenant shall be liable for all expenses of the re-letting, for any alterations and repairs made, and for the rent (including Tenant's Pro Rata Share of the Operating Expenses) due for the balance of the Lease term, which sum shall be immediately due Landlord from Tenant. The amount due Landlord will be reduced by the net rent received by Landlord during the remaining term of this Lease from re-letting the Premises or any part thereof. If during the remaining term of this Lease Landlord receives more than the amount due Landlord under this sub-paragraph, the Landlord shall pay such excess to Tenant, but only to the extent Tenant has actually made payment pursuant to this sub-paragraph;
- (d) Landlord may increase the amount of the Security Deposit required of Tenant under Paragraph 4(c), which shall be paid by Tenant within five (5) days of Landlord's notice to Tenant requesting the same. Any increase in the amount of the Security Deposit shall be in Landlord's reasonable discretion.

18. SURRENDER - HOLDING OVER: Tenant shall, upon expiration or termination of this Lease, whether by lapse of time or otherwise, peaceably and promptly surrender the Premises to Landlord. If Tenant remains in possession after the expiration or termination of this Lease, without a written lease duly executed by the parties, Tenant shall be deemed a trespasser. If Tenant pays, and Landlord accepts, rent for a period after expiration or termination of this Lease, Tenant shall be deemed to be occupying the Premises only as a tenant from month to month, subject to all the terms, conditions, and agreements of this Lease, except that the rent shall be two hundred percent (200%) the monthly rent specified in the Lease immediately before termination.

19. SUBORDINATION AND ATTORNMENT: Landlord reserves the right to place liens and encumbrances on the Premises superior in lien and effect to this Lease. This Lease, and all rights of Tenant hereunder, shall, at the option of Landlord, be subject and subordinate to any liens and encumbrances now or hereafter imposed by Landlord upon the Premises or the Real Estate or any part thereof, and Tenant agrees to execute, acknowledge, and deliver to Landlord, upon request, any and all instruments that may be necessary or proper to subordinate this Lease and all rights herein to any such lien or encumbrance as may be required by Landlord.

In the event any proceedings are brought for the foreclosure of any mortgage on the Premises, Tenant will attorn to the purchaser at the foreclosure sale and recognize such purchaser as the Landlord under this Lease. The purchaser, by virtue of such foreclosure, shall be deemed to have assumed, as substitute Landlord, the terms and conditions of this Lease until the resale or other disposition of its interest. Such assumption, however, shall not be deemed an acknowledgment by the purchaser of the validity of any then existing claims of Tenant against the prior Landlord.

Tenant agrees to execute and deliver such further assurances and other documents, including a new lease upon the same terms and conditions contained herein, confirming the foregoing, as such purchaser may reasonably request. Tenant waives any right of election to terminate this Lease because of any such foreclosure proceedings.

If during the term of this Lease, Tenant, or Tenant's bank or lender, requests Landlord to execute and deliver a waiver and/or subordination of Landlord's rights under this Lease in and to any property or assets of the Tenant, Tenant hereby agrees to reimburse Landlord for its expenses incurred in connection with the execution and delivery of any such waiver and/or subordination agreement, including its reasonable attorney fees and legal expenses. Nothing herein shall obligate Landlord to execute or deliver any such waiver or subordination agreement and Landlord shall not be deemed in default of this Lease if any waiver or subordination agreement is not ultimately agreed to by Landlord.

20. NOTICES: Any notice or demands given hereunder shall be in writing and personally delivered or sent by certified mail, postage prepaid, at the following addresses or at such other address as either party may from time to time designate in writing:

Landlord:

**Korner Store Properties, LLC
c/o Maulin Patel
10708 M Street
Omaha, NE 68127**

Tenant:

**Balaji Petroleum, LLC
c/o Maulin Patel
10708 M Street
Omaha, NE 68127**

Each such notice shall be deemed to have been given at the time it shall be personally delivered to such address or deposited in the United States mail in the manner prescribed herein.

21. COMPLIANCE WITH ADA: Tenant shall comply with and be responsible for all costs of complying with the Americans with Disabilities Act (ADA), the rules and regulations promulgated thereunder, and all other applicable laws, rules and regulations relating to accessibility within the Premises, including the making of any alterations and removal of barriers within the Premises. Tenant hereby agrees to indemnify and hold Landlord fully and completely harmless from any and all costs, loss, liability, claims, expenses, fees (including reasonable attorneys' and consultants' fees), penalties, fines, assertions and judgments asserted against or incurred by Landlord arising from or in connection with any claim that Tenant's occupancy or use of the Premises violates the ADA or other applicable laws, rules and regulations relating to accessibility.

22. MISCELLANEOUS:

(a) **Binding on Assigns.** All terms, conditions, and agreements of this Lease shall be binding upon, apply, and inure to the benefit of the parties hereto and their respective heirs, representatives, successors, and permitted assigns.

(b) **Amendment in Writing.** This Lease contains the entire agreement between the parties and may be amended only by subsequent written agreement.

(c) **Waiver - None.** The failure of Landlord to insist upon strict performance of any of the terms, conditions and agreements of this Lease shall not be deemed a waiver of any of its rights or remedies hereunder and shall not be deemed a waiver of any subsequent breach or default of any of such terms, conditions, and agreements. The doing of anything by Landlord which Landlord is not obligated to do hereunder shall not impose any future obligation on Landlord nor otherwise amend any provisions of this Lease.

(d) **No Surrender.** No surrender of the Premises by Tenant shall be effected by Landlord's acceptance of the keys to the Premises or of the rent due hereunder, or by any other means whatsoever, without Landlord's written acknowledgment that such acceptance constitutes a surrender.

(e) **Captions.** The captions of the various paragraphs in this Lease are for convenience only and do no define, limit, describe, or construe the contents of such paragraphs.

(f) **Applicable Law.** This Lease shall be governed by and construed in accordance with the laws of the State of Nebraska.

(g) **Partial Invalidity.** If any provision of this Lease is invalid or unenforceable to any extent, then that provision and the remainder of this Lease shall continue in effect and be enforceable to the fullest extent permitted by law.

23. ENVIRONMENTAL REPRESENTATIONS AND COVENANTS; INDEMNITY.

Tenant agrees that it shall not at any time use the Premises in whole or in part to refine, produce, store, handle, transfer, process or transport any of the following in any manner which could result in contamination of the Premises or could result in any violation of or costs or liability under any Environmental Regulation: hazardous substances, pollutant or contaminant, hazardous waste, toxic chemical, hazardous chemical, hazardous material as those terms are defined herein and in the Federal Comprehensive Environmental Response, Compensation, and Liability Act (42 U.S.C.A § 9601 [14] and [33]), any so-called "Superfund" or "Superlien" law, or other applicable federal, state, or local statute, ordinance, rule or regulation, nor shall Tenant permit any release or threatened release of any Hazardous Substance on the Premises, nor shall Tenant install or permit the installation of any underground storage tanks in or about the Premises. As used herein the term "Hazardous Substance", shall mean urea formaldehyde, polychlorinated biphenyls, asbestos, asbestos-containing materials, radioactive materials or wastes, petroleum products, or any waste material or other substance which would subject the owner of the Premises to any response costs, damages, penalties, or liabilities under any applicable Environmental Regulations. The term "Environmental Regulations" as used herein means any federal, state, or local laws, statutes, codes, ordinances, regulations, requirements or rules relating to any environmental matters, including the removal, handling, and disposal of hazardous or toxic waste materials or substances. Tenant shall notify Landlord immediately upon receipt from any governmental entity or agency of any violation or alleged violation of any Environmental Regulation. Tenant covenants that it will not violate or permit the violation of any Environmental Regulation during the term of this Lease or any extension thereof.

Tenant hereby agrees to indemnify and hold Landlord fully and completely harmless from any and all costs, loss, liability, claims, expenses, fees (including reasonable attorneys' and consultants' fees), penalties, fines, assertions and judgments asserted against or incurred by Landlord arising from or in connection with any breach by Tenant of the terms of this paragraph.

24. ADDITIONAL PROVISIONS:

(a) **Extension Option.** If Tenant is not in default or breach under the terms of this Lease, Tenant shall have the right to extend this Lease for one (1) extension period of thirty (30) years, under the same terms and conditions, except that the Base Rent will be as designated in Section 4(a), above. Tenant must provide written notice to Landlord of its intent to exercise this option to extend at least six (6) months before the expiration of the initial term.

[Remainder of Page Intentionally Left Blank;

Signature Page to Follow]

IN WITNESS WHEREOF, the parties hereto have executed this Lease the day and year first above written.

LANDLORD: maulin patel

By: Maulin Patel
Its: President

TENANT: maulin patel

By: Maulin Patel
Its: President

EXHIBIT B

RULES AND REGULATIONS

- (a) Tenant shall not place or erect any signs or identifying marks, trademarks, insignia or advertising on or about the Premises or the Real Estate except with the prior written consent of Landlord. In the event Tenant shall place or cause to be placed any sign, identifying marks, insignia or advertising on or about the Premises or the Real Estate without the prior written consent of Landlord, Landlord shall have the right and power to remove the same at Tenant's expense.
- (b) All loading and unloading of goods shall be done only at times, in the areas and through the entrances designated for that purpose by Landlord.
- (c) All garbage and refuse shall be kept in the kind of container specified by Landlord, and shall be placed outside of the Premises daily, prepared for collection and removed in the manner and at the times and place specified by Landlord. If Landlord provides or designates a service for collection of refuse and garbage, Tenant shall use that service, at Tenant's expense, provided the cost is reasonably competitive to any identical service available to Tenant. Tenant shall in all events pay for the costs of such service.
- (d) Nothing (including without limitation radio or television aerials) shall be placed or erected on the roof or exterior walls of the Premises without the prior written consent of Landlord, and it is understood that the exclusive use of the roof and exterior walls is reserved to Landlord. Anything so placed or erected on the roof or exterior walls shall be subject to removal without notice or liability at any time and any damage to the walls or roof caused by the removal shall be the responsibility of Tenant.
- (e) No loudspeaker, television, phonograph, radio, flashing light or other device shall be used in a manner so as to be heard or seen outside of the Premises without the prior written consent of Landlord.
- (f) No auction, fire, "lost our lease", bankruptcy or other selling-out/closing-down sales shall be conducted in or on the Premises or Real Estate without the prior written consent of Landlord.
- (g) Tenant shall maintain all display windows in a neat, attractive condition, and shall exhibit only first-class materials, goods and items in all display windows. Tenant shall not permit the display of any materials, goods or items which in the sole discretion of the Landlord are considered lewd, obscene, pornographic, or otherwise not in keeping with the standards of the Real Estate. Upon Landlord's written request, Tenant shall promptly repair, replace or refurbish any signs, painting, letterings, or displays of Tenant on the Premises, that have, in the reasonable opinion of Landlord, fallen into disrepair or no longer meet or satisfy the aesthetic conditions or appearance of the Real Estate.
- (h) The sidewalks, entry ways, loading areas, other common areas and other outside areas immediately adjoining the Premises shall be kept clear of debris and snow at all times by Tenant and Tenant shall not place or permit any obstructions, garbage, refuse, merchandise or displays in those areas.
- (i) Tenant and Tenant's employees shall park their cars only in those portions of the parking area designated by Landlord. Tenant shall furnish Landlord with automobile license numbers assigned to Tenant's car or cars of Tenant's employees, and shall notify Landlord of any changes within five (5) days. In the event Tenant or its employees fail to park their cars in the designated parking areas as aforesaid, then Landlord at its option may charge Tenant \$10.00 a day (plus any administrative cost and liquidated damages) for each car parked in any area other than those designated.
- (j) Tenant, its employees and/or its agents, shall not solicit business in the common areas, nor shall Tenant, its employees and/or its agents distribute any handbills or other advertising matter in the common areas or on automobiles parked in the common areas.
- (k) Tenant shall not carry on any trade or occupation, operate any instruments, apparatus, or equipment, or use the Premises in any manner which emits an odor or causes a noise discernible outside of the Premises or which may be deemed offensive in nature.
- (l) Tenant shall keep the Premises at a temperature sufficient to prevent water from freezing in pipes and fixtures.
- (m) Tenant shall not place or maintain any temporary fixture for the display of merchandise outside the Premises or within six feet of any entrances to the Premises, and Landlord shall have the right, without giving prior notice to Tenant and without any liability for damage, to remove any such display from the Premises, except as shall have first received the written approval of Landlord as to size, color, location, nature and display qualities.

(n) Tenant shall not house, maintain, or otherwise keep pets or animals of any kind at or on the Premises without the written consent of the Landlord, which consent may be granted, conditioned, and withdrawn in Landlord's sole discretion.

Business Plan for Balaji Petroleum, LLC d/b/a Dual Stop Columbus- 14th street

Balaji Petroleum, LLC will own and operate a convenience store and gas station in Columbus, Nebraska. It will sell alcoholic beverages off-sale, along with other snack foods and consumer goods that are standard in the C-store industry.



Margaret A. (Maggie) Rossiter she/her
ATTORNEY
402.978.5336
mrossiter@fraserstryker.com
fraserstryker.com

April 26, 2023

VIA E-MAIL: LCC.frontdesk@nebraska.gov
Nebraska Liquor Control Commission
Licensing Division
301 Centennial Mall South, 5th Floor
Lincoln, Nebraska 68509

RE: Balaji Petroleum Liquor License Application

Dear Team:

Enclosed is the application packet for the above referenced entity. This packet includes copies of:

- Form 100: Application for Liquor License
- Form 102: Limited Liability Company Insert
- Form 103: Manager Application Insert
- Form 147: Privacy Act Statements
- Form 116: Spousal Affidavits of Non-Participation

The fingerprints and Payport fees for this application have been submitted to the Commission. Please do not hesitate to reach out if you have any further concerns with this application.

Very truly yours,

A handwritten signature in black ink that reads 'Margaret A. Rossiter'.

Margaret A. (Maggie) Rossiter
FOR THE FIRM

MAR:

Fraser Stryker PC LLO

500 Energy Plaza, 409 South 17th Street, Omaha, NE 68102 — TEL: 402.341.6000 — FAX: 402.341.8290

8. PETITIONS AND COMMUNICATIONS - None

9. REPORTS OF CITY OFFICES

9.A. Schedule for library and city hall move to new community building.

COMMUNITY BUILDING PROJECT SCHEDULE			
TASK NAME	START	FINISH	NOTES
Rescue Mission Vacate Building and Site	6/15/2023	6/15/2023	Rescue Mission provided date
Rescue Mission Salvaging	6/16/2023	6/21/2023	
Rescue Mission Hazardous Material Abatement	6/22/2023	7/19/2023	
Rescue Mission Demo	7/20/2023	8/20/2023	Finish estimated
Library Relocation	6/5/2023	7/5/2023	Existing furniture and equipment moved as spaces become available
Library Book Move	6/28/2023	7/3/2023	
City Hall Relocation	6/5/2023	7/5/2023	Existing furniture and equipment moved as spaces become available
City Hall closed to public, work day for moving	7/3/2023	7/3/2023	Water office open in community building
City Hall operational in Community Building	7/5/2023	7/5/2023	
Community Building Ribbon Cutting Ceremony	7/8/2023	7/8/2023	
City Hall Salvaging and Potential Excess Furniture and Equipment Sale	7/6/2023	7/14/2023	
City Hall Hazardous Material Abatement	7/17/2023	8/20/2023	Possible concurrent work
City Hall Demo	8/21/2023	10/8/2023	Finish estimated
Former City Hall Site Parking Lot and Open Space	10/9/2023	11/30/2023	Subject to weather and site conditions
Final plantings and parking lot paint striping	TBD	TBD	May need to be spring 2024 pending weather and site conditions

10. REPORTS OF COUNCIL COMMITTEES

10.A.COMMITTEE OF THE WHOLE - June 5, 2023

10.A.1. Emergency medical services for Duncan Rural Fire District and Columbus Rural Fire District.

**Columbus Fire Department
Memorandum
For Record**

DATE: 31 May 2023
TO: Tara Vasicek, City Administrator
FROM: Ryan Gray, Fire Chief
RE: EMS to Platte County

RECOMMENDATION:

Staff is looking for guidance from Council as it pertains to the City providing primary Emergency Medical Services (EMS) to Duncan Rural Fire District and Columbus Rural Fire District.

DISCUSSION:

Staff has been working for quite a number of months trying to establish a long-term solution for the City to continue to provide EMS to Duncan and Columbus Rural Fire Districts. There have been many meetings with the work group to work on a solution, and we are at a point where Council should decide how to proceed.

We have been offered a 2-year conditional agreement for \$300,000/year by Duncan and Columbus Rural Fire Districts to continue to provide EMS to their respective areas, while the consider other long-term solutions. Staff has held firm that the solution is \$600,000/year in perpetuity, in order to hire and train 6 additional Firefighter/Paramedic to staff a second ambulance 24/7/365.

We are asking that Council provide guidance and make a determination on how they wish for us to proceed at this point.

FISCAL IMPACT:

Currently Unknown

ALTERNATIVES:

To be discussed.

SIGNATURE:

BY:  _____

CITY ADMINISTRATOR:  _____

10.A.2. Implementation of Discretionary Capital Improvement Project policy.



The City of Columbus

RESPONSIBLE • RESPONSIVE • REPUTABLE

Administration Office (402) 562-4232

Fax (402) 563-1380

MEMORANDUM

DATE: May 31, 2023

FROM: Jim Bulkley, Mayor & Tara Vasicek, City Administrator

TO: Columbus City Council, sitting as Committee of the Whole

RE: Discretionary Capital Improvement Project Policy

RECOMMENDATION:

Recommend to the Mayor and City Council that the Discretionary Capital Improvement Project Policy be adopted.

DISCUSSION:

The Mayor and I have been discussing how project development can be updated to increase elected official participation and overall community engagement. The annual capital improvement plan projects can be broken down into two main categories, necessary and discretionary. It is the discretionary capital improvement projects that require the most transparency and engagement for the projects to be a success.

We believe there will be many benefits to adopting the Discretionary Capital Improvement Project Policy including:

- Representation of the public interest: Elected officials are responsible for representing the interests of their constituents. Capital improvement projects often have a significant impact on the community, and elected officials play a crucial role in ensuring that the projects align with the needs and aspirations of the people they represent. Their involvement helps to ensure that the projects prioritize the well-being and development of the community.
- Accountability and transparency: Elected officials bring a level of accountability and transparency to capital improvement projects. They are accountable to the public and can be held responsible for the decisions made regarding the projects. Their involvement helps to ensure that the decision-making process is transparent and follows established procedures. This transparency will promote public trust and confidence in the projects.
- Allocation of resources: Elected officials are responsible for making decisions about the allocation of public resources, including funding for capital improvement projects. Their involvement ensures that the allocation of resources is fair, equitable, and based on the priorities of the community. They can consider competing demands for resources, balance the needs of different sectors, and make informed decisions that best serve the overall interests of the community.
- Public engagement and representation: Elected officials provide a platform for public engagement and representation in capital improvement projects. They act as a bridge between the community and project stakeholders, facilitating dialogue, and ensuring that the voices and concerns of the public are heard and considered. Their involvement helps to foster a sense of ownership and inclusivity, creating opportunities for community input and participation in decision-making processes.

Both Staff leadership and Elected officials have the responsibility of overseeing capital improvement projects to ensure that they are implemented effectively and efficiently. This process will improve the monitoring of progress, evaluation of outcomes, and will allow the City to transparently make adjustments as necessary to ensure the successful completion of projects. Staff and Elected officials both have the capacity to consider the long-term



implications and sustainability of projects, but in different ways. Joining efforts at the beginning of projects will ensure that both contribute to the overall development and well-being of the community for years to come.

Overall, the involvement of elected officials in capital improvement projects is important because it brings accountability, transparency, expertise, representation, and long-term planning to the decision-making process. It helps to ensure that projects are aligned with the needs and aspirations of the community and are carried out in a fair and responsible manner.

FISCAL IMPACT: None

CONCURRENCE: All Staff Leadership

SIGNATURE:

By: _____

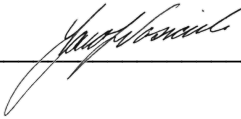
A handwritten signature in cursive script, appearing to read "Joseph Bonicini", is written over a horizontal line.

City of Columbus, Nebraska

Discretionary Capital Improvement Project Policy

This policy establishes guidelines and procedures for processing Discretionary Capital Improvement Projects (DCIP), ensuring the involvement of an elected official sponsor and a member of the staff leadership team in the development and execution of each project. The elected official will serve as the public spokesperson and advocate for the project during open meetings, while the staff members will provide professional expertise, research, and leadership during the project development, planning and implementation process.

1. Establishing Projects:

- 1.1. DCIP will be drawn from the annual capital improvement project list that is developed during the annual budget planning process.
- 1.2. During the annual budget development process each discretionary capital project will have one or more elected official sponsor(s). Any DCIP which fails to gain the support of an elected official will not be included in the City's budget. Each elected official will select and rank which DCIP they would like to sponsor. In order to follow the Open Meetings Act, a quorum of elected officials may not be the sponsor of any one DCIP.
- 1.3. Elected officials may request a capital improvement project be included in the annual capital improvement project list in January of each calendar year.
- 1.4. Establishing project priority for the DCIP will be done by the Mayor and City Council after the final DCIP list is finalized. This will be done by each elected officials ranking all of the discretionary capital improvement projects. (If there are 40 DCIP, they will rank those projects from 1 to 40. 1 being the most desired, 40 being the least desired. Projects with the least cumulative points will have the highest priority. Projects with the most cumulative points will have the lowest priority.)

2. Project Sponsorship:

- 2.1. All discretionary capital improvement projects must have an elected official sponsor who will advocate for and support the project throughout its lifecycle.
- 2.2. The elected official sponsor will collaborate with the staff leadership team to provide the necessary direction, resources, and oversight for the project.
- 2.3. The elected official sponsor will act as the public spokesperson for the project during open meetings, providing updates, answering questions, and representing the project to the public.
- 2.4. The City of Columbus will manage resources on the city's website to educate the public on what elected officials are sponsoring what projects.

- 2.5. The elected official sponsor will work together with staff leadership and the city Communication Manager to educate the public on the project, as the team feels necessary.
3. Staff Leadership Team:
 - 3.1. A member of the staff leadership team will be assigned to each discretionary capital improvement project to provide professional expertise and leadership in its development and execution.
 - 3.2. The staff leadership team member will be responsible for conducting research, following applicable rules and regulations, and leading the planning process for the project.
 - 3.3. The staff leadership team member will collaborate closely with the elected official sponsor to ensure alignment with project goals, objectives, and public interests.
4. Project Development Process:
 - 4.1. The elected official sponsor and the staff leadership team member will work together to define the project scope, objectives, and feasibility.
 - 4.2. The staff leadership team member will conduct research, analyze data, and develop a comprehensive plan for the project, including cost estimates, timelines, and required resources.
 - 4.3. The staff leadership team member will engage with relevant stakeholders, such as community members, government agencies, and other departments, to gather input and address concerns during the planning process. The elected official will join in this engagement when desired.
 - 4.4. The staff leadership team member will prepare project documentation, including reports, proposals, and presentations, for review and approval by appropriate authorities.
5. Execution and Oversight:
 - 5.1. Once the project receives necessary approvals, the staff leadership team member will oversee the implementation of the project plan, ensuring adherence to timelines, budgetary constraints, and quality standards.
 - 5.2. The elected official sponsor will continue to advocate for the project and communicate updates to the public through open meetings, community forums, and other appropriate channels.
 - 5.3. The staff leadership team member will regularly report project progress to the elected official sponsor and provide necessary updates to stakeholders and the public as required in coordination with the city Communication Manager.
 - 5.4. The elected official sponsor and the staff leadership team member will address any issues, challenges, or changes that arise during project execution, ensuring effective resolution and adaptation.
6. Evaluation and Closure:

- 6.1. Upon completion of the discretionary capital improvement project, the staff leadership team member and elected sponsor will complete an evaluation to assess the project's success, outcomes and identify lessons learned, recommendations for future projects.
- 6.2. The project will be officially closed after the elected official sponsor and the staff leadership team member have obtained the necessary approvals, completed required documentation, and ensured proper project handover, as applicable.
7. Policy Review:
 - 7.1. This policy will be reviewed periodically to ensure its effectiveness and relevance, with any necessary updates or modifications implemented as deemed appropriate by the City Council.

This policy aims to establish a structured and collaborative approach for processing discretionary capital improvement projects, facilitating accountability, transparency, and efficient utilization of resources.

10.A.3. Review city council rules.



The City of **Columbus**

CITY CLERK'S OFFICE

Phone (402) 562-4224 • Fax (402) 563-1380

June 5, 2023

To: Mayor and City Council
From: Janelle Kline, City Clerk
Subject: City Council Rules

The Columbus City Code provides that the Rules of the City Council shall be adopted at the first meeting in July following a general and regular city election. Attached are the City Council Rules with proposed changes shown in red. The proposed changes have been reviewed by the city attorney.

A recommendation can be made to approve the City Council Rules at the June 5th Committee of the Whole meeting or this issue can be kept in committee and brought back to a Committee of the Whole meeting on June 19th for further discussion and a recommendation. A resolution adopting new City Council Rules will be presented at the July 5th City Council meeting.

By: 

Janelle Kline, City Clerk

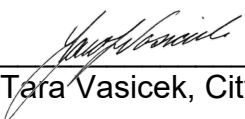
Approved: 

Tara Vasicek, City Administrator



From: [Bulkley, Jim](#)
To: [Kline, Janelle](#); [Beth Augustine-Schulte](#); [Charlie Bahr](#); [Hope Freshour](#); [Kat Lopez](#); [Prent Roth](#); [Richard Jablonski](#); [Ron Schilling](#); [Troy Hiemer](#)
Cc: [Vasicek, Tara](#); [Neal Valorz](#)
Subject: Re: June 5th Committee of the Whole - City Council Rules
Date: Monday, May 22, 2023 6:12:36 PM

All

I will be bringing a request to change our Council times to 5:30 PM. I believe that the 7:00 time was originally picked because we felt that it was best suited for citizens that wanted to attend our meeting. I think from the attendance that we normally get at our meetings it is pretty obvious that the start time has nothing to do with attendance. If it is a "hot" topic people will come.

I believe 5:30 would be much more friendly to our staff in the fact that they could easily roll from their work day assignments right into the council meeting. Not going home and back or waiting around town or the office for the meeting to start. I know that if you look at all of our sister city's and others our 7:00 start time is very unusual. Even look at our County Supervisor meetings-they start at 9:00 AM.

I feel that any current or future Council member that is working would be able to coordinate their schedules so that a 5:30 start would fit them also. A possible negative is the holding of a COW. Once in a while we have a COW that we schedule for an hour. And maybe 4:30 is putting a crimp on our working Council members. If that is a concern then I'd compromise and say that 6:00 could be our Council time and then any hour long COW wouldn't start till 5:00. And those are very seldom.

I believe we all would enjoy conducting our business and getting things done earlier thus getting us home sooner.

Jim

From: "Kline, Janelle" <Janelle.Kline@columbusne.us>
Subject: June 5th Committee of the Whole - City Council Rules
Date: 19 May 2023 11:31
To: "Beth Augustine-Schulte" <baugustine@neb.rr.com>, "Bulkley, Jim" <Jim.Bulkley@columbusne.us>, "Charlie Bahr" <cbahr1059@gmail.com>, "Hope Freshour" <freshourhope@gmail.com>, "Kat Lopez" <kat96lopez@gmail.com>, "Prent Roth" <jproth@yahoo.com>, "Richard Jablonski" <ward3rj2020@gmail.com>, "Ron Schilling" <firstbase57@allophone.com>, "Troy Hiemer" <troyhiemer@gmail.com>
Cc: "Vasicek, Tara" <Tara.Vasicek@columbusne.us>, "Neal Valorz" <nvalorz@1492law.com>

The Columbus City Code provides that the Rules of the City Council shall be adopted at the first meeting in July following a general and regular city election. Attached are the City Council

Rules that were adopted in 2021.

A Committee of the Whole meeting has been scheduled for June 5th to review the rules and a recommendation can be made at that time or the issue can be brought back to a June 19th Committee of the Whole meeting for further discussion and a recommendation. A resolution adopting the new rules will be presented at the first meeting in July.

I'm sending to you in advance to allow time for review. You can bring any proposed changes to the June 5th meeting for discussion.

Thank you.

Janelle Kline, CMC
City Clerk
City of Columbus
P.O. Box 1677
Columbus, NE 68602-1677
402-562-4227

Check us out at www.columbusne.us

RULES OF THE CITY COUNCIL OF THE CITY OF COLUMBUS, NEBRASKA

In accordance with Section 30.20 of the Columbus City Code, the following rules of procedures and order of business are adopted to ensure the orderly, efficient, and lawful conduct of the affairs of the City Council of Columbus, Nebraska.

I. ORGANIZATION OF THE COUNCIL

1. At the first regular meeting of the council in December following a regular city election, the newly elected members of the council who have qualified, as provided by law, together with the members of the council holding over, shall meet for the purpose of organization. They shall elect one of their members as “president of the council,” who shall hold such office until the first regular meeting of the council in December of the ensuing year, at which time such office shall automatically become vacant. The incumbent shall be eligible for re-election. In the absence of both the mayor and president of the council, the chair of the Public Finance, Judiciary, and Personnel Committee shall serve as acting president of the council, with the identical duties and powers of the president.
2. The council shall, by resolution, establish such standing and special committees as it deems necessary. Permanent standing council committees shall be (1) the Committee of the Whole; (2) the Public Finance, Judiciary and Personnel Committee; and (3) the Public Property, Safety and Works Committee. The Committee of the Whole, consisting of all members of the city council, shall be presided over by the council president, or in the president’s absence, by the chair of the Public Finance, Judiciary, and Personnel Committee. All other committees shall select their own chair and vice chair, each of whom shall serve for a term of one year, neither of which shall be the president of the council. The mayor shall at the first regular meeting in December submit to the council for their approval a list of council members to serve on each committee. Each committee shall have as its members one council member from each of the four Wards located in the City of Columbus. Changes on such committees may be made at any time by the mayor with the consent of the majority of all members of the council.

II. CONDUCT OF BUSINESS

1. Regular meetings of the council shall be held in the Council Chambers on the first and third Mondays of each month at ~~7:00~~7:30 p.m. Special meetings of the council shall be held in the Council Chambers upon call by the mayor or four members of the council. The day, hour, and purpose of such meetings shall be set forth in said call. No other business shall be transacted at such

special meetings unless all members are present and consent thereto. Notice of every special meeting shall be given to the mayor and each council member by notifying the mayor and council members personally, by telephone, by leaving a verbal message at the mayor's and council member's usual place of business or residence, or by email.

The council may, by motion, hold council meetings at such other locations and times as designated by a majority of the council.

Regular meetings of the city council may be rescheduled or cancelled by motion of the council.

2. In order for the council to conduct business, a majority of all members elected to the council must be present, but a lesser number may adjourn, from time to time, and compel the attendance of absent members. The quorum for the council committee meetings shall be a majority of the committee's members. The mayor's presence shall not be considered in a determination of a quorum.
3. All ordinances shall contain a title which shall briefly describe and explain the content of the respective ordinance and all ordinances shall contain no subject which shall not be clearly expressed in the title. All ordinances of a general or permanent nature shall be fully and distinctly read aloud, by title, on three (3) different days, unless three-fourths (3/4) of all members of the council vote to suspend this requirement, but only as permitted by state statute. In case such requirement shall be suspended, such ordinance shall be read by title or number and then moved for final passage. Three-fourths (3/4) of all members of the council may require any ordinance to be fully and distinctly read aloud in full before enactment under any of the procedures as set forth above.
4. All resolutions shall contain a title which shall briefly describe and explain the content of the respective resolution and all resolutions shall contain no subject which shall not be clearly expressed in the title. The resolution shall be read by title or number and then moved for final passage.
5. All ordinances and resolutions or orders for the appropriation or payment of money shall require for their passage or adoption the concurrence of a majority of all members elected to the council. The mayor may vote on any such matter when his or her vote will provide the additional vote required to create a number of votes equal to a majority of the number of the members elected to the council and the mayor shall, for the purpose of such vote, be deemed to be a member of the council.
6. The mayor shall have the power to approve or veto any ordinance passed by the city council and to approve or veto any order, bylaw, resolution, award of or vote to enter into any contract, or the allowance of any claim. If the mayor

approves the ordinance, order, bylaw, resolution, contract, or claim, he or she shall sign it, and it shall become effective. If the mayor vetoes the ordinance, order, bylaw, resolution, contract, or any item or items of appropriations or claims, he or she shall return it to the city council stating that the measure is vetoed. The mayor may issue the veto at the meeting at which the measure passed or within seven calendar days after the meeting. If the mayor issues the veto after the meeting, the mayor shall notify the city clerk of the veto in writing. The clerk shall notify the city council of the mayor's veto by email. Any ordinance, order, bylaw, resolution, award of or vote to enter into any contract, or the allowance of any claim vetoed by the mayor, may be passed over his or her veto by a vote of two-thirds of all the members elected to the council, notwithstanding his or her veto. If the mayor neglects or refuses to sign any ordinance, order, bylaw, resolution, award of or vote to enter into any contract, or the allowance of any claim, but fails to veto the measure within the time required by this section, the measure shall become effective without his or her signature. The mayor may veto any item or items of any appropriation bill or any claims bill, and approve the remainder thereof, and the item or items so vetoed may be passed by the council over the veto as in other cases.

7. The city administrator shall prepare the agenda for all meetings of the city council and its committees and a preliminary agenda shall be sent to the mayor. The city council shall, by motion, set a deadline for the submission of all items for the agenda. The mayor or a council member shall have the right to place a matter on the agenda of any regular or special meeting of the council or on the agenda of any committee of the city council by delivering a written request or by emailing a request to the city administrator with sufficient detail so as to fully comply with the Nebraska Open Meetings Act.
8. For purposes of various actions to be taken by the council, the following guidelines as to the number of votes required for various actions are as follows:
 - a. A majority of the council members present, or four votes, whichever number is greater, are required to transact business, except for specified exceptions.
 - b. Five votes of the council members are required to spend money, enter into a contract or pass a resolution.
 - c. Six votes of the council members are required to override a mayoral veto.
 - d. Six votes of the council members are required to suspend the rules for passage of an ordinance.

~~e. A vote of two-thirds (2/3) of the council members present is required to suspend the council rules that require a council member to leave the council chambers when abstaining from discussion and vote.~~

~~f.e.~~ Six votes of the council members are required to adopt an ordinance creating a water or sewer district.

~~g.f.~~ Five votes of the council members are required to enter into closed session.

~~h.g.~~ Five votes of the council members are required to adopt an ordinance, except following the veto of a mayor.

~~i.h.~~ Five votes of the council members are required to bring an item from the table.

~~j.i.~~ The mayor may vote on any such matter when his or her vote will provide the additional vote required to create a number of votes equal to a majority of the number of members elected to the council, and the mayor shall, for the purpose of such vote, be deemed to be a member of the council.

9. When at all possible, council members shall avoid motions containing negative statements.
10. A council member shall have the absolute right to change their vote up to the time the result of the vote is announced and the authority to change their vote with permission of five (5) members of the city council up to the time the meeting is adjourned.

III. ORDER OF BUSINESS

Unless otherwise approved by the city council at the operative meeting, the Order of Business will be conducted in the following order:

- Oath of Office. (When necessary/required.)
- Statement of compliance with Open Meetings Act and Roll Call.
- Prayer.
- National Anthem and Pledge of Allegiance.
- Appointment of City Officers. (When necessary/required.)
- Election of Council President. (When necessary/required.)
- Appointment of Council Members to Public Finance, Judiciary, and Personnel Committee and Public Property, Safety, and Works Committee. (When necessary/required.)
- Consent Agenda.
- Minutes.

- Special Presentations.
- Public Hearings.
- Petitions and Communications.
- Reports of City Offices.
- Reports of Council Committees.
- Reports of Special Committees.
- Reports on Legislation.
- New Business.
- Resolutions.
- Ordinances on First Reading.
- Ordinances on Second Reading.
- Ordinances on Third Reading.
- Consideration of Payroll and Bills on File.
- Unfinished Business.
- Adjournment.

This order of business may be changed from time to time by a motion duly made by a council member and a vote of the majority of members present at the council meeting. Further, items may be taken from this order of business and included for consideration in a consent agenda of “routine” items submitted for approval.

At the conclusion of all public hearings, a motion shall be made, seconded, and voted on to conclude the public hearing, continue it to a later date and time, or remove from the agenda. If the hearing is concluded, the council may immediately proceed to act on the issue of the hearing by approving, denying, or amending either a motion, a resolution, or an ordinance, as required.

IV. DECORUM AND DEBATE

1. The mayor shall preside at all meetings of the council. The mayor shall call the body to order at the hour provided by ordinance, preserve order and decorum, and decide all questions of order, subject to an appeal to the council. The mayor shall have supervision of the Council Chambers and in case of any disturbance or disorderly conduct, shall have the power to order the same cleared.
2. When any member is about to speak in debate or deliver any matter to the council, such member shall respectfully address the mayor, shall confine himself or herself to the question under debate, and avoid references to personal traits of any individual.
3. If a member be called to order for words spoken in debate, the member so calling shall repeat the words excepted to and they shall be taken in writing; and if, in the judgment of the council, the words excepted to are objectionable and the member uttering them refuses to retract, such member shall be subject to the censure of the council.

4. Every member of the council present at a meeting when the question is put shall give his or her vote as is his/her duty, unless ~~the council, for special reasons, shall excuse him or her from voting. All motions to excuse a member from voting shall be made prior to the matter for which the council member is seeking to be excused is otherwise discussed, debated, or addressed. Any member requesting to be excused from voting shall make a brief verbal statement of the reasons for making such a request and ask to leave the Council Chambers, as required by law~~ he/she abstains when required by law or as may be permitted under Robert's Rules of Order.
5. Every motion shall be reduced to writing upon the request of the mayor or any member of the council.
6. Upon calls of the council, or in taking the ayes and nays upon any question, the names of the members shall be called in regular order and so as to rotate the calling of the first name among the various members of the council, except when electronic balloting is used. All members of the council must vote on all issues unless excused from voting pursuant to the procedure set forth in Paragraph 4 above.
7. No member shall absent himself or herself from the service of the council, unless he or she is on leave, is sick, or unable to attend. If any council member shall neglect or fail to attend five consecutive regular meetings of the council, unless the absences are excused by a majority vote of the remaining Council Members, he or she shall be deemed guilty of misconduct and his or her office shall be declared vacant by the council. The vacancy shall be filled by appointment of the mayor, by and with the consent of the council, as provided by state statute.
8. The chief of Police, or any other police officer as designated by the chief of Police, shall be ex-officio Sergeant-at-Arms of the Council Chambers and it shall be that officer's duty to attend the council meeting, to execute the commands of the mayor and council as requested, and to serve such process or processes as may be issued by their authority.
9. Those individuals desiring to put an item or an issue on the agenda of a regular meeting of the city council shall submit such request in writing, completed on an approved "Topic for Consideration" form, to the city clerk's office stating the nature of the item they wish to discuss with the city council, and the request shall be submitted prior to 5 p.m. on the Monday immediately preceding the council meeting. This deadline may be amended by the council by motion and majority vote of the city council. Determination of whether the item or issue will be placed on the agenda is left to the discretion of the city administrator and the requesting citizen will be informed of the decision by 5 p.m. on the Friday immediately preceding the council meeting. The council shall not permit

individuals to address the city council relative to topics and issues which are not included on the council agenda.

10. Each person desiring to address the city council shall step up to the podium at the appropriate time; state his or her name and address for the record; state whom he or she is representing if such person represents an organization or other persons; and, limit his or her remarks to five (5) minutes, unless additional time is granted by the presiding officer or by a majority vote of the council. The presiding officer shall have the right to limit or exclude the presentation of information or testimony which is irrelevant or redundant. The presiding officer may reasonably limit the number of times during any meeting a person, not a member of the council, may address the council at the meeting.

V. MISCELLANEOUS

1. No standing rule of order of the council shall be rescinded, suspended, or amended, except by a vote of at least two-thirds (2/3) of the members present. Nor shall the order of business as established by the Rules of the city council be postponed or amended, except by a vote of at least two-thirds (2/3) of the members present.
2. The Rules of Parliamentary Practice, comprised in "Robert's Rules of Order Newly Revised, 12th Edition", shall govern the council in all cases where they are applicable and not inconsistent with these rules.
3. The mayor shall submit all appointments which he desires to have considered by the council not less than two weeks prior to the council meeting in which the appointment will be formally addressed. Provided, however, that if the appointment is a reappointment to the same or similar position, or is an appointment as a paid firefighter or paid police officer, this requirement shall be automatically waived without further action by the mayor or council. Additionally, the council may, upon motion being made, seconded, and approved, waive this requirement for other appointments at the council's discretion.
4. All committees previously appointed and approved by the mayor and council may appoint subcommittees consisting of the previously appointed members, or consisting of individuals not currently serving on the appointed board, only upon the mayor and council ratifying the creation of the subcommittee, its duties, and the individuals chosen by the committee to serve.
5. No council member shall allow himself or herself to be subject to excessive lobbying.

6. All lobbying, other than minimal contact, shall be reported to the city administrator and the lobbying reported to the other council members before the item, the subject of the lobbying, is discussed.

11. **REPORTS OF SPECIAL COMMITTEES - None**

12. **REPORTS ON LEGISLATION - None**

13. **NEW BUSINESS**

13.A.Appointment of Robbin Cutsor to Planning Commission to fill unexpired term of Kimberly Hoefler.

The City of **Columbus**

RESPONSIBLE • RESPONSIVE • REPUTABLE
Administration Office (402) 562-4232 Fax (402) 563-1380

MEMORANDUM

DATE: June 1, 2023
TO: City Council Members
FROM: James B Bulkley, Mayor
SUBJECT: Appointment

With your permission, I wish to submit the following name to you for appointment at the June 5, 2023, City Council meeting, and ask that the two-week waiting period be waived.

PLANNING COMMISSION

Robbin Cutsor

**(Filling unexpired term of Kimberly Hoefler until July 2025)
3004 28th Street, Columbus, NE**

Robbin Cutsor is a Columbus resident and has worked at Schaecher Prokopec Wealth Management since 2013. Due to her flexible job and the encouragement of her employers, she has been able to volunteer in several capacities. Robbin recently served on the Park Board for the City of Columbus for the past 9 years. She is currently on the Board at Peace Lutheran Church and has taught the youth at Midweek. She is an Advocate for CASA Connection, serving also as the Treasurer. Ms. Cutsor has served in several different roles for Platte County Relay for Life, including being the co-chair for about 6 years. She is also a part of the Columbus Cancer Care Foundation, raising funds to provide resources for cancer patients and their families.

Robbin and her husband, Joel, have been married for 26 years, and have one child, Reagan, who will attend Concordia College in Seward this fall.

James B. Bulkley, Mayor
City of Columbus

City of Columbus, 2023. All rights reserved.

13.B. Quote from CDW Corporation in the amount of \$82,149.87 for Wi-Fi hardware and services for Pawnee Plunge water park, Pawnee Park baseball field, Memorial Stadium, Berne Square, Gerrard Park, and Frankfort Square.

Information Technology

☎ 402-562-4242

📠 402-562-4265

@ it@columbusne.us



City of Columbus

City Hall

2424 14th St.

P. O. Box 1677

Columbus, NE 68602

MEMORANDUM

DATE: 5/31/2023
TO: City Administrator / Mayor / City Council
FROM: Matt Soukup, Computer Network Technician
RE: City Parks Wi-Fi Hardware

RECOMMENDATION:

I recommend the approval of the CDW SOWs for Wi-Fi hardware for City Parks. The sites included are: Pawnee Plunge Water Park, Pawnee Park Baseball Field, Pawnee Park Memorial Stadium, Armory Park, Gerrard Park, and Frankfort Square. Cost includes hardware and estimated CDW services for implementation.

DISCUSSION:

The addition of Wi-Fi will give staff and the public access to internet in areas of each of these locations.

FISCAL IMPACT:

Cost will be \$82,149.87 including hardware and estimated CDW services cost. There will be additional costs outside of CDW's scope to extend fiber in Frankfort Square, electrical needs at multiple sites, and miscellaneous cables and parts. Funding for this project in the Capital Improvement plan is \$200,000.

CONCURRENCE:

None at this time.

ALTERNATIVES:

Staff makes no alternative recommendation.

SIGNATURE:

By: 
Matt Soukup, Computer Network Technician

Approved By: 
Heather Lindsley, Finance Director

Approved By: 
Tara Vasicek, City Administrator



SOLUTION PROPOSAL

Prepared for:

CITY OF COLUMBUS
2424 14TH ST
COLUMBUS, NEBRASKA 68601-5038
UNITED STATES

Client Executive:

Kathleen O'Konski
+1 (402) 689-6344
kathleen.okonski@cdw.com

Proposal Number: Q-00350662
Proposal Date: 05/31/2023
Expires: 06/30/2023
Description: City of Columbus WiFi
Currency: USD

Client Executive:
 Kathleen O'Konski
 +1 (402) 689-6344
 kathleen.okonski@cdw.com

CITY OF COLUMBUS
2424 14TH ST
COLUMBUS, NEBRASKA 68601-5038
UNITED STATES



Sirius Computer Solutions, LLC

Proposal Number: Q-00350662
Proposal Date: 05/31/2023
Expires: 06/30/2023
Description: City of Columbus WiFi
Attn:

Headquarters:
 10100 Reunion Place, Suite 500
 San Antonio, Texas 78216
 www.siriuscom.com
 Sirius Tax ID # 74-2836721

Franfort Square

<u>Part #</u>	<u>Description</u>	<u>Qty</u>	<u>Ext. Price</u>
C9200CX-12P-2X2G-E	Catalyst 9000 Compact Switch 12-Port PoE+, 240W, Essentials	1	\$1,098.46
CON-SSSNT-C920CXPO	SOLN SUPP 8X5XNBD Catalyst 9000 Compact Switch 12-Port PoE	1	\$468.20
C9200CX-NW-E-12	C9200CX Network Essentials, 12-port license	1	\$0.00
CAB-TA-NA	North America AC Type A Power Cable	1	\$0.00
SCAT9200CXUK9-179	Cisco Catalyst 9200CX XE 17.9 UNIVERSAL	1	\$0.00
C9200CX-DNA-E-12	C9200CX Cisco DNA Essentials, 12-Port Term Licenses	1	\$0.00
CON-SSTCM-C9200CPD	SOLN SUPP SW SUB C9200CX Cisco DNA Essentials, 12-Port Te	1	\$34.00
C9200CX-DNAE12-3Y	C9200CX Cisco DNA Essentials, 3Y Term License, 12P	1	\$146.43
NETWORK-PNP-LIC	Network Plug-n-Play Connect for zero-touch device deployment	1	\$0.00
RACKMNT-19-CMPACT	19 in Rackmount for 9200CX switches	1	\$49.90
C9124AXD-B	Wi-Fi 6 Outdoor AP, Directional Ant, -B Regulatory Domain	4	\$5,902.60
CON-SSSNT-C91B14XD	SOLN SUPP 8X5XNBD Wi-Fi 6 Outdoor AP, Directional Ant, -B	4	\$2,580.76
SW9124AX-CAPWAP-K9	Capwap software for Catalyst 9124AX	4	\$0.00
AIR-MNT-VERT1	Vertical pole/wall mounting kit for Catalyst APs	4	\$263.52
CDNA-A-C9124	Wireless Cisco DNA On-Prem Advantage, 9124 Tracking	4	\$0.00
DNA-A-5Y-C9124	C9124AX Cisco DNA On-Prem Advantage, 5Y Term, Trk Lic	4	\$0.00
AIR-DNA-A	Wireless Cisco DNA On-Prem Advantage, Term Lic	4	\$0.00
CON-SSTCM-AIRDNA	SOLN SUPP SW SUBAironet CISCO DNA Ad	4	\$645.20
AIR-DNA-A-5Y	Wireless Cisco DNA On-Prem Advantage, 5Y Term Lic	4	\$2,461.92
PI-LFAS-AP-T	Prime AP Term Licenses	4	\$0.00
PI-LFAS-AP-T-5Y	PI Dev Lic for Lifecycle & Assurance Term 5Y	4	\$0.00
AIR-DNA-A-T	Wireless Cisco DNA On-Prem Advantage, Term, Tracker Lic	4	\$0.00
AIR-DNA-A-T-5Y	Wireless Cisco DNA On-Prem Advantage, 5Y Term, Tracker Lic	4	\$0.00
AIR-DNA-NWSTACK-A	Wireless DNA Perpetual Network Stack - Advantage	4	\$0.00
D-DNAS-EXT-BUN-T	Cisco DNA Spaces Extend Term License for Cisco DNA	4	\$0.00
D-DNAS-EXT-BUN-5Y	Cisco DNA Spaces Extend for Cisco DNA - 5Year	4	\$0.00
NETWORK-PNP-LIC	Network Plug-n-Play Connect for zero-touch device deployment	4	\$0.00
Franfort Square Subtotal:			\$13,650.99

Stadium

<u>Part #</u>	<u>Description</u>	<u>Qty</u>	<u>Ext. Price</u>
C9200CX-12P-2X2G-E	Catalyst 9000 Compact Switch 12-Port PoE+, 240W, Essentials	2	\$2,196.92
CON-SSSNT-C920CXPO	SOLN SUPP 8X5XNBD Catalyst 9000 Compact Switch 12-Port PoE	2	\$936.40
C9200CX-NW-E-12	C9200CX Network Essentials, 12-port license	2	\$0.00
CAB-TA-NA	North America AC Type A Power Cable	2	\$0.00
SCAT9200CXUK9-179	Cisco Catalyst 9200CX XE 17.9 UNIVERSAL	2	\$0.00
C9200CX-DNA-E-12	C9200CX Cisco DNA Essentials, 12-Port Term Licenses	2	\$0.00
CON-SSTCM-C9200CPD	SOLN SUPP SW SUB C9200CX Cisco DNA Essentials, 12-Port Te	2	\$68.00
C9200CX-DNAE12-3Y	C9200CX Cisco DNA Essentials, 3Y Term License, 12P	2	\$292.86
NETWORK-PNP-LIC	Network Plug-n-Play Connect for zero-touch device deployment	2	\$0.00
RACKMNT-19-CMPACT	19 in Rackmount for 9200CX switches	2	\$99.80
C9124AXD-B	Wi-Fi 6 Outdoor AP, Directional Ant, -B Regulatory Domain	6	\$9,960.66
CON-SSSNT-C91B14XD	SOLN SUPP 8X5XNBD Wi-Fi 6 Outdoor AP, Directional Ant, -B	6	\$3,871.14
SW9124AX-CAPWAP-K9	Capwap software for Catalyst 9124AX	6	\$0.00
AIR-MNT-VERT1	Vertical pole/wall mounting kit for Catalyst APs	6	\$395.28
CDNA-A-C9124	Wireless Cisco DNA On-Prem Advantage, 9124 Tracking	6	\$0.00
DNA-A-5Y-C9124	C9124AX Cisco DNA On-Prem Advantage, 5Y Term, Trk Lic	6	\$0.00
AIR-DNA-A	Wireless Cisco DNA On-Prem Advantage, Term Lic	6	\$0.00
CON-SSTCM-AIRDNA	SOLN SUPP SW SUBAironet CISCO DNA Ad	6	\$967.80
AIR-DNA-A-5Y	Wireless Cisco DNA On-Prem Advantage, 5Y Term Lic	6	\$3,692.88
PI-LFAS-AP-T	Prime AP Term Licenses	6	\$0.00
PI-LFAS-AP-T-5Y	PI Dev Lic for Lifecycle & Assurance Term 5Y	6	\$0.00
AIR-DNA-A-T	Wireless Cisco DNA On-Prem Advantage, Term, Tracker Lic	6	\$0.00
AIR-DNA-A-T-5Y	Wireless Cisco DNA On-Prem Advantage, 5Y Term, Tracker Lic	6	\$0.00
AIR-DNA-NWSTACK-A	Wireless DNA Perpetual Network Stack - Advantage	6	\$0.00
D-DNAS-EXT-BUN-T	Cisco DNA Spaces Extend Term License for Cisco DNA	6	\$0.00
D-DNAS-EXT-BUN-5Y	Cisco DNA Spaces Extend for Cisco DNA - 5Year	6	\$0.00

NETWORK-PNP-LIC	Network Plug-n-Play Connect for zero-touch device deployment	6	\$0.00
C9124AXI-B	Wi-Fi 6 Outdoor AP, Internal Ant, -B Regulatory Domain	2	\$3,054.08
CON-SSSNT-C9124AXI	SOLN SUPP 8X5XNBD Wi-Fi 6 Outdoor AP, Internal Ant, -B Reg	2	\$1,211.90
SW9124AX-CAPWAP-K9	Capwap software for Catalyst 9124AX	2	\$0.00
AIR-AP-NO-BRACKET	AP Bracket not shipped	2	\$0.00
CDNA-A-C9124	Wireless Cisco DNA On-Prem Advantage, 9124 Tracking	2	\$0.00
DNA-A-5Y-C9124	C9124AX Cisco DNA On-Prem Advantage,5Y Term,Trk Lic	2	\$0.00
AIR-DNA-A	Wireless Cisco DNA On-Prem Advantage, Term Lic	2	\$0.00
CON-SSTCM-AIRDNAA	SOLN SUPP SW SUBAironet CISCO DNA Ad	2	\$322.60
AIR-DNA-A-5Y	Wireless Cisco DNA On-Prem Advantage, 5Y Term Lic	2	\$1,230.96
PI-LFAS-AP-T	Prime AP Term Licenses	2	\$0.00
PI-LFAS-AP-T-5Y	PI Dev Lic for Lifecycle & Assurance Term 5Y	2	\$0.00
AIR-DNA-A-T	Wireless Cisco DNA On-Prem Advantage, Term, Tracker Lic	2	\$0.00
AIR-DNA-A-T-5Y	Wireless Cisco DNA On-Prem Advantage, 5Y Term, Tracker Lic	2	\$0.00
AIR-DNA-NWSTACK-A	Wireless DNA Perpetual Network Stack - Advantage	2	\$0.00
D-DNAS-EXT-BUN-T	Cisco DNA Spaces Extend Term License for Cisco DNA	2	\$0.00
D-DNAS-EXT-BUN-5Y	Cisco DNA Spaces Extend for Cisco DNA - 5Year	2	\$0.00
NETWORK-PNP-LIC	Network Plug-n-Play Connect for zero-touch device deployment	2	\$0.00
AIR-MNT-VERT1=	Vertical pole/wall mounting kit for Catalyst APs	2	\$131.76
Stadium Subtotal:			\$28,433.04

Pawnee Plunge

<u>Part #</u>	<u>Description</u>	<u>Qty</u>	<u>Ext. Price</u>
C9200CX-12P-2X2G-E	Catalyst 9000 Compact Switch 12-Port PoE+, 240W, Essentials	1	\$1,098.46
CON-SSSNT-C920CXPO	SOLN SUPP 8X5XNBD Catalyst 9000 Compact Switch 12-Port PoE	1	\$468.20
C9200CX-NW-E-12	C9200CX Network Essentials, 12-port license	1	\$0.00
CAB-TA-NA	North America AC Type A Power Cable	1	\$0.00
SCAT9200CXUK9-179	Cisco Catalyst 9200CX XE 17.9 UNIVERSAL	1	\$0.00
C9200CX-DNA-E-12	C9200CX Cisco DNA Essentials, 12-Port Term Licenses	1	\$0.00
CON-SSTCM-C9200CPD	SOLN SUPP SW SUB C9200CX Cisco DNA Essentials, 12-Port Te	1	\$34.00
C9200CX-DNAE12-3Y	C9200CX Cisco DNA Essentials, 3Y Term License, 12P	1	\$146.43
NETWORK-PNP-LIC	Network Plug-n-Play Connect for zero-touch device deployment	1	\$0.00
RACKMNT-19-CMPACT	19 in Rackmount for 9200CX switches	1	\$49.90
C9124AXD-B	Wi-Fi 6 Outdoor AP, Directional Ant, -B Regulatory Domain	3	\$4,426.95
CON-SSSNT-C91B14XD	SOLN SUPP 8X5XNBD Wi-Fi 6 Outdoor AP, Directional Ant, -B	3	\$1,935.57
SW9124AX-CAPWAP-K9	Capwap software for Catalyst 9124AX	3	\$0.00
AIR-MNT-VERT1	Vertical pole/wall mounting kit for Catalyst APs	3	\$197.64
CDNA-A-C9124	Wireless Cisco DNA On-Prem Advantage, 9124 Tracking	3	\$0.00
DNA-A-5Y-C9124	C9124AX Cisco DNA On-Prem Advantage,5Y Term,Trk Lic	3	\$0.00
AIR-DNA-A	Wireless Cisco DNA On-Prem Advantage, Term Lic	3	\$0.00
CON-SSTCM-AIRDNAA	SOLN SUPP SW SUBAironet CISCO DNA Ad	3	\$483.90
AIR-DNA-A-5Y	Wireless Cisco DNA On-Prem Advantage, 5Y Term Lic	3	\$1,846.44
PI-LFAS-AP-T	Prime AP Term Licenses	3	\$0.00
PI-LFAS-AP-T-5Y	PI Dev Lic for Lifecycle & Assurance Term 5Y	3	\$0.00
AIR-DNA-A-T	Wireless Cisco DNA On-Prem Advantage, Term, Tracker Lic	3	\$0.00
AIR-DNA-A-T-5Y	Wireless Cisco DNA On-Prem Advantage, 5Y Term, Tracker Lic	3	\$0.00
AIR-DNA-NWSTACK-A	Wireless DNA Perpetual Network Stack - Advantage	3	\$0.00
D-DNAS-EXT-BUN-T	Cisco DNA Spaces Extend Term License for Cisco DNA	3	\$0.00
D-DNAS-EXT-BUN-5Y	Cisco DNA Spaces Extend for Cisco DNA - 5Year	3	\$0.00
NETWORK-PNP-LIC	Network Plug-n-Play Connect for zero-touch device deployment	3	\$0.00
Pawnee Plunge Subtotal:			\$10,687.49

Gerrard Park

<u>Part #</u>	<u>Description</u>	<u>Qty</u>	<u>Ext. Price</u>
C9200CX-12P-2X2G-E	Catalyst 9000 Compact Switch 12-Port PoE+, 240W, Essentials	2	\$2,196.92
CON-SSSNT-C920CXPO	SOLN SUPP 8X5XNBD Catalyst 9000 Compact Switch 12-Port PoE	2	\$936.40
C9200CX-NW-E-12	C9200CX Network Essentials, 12-port license	2	\$0.00
CAB-TA-NA	North America AC Type A Power Cable	2	\$0.00
SCAT9200CXUK9-179	Cisco Catalyst 9200CX XE 17.9 UNIVERSAL	2	\$0.00
C9200CX-DNA-E-12	C9200CX Cisco DNA Essentials, 12-Port Term Licenses	2	\$0.00
CON-SSTCM-C9200CPD	SOLN SUPP SW SUB C9200CX Cisco DNA Essentials, 12-Port Te	2	\$68.00
C9200CX-DNAE12-3Y	C9200CX Cisco DNA Essentials, 3Y Term License, 12P	2	\$292.86
NETWORK-PNP-LIC	Network Plug-n-Play Connect for zero-touch device deployment	2	\$0.00
RACKMNT-19-CMPACT	19 in Rackmount for 9200CX switches	2	\$99.80
C9124AXI-B	Wi-Fi 6 Outdoor AP, Internal Ant, -B Regulatory Domain	4	\$5,429.44
CON-SSSNT-C9124AXI	SOLN SUPP 8X5XNBD Wi-Fi 6 Outdoor AP, Internal Ant, -B Reg	4	\$2,423.80
SW9124AX-CAPWAP-K9	Capwap software for Catalyst 9124AX	4	\$0.00

AIR-AP-NO-BRACKET	AP Bracket not shipped	4	\$0.00
CDNA-A-C9124	Wireless Cisco DNA On-Prem Advantage, 9124 Tracking	4	\$0.00
DNA-A-5Y-C9124	C9124AX Cisco DNA On-Prem Advantage,5Y Term,Trk Lic	4	\$0.00
AIR-DNA-A	Wireless Cisco DNA On-Prem Advantage, Term Lic	4	\$0.00
CON-SSTCM-AIRDNAA	SOLN SUPP SW SUBAironet CISCO DNA Ad	4	\$645.20
AIR-DNA-A-5Y	Wireless Cisco DNA On-Prem Advantage, 5Y Term Lic	4	\$2,461.92
PI-LFAS-AP-T	Prime AP Term Licenses	4	\$0.00
PI-LFAS-AP-T-5Y	PI Dev Lic for Lifecycle & Assurance Term 5Y	4	\$0.00
AIR-DNA-A-T	Wireless Cisco DNA On-Prem Advantage, Term, Tracker Lic	4	\$0.00
AIR-DNA-A-T-5Y	Wireless Cisco DNA On-Prem Advantage, 5Y Term, Tracker Lic	4	\$0.00
AIR-DNA-NWSTACK-A	Wireless DNA Perpetual Network Stack - Advantage	4	\$0.00
D-DNAS-EXT-BUN-T	Cisco DNA Spaces Extend Term License for Cisco DNA	4	\$0.00
D-DNAS-EXT-BUN-5Y	Cisco DNA Spaces Extend for Cisco DNA - 5Year	4	\$0.00
NETWORK-PNP-LIC	Network Plug-n-Play Connect for zero-touch device deployment	4	\$0.00
AIR-MNT-VERT1=	Vertical pole/wall mounting kit for Catalyst APs	4	\$263.52
Gerrard Park Subtotal:			\$14,817.86

Armory Park

Part #	Description	Qty	Ext. Price
C9200CX-12P-2X2G-E	Catalyst 9000 Compact Switch 12-Port PoE+, 240W, Essentials	1	\$1,098.46
CON-SSSNT-C920CXPO	SOLN SUPP 8X5XNBD Catalyst 9000 Compact Switch 12-Port PoE	1	\$468.20
C9200CX-NW-E-12	C9200CX Network Essentials, 12-port license	1	\$0.00
CAB-TA-NA	North America AC Type A Power Cable	1	\$0.00
SCAT9200CXUK9-179	Cisco Catalyst 9200CX XE 17.9 UNIVERSAL	1	\$0.00
C9200CX-DNA-E-12	C9200CX Cisco DNA Essentials, 12-Port Term Licenses	1	\$0.00
CON-SSTCM-C9200CPD	SOLN SUPP SW SUB C9200CX Cisco DNA Essentials, 12-Port Te	1	\$34.00
C9200CX-DNAE12-3Y	C9200CX Cisco DNA Essentials, 3Y Term License, 12P	1	\$146.43
NETWORK-PNP-LIC	Network Plug-n-Play Connect for zero-touch device deployment	1	\$0.00
RACKMNT-19-CMPACT	19 in Rackmount for 9200CX switches	1	\$49.90
C9124XD-B	Wi-Fi 6 Outdoor AP, Directional Ant, -B Regulatory Domain	1	\$1,475.65
CON-SSSNT-C91B14XD	SOLN SUPP 8X5XNBD Wi-Fi 6 Outdoor AP, Directional Ant, -B	1	\$645.19
SW9124AX-CAPWAP-K9	Capwap software for Catalyst 9124AX	1	\$0.00
AIR-MNT-VERT1	Vertical pole/wall mounting kit for Catalyst APs	1	\$65.88
CDNA-A-C9124	Wireless Cisco DNA On-Prem Advantage, 9124 Tracking	1	\$0.00
DNA-A-5Y-C9124	C9124AX Cisco DNA On-Prem Advantage,5Y Term,Trk Lic	1	\$0.00
AIR-DNA-A	Wireless Cisco DNA On-Prem Advantage, Term Lic	1	\$0.00
CON-SSTCM-AIRDNAA	SOLN SUPP SW SUBAironet CISCO DNA Ad	1	\$161.30
AIR-DNA-A-5Y	Wireless Cisco DNA On-Prem Advantage, 5Y Term Lic	1	\$615.48
PI-LFAS-AP-T	Prime AP Term Licenses	1	\$0.00
PI-LFAS-AP-T-5Y	PI Dev Lic for Lifecycle & Assurance Term 5Y	1	\$0.00
AIR-DNA-A-T	Wireless Cisco DNA On-Prem Advantage, Term, Tracker Lic	1	\$0.00
AIR-DNA-A-T-5Y	Wireless Cisco DNA On-Prem Advantage, 5Y Term, Tracker Lic	1	\$0.00
AIR-DNA-NWSTACK-A	Wireless DNA Perpetual Network Stack - Advantage	1	\$0.00
D-DNAS-EXT-BUN-T	Cisco DNA Spaces Extend Term License for Cisco DNA	1	\$0.00
D-DNAS-EXT-BUN-5Y	Cisco DNA Spaces Extend for Cisco DNA - 5Year	1	\$0.00
NETWORK-PNP-LIC	Network Plug-n-Play Connect for zero-touch device deployment	1	\$0.00
Armory Park Subtotal:			\$4,760.49
Extended Subtotal:			\$72,349.87
Total Client Price:			\$72,349.87

Proposal Comments:**Terms and Conditions:**

Unless otherwise noted, price does not include shipping, handling or applicable tax which may be added at the time of invoice. All quoted shipping and handling charges or tax amounts are estimates only, and are subject to change upon invoicing. In the event CITY OF COLUMBUS ("Customer") requests expedited shipping, whether such request is made before or after acceptance of this Solution Proposal ("Proposal") by Customer, the price stated above for shipping and handling is subject to change.

This Proposal is subject to the Terms and Conditions below and/or any referenced agreements. Acceptance of this Proposal by an authorized representative of Customer will be deemed the equivalent of a Customer Purchase Order, which will authorize Sirius Computer Solutions, LLC. ("Sirius") to order the products listed in this Proposal. Until Sirius receives and accepts a Purchase Order or a signed copy of this Proposal for the solution proposed, pricing provided in this Proposal is subject to change based on manufacturer's pricing schedule. The products contained on this Proposal may be delivered to the Customer through multiple shipments based upon supplier availability, and

Customer agrees to pay one or more partial payments of the total purchase price stated above for any such partial shipment of products. For purposes of clarity, services being sold under this Proposal, whether Sirius' or a manufacturer's/vendor's, shall not be subject to shipping and handling and the terms related thereof.

Notwithstanding anything to the contrary in the Terms and Conditions below and/or any referenced agreements, Customer hereby agrees that the products listed on this Proposal are noncancelable, nonreturnable, and nonrefundable except with the express written permission of Sirius.

Your contract number(s), currently on file, is as follows:

Agreement Type: Customer Agreement signed 34239

All of the information provided in this Proposal is considered confidential and proprietary between Sirius and Customer. Information enclosed in this Proposal may not be disclosed, disseminated, or otherwise revealed to any party outside of Customer or any party within Customer's organization who is not privileged to receive such information, unless required by law.

The provision of the maintenance services contained on this Proposal (the "Maintenance Services") will be controlled by the terms and conditions of the applicable manufacturer and/or maintenance provider (hereinafter the "Provider"). If Customer removes a covered device from productive use and requests cancellation of the Maintenance Services on that device, in accordance with the Provider's terms and conditions, Customer must notify Sirius by email at the following address: OPU@siriuscom.com. Should Customer fail to send the request to the address above, processing of the cancellation shall be delayed and any associated credit with the cancellation may be reduced.

Accepted by:

CITY OF COLUMBUS

Approved by:

Sirius Computer Solutions, LLC

Signature of Authorized Representative

Signature of Authorized Representative

Printed Name

Printed Name

Title of Authorized Representative

Title of Authorized Representative

Date Signed

Date Signed

Ship to Contact (Name, Phone, & Email)

Bill to Contact (Name, Phone, & Email)

Ship to Address

Bill to Address

LETTER OF UNDERSTANDING

Customer

City of Columbus (“Customer”)

Project ID / Case Number

00606046

Overview

Customer has requested configuration of wireless access points and network equipment to support wireless coverage at each site. Customer has engaged CDW to provide the review, plan, configure and execute expertise to support this project.

Preliminary Scope of Work / Task List

CDW will provide:

Technical Oversight

- a. A Technical Lead will be assigned to provide technical oversight and ensure the engagement is delivered with high quality and meets the Customers’ expectations. The Technical Lead will perform the tasks listed below:
 - i. Act as the CDW overall technical lead for the Customer
 - ii. Understand the Customer’s business, operational and technical drivers and ensure the overall engagement meets the Customer’s requirements
 - iii. Help identify and report technical risks and recommend remediation
 - iv. Ensure assessment methodology is properly executed and is consistent with the SOW

Project Coordination

- b. CDW will provide a Project Coordinator (PC) who will manage the daily activities throughout the duration of the project. The PC serves as the primary point of contact for all Client stakeholders, OEM vendors, and the project team and will perform the following duties:
 - i. Coordinate with Client PMO office to ensure we are aligned to Client PM processes and reporting standards, as necessary
 - ii. Conduct a project kickoff that will include a review of the contract scope and approach, roles and responsibilities, and the initial communication plan
 - iii. Provide continuity through all phases of the project
 - iv. Work closely with Customer's primary point of contact to ensure all business processes are followed throughout the life of the project
 - v. Owns the project repository containing project management documents, task plans, and project deliverables (Customer will have ownership of all work product)
 - vi. with the Customer PM to complete all Customer required change and project management notifications and documentation



Scope of Services: Wireless Assessment

Location – Frankfort Square

Cisco Equipment to Install

- One (1) Cisco C9200CX-12P-2X2G-E
- Four (4) C9124AXD-B

Project Task

1. Meet with customer project team to understand the requirements
2. Provide technical resources (onsite) to support specific customer requested task
3. Obtain most current installation location diagram (digital format)
4. Ensure proper power available
5. Ensure all new equipment to be installed is onsite
6. Review current configs to determine validity and functionality going forward
7. Develop High Level/Low Level Diagrams including cable map drawing for switch connectivity
8. Complete implementation and cutover
9. Update documentation and diagrams

Methodology Detail

1. Review Project Scope, Roles, Responsibilities, Communication and other materials with stakeholders and sponsors.
2. A briefing & workshop, delivering a list of specific, actionable recommendations designed to implement and operate the customer purchased Cisco equipment
3. Consolidate all preliminary data gathered from consultant led briefings to define the strategies and solutions standards for the implementation plan
4. Review and validate all data with project team in preparation for cutover

Design Recommendations

1. Ensure switch configuration
2. Complete patch cable matrix

Additional Responsibilities

CDW Responsibilities

1. Provide an engineer to configure both the network switch and wireless access points
2. Provide documentation of completed installation

Customer Responsibilities

1. Provide engineer to support the project
2. Provide work area and access to any area to be surveyed
3. Provide accurate drawings of each floor of each building to be surveyed

Deliverables

1. Cable matrix
2. Knowledge transfer

Assumptions

Client and CDW will coordinate schedule providing advanced notice on changes and/or modifications.

Project Timeline

The project is expected to last approximately One (1) day; work will be performed remote.

Estimated Fees

The services scoped in this LOU could be performed by CDW for an ***estimated*** price of: \$1,960.00.

The price is an ***estimate*** based on CDW current understanding of Customer's requirements and the project scope summarized herein. A Statement of Work with final project scope and pricing (which may vary from the estimate above) will be provided upon finalization of Customer's requirements and success criteria for any hardware, software, and associated services.

LETTER OF UNDERSTANDING

Customer

City of Columbus (“Customer”)

Project ID / Case Number

00606046

Overview

Customer has requested configuration of wireless access points and network equipment to support wireless coverage at each site. Customer has engaged CDW to provide the review, plan, configure and execute expertise to support this project.

Preliminary Scope of Work / Task List

CDW will provide:

Technical Oversight

- a. A Technical Lead will be assigned to provide technical oversight and ensure the engagement is delivered with high quality and meets the Customers’ expectations. The Technical Lead will perform the tasks listed below:
 - i. Act as the CDW overall technical lead for the Customer
 - ii. Understand the Customer’s business, operational and technical drivers and ensure the overall engagement meets the Customer’s requirements
 - iii. Help identify and report technical risks and recommend remediation
 - iv. Ensure assessment methodology is properly executed and is consistent with the SOW

Project Coordination

- b. CDW will provide a Project Coordinator (PC) who will manage the daily activities throughout the duration of the project. The PC serves as the primary point of contact for all Client stakeholders, OEM vendors, and the project team and will perform the following duties:
 - i. Coordinate with Client PMO office to ensure we are aligned to Client PM processes and reporting standards, as necessary
 - ii. Conduct a project kickoff that will include a review of the contract scope and approach, roles and responsibilities, and the initial communication plan
 - iii. Provide continuity through all phases of the project
 - iv. Work closely with Customer's primary point of contact to ensure all business processes are followed throughout the life of the project
 - v. Owns the project repository containing project management documents, task plans, and project deliverables (Customer will have ownership of all work product)
 - vi. with the Customer PM to complete all Customer required change and project management notifications and documentation



Scope of Services: Wireless Assessment

Location – Stadium (Memorial Park/Baseball Field)

Cisco Equipment to Install

- Two (2) Cisco C9200CX-12P-2X2G-E
- Six (6) C9124AXD-B
- Two (2) C9124AXI-B

Project Task

1. Meet with customer project team to understand the requirements
2. Provide technical resources (onsite) to support specific customer requested task
3. Obtain most current installation location diagram (digital format)
4. Ensure proper power available
5. Ensure all new equipment to be installed is onsite
6. Review current configs to determine validity and functionality going forward
7. Develop High Level/Low Level Diagrams including cable map drawing for switch connectivity
8. Complete implementation and cutover
9. Update documentation and diagrams

Methodology Detail

1. Review Project Scope, Roles, Responsibilities, Communication and other materials with stakeholders and sponsors.
2. A briefing & workshop, delivering a list of specific, actionable recommendations designed to implement and operate the customer purchased Cisco equipment
3. Consolidate all preliminary data gathered from consultant led briefings to define the strategies and solutions standards for the implementation plan
4. Review and validate all data with project team in preparation for cutover

Design Recommendations

1. Ensure switch configuration
2. Complete patch cable matrix

Additional Responsibilities

CDW Responsibilities

1. Provide an engineer to configure both the network switch and wireless access points
2. Provide documentation of completed installation

Customer Responsibilities

1. Provide engineer to support the project
2. Provide work area and access to any area to be surveyed
3. Provide accurate drawings of each floor of each building to be surveyed

Deliverables

1. Cable matrix
2. Knowledge transfer

Assumptions

Client and CDW will coordinate schedule providing advanced notice on changes and/or modifications.

Project Timeline

The project is expected to last approximately One (1) day; work will be performed remote.

Estimated Fees

The services scoped in this LOU could be performed by CDW for an ***estimated*** price of: \$1,960.00.

The price is an ***estimate*** based on CDW current understanding of Customer's requirements and the project scope summarized herein. A Statement of Work with final project scope and pricing (which may vary from the estimate above) will be provided upon finalization of Customer's requirements and success criteria for any hardware, software, and associated services.

LETTER OF UNDERSTANDING

Customer

City of Columbus (“Customer”)

Project ID / Case Number

00606046

Overview

Customer has requested configuration of wireless access points and network equipment to support wireless coverage at each site. Customer has engaged CDW to provide the review, plan, configure and execute expertise to support this project.

Preliminary Scope of Work / Task List

CDW will provide:

Technical Oversight

- a. A Technical Lead will be assigned to provide technical oversight and ensure the engagement is delivered with high quality and meets the Customers’ expectations. The Technical Lead will perform the tasks listed below:
 - i. Act as the CDW overall technical lead for the Customer
 - ii. Understand the Customer’s business, operational and technical drivers and ensure the overall engagement meets the Customer’s requirements
 - iii. Help identify and report technical risks and recommend remediation
 - iv. Ensure assessment methodology is properly executed and is consistent with the SOW

Project Coordination

- b. CDW will provide a Project Coordinator (PC) who will manage the daily activities throughout the duration of the project. The PC serves as the primary point of contact for all Client stakeholders, OEM vendors, and the project team and will perform the following duties:
 - i. Coordinate with Client PMO office to ensure we are aligned to Client PM processes and reporting standards, as necessary
 - ii. Conduct a project kickoff that will include a review of the contract scope and approach, roles and responsibilities, and the initial communication plan
 - iii. Provide continuity through all phases of the project
 - iv. Work closely with Customer's primary point of contact to ensure all business processes are followed throughout the life of the project
 - v. Owns the project repository containing project management documents, task plans, and project deliverables (Customer will have ownership of all work product)
 - vi. with the Customer PM to complete all Customer required change and project management notifications and documentation



Scope of Services: Wireless Assessment

Location – Pawnee Plunge

Cisco Equipment to Install

- One (1) Cisco C9200CX-12P-2X2G-E
- Three (3) C9124AXD-B

Project Task

1. Meet with customer project team to understand the requirements
2. Provide technical resources (onsite) to support specific customer requested task
3. Obtain most current installation location diagram (digital format)
4. Ensure proper power available
5. Ensure all new equipment to be installed is onsite
6. Review current configs to determine validity and functionality going forward
7. Develop High Level/Low Level Diagrams including cable map drawing for switch connectivity
8. Complete implementation and cutover
9. Update documentation and diagrams

Methodology Detail

1. Review Project Scope, Roles, Responsibilities, Communication and other materials with stakeholders and sponsors.
2. A briefing & workshop, delivering a list of specific, actionable recommendations designed to implement and operate the customer purchased Cisco equipment
3. Consolidate all preliminary data gathered from consultant led briefings to define the strategies and solutions standards for the implementation plan
4. Review and validate all data with project team in preparation for cutover

Design Recommendations

1. Ensure switch configuration
2. Complete patch cable matrix

Additional Responsibilities

CDW Responsibilities

1. Provide an engineer to configure both the network switch and wireless access points
2. Provide documentation of completed installation

Customer Responsibilities

1. Provide engineer to support the project
2. Provide work area and access to any area to be surveyed
3. Provide accurate drawings of each floor of each building to be surveyed

Deliverables

1. Cable matrix
2. Knowledge transfer

Assumptions

Client and CDW will coordinate schedule providing advanced notice on changes and/or modifications.

Project Timeline

The project is expected to last approximately One (1) day; work will be performed remote.

Estimated Fees

The services scoped in this LOU could be performed by CDW for an ***estimated*** price of: \$1,960.00.

The price is an ***estimate*** based on CDW current understanding of Customer's requirements and the project scope summarized herein. A Statement of Work with final project scope and pricing (which may vary from the estimate above) will be provided upon finalization of Customer's requirements and success criteria for any hardware, software, and associated services.

LETTER OF UNDERSTANDING

Customer

City of Columbus (“Customer”)

Project ID / Case Number

00606046

Overview

Customer has requested configuration of wireless access points and network equipment to support wireless coverage at each site. Customer has engaged CDW to provide the review, plan, configure and execute expertise to support this project.

Preliminary Scope of Work / Task List

CDW will provide:

Technical Oversight

- a. A Technical Lead will be assigned to provide technical oversight and ensure the engagement is delivered with high quality and meets the Customers’ expectations. The Technical Lead will perform the tasks listed below:
 - i. Act as the CDW overall technical lead for the Customer
 - ii. Understand the Customer’s business, operational and technical drivers and ensure the overall engagement meets the Customer’s requirements
 - iii. Help identify and report technical risks and recommend remediation
 - iv. Ensure assessment methodology is properly executed and is consistent with the SOW

Project Coordination

- b. CDW will provide a Project Coordinator (PC) who will manage the daily activities throughout the duration of the project. The PC serves as the primary point of contact for all Client stakeholders, OEM vendors, and the project team and will perform the following duties:
 - i. Coordinate with Client PMO office to ensure we are aligned to Client PM processes and reporting standards, as necessary
 - ii. Conduct a project kickoff that will include a review of the contract scope and approach, roles and responsibilities, and the initial communication plan
 - iii. Provide continuity through all phases of the project
 - iv. Work closely with Customer's primary point of contact to ensure all business processes are followed throughout the life of the project
 - v. Owns the project repository containing project management documents, task plans, and project deliverables (Customer will have ownership of all work product)
 - vi. with the Customer PM to complete all Customer required change and project management notifications and documentation



Scope of Services: Wireless Assessment

Location – Gerrard Park

Cisco Equipment to Install

- Two (2) Cisco C9200CX-12P-2X2G-E
- Four (4) C9124AXI-B

Project Task

1. Meet with customer project team to understand the requirements
2. Provide technical resources (onsite) to support specific customer requested task
3. Obtain most current installation location diagram (digital format)
4. Ensure proper power available
5. Ensure all new equipment to be installed is onsite
6. Review current configs to determine validity and functionality going forward
7. Develop High Level/Low Level Diagrams including cable map drawing for switch connectivity
8. Complete implementation and cutover
9. Update documentation and diagrams

Methodology Detail

1. Review Project Scope, Roles, Responsibilities, Communication and other materials with stakeholders and sponsors.
2. A briefing & workshop, delivering a list of specific, actionable recommendations designed to implement and operate the customer purchased Cisco equipment
3. Consolidate all preliminary data gathered from consultant led briefings to define the strategies and solutions standards for the implementation plan
4. Review and validate all data with project team in preparation for cutover

Design Recommendations

1. Ensure switch configuration
2. Complete patch cable matrix

Additional Responsibilities

CDW Responsibilities

1. Provide an engineer to configure both the network switch and wireless access points
2. Provide documentation of completed installation

Customer Responsibilities

1. Provide engineer to support the project
2. Provide work area and access to any area to be surveyed
3. Provide accurate drawings of each floor of each building to be surveyed

Deliverables

1. Cable matrix
2. Knowledge transfer

Assumptions

Client and CDW will coordinate schedule providing advanced notice on changes and/or modifications.

Project Timeline

The project is expected to last approximately One (1) day; work will be performed remote.

Estimated Fees

The services scoped in this LOU could be performed by CDW for an ***estimated*** price of: \$1,960.00.

The price is an ***estimate*** based on CDW current understanding of Customer's requirements and the project scope summarized herein. A Statement of Work with final project scope and pricing (which may vary from the estimate above) will be provided upon finalization of Customer's requirements and success criteria for any hardware, software, and associated services.

LETTER OF UNDERSTANDING

Customer

City of Columbus (“Customer”)

Project ID / Case Number

00606046

Overview

Customer has requested configuration of wireless access points and network equipment to support wireless coverage at each site. Customer has engaged CDW to provide the review, plan, configure and execute expertise to support this project.

Preliminary Scope of Work / Task List

CDW will provide:

Technical Oversight

- a. A Technical Lead will be assigned to provide technical oversight and ensure the engagement is delivered with high quality and meets the Customers’ expectations. The Technical Lead will perform the tasks listed below:
 - i. Act as the CDW overall technical lead for the Customer
 - ii. Understand the Customer’s business, operational and technical drivers and ensure the overall engagement meets the Customer’s requirements
 - iii. Help identify and report technical risks and recommend remediation
 - iv. Ensure assessment methodology is properly executed and is consistent with the SOW

Project Coordination

- b. CDW will provide a Project Coordinator (PC) who will manage the daily activities throughout the duration of the project. The PC serves as the primary point of contact for all Client stakeholders, OEM vendors, and the project team and will perform the following duties:
 - i. Coordinate with Client PMO office to ensure we are aligned to Client PM processes and reporting standards, as necessary
 - ii. Conduct a project kickoff that will include a review of the contract scope and approach, roles and responsibilities, and the initial communication plan
 - iii. Provide continuity through all phases of the project
 - iv. Work closely with Customer's primary point of contact to ensure all business processes are followed throughout the life of the project
 - v. Owns the project repository containing project management documents, task plans, and project deliverables (Customer will have ownership of all work product)
 - vi. with the Customer PM to complete all Customer required change and project management notifications and documentation



Scope of Services: Wireless Assessment

Location – Armory Park

Cisco Equipment to Install

- One (1) Cisco C9200CX-12P-2X2G-E
- One (1) C9124AXD-B

Project Task

1. Meet with customer project team to understand the requirements
2. Provide technical resources (onsite) to support specific customer requested task
3. Obtain most current installation location diagram (digital format)
4. Ensure proper power available
5. Ensure all new equipment to be installed is onsite
6. Review current configs to determine validity and functionality going forward
7. Develop High Level/Low Level Diagrams including cable map drawing for switch connectivity
8. Complete implementation and cutover
9. Update documentation and diagrams

Methodology Detail

1. Review Project Scope, Roles, Responsibilities, Communication and other materials with stakeholders and sponsors.
2. A briefing & workshop, delivering a list of specific, actionable recommendations designed to implement and operate the customer purchased Cisco equipment
3. Consolidate all preliminary data gathered from consultant led briefings to define the strategies and solutions standards for the implementation plan
4. Review and validate all data with project team in preparation for cutover

Design Recommendations

1. Ensure switch configuration
2. Complete patch cable matrix

Additional Responsibilities

CDW Responsibilities

1. Provide an engineer to configure both the network switch and wireless access points
2. Provide documentation of completed installation

Customer Responsibilities

1. Provide engineer to support the project
2. Provide work area and access to any area to be surveyed
3. Provide accurate drawings of each floor of each building to be surveyed

Deliverables

1. Cable matrix
2. Knowledge transfer

Assumptions

Client and CDW will coordinate schedule providing advanced notice on changes and/or modifications.

Project Timeline

The project is expected to last approximately One (1) day; work will be performed remote.

Estimated Fees

The services scoped in this LOU could be performed by CDW for an ***estimated*** price of: \$1,960.00.

The price is an ***estimate*** based on CDW current understanding of Customer's requirements and the project scope summarized herein. A Statement of Work with final project scope and pricing (which may vary from the estimate above) will be provided upon finalization of Customer's requirements and success criteria for any hardware, software, and associated services.

13.C. Quote from Platte Valley Communications in the amount of \$106,290.80 for radio console for joint communications center.



The City of Columbus

RESPONSIBLE • RESPONSIVE • REPUTABLE

Communications (402) 564-3201

Fax (402) 565-0660

DATE: May 22, 2023
TO: Tara Vasicek, City Administrator
FROM: Rachel Pensick, Communications Director
RE: AVTEC Radio Console as a back-up radio

RECOMMENDATION:

To approve the purchase of an AVTEC Radio Console with two dispatcher positions from Platte Valley Communications.

DISCUSSION:

Public Safety Telecommunicators (PSTs) as 911 employees are classified as essential critical infrastructure workers by the Department of Homeland Security Critical Infrastructure and Cybersecurity Agency. The work performed by PSTs is critical to the health and safety of the community and must continue regardless of emergency circumstances. Currently there is no alternative communications option if the dispatch center should need to be evacuated, or equipment fails or sustains damage and becomes inoperable.

After discussing location options with Platte Valley Communications and Motorola, it was determined the most reasonable location was the Platte County Emergency Operations Center. The new console would connect to equipment already located at the Emergency Operation Center, and would not rely on any equipment at the Joint Communications Center.

Alternative locations would be six or seven times the cost, and that does not take into consideration construction, remodeling, or furniture purchases. Alternative location options would also rely on equipment located at the Joint Communications Center.

No other quotes were obtained because Motorola owns AVTEC, and Platte Valley Communications is the Joint Communication Center’s Manufacturer Representative for Motorola Products.

FISCAL IMPACT:

The cost of the console, two operating positions, tech time, and supplies is \$106,290.80. This is a budgeted item.

Concurrence:

The Joint Communications Committee reviewed and approved the purchase. RFCC Consulting also reviewed and found no issue with the quote.

SIGNATURE:

By: *Rachel Pensick*
Rachel Pensick – Communications Director

Approved: *Tara Vasicek*
Tara Vasicek – City Administrator

Approved: *Heather Lindsley*
Heather Lindsley – Finance Director



PLATTE VALLEY COMMUNICATIONS, INC.
 2215 I AVE
 PO BOX 505
 KEARNEY, NE 68848-0505



Quote

Number: 012300217

Date: 01/24/2023

1

Bill To:

COLUMBUS, CITY
 JOINT COMMUNICATIONS CE
 2424 14TH ST
 COLUMBUS, NE 68602-1677

Ship To:

COLUMBUS, CITY
 JOINT COMMUNICATIONS CE
 2424 14TH ST
 COLUMBUS, NE 68602-1677

Customer #	Salesperson	Customer PO #	Billing Phone	Contact	Frequency/Acct
COCICO	MICHAEL E EPLEY	PER RACHEL	402-564-3201	RACHEL PENSICK	

Ordered	Shipped	Item #	Description	Unit Price	Amount
1.00	0.00	SERVICE	QUOTE REQUEST	\$0.00 each	\$0.00
			QUOTE FOR A NEW AVTEC CONSOLE TO REPLACE THE EXISTING ZETRON M4010 AT EMERGENCY MANAGEMENT.		
2.00	0.00	NOTE	NOTE	\$11,565.00	\$23,130.00
			DSSFWSOUEXT1SK:		
			Scout EX Console - Tier 1 includes a license for a Scout Enterprise Console with Software Audio Package. Includes IRR. Software Key version.		
2.00	0.00	NOTE	NOTE	\$2,335.50	\$4,671.00
			DSACCCPU2WIN10		
			PC for Scout Console Packages, Dual NICs, MS Windows 10 Professional 64 bit OS		
2.00	0.00	NOTE	NOTE	\$929.70	\$1,859.40
			DSACCUSBHJB		
			Avtec USB jack box for software console. Designed for Scout version 4.8 and earlier running Software Media Workstation		
2.00	0.00	NOTE	NOTE	\$690.30	\$1,380.60
			DSACCUSBMIC		
			Avtec USB Desk Mic for software console.		
2.00	0.00	NOTE	NOTE	\$1,045.80	\$2,091.60
			DSACCUSBSPK2		
			Avtec USB dual speaker kit for software console		
2.00	0.00	NOTE	NOTE	\$148.50	\$297.00
			DSUSBHUB10		
			10 Port USB Hub, USB 3.0		

PLATTE VALLEY COMMUNICATIONS, INC.
 2215 I AVE
 PO BOX 505
 KEARNEY, NE 68848-0505



Quote

Number: 012300217

Date: 01/24/2023

2

Bill To:

COLUMBUS, CITY
 JOINT COMMUNICATIONS CE
 2424 14TH ST
 COLUMBUS, NE 68602-1677

Ship To:

COLUMBUS, CITY
 JOINT COMMUNICATIONS CE
 2424 14TH ST
 COLUMBUS, NE 68602-1677

Customer #	Salesperson	Customer PO #	Billing Phone	Contact	Frequency/Acct
COCICO	MICHAEL E EPLEY	PER RACHEL	402-564-3201	RACHEL PENSICK	

Ordered	Shipped	Item #	Description	Unit Price	Amount
6.00	0.00	NOTE	NOTE DSACCHED6WNC Complete 6W Headset, Plantronics EncorePro HW510 Noise Canceling Microphone with plug-prong base.	\$366.00	\$2,196.00
1.00	0.00	NOTE	NOTE DSSFWVPL1SK Redundant VPGate Software License for a maximum of 40 endpoints; up to 20 may be "B" Licenses. Software license version.	\$15,966.00	\$15,966.00
7.00	0.00	NOTE	NOTE DSOUTPOSTPLUS4R OUTPOSTPLUS RADIO GATEWAY, VOIP, 4 PORT, POE, P/S NOT INCLUDED.	\$3,828.60	\$26,800.20
1.00	0.00	NOTE	NOTE DSOUTPOSTPLUSCFG OUTPOSTPLUS CONFIGURATION TOOL. 1 REQUIRED PER SITE.	\$214.00	\$214.00
1.00	0.00	NOTE	NOTE DSACCNWTK24PSFP 24G-Port PoE+ 1U Managed Ethernet Switch with 4 SFP Slots	\$3,847.00	\$3,847.00
7.00	0.00	NOTE	NOTE DSOUTPOSTPLUSPSNA OUTPOSTPLUS POWER SUPPLY, NORTH AMERICA	\$107.00	\$749.00
1.00	0.00	NOTE	NOTE DSSVCCSLTPRM	\$1,664.00	\$1,664.00
5.00	0.00	NOTE	NOTE DSSVCCSLTSIE	\$2,000.00	\$10,000.00

PLATTE VALLEY COMMUNICATIONS, INC.
 2215 I AVE
 PO BOX 505
 KEARNEY, NE 68848-0505



Quote

Number: 012300217
 Date: 01/24/2023
 3

Bill To:
 COLUMBUS, CITY
 JOINT COMMUNICATIONS CE
 2424 14TH ST
 COLUMBUS, NE 68602-1677

Ship To:
 COLUMBUS, CITY
 JOINT COMMUNICATIONS CE
 2424 14TH ST
 COLUMBUS, NE 68602-1677

Customer #	Salesperson	Customer PO #	Billing Phone	Contact	Frequency/Acct
COCICO	MICHAEL E EPLEY	PER RACHEL	402-564-3201	RACHEL PENSICK	

Ordered	Shipped	Item #	Description	Unit Price	Amount
1.00	0.00	TECH MARK S	TECH TIME DESIGN, ORDER, RECEIVE AND INSTALL THE TWO POSITION AVTEC SCOUT CONSOLE. BUILD AND INSTALL THE CHANNEL INTERFACE CABLES. BUILD AND INSTALL THE LOGGING RECORDER INTERFACE CABLES. INSTALL THE NETWORK CABLING FROM THE CONSOLE RACK TO THE DISPATCH POSTIONS. INSTALL THE SYSTEM GROUNDING.	\$9,600.00 hrs	\$9,600.00
1.00	0.00	MISC SUPPLIES	MISC SUPPLIES MISC GROUNDING AND SUPPLIES CAT 6 JACKETED GROUND WIRE CAT 2 JACKETED GROUND WIRE. CONNECTORS. TIES.	\$1,825.00 each	\$1,825.00

K-TQ AVTEC CONSOLE QUOTE // PCEM LOCATION

Locations at: 3820 W. Arch Ave., Grand Island 308-382-6212
 2215 Ave. I, Kearney 308-237-9512
 211 E. 6th St., Lexington 308-324-6556

Subtotal	\$106,290.80
Freight	\$0.00
Miscellaneous	\$0.00
NE Tax Group Sales Tax Amount	\$0.00
Discount	\$0.00
Total	\$106,290.80
Amount Received	\$0.00
Net Due	\$106,290.80

This is an order. Please pay from invoice.

13.D. Quote from General Traffic Controls in the amount of \$140,980 for pedestrian crosswalk upgrades.



The City of
Columbus, Nebraska

PUBLIC WORKS DEPARTMENT

• Utility Billing • Water Production • Water/Sewer Utility • Wastewater
• Streets • MSW Transfer Station
Phone: 402-562-4260
Fax: 402-562-4265
www.columbusne.us

MEMORANDUM

DATE: May 31, 2023
TO: City Administrator / Mayor / City Council
FROM: Chuck Sliva, Public Works Director
RE: Quote for Rectangular Rapid Flash Beacon (RRFB) High Visibility Pedestrian Crosswalk Upgrades.

RECOMMENDATION:

Accept sole source quote for RRFB units. The quote is from General Traffic Controls in Spencer Iowa. The total cost to complete 14 crosswalks, is \$140,980.00. Funds for this project will come from CIP#21-77.

DISCUSSION:

The attached quote is from the sole source supplier General Traffic Controls. We have excellent working relationship from this company. Their control systems are on most all our traffic lights in town. Staff also has all the, training, programing and tech support items on laptop to trouble shoot those units in house, as well as a parts inventory on hand. Each crossing will cost \$9,132.00. City staff will install crossing upgrades. This order also gives us 14 spare break-away bases and poles.

FISCAL IMPACT:

The total cost is this project is, \$140,980.00, including shipping. Funds for this project are in the 22-23 Budget CIP fund 21-71. Total amount of fund is \$150.000.00

ALTERNATIVES:

Upgrades must be phased in to stay compliant.

SIGNATURE:

By: _____ Chuck Sliva
Chuck Sliva, Public Works Director

Approved By: _____ Heather Lindsley
Heather Lindsley, Finance Director

Approved By: _____ Tara Vasicek
Tara Vasicek, City Administrator





Quote #: 7151
 Date: 5/10/2023
 Project Name: Clete Borchers
 Project #: City of Columbus
 Project Location: Columbus, NE

Terms: Net 30 days

Freight: Prepaid & Add

Delivery: 90-120 Days ARO

We are pleased to submit the following quotation:

ITEM	QTY	DESCRIPTION	UNIT PRICE	EXTEND PRICE
001	14	DC RRFB Including: (2) Cabinets w/ Flashers, (2) 5-Light RRFB Light Bars, (2) Solar Panel, (2) Pushbuttons & PB Signs.	\$8,570.00	\$119,980.00
005	28	13' Pedestal Pole, Base, Bolts, Collar, Cap.	\$750.00	\$21,000.00

Total Above Equipment: \$140,980.00

Fr 1 Estimated Frt. Actual Will Be billed \$2,000.00

Quote is considered lump sum, individual prices given for your convenience. Partial orders are subject to price review.

Quoted without plans or specs.

Notes:

Customer is responsible for installation of above equipment.

RRFB Signs are NOT included.

General Traffic Controls, Inc retains title to all equipment until paid in full.

All past due accounts are subject to a 1.5% per month service charge.

Sales tax is not included. If applicable, tax will be added to invoice.

Prices subject to review 30 days from above date.

Should we be favored with your order, it will receive our prompt, personal attention.

THANK YOU!

Very truly yours,

GENERAL TRAFFIC CONTROLS, INC.

Amanda Brown

CONFIDENTIALITY WARNING: Unless otherwise indicated or obvious from the nature of the communication, the information contained in this transmission and any attachments are privileged and confidential, and intended for use by the above-named recipient only. If the reader of this message is not the intended recipient, or an employee or agent responsible to deliver it to the intended recipient, you are notified that any dissemination, distribution or copying of this communication and any attachments thereto is strictly prohibited. If you have received this communication in error, please immediately notify the sender by return email, and destroy all copies of this transmission and any attachments. Thank you.

13.E. Quote from Truck Center Companies in the amount of \$32,323.76 for emergency replacement motor for semi truck for transfer station.



The City of
Columbus, Nebraska

PUBLIC WORKS DEPARTMENT
• Utility Billing • Water Production • Water/Sewer Utility • Wastewater •
Streets • MSW Transfer Station
Phone: 402-562-4260
Fax: 402-562-4265
www.columbusne.us

MEMORANDUM

DATE: May 25, 2023,
TO: City Administrator/Finance Director
FROM: Chuck Sliva, Public Works Director
SUBJECT: Transfer Station Emergency Semi Engine Rebuild / Repair.

RECOMMENDATION: To except following attached quote from Truck Center Companies for the listed emergency replacement motor for the 2009 Freightliner Semi. The quoted amount is for a complete engine replacement in the amount of \$32,323.76

DISCUSSION: This needed replacement was in the fastest and most cost effective manner to repair the semi and get it back in service. This unit is needed to keep up with hauling of loads. With this rebuild it will put replacement of this truck out 4-5+ years. We will retain old motor for salvage of all usable parts and components, for future savings.

FISCAL IMPACT:

Funds for this repair will come from the budgeted repair & usable CIP Funds.

SIGNATURE:

By: _____ Chuck Sliva _____
Chuck Sliva, Public Works Director

Approved By: _____ Heather Lindsley _____
Heather Lindsley, Finance Director

Approved By: _____ Tara Vasicek _____
Tara Vasicek, City Administrator



City of Columbus

Quote Sheet for Purchases

Department: Transfer Station

Charge to Account Number: 570 / 57510

Department Head Approval: Chuck Sliva

Finance Director Review: Heather Lindberg
(For Purchases of \$5,000 to \$40,000)

City Administrator Approval: _____
(For Purchases of \$5,000 to \$40,000)

... Purchases between \$10,000 and \$40,000 need Council approval, also.

Date: 5/30/2023 Time: a.m.

Vendor Name: Truck Center Company Columbus Ne.

Vendor Employee Name: Randy

Telephone: 402--564- 7060

Quote For: Engine replacement 2009 Freightliner

Quote Includes:	Item Totals:
Complete engine changeout	\$32,323.76
Total:	\$32,323.76

Quote Excludes:

Delivery Date: 6/30/2023 Shipped By: _____

Shipped F.O.B. (Freight Paid): Yes No

Tax Excluded

City Employee Obtained Quote: Richard Eaton

Truck Center Companies

2357 East 29th Ave
 Columbus, NE 68601
 (402) 564-7060

CITY OF COLUMBUS - COMPLETE

Apr 26, 2023 07:39 AM

Home: YMMS: 2009 Freightliner M2 Series - M2-106
 Mobile: Engine: Mercedes-Benz MBE 900 EPA07 DDEC VI 6 CYL
 Work: License:
 Email: VIN: 1FVHCYDJ19HAM2954
 Odometer:

TYPE	DESCRIPTION	QTY	PRICE	HOURS	LINE TOTAL
Labor	ENGINE REPLACEMENT	-	-	30.0	\$4,950.00
Parts	COMPLETE ENGINE	1.0	\$26,073.76	-	\$26,073.76
Parts	MISC. PARTS/FLUIDS	1.0	\$1,000.00	-	\$1,000.00

Labor:	\$4,950.00
Parts:	\$27,073.76
Shop Supplies:	\$300.00
Hazardous Materials:	\$0.00
Labor Taxes:	\$0.00
Parts Taxes:	\$0.00
TOTAL:	\$32,323.76

Customer Signature: _____

Thank you for your business

City of Columbus

Quote Sheet for Purchases

Department: Transfer Station

Charge to Account Number: 570 / 57510

Department Head Approval: _____

Finance Director Review: *Heather Lindberg*
(For Purchases of \$5,000 to \$40,000)

City Administrator Approval: _____
(For Purchases of \$5,000 to \$40,000)

... Purchases between \$10,000 and \$40,000 need Council approval, also.

Date: 5/30/2023 Time: a.m.

Vendor Name: Full Throttle Repair

Vendor Employee Name: Albert

Telephone: 402-563-9199

Quote For: Engine replacement 2009 Freightliner

Quote Includes:	Item Totals:
Complete engine changeout	\$49,107.38
Total:	\$49,107.38

Quote Excludes:

Delivery Date: 6/30/2023 Shipped By: _____

Shipped F.O.B. (Freight Paid): Yes No

Tax Excluded

City Employee Obtained Quote: Richard Eaton

Full Throttle Truck & Trailer Repair, LLC 2255 E. 12th Avenue, Columbus, NE 68601 (402) 563-9199 After Hours: (402) 992-5665		INVOICE 7509	
DATE IN CUSTOMER'S ORDER NO. BUS. PHONE HOME PHONE	AM. P.M. DATE PROMISED ORDER WRITTEN BY	AM. P.M.	
NAME ADDRESS CITY STATE ZIP	LICENSE NO. CALL WHEN READY <input type="checkbox"/> YES <input type="checkbox"/> NO TERMS	MILEAGE MECHANIC/TECHNICIAN	EXT.
SERVICES REQUESTED / DESCRIPTION OF WORK			
Remove Install Engine Including all Necessary Components and Fluids to start Engine			
This is only a Quote			
TOTAL LABOR 3350 00 TOTAL PARTS 45707 38 TOTAL SUBLET MISC. SHOP SUPPLIES 50 00 DISPOSAL FEE TAX TOTAL 49107 38			



QTY.	PART NO. AND DESCRIPTION (All parts new unless otherwise specified)	AMOUNT	DATE	AMOUNT
1	Engine PC S60 14 Liter on Hwy 5 2002 - 2012	\$ 3300 00		00
1	Engine CORE	\$ 1200 50		50
11	15W40 Motor Oil	14 75	1602	25
2	Oil Filters	30 19	60	38
1	Fuel Filter	8 00	8	00
1	Fuel Water Sep	8 86	8	86
1	Front Engine Mount	18 83	18	83
2	Rear Engine Mount	49 19	98	38
1	A/C Belt	22 58	22	58
1	Fan Belt	36 95	36	95
TOTAL PARTS		45707 38		38

I hereby authorize the above repair work to be done along with the necessary materials. You and your employees may operate vehicle for purposes of testing, inspection, or delivery at my risk. An express mechanics lien is acknowledged on above vehicle to secure the amount of repairs thereto. It is understood that you will not be held responsible for loss or damage to vehicle or articles left in vehicle in case of fire, theft or any other cause beyond your control. PLEASE PAY FROM THIS INVOICE. NET 30 DAYS. A 1.5% MONTHLY LATE FEE WILL BE MADE ON PAST DUE ACCOUNTS.

SIGNATURE Albert SAVE OLD PARTS YES NO

13.F. Quote from Crouch Recreation, Inc. in the amount of \$32,801 for picnic tables for Frankfort Square.



The City of Columbus

RESPONSIBLE • RESPONSIVE • REPUTABLE

Administration Office (402) 562-4232

Fax (402) 563-1380

memorandum

DATE: May 17, 2023
TO: Tara Vasicek, City Administrator
FROM: Jean Van Iperen, Planning & Economic Development Coordinator
RE: Picnic Tables for Frankfort Square

RECOMMENDATION:

To approve the purchase of 4 ADA compliant and 8 regular 4' square picnic tables for the pads at Frankfort Square.

DISCUSSION:

Last month the City Council approved the installation of two concrete pads in Frankfort Square to be used for picnic areas. These tables will be installed in those spaces and will offer seating for residents and visitors. The tables are 4' square tables with bench seating attached. Since the tables will be placed in Frankfort Square and the Square is in the heart of the downtown a more upscale table was selected versus the traditional metal tables seen in many of the recreational parks around Columbus. The tables will have a recycled plastic redwood top. They will be surface mounted and feature a 3" and 4" sq. tubing on the frame. A picture of the table can be seen on the attached sheet of other options that were looked at.

FISCAL IMPACT:

The quote received from Crouch Recreation, Elkhorn, is for \$32,801.00 and includes freight.

ALTERNATIVE:

Not approve the purchase.

SIGNATURE:

By:

Approved by:



Crouch Recreation, Inc.
 1309 S 204th Street #330
 Elkhorn, NE 68022
 nicole@crouchrec.com
 www.crouchrec.com

Quote



ADDRESS
City of Columbus 2424 14th Street Columbus, NE 68602-1677

SHIP TO
Columbus Park Maintenance Department 1057 28th Ave. Columbus, NE 68601 Jean Vaniperen 402-562-4273

QUOTE #	DATE	EXPIRATION DATE
2602	05/09/2023	06/09/2023

TERMS

50% Deposit W/Order

SALES REP

Alexi Crouch

DATE	ACTIVITY	QTY	RATE	AMOUNT
05/09/2023	Thomas Steele Please Reference 20861 WDTS-3F-RPW-SFI-P Walden 4' Table - Recycled Plastic Weathered Redwood - 3 Flat Seats (ADA) - Surface Individual Post Mount - e-Steele COLOR: Black	4	2,296.00	9,184.00
05/09/2023	Thomas Steele RT1237-S-4 STUD 1/2 x 3-3/4 - Removable Concrete Anchor - Stainless Steel - 4 Each	4	20.00	80.00
05/09/2023	Thomas Steele WDTS-4F-RPW-SFI-P Walden 4' Table - Recycled Plastic Weathered Redwood - 4 Flat Seats - Surface Individual Post Mount - e-Steele COLOR: Black	8	2,559.00	20,472.00
05/09/2023	Thomas Steele RT1237-S-4 STUD 1/2 x 3-3/4 - Removable Concrete Anchor - Stainless Steel - 4 Each	8	20.00	160.00
05/09/2023	Freight	1	2,905.00	2,905.00

Items needed to place the order:

*If this project is tax-exempt and involving an installation, a form 17 will be required to place the order.

*Signed Quote

*If payment terms requires a deposit, we will need that in hand to place the order.

1.5% Late Fee will be added to any invoices past 14 days late of the due date.
Please see payment terms above.

SUBTOTAL

32,801.00

TAX

0.00

TOTAL

\$32,801.00

Accepted By

Accepted Date



The Walden™ Square Table is compatible with virtually any setting and has a choice of 2, 3, or 4 seats. The 2 and 3 seat options are wheelchair accessible. Finishes include ipe wood, recycled plastic, & embossed recycled plastic. The Walden™ Square Table is constructed with the following materials: 3x4 profiles, 1/2 x 3" flat bar, and 3" & 4" sq. tubing composes the frame. Installation methods include: in-ground or surface pedestal, or in-ground or surface individual post mount.

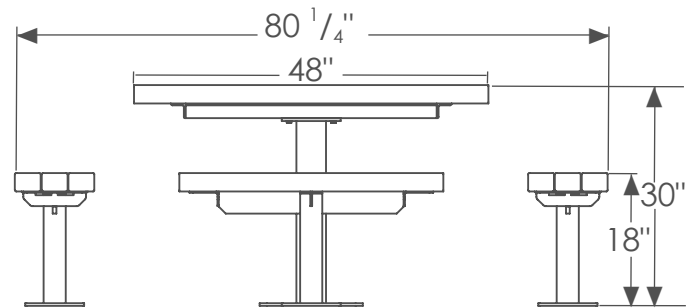

13.G.Request for proposals for purchase of land for Rural Workforce Housing project.



The City of Columbus

RESPONSIBLE • RESPONSIVE • REPUTABLE

Administration Office (402) 562-4232

Fax (402) 563-1380

memorandum

DATE: May 10, 2023

TO: Tara Vasicek, City Administrator

FROM: Jean Van Iperen, Planning & Economic Development Coordinator

RE: City Housing Subdivision

RECOMMENDATION:

Approval for the City to issue an RFP for land purchase for use of Rural Workforce Housing project.

DISCUSSION:

For several years the City has been trying to make an impact on the housing market by encouraging private developers to invest in new construction through the use of TIF and workforce housing funds. We have some successes, but we are not filling the gap in our housing stock fast enough. The City has experienced steady population growth since the 1990s and looking at Columbus' healthy job market (over 2,000 job openings today) the increase in population should continue. Even with the stronger than average housing construction activity the community has experienced in the last few years, it has not been enough to address the housing shortage. According to the development projections provided in the 2021 Housing Study 614 new doors are needed by 2025 just to meet the demand figuring out to be 153 homes each year. From the time of the study until now, in 2021 contractors built 68 single family homes and 20 duplex/townhomes and zero multifamily units (65 short of needed projections). In 2022, the City saw a decrease in housing built as interest rates and supply costs continued to rise with only 29 new single-family homes and 48 duplex/townhomes being construction (76 short of the needed projection numbers). In the last six months, City staff has seen the loss of new construction with developers backing off of developments of over 1,000 units. Developers are sitting too much risk in building out subdivisions and houses. Even with TIF and Workforce Housing funds, the gap in funding isn't being filled enough to provide the developer with the confidence needed to continue with their project.

As a community we need to do something different than has always been done. By removing the purchase of land and construction of public infrastructure from the developers and builders' risk, we can attract home builders and developers to building various housing types in Columbus. If the City can remove this risk then the developers/builders can get back to what they do best – building housing units. If the city could provide affordable lots in an area which has the infrastructure completed, we have a greater chance of bringing in regional builders who just want to build homes and begin to see an increase in new housing stock.

Staff would like approval to issue an RFP to acquire at least 20 acres of land to be used for creating a Subdivision to create Workforce Housing.



FISCAL IMPACT:

The City can fund this type of housing subdivision as capital improvement with local sales tax and can also use utility funds. Final funding decisions will be made by the City Council in conjunction with the budget preparation.

ALTERNATIVE:

Not approve the RFP process.

SIGNATURE:

By: 

Approved by:  _____

13.H. Comments from mayor and city council members.

14. **RESOLUTIONS**

14.A. Resolution No. R23-76 approving agreement with Mark S. Howerter, M.D. for medical direction and medical control of emergency medical dispatch.

RESOLUTION NO. R23-76

A RESOLUTION OF THE MAYOR AND COUNCIL OF THE CITY OF COLUMBUS, NEBRASKA, APPROVING THE AGREEMENT FOR MEDICAL DIRECTION AND MEDICAL CONTROL OF EMERGENCY MEDICAL DISPATCH FOR THE JOINT COMMUNICATIONS CENTER WITH DOCTOR MARK S. HOWERTER, A COPY OF WHICH IS ATTACHED HERETO AND INCORPORATED HEREIN; TO AUTHORIZE THE MAYOR TO EXECUTE THE SAME ON BEHALF OF THE CITY OF COLUMBUS; AND TO REPEAL ALL RESOLUTIONS OR PORTIONS THEREOF IN CONFLICT HEREWITH.

WHEREAS, the Joint Communication Center (“JCC”) is in need of a medical professional to provide medical director services to the JCC for its emergency medical dispatch program; and

WHEREAS, the City desires to engage Doctor Mark S. Howerter as a licensed physician to serve as the Medical Director for the EMD program at the JCC.; and

WHEREAS, a copy of the Agreement for Medical Direction and Medical Control of Emergency Dispatch with Doctor Mark S. Howerter is attached hereto and incorporated herein by this reference.

NOW THEREFORE, BE IT RESOLVED BY THE MAYOR AND COUNCIL OF CITY OF COLUMBUS, NEBRASKA, that the Agreement for Medical Direction and Medical Control of Emergency Dispatch with Doctor Mark S. Howerter, a copy of which is attached hereto and incorporated herein by this reference, is hereby approved; and, the Mayor is hereby authorized, directed, and empowered to the same on behalf of the City of Columbus, Nebraska.

This resolution shall repeal all resolutions or portions thereof in conflict herewith.

INTRODUCED BY COUNCIL MEMBER _____

PASSED AND ADOPTED THIS ____ DAY OF _____, 2023.

MAYOR

ATTEST:

CITY CLERK

APPROVED AS TO FORM:

CITY ATTORNEY



The City of Columbus

RESPONSIBLE • RESPONSIVE • REPUTABLE

Communications (402) 564-3201

Fax (402) 565-0660

DATE: May 22, 2023
TO: Tara Vasicek, City Administrator
FROM: Rachel Pensick, Communications Director
RE: Agreement for Medical Direction and Medical Control of Emergency Medical Dispatch

RECOMMENDATION:

To approve an agreement between the Columbus-Platte County Joint Communications Center and Dr. Mark Howerter for medical direction and medical control of Emergency Medical Dispatch.

DISCUSSION:

The Columbus-Platte County Joint Communications Center (JCC) is in the process of developing an Emergency Medical Dispatch (EMD) Program. The EMD program is an extension of the Emergency Medical Services system, in that patient care begins when the call is received in the communications center as opposed to waiting until the first response arrives at the scene.

Since EMD is a medical program, it requires medical oversight by a Medical Director. The Medical Director is a physician who has consented to assist with the program in this capacity. The JCC is using the APCO Intellicom EMD system, and according to the APCO Institute, "The Medical Director of the EMD program should be a local EMS physician who works closely with personnel in the EMS system; if possible, the director should be the same Medical Director as for the other parts of the EMS system." Dr. Mark Howerter serves in this capacity for several of the EMS agencies dispatched by the JCC.

If approved, this agreement will be renewed annually.

FISCAL IMPACT:

The cost of this agreement will provide the Medical Director a \$616.00 monthly salary, along with up to \$200.00 reimbursement for the purchase reference books or trade journal subscriptions. These costs are available in the Medical Director CIP project for the remainder of the year. Going forward, they will be budgeted as a reoccurring professional services cost.

Concurrence:

The Joint Communications Committee reviewed and approved the agreement. The agreement has also been reviewed by both the City Attorney and County Attorney.

SIGNATURE:
By: Rachel Pensick
Rachel Pensick – Communications Director

Approved: Tara Vasicek
Tara Vasicek – City Administrator

Approved: Heather Lindsley
Heather Lindsley – Finance Director



**AGREEMENT FOR MEDICAL DIRECTION
AND MEDICAL CONTROL OF
EMERGENCY MEDICAL DISPATCH**

THIS AGREEMENT is made and entered into as of the dates indicated below by and among the City of Columbus and Platte County (herein collectively referred to as “Client”), and Doctor Mark S. Howerter (herein collectively referred to as “Doctor”).

Recitals

WHEREAS, Client coordinates and/or operates the Columbus/Platte County Joint Communication Center (“JCC”); and

WHEREAS, Doctor is involved in the profession of emergency medical care, and is willing to provide medical director services to Client for its emergency medical dispatch program (herein after referred to as “EMD program”); and

WHEREAS, Client desires to engage the services of Doctor to serve as the medical director for the Client’s EMD program pursuant to the terms of this Agreement; and

NOW, THEREFORE, in consideration of the mutual promises herein contained, and other good and valuable consideration, the adequacy and receipt of which are acknowledged, it is agreed between the parties as follows:

Engagement

- 1.1. Medical Director. Client hereby engages Doctor as a licensed physician to serve as the Medical Director for the Client’s EMD program for its JCC. Client will name the Doctor as the designated physician and Medical Director for its EMD program.
2. Services To Be Provided by Doctor.
 - 2.1. Doctor shall:
 - i. Provide medical direction to Client’s designated supervisor of the JJC and EMD program and other personnel who are part of Client’s JJC and EMD program.
 - ii. Direct and supervise all medical phases of EMD program and the various personnel (dispatchers, etc.) operating under the EMD program.
 - iii. Oversee standard operating protocols, policies, procedures, standards, and guidelines (Protocols”) for the personnel operating under the EMD program and assist JCC in reviewing and drafting Protocols as requested.
 - a. Protocols are expected to meet current standards for service delivery and patient care, as well as nay that might be implanted during the term of this Agreement.
 - iv. Coordinate and supervise evaluation activities and quality assurance programs conducted under the EMD program.

- v. Consult, assist, and participate in educational programs for personnel who are part of Client's EMD program. EMD education will primarily remain the responsibility of the JCC; however, close oversight will be provided by the Doctor.
 - vi. Report periodically to JCC on activities and issues related to the functioning of the EMD program.
 - vii. Meet quarterly, or as necessary, with JCC to review protocols and present topical issues and current best practices.
 - viii. Review records of service calls to Client's EMD program to determine compliance with protocols, performance standards, and regulations, and recommend any remedial, disciplinary, or corrective actions to be taken.
- 2.2. Doctor as the Medical Director shall have and maintain the following qualifications:
- i. Be a Nebraska licensed physician without any limits on his licensure.
 - ii. Be board eligible or board certified with a current status in a professional recognized organization for active credentialing and privileges.
 - iii. Be a member in good standing with the local hospital.
3. Services of JCC. If any information, data, software, surveys, reports, photographs, and maps are existing and available and are useful for carrying out the EMD program plan or to the Medical Director, JCC shall promptly furnish copies of these materials or allow access to Doctor for use under this Agreement. JCC shall designate an individual to act as its representative with respect to the work to be performed under this Agreement, and such person shall have authority to transmit instructions, receive information, interpret, and define JCC's policies and provide decisions in a timely manner pertinent to the work covered by this Agreement.
- 3.1. Provide Doctor with access to all computer aided dispatch (CAD) records, EMD program records, quality assurance software/records, voice recordings of 911 calls, medical records and all other relevant data as pertains to the delivery of EMD program.
 - 3.2. Provide nonfinancial support for research activities dealing with prehospital emergency care and EMD program conducted by hospital.
 - 3.3. In conjunction with Doctor develop and implement quality assurance measures and keep Client's EMD program current.
 - 3.4. Follow all policies, procedures, medical guidelines and protocols as established by the Medical Director as they pertain to the EMD program.
4. Schedule. Doctor and JCC shall mutually determine the schedule for and performance of the various services hereunder.
5. Compensation. Client shall reimburse Doctor for Medical Director's time and efforts not to exceed \$616 per month during the term of this agreement. If Client fails to make any payment within sixty (60) days after receipt of invoice, Doctor may, after giving seven (7) days written

notice to Client, suspend service under this Agreement until all amounts due are paid in full, and/or seek other available remedies.

- i. Additionally, Client will reimburse Doctor up to \$200 per calendar year for items such as reference book or trade journal subscriptions. Any reimbursement for amounts over the aforementioned \$200 per calendar must be pre-authorized by the JCC Director.
6. Terms of Agreement. This Agreement shall be effective as of _____, _____, and continue through the _____, _____, unless otherwise terminated as provided herein. This Agreement and all its terms and conditions shall automatically renew thereafter on a year-to-year basis unless a party gives written notice of non-renewal not less than ninety (90) days prior to the expiration of the then effective term.
7. Terms for Breach. In the event any party fails to fulfill in a timely and proper manner its material obligations under this Agreement, which failure continues for thirty (30) days after written notice, the nonbreaching party (Client for a breach by Hospital or Hospital for a breach by Client) shall have the right to terminate this Agreement by giving a thirty (30) day written notice to the breaching party of such termination and specifying the date of the termination.
8. Documents Upon Termination. In the event of termination of this Agreement, all finished and unfinished documents prepared by Doctor under this Agreement shall become the property of JCC. Doctor shall not perform any new or additional work upon termination without the advance, written permission of JCC.
9. Entire Agreement: Amendments. This Agreement sets for the entire agreement among the parties hereto on the subject matter hereof. No understanding not set forth herein shall have any force or effect. This Agreement may be amended only by a written document signed by the parties.
10. Insurance. Doctor shall obtain and maintain the following insurance policies during the term of this Agreement with the minimum limits as specified.
 - i. Medical Malpractice: Medical professional liability insurance insuring Hospital and Medical Director, professional liability coverage for Physician for services performed under this Agreement in an amount not less than One Million Dollars (\$1,000,000) and Three Million Dollars (\$3,000,000) aggregate through an insurance company authorized to do business in Nebraska and in accordance with the provisions of Nebraska Statutes, covering medical malpractice.

11. Assignment and Subcontract Prohibited. No party may assign or subcontract any interest or obligation under this Agreement without the prior written approval shall not be unreasonably withheld.
12. Severability. It is agreed that in case any provision of this Agreement is determined by any court of law to be unconstitutional, illegal, or unenforceable, it is the intention of the parties that all other provisions of this Agreement remain in full force and effect.
13. Nondiscrimination. In the performance of work under this Agreement, the parties agree not to discriminate against any employee or applicant for employment in violation of any Federal, State, or Local law, rule or regulation because of race, religion, marital status, age, creed, color, sex, handicap, national origin, or ancestry, sexual orientation, income level or source of income, arrest record or conviction record, less than honorable discharge, physical appearance, sexual orientation, political beliefs, or student status. Services are to be provided in accordance with the Federal Americans with Disabilities Act to the extent applicable.
14. Governing Law. This agreement shall be deemed to have been made in Nebraska and shall be construed and interpreted in accordance with the laws of the State of Nebraska without giving effect to the choice of law provisions thereof. The jurisdiction and venue for any dispute hereunder shall be in the federal or state courts in Nebraska. No party shall commence an action in any other venue or forum. All parties waive trial by jury in any action or proceeding hereunder or relating hereto.
15. No Waiver. No failure to exercise, or delay in exercising, any right, power to remedy hereunder on the part of a party shall operate as a waiver thereof, nor shall any single or partial exercise of any other right, power or remedy preclude any other further exercise thereof or the exercise of any other right, power or remedy. No express waiver shall affect any event of default other than the event of default specified in such waiver, and any such waiver, to be effective, must be in writing and shall be operative only for the time and to the extent expressly provided therein. A waiver of any covenant, term or condition contained herein shall not be construed as a waiver of any subsequent breach of the same covenant, term or condition.
16. Notices. The parties hereto expressly agree for the purposes of notice, including legal service of process during the term of this Agreement and for the period of any applicable statutes of limitations thereafter, the following named individuals shall be the authorized representatives of the parties:

THE CITY OF COLUMBUS, NEBRASKA
Attn: City Administrator
2424 14th St.
Columbus, NE 68601
(402) 562-4233

THE COUNTY OF PLATTE, NEBRASKA
Attn: County Clerk
2610 14th Street
Columbus, Nebraska 68601
(402) 563-4904

COLUMBUS/PLATTE COUNTY
JOINT COMMUNITICAITONS
CENTER
Attn: Communications Director
2424 14th St
Columbus, NE 68601
(402) 564-3201

DOCTOR MARK HOWERTER
4826 37th St
Columbus, NE 68601
(402) 270-3922

All notices, requests, demands or other communications under this Agreement shall be in writing and shall be deemed to have been given the date of service if served personally on the party to whom notice is given or on the third (3rd) day after mailing if mailed to the party to whom notice is to be given, by first class mail, registered or certified, postage prepaid and properly addressed as shown above.

17. No Third-Party Beneficiaries. This Agreement is intended to be solely among the parties hereto. No part of this Agreement shall be construed to add, supplement, amend, abridge or repeal existing rights, benefits, or privileges of any third party or parties, including but not limited to, employees of a party.
18. Singulars / Plurals / Context. Whenever required by the context, the singular shall include the plural, the plural the singular, and one gender shall include all genders. When not inconsistent with the context, words used in the present tense include the future. The words “shall” and “will” are mandatory, and the word “may” is permissive.
19. Caption Headings. The Caption Headings in this Agreement are for convenience only and are not to be used to interpret or define the provisions of the Agreement.
20. Agreement Authorized. As of the effective date of this Agreement, each party represents and warrants to the others that the execution and performance by it of this Agreement has been duly authorized by all necessary actions and constitutes its valid and legally binding obligation and is legally enforceable.
21. Counterparts. This Agreement may be executed in one or more counterparts, each of which shall be deemed to be an original, but all of which together shall constitute one in the same instrument.

IN WITNESS WHEREOF, the parties hereto hereby execute this Agreement, through representatives having legal authority to bind them, on the dates below given.

****Remainder of page left intentionally blank****

Executed and Adopted this _____ day of _____, 2023, by the City of Columbus, Nebraska:

ATTEST:

THE CITY OF COLUMBUS,
NEBRASKA:

City Clerk

Mayor

Executed and Adopted this _____ day of _____, 2023, by the County of Platte, Nebraska:

ATTEST:

THE COUNTY OF PLATTE,
NEBRASKA:

County Clerk

Chairman

Executed and Adopted this _____ day of _____, 2023, by the Doctor Mark S. Howerter:

Mark S. Howerter

Acknowledged this _____ day of _____, 2023, by the Columbus/Platte County Joint Communications Center:

COLUMBUS/PLATTE COUNTY
JOINT COMMUNICATIONS
CENTER

Director

APPROVED AS TO FORM:

Columbus City Attorney (Date)

Platte County
Attorney (Date)

14.B. Resolution No. R23-77 approving a grant agreement with Federal Aviation Administration for Fiscal Year 2023 Airport Improvement Program.

Draft

RESOLUTION NO. R23-77

A RESOLUTION OF THE MAYOR AND COUNCIL OF THE CITY OF COLUMBUS, NEBRASKA, APPROVING A GRANT AGREEMENT WITH FEDERAL AVIATION ADMINISTRATION FOR FISCAL YEAR 2023 AIRPORT IMPROVEMENT PROGRAM (GRANT NO. 3-31-0019-017-2023), A COPY OF WHICH IS ATTACHED HERETO AND INCORPORATED HEREIN BY THIS REFERENCE; TO AUTHORIZE THE MAYOR TO EXECUTE THE SAME ON BEHALF OF THE CITY; AND TO REPEAL ALL RESOLUTIONS OR PORTIONS THEREOF IN CONFLICT HEREWITH.

WHEREAS, via Resolution No. R23-35 the City approved an Agency Agreement with the Department of Transportation, Aeronautics Division for Grant No. 3-31-0019-017-2023 for purposes of obtaining federal assistance for the Columbus Municipal Airport; and

WHEREAS, a grant offer and agreement for the Airport Improvement Program (AIP) Project No. 3-31-0019-017-2023 has been developed, prepared, and submitted to the City for execution.

NOW, THEREFORE, BE IT RESOLVED BY THE MAYOR AND COUNCIL OF CITY OF COLUMBUS, NEBRASKA, that the grant agreement with Federal Aviation Administration for Fiscal Year 2023 Airport Improvement Program (Grant No. 3-31-0019-017-2023), a copy of which is attached hereto and incorporated herein by this reference, is hereby approved and the mayor is authorized, directed, and empowered to execute the same on behalf of the City of Columbus.

This resolution shall repeal all resolutions or portions thereof in conflict herewith.

INTRODUCED BY COUNCIL MEMBER _____

PASSED AND ADOPTED THIS ____ DAY OF _____, 2023.

MAYOR

ATTEST:

CITY CLERK

APPROVED AS TO FORM:

CITY ATTORNEY



U.S. Department
of Transportation
**Federal Aviation
Administration**

Airports Division
Central Region
Iowa, Kansas, Missouri, Nebraska

FAA ACE-600
901 Locust
Kansas City, MO 64106

Ms. Anna Lannin, P.E.
Planning and Programming
Nebraska Department of Transportation Division of Aeronautics
3431 Aviation Rd, Suite 150
Lincoln, NE 68501

Dear Ms. Lannin:

The Grant Offer for Airport Improvement Program (AIP) Project No. 3-31-0019-017-2023 at Columbus Municipal Airport is attached for execution. This letter outlines the steps you must take to properly enter into this agreement and provides other useful information. Please read the conditions, special conditions, and assurances that comprise the grant offer carefully.

You may not make any modification to the text, terms or conditions of the grant offer.

Steps You Must Take to Enter Into Agreement. To properly enter into this agreement, you must do the following:

1. The governing body must give authority to execute the grant to the individual(s) signing the grant, i.e., the person signing the document must be the sponsor's authorized representative(s) (hereinafter "authorized representative").
2. The authorized representative must execute the grant by adding their electronic signature to the appropriate certificate at the end of the agreement.
3. Once the authorized representative has electronically signed the grant, the sponsor's attorney(s) will automatically receive an email notification.
4. On the **same day or after** the authorized representative has signed the grant, the sponsor's attorney(s) will add their electronic signature to the appropriate certificate at the end of the agreement.
5. If there are co-sponsors, the authorized representative(s) and sponsor's attorney(s) must follow the above procedures to fully execute the grant and finalize the process. Signatures must be obtained and finalized no later than July 7, 2023.
6. The fully executed grant will then be automatically sent to all parties as an email attachment.

Payment. Subject to the requirements in 2 CFR § 200.305 (Federal Payment), each payment request for reimbursement under this grant must be made electronically via the Delphi eInvoicing System. Please see the attached Grant Agreement for more information regarding the use of this System.

Project Timing. The terms and conditions of this agreement require you to complete the project without undue delay and no later than the Period of Performance end date (1,460 days from the grant execution date). We will be monitoring your progress to ensure proper stewardship of these Federal funds. We expect you to submit payment requests for reimbursement of allowable incurred project expenses consistent with project progress. Your grant may be placed in "inactive" status if you do not make draws

on a regular basis, which will affect your ability to receive future grant offers. Costs incurred after the Period of Performance ends are generally not allowable and will be rejected unless authorized by the FAA in advance.

Reporting. Until the grant is completed and closed, you are responsible for submitting formal reports as follows:

- For all grants, you must submit by December 31st of each year this grant is open:
 1. A signed/dated SF-270 (Request for Advance or Reimbursement for non-construction projects) or SF-271 or equivalent (Outlay Report and Request for Reimbursement for Construction Programs), and
 2. An SF-425 (Federal Financial Report).
- For non-construction projects, you must submit [FAA Form 5100-140, Performance Report](#) within 30 days of the end of the Federal fiscal year.
- For construction projects, you must submit [FAA Form 5370-1, Construction Progress and Inspection Report](#), within 30 days of the end of each Federal fiscal quarter.

Audit Requirements. As a condition of receiving Federal assistance under this award, you must comply with audit requirements as established under 2 CFR Part 200. Subpart F requires non-Federal entities that expend \$750,000 or more in Federal awards to conduct a single or program specific audit for that year. Note that this includes Federal expenditures made under other Federal-assistance programs. Please take appropriate and necessary action to ensure your organization will comply with applicable audit requirements and standards.

Closeout. Once the project(s) is completed and all costs are determined, we ask that you work with your FAA contact indicated below to close the project without delay and submit the necessary final closeout documentation as required by your Region/Airports District Office.

FAA Contact Information. Andrea McKinnie, (816) 329-2633, is the assigned program manager for this grant and is readily available to assist you and your designated representative with the requirements stated herein.

We sincerely value your cooperation in these efforts and look forward to working with you to complete this important project.

Sincerely,

Jim A. Johnson

Director, Central Region Airports Division



U.S. Department
of Transportation
Federal Aviation
Administration

FEDERAL AVIATION ADMINISTRATION AIRPORT IMPROVEMENT PROGRAM

FY 2023 AIRPORT IMPROVEMENT PROGRAM (AIP)

GRANT AGREEMENT

Part I - Offer

Federal Award Offer Date	May 23, 2023
Airport/Planning Area	Columbus Municipal
AIP Grant Number	3-31-0019-017-2023
Unique Entity Identifier	YM4RJGN196F5

TO: **City of Columbus, Nebraska**
(herein called the "Sponsor") (For Co-Sponsors, list all Co-Sponsor names. The word "Sponsor" in this Grant Agreement also applies to a Co-Sponsor.)

FROM: **The United States of America** (acting through the Federal Aviation Administration, herein called the "FAA")

WHEREAS, the Sponsor has submitted to the FAA a Project Application dated **February 21, 2023**, for a grant of Federal funds for a project at or associated with the **Columbus Municipal Airport**, which is included as part of this Grant Agreement; and

WHEREAS, the FAA has approved a project for the **Columbus Municipal Airport** (herein called the "Project") consisting of the following:

Construct an 8-place T-Hangar - Design Only

which is more fully described in the Project Application.

NOW THEREFORE, Pursuant to and for the purpose of carrying out the Title 49, United States Code (U.S.C.), Chapters 471 and 475; 49 U.S.C. §§ 40101 et seq., and 48103; FAA Reauthorization Act of 2018 (Public Law Number 115-254); the Department of Transportation Appropriations Act, 2021 (Public Law 116-260, Division L); the Consolidated Appropriations Act, 2022 (Public Law 117-103); Consolidated Appropriations Act, 2023 (Public Law 117-328); and the representations contained in the Project Application; and in consideration of: (a) the Sponsor’s adoption and ratification of the Grant Assurances attached hereto; (b) the Sponsor’s acceptance of this Offer; and (c) the benefits to accrue to the United

States and the public from the accomplishment of the Project and compliance with the Grant Assurance and conditions as herein provided;

THE FEDERAL AVIATION ADMINISTRATION, FOR AND ON BEHALF OF THE UNITED STATES, HEREBY OFFERS AND AGREES to pay Ninety (90%) of the allowable costs incurred accomplishing the Project as the United States share of the Project.

Assistance Listings Number (Formerly CFDA Number): 20.106

This Offer is made on and SUBJECT TO THE FOLLOWING TERMS AND CONDITIONS:

CONDITIONS

1. **Maximum Obligation.** The maximum obligation of the United States payable under this Offer is \$134,100.00.

The following amounts represent a breakdown of the maximum obligation for the purpose of establishing allowable amounts for any future grant amendment, which may increase the foregoing maximum obligation of the United States under the provisions of 49 U.S.C. § 47108(b):

\$0 for planning

\$134,100.00 for airport development or noise program implementation; and,

\$0 for land acquisition.

2. **Grant Performance.** This Grant Agreement is subject to the following Federal award requirements:

- a. Period of Performance:

1. Shall start on the date the Sponsor formally accepts this Agreement and is the date signed by the last Sponsor signatory to the Agreement. The end date of the Period of Performance is 4 years (1,460 calendar days) from the date of acceptance. The Period of Performance end date shall not affect, relieve, or reduce Sponsor obligations and assurances that extend beyond the closeout of this Grant Agreement.
2. Means the total estimated time interval between the start of an initial Federal award and the planned end date, which may include one or more funded portions or budget periods (2 Code of Federal Regulations (CFR) § 200.1).

- b. Budget Period:

1. For this Grant is 4 years (1,460 calendar days) and follows the same start and end date as the Period of Performance provided in paragraph (2)(a)(1). Pursuant to 2 CFR § 200.403(h), the Sponsor may charge to the Grant only allowable costs incurred during the Budget Period.
2. Means the time interval from the start date of a funded portion of an award to the end date of that funded portion during which the Sponsor is authorized to expend the funds awarded, including any funds carried forward or other revisions pursuant to 2 CFR § 200.308.

- c. Close Out and Termination:

1. Unless the FAA authorizes a written extension, the Sponsor must submit all Grant closeout documentation and liquidate (pay-off) all obligations incurred under this award no later than 120 calendar days after the end date of the period of performance. If the Sponsor does not submit all required closeout documentation within this time period, the FAA will

proceed to close out the grant within one year of the Period of Performance end date with the information available at the end of 120 days. (2 CFR § 200.344).

2. The FAA may terminate this Grant, in whole or in part, in accordance with the conditions set forth in 2 CFR § 200.340, or other Federal regulatory or statutory authorities as applicable.
3. **Ineligible or Unallowable Costs.** The Sponsor must not include any costs in the project that the FAA has determined to be ineligible or unallowable.
4. **Indirect Costs - Sponsor.** The Sponsor may charge indirect costs under this award by applying the indirect cost rate identified in the project application as accepted by the FAA, to allowable costs for Sponsor direct salaries and wages.
5. **Determining the Final Federal Share of Costs.** The United States' share of allowable project costs will be made in accordance with 49 U.S.C. § 47109, the regulations, policies, and procedures of the Secretary of Transportation ("Secretary"), and any superseding legislation. Final determination of the United States' share will be based upon the final audit of the total amount of allowable project costs and settlement will be made for any upward or downward adjustments to the Federal share of costs.
6. **Completing the Project Without Delay and in Conformance with Requirements.** The Sponsor must carry out and complete the project without undue delays and in accordance with this Agreement, 49 U.S.C. Chapters 471 and 475, the regulations, and the Secretary's policies and procedures. Per 2 CFR § 200.308, the Sponsor agrees to report and request prior FAA approval for any disengagement from performing the project that exceeds three months or a 25 percent reduction in time devoted to the project. The report must include a reason for the project stoppage. The Sponsor also agrees to comply with the grant assurances, which are part of this Agreement.
7. **Amendments or Withdrawals before Grant Acceptance.** The FAA reserves the right to amend or withdraw this offer at any time prior to its acceptance by the Sponsor.
8. **Offer Expiration Date.** This offer will expire and the United States will not be obligated to pay any part of the costs of the project unless this offer has been accepted by the Sponsor on or before July 7, 2023, or such subsequent date as may be prescribed in writing by the FAA.
9. **Improper Use of Federal Funds.** The Sponsor must take all steps, including litigation if necessary, to recover Federal funds spent fraudulently, wastefully, or in violation of Federal antitrust statutes, or misused in any other manner for any project upon which Federal funds have been expended. For the purposes of this Grant Agreement, the term "Federal funds" means funds however used or dispersed by the Sponsor, that were originally paid pursuant to this or any other Federal grant agreement. The Sponsor must obtain the approval of the Secretary as to any determination of the amount of the Federal share of such funds. The Sponsor must return the recovered Federal share, including funds recovered by settlement, order, or judgment, to the Secretary. The Sponsor must furnish to the Secretary, upon request, all documents and records pertaining to the determination of the amount of the Federal share or to any settlement, litigation, negotiation, or other efforts taken to recover such funds. All settlements or other final positions of the Sponsor, in court or otherwise, involving the recovery of such Federal share require advance approval by the Secretary.
10. **United States Not Liable for Damage or Injury.** The United States is not responsible or liable for damage to property or injury to persons which may arise from, or be incident to, compliance with this Grant Agreement.

11. System for Award Management (SAM) Registration and Unique Entity Identifier (UEI).

- a. Requirement for System for Award Management (SAM): Unless the Sponsor is exempted from this requirement under 2 CFR § 25.110, the Sponsor must maintain the currency of its information in the SAM until the Sponsor submits the final financial report required under this Grant, or receives the final payment, whichever is later. This requires that the Sponsor review and update the information at least annually after the initial registration and more frequently if required by changes in information or another award term. Additional information about registration procedures may be found at the SAM website (currently at <http://www.sam.gov>).
- b. Unique entity identifier (UEI) means a 12-character alpha-numeric value used to identify a specific commercial, nonprofit or governmental entity. A UEI may be obtained from SAM.gov at <https://sam.gov/content/entity-registration>.

12. **Electronic Grant Payment(s).** Unless otherwise directed by the FAA, the Sponsor must make each payment request under this Agreement electronically via the Delphi eInvoicing System for Department of Transportation (DOT) Financial Assistance Awardees.

13. **Informal Letter Amendment of AIP Projects.** If, during the life of the project, the FAA determines that the maximum grant obligation of the United States exceeds the expected needs of the Sponsor by \$25,000 or five percent (5%), whichever is greater, the FAA can issue a letter amendment to the Sponsor unilaterally reducing the maximum obligation.

The FAA can also issue a letter to the Sponsor increasing the maximum obligation if there is an overrun in the total actual eligible and allowable project costs to cover the amount of the overrun provided it will not exceed the statutory limitations for grant amendments. The FAA's authority to increase the maximum obligation does not apply to the "planning" component of Condition No. 1, Maximum Obligation.

The FAA can also issue an informal letter amendment that modifies the grant description to correct administrative errors or to delete work items if the FAA finds it advantageous and in the best interests of the United States.

An informal letter amendment has the same force and effect as a formal grant amendment.

14. **Air and Water Quality.** The Sponsor is required to comply with all applicable air and water quality standards for all projects in this grant. If the Sponsor fails to comply with this requirement, the FAA may suspend, cancel, or terminate this Grant Agreement.

15. **Financial Reporting and Payment Requirements.** The Sponsor will comply with all Federal financial reporting requirements and payment requirements, including submittal of timely and accurate reports.

16. **Buy American.** Unless otherwise approved in advance by the FAA, in accordance with 49 U.S.C. § 50101, the Sponsor will not acquire or permit any contractor or subcontractor to acquire any steel or manufactured products produced outside the United States to be used for any project for which funds are provided under this Grant. The Sponsor will include a provision implementing Buy American in every contract and subcontract awarded under this Grant.

17. **Build America, Buy America.** The Sponsor must comply with the requirements under the Build America, Buy America Act (Public Law 117-58).

18. **Maximum Obligation Increase.** In accordance with 49 U.S.C. § 47108(b)(3), as amended, the maximum obligation of the United States, as stated in Condition No. 1, Maximum Obligation, of this Grant Offer:

- a. May not be increased for a planning project;
- b. May be increased by not more than 15 percent for development projects if funds are available;
- c. May be increased by not more than the greater of the following for a land project, if funds are available:
 1. 15 percent; or
 2. 25 percent of the total increase in allowable project costs attributable to acquiring an interest in the land.

If the Sponsor requests an increase, any eligible increase in funding will be subject to the United States Government share as provided in 49 U.S.C. § 47110, or other superseding legislation if applicable, for the fiscal year appropriation with which the increase is funded. The FAA is not responsible for the same Federal share provided herein for any amount increased over the initial grant amount. The FAA may adjust the Federal share as applicable through an informal letter of amendment.

19. **Audits for Sponsors.**

The Sponsor must provide for a Single Audit or program-specific audit in accordance with 2 CFR Part 200. The Sponsor must submit the audit reporting package to the Federal Audit Clearinghouse on the Federal Audit Clearinghouse's Internet Data Entry System at <http://harvester.census.gov/facweb/>. Upon request of the FAA, the Sponsor shall provide one copy of the completed audit to the FAA. Sponsors that expend less than \$750,000 in Federal awards and are exempt from Federal audit requirements must make records available for review or audit by the appropriate Federal agency officials, State, and Government Accountability Office. The FAA and other appropriate Federal agencies may request additional information to meet all Federal audit requirements.

20. **Suspension or Debarment.** When entering into a "covered transaction" as defined by 2 CFR § 180.200, the Sponsor must:

- a. Verify the non-Federal entity is eligible to participate in this Federal program by:
 1. Checking the excluded parties list system (EPLS) as maintained within the System for Award Management (SAM) to determine if the non-Federal entity is excluded or disqualified; or
 2. Collecting a certification statement from the non-Federal entity attesting they are not excluded or disqualified from participating; or
 3. Adding a clause or condition to covered transactions attesting the individual or firm are not excluded or disqualified from participating.
- b. Require prime contractors to comply with 2 CFR § 180.330 when entering into lower-tier transactions (e.g., sub-contracts).
- c. Immediately disclose in writing to the FAA whenever (1) the Sponsor learns they have entered into a covered transaction with an ineligible entity or (2) the Public Sponsor suspends or debars a contractor, person, or entity.

21. Ban on Texting While Driving.

- a. In accordance with Executive Order 13513, Federal Leadership on Reducing Text Messaging While Driving, October 1, 2009, and DOT Order 3902.10, Text Messaging While Driving, December 30, 2009, the Sponsor is encouraged to:
 1. Adopt and enforce workplace safety policies to decrease crashes caused by distracted drivers including policies to ban text messaging while driving when performing any work for, or on behalf of, the Federal government, including work relating to a grant or subgrant.
 2. Conduct workplace safety initiatives in a manner commensurate with the size of the business, such as:
 - i. Establishment of new rules and programs or re-evaluation of existing programs to prohibit text messaging while driving; and
 - ii. Education, awareness, and other outreach to employees about the safety risks associated with texting while driving.
- b. The Sponsor must insert the substance of this clause on banning texting while driving in all subgrants, contracts, and subcontracts funded with this Grant.

22. Trafficking in Persons.

- a. *Provisions applicable to a recipient that is a private entity.*
 1. You as the recipient, your employees, subrecipients under this Grant, and subrecipients' employees may not:
 - i. Engage in severe forms of trafficking in persons during the period of time that the Grant and applicable conditions are in effect;
 - ii. Procure a commercial sex act during the period of time that the Grant and applicable conditions are in effect; or
 - iii. Use forced labor in the performance of the Grant or any subgrants under this Grant.
 2. We as the Federal awarding agency, may unilaterally terminate this Grant, without penalty, if you or a subrecipient that is a private entity –
 - i. Is determined to have violated a prohibition in paragraph (a) of this Grant Condition; or
 - ii. Has an employee who is determined by the agency official authorized to terminate the Grant to have violated a prohibition in paragraph (a) of this Grant Condition through conduct that is either –
 - a) Associated with performance under this Grant; or
 - b) Imputed to you or the subrecipient using the standards and due process for imputing the conduct of an individual to an organization that are provided in 2 CFR Part 180, "OMB Guidelines to Agencies on Governmentwide Debarment and Suspension (Nonprocurement)," as implemented by our agency at 2 CFR Part 1200.
- b. *Provision applicable to a recipient other than a private entity.* We as the Federal awarding agency may unilaterally terminate this Grant, without penalty, if a subrecipient that is a private entity –

1. Is determined to have violated an applicable prohibition in paragraph (a) of this Grant Condition; or
 2. Has an employee who is determined by the agency official authorized to terminate the Grant to have violated an applicable prohibition in paragraph (a) of this Grant Condition through conduct that is either –
 - i. Associated with performance under this Grant; or
 - ii. Imputed to the subrecipient using the standards and due process for imputing the conduct of an individual to an organization that are provided in 2 CFR Part 180, “OMB Guidelines to Agencies on Governmentwide Debarment and Suspension (Nonprocurement),” as implemented by our agency at 2 CFR Part 1200.
- c. *Provisions applicable to any recipient.*
1. You must inform us immediately of any information you receive from any source alleging a violation of a prohibition in paragraph (a) of this Grant Condition.
 2. Our right to terminate unilaterally that is described in paragraph (a) or (b) of this Grant Condition:
 - i. Implements section 106(g) of the Trafficking Victims Protection Act of 2000 (TVPA), as amended [22 U.S.C. § 7104(g)], and
 - ii. Is in addition to all other remedies for noncompliance that are available to us under this Grant.
 3. You must include the requirements of paragraph (a) of this Grant Condition in any subgrant you make to a private entity.
- d. *Definitions.* For purposes of this Grant Condition:
1. “Employee” means either:
 - i. An individual employed by you or a subrecipient who is engaged in the performance of the project or program under this Grant; or
 - ii. Another person engaged in the performance of the project or program under this Grant and not compensated by you including, but not limited to, a volunteer or individual whose services are contributed by a third party as an in-kind contribution toward cost sharing or matching requirements.
 2. “Force labor” means labor obtained by any of the following methods: the recruitment, harboring, transportation, provision, or obtaining of a person for labor or services, through the use of force, fraud, or coercion for the purpose of subjection to involuntary servitude, peonage, debt bondage, or slavery.
 3. “Private entity”:
 - i. Means any entity other than a State, local government, Indian tribe, or foreign public entity, as those terms are defined in 2 CFR § 175.25.
 - ii. Includes:
 - a) A nonprofit organization, including any nonprofit institute of higher education, hospital, or tribal organization other than one included in the definition of Indian tribe at 2 CFR § 175.25(b).

b) A for-profit organization.

4. "Severe forms of trafficking in persons," "commercial sex act," and "coercion" have the meanings given at section 103 of the TVPA, as amended (22 U.S.C. § 7102).
23. **AIP Funded Work Included in a PFC Application.** Within 90 days of acceptance of this Grant Agreement, the Sponsor must submit to the FAA an amendment to any approved Passenger Facility Charge (PFC) application that contains an approved PFC project also covered under this Grant Agreement as described in the project application. The airport sponsor may not make any expenditure under this Grant Agreement until project work addressed under this Grant Agreement is removed from an approved PFC application by amendment.
 24. **Exhibit "A" Property Map.** The Exhibit "A" Property Map dated May 05, 2015, is incorporated herein by reference or is submitted with the project application and made part of this Grant Agreement.
 25. **Employee Protection from Reprisal.**
 - a. Prohibition of Reprisals.
 1. In accordance with 41 U.S.C. § 4712, an employee of a Sponsor, grantee, subgrantee, contractor, or subcontractor may not be discharged, demoted, or otherwise discriminated against as a reprisal for disclosing to a person or body described in sub-paragraph (a)(2) below, information that the employee reasonably believes is evidence of:
 - i. Gross mismanagement of a Federal grant;
 - ii. Gross waste of Federal funds;
 - iii. An abuse of authority relating to implementation or use of Federal funds;
 - iv. A substantial and specific danger to public health or safety; or
 - v. A violation of law, rule, or regulation related to a Federal grant.
 2. Persons and bodies covered. The persons and bodies to which a disclosure by an employee is covered are as follows:
 - i. A member of Congress or a representative of a committee of Congress;
 - ii. An Inspector General;
 - iii. The Government Accountability Office;
 - iv. A Federal employee responsible for contract or grant oversight or management at the relevant agency;
 - v. A court or grand jury;
 - vi. A management official or other employee of the Sponsor, contractor, or subcontractor who has the responsibility to investigate, discover, or address misconduct; or
 - vii. An authorized official of the Department of Justice or other law enforcement agency.
 - b. Investigation of Complaints.
 1. Submission of Complaint. A person who believes that they have been subjected to a reprisal prohibited by paragraph (a) of this Condition may submit a complaint regarding the reprisal to the Office of Inspector General (OIG) for the U.S. Department of Transportation.

2. Time Limitation for Submittal of a Complaint. A complaint may not be brought under this subsection more than three years after the date on which the alleged reprisal took place.
 3. Required Actions of the Inspector General. Actions, limitations, and exceptions of the Inspector General's office are established under 41 U.S.C. § 4712(b).
- c. Remedy and Enforcement Authority.
1. Assumption of Rights to Civil Remedy. Upon receipt of an explanation of a decision not to conduct or continue an investigation by the OIG, the person submitting a complaint assumes the right to a civil remedy under 41 U.S.C. § 4712(c)(2).
26. **Co-Sponsor.** Co-Sponsors, if any, understand and agree that they jointly and severally adopt and ratify the representations and assurances contained therein and that the word "Sponsor" as used in the application and other assurances is deemed to include all Co-Sponsors.
27. **Prohibited Telecommunications and Video Surveillance Services and Equipment.** The Sponsor agrees to comply with mandatory standards and policies relating to use and procurement of certain telecommunications and video surveillance services or equipment in compliance with the National Defense Authorization Act [Public Law 115-232 § 889(f)(1)] and 2 CFR § 200.216.
28. **Critical Infrastructure Security and Resilience.** The Sponsor acknowledges that it has considered and addressed physical and cybersecurity and resilience in their project planning, design, and oversight, as determined by the DOT and the Department of Homeland Security.

SPECIAL CONDITIONS

29. **Protection of Runway Protection Zone - Airport Property.** The Sponsor agrees to prevent the erection or creation of any structure, place of public assembly, or other use in the Runway Protection Zone, as depicted on the Exhibit "A": Property Map, except for Navigational Aids (NAVAIDS) that are fixed by their functional purposes or any other structure permitted by the FAA. The Sponsor further agrees that any existing structures or uses within the Runway Protection Zone will be cleared or discontinued by the Sponsor unless approved by the FAA.
30. **Protection of Runway Protection Zone - Easement.** The Sponsor, under the easement, agrees to take any and all steps necessary to ensure that the owner of the land within the designated Runway Protection Zone will not build any structure in the Runway Protection Zone that is an airport hazard or which might create glare or misleading lights or lead to the construction of residences, fuel handling and storage facilities, smoke generating activities, or places of public assembly, such as churches, schools, office buildings, shopping centers, and stadiums.
31. **Design Grant.** This Grant Agreement is being issued in order to complete the design of the project. The Sponsor understands and agrees that within 2 years after the design is completed that the Sponsor will accept, subject to the availability of the amount of Federal funding identified in the Airport Capital Improvement Plan (ACIP), a grant to complete the construction of the project in order to provide a useful and useable unit of work. The Sponsor also understands that if the FAA has provided Federal funding to complete the design for the project, and the Sponsor has not completed the design within four (4) years from the execution of this Grant Agreement, the FAA may suspend or terminate grants related to the design.
32. **Revenue Producing Project.** The Sponsor agrees and understands that the Sponsor has certified to the FAA that it has made adequate provisions for financing its airside needs. Further, the Sponsor agrees it will not seek AIP discretionary grant funds for the airside needs of the airport for the two fiscal years following the fiscal year in which this Grant is issued. All revenue generated by this

project must be used for the operation and maintenance of the Airport in accordance with the Grant Assurances, 49 U.S.C. § 47133, and FAA's Policy and Procedures Concerning the Use of Airport Revenue (64 FR 7696, as amended).

33. **Buy American Executive Orders.** The Sponsor agrees to abide by applicable Executive Orders in effect at the time this Grant Agreement is executed, including Executive Order 14005, Ensuring the Future Is Made in All of America by All of America's Workers.
34. **Agency Agreement:** The FAA in tendering this offer on behalf of the United States recognizes the existence of an agency relationship between the **City of Columbus, Nebraska**, as principal, and the Nebraska Department of Transportation, Aeronautics Division, as agent, created by the Agency Agreement entered into on **February 21, 2023**. The Sponsor agrees that it will not amend, modify or terminate said Agency Agreement without prior approval in writing of the FAA.

The Sponsor's acceptance of this Offer and ratification and adoption of the Project Application incorporated herein shall be evidenced by execution of this instrument by the Sponsor, as hereinafter provided, and this Offer and Acceptance shall comprise a Grant Agreement, constituting the contractual obligations and rights of the United States and the Sponsor with respect to the accomplishment of the Project and compliance with the Grant Assurances, terms, and conditions as provided herein. Such Grant Agreement shall become effective upon the Sponsor's acceptance of this Offer.

Please read the following information: By signing this document, you are agreeing that you have reviewed the following consumer disclosure information and consent to transact business using electronic communications, to receive notices and disclosures electronically, and to utilize electronic signatures in lieu of using paper documents. You are not required to receive notices and disclosures or sign documents electronically. If you prefer not to do so, you may request to receive paper copies and withdraw your consent at any time.

I declare under penalty of perjury that the foregoing is true and correct.¹

**UNITED STATES OF AMERICA
FEDERAL AVIATION ADMINISTRATION**

Jim A. Johnson

(Signature)

Jim A. Johnson

(Typed Name)

Director, Central Region Airports Division

(Title of FAA Official)

¹ Knowingly and willfully providing false information to the Federal government is a violation of 18 U.S.C. § 1001 (False Statements) and could subject you to fines, imprisonment, or both.

PART II - ACCEPTANCE

The Sponsor does hereby ratify and adopt all assurances, statements, representations, warranties, covenants, and agreements contained in the Project Application and incorporated materials referred to in the foregoing Offer, and does hereby accept this Offer and by such acceptance agrees to comply with all of the Grant Assurances, terms, and conditions in this Offer and in the Project Application.

Please read the following information: By signing this document, you are agreeing that you have reviewed the following consumer disclosure information and consent to transact business using electronic communications, to receive notices and disclosures electronically, and to utilize electronic signatures in lieu of using paper documents. You are not required to receive notices and disclosures or sign documents electronically. If you prefer not to do so, you may request to receive paper copies and withdraw your consent at any time.

I declare under penalty of perjury that the foregoing is true and correct.²

Dated May 26, 2023

City of Columbus, Nebraska

(Name of Sponsor)

 (May 26, 2023 15:40 CDT)

(Signature of Sponsor's Authorized Official)

By: James B Bulkley

(Typed Name of Sponsor's Authorized Official)

Title: Mayor

(Title of Sponsor's Authorized Official)

² Knowingly and willfully providing false information to the Federal government is a violation of 18 U.S.C. § 1001 (False Statements) and could subject you to fines, imprisonment, or both.

CERTIFICATE OF SPONSOR’S ATTORNEY

I, _____, acting as Attorney for the Sponsor do hereby certify:

That in my opinion the Sponsor is empowered to enter into the foregoing Grant Agreement under the laws of the State of Nebraska. Further, I have examined the foregoing Grant Agreement and the actions taken by said Sponsor and Sponsor’s official representative, who has been duly authorized to execute this Grant Agreement, which is in all respects due and proper and in accordance with the laws of the said State; the Infrastructure Investment and Jobs Act (Public Law 117-58) of 2021 referred to as the Bipartisan Infrastructure Law (BIL), Division J, Title VIII; and the representations contained in the Project Application. In addition, for grants involving projects to be carried out on property not owned by the Sponsor, there are no legal impediments that will prevent full performance by the Sponsor. Further, it is my opinion that the said Grant Agreement constitutes a legal and binding obligation of the Sponsor in accordance with the terms thereof.

Please read the following information: By signing this document, you are agreeing that you have reviewed the following consumer disclosure information and consent to transact business using electronic communications, to receive notices and disclosures electronically, and to utilize electronic signatures in lieu of using paper documents. You are not required to receive notices and disclosures or sign documents electronically. If you prefer not to do so, you may request to receive paper copies and withdraw your consent at any time.

I declare under penalty of perjury that the foregoing is true and correct.³

Dated at _____

By:

(Signature of Sponsor’s Attorney)

³ Knowingly and willfully providing false information to the Federal government is a violation of 18 U.S.C. § 1001 (False Statements) and could subject you to fines, imprisonment, or both.

ASSURANCES

AIRPORT SPONSORS

A. General.

1. These assurances shall be complied with in the performance of grant agreements for airport development, airport planning, and noise compatibility program grants for airport sponsors.
2. These assurances are required to be submitted as part of the project application by sponsors requesting funds under the provisions of Title 49, U.S.C., subtitle VII, as amended. As used herein, the term "public agency sponsor" means a public agency with control of a public-use airport; the term "private sponsor" means a private owner of a public-use airport; and the term "sponsor" includes both public agency sponsors and private sponsors.
3. Upon acceptance of this grant offer by the sponsor, these assurances are incorporated in and become part of this Grant Agreement.

B. Duration and Applicability.

1. **Airport development or Noise Compatibility Program Projects Undertaken by a Public Agency Sponsor.**

The terms, conditions and assurances of this Grant Agreement shall remain in full force and effect throughout the useful life of the facilities developed or equipment acquired for an airport development or noise compatibility program project, or throughout the useful life of the project items installed within a facility under a noise compatibility program project, but in any event not to exceed twenty (20) years from the date of acceptance of a grant offer of Federal funds for the project. However, there shall be no limit on the duration of the assurances regarding Exclusive Rights and Airport Revenue so long as the airport is used as an airport. There shall be no limit on the duration of the terms, conditions, and assurances with respect to real property acquired with federal funds. Furthermore, the duration of the Civil Rights assurance shall be specified in the assurances.

2. **Airport Development or Noise Compatibility Projects Undertaken by a Private Sponsor.**

The preceding paragraph (1) also applies to a private sponsor except that the useful life of project items installed within a facility or the useful life of the facilities developed or equipment acquired under an airport development or noise compatibility program project shall be no less than ten (10) years from the date of acceptance of Federal aid for the project.

3. **Airport Planning Undertaken by a Sponsor.**

Unless otherwise specified in this Grant Agreement, only Assurances 1, 2, 3, 5, 6, 13, 18, 23, 25, 30, 32, 33, 34, and 37 in Section C apply to planning projects. The terms, conditions, and assurances of this Grant Agreement shall remain in full force and effect during the life of the project; there shall be no limit on the duration of the assurances regarding Exclusive Rights and Airport Revenue so long as the airport is used as an airport.

C. Sponsor Certification.

The sponsor hereby assures and certifies, with respect to this grant that:

1. General Federal Requirements

It will comply with all applicable Federal laws, regulations, executive orders, policies, guidelines, and requirements as they relate to the application, acceptance, and use of Federal funds for this Grant including but not limited to the following:

FEDERAL LEGISLATION

- a. 49 U.S.C. subtitle VII, as amended.
- b. Davis-Bacon Act, as amended — 40 U.S.C. §§ 3141-3144, 3146, and 3147, et seq.¹
- c. Federal Fair Labor Standards Act – 29 U.S.C. § 201, et seq.
- d. Hatch Act – 5 U.S.C. § 1501, et seq.²
- e. Uniform Relocation Assistance and Real Property Acquisition Policies Act of 1970, 42 U.S.C. § 4601, et seq.^{1, 2}
- f. National Historic Preservation Act of 1966 – Section 106 – 54 U.S.C. § 306108.¹
- g. Archeological and Historic Preservation Act of 1974 – 54 U.S.C. § 312501, et seq.¹
- h. Native Americans Grave Repatriation Act – 25 U.S.C. § 3001, et seq.
- i. Clean Air Act, P.L. 90-148, as amended – 42 U.S.C. § 7401, et seq.
- j. Coastal Zone Management Act, P.L. 92-583, as amended – 16 U.S.C. § 1451, et seq.
- k. Flood Disaster Protection Act of 1973 – Section 102(a) - 42 U.S.C. § 4012a.¹
- l. 49 U.S.C. § 303, (formerly known as Section 4(f)).
- m. Rehabilitation Act of 1973 – 29 U.S.C. § 794.
- n. Title VI of the Civil Rights Act of 1964 (42 U.S.C. § 2000d et seq., 78 stat. 252) (prohibits discrimination on the basis of race, color, national origin).
- o. Americans with Disabilities Act of 1990, as amended, (42 U.S.C. § 12101 et seq.) (prohibits discrimination on the basis of disability).
- p. Age Discrimination Act of 1975 – 42 U.S.C. § 6101, et seq.
- q. American Indian Religious Freedom Act, P.L. 95-341, as amended.
- r. Architectural Barriers Act of 1968, as amended – 42 U.S.C. § 4151, et seq.¹
- s. Powerplant and Industrial Fuel Use Act of 1978 – Section 403 – 42 U.S.C. § 8373.¹
- t. Contract Work Hours and Safety Standards Act – 40 U.S.C. § 3701, et seq.¹
- u. Copeland Anti-kickback Act – 18 U.S.C. § 874.¹
- v. National Environmental Policy Act of 1969 – 42 U.S.C. § 4321, et seq.¹
- w. Wild and Scenic Rivers Act, P.L. 90-542, as amended – 16 U.S.C. § 1271, et seq.
- x. Single Audit Act of 1984 – 31 U.S.C. § 7501, et seq.²

- y. Drug-Free Workplace Act of 1988 – 41 U.S.C. §§ 8101 through 8105.
- z. The Federal Funding Accountability and Transparency Act of 2006, as amended (P.L. 109-282, as amended by section 6202 of P.L. 110-252).
- aa. Civil Rights Restoration Act of 1987, P.L. 100-259.
- bb. Build America, Buy America Act, P.L. 117-58, Title IX.

EXECUTIVE ORDERS

- a. Executive Order 11246 – Equal Employment Opportunity¹
- b. Executive Order 11990 – Protection of Wetlands
- c. Executive Order 11998 – Flood Plain Management
- d. Executive Order 12372 – Intergovernmental Review of Federal Programs
- e. Executive Order 12699 – Seismic Safety of Federal and Federally Assisted New Building Construction¹
- f. Executive Order 12898 – Environmental Justice
- g. Executive Order 13166 – Improving Access to Services for Persons with Limited English Proficiency
- h. Executive Order 13985 – Executive Order on Advancing Racial Equity and Support for Underserved Communities Through the Federal Government
- i. Executive Order 13988 – Preventing and Combating Discrimination on the Basis of Gender Identity or Sexual Orientation
- j. Executive Order 14005 – Ensuring the Future is Made in all of America by All of America’s Workers
- k. Executive Order 14008 – Tackling the Climate Crisis at Home and Abroad

FEDERAL REGULATIONS

- a. 2 CFR Part 180 – OMB Guidelines to Agencies on Governmentwide Debarment and Suspension (Nonprocurement).
- b. 2 CFR Part 200 – Uniform Administrative Requirements, Cost Principles, and Audit Requirements for Federal Awards. ^{4,5}
- c. 2 CFR Part 1200 – Nonprocurement Suspension and Debarment.
- d. 14 CFR Part 13 – Investigative and Enforcement Procedures.
- e. 14 CFR Part 16 – Rules of Practice for Federally-Assisted Airport Enforcement Proceedings.
- f. 14 CFR Part 150 – Airport Noise Compatibility Planning.
- g. 28 CFR Part 35 – Nondiscrimination on the Basis of Disability in State and Local Government Services.
- h. 28 CFR § 50.3 – U.S. Department of Justice Guidelines for the Enforcement of Title VI of the Civil Rights Act of 1964.

- i. 29 CFR Part 1 – Procedures for Predetermination of Wage Rates.¹
- j. 29 CFR Part 3 – Contractors and Subcontractors on Public Building or Public Work Financed in Whole or in Part by Loans or Grants from the United States.¹
- k. 29 CFR Part 5 – Labor Standards Provisions Applicable to Contracts Covering Federally Financed and Assisted Construction (Also Labor Standards Provisions Applicable to Nonconstruction Contracts Subject to the Contract Work Hours and Safety Standards Act).¹
- l. 41 CFR Part 60 – Office of Federal Contract Compliance Programs, Equal Employment Opportunity, Department of Labor (Federal and Federally-assisted contracting requirements).¹
- m. 49 CFR Part 20 – New Restrictions on Lobbying.
- n. 49 CFR Part 21 – Nondiscrimination in Federally-Assisted Programs of the Department of Transportation - Effectuation of Title VI of the Civil Rights Act of 1964.
- o. 49 CFR Part 23 – Participation by Disadvantage Business Enterprise in Airport Concessions.
- p. 49 CFR Part 24 – Uniform Relocation Assistance and Real Property Acquisition for Federal and Federally-Assisted Programs.^{1, 2}
- q. 49 CFR Part 26 – Participation by Disadvantaged Business Enterprises in Department of Transportation Financial Assistance Programs.
- r. 49 CFR Part 27 – Nondiscrimination on the Basis of Disability in Programs or Activities Receiving Federal Financial Assistance.¹
- s. 49 CFR Part 28 – Enforcement of Nondiscrimination on the Basis of Handicap in Programs or Activities Conducted by the Department of Transportation.
- t. 49 CFR Part 30 – Denial of Public Works Contracts to Suppliers of Goods and Services of Countries That Deny Procurement Market Access to U.S. Contractors.
- u. 49 CFR Part 32 – Governmentwide Requirements for Drug-Free Workplace (Financial Assistance).
- v. 49 CFR Part 37 – Transportation Services for Individuals with Disabilities (ADA).
- w. 49 CFR Part 38 – Americans with Disabilities Act (ADA) Accessibility Specifications for Transportation Vehicles.
- x. 49 CFR Part 41 – Seismic Safety.

FOOTNOTES TO ASSURANCE (C)(1)

- ¹ These laws do not apply to airport planning sponsors.
- ² These laws do not apply to private sponsors.
- ³ 2 CFR Part 200 contains requirements for State and Local Governments receiving Federal assistance. Any requirement levied upon State and Local Governments by this regulation shall apply where applicable to private sponsors receiving Federal assistance under Title 49, United States Code.
- ⁴ Cost principles established in 2 CFR part 200 subpart E must be used as guidelines for determining the eligibility of specific types of expenses.
- ⁵ Audit requirements established in 2 CFR part 200 subpart F are the guidelines for audits.

SPECIFIC ASSURANCES

Specific assurances required to be included in grant agreements by any of the above laws, regulations or circulars are incorporated by reference in this Grant Agreement.

2. Responsibility and Authority of the Sponsor.

a. Public Agency Sponsor:

It has legal authority to apply for this Grant, and to finance and carry out the proposed project; that a resolution, motion or similar action has been duly adopted or passed as an official act of the applicant's governing body authorizing the filing of the application, including all understandings and assurances contained therein, and directing and authorizing the person identified as the official representative of the applicant to act in connection with the application and to provide such additional information as may be required.

b. Private Sponsor:

It has legal authority to apply for this Grant and to finance and carry out the proposed project and comply with all terms, conditions, and assurances of this Grant Agreement. It shall designate an official representative and shall in writing direct and authorize that person to file this application, including all understandings and assurances contained therein; to act in connection with this application; and to provide such additional information as may be required.

3. Sponsor Fund Availability.

It has sufficient funds available for that portion of the project costs which are not to be paid by the United States. It has sufficient funds available to assure operation and maintenance of items funded under this Grant Agreement which it will own or control.

4. Good Title.

- a. It, a public agency or the Federal government, holds good title, satisfactory to the Secretary, to the landing area of the airport or site thereof, or will give assurance satisfactory to the Secretary that good title will be acquired.
- b. For noise compatibility program projects to be carried out on the property of the sponsor, it holds good title satisfactory to the Secretary to that portion of the property upon which Federal funds will be expended or will give assurance to the Secretary that good title will be obtained.

5. Preserving Rights and Powers.

- a. It will not take or permit any action which would operate to deprive it of any of the rights and powers necessary to perform any or all of the terms, conditions, and assurances in this Grant Agreement without the written approval of the Secretary, and will act promptly to acquire, extinguish or modify any outstanding rights or claims of right of others which would interfere with such performance by the sponsor. This shall be done in a manner acceptable to the Secretary.
- b. Subject to the FAA Act of 2018, Public Law 115-254, Section 163, it will not sell, lease, encumber, or otherwise transfer or dispose of any part of its title or other interests in the property shown on Exhibit A to this application or, for a noise compatibility program project, that portion of the property upon which Federal funds have been expended, for the duration of the terms, conditions, and assurances in this Grant Agreement without approval by the

Secretary. If the transferee is found by the Secretary to be eligible under Title 49, United States Code, to assume the obligations of this Grant Agreement and to have the power, authority, and financial resources to carry out all such obligations, the sponsor shall insert in the contract or document transferring or disposing of the sponsor's interest, and make binding upon the transferee all of the terms, conditions, and assurances contained in this Grant Agreement.

- c. For all noise compatibility program projects which are to be carried out by another unit of local government or are on property owned by a unit of local government other than the sponsor, it will enter into an agreement with that government. Except as otherwise specified by the Secretary, that agreement shall obligate that government to the same terms, conditions, and assurances that would be applicable to it if it applied directly to the FAA for a grant to undertake the noise compatibility program project. That agreement and changes thereto must be satisfactory to the Secretary. It will take steps to enforce this agreement against the local government if there is substantial non-compliance with the terms of the agreement.
- d. For noise compatibility program projects to be carried out on privately owned property, it will enter into an agreement with the owner of that property which includes provisions specified by the Secretary. It will take steps to enforce this agreement against the property owner whenever there is substantial non-compliance with the terms of the agreement.
- e. If the sponsor is a private sponsor, it will take steps satisfactory to the Secretary to ensure that the airport will continue to function as a public-use airport in accordance with these assurances for the duration of these assurances.
- f. If an arrangement is made for management and operation of the airport by any agency or person other than the sponsor or an employee of the sponsor, the sponsor will reserve sufficient rights and authority to ensure that the airport will be operated and maintained in accordance with Title 49, United States Code, the regulations and the terms, conditions and assurances in this Grant Agreement and shall ensure that such arrangement also requires compliance therewith.
- g. Sponsors of commercial service airports will not permit or enter into any arrangement that results in permission for the owner or tenant of a property used as a residence, or zoned for residential use, to taxi an aircraft between that property and any location on airport. Sponsors of general aviation airports entering into any arrangement that results in permission for the owner of residential real property adjacent to or near the airport must comply with the requirements of Sec. 136 of Public Law 112-95 and the sponsor assurances.

6. Consistency with Local Plans.

The project is reasonably consistent with plans (existing at the time of submission of this application) of public agencies that are authorized by the State in which the project is located to plan for the development of the area surrounding the airport.

7. Consideration of Local Interest.

It has given fair consideration to the interest of communities in or near where the project may be located.

8. Consultation with Users.

In making a decision to undertake any airport development project under Title 49, United States Code, it has undertaken reasonable consultations with affected parties using the airport at which project is proposed.

9. Public Hearings.

In projects involving the location of an airport, an airport runway, or a major runway extension, it has afforded the opportunity for public hearings for the purpose of considering the economic, social, and environmental effects of the airport or runway location and its consistency with goals and objectives of such planning as has been carried out by the community and it shall, when requested by the Secretary, submit a copy of the transcript of such hearings to the Secretary. Further, for such projects, it has on its management board either voting representation from the communities where the project is located or has advised the communities that they have the right to petition the Secretary concerning a proposed project.

10. Metropolitan Planning Organization.

In projects involving the location of an airport, an airport runway, or a major runway extension at a medium or large hub airport, the sponsor has made available to and has provided upon request to the metropolitan planning organization in the area in which the airport is located, if any, a copy of the proposed amendment to the airport layout plan to depict the project and a copy of any airport master plan in which the project is described or depicted.

11. Pavement Preventive Maintenance-Management.

With respect to a project approved after January 1, 1995, for the replacement or reconstruction of pavement at the airport, it assures or certifies that it has implemented an effective airport pavement maintenance-management program and it assures that it will use such program for the useful life of any pavement constructed, reconstructed or repaired with Federal financial assistance at the airport. It will provide such reports on pavement condition and pavement management programs as the Secretary determines may be useful.

12. Terminal Development Prerequisites.

For projects which include terminal development at a public use airport, as defined in Title 49, it has, on the date of submittal of the project grant application, all the safety equipment required for certification of such airport under 49 U.S.C. § 44706, and all the security equipment required by rule or regulation, and has provided for access to the passenger enplaning and deplaning area of such airport to passengers enplaning and deplaning from aircraft other than air carrier aircraft.

13. Accounting System, Audit, and Record Keeping Requirements.

- a. It shall keep all project accounts and records which fully disclose the amount and disposition by the recipient of the proceeds of this Grant, the total cost of the project in connection with which this Grant is given or used, and the amount or nature of that portion of the cost of the project supplied by other sources, and such other financial records pertinent to the project. The accounts and records shall be kept in accordance with an accounting system that will facilitate an effective audit in accordance with the Single Audit Act of 1984.
- b. It shall make available to the Secretary and the Comptroller General of the United States, or any of their duly authorized representatives, for the purpose of audit and examination, any books, documents, papers, and records of the recipient that are pertinent to this Grant. The Secretary may require that an appropriate audit be conducted by a recipient. In any case in which an independent audit is made of the accounts of a sponsor relating to the disposition of the proceeds of a grant or relating to the project in connection with which this Grant was given or used, it shall file a certified copy of such audit with the Comptroller General of the United

States not later than six (6) months following the close of the fiscal year for which the audit was made.

14. Minimum Wage Rates.

It shall include, in all contracts in excess of \$2,000 for work on any projects funded under this Grant Agreement which involve labor, provisions establishing minimum rates of wages, to be predetermined by the Secretary of Labor under 40 U.S.C. §§ 3141-3144, 3146, and 3147, Public Building, Property, and Works), which contractors shall pay to skilled and unskilled labor, and such minimum rates shall be stated in the invitation for bids and shall be included in proposals or bids for the work.

15. Veteran's Preference.

It shall include in all contracts for work on any project funded under this Grant Agreement which involve labor, such provisions as are necessary to insure that, in the employment of labor (except in executive, administrative, and supervisory positions), preference shall be given to Vietnam era veterans, Persian Gulf veterans, Afghanistan-Iraq war veterans, disabled veterans, and small business concerns owned and controlled by disabled veterans as defined in 49 U.S.C. § 47112. However, this preference shall apply only where the individuals are available and qualified to perform the work to which the employment relates.

16. Conformity to Plans and Specifications.

It will execute the project subject to plans, specifications, and schedules approved by the Secretary. Such plans, specifications, and schedules shall be submitted to the Secretary prior to commencement of site preparation, construction, or other performance under this Grant Agreement, and, upon approval of the Secretary, shall be incorporated into this Grant Agreement. Any modification to the approved plans, specifications, and schedules shall also be subject to approval of the Secretary, and incorporated into this Grant Agreement.

17. Construction Inspection and Approval.

It will provide and maintain competent technical supervision at the construction site throughout the project to assure that the work conforms to the plans, specifications, and schedules approved by the Secretary for the project. It shall subject the construction work on any project contained in an approved project application to inspection and approval by the Secretary and such work shall be in accordance with regulations and procedures prescribed by the Secretary. Such regulations and procedures shall require such cost and progress reporting by the sponsor or sponsors of such project as the Secretary shall deem necessary.

18. Planning Projects.

In carrying out planning projects:

- a. It will execute the project in accordance with the approved program narrative contained in the project application or with the modifications similarly approved.
- b. It will furnish the Secretary with such periodic reports as required pertaining to the planning project and planning work activities.
- c. It will include in all published material prepared in connection with the planning project a notice that the material was prepared under a grant provided by the United States.

- d. It will make such material available for examination by the public, and agrees that no material prepared with funds under this project shall be subject to copyright in the United States or any other country.
- e. It will give the Secretary unrestricted authority to publish, disclose, distribute, and otherwise use any of the material prepared in connection with this grant.
- f. It will grant the Secretary the right to disapprove the sponsor's employment of specific consultants and their subcontractors to do all or any part of this project as well as the right to disapprove the proposed scope and cost of professional services.
- g. It will grant the Secretary the right to disapprove the use of the sponsor's employees to do all or any part of the project.
- h. It understands and agrees that the Secretary's approval of this project grant or the Secretary's approval of any planning material developed as part of this grant does not constitute or imply any assurance or commitment on the part of the Secretary to approve any pending or future application for a Federal airport grant.

19. Operation and Maintenance.

- a. The airport and all facilities which are necessary to serve the aeronautical users of the airport, other than facilities owned or controlled by the United States, shall be operated at all times in a safe and serviceable condition and in accordance with the minimum standards as may be required or prescribed by applicable Federal, state, and local agencies for maintenance and operation. It will not cause or permit any activity or action thereon which would interfere with its use for airport purposes. It will suitably operate and maintain the airport and all facilities thereon or connected therewith, with due regard to climatic and flood conditions. Any proposal to temporarily close the airport for non-aeronautical purposes must first be approved by the Secretary. In furtherance of this assurance, the sponsor will have in effect arrangements for:
 - 1. Operating the airport's aeronautical facilities whenever required;
 - 2. Promptly marking and lighting hazards resulting from airport conditions, including temporary conditions; and
 - 3. Promptly notifying pilots of any condition affecting aeronautical use of the airport. Nothing contained herein shall be construed to require that the airport be operated for aeronautical use during temporary periods when snow, flood, or other climatic conditions interfere with such operation and maintenance. Further, nothing herein shall be construed as requiring the maintenance, repair, restoration, or replacement of any structure or facility which is substantially damaged or destroyed due to an act of God or other condition or circumstance beyond the control of the sponsor.
- b. It will suitably operate and maintain noise compatibility program items that it owns or controls upon which Federal funds have been expended.

20. Hazard Removal and Mitigation.

It will take appropriate action to assure that such terminal airspace as is required to protect instrument and visual operations to the airport (including established minimum flight altitudes) will be adequately cleared and protected by removing, lowering, relocating, marking, or lighting or otherwise mitigating existing airport hazards and by preventing the establishment or creation of future airport hazards.

21. Compatible Land Use.

It will take appropriate action, to the extent reasonable, including the adoption of zoning laws, to restrict the use of land adjacent to or in the immediate vicinity of the airport to activities and purposes compatible with normal airport operations, including landing and takeoff of aircraft. In addition, if the project is for noise compatibility program implementation, it will not cause or permit any change in land use, within its jurisdiction, that will reduce its compatibility, with respect to the airport, of the noise compatibility program measures upon which Federal funds have been expended.

22. Economic Nondiscrimination.

- a. It will make the airport available as an airport for public use on reasonable terms and without unjust discrimination to all types, kinds and classes of aeronautical activities, including commercial aeronautical activities offering services to the public at the airport.
- b. In any agreement, contract, lease, or other arrangement under which a right or privilege at the airport is granted to any person, firm, or corporation to conduct or to engage in any aeronautical activity for furnishing services to the public at the airport, the sponsor will insert and enforce provisions requiring the contractor to:
 1. Furnish said services on a reasonable, and not unjustly discriminatory, basis to all users thereof, and
 2. Charge reasonable, and not unjustly discriminatory, prices for each unit or service, provided that the contractor may be allowed to make reasonable and nondiscriminatory discounts, rebates, or other similar types of price reductions to volume purchasers.
- c. Each fixed-based operator at the airport shall be subject to the same rates, fees, rentals, and other charges as are uniformly applicable to all other fixed-based operators making the same or similar uses of such airport and utilizing the same or similar facilities.
- d. Each air carrier using such airport shall have the right to service itself or to use any fixed-based operator that is authorized or permitted by the airport to serve any air carrier at such airport.
- e. Each air carrier using such airport (whether as a tenant, non-tenant, or subtenant of another air carrier tenant) shall be subject to such nondiscriminatory and substantially comparable rules, regulations, conditions, rates, fees, rentals, and other charges with respect to facilities directly and substantially related to providing air transportation as are applicable to all such air carriers which make similar use of such airport and utilize similar facilities, subject to reasonable classifications such as tenants or non-tenants and signatory carriers and non-signatory carriers. Classification or status as tenant or signatory shall not be unreasonably withheld by any airport provided an air carrier assumes obligations substantially similar to those already imposed on air carriers in such classification or status.
- f. It will not exercise or grant any right or privilege which operates to prevent any person, firm, or corporation operating aircraft on the airport from performing any services on its own aircraft with its own employees (including, but not limited to maintenance, repair, and fueling) that it may choose to perform.
- g. In the event the sponsor itself exercises any of the rights and privileges referred to in this assurance, the services involved will be provided on the same conditions as would apply to the furnishing of such services by commercial aeronautical service providers authorized by the sponsor under these provisions.

- h. The sponsor may establish such reasonable, and not unjustly discriminatory, conditions to be met by all users of the airport as may be necessary for the safe and efficient operation of the airport.
- i. The sponsor may prohibit or limit any given type, kind or class of aeronautical use of the airport if such action is necessary for the safe operation of the airport or necessary to serve the civil aviation needs of the public.

23. Exclusive Rights.

It will permit no exclusive right for the use of the airport by any person providing, or intending to provide, aeronautical services to the public. For purposes of this paragraph, the providing of the services at an airport by a single fixed-based operator shall not be construed as an exclusive right if both of the following apply:

- a. It would be unreasonably costly, burdensome, or impractical for more than one fixed-based operator to provide such services, and
- b. If allowing more than one fixed-based operator to provide such services would require the reduction of space leased pursuant to an existing agreement between such single fixed-based operator and such airport. It further agrees that it will not, either directly or indirectly, grant or permit any person, firm, or corporation, the exclusive right at the airport to conduct any aeronautical activities, including, but not limited to charter flights, pilot training, aircraft rental and sightseeing, aerial photography, crop dusting, aerial advertising and surveying, air carrier operations, aircraft sales and services, sale of aviation petroleum products whether or not conducted in conjunction with other aeronautical activity, repair and maintenance of aircraft, sale of aircraft parts, and any other activities which because of their direct relationship to the operation of aircraft can be regarded as an aeronautical activity, and that it will terminate any exclusive right to conduct an aeronautical activity now existing at such an airport before the grant of any assistance under Title 49, United States Code.

24. Fee and Rental Structure.

It will maintain a fee and rental structure for the facilities and services at the airport which will make the airport as self-sustaining as possible under the circumstances existing at the particular airport, taking into account such factors as the volume of traffic and economy of collection. No part of the Federal share of an airport development, airport planning or noise compatibility project for which a Grant is made under Title 49, United States Code, the Airport and Airway Improvement Act of 1982, the Federal Airport Act or the Airport and Airway Development Act of 1970 shall be included in the rate basis in establishing fees, rates, and charges for users of that airport.

25. Airport Revenues.

- a. All revenues generated by the airport and any local taxes on aviation fuel established after December 30, 1987, will be expended by it for the capital or operating costs of the airport; the local airport system; or other local facilities which are owned or operated by the owner or operator of the airport and which are directly and substantially related to the actual air transportation of passengers or property; or for noise mitigation purposes on or off the airport. The following exceptions apply to this paragraph:
 - 1. If covenants or assurances in debt obligations issued before September 3, 1982, by the owner or operator of the airport, or provisions enacted before September 3, 1982, in governing statutes controlling the owner or operator's financing, provide for the use of the

revenues from any of the airport owner or operator's facilities, including the airport, to support not only the airport but also the airport owner or operator's general debt obligations or other facilities, then this limitation on the use of all revenues generated by the airport (and, in the case of a public airport, local taxes on aviation fuel) shall not apply.

2. If the Secretary approves the sale of a privately owned airport to a public sponsor and provides funding for any portion of the public sponsor's acquisition of land, this limitation on the use of all revenues generated by the sale shall not apply to certain proceeds from the sale. This is conditioned on repayment to the Secretary by the private owner of an amount equal to the remaining unamortized portion (amortized over a 20-year period) of any airport improvement grant made to the private owner for any purpose other than land acquisition on or after October 1, 1996, plus an amount equal to the federal share of the current fair market value of any land acquired with an airport improvement grant made to that airport on or after October 1, 1996.
 3. Certain revenue derived from or generated by mineral extraction, production, lease, or other means at a general aviation airport (as defined at 49 U.S.C. § 47102), if the FAA determines the airport sponsor meets the requirements set forth in Section 813 of Public Law 112-95.
- b. As part of the annual audit required under the Single Audit Act of 1984, the sponsor will direct that the audit will review, and the resulting audit report will provide an opinion concerning, the use of airport revenue and taxes in paragraph (a), and indicating whether funds paid or transferred to the owner or operator are paid or transferred in a manner consistent with Title 49, United States Code and any other applicable provision of law, including any regulation promulgated by the Secretary or Administrator.
 - c. Any civil penalties or other sanctions will be imposed for violation of this assurance in accordance with the provisions of 49 U.S.C. § 47107.

26. Reports and Inspections.

It will:

- a. submit to the Secretary such annual or special financial and operations reports as the Secretary may reasonably request and make such reports available to the public; make available to the public at reasonable times and places a report of the airport budget in a format prescribed by the Secretary;
- b. for airport development projects, make the airport and all airport records and documents affecting the airport, including deeds, leases, operation and use agreements, regulations and other instruments, available for inspection by any duly authorized agent of the Secretary upon reasonable request;
- c. for noise compatibility program projects, make records and documents relating to the project and continued compliance with the terms, conditions, and assurances of this Grant Agreement including deeds, leases, agreements, regulations, and other instruments, available for inspection by any duly authorized agent of the Secretary upon reasonable request; and
- d. in a format and time prescribed by the Secretary, provide to the Secretary and make available to the public following each of its fiscal years, an annual report listing in detail:
 1. all amounts paid by the airport to any other unit of government and the purposes for which each such payment was made; and

2. all services and property provided by the airport to other units of government and the amount of compensation received for provision of each such service and property.

27. Use by Government Aircraft.

It will make available all of the facilities of the airport developed with Federal financial assistance and all those usable for landing and takeoff of aircraft to the United States for use by Government aircraft in common with other aircraft at all times without charge, except, if the use by Government aircraft is substantial, charge may be made for a reasonable share, proportional to such use, for the cost of operating and maintaining the facilities used. Unless otherwise determined by the Secretary, or otherwise agreed to by the sponsor and the using agency, substantial use of an airport by Government aircraft will be considered to exist when operations of such aircraft are in excess of those which, in the opinion of the Secretary, would unduly interfere with use of the landing areas by other authorized aircraft, or during any calendar month that:

- a. Five (5) or more Government aircraft are regularly based at the airport or on land adjacent thereto; or
- b. The total number of movements (counting each landing as a movement) of Government aircraft is 300 or more, or the gross accumulative weight of Government aircraft using the airport (the total movement of Government aircraft multiplied by gross weights of such aircraft) is in excess of five million pounds.

28. Land for Federal Facilities.

It will furnish without cost to the Federal Government for use in connection with any air traffic control or air navigation activities, or weather-reporting and communication activities related to air traffic control, any areas of land or water, or estate therein as the Secretary considers necessary or desirable for construction, operation, and maintenance at Federal expense of space or facilities for such purposes. Such areas or any portion thereof will be made available as provided herein within four months after receipt of a written request from the Secretary.

29. Airport Layout Plan.

- a. Subject to the FAA Reauthorization Act of 2018, Public Law 115-254, Section 163, it will keep up to date at all times an airport layout plan of the airport showing:
 1. boundaries of the airport and all proposed additions thereto, together with the boundaries of all offsite areas owned or controlled by the sponsor for airport purposes and proposed additions thereto;
 2. the location and nature of all existing and proposed airport facilities and structures (such as runways, taxiways, aprons, terminal buildings, hangars and roads), including all proposed extensions and reductions of existing airport facilities;
 3. the location of all existing and proposed non-aviation areas and of all existing improvements thereon; and
 4. all proposed and existing access points used to taxi aircraft across the airport's property boundary.

Such airport layout plans and each amendment, revision, or modification thereof, shall be subject to the approval of the Secretary which approval shall be evidenced by the signature of a duly authorized representative of the Secretary on the face of the airport layout plan. The sponsor will not make or permit any changes or alterations in the airport or any of its facilities

which are not in conformity with the airport layout plan as approved by the Secretary and which might, in the opinion of the Secretary, adversely affect the safety, utility or efficiency of the airport.

- b. Subject to the FAA Reauthorization Act of 2018, Public Law 115-254, Section 163, if a change or alteration in the airport or the facilities is made which the Secretary determines adversely affects the safety, utility, or efficiency of any federally owned, leased, or funded property on or off the airport and which is not in conformity with the airport layout plan as approved by the Secretary, the owner or operator will, if requested, by the Secretary:
 1. eliminate such adverse effect in a manner approved by the Secretary; or
 2. bear all costs of relocating such property (or replacement thereof) to a site acceptable to the Secretary and all costs of restoring such property (or replacement thereof) to the level of safety, utility, efficiency, and cost of operation existing before the unapproved change in the airport or its facilities except in the case of a relocation or replacement of an existing airport facility due to a change in the Secretary's design standards beyond the control of the airport sponsor.

30. Civil Rights.

It will promptly take any measures necessary to ensure that no person in the United States shall, on the grounds of race, color, and national origin (including limited English proficiency) in accordance with the provisions of Title VI of the Civil Rights Act of 1964 (78 Stat. 252, 42 U.S.C. §§ 2000d to 2000d-4); creed and sex (including sexual orientation and gender identity) per 49 U.S.C. § 47123 and related requirements; age per the Age Discrimination Act of 1975 and related requirements; or disability per the Americans with Disabilities Act of 1990 and related requirements, be excluded from participation in, be denied the benefits of, or be otherwise subjected to discrimination in any program and activity conducted with, or benefiting from, funds received from this Grant.

- a. Using the definitions of activity, facility, and program as found and defined in 49 CFR §§ 21.23(b) and 21.23(e), the sponsor will facilitate all programs, operate all facilities, or conduct all programs in compliance with all non-discrimination requirements imposed by or pursuant to these assurances.
- b. Applicability
 1. Programs and Activities. If the sponsor has received a grant (or other federal assistance) for any of the sponsor's program or activities, these requirements extend to all of the sponsor's programs and activities.
 2. Facilities. Where it receives a grant or other federal financial assistance to construct, expand, renovate, remodel, alter, or acquire a facility, or part of a facility, the assurance extends to the entire facility and facilities operated in connection therewith.
 3. Real Property. Where the sponsor receives a grant or other Federal financial assistance in the form of, or for the acquisition of real property or an interest in real property, the assurance will extend to rights to space on, over, or under such property.
- c. Duration.

The sponsor agrees that it is obligated to this assurance for the period during which Federal financial assistance is extended to the program, except where the Federal financial assistance is to provide, or is in the form of, personal property, or real property, or interest therein, or

structures or improvements thereon, in which case the assurance obligates the sponsor, or any transferee for the longer of the following periods:

1. So long as the airport is used as an airport, or for another purpose involving the provision of similar services or benefits; or
 2. So long as the sponsor retains ownership or possession of the property.
- d. Required Solicitation Language. It will include the following notification in all solicitations for bids, Requests For Proposals for work, or material under this Grant Agreement and in all proposals for agreements, including airport concessions, regardless of funding source:
- “The sponsor, in accordance with the provisions of Title VI of the Civil Rights Act of 1964 (78 Stat. 252, 42 U.S.C. §§ 2000d to 2000d-4) and the Regulations, hereby notifies all bidders or offerors that it will affirmatively ensure that for any contract entered into pursuant to this advertisement, [select businesses, or disadvantaged business enterprises or airport concession disadvantaged business enterprises] will be afforded full and fair opportunity to submit bids in response to this invitation and no businesses will be discriminated against on the grounds of race, color, national origin (including limited English proficiency), creed, sex (including sexual orientation and gender identity), age, or disability in consideration for an award.”
- e. Required Contract Provisions.
1. It will insert the non-discrimination contract clauses requiring compliance with the acts and regulations relative to non-discrimination in Federally-assisted programs of the Department of Transportation (DOT), and incorporating the acts and regulations into the contracts by reference in every contract or agreement subject to the non-discrimination in Federally-assisted programs of the DOT acts and regulations.
 2. It will include a list of the pertinent non-discrimination authorities in every contract that is subject to the non-discrimination acts and regulations.
 3. It will insert non-discrimination contract clauses as a covenant running with the land, in any deed from the United States effecting or recording a transfer of real property, structures, use, or improvements thereon or interest therein to a sponsor.
 4. It will insert non-discrimination contract clauses prohibiting discrimination on the basis of race, color, national origin (including limited English proficiency), creed, sex (including sexual orientation and gender identity), age, or disability as a covenant running with the land, in any future deeds, leases, license, permits, or similar instruments entered into by the sponsor with other parties:
 - a. For the subsequent transfer of real property acquired or improved under the applicable activity, project, or program; and
 - b. For the construction or use of, or access to, space on, over, or under real property acquired or improved under the applicable activity, project, or program.
- f. It will provide for such methods of administration for the program as are found by the Secretary to give reasonable guarantee that it, other recipients, sub-recipients, sub-grantees, contractors, subcontractors, consultants, transferees, successors in interest, and other participants of Federal financial assistance under such program will comply with all requirements imposed or pursuant to the acts, the regulations, and this assurance.

- g. It agrees that the United States has a right to seek judicial enforcement with regard to any matter arising under the acts, the regulations, and this assurance.

31. Disposal of Land.

- a. For land purchased under a grant for airport noise compatibility purposes, including land serving as a noise buffer, it will dispose of the land, when the land is no longer needed for such purposes, at fair market value, at the earliest practicable time. That portion of the proceeds of such disposition which is proportionate to the United States' share of acquisition of such land will be, at the discretion of the Secretary, (1) reinvested in another project at the airport, or (2) transferred to another eligible airport as prescribed by the Secretary. The Secretary shall give preference to the following, in descending order:

1. Reinvestment in an approved noise compatibility project;
2. Reinvestment in an approved project that is eligible for grant funding under 49 U.S.C. § 47117(e);
3. Reinvestment in an approved airport development project that is eligible for grant funding under 49 U.S.C. §§ 47114, 47115, or 47117;
4. Transfer to an eligible sponsor of another public airport to be reinvested in an approved noise compatibility project at that airport; or
5. Payment to the Secretary for deposit in the Airport and Airway Trust Fund.

If land acquired under a grant for noise compatibility purposes is leased at fair market value and consistent with noise buffering purposes, the lease will not be considered a disposal of the land. Revenues derived from such a lease may be used for an approved airport development project that would otherwise be eligible for grant funding or any permitted use of airport revenue.

- b. For land purchased under a grant for airport development purposes (other than noise compatibility), it will, when the land is no longer needed for airport purposes, dispose of such land at fair market value or make available to the Secretary an amount equal to the United States' proportionate share of the fair market value of the land. That portion of the proceeds of such disposition which is proportionate to the United States' share of the cost of acquisition of such land will, upon application to the Secretary, be reinvested or transferred to another eligible airport as prescribed by the Secretary. The Secretary shall give preference to the following, in descending order:

1. Reinvestment in an approved noise compatibility project;
2. Reinvestment in an approved project that is eligible for grant funding under 49 U.S.C. § 47117(e);
3. Reinvestment in an approved airport development project that is eligible for grant funding under 49 U.S.C. §§ 47114, 47115, or 47117;
4. Transfer to an eligible sponsor of another public airport to be reinvested in an approved noise compatibility project at that airport; or
5. Payment to the Secretary for deposit in the Airport and Airway Trust Fund.

- c. Land shall be considered to be needed for airport purposes under this assurance if (1) it may be needed for aeronautical purposes (including runway protection zones) or serve as noise buffer

land, and (2) the revenue from interim uses of such land contributes to the financial self-sufficiency of the airport. Further, land purchased with a grant received by an airport operator or owner before December 31, 1987, will be considered to be needed for airport purposes if the Secretary or Federal agency making such grant before December 31, 1987, was notified by the operator or owner of the uses of such land, did not object to such use, and the land continues to be used for that purpose, such use having commenced no later than December 15, 1989.

- d. Disposition of such land under (a), (b), or (c) will be subject to the retention or reservation of any interest or right therein necessary to ensure that such land will only be used for purposes which are compatible with noise levels associated with operation of the airport.

32. Engineering and Design Services.

If any phase of such project has received Federal funds under Chapter 471 subchapter 1 of Title 49 U.S.C., it will award each contract, or sub-contract for program management, construction management, planning studies, feasibility studies, architectural services, preliminary engineering, design, engineering, surveying, mapping or related services in the same manner as a contract for architectural and engineering services is negotiated under Chapter 11 of Title 40 U.S.C., or an equivalent qualifications-based requirement prescribed for or by the sponsor of the airport.

33. Foreign Market Restrictions.

It will not allow funds provided under this Grant to be used to fund any project which uses any product or service of a foreign country during the period in which such foreign country is listed by the United States Trade Representative as denying fair and equitable market opportunities for products and suppliers of the United States in procurement and construction.

34. Policies, Standards, and Specifications.

It will carry out any project funded under an Airport Improvement Program Grant in accordance with policies, standards, and specifications approved by the Secretary including, but not limited to, current FAA Advisory Circulars (<https://www.faa.gov/airports/aip/media/aip-pfc-checklist.pdf>) for AIP projects as of February 21, 2023.

35. Relocation and Real Property Acquisition.

- a. It will be guided in acquiring real property, to the greatest extent practicable under State law, by the land acquisition policies in Subpart B of 49 CFR Part 24 and will pay or reimburse property owners for necessary expenses as specified in Subpart B.
- b. It will provide a relocation assistance program offering the services described in Subpart C of 49 CFR Part 24 and fair and reasonable relocation payments and assistance to displaced persons as required in Subpart D and E of 49 CFR Part 24.
- c. It will make available within a reasonable period of time prior to displacement, comparable replacement dwellings to displaced persons in accordance with Subpart E of 49 CFR Part 24.

36. Access By Intercity Buses.

The airport owner or operator will permit, to the maximum extent practicable, intercity buses or other modes of transportation to have access to the airport; however, it has no obligation to fund special facilities for intercity buses or for other modes of transportation.

37. Disadvantaged Business Enterprises.

The sponsor shall not discriminate on the basis of race, color, national origin, or sex, in the award and performance of any DOT-assisted contract covered by 49 CFR Part 26, or in the award and performance of any concession activity contract covered by 49 CFR Part 23. In addition, the sponsor shall not discriminate on the basis of race, color, national origin or sex in the administration of its Disadvantaged Business Enterprise (DBE) and Airport Concessions Disadvantaged Business Enterprise (ACDBE) programs or the requirements of 49 CFR Parts 23 and 26. The sponsor shall take all necessary and reasonable steps under 49 CFR Parts 23 and 26 to ensure nondiscrimination in the award and administration of DOT-assisted contracts, and/or concession contracts. The sponsor's DBE and ACDBE programs, as required by 49 CFR Parts 26 and 23, and as approved by DOT, are incorporated by reference in this agreement. Implementation of these programs is a legal obligation and failure to carry out its terms shall be treated as a violation of this agreement. Upon notification to the sponsor of its failure to carry out its approved program, the Department may impose sanctions as provided for under Parts 26 and 23 and may, in appropriate cases, refer the matter for enforcement under 18 U.S.C. § 1001 and/or the Program Fraud Civil Remedies Act of 1986 (31 U.S.C. §§ 3801-3809, 3812).

38. Hangar Construction.

If the airport owner or operator and a person who owns an aircraft agree that a hangar is to be constructed at the airport for the aircraft at the aircraft owner's expense, the airport owner or operator will grant to the aircraft owner for the hangar a long term lease that is subject to such terms and conditions on the hangar as the airport owner or operator may impose.

39. Competitive Access.

- a. If the airport owner or operator of a medium or large hub airport (as defined in 49 U.S.C. § 47102) has been unable to accommodate one or more requests by an air carrier for access to gates or other facilities at that airport in order to allow the air carrier to provide service to the airport or to expand service at the airport, the airport owner or operator shall transmit a report to the Secretary that:
 1. Describes the requests;
 2. Provides an explanation as to why the requests could not be accommodated; and
 3. Provides a time frame within which, if any, the airport will be able to accommodate the requests.
- b. Such report shall be due on either February 1 or August 1 of each year if the airport has been unable to accommodate the request(s) in the six month period prior to the applicable due date.



Current FAA Advisory Circulars Required for Use in AIP Funded and PFC Approved Projects

View the most current versions of FAA's Advisory Circulars (A/Cs) here:

https://www.faa.gov/regulations_policies/advisory_circulars/

Airports A/Cs are found in the 150 series. In addition Airspace A/Cs, found in the 70 series, also may apply for certain projects.

Application for Federal Assistance SF-424

*1. Type of Submission:

- Preapplication
 Application
 Changed/Corrected Application

*2. Type of Application

- New
 Continuation
 Revision

* If Revision, select appropriate letter(s):

* Other (Specify)

*3. Date Received:

4. Applicant Identifier:

5a. Federal Entity Identifier:

3-31-0019-017-2023 (B01)

5b. Federal Award Identifier:

State Use Only:

6. Date Received by State:

7. State Application Identifier: 3-31-0019-017-2023 (B01)

8. APPLICANT INFORMATION:

*a. Legal Name: City of Columbus

*b. Employer/Taxpayer Identification Number (EIN/TIN):

47-6006144

*c. UEI:

YM4RJGN196F5

d. Address:

*Street 1: P.O. Box 1677

Street 2:

*City: Columbus

County/Parish:

*State: Province: NE

*Country:

*Zip / Postal Code USA: United States

68602-1677

e. Organizational Unit:

Department Name:

City of Columbus

Division Name:

f. Name and contact information of person to be contacted on matters involving this application:

Prefix: Mr. *First Name: Suman

Middle Name:

*Last Name: Pusparajah

Suffix:

Title: Engineer

Organizational Affiliation:

Nebraska Department of Transportation, Division of Aeronautics

*Telephone Number: 402-471-2371

Fax Number:

*Email: suman.pusparajah@nebraska.gov

Application for Federal Assistance SF-424

***9. Type of Applicant 1: Select Applicant Type:**

C: City or Township Government

Type of Applicant 2: Select Applicant Type:

Pick an applicant type

Type of Applicant 3: Select Applicant Type:

Pick an applicant type

*Other (Specify)

***10. Name of Federal Agency:**

11. Catalog of Federal Domestic Assistance Number:

20.106

CFDA Title:

Airport Improvement Program

***12. Funding Opportunity Number:**

*Title:

N/A

13. Competition Identification Number:

Title:

N/A

14. Areas Affected by Project (Cities, Counties, States, etc.):

***15. Descriptive Title of Applicant's Project:**

Construct 8-place T-Hangar

Attach supporting documents as specified in agency instructions.

Application for Federal Assistance SF-424

16. Congressional Districts Of:

* a. Applicant

* b. Program/Project

Attach an additional list of Program/Project Congressional Districts if needed.

17. Proposed Project:

* a. Start Date:

* b. End Date:

18. Estimated Funding (\$):

* a. Federal	<input type="text" value="1,521,000.00"/>
* b. Applicant	<input type="text" value="169,000.00"/>
* c. State	<input type="text" value="0.00"/>
* d. Local	<input type="text" value="0.00"/>
* e. Other	<input type="text" value="0.00"/>
* f. Program Income	<input type="text" value="0.00"/>
* g. TOTAL	<input type="text" value="1,690,000.00"/>

*** 19. Is Application Subject to Review By State Under Executive Order 12372 Process?**

- a. This application was made available to the State under the Executive Order 12372 Process for review on
- b. Program is subject to E.O. 12372 but has not been selected by the State for review.
- c. Program is not covered by E.O. 12372.

*** 20. Is the Applicant Delinquent On Any Federal Debt? (If "Yes," provide explanation in attachment.)**

Yes No

If "Yes", provide explanation and attach

21. *By signing this application, I certify (1) to the statements contained in the list of certifications and (2) that the statements herein are true, complete and accurate to the best of my knowledge. I also provide the required assurances** and agree to comply with any resulting terms if I accept an award. I am aware that any false, fictitious, or fraudulent statements or claims may subject me to criminal, civil, or administrative penalties. (U.S. Code, Title 218, Section 1001)**

** I AGREE

** The list of certifications and assurances, or an internet site where you may obtain this list, is contained in the announcement or agency specific instructions.

Authorized Representative:

Prefix: * First Name:

Middle Name:

* Last Name:

Suffix:

* Title:

* Telephone Number: Fax Number:

* Email:

* Signature of Authorized Representative: 

* Date Signed:

PART II – SECTION C

The Sponsor hereby represents and certifies as follows:

1. Compatible Land Use – The Sponsor has taken the following actions to assure compatible usage of land adjacent to or in the vicinity of the airport:

The area around the airport is zoned for a distance of three miles from the airport property line, to control the height of structures in the vicinity of the airport. Height restriction zoning was adopted on September 20th, 2002.

2. Defaults – The Sponsor is not in default on any obligation to the United States or any agency of the United States Government relative to the development, operation, or maintenance of any airport, except as stated herewith:

None.

3. Possible Disabilities – There are no facts or circumstances (including the existence of effective or proposed leases, use agreements or other legal instruments affecting use of the Airport or the existence of pending litigation or other legal proceedings) which in reasonable probability might make it impossible for the Sponsor to carry out and complete the Project or carry out the provisions of the Grant Assurances, either by limiting its legal or financial ability or otherwise, except as follows:

None.

4. Consistency with Local Plans – The project is reasonably consistent with plans existing at the time of submission of this application) of public agencies that are authorized by the State in which the project is located to plan for the development of the area surrounding the airport.

Yes.

5. Consideration of Local Interest – It has given fair consideration to the interest of communities in or near where the project may be located.

Yes.

6. Consultation with Users – In making a decision to undertake an airport development project under Title 49, United States Code, it has consulted with airport users that will potentially be affected by the project (§ 47105(a)(2)).

Yes.

7. Public Hearings – In projects involving the location of an airport, an airport runway or a major runway extension, it has afforded the opportunity for public hearings for the purpose of considering the economic, social, and environmental effects of the airport or runway location and its consistency with goals and objectives of such planning as has been carried out by the community and it shall, when requested by the Secretary, submit a copy of the transcript of such hearings to the Secretary. Further, for such projects, it has on its management board either voting representation from the communities where the project is located or has advised the communities that they have the right to petition the Secretary concerning a proposed project.

N/A

8. Air and Water Quality Standards – In projects involving airport location, a major runway extension, or runway location it will provide for the Governor of the state in which the project is located to certify in writing to the Secretary that the project will be located, designed, constructed, and operated so as to comply with applicable and air and water quality standards. In any case where such standards have not been approved and where applicable air and water quality standards have been promulgated by the Administrator of the Environmental Protection Agency, certification shall be obtained from such Administrator. Notice of certification or refusal to certify shall be provided within sixty days after the project application has been received by the Secretary.

N/A

PART II – SECTION C (Continued)

9. Exclusive Rights – There is no grant of an exclusive right for the conduct of any aeronautical activity at any airport owned or controlled by the Sponsor except as follows:

None.

10. Land – (a) The sponsor holds the following property interest in the following areas of land, which are to be developed or used as part of or in connection with the Airport subject to the following exceptions, encumbrances, and adverse interests, all of which areas are identified on the aforementioned property map designated as Exhibit "A". [1]

Sponsor maintains property interest as depicted within property table on the Exhibit A Property Map dated May 5th, 2015.

The Sponsor further certifies that the above is based on a title examination by a qualified attorney or title company and that such attorney or title company has determined that the Sponsor holds the above property interests.

(b) The Sponsor will acquire within a reasonable time, but in any event prior to the start of any construction work under the Project, the following property interest in the following areas of land on which such construction work is to be performed, all of which areas are identified on the aforementioned property map designated as Exhibit "A". [1]

None.

(c) The Sponsor will acquire within a reasonable time, and if feasible prior to the completion of all construction work under the Project, the following property interest in the following areas of land which are to be developed or used as part of or in connection with the Airport as it will be upon completion of the Project, all of which areas are identified on the aforementioned property map designated as Exhibit "A". [1]

None.

¹ State the character of property interest in each area and list and identify for each all exceptions, encumbrances, and adverse interests of every kind and nature, including liens, easements, leases, etc. The separate areas of land need only be identified here by the area numbers shown on the property map.

PART III – BUDGET INFORMATION – CONSTRUCTION

SECTION A – GENERAL	
1. Assistance Listing Number:	20-106
2. Functional or Other Breakout:	

SECTION B – CALCULATION OF FEDERAL GRANT			
Cost Classification	Latest Approved Amount (Use only for revisions)	Adjustment + or (-) Amount (Use only for revisions)	Total Amount Required
1. Administration expense			\$ 10,000
2. Preliminary expense			
3. Land, structures, right-of-way			
4. Architectural engineering basic fees			120,000
5. Other Architectural engineering fees			
6. Project inspection fees			1,560,000
7. Land development			
8. Relocation Expenses			
9. Relocation payments to Individuals and Businesses			
10. Demolition and removal			
11. Construction and project improvement			
12. Equipment			
13. Miscellaneous			
14. Subtotal (Lines 1 through 13)			\$ 1,690,000
15. Estimated Income (if applicable)			
16. Net Project Amount (Line 14 minus 15)			
17. Less: Ineligible Exclusions (Section C, line 23 g.)			
18. Subtotal (Lines 16 through 17)			\$ 1,690,000
19. Federal Share requested of Line 18			1,521,000
20. Grantee share			169,000
21. Other shares			
22. TOTAL PROJECT (Lines 19, 20 & 21)			\$ 169,000

SECTION C – EXCLUSIONS	
23. Classification (Description of non-participating work)	Amount Ineligible for Participation
a.	
b.	
c.	
d.	
e.	
f.	
g. Total	

SECTION D – PROPOSED METHOD OF FINANCING NON-FEDERAL SHARE	
24. Grantee Share – Fund Categories	Amount
a. Securities	
b. Mortgages	
c. Appropriations (by Applicant)	169,000
d. Bonds	
e. Tax Levies	
f. Non-Cash	
g. Other (Explain):	
h. TOTAL - Grantee share	\$ 169,000
25. Other Shares	Amount
a. State	
b. Other	
c. TOTAL - Other Shares	
26. TOTAL NON-FEDERAL FINANCING	\$ 169,000

SECTION E – REMARKS (Attach sheets if additional space is required)
<p>The following items are incorporated by reference:</p> <p>Plans & Specs: to be incorporated Exhibit A: May 5th, 2015</p>

PART IV – PROGRAM NARRATIVE
(Suggested Format)

PROJECT: Construct 8-Place T-Hangar
AIRPORT: Columbus Municipal Airport
1. Objective: To construct an 8-place T-Hangar.
2. Benefits Anticipated: This project will improve safety at the airport and extend pavement life.
3. Approach: (See approved Scope of Work in Final Application) The airport sponsor has hired an engineering/surveying consultant who will prepare construction plans and specifications, bidding documents, and observe construction. The Nebraska Department of Transportation, Aeronautics Division, will assist the Airport Sponsor with administrative issues.
4. Geographic Location: The Columbus Municipal Airport is about one and a half miles northeast of the city of Columbus, Platte County, Nebraska.
5. If Applicable, Provide Additional Information: N/A
6. Sponsor's Representative: (include address & telephone number) Janelle Kline, City Clerk P.O. BOX 1677 Columbus, Nebraska 68602-1667 (402) 562-4227

**Columbus Municipal Airport (OLU)
Columbus, Nebraska
AIP Project No. 3-31-0019-017 (B01)
T-Hangar**

COST SUMMARY:	AIP-017 Phase I (March 2023)	Phase II (FY2024)
<hr/> <hr/>		
<u>Construction</u>		
TBD		\$0.00
<u>Engineering (KM)</u>		
Design	\$134,666.71	
Bidding	\$6,556.95	
Construction		\$0.00
Close Out		\$0.00
Subtotal	\$141,223.66	
<u>Independent Fee Estimate (Airport IFE)</u>		
IFE	\$2,650.00	\$0.00
<u>Audit</u>		
		\$0.00
<u>Admin/Audit/Pub/Etc.</u>		
NDA	\$4,826.34	\$0.00
Legal	\$100.00	\$0.00
Audit/Publication	<u>\$200.00</u>	<u>\$0.00</u>
Subtotal	\$5,126.34	\$0.00
TOTALS	<hr/> \$149,000.00	<hr/> \$0.00
<u>SUMMARY OF FUNDS:</u>		
	(March 2023)	(FY2024)
<hr/> <hr/>		
Local	\$14,900.00	\$0.00
State	\$0.00	\$0.00
Federal (AIP)	\$134,100.00	\$0.00
Total	<hr/> \$149,000.00	<hr/> \$0.00

Certification and Disclosure Regarding Potential Conflicts of Interest Airport Improvement Program Sponsor Certification

Sponsor: City of Columbus

Airport: Columbus Municipal Airport

Project Number: 3-31-0019-017-2023

Description of Work: Construct 8-place T-hangar

Application

Title 2 CFR § 200.112 and § 1201.112 address Federal Aviation Administration (FAA) requirements for conflict of interest. As a condition of eligibility under the Airport Improvement Program (AIP), sponsors must comply with FAA policy on conflict of interest. Such a conflict would arise when any of the following have a financial or other interest in the firm selected for award:

- a) The employee, officer or agent,
- b) Any member of his immediate family,
- c) His or her partner, or
- d) An organization which employs, or is about to employ, any of the above.

Selecting "Yes" represents sponsor or sub-recipient acknowledgement and confirmation of the certification statement. Selecting "No" represents sponsor or sub-recipient disclosure that it cannot fully comply with the certification statement. If "No" is selected, provide support information explaining the negative response as an attachment to this form. This includes whether the sponsor has established standards for financial interest that are not substantial or unsolicited gifts are of nominal value (2 CFR § 200.318(c)). The term "will" means Sponsor action taken at appropriate time based on the certification statement focus area, but no later than the end of the project period of performance.

Certification Statements

1. The sponsor or sub-recipient maintains a written standards of conduct governing conflict of interest and the performance of their employees engaged in the award and administration of contracts (2 CFR § 200.318(c)). To the extent permitted by state or local law or regulations, such standards of conduct provide for penalties, sanctions, or other disciplinary actions for violations of such standards by the sponsor's and sub-recipient's officers, employees, or agents, or by contractors or their agents.

Yes No

2. The sponsor's or sub-recipient's officers, employees or agents have not and will not solicit or accept gratuities, favors or anything of monetary value from contractors, potential contractors, or parties to sub-agreements (2 CFR § 200.318(c)).

Yes No

3. The sponsor or sub-recipient certifies that is has disclosed and will disclose to the FAA any known potential conflict of interest (2 CFR § 1200.112).

Yes No

Attach documentation clarifying any above item marked with "no" response.

Sponsor's Certification

I certify, for the project identified herein, responses to the forgoing items are accurate as marked and have the explanation for any item marked "no" is correct and complete.

Executed on this 21 day of February, 2023 .

Name of Sponsor: City of Columbus

Name of Sponsor's Authorized Official: Janelle Kline

Title of Sponsor's Authorized Official: City Clerk

Signature of Sponsor's Authorized Official: _____



I declare under penalty of perjury that the foregoing is true and correct. I understand that knowingly and willfully providing false information to the federal government is a violation of 18 USC § 1001 (False Statements) and could subject me to fines, imprisonment, or both.

Drug-Free Workplace Airport Improvement Program Sponsor Certification

Sponsor: City of Columbus

Airport: Columbus Municipal Airport

Project Number: 3-31-0019-017-2023

Description of Work: Construct 8-place T-hangar

Application

49 USC § 47105(d) authorizes the Secretary to require certification from the sponsor that it will comply with the statutory and administrative requirements in carrying out a project under the Airport Improvement Program (AIP). General requirements on the drug-free workplace within federal grant programs are described in 2 CFR part 182. Sponsors are required to certify they will be, or will continue to provide, a drug-free workplace in accordance with the regulation. The AIP project grant agreement contains specific assurances on the Drug-Free Workplace Act of 1988.

Certification Statements

Except for certification statements below marked as not applicable (N/A), this list includes major requirements of the construction project. Selecting "Yes" represents sponsor acknowledgement and confirmation of the certification statement. The term "will" means Sponsor action taken at appropriate time based on the certification statement focus area, but no later than the end of the project period of performance. This list is not comprehensive and does not relieve the sponsor from fully complying with all applicable statutory and administrative standards. The source of the requirement is referenced within parenthesis.

1. A statement has been or will be published prior to commencement of project notifying employees that the unlawful manufacture, distribution, dispensing, possession, or use of a controlled substance is prohibited in the sponsor's workplace, and specifying the actions to be taken against employees for violation of such prohibition (2 CFR § 182.205).

Yes No N/A

2. An ongoing drug-free awareness program (2 CFR § 182.215) has been or will be established prior to commencement of project to inform employees about:

- a. The dangers of drug abuse in the workplace;
- b. The sponsor's policy of maintaining a drug-free workplace;
- c. Any available drug counseling, rehabilitation, and employee assistance programs; and
- d. The penalties that may be imposed upon employees for drug abuse violations occurring in the workplace.

Yes No N/A

3. Each employee to be engaged in the performance of the work has been or will be given a copy of the statement required within item 1 above prior to commencement of project (2 CFR § 182.210).

Yes No N/A

4. Employees have been or will be notified in the statement required by item 1 above that, as a condition employment under the grant (2 CFR § 182.205(c)), the employee will:

- a. Abide by the terms of the statement; and
- b. Notify the employer in writing of his or her conviction for a violation of a criminal drug statute occurring in the workplace no later than five calendar days after such conviction.

Yes No N/A

5. The Federal Aviation Administration (FAA) will be notified in writing within 10 calendar days after receiving notice under item 4b above from an employee or otherwise receiving actual notice of such conviction (2 CFR § 182.225). Employers of convicted employees must provide notice, including position title of the employee, to the FAA (2 CFR § 182.300).

Yes No N/A

6. One of the following actions (2 CFR § 182.225(b)) will be taken within 30 calendar days of receiving a notice under item 4b above with respect to any employee who is so convicted:

- a. Take appropriate personnel action against such an employee, up to and including termination, consistent with the requirements of the Rehabilitation Act of 1973, as amended; and
- b. Require such employee to participate satisfactorily in drug abuse assistance or rehabilitation programs approved for such purposes by a federal, state, or local health, law enforcement, or other appropriate agency.

Yes No N/A

7. A good faith effort will be made, on a continuous basis, to maintain a drug-free workplace through implementation of items 1 through 6 above (2 CFR § 182.200).

Yes No N/A

Site(s) of performance of work (2 CFR § 182.230):

Location 1

Name of Location: Columbus Municipal Airport

Address: 1308 Bill Babka Dr, Columbus NE 68602-1677

Location 2 (if applicable)

Name of Location:

Address:

Location 3 (if applicable)

Name of Location:

Address:

Attach documentation clarifying any above item marked with a "No" response.

Sponsor's Certification

I certify, for the project identified herein, responses to the forgoing items are accurate as marked and additional documentation for any item marked "no" is correct and complete.

Executed on this 21 day of February, 2023.

Name of Sponsor: City of Columbus

Name of Sponsor's Authorized Official: Janelle Kline

Title of Sponsor's Authorized Official: City Clerk

Signature of Sponsor's Authorized Official:  _____

I declare under penalty of perjury that the foregoing is true and correct. I understand that knowingly and willfully providing false information to the federal government is a violation of 18 USC § 1001 (False Statements) and could subject me to fines, imprisonment, or both.

Selection of Consultants

Airport Improvement Program Sponsor Certification

Sponsor: City of Columbus

Airport: Columbus Municipal Airport

Project Number: 3-31-0019-017-2023

Description of Work: Construct 8-place T-hangar

Application

49 USC § 47105(d) authorizes the Secretary to require certification from the sponsor that it will comply with the statutory and administrative requirements in carrying out a project under the Airport Improvement Program (AIP). General requirements for selection of consultant services within federal grant programs are described in 2 CFR §§ 200.317-200.326. Sponsors may use other qualifications-based procedures provided they are equivalent to standards of Title 40 chapter 11 and FAA Advisory Circular 150/5100-14, Architectural, Engineering, and Planning Consultant Services for Airport Grant Projects.

Certification Statements

Except for certification statements below marked as not applicable (N/A), this list includes major requirements of the construction project. Selecting "Yes" represents sponsor acknowledgement and confirmation of the certification statement. The term "will" means Sponsor action taken at appropriate time based on the certification statement focus area, but no later than the end of the project period of performance. This list is not comprehensive and does not relieve the sponsor from fully complying with all applicable statutory and administrative standards. The source of the requirement is referenced within parenthesis.

1. Sponsor acknowledges their responsibility for the settlement of all contractual and administrative issues arising out of their procurement actions (2 CFR § 200.318(k)).
 Yes No N/A

2. Sponsor procurement actions ensure or will ensure full and open competition that does not unduly limit competition (2 CFR § 200.319).
 Yes No N/A

3. Sponsor has excluded or will exclude any entity that develops or drafts specifications, requirements, or statements of work associated with the development of a request-for-qualifications (RFQ) from competing for the advertised services (2 CFR § 200.319).
 Yes No N/A

4. The advertisement describes or will describe specific project statements-of-work that provide clear detail of required services without unduly restricting competition (2 CFR § 200.319).
 Yes No N/A
5. Sponsor has publicized or will publicize a RFQ that:
a. Solicits an adequate number of qualified sources (2 CFR § 200.320(d)); and
b. Identifies all evaluation criteria and relative importance (2 CFR § 200.320(d)).
 Yes No N/A
6. Sponsor has based or will base selection on qualifications, experience, and disadvantaged business enterprise participation with price not being a selection factor (2 CFR § 200.320(d)).
 Yes No N/A
7. Sponsor has verified or will verify that agreements exceeding \$25,000 are not awarded to individuals or firms suspended, debarred or otherwise excluded from participating in federally assisted projects (2 CFR §180.300).
 Yes No N/A
8. A/E services covering multiple projects: Sponsor has agreed to or will agree to:
a. Refrain from initiating work covered by this procurement beyond five years from the date of selection (AC 150/5100-14); and
b. Retain the right to conduct new procurement actions for projects identified or not identified in the RFQ (AC 150/5100-14).
 Yes No N/A
9. Sponsor has negotiated or will negotiate a fair and reasonable fee with the firm they select as most qualified for the services identified in the RFQ (2 CFR § 200.323).
 Yes No N/A
10. The Sponsor's contract identifies or will identify costs associated with ineligible work separately from costs associated with eligible work (2 CFR § 200.302).
 Yes No N/A
11. Sponsor has prepared or will prepare a record of negotiations detailing the history of the procurement action, rationale for contract type and basis for contract fees (2 CFR §200.318(i)).
 Yes No N/A
12. Sponsor has incorporated or will incorporate mandatory contract provisions in the consultant contract for AIP-assisted work (49 U.S.C. Chapter 471 and 2 CFR part 200 Appendix II)
 Yes No N/A

13. For contracts that apply a time-and-material payment provision (also known as hourly rates, specific rates of compensation, and labor rates), the Sponsor has established or will establish:

- a. Justification that there is no other suitable contract method for the services (2 CFR §200.318(j));
- b. A ceiling price that the consultant exceeds at their risk (2 CFR §200.318(j)); and
- c. A high degree of oversight that assures consultant is performing work in an efficient manner with effective cost controls in place 2 CFR §200.318(j).

Yes No N/A

14. Sponsor is not using or will not use the prohibited cost-plus-percentage-of-cost (CPPC) contract method. (2 CFR § 200.323(d)).

Yes No N/A

Attach documentation clarifying any above item marked with "no" response.

Sponsor's Certification

I certify, for the project identified herein, responses to the forgoing items are accurate as marked and additional documentation for any item marked "no" is correct and complete.

I declare under penalty of perjury that the foregoing is true and correct. I understand that knowingly and willfully providing false information to the federal government is a violation of 18 USC § 1001 (False Statements) and could subject me to fines, imprisonment, or both.

Executed on this 21 day of February, 2023 .

Name of Sponsor: City of Columbus

Name of Sponsor's Authorized Official: Janelle Kline

Title of Sponsor's Authorized Official: City Clerk

Signature of Sponsor's Authorized Official: _____

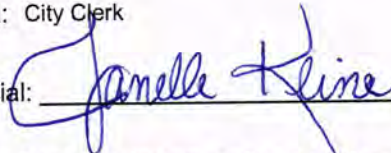

I declare under penalty of perjury that the foregoing is true and correct. I understand that knowingly and willfully providing false information to the federal government is a violation of 18 USC § 1001 (False Statements) and could subject me to fines, imprisonment, or both.

Project Plans and Specifications

Airport Improvement Program Sponsor Certification

Sponsor: City of Columbus

Airport: Columbus Municipal Airport

Project Number: 3-31-0019-017-2023

Description of Work: Construct 8-place T-hangar

Application

49 USC § 47105(d) authorizes the Secretary to require certification from the sponsor that it will comply with the statutory and administrative requirements in carrying out a project under the Airport Improvement Program (AIP). Labor and civil rights standards applicable to AIP are established by the Department of Labor (www.dol.gov). AIP Grant Assurance C.1—General Federal Requirements identifies applicable federal laws, regulations, executive orders, policies, guidelines and requirements for assistance under AIP. A list of current advisory circulars with specific standards for procurement, design or construction of airports, and installation of equipment and facilities is referenced in standard airport sponsor Grant Assurance 34 contained in the grant agreement.

Certification Statements

Except for certification statements below marked as not applicable (N/A), this list includes major requirements of the construction project. Selecting "Yes" represents sponsor acknowledgement and confirmation of the certification statement. The term "will" means Sponsor action taken at appropriate time based on the certification statement focus area, but no later than the end of the project period of performance. This list is not comprehensive and does not relieve the sponsor from fully complying with all applicable statutory and administrative standards. The source of the requirement is referenced within parenthesis.

1. The plans and specifications were or will be prepared in accordance with applicable federal standards and requirements, so that no deviation or modification to standards set forth in the advisory circulars, or FAA-accepted state standard, is necessary other than those explicitly approved by the Federal Aviation Administration (FAA) (14 USC § 47105).
 Yes No N/A

2. Specifications incorporate or will incorporate a clear and accurate description of the technical requirement for the material or product that does not contain limiting or proprietary features that unduly restrict competition (2 CFR §200.319).
 Yes No N/A

3. The development that is included or will be included in the plans is depicted on the current airport layout plan as approved by the FAA (14 USC § 47107).
- Yes No N/A
4. Development and features that are ineligible or unallowable for AIP funding have been or will be omitted from the plans and specifications (FAA Order 5100.38, par. 3-43).
- Yes No N/A
5. The specification does not use or will not use "brand name" or equal to convey requirements unless sponsor requests and receives approval from the FAA to use brand name (FAA Order 5100.38, Table U-5).
- Yes No N/A
6. The specification does not impose or will not impose geographical preference in their procurement requirements (2 CFR §200.319(b) and FAA Order 5100.38, Table U-5).
- Yes No N/A
7. The use of prequalified lists of individuals, firms or products include or will include sufficient qualified sources that ensure open and free competition and that does not preclude potential entities from qualifying during the solicitation period (2 CFR §319(d)).
- Yes No N/A
8. Solicitations with bid alternates include or will include explicit information that establish a basis for award of contract that is free of arbitrary decisions by the sponsor (2 CFR § 200.319(a)(7)).
- Yes No N/A
9. Concurrence was or will be obtained from the FAA if Sponsor incorporates a value engineering clause into the contract (FAA Order 5100.38, par. 3-57).
- Yes No N/A
10. The plans and specifications incorporate or will incorporate applicable requirements and recommendations set forth in the federally approved environmental finding (49 USC §47106(c)).
- Yes No N/A
11. The design of all buildings comply or will comply with the seismic design requirements of 49 CFR § 41.120. (FAA Order 5100.38d, par. 3-92)
- Yes No N/A
12. The project specification include or will include process control and acceptance tests required for the project by as per the applicable standard:
- a. Construction and installation as contained in Advisory Circular (AC) 150/5370-10.
- Yes No N/A

b. Snow Removal Equipment as contained in AC 150/5220-20.

Yes No N/A

c. Aircraft Rescue and Fire Fighting (ARFF) vehicles as contained in AC 150/5220-10.

Yes No N/A

13. For construction activities within or near aircraft operational areas(AOA):

a. The Sponsor has or will prepare a construction safety and phasing plan (CSPP) conforming to Advisory Circular 150/5370-2.

b. Compliance with CSPP safety provisions has been or will be incorporated into the plans and specifications as a contractor requirement.

c. Sponsor will not initiate work until receiving FAA's concurrence with the CSPP (FAA Order 5100.38, Par. 5-29).

Yes No N/A

14. The project was or will be physically completed without federal participation in costs due to errors and omissions in the plans and specifications that were foreseeable at the time of project design (49 USC §47110(b)(1) and FAA Order 5100.38d, par. 3-100).

Yes No N/A

Attach documentation clarifying any above item marked with "No" response.

Sponsor's Certification

I certify, for the project identified herein, responses to the forgoing items are accurate as marked and additional documentation for any item marked "no" is correct and complete.

Executed on this 21 day of February, 2023 .

Name of Sponsor: City of Columbus

Name of Sponsor's Authorized Official: Janelle Kline

Title of Sponsor's Authorized Official: City Clerk

Signature of Sponsor's Authorized Official: _____



I declare under penalty of perjury that the foregoing is true and correct. I understand that knowingly and willfully providing false information to the federal government is a violation of 18 USC § 1001 (False Statements) and could subject me to fines, imprisonment, or both.

Equipment and Construction Contracts Airport Improvement Sponsor Certification

Sponsor: City of Columbus

Airport: Columbus Municipal Airport

Project Number: 3-31-0019-017-2023

Description of Work: Construct 8-place T-hangar

Application

49 USC § 47105(d) authorizes the Secretary to require certification from the sponsor that it will comply with the statutory and administrative requirements in carrying out a project under the Airport Improvement Program (AIP). General procurement standards for equipment and construction contracts within Federal grant programs are described in 2 CFR §§ 200.317-200.326. Labor and Civil Rights Standards applicable to the AIP are established by the Department of Labor (www.dol.gov) AIP Grant Assurance C.1—General Federal Requirements identifies all applicable Federal Laws, regulations, executive orders, policies, guidelines and requirements for assistance under the AIP. Sponsors may use state and local procedures provided the procurement conforms to these federal standards.

This certification applies to all equipment and construction projects. Equipment projects may or may not employ laborers and mechanics that qualify the project as a "covered contract" under requirements established by the Department of Labor requirements. Sponsor shall provide appropriate responses to the certification statements that reflect the character of the project regardless of whether the contract is for a construction project or an equipment project.

Certification Statements

Except for certification statements below marked as not applicable (N/A), this list includes major requirements of the construction project. Selecting "Yes" represents sponsor acknowledgement and confirmation of the certification statement. The term "will" means Sponsor action taken at appropriate time based on the certification statement focus area, but no later than the end of the project period of performance. This list is not comprehensive and does not relieve the sponsor from fully complying with all applicable statutory and administrative standards. The source of the requirement is referenced within parenthesis.

1. A written code or standard of conduct is or will be in effect prior to commencement of the project that governs the performance of the sponsor's officers, employees, or agents in soliciting, awarding and administering procurement contracts (2 CFR § 200.318).

Yes No N/A

2. For all contracts, qualified and competent personnel are or will be engaged to perform contract administration, engineering supervision, construction inspection, and testing (Grant Assurance C.17).
- Yes No N/A
3. Sponsors that are required to have a Disadvantage Business Enterprise (DBE) program on file with the FAA have included or will include clauses required by Title VI of the Civil Rights Act and 49 CFR Part 26 for Disadvantaged Business Enterprises in all contracts and subcontracts.
- Yes No N/A
4. Sponsors required to have a DBE program on file with the FAA have implemented or will implement monitoring and enforcement measures that:
- a. Ensure work committed to Disadvantaged Business Enterprises at contract award is actually performed by the named DBEs (49 CFR § 26.37(b));
 - b. Include written certification that the sponsor has reviewed contract records and has monitored work sites for performance by DBE firms (49 CFR § 26.37(b)); and
 - c. Provides for a running tally of payments made to DBE firms and a means for comparing actual attainments (i.e. payments) to original commitments (49 CFR § 26.37(c)).
- Yes No N/A
5. Sponsor procurement actions using the competitive sealed bid method (2 CFR § 200.320(c)). was or will be:
- a. Publicly advertised, allowing a sufficient response time to solicit an adequate number of interested contractors or vendors;
 - b. Prepared to include a complete, adequate and realistic specification that defines the items or services in sufficient detail to allow prospective bidders to respond;
 - c. Publicly opened at a time and place prescribed in the invitation for bids; and
 - d. Prepared in a manner that result in a firm fixed price contract award to the lowest responsive and responsible bidder.
- Yes No N/A
6. For projects the Sponsor proposes to use the competitive proposal procurement method (2 CFR § 200.320(d)), Sponsor has requested or will request FAA approval prior to proceeding with a competitive proposal procurement by submitting to the FAA the following:
- a. Written justification that supports use of competitive proposal method in lieu of the preferred sealed bid procurement method;
 - b. Plan for publicizing and soliciting an adequate number of qualified sources; and
 - c. Listing of evaluation factors along with relative importance of the factors.
- Yes No N/A
7. For construction and equipment installation projects, the bid solicitation includes or will include the current federal wage rate schedule(s) for the appropriate type of work classifications (2 CFR Part 200, Appendix II).
- Yes No N/A

8. Concurrence was or will be obtained from the Federal Aviation Administration (FAA) prior to contract award under any of the following circumstances (Order 5100.38D):
- a. Only one qualified person/firm submits a responsive bid;
 - b. Award is to be made to other than the lowest responsible bidder; and
 - c. Life cycle costing is a factor in selecting the lowest responsive bidder.
- Yes No N/A
9. All construction and equipment installation contracts contain or will contain provisions for:
- a. Access to Records (§ 200.336)
 - b. Buy American Preferences (Title 49 U.S.C. § 50101)
 - c. Civil Rights - General Provisions and Title VI Assurances(41 CFR part 60)
 - d. Federal Fair Labor Standards (29 U.S.C. § 201, et seq)
 - e. Occupational Safety and Health Act requirements (20 CFR part 1920)
 - f. Seismic Safety – building construction (49 CFR part 41)
 - g. State Energy Conservation Requirements - as applicable(2 CFR part 200, Appendix II)
 - h. U.S. Trade Restriction (49 CFR part 30)
 - i. Veterans Preference (49 USC § 47112(c))
- Yes No N/A
10. All construction and equipment installation contracts exceeding \$2,000 contain or will contain the provisions established by:
- a. Davis-Bacon and Related Acts (29 CFR part 5)
 - b. Copeland "Anti-Kickback" Act (29 CFR parts 3 and 5)
- Yes No N/A
11. All construction and equipment installation contracts exceeding \$3,000 contain or will contain a contract provision that discourages distracted driving (E.O. 13513).
- Yes No N/A
12. All contracts exceeding \$10,000 contain or will contain the following provisions as applicable:
- a. Construction and equipment installation projects - Applicable clauses from 41 CFR Part 60 for compliance with Executive Orders 11246 and 11375 on Equal Employment Opportunity;
 - b. Construction and equipment installation - Contract Clause prohibiting segregated facilities in accordance with 41 CFR part 60-1.8;
 - c. Requirement to maximize use of products containing recovered materials in accordance with 2 CFR § 200.322 and 40 CFR part 247; and
 - d. Provisions that address termination for cause and termination for convenience (2 CFR Part 200, Appendix II).
- Yes No N/A

13. All contracts and subcontracts exceeding \$25,000: Measures are in place or will be in place (e.g. checking the System for Award Management) that ensure contracts and subcontracts are not awarded to individuals or firms suspended, debarred, or excluded from participating in federally assisted projects (2 CFR parts 180 and 1200).

Yes No N/A

14. Contracts exceeding the simplified acquisition threshold (currently \$250,000) include or will include provisions, as applicable, that address the following:

- a. Construction and equipment installation contracts - a bid guarantee of 5%, a performance bond of 100%, and a payment bond of 100% (2 CFR § 200.325);
- b. Construction and equipment installation contracts - requirements of the Contract Work Hours and Safety Standards Act (40 USC 3701-3708, Sections 103 and 107);
- c. Restrictions on Lobbying and Influencing (2 CFR part 200, Appendix II);
- d. Conditions specifying administrative, contractual and legal remedies for instances where contractor or vendor violate or breach the terms and conditions of the contract (2 CFR §200, Appendix II); and
- e. All Contracts - Applicable standards and requirements issued under Section 306 of the Clean Air Act (42 USC 7401-7671q), Section 508 of the Clean Water Act (33 USC 1251-1387, and Executive Order 11738.

Yes No N/A

Attach documentation clarifying any above item marked with "No" response.

Sponsor's Certification

I certify, for the project identified herein, responses to the forgoing items are accurate as marked and additional documentation for any item marked "no" is correct and complete.

Executed on this 21 day of February, 2023 .

Name of Sponsor: City of Columbus

Name of Sponsor's Authorized Official: Janelle Kline

Title of Sponsor's Authorized Official: City Clerk

Signature of Sponsor's Authorized Official: _____



I declare under penalty of perjury that the foregoing is true and correct. I understand that knowingly and willfully providing false information to the federal government is a violation of 18 USC § 1001 (False Statements) and could subject me to fines, imprisonment, or both.

Construction Project Final Acceptance Airport Improvement Program Sponsor Certification

Sponsor: City of Columbus

Airport: Columbus Municipal Airport

Project Number: 3-31-0019-017-2023

Description of Work: Construct 8-place T-hangar

Application

49 USC § 47105(d), authorizes the Secretary to require me certification from the sponsor that it will comply with the statutory and administrative requirements in carrying out a project under the Airport Improvement Program. General standards for final acceptance and close out of federally funded construction projects are in 2 CFR § 200.343 – Closeout and supplemented by FAA Order 5100.38. The sponsor must determine that project costs are accurate and proper in accordance with specific requirements of the grant agreement and contract documents.

Certification Statements

Except for certification statements below marked not applicable (N/A), this list includes major requirements of the construction project. Selecting "Yes" represents sponsor acknowledgment and confirmation of the certification statement. The term "will" means Sponsor action taken at appropriate time based on the certification statement focus area, but no later than the end of the project period of performance. This list is not comprehensive and does not relieve the sponsor from fully complying with all applicable statutory and administrative standards. The source of the requirement is referenced within parenthesis.

1. The personnel engaged in project administration, engineering supervision, project inspection, and acceptance testing were or will be determined to be qualified and competent to perform the work (Grant Assurance).
 Yes No N/A
2. Construction records, including daily logs, were or will be kept by the resident engineer/construction inspector that fully document contractor's performance in complying with:
 - a. Technical standards (Advisory Circular (AC) 150/5370-12);
 - b. Contract requirements (2 CFR part 200 and FAA Order 5100.38); and
 - c. Construction safety and phasing plan measures (AC 150/5370-2). Yes No N/A
3. All acceptance tests specified in the project specifications were or will be performed and documented. (AC 150/5370-12).
 Yes No N/A

4. Sponsor has taken or will take appropriate corrective action for any test result outside of allowable tolerances (AC 150/5370-12).
 Yes No N/A
5. Pay reduction factors required by the specifications were applied or will be applied in computing final payments with a summary made available to the FAA (AC 150/5370-10).
 Yes No N/A
6. Sponsor has notified, or will promptly notify the Federal Aviation Administration (FAA) of the following occurrences:
- a. Violations of any federal requirements set forth or included by reference in the contract documents (2 CFR part 200);
 - b. Disputes or complaints concerning federal labor standards (29 CFR part 5); and
 - c. Violations of or complaints addressing conformance with Equal Employment Opportunity or Disadvantaged Business Enterprise requirements (41 CFR Chapter 60 and 49 CFR part 26).
- Yes No N/A
7. Weekly payroll records and statements of compliance were or will be submitted by the prime contractor and reviewed by the sponsor for conformance with federal labor and civil rights requirements as required by FAA and U.S. Department of Labor (29 CFR Part 5).
 Yes No N/A
8. Payments to the contractor were or will be made in conformance with federal requirements and contract provisions using sponsor internal controls that include:
- a. Retaining source documentation of payments and verifying contractor billing statements against actual performance (2 CFR § 200.302 and FAA Order 5100.38);
 - b. Prompt payment of subcontractors for satisfactory performance of work (49 CFR § 26.29);
 - c. Release of applicable retainage upon satisfactory performance of work (49 CFR § 26.29); and
 - d. Verification that payments to DBEs represent work the DBE performed by carrying out a commercially useful function (49 CFR §26.55).
- Yes No N/A
9. A final project inspection was or will be conducted with representatives of the sponsor and the contractor present that ensure:
- a. Physical completion of project work in conformance with approved plans and specifications (Order 5100.38);
 - b. Necessary actions to correct punch list items identified during final inspection are complete (Order 5100.38); and
 - c. Preparation of a record of final inspection and distribution to parties to the contract (Order 5100.38);
- Yes No N/A
10. The project was or will be accomplished without material deviations, changes, or modifications from approved plans and specifications, except as approved by the FAA (Order 5100.38).
 Yes No N/A

11. The construction of all buildings have complied or will comply with the seismic construction requirements of 49 CFR § 41.120.

Yes No N/A

12. For development projects, sponsor has taken or will take the following close-out actions:

- a. Submit to the FAA a final test and quality assurance report summarizing acceptance test results, as applicable (Grant Condition);
- b. Complete all environmental requirements as established within the project environmental determination (Order 5100.38); and
- c. Prepare and retain as-built plans (Order 5100.38).

Yes No N/A

13. Sponsor has revised or will revise their airport layout plan (ALP) that reflects improvements made and has submitted or will submit an updated ALP to the FAA no later than 90 days from the period of performance end date. (49 USC § 47107 and Order 5100.38).

Yes No N/A

Attach documentation clarifying any above item marked with "No" response.

Sponsor's Certification

I certify, for the project identified herein, responses to the forgoing items are accurate as marked and additional documentation for any item marked "no" is correct and complete.

Executed on this 21 day of February, 2023.

Name of Sponsor: City of Columbus

Name of Sponsor's Authorized Official: Janelle Kline

Title of Sponsor's Authorized Official: City Clerk

Signature of Sponsor's Authorized Official: _____

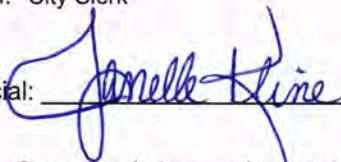

I declare under penalty of perjury that the foregoing is true and correct. I understand that knowingly and willfully providing false information to the federal government is a violation of 18 USC § 1001 (False Statements) and could subject me to fines, imprisonment, or both.

14.C.Resolution No. R23-78 approving Discretionary Capital Improvement Project policy.

Draft

RESOLUTION NO. R23-78

A RESOLUTION OF THE MAYOR AND COUNCIL OF THE CITY OF COLUMBUS, NEBRASKA, ADOPTING THE DISCRETIONARY CAPITAL IMPROVEMENT PROJECT POLICY FOR THE CITY OF COLUMBUS, NEBRASKA, A COPY OF WHICH IS ATTACHED HERETO AND INCORPORATED HEREIN BY THIS REFERENCE.

WHEREAS, the Committee of the Whole reviewed the Discretionary Capital Improvement Project Policy at their meeting on June 5, 2023, and made a recommendation to the mayor and city council that the policy be adopted.

WHEREAS, the City Council adopted the report of the Committee of the Whole at their meeting on June 5, 2023.

NOW, THEREFORE, BE IT RESOLVED BY THE MAYOR AND COUNCIL OF THE CITY OF COLUMBUS, NEBRASKA, that the Discretionary Capital Improvement Project Policy, a copy of which is attached hereto and incorporated herein by this reference, is adopted.

INTRODUCED BY COUNCIL MEMBER _____

PASSED AND ADOPTED THIS ____ DAY OF _____, 2023.

MAYOR

ATTEST:

CITY CLERK

APPROVED AS TO FORM:

CITY ATTORNEY

City of Columbus, Nebraska

Discretionary Capital Improvement Project Policy

This policy establishes guidelines and procedures for processing Discretionary Capital Improvement Projects (DCIP), ensuring the involvement of an elected official sponsor and a member of the staff leadership team in the development and execution of each project. The elected official will serve as the public spokesperson and advocate for the project during open meetings, while the staff members will provide professional expertise, research, and leadership during the project development, planning and implementation process.

1. Establishing Projects:

- 1.1. DCIP will be drawn from the annual capital improvement project list that is developed during the annual budget planning process.
- 1.2. During the annual budget development process each discretionary capital project will have one or more elected official sponsor(s). Any DCIP which fails to gain the support of an elected official will not be included in the City's budget. Each elected official will select and rank which DCIP they would like to sponsor. In order to follow the Open Meetings Act, a quorum of elected officials may not be the sponsor of any one DCIP.
- 1.3. Elected officials may request a capital improvement project be included in the annual capital improvement project list in January of each calendar year.
- 1.4. Establishing project priority for the DCIP will be done by the Mayor and City Council after the final DCIP list is finalized. This will be done by each elected officials ranking all of the discretionary capital improvement projects. (If there are 40 DCIP, they will rank those projects from 1 to 40. 1 being the most desired, 40 being the least desired. Projects with the least cumulative points will have the highest priority. Projects with the most cumulative points will have the lowest priority.)

2. Project Sponsorship:

- 2.1. All discretionary capital improvement projects must have an elected official sponsor who will advocate for and support the project throughout its lifecycle.
- 2.2. The elected official sponsor will collaborate with the staff leadership team to provide the necessary direction, resources, and oversight for the project.
- 2.3. The elected official sponsor will act as the public spokesperson for the project during open meetings, providing updates, answering questions, and representing the project to the public.
- 2.4. The City of Columbus will manage resources on the city's website to educate the public on what elected officials are sponsoring what projects.

- 2.5. The elected official sponsor will work together with staff leadership and the city Communication Manager to educate the public on the project, as the team feels necessary.
3. Staff Leadership Team:
 - 3.1. A member of the staff leadership team will be assigned to each discretionary capital improvement project to provide professional expertise and leadership in its development and execution.
 - 3.2. The staff leadership team member will be responsible for conducting research, following applicable rules and regulations, and leading the planning process for the project.
 - 3.3. The staff leadership team member will collaborate closely with the elected official sponsor to ensure alignment with project goals, objectives, and public interests.
4. Project Development Process:
 - 4.1. The elected official sponsor and the staff leadership team member will work together to define the project scope, objectives, and feasibility.
 - 4.2. The staff leadership team member will conduct research, analyze data, and develop a comprehensive plan for the project, including cost estimates, timelines, and required resources.
 - 4.3. The staff leadership team member will engage with relevant stakeholders, such as community members, government agencies, and other departments, to gather input and address concerns during the planning process. The elected official will join in this engagement when desired.
 - 4.4. The staff leadership team member will prepare project documentation, including reports, proposals, and presentations, for review and approval by appropriate authorities.
5. Execution and Oversight:
 - 5.1. Once the project receives necessary approvals, the staff leadership team member will oversee the implementation of the project plan, ensuring adherence to timelines, budgetary constraints, and quality standards.
 - 5.2. The elected official sponsor will continue to advocate for the project and communicate updates to the public through open meetings, community forums, and other appropriate channels.
 - 5.3. The staff leadership team member will regularly report project progress to the elected official sponsor and provide necessary updates to stakeholders and the public as required in coordination with the city Communication Manager.
 - 5.4. The elected official sponsor and the staff leadership team member will address any issues, challenges, or changes that arise during project execution, ensuring effective resolution and adaptation.
6. Evaluation and Closure:

- 6.1. Upon completion of the discretionary capital improvement project, the staff leadership team member and elected sponsor will complete an evaluation to assess the project's success, outcomes and identify lessons learned, recommendations for future projects.
- 6.2. The project will be officially closed after the elected official sponsor and the staff leadership team member have obtained the necessary approvals, completed required documentation, and ensured proper project handover, as applicable.
7. Policy Review:
 - 7.1. This policy will be reviewed periodically to ensure its effectiveness and relevance, with any necessary updates or modifications implemented as deemed appropriate by the City Council.

This policy aims to establish a structured and collaborative approach for processing discretionary capital improvement projects, facilitating accountability, transparency, and efficient utilization of resources.

15. ORDINANCES ON FIRST READING

15.A. Ordinance No. 23-06 approving addendum to purchase agreement with Great Plains State Bank for purchase of city-owned property at 2419 14 Street to revise purchase price from \$200,000 to \$142,600 to provide for environmental remediation escrow account.



The City of Columbus

RESPONSIBLE • RESPONSIVE • REPUTABLE

Administration Office (402) 562-4232

Fax (402) 563-1380

memorandum

DATE: May 31, 2023
TO: Tara Vasicek, City Administrator
FROM: Jean Van Iperen, Planning & Economic Development Coordinator
RE: Addendum to purchase agreement of old Police Department Building

RECOMMENDATION:

To approve the Ordinance authorizing the addendum to the purchase agreement between the City of Columbus and Great Plains State Bank.

DISCUSSION:

The City of Columbus and Great Plains State Bank entered into an agreement in December 2022 for GPSB to purchase the old Police Station building. The agreement did provide for a renegotiation of purchase price if GPS had a Phase II environmental report done and the findings showed the need for clean up of buried gas tanks, contaminated soil replacement, and installation of water lines resistant to volatile organic compounds.

City Staff and Great Plains State Bank representatives met to discuss the findings and potential costs associated with the clean-up. A recommendation is being made that GPSB pays the City a guaranteed purchase price of \$142,600 for the property with an additional \$46,100 being placed in an escrow account to cover the cost of the removal of the tanks and contaminated soil. Once all invoices for remediation have been paid by GPSB then any remaining money will be given to the city as a final payment. The cost of \$11,300 for the VOC resistant water lines has been subtracted from the original purchase price and will be used by GPSB to cover that additional construction cost.

FISCAL IMPACT:

Possible reduction in sale price of \$57,400 from original purchase price of \$200,000.

ALTERNATIVE:

Not approve the addendum.

SIGNATURE:

By:

Approved by:



Draft

ORDINANCE NO. 23-06

AN ORDINANCE OF THE MAYOR AND COUNCIL OF THE CITY OF COLUMBUS, NEBRASKA, APPROVING THE ADDENDUM TO THE PURCHASE AGREEMENT DATED ON OR ABOUT DECEMBER 5, 2022, BETWEEN THE CITY OF COLUMBUS AND GREAT PLAINS STATE BANK, A COPY OF WHICH IS ATTACHED HERETO AND INCORPORATED HEREIN BY THIS REFERENCE; TO AUTHORIZE THE MAYOR TO EXECUTE THE SAME ON BEHALF OF THE CITY; AND TO PROVIDE FOR THE PUBLICATION OF THIS ORDINANCE IN PAMPHLET FORM.

WHEREAS, the City of Columbus and Great Plains State Bank entered into a Purchase Agreement dated on or about December 5, 2022, for the sale and purchase of the City's former Police Department Building; and

WHEREAS, said Purchase Agreement was approved by the City via Ordinance No. 22-30; and

WHEREAS, Paragraph 8 of the Purchase Agreement, titled "Potential Buried Gas Tank/Line", allowed Great Plains State Bank to perform environmental assessments on the real property and if environmental remediation was found to be recommended, then Great Plains State Bank was allowed to renegotiate the payment terms and provisions; and

WHEREAS, the parties are desirous of amending the Purchase Agreement by way of an Addendum.

BE IT ORDAINED BY THE MAYOR AND COUNCIL OF THE CITY OF COLUMBUS, NEBRASKA, that the Addendum to the Purchase Agreement dated on or about December 5, 2022, between the City of Columbus and Great Plains State Bank, a copy of which is attached hereto and incorporated herein by this reference, is hereby approved and the mayor is authorized, directed, and empowered to execute the same on behalf of the City of Columbus.

This ordinance shall become effective immediately upon and be in full force and effect after its passage, adoption, and publication as provided by law. Publication shall be in pamphlet form as authorized by §16-405 of Nebraska Revised Statutes with distribution to be made by making copies available to the public upon request at the office of the city clerk.

INTRODUCED BY COUNCIL MEMBER _____

PASSED AND ADOPTED THIS ____ DAY OF _____, 2023.

MAYOR

ATTEST:

CITY CLERK

APPROVED AS TO FORM:

CITY ATTORNEY

**ADDENDUM TO:
Purchase Agreement Dated
On Or about 12/5/2022 Between
The City of Columbus and
Great Plains State Bank**

WHEREAS, the City of Columbus (hereinafter referred to as “Seller”) and Great Plains State Bank (hereinafter referred to as “Buyer”) entered into a Purchase Agreement dated on or about December 5, 2022 (hereinafter referred to as the “Underlying Agreement”); and

WHEREAS, said Underlying Agreement was approved by the City via Ordinance No. 22-30; and

WHEREAS, Paragraph 8 of the Underlying Agreement, titled “Potential Buried Gas Tank/Line”, contains the following provision:

If the Phase 2 environmental site assessment is conducted and it shows the need for extensive clean-up such as tank removal, contaminated soils replacement, groundwater treatment, and/or any associated monitoring, then Buyer shall have the right to renegotiate with Seller as to the purchase price and/or cost allocation of such clean-up. In this situation, if a revised purchase price and/or cost alteration is not agreed to then this contract shall become void; if a revised purchase price and/or cost alteration is agreed to then the parties shall enter into a written contract amendment providing those terms. As part of said renegotiation process Buyer will acquire a cost estimate from a professional for any needed clean up and provide such estimate to Seller.

and

WHEREAS, the environmental assessments preformed have showed that there are up to four buried tanks and remediation is need to remove said tanks, and thus Buyer desires a new purchase price; and

WEHREAS, Seller and Buyer agree to amend the underlying agreement as stated herein.

NOW, THEREFORE, in consideration of the foregoing, and the mutual benefits provided by the Underlying Agreement and this Addendum, the Agreement is hereby amended as follows:

1. This Addendum hereby amends Paragraph 2, “Purchase Price and Payments” of the

Underlying Agreement to read as follows:

PURCHASE PRICE AND PAYMENTS. Buyer shall pay the sum of One Hundred Forty-Two Thousand And Six Hundred Dollars (\$142,600) to the Seller. Buyer shall also pay to Seller any amount that may be left over in the environmental remediation escrow account that is further described in Paragraph 8 of this Agreement. Buyer agrees in consideration of purchase of the Property to pay such sum in the following manner:

- One Hundred Forty-Two Thousand And Six Hundred Dollars (\$142,600) on the date of closing; and
- The amount left over/remaining, if any, in the environmental remediation escrow account upon completion of the environmental remediation as more specifically described in Paragraph 8 of this Agreement.

2. This Addendum hereby amends Paragraph 8, “Potential Buried Gas Tank/Line” of the

Underlying Agreement to read as follows:

POTENTIAL BURIED GAS TANKS/LINES. Seller has informed Buyer, and Buyer specifically acknowledges and accepts, that there may be buried gas tanks/lines underneath the Property, or a portion thereof, as in the past the Property saw use as a gas station (prior to Seller’s ownership). Seller makes no warranties or representations as to this actual existence and/or condition of the potential buried gas tanks/lines or any associated environmental implications of such. Upon closing, unless otherwise agreed to in writing as provided herein, Buyer hereby solely assumes all risks and responsibilities regarding exposure to, environmental effects thereof, and the financial costs of removal and cleanup of said potential buried gas tanks/lines.

Buyer, at its sole discretion and sole expense, elected to conduct environmental site assessments of the Property. The environmental assessments showed that there are potentially up to four buried tanks/lines at the Property. The environmental remediation that is being recommend consists of the following items:

- 1) Preparation of a Material Management Plan (estimated cost \$3,000)
- 2) Potential Environmental Services – on call observation services including sampling, field oversight, and waste profiling (estimated cost \$10,000)
- 3) Potential Disposal of Contaminated Soil – haul and dispose of at landfill (estimated 90 tons at \$90 per ton; estimated cost \$8,100)

- 4) Additional Cost to Install Water Lines Resistant to VOCs (estimated cost \$11,300)
- 5) Removal of Tanks (potentially up to four 10,000-gallon tanks; estimated cost \$20,000)
- 6) Fill From Tank Removal (estimated cost \$5,000)

The Parties agree that for the aforementioned environmental remediation that:

- For items 1, 2, 3, 5 and 6 listed above that:
 - o Buyer shall place Forty-Six Thousand One Hundred Dollars (\$46,100) into an escrow account to be used to pay for the said estimated costs.
 - o Any amount that is not used and which is leftover in said escrow account after paying for those environmental remediation costs shall then be turned over to the Seller as additional consideration in excess of the purchase price of the Property listed in Paragraph 2 of this Agreement.
 - o Should these environmental remediation costs exceed the aforementioned Forty-Six Thousand One Hundred Dollars (\$46,100) then Buyer shall be solely responsible for those overages and additional costs.
 - o Buyer shall provide copies of the actual environmental remediation invoices so that Seller may verify the actual expenses/costs incurred.
- For item 4 listed above:
 - o Buyer shall at its own expense cover the cost of installing a volatile organic compounds (VOC) resistant water line to protect the water supply from other possible vapor contamination.
- Any other environmental remediation, including any and all costs/expenses relating thereto, that is needed or desired shall be the sole responsibility of Buyer.
- Buyer is responsible for paying any and all contractors involved in performing any environmental remediation services.

3. This Addendum shall be attached to and shall become a part of the Agreement.
4. The Addendum and shall be effective as of the signature date of each Party.
5. All terms and conditions of the Underlying Agreement not otherwise amended or altered by this Addendum shall remain in full force and effect.

****Remainder of Page Left Intentionally Blank****

IN WITNESS WHEREOF, the Seller executed this Agreement effective this _____ day of _____, 2023:

City of Columbus:

By: James B. Bulkley, as Mayor of and
on behalf of the City of Columbus

ATTEST:

CITY CLERK

APPROVED AS TO FORM:

CITY ATTORNEY

IN WITNESS WHEREOF, the Buyer has executed this Agreement effective this _____ day of _____, 2023:

Great Plains State Bank:

By: Richard Chochon, as President and
CEO of and authorized agent for Great
Plains State Bank

STATE OF NEBRASKA)
)ss.
COUNTY OF PLATTE)

Before me, a notary public, qualified for said county, personally came Richard Chochon, as President and CEO of and authorized agent for Great Plains State Bank, known to me to be the identical person who signed the foregoing Purchase Agreement and acknowledged the execution thereof to be his voluntary act and deed.

Dated this ___ day of _____, 2023.

Notary Public

STATE OF NEBRASKA)
)ss.
COUNTY OF PLATTE)

Before me, a notary public, qualified for said county, personally came James B. Bulkley, as Mayor of and on behalf of the City of Columbus, a Municipal Corporation, known to me to be the identical person who signed the foregoing Purchase Agreement and acknowledged the execution thereof to be his voluntary act and deed.

Dated this ___ day of _____, 2023.

Notary Public

***** REMAINDER OF PAGE LEFT INTENTIONALLY BLANK *****

16. ORDINANCES ON SECOND READING

16.A. Ordinance No. 23-04 amending Sections 92.02 and 92.03 of Chapter 92 of Title IV of Columbus City Code to define scrapping and declare scrapping in residential zones as a nuisance.

ORDINANCE NO. 23-04

AN ORDINANCE OF THE MAYOR AND COUNCIL OF THE CITY OF COLUMBUS, NEBRASKA, AMENDING SECTIONS 92.02 AND 92.03 OF CHAPTER 92 OF TITLE IX OF ORDINANCE NO. 05-47 (COLUMBUS CITY CODE) TO DEFINE SCRAPPING AND DECLARE SCRAPPING IN RESIDENTIAL ZONES AS NUISANCES; REPEALING ALL ORDINANCES OR PORTIONS THEREOF IN CONFLICT HEREWITH; PROVIDING FOR AN EFFECTIVE DATE; AND PROVIDING FOR THE PUBLICATION OF THIS ORDINANCE IN PAMPHLET FORM.

WHEREAS, Neb. Rev. Stat. § 18-1720(1) states that “All cities and villages in this state may by ordinance define, regulate, suppress, and prevent nuisances, declare what constitutes a nuisance, and abate and remove such nuisances. Every city and village may exercise such power and authority within its corporate limits and extraterritorial zoning jurisdiction”; and

WHEREAS, Columbus’ municipal code regulates nuisances; and

WHEREAS, the City Council desires to amend the City Code to declare the practices of scrapping in residential areas to be a nuisance.

NOW, THEREFORE, BE IT ORDAINED BY THE MAYOR AND COUNCIL OF THE CITY OF COLUMBUS, NEBRASKA:

Section 1. That Section 92.02 of Chapter 92 of Title IX of the Columbus City Code be amended and revised to read as follows:

§ 92.02 DEFINITIONS.

For the purpose of this chapter, the following definitions shall apply unless the context clearly indicates or requires a different meaning.

CODE ENFORCEMENT OFFICIAL. As used in this subchapter shall be the City’s Community Development Director, and/or his or her designated representative.

EXCAVATION. Any activity in which earth, rock, or other material in or on the ground is moved or otherwise displaced by means of tools, equipment, or explosives and shall include grading, trenching, digging, ditching, drilling, augering, tunneling, scraping, and cable or pipe plowing or driving but shall not include:

- (1) Normal maintenance of roads if the maintenance does not change the original road grade and does not involve the road ditch;
- (2) Tilling of soil and gardening for seeding and other agricultural purposes;
- (3) Digging of graves or in landfills in planned locations;
- (4) Maintenance or rebuilding of railroad track or facilities located on a railroad right-of-way by the railroad company or its contractors

when such maintenance or rebuilding does not change the track grade; or

(5) Hand digging around the base of a pole for pole inspection as part of suitable barriers, and which are not marked by warning lights during the hours of darkness.

NUISANCE. Any condition which:

(1) Injures or endangers the health, safety, or welfare of the public;

(2) Unlawfully interferes with, obstructs, or tends to obstruct, or renders dangerous for passage, any public or private street, highway, sidewalk, stream, ditch, or drainage way;

(3) By reason of lack of sufficient or adequate maintenance of the property, and/or being vacant, any of which depreciates the enjoyment and use of the property in the immediate vicinity to such an extent that it is harmful to the community in which the property is situated or such condition exists;

(4) By reason of being a fire hazard, as determined by the Nebraska State Fire Marshal or the designated representative;

(5) By reason of being unsafe for occupancy, for use on, in, upon, about or around the aforesaid property, as determined by the City Building Inspector or City Engineer; or

(6) By reason of deterioration or decay becomes rodent infested, or which becomes a place frequented by trespassers and transients seeking a temporary shelter or hideout;

(7) Maintaining a **NUISANCE** by act or by failure to perform a legal duty, intentionally causing or permitting a **NUISANCE** to exist;

(8) Permitting a **NUISANCE** to exist is knowingly permitting lots, parcels, or pieces of real property under the control of the offender, including the streets and alleys in front of and abutting such lots and pieces of land to be used or allowed to remain in such condition as to allow a **NUISANCE** condition to exist;

(9) No person shall permit land to be covered with or contain refuse or debris resulting from the construction activities or the demolishing of a building, which refuse or debris has remained on the land for more than:

(a) Thirty days after the completion of the construction activities or demolition work; or

(b) Six months after the permit for such activity or work was granted, whichever is soonest.

PERSON IN CHARGE OF PROPERTY. An agent, occupant, lessee, contract purchaser, or other person having possession or control of property or the supervision of any construction project.

PERSON RESPONSIBLE FOR ABATING NUISANCE.

(1) The owner.

(2) The person in charge of the property.

(3) The person who caused to come into or continue in existence a nuisance, as defined in this subchapter, or another ordinance of this City.

PUBLIC PLACE. A building, way, place, or accommodation, whether publicly or privately owned, open and available to the general public.

SCRAPPING. Continuous receiving, collecting, reprocessing, and/or storing old, broken, damaged, discarded, or scrap copper, brass, dismantled or wrecked automobiles, or parts thereof, iron, steel, or other old scrap, ferrous or nonferrous material, and metal scraps, including aluminum scraps, metals, used bicycles or household appliances, for the purpose of storing, selling, trading, or dealing in scrap.

Section 2. That Section 92.03 of Chapter 92 of Title IX of the Columbus City Code be amended and revised to read as follows:

§ 92.03 ILLUSTRATIVE ENUMERATION.

The maintaining or permitting to be or remain on any public or private property of any of the following conditions is hereby declared to be and constitute a nuisance; provided, however, this enumeration shall not be deemed or construed to be conclusive, limiting or restrictive:

(A) Weeds and noxious vegetation when such growth reaches 12 inches in height.

(B) Placement, storage, or accumulation of garbage, rubbish, trash, refuse, junk and other materials, metals, plumbing fixtures, appliances, auto parts, junked, wrecked or inoperative vehicles, lumber or other litter and furniture, stuffed furniture, clothing or other household items which creates an unsightly appearance. This section applies without limitation to all areas of land within the corporate city limits of Columbus zoned for residential purposes, and whether or not the building, land or property is occupied by human beings.

(C) Any condition which provides harborage for rats, mice, and other vermin.

(D) All disagreeable or noxious odors and stenches, as well as the conditions, substances or other causes which give rise to the emission or generation of such odors and stenches, to include, but not be limited to, unwholesome grain, meat, hides, skins, feathers, vegetable matter, or the whole or any part of any dead animal, fowl, or fish.

(E) Privies, vaults, cesspools, dumps, pits, or like places which are not securely protected from flies or rats, or which are foul or malodorous.

(F) The pollution of any public well or cistern, stream, lake, canal, or body of water by sewage, dead animals, industrial wastes, or other substances which are injurious to overland flow or groundwater.

(G) Any activity, operation, or condition which, after being ordered abated, corrected, or discontinued by a lawful order of any agency or officer of the City, continues to be conducted or continues to exist in violation of any title of the City Code, any regulation enacted pursuant to this City Code, any statute of the State, or any violation of Federal law.

(H) Any accumulation of stagnant water permitted or maintained on any lot or piece of ground.

(I) Any vacant or unoccupied structure, which is not secured or is in a condition which allows access by any person.

(J) Attractive nuisances, which include:

(1) Unguarded machinery, equipment, or other devices which are attractive, dangerous, and accessible to children;

(2) Lumber, logs, or pilings placed or stored in a manner so as to be attractive, dangerous, and accessible to children;

(3) Open pit, quarry, cistern, or other excavation without safeguards or barriers to prevent such places from being used by children;

(4) Construction projects will have appropriate safeguards in place to prevent injury or death to playing children; and

(5) It shall be unlawful for any owner, agent, or contractor in charge of a construction or demolition site to permit the accumulation of litter or the growth of grass or weeds in excess of 12 inches before, during or immediately following completion of any construction or demolition project. It shall be the duty of the owner, agent or contractor in charge of a construction site to furnish containers adequate to accommodate flyable or non-flyable debris or trash at areas convenient to construction areas and to maintain and empty the receptacles in such a manner and with such a frequency as to prevent spillage.

(K) Dangerous excavations, which are not guarded by suitable barriers and which are not marked during the hours of darkness.

(L) Graffiti, which shall mean any unauthorized writing, inscription, word, figure, or design which is marked, etched, scratched, drawn, or painted on any structural component of any building, structure or other facility, regardless of the nature of the material used in its application or upon which it is applied.

(M) Stockyards, granaries, mills, pig pens, cattle pens, chicken pens, or any other place, building or enclosure, in which animals or fowl of any kind are confined or on which are stored tankage or any other animal or vegetable matter or on which any animal or vegetable matter, including grain, is being processed, when the places in which animals are confined, or said premises on which the vegetable or animal matter is located, are maintained and kept in such a manner that foul and noxious odors are permitted to emanate therefrom, to the annoyance of inhabitants of the City, or are maintained and kept in such a manner as to be injurious to the public health.

(N) The practice of scrapping by the continuous receiving, storing, reprocessing, and/or collecting of old, broken, damaged, discarded, or scrap copper, brass, dismantled or wrecked automobiles, or parts thereof, iron, steel, or other old scrap, ferrous or nonferrous material, and metal scraps, including aluminum scraps, metals, used bicycles or household

appliances in any Residential Zoning District is unsightly, unhealthy, and constitutes a nuisance to the citizens and residents of this City.

Section 3. This ordinance shall repeal all Ordinances or portions thereof and in conflict herewith.

Section 4. This ordinance shall be in full force and effect from and after its passage, approval, and publication according to law. Publication shall be in pamphlet form as authorized by §16-405 of Nebraska Revised Statutes with distribution to be made by making copies available to the public upon request at the city office.

INTRODUCED BY COUNCIL MEMBER _____

PASSED AND ADOPTED THIS ____ DAY OF _____, 2023

MAYOR

ATTEST:

CITY CLERK

APPROVED AS TO FORM:

CITY ATTORNEY

The City of **Columbus**

MEMORANDUM

DATE: May 9, 2023
FROM: Andy Woehrer, Chief Building and Code Official
TO: Tara Vasicek, City Administrator
RE: Amending City Code Chapter 92 Nuisances

RECOMMENDATION:

I recommend the adoption of the amendment to Chapter 92 of the City Code as it pertains to Scrapping in Residential Districts.

DISCUSSION:

We are amending the City Code to Scrapping and its definition. This deems scrapping as a nuisance and prohibits scrapping in residential zones. Code Enforcement Officials have received continual complaints made against habitual offenders in the recent years. This amendment aims to suppress the act of scrapping where it is not permitted.

ALTERNATIVE:

Stop enforcing scrapping nuisances in the residential zones.

SIGNATURE:

Approved By: Andy J. Woehrer
Andy Woehrer, Chief Building and Code Official

Approved By: Tara Vasicek
Tara Vasicek, City Administrator

17. **ORDINANCES ON THIRD READING - None**
18. **CONSIDERATION OF PAYROLL AND BILLS ON FILE - Included in Consent Agenda.**
19. **UNFINISHED BUSINESS - None**
20. **ADJOURNMENT**