

AGENDA
CITY COUNCIL, YORK, NEBRASKA
Thursday, August 18, 2022
7:00 PM



THE OPEN MEETINGS ACT IS POSTED ON
THE EAST WALL OF THE COUNCIL
CHAMBERS

1. The Open Meetings Act is posted on the East Wall of the Council Chambers
2. Notice of this meeting was published in the York News Times on August 11, 2022
3. Pledge of Allegiance
4. Roll Call
5. Minutes of August 4, 2022
6. Claims of Elected Officials
 - 6.1. Claim for Tony North of North Printing and Office Supply in the amount of \$494.09
 - 6.2. Claim for Jeff Pieper of Pieper's Inc. in the amount of \$307.02
 - 6.3. Claim for Jerry Wilkinson in the amount of \$650.00
7. Claims for the period of August 5, 2022 through August 18, 2022
8. Approve Cash Balances for the month of July 2022
9. Department Activities Reports for the month of July 2022
10. City Administrator Report
11. Consider approval of a Special Designated License application for Sunset Bowl on September 10, 2022 for a Beer Garden during Yorkfest.
12. Additional Special Designated License Applications for York Sip & Stroll, September 29, 2022.
 - 12.1. Greater Area York Chamber of Commerce for:
 - 1) McNeill Floral Company

2) Impulse Salon and Spa

13. Consider approval of #21-DTR-014 Facade Improvement Program to T&J Rentals, 208 E. 4th Street, for outdoor facade, new windows, store front, HVAC, wall partitions, lighting and floorcoverings, in the amount of \$50,000, total project cost \$85000.00
14. Consider approval of #21-DTR-014 Facade Improvement Program to Dose Management LLC, 623 N. Grant Avenue, for paint and tuck pointing, in the amount of \$50,000.00, total project cost \$89,428.00
15. Consider approval of #21-DTR-014 Facade Improvement Program to Slack Auto Supply, LLC - DBA Carquest Auto Parts, 817 N. Lincoln Avenue, for outdoor sign and electrical to support new sign, in the amount of \$17,887.50, total project cost \$23,850.00
16. Third Reading of Ordinance No. 2331 - Annexation for Chris and Aislee Grant
17. First reading of Ordinance No. 2334 - Prescribing Sewer Rates
18. Resolution 2022-16 - Authorize the Mayor to sign the Annual Certification of Program Compliance to the Nebraska Board of Public Roads Classifications and Standards
19. Statement from Derek Dauel regarding food trucks' ability to operate more freely within York -- Permit Process to allow operation on public lots.
20. Consider an application filed by Brandon Skelton to move a house from 715 W. 4th Street to 1007 N. Greenwood Avenue
21. Mayor Appointment:
 - 21.1. Appointment of Chad Mattox to the Anna Bemis Palmer Museum Advisory Board for a term ending July 15, 2025.
22. Adjournment

REGULAR MEETING
CITY COUNCIL – YORK, NEBRAKSA
August 4, 2022
7:00 PM o'clock P.M.

A meeting of the Mayor and City Council of the City of York, Nebraska, was convened in open and public session at 7:00 o'clock p.m. at the Council Chambers.

The Mayor announced that the Open Meetings Act was posted on the East Wall of the Council Chambers.

Mayor: Barry Redfern, Present. Scott Van Esch: Present, Jennifer Sheppard: Present, Matt Wagner: Present, Tony North: Present, Jerry Wilkinson: Absent, Sheila Hubbard: Present, Jeff Pieper: Present, Christi Lones: Present.

Notice of this meeting was given in advance thereof by publication in the York News Times on July 28, 2022, the City's designated method for giving notice, a copy of the proof of publication being attached to these minutes. Notice of this meeting was given to the Mayor and all members of the City Council and a copy of their acknowledgment and receipt of notice and the agenda is attached to these minutes. Availability of the agenda was communicated in advance notice to the Mayor and City Council for this meeting. All proceedings hereafter shown were taken while the convened meeting was open to the attendance of the public.

Minutes

Motion to approve the minutes from July 21, 2022. Ayes with a motion by Sheila Hubbard and a second by Jennifer Sheppard.

Jerry Wilkinson: Absent, Scott Van Esch: Yea, Jennifer Sheppard: Yea, Matt Wagner: Yea, Tony North: Yea, Sheila Hubbard: Yea, Jeff Pieper: Yea, Christi Lones: Yea

Claims of Elected Officials

Motion to approve the claim for Tony North of North Printing and Office Supply in the amount of \$1,555.44. Ayes with a motion by Christi Lones and a second by Jennifer Sheppard.

Jerry Wilkinson: Absent, Scott Van Esch: Yea, Jennifer Sheppard: Yea, Matt Wagner: Yea, Tony North: Abstain (With Conflict), Sheila Hubbard: Yea, Jeff Pieper: Yea, Christi Lones: Yea

Claims

Motion to approve the claims for the period of July 22, 2022 through August 4, 2022. Ayes with a motion by Christi Lones and a second by Jeff Pieper.

Jerry Wilkinson: Absent, Scott Van Esch: Yea, Jennifer Sheppard: Yea, Matt Wagner: Yea, Tony North: Yea, Sheila Hubbard: Yea, Jeff Pieper: Yea, Christi Lones: Yea

City Administrator Report

Dr. Crawford shared that the Finance Committee meets each Wednesday before the Council meeting to go through all of the claims. In the last meeting, Councilmember Wilkinson questioned if the City could get a discount on medical services. Treasurer Thomas always does an outstanding job of following up on questions from the Finance Committee. She spoke with the hospital and the City was able to save \$1,687 on the claims for this period. Councilmember North stated that Treasurer Thomas does an amazing job and the Council agreed. Dr. Crawford also informed the Council about the next phase of the budget. The public hearing will be set for August 25, 2022 and will be voted on at the first meeting in September.

Second reading of Ordinance No. 2331 - Annexation for Chris and Aislee Grant

This was the second reading for the annexation requested by Chris and Aislee Grant; Ordinance No. 2331. The third reading will be on August 18, 2022.

Resolution 2022-15 - City of York Local Emergency Operation Plan
RESOLUTION NO. 2022-15

Council Member North introduced the following Resolution and moved its adoption; seconded by Council Member Wagner.

RESOLVE: That in order to provide for a coordinated response to a disaster or emergency in York County, the City of York and other cities and villages in York County, The York City Council deems it advisable and in the best interests of the community and the County to approve the attached City of York Local Emergency

Operations Plan. Acceptance of this 2022 Local Emergency Operations Plan supersedes all previous approved City of York Local Emergency Operations Plans.

Motion to approve Resolution 2022-15, City of York Local Emergency Operation Plan. Ayes with a motion by Tony North and a second by Matt Wagner.

Jerry Wilkinson: Absent, Scott Van Esch: Yea, Jennifer Sheppard: Yea, Matt Wagner: Yea, Tony North: Yea, Sheila Hubbard: Yea, Jeff Pieper: Yea, Christi Lones: Yea

Mayor Appointments

Motion to appoint Carston Staehr to the Board of Public Works for a term ending June 1, 2025. Ayes with a motion by Jeff Pieper and a second by Sheila Hubbard.

Jerry Wilkinson: Absent, Scott Van Esch: Yea, Jennifer Sheppard: Yea, Matt Wagner: Yea, Tony North: Yea, Sheila Hubbard: Yea, Jeff Pieper: Yea, Christi Lones: Yea

Motion to approve the appointment of Bre Ronne to the Personnel Board for a term ending June 1, 2026. Ayes with a motion by Christi Lones and a second by Sheila Hubbard.

Jerry Wilkinson: Absent, Scott Van Esch: Yea, Jennifer Sheppard: Yea, Matt Wagner: Yea, Tony North: Yea, Sheila Hubbard: Yea, Jeff Pieper: Yea, Christi Lones: Yea

SDL Applications for York Sip & Stroll, September 29, 2022.

Madonna Mogul, with the York Area Chamber of Commerce, gave background on the Special Designated Licenses requests. She stated that both businesses and citizens participating have given positive feedback on moving the event from the spring to the fall. Special designated license applications approved as listed: York County Development Corporation for: 1) 4th Street Boutique, 2) Ameriprise Financial Services, Inc., 3) The Jewelers Vault, 4) Mid America Vision Center, 5)Wagner Decorating, 6) Western Edge; Greater Area York Chamber of Commerce for: 1) Baer's Furniture, 2) Clinch Law Firm, 3) McCormicks Heating & Air Conditioning, 4) Pieper Plumbing; Yorkshire Playhouse for: 1) Carquest Auto Parts (Slack Auto Supply), 2) Crossroads Awards, 3) GoodyPop, 4) H&R Block, 5) Peterson's Petal Company, 6) Yorkshire Playhouse; United Way for: 1) Brandt Carpet & Tile, LLC, 2) Kinetic by Windstream, 3) Life Unpredictable Photography, 4) Mr. Dukes Mercantile, 5) Penner's Tire & Auto Tire Pros, 6) Rustic Dry Goods; York Community Foundation for: 1) Coldwell Banker - NHS Real Estate, 2) Ginny's Hallmark, 3) Kirtsey's Clothing & Gift Boutique, 4) The Quilt Basket, 5) Svehla Law Offices, 6) The Personal Touch.

Motion to approve all applications for the York Sip & Stroll event to take place on September 29, 2022. Ayes with a motion by Tony North and a second by Jeff Pieper.

Jerry Wilkinson: Absent, Scott Van Esch: Yea, Jennifer Sheppard: Yea, Matt Wagner: Yea, Tony North: Yea, Sheila Hubbard: Yea, Jeff Pieper: Yea, Christi Lones: Yea

Executive Session to discuss Union Contracts

Individuals going into the executive session were the Council, Mayor, City Administrator and Clerk. Motion to go into Executive Session to discuss Union Contracts at 7:11 o'clock p.m. Ayes with a motion by Tony North and a second by Sheila Hubbard.

Jerry Wilkinson: Absent, Scott Van Esch: Yea, Jennifer Sheppard: Yea, Matt Wagner: Yea, Tony North: Yea, Sheila Hubbard: Yea, Jeff Pieper: Yea, Christi Lones: Yea

Adjournment from Executive Session

Motion to adjourn from Executive Session at 7:33 o'clock p.m. where no action was taken. Ayes with a motion by Matt Wagner and a second by Tony North.

Jerry Wilkinson: Absent, Scott Van Esch: Yea, Jennifer Sheppard: Yea, Matt Wagner: Yea, Tony North: Yea, Sheila Hubbard: Yea, Jeff Pieper: Yea, Christi Lones: Yea

Adjournment

There being no further business to come before the Council, the Mayor adjourned the meeting, the time being 7:34 o'clock p.m.

SORTED BY VENDOR

VENDOR	NAME	NO# INVOICES	TOTAL AMOUNT	1099 ACCT NO#	G/L ACCT NO#	G/L NAME	G/L AMOUNT
01-00010	GALE	3	308.14	N			
01-00090	THE HOME DEPOT PRO	2	1,659.26	N			
01-00110	MATHESON TRI-GAS	1	100.39	N			
01-00120	JACKSON SERVICES INC	10	561.07	N			
01-0019	DEREK J PALIK	1	47.28	N			
01-00210	EAKES OFFICE PLUS	2	832.16	N			
01-00290	NORTH PRINTING & OFFICE S	7	494.09	N			
01-00340	BOUND TREE MEDICAL LLC	4	1,431.71	N			
01-00360	CITY OF YORK	2	262.68	N			
01-00400	BEAVER BEARINGCOMPANY	1	25.81	N			
01-00540	GLOBAL TECH, INC.	9	6,985.97	N			
01-00620	ROY NICKELS	1	179.55	N			
01-00640	NEBRASKA PUBLIC POWER DIS	1	41,458.42	N			
01-00710	OVERLAND SAND & GRAVEL	4	4,517.96	N			
01-00750	PIEPERS INC	5	307.02	N			
01-00780	PRESTO X COMPANY	12	530.79	N			
01-00800	BURST, LLC	26	913.94	N			
01-00810	RECREATION SUPPLY CO.	1	820.87	N			
01-00911	CORNERSTONE INS GROUP	1	4,220.00	N			
01-00960	GRAINGER	2	457.86	N			
01-01050	MICROFILM IMAGING SYSTEMS	1	120.00	N			
01-01090	BAKER & TAYLOR, INC	1	84.85	N			
01-01280	PLATTE VALLEY COMMUNICATI	1	329.50	N			
01-01290	GRAND CENTRAL FOODS, INC.	12	564.22	N			
01-01340	KOPCHOS SANITATION, INC	8	1,426.25	N			
01-01470	SERVI-TECH LABORATORIES	2	140.30	N			
01-01510	HACH CO.	1	2,595.40	N			

SORTED BY VENDOR

VENDOR	NAME	NO# INVOICES	TOTAL AMOUNT	1099 ACCT NO#	G/L NAME	G/L AMOUNT
01-01650	UNION BANK	1	637.00	N		
01-0168	BRIT A KOCH	1	98.05	N		
01-01840	CORNERSTONE BANK	1	95.00	N		
01-01940	SARGENT DRILLING	1	1,252.50	N		
01-02080	TYLER TECHNOLOGIES - INCO	1	1,595.00	N		
01-0217	RUSSELL COFFEY	1	675.00	N		
01-02250	MILLER SEED & SUPPLY CO	10	961.12	N		
01-02500	YORK FARM SUPPLYLLC	1	8.70	N		
01-02560	CITYSERVICEVALCON LLC	1	32.44	N		
01-03020	MIKE QUBTY	1	1,293.90	Y		
01-04050	GALLS INCORPORATED	3	401.97	N		
01-04240	NE DEPT OF REVENUE	1	19.01	N		
01-04420	SOUTHEAST NE DEV DIST	2	6,920.00	N		
01-05210	NEBRASKA LIBRARYASSOCIAT	1	75.00	N		
01-05310	SAPP BROTHERS PETROLEUM,	4	5,177.09	N		
01-05600	YORK GENERAL HOSPITAL	1	135.25	N		
01-05870	WEX BANK	1	13,785.95	N		
01-06370	HEIMAN FIRE EQUIPMENT, IN	1	16.14	N		
01-06410	CASH-WA DISTRIBUTING	1	548.33	N		
01-07330	PUSH PEDAL PULL	1	508.27	N		
01-08000	NEVCO SCOREBOARD CO	1	1,289.98	N		
01-08410	BEACON ATHLETICS	1	457.00	N		
01-09090	WINDSTREAM	1	223.79	N		
01-09110	HY-TEC AUTO SERVICE	2	976.51	N		
01-09220	CENTRAL NEBRASKA REFRIGER	1	105.97	N		
01-09870	NEBRASKA NOTARY ASSOCIATI	1	30.00	N		
01-1	MISCELLANEOUS VENDOR	1	79.00	N		

SORTED BY VENDOR

VENDOR	NAME	NO# INVOICES	TOTAL AMOUNT	1099 ACCT NO#	G/L ACCT NO#	G/L NAME	G/L AMOUNT
01-10020	YORK COUNTY REGISTER OF D	1	10.00	N			
01-10110	BADGER METER INC	1	291.80	N			
01-10770	JOHNSON SERVICE CO	1	29,150.00	N			
01-11190	MEAD LUMBER & RENTAL	3	61.71	N			
01-11220	PAUL DAVIS RESTORATION &	1	55.00	N			
01-11670	STEVE HOLMES	1	150.00	Y			
01-12820	JONES & BARTLETT PUBLISHE	1	403.86	N			
01-14410	LINCOLN WINWATERWORKS	2	896.74	N			
01-14470	FARMERS COOPERATIVE	4	169.24	N			
01-14820	CHRIS MULINIX	1	150.00	N			
01-14850	CHEREE FOLTS	2	186.88	N			
01-14880	ALFRED BENESCH & CO	1	768.00	N			
01-15060	Jones Automotive	1	395.00	N			
01-15280	ERICK BREKKE	1	214.42	N			
01-15880	CHARLIE'S U-SAVE RX	1	311.22	N			
01-15900	ARAMARK UNIFORM SERVICE	3	167.76	N			
01-15940	MED-TECH RESOURCE INC	2	703.24	N			
01-15980	HDR ENGINEERING INC	4	59,022.51	N			
01-16290	MICHAELA STUHR	2	607.73	N			
01-16450	GERALD WILKINSON	1	650.00	Y			
01-16710	ONE CALL CONCEPTS INC	1	160.84	N			
01-16900	AQUA-CHEM INC	4	4,194.73	N			
01-18820	DYNAMIC MEDIA	1	419.40	N			
01-19370	NE TECHNOLOGY & TELECOMMU	2	138.04	N			
01-20850	DEARBORN LIFE INSURANCE C	1	4,127.99	N			
01-22050	HEAVY METAL SUPPLY CO	1	10.98	N			
01-22660	SPECTRUM ENTERPRISE	2	560.87	N			

SORTED BY VENDOR

VENDOR	NAME	NO# INVOICES	TOTAL AMOUNT	1099 ACCT NO#	G/L ACCT NO#	G/L NAME	G/L AMOUNT
01-22790	SITE ONE LANDSCAPE SUPPLY	1	116.26	N			
01-23060	ELECTRIC PUMP INC	2	2,922.41	N			
01-24090	AXIA PAYMENTS	1	301.86	N			
01-24100	GLOBAL PAYMENTS	1	817.57	N			
01-24250	JEFFERSON COMMUNITYHEALT	1	10.00	N			
01-24440	QUALITY SOUND & COMMUNICA	1	35.00	Y			
01-25290	SCOTT GONNERMAN	1	9,690.90	N			
01-25530	SAM'S CLUB MC/SYNCB	1	6,595.02	N			
01-25820	MERCHANT SERVICES	1	3,101.44	N			
01-25870	YORK SPRINKLERSYSTEMS	1	142.27	N			
01-26330	QUICK MED CLAIMS	2	2,473.69	N			
01-26480	CONNER PSYCHOLOGICALSERV	1	385.00	N			
01-27210	MIDWEST AUTO PARTS INC.	3	176.93	N			
01-27310	NICK'S FARM STORE	1	23.22	N			
01-27440	LIVE WELL COUNSELING CENT	1	625.00	N			
01-27470	ROWE LAWN SERVICE	1	1,200.00	N			
01-27480	BRIAN ROWE	1	900.00	Y			
01-27490	SUE CRAWFORD	1	19.00	N			
01-27990	HANS JOHNSON	1	435.00	Y			
01-28020	NEC COMMUNICATIONSAMERIC	1	2,183.24	N			
01-28080	FIRST NATIONALCOMPANY	1	1,000.00	N			
01-28510	LEE ENT ADVERTISING	2	5,526.14	N			
01-28520	IRON DIAMOND MEDIA	1	1,300.00	N			
01-28540	AMAZON BUSINESS	10	1,807.11	N			
01-29140	CIVIC PLUS	1	275.00	N			
01-29270	ALLO	1	644.84	N			
01-29280	SAM HEITZ	1	65.63	N			

SORTED BY VENDOR

VENDOR	NAME	NO# INVOICES	TOTAL AMOUNT	1099 ACCT	G/L NO#	G/L NAME	G/L AMOUNT
01-29290	JEFF BROWN	1	133.48		N		
*** REPORT TOTALS ***		255	255,917.12				
		Payroll	155,242.10				
		Total	410,109.08				

SELECTION CRITERIA

VENDOR SET: 01 CITY OF YORK
VENDOR: ALL
BANK: ALL
VENDOR CLASS(ES): ALL CLASSES

TRANSACTION SELECTION

REPORTING: PAID ITEMS

	=====PAYMENT DATES=====	=====ITEM DATES=====	=====POSTING DATES=====
PAID ITEMS DATES	: 8/05/2022 THRU 8/18/2022	0/00/0000 THRU 99/99/9999	0/00/0000 THRU 99/99/9999

PRINT OPTIONS

REPORT SEQUENCE: VENDOR #
G/L EXPENSE DISTRIBUTION: NO
CHECK RANGE: 000000 THRU 999999

**CITY OF YORK
CASH BALANCES
for the Month of July 2022**

Fund #	Fund	10/1/2021 Balance	Current Month Receipts	YTD Receipts	Current Month Disbursements	YTD Disbursements	Ending Balance
10-101	General	\$4,778,747.46	\$645,666.14	\$7,338,664.32	\$741,317.58	\$7,719,696.12	\$4,397,715.66
	American Rescue Plan Act	\$694,322.93	\$0.00	\$0.00	\$516.72	\$124,660.00	\$569,662.93
10-102	Auditorium	\$0.00	\$12,431.33	\$117,909.35	\$9,403.71	\$102,453.85	\$15,455.50
10-103	Park	\$0.00	\$46,681.39	\$468,870.91	\$40,612.82	\$348,717.62	\$120,153.29
10-104	Police	\$0.00	\$192,626.99	\$1,890,207.56	\$167,403.46	\$1,715,170.06	\$175,037.50
10-105	Community Center	\$0.00	\$40,569.58	\$475,174.04	\$41,121.97	\$390,946.06	\$84,227.98
10-106	Aquatic Center	\$0.00	\$43,389.35	\$264,700.83	\$79,202.91	\$225,847.59	\$38,853.24
10-110	Senior Center	\$0.00	\$1,478.42	\$14,784.20	\$1,733.10	\$18,083.52	(\$3,299.32)
10-201	Convention Center	\$0.00	\$48,652.01	\$556,473.84	\$30,740.99	\$367,518.18	\$188,955.66
10-111	Ball Field	\$0.00	\$39,539.91	\$301,275.44	\$56,209.64	\$346,649.87	(\$45,374.43)
13	User Fees	\$16,710.00	\$0.00	\$3,735.00	\$485.11	\$639.38	\$19,805.62
22	Ambulance	\$42,650.00	\$122,272.30	\$1,555,420.01	\$141,804.15	\$1,307,439.41	\$290,630.60
22	Fire	\$0.00	\$75,027.33	\$454,880.82	\$30,027.42	\$354,850.11	\$100,030.71
24	Library	\$0.00	\$40,768.78	\$512,799.01	\$37,882.72	\$474,171.66	\$38,627.35
14-144	General Capital-Auditorium	\$41,077.26	\$39,413.95	\$39,413.95	\$80,700.00	\$80,491.21	\$0.00
14-145	General Capital-Comm Ctr	\$733,083.89	\$84,915.89	\$84,915.89	(\$91,861.60)	\$817,999.78	\$0.00
General Balances		\$6,306,591.54	\$1,433,433.37	\$14,079,225.17	\$1,367,300.70	\$14,395,334.42	\$5,990,482.29
11	Keno	\$43,533.67	\$10.57	\$1,566.74	\$3,405.16	\$13,650.72	\$31,449.69
20	Aviation	\$499,417.67	\$30,923.91	\$329,326.05	\$81,591.42	\$332,097.45	\$496,646.27
20	Aviation - Federal Funds	\$0.00	\$0.00	\$0.00	\$0.00	\$0.00	\$0.00
31	Fire Pension	\$168,573.07	\$16,761.49	\$167,332.91	\$12,204.52	\$130,136.65	\$205,769.33
30	Police Pension	\$160,080.26	\$6,118.89	\$60,991.06	\$5,831.22	\$60,955.97	\$160,115.35
32	911 Surcharge	\$61,036.46	\$22.59	\$7,115.73	\$0.00	\$0.00	\$68,152.19
33	Health Insurance	\$1,493,990.17	\$126,811.89	\$1,210,525.95	\$108,714.03	\$1,333,214.99	\$1,371,301.13
Total Tax Funds		\$8,733,222.84	\$1,614,082.71	\$15,856,083.61	\$1,579,047.05	\$16,265,390.20	\$8,323,916.25
50	Street	\$1,649,799.98	\$230,221.59	\$2,173,744.78	\$299,666.42	\$1,402,929.07	\$2,420,615.69
70	Landfill-Cash & Invest	\$2,074,322.58	\$166,688.53	\$5,655,463.55	\$80,274.12	\$1,943,593.00	\$5,786,193.13
	Landfill-Operations	\$112,807.75	\$53,196.75	\$1,781,116.78	\$53,196.75	\$1,781,116.78	\$112,807.75
	Landfill-Debt Service	\$0.00	\$27,077.37	\$162,464.22	\$0.00	\$29,195.88	\$133,268.34
78	Old Landfill Closure	\$12,051.70	\$0.00	\$35.62	\$0.00	\$0.00	\$12,087.32
79	Landfill Post Closure	\$2,455,332.72	\$0.00	\$88,513.62	\$0.00	\$0.00	\$2,543,846.34
	C&D Site Closure/Post Clo	\$173,091.82	\$0.00	\$17,558.26	\$0.00	\$0.00	\$190,650.08
75	Landfill Construction	(\$110,579.28)	\$0.00	\$0.00	\$0.00	\$1,470,316.27	(\$1,580,895.55)
Total Non-Tax Funds		\$ 6,366,827.27	\$ 477,184.24	\$ 9,878,896.83	\$ 433,137.29	\$ 6,627,151.00	\$ 9,618,573.10
12	CDBG Revolving Loan	\$78,659.75	\$4,182.09	\$294,136.51	\$0.00	\$252,340.11	\$120,456.15
12	Housing Grant - Federal Fun	(\$58,367.05)	\$617.76	\$46,895.88	\$0.00	\$11,141.21	(\$22,612.38)
12	Buy Rehab Sell	\$173,600.68	\$9.78	\$80,246.35	\$0.00	\$89,349.45	\$164,497.58
60	Federal Proj (Blackburn Br)	\$938,178.43	\$1,874.07	\$547,409.61	\$521.08	\$9,299.80	\$1,476,288.24
60	Shadow Brook Project	(\$14,374.68)	\$0.00	\$0.00	\$0.00	\$0.00	(\$14,374.68)
60	Concrete Panel/Asphaltry Pro	\$0.00	\$0.00	\$5,150,000.00	\$0.00	\$876,666.71	\$4,273,333.29
19-192	Land Acq - Indust. Park	\$1,121,843.69	\$523.35	\$453,605.15	\$2,000.00	\$80,925.98	\$1,494,522.86
19-193	Land Acq - Right-of-ways	\$21,140.13	\$0.00	\$0.00	\$0.00	\$0.00	\$21,140.13
19-194	Land Acq - Parks	\$66,046.21	\$0.00	\$0.00	\$0.00	\$0.00	\$66,046.21
19-194	Council of Gov'ts CD's	\$32,976.14	\$0.00	\$0.00	\$25,568.22	\$32,976.14	\$0.00
16	Total Bond Funds	\$353,368.01	\$54,599.94	\$548,353.46	\$0.00	\$685,332.78	\$216,388.69
40	Total TIF Funds	\$475,757.01	\$132.61	\$87,441.50	\$0.00	\$165,399.50	\$397,799.01
Total Misc. Funds		\$ 3,188,828.32	\$ 61,939.60	\$ 7,208,088.46	\$ 28,089.30	\$ 2,203,431.68	\$ 8,193,485.10
Total All Funds		\$ 18,288,878.43	\$ 2,153,206.55	\$ 32,943,068.90	\$ 2,040,273.64	\$ 25,095,972.88	\$ 26,135,974.45

LB 357 Cash Available	(from Page 2)	\$1,975,314.71
Wastewater Cash Available	(from Page 3)	\$3,284,000.51
Water Cash Available	(from Page 3)	\$8,000,129.04
		<u>\$ 39,395,418.71</u>

City of York
LB 357 Funds Summary

	30-Jun-22	31-Jul-22
LB 357 Funds Allocation		
Cash Balance	\$15,144,392.81	\$15,280,368.16
Less: Quiet Zone	(\$1,496,028.97)	(\$1,496,028.97)
School-Owned Properties	(\$753,520.34)	(\$810,470.87)
Ball Field	(\$9,564,326.31)	(\$9,564,326.31)
City-Owned Properties	(\$1,421,183.43)	(\$1,434,227.30)
Total Cash Available	\$1,909,333.76	\$1,975,314.71
Less Restricted Funds		
Debt Service	(\$605,550.58)	(\$683,205.39)
Debt Service Reserve	\$0.00	\$0.00
Total Unallocated LB 357 Funds	\$1,303,783.18	\$1,292,109.32

City of York Public Works Summary

	30-Jun-22	31-Jul-22
Wastewater		
Cash Balance	\$3,128,321.19	\$3,284,000.51
Less: Construction Fund	\$0.00	\$0.00
 Total Cash Available	 \$3,128,321.19	 \$3,284,000.51
 Less Restricted Funds		
Operations	\$0.00	\$0.00
Debt Service	(\$145,464.55)	(\$268,628.18)
Debt Service Reserve	\$0.00	\$0.00
Renewal & Replacement	\$0.00	\$0.00
 Total Unrestricted Funds	 <u>\$2,982,856.64</u>	 <u>\$3,015,372.33</u>
 Water		
Cash Balance	\$7,293,587.84	\$7,398,530.64
Less: Construction Fund	(\$282,380.35)	(\$282,380.35)
Add: Farm Management Acct	\$899,701.19	\$883,978.75
 Total Cash Available	 \$7,910,908.68	 \$8,000,129.04
 Less Restricted Funds		
Operations	(\$108,577.00)	(\$108,577.00)
Debt Service	(\$6,378.48)	(\$67,388.26)
Debt Service Reserve	(\$266,768.69)	(\$266,768.69)
 Total Unrestricted Funds	 <u>\$7,529,184.51</u>	 <u>\$7,557,395.09</u>

City of York
for the Month of July 2022

Auditors Grouping	<u>Total Amount</u>	<u>Restricted or Assigned</u>	<u>Unrestricted</u>	<u>Notes</u>
10 General:				
General	\$4,397,715.66	35,128.41	\$4,362,587.25	Restricted - YCF (Parks, Police) and Museum Donations
ARP Act \$	\$569,662.93	\$569,662.93	\$0.00	Restricted grant money
Senior Center	(\$3,299.32)		(\$3,299.32)	
Police	\$175,037.50		\$175,037.50	
Community Center	\$84,227.98		\$84,227.98	
Park	\$120,153.29		\$120,153.29	
Auditorium	\$15,455.50		\$15,455.50	
Convention Center	\$188,955.66		\$188,955.66	
Aquatic Center	\$38,853.24		\$38,853.24	
Ball Park	(\$45,374.43)		(\$45,374.43)	
Total	\$5,541,388.01	\$604,791.34	\$4,936,596.67	
13 User Fees	\$19,805.62	\$19,805.62		Assigned
14 General Capital Projects	\$0.00	\$0.00		
22 Fire/EMS	\$390,661.31	\$43,049.05	\$347,612.26	Restricted - York Community Foundation
24 Library	\$38,627.35		\$38,627.35	
30 Police Pension	\$160,115.35		\$160,115.35	
31 Fire Pension	\$205,769.33		\$205,769.33	
Total General	\$6,356,366.97	\$667,646.01	\$5,688,720.96	
50 Street	\$2,420,615.69	\$2,420,615.69		
20 Aviation	\$496,646.27	\$496,646.27		Assigned
16 Debt Service	\$216,388.69	\$216,388.69		
15 LB 357	\$1,975,314.71	\$1,975,314.71		
60 Capital Projects	\$5,735,246.85	\$5,735,246.85		
12 CDBG	\$262,341.35	\$262,341.35		
11 Keno	\$31,449.69	\$31,449.69		
19 Sinking	\$1,581,709.20	\$0.00	\$1,581,709.20	
32 E911	\$68,152.19	\$68,152.19		
40 TIF	\$397,799.01	\$397,799.01		
Total Governmental	\$19,542,030.62	\$12,271,600.46	\$7,270,430.16	
70 Landfill:				
Landfill	\$5,786,193.13		\$5,786,193.13	
Landfill-Operations	\$112,807.75	\$112,807.75		Bond Requirements
Landfill-Debt Service	\$133,268.34	\$133,268.34		Bond Requirements
Old Landfill Closure	\$12,087.32	\$12,087.32		
Landfill Closure/Post	\$2,543,846.34	\$2,543,846.34		
C&D Site Closure/Post	\$190,650.08	\$190,650.08		
Construction	(\$1,580,895.55)		(\$1,580,895.55)	
Total Landfill	\$7,197,957.41	\$2,992,659.83	\$4,205,297.58	
80 Wastewater	\$3,284,000.51	\$268,628.18	\$3,015,372.33	Bond Requirements
90 Water	\$8,000,129.04	\$442,733.95	\$7,557,395.09	Bond Requirements
Total Enterprise	\$18,482,086.96	\$3,704,021.96	\$14,778,065.00	
33 Health Insurance	\$1,371,301.13	\$1,371,301.13		Assigned for insurance claims needs
Total City	\$39,395,418.71	\$17,346,923.55	\$22,048,495.16	

DEPARTMENT REPORTS

JULY 2022

COMMUNITY CENTER
FIRE
KILGORE MEMORIAL LIBRARY
POLICE
PUBLIC WORKS

Community Center

Total Income (Unofficial): \$6,683.00

	CASH	CHECK	CREDIT	TOTAL	Center Admissions	Aud Admissions	FAC Admissions	Center Programs	FAC Programs	Center Rentals	Aud Rentals	Miscellaneous	Notes
TOTALS	\$2,149.50	\$1,414.00	\$3,119.50	\$6,683.00	\$3,777.00	\$0.00	\$0.00	\$1,246.00	\$0.00	\$230.00	\$1,430.00	\$0.00	

Total Memberships/Day Passes/Coupon Books Sold: 385

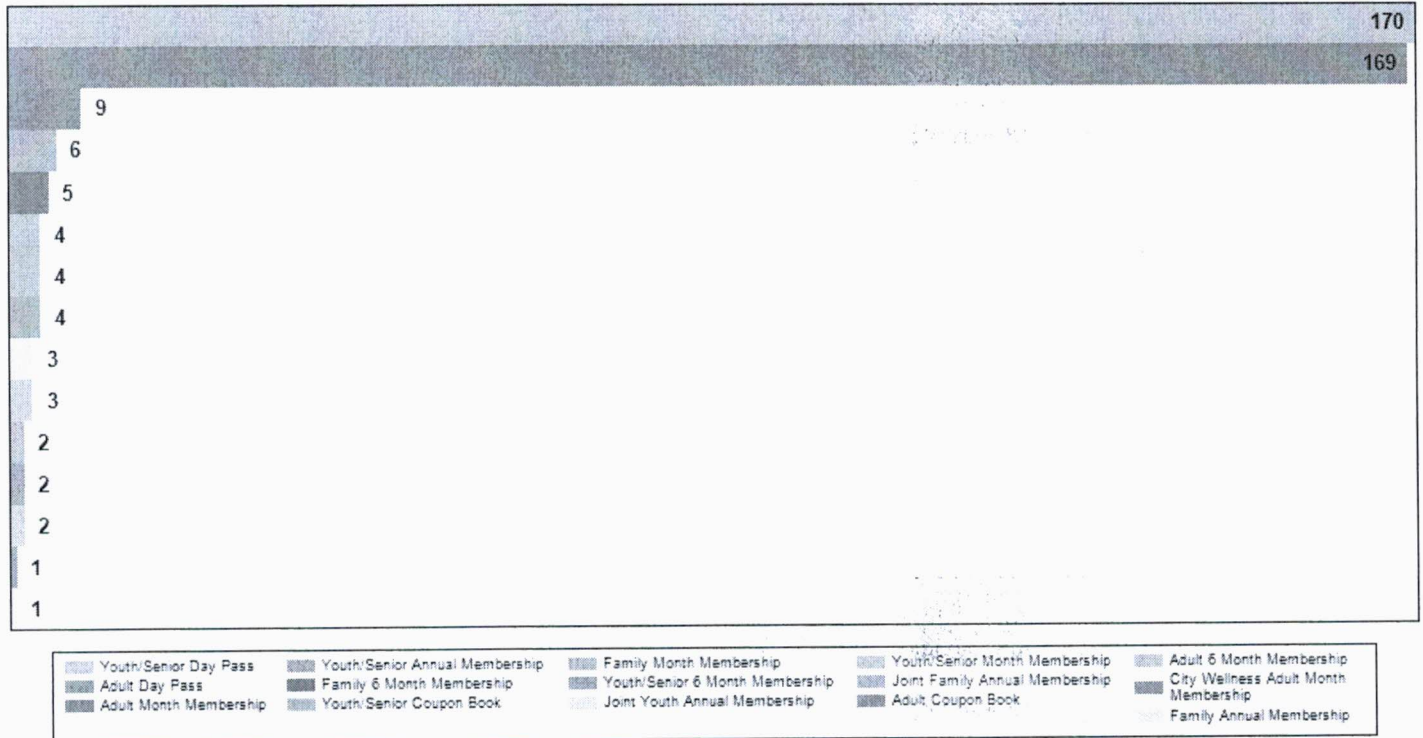

Total Membership Attendance: 2,045

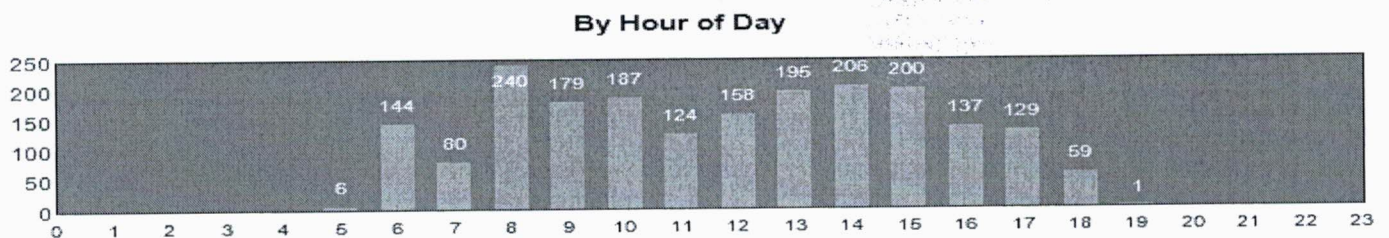
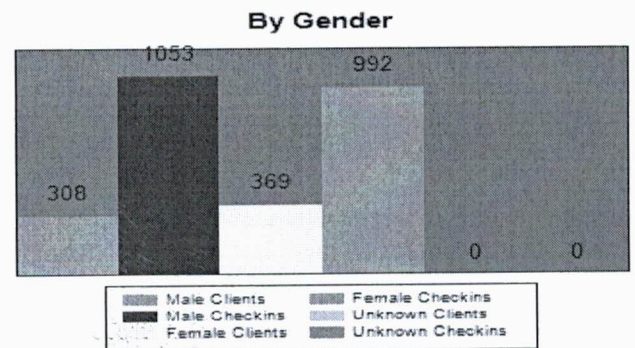
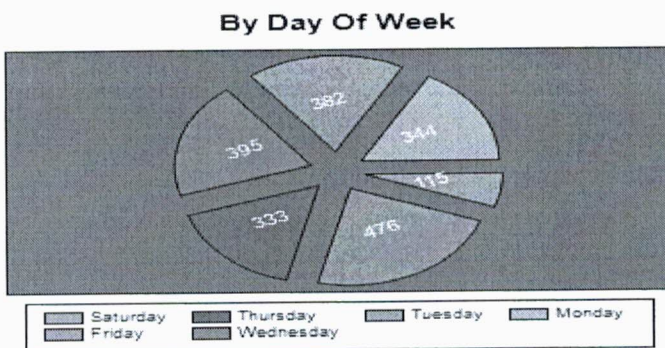

York College: Summer Break

Adult/Community/Youth Programs/Leagues:

The adult programs/leagues in July included Adult Lap Swim, Senior Water Aerobics, FAC Adult Lap Swim, FAC Adult Water Walking, Noon Ball, Pickleball Open Rec, FAC Adult Water Aerobics, Yoga, Coed 6's Sand Volleyball, Cornhole Tournament, and Coed Softball.

The community programs/leagues in July included Story Walk, Trail Trotters, FAC Floaty Fridays, Beach Party, Dive-In Movie, Transportation Exploration, City-Wide Water Fight, Family Fun Day, Soaring High, and Art in the Park.

The youth programs/leagues in July included Swimming Lessons, Float 4 Life, FAC Toddler Time, Youth Summer Camp, Sandbox Saturdays, Hometown Heroes, Baking the 4-H Way, GG Leagues – Online Gaming Competition, Parents Night Out, Little Movers and Shakers, Artistic Me!, and *NEW* Junior Lifeguarding.

There were 98 Community Center rentals/reservations in July for YPR programs/leagues (Adult Lap Swim, Senior Water Aerobics, Hometown Heroes, Yoga, Little Movers and Shakers, Junior Lifeguarding, and Artistic Me!), party packages (birthday parties), Turf Committee meetings, a YCDC meeting, and a Nebraska Prime Fastpitch parents meeting.

Auditorium

The Auditorium is closed for Open Rec until October. There were 47 Auditorium rentals/reservations in July for YPR programs/leagues (Noon Ball, Pickleball Open Rec, Youth Summer Camp, and a Cornhole Tournament), a craft show, and a family reunion.

Parks

There were 10 East Hill Park rentals/reservations in July for YPR programs/leagues (Sandbox Saturdays, Youth Summer Camp, Coed Sand Volleyball, and Art in the Park) and YHS volleyball.

There were 7 Harrison Park rentals/reservations in July for a York Adopt-A-Pet Annual Family Glo Walk Fur Luv and YPR programs/leagues (Coed Sand Volleyball and Youth Summer Camp).

There was 1 Mincks Park rental/reservation in July for a YPR program (Soaring High).

Family Aquatic Center

There were 110 FAC rentals/reservations in July for York Dolphins swim team practices and a meet, YPR programs (Session 2 and 3 Swimming Lessons, Float 4 Life, Adult Lap Swim/Adult Water Walking/Toddler Time, Youth Summer Camp, Adult Water Aerobics, Parents Night Out, Beach Party, Dive-In Movie, Family Fun Day, and Junior Lifeguarding), splash parties (a birthday party and a Boost party), after hours rentals (a pool party, a York Dolphins swim team party, a YHS football party, a York Fusion softball party, and an Arbor Drive Community Church party).

Total Admissions Income (Unofficial): \$12,366.27

	CASH	CHECK	CREDIT	FAC TOTAL	FAC Admissions	FAC Programs	Swim Team Fees	FAC Attendance
TOTALS	\$6,743.27	\$1,741.00	\$3,882.00	\$12,366.27	\$12,191.27	\$175.00	\$0.00	6332

Total Concessions Income (Unofficial): \$11,697.80

CASH	CHECK	CREDIT	FAC Concessions TOTAL
\$9,302.05	\$218.00	\$2,177.75	\$11,697.80

Ballpark Complex

There were 5 Levitt Stadium field rentals/reservations in July for York Cornerstone Kings American Legion Juniors baseball game, Seniors baseball games, and an Area B4 Senior tournament.

There were 18 Miller Park field rentals/reservations in July for Fusion softball practices, Knights baseball practices and a game, Nebraska Prime Fastpitch softball tryouts, and a YPR league (Coed Softball).

There were 25 Ballpark Complex batting cage rentals/reservations in July for Fusion softball practices and Knights baseball practices.

There were 57 Ballpark Complex field rentals/reservations in July for Knights baseball practices, YHS softball practices, Fusion softball practices, a game, a tournament, and tryouts, a Nebraska Prime Fastpitch softball practice, Cornhusker State Games baseball, and softball tryouts.

Total Income (Unofficial): \$19,924.93

	CASH	CHECK	CREDIT	TOTAL	Complex Concessions	Miller Concessions	Rental Fees	Player Fees	Sponsorships	RV Fees	Split % w/	Notes
TOTALS	\$13,559.20	\$4,145.00	\$2,220.73	\$19,924.93	\$15,954.93	\$0.00	\$1,450.00	\$0.00	\$2,200.00	\$320.00	\$0.00	

SupplyWorks

Auditorium	\$37.08
Library	\$115.12
City Office	\$62.87
Police Dept	\$32.00
WWTP	\$97.59
Garage	\$37.08
Fire Dept	\$265.99
Ballfield	\$381.44
Parks	\$297.98
FAC	\$32.00
Palmer Museum	\$88.35
Total	\$1447.50

Report Completed by Cheree Folts, Director of Parks and Recreation on 8/12/22.

York Fire Department

Monthly report for July 2022

July of 2022 was a very busy month for York Fire Department. We had 150 calls for the month. This is the 2nd time this year we have had 150 calls in a month. 117 of these calls were 911 EMS. On top of that we had 21 transfers to facilities with a higher level of care. I would like to take some time and commend our staff for the response to the ceiling collapse at the Hampton Inn on July 3rd at 2100. While most of us were waiting for the fireworks to start up at the fairgrounds. We were paged out. I really did not expect a good showing of our personnel because of the time of night and it being the night before the 4th. We had hired back to 4 with one of our volunteers anticipating a busy night with a lack of personnel. Our ambulance went in route immediately with 3. I went in route from a friend's house right after. Then our heavy rescue truck went in service after filling with volunteers. We had another ambulance call come in about this time. Our guys immediately sized up the situation and we went to work. YPD and YSO secured the scene and evacuated the motel. Using a Hitz's Towing truck and the heavy lifting expertise of Randy and Ross Hitz and Jeff Mogul we determined the safest way to stabilize the ceiling and make it safe for our personnel to use our rescue struts and airbags to get the victim out. The teamwork displayed at this incident was outstanding, whether it was law enforcement, towing, fire marshal, or rescue we worked together and got it done. The debriefing after was much needed and probably the best one that I have attended. Now it is up to the lawyers to work it out.

Fire calls for the month amounted to 11 calls. 4 of these calls were automatic fire alarms with no issues found. We had a vehicle fire with a loss of approximately \$500. We had to cool off a load of bees in route to Texas. And some small grass fires and rubbish fires. We have shut down all burn permits until we get some much-needed rain.

We did standby for the fireworks July 3rd. The Fire Chief attended the 911 Comms Committee meeting on the 8th and the York County Mutual Aid meeting on the 20th. Our big event was the Transportation Exploration on July 16th. We had our aerial 640 there and gave the kids tours and then 640 went to the water fight.

We accomplished a lot of training for the month of July. Captain Quick and the Fire Chief attended and completed a Fire Officer 2 class that was given at Norfolk Fire Department. We started a training academy for our new people. This class will give them the skills to step up and help us out at our calls, both EMS and fire. It is being taught by both our career staff and volunteers. Our EMS training for EMT's was OB. We had a house burn on the 23rd where a lot of interior firefighting skills were taught. Reggie continued his paramedic studies. Career staff traveled to Corteva Production to learn high rise and stand pipe procedures. We had a total of 284 hours of training for the month.

It is taking some time but I believe we are going through a culture change here at York Fire Department. Our newer people are giving us a breath of fresh air and our staff is realizing the stuff we can accomplish with training and teamwork. Our future training plans include a Firefighter 1 class that we are going to teach using York Fire personnel as the instructors. This is a first. Our personnel are taking ownership.

Kilgore Memorial Library
Director's Report
Prepared for the August, 2022
York City Council meeting

1. The Baker Display Case and Bedient Gallery are empty right now. If anyone has a collection or information to display let the library staff know. We would enjoy adding you to our calendar.
2. Summer reading for all ages has ended. Plans are being developed for fall programming to begin in August with the YHS Success Class visits and Story Time in September.
3. The popular SMACKDOWN with Seward to learn, "Who Reads More on Highway 34!" Ended in defeat for York. The final tally was York 1,885 and Seward 1,950.
4. The York Chamber of Commerce Ambassadors Club will be visiting Kilgore Library on Thursday, August 18 at 3:30 pm to celebrate the partnership we enjoy with the York Public Schools Sixpence Program through our Early Childhood Discovery Center and outdoor Music Garden. This celebration will also include recognition for the donors who have made donations to support the library with items for these centers.
5. The Altered Book Club will meet on August 22. The activity planned is to make greeting cards from book pages.
6. The Saturday morning Lego Club continues to meet through the summer. Stop in any Saturday at 10 am to learn more.
7. Our IT infrastructure continues to improve with support of level two funding from the e-rate program we participate in each year. Our new Firewall equipment was successfully installed by library staff member, Tyler Nelsen in on August 3.
8. Rachel Mayfield has completed the first continuing education course through the Library Juice Academy. This training was funded by a grant from the Nebraska Library Commission.

Respectfully submitted by,



Debora Robertson
Director, Kilgore Memorial Library

LIBRARY DATA AT A GLANCE

Data Type	Oct 2021	Nov 2021	Dec 2021	Jan 2022	Feb 2022	March 2022	April 2022	May 2022	June 2022	July 2022	Aug 2022	Sept 2022	Year to Date
Added to Physical Collections	358	260	368	75	445	288	319	281	319	326			3039
Added to E-Book Collections	873	474	491	430	420	673	672	395	592	461			5481
Physical item circulation	5,088	4,994	4,679	4,863	4,820	5,103	4,862	5,543	6,513	6,142			52607
E-books Circulations	1,322	1,384	1,349	1,543	1,262	1,402	1,359	1,475	1,513	1,664			14273
New Patrons	28	27	26	23	25	44	32	32	64	46			347
Public Computer logins	531	508	391	582	534	620	479	485	665	827			5622
Door Count	3,085	2,652	3,379	2,595	2,954	2,771	2,716	3,065	3,698	3,070			29985
Website visits	2,073	4,204	9,734	3908	1,877	2,212	1,713	1,784	1,699	2,118			31322
Meeting Room Use	510	453	372	280	333	436	578	250	610	522			4344

Data Type	Total 2021	Total 2020	Total 2019
Physical Collections	64,107	63,321	63,921
E-Book Collections	52,789	57,200	52,276
Physical item circulation	58,648	45,885	64,409
E-book Circulations	17,647	16,935	12,790
Registered Borrowers	5,104	5,348	8,276
Public Computer logins	6,445	6,391	13,864
Door Count	48,055	36,276	52,003
Website visits	49,025	51,633	59,600
Meeting Room Use	3,000	3,576	5,331

Data for annual report to Nebraska Library Commission submitted 2-10-2022.

POLICE DEPARTMENT MONTH END REPORT

July 2022

CFS = CALLS FOR SERVICE

Accidents calls in total	20
Cases	10
CFS only	10
Property damage accidents	12
Hit & run accidents	5
Personal injury accidents (persons injured – 2)	3
Fatality accidents	0
Number of vehicles involved in accidents	40
Total Mileage patrolled	10,408
(800- 287; 802 –466 ; 803 –209 ; (804 –out of service)	
805 -2279; 806 – 1074; 808 – 4293; (809—out of service)	
Total Calls for Service (CFS)	710
Tickets Issued—(T-traffic/ P-parking/ A-animal/ H-Notification-health)	
T-Citations – 14 ; P-Citations – ;	
T-Warnings – 4 ; P-Warnings -9; A-Warnings – 15; H-Warnings -5;	
P-Non-moving Violation-- 7; Defects—7 ; H-Notifications -- 0;	
Verbal Warnings (all) -- 120 ;	
Health/Vegetation CFS	36
Animal CFS-33 (dog bite- 1).	34
Parking related CFS	32
Extra/Special Services-(Escorts ; Other chks ; Aid ; Patrol)	19
School checks	1
Welfare Checks	32
Alarms (Business/Residential)	13
Traffic related CFS (Stops-159, Offenses-20, Mot. Asst-7).	186
Juvenile involved CFS (juv-runaway/missing/kidnapping-abduction).	14
HHS /Child Abuse/Neglect- Adult Protective Services	22
Assaults/Sexual Assaults reports/investigated	6
Disturbance/Disorderly Conduct CFS	36
Vandalism (Criminal Mischief) reported/investigated.	7
Forgery/Fraud reported/investigated	7
Burglary reported/investigated	2
Larceny (Theft-Motor Veh) reported/investigated	9
Criminal Offenses (Cases Made)	56
-Citations in lieu of Arrest.	5
-Arrests	20



**DEPARTMENT OF PUBLIC WORKS
MONTHLY REPORT**

July — 2022

STREET DEPARTMENT

During the month of July, the central garage serviced and repaired equipment for all city departments as follows:

Street	1	Airport		Park	16	Fire	
Police		Landfill		Wastewater	16	Water	

The street sweeper operated 135 hours in July, during which time 409 miles were swept and 104 cubic yards of material were removed from the city streets.

Other major labor activities included:

Job	Hours
General maintenance	45
Right-of-way maintenance	192
Gravel street/alley maintenance	23
Snow removal	0
Mowing/weed control	83
Tree/shrub maintenance	0
Paved surface maintenance	463
Equipment services	12
Sidewalk repair	0
Traffic signing/signal installation/repair	81
Shop cleaning	40
Storm sewer repair	14
Property Maintenance	19
Trash removal	0
Lane & curb paint	80
Parking lot maintenance	98
Ballfield maintenance	5
TOTAL	1155

PARK DEPARTMENT

Park personnel performed the following activities:

Job	Hours
Trash removal	58
Restroom cleaning	75
Property maintenance	96
Mowing/weed control	405
Tree/shrub maintenance	119
Building maintenance	7
Ball field maintenance	90
Playground equipment maintenance	30
General maintenance	21
Sidewalk repair	8
Paved surface maintenance	15
Equipment services	8
TOTAL	932

WASTEWATER TREATMENT PLANT

Plant operation for July and the comparison figures for July of last year:

	Last Month	2022	2021	Units
Total flow	34,329,024	29,688,322	30,631,928	gallons
Average flow/day	1,144,301	957,688	988,126	gallons
Average flow/person	143	120	123	gallons
Grit and screenings to landfill	72.8	40.54	72.65	tons
Bio solids wasted	1.232436	1.134795	0.882928	MG

Wastewater Treatment Plant personnel performed the following activities:

Job	Hours
Plant wages	207
Laboratory testing	52
Sludge removal	7
Equipment maintenance	165
Building maintenance	48
Sewer system maintenance	47
Property maintenance	58
One-call locates	10
Mow and weed control	23
Pump and well maintenance	11
TOTAL	628

WATER DEPARTMENT

Plant operation figures for July and the comparison figures for July of last year follow:

	Last Month	2022	2021	Unit
Total water pumped	47,405,000	59,154,000	62,281,000	gallons
Total water billed	38,149,980	29,895,570	31,270,388	gallons
Average use per day	1,529,194	1,908,194	2,009,065	gallons
Average use per person	191	239	251	gallons
Total electricity used	68,763	90,746	99,259	kW
Pumps yield	689	652	627	gallons/kW
Peak pumping date	30 th	31 st	29 th	
Peak amount	2,766,000	2,902,000	2,730,000	gallons

Report of office operations for July and comparison figures for July of last year:

	2022	2021
Water bills	1761	1,739
Sewer bills	1673	1,659
New taps	¾"- 0, 1"- 2	0
Service leaks	0	0
Main leaks	0	0
Diggers Hotline calls	183	143

Water Department personnel performed the following activities:

Job	Hours
Plant wages (monitoring wells, etc.)	28
Meter reading	22
Meter maintenance	0
Pump/well maintenance	0
Final notice collection	0
Distribution maintenance	185
One-call locates	10
Property Maintenance	19
Mow and weed control	26
Tower maintenance	4
TOTAL	294

SOLID WASTE RECEIVING CENTER AND LANDFILL

Solid Waste Receiving Center operation figures for July as reported by scale:

	2022		2021	
	Trips	Tons	Trips	Tons
Landfill	873	2469.67	787	2668.30
C & D	429	1277.47	184	593.21
Transfer Station	112	25.05	180	35.74
Brush Pile	156	63.19	257	82.46
Tire Pile	10	0.00	17	0.00
Metal Roll-off	11	0.00	14	0.00
Total	1591	3835.38	1439	3379.71

Revenue collected during July totaled \$165,234.20. The same period last year totaled \$150,725.85.

Landfill personnel performed the following activities:

Job	Hours
Scale/Transfer Station Operation	189
Landfill Equipment	604
Wind screen & litter control	0
Recycling Act	0
TOTAL	793

AIRPORT

Public Works personnel performed the following activities:

Job	Hours
Airport Attendant	122
Building maintenance	0
Mowing/weed control	0
TOTAL	122

CONVENTION CENTER

Public Works personnel performed the following activities:

Job	Hours
Property maintenance	0
Building maintenance	0
Mowing/weed control	0
General maintenance	18
TOTAL	18

SUMMARY BY DEPARTMENT

Department	Hours	Percentage	Full Time Equivalent
Street	1155	29	7.2
Parks/FAC	932	24	5.8
Landfill	793	20	5.0
Wastewater	628	16	3.9
Water	294	7.5	1.8
Airport	122	3	0.76
Convention Center	18	0.5	0.11
TOTAL	3942	100	24.57

BUILDING INSPECTIONS AND PERMITS

Our building inspection activity for July and comparison figures for July of last year are as follows:

Inspections:	2022	2021	Permits Issued:	2022	2021
Building	76	9	Building	202	32
Electrical	42	6	Electrical	9	11
Plumbing	38	3	Plumbing	4	4
Mechanical	29	12	Mechanical	13	29
Nuisance	0	0	Curb/Street	2	1
Total	185	30*	Total	230	77

* Total represents only three weeks in July 2021.

202 permits were issued in July for a value of \$6,049,890.32, which brings the total for the year to \$22,487,526.30. (See attached.)

Permits of note issued:

- Viaero Wireless Replace existing telecom equipment \$730,582.00
- Ben & Tracey Babcock New Single Family Dwelling \$423,890.13
- Walmart Re-roof & fix hail damage \$611,000.00
- Creekside Apartments Re-roof \$210,000.00
- City of York Playground \$1,200,000.00

BOARD OF PUBLIC WORKS

The Board of Public Works met on July 19, 2022. Minutes of the meeting are attached.

Board of Public Works
July 19, 2022 4:00 PM
City Administrator's Office

Attendance taken at 4:00 P.M.

Present Board Members:

Matt Leif
Kenny Ekeler
Bill Williamsen
Marlowe Wall

Absent:

Also Present:

James Paul, Director of Public Works

1. Agenda

2. Roll Call

3. Review Minutes of Last Meeting

Motion Passed: Minutes of the May meeting passed with a motion by Marlowe Wall and a second by Kenny Ekeler.

Marlowe Wall	Yes
Matt Leif	Yes
Bill Williamsen	Yes
Kenny Ekeler	Yes

4. Farm Management Report

Motion Passed: The May Farm Management Report passed with a motion by Bill Williamsen and a second by Kenny Ekeler.

Marlowe Wall	Yes
Matt Leif	Yes
Bill Williamsen	Yes
Kenny Ekeler	Yes

Motion Passed: The June Farm Management Report passed with a motion by Marlowe Wall and a second by Bill Williamsen.

Marlowe Wall	Yes
Matt Leif	Yes
Bill Williamsen	Yes
Kenny Ekeler	Yes

5. Wastewater Financial Reports

Motion Passed: The May Wastewater Financial Reports passed with a motion by Kenny Ekeler and a second by Bill Williamsen.

Marlowe Wall	Yes
Matt Leif	Yes
Bill Williamsen	Yes
Kenny Ekeler	Yes

Motion Passed: The June Wastewater Financial Reports passed with a motion by Bill Williamsen and a second by Kenny Ekeler.

Marlowe Wall	Yes
Matt Leif	Yes
Bill Williamsen	Yes
Kenny Ekeler	Yes

6. Water Financial Reports

Motion Passed: The May Water Financial Reports passed with a motion by Matt Leif and a second by Marlowe Wall.

Marlowe Wall	Yes
Matt Leif	Yes
Bill Williamsen	Yes
Kenny Ekeler	Yes

Motion Passed: The June Water Financial Reports passed with a motion by Bill Williamsen and a second by Kenny Ekeler.

Marlowe Wall	Yes
Matt Leif	Yes
Bill Williamsen	Yes
Kenny Ekeler	Yes

7. Wastewater Claims

Motion Passed: The May Water Claims passed with a motion by Kenny Ekeler and a second by Bill Williamsen.

Marlowe Wall	Yes
Matt Leif	Yes
Bill Williamsen	Yes
Kenny Ekeler	Yes

Motion Passed: The June Water Claims passed with a motion by Bill Williamsen and a second by Kenny Ekeler.

Marlowe Wall	Yes
Matt Leif	Yes
Bill Williamsen	Yes
Kenny Ekeler	Yes

8. Water Claims

Motion Passed: The May Water Claims passed with a motion by Kenny Ekeler and a second by Marlowe Wall.

Marlowe Wall	Yes
Matt Leif	Yes
Bill Williamsen	Yes
Kenny Ekeler	Yes

Motion Passed: The June Water Claims passed with a motion by Bill Williamsen and a second by Matt Ekeler.

Marlowe Wall	Yes
Matt Leif	Yes
Bill Williamsen	Yes
Kenny Ekeler	Yes

9. Director of Public Works Report

Motion Passed: The May Director of Public Works Report passed with a motion by Bill Williamsen and a second by Kenny Ekeler.

Marlowe Wall	Yes
Matt Leif	Yes
Bill Williamsen	Yes
Kenny Ekeler	Yes

Motion Passed: The June Director of Public Works Report passed with a motion by Matt Leif and a second by Kenny Ekeler.

Marlowe Wall	Yes
Matt Leif	Yes
Bill Williamsen	Yes
Kenny Ekeler	Yes

Meeting Adjourned at 4:20 P.M.

James Paul

Building Permits issued in July 2022

01-Aug-22

	OWNER	ADDRESS	LEGAL DESCRIPTION	DESCRIPTION	AMOUNT
98431	Lisa Lynch	1220 N Pennsylvania		Re-roof	6,800.00
98465	Michael Haynes	1218 N Indiana Ave		Re-roof, siding repairs	17,765.00
98466	Kent Reed	1526 E 4th St		Re-roof	15,835.00
98467	Doris Chittenden	120 S Florida		Re-roof, siding repairs	13,970.00
98469	Gina Brahmsteadt	1818 N York Ave		Privacy fence	1,800.00
98470	Mary Ann Karabel	1001 E 3rd St		Re-roof & gutters	11,300.00
98471	Jobob Moore	503 E 12th St		Re-roof	6,123.00
98472	Roger Pracheil	929 S Country Club Ave		Re-roof	14,378.00
98428	Angela Spencer	1436 N Maine Ave		Re-roof	7,000.00
98438	Sullivan Family Dentistry	622 N Burlington		Re-roof	9,500.00
98443	Mountain Tower & Land LLC /	3618 N Division Ave	Tract 25 in the NW 1/4 Section 30, Township 11 N R	Replace existing telecom equipmentmen	730,582.00
98461	Karen Jones	557 W 7th St		Re-roof	13,000.00
98474	Jon Clemens	304 E 17th St		Re-roof, re-side, window replaceme	8,000.00
98475	Martin Barrett	1406 Kennedy Dr		Re-roof, re-side, gutters	28,700.00
98476	Alfredo Barragan	329 N College Ave		Re-roof, gutters	11,500.00
98477	Jeffrey Dunsmoor	604 E 6th St		Re-roof, re-side, gutters	25,900.00
98478	Rick Eldred	118 Beech Ave		Re-roof	1,400.00
98479	Levi Prusia	1025 N York Ave		Shed & concrete addition	5,500.00
98480	Doug Rood	1605 Kennedy Dr		Re-roof, gutters, siding	52,000.00
98481	Corey Koelzer	1214 McKaig Ave		Re-roof	9,300.00
98482	Gregory Schrader	330 N Blackburn Ave		Re-roof	9,700.00
98483	Laurie Plock	1318 N Blackburn Ave		Re-roof	7,740.00

	OWNER	ADDRESS	LEGAL DESCRIPTION	DESCRIPTION	AMOUNT
98464	Nebraska Medical Mart	315 S Lincoln Ave		Sign	700.00
98462	Leland Ward	1702 York Ave		Re-roof, re-side	47,504.33
98445	Bruce Hornbacher	824 W 11th St		Re-roof	18,700.00
98446	Brenda Hines	1101 E 14th St		Re-roof	8,600.00
98451	Terry Harlow	208 Cedar Trail		Re-roof	11,000.00
98447	York University	1215 E 10th St		Sign	2,500.00
98448	York University	800 Kiplinger Ave		Sign	2,500.00
98449	York University	914 Blackburn Ave		Sign	2,500.00
98450	York University	814 Mayhew Ave		Sign	2,500.00
98452	Mark Briggs	721 N Iowa Ave		Re-roof	5,600.00
98452	Will Richard	518 Thompson Ave		Re-roof	6,800.00
98454	Kevin Morrell	1000 N Burlington Ave		Re-roof	6,200.00
98455	Mathew Staehr	940 E 5th Ave		Re-roof	7,100.00
98456	Ernie Stern	1027 N Platte Ave		Re-roof	8,100.00
98457	Jerad Sorgenfrei	605 E 9th St		Re-roof	10,400.00
98458	Jerad Sorgenfrei	615 E 9th St		Re-roof	10,200.00
98459	Katie Harwick	671 E 10th St		Re-roof	5,800.00
98441	Betty Kaslon	404 Maine Ave		Re-roof & gutters	18,366.87
98442	Scott DeRiese	804 E 2nd St		Re-roof & window screens	20,073.18
98444	Debbie Duppert	109 Burlington Ave		Pergola / Gazebo	500.00
98433	Mike Etherton	1202 MacKaig		Re-roof	9,500.00
98437	Gary Romans	1321 Wisconsin Ave		Re-roof	9,153.77
98436	Benjamin Erneigh	2 S Eastridge Dr		Re-roof	15,108.52
98435	Clinton Philson	2218 E 16th St		Re-roof, re-side, replace overhead d	33,500.00

	OWNER	ADDRESS	LEGAL DESCRIPTION	DESCRIPTION	AMOUNT
98425	Ernie Stern	130 N Nebraska Ave		Re-roof	8,100.00
98424	Clifford Swanson	715 N Florida Ave		Re-roof	7,400.00
98429	Jason Heitz	1611 Conner Ave		Re-roof	13,300.00
98427	Glen Roth	28 Arbor Hts		Re-roof	12,500.00
98426	Jordan Talley	805 S Hutchins Ave		Re-roof	8,400.00
98484	Gary Looper	5 Eastridge Dr N		Re-roof	11,350.00
98485	Tim Galvin	7 Arbor Ct		Re-roof, re-side, gutters, window w	13,461.00
98486	Jesus Rodriguez	208 N Nebraska Ave		Re-roof	6,280.00
98487	Erik Ackland	415 N Academy Ave		Re-roof	9,350.00
98488	Jimmy Bailey	612 W 7th St		Re-roof, siding repair	11,900.00
98489	Shannon Legg	3525 S Lincoln Ave		Re-roof	21,371.00
98490	Kim Heinz	603 W Walnut St		Re-roof	15,380.00
98491	Kylee Troutman	1304 N Iowa Ave		Re-roof, siding repair	12,000.00
98492	Derek Lunzmann	2433 E 15th St		Deck Addition	15,000.00
98493	Oscar Mavin	120 W 11th St		Interior Remodel - Kitchen	2,000.00
98494	Jacob Moore	503 E 12th St		Re-roof	6,123.00
98495	Roger Pracheil	929 S Country Club Ave		Re-roof	14,378.00
98496	Paul Becker	2116 E 16th St		Re-roof, re-side, gutters	22,000.00
98497	Vicki Hesson	13 Arbor Hts		Re-roof	11,800.00
98498	Horizontal Boring	1128/1130 W Nobes Rd		Re-roof	9,200.00
98499	Marlin Hartig	1019 E 14th St		Re-roof	10,200.00
98500	Roger Magnussen	802 S Cowan Ave		Re-roof	10,000.00
98501	Mike Heath	223 Cedar Trail		Re-roof	22,000.00
98503	Lincoln Rentals	1037 Elmer Ave		Replace sidewalk	1,000.00

	OWNER	ADDRESS	LEGAL DESCRIPTION	DESCRIPTION	AMOUNT
98504	Twyla Mingus	1619 N Platte Ave		Siding & windows	5,350.00
98502	Jane Lott	30 Eastridge Dr S		Re-roof	14,500.00
98505	Stephen Gray	828 Elmer Ave		Re-roof	9,000.00
98506	Raymond Rison	106 E 11th St		Re-roof & re-side	18,000.00
98507	Raymond Rison	1021 N Grant Ave		Re-roof & re-side	18,000.00
98508	Urgent Care	309 S Lincoln Ave		Sign	5,500.00
98509	Urgent Care	309 S Lincoln Ave		Sign	800.00
98510	Nicholas McCarthy	1622 N Delaware Ave		Installing 56-370w PV Modules on	63,196.00
98511	Kenneth Parr	1021 N Blackburn Ave		Re-roof & re-side	20,000.00
98512	Montgomery Rahder	1600 N Delaware Ave		Re-roof & re-side	25,000.00
98513	Dan Peters	223 N Grant Ave		Re-roof & re-side	6,000.00
98514	Dennis Dahlgren	629 Kingsley Ave		Re-roof & re-side	15,000.00
98515	Kristina Lamonde	34 Edison Ave		Replace fence	150.00
98516	Bill Newman	1618 N Grant Ave		Siding	10,000.00
98517	Cody Blum	1202 Kiplinger Ave		Re-roof	9,290.00
98518	Cole Plock	727 S Cowan Ave		Egress window, re-side	25,838.00
98519	Curtis Miller	1623 N Nebraska Ave		Re-roof	8,000.00
98520	Phil Krumrei	917 N Platte Ave		Re-side, interior drywall	200.00
98521	Frank Serna Jr	520 N East Ave		Re-roof, gutters & siding	16,500.00
98522	Mary Melby	15 Arbor Hts		6ft privacy fence	4,000.00
98523	Steve Foster	1421 E Lawn Plaza		Re-roof	9,200.00
98524	Leroy Taylor	317 Cedar Trail		Re-roof	15,600.00
98525	Mark Deep	904 S Cowan Ave		Re-roof	11,600.00
98526	Brian Tomniges	1534 N Michigan Ave		Re-roof	11,500.00

	OWNER	ADDRESS	LEGAL DESCRIPTION	DESCRIPTION	AMOUNT
98527	Mike Hinz	1202 Rd 15		Re-roof	17,900.00
98529	Amandi Magnani	420 N Iowa Ave		Re-roof	12,466.00
98530	Van Baxter	941 Parkridge Ct		Re-roof	9,950.00
98531	John Sozio	1138 E 6th St		Re-roof	7,500.00
98532	Edward Larkin	1914 N Delaware		Re-roof	16,991.71
98533	Bruce Fagot	136 S Michigan Ave		Re-roof	11,600.00
98534	Anna Verhoeft	2202 E 16th St		Re-roof	19,075.00
98535	Ayla McCarty	628 East Ave N		Re-roof	12,060.00
98536	Rex Kircher	641 E 6th St		Re-roof	15,946.00
98537	Brittney Garretson	528 N Florida Ave		Re-roof & re-side	20,000.00
98538	Don Robb	1429 N Pennsylvania Ave		Re-roof	12,000.00
98539	Janelle Vice	1807 Platte Ave		Re-roof & re-side	20,000.00
98540	Ted Matousek	1823 N Grant Ave		Re-roof & re-side	30,000.00
98542	Jim Koester	1106 N Wisconsin Ave		Re-roof	12,900.00
98543	Brandon Lubke	145 Ash Ave		Replace shed	6,000.00
98544	Preston Burk	517 N Ohio Ave		Re-roof & gutters	11,000.00
98545	Living Water Rescue Mission	701 S Lincoln Ave		Shed	2,600.00
98548	Donna Kath	1505 E 6th St		Repair existing fence	1,047.73
98549	Pauline Johnson	1418 E Lawn Plaza Dr		Re-roof	8,161.00
98550	Fred Steinmetz	802 N Florida Ave		Re-roof	6,934.00
98551	Ryan Hansen	320 East Ave		Re-roof, re-side & gutters	10,000.00
98552	Merlin Warnken	19 Arbor Ct		Re-roof & gutters	9,000.00
98553	Alyssa Sanchez	619 W 7th St		Re-roof, re-side & gutters	8,000.00
98554	Teresa Schultz	514 E 19th St		Re-roof, re-side & gutters	10,000.00

OWNER	ADDRESS	LEGAL DESCRIPTION	DESCRIPTION	AMOUNT
98555	Dylan McGowan	1407 N Pennsylvania Ave	Re-roof & gutters	8,000.00
98556	Tanner Niemoth	927 Elmer Ave	Re-roof & gutters	8,000.00
98557	Brett Ehmen	906 W Nobes Rd	Re-roof & gutters	11,000.00
98558	Adam Peters	939 E Nobes Rd	Re-roof & re-side	8,000.00
98559	Doug Travis	636 W 7th St	Re-roof, siding & gutters	20,000.00
98560	Bruce Wagner	1205 Rd N	Re-roof, gutters & re-side	36,300.00
98561	Mariana Kelly	1624 N Lincoln Ave	Re-roof	8,000.00
98562	Henderson Bank	901 N Grant Ave	Re-roof	18,233.00
98563	Gail Nordlund	1345 Meadow Ln	Re-roof & gutters	13,976.00
98564	T & M Rentals LLC	1614 Iowa Ave	Re-roof & windows	20,000.00
98565	Ben & Tracey Babcock	2190 E 4th St	New Single Family Dwelling	423,890.13
98566	Ben Babcock	2190 E 4th St	Shop addition	83,505.60
98567	Tucker Boss	1 Eastridge Dr S	Re-roof	7,000.00
98568	Shawna Culotta	1342 Meadow Ln	Re-roof & gutters	11,343.00
98569	Apex Electric	202 N Lincoln Ave	Remodel office area in unit #3	8,000.00
98570	Cullen Sila	31 Arbor Ct	Re-roof, gutters, siding & wraps	17,800.00
98571	Chris Miller	32 Arbor Ct	Re-roof & gutters	7,400.00
98572	Marcelino Garcia	928 N Iowa Ave	Re-roof & windows	15,000.00
98574	Nick Kerwood	320 E 4th St	Fence	5,800.00
98575	Rob Schmidt	719 E 7th St	Re-roof	14,357.00
98576	Matt Wagner	114 N Blackburn Ave	Re-roof & gutters	35,750.00
98577	Leeann Hampton	116 N Burlington Ave	Re-roof & gutters	12,600.00
98578	Sheila Kulhanek	2010 N Nebraska Ave	Re-roof & gutters	12,100.00
98579	Elizabeth Scherbarth	1923 N Nebraska Ave	Re-roof & gutters	15,700.00

OWNER	ADDRESS	LEGAL DESCRIPTION	DESCRIPTION	AMOUNT
98580	Myrna Staehr	1524 N Michigan Ave	Re-roof & gutters	23,300.00
98581	James McDuffee	1114 Poplar Ave	Re-roof & gutters	17,000.00
98582	Joshua Nissen	1005 Mayhew Ave	Re-roof & gutters	10,400.00
98583	Tyler Cox	1100 Lincoln Ave	Remodel office - tear down office w	40,000.00
98584	Riley Friesen	821 N Burlington Ave	Re-roof, re-side & gutters	13,500.00
98585	Dan Goodwin	429 S Paradise Ln	Patio	13,000.00
98586	Nathan Gauss	904 N Maine	Re-roof	12,000.00
98587	Charles Harder	2025 Kentucky	Re-roof	9,000.00
98588	Dai Mathers	950 E 4th St	Re-roof & gutters	6,799.88
98589	Troy Miller	1219 N Indiana Ave	Re-roof, gutters & fascia	16,000.00
98590	Leslie Gubbles	219 S Blackburn Ave	Re-roof, siding & fascia	23,000.00
98591	Brian Jackson	921 Valley View Ct	Re-roof & gutters	8,700.00
98592	Kevin Stuhr	1327 Michigan Ave	Re-roof, gutters & siding	18,000.00
98593	Jodi Harcrow	1023 N Blackburn Ave	Re-roof, gutters & re-side	15,000.00
98594	Troy Flint	1500 Kennedy Dr	Re-roof & re-side	20,000.00
98595	Matt Shaw	123 N Grant Ave	Re-roof	6,000.00
98596	Dean Fredericks	10 Eastridge Dr S	Re-roof	13,200.00
98597	Ron Dedlow	1515 Duke Dr	Re-roof	18,000.00
98598	York University	1810 E 12th St	6 ft wooden privacy fence	15,870.00
98599	Cheryl Couch	312 N Blackburn Ave	Re-roof & gutters	7,500.00
98600	Walmart	101 David Dr	Re-roof & fix hail damage	611,000.00
98601	York Creekside Apartments	305 E Nobes Rd	Re-roof	210,000.00
98602	Julie Waegli	668 E 10th St	Re-roof & gutters	10,000.00
98603	Bob Sautter	7 Eastridge Ave	Re-roof roof & gutters	18,036.00

OWNER	ADDRESS	LEGAL DESCRIPTION	DESCRIPTION	AMOUNT
98604	Thelma Bergren 2331 S Lincoln Ave		Re-roof & siding repairs	34,700.00
98605	Dennis Dooley 331 S Delaware Ave		Re-roof & re-side	72,600.00
98627	City of York 211 E 7th St		Playground	120,178.00
98626	City of York 2222 E 14th St		Playground	1,200,000.00
98625	Russ Coffey 2329 E 15th St		Re-roof, re-side & gutters	26,000.00
98624	John Barrett 202 N Burlington Ave		Re-roof	8,100.00
98623	Jena Wullenwaber 403 N East Ave		Re-roof & re-side	25,000.00
98622	Alan & Teresa Hromas 927 N York Ave		Re-roof	15,000.00
98621	Robbie Sikes 705 E 19th St		Re-roof	17,778.00
98620	Dawn Sikes 1604 Raell Dr		Re-roof	14,338.00
98619	Sherry Hallisey 1320 N Pennsylvania Ave		Re-roof	8,766.00
98618	Warren Washburn 16 Country Club Hts		Re-roof	7,750.00
98617	Mariah Johnson 1211 N Pennsylvania Ave		Re-roof & gutters	18,000.00
98616	Preston Bolte 1707 E 10th St		Re-roof & gutters	9,500.00
98615	Kevin Postier 7 Quail Cove Rd		Re-roof	23,629.00
98614	Gayle Minert 915 Woodcrest Ct		Repair Fence	7,500.00
98613	Dianne Torson 1331 Pennsylvania Ave		Re-roof	10,000.00
98612	Stephen Junge 1322 Michigan Ave		Re-roof	10,000.00
98611	Eric Bowden 1522 E 4th St		Re-roof	12,000.00
98610	Jessican Hansen 644 E 7th St		Re-roof & re-side	38,549.00
98609	Robert Smart 1009 N East Ave		Re-roof	17,475.60
98608	Judy Johnson 1516 Kennedy Dr		Re-roof	7,548.00
98628	Steve Endicott 1022 N Maine Ave		Re-roof	12,000.00
98472	Susan Keller 130 S Florida Ave		Re-roof	6,000.00

OWNER	ADDRESS	LEGAL DESCRIPTION	DESCRIPTION	AMOUNT
98471	Ray Boston	402 N Michigan	Re-roof & re-side	17,000.00
98640	Boyd Anderson	312 E South 13th St	Re-roof	25,000.00
98639	Paul Moore	1703 N Iowa Ave	Re-roof & re-side	13,000.00
98638	Derek Daue	325 N Academy	Replace driveway	7,500.00
98636	Linda Smith	99 S Platte	Re-roof & re-side	24,000.00
98635	Melanie Robinson	624 E 6th St	Re-roof, gutters, re-side, replace win	27,900.00
98633	Grace & Stan Schulz	659 E 9th St	Re-roof	7,000.00
98632	Ben Emeigh	2 Eastridge Dr S	Replace fence	11,400.00
98629	Connie Shockey	38 Edison Ave	Re-roof & gutters	11,000.00
98644	Todd Hellerich	1405 Rael Dr	Re-roof & gutters	14,000.00
98643	LouAnn Bieck	1019 N Beaver	Re-roof	11,900.00
98641	Cameron Goeke	1228 N Florida	Re-roof, re-side & gutters	22,170.00

\$6,049,890.32

Permits Issued: 202

1. The first part of the document is a list of names and titles, including "The Hon. Mr. Justice G. D. C. O'Connell, Chief Justice of the Supreme Court of the State of New South Wales."

2. The second part of the document is a list of names and titles, including "The Hon. Mr. Justice G. D. C. O'Connell, Chief Justice of the Supreme Court of the State of New South Wales."

3. The third part of the document is a list of names and titles, including "The Hon. Mr. Justice G. D. C. O'Connell, Chief Justice of the Supreme Court of the State of New South Wales."

**Special Designated License
Local Recommendation (Form 200)**

Applications must be entered on the portal after local approval – no exceptions
Late applications are non-refundable and will be rejected

Sunset Bowl Inc
Retail Liquor License Name or *Non-Profit Organization (*Must include Form #201 as Page 2)

1923 N. Lincoln Ave York, NE 68467
Retail Liquor License Address or Non-Profit Business Address

078541
Retail License Number or Non-Profit Federal ID #

Consecutive Dates only
Event Date(s): Sep 10 _____

Event Start Time(s): 11:30 AM _____

Event End Time(s): 7:00 pm _____

Alternate Date: _____

Alternate Location Building & Address: _____

Event Building Name: Sunset Bowl

Event Street Address/City: 1923 N. Lincoln Ave

Indoor area to be licensed in length & width: ~~60~~ X ~~100~~

Outdoor area to be licensed in length & width: 60 X 100 (Diagram Form #109 must be attached)

Type of Event: Beer Garden Estimate # of attendees: 150

Type of alcohol to be served: Beer Wine Distilled Spirits
(If not marked, you will not be able to serve this type of alcohol)

Event Contact Name: Jan Hurlbut Event Contact Phone Number: 402-362-9923 402-366-3797

Event Contact Email: sunsetbowl@sunsetbowl.york.ne.com

*Signature Authorized Representative: Jan Hurlbut Printed Name Jan Hurlbut

I declare that I am the authorized representative of the above named license applicant and that the statements made on this application are true to the best of my knowledge and belief. I also consent to an investigation of my background including all records of every kind including police records. I agree to waive any rights or causes of action against the Nebraska Liquor Control Commission, the Nebraska State Patrol or any other individual releasing said information to the Liquor Control Commission or the Nebraska State Patrol. I further declare that the license applied for will not be used by any other person, group, organization or corporation for profit or not for profit and that the event will be supervised by persons directly responsible to the holder of this Special Designated License.

*Retail licensee – Must be signed by a member listed on permanent license
*Non-Profit Organization – Must be signed by a Corporate Officer

Local Governing Body completes below:

The local governing body for the City/Village of _____ **OR** County of _____ approves
the issuance of a Special Designated License as requested above. (Only one should be written above)

Local Governing Body Authorized Signature Date

OUTDOOR AREA DIAGRAM

HOW AREA WILL BE PATROLLED Area will be fenced in - Id's checked @ Entrance
Armbands used

- IF APPLICABLE, OUTDOOR AREA MUST BE CONNECTED TO INDOOR AREA IF INDOOR AREA IS TO LICENSED
- MEASUREMENT OF OUTER WALLS OF AREA TO BE LICENSED MUST INCLUDED LENGTH & WIDTH IN FEET
- DOUBLE FENCING IS REQUIRED FOR ALL NON-PROFIT ORGANIZATIONS UNLESS FORM #140 IS FILED WITH THIS FORM AND IS APPROVED BY THE COMMISSION
- RETAILER LIQUOR LICENSE HOLDERS ARE NOT REQUIRED TO DOUBLE FENCE, ALTHOUGH MEASURES NEED TO BE TAKEN TO SECURE THE AREA

DIAGRAM OF PROPOSED AREA:

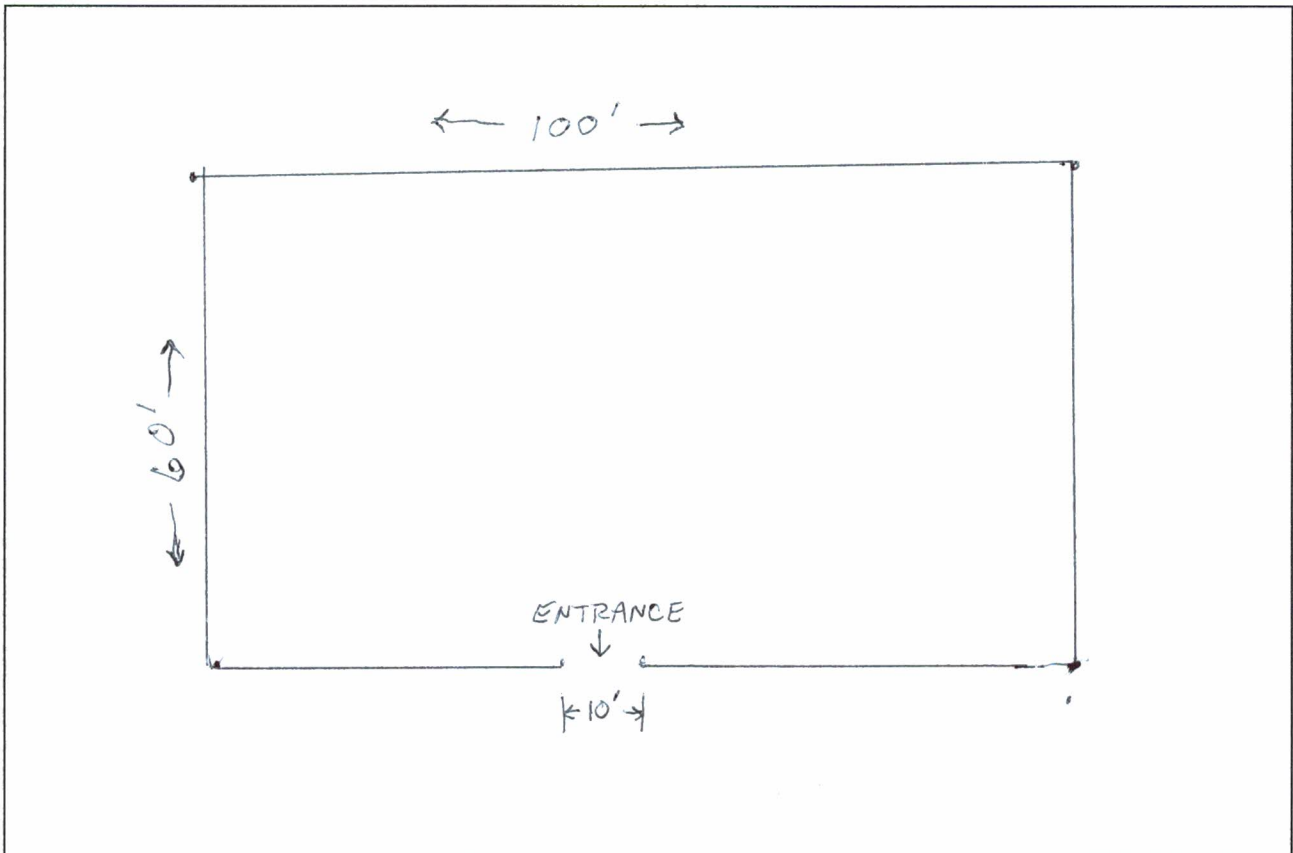

**Special Designated License
Local Recommendation (Form 200)**

Applications must be entered on the portal after local approval – no exceptions
Late applications are non-refundable and will be rejected

Greater Area York Chamber of Commerce

Retail Liquor License Name or *Non-Profit Organization (*Must include Form #201 as Page 2)

603 N Lincoln Ave, York, NE 68467

Retail Liquor License Address or Non-Profit Business Address

47-3041260

Retail License Number or Non-Profit Federal ID #

Consecutive Dates only 9/29/22
Event Date(s):

Event Start Time(s): 4:00 p.m.

Event End Time(s): 10:00 p.m.

Alternate Date: 10/6/22

Alternate Location Building & Address: N/A

Event Building Name: McNeill Floral Company

Event Street Address/City: 723 Lincoln Ave, York, NE 68467

Indoor area to be licensed in length & width: 100' X 30'

Outdoor area to be licensed in length & width: ___ X ___ (Diagram Form #109 must be attached)

Type of Event: Sip & Stroll Tasting Event Estimate # of attendees: 400

Type of alcohol to be served: Beer Wine Distilled Spirits
(If not marked, you will not be able to serve this type of alcohol)

Event Contact Name: Madonna Mogul Event Contact Phone Number: 402-362-5531

Event Contact Email: madonnam@yorkchamber.org

*Signature Authorized Representative:  Printed Name: Madonna Mogul

I declare that I am the authorized representative of the above named license applicant and that the statements made on this application are true to the best of my knowledge and belief. I also consent to an investigation of my background including all records of every kind including police records. I agree to waive any rights or causes of action against the Nebraska Liquor Control Commission, the Nebraska State Patrol or any other individual releasing said information to the Liquor Control Commission or the Nebraska State Patrol. I further declare that the license applied for will not be used by any other person, group, organization or corporation for profit or not for profit and that the event will be supervised by persons directly responsible to the holder of this Special Designated License.

*Retail licensee – Must be signed by a member listed on permanent license

*Non-Profit Organization – Must be signed by a Corporate Officer

Local Governing Body completes below:

The local governing body for the City/Village of _____ **OR** County of _____ approves the issuance of a Special Designated License as requested above. (Only one should be written above)

Local Governing Body Authorized Signature

Date

**Special Designated License
Local Recommendation (Form 200)**

Applications must be entered on the portal after local approval – no exceptions
Late applications are non-refundable and will be rejected

Greater Area York Chamber of Commerce

Retail Liquor License Name or *Non-Profit Organization (*Must include Form #201 as Page 2)

603 N Lincoln Ave, York, NE 68467

Retail Liquor License Address or Non-Profit Business Address

47-3041260

Retail License Number or Non-Profit Federal ID #

Consecutive Dates only

Event Date(s):

9/29/22

Event Start Time(s):

4:00 p.m.

Event End Time(s):

10:00 p.m.

Alternate Date: 10/6/22

Alternate Location Building & Address: N/A

Event Building Name: Impulse Salon & Spa

Event Street Address/City: 417 N Grant Ave, York, NE 68467

Indoor area to be licensed in length & width: 120' X 30'

Outdoor area to be licensed in length & width: ___ X ___ (Diagram Form #109 must be attached)

Type of Event: Sip & Stroll Tasting Event Estimate # of attendees: 400

Type of alcohol to be served: Beer Wine Distilled Spirits
(If not marked, you will not be able to serve this type of alcohol)

Event Contact Name: Madonna Mogul Event Contact Phone Number: 402-362-5531

Event Contact Email: madonnam@yorkchamber.org

*Signature Authorized Representative:  Printed Name: Madonna Mogul

I declare that I am the authorized representative of the above named license applicant and that the statements made on this application are true to the best of my knowledge and belief. I also consent to an investigation of my background including all records of every kind including police records. I agree to waive any rights or causes of action against the Nebraska Liquor Control Commission, the Nebraska State Patrol or any other individual releasing said information to the Liquor Control Commission or the Nebraska State Patrol. I further declare that the license applied for will not be used by any other person, group, organization or corporation for profit or not for profit and that the event will be supervised by persons directly responsible to the holder of this Special Designated License.

*Retail licensee – Must be signed by a member listed on permanent license

*Non-Profit Organization – Must be signed by a Corporate Officer

Local Governing Body completes below:

The local governing body for the City/Village of _____ **OR** County of _____ approves the issuance of a Special Designated License as requested above. (Only one should be written above)

Local Governing Body Authorized Signature

Date



Administrative Offices
P.O. Box 276
100 E. 4th Street
York, NE 68467

York Facade Improvement Program Application

Applicant Name: Tim and Jen Arndt
Applicant's Phone Number: 402 363-4591
Applicant's Email Address: mccormicks1.ta@gmail.com
Business Name: T&J rentals/ ~~4th Street Boutique~~
Property Owner: T&J Rentals
Property Address: 208 East 4th
Property Legal Description: LOT 13-15 BLK 76 OT CITY OF YORK

Type of façade improvement planned (see Design Guidelines)

Restoration Renovation Replacement Reconstruction

Structural alterations: None

Cosmetic alterations (i.e. moldings): Outdoor facade, new windows and store front

Painting (approximate sq. ft. area): 400

Interior Improvements: Yes, HVAC, new wall partitions, lighting, and floorcoverings

Specify other work (i.e. awnings): Possible Awning if budget allows

Total cost of project: \$85,000.00

DTR Project Funds Amount requested: \$50,000.00

I hereby submit the attached plans, specifications and color samples for the proposed project, and understand that these must be approved by the City of York. No work may begin until I have received

written notice to proceed from the City of York. I further understand that the project must be completed by November 20, 2023. Grant funds will not be paid until the project is commenced. If the City has not received correspondence in that time frame, the funds will be reallocated. I agree to leave the completed project in its approved design and colors for a period of five (5) years from the date of completion. If changed before the end of five (5) years, I agree to pay back the funded amount.

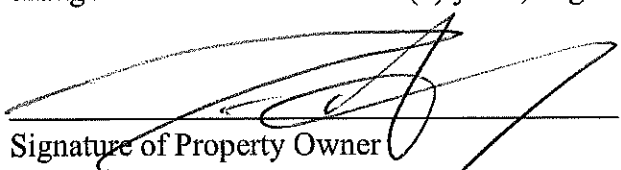
Signature of Property Owner

Timothy Arndt
Printed Name & Title of Property Owner

3/23/2022
Date

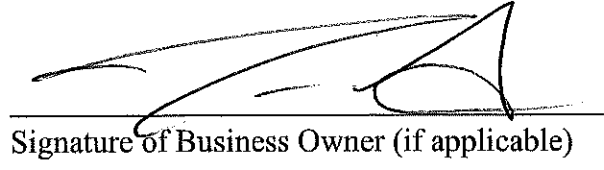
Signature of Business Owner (if applicable)

TAJ RENTALS
Printed Name & Title of Business Owner

3/23/22
Date

Applications to be sent to:

DTR Committee
603 N Lincoln Ave
York, NE 68467

Attestation of U.S. Citizenship

For the purpose of complying with Neb.Rev.Stat. §§4-108 through 4-114, I attest as follows:

I am a citizen of the United States

-OR-

I am a qualified alien under the Federal Immigration and Nationality Act, my immigration status and alien number are as follows:

_____, and I agree to provide a copy of my USCIS documentation upon request.

I hereby attest that my response and the information provided on this form and any related application for public benefits are true, complete and accurate and I understand that this information may be used to verify my lawful presence in the United States.

Printed Name:

Timothy A. Arndt
First Middle Last

Signature:



Date:

3/23/22

Release and Hold Harmless Agreement

Release executed on this 23 day of March, 2022,
by (Property Owner) Tim Arndt and
(Business owner if applicable) _____, of
(Street Address) 208 E. 4th, City of York, State of
Nebraska, referred to as Releaser(s).

In consideration of being granted monies for restoration, modifications, or other physical changes to the property located at the above address, the Releaser(s), understands that they are solely responsible for providing their own contractors, paying their contractors, to assure that those contractors are fully insured and licensed, and have obtained all necessary permits in accordance with all pertinent regulations. The Releaser(s) waives, releases, discharges, and agrees to indemnify the City of York (or entities under the City's umbrella), for loss or damage, and claims or damages therefore, on account of any work that has been performed in accordance with City or State guidelines.

Releaser(s) agrees that this release, waiver, and indemnity agreement is intended to be as broad and inclusive as permitted by the laws of the State of Nebraska and that if any portion of the agreement is held invalid, it is agreed that the balance shall; notwithstanding, continue in full legal force and effect.

Releaser's obligation and duties hereunder shall in no manner be limited or restricted by the maintaining of any insurance coverage related to the above referenced event.

This release contains the entire agreement between the parties to this agreement and the terms of this release are contractual and are not a mere recital.

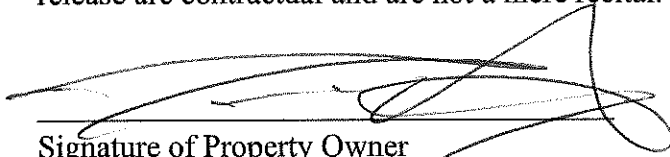

Signature of Property Owner

Timothy A. Arndt
Printed Name & Title of Property Owner

3/23/22
Date

Signature of Business owner (if applicable)

Printed Name & Title of Business Owner

Date



4th & York Ave - PO Box 147
York, Nebraska 68467
Ph: 402-362-3339
Fax 402-362-3330

COST PROPOSAL

Date 03/23/22

TO: Tim Arndt
York, NE 68467

REF: Arndt metal building exterior improvements

ATTN: Tim Arndt

**COST PROPOSAL FOR EXTERIOR IMPROVEMENTS TO
METAL BUILDING NORTH OF MCCORMICKS**

Scope of Work:
See attached scope of work sheet.

Cost Breakdown:

General Requirements	\$5,270
Sitework	\$1,600
Concrete	\$0
Masonry	\$8,500
Steel	\$0
Carpentry	\$0
Thermal	\$1,350
Openings	\$19,425
Finishes	\$5,275
Metal Building	\$35,000
Mechanical	\$0
Electrical	\$0
Subtotal	<u>\$76,420</u>
JLC O&P	<u>\$8,490</u>
Total proposal cost	<u>\$84,910</u>

DREW JENSEN
JLC INCORPORATED

Arndt building exterior improvements

SCOPE OF WORK

Division 1. General Requirements

1. Permit
2. Refuse Hauling
3. Supervision
4. Temporary toilet
5. Housekeeping
6. Final Cleaning
7. Equip/tools
8. Davis Bacon admin

Division 2. Sitework

1. Selective Demolition

Division 3. Concrete

1. NA

Division 4. Masonry

1. Thin stone up 3' at north and west elevations

Division 6. Carpentry

1. NA

Division 7. Thermal

1. Insulation
2. Joint Sealants

Division 8. Doors and Windows

1. Exterior hollow metal doors
2. Aluminum storefronts
3. Slider window

Division 9. Finishes

1. Gyp systems

Division 13. Special Construction- Metal Building

1. Wall sheeting
2. Roof Sheeting

Division 15. Mechanical

3. NA

Division 16. Electrical

1. NA

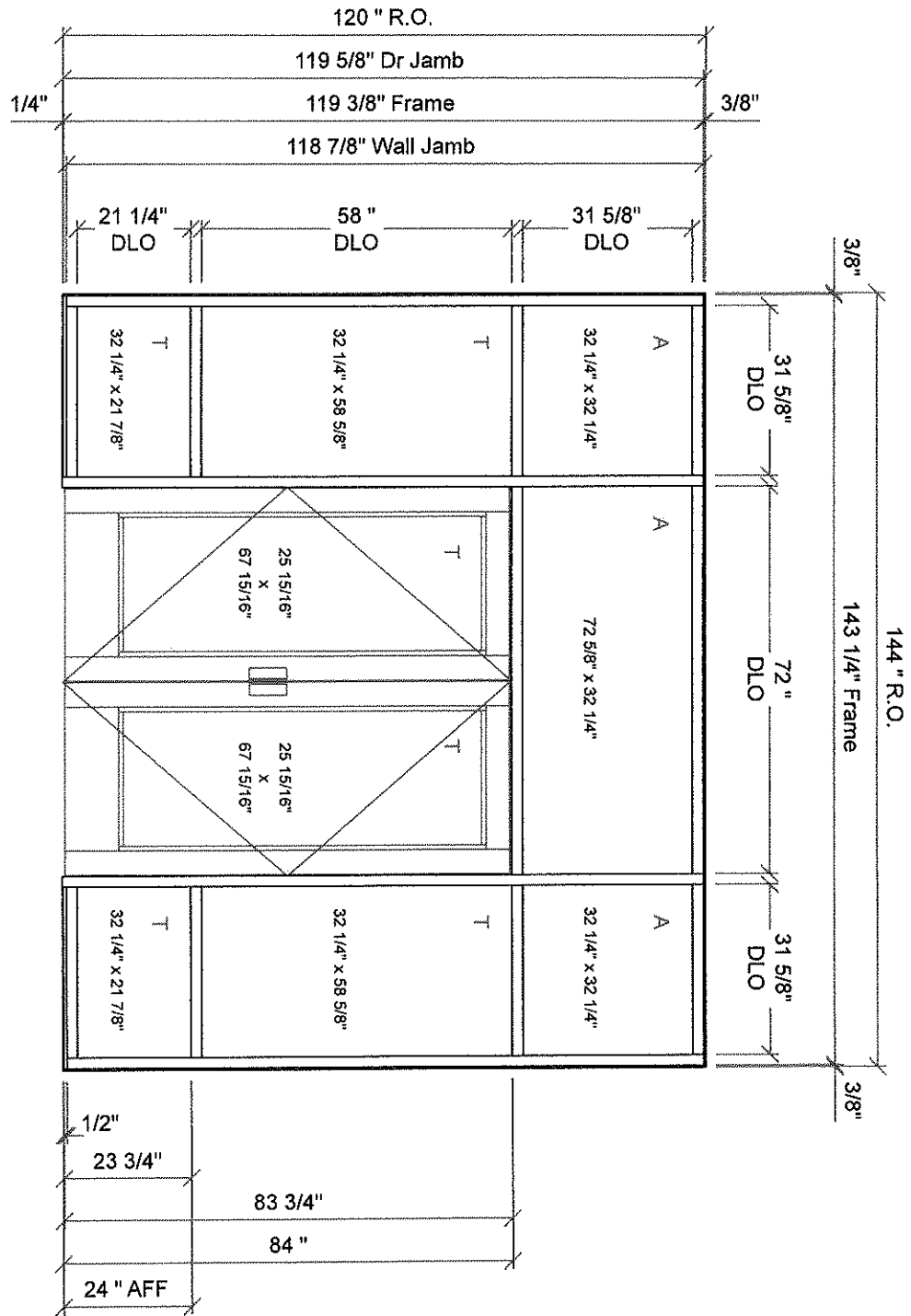

Harlow Homes Arndt - 001 - Pair of Doors at Garage (1 Thus)
 Frame: (Bronze) 2450 : 1in gl : 2in. Framing : Center - Outside Glaze Storefront
 3/15/2022

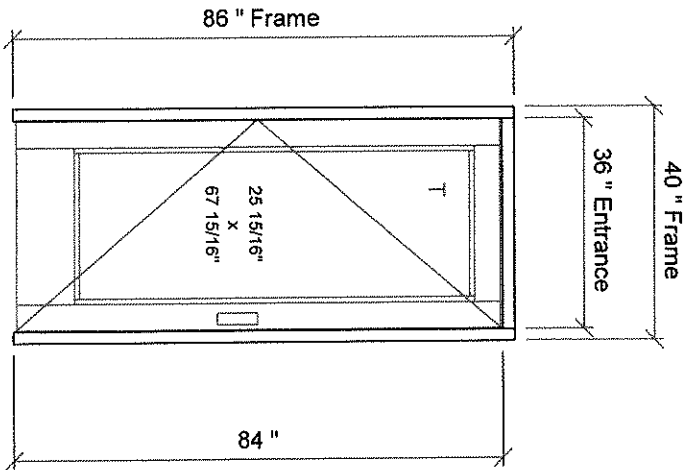

Harlow Homes Arndt - 002 - Single Door (1 Thus)
 Frame: (Bronze) 2450 : 1in gl : 2in. Framing : Center
 - Outside Glaze Storefront
 3/15/2022

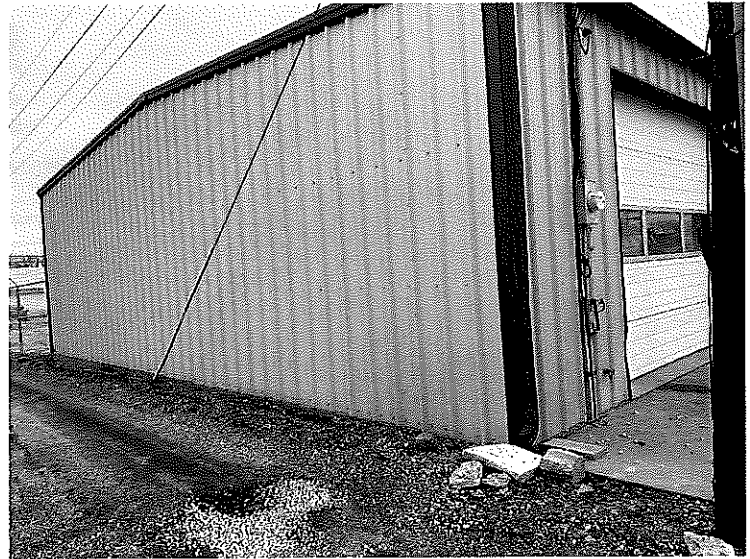
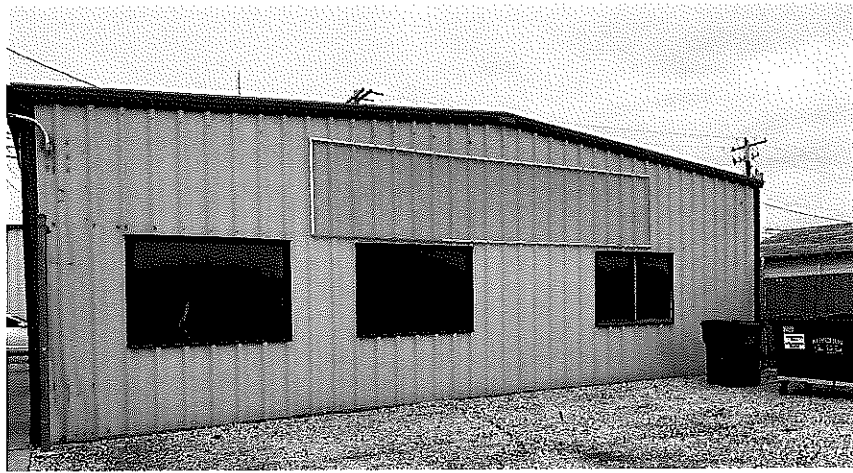

Tier II: Site Specific Environmental Review

Community Development Block Grant

Grant Number: #21-DTR-014

Grantee: T&J Rentals

Property Address 208 East 4th Street, York, NE 68467

Activity Description

The project includes the following activities: T&J Rentals has applied for the City of York's Façade Improvement Program. Restoration and renovation activities for this project consist of: Cosmetic alterations: Outdoor façade, new windows and storefront, Painting: 400 sq. ft., Interior improvements: HVAC, new wall partitions, lighting, and floor coverings, Other work: Possible new awning installation if budget allows

Cost:

- Projected Acquisition Cost \$0.00
- Projected Rehab Cost \$85,000.00
- Projected All Cost \$85,000.00

1. **Air Quality** [Clean Air Act sections 176(c) & (d), and 40 CFR 6, 51, 93] Steps used to address Radon must match rehab process as outlined in the program guidelines.

N/A

2. **Airport Hazards** [24 CFR 51D] Also provide a map showing the direct line distance between airport and each housing unit proposed for assistance.

N/A

4. **Contamination and Toxic Substances** [24 CFR 58.5(i)(2)]

- Visual review and pictures of site and surroundings conducted by [Ceylon Herath](#) on 08/04/2022
- The site review identified the following concerns on or adjacent to the project site:
[According to the site review, there are no concerns on or adjacent to the project site.](#)
- The EPA, <https://www.epa.gov/nepa/nepassist>, mapping web-tool was used. The following sites were identified on or near the site that may be a concern for the project
[There are no sites on or near the project site that may be a concern for the project.](#)
- The DEQ, <http://deqims2.deq.state.ne.us/deqflex/DEQ.html>, mapping web-tool was used. The following sites were identified on or near the site that may be a concern for the project
N/A
- The Fire Marshall was sent a letter on 08/04/2022 and is not attached.
- The Agency response letter noted that:
 - There were no Underground Storage Tanks (UST's) on or near the site.
 - There were Underground Storage Tanks (UST's) on or near the site.
 - These UST's included those located at:
[Click or tap here to enter text.](#)
- The following Attachments have also been included:

- Photographs
- Website
- Letter sent to Agency

- Response received back from Agency
- Maps
- Aerials

5. Endangered Species [50 CFR 402]

N/A

- Website
- Letter sent to Agency
- Response received back from Agency

6. Environmental Justice [Executive Order 12898]

- Is the proposed site located in or around a low-income or minority neighborhood?
 Yes No

The EPA, <https://www.epa.gov/ejscreen>, website tool was used. The following sites were identified on or near the site that may be a concern for the project

N/A

- Based on the above information, is the site located in a suitable, safe, and sanitary living environment?
 Yes No (Site should be rejected)

7. Explosive and Flammable Operations [24 CFR 51C]

- Visual review and pictures of site and surroundings conducted by [Ceylon Herath](#) on 08/04/2022.
 No known explosive or flammable operations were visible on or near the site.
 Explosive or flammable operations were visible on or near the site.
 - The site review identified the following concerns on or adjacent to the project site: There were no identifiable concerns on or adjacent to the project site.

8. Farmland Protection [7 CFR 658]

N/A

9. Floodplain Management [24 CFR 55, Executive Order 11988]

- Site is not located within a SFHA (100 year floodplain).
- The attached FEMA FIRM map was reviewed and indicates the site is not located in a Special Flood Hazard Area (SFHA). [\[See attached FIRM Map\]](#)
- Review DED's website for additional guidance within the related funding source manual.

10. Historic Preservation [36 CFR 800]

- The structure was built in the year: N/A
- A site review and photos of the property were completed on the following date: N/A
- Based on the review, it has been determined that the structure is:
 - Historic
 - Not historic
- It has also been determined that the rehab activities proposed in the project

- Will not impact any historic resources.
- May impact historic resources which may include the home or nearby houses or structures.
- A letter determining whether or not any historic resources might be impacted by the project, along with photos of the site, an aerial map of the residence, and a list of proposed activities were sent to the
 - SHPO on the following date: 07/14/2022
 - THPO on the following date: N/A
- SHPO response was received back on the following date: 07/18/2022
- SHPO noted **No historic properties affected.**
- THPO response was received back on the following date: N/A
- THPO noted N/A
- The following Attachments have also been included:

<input type="checkbox"/> Photographs	<input checked="" type="checkbox"/> Documentation showing SHPO was contacted
<input type="checkbox"/> Website	<input type="checkbox"/> Documentation showing THPO was contacted
<input type="checkbox"/> Maps	<input checked="" type="checkbox"/> Response received back from Nebraska SHPO
	<input type="checkbox"/> Aerials

11. Noise Control [24 CFR 51B]

- The proposed site is located within
 - _____ Feet of a busy/major roadway
 - _____ Feet of a railway
 - _____ Miles from a civil airport or military airfield
 - _____ Miles from any community airport
- Attach an aerial map(s), which includes the site marked, and map scale as documentation.
- Based on the above mentioned review, the proposed site is located within an acceptable noise environment, and no further evaluation is needed.
- Based on the above mentioned review, the proposed site is located within
 - 1,000 feet of a busy/major roadway
 - 3,000 feet of a railway
 - 15 miles from a civil airport or military airfield
- The site may be located within a normally unacceptable or unacceptable noise environment.
N/A
- A description of the noise attenuation measures that will be incorporated during the rehabilitation include:
N/A
- The comprehensive scope of weatherization improvements include:
N/A

13. Wetland Protection [24 CFR 55, Executive Order 11990]

N/A

14. Wild and Scenic Rivers [36 CFR 297]

N/A

58.6 Requirements, Flood Disaster Protection Act

Site is not located within a SFHA (100 year floodplain).

- The attached FEMA FIRM map _____ [Map #, Panel #] was reviewed and indicates the site is not located in a Special Flood Hazard Area (SFHA). [N/A]
- No FIRM map was available for the site. _____ was contacted on _____ and the attached information indicates the site is not located in a Special Flood Hazard Area (SFHA). [N/A]

Site is located within a SFHA (100 year floodplain).

- The attached FEMA FIRM map _____ [Map #, Panel #] was reviewed and indicates the site is located in a Special Flood Hazard Area (SFHA). [Attach the FIRM Map]
- No FIRM map was available for the site. _____ was contacted on _____ and the attached information indicates the site is located in a Special Flood Hazard Area (SFHA). [Attach source]
- Due to the location of the site, the property
 - Does not require the purchase of flood insurance
 - Requires the purchase of flood insurance. [Attach evidence the community is participating in the National Insurance Program and a copy of the flood insurance policy]

A site specific environmental review has been performed at the above location in compliance with HUD environmental review regulations (24 CFR 58) and related laws, authorities, and requirements. The review has been performed prior to the commitment of HUD or non-HUD funds, as required by 24 CFR 58.22(a) and (c).

This review shall be retained as a component of the project's ERR. Consult the Tier I for further information as to compliance with other laws and authorities for this HUD-assisted project.

Ceylon J. Herath

Preparer Name

Ceylon J. Herath 8/8/22

Preparer Signature

Date

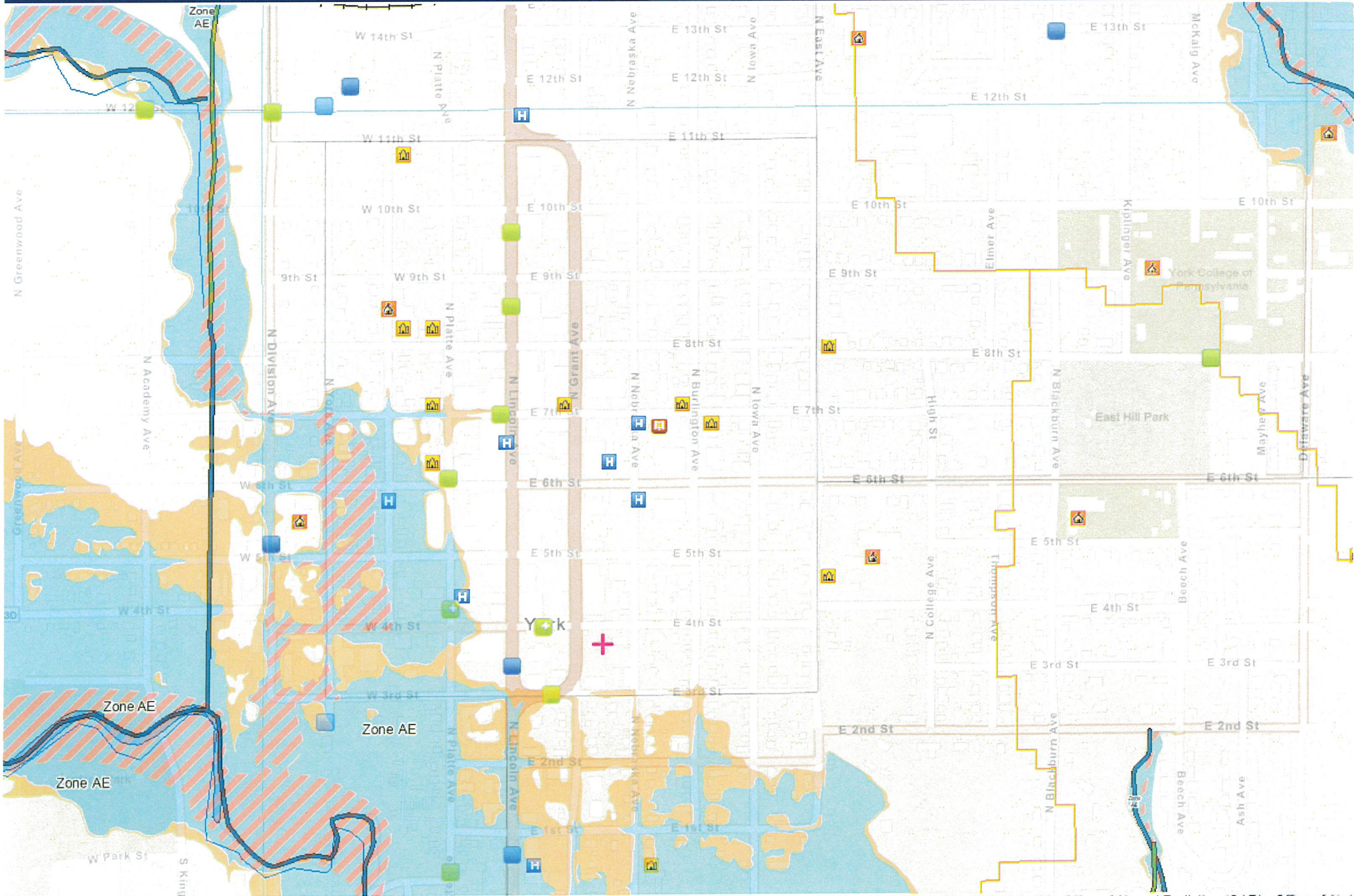



History
NEBRASKA
HISTORIC PRESERVATION

ONLINE SECTION 106 PROJECT FORM FOR
INDIVIDUAL STANDING STRUCTURES

History Nebraska

NESHPO Use Only

Date Received
JUL 18 2022

HP Number

2207-032-01

Submission of a completed Project Information Form with adequate information and attachments constitutes a request for review pursuant to Section 106 of the National Historic Preservation Act of 1966 (as amended). More information may be required to complete the Section 106 process. Submit completed form to HN.HP@nebraska.gov.

NOTE: Section 106 regulations provide for a 30-day response time by the Nebraska State Historic Preservation Office from the date of receipt.

PROJECT NAME (if applicable)

York Downtown Revitalization Phase IV

COUNTY

York

STREET ADDRESS (No P.O. Box Numbers)

208 East 4th Street

FEDERAL AGENCY OR DESIGNEE

HUD-Community Development Block Grant (CDBG)/Southeast Nebraska Development District (SEND) (SENDD)

CONTACT PERSON

Ceylon Herath

CITY, STATE ZIP

7407 O Street, Lincoln, NE 68510

TELEPHONE

4024752560

EMAIL (for response)

cherath@sendd.org

PROJECT NUMBER
(if applicable)

#21-DTR-014

CITY

York

PROJECT DESCRIPTION

Briefly describe the overall project.

The project includes the following activities: T&J Rentals has applied for the City of York's Facade Improvement Program. Restoration and renovation activities for this project consist of:

Cosmetic alterations: Outdoor facade, new windows and storefront

Painting: 400 sq. ft.

Interior improvements: HVAC, new wall partitions, lighting, and floor coverings

Other work: Possible new awning installation if budget allows

DESIGNATIONS

To the best of your knowledge, is the structure any of the following?

- Listed Individually on the National Register Listed within a National Register Historic District
- Designated Local Landmark Designated Local Landmark District

PHOTOGRAPHS

Please provide photographs of all structures. Photographs of neighboring or nearby buildings are helpful. Go to page 2 to insert photo(s).

NESHPO USE ONLY

Nebraska SHPO Determination

Site Number: _____

- No potential to cause effects Adverse effect (More consultation needed)
- No historic properties affected The SHPO requests additional information (see attached)
- No adverse effect

Beth M. Kelly
Review & Compliance Coordinator
State Historic Preservation Office, Nebraska State Historical Society

Date 7/19/22



Administrative Offices
P.O. Box 276
100 E. 4th Street
York, NE 68467

York Facade Improvement Program Application

Applicant Name: Bradley Dose
Dose Management LLC

Applicant's Phone Number: 402-694-1284 or 402-658-4880

Applicant's Email Address: Dosemgmt@yahoo.com

Business Name: Dose Management LLC

Property Owner: Bradley Dose

Property Address: 623 N. Grant Ave York, Ne 68467

Property Legal Description: _____

Type of façade improvement planned (see Design Guidelines)

Restoration Renovation Replacement Reconstruction

Structural alterations: Paint a Tuck Point

Cosmetic alterations (i.e. moldings): _____

Painting (approximate sq. ft. area): _____

Interior Improvements: _____

Specify other work (i.e. awnings): _____

Total cost of project: ~~75,280~~ 89,428.00

DTR Project Funds Amount requested: \$ 50,000

Owner invest 25,280 39,428
60

I hereby submit the attached plans, specifications and color samples for the proposed project, and understand that these must be approved by the City of York. No work may begin until I have received written notice to proceed from the City of York. I further understand that the project must be completed by November 20, 2023. Grant funds will not be paid until the project is commenced. If the City has not received correspondence in that time frame, the funds will be reallocated. I agree to leave the completed project in its approved design and colors for a period of five (5) years from the date of completion. If changed before the end of five (5) years, I agree to pay back the funded amount.

Bradley L. Dose

Signature of Property Owner

Signature of Business Owner (if applicable)

Bradley L. Dose Vice President

Printed Name & Title of Property Owner

Printed Name & Title of Business Owner

3-1-22

Date

Date

Applications to be sent to:

DTR Committee
603 N Lincoln Ave
York, NE 68467

Release and Hold Harmless Agreement

Release executed on this _____ day of _____,
by (Property Owner) _____ and
(Business owner if applicable) _____, of
(Street Address) 623 N. Grant Ave, City of York, State of
Nebraska, referred to as Releaser(s).

In consideration of being granted monies for restoration, modifications, or other physical changes to the property located at the above address, the Releaser(s), understands that they are solely responsible for providing their own contractors, paying their contractors, to assure that those contractors are fully insured and licensed, and have obtained all necessary permits in accordance with all pertinent regulations. The Releaser(s) waives, releases, discharges, and agrees to indemnify the City of York (or entities under the City's umbrella), for loss or damage, and claims or damages therefore, on account of any work that has been performed in accordance with City or State guidelines.

Releaser(s) agrees that this release, waiver, and indemnity agreement is intended to be as broad and inclusive as permitted by the laws of the State of Nebraska and that if any portion of the agreement is held invalid, it is agreed that the balance shall, notwithstanding, continue in full legal force and effect.

Releaser's obligation and duties hereunder shall in no manner be limited or restricted by the maintaining of any insurance coverage related to the above referenced event.

This release contains the entire agreement between the parties to this agreement and the terms of this release are contractual and are not a mere recital.



Signature of Property Owner

Bradley J. Dose Vice
President

Printed Name & Title of Property Owner

3-1-22

Date

Signature of Business owner (if applicable)

Printed Name & Title of Business Owner

Date

Attestation of U.S. Citizenship

For the purpose of complying with Neb.Rev.Stat. §§4-108 through 4-114, I attest as follows:

I am a citizen of the United States

-OR-

I am a qualified alien under the Federal Immigration and Nationality Act, my immigration status and alien number are as follows:

_____, and I agree to provide a copy of my USCIS documentation upon request.

I hereby attest that my response and the information provided on this form and any related application for public benefits are true, complete and accurate and I understand that this information may be used to verify my lawful presence in the United States.

Printed Name:

Bradley L Dose
First Middle Last

Signature:

Bradley L. Dose

Date:

3-1-22

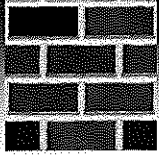

Gagner Restoration, Inc.

Proposal

1992 Lake Street, Lincoln, NE 68502
Phone 402.474.6557 Fax 402.474.6560
myron@gagnerrestoration.com

DATE: MARCH 29, 2022

PROPOSAL SUBMITTED TO: Dose Management
York NE.
dosegmt@yahoo.com

Job Name: Masonry Repair
Job Location:
Bid No.: 11148
Phone N.: 402-658-4880

WE HEREBY SUBMIT SPECIFICATIONS AND ESTIMATES FOR:

Grout Masonry as needed:

- 1. East Elevations
- 2. South Elevation as far back as boom will reach

Total-----	\$22,488.00
Water blast all elevations-----	\$15,792.00
Apply 2 coats paint a south, east & west elevations-----	\$51,148.00

Terms: A 50% down payment is required with the signing of the proposal;
The balance is due at completion of the work.

We Propose hereby to furnish material and labor - complete in accordance with above specification, for the sum of:

_____ Per above _____ dollars (\$ ___ per above _____)

Note: This proposal may be withdrawn by us if not accepted within 30 days.

Payment to be made as follows: Payment is due at completion of work. A service charge of 1½% per month, 18% APR, will be charged on all accounts over 30 days.

Quotation prepared by: Myron L. Gagner

Acceptance of Proposal - The above prices, specifications and conditions are satisfactory and are hereby accepted. You are authorized to do the work as specified. Payment will be made as outlined above.

To accept this quotation, sign here and return: _____

Date of Acceptance: _____

THANK YOU FOR YOUR BUSINESS!

243921

Purchase Order

TO Dase Management		GROUP TO Crime Painting	
ADDRESS 623 N Great Ave		ADDRESS 1710 N 25th Street	
CITY, STATE, ZIP York NE		CITY, STATE, ZIP Lincoln NE 68503	
DATE	DATE IN QUOTE	QUANTITY	UNIT PRICE

QTY	DESCRIPTION	PRICE	UNIT
1	prep windows and doors		
2			
3			
4	little bit scraping		
5			
6	prime Red spots		
7			
8	paint one coat whole Building		
9			
10			
11			
12			
13			
14			
15			
16			
17			
18			
19			
20			
21			
22			
23			
24			
25			
26			
27			
28			
29			
30			
31			
32			
33			
34			
35			
36			
37			
38			
39			
40			
41			
42			
43			
44			
45			
46			
47			
48			
49			
50			
51			
52			
53			
54			
55			
56			
57			
58			
59			
60			
61			
62			
63			
64			
65			
66			
67			
68			
69			
70			
71			
72			
73			
74			
75			
76			
77			
78			
79			
80			
81			
82			
83			
84			
85			
86			
87			
88			
89			
90			
91			
92			
93			
94			
95			
96			
97			
98			
99			
100			

\$37,000

IMPORTANT

Purchase Order Number must appear on all invoices - packaging, etc.
Please notify us immediately if you are unable to complete the order by date specified.

Please send _____ copies of your INVOICE with ORIGINAL BILL OF LADING

PURCHASING AGENT

ORIGINAL

Madonna Mogul

From: brad dose <dosemgmt@yahoo.com>
Sent: Wednesday, April 27, 2022 10:38 AM
To: Madonna Mogul
Subject: Fw: Grant tuck pointing, Dose Mgmt

Sent from Yahoo Mail on Android

----- Forwarded Message -----

From: "dcarpenter2@neb.rr.com" <dcarpenter2@neb.rr.com>
To: "dosemgmt@yahoo.com" <dosemgmt@yahoo.com>
Sent: Wed, Apr 27, 2022 at 6:26 AM
Subject: Grant tuck pointing

PROPOSAL 4-26-2022

Dose Management

Job—

623 Grant Ave.

York, NE.

Masonry work---Costs include all scaffolding; materials and labor to complete tuck pointing on the south, east and west sides of building---

Total---\$52,000.

Submitted by,

Doug Carpenter

Carpenter Masonry Inc.

7644 Kennelley Drive

Lincoln, NE. 68516



Virus-free. www.avg.com

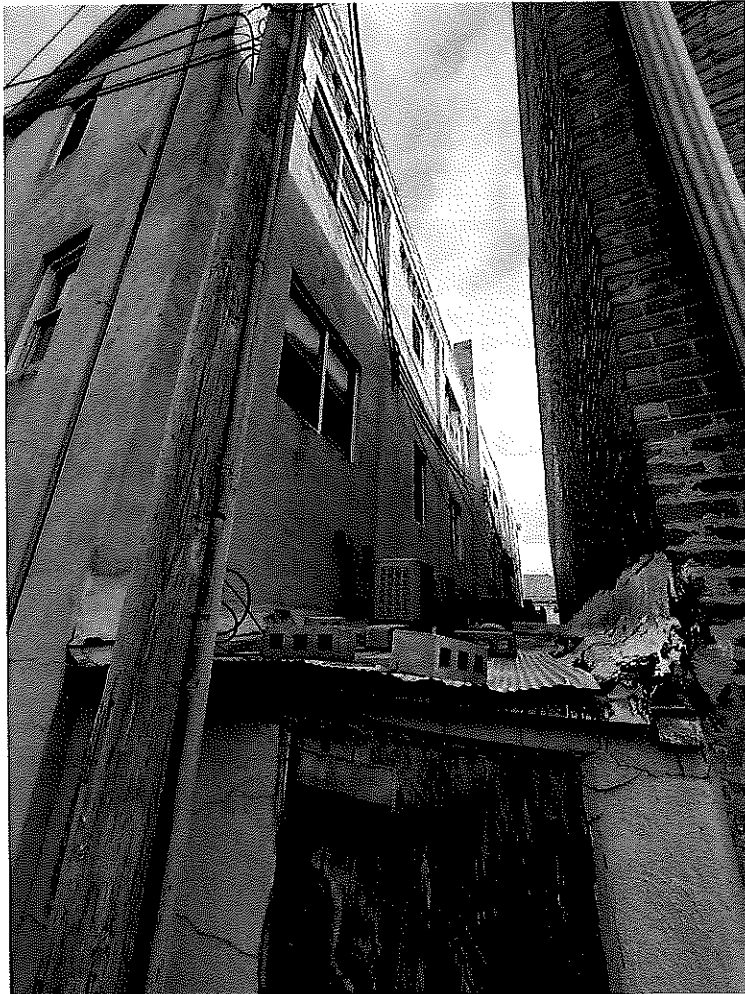

Tier II: Site Specific Environmental Review

Community Development Block Grant

Grant Number: #21-DTR-014

Grantee: Dose Management, LLC

Property Address 623 N. Grant Avenue, York, NE 68467

Activity Description

The project includes the following activities: Dose Management, LLC in York, NE has applied for the City of York's Façade Improvement Program. Structural alterations for this project consist of: Painting a tuck point.

Cost:

- Projected Acquisition Cost **\$0.00**
- Projected Rehab Cost **\$89, 428.00**
- Projected All Cost **\$89, 428.00**

1. **Air Quality** [Clean Air Act sections 176(c) & (d), and 40 CFR 6, 51, 93] Steps used to address Radon must match rehab process as outlined in the program guidelines.

N/A

2. **Airport Hazards** [24 CFR 51D] Also provide a map showing the direct line distance between airport and each housing unit proposed for assistance.

N/A

4. **Contamination and Toxic Substances** [24 CFR 58.5(i)(2)]

- Visual review and pictures of site and surroundings conducted by [Ceylon Herath](#) on 08/04/2022
- The site review identified the following concerns on or adjacent to the project site:
[According to the site review, there are no concerns on or adjacent to the project site.](#)
- The EPA, <https://www.epa.gov/nepa/nepassist>, mapping web-tool was used. The following sites were identified on or near the site that may be a concern for the project
[There are no sites on or near the project site that may be a concern for the project.](#)
- The DEQ, <http://deqims2.deq.state.ne.us/deqflex/DEQ.html>, mapping web-tool was used. The following sites were identified on or near the site that may be a concern for the project
[N/A](#)
- The Fire Marshall was sent a letter on 08/04/2022 and is not attached.
- The Agency response letter noted that:
 - There were no Underground Storage Tanks (UST's) on or near the site.
 - There were Underground Storage Tanks (UST's) on or near the site.
 - These UST's included those located at:
[Click or tap here to enter text.](#)
- The following Attachments have also been included:
 - Photographs
 - Website
 - Letter sent to Agency
 - Response received back from Agency

5. Endangered Species [50 CFR 402]

N/A

- Website
- Letter sent to Agency
- Response received back from Agency

6. Environmental Justice [Executive Order 12898]

- Is the proposed site located in or around a low-income or minority neighborhood?
 Yes No

The EPA, <https://www.epa.gov/ejscreen>, website tool was used. The following sites were identified on or near the site that may be a concern for the project

N/A

- Based on the above information, is the site located in a suitable, safe, and sanitary living environment?
 Yes No (Site should be rejected)

7. Explosive and Flammable Operations [24 CFR 51C]

- Visual review and pictures of site and surroundings conducted by [Ceylon Herath](#) on 08/04/2022.
 No known explosive or flammable operations were visible on or near the site.
 Explosive or flammable operations were visible on or near the site.
 - The site review identified the following concerns on or adjacent to the project site: There were no identifiable concerns on or adjacent to the project site.

8. Farmland Protection [7 CFR 658]

N/A

9. Floodplain Management [24 CFR 55, Executive Order 11988]

- Site is not located within a SFHA (100 year floodplain).
- The attached FEMA FIRM map was reviewed and indicates the site is not located in a Special Flood Hazard Area (SFHA). [\[See attached FIRM Map\]](#)
- Review DED's website for additional guidance within the related funding source manual.

10. Historic Preservation [36 CFR 800]

- The structure was built in the year: [N/A](#)
- A site review and photos of the property were completed on the following date: [N/A](#)
- Based on the review, it has been determined that the structure is:
 Historic
 Not historic
- It has also been determined that the rehab activities proposed in the project
 Will not impact any historic resources.
 May impact historic resources which may include the home or nearby houses or structures.

- A letter determining whether or not any historic resources might be impacted by the project, along with photos of the site, an aerial map of the residence, and a list of proposed activities were sent to the
 - SHPO on the following date: 07/14/2022
 - THPO on the following date: N/A
- SHPO response was received back on the following date: 08/12/2022
- SHPO noted **No adverse effect with conditions. Please see attached letter from SHPO.**
- THPO response was received back on the following date: N/A
- THPO noted N/A
- The following Attachments have also been included:

<input type="checkbox"/> Photographs	<input checked="" type="checkbox"/> Documentation showing SHPO was contacted
<input type="checkbox"/> Website	<input type="checkbox"/> Documentation showing THPO was contacted
<input type="checkbox"/> Maps	<input checked="" type="checkbox"/> Response received back from Nebraska SHPO
	<input type="checkbox"/> Aerials

11. Noise Control [24 CFR 51B]

- The proposed site is located within
 - _____ Feet of a busy/major roadway
 - _____ Feet of a railway
 - _____ Miles from a civil airport or military airfield
 - _____ Miles from any community airport
- Attach an aerial map(s), which includes the site marked, and map scale as documentation.
- Based on the above mentioned review, the proposed site is located within an acceptable noise environment, and no further evaluation is needed.
- Based on the above mentioned review, the proposed site is located within
 - 1,000 feet of a busy/major roadway
 - 3,000 feet of a railway
 - 15 miles from a civil airport or military airfield
- The site may be located within a normally unacceptable or unacceptable noise environment.
N/A
- A description of the noise attenuation measures that will be incorporated during the rehabilitation include:
N/A
- The comprehensive scope of weatherization improvements include:
N/A

13. Wetland Protection [24 CFR 55, Executive Order 11990]

N/A

14. Wild and Scenic Rivers [36 CFR 297]

58.6 Requirements, Flood Disaster Protection Act

Site is not located within a SFHA (100 year floodplain).

- The attached FEMA FIRM map _____ [Map #, Panel #] was reviewed and indicates the site is not located in a Special Flood Hazard Area (SFHA). [N/A]
- No FIRM map was available for the site. _____ was contacted on _____ and the attached information indicates the site is not located in a Special Flood Hazard Area (SFHA). [N/A]

Site is located within a SFHA (100 year floodplain).

- The attached FEMA FIRM map _____ [Map #, Panel #] was reviewed and indicates the site is located in a Special Flood Hazard Area (SFHA). [Attach the FIRM Map]
- No FIRM map was available for the site. _____ was contacted on _____ and the attached information indicates the site is located in a Special Flood Hazard Area (SFHA). [Attach source]
- Due to the location of the site, the property
 - Does not require the purchase of flood insurance
 - Requires the purchase of flood insurance. [Attach evidence the community is participating in the National Insurance Program and a copy of the flood insurance policy]

A site specific environmental review has been performed at the above location in compliance with HUD environmental review regulations (24 CFR 58) and related laws, authorities, and requirements. The review has been performed prior to the commitment of HUD or non-HUD funds, as required by 24 CFR 58.22(a) and (c).

This review shall be retained as a component of the project's ERR. Consult the Tier I for further information as to compliance with other laws and authorities for this HUD-assisted project.

Ceylon J. Herath

Preparer Name

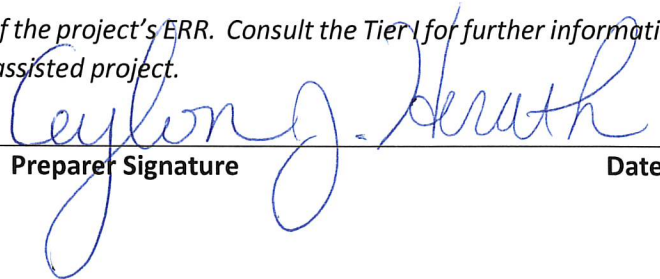
 8/15/22

Preparer Signature

Date

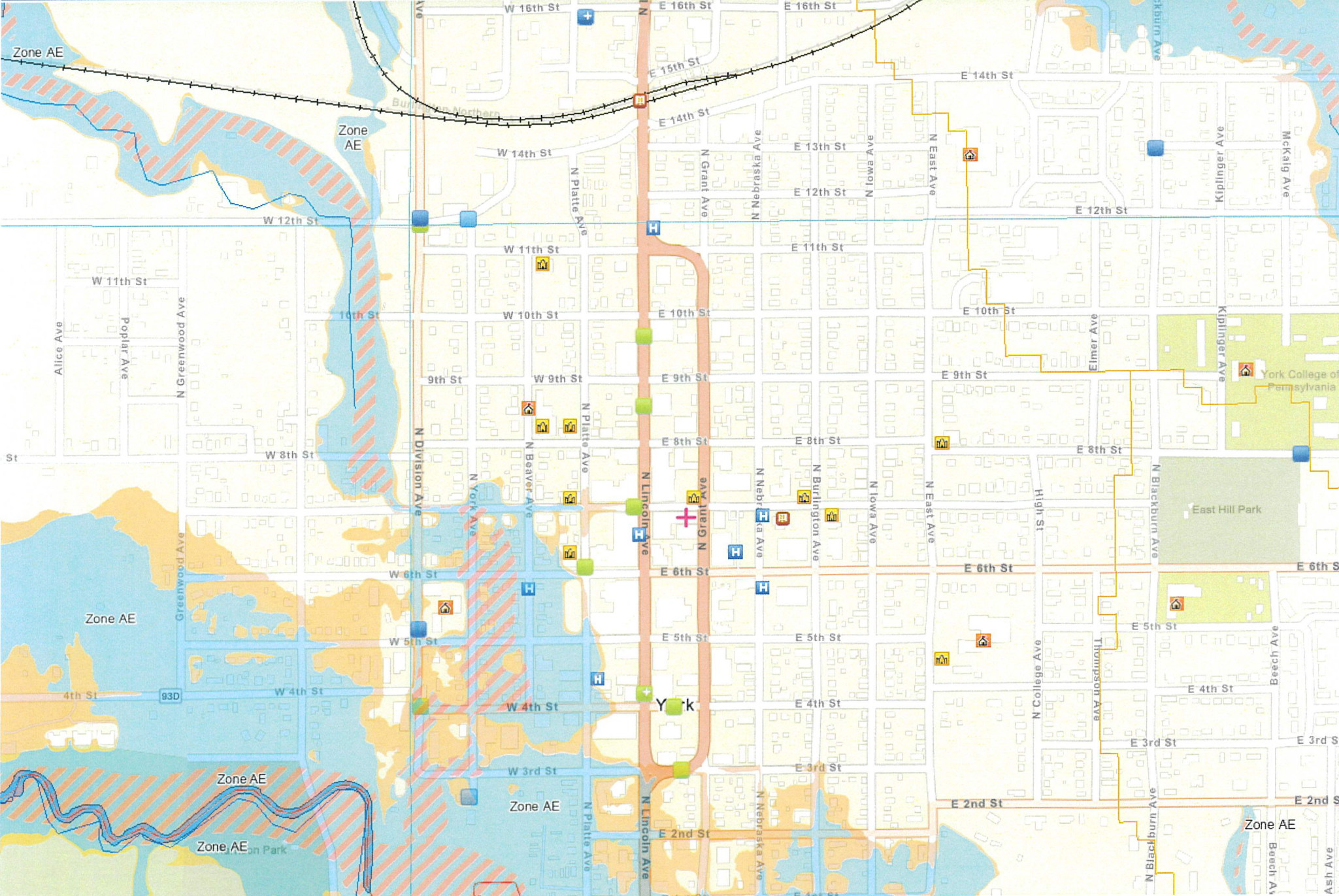



**History
NEBRASKA**
HISTORIC PRESERVATION

ONLINE SECTION 106 PROJECT FORM FOR
INDIVIDUAL STANDING STRUCTURES

History Nebraska

RECEIVED

NESHPO Use Only

Date Received
JUL 18 2022

HP Number

2207-033-01

Submission of a completed Project Information Form with adequate information and attachments constitutes a request for review pursuant to Section 106 of the National Historic Preservation Act of 1966 (as amended). More information may be required to complete the Section 106 process. Submit completed form to HN.HP@nebraska.gov.

NOTE: Section 106 regulations provide for a 30-day response time by the Nebraska State Historic Preservation Office from the date of receipt.

PROJECT NAME (if applicable)

York Downtown Revitalization Phase IV

COUNTY

York

STREET ADDRESS (No P.O. Box Numbers)

623 N. Grant Avenue

PROJECT NUMBER
(if applicable)

#21-DTR-014

CITY

York

FEDERAL AGENCY OR DESIGNEE

HUD-Community Development Block Grant (CDBG)/Southeast Nebraska Development District (SEND D)

CONTACT PERSON

Ceylon Herath

CITY, STATE ZIP

7407 O Street, Lincoln, NE 68510

TELEPHONE

4024752560

EMAIL (for response)

cherath@sendd.org

PROJECT DESCRIPTION

Briefly describe the overall project.

The project includes the following activities: Dose Management LLC in York, NE has applied for the City of York's Facade Improvement Program. Structural alterations for this project consist of:

Structural alterations: Painting a tuck point

DESIGNATIONS

To the best of your knowledge, is the structure any of the following?

- Listed Individually on the National Register
- Listed within a National Register Historic District
- Designated Local Landmark
- Designated Local Landmark District

PHOTOGRAPHS

Please provide photographs of all structures. Photographs of neighboring or nearby buildings are helpful. Go to page 2 to insert photo(s).

NESHPO USE ONLY

Nebraska SHPO Determination

Site Number: YK11-013

- No potential to cause effects
- Adverse effect (More consultation needed)
- No historic properties affected
- The SHPO requests additional information (see attached)

No adverse effect with conditions
(See letter)

Review & Compliance Coordinator
State Historic Preservation Office, Nebraska State Historical Society

Date 8/12/22

August 12, 2022

Ceylon Herath
Community Development Specialist
SEND
VIA EMAIL

RE: HP# 2207-033-01 YK11-013, 623 N Grant Ave, Painting and Tuck Pointing, York, York County, NE

Dear Ceylon Herath,

Thank you for submitting the referenced project proposal for our review and comment. Our comment on this project and its potential to affect historic properties is required by Section 106 of the National Historic Preservation Act of 1966, as amended, and implementing regulations 36 CFR Part 800.

According to the information you have provided, there will be **no adverse effect** resulting from this project, provided that the following **conditions** are met:

1. Brick Painting: Only brick previously painted should be painted.
2. Power Washing: Due to the material make-up of Nebraska brick, when a power wash is used its pressure setting should not be set higher than 300psi. A higher pressure sets puts the brick at risk of being damaged.
3. Tuck-Pointing: Hand tools should be used. All efforts should be taken to ensure that the mortar used is similar in color and texture to the existing building mortar. New and repaired joints should have the same profile as historic and existing joints. If any brick needs to be repaired, brick similar in color, texture, and size to the original historic brick should be used.

Should any changes in the project be made or in the type of funding or assistance provided through federal or state agencies, please notify this office of the changes before further project planning continues. Please retain this correspondence and your documented finding in order to show compliance with Section 106 of the National Historic Preservation Act, as amended. If you have any questions, please contact me at Betty.Gillespie@nebraska.gov or 402-805-7392.

Sincerely,

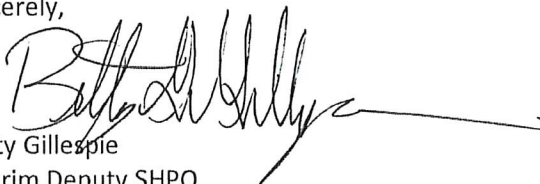

Betty Gillespie
Interim Deputy SHPO
Section 106 Review and Compliance Coordinator
History Nebraska

1500 R Street
Lincoln, NE 68508-1651
P: 402.471.3270
history.nebraska.gov

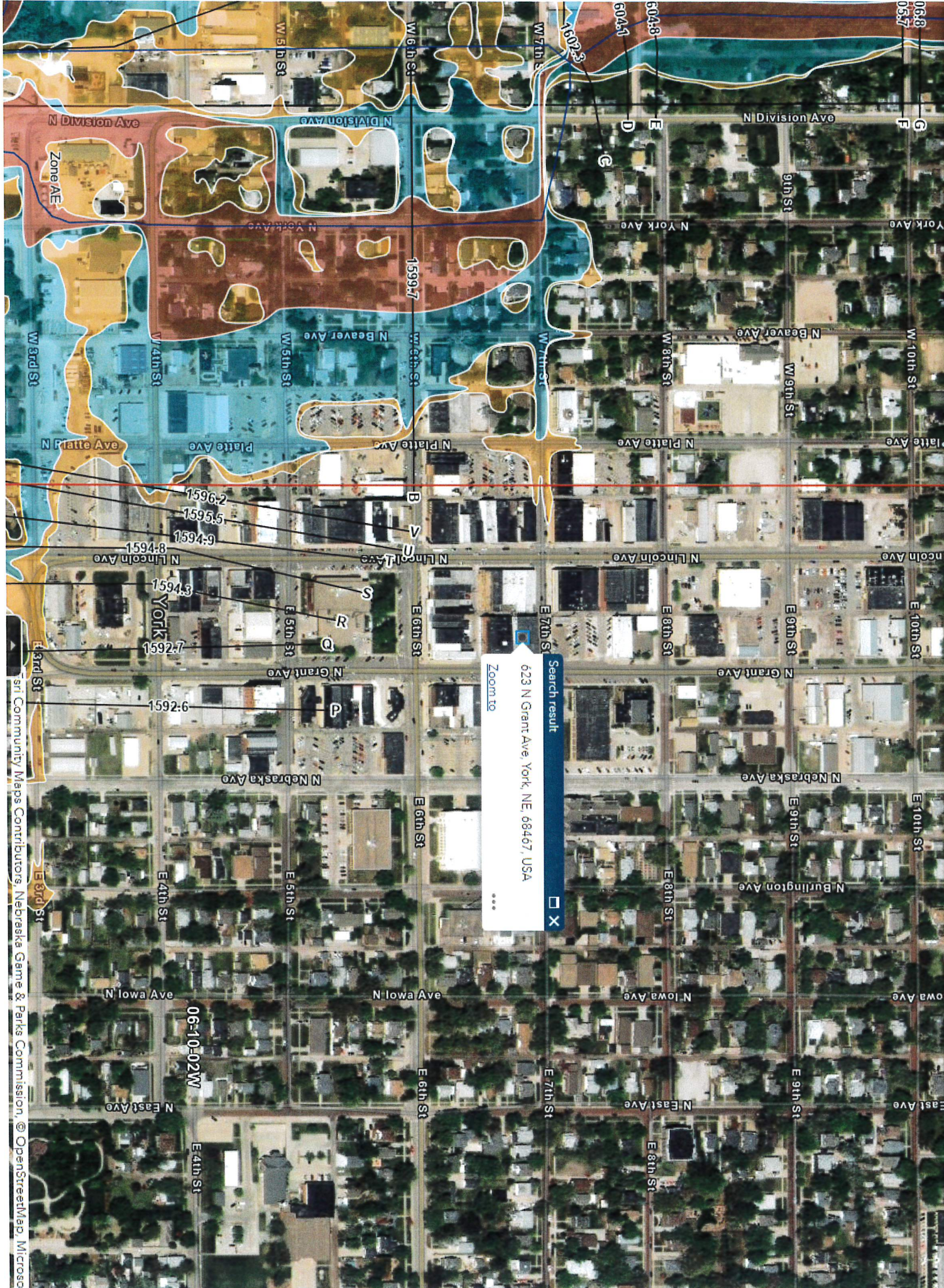



Administrative Offices
P.O. Box 276
100 E. 4th Street
York, NE 68467

York Facade Improvement Program Application

Applicant Name: Cris Slack
Applicant's Phone Number: 402-362-7708
Applicant's Email Address: crisslack@hotmail.com
Business Name: Slack Auto Supply, LLC - DBA Carquest Auto Parts
Property Owner: Cris Slack
Property Address: 817 N Lincoln Ave
Property Legal Description: _____

Type of façade improvement planned (see Design Guidelines)

Restoration Renovation Replacement Reconstruction

Structural alterations: Replace outdoor sign and electrical to support new sign

Cosmetic alterations (i.e. moldings): _____

Painting (approximate sq. ft. area): _____

Interior Improvements: _____

Specify other work (i.e. awnings): _____

Total cost of project: \$23,850.00

DTR Project Funds Amount requested: \$ 17,887.50

I hereby submit the attached plans, specifications and color samples for the proposed project, and understand that these must be approved by the City of York. No work may begin until I have received

written notice to proceed from the City of York. I further understand that the project must be completed by November 20, 2023. Grant funds will not be paid until the project is commenced. If the City has not received correspondence in that time frame, the funds will be reallocated. I agree to leave the completed project in its approved design and colors for a period of five (5) years from the date of completion. If changed before the end of five (5) years, I agree to pay back the funded amount.

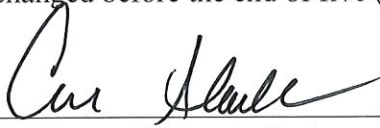

Signature of Property Owner

Cris Slack

Printed Name & Title of Property Owner

5/3/2022

Date

Signature of Business Owner (if applicable)

Printed Name & Title of Business Owner

Date

Applications to be sent to:

DTR Committee
603 N Lincoln Ave
York, NE 68467

Release and Hold Harmless Agreement

Release executed on this 3 day of May, 2022,
by (Property Owner) Cris Slack and
(Business owner if applicable) _____, of
(Street Address) 817 N Lincoln Ave, City of York, State of
Nebraska, referred to as Releaser(s).

In consideration of being granted monies for restoration, modifications, or other physical changes to the property located at the above address, the Releaser(s), understands that they are solely responsible for providing their own contractors, paying their contractors, to assure that those contractors are fully insured and licensed, and have obtained all necessary permits in accordance with all pertinent regulations. The Releaser(s) waives, releases, discharges, and agrees to indemnify the City of York (or entities under the City's umbrella), for loss or damage, and claims or damages therefore, on account of any work that has been performed in accordance with City or State guidelines.

Releaser(s) agrees that this release, waiver, and indemnity agreement is intended to be as broad and inclusive as permitted by the laws of the State of Nebraska and that if any portion of the agreement is held invalid, it is agreed that the balance shall; notwithstanding, continue in full legal force and effect.

Releaser's obligation and duties hereunder shall in no manner be limited or restricted by the maintaining of any insurance coverage related to the above referenced event.

This release contains the entire agreement between the parties to this agreement and the terms of this release are contractual and are not a mere recital.

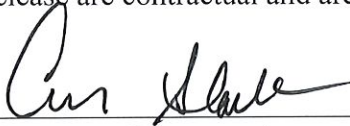

Signature of Property Owner

Cris Slack

Printed Name & Title of Property Owner

5/3/2022

Date

Signature of Business owner (if applicable)

Printed Name & Title of Business Owner

Date

Due Diligence Worksheet

Contractor Business Name: Sign Project - not able to locate another vendor that can complete scope of project

Contractor Business Address: _____

Contact Name: _____

Phone Number: _____

Email Address: _____

Scope of Work for Bidding: Create/Install new electronic signage

Method used to reach out to Contractor (check all that apply/attach copies if applicable)

Date: _____ Phone _____ Text _____ Email _____ Letter _____

Date: _____ Phone _____ Text _____ Email _____ Letter _____

Project Property Owner Printed Name: CRIS Slack

Project Property Owner Signature: Cris Slack

Address of Project Property: 817 N LINCOLN AVE

Date: 8/5/3/2022



MANUFACTURING AGREEMENT

3030 W. OLD HWY. 30
 GRAND ISLAND, NE 68803
 P.O. BOX 5791
 GRAND ISLAND, NE 68802
 PHONE: 308-381-5525
 FAX: 308-381-5528
 TOLL FREE: 877-381-5530

In Agreement With	Phone	Date
<u>Slack Auto Supply</u>	<u>N/A</u>	<u>5/3/21</u>
Street	Job Name	
<u>817 North Lincoln Ave</u>	<u>Same</u>	
City, State and Zip Code	Job Location	
<u>York, NE 68467</u>	<u>Same</u>	
Architect	Date of Plans	Job Phone

Love Signs of Grand Island, L.L.C., by its acceptance, hereof agrees to furnish the following work hereafter and on page two referred to as the Display System and according to the print attached hereto and made a part of this agreement.

Option 3: 10mm Color LED Display

Install single sided 3'-5" x 7'-3" 10mm Watchfire Color LED Message Display. 90 x 210 pixel matrix can display detailed color images, text and video. Content to be designed in supplied Ignite software to be installed on customer supplied computer. Radio communication. Install on existing structure by removing existing Carquest cabinet. Includes online training with Watchfire. Final electrical by others.

PRICE: \$21,571.00

All signs are custom built products and, at the option of seller, require payment in advance with order. Installation price is due upon installation. 50% due upon acceptance and the balance due upon installation. 2% discount if paid in full upon acceptance. Contract prices are guaranteed for 60 days and may be subject to change after that time.

This contract, with all conditions as noted, is herewith accepted by both parties.

<u>Derek Beck</u> Sales Representative	<u>Cris Slack</u> Purchaser
Love Signs of Grand Island, L.L.C.	By _____
By _____	Title _____
Title _____	Guaranteed By _____
	Acceptance Date _____



MANUFACTURING AGREEMENT

3030 W. OLD HWY. 30
 GRAND ISLAND, NE 68803
 P.O. BOX 5791
 GRAND ISLAND, NE 68802
 PHONE: 308-381-5525
 FAX: 308-381-5528
 TOLL FREE: 877-381-5530

In Agreement With Slack Auto Supply	Phone N/A	Date 2/2/21
Street 817 North Lincoln Ave	Job Name Same	
City, State and Zip Code York, NE 68467	Job Location Same	
Architect	Date of Plans	Job Phone

Fabricate and install (1) single face 4' x 16' non-illuminated Wall Sign. Use Blue Dibond and die cut vinyl to match drawing. Apply vinyl first surface. Install using angle stringers on the backside.
PRICE: \$1,050.00

PAGE 2 of 2

All signs are custom built products and, at the option of seller, require payment in advance with order. Installation price is due upon installation. 50% due upon acceptance and the balance due upon installation. 2% discount if paid in full upon acceptance. Contract prices are guaranteed for 60 days and may be subject to change after that time.

This contract, with all conditions as noted, is herewith accepted by both parties.

Derek Beck Sales Representative	Cris Slack Purchaser
Love Signs of Grand Island, L.L.C.	By _____
By _____	Title _____
Title _____	Guaranteed By _____
	Acceptance Date _____



Tier II: Site Specific Environmental Review

Community Development Block Grant

Grant Number: #21-DTR-014

Grantee: Slack Auto Supply, LLC (Carquest Auto Parts)

Property Address 817 N. Lincoln Avenue, York, NE 68467

Activity Description

The project includes the following activities: Slack Auto Supply, LLC – DBA Carquest Auto Parts has applied for the City of York’s Façade Improvement Program. Replacement activities for this project consist of:

Structural alterations: Replace outdoor signage and run electricity to support new signage

Cost:

- Projected Acquisition Cost **\$0.00**
- Projected Rehab Cost **\$23, 850.00**
- Projected All Cost **\$23, 850.00**

1. Air Quality [Clean Air Act sections 176(c) & (d), and 40 CFR 6, 51, 93] Steps used to address Radon must match rehab process as outlined in the program guidelines.

N/A

2. Airport Hazards [24 CFR 51D] Also provide a map showing the direct line distance between airport and each housing unit proposed for assistance.

N/A

4. Contamination and Toxic Substances [24 CFR 58.5(i)(2)]

- Visual review and pictures of site and surroundings conducted by [Ceylon Herath](#) on 08/04/2022
- The site review identified the following concerns on or adjacent to the project site:
[According to the site review, there are no concerns on or adjacent to the project site.](#)
- The EPA, <https://www.epa.gov/nepa/nepassist>, mapping web-tool was used. The following sites were identified on or near the site that may be a concern for the project
[There are no sites on or near the project site that may be a concern for the project.](#)
- The DEQ, <http://deqims2.deq.state.ne.us/deqflex/DEQ.html>, mapping web-tool was used. The following sites were identified on or near the site that may be a concern for the project
N/A
- The Fire Marshall was sent a letter on 08/04/2022 and is not attached.
- The Agency response letter noted that:
 - There were no Underground Storage Tanks (UST’s) on or near the site.
 - There were Underground Storage Tanks (UST’s) on or near the site.
 - These UST’s included those located at:
[Click or tap here to enter text.](#)
- The following Attachments have also been included:
 - Photographs
 - Website

- Letter sent to Agency
- Response received back from Agency

- Maps
- Aerials

5. Endangered Species [50 CFR 402]

N/A

- Website
- Letter sent to Agency
- Response received back from Agency

6. Environmental Justice [Executive Order 12898]

- Is the proposed site located in or around a low-income or minority neighborhood?
 Yes No

The EPA, <https://www.epa.gov/ejscreen>, website tool was used. The following sites were identified on or near the site that may be a concern for the project

N/A

- Based on the above information, is the site located in a suitable, safe, and sanitary living environment?
 Yes No (Site should be rejected)

7. Explosive and Flammable Operations [24 CFR 51C]

- Visual review and pictures of site and surroundings conducted by [Ceylon Herath](#) on 08/04/2022.
 No known explosive or flammable operations were visible on or near the site.
 Explosive or flammable operations were visible on or near the site.
 - The site review identified the following concerns on or adjacent to the project site: There were no identifiable concerns on or adjacent to the project site.

8. Farmland Protection [7 CFR 658]

N/A

9. Floodplain Management [24 CFR 55, Executive Order 11988]

- Site is not located within a SFHA (100 year floodplain).
- The attached FEMA FIRM map was reviewed and indicates the site is not located in a Special Flood Hazard Area (SFHA). [\[See attached FIRM Map\]](#)
- Review DED's website for additional guidance within the related funding source manual.

10. Historic Preservation [36 CFR 800]

- The structure was built in the year: N/A
- A site review and photos of the property were completed on the following date: N/A
- Based on the review, it has been determined that the structure is:
 - Historic
 - Not historic
- It has also been determined that the rehab activities proposed in the project
 - Will not impact any historic resources.

- May impact historic resources which may include the home or nearby houses or structures.
- A letter determining whether or not any historic resources might be impacted by the project, along with photos of the site, an aerial map of the residence, and a list of proposed activities were sent to the
 - SHPO on the following date: 07/14/2022
 - THPO on the following date: N/A
- SHPO response was received back on the following date: 07/18/2022
- SHPO noted No historic properties affected.
- THPO response was received back on the following date: N/A
- THPO noted N/A
- The following Attachments have also been included:

<input type="checkbox"/> Photographs	<input checked="" type="checkbox"/> Documentation showing SHPO was contacted
<input type="checkbox"/> Website	<input type="checkbox"/> Documentation showing THPO was contacted
<input type="checkbox"/> Maps	<input checked="" type="checkbox"/> Response received back from Nebraska SHPO
	<input type="checkbox"/> Aerials

11. Noise Control [24 CFR 51B]

- The proposed site is located within
 - _____ Feet of a busy/major roadway
 - _____ Feet of a railway
 - _____ Miles from a civil airport or military airfield
 - _____ Miles from any community airport
- Attach an aerial map(s), which includes the site marked, and map scale as documentation.
- Based on the above mentioned review, the proposed site is located within an acceptable noise environment, and no further evaluation is needed.
- Based on the above mentioned review, the proposed site is located within
 - 1,000 feet of a busy/major roadway
 - 3,000 feet of a railway
 - 15 miles from a civil airport or military airfield
- The site may be located within a normally unacceptable or unacceptable noise environment.
N/A
- A description of the noise attenuation measures that will be incorporated during the rehabilitation include:
N/A
- The comprehensive scope of weatherization improvements include:
N/A

13. Wetland Protection [24 CFR 55, Executive Order 11990]

N/A

14. Wild and Scenic Rivers [36 CFR 297]

N/A

58.6 Requirements, Flood Disaster Protection Act

Site is not located within a SFHA (100 year floodplain).

- The attached FEMA FIRM map _____ [Map #, Panel #] was reviewed and indicates the site is not located in a Special Flood Hazard Area (SFHA). [N/A]
- No FIRM map was available for the site. _____ was contacted on _____ and the attached information indicates the site is not located in a Special Flood Hazard Area (SFHA). [N/A]

Site is located within a SFHA (100 year floodplain).

- The attached FEMA FIRM map _____ [Map #, Panel #] was reviewed and indicates the site is located in a Special Flood Hazard Area (SFHA). [Attach the FIRM Map]
- No FIRM map was available for the site. _____ was contacted on _____ and the attached information indicates the site is located in a Special Flood Hazard Area (SFHA). [Attach source]
- Due to the location of the site, the property
 - Does not require the purchase of flood insurance
 - Requires the purchase of flood insurance. [Attach evidence the community is participating in the National Insurance Program and a copy of the flood insurance policy]

A site specific environmental review has been performed at the above location in compliance with HUD environmental review regulations (24 CFR 58) and related laws, authorities, and requirements. The review has been performed prior to the commitment of HUD or non-HUD funds, as required by 24 CFR 58.22(a) and (c).

This review shall be retained as a component of the project's ERR. Consult the Tier I for further information as to compliance with other laws and authorities for this HUD-assisted project.

Ceylon J. Herath

Preparer Name

Ceylon J. Herath 8/8/22

Preparer Signature

Date

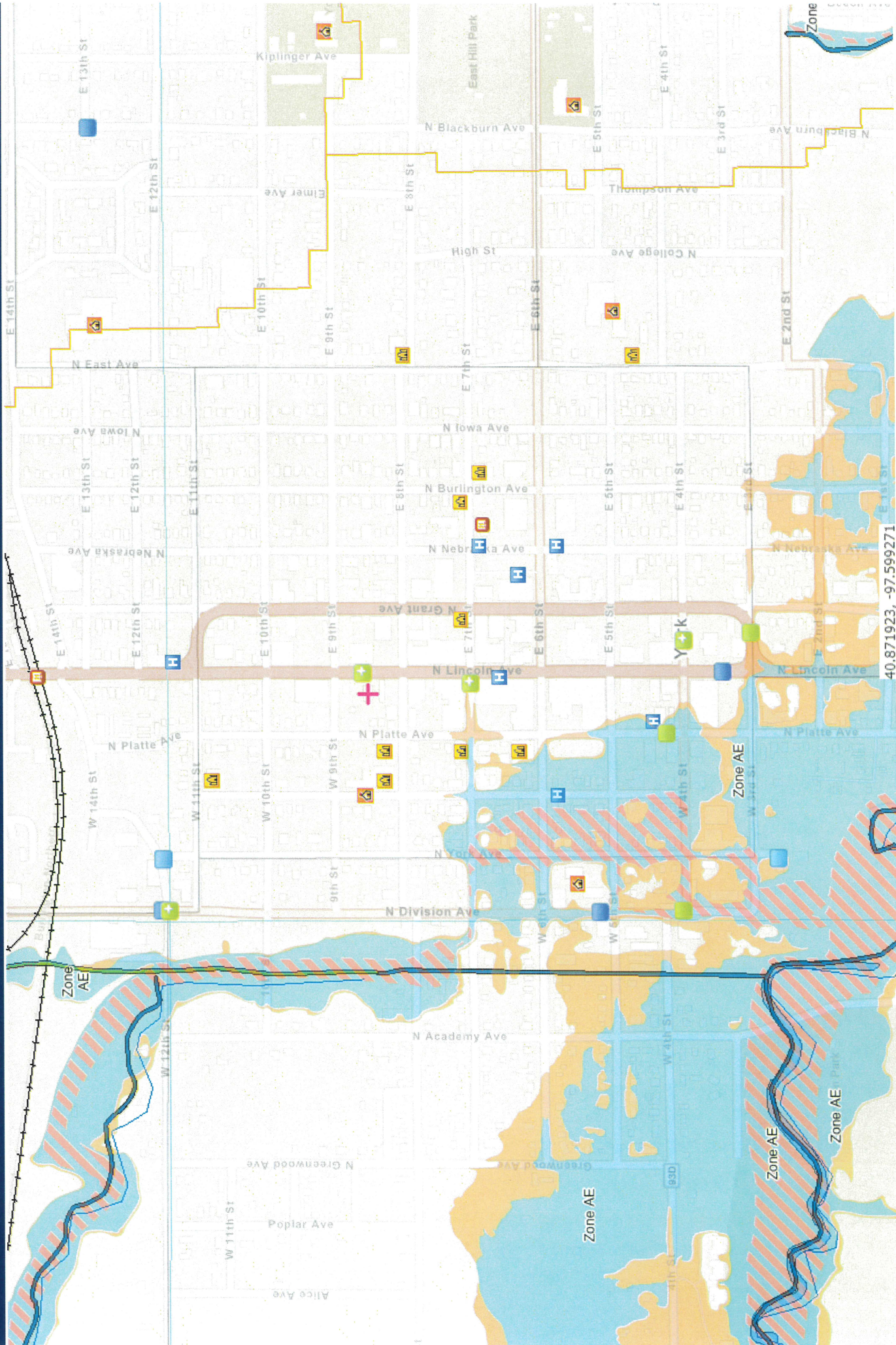



History
NEBRASKA
HISTORIC PRESERVATION

ONLINE SECTION 106 PROJECT FORM FOR
INDIVIDUAL STANDING STRUCTURES

History Nebraska

NESHPO Use Only

Date Received

HP Number

JUL 18 2022

2207-034-01

Submission of a completed Project Information Form with adequate information and attachments constitutes a request for review pursuant to Section 106 of the National Historic Preservation Act of 1966 (as amended). More information may be required to adequately complete the Section 106 process. Submit completed form to HN.HP@nebraska.gov.

NOTE: Section 106 regulations provide for a 30-day response time by the Nebraska State Historic Preservation Office from the date of receipt.

PROJECT NAME (if applicable)

York Downtown Revitalization Phase IV

COUNTY

York

STREET ADDRESS (No P.O. Box Numbers)

817 N. Lincoln Avenue

PROJECT NUMBER

(if applicable)

#21-DTR-014

CITY

York

FEDERAL AGENCY OR DESIGNEE

HUD-Community Development Block Grant (CDBG)/Southeast Nebraska Development District (SEND) (SEND)

CONTACT PERSON

Ceylon Herath

CITY, STATE ZIP

7407 O Street, Lincoln, NE 68510

TELEPHONE

4024752560

EMAIL (for response)

cherath@sendd.org

PROJECT DESCRIPTION

Briefly describe the overall project.

The project includes the following activities: Slack Auto Supply, LLC - DBA CarQuest Auto Parts has applied for the City of York's Facade Improvement Program. Replacement activities for this project consist of:

Structural alterations: Replace outdoor signage and run electricity to support new signage

DESIGNATIONS

To the best of your knowledge, is the structure any of the following?

- Listed Individually on the National Register
- Listed within a National Register Historic District
- Designated Local Landmark
- Designated Local Landmark District

PHOTOGRAPHS

Please provide photographs of all structures. Photographs of neighboring or nearby buildings are helpful. Go to page 2 to insert photo(s).

NESHPO USE ONLY

Nebraska SHPO Determination

Site Number: _____

- No potential to cause effects
- No historic properties affected
- No adverse effect
- Adverse effect (More consultation needed)
- The SHPO requests additional information (see attached)

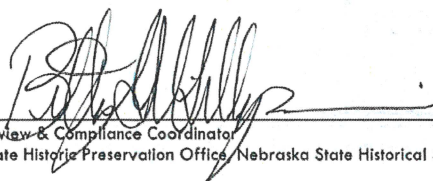

Review & Compliance Coordinator
State Historic Preservation Office, Nebraska State Historical Society

Date 7/19/22

Management Interactive Map

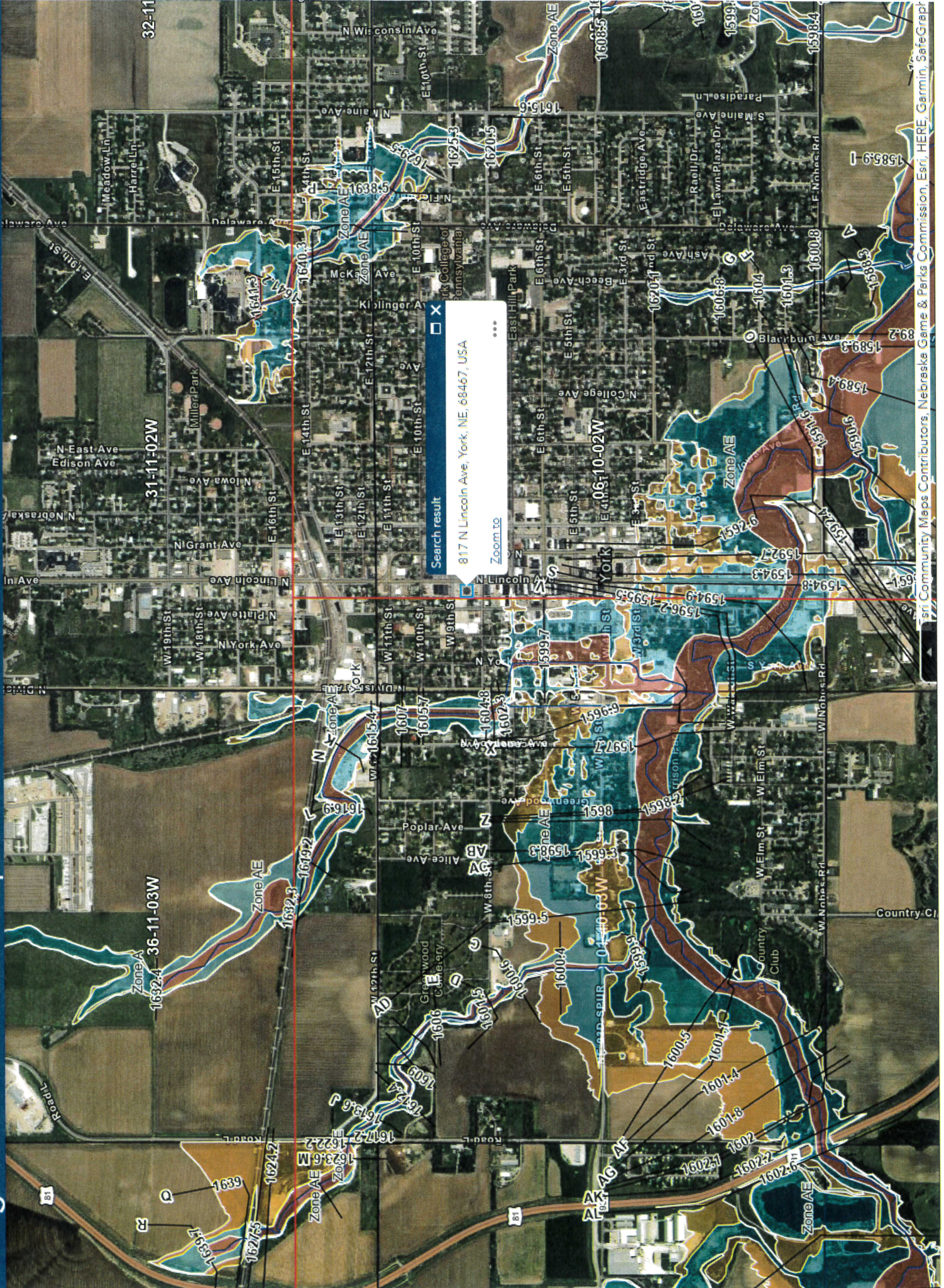

ORDINANCE NO. 2331

AN ORDINANCE TO PROVIDE FOR THE ANNEXATION OF LAND AND TO PROVIDE AN EFFECTIVE DATE FOR THIS ORDINANCE.

BE IT ORDAINED BY THE MAYOR AND CITY COUNCIL OF THE CITY OF YORK, NEBRASKA:

Section 1. Annexation Ordinance.

Pursuant to Neb. Rev. Stat. §16-117 (Reissue 2012), a Petition has been filed by the owners of property contiguous or adjacent to the City to request that said property be included within the corporate limits of the City of York. The Petition recites that Chris Grant and Aislee Grant are the owners of real estate described below which is urban or suburban in character:

Lots 7, 8, 9, 10, 11, 12, 13 in Countryside View Second Subdivision, a part of the Southeast Quarter of the Southeast Quarter of Section 24, Township 10 North, Range 3 West of the 6th P.M., in York County, Nebraska.

Section 2. After notice pursuant to law the City Council adopts this Ordinance to approve the Petition and the annexation of the real estate described above, and the Council hereby authorizes the annexation of such real estate to the corporate limits of the City of York, Nebraska, which property is contiguous or adjacent to the corporate limits of the City and which is urban or suburban in character.

Section 3. This Ordinance shall be in full force and effect from its passage, approval and publication as required by law.

PASSED AND APPROVED by the York City Council this _____ day of August, 2022.

Barry Redfern, Mayor

ATTEST:

Amanda Ring, York City Clerk

ORDINANCE NO. 2334

AN ORDINANCE TO AMEND PORTIONS OF CHAPTER 37 OF THE MUNICIPAL CODE OF THE CITY OF YORK, NEBRASKA, PRESCRIBING SEWER RATES, REPEAL OF ALL ORDINANCES IN CONFLICT HEREWITH, AND PROVIDING FOR THE EFFECTIVE DATE OF SAID ORDINANCE.

BE IT ORDAINED BY THE MAYOR AND COUNCIL OF THE CITY OF YORK, NEBRASKA:

Section 1.

Sec. 37-91 Schedule of Rates (Commercial and Residential)

- (a) Usage Charge per 100 cubic feet \$2.12
- Usage Charge over 1,000,000 cubic feet \$2.57
- (b) The bi-monthly rates to be charged to users shall be determined by meter size, as follows:
- | | |
|-----------------------|------------|
| Minimum per household | \$55.50 |
| 5/8 and 3/4 inch | \$55.50 |
| 1 inch | \$89.14 |
| 1 ½ inch | \$232.62 |
| 2 inch | \$394.25 |
| 3 inch | \$805.08 |
| 4 inch | \$1,489.30 |
| 6 inch | \$2,904.59 |

The balance of said section to remain unchanged.

Section 2. All ordinances and parts of ordinances in conflict herewith are hereby repealed.

Section 3. This ordinance shall take effect and be in full force and effect from and after its passage, approval and publication pursuant to law.

PASSED AND APPROVED by the York City Council this 1st day of September, 2022.

Barry Redfern, Mayor

ATTEST:

Amanda Ring, York City Clerk

Do not recreate or revise the pages of this document, as revisions and recreations will not be accepted. Failure to return both pages of the original document by the filing deadline (October 31, 2022) may result in the suspension of Highway Allocation funds until the documents are filed.

RESOLUTION

**SIGNING OF THE
MUNICIPAL ANNUAL CERTIFICATION OF PROGRAM COMPLIANCE
2022**

Resolution No. 2022-16

Whereas: State of Nebraska Statutes, sections 39-2115, 39-2119, 39-2120, 39-2121, and 39-2520(2), requires an annual certification of program compliance to the Nebraska Board of Public Roads Classifications and Standards; and

Whereas: State of Nebraska Statute, section 39-2120 also requires that the annual certification of program compliance by each municipality shall be signed by the Mayor or Village Board Chairperson and shall include the resolution of the governing body of the municipality authorizing the signing of the certification.

Be it resolved that the Mayor Village Board Chairperson of City of York
(Check one box) (Print name of municipality)
is hereby authorized to sign the Municipal Annual Certification of Program Compliance.

Adopted this _____ day of _____, 2022 at York Nebraska.
(Month)

City Council/Village Board Members

City Council/Village Board Member _____
Moved the adoption of said resolution
Member _____ Seconded the Motion
Roll Call: _____ Yes _____ No _____ Abstained _____ Absent
Resolution adopted, signed and billed as adopted.

Attest:

(Signature of Clerk)

Do not recreate or revise the pages of this document, as revisions and recreations will not be accepted. Failure to **return both pages of the original document** by the filing deadline (October 31, 2022) may result in the suspension of Highway Allocation funds until the documents are filed.

MUNICIPAL ANNUAL CERTIFICATION OF PROGRAM COMPLIANCE TO NEBRASKA BOARD OF PUBLIC ROADS CLASSIFICATIONS AND STANDARDS 2022

In compliance with the provisions of the State of Nebraska Statutes, sections 39-2115, 39-2119, 39-2120, 39-2121, and 39-2520(2), requiring annual certification of program compliance to the Board of Public Roads

Classifications and Standards, the City Village of York
(Check one box) (Print name of municipality)

hereby certifies that it:

- ✓ has developed, adopted, and included in its public records the plans, programs, or standards required by sections 39-2115 and 39-2119;
- ✓ meets the plans, programs, or standards of design, construction, and maintenance for its highways, roads, or streets;
- ✓ expends all tax revenue for highway, road, or street purposes in accordance with approved plans, programs, or standards, including county and municipal tax revenue as well as highway-user revenue allocations;
- ✓ uses a system of revenue and costs accounting which clearly includes a comparison of receipts and expenditures for approved budgets, plans, programs, and standards;
- ✓ uses a system of budgeting which reflects uses and sources of funds in terms of plans, programs, or standards and accomplishments;
- ✓ uses an accounting system including an inventory of machinery, equipment, and supplies;
- ✓ uses an accounting system that tracks equipment operation costs;
- ✓ has included in its public records the information required under subsection (2) of section 39-2520; and
- ✓ **has included in its public records a copy of this certification and the resolution of the governing body authorizing the signing of this certification by the Mayor or Village Board Chairperson.**



Signature of Mayor Village Board Chairperson (Required) (Date)

Signature of City Street Superintendent (Optional) (Date)

Return the completed original signing resolution and annual certification of program compliance by October 31, 2022 to:

Nebraska Board of Public Roads Classifications and Standards
PO Box 94759
Lincoln NE 68509

York City Council

I am contacting you all about York's current Food Truck regulations. York's current policy allows for Food Trucks to operate only on private property. This policy is not a problem if you know a local business owner but problematic for those who come from other towns or states. In my experience, most business owners are hesitant to allow a stranger to set up on their property without some sort of relation (a friend of a friend, a family friend, etc). Some are also hesitant because if they let one food truck set up they feel pressure to let all food trucks set up so they may write it off completely. York has 8 downtown parking lots and at least 4 parking lots near public parks. While these lots are always occupied, they are not completely full. The council could limit this to these parking lots or be as open as allowing operation around the courthouse square with other regulations. I found some examples off communities that allow operation in City limits with a permit; Central City, Aurora and Ainsworth allow operation in City limits with a permit.

By creating a permit process to operate on public ground, York would make headway on local community goals; creating a livelier downtown, create better access to food, and allow for more "non-interstate" food options. York currently has 8 options to eat that are not located at the interstate; Seward has 12, Aurora has 9, Beatrice has 17, and Geneva has 5. In my opinion, more people would frequent the downtown area if there were more food options; food brings us together. Restaurants are hard to start and food trucks are growing more and more popular so to allow food trucks operation in the downtown would create a livelier downtown environment. Access to food has been a conversation for a number of groups in York and I believe this could help with that problem. Food trucks typically have fresher food options and typically have their ingredients sourced from local suppliers. With less than 2 "non-interstate" restaurants offering a meal before 10am and less than 2 "non-interstate" options offering a meal after 10pm, York does not have many options that dont require a 15-20 minute drive. Add to that a growing shift workforce and you are limited to food options if you dont work the typical 9-5 day.

In summary, I encourage the York City Council to consider adopting a policy to allow food trucks to operate with a permit on public property. I also think limitations should be considered like the locations where food trucks will be limited to, times of operation that food trucks must operate by as well as local inspections on top of the the regulatory inspections that are required to operate. Thank you for considering this.

Derek Dauel

Fee:

CITY OF YORK, NEBRASKA
APPLICATION FOR MOVERS PERMIT

Applicant: Brandon Skilton

Owner of Building: Steve Klute

Building Description to be moved: Size 29' x 56'; 2 Story

Present Location of Building to be moved: 715 W. 4th St. X

Building being Relocated to: 10th and Greenwood

Route: Across 4th St down Greenwood to
Work to 10th and Greenwood

Date Moved: Sept 5th

It is understood that an approved Building Permit is on file and that the City Council has duly approved the location to which the Building is to be moved.

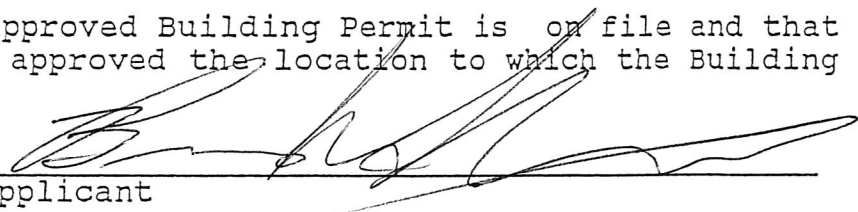
Applicant

MOVERS PERMIT

This permit is the lawful authority of _____
_____ (applicant) to move a building and/or

structure to: 1007 N Greenwood, York NE

in accordance with the terms of the above Application and in strict compliance with the ordinances of the City of York and the State of Nebraska.

Dated this _____ day of _____, 19__.

City Clerk



Administrative Offices
P.O. Box 276
100 E. 4th Street
York, NE 68467

August 16, 2022

This house is sitting at 715 W 4th Street, York, Nebraska. The house is well maintained and is approximately 100 years old. The electrical, plumbing and HVAC have had some updates. The basement joists are solid and Show no signs of decay. The house does have the original wood siding and appears in good shape. It has a Newer roof and will need some hail damaged windows replaced on the west side. Over all the house is in good shape and should make a good home. The owner is looking to move the house to an empty lot at 1007 N Greenwood. Upon approval the house is scheduled to be move about September 5, 2022.

**Dan Aude
Building Inspector**



APPLICATION FOR BUILDING PERMIT

FEE \$ 244-bill
Plumbing
Electrical
Mechanical

Address 1007 N. Greenwood
York, Nebraska Date 8-5-22

- Alter, Construct, Enlarge, Re-Roof, Re-Side, Agricultural, Institutional, Commercial, Industrial, Residential, SF, MF No. of Units

Legal Description:
Proposed Work/Intended Use: Primary Residence

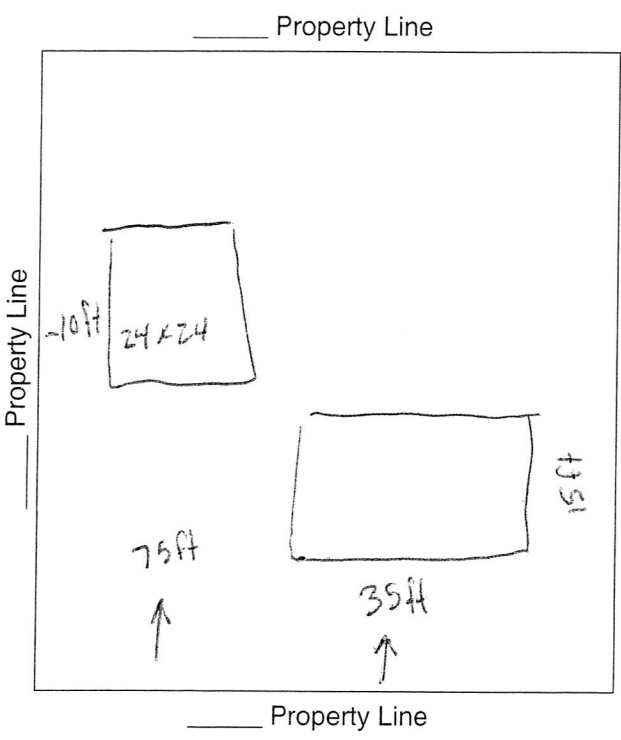

NEW CONSTRUCTION

Size 29 x 56 = 1624 sq. ft.
Height ft. No. of Stories 2
Type of Construction
1st Flr. sq. ft. @ = \$
Add'l. Flr. sq. ft. @ = \$
Basement 1624 sq. ft. @ = \$
Carport sq. ft. @ = \$
Garage 576 sq. ft. @ = \$
Accessory
Bldg. sq. ft. @ = \$
Air Cond. sq. ft. @ = \$
Sprin. Sys. sq. ft. @ = \$

REMODEL / RE-ROOF / RE-SIDE

Plumbing & Heating Cost \$ 2800.00
Electrical Cost \$ 1000.00
Mechanical Cost \$ 74,500 71,000
General Contract Cost \$

TOTAL CONSTRUCTION VALUE \$ 74,500

Indicating front property line, show new or existing buildings and additions to property above in addition to plot plan submitted with drawing.

Zone R Flood Zone NO
Special Use Permit
Variance Required

Owner Brandon Skelton
Architect or Engineer
Contractor or Builder

Approved Council/Board of Adjustment Date
Approved Director of Public Works Date

I hereby certify that the above statements are correct and that if a Building Permit is issued all work will be done in accordance with adopted Codes, copies of which are available from the York City Clerk.
Applicant



Parcel Information	
Parcel ID	930035984
Links	Photo #1 Photo #2 Sketch #1
Area #	
Current Owner	KLUTE/STEVEN W & KIMM LU
Mailing Address	PO BOX 66 BRADSHAW, NE 68319-0000
Situs Address	715 W 4TH ST
Tax District	5
School District	215 (SD#12 YORK)
Legal Description	LOT 1 LAGE'S SUB 1-10-3 CITY OF YORK
Class	Single Family

Current Value Information			
Land Value	Dwelling Value	Improvement Value	Total Value
\$15,405	\$71,940	\$0	\$87,345

Prior Year Value Information				
Year	Land Value	Dwelling Value	Improvement Value	Total Value
2021	\$15,405	\$70,529	\$0	\$85,934
2020	\$15,405	\$70,529	\$0	\$85,934
2019	\$15,405	\$62,082	\$0	\$77,487
2018	\$15,405	\$62,082	\$0	\$77,487
2017	\$15,120	\$61,095	\$0	\$76,215

Yearly Tax Information			
Year	Amount	Improvement	Levy
2021	\$1,533.36	\$0.00	1.891888

Sales Information					
Sale Date	Sale Price	Book & Page	Seller	Buyer	Other Parcels
03/15/2022	\$232,500.00	109 / 769	LAGE/NIKI	KLUTE/STEVEN W & KIMM LU	

Residential Building Information			
Occupancy Code	102 (Single-Family / Rental Unit)	Condition Code	Normal
Year Built	1920	Rooms Above Ground	0
Style	1 1/2 Story Frame	Rooms Below Ground	0
Main Area	746	Bedroom #	0
Total Living Area	1,854	Bathroom #	1.75
Length	0	Foundation	None
Width	0	Exterior Walls	Siding
Basement	Full	Roof	Composition Shingle
Basement Area	746.0000	Interior Walls	None
Bsmt Floor Adj	0	Flooring	None
Heating	Yes	Architectural Design	N/A
AC	Yes	Single Siding	No
Attic	None		

Addition 1 of 3	
Year Built	1920
Style	1 1/2 Story Frame
Area	288
Basement SF	0
No Floor Adj (SF)	0
Heat	Yes
AC	Yes
Attic SF	0

Addition 2 of 3	
Year Built	1920
Style	1 Story Frame
Area	72
Basement SF	0
No Floor Adj (SF)	0
Heat	Yes
AC	Yes
Attic SF	0

Addition 3 of 3	
Year Built	1920
Style	1 Story Frame
Area	24
Basement SF	0
No Floor Adj (SF)	0
Heat	Yes
AC	Yes
Attic SF	0

Porches					
Area	Style	Bsmt SF	QTRS SF	Qtrs Style	Qtrs AC
112	1S Frame Enclosed	0	0	Frame	No
64	1S Frame Enclosed	0	0	Frame	No
48	Concrete Stoop/Deck	0	0	Frame	No

Plumbing				
Style	Count	Fixtures	Bathrooms	
Full Bath	1	3	1	
Plumbing (Incl. in Base)	3	3	0.75	
		6	1.75	

Deck and Patio	
Style	SF Area
Asph/Wd Roof OH-Med	48

Garage 1 of 1	
Year Built	1920
Style	Det Frame
WxL	16 x 22
Area	352
Basement SF	0
Qtrs Over Style	None
Qtrs Over SF	0
Qtrs Over AC (SF)	0
Door openers	0





