

AGENDA
CITY COUNCIL, YORK, NEBRASKA
Thursday, May 5, 2022
7:00 PM

THE OPEN MEETINGS ACT IS POSTED ON THE EAST WALL OF THE COUNCIL
CHAMBERS

Public participation in City Council meetings follows the rules established in the City of York Ordinances and the state Open Meetings Act. Pursuant to section 2-32(a) of the City Code and the Open Meetings Act, the presiding officer allows public comments during council meetings on matters designated as public hearings and on matters on the agenda that require passage or other action by the Council. Public comment is not allowed after a motion is made by a council member to pass or act on an agenda item. Comments are not allowed on any item that is not on the agenda to ensure full transparency of discussion items to the public before the meeting as required by the Open Meetings Act.

1. The Open Meetings Act is posted on the East Wall of the Council Chambers
2. Notice of this meeting was published in the York News Times on April 28, 2022
3. Pledge of Allegiance
4. Roll Call
5. Minutes of the April 21, 2022 meeting
6. Claims of Elected Officials
 - 6.1. Claim for Tony North of North Printing & Office Supply in the amount of \$2,212.96
7. Claims for the period of April 22 through May 5, 2022
8. City Administrator Report
9. Arbor Day Foundation Recognizes York as a Tree City USA 2021
10. Consider approval of Change Proposal Request No. 2 for YASWA Phase 6 Liner Construction
11. Discussion with Kevin Burns regarding easement access north of the landfill
12. Consider approval of NMC estimate for repairs of 963D Loader for Landfill in the amount of \$44,746.79
13. Third reading of Amended Ordinance No. 2315 - to amend Chapter 36 of the City code to enact a section to permit the operation of all-terrain vehicles and utility-type vehicles

within the corporate limits of the City as authorized

14. Consider approval of the quote by Sourcewell for the Holthus Playground Project in the amount of \$77,278.00

15. Adjournment

Classifieds

York, Nebraska

www.yorknewstimes.com

Place an ad
402-204-7009 or Mon
thru Fri 8-5pm or go
online at yorknewstimes.com
and check out our classified
link. You may also fax at
402-362-6748

Publishing Deadlines
For Ads Appearing
Call Before
Friday.....Monday at 3pm
Wednesday.....Tuesday at 3pm
Thursday.....Wednesday at 3pm
Friday.....Thursday at 3pm
Saturday.....Friday at 12pm
AD Advantage.....Friday at 12pm

What does it cost?
There are different rates for different categories:
• Real Estate for Sale
• Employment/Work Wanted
• Miscellaneous
• Garage Sales
• Rentals
Call for Specialist!

Selling a Vehicle?
• Five weeks in NYT
• 1 week in Trade West
• 3 days in GI Independent
• 5 weeks AD Advantage includes picture & 20 words for less than \$63
Call for other packages

Get Online
To read ads, place ads and contact the classifieds department go to yorknewstimes.com/classifieds
Employment
ynjobseekers.com

0190 Personals

DO YOU HAVE A QUESTION?
BECKY has been with YAK for almost 6 years. She has worked for Ken for a long time of her own. She is affectionate and always ready for attention. Please consider adopting her into your home and heart. He is currently being fostered on our call. Call LaBare at 402-366-0533 or go on our website www.yorkadoption.com and fill out an application.

We Will Find The Answer! CALL THE WONDERLINE 402-362-4778

0355 Pets & Supplies

96 Ford Winnebago Adventure Motorhome, 32 excellent condition, always stored inside, with a little. Call 308-383-7070

0925 Boats & Marine
Pontoon boat 16' w/ 25 hp mercury
20' fishing pontoon center console w/ 45 hp motor
Call 308-391-2245 or 702-305-2462

0910 RVs, Campers, Motorhomes

13 Dodge Grand Caravan SXT, 4 dr., fully loaded with 80-N-GO seats, DVD, back camera, and Navigation
\$14,995
Call Tim at 308-624-0055 or Kerwyn at 308-390-8925

0970 Pickups, 4x2 or 4x4

15 Chevrolet Silverado 2500HD, really nice Chevy 3 1/2 ton truck. Runs and drives great. New tires, no rust and has lots of life left in it, work truck package, really nice heavy duty tool box with a headache rack.
\$26,495
Call Tim at 308-624-0055 or Kerwyn at 308-390-8925

0970 Pickups, 4x2 or 4x4

15 Chevrolet Silverado 2500HD, really nice Chevy 3 1/2 ton truck. Runs and drives great. New tires, no rust and has lots of life left in it, work truck package, really nice heavy duty tool box with a headache rack.
\$26,495
Call Tim at 308-624-0055 or Kerwyn at 308-390-8925

0995 Autos for Sale or Lease

100 Buck LeSabre 4 door, 182,000 miles \$3,500 (308) 258-4450

0099 LEGALS

NOTICE OF MEETING
Notice is hereby given that a meeting of the Planning Commission of the City of York, Nebraska, will be held at 5:15 o'clock p.m. on Tuesday, May 10, 2022, in the Council Chambers, York Municipal Building, 100 East 4th Street, which meeting will be open to the attendance of the public. An agenda of such meeting, kept continuously current, is available for public inspection at the office of the City Clerk, Amanda Ring, City Clerk, April 28, ZNEZ.

0099 LEGALS

SEVERAL LAW OFFICES, P.C.
A Limited Liability Organization
NOTICE
In the County Court of York County, Nebraska, Estate of Bruce L. Hudson, Deceased, Estate No. PR92-35. Notice is hereby given that on April 19th 2022, in the County Court of York County, Nebraska, this Registrar issued a written statement of Informal Probate of the Will of said Decedent and that Wency S. Hudson, whose address is 2405 Road G, Brookshaw, NE 68319, was informally appointed by the Registrar as Personal Representative of the Estate.
Creditors of this Estate must file their claims with the York County Court, Wednesday May 4th at 510 N. Lincoln Ave., York, NE 68402, on or before June 20th, 2022, or be forever barred.
Aron O'Neil, Clerk of the County Court
Kelly M. Thomas, 11833
kthomas@whitlaw.net
408 N. Platte Ave., York, NE 68402
YORK NE 68407
(402)362-6566
attorney@whitlaw.net
April 21, 2022
ZNEZ

0242 Pointing

HEISS is a super friendly guy. He would be great around other cats and children. He is currently being fostered in your care. Call LaBare at 402-366-0533 or go on our website www.yorkadoption.com and fill out an application.

0960 Auto Accessories

Volkswagen VW Wanted: 1970-1999 Rabbit, Golf Jetta, Corrado. Projects Parts Cars. I have trailer and will travel. Leave Message 1 for Text 402-671-0355

0970 Pickups, 4x2 or 4x4

15 Chevrolet Silverado 2500LT, 4x4, LT 4.8 4.8 Crew Cab, 5.8' SB, back up camera, subwoofers and amplifier, power windows and locks, 3 inch lift with 20 in. balls, Off-Road Flims and 35 inch tires.
PRICE REDUCED!!! \$28,995
MUST SEE TO APPRECIATE!
Call Tim at 308-624-0055 or Kerwyn at 308-390-8925

0980 Sport Utility Vehicles

14 GMC Yukon XL Denali, AWD, 4 dr., with sunroof, heated and air conditioning seats, dual DVD TV, 4x4. Leather loaded with Navigators and lots of extras.
\$28,495
Tim at 308-624-0055 or Kerwyn at 308-390-8925

0991 Minivans, Buses, Vans

14 Toyota Sienna XLE, Wheelchair accessible, floor, Power ramp, Removable front seats, 43,997 miles. \$45,450 or trade.
Mobility Motoring
McCook
308-340-7774

0300 MERCHANDISE

PLEASE CHECK your classified ads for spelling or other errors (category, etc.) York News-Times will only be responsible for a one day error.

0355 Pets & Supplies

MR JAX is a dapper and lovable guy. He loves sunny nooks and follows you from room to room. He would make a wonderful family addition. He is currently being fostered in your care. Call LaBare at 402-366-0533 or go on our website www.yorkadoption.com and fill out an application.

0960 Auto Accessories

13 Dodge Charger SE, 4 door, 4 V6, FWD, good tires.
Don't Miss this GREAT Deal!!! \$12,995
Call Tim at 308-624-0055 or Kerwyn at 308-390-8925

0980 Sport Utility Vehicles

14 GMC Yukon XL Denali, AWD, 4 dr., with sunroof, heated and air conditioning seats, dual DVD TV, 4x4. Leather loaded with Navigators and lots of extras.
\$28,495
Tim at 308-624-0055 or Kerwyn at 308-390-8925

0991 Minivans, Buses, Vans

14 Toyota Sienna XLE, Wheelchair accessible, floor, Power ramp, Removable front seats, 43,997 miles. \$45,450 or trade.
Mobility Motoring
McCook
308-340-7774

0355 Pets & Supplies

MR JAX is a dapper and lovable guy. He loves sunny nooks and follows you from room to room. He would make a wonderful family addition. He is currently being fostered in your care. Call LaBare at 402-366-0533 or go on our website www.yorkadoption.com and fill out an application.

0960 Auto Accessories

13 Dodge Charger SE, 4 door, 4 V6, FWD, good tires.
Don't Miss this GREAT Deal!!! \$12,995
Call Tim at 308-624-0055 or Kerwyn at 308-390-8925

0980 Sport Utility Vehicles

14 GMC Yukon XL Denali, AWD, 4 dr., with sunroof, heated and air conditioning seats, dual DVD TV, 4x4. Leather loaded with Navigators and lots of extras.
\$28,495
Tim at 308-624-0055 or Kerwyn at 308-390-8925

0991 Minivans, Buses, Vans

14 Toyota Sienna XLE, Wheelchair accessible, floor, Power ramp, Removable front seats, 43,997 miles. \$45,450 or trade.
Mobility Motoring
McCook
308-340-7774

RICHARD & BONNIE GUDGEH
HOUSEHOLD ONLINE-ONLY AUCTION
274 lots. Household Items, Antiques, & Vintage Items.
Bidding Ends May 3, Pickup In York May 5.

BID NOW!!!
ONLINE AUCTION LINK: <https://ihbid.com/catalog/93688/richard-and-bonnie-gudgeh-household-auction/>
Antique & Vintage Pieces!
• 3 Piece Antique Oak Bedroom Set
• Antique Oak China Cabinet • Washer and Dryer • 3 Gallon Red Wing Butter Churn • Gallon Crock • Vintage Toys, Including Chinese Checkers • Toro 22" Mulching Mower With Bagger • Toro Snowblower • Antique Oak Rocking Chairs • Recliners • Filing Cabinets
• Early 1900s Phonograph
MANY MORE ITEMS! BID NOW!

ROWSE LAWN CARE
Commercial & Residential Service.
Serving York & Surrounding Communities.
Call today for FREE Estimate
402-363-4645

WE ARE OPEN!
York Adoption Pet
New Shelter Visiting Hours
Thursday - Saturday Noon-3:00pm
Appointments can be made for other days and times by calling the shelter at 402-362-5964.
You can view our pets on: yorkadoption.com

Immediate Availability for 2 and 3 Bedroom Units
Rental Assistance Available to Qualified Applicants
York Del Ray Plaza Townhomes
2220 N. Nebraska Ave., York, NE
Call Park Avenue Management at 715-274-7740 for an application.
TTY: 1-800-433-7352
Equal Housing Opportunity - Handicapped Accessible

York Area Senior Center is looking for a Part-time Activities Director 20 hours per week, 5 days per week with flexible hours.
Applications are available at the York Area Senior Center, 725 N. Lincoln Ave., York, NE

Bioiberica
Bioiberica is a life science company that is big in our industry, but relatively small in size, with fewer than 100 U.S. employees. Position requires mechanical aptitude, attention to detail, independence, and a positive attitude. Work includes, taking samples, process monitoring, running pumps, equipment maintenance and operation, forklift operation, and record keeping. A background in farm labor, manufacturing, or production would be helpful. Health benefits include premiums and deductibles paid by the company (a \$6-\$9/hour benefit).
\$2,000 signing bonus for new hires.
Positions have shift-differential pay and an annual performance bonus program.
Full-time Second shift is 1:00 PM - 9:00 PM. Third shift is 9:00 PM - 5:00 AM. \$18.00 - \$21.00/hour. Please send resume to kelscheiberger@bioiberica.com or fill out the job application at this link: <https://forms.gle/Jr89N9guBfkgGC7>

out with the old. in with the new.
York News-Times Classifieds
www.yorknewstimes.com
To place your ad call 402-362-4473

Educational Service Unit 6 is seeking applicants for the following open positions for 2022-23 school year.
• Speech Language Pathologist
• Early Learning Connection Assistant Coordinator
For more information and application process, visit www.esu6.org. EEO/AF
Please send application and resume to: Nichole Hall Director of HR, Educational Service Unit 6, 210 5th Street - Millard, NE 68405, nichole.hall@esu6.org 402-761-3341

SOYBEAN MULCH FOR SALE
BAGS or BULK
Works in all your landscaping or garden needs.
RATZLAF SOYBEAN MULCH HENDERSON, NE
402-723-4255 or 402-366-3570

NOTICE OF MEETING
Notice is hereby given that a meeting of the City of York, Nebraska, will be held at 7:00 o'clock p.m. on Thursday, May 5, 2022 in the Council Chambers, York Municipal Building, 100 East 4th Street, which meeting will be open to the attendance of the public. An agenda of such meeting, kept continuously current, is available for public inspection at the office of the City Clerk, Amanda Ring, City Clerk, April 28, ZNEZ.

NOTICE OF MEETING
Notice is hereby given that a meeting of the City of York, Nebraska, will be held at 7:00 o'clock p.m. on Thursday, May 5, 2022 in the Council Chambers, York Municipal Building, 100 East 4th Street, which meeting will be open to the attendance of the public. An agenda of such meeting, kept continuously current, is available for public inspection at the office of the City Clerk, Amanda Ring, City Clerk, April 28, ZNEZ.

NOTICE OF MEETING
Notice is hereby given that a meeting of the City of York, Nebraska, will be held at 7:00 o'clock p.m. on Thursday, May 5, 2022 in the Council Chambers, York Municipal Building, 100 East 4th Street, which meeting will be open to the attendance of the public. An agenda of such meeting, kept continuously current, is available for public inspection at the office of the City Clerk, Amanda Ring, City Clerk, April 28, ZNEZ.

Equal Housing Opportunity
All real estate advertising in this newspaper is subject to the Fair Housing Act which makes it illegal to advertise "any preference limitation or discrimination based on race, color, religion, sex, handicap, familial status or national origin, or an intention, to make any such preference, limitation or discrimination." Familial status includes children under the age of 18 living with parents or legal custodians; pregnant women and people securing custody of children under 18. This newspaper will not knowingly accept any advertising for real estate which is in violation of the law. Our readers are hereby informed that all dwellings advertised in this newspaper are available on an equal opportunity basis. To complain of discrimination call HUD toll-free at 1-800-638-9777. The toll-free number for the hearing impaired is 1-800-927-9275. Any reader who suspects an advertiser has discriminated against them should contact the Nebraska Equal Opportunity Commission at (800) 642-6112 or the U.S. Department of Housing and Urban Development, Fair Housing Assistance Division at (800) 669-9777.

MELANIE CONT. FROM PAGE 4A
said, shaking his finger at me.
Again, I inquired as to why.
"Because if you don't vote, you can't bitch about how things go later," he said. "People who don't vote can't bellyache, complain or crab about how things are; if they didn't even take the time to officially say who they thought was good for the job. If you love to crab, then you love to vote."
It stuck with me. A year later, we were sitting at Grandma One's Christmas table and Grandpa Andy was going on and on about something political. He ranted and raved, ranted and raved. In my juvenile misunderstanding of protocol regarding children addressing adults, I decided to pipe up.
"Grandpa, did you vote for the president the last time around?" I asked.
My parents looked at each other, maybe a little shocked, and the table went quiet.
"Well, no, well, I can't remember," Grandpa said. "No, actually, I didn't. Remember, I was down with the shingles. Right Grandpa? Wasn't it the shingles and I was in all that pain?"
Grandpa said she didn't think the shingles afflicted him that particular November, which drove Grandpa nuts. His political tirade was now directed at Grandpa because she disagreed about the month last year when the shingles arrived.
"Well, she's right, Dad," my father said. "If you love to crab, then you love to vote. You can't do one without the other."
Now that Grandpa had been caught with his political pants down, he was embarrassed and the conversation switched from sin tax to shingle treatments.
I don't remember Grandpa ever skipping the polls again. Heck, we kids drove him to vote after he was too old and we were old enough. He always insisted on voting... and crabbing.
The theory is true. If you don't vote, you have voted your right to say anything about the way things are in our nation, our state, our county, our towns, our school districts.
By not voting, you've passed up your one official chance to have a real opportunity to participate in our democracy.
So I continue to remember what my dad said and I suspect maybe you did too... if you love to crab, then you love to vote.

Public notices help expose
• Fraud by governments
• Dishonest businesses
• Unfair competitive practices
Find out about these and much more in your local newspaper!
Participate in Democracy. Read your Public Notices.

**REGULAR MEETING
CITY COUNCIL – YORK, NEBRAKSA
April 21, 2022
7:00 PM o'clock P.M.**

A meeting of the Mayor and City Council of the City of York, Nebraska, was convened in open and public session at 7:00 o'clock p.m. at the Council Chambers.

The Mayor announced that the Open Meetings Act was posted on the east wall of the Council Chambers.

Roll Call

Barry Redfern, Mayor: Present. Sheila Hubbard: Absent, Christi Lones: Present, Tony North: Present, Jeff Pieper: Present, Jennifer Sheppard: Present, Scott Van Esch: Present, Matt Wagner: Present, Jerry Wilkinson: Present.

Hubbard joined the meeting at 7:01 p.m. Sheila Hubbard: Present.

Minutes

Motion to approve the minutes of the April 7, 2022 meeting. Ayes with a motion by Jerry Wilkinson and a second by Tony North.

Hubbard: Absent, Lones: Yea, North: Yea, Pieper: Yea, Sheppard: Yea, Van Esch: Yea, Wagner: Yea, Wilkinson: Yea

Approve cash balances for the month of March 2022

Motion to approve the cash balances for the month of March 2022. Ayes with a motion by Scott Van Esch and a second by Christi Lones.

Hubbard: Yea, Lones: Yea, North: Yea, Pieper: Yea, Sheppard: Yea, Van Esch: Yea, Wagner: Yea, Wilkinson: Yea

Departmental Activities Reports for the month of March 2022

Motion to approve the departmental activities reports for the month of March 2022. Ayes with a motion by Jerry Wilkinson and a second by Jennifer Sheppard.

Hubbard: Yea, Lones: Yea, North: Yea, Pieper: Yea, Sheppard: Yea, Van Esch: Yea, Wagner: Yea, Wilkinson: Yea

Claims of Elected Officials

Motion to approve claim for North Printing & Office Supply in the amount of \$2,005.13. Ayes with a motion by Christi Lones and a second by Jerry Wilkinson.

Hubbard: Yea, Lones: Yea, North: Abstain (With Conflict), Pieper: Yea, Sheppard: Yea, Van Esch: Yea, Wagner: Yea, Wilkinson: Yea

Motion to approve claim for Piepers Inc in the amount of \$347.75. Ayes with a motion by Christi Lones and a second by Jerry Wilkinson.

Hubbard: Yea, Lones: Yea, North: Yea, Pieper: Abstain (With Conflict), Sheppard: Yea, Van Esch: Yea, Wagner: Yea, Wilkinson: Yea

Claims

Motion to approve claims for the period of April 8 through April 21, 2022. Ayes with a motion by Christi Lones and a second by Tony North.

Hubbard: Yea, Lones: Yea, North: Yea, Pieper: Yea, Sheppard: Yea, Van Esch: Yea, Wagner: Yea, Wilkinson: Yea

City Administrator Report

City Administrator, Dr. Sue Crawford, addressed the Council stating that it is already time to prepare for next year's budget. She discussed upcoming meetings and special meetings that will be held so that department heads can present information for their budget and give Council the opportunity to have questions answered.

Third reading of Ordinance No. 2312 - Annexation of property requested DSW Properties LLC

ORDINANCE NO.2312

AN ORDINANCE TO PROVIDE FOR THE ANNEXATION OF LAND AND TO PROVIDE AN EFFECTIVE DATE FOR THIS ORDINANCE.

Motion to approve Ordinance No. 2312 to annex property requested by DSW Properties LLC. Ayes with a motion by Jerry Wilkinson and a second by Scott Van Esch.

Hubbard: Yea, Lones: Yea, North: Yea, Pieper: Yea, Sheppard: Yea, Van Esch: Yea, Wagner: Yea, Wilkinson: Yea. The motion was adopted by a three-fourths vote of the Council.

Second reading of Ordinance No. 2315

The second reading of Ordinance No. 2315 was held. This is an Ordinance presented to permit the operation of ATV/UTVs within the corporate limits of the City. Police Chief, Ed Tjaden, addressed the Council with his concerns regarding enforcement and safety of this ordinance. John Biel and Jeff Beins spoke in favor of the ordinance. Following discussion, the Mayor stated he would like to see this ordinance go back to the Ordinance Committee to amend details that need to be addressed before it is presented for the third reading.

Resolution 2022-11 - City of York Personnel Manual

RESOLUTION NO 2022-11

A RESOLUTION OF THE CITY COUNCIL OF THE CITY OF YORK, NEBRASKA, TO ADOPT A NEW PERSONNEL MANUAL FOR THE EMPLOYEES OF THE CITY OF YORK.

WHEREAS, the Mayor and Council of the City of York, Nebraska, have previously adopted and revised a Personnel Manual for the employees of the City of York, and,

WHEREAS, the Personnel Manual is periodically updated as needed to reflect the current policies of the City affecting its employees,

WHEREAS, in an effort to clarify the record, the Mayor and Council of the City of York, Nebraska, desire to adopt a new Personnel Manual replacing all previously adopted and revised versions,

NOW THEREFORE, BE IT RESOLVED by the Mayor and Council of the City of York as follows:

Section 1. That the Personnel Manual of the City of York, Nebraska, attached hereto as Exhibit A and incorporated herein by this reference, is hereby adopted, effective May 9, 2022, as the City's personnel manual and shall be applicable to all employees, appointed and elected city officials unless preempted by state of federal law or in conflict with an existing employment contract or collective bargaining agreement.

Section 2. That any and all previously adopted or revised versions of the personnel manual for the City of York, Nebraska shall be repealed.

Section 3. That the original of such Personnel Manual shall be maintained in the office of the Human Resource Director, and copies to be made available to all employees of the City.

Human Resource Director, Denise Pfeifer, presented to the Council a highlight of the major changes within the new Personnel Manual.

Motion to approve Resolution 2022-11 for the updated City of York Personnel Manual to be effective May 9, 2022. Ayes with a motion by Jeff Pieper and a second by Christi Lones.

Hubbard: Yea, Lones: Yea, North: Yea, Pieper: Yea, Sheppard: Yea, Van Esch: Yea, Wagner: Yea, Wilkinson: Yea

Public Hearing for Community Development Block Grant Project #20-ED-01-YEDRLF

The second public hearing is a formality under the Community Development Block Grant that is done towards the end of a project once national objectives are met. This hearing provides the public to weigh in on the project and voice any concerns or support they had or may have as it relates to the project. Nixon Restaurant & Property, Inc. dba Jimmy Johns was awarded a loan from York's Reuse Fund in the amount of \$280,000 for working capital and the purchase of equipment to assist with startup costs. The City conditionally granted the funds to Southeast Nebraska Development, Inc. (NDO), who provided the loan to the business and now administers payments. The business was to create 8.0 full-time equivalent positions. 51% to meet LMI. The City of York awarded this project through available program income. The business is current on their payments and has met the national objective of hiring the required FTE positions.

Resolution 2022-10 - Amend Wage scale for Police Captain

Resolution No. 2022-10

WHEREAS, the City of York Police Department amended its Police Union Contract in December 2021 for the September 2021 through September 2022 contract; and

WHEREAS, the officer and sergeant wages increased with the Police Union Contract amendment from December 2021; and

WHEREAS, the wage of the Captain should exceed the wage of officer and sergeant; and

WHEREAS, the Police Department wage budget for 2021-2022 provides necessary resources to correct these classifications for this current budget cycle;

THEREFORE, be it resolved by the City of York, York County, Nebraska, that the Police Captain pay grade be increased from 45.5 to 49.5 effective immediately.

Motion to approve resolution 2022-10 to increase the pay grade for Police Captain effective immediately. Ayes with a motion by Scott Van Esch and a second by Jerry Wilkinson.

Hubbard: Yea, Lones: Yea, North: Yea, Pieper: Yea, Sheppard: Yea, Van Esch: Yea, Wagner: Yea, Wilkinson: Yea

Approve health insurance benefits for City employees

Motion to approve recommendation of insurance committee to update employee's health insurance to include preventative care effective May 1, 2022 through April 30, 2023. Ayes with a motion by Jerry Wilkinson and a second by Sheila Hubbard.

Hubbard: Yea, Lones: Yea, North: Yea, Pieper: Yea, Sheppard: Yea, Van Esch: Yea, Wagner: Yea, Wilkinson: Yea

Change Order No. 2 for the York 2020 Pavement Preservation Project

Motion to approve Change Order No. 2 for the York 2020 Pavement Preservation Project. Ayes with a motion by Jeff Pieper and a second by Tony North.

Hubbard: Yea, Lones: Yea, North: Yea, Pieper: Yea, Sheppard: Yea, Van Esch: Yea, Wagner: Yea, Wilkinson: Yea

Public Hearing for Zoning Ordinance Changes

Dan Aude, Asset Manager, gave a brief description change and reasoning to the Council regarding the zoning changes.

Ordinance No. 2313

AN ORDINANCE TO AMEND THE ZONING DISTRICT MAP FOR THE CITY OF YORK, NEBRASKA TO REMOVE SUBJECT REAL ESTATE FROM THE A-L ZONING DISTRICT AND DESIGNATE SUCH REAL ESTATE TO BE WITHIN THE C-3 ZONING DISTRICT; TO REPEAL ALL ORDINANCES IN CONFLICT HEREWITH; AND TO PROVIDE FOR AN EFFECTIVE DATE FOR THIS ORDINANCE.

Asset Manager, Dan Aude, explained to the Council that this change was necessary for the DSW Properties that was just annexed.

Motion to suspend the rules for Ordinance No. 2313. Ayes with a motion by Scott Van Esch and a second by Jerry Wilkinson.

Hubbard: Yea, Lones: Yea, North: Yea, Pieper: Yea, Sheppard: Yea, Van Esch: Yea, Wagner: Yea, Wilkinson: Yea

Motion to approve Ordinance No. 2313 to amend the zoning district. Ayes with a motion by Jerry Wilkinson and a second by Tony North.

Hubbard: Yea, Lones: Yea, North: Yea, Pieper: Yea, Sheppard: Yea, Van Esch: Yea, Wagner: Yea, Wilkinson: Yea. The motion was adopted by a three-fourths vote of the Council and the Statutory Rule suspended for consideration of said Ordinance on its second and third reading.

Ordinance No. 2320

AN ORDINANCE OF THE CITY OF YORK, NEBRASKA TO AMEND ARTICLE III, SECTION 2 DEFINITIONS, OF THE ZONING ORDINANCE OF THE CITY OF YORK, NEBRASKA TO ADD A DEFINITION FOR "DATA CENTER"; TO REPEAL ALL ORDINANCES IN CONFLICT HEREWITH; AND TO PROVIDE FOR AN EFFECTIVE DATE FOR THIS ORDINANCE.

Motion to suspend the rules for Ordinance No. 2320. Ayes with a motion by Jeff Pieper and a second by Sheila Hubbard.

Hubbard: Yea, Lones: Yea, North: Yea, Pieper: Yea, Sheppard: Yea, Van Esch: Yea, Wagner: Yea, Wilkinson: Yea

Motion to approve Ordinance No. 2320 to add a "Data Center" definition. Ayes with a motion by Jeff Pieper and a second by Scott Van Esch.

Hubbard: Yea, Lones: Yea, North: Yea, Pieper: Yea, Sheppard: Yea, Van Esch: Yea, Wagner: Yea, Wilkinson: Yea. The motion was adopted by a three-fourths vote of the Council and the Statutory Rule suspended for consideration of said Ordinance on its second and third reading.

Ordinance No. 2321

AN ORDINANCE TO AMEND ARTICLE XVIII "I" INDUSTRIAL DISTRICT OF THE ZONING CODE OF THE CITY OF YORK, NEBRASKA, TO ADD "DATA CENTERS" AS A PERMITTED USE; TO REPEAL ALL ORDINANCES IN CONFLICT HEREWITH; AND TO PROVIDE FOR AN EFFECTIVE

DATE FOR THIS ORDINANCE.

Motion to suspend the rules for Ordinance No. 2321. Ayes with a motion by Christi Lones and a second by Sheila Hubbard.

Hubbard: Yea, Lones: Yea, North: Yea, Pieper: Yea, Sheppard: Yea, Van Esch: Yea, Wagner: Yea, Wilkinson: Yea

Motion to approve Ordinance No. 2321 to update the industrial zoning district to include data centers as a permitted use. Ayes with a motion by Jennifer Sheppard and a second by Jeff Pieper.

Hubbard: Yea, Lones: Yea, North: Yea, Pieper: Yea, Sheppard: Yea, Van Esch: Yea, Wagner: Yea, Wilkinson: Yea. The motion was adopted by a three-fourths vote of the Council and the Statutory Rule suspended for consideration of said Ordinance on its second and third reading.

Ordinance No. 2322

AN ORDINANCE TO AMEND ARTICLE VI "A-L" AGRICULTURAL DISTRICT, SECTION 3(17) TO ALLOW DATA CENTERS BY SPECIAL PERMIT; REPEAL OF ALL ORDINANCES IN CONFLICT HEREWITH; AND TO PROVIDE FOR THE EFFECTIVE DATE OF THIS ORDINANCE.

Motion to suspend the rules for Ordinance No. 2322. Ayes with a motion by Sheila Hubbard and a second by Scott Van Esch.

Hubbard: Yea, Lones: Yea, North: Yea, Pieper: Yea, Sheppard: Yea, Van Esch: Yea, Wagner: Yea, Wilkinson: Yea

Motion to approve Ordinance No. 2322 to allow data centers in the "A-L" agricultural district by special permit. Ayes with a motion by Christi Lones and a second by Jerry Wilkinson.

Hubbard: Yea, Lones: Yea, North: Yea, Pieper: Yea, Sheppard: Yea, Van Esch: Yea, Wagner: Yea, Wilkinson: Yea. The motion was adopted by a three-fourths vote of the Council and the Statutory Rule suspended for consideration of said Ordinance on its second and third reading.

Allocation of funds for Downtown Revitalization Project #21-DTR-014

Madonna Mogul, with the York Chamber of Commerce, gave a brief description of each of the following projects and what renovations the funds will be used for.

Consider approval of #21-DTR-014 Facade Improvement Program to BLT Rentals, LLC, 114, 116, 118 W. 6th Street, for roof repair, gutters and downspouts, in the amount of \$8,977.50, total project cost is \$11,970.00

Consider approval of #21-DTR-014 Facade Improvement Program to BLT Rentals, LLC, 609 1/2 N. Lincoln Ave, for reconstruction, in the amount of \$22,275.00, total project cost \$29,700.00

Consider approval of #21-DTR-014 Facade Improvement Program to Cyclone Properties LLC, 115 E. 6th Street, for new windows/door, update electrical, and restore the front of the building, in the amount of \$48,585.00, total project cost \$64,780.00

Consider approval of #21-DTR-014 Facade Improvement Program to Mogul's Transmission Inc., 924 N. Grant Ave, for signs and awnings and electrical, in the amount of \$50,000.00, total project cost \$69,273.36.00

Consider approval of #21-DTR-014 Facade Improvement Program to Penner's Tire & Auto, Inc., 903 N. Lincoln Ave, to repair & restore the interior and exterior of the building, in the amount of \$44,799.00, total project cost \$59,733.00

Consider approval of #21-DTR-014 Facade Improvement Program to Eucharisteo LLC, 223 E. 8th Street, for ADA compliant ramps, soffit/fascia replacement, window replacement and installation of business sign, in the amount of \$20,563.76, total project cost \$27,418.34

Consider approval of #21-DTR-014 Facade Improvement Program to Yorkshire Playhouse Inc., 515 N. Lincoln Ave, for Phase 2 of replacing signage, masonry, carpentry to repair and paint front of the building, in the amount of \$50,000.00, total project cost \$76,171.00

Motion to approve funding to all seven applicants for restorations/renovations as listed. Ayes with a motion by Sheila Hubbard and a second by Scott Van Esch.

Hubbard: Yea, Lones: Yea, North: Yea, Pieper: Yea, Sheppard: Yea, Van Esch: Yea, Wagner: Yea, Wilkinson: Yea

Adjournment

There being no further business to come before the Council, the Mayor adjourned the meeting, that time being 8:07 o'clock p.m.

SORTED BY VENDOR

VENDOR	NAME	NO# INVOICES	TOTAL AMOUNT	1099 G/L ACCT NO#	G/L NAME	G/L AMOUNT
01-00010	GALE	5	312.65	N		
01-00090	THE HOME DEPOT PRO	3	909.92	N		
01-00110	MATHESON TRI-GAS	3	305.07	N		
01-00120	JACKSON SERVICES INC	12	535.06	N		
01-00150	MISSIONSQUARE RETIREMENT	2	555.37	N		
01-00200	NEBRASKA MACHINERY CO	9	4,067.43	N		
01-00210	EAKES OFFICE PLUS	2	4,474.02	N		
01-00290	NORTH PRINTING & OFFICE S	15	2,212.96	N		
01-00300	BLACK HILLS ENERGY	13	8,554.19	N		
01-00340	BOUND TREE MEDICAL LLC	1	386.00	N		
01-00360	CITY OF YORK	5	30,535.08	N		
01-00540	GLOBAL TECH, INC.	5	5,629.77	N		
01-00620	ROY NICKELS	1	254.58	N		
01-00640	NEBRASKA PUBLIC POWER DIS	2	4,197.46	N		
01-00680	NE DEPT. OF AERONAUTICS	1	543.33	N		
01-00710	OVERLAND SAND & GRAVEL	7	6,395.08	N		
01-00740	TK ELEVATOR CORP	2	867.38	N		
01-00780	PRESTO X COMPANY	5	175.37	N		
01-00800	BURST, LLC	22	808.68	N		
01-01090	BAKER & TAYLOR, INC	3	674.59	N		
01-01270	NABER'S REPAIRSERVICE	1	9.00	Y		
01-01290	GRAND CENTRAL FOODS, INC.	11	341.95	N		
01-01300	VOSS LIGHTING	1	2,301.84	N		
01-01310	PIEPER PLBG/WELLD RILLING	5	2,874.40	N		
01-01330	JLC, INCORPORATED	5	217.81	N		
01-01390	AFLAC	4	698.16	N		

SORTED BY VENDOR

VENDOR	NAME	NO# INVOICES	TOTAL AMOUNT	1099 G/L ACCT NO#	G/L NAME	G/L AMOUNT
01-01420	NE CHILD SUPPORT PAYMENT	1	104.77	N		
01-01460	PERENNIAL POWER	1	13,039.26	N		
01-01470	SERVI-TECH LABORATORIES	2	140.30	N		
01-01490	NE DEPT OF REVENUE	2	8,205.16	N		
01-01510	HACH CO.	1	185.78	N		
01-01640	INTERNAL REVENUE SERVICE	4	46,599.83	N		
01-01650	UNION BANK	6	27,550.29	N		
01-01670	FRATERNAL ORDER OF POLICE	2	720.00	N		
01-01750	NEBRASKA PUBLIC HEALTH EN	1	210.00	N		
01-01940	SARGENT DRILLING	1	3,692.45	N		
01-01980	SAHLING KENWORTH INC	2	1,435.30	N		
01-02010	YORK EQUIPMENT, INC.	1	359.96	N		
01-02210	KING'S GLASS	2	102.36	N		
01-02230	MCCORMICK HEATING & AC	2	28,332.50	N		
01-02250	MILLER SEED & SUPPLY CO	2	1,018.30	N		
01-02530	PEPSI COLA OF LINCOLN/ TO	4	3,717.83	N		
01-02560	CITYSERVICEVALCON LLC	1	281.49	N		
01-02590	ADOPT A PET	1	2,500.00	N		
01-02650	O'REILLY AUTO PARTS	1	37.22	N		
01-02850	NEWMAN TRAFFIC SIGNS	3		N		
01-02920	FALLER LANDSCAPE	3	721.97	N		
01-03020	MIKE QUBTY	2	105.85	Y		
01-03240	YORK COUNTY DEVELOPMENT C	1	7,500.00	N		
01-03260	HOMETOWN LEASING	2	132.02	N		
01-03930	YORK CHAMBER OF COMMERCE	2	2,129.30	N		
01-04050	GALLS INCORPORATED	1	158.99	N		
01-04420	SOUTHEAST NE DEV DIST	1	3,093.75	N		

SORTED BY VENDOR

VENDOR	NAME	NO# INVOICES	TOTAL AMOUNT	1099 ACCT NO#	G/L ACCT NO#	G/L NAME	G/L AMOUNT
01-05310	SAPP BROTHERS PETROLEUM,	4	7,992.70	N			
01-06120	NEBRASKA RURAL WATER ASSO	1	275.00	N			
01-06410	CASH-WA DISTRIBUTING	2	588.18	N			
01-06490	CROSSROADS AWARDS	1	62.00	Y			
01-07130	AMERICAN TEST CENTER, INC	1	1,102.00	N			
01-07330	PUSH PEDAL PULL	1	849.26	N			
01-08000	NEVCO SCOREBOARD CO	1	198.48	N			
01-08400	CREDIT MANAGEMENT SERVICE	1	48.00	N			
01-08410	BEACON ATHLETICS	1	3,423.00	N			
01-09090	WINDSTREAM	4	854.05	N			
01-09610	B & D DIAMOND PRO INC	1	250.00	N			
01-1	MISCELLANEOUS VENDOR	4	348.80	N			
01-10070	RAILROAD MANAGEMENT COMPA	1	313.34	N			
01-10710	YORK COUNTY SPORTS AUTHOR	1	1,000.00	N			
01-10840	TOTAL ADMINISTRATIVE SERV	3	3,613.62	N			
01-10860	HITZ TOWING	2	306.37	N			
01-11190	MEAD LUMBER & RENTAL	1	8.40	N			
01-11220	PAUL DAVIS RESTORATION &	1	80.00	N			
01-12810	HUFFY'S AIRPORT WINDSOCKS	1	756.70	N			
01-13180	UNITED RENTALS, INC	1	1,064.75	N			
01-14420	911 CUSTOM	1	118.95	N			
01-14470	FARMERS COOPERATIVE	1	14.00	N			
01-14670	OCLC INC	1	466.79	N			
01-14740	BRIAN QUICK	1	82.17	N			
01-14850	CHEREE FOLTS	2	80.00	N			
01-15280	ERICK BREKKE	3	612.22	N			
01-15560	TRUCK CENTER	2	2,033.73	N			

SORTED BY VENDOR

VENDOR	NAME	NO# INVOICES	TOTAL AMOUNT	1099 ACCT NO#	G/L ACCT NO#	G/L NAME	G/L AMOUNT
01-15880	CHARLIE'S U-SAVE RX	1	149.59	N			
01-15980	HDR ENGINEERING INC	7	26,029.60	N			
01-16030	NOVA FITNESS EQUIP CO	1	1,633.34	N			
01-16050	DAWSON ELECTRIC INC	1	723.04	N			
01-16290	MICHAELA STUHR	1	173.16	N			
01-16750	RR DONNELLEY	1	127.51	N			
01-17020	CONSOLIDATED MANAGEMENT C	2	177.74	N			
01-17590	TLS CONSTRUCTION LLC	1	29,765.55	N			
01-19590	COLONIAL LIFE	4	811.56	N			
01-19600	AMERITAS	3	651.60	N			
01-19880	JEREME MINER	2	411.83	N			
01-21320	CULLIGAN	1	42.50	N			
01-21730	HERB'S WINDOW SERVICE	1	993.00	Y			
01-21770	JANSSEN FORD	1	142.39	N			
01-22050	HEAVY METAL SUPPLY CO	1	17.99	N			
01-22100	SLACK AUTO SUPPLY LLC	1	169.95	N			
01-22670	NATIONWIDE INS	1	198.00	N			
01-22700	SPECTRUM BUSINESS	1	1,359.09	N			
01-23070	AMERICAN RED CROSS	1	369.00	N			
01-23260	KERRY'S RESTAURANT & CATE	1	858.00	N			
01-23780	CENTER FOR EDUCATION & EM	1	159.00	N			
01-24120	FIRESRING	1	140.00	N			
01-24250	JEFFERSON COMMUNITY HEALT	2	10.00	N			
01-25100	NEBRASKA RURAL RADIO ASSO	1	668.00	Y			
01-25730	MUNSTER TINT & VINYL LLC	1	264.00	N			
01-26010	SOARIN GROUP	1	790.50	N			
01-26450	STENGER PLUMBING	1	195.00	N			

SORTED BY VENDOR

VENDOR	NAME	NO# INVOICES	TOTAL AMOUNT	1099 ACCT NO#	G/L ACCT NO#	G/L NAME	G/L AMOUNT
01-26480	CONNER PSYCHOLOGICALSERV	1	385.00	N			
01-27390	NORTHLAND BUSINESSSYSTEM	1	1,865.26	N			
01-27400	WY-AD ENTERPRISES LLC	1	23,741.93	Y			
01-27420	DAN SLOCUM	1	114.60	N			
01-27490	SUE CRAWFORD	3	69.73	N			
01-27990	HANS JOHNSON	1	484.13	Y			
01-28000	FRANK BILLINGTON	1	200.00	N			
01-28030	JACOB STUTZMAN	1	150.00	Y			
01-28380	FREEDOMREPAIR & MOTORSP	4	6,403.24	N			
01-28390	BEN RODENBURG	1	1,037.48	N			
01-28540	AMAZON BUSINESS	6	229.42	N			
01-28640	KRVN-AM	1	552.00	N			
01-28680	AD SCREEN GROUP	1	6,000.00	N			
01-28690	DEFENSE TECHNOLOGY	1	150.00	N			
01-28700	THE FLOOR PLAN	1	2,805.60	N			
01-28720	ICMA MEMBERSHIP RENEWALS	1	1,150.00	N			
01-28730	PRIMARY PHARMACEUTICALS	3	1,102.04	N			
*** REPORT TOTALS ***		313	370,925.71				
		Payroll	154,441.15				
		Total	525,366.86				

SELECTION CRITERIA

VENDOR SET: 01 CITY OF YORK
VENDOR: ALL
BANK: ALL
VENDOR CLASS(ES): ALL CLASSES

TRANSACTION SELECTION

REPORTING: PAID ITEMS

	=====PAYMENT DATES=====	=====ITEM DATES=====	=====POSTING DATES=====
PAID ITEMS DATES	: 4/22/2022 THRU 5/05/2022	0/00/0000 THRU 99/99/9999	0/00/0000 THRU 99/99/9999

PRINT OPTIONS

REPORT SEQUENCE: VENDOR #
G/L EXPENSE DISTRIBUTION: NO
CHECK RANGE: 000000 THRU 999999

FOR IMMEDIATE RELEASE

Contact:

Arbor Day Foundation

Lauren Weyers

lweyers@arborday.org

Arbor Day Foundation Recognizes York as a Tree City USA®
York earns the Tree City USA recognition for their commitment to urban forestry

LINCOLN, Nebraska (3/29/2022) – York was named a 2021 Tree City USA by the Arbor Day Foundation to honor its commitment to effective urban forest management.

York achieved Tree City USA recognition by meeting the program's four requirements: forming a tree board or department, creating a tree-care ordinance, having an annual community forestry budget of at least \$2 per capita, and an Arbor Day observance and proclamation. The Tree City USA program is sponsored by the Arbor Day Foundation, in partnership with the U.S. Forest Service and the National Association of State Foresters.

"Tree City USA communities benefit from the positive effects that an urban tree canopy has year after year," said Dan Lambe, chief executive of the Arbor Day Foundation. "The trees being planted and cared for by York ensure that generations to come will enjoy a better quality of life. Additionally, participation in this program helps cultivate a sense of stewardship and pride for the trees the community plants and cares for."

Planting trees in an urban space comes with a myriad of [benefits](#) past the recognition of this program. Urban tree plantings help reduce energy consumption by up to 25%, which will reduce general energy costs and help with the overall cooling of the city as well. In addition, members of the community benefit from properly placed trees as they increase property values from 7–20%. Trees also positively affect the local ecosystem by helping to clean water and create animal habitats to encourage biodiversity.

More information on the program is available at arborday.org/TreeCityUSA.

About the Arbor Day Foundation

Founded in 1972, the Arbor Day Foundation has grown to become the largest nonprofit membership organization dedicated to planting trees, with more than one million members, supporters and valued partners. Since 1972, almost 500 million Arbor Day Foundation trees have been planted in neighborhoods, communities, cities and forests throughout the world. Our vision is to lead toward a world where trees are used to solve issues critical to survival.

As one of the world's largest operating conservation foundations, the Arbor Day Foundation, through its members, partners and programs, educates and engages stakeholders and communities across the globe to involve themselves in its mission of planting, nurturing and celebrating trees. More information is available at arborday.org.



Change Proposal Request No. 02

Date of Initiation: 4/19/2022	Initiated By: YASWA
Owner: YASWA	Owner's Contract No.: N/A
Contractor: VanKirk Bros.	Contractor's Project No.: N/A
Engineer: HDR Engineering, Inc.	Engineer's Project No.: 10336220
Project: YASWA Phase 6 Liner	Contract Name: Same as project

The following change in the contract for this project is proposed. A breakdown of cost shall be attached, and no work shall be commenced until authorized by the Owner.

Description of the Proposed Change(s):

- Transformer pad requested to be relocated approximately 65-feet to the north from the position as provided within the Issue for Bid plan set so as to maintain existing grade at monitoring well MW-17. In addition, a 12-foot-wide roadway is proposed to be placed along the east side of the perimeter access road so as to provide permanent access to monitoring well MW-17. This roadway will require placement of owner supplied aggregate identical to that of the perimeter access road. See **Figure 1** (attachment) for proposed grading. Payment for these items will be based on contracted unit costs.
 - Total Cut – 260 CY Total Fill – 470 CY NET – 210 CY
 - 470 CY x 1.35 = 634.5 CY @ \$3.80/CY = **\$2,411.10 (Increase)**
 - Aggregate Placement – 48 CY
 - 48 CY @ \$12.00/CY = **\$576.00 (Increase)**
 - Total = \$2,411.10 + \$576.00 = \$2,987.10 (Increase)**

By: Will Nicholson

All work shall be in accordance with the terms, stipulations, and conditions of the original Contract Documents. If the work herein provided for is approved by Change Order, the change in Contract Price and Contract Time will be:

Contract Price \$ 2,987.10 Increase.

Contract Time 3 days Increase.

Basis of estimated change in Contract Price:

- | | |
|--|--|
| <input checked="" type="checkbox"/> Lump Sum | <input checked="" type="checkbox"/> Unit Price |
| <input type="checkbox"/> Cost of the Work | <input type="checkbox"/> Other |

Proposed By:
HDR Engineering

Engineer Recommendation
 Recommend Acceptance
 Do Not Recommend Acceptance

Owner's Action
 Accepted
 Not Accepted

By: Contractor

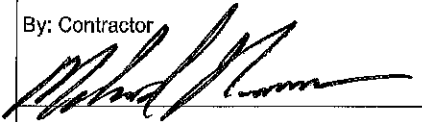

By: HDR Engineering, Inc.

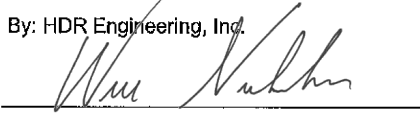

By: Owner

4-26-2022
Date

4/26/2022
Date

Date

AMENDED ORDINANCE NO. 2315

AN ORDINANCE TO AMEND CHAPTER 36 OF THE YORK CITY CODE TO ENACT A SECTION TO PERMIT THE OPERATION OF ALL-TERRAIN VEHICLES AND UTILITY-TYPE VEHICLES WITHIN THE CORPORATE LIMITS OF THE CITY AS AUTHORIZED BY NEB. REV. STAT. §60-6,356(3); TO IMPOSE A PENALTY FOR THE VIOLATION OF THIS SECTION; TO REPEAL ALL ORDINANCES IN CONFLICT HEREWITH; AND TO PROVIDE FOR AN EFFECTIVE DATE FOR THIS ORDINANCE.

BE IT ORDAINED BY THE MAYOR AND CITY COUNCIL OF THE CITY OF YORK, NEBRASKA:

Section 1. Chapter 36 of the City Code of the City of York, Nebraska is hereby amended to enact a section to permit the operation of all-terrain vehicles and utility-type vehicles within the corporate limits of the City as provided herein.

Section 2. Chapter 36 of the City Code is amended to enact the following section:

Section 36-293. All-terrain vehicles and utility-type vehicles authorized to be operated within the corporate limits of the City.

All-terrain vehicles and utility-type vehicles as defined in Neb. Rev. Stat. §60-6,355 may be operated within the corporate limits of the City as authorized by Neb. Rev. Stat. §60-6,356. Any operator of an all-terrain vehicle or a utility-type vehicle shall comply with all conditions and requirements for the operation of such vehicle as provided in Neb. Rev. Stat. §60-6,356 and Neb. Rev. Stats. §§60-6,355 through 60-6,361 R.R.S. as amended.

Section 3. In addition to the conditions and requirements provided by state law, the following conditions and requirements shall apply to the operation of an all-terrain vehicle and utility-type vehicle in the corporate limits of the City:

- A. Such vehicles may only be operated on streets with speed limits of 30 miles per hour or less, and may not be operated on any City trails, paths, drives or other City property.
- B. Any person who operates an all-terrain vehicle or utility-type vehicle shall first obtain a permit from the York Police Department. The Department shall inspect the vehicle to insure its compliance with all requirements imposed by state statute and this section. A permit for the operation of the vehicle shall be issued by the Police Department upon payment of a fee of fifty dollars (\$50), and upon determination that the vehicle complies with all legal requirements. requirements. The owner shall provide proof of insurance as provided by Neb. Rev.

Stat. §60-6,356, to the Police Department to obtain a permit as provided by this section. The permit shall be good for one year, and it shall be unlawful to operate such vehicle without a valid permit in effect.

- C. Every all-terrain vehicle and utility-type vehicle shall be equipped with a brake light that is in good working condition.
- D. Except as otherwise provided by §60-6,355 to 60-6,359, the operator of an all-terrain vehicle and utility-type vehicle shall comply with and be subject to all of the statutory requirements for the operation of a motor vehicle in the State of Nebraska. Operators of an all-terrain vehicle and utility-type vehicle shall comply with all Nebraska statues regarding the use of a child restraint system as required for motor vehicles.

Section 4. Any person who violates this ordinance shall be punished by a fine of zero to five hundred dollars, and shall have his or her permit to operate an all-terrain vehicle or utility-type vehicle revoked.

Section 5. All ordinances and parts of ordinances in conflict herewith are hereby repealed.

Section 6. This ordinance shall be in full force and effect from and after its passage, approval and publication pursuant to law.

PASSED AND APPROVED by the York City Council this ____ day of _____, 2022.

Barry Redfern, Mayor

ATTEST:

Amanda Ring, City Clerk

ORIGINAL ORDINANCE NO. 2315

AN ORDINANCE TO AMEND CHAPTER 36 OF THE YORK CITY CODE TO ENACT A SECTION TO PERMIT THE OPERATION OF ALL-TERRAIN VEHICLES AND UTILITY-TYPE VEHICLES WITHIN THE CORPORATE LIMITS OF THE CITY AS AUTHORIZED BY NEB. REV. STAT. §60-6,356(3); TO IMPOSE THE PENALTY PROVIDED BY STATE LAW FOR THE VIOLATION OF THIS SECTION; TO REPEAL ALL ORDINANCES IN CONFLICT HEREWITH; AND TO PROVIDE FOR AN EFFECTIVE DATE FOR THIS ORDINANCE.

BE IT ORDAINED BY THE MAYOR AND CITY COUNCIL OF THE CITY OF YORK, NEBRASKA:

Section 1. Chapter 36 of the City Code of the City of York, Nebraska is hereby amended to enact a section to permit the operation of all-terrain vehicles and utility-type vehicles within the corporate limits of the City as provided herein.

Section 2. Chapter 36 of the City Code is amended to enact the following section:

Section 36-293. All-terrain vehicles and utility-type vehicles authorized to be operated within the corporate limits of the City.

All-terrain vehicles and utility-type vehicles as defined in Neb. Rev. Stat. §60-6,355 may be operated within the corporate limits of the City as authorized by Neb. Rev. Stat. §60-6,356. Any operator of an all-terrain vehicle or a utility-type vehicle shall comply with all conditions and requirements for the operation of such vehicle as provided in Neb. Rev. Stat. §60-6,356 and Neb. Rev. Stats. §§60-6,355 through 60-6,361 R.R.S. as amended.

Section 3. In addition to the conditions and requirements provided by state law, the following conditions and requirements shall apply to the operation of an all-terrain vehicle and utility-type vehicle in the corporate limits of the City:

- A. Such vehicles may only be operated on streets with speed limits of 25 miles per hour or less.
- B. Any person who operates an all-terrain vehicle or utility-type vehicle shall first obtain a permit from the York Police Department. The Department shall inspect the vehicle to insure its compliance with all requirements imposed by state statute and this section. A permit for the operation of the vehicle shall be issued by the Police Department upon payment of a twenty five dollar and no/100 (\$25.00) fee and upon determination that the vehicle complies with all legal requirements. The permit shall be good for one year, and it shall be

unlawful to operate such vehicle without a valid permit in effect.

- C. Every all-terrain vehicle and utility-type vehicle shall be equipped with a brake light that is in good working condition.

Section 4. Any person who violates this section shall be punished as provided Neb. Rev. Stat. §60-6,362, and shall be guilty of a Class III misdemeanor, as provided by that section.

Section 5. All ordinances and parts of ordinances in conflict herewith are hereby repealed.

Section 6. This ordinance shall be in full force and effect from and after its passage, approval and publication pursuant to law.

PASSED AND APPROVED by the York City Council this ____ day of _____, 2022.

Barry Redfern, Mayor

ATTEST:

Amanda Ring, City Clerk

F:\NET\NODE3\CHARLIE\YORK\ORDINANCES\AllTerrainVehicleOrdUpdated02082022.wpd

Holthus Community Center Holthus Playground

Proposal # 905-152218-1
March 31, 2022

Presented by
Creative Sites, LLC



Burke®



March 31, 2022

Terri Carlson
Holthus Community Center
3130 Holen Avenue
York, NE 68467

Dear Terri Carlson:

Creative Sites, LLC is delighted to provide Holthus Community Center with this playground equipment proposal.

This design was developed with your specific needs in mind, and we look forward to discussing this project further with you to ensure your complete satisfaction. Creative Sites, LLC is confident that this proposal will satisfy Holthus Community Center's functional, environmental, and safety requirements -- and most importantly -- bring joy and excitement to the children and families directly benefiting from your new playground.

You have our personal commitment to support this project and your organization in every manner possible, and we look forward to continue developing a long-standing relationship with Holthus Community Center. We appreciate your consideration and value this opportunity to earn your business.

Sincerely,

Julie Kutilek
Creative Sites, LLC
11506 Pierce St
Omaha, NE 68144

Design Summary

Creative Sites, LLC is very pleased to present this Proposal for consideration for the Holthus Playground located in York. BCI Burke Company, LLC has been providing recreational playground equipment for over 90 years and has developed the right mix of world-class capabilities to meet the initial and continuing needs of Holthus Community Center. We believe our proposal will meet or exceed your project's requirements and will deliver the greatest value to you.

The following is a summary of some of the key elements of our Proposal:

- Project Name: Holthus Playground
- Project Number: 905-152218-1
- User Capacity: 68
- Age Groups: Ages 5-12 years
- Dimensions: 33' 7" x 42' 0"
- Designer Name: John Uelmen

Creative Sites, LLC has developed a custom playground configuration based on the requirements as they have been presented for the Holthus Playground playground project. Our custom design will provide a safe and affordable playground environment that is aesthetically pleasing, full of fun for all users and uniquely satisfies your specific requirements. In addition, proposal # 905-152218-1 has been designed with a focus on safety, and is fully compliant with ASTM F1487 and CPSC playground safety standards.

We invite you to review this proposal for the Holthus Playground playground project and to contact us with any questions that you may have.

Thank you in advance for giving us the opportunity to make this project a success.



SERIES: Intensity, Nucleus
 SITE PLAN
 DRAWN BY: John Uelmen

Holthus Playground
 3130 Holen Avenue
 York, NE 68467

March 31, 2022
 Creative Sites, LLC
 905-152218-1

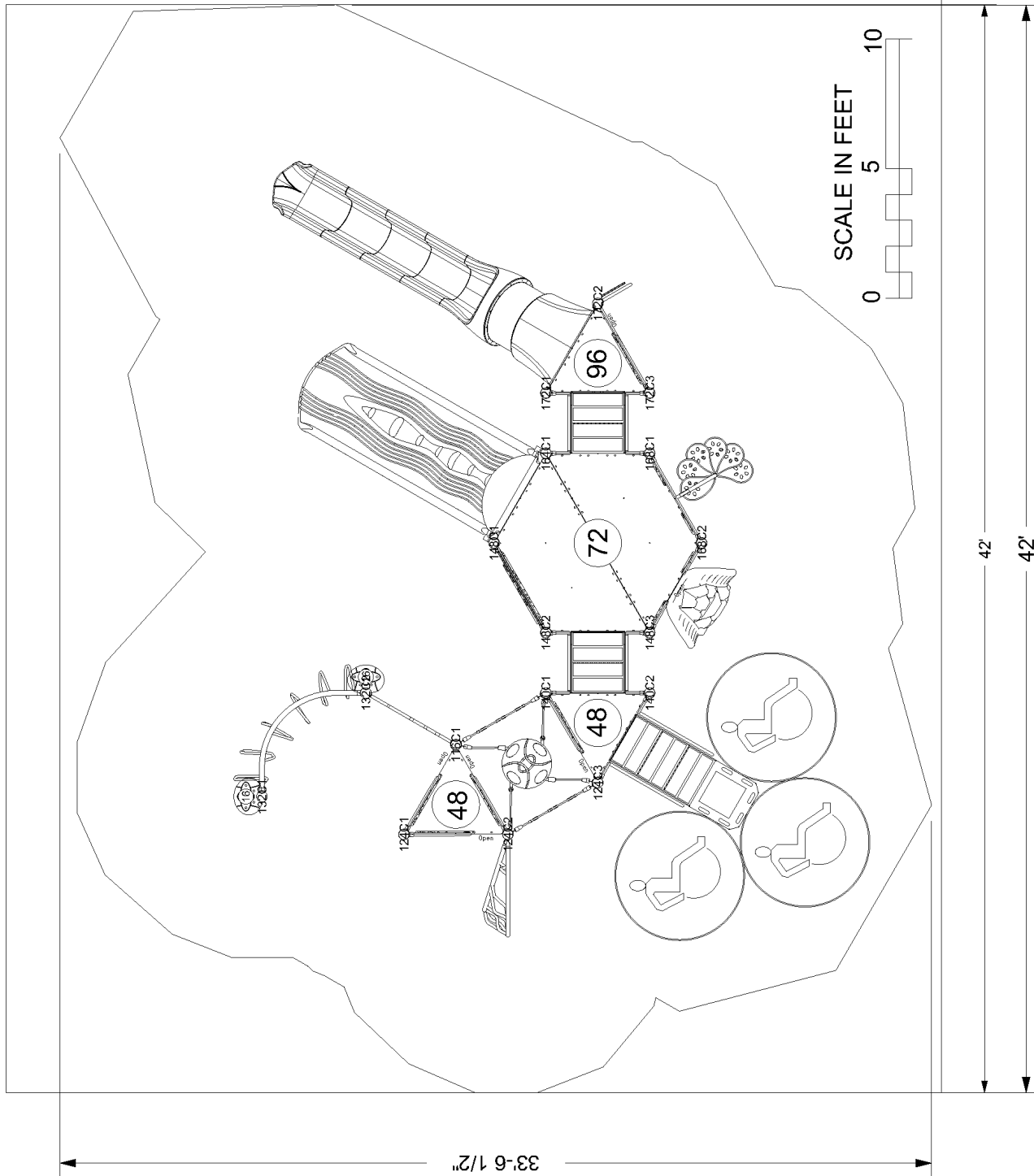

INFORMATION
 MINIMUM FALL ZONE SURFACED WITH RESILIENT MATERIAL AREA
 1033 SQ.FT.
 PERIMETER
 131 FT.
 STRUCTURE SIZE
 33' 7" x 42' 0"
 STRUCTURE IS DESIGNED FOR CHILDREN AGES:
 6-23 MONTH OLDS
 2-5 YEAR OLDS
 5-12 YEAR OLDS
 13 + YEAR OLDS



The play components identified in this plan are IPEMA certified. The use and layout of these components conform to the requirements of ASTM F1487. To verify product certification, visit www.ipema.org

The space requirements shown here are to ASTM standards. Requirements for other standards may be different.

The use and layout of play components identified in this plan conform to the CPSC guidelines. U.S. CPSC recommends the separation of age groups in playground layouts.

ADA ACCESSIBILITY GUIDELINE (ADAAG CONFORMANCE)

NUMBER OF PLAY EVENTS:	11
NUMBER OF ELEVATED PLAY EVENTS:	8
NUMBER OF ELEVATED PLAY EVENTS ACCESSIBLE BY RAMP:	PROVIDED: 0
NUMBER OF ELEVATED PLAY EVENTS ACCESSIBLE BY TRANSFER SYSTEM:	PROVIDED: 6
NUMBER OF ELEVATED PLAY EVENTS ACCESSIBLE BY RAMP OR TRANSFER SYSTEM:	PROVIDED: 3
NUMBER OF GROUND LEVEL PLAY EVENTS:	PROVIDED: 3
NUMBER OF TYPES OF GROUND LEVEL PLAY EVENTS:	RECD: 0
	RECD: 4
	RECD: 3
	RECD: 3

WARNING!
 ACCESSIBLE SAFETY SURFACING MATERIAL IS REQUIRED BENEATH AND AROUND THIS EQUIPMENT.
 FOR SLIDE FALL ZONE SURFACING AREA SEE CPSC's Handbook for Public Playground Safety.
 PLATFORM HEIGHTS ARE IN INCHES ABOVE RESILIENT MATERIAL.

ITEM	COMP.	DESCRIPTION
1	270-0120	EVOLUTION UNITARY ENCLOSURE
2	270-0121	EVOLUTION STANCHION
3	270-0122	EVOLUTION OFFSET ENCLOSURE
4	270-0129	TRIANGLE PLATFORM
5	270-0131	HEXAGONAL PLATFORM S5P
6	370-0467	24" TRANSITION STAIR W/BARRI
7	370-0868	TREE BRANCH CLIMBER-4
8	370-1608	OVISTEP LAUNCH PAD
9	370-1622	TAKTIKS TRAIL TOWER
10	370-1648	MANITOU CLIMBER 72"
11	370-1659	TRANSFER STATION, HANDRAIL
12	370-1666	SHASTA CLIMBER, 80"-96"
13	370-1673	PETAL STEP CLIMBER 64"-72"
14	370-1677	90 DEGREE OVERHEAD, NUCLE
15	370-1696	VIA CLIMBER 48"-56"
16	470-0781	COBRA FUSION STRAIGHT 96"
17	470-0803	CONTOUR SLIDE, 64"-72"
18	570-0100	EVOLUTION BARRIER
19	570-2705	SPINNER CRESCENT PANEL
20	570-2711	HIDE THE NUMBERS PLAY PANE

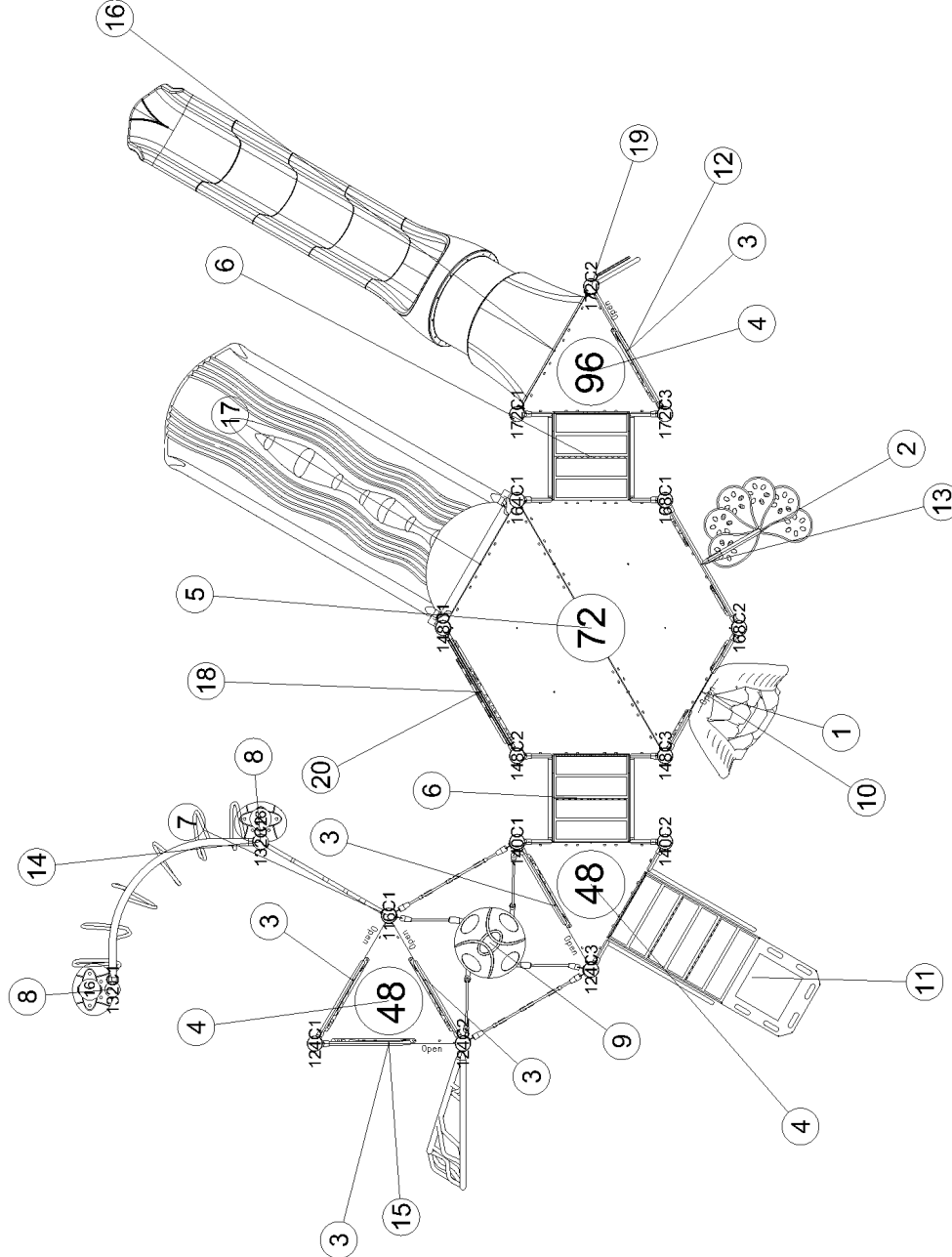

March 31, 2022

SERIES: Intensity, Nucleus
 COMPONENT PLAN
 DRAWN BY: John Uelmen

Holthus Playground
 3130 Holen Avenue
 York, NE 68467

Creative Sites, LLC
 905-152218-1

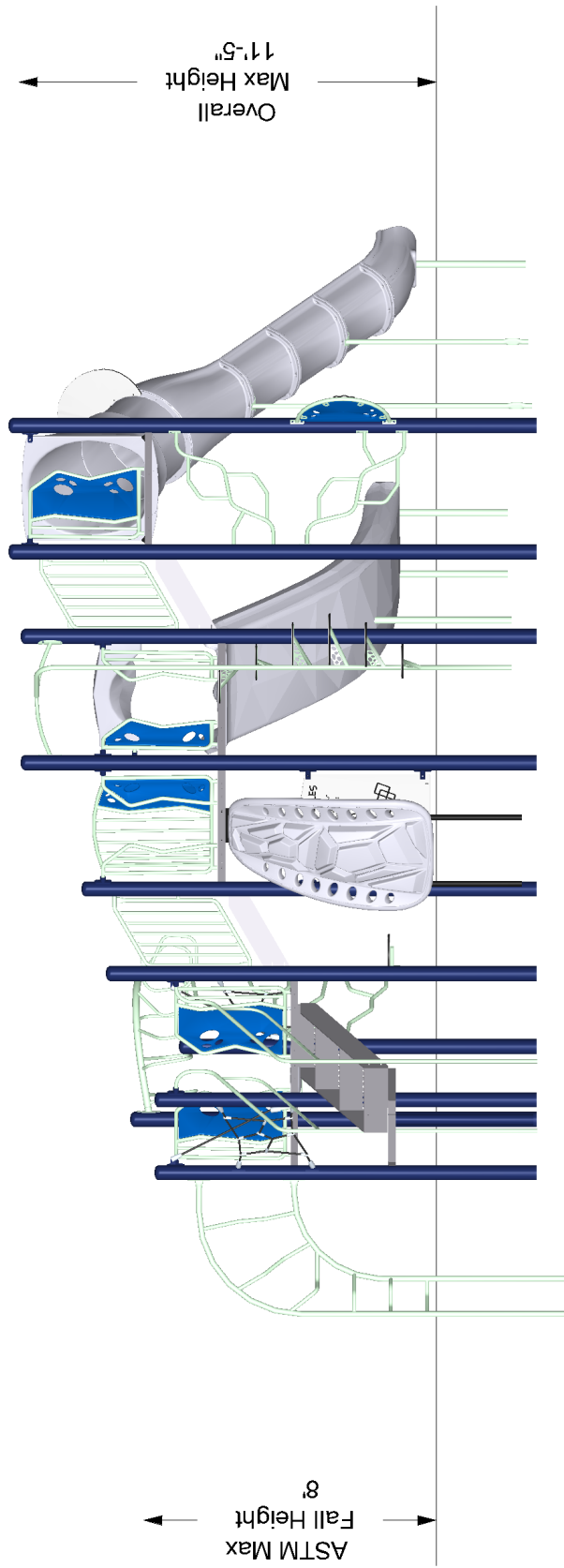

The protective surfacing for this design must accommodate the critical fall height.



March 31, 2022

SERIES: Intensity, Nucleus
 ELEVATION PLAN
 DRAWN BY: John Uelmen

Holthus Playground
 3130 Hohen Avenue
 York, NE 68467

Creative Sites, LLC
 905-152218-1

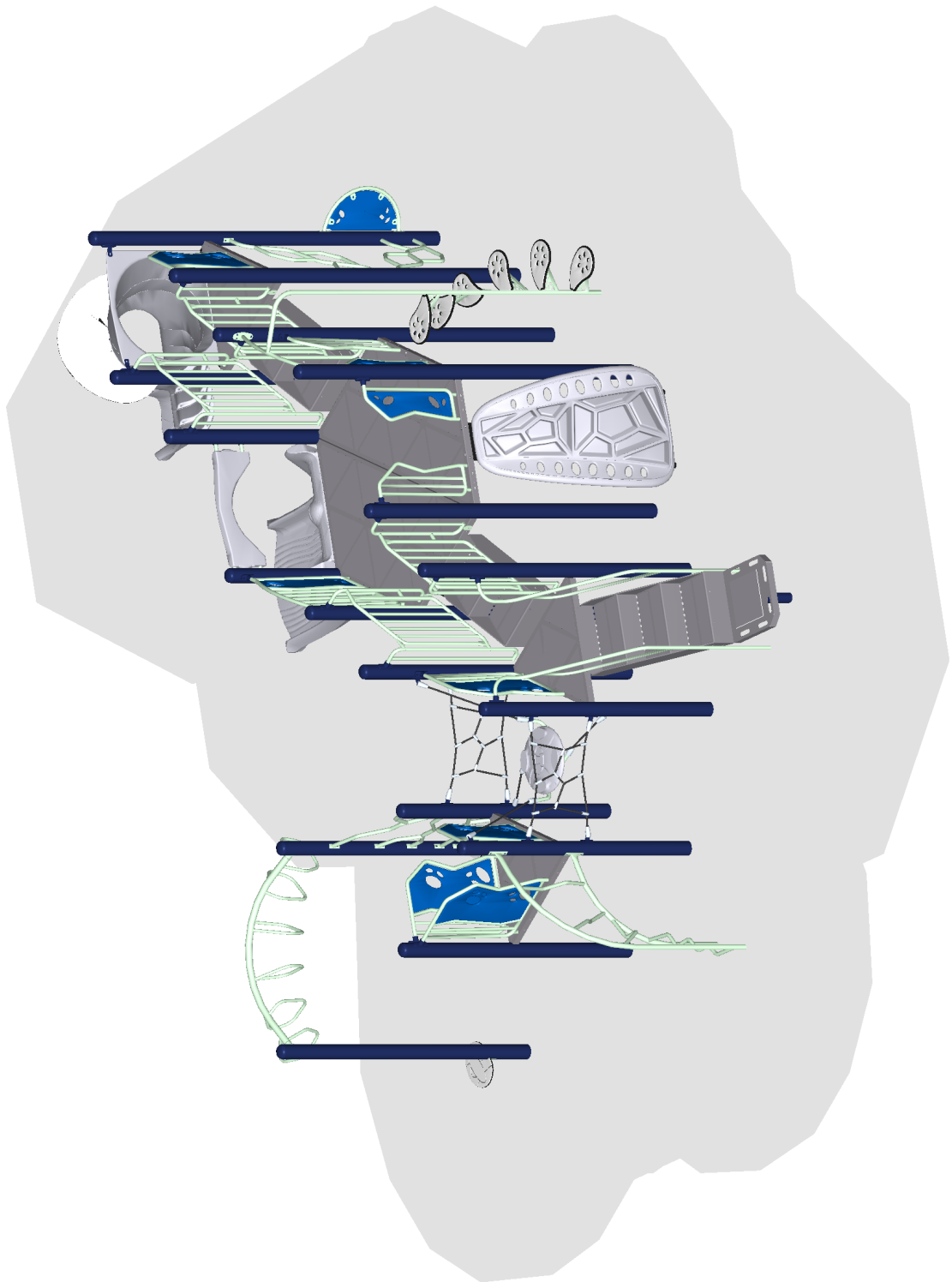

Burke

March 31, 2022

SERIES: Intensity, Nucleus
ISOMETRIC PLAN
DRAWN BY: John Uelmen

Holthus Playground
3130 Holen Avenue
York, NE 68467

Creative Sites, LLC
905-152218-1



Proposal # 905-152218-1

March 31, 2022
2022 Pricing

Proposal Prepared for:
Terri Carlson
Holthus Community Center
3130 Holen Avenue
York, NE 68467
Phone: 402-363-2675

Project Location:
Holthus Playground
3130 Holen Avenue
York, NE 68467

Proposal Prepared by:
Creative Sites, LLC
11506 Pierce St
Omaha, NE 68144
Phone: 402-614-4606
Fax: 402-558-1998
jkutilek@cox.net

Julie Kutilek
Phone: 402-614-4606
Fax: 402-558-1998
julie@creative.omhcoxmail.com

Component No.	Description	Qty	User Cap	Ext. User Cap	Weight	Ext. Weight
Intensity						
370-0868	TREE BRANCH CLIMBER-4	1	4	4	33	33
370-1608	OVISTEP LAUNCH PAD	2	1	2	10	20
370-1677	90 DEGREE OVERHEAD, NUCLEUS	1	6	6	44	44
Nucleus						
072-0500-116C	5" OD X 116" CAPPED POST	1	0	0	61	61
072-0500-124C	5" OD X 124" CAPPED POST	3	0	0	65	195
072-0500-132C	5" OD X 132" CAPPED POST	2	0	0	69	138
072-0500-140C	5" OD X 140" CAPPED POST	2	0	0	74	148
072-0500-148C	5" OD X 148" CAPPED POST	3	0	0	78	234
072-0500-164C	5" OD X 164" CAPPED POST	1	0	0	86	86
072-0500-168C	5" OD X 168" CAPPED POST	2	0	0	88	176
072-0500-172C	5" OD X 172" CAPPED POST	3	0	0	90	270
270-0120	EVOLUTION UNITARY ENCLOSURE	1	0	0	34	34
270-0121	EVOLUTION STANCHION	1	0	0	43	43
270-0122	EVOLUTION OFFSET ENCLOSURE	5	0	0	34	170
270-0129	TRIANGLE PLATFORM	3	2	6	48	144
270-0131	HEXAGONAL PLATFORM S5P	1	12	12	287	287
370-0467	24" TRANSITION STAIR W/BARRIE...	2	2	4	164	328
370-1622	TAKTIKS TRAIL TOWER	1	5	5	52	52
370-1648	MANITOU CLIMBER 72"	1	4	4	86	86
370-1659	TRANSFER STATION, HANDRAIL 48"	1	6	6	210	210
370-1666	SHASTA CLIMBER, 80"-96"	1	4	4	32	32
370-1673	PETAL STEP CLIMBER 64"-72"	1	4	4	66	66
370-1696	VIA CLIMBER 48"-56"	1	2	2	68	68
470-0781	COBRA FUSION STRAIGHT 96"	1	2	2	258	258
470-0803	CONTOUR SLIDE, 64"-72"	1	4	4	232	232
570-0100	EVOLUTION BARRIER	1	0	0	52	52
570-2705	SPINNER CRESCENT PANEL	1	1	1	17	17
570-2711	HIDE THE NUMBERS PLAY PANEL, ...	1	2	2	73	73
600-0104	NPPS SUPERVISION SAFETY KIT	1	0	0	3	3
660-0103	MAINTENANCE KIT, STRUCTURE	1	0	0	7	7
660-0104	INSTALLATION KIT, STRUCTURE	1	0	0	5	5

Total User Capacity: 68



Proposal # 905-152218-1

March 31, 2022

2022 Pricing

Information is relative to the Mar 31 2022 4:35AM database.

Special Notes:

Prices do not include freight, unloading, material storage, site excavation/preparation, removal of existing equipment, removal of excess soil from footing holes, site security, safety surfacing, installation, or sales tax (if applicable). Prices are based on standard colors per CURRENT YEAR BCI Burke Catalog. Custom colors, where available, would be an extra charge. **Pricing is valid for 30 days from the date of this proposal.**



Proposal # 905-152218-1

March 31, 2022
2022 Pricing

Selected Color List

<u>Color Group</u>	<u>Color</u>
<i>Phase 1</i>	
Accessory	Mint
Platform	Gray
Kore Konnect	Navy
2 Color Extruded/Flat (outer)	Gray
2 Color Extruded/Flat (inner)	Black
Post	Navy
Rotomolded	Granite
1 Color Extruded/Flat	Blue

BURKE GENERATIONS WARRANTY®

The Longest and Strongest warranty in the industry

BCI Burke Company, LLC ("Burke") warrants that all standard products are warranted to be free from defects in materials and workmanship, under normal use and service, for a period of one (1) year from the date of shipment.

We stand behind our products. In addition, the following products are warranted, under normal use and service from the date of shipment as follows:

- One Hundred (100) Year Limited Warranty on aluminum and steel upright posts (including Intensity®, Synergy™, Nucleus®, Voltage®, Little Buddies®, ELEVATE®, ACTIVATE®, INVIGORATE™) against structural failure due to corrosion, deterioration or workmanship.
- One Hundred (100) Year Limited Warranty on KoreConnect® clamps against structural failure due to corrosion, deterioration or workmanship.
- One Hundred (100) Year Limited Warranty on Hardware (nuts, bolts, washers)
- One Hundred (100) Year Limited Warranty on bolt-through fastening and clamp systems (Synergy™, Intensity®, Nucleus®, Voltage®, Little Buddies®, ELEVATE®).
- Twenty-Five (25) Year Limited Warranty on spring assemblies and aluminum cast animals.
- Fifteen (15) Year Limited Warranty on structure platforms and decks, metal roofs, table tops, bench tops, railings and barriers against structural failure due to materials or workmanship.
- Fifteen (15) Year Limited Warranty on all plastic components including StoneBorders against structural failure due to materials or workmanship.
- Ten (10) Year Limited Warranty on ShadePlay Canopies fabric, threads, and cables against degradation, cracking or material breakdown resulting from ultra-violet exposure, natural deterioration or manufacturing defects. This warranty is limited to the design loads as stated in the specifications.
- Ten (10) Year Limited Warranty on NaturePlay® Boulders and GRC products against structural failure due to natural deterioration or workmanship. Natural wear, which may occur with any concrete product with age, is excluded from this warranty.
- Ten (10) Year Limited Warranty on Full Color Custom Signage against manufacturing defects that cause delamination or degradation of the sign. Full Color Custom Signs also carry a two (2) year warranty against premature fading of the print and graphics on the signs.
- Five (5) Year Limited Warranty on Intensity® and RopeVenture® cables and LEVEL X® flex bridge against premature wear due to natural deterioration or manufacturing defects. Determination of premature wear will be at the manufacturer's discretion.
- Five (5) Year Limited Warranty on moving parts, including swing components, against structural failure due to materials or workmanship.
- Five (5) Year Limited Warranty on PlayEnsemble® cables and mallets against defects in materials and workmanship.
- Three (3) Year Limited Warranty on electronic panel speakers, sound chips and circuit boards against electronic failure caused by manufacturing defects.

The warranty stated above is valid only if the equipment is erected in conformity with the layout plan and/or installation instructions furnished by BCI Burke Company, LLC using approved parts; have been maintained and inspected in accordance with BCI Burke Company, LLC instructions. Burke's liability and your exclusive remedy hereunder will be limited to repair or replacement of those parts found in Burke's reasonable judgment to be defective. Any claim made within the above stated warranty periods must be made promptly after discovery of the defect. A part is covered only for the original warranty period of the applicable part. Replacement parts carry the applicable warranty from the date of shipment of the replacement from Burke. After the expiration of the warranty period, you must pay for all parts, transportation and service charges.

Burke reserves the right to accept or reject any claim in whole or in part. Burke will not accept the return of any product without its prior written approval. Burke will assume transportation charges for shipment of the returned product if it is returned in strict compliance with Burke's written instructions.

THE FOREGOING WARRANTIES ARE EXCLUSIVE AND IN LIEU OF ANY OTHER WARRANTY, EXPRESS OR IMPLIED, INCLUDING BUT NOT LIMITED TO ANY IMPLIED WARRANTY OR MERCHANTABILITY OR FITNESS FOR A PARTICULAR PURPOSE. IF THE FOREGOING DISCLAIMER OF ADDITIONAL WARRANTIES IS NOT GIVEN FULL FORCE AND EFFECT, ANY RESULTING ADDITIONAL WARRANTY SHALL BE LIMITED IN DURATION TO THE EXPRESS WARRANTIES AND BE OTHERWISE SUBJECT TO AND LIMITED BY THE TERMS OF BURKE'S PRODUCT WARRANTY. SOME STATES DO NOT ALLOW THE EXCLUSION OF CERTAIN IMPLIED WARRANTIES, SO THE ABOVE LIMITATION MAY NOT APPLY TO YOU.

Warranty Exclusions: The above stated warranties do not cover: "cosmetic" defects, such as scratches, dents, marring, or fading; damage due to incorrect installation, vandalism, misuse, accident, wear and tear from normal use, exposure to extreme weather, immersion in salt or chlorine water, unauthorized repair or modification, abnormal use, lack of maintenance, or other cause not within Burke's control; and

Limitation of Remedies: Burke is not liable for consequential or incidental damages, including but not limited to labor costs or lost profits resulting from the use of or inability to use the products or from the products being incorporated in or becoming a component of any other product. If, after a reasonable number of repeated efforts, Burke is unable to repair or replace a defective or nonconforming product, Burke shall have the option to accept return of the product, or part thereof, if such does not substantially impair its value, and return the purchase price as the buyer's entire and exclusive remedy. Without limiting the generality of the foregoing, Burke will not be responsible for labor costs involved in the removal of products or the installation of replacement products. Some states do not allow the exclusion of incidental damages, so the above exclusion may not apply to you.

The environment near a saltwater coast can be extremely corrosive. Some corrosion and/or deterioration is considered "normal wear" in this environment. Product installed within 500 yards of a saltwater shoreline will only be covered for half the period of the standard product warranty, up to a maximum of five years, for defects caused by corrosion. Products installed in direct contact with saltwater or that are subjected to salt spray are not covered by the standard warranty for any defects caused by corrosion.

Contact your local Burke Representative for warranty information regarding Burke Turf® and Burke Tile products.

Terms of Sale

Pricing: Prices published in this catalog are in USD, are approximate and do not include shipping & handling, surfacing, installation nor applicable taxes. All prices are subject to change without notice. Contact your Burke representative for current pricing. Payments are to be made in USD.

Weights: Weights are approximate and may vary with actual orders.

Installation: All equipment is shipped unassembled. For a list of factory-certified installers in your area, please contact your Burke representative.

Specifications: Product specifications in this catalog were correct at the time of publication. However, product improvements are ongoing at Burke, and we reserve the right to change or discontinue specifications without notice.

Loss or Damage in Transit: A signed bill of lading is our receipt from a carrier that our shipment to you was complete and in good condition upon arrival. Before you sign, please check the Bill of lading carefully when the shipment arrives to make sure nothing is missing and there are no damages. Once the shipment leaves our plant, we are no longer responsible for any damage, loss or shortage.

For more information regarding the warranty, call Customer Service at 920-921-9220 or 1-800-356-2070.

01/2022

BCIBURKE.COM

Burke

800.266.1250

QUOTATION



Creative Sites, LLC
11506 Pierce Street
Omaha, Ne 68144
402-614-4606

DATE: April 8, 2022

Customer: City of York: Sourcewell ID #84195
Holthus Community Center
Attn: Terri Carlson
3130 Holen Avenue
York, NE 68467

Project: Playground Improvements

BCI Burke Company Sourcewell ID# #010521-BUR:

Playstructure	\$ 47,158.00
Less Contract Discount	\$- 3,301.00
Less Courtesy Discount	\$-10,563.00
Freight	<u>\$ 3,650.00</u>

Total \$ 36,944.00

Installation: \$ 23,300.00

Open Market Items:

Ecoturf Surfacing:

1,085sf Turf Area w/ Pad for 8' Fall Height \$ 17,034.00

Project Total \$ 77,278.00

****Delivery is 8-10 weeks ARO.**

****This quotation is good for 30 days.**

****Terms are net 30.**

****Sales tax is not included.**

Julie Kutilek
Creative Sites, LLC

Accepted by